

Distribution Automation Handbook

Section 8.10 Protection of Capacitor Banks

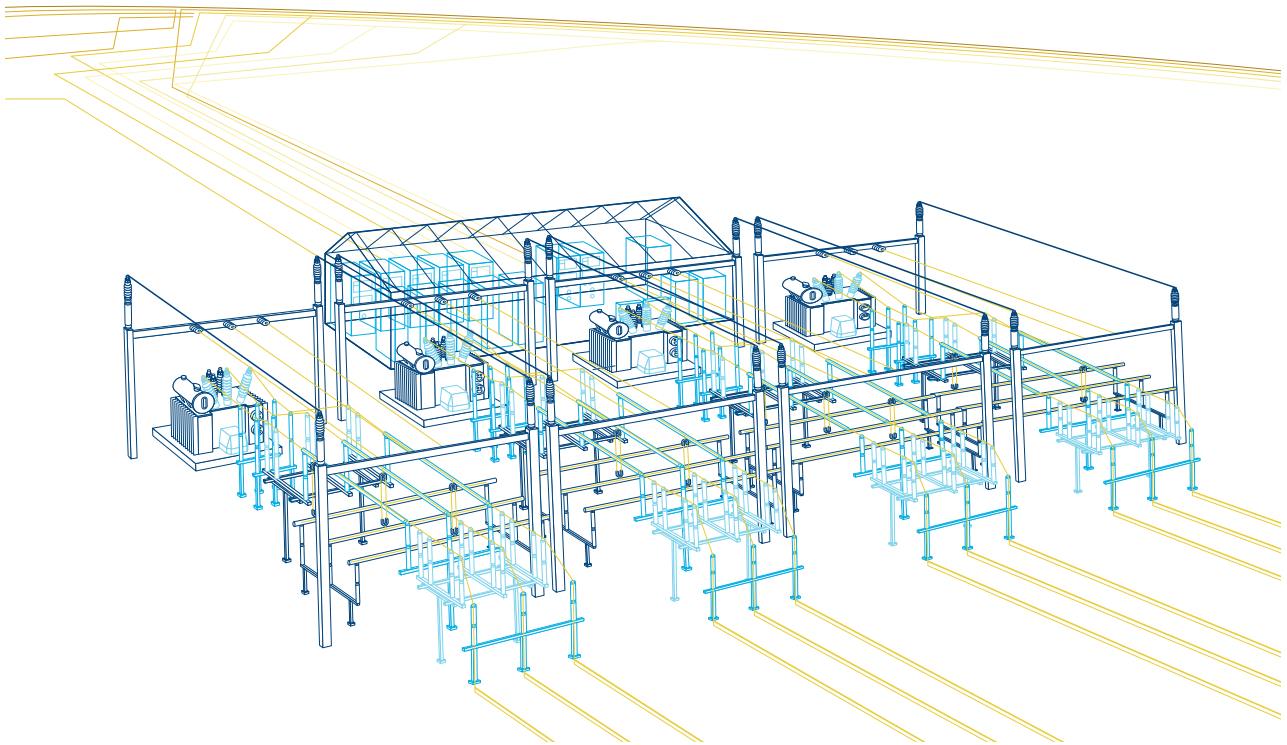

Contents

8.10	Protection of Shunt Capacitors Banks.....	3
8.10.1	<i>Introduction</i>	3
8.10.2	<i>Unbalance Protection</i>	3
8.10.2.1	EXTERNALLY FUSED BANKS	3
8.10.2.2	INTERNALLY FUSED BANKS	4
8.10.2.3	FUSELESS AND UNFUSED BANKS	5
8.10.2.4	BASIC UNBALANCE PROTECTION SCHEMES	6
8.10.2.4.1	Single-Wye Banks.....	6
8.10.2.4.2	Double-Wye Banks	8
8.10.2.4.3	Natural Unbalance Compensation	10
8.10.3	<i>Overload Protection</i>	11
8.10.4	<i>Short Circuit and Earth-Fault Protection</i>	14
8.10.5	<i>Negative-Sequence Overcurrent Protection</i>	15
8.10.6	<i>Undervoltage and Undercurrent Protection</i>	15
8.10.7	<i>Overvoltage Protection</i>	15
8.10.8	<i>Examples</i>	15

8.10 Protection of Shunt Capacitors Banks

Protection of shunt capacitor banks is described in references [8.10.1] to [8.10.5].

8.10.1 Introduction

Shunt capacitor banks (SCBs) are widely used in transmission and distribution networks to produce reactive power support. Located in relevant places such as in the vicinity of load centers the use of SCBs has beneficial effect on power system performance: increased power factor, reduced losses, improved system capacity and better voltage level at load points.

Shunt capacitor banks are protected against faults that are due to imposed external or internal conditions. Internal faults are caused by failures of capacitor elements composing the capacitor units, and units composing the capacitor bank. Also other faults inside the bank such as a flashover within the rack (short circuit over a single or multiple series groups of units of the same phase) and rack phase-to-phase and phase-to-earth faults belong to this category. Depending on the number of failed elements/units, the protection may first initiate an alarm to notify the operator about a potential bank problem. Tripping in due time must take place if the stress to the healthy capacitor elements/units or the measured phase currents and/or their sequence components exceed a predefined limit to minimize damage and to prevent possible rapid cascading of the fault by other failed elements/units. External power system conditions cause stress to SCBs such as bank overload due to the combined effect of sustained overvoltage and increased level of harmonics. On the other hand, the SCB may stress the power system if remained connected during abnormal system conditions possibly causing overvoltages that may damage both the SCB and other components of the system. The purpose of the protection is also to limit the effect of overload to a safe and acceptable level, and to prevent the abnormal system conditions from damaging the SCB by disconnecting it in case of loss-of-supply condition. Additionally, reconnection of the SCB must be prevented if not fully discharged. Also short circuits and earth faults between the circuit breaker and SCB terminals must be cleared by the SCB protection scheme in due time in order to minimize damage and stress to the system.

8.10.2 Unbalance Protection

Unbalance protection is provided against internal faults related to capacitor element/unit failures and against arcing faults within the bank. The type of the capacitor unit composing the bank and the bank configuration itself affects the sensitivity requirements set on the unbalance protection. In the following, different unit types are shortly reviewed and unbalance protection scheme alternatives are introduced for various bank configurations.

8.10.2.1 *Externally Fused Banks*

Figure 8.10.1 shows the basic structure of an externally fused capacitor unit and a wye-connected SCB. In this type, there are many element groups in series within the capacitor unit. Each series group consists of a few elements in parallel. An externally fused capacitor bank consists of many capacitor units in parallel within each series group [8.10.1].

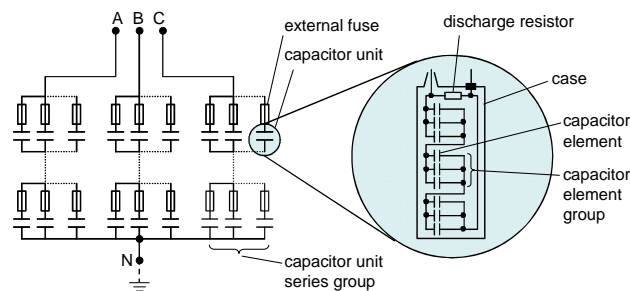

Figure 8.10.1: Externally fused capacitor unit (right) and wye-connected SBC (left)

In externally-fused SCBs, several capacitor element breakdowns may occur before the fuse removes the entire unit from service. The external fuse will operate when a capacitor unit becomes short-circuited, isolating the faulted unit. The unbalance protection should coordinate with the individual capacitor unit fuses so that the fuses operate to isolate the faulty capacitor unit before the protection trips the whole bank. The alarm level is selected according to the first blown fuse giving an early warning of a potential bank failure. The delayed trip level is based on the loss of additional capacitor units that cause a group overvoltage in excess of 110% of capacitor unit rated voltage or the capacitor unit manufacturer's recommendation [8.10.1]. In case of cascading failure or an arcing fault within the bank, the application of an additional high-set stage operating in minimum time is recommended to minimize damage.

8.10.2.2 Internally Fused Banks

Figure 8.10.2 shows the basic structure of an internally fused capacitor unit and a wye-connected SCB. Internally fused capacitor unit consists of a large number of individual capacitor elements that are disconnected when an element breakdown occurs.

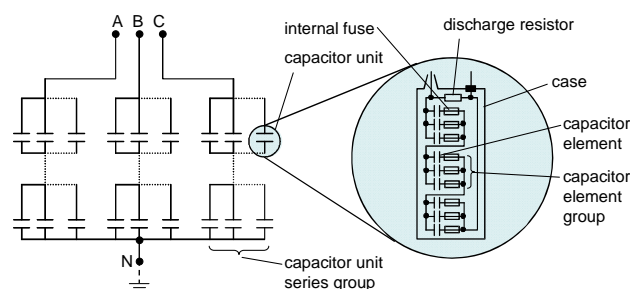

Figure 8.10.2: Internally fused capacitor unit (right) and wye connected SBC (left)

Internally-fused capacitor units are subject to overvoltage across elements within the unit as internal fuses blow and remove elements from a parallel group. The overvoltage on these remaining elements shall be considered in addition to the overvoltage on units without blown fuses. These considerations are to avoid the exposure of healthy capacitor units to voltages in excess of 110% of their rated voltage [8.10.1]. The alarm level is set above the natural unbalance, so that the protection would operate reliably on the loss of the first or second fuse. The delayed trip level can be set so that the number of operated fuses in the affected capacitor unit does not exceed the maximum number recommended by the manufacturer and that the voltage on the healthy capacitors does not exceed the overvoltage capability stated above. It should be noted that the element voltage in the unit with blown fuses may exceed 110% of the rated voltage. Opera-

tion speed in case of cascading failure or an arcing fault within the bank creating severe unbalance should be minimized by the application of an additional high-set stage.

8.10.2.3 Fuseless and Unfused Banks

The capacitor units in fuseless capacitor banks are similar to those used for externally fused banks. In the capacitor bank, individual capacitor units are connected in series with each other from the phase terminal to the neutral terminal. The capacitor unit of Figure 8.10.3 (right) illustrates a unit with three series groups containing three parallel connected elements each. In this construction, if one element fails, it short-circuits itself and the two elements in parallel with it.

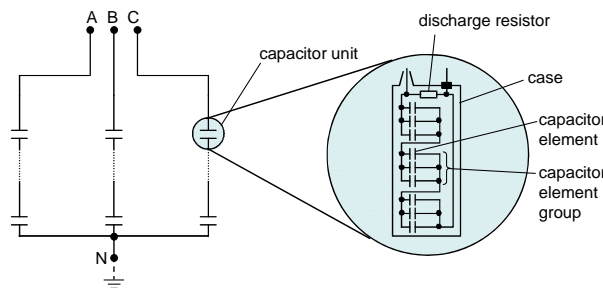

Figure 8.10.3: Fuseless capacitor unit (right) and wye-connected SBC (left)

Unbalance protection trips the bank when the resulting voltage becomes excessive on the remaining healthy capacitor elements or units. The delayed trip level can be set so that the voltage on the remaining elements in the affected series connection of elements and units does not exceed the maximum recommended by the standards or the manufacturer, which is typically 110% of the rated voltage [8.10.1]. The number of shorted elements for trip and alarm can be determined by calculating the voltage on the affected elements.

Unfused capacitor banks are similar to externally or internally fused banks (groups of capacitor units in parallel with each other and the groups connected in series from phase to neutral or earth) but there are no fuses either internally or externally, Figure 8.10.4. Capacitor units are imposed to overvoltage across elements within a unit as elements become shorted in case of failure. The overvoltage on the remaining elements shall be considered. Excessive voltage on the remaining elements may lead to cascading failure during system transient overvoltages [8.10.1].

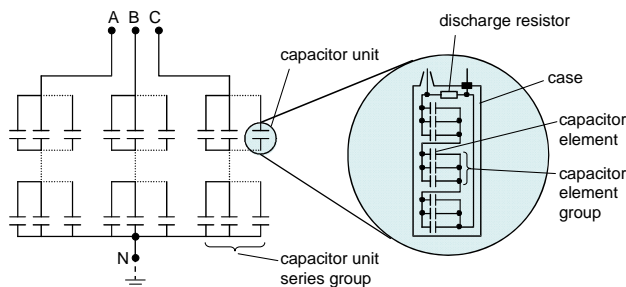

Figure 8.10.4: Unfused capacitor unit (right) and wye-connected SBC (left)

The alarm level is set above the natural unbalance so that the protection would operate reliably when shorting of the first element within a unit occurs. The delayed trip level can be set so that the voltage on the re-

maining elements in the affected capacitor unit does not exceed the maximum recommended by the manufacturer, and that the voltage on the healthy capacitors does not exceed the overvoltage capability of the units, which is typically 110% of the rated voltage [8.10.1]. As with the protection of the other capacitor unit and bank types, the operation speed in case of cascading failure or an arcing fault within the bank creating severe unbalance should be minimized by the application of an additional high-set stage.

8.10.2.4 Basic Unbalance Protection Schemes

Ideally, the neutral unbalance voltage or current equals zero for a healthy SCB. However, manufacturing tolerances of individual capacitor units and the natural unbalance of the power system causes neutral unbalance to be measured even in a healthy SCB. Capacitor unit and element failures cause this neutral unbalance to change. The unbalance protection of SCBs is based on the magnitude or the change of the neutral unbalance current or voltage, which for a given number of failed elements and units can be calculated based on the SCB configuration and its design parameters. This is widely described, for example in [8.10.1]. Here the most common unbalance protection scheme alternatives are reviewed.

8.10.2.4.1 Single-Wye Banks

The simplest method to detect unbalance in single unearthed wye banks is to measure the bank neutral or zero-sequence voltage. If the capacitor bank is balanced and the system natural unbalance equals zero, the neutral voltage will ideally be zero as well. A change in any phase of the bank will result in a change in the neutral or zero-sequence voltage. Figure 8.10.5 (top) shows a method that measures the voltage between capacitor neutral and earth using a VT and an overvoltage protection function. The voltage measurement can also be done by a resistive divider. This scheme is simple but the disadvantage is that the system unbalance and the natural unbalance of the bank are present in the measurement. An equivalent zero-sequence voltage that eliminates the system unbalance but not the natural unbalance can be obtained by utilizing three VTs with their high-side voltage wye-connected from phase-to-neutral, and the secondaries connected in broken delta. The VTs can either be connected at a tap in the capacitor bank, or VTs of the bank bus can be used instead. An alternative solution would be to use the numerically calculated zero-sequence voltage from phase-to-neutral voltages. Figure 8.10.5 (mid) shows this solution. Figure 8.10.5 (bottom) shows a scheme that removes the system unbalance and can be made to compensate for the natural capacitor unbalance. Its operation is based on the measurement of the differential zero-sequence voltage. The terminal side zero-sequence voltage is derived from three phase-to-earth VTs with their high side wye-connected and their secondaries connected in broken delta. Numerically calculated zero-sequence voltage from phase-to-earth voltages measured by VTs or resistive voltage dividers can also be used. The differential voltage between the terminal side and the bank neutral voltage measurement due to system unbalance will be compensated inherently for all conditions of system unbalance because the system unbalance appears as similar neutral voltage at both the bank terminals and the bank neutral. The remaining differential voltage is due to bank natural unbalance, that is, manufacturing tolerances. This can then be compensated by means of a natural unbalance compensation function, which is typically a standard feature in the related functionality of modern IEDs.

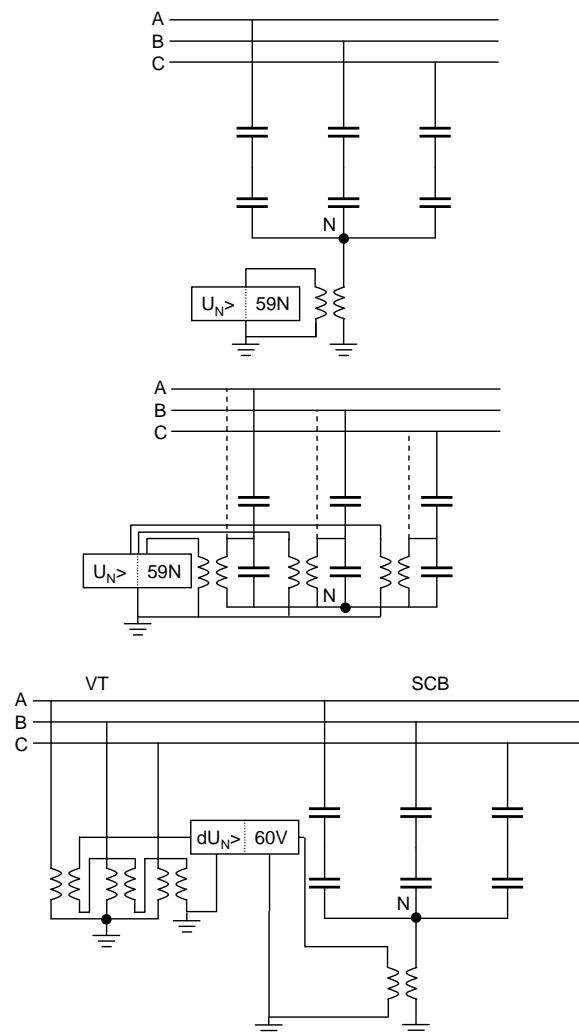

Figure 8.10.5: Unbalance protection schemes for unearthed single-wye-connected SCBs

Figure 8.10.6 (top) shows a scheme used with earthed single-wye SCBs based on a current transformer installed on the connection between the capacitor bank neutral and earth. Unbalance in the bank causes a current to flow between the neutral and earth. This scheme is simple but the disadvantage is that again the system unbalance and the natural unbalance of the bank create an unbalance current to flow. Additionally, system faults with earth connection cause the corresponding earth fault current component to flow in the bank neutral requiring coordination between the bank protection and system earth fault protection. The scheme can be implemented with a sensitive overcurrent protection function, or an overvoltage protection function together with a small shunt resistor can be applied instead. Similarly, as in case of unearthed SCBs, voltage differential principle can be used alternatively with the same advantages as above. Figure 8.10.6 (bottom) shows the implementation principle. This scheme uses two voltage transformers per phase: one connected to a tap on the capacitor bank and the other at the bank bus. In case of double wye banks, the second VT is connected at a similar tap on the leg of the other wye.

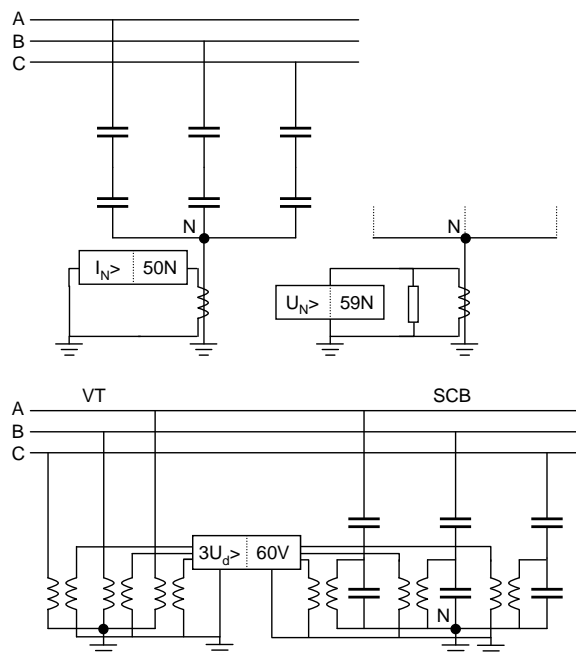

Figure 8.10.6: Unbalance protection schemes for earthed single-wye-connected SCBs

8.10.2.4.2 Double-Wye Banks

Typically, a double-wye-type of bank allows a secure unbalance protection with a simple uncompensated function, because any system zero-sequence component affects both wyes equally, but a failed capacitor unit will appear as an unbalance between the neutrals. This is also an advantage in case of earthed SCBs because coordination with the system earth-fault protection is not required which allows fast operation of the unbalance protection.

The scheme of Figure 8.10.7 (top) uses a current transformer on the connection of the two neutrals and a simple overcurrent protection function. Figure 8.10.7 (bottom) uses a voltage transformer connected between the two neutrals and an overvoltage protection function. The effect of system voltage unbalance is avoided in both schemes, but the effect of natural unbalance of the bank is not, which causes circulating current or voltage between the neutral points in the healthy state. Therefore, if a very sensitive protection is required, the scheme must be completed with natural unbalance compensation function.

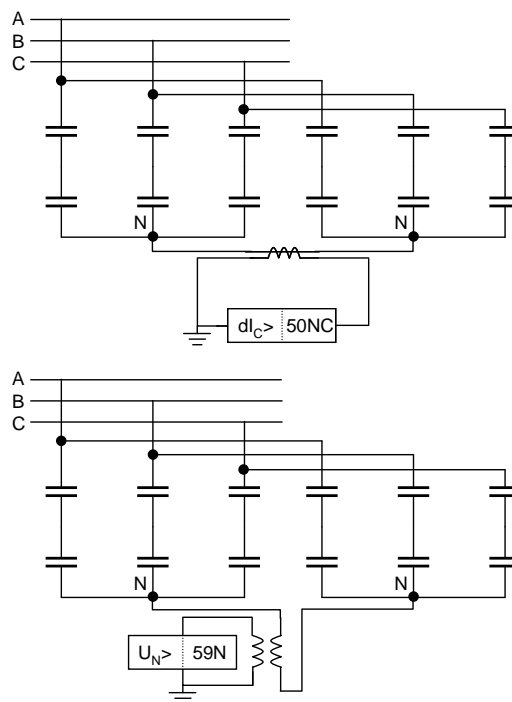

Figure 8.10.7: Unbalance protection schemes for unearthed double-wye-connected SCBs

Figure 8.10.8 shows a scheme for an earthed double-wye SCB, where a current transformer is installed on each neutral of the two sections of a double-wye. The neutrals are connected together and earthed from one point. The current transformer secondaries are cross-differentially connected to an overcurrent protection function, so that the scheme is insensitive to any outside system condition that affects both sections of the capacitor bank in the same way, for example, in case of an outside earth fault—equal zero-sequence current flows in the neutrals of both sections, but ideally the function measures zero current due to the CT connection. Alternatively, the connections from neutral to earth from the two wyes may be in opposite directions through a ring core current transformer, Figure 8.10.8 (bottom).

Larger SCBs use an H-configuration in each phase with a current transformer connected between the two legs, Figure 8.10.9. The unbalance protection is based on the measurement of the current between the legs. As long as all the capacitors are healthy, no current will flow through the current transformers. If a capacitor element or unit fails, some current will flow through the current transformer. The advantage of this scheme is that it is insensitive to system unbalance, but the effect of the natural unbalance of the bank causes circulating current to flow between the legs. In addition, in case of an earthed H-configuration, any system zero-sequence component affects similarly all legs and therefore ideally no current will flow through the leg CTs in this case. If the natural unbalance compensation function is in use, the H-configuration allows a very sensitive and fast unbalance protection, and this is why it is mostly used on large banks with many capacitor units in parallel.

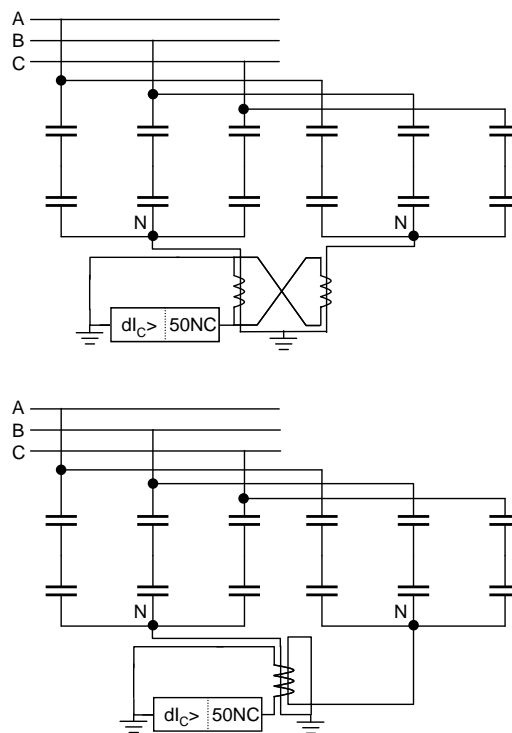

Figure 8.10.8: Unbalance protection schemes for earthed double-wye-connected SCBs

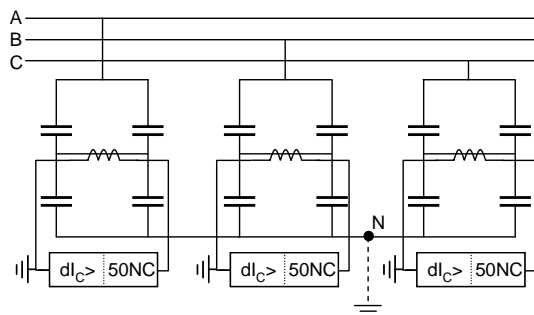

Figure 8.10.9: Unbalance protection schemes for earthed and unearthed H-connected SCBs

8.10.2.4.3 Natural Unbalance Compensation

In practice, the unbalance current or voltage measured by the unbalance protection in case of a healthy SCB does not equal zero. Also loss of individual capacitor units or elements will result to somewhat different magnitudes of unbalance current or voltage as theoretically calculated based on the SCB design [8.10.1]. The reason for this is the primary and secondary unbalance, which exists more or less on all SCB installations. The primary unbalance is due to system voltage unbalance and capacitor manufacturing tolerance. Secondary unbalance errors are due to possible measurement inaccuracies of the measuring transformers and due to changes in capacitance resulting from temperature variation in the bank. The total natural unbalance error will be a vectorial sum of the primary and secondary unbalance. The error may be in a direction to make the protection more insensitive or to cause a false operation. According to general recommendations [8.10.1], if the natural unbalance error approaches 50% of the required alarm setting, compensation

should be provided in order to correctly alarm for the failure of one unit or element as specified. Figure 8.10.10 shows one implementation principle of the natural unbalance compensation [8.10.6]. The phase current \underline{I}_A is used as a synchronizing input for the compensation function, which means that the natural unbalance currents can be compensated for both amplitude and phase angle. The natural unbalance phasor(s) are recorded during commissioning of the SCB by the IED including the unbalance protection function and then used for compensating the natural unbalance currents to zero level. The natural unbalance current phasor $d\underline{I}_{C_natural}$ during the healthy state in relation to phase A current is recorded first, Figure 8.10.10, left. After this, the natural unbalance current phasor is subtracted from the measured unbalance current phasor $d\underline{I}_{C_measured}$ to obtain the actual unbalance current phasor $d\underline{I}_{C_compensated}$ resulting only from faulted units or elements, Figure 8.10.10, right. During healthy state, the current phasor $d\underline{I}_{C_compensated}$ then equals zero.

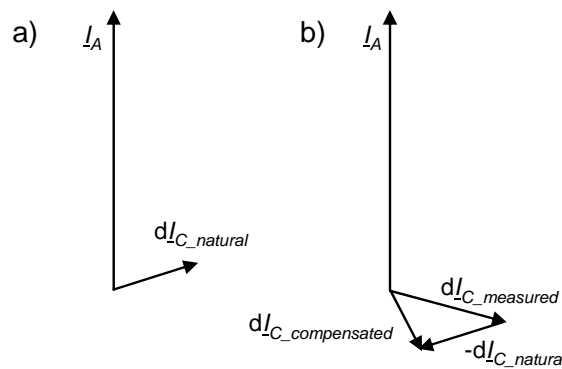

Figure 8.10.10: Principle of natural unbalance compensation in current-based unbalance protection [8.10.6]

8.10.3 Overload Protection

The SCB may be subjected to overvoltage resulting from combined fundamental and harmonic content. This overvoltage increases the load current drawn by the SCB and stresses the layers of film that compose the individual capacitor elements. This kind of capacitor element is sensitive to a peak voltage across it, so the peak voltage measurement principle is preferred when implementing the protection. If the stress exceeds the SCB capability, the bank should be removed from service in due time, [8.10.1] to [8.10.5]. The protection can be based on direct voltage measurement, but a current-based overload protection with suitable current input filtering can be used as well. This is an advantage, since the overall dedicated SCB protection scheme can be implemented basically without voltage measurement, which simplifies the scheme and makes the scheme more economical. Current-based protection is based on the fact that the voltage across the SCB can be expressed in terms of current as per Equation (8.10.1).

$$\frac{|U_{Cnf}|}{U_N} = \frac{|I_{Cnf}|}{n \cdot I_N} \quad [p.u.] \tag{8.10.1}$$

where

U_{Cnf} is the n^{th} harmonic component of the SCB voltage,

I_{Cnf} is the n^{th} harmonic component of the SCB current,

U_N is the rated SCB voltage and

I_N is the rated SCB current

Therefore, by filtering the measured phase current in accordance with Equation (8.10.1), the protection can be made to correspond to the actual voltage across the SCB, taking into consideration the possible harmonics. The principle of this type of protection and the applied filtering characteristic is represented in Figure 8.10.11. Further, the current measurement after the filtering is based on the so-called peak-to-peak measurement principle as illustrated in Figure 8.10.12. In this example, the true RMS-value measurement of the filtered current shows 1.00 per unit, whereas the peak value measurement scaled to RMS-value by dividing it by $\sqrt{2}$ shows 1.03 per unit. Obviously, the latter one must be utilized in the overload protection. The operation time is selected in accordance with the SCB withstand capability and the applied standards or manufacturers recommendations [8.10.1], [8.10.2], [8.10.3], [8.10.4], [8.10.5] and [8.10.7]. Therefore, the operation time characteristic of the overload protection function needs to closely match the overload limit of the SCB. Figure 8.10.13 shows an example of this [8.10.7]. The protection provides two stages: time-delayed alarming and time-delayed tripping. The purpose of the alarming stage is to notify about a potential bank problem in due time, taking into account the response time of the network voltage control. The start current settings in the example are selected as 1.05 and 1.1 times the rated current of the SCB.

According to reference [8.47], the overload protection can also be implemented by measuring directly the RMS-value of the SCB-current. Reference [8.47] states that the capacitor units shall be suitable for continuous operation at an RMS-current of 1.30 times the current that occurs at rated sinusoidal voltage and rated frequency, excluding transients. This implies that the protection must start at latest when the RMS-value of the measured current including the combined effect of harmonics exceeds 1.3 times the rated SCB-current. In the RMS-based method, the setting is given in RMS-current, whereas in the method applying the special filter the setting represents the actual voltage over the SCB. Therefore, the latter method gives a more accurate picture of the loading state of the SCB than the RMS-based method.

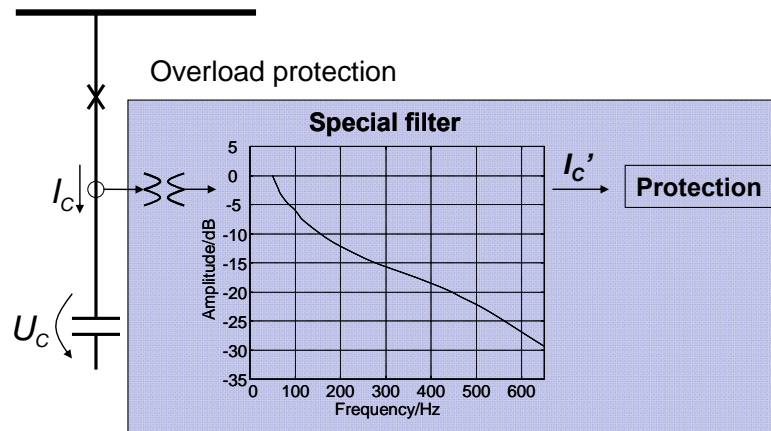

Figure 8.10.11: Principle of current-based SCB-overload protection using special filtering. I_C' is the filtered SCB-current that is proportional to the actual SCB-voltage.

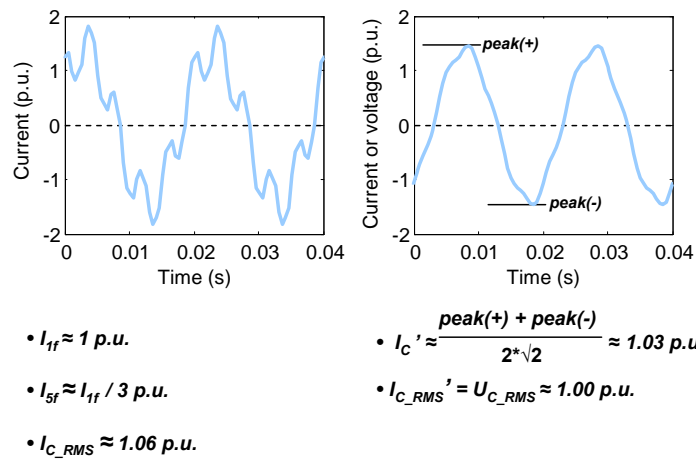

Figure 8.10.12: Measurement principle of the current-based SCB-overload protection. All values are expressed as per unit of the rated SCB-current or voltage. Left: unfiltered SCB-current. Right: filtered SCB-current or unfiltered voltage.

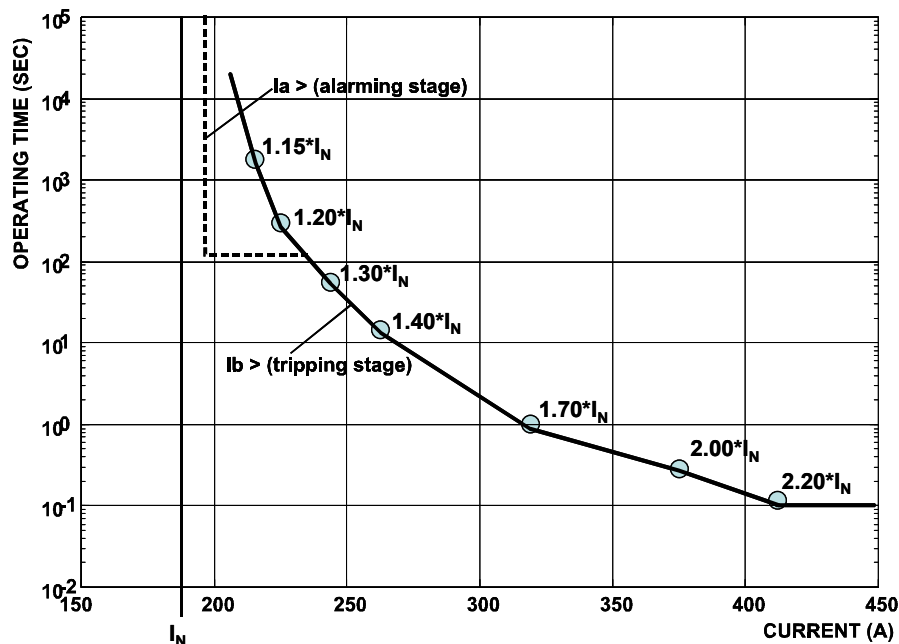

Figure 8.10.13: Example operating time characteristic of the SCB-overload protection. The dots indicate the overload limits as per [8.10.1] and [8.10.2]. I_N denotes the rated SCB-current.

8.10.4 Short Circuit and Earth-Fault Protection

Protection against flashovers between phases and flashovers to neutral and to earth must be provided. To fulfill this requirement, a two-stage overcurrent and earth-fault protection is typically applied. The high-set stages are used to provide protection against faults between the SCB terminals and the circuit breaker. The time-delayed low-set stages are used to detect faults within the bank for which greater sensitivity is required. According to the reference [8.10.1], time-delayed overcurrent stages can be applied with normal settings without encountering false operations due to inrush currents. The desirable minimum starting level is 135% of nominal phase current for the earthed wye banks or 125% for unearthed banks. High-set stages, if applied, should be set high enough to override inrush or outrush transient currents. Successful operation of modern IEDs may be obtained by setting the high-set overcurrent stages at three to four times the capacitor rated current to override back-to-back bank switching [8.10.1]. For non-effectively earthed systems with unearthed SCBs, the low-set stage of the non-directional or directional earth-fault protection should be set to as sensitive as possible to detect faults within the SCB. An earth-fault within the bank manifests itself also in the unbalance current of the bank. In this sense, the unbalance protection provides backup protection for the earth-fault protection. In effectively earthed systems with earthed wye SCBs, the unbalanced bank load current caused by an external earth fault may be sufficient to cause the protection to start and trip the bank if the non-directional low-set stage is set too low. To prevent a possible false tripping, the current setting is typically selected above the capacitor phase current [8.10.1].

8.10.5 Negative-Sequence Overcurrent Protection

If the phases of the bank are constructed in distinct separate structures, a flashover within the capacitor bank will begin as a short circuit fault over of a single-series group. Such a fault produces very little phase overcurrent. For this type of fault, fast protection is provided by the unbalance protection. However, depending on the applied scheme and the fault type, the unbalance current may be out of the normal reliable operating range of the unbalance protection. For example, if a flashover occurs across the entire limb, the current in the neutral connection can be very high. Also for certain capacitor bank configurations, some faults within the bank will not cause an unbalance signal and will remain undetected, for example rack-to-rack faults for banks with two-series groups connected phase-over-phase and using neutral voltage or current for unbalance protection, and rack-to-rack faults for certain H-bridge connections [8.10.1]. Therefore, if the unbalance protection fails to operate, the initial fault may spread until it becomes severe enough to operate the short circuit protection resulting to considerable damage. For these reasons, a backup protection for the unbalance protection is recommended. The negative-sequence overcurrent protection can be used for this purpose to complement the scheme securing the tripping in the above cases [8.10.1].

8.10.6 Undervoltage and Undercurrent Protection

Once disconnected from the system, the SCB cannot be reconnected immediately due to the trapped charge within the capacitor units. Otherwise, catastrophic damage to the circuit breaker may occur [8.10.1]. To discharge the bank, each individual capacitor unit has a resistor to discharge the trapped charge within 5 minutes. Undervoltage or undercurrent protection function with a time delay is used to detect the bank going out of service and prevent closing the breaker until the set time has elapsed. This delay prevents tripping of the bank for system faults external to the bank. The undervoltage or undercurrent function should be set so that it will not operate for voltages that require the capacitor bank to remain in service.

8.10.7 Overvoltage Protection

The SCB may be subjected to overvoltages resulting from abnormal system operating conditions. If the system voltage exceeds its normal limit, the bank becomes overloaded and other system equipments become stressed. To limit the effects of overvoltage to a safe level, the bank should be removed from service in due time. The tripping of the bank lowers the voltage in the vicinity of the bank, reducing also the overvoltage on other system equipment. Therefore, this function operates also as a system protection. Definite time or inverse time-delayed three-phase overvoltage protection measuring the bus voltage is typically used. Overvoltage protection needs to be coordinated with the dedicated current-based overload protection providing also a backup protection functionality.

8.10.8 Examples

Figure 8.10.14 shows the proposed protection functions for a small unearthed single-wye-connected bank (top) and for a large earthed H-connected bank (bottom). The latter scheme may be completed with a backup protection functionality if required (not shown in the figure). The functions have been implemented in a multifunctional IED and are listed as follows:

- Short circuit and overcurrent protection (50, 51)
- Unbalance protection (59N, 51NC)

- Overload protection, current-based (51C)
- Negative-sequence overcurrent (51Q)
- Undercurrent protection to detect loss-of-supply condition (37)
- Earth-fault protection (51N, 50N)
- Undervoltage, overvoltage and residual overvoltage protection for supervising the supplying network (59, 27, 59N)

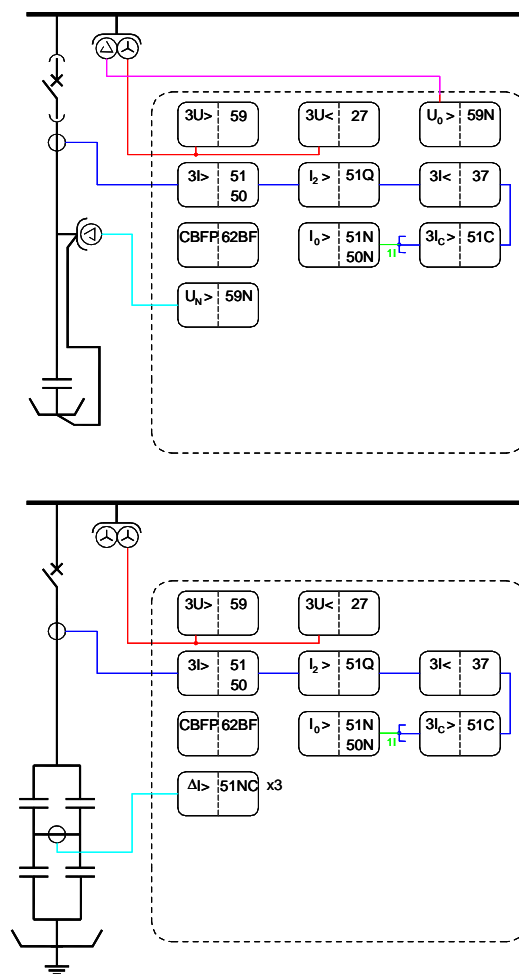

Figure 8.10.14: Protection schemes for SCBs. Top: small unearthed single-wye-connected bank. Bottom: large earthed H-connected bank.

References

- [8.10.1] "American National Standard for Protection of Shunt Capacitor Banks," ANSI/IEEE Publication Std C37.99-2000.
- [8.10.2] "Shunt capacitors for AC power systems having a rated voltage above 1 000 V - Part 1: General," IEC 60871-1, Geneva, July 2005.
- [8.10.3] "Shunt capacitors for AC power systems having a rated voltage above 1 000 V - Part 2: Endurance testing," IEC/TS 60871-2, Geneva, June 1999.
- [8.10.4] "Shunt capacitors for AC power systems having a rated voltage above 1 000 V - Part 3: Protection of shunt capacitors and shunt capacitor banks," IEC/TS 60871-3, Geneva, March 1996.
- [8.10.5] "Shunt capacitors for AC power systems having a rated voltage above 1 000 V - Part 4: Internal fuses," IEC 60871-4, Geneva, August 1996.
- [8.10.6] "CUB3Cap, 3-Phase Current Unbalance Protection for H-bridge Connected Shunt Capacitor Banks," Function block manual, ABB Oy, Distribution Automation, 2005.
- [8.10.7] "OL3Cap, 3-Phase Overload Protection for Shunt Capacitor Banks," Function block manual, ABB Oy, Distribution Automation, 2005.

Document revision history

Document revision/date	History
A / 05 March 2011	First revision

Disclaimer and Copyrights

The information in this document is subject to change without notice and should not be construed as a commitment by ABB Oy. ABB Oy assumes no responsibility for any errors that may appear in this document.

In no event shall ABB Oy be liable for direct, indirect, special, incidental or consequential damages of any nature or kind arising from the use of this document, nor shall ABB Oy be liable for incidental or consequential damages arising from use of any software or hardware described in this document.

This document and parts thereof must not be reproduced or copied without written permission from ABB Oy, and the contents thereof must not be imparted to a third party nor used for any unauthorized purpose.

The software or hardware described in this document is furnished under a license and may be used, copied or disclosed only in accordance with the terms of such license.

Copyright © 2011 ABB Oy

All rights reserved.

Trademarks

ABB is a registered trademark of ABB Group. All other brand or product names mentioned in this document may be trademarks or registered trademarks of their respective holders.

This page is intentionally left blank.

Contact information

ABB Oy, Distribution Automation

P.O.Box 699

Visiting address: Muottitie 2A

FI-65101 Vaasa, FINLAND

Phone: +358 10 22 11

Fax: +358 10 22 41094

www.abb.com/substationautomation

