

Cisco Catalyst 9120

Access Point Deployment Guide



This document is intended for trained and experienced technical personnel familiar with the existing Cisco Wireless Networking Group (WNG) product line and features.

Catalyst 9120 overview:

Designed for next-generation mobility

The Cisco Catalyst® 9120 access points with high-performance Wi-Fi 6 capabilities and innovations in RF performance, security, and analytics enable end-to-end digitization and help accelerate the rollout of business services by delivering beyond Wi-Fi.

- **Resilient:** Increased efficiency and cellular-like determinism with up to 4x capacity relative to 802.11ac access points, even in demanding environments
- **Secure:** Along with built-in security, and Software Defined Access SDA support, these access points can deliver standards-compliant, enhanced security on open Wi-Fi
- **Intelligent:** With multi-RF support paramount for Internet of Things (IoT) devices and expanded ecosystem partnerships, the Catalyst 9100 portfolio provides unprecedented visibility from mobile devices on the Cisco network along with enhanced Cisco DNA assurance

The Catalyst 9100 Series access points come with built-in security in the form of secure boot, runtime defenses, image signing, integrity verification, and hardware authenticity. The Catalyst 9100 portfolio, with Wi-Fi 6, provides reliable wireless to meet the needs of your branch and campus network deployments.

Catalyst 9120 key features:

- Next-generation 802.11ax access points with 4x4 MIMO with four spatial streams:
 - 4x4:4 on 5 GHz with MU-MIMO and downlink/uplink OFDMA
 - 4x4:4 on 2.4 GHz with MU-MIMO and downlink/uplink OFDMA
 - Combined data rate of 5.2 Gbps
- Cisco DNA ready
- Cisco RF ASIC w/Next-Generation CleanAir® and upgradable RF Features
- Built-in Bluetooth Low Energy (BLE) radio (Bluetooth 5.0)
- Multigigabit Ethernet (1 Gbps, 2.5 Gbps)
- USB
- Supports up to 400 Wi-Fi devices (200 per radio)
- IoT ready (Zigbee, Thread)
- Internal and external antenna options
- Operating temperature 0° to 50°C (32° to 122°F)

Catalyst 9120 key capabilities:

- Orthogonal Frequency Division Multiple Access (OFDMA) and MU-MIMO - Deliver a more predictable performance for advanced applications and IoT
- Superior security with RF signature capture, rogue detection, and device classification
- Container support – Multilingual Access Point with dockers' support to host IoT applications
- Multigigabit Support - Seamlessly offload network traffic without any bottlenecks and allow for higher throughputs with minimum cost
- Integrated Bluetooth 5.0 – Multi-RF technologies to enable IoT use cases
- Internal and external antenna support – Flexible deployment options for various campus types
- Multiple input power options, ranging from 802.3af (limited) to 802.3bt

In addition, the Cisco Catalyst 9100 Series access points support software-defined access—Cisco's leading enterprise architecture.

Choosing the right access point



Cisco Catalyst 9120i and Cisco Catalyst 9120e (external antenna version)

Use cases for 9120i

- Aesthetics (carpeted areas)
- No additional antenna costs
- Less items to install
- Sometimes better for high ceilings

Use cases for 9120e

- Industrial applications requiring a higher temperature
- External or directional antennas are desired (inside/outside use)
- Longer range or need to focus energy
- Dual 5-GHz (covering different cell areas) directional/omnidirectional
- Use of legacy single-band antennas or different 2.4-GHz/5-GHz cells

Catalyst 9120 new mechanical design:

The Catalyst 9100 Series access points are built from the ground up, with a new aerodynamic look and smooth finish, integrating RF excellence and next-generation technologies to provide the best-in-class wireless experience without compromise. While packing several high-performance features, the hardware is redesigned to deliver higher efficiencies in a more compact form factor to make visually appealing Wi-Fi deployments commonplace.

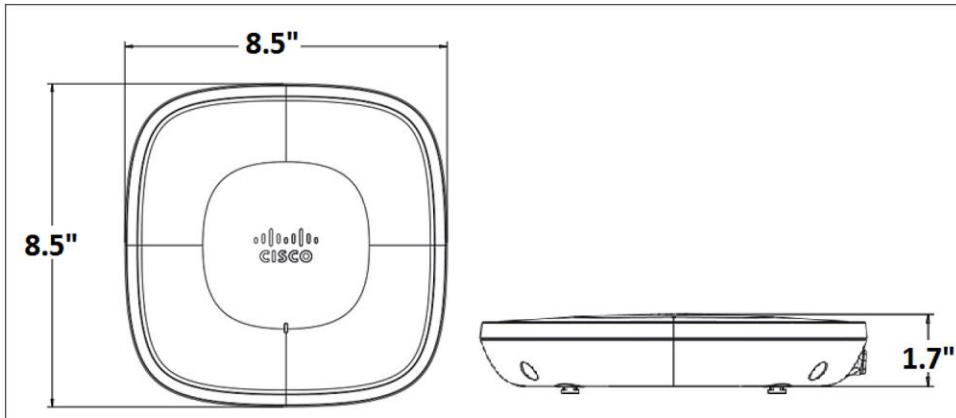

SKU	Physical Dimensions	Weight
Catalyst 9120I	8.5" x 8.5" x 1.7"	2.87 lb. (1.3 kg)

Mechanicals: Catalyst 9120I

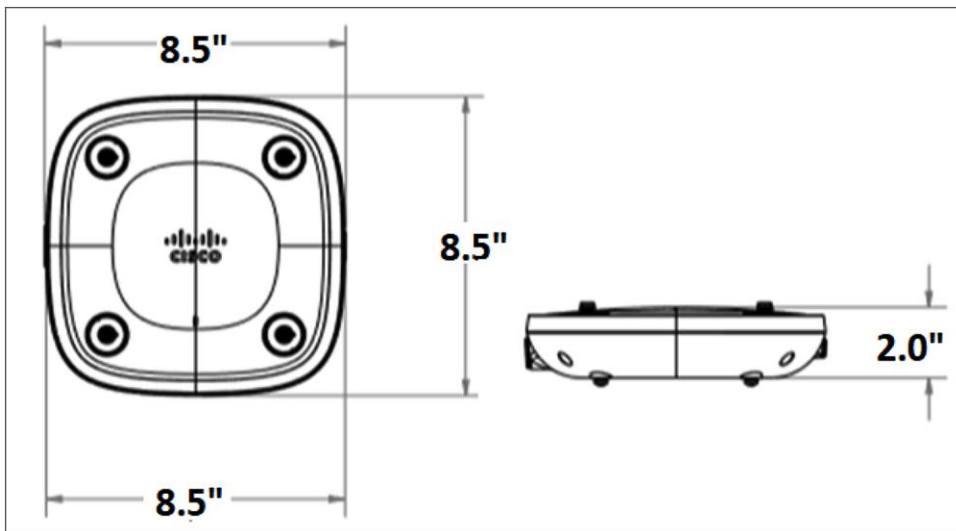

SKU	Physical Dimensions	Weight
Catalyst 9120E	8.5" x 8.5" x 2"	3.0 lb. (1.36 kg)

Mechanicals: Catalyst 9120E

Note: The 9120 Series is approximately 13% lighter and has 25% lower volume than the AP-2800 Series, yet is easy to deploy using the same Cisco Aironet™ AIR-BRACKET-1 and AIR-BRACKET-2 mounting hardware.

Catalyst 9120 mounting options

There are many different installation options available depending upon the requirements of the customer. Brackets are available from Cisco as well as third-party companies. During the ordering process, the customer may choose one of two brackets (but not both). Each bracket is a zero-dollar (\$0) option at the time of configuration. If the customer does not choose a bracket, the selection default is AIR-AP-BRACKET-1, which is the most popular for ceiling installations. The other choice is a universal bracket that carries part number AIR-AP-BRACKET-2.

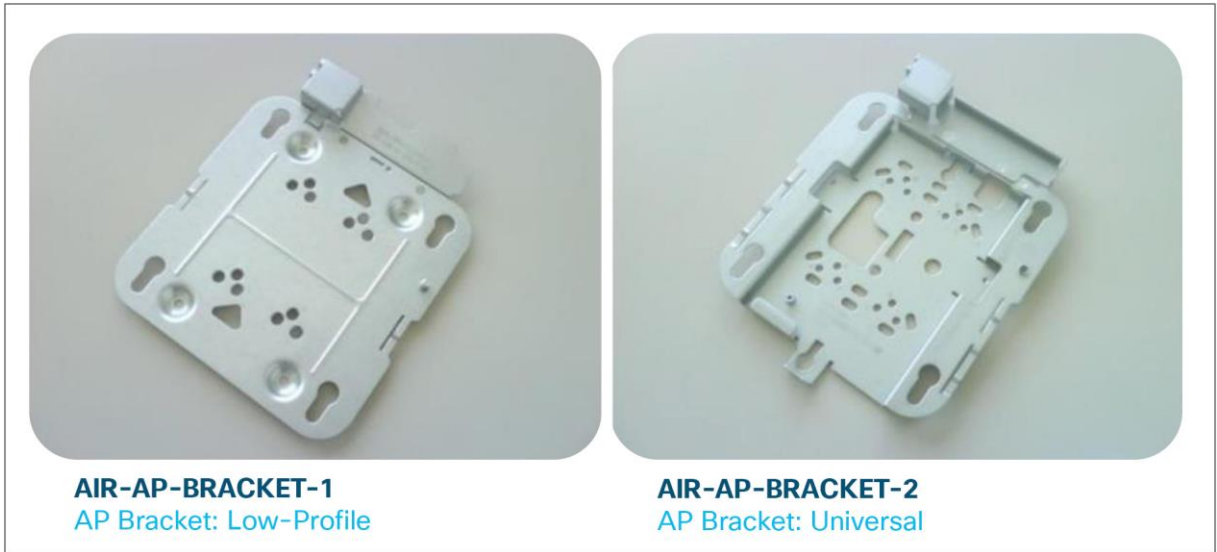

Two different types of mounting brackets

If the AP will be mounted directly to a ceiling on the gridwork, then AIR-AP-BRACKET-1 mounts flush and has the lowest profile. However, if the AP will be mounted to an electrical box or other wiring fixture, or inside a National Electrical Manufacturers Association (NEMA) enclosure or perhaps wall mounted, then AIR-AP-BRACKET-2 is a better choice. The extra space in the bracket allows for wiring, and the extra holes line up with many popular electrical boxes. When mounting the bracket to the ceiling gridwork, some ceiling tiles are recessed. For this reason, two different styles of ceiling clips, recessed and flush rails, are available see below.



Different clips are available for attaching to ceiling grid work

Channel rail adapters - Cisco part number AIR-CHNL-ADAPTER

When mounting APs to ceiling channel rails such as the ones shown in Figure 10, an optional channel adapter is used: AIR-CHNL-ADAPTER. It comes in a two-pack and attaches to the ceiling grid clip above. Refer to Figures 11 and 12.

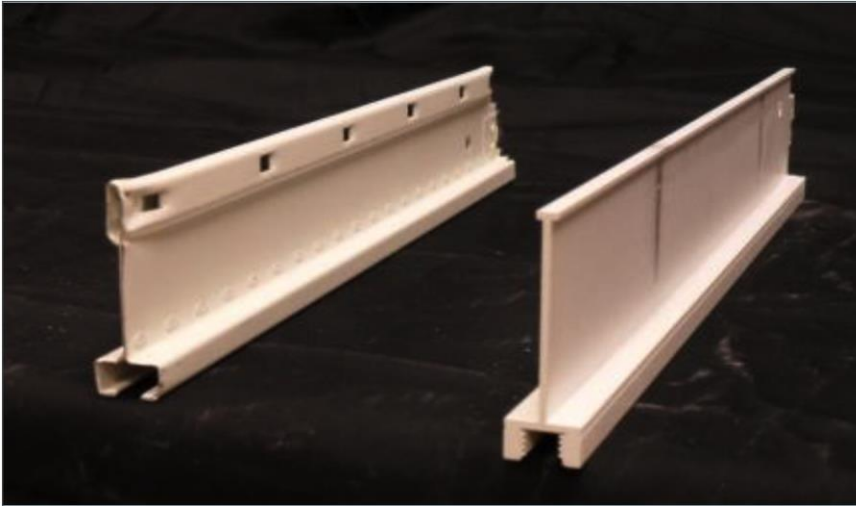

Example of channel rails



AIR-CHNL-ADAPTER (left) slides onto the rails

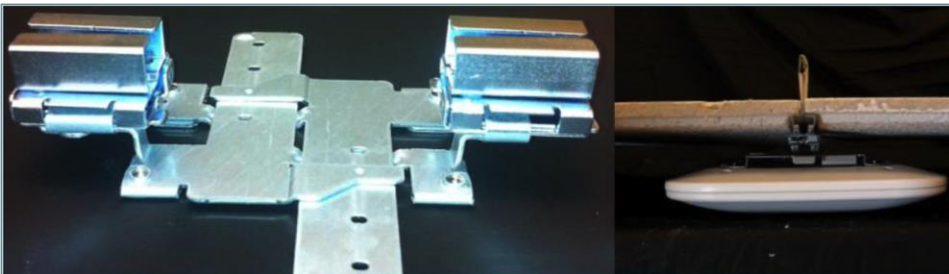

AIR-CHNL-ADAPTER mounted to rail clip (left) and finished installation (right)

Wall mounting the AP

When wall mounting is desired, the installer should understand that walls can be a physical obstacle to the wireless signal; therefore, maintaining 360-degree coverage may be compromised by the wall. If the wall is an outside wall and/or the goal is to send the signal in a 180-degree pattern instead, a directional antenna often referred to as a “patch” antenna may be a better choice assuming the external antenna model is used.

Avoid wall mounting APs with internal antennas unless you use an optional right-angle mount (available from third-party companies), as the internal antenna model was designed to mount to a ceiling to provide 360-degree coverage.



AccelTex mounting solutions for 9115, 9117, and 9120 Series access points

The following third-party companies are recommended for different types of mounting solutions.

www.oberoninc.com/

www.acceltex.com/

www.ventev.com/

If wall mounted in a non-ceiling orientation the signal may penetrate the floor above and below, causing unintended coverage that could result in additional, needless roaming access when a mobility client (for example, a user with a Wi-Fi phone walks by on an adjacent floor).

Wall mounting access point with internal antennas



Coverage is always **more uniform** when installed on the ceiling tile or grid area

Wall mounting is acceptable for small deployments such as hotspots, kiosks, transportation or small coverage areas. **But NOT for enterprise deployments.**



Note: Wall mounting may create unwanted coverage areas on the floor above or below

This is not desirable for voice as it may cause excessive roams and is directional as metal is behind the antennas (backside).

Caveats when wall mounting the 9120 Series

Changing the color of an AP

If there is a desire to change the color of an AP, rather than painting the AP, which would void the warranty, consider using colored vinyl tape or using a colored plastic cover from Oberon.



If the environment requires an AP color change or you have a requirement to remove the Cisco logo or LED you have options

www.oberonwireless.com

Phone (814) 867-2312

Part numbers:
1140/3500i/3600i-SKIN
3600e-SKIN
1260/3500e-SKIN

Specifications:

- Fabricated from textured ABS plastic
- The skin is virtually transparent to access point radio frequency signals
- Attaches to access point with Velcro tabs (included)
- Standard color is black
- Skins are paintable
- Custom colors are available on request. Please contact your Oberon representative

Oberon third-party option for changing the AP color, adding a custom logo, or hiding the LED



Another third-party option is a vinyl “skin” such as this one from AccelTex

Above the ceiling tiles

The Catalyst 9120i and 9120e are rated for installation in the Plenum area (UL-2043). Many customers prefer to locate the AP so that nothing can be visible on the ceiling. In some cases, this is preferred for aesthetic reasons, so customers may install the AP above a drop ceiling. This also may be preferred in high-theft areas such as classrooms or in areas where policy dictates that nothing can be visible on the ceiling.

When this is a hard requirement, optional T-bar hangar accessories from third-party companies such as Erico and Cooper can be used (Figure 18). The Erico Caddy 512a, the Cooper B-Line BA50a, or similar T-bar Grid can be used.

For more information, see:

www.erico.com/

www.cooperindustries.com/

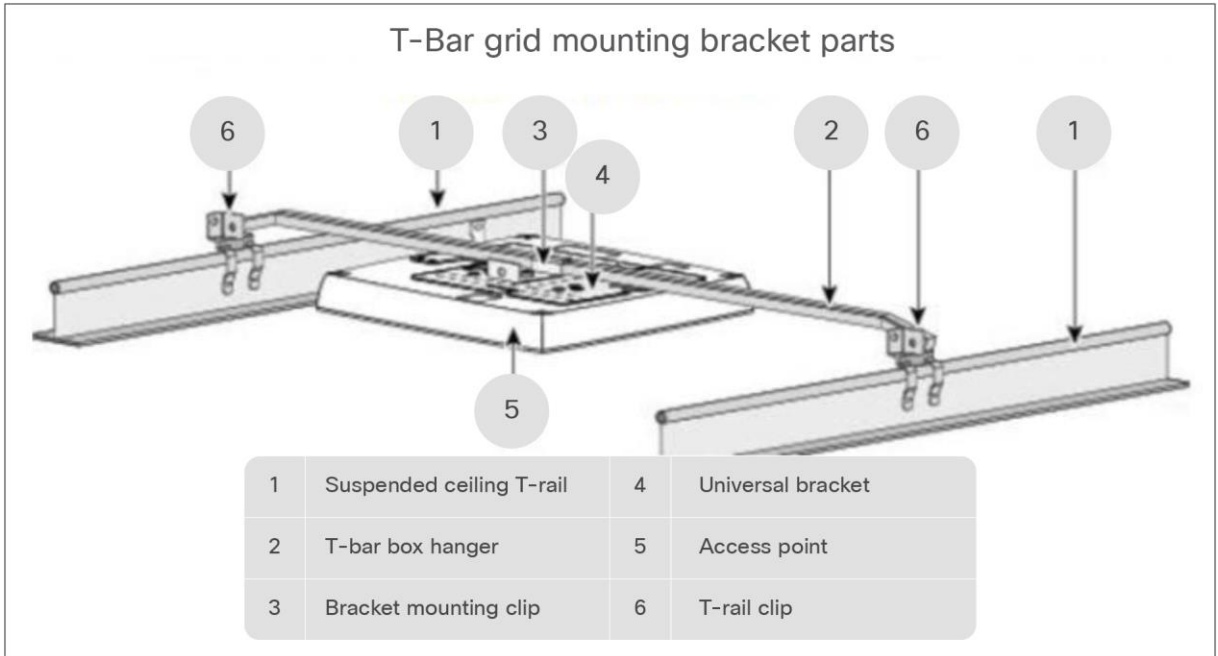

Example of how to hang an AP above the ceiling tiles

NOTE: Installing APs above the ceiling tiles should only be done **when mounting below the ceiling is not an option**. The tiles must not be conductive; such installations can certainly degrade advanced RF features such as voice and location, so verify coverage and performance. Always try to mount the AP as close to the inside middle of the tile as possible, and avoid areas with obstructions.



Installing the AP above ceiling tiles: pick an area clear of obstructions, avoid ceiling clutter

Areas with high vibration

If the access point is installed using a “side arm”–type mount or other mounting locations where there is a likelihood of high vibration, it is recommended that a padlock or metal pin be used to prevent the AP from vibrating loose from the bracket.

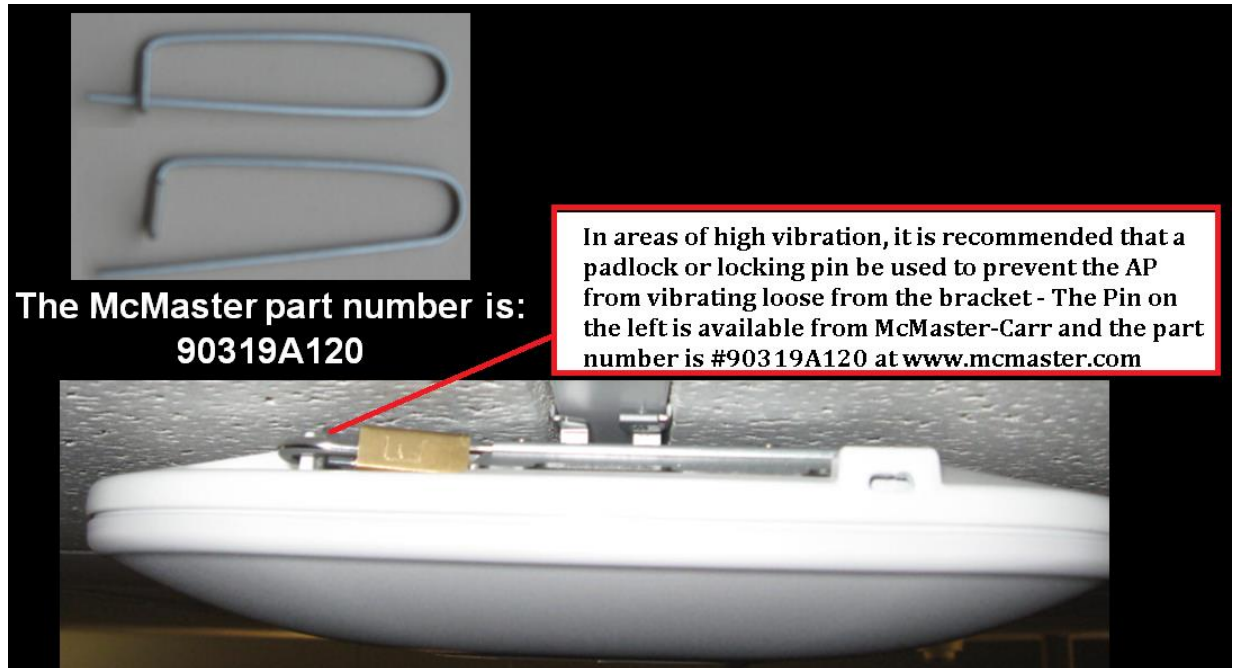

A metal pin or padlock will not deteriorate over time so it is better than a plastic tie

Catalyst 9120 and Power over Ethernet (PoE)

Benefit – Flexible power options even with limited 802.3af power

Catalyst 9120 series	Power Source	Power Type	2.4 GHz Radio	5 GHz Radio	Link Speed	USB	PD Power Draw
C9120AXI	802.3at	POE	4x4	4x4	2.5G	Y	25.5 W
C9120AXE / C9120AXP	802.3at	POE	4x4	4x4	2.5G	Y	25.5 W
C9120AXI / C9120AXE / C9120AXP	802.3af	POE	1x1	1x1	1G	N	13.4 W
C9120AXI / C9120AXE / C9120AXP	802.3af	POE	2x2	N	1G	N	13.4 W
C9120AXI / C9120AXE / C9120AXP	802.3af	POE	N	2x2	1G	N	13.4 W

PoE draw: 9120 Series

Note: Ethernet cable recommendation is CAT-6 with a maximum distance of 328 feet (100 meters). Power required at the Power Source Equipment (PSE) will be higher depending on the cable length and other environmental issues.

Expanded Multigigabit Offerings for Access

Catalyst 9400



C9400-LC-48UX



4-slot to 10-slot chassis

Catalyst 9300



C9300-48UN
C9300-48UXM
C9300-24UX



C9300-NM-4M

Catalyst compact



2x Multigigabit PoE+

Cisco has a line of multigigabit products that can easily power these access points

Catalyst 9120 – Integrated Cisco RF ASIC

Benefit – Improving RF spectrum and performance of the access point client-serving radios.

Next-generation Wi-Fi 6 access points starting with the Catalyst 9120 Series now contain a new radio based on a custom-designed Cisco silicon referred to as an ASIC (application-specific integrated circuit). This analytics radio enhances the performance of the access point's client serving radios, as all this deep RF analysis is done on the RF ASIC.

The function of the Cisco RF ASIC (actually two ASIC chips) one is to analyze a frequency or range of frequencies of interest converting the received RF signal into Quadrature Signals known as I/Q data. This I/Q data is then passed onto a second ASIC that is a dedicated baseband processor for a deep RF analysis such as determining granular changes in the phase and amplitude as well as the modulation characteristics of the inspected signal.

The I/Q data is evaluated by the Spectrum Analysis Engine (SAGe), which is custom designed to identify sources of non-Wi-Fi interference, at the highest resolution, in the most simple and effective way.

Think of the RF ASIC as a unique piece of hardware that not only contains CleanAir and SAGe, but is also much more advanced and has the capability to support advanced features in the future with software upgrades.

The initial capabilities of the RF ASIC include all the features of CleanAir/SAGe as well as the ability to sense DFS (Dynamic Frequency Selection) events to augment the serving radio's analysis of DFS for the very best DFS detection in the industry. This greatly improves spectrum analysis and provides an always-on "second opinion" of the radio spectrum. This is referred to as dual DFS. In addition, the RF ASIC also plays a key role in Cisco's RRM (Radio Resource Management) by providing off-channel analysis.



Catalyst 9120i with the Cisco RF ASIC chip

Catalyst 9120i antenna system

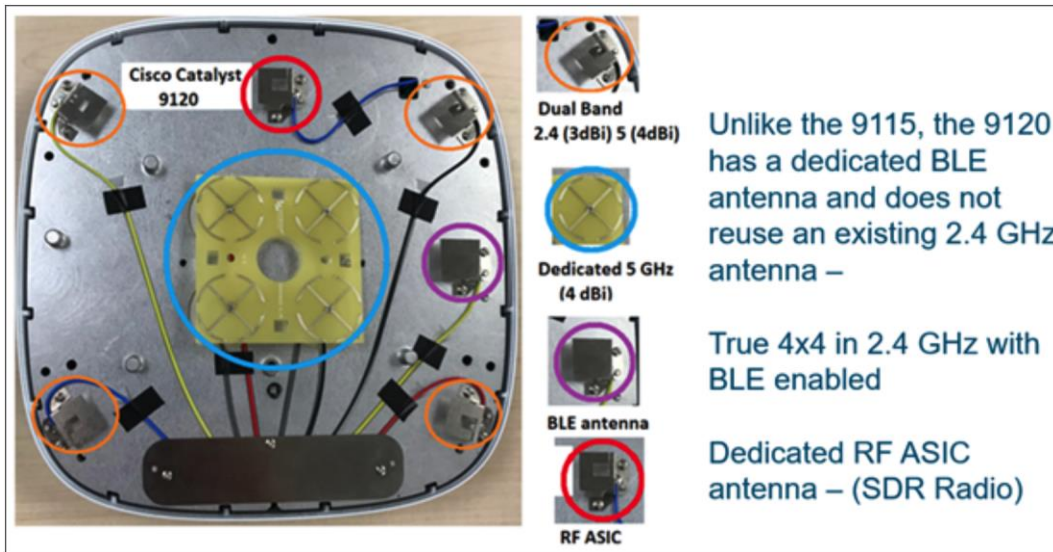

9120i internal antenna system

The 9120i has one of the most advanced antenna systems available on an access point.

The main serving radios default in this configuration:

- Dedicated 5-GHz radio tied to the dual-band client serving antennas @ 4 dBi
- (eXclusive OR) known as XOR radio is (defaulted to 2.4 GHz) tied to the dual-band client serving antennas @ 3 dBi
- Dual 5-GHz mode – XOR 2.4 GHz disabled secondary 5-GHz radio tied to dedicated 5-GHz antennas @ 4 dBi

In addition to the serving radio antennas, there are two other antennas:

- BLE antenna with a gain of 2.1 dBi
- RF ASIC antenna with a gain @ 2.4 GHz of 3 dBi and @ 5 GHz of 4 dBi

The RF ASIC antenna is connected to a dedicated software-defined radio for spectrum analysis and other advanced RF features. The RF ASIC antenna is of the same design as the serving radio antennas to provide a similar view of the network as the serving radios.

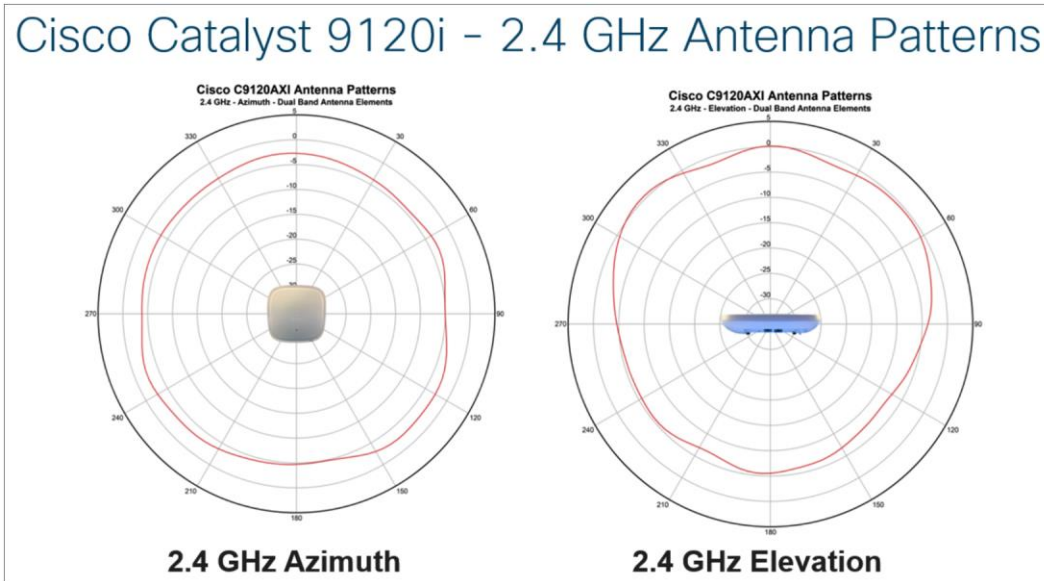

9120i 2.4-GHz antenna patterns

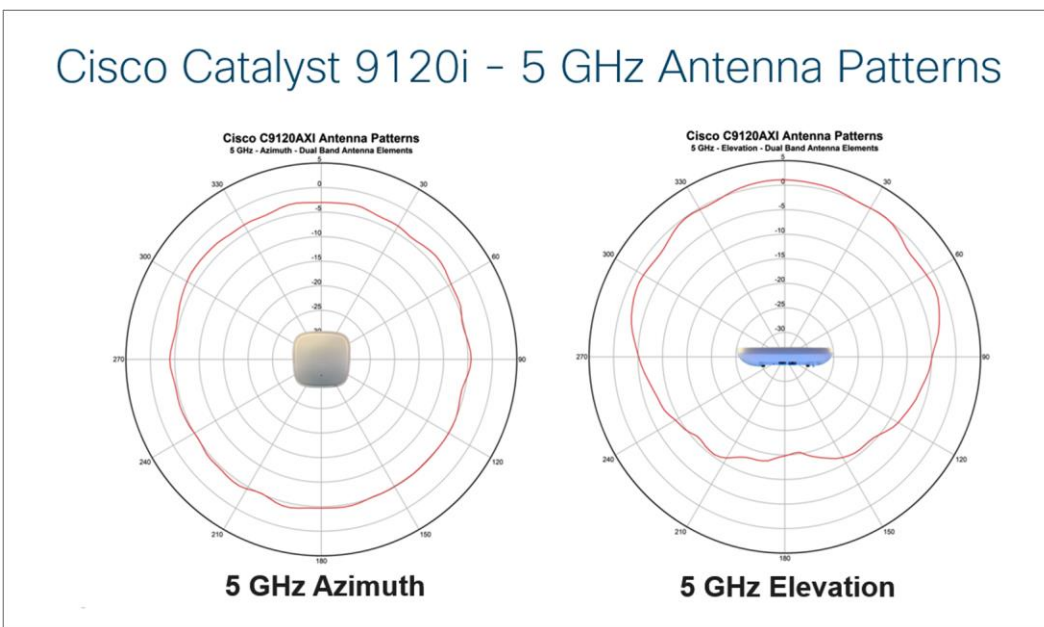

9120i 5-GHz antenna patterns

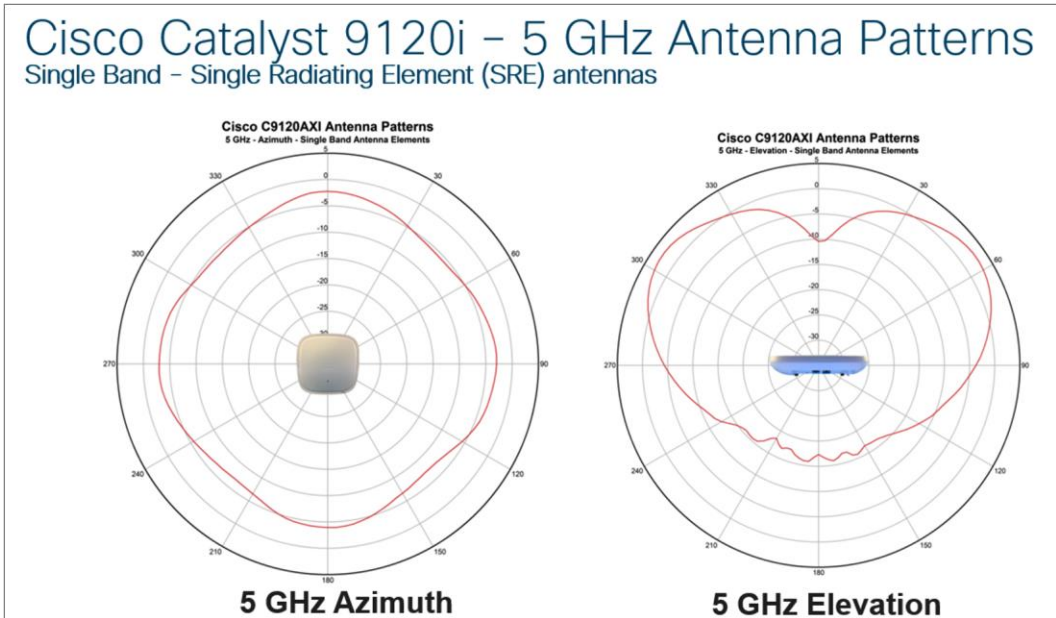

9120i secondary 5-GHz single-band antenna patterns

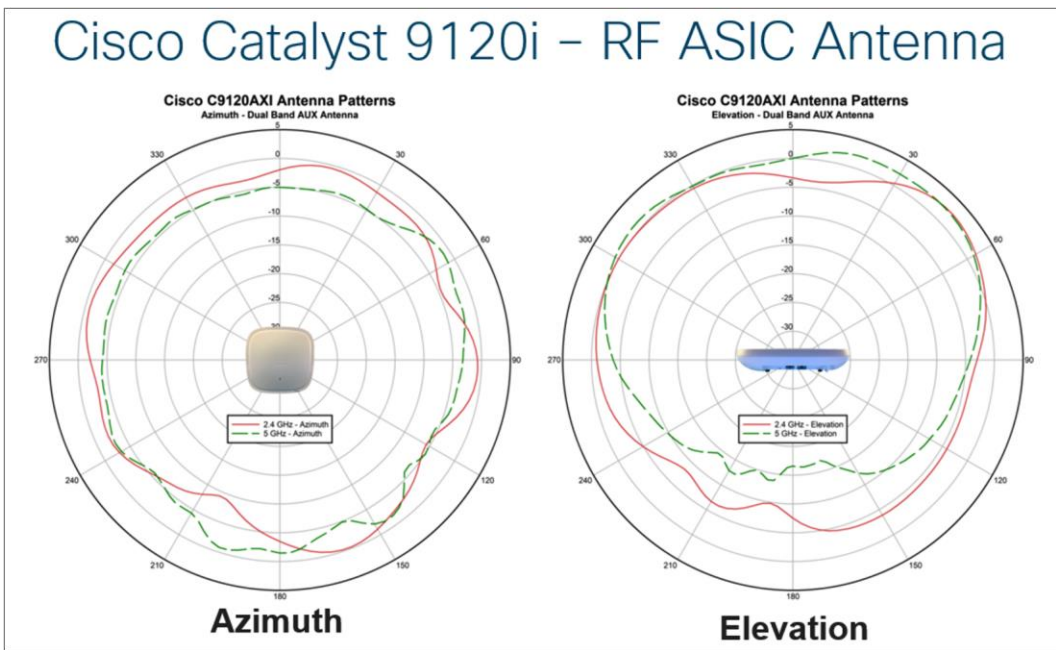

9120i RF ASIC antenna patterns

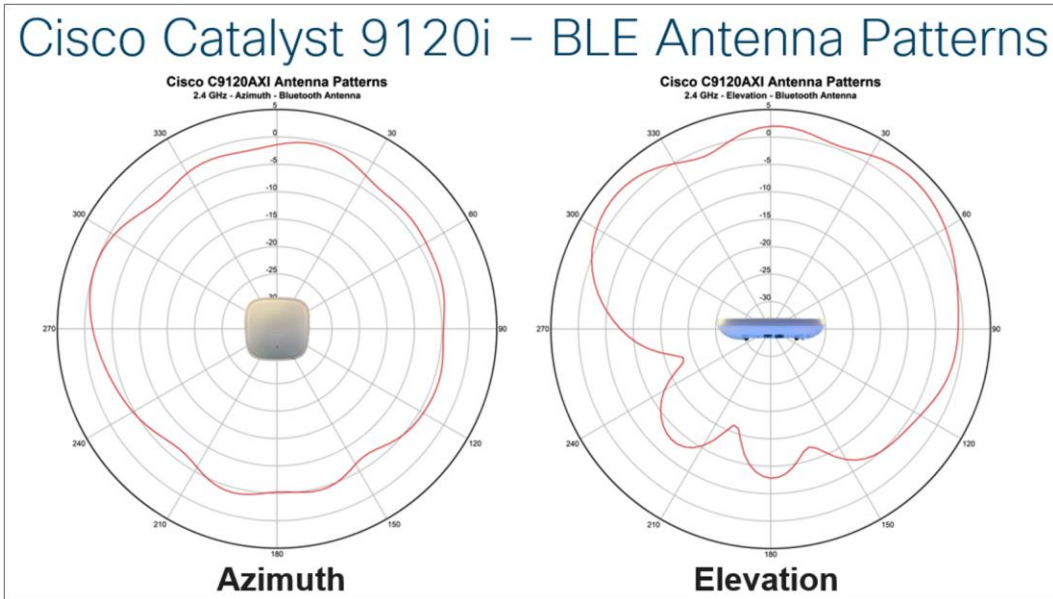
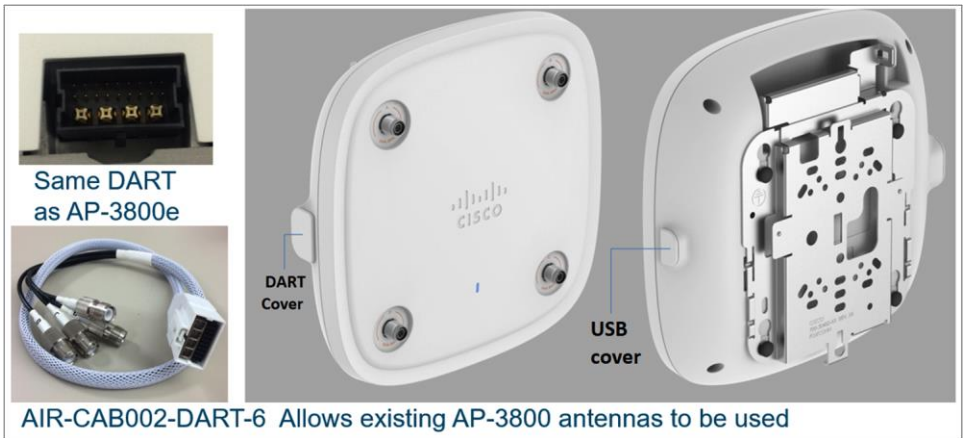

Figure – 9120i Bluetooth Low Energy (BLE) antenna patterns

Catalyst 9120e antenna system



9120e antenna system

Catalyst 9120e supports Dual 5 GHz on DART

DART connector allows for any combination of Macro & Micro Cells



When DART is not used AP is simply a Dual Band AP

When DART connector is inserted the 2.4 shuts off on top and secondary 5 GHz or if desired 2.4GHz RF goes out the DART connector



Supports both Omni and Directional Deployments



Supports directional antennas when the requirement is for two different coverage areas

9120e antenna system using the DART connector for dual 5 GHz

Co-Locating antennas and creating RF Isolation



You get isolation via several methods...

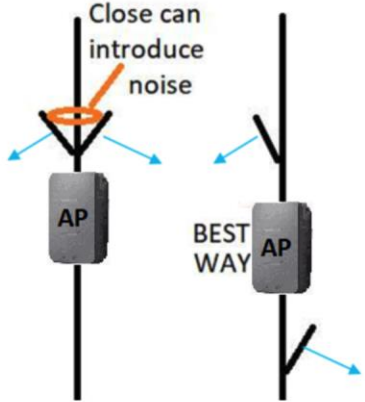





- Physical separation of the antennas
- Height separation of the antennas
- Antenna polarity separation
- Use of directional antennas so energy is focused away from each other
- Use of LOWER transmit power
- Use of frequencies that are further apart



Mount antennas away from each other whenever possible

Approved antennas Catalyst 9120e

Product ID	Description		Gain
AIR-ANT2524DB-R/=	2.4 GHz 2 dBi/5 GHz 4 dBi Dipole Ant., Black, connectors RP-TNC		2 dBi (2.4 GHz) 4 dBi (5 GHz)
AIR-ANT2524DG-R/=	2.4 GHz 2 dBi/5 GHz 4 dBi Dipole Ant., Gray, connectors RP-TNC		2 dBi (2.4 GHz) 4 dBi (5 GHz)

Product ID	Description		Gain
AIR-ANT2524DW-R=	2.4 GHz 2 dBi/5 GHz 4 dBi Dipole Ant. , White, connectors RP-TNC		2 dBi (2.4 GHz) 4 dBi (5 GHz)
AIR-ANT2535SDW-R	2.4 GHz 3 dBi/5 GHz 5 dBi Low Profile Antenna , White, connectors RP-TNC		3 dBi (2.4 GHz) 5 dBi (5 GHz)
AIR-ANT2566P4W-R=	2.4 GHz 6 dBi/5 GHz 6 dBi Directionnel Ant. , 4-port, connectors RP-TNC		6 dBi (2.4 GHz) 6 dBi (5 GHz)
AIR-ANT2524V4C-R=	2.4 GHz 2 dBi/5 GHz 4 dBi Ceiling Mount Omni Ant. , 4-port, connectors RP-TNC		2 dBi (2.4 GHz) 4 dBi (5 GHz)
AIR-ANT2544V4M-R=	2.4 GHz 4 dBi/5 GHz 4 dBi Wall Mount Omni Ant. , 4-port, connectors RP-TNC		4 dBi (2.4 GHz) 4 dBi (5 GHz)
AIR-ANT2566D4M-R=	2.4 GHz 6 dBi/5 GHz 6 dBi 60 Deg. Patch Ant. , 4-port, RP-TNC		6 dBi (2.4 GHz) 6 dBi (5 GHz)
AIR-CAB002-DART-R	Special connector for "e" series Flexible (XOR) radio to RP-TNC		Adapter

List of approved antennas

NOTE: These are all dual-band, dual-resonant antennas. **Do not use single-band antennas on this product** unless you choose to separate the AP into dedicated antennas (for example, dual 5 GHz or 5 GHz on top and 2.4 GHz on the DART). Single-band antennas need to be of the same gain and type as the antennas listed above and may not exceed 6 dBi on the 9120e Series.

For additional information on Cisco antennas, see the Cisco Antenna Reference Guide at this URL: <https://www.cisco.com/go/antenna-ref>.

Understanding Flexible Radio Assignment

The Catalyst 9120 contains a Flexible Radio Architecture (FRA). In a sense, the AP is a tri-band radio as it contains a dedicated 5-GHz radio to serve clients and another flexible radio (known as an XOR radio) that can be assigned different functions within the network. The flexible radio is similar to the previous XOR radio used in the Cisco Aironet AP-2800 and 3800 Series and is able to be configured to serve clients in either 2.4 or 5 GHz or serially scan both 2.4 and 5 GHz on the flexible radio while the main 5-GHz radio serves clients.

FRA and dual 5-GHz operations

Managing dual 5-GHz cells is one of the most important things that FRA does. There are two modes of operation for dual 5-GHz APs:

- Macro/Micro – A large cell with a smaller cell internal, creating double the capacity within the boundaries of a single cell.
- Macro/Macro – Dual independent 5-GHz cells, doubling the coverage of a single traditional dual-band AP. Macro/Macro is only supported on 9120e (as external antennas are used to accomplish this).

Macro/Micro is a use case applicable to the Catalyst 9120i models, as the internal antennas are designed to support a cell-within-a-cell deployment. In order for this to be effective, much design is committed to isolation of the two cells, starting at the silicon and ending with separation in antenna polarity and frequency separation.

FRA and Dynamic Channel Assignment (DCA) will enforce many configuration requirements when operating as dual 5-GHz Macro/Micro:

- Minimum 100-MHz channel separation (frequency diversity)
- Micro cell power is restricted to minimum
- Same Service Set Identifiers (SSIDs) on each cell

Having a Macro/Micro cell architecture is attractive because it solves the problem of having one large cell, in which a very diverse client experience exists. Clients closer to the AP are using higher data rates and enjoy a higher Signal to Noise Ratio (SNR) than will clients at the edge of the cell. Macro/Micro allows isolation of different clients within the cell that can serve them best and preserves airtime by increasing overall efficiency.

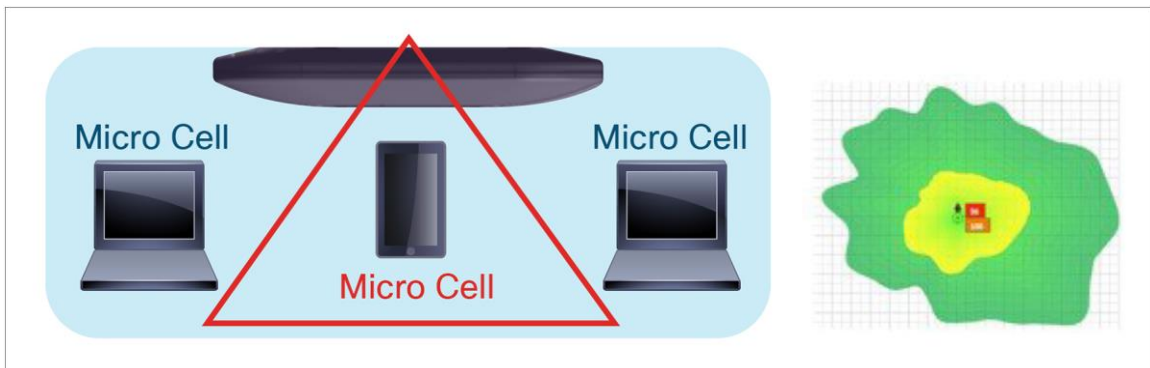

Picture of a Macro and Micro cell

Benefit – take-away

A dual 5-GHz-capable Catalyst 9120i creating Micro/Macro cells can perform much like two independent 5-GHz access points would using all the features and benefits of Wi-Fi 6.

When the Catalyst 9120i is operating in dual 5-GHz mode, clients get equal airtime, lower channel utilization rates, faster client-connected data rates, and less retries.

Single 5-GHz channel and dual 5-GHz channel

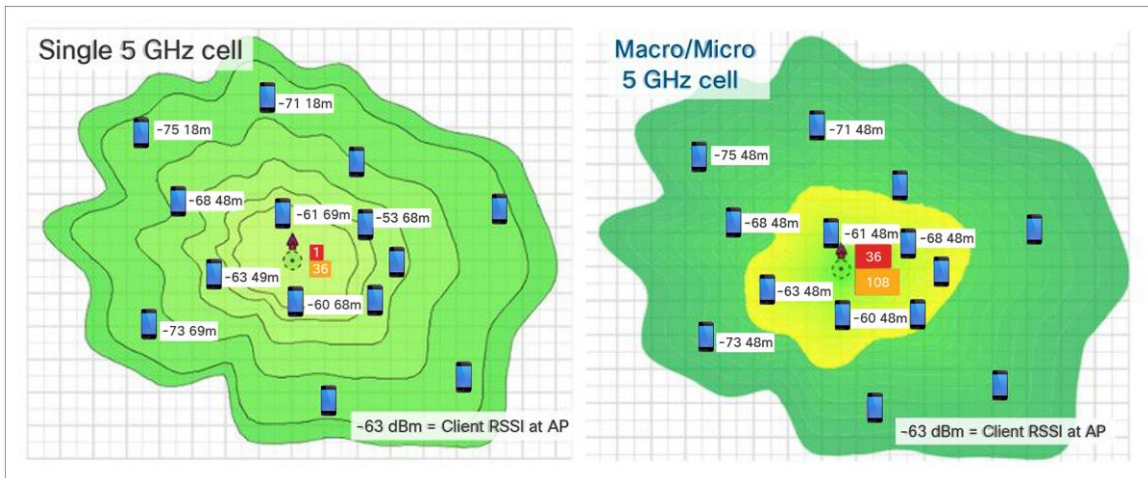

In the figure above, (on the left) a single channel cell, say channel 36, has a channel utilization of 60% because all clients are connected to that one channel. To make matters worse, they connect at nonuniform speeds, as the close-in clients connect much faster than the far-away clients.

(Left) Single-channel model – utilization is at 60% on channel 36

(Right) Dual-channel model – channel 36 drops to 20% and channel 108 is at 24%

Looking at the dual-channel model (on the right), by using two channels, the improvements become clear. This results in far less contention and less retries and a far better user experience. Note: This feature was first introduced in the 2800/3800 Series, which won Cisco's Pioneer Award for innovation in engineering design in 2017. This mode has a very big advantage for reducing channel utilization when combined with Wi-Fi 6 features that help with latency and small packets.

Take-away: Using dual 5GHz, users experience faster throughput, less retries, and a better Wi-Fi experience due to faster data rates and less channel utilization.

CleanAir spectrum analysis using Cisco's RF ASIC

Cisco CleanAir technology: a custom hardware/software solution.

To overcome the visibility limitations inherent to standard Wi-Fi chipsets, Cisco has created an integrated solution with patented chips and software that has been specifically designed to analyze and classify all RF activity. (More than 25 patents have been issued for this technology to date.)

Essentially, Cisco has taken the technology behind the Cisco Spectrum Expert analysis tool and integrated it directly into the infrastructure, including deep integration with a dedicated Software-Defined Radio (SDR) and a custom RF ASIC. This is a significant development and clearly demonstrates that wireless has transitioned from nice-to-have to business-critical in the enterprise.

The custom solution starts with the Cisco SAgE hardware core, which has been integrated directly into the Cisco RF ASIC custom silicon. The SAgE core handles very compute-intensive operations, such as high-resolution Fast Fourier Transform (FFT) and pulse detection operations. (A pulse is a burst of RF energy in frequency and time.) The SAgE core has a highly granular spectral resolution of 78.125 kHz (4x better than the nearest competitive solution and 64x better than most chipsets).

The RF ASIC provides the AP with an advanced and comprehensive interference analysis, detection, and mitigation system. Essentially, the SAgE core handles a base level of spectrum analysis operations that are so processing intensive that they can be prohibitive to handle in real-time software or by the serving radios.

Benefit – Comprehensive RF analysis and insight into the spectrum that no other competitor has, clearly identifying interference on a dedicated software-defined radio (separate from the client serving radios) so as to not impact access point client-serving performance.

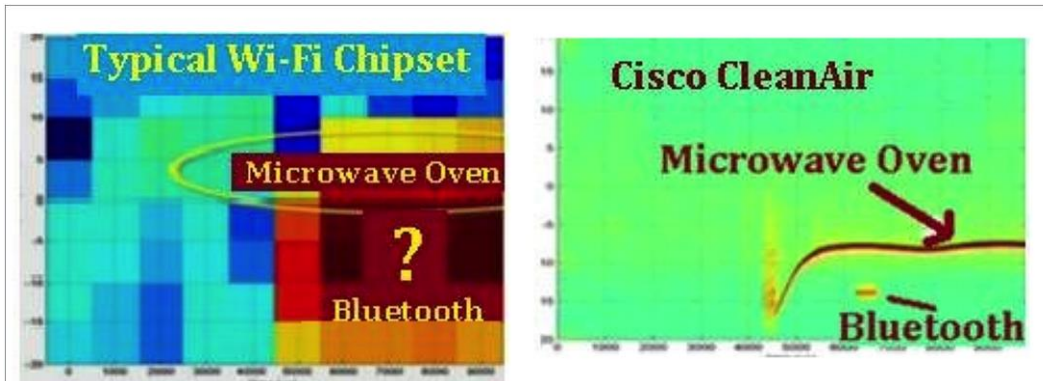

CleanAir clearly identifies the interference using dedicated radio and custom silicon

Dual DFS – RF ASIC

The RF ASIC and CleanAir chipset augments in the determination of DFS signals enhancing and reducing DFS false alerts so the AP can stay on a DFS channel more robustly. In addition to this, the dedicated radio participates in Cisco's RRM for interference mitigation and best channel selection.

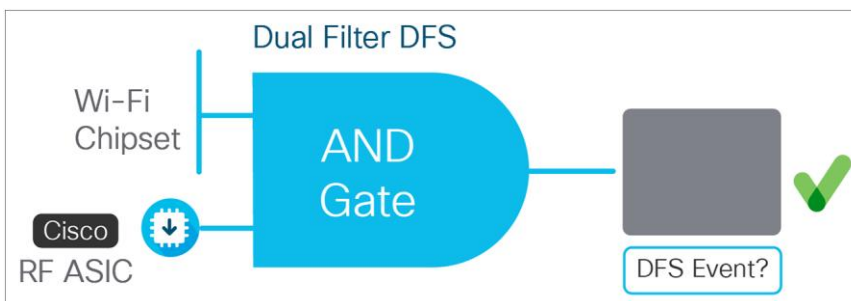

DFS event (detected by Wi-Fi chipset) is compared to RF ASIC to verify it is indeed a real DFS event

The RF ASIC is far more advanced than the DFS detection used by the Wi-Fi chipset and serves as a "second set of eyes" into the spectrum. The RF ASIC as a dedicated SDR will be enhanced further with new features as future software upgrades are released.

FastLocate - RF ASIC

Cisco CMX FastLocate technology enables quick location refresh for connected Wi-Fi clients. Readability Signal Strength Indicator (RSSI) from data packets and probe frames, when available, are used for calculating a location. This technology is available with both centrally switched WLANs and Cisco FlexConnect® (locally switched WLANs).

Benefit: The Catalyst 9120, with its onboard RF ASIC monitoring radio, enhances location by allowing access points on different client-serving channels to use the RF ASIC to listen to the probes and data packets on the Wi-Fi client of interest regardless of its channel.

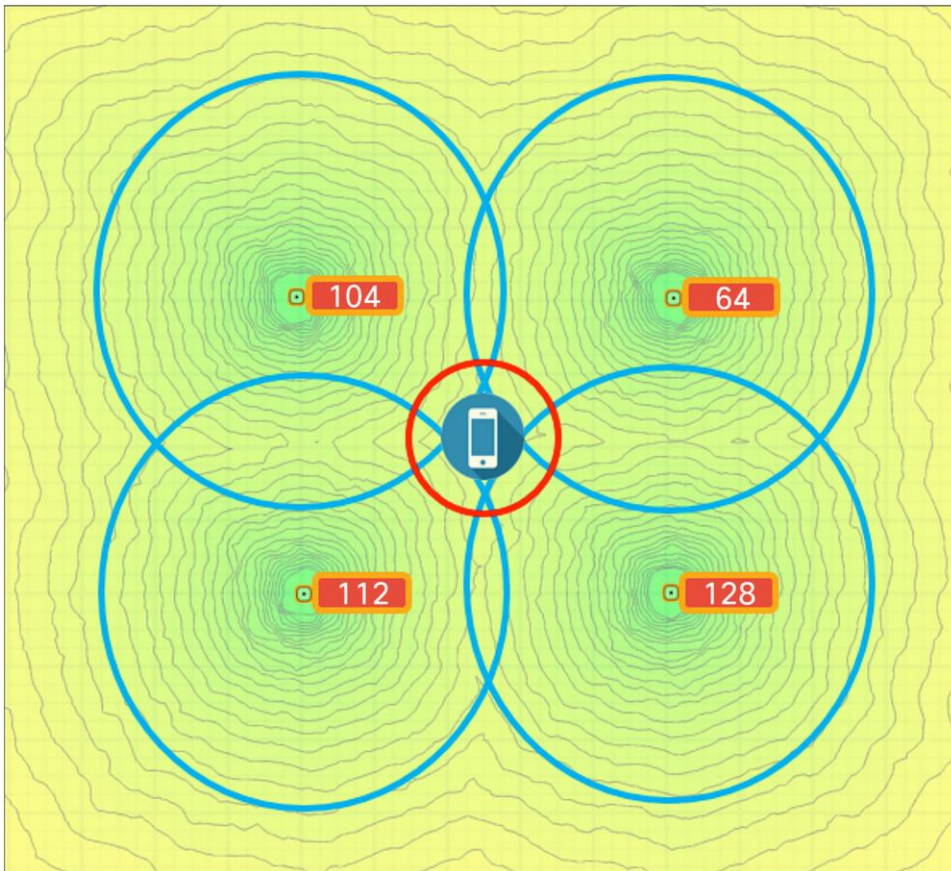

RF ASIC radio can track Wi-Fi clients regardless of the serving channel

Use cases

Manufacturing, warehouses, and factories

Warehouse installations are often difficult because of the very high ceilings and the clutter of the material being warehoused. When performing a coverage check (site survey), always check the coverage at “full stock” levels as the material being warehoused can change the RF coverage, creating loss of uniform coverage. Also, try to position the APs as close to the users as possible, perhaps lowering the antennas when possible or practical to do so. If the AP is 30 feet in the air, that is 30 feet farther the signal has to go, “best case.” When configuring coverage for aisles, try to use directional (patch) antennas on the wall and shoot down the aisles, or use low-gain omnidirectional antennas on the ceiling (such as dipoles) or units with integrated antennas as high-gain omnidirectional antennas tend to have more nulls.

Another option is to mount the AP lower using pipe and electrical box mounting techniques. Refer to the example shown in the picture below.



AP Placement in warehouse environment
(External dipole “e” series or internal antenna “i” series version could be used)

When mounting an AP at the end of a pipe or electrical conduit box, use the universal bracket Cisco AIR-AP-BRACKET-2, as it will mate to the holes of most electrical boxes. Conduit and adapters can be purchased at most electrical or home repair centers.

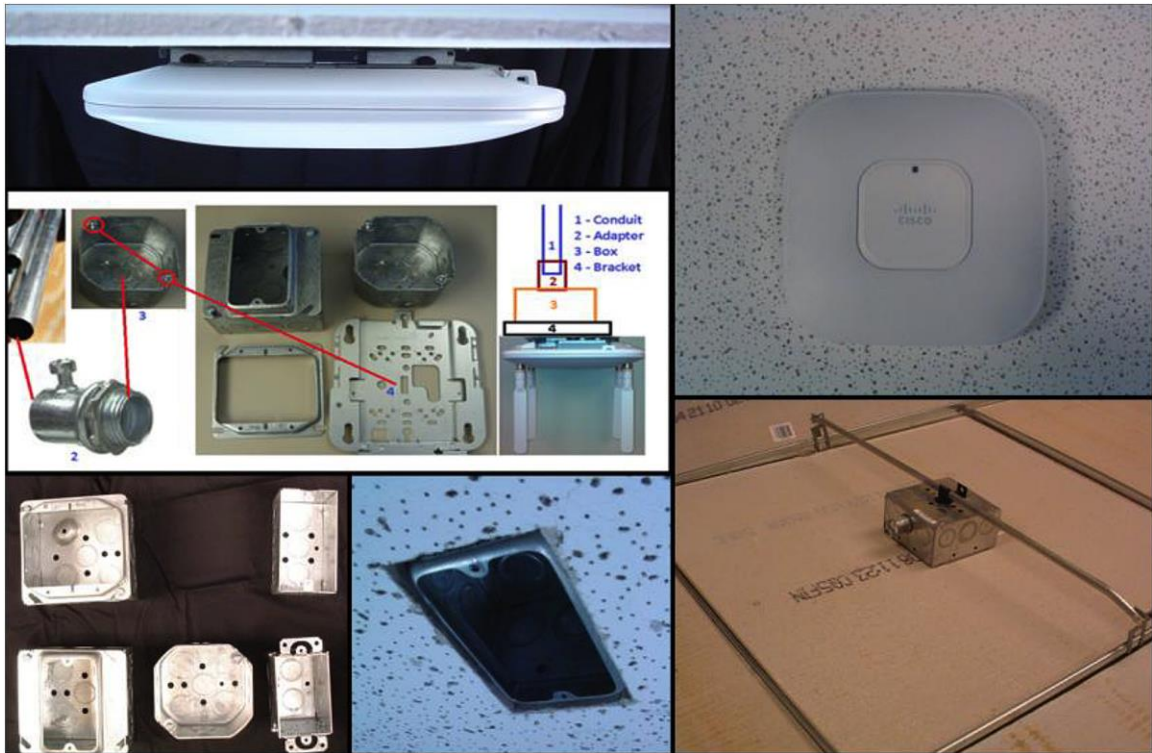

Mounting an AP onto an electrical conduit box (ceiling T-bar or conduit)

Use cases

Healthcare/clean rooms

If the Catalyst 9120 is used in a clean room, hospital, or other areas where the need for infection control requires the access point to be wiped down with a chemical, it is recommended that a ready-to-use sterilant such as Steris “Spor-Klenz” be used. Unlike some access points, the Catalyst 9120 does not have vent holes in the construction, so it may be wiped down. The plastics have been tested with this material.

<http://www.sterislifesciences.com/products/surface-disinfectants/sporicide-cleaners-and-sterilant/spor-klenz-ready-to-use-cold-sterilant>

If the healthcare environment requires metal ceilings or areas where tile is not practical, a metal enclosure from Oberon or AccelTex can be used.



Oberon metal enclosure protects and secures the AP in clean room areas

Use cases

Stadiums and harsh environments

Customers wishing to install the AP in harsh environments where it may be exposed to weather, such as sporting areas, stadiums, open garden areas, or warehouse freezers, may wish to use a NEMA-type enclosure.

Note: Some access points may not be certified for outdoor deployments in a NEMA enclosure. This varies around the world. For example, some regulatory agencies permit AP outdoor NEMA enclosures if the AP is indoors, such as in a freezer or garden area, but may prohibit its use outdoors. This seems to vary with weather radar compliance in different countries and often UNII-1 compliance. Check with your Cisco account team or the communications regulatory agency that has jurisdiction in your part of the world.



Example of an AccelTex 12x10x6 NEMA enclosure

Third-party sources for NEMA type enclosures and other accessories include:

www.oberonwireless.com/

www.acceltex.com/

www.terra-wave.com/

When using a NEMA-type enclosure, try to have the cables exit out of the bottom of the enclosure so that rain and moisture do not run down the cable into the enclosure. Also, the color of the enclosure may affect the heat rating. For example, a black enclosure gets much hotter in the sun than a white one. You may also want to use a pressure vent to prevent moisture accumulation.

Use cases

Education/schools

See the deployment guide at the following URL:

https://www.cisco.com/c/dam/en/us/td/docs/solutions/Verticals/Education/SRA_Schools/schoolSRA_wlan_sba.pdf

Use cases

Installations in Intermediate Distribution Frame (IDF) closets (telecommunications or other electrical equipment)

When installing APs near other electrical or telecommunications equipment, keep all wiring and metal away from the antennas and avoid placing the antennas near electrical lines. Do not route wiring electrical or Ethernet in the near field (6 to 15 inches) from the antenna. Try to refrain from installing the AP in the electrical closet, as the best place for the AP is as close to the users as possible or practical. If you must remote antenna cables from such a closet, you may be required to use plenum-rated cable (see local fire/safety regulations for more on this).

Below are a few URLs for understanding interference:

https://www.cisco.com/en/US/prod/collateral/wireless/ps9391/ps9393/ps9394/prod_white_paper0900aecd807395a9_ns736_Networking_Solutions_White_Paper.html

https://www.cisco.com/warp/public/cc/pd/witc/ao1200ap/prodlit/wrlan_wp.pdf

https://www.cisco.com/en/US/prod/collateral/wireless/ps5678/ps10981/white_paper_c11-609300.html

Use cases

Installations inside and around elevators

Elevator coverage can sometimes be accomplished by placing APs in the near field of the elevator, typically on each floor near the elevator door. Since elevators often have metal doors and the shafts are often concrete or contain other materials that degrade Wi-Fi coverage, it is important to check the coverage inside the elevator. While such coverage can be challenging, it is often doable, especially if the elevator is only a few floors.

High-rise elevators are more challenging since roaming issues are problematic as the client is cycling through a large number of APs rather quickly. Some companies that do in-elevator advertising have put a patch antenna on the floor inside the shaft and a patch antenna (or the actual AP) on the bottom of the elevator car, while other companies have used leaky coaxial cable running on the side of the shaft.

When installing any Wi-Fi equipment inside the elevator cars or shafts, local regulations need to be followed, as many times such installations are prohibited either for safety reasons or because the building owner or local fire department may prohibit them. Also, it is dangerous, and only elevator repair persons or contractors experienced with this kind of work should be in those areas. When the need for external antennas is a requirement, again position/use the Catalyst 9120e model.

WLAN best practices: Catalyst 9120

Access point antenna placement

The Catalyst 9120i access point has an advanced antenna system but correct placement of the AP is critical.



Coverage is optimized for ceiling placement and radiates omnidirectionally

General design guidelines: access point spacing recommendations

If you have a Wi-Fi device such as an AP and you are going to use another AP in the vicinity on a different channel, it is recommended that you space each AP apart by approximately 6 feet (2 meters). Avoid clustering the APs or the antennas from different APs together, as this could cause degradation in performance. This recommended distance is based on the assumption that both devices operate in the unlicensed band and do not transmit RF energy more than 23 dB - that is, 200 mW. If higher power is used, space farther apart.

Should you have other devices that transmit, especially if they operate in the same frequency ranges, for example, frequency-hopping legacy APs or other devices that operate close in frequency to those of the AP (think below or above the 2.4 and 5-GHz band), you should consider moving or separating the devices as far apart as can reasonably be done. After you have done this, check for interference by testing both devices at the same time under heavy utilization (load) and then characterize each system independently to see how much, if any, degradation exists.



Warning

In order to comply with FCC, EU, and EFTA RF exposure limits, antennas should be located at a minimum of 7.9 inches (20 centimeters) or more from the body of all persons. See the installation guide under declaration of conformity for more on this.

Mixing access points of different models and types

The Catalyst 9120 is a very advanced access point supporting Wi-Fi 6 features along with unique features such as dual 5 GHz and advanced RF detection using Cisco custom RF ASIC silicon.

For this reason, it is not recommended that you mix access point models, sometimes called “salt and pepper,” as it would diminish the performance of the Cisco DNA network, degrading many of our advanced features and perhaps introducing a suboptimal performance.

For this reason, if you have a mixture of AP types, it is recommended that you group like access points together (for example, AP-3800s on, say, one floor and Cisco Catalyst 9120s on another) and refrain from mixing them.

Catalyst 9120 general placement guidelines

The following are some guidelines to remember regarding access point installations.

1. Always try to mount the AP as close to the users as possible for best performance. Be aware of the environment (for example, hospitals have metal doors, coverage can change when the doors close, old buildings can have metal grid work in the plaster or asbestos). Avoid mounting the AP or antennas near metal objects, as doing so can change the coverage area affecting clients.
2. When using the 2.4-GHz frequency, the same 1-, 6-, and 11-channel scheme is used as is the 5-GHz channel scheme. Avoid putting all of the APs on the same channel, and reuse channels as you can.
3. Cisco RRM, FRA, and other features can help automate the process.
4. Try to determine which clients are heavily used, checking the coverage with those clients. For example, a PDA or Wi-Fi phone might not have the same range as a notebook or tablet.



Tip

Verify coverage using the worst-performing clients that you intend to deploy.

- While site surveys are highly recommended, if the design is done at half power and Cisco RRM is in place, sometimes a limited site survey (coverage check) is adequate for smaller venues. If this is a very challenging environment, such as train connectivity, gas and oil verticals, or large hospitals, Cisco has an Advanced Services team that can be contracted to help you get up to speed or perform your installation. See your Cisco account team for more information.

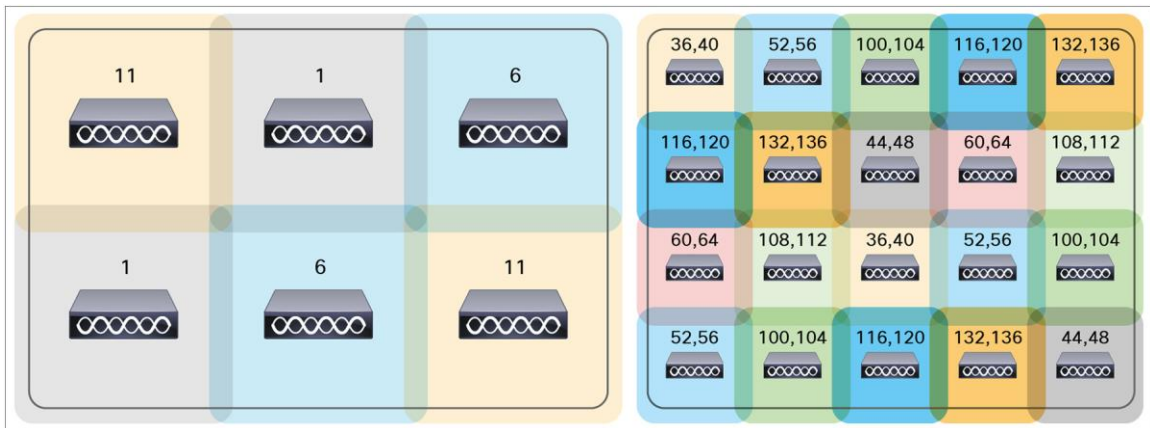

Example of a channel coverage model spacing nonoverlapping channels

Antenna cable recommendation

Whenever practical or possible, please keep antenna cable runs as short as possible. Cisco offers Low Loss (LL) and ultralow loss (ULL) cables, which have the same characteristics as Times Microwave LMR-400 and LMR-600.

Cisco cables carry the part number AIR-CAB (Aironet Cable) and then a length. For example, a 20-ft length of LL cable with RP-TNC connector is Cisco AIR-CAB-020LL-R. These heavy black cables are not plenum rated and are primarily for outdoor use or manufacturing areas.



When drilling holes for cable, allow for the size of the connector (typically 5/8 inch) drill bit

Wi-Fi 6 installations and site survey considerations

What do you have installed today? Now is the time to evaluate your WLAN needs.

- Before refreshing to Wi-Fi 6, its time to do a review of your existing WLAN issues as well as identifying any new location, BLE, or IoT requirements.
- 1:1 replacement assumes the AP was installed in the best place to meet your current coverage and density goals.
- Do you have any coverage issues today that you have not addressed?

- Are there any poorly mounted or suboptimal installations?
- Ideally you should have at least 802.3at (30W PoE) available.
- Wi-Fi 6 might help mitigate a poor design, but nothing beats installing it right the first time.

There are many tools out there to model and perform site surveys. Cisco has recently worked with Ekahau to import Cisco APs and antenna models into their application, which also includes the ability to model BLE as well. The Catalyst 9120 AP model will be in the next maintenance release (current is 10.0.1).



Ekahau offers a site survey and WLAN planner software

If you are doing an active survey for placement, it is always best to have the equipment you plan to deploy. Having the actual model that is being planned for is not always possible at the time that planning is being done. Cisco spends a great deal of effort to ensure that newer-model AP's RF coverage matches closely with previous models of APs to reduce the cost of planning and replacing APs. The C9120 is no different. The below graphic shows the C9120 as compared with the AP3802i on the same channel and power, as an example only. Surveying using an alternate AP is suitable for Bill of Material (BOM) generation or updates to an existing installation. Critical coverage should always be measured using the same model to be certain of the results.

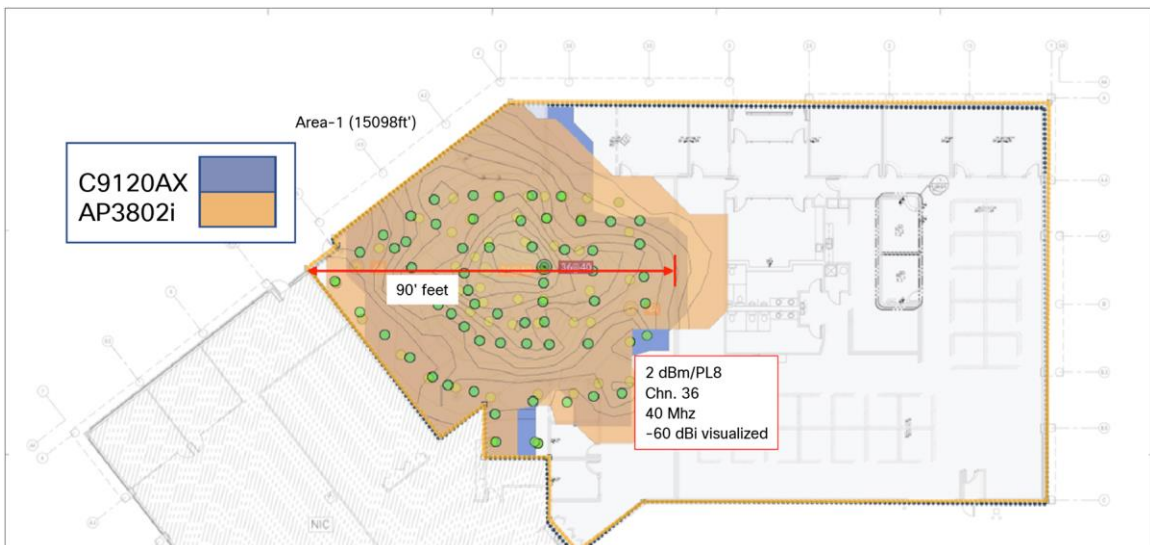

Comparison of C9120 and AP3802i coverage patterns as measured over the air

If the building is not wired for Ethernet and you need to power a Catalyst 9210 from a battery, AccelTex offers a battery pack that can be used.



AccelTex site survey battery pack P/N ATS-SSBP-1

Appendix

Useful URLs within the guide:

1. Cisco CleanAir white paper: https://www.cisco.com/c/en/us/solutions/collateral/enterprise-networks/cleanair-technology/white_paper_c11-599260.html
2. Flexible radio assignment and dual 5-GHz operation:
https://www.cisco.com/c/en/us/td/docs/wireless/controller/technotes/8-3/b_RRM_White_Paper/b_RRM_White_Paper_chapter_01000.html
3. Flexible radio Cisco Aironet 2800/3800 deployment guide:
https://www.cisco.com/c/en/us/td/docs/wireless/controller/technotes/8-3/b_cisco_aironet_series_2800_3800_access_point_deployment_guide.pdf
4. Cisco multigigabit mGig overview along with supported switches:
<https://www.cisco.com/c/en/us/solutions/enterprise-networks/catalyst-multigigabit-switching/index.html>
5. Cisco DNA architecture overview: <https://www.cisco.com/c/dam/en/us/solutions/collateral/enterprise-networks/cisco-digital-network-architecture/solution-overview-c22-736580.pdf>



Americas Headquarters
Cisco Systems, Inc.
San Jose, CA

Asia Pacific Headquarters
Cisco Systems (USA) Pte. Ltd.
Singapore

Europe Headquarters
Cisco Systems International BV Amsterdam,
The Netherlands

Cisco has more than 200 offices worldwide. Addresses, phone numbers, and fax numbers are listed on the Cisco Website at <https://www.cisco.com/go/offices>.

 Cisco and the Cisco logo are trademarks or registered trademarks of Cisco and/or its affiliates in the U.S. and other countries. To view a list of Cisco trademarks, go to this URL: <https://www.cisco.com/go/trademarks>. Third-party trademarks mentioned are the property of their respective owners. The use of the word partner does not imply a partnership relationship between Cisco and any other company. (1110R)