

INSTALLATION, OPERATING AND SERVICE INSTRUCTIONS FOR

V1™ RO or FO SERIES OIL - FIRED BOILER



SECTION I - GENERAL INFORMATION..... Page 3
 SECTION II - INSTALLATION INSTRUCTIONS Page 4
 SECTION III - OPERATING AND SERVICE INSTRUCTIONS Page 11
 SECTION IV - CLEANING OF BOILER Page 16
 SECTION V - REPAIR PARTS Page 18

NOTE: For optimum performance and serviceability from this boiler adhere to the following recommendations:

- 1 - Clean Flueways at least once a year - preferably at the end of heating season to remove soot and scale. Inside of firebox should also be cleaned at the same time.
- 2 - Have oil burner and controls checked at least once a year or as may be necessitated.
- 3 - Retain your contractor or a competent service agency to assure that the boiler is properly adjusted and maintained.

IMPORTANT: BEFORE STARTING TO INSTALL THIS OIL FIRED BOILER, READ THESE INSTRUCTIONS CAREFULLY. KEEP INSTRUCTIONS NEAR BOILER FOR REFERENCE BY OWNER AND SERVICEMAN.

For service or repairs to boiler, call your heating contractor or oil supplier. When seeking information on boiler, provide Boiler Model Number and Serial Number as shown on Rating Label located on top of the boiler.

Boiler Model Number V1 _ R_ -TB	Boiler Serial Number	Installation Date
Heating Contractor		Phone Number
Address		



IMPORTANT INFORMATION - READ CAREFULLY

1. THIS BOILER HAS A LIMITED WARRANTY, A COPY OF WHICH IS PRINTED ON THE BACK PAGE OF THIS MANUAL.
2. THIS BOILER IS SUITABLE FOR INSTALLATION ON COMBUSTIBLE FLOORING.
3. ALL BOILERS MUST BE INSTALLED IN ACCORDANCE WITH NATIONAL, STATE AND LOCAL PLUMBING, HEATING AND ELECTRICAL CODES AND THE REGULATIONS OF THE SERVING ELECTRICAL, WATER AND GAS UTILITIES WHICH MAY DIFFER FROM THIS MANUAL.
4. ALL HEATING SYSTEM SHOULD BE DESIGNED BY COMPETENT CONTRACTORS AND ONLY PERSONS KNOWLEDGEABLE IN THE LAYOUT AND INSTALLATION OF HYDRONIC HEATING SYSTEMS SHOULD ATTEMPT INSTALLATION OF ANY BOILER.
5. THE BOILER MUST BE CONNECTED TO AN APPROVED CHIMNEY IN GOOD CONDITION. SERIOUS PROPERTY DAMAGE COULD RESULT IF THE BOILER IS CONNECTED TO A DIRTY OR INADEQUATE CHIMNEY. THE INTERIOR OF THE CHIMNEY FLUE MUST BE INSPECTED AND CLEANED BEFORE THE START OF THE HEATING SEASON AND SHOULD BE INSPECTED PERIODICALLY THROUGHOUT THE HEATING SEASON FOR ANY OBSTRUCTIONS. A CLEAN AND UNOBSTRUCTED CHIMNEY FLUE IS NECESSARY TO ALLOW NOXIOUS FUMES THAT COULD CAUSE INJURY OR LOSS OF LIFE TO VENT SAFELY AND WILL CONTRIBUTE TOWARD MAINTAINING THE BOILER'S EFFICIENCY.
6. READ THE LITERATURE ENCLOSED BY THE MANUFACTURER WITH THE VARIOUS ACCESSORY DEVICES. THESE ACCESSORY DEVICES MUST BE INSTALLED AND USED ACCORDING TO THE RECOMMENDATIONS OF THE MANUFACTURER.
7. IT IS THE RESPONSIBILITY OF THE INSTALLING CONTRACTOR TO SEE THAT ALL CONTROLS ARE CORRECTLY INSTALLED AND ARE OPERATING PROPERLY WHEN THE INSTALLATION IS COMPLETED.
8. FOR OPTIMUM PERFORMANCE AND SERVICEABILITY FROM THIS UNIT ADHERE TO THE FOLLOWING RECOMMENDATIONS:
 - A. Clean Flueways at least once a year - preferably at the end of the heating season to remove soot and scale. Inside of Firebox should also be cleaned at the same time.
 - B. Have Oil Burner and Controls checked at least once a year or as may be necessitated.
 - C. Retain your contractor or a competent serviceman to assure that the unit is properly adjusted and maintained.
9. IN ALL CASES, TYPE OF VENTING MATERIAL AND CLEARANCES BETWEEN BOILED AND /OR SMOKE PIPE SURFACES AND COMBUSTIBLE MATERIALS MUST COMPLY WITH CURRENT EDITION OF AMERICAN NATIONAL STANDARD ANSI/NFPA 211.
10. ALL FLAMMABLE DEBRIS, RAGS, PAPER, WOOD SCRAPS, ETC., SHOULD BE KEPT CLEAR OF THE BOILER AT ALL TIMES. KEEP THE BOILER AREA CLEAN AND FREE OF FIRE HAZARDS.

WARNING

High water temperatures increase the risk of burns or scalding injury. Install an automatic tempering (mixing) valve at the tankless heater outlet to avoid excessively hot water at the fixtures.

IMPORTANT

Before starting to install this oil boiler, read these instructions carefully. Keep instructions in legible condition and posted near oil boiler for reference by owner and service technician.

SECTION I: GENERAL INFORMATION

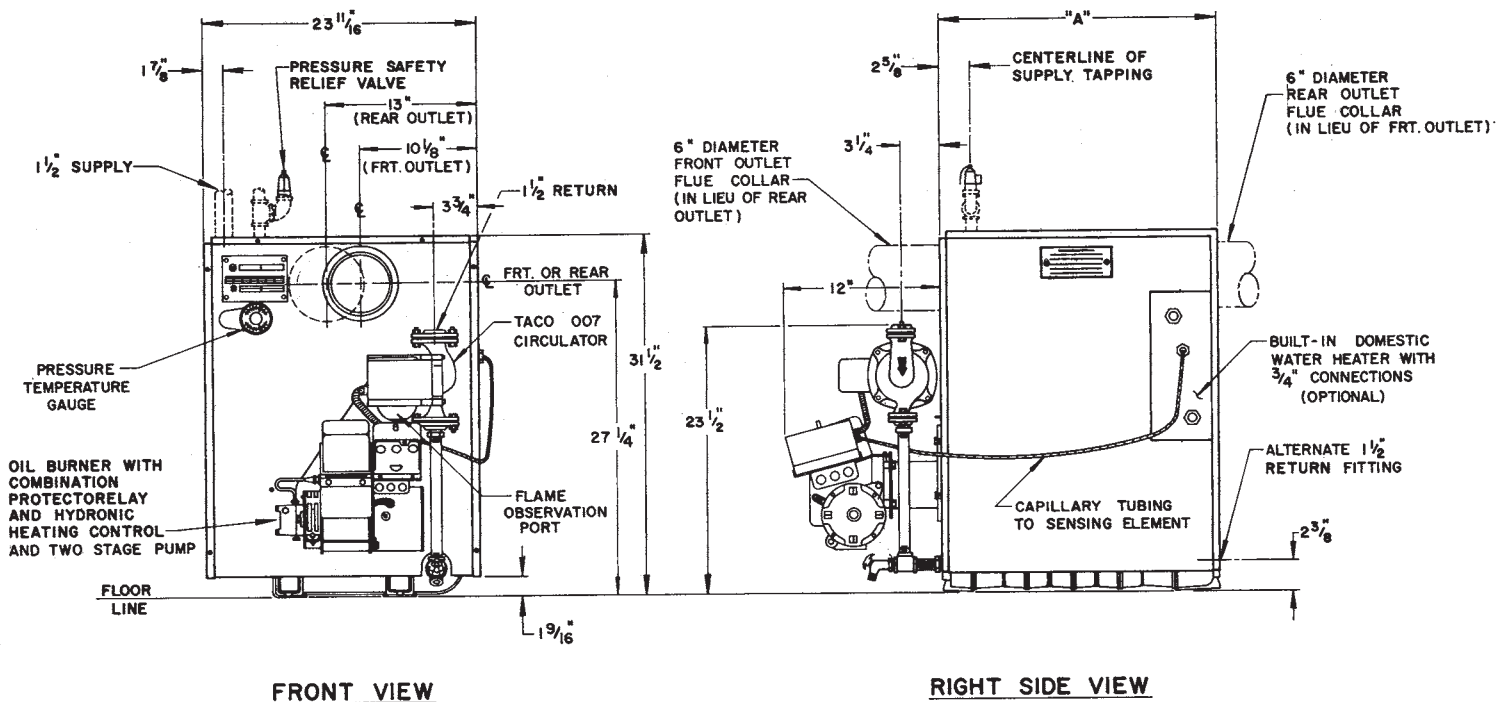

Figure: 1

- A. INSPECT SHIPMENT** carefully for any signs of damage.
1. ALL EQUIPMENT is carefully manufactured, inspected and packed. Our responsibility ceases upon delivery of created Boiler to the carrier in good condition.
 2. ANY CLAIMS for damage or shortage in shipment must be filed immediately against the carrier by the consignee. No claims for variances from, or shortage in orders, will be allowed by the manufacturer unless presented within sixty (60) days after receipt of goods.
- B. LOCATE BOILER** in front of final position before removing crate. See Figure 1.
1. LOCATE so that smoke pipe connection to chimney will be short and direct. BOILER IS SUITABLE FOR INSTALLATION ON COMBUSTIBLE FLOOR.
 2. FOR BASEMENT INSTALLATION, provide a concrete base if floor is not perfectly level, or if water may be encountered on floor around Boiler.
 3. PROVIDE CLEARANCE of at least 24" on right side of Boiler for cleaning flueways and for removal of Tankless Heater. Provide clearance of at least 14" in front (measured from front jacket panel) for servicing burner.

Table 1: Dimensional Data

Model No.	Firing Rate (GPH)	Dimension - Inches			Chimney size In. x In. x Ft.	Approx. Shipping Weight (LB)
		"A"	"B"	"C"		
V13RO/FO	0.75	15-7/8	7-1/4	6	8 x 8 x 15	519
V14RO/FO	1.05	19-7/8	9-1/4			603

NOTE: Maximum Working Pressure - 30 PSI (Water Only)

- C. PROVIDE AIR SUPPLY AND VENTILATION** to accommodate proper combustion. If natural ventilation is inadequate, provide a screened opening from the Boiler Room to the outside. Free area thru screening must be equal to area of flue pipe. If other air consuming appliances are near the boiler, the air inlet should be larger. Consult respective manufacturers.
- D. REMOVE CRATE -**
1. Remove all fasteners at crate skid.
 2. Lift outside container and remove with all other inside protective spacers and bracing. Remove container containing Barometric Stabilizer, Safety Relief Valve and fittings and Boiler Drain Valve.

SECTION II: INSTALLATION INSTRUCTIONS

A. REMOVAL OF BOILER FROM SKID

1. Boiler is secured to base with 4 bolts, 2 on left side and 2 on right side, see Figure 2. Remove all bolts.
2. Tilt boiler to right and to rear. Using right rear leg as pivot, rotate boiler 90° in a clockwise direction, and lower left side of boiler to floor. Tilt boiler and remove crate skid. Care should be exercised to prevent damage to Jacket or Burner.

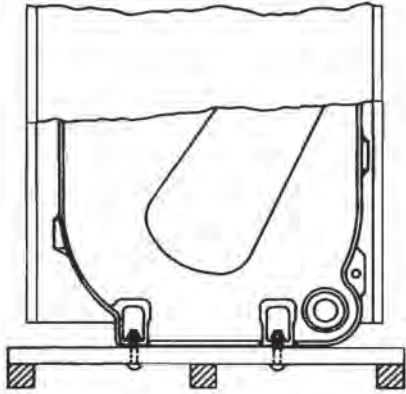

Figure 2:

B. MOVE BOILER TO PERMANENT POSITION by sliding or walking.

C. INSPECT COMBUSTION TARGET WALL.

1. OPEN FLAME OBSERVATION DOOR on front of boiler.
2. Use flashlight to inspect Target Wall secured to rear section with silastic. If damaged, replace.

D. INSTALL CANOPY

The canopy is shipped in a separate carton.

1. Open canopy carton and remove canopy.
2. Remove two (2) sheet metal screws at the front (4) sheet metal screws on the upper end of the side panels and swing jacket top panel upward as shown in Figure 3, Step 1.
3. Check that cerafelt gasket is in place on top of the cast iron block.
4. Using screwdriver and pliers, remove the 6½" knock out from the rear panel, AS SHOWN IN Figure 3, Step 2.
5. Insert the canopy onto the top of the block and fasten with the four (4) bolts and nuts provided as shown in Figure 3, Step 3. Be sure that the canopy tightens evenly onto the cerafelt gasket.

NOTE: Canopy is provided with a removable cover for inspection and cleaning of the chimney breeching, as necessary in confined installations.

6. Before replacing jacket top panel, determine if future access to the chimney breeching through the canopy opening is anticipated. If so, cut along perforated bend line to separate jacket top panel from the rear panel as shown in Figure 3, Step 4. Close or replace top panel and secure with sheet metal screws removed in (b) above.

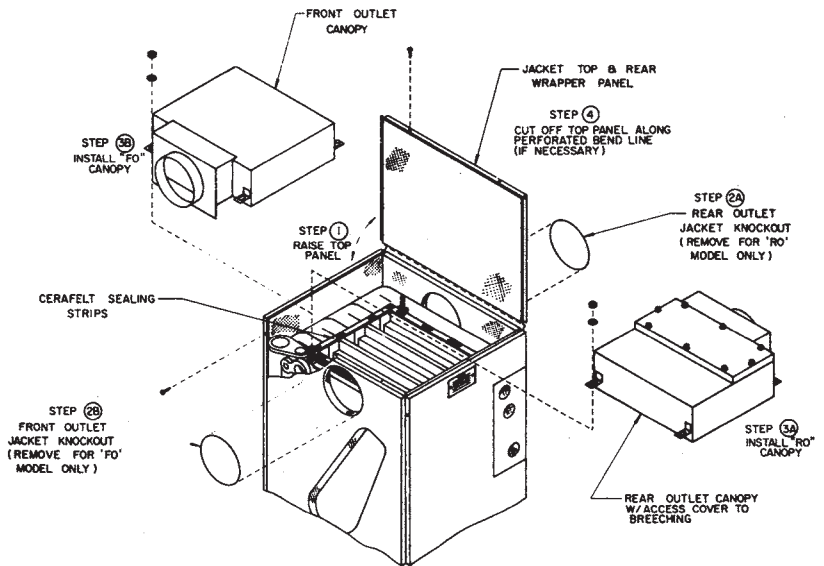

Figure 3: Installation of Canopy
(See text for proper procedure)

E. CONNECT SUPPLY AND RETURN PIPING TO HEATING SYSTEM.

CLEARANCES - Hot water pipes shall have clearances of at least ½" from all combustible construction.

1. For Forced Circulation HOT WATER HEATING, refer to Figure 4 for recommended boiler piping. Consult I=B=R Installation & Piping Guide No. 200.
2. Plug lower rear 1½" tapping if it is not to be used.
3. Install relief valve and fittings in top of front section, see Figure 1.

CAUTION: OXYGEN CORROSION

Oxygen contamination of the boiler water will cause corrosion of the iron and steel boiler components, which can lead to failure. As such, any system must be designed to prevent oxygen absorption in the first place or prevent it from reaching the boiler. Problems caused by oxygen contamination of boiler water are not covered by Burnham's standard warranty.

There are many possible causes of oxygen contamination such as:

- a. Addition of excessive make-up water as a result of system leaks.
- b. Absorption through open tanks and fittings.
- c. Oxygen permeable materials in the distribution system.

In order to insure long product life, oxygen sources should be eliminated. This can be accomplished by taking the following measures:

- a. Repairing system leaks to eliminate the need for addition of make-up water.
- b. Eliminating open tanks from the system.

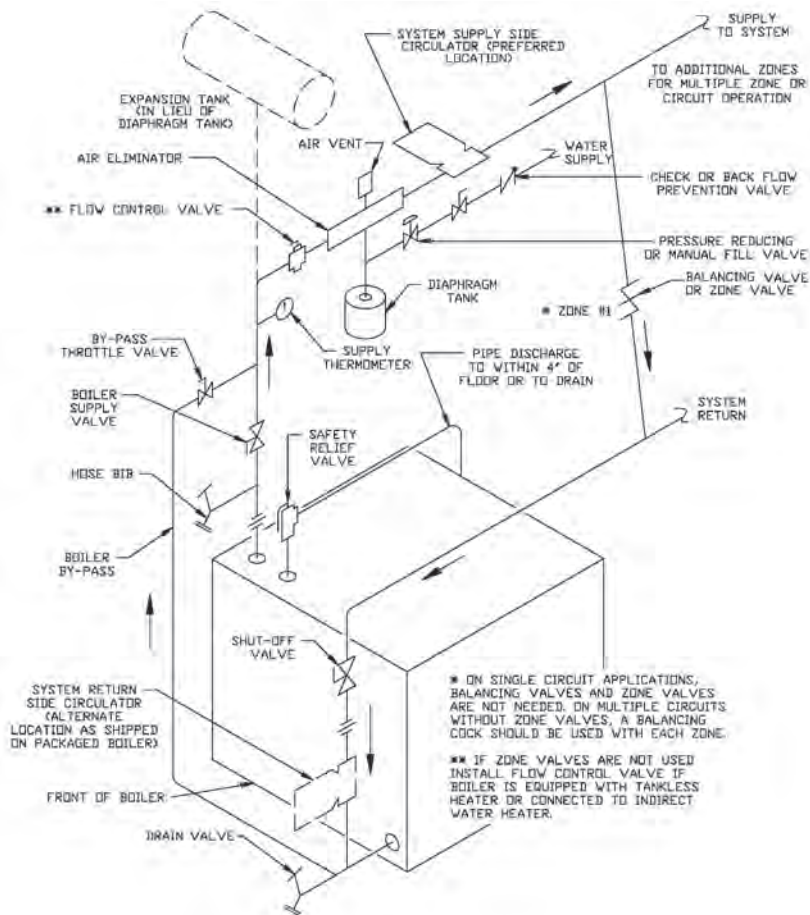

Figure 4: Recommended Water Piping for Zone Valve Zoned Heating Systems

- c. Eliminating and/or repairing fittings which allow oxygen absorption.
 - d. Use of non-permeable materials in the distribution system.
 - e. Isolating the boiler from the system water by installing a heat exchanger.
4. If Tankless Heater is not used and if the boiler is to be operated in a system which has a large volume or excessive radiation where low boiler water temperatures may be encountered (i.e. converted gravity circulation system, etc.) the use of a boiler water bypass is recommended to maintain optimum operation.

Remove the circulator and install a pipe tee between the circulator and boiler return along with a second tee in the supply piping as shown in Figure 5. The bypass should be the same size as the supply and return lines with valves located in the bypass and supply outlet as illustrated in Figure 5 in order to regulate water flow to maintain higher boiler water temperatures.

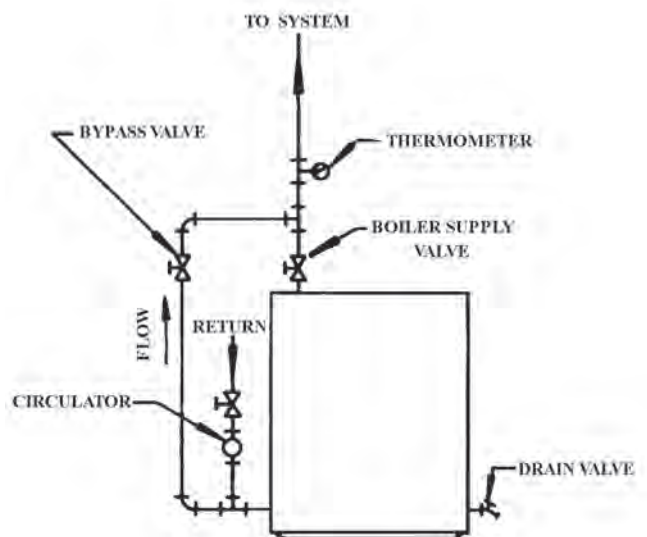

Figure 5: Recommended Bypass Piping for V13 RO/FO & V14 RO/FO

Set the by-pass and boiler supply valves to a half throttle position to start. Operate boiler until the system water temperature is at a normal operating range.

Adjust the valves to provide 180° to 200°F supply water temperature. Opening the boiler supply valve will raise the system temperature, while opening the by-pass valve will lower the system supply temperature.

5. If this boiler is used in connection with refrigeration systems, the boiler must be installed so that the chilled medium is piped in parallel with the heating boiler using appropriate valves to prevent the chilled medium from entering the boiler, see Figure 6. Also consult I=B=R Installation and Piping Guides.
6. If this boiler is connected to heating coils located in air handling units where they may be exposed to refrigerated air the boiler piping must be equipped with flow control valves to prevent gravity circulation of boiler water during the operation of the cooling system.

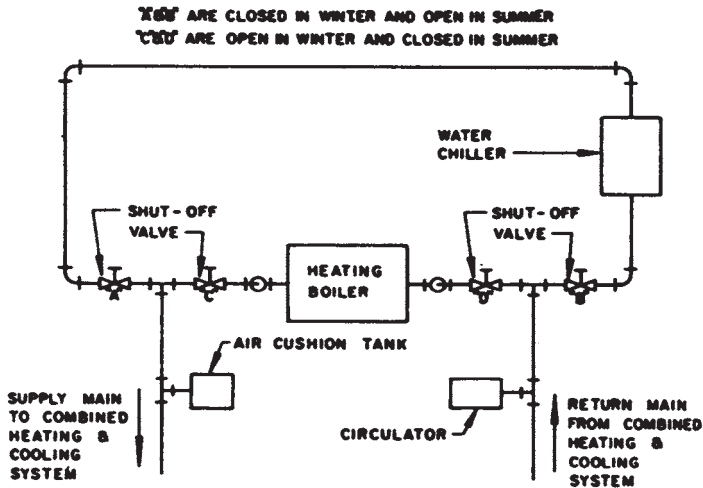

Figure 6: Recommended Piping for Combination Heating & Cooling (Refrigeration) System

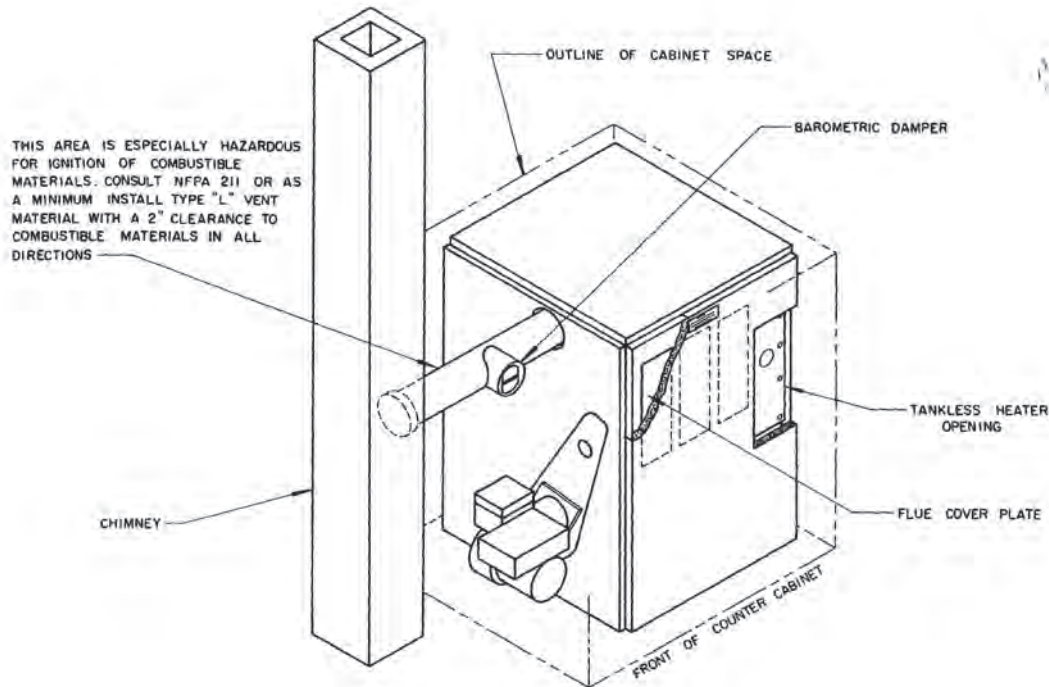

Figure 7: Installation of FO in a Confined Space with Adjacent Chimney

NOTE:

1. Type L Vent Material generally means stainless steel inner liner and stainless steel outer covering and separated with 1" thick special high temperature insulation - factory assembled and rated.
2. In a confined space, provide ventilation air to the burner and size such ventilation air openings to provide not less than 28 square inches free area per gallon of fuel input to the burner.
3. Keep right side of boiler accessible for flue cleanout and tankless coil maintenance.
4. Boiler is heavily insulated and is suitable for 1" clearance from jacket surface to combustibles.
5. Boiler is of wet base design and suitable for installation on combustible floors.
6. The original installation may have been under poor or outdated building codes. Replacement boilers are subject to codes in effect at the time of replacement. Be sure to consult with local code officials before starting replacement.

IMPORTANT

7. A hot water boiler installed above radiation level must be provided with a low water cutoff device as part of the installation.

If a low water cut-off is required, it must be mounted in the system piping above the boiler. The minimum safe water level of a hot water boiler is just above the highest water containing cavity of the boiler; that is, a hot water boiler must be full of water to operate safely.

If it is required to perform a long term pressure test of the hydronic system, the boiler should first be isolated to avoid a pressure loss due to the escape of air trapped in the boiler.

To perform a long term pressure test including the boiler, ALL trapped air must first be removed from the boiler.

A loss of pressure during such a test, with no visible water leakage, is an indication that the boiler contained trapped air.

- F. **INSTALL BREECHING.** For normal installation in a large confined space refer to local codes for proper selection of the breeching materials.

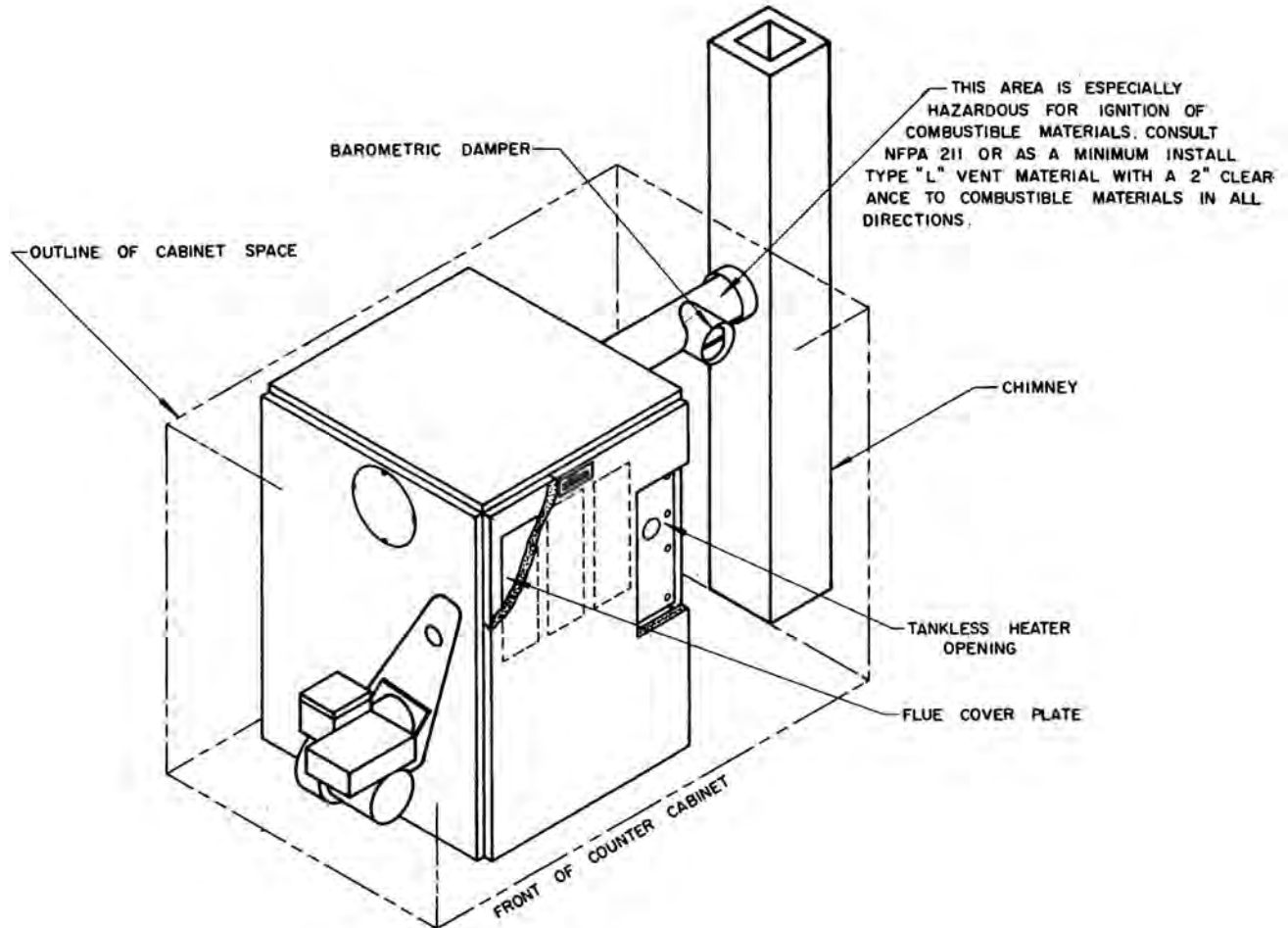

Figure 8: Installation of RO in a Confined Space with Adjacent Chimney

NOTE:

1. Type L Vent Material generally means stainless steel inner liner and stainless steel outer covering and separated with 1" thick special high temperature insulation - factory assembled and rated.
2. In a confined space, provide ventilation air to the burner and size such ventilation air openings to provide not less than 28 square inches free area per gallon of fuel input to the burner.
3. Keep right side of boiler accessible for flue cleanout and tankless coil maintenance.
4. Boiler is heavily insulated and is suitable for 1" clearance from jacket surface to combustibles.
5. Boiler is of wet base design and suitable for installation on combustible floors.
6. The original installation may have been under poor or outdated building codes. Replacement boilers are subject to codes in effect at the time of replacement. Be sure to consult with local code officials before starting replacement.

For installation in a confined space such as an under-counter installation, special consideration must be given to the selection of breaching material. The temperature within the confined space will be higher than in the normal installation. One major source of those higher temperature is the exposed breaching within the confined space. Thus, it is required that any exposed breaching be constructed of type "L" are equivalent vent material.

Furthermore, the likelihood of accidental ignition of combustibles within 12" of the breaching is increased when the boiler is installed in a confined space. This is due to the lack of free air movement over the surfaces to cool them. For this reason THE ENTIRE LENGTH OF BREECHING FROM THE OUTLET OF THE BOILER TO THE CHIMNEY MUST BE INSTALLED ACCORDING TO NFPA 211, OR LOCAL CODES. Refer to Figures 7, 8 and 9.

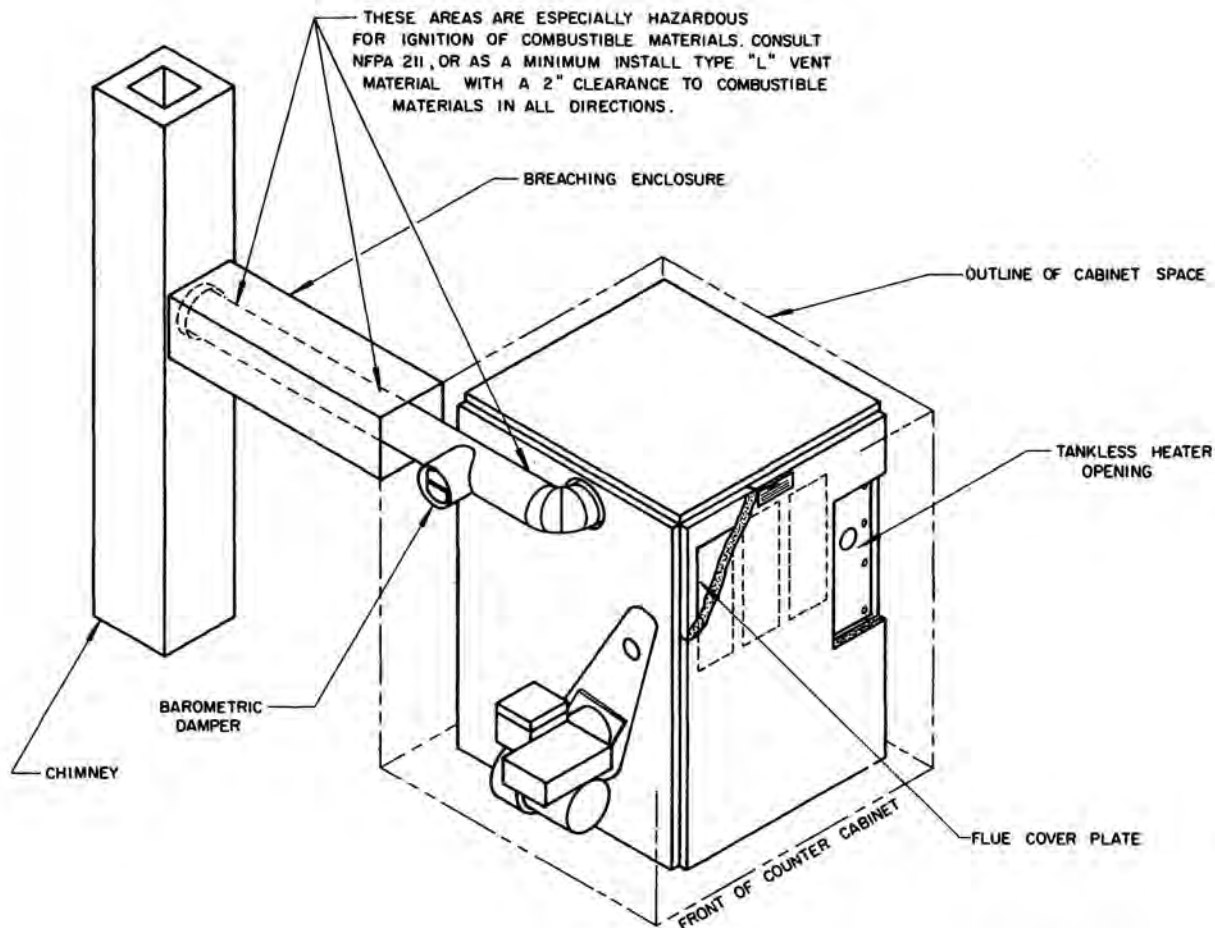

Figure 9: Installation of FO in a Confined Space with Remote Chimney

NOTE:

1. Type L Vent Material generally means stainless steel inner liner and stainless steel outer covering and separated with 1" thick special high temperature insulation - factory assembled and rated.
2. In a confined space, provide ventilation air to the burner and size such ventilation air openings to provide not less than 28 square inches free area per gallon of fuel input to the burner.
3. Keep right side of boiler accessible for flue cleanout and tankless coil maintenance.
4. Boiler is heavily insulated and is suitable for 1" clearance from jacket surface to combustibles.
5. Boiler is of wet base design and suitable for installation on combustible floors.
6. The original installation may have been under poor or outdated building codes. Replacement boilers are subject to codes in effect at the time of replacement. Be sure to consult with local code officials before starting replacement.
7. Copies of NFPA 211 are available from National Fire Protection Association, Battery March Park, Quincy, MA 02269 or at your local fire code officers office.

G. INSTALL REMAINDER OF EQUIPMENT in accordance with Figure 15.

1. INSTALL DRAFT REGULATOR following instructions furnished with Regulator. See Figure 10.
2. Consider the chimney overall. Chimneys that have a high heat loss may become less suitable as the heat loss of the home goes down and the efficiency of the boiler installed goes up. Most homes have a chimney appropriate for the fuel and the era in which the home was built. That may have been a coal fired or an inefficient oil fired boiler built into a home without insulation or storm windows. With increasing fuel prices that home probably has been insulated and fitted with storm windows so that the heat loss of the home has been reduced. This requires less fuel to be burned and sends less heat up the chimney.

A new boiler probably has a higher efficiency than the boiler being replaced. That probably means that the stack temperature from the new boiler will be lower than that from the old boiler and with less room air being drawn up the chimney to dilute the stack gases. The combination of a large uninsulated chimney, reduced firing rate, reduced firing time, lower stack temperature and less dilution air can, in some cases, contribute to the condensing of small amounts of water vapor in the chimney. Such condensation, when it occurs, can cause chimney deterioration. In extreme cases, condensed water may be visible on the outside of the breeching or chimney. In those extreme cases, the chimney may have to be lined to insulate the chimney and thus prevent the condensation. The addition of dilution air into the chimney may assist in drying the chimney interior surfaces.

3. For the same reasons as in (b) above, heat extractors mounted into the breeching are not recommended.

H. CONNECT TANKLESS HEATER PIPING AS SHOWN IN Figure 11. See Table 2 for Tankless Heater Ratings.

THE FOLLOWING GUIDELINES SHOULD BE FOLLOWED WHEN PIPING THE TANKLESS HEATER:

1. FLOW REGULATION - If low through the heater is greater than its rating, the supply of adequate hot water may not be able to keep up with the demand. For this reason a flow regulator matching the heater rating should be installed in the cold water line to the heater. The flow regulator should preferably be located below the inlet to the heater and a minimum of 3' away from the inlet so that the regulator is not subjected to excess temperatures that may occur during "off" periods when it is possible for heat to be conducted back through the supply line. The flow regulator also limits the flow of supply water regardless of inlet pressure variations in the range of 20 to 125 psi.

WARNING

Install automatic mixing valve at tankless heater outlet to avoid risk of burns or scalding due to excessively hot water at fixtures. Adjust and maintain the mixing valve in accordance with the manufacturer's instructions.

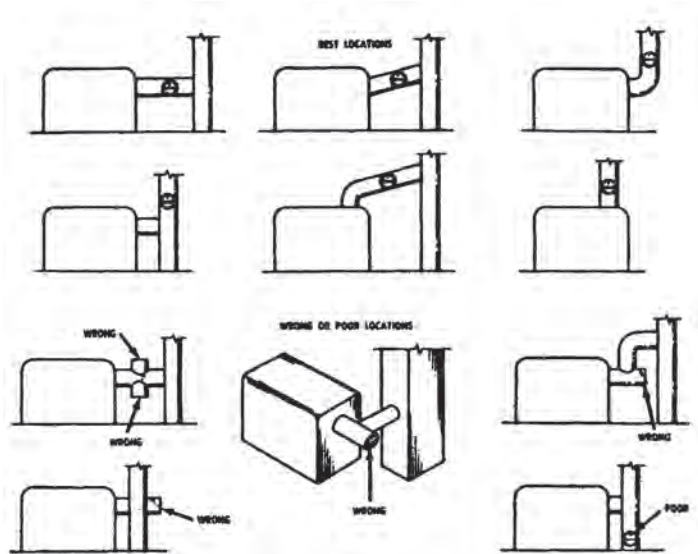

Figure 10: Proper and Improper Locations of Draft Regulator

Table 2: Tankless Heater Data

Boiler Model	Heater No.	Heater Rating (GPM)	Pressure Drop Thru Heater (PSI)
V13AT	V1-2	3¼	5.6
V14AT	V1-1	3½	4.4
	V1-2	4	8.0

Tankless heater ratings in the V1A oil boilers are based on intermittent draw, temperature rise of 100°F (40-140°F) and boiler water temperature of 200°F.

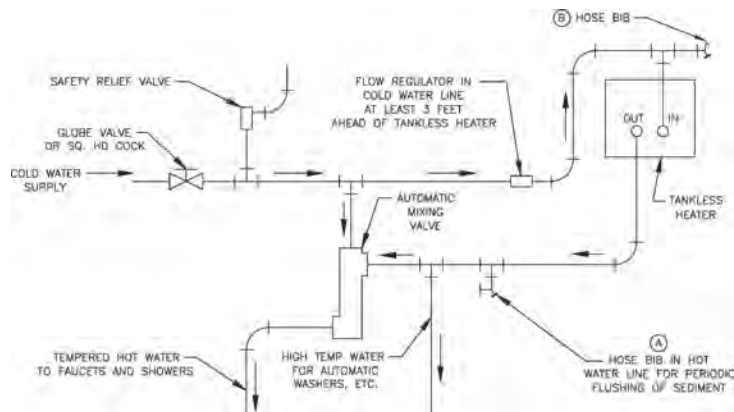

Figure 11: Schematic Tankless Heater Piping

2. **TEMPERING OF HOT WATER** - Installation of an automatic mixing valve will lengthen the delivery of the available hot water by mixing some cold water with the hot. This prevents excessive and possibly scalding hot water at the fixtures. In addition, savings of hot water will be achieved since the user will not waste as much hot water while seeking water temperature to his liking. Higher temperature hot water required by dishwashers and automatic washers is possible by piping the hot water from the heater prior to entering the mixing valve. The mixing valve should be "trapped" by installing it below the cold water inlet to heater to prevent lime formation in the valve.

I. CONNECT OIL LINES - Do not use compression fittings. Use only flare fitting. Note that the pump supplied on the V1 RO/FO is TWO-STAGE and is set up for TWO-PIPE operation, see Figure 12. Refer to Table 3 for recommended maximum lengths to be used.

Table 3: Two-Pipe Systems - Two Stage Pump

Lift "L" (feet)	Length of Tubing* (feet)	
	Two-Stage Units	
	3/8" OD	1/2" OD
0	68	100
2	63	100
4	58	100
6	53	100
8	48	100
10	42	100
12	37	100
14	32	100
16	27	100
18	22	88

* Line lengths include both vertical and horizontal lengths.

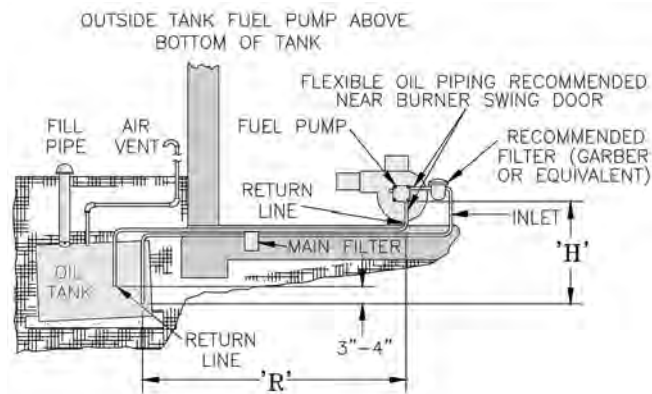
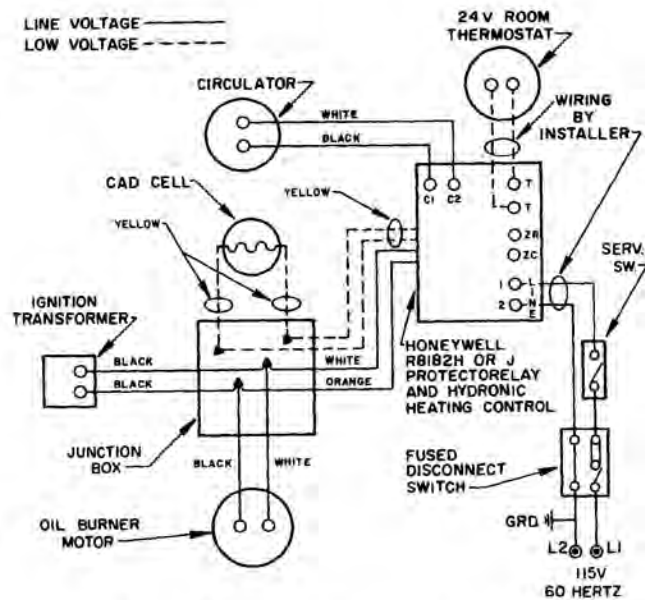

Figure 12: Two-Pipe Installation

J. INSTALL ELECTRIC WIRING in accordance with National Electric Code and local regulations. A separate ELECTRICAL CIRCUIT should be run from meter with a Fused Disconnect Switch in the Circuit. Wiring should conform to Figure 13.



0.5 Amp Thermostat Heat Anticipator Setting

Figure 13: Wiring Diagram

SEQUENCE OF OPERATION

A call for heat by the thermostat energizes the R8182 control to turn on the burner. If burner ignites within approximately 45 seconds, cad cell sees flame and burner continues to operate until call for heat is satisfied.

On the R8182J model control the circulator is also energized on call for heat. The Burner and Circulator will operate until the Thermostat is satisfied. Interruption of the circuit by the High Limit Switch in the control will stop the burner only.

On the R8182H model control the circulator operates only if boiler water temperature is up to the setting of the low limit. If boiler water temperature is below the low limit setting, the burner will operate but circulator will not in order to give preference to the domestic hot water demand. On call for heat by the thermostat the burner will operate until the thermostat is satisfied or the setting of the high limit is reached. If the thermostat is not satisfied when the high limit is reached, the circulator will continue to operate and the burner will remain off until the high limit circuit is closed by a drop in boiler water temperature.

SECTION III: OPERATING AND SERVICE INSTRUCTIONS

A. FILL ENTIRE HEATING SYSTEM WITH WATER

and vent air from system. Use the following procedure on a Series Loop system installed as per Figure 4:

- (1) Close all but one zone valve.
- (2) Open drain valve on boiler.
- (3) Open fill valve.
- (4) Close purge valve.
- (5) Open relief valve on boiler.
- (6) Allow water to run out of drain valve until zone has been purged of air and filled with water.
- (7) Open zone valve to the second zone to be purged, then close the first. Repeat this step until all zones have been purged but always have one zone open. At completion open all zone valves.
- (8) Close drain valve.
- (9) When water discharges from relief valve, release the lever on the top of the relief valve, allowing it to close.
- (10) Continue filling the system until the pressure gauge reads 12 psi. Close fill valve.

NOTE: If make-up water line is equipped with pressure reducing valve, system will automatically fill to 12 psi. Leave globe valve open.

- (11) Open purge valve.

B. CHECK CONTROLS, WIRING AND BURNER to be sure that all connections are tight and burner is rigid, that all electrical connections have been completed and fuses installed, and that oil tank is filled and oil lines have been tested.

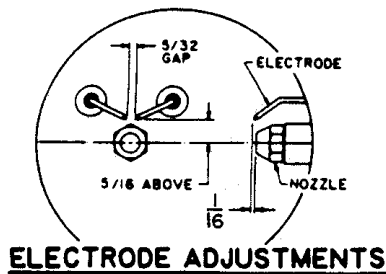

C. LUBRICATE MOTOR on oil burner. Circulator Motor and bearings were pre-oiled at Factory. Adhere to instructions included with this equipment.

D. SET CONTROLS with burner service switch turned "OFF".

1. SET ROOM THERMOSTAT about 10° above room temperature.
2. PRESS RED RESET LEVER on R8182 control and release.
3. ON UNITS WITHOUT TANKLESS HEATER, set high limit dial (R8182) at 210°. This temperature may be varied to suit requirements of installation.
4. ON UNITS WITH TANKLESS HEATER, set operating control dial (R8182) at 190°F and high limit dial at 210°. Operating Control must be minimum of 20° below High Limit Setting. Set Differential at 25°.

E. REMOVE GUN ASSEMBLY

V1 RO/FO Boilers are equipped with Beckett AFG burners. Items to be checked are nozzle size, gun setting, and positioning of electrodes. This information is shown in Figure 14 for the Beckett AFG burners. Reinstall gun assembly.

F. ADJUST OIL BURNER BEFORE STARTING

1. SET BURNER AIR BAND, see Table 4.
2. OPEN ALL OIL LINE VALVES.
3. REMOVE GAUGE PORT PLUG or attach plastic hose to vent fitting and provide a pan to catch the oil.
- d. OPEN FLAME OBSERVATION DOOR on front of Boiler.

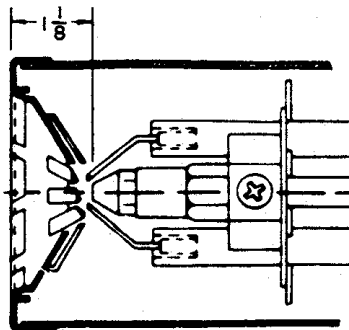

Figure 14: Beckett AFG Gun Setting and Electrode Positioning

Table 4: Beckett AFG Burner

Boiler Model	Firing Rate	Air Shutter Setting	Air Band Setting	Head	Static Disc	Nozzle Data			
						GPH	Angle	Type	Mfg.
V13 RO/FO*	0.75	7	0	F3	3½"	0.75	90°	A	Delavan
V14 RO/FO*	1.05	10	2			1.00	80°		

* Low Firing Rate Baffle Is Used on V13 RO/FO

Settings are approximate and must be verified by smoke and CO2 measurement.

Readjust where necessary.

CHIMNEY NOT LESS THAN 6" X 6" X 15 FT. ON ALL BOILER SIZES EXCEPT V-18. 8" X 12" X 15 FT. ON THIS BOILER. CONSTRUCTION SHOULD BE ADEQUATE TO FURNISH SUFFICIENT DRAFT FOR GOOD COMBUSTION.

INSTALL FUEL OIL TANK AND OIL LINES IN ACCORDANCE WITH THE STANDARDS OF THE NATIONAL BOARD OF FIRE UNDERWRITERS FOR THE CLASS. LOCAL AUTHORITIES HAVING JURISDICTION SHOULD BE CONSULTED.

INSTALL FUEL OIL TANK AND OIL LINES IN ACCORDANCE WITH THE STANDARDS OF THE NATIONAL BOARD OF FIRE UNDERWRITERS FOR THE CLASS. LOCAL AUTHORITIES HAVING JURISDICTION SHOULD BE CONSULTED.

ALTERNATE POSITION FOR DRAFT REGULATOR INSTALLED AS CLOSE TO BOILER AS POSSIBLE IN HORIZONTAL SECTION

SMOKEPIPE
6" DIAM. ON V-13 & V-14, 7" DIAM. ON V-15 & V-16, 8" DIAM. ON V-17 & V-18. SLOPES UP TOWARD CHIMNEY WITH A MINIMUM NUMBER OF ELBOWS. END OF SMOKEPIPE SHOULD BE FLUSH WITH INSIDE OF CHIMNEY. SEAL TIGHT BETWEEN SMOKEPIPE AND CHIMNEY. PROTECT COMBUSTIBLE WALLS AND CEILING CLOSE TO SMOKEPIPE WITH FURNACE CEMENT OR OTHER FIREPROOF INSULATION.

BASE OF CHIMNEY MAY BE CURVED FOR SMOOTHER COMBUSTION UNLESS LOCAL ORDINANCE REQUIRES CLEANOUT AT BASE

CONNECT TO LOWER TAPPING TO REAR OF BOILER OR AS ILLUSTRATED IN FIG. 5

INSTRUCTION ENVELOPE TO BE FASTENED TO WALL CONVENIENT TO BOILER.

AUXILIARY FILTER IN SUCTION OIL LINE. THE USE OF TWO FILTERS IN SUCTION LINE IS RECOMMENDED, ONE AT OUTLET OF TANK AND ONE AT SUCTION SIDE OF FUEL UNIT.

SHUT-OFF VALVE IN BOTH SUCTION AND RETURN LINES AT BURNER FOR CONVENIENCE IN SERVICING BURNER.

FLEXIBLE LOOP IN ALL OIL LINES AT OIL BURNER.

FUEL UNIT CONNECTIONS AND BY-PASS SHOULD BE MADE ACCORDING TO INSTRUCTIONS ATTACHED TO FUEL UNIT. IF TANK IS MORE THAN 20 FT. FROM BURNER A 2-STAGE FUEL UNIT SHOULD BE INSTALLED IN PLACE OF THE SINGLE-STAGE FUEL UNIT SUPPLIED AS STANDARD EQUIPMENT WITH BOILER. THE DIRECTION OF ROTATION MUST BE THE SAME.

FLOW CONTROL VALVE WHEN BUILT-IN HEATER IS USED

AIR CUSHION TANK LOCATED ABOVE SUPPLY MAIN. INSTALL EXPANSION TANK DRAIN VALVE IN TANK AND SHUT-OFF VALVE IN LINE TO FACILITATE DRAINING.

VENTILATION ADEQUATE SUPPLY AIR FOR PROPER COMBUSTION

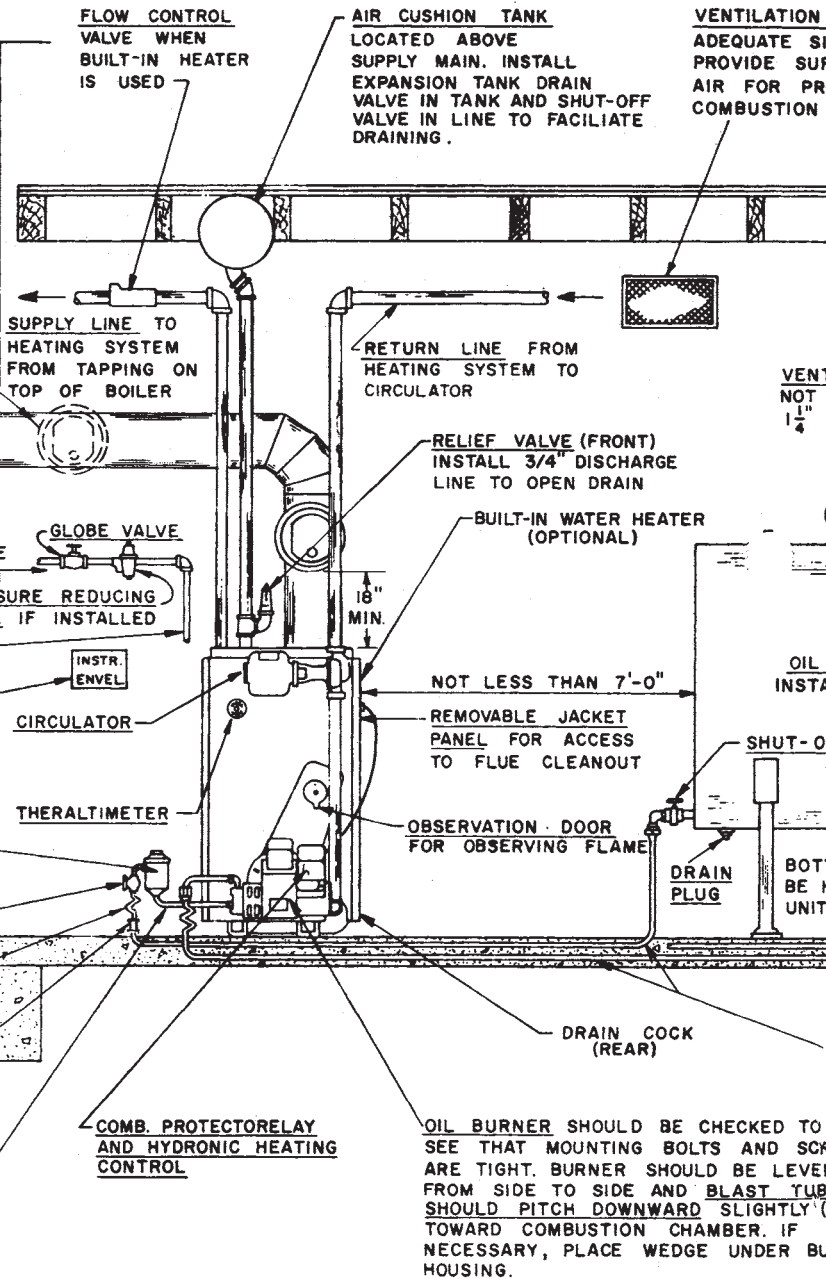

Figure 15: Installation Recommendations for V1A Series Oil Heating Units

HERE. PLACE ON AN INSIDE WALL ABOUT
 THE FLOOR. NEVER INSTALL THERMOSTAT
 ON WALL OR WHERE IT WILL BE INFLUENCED
 BY HOT OR COLD WATER PIPES, LIGHTING
 OR DIRECT RAYS OF THE SUN OR NEAR A
 LARGE FURNITURE AWAY FROM
 THERE WILL BE FREE MOVEMENT OF
 THE CONTROL.

INSTALL ELECTRIC WIRING FROM ELECTRIC SERVICE AND
 FROM THERMOSTAT TO COMBINATION PROTECTORELAY AND
 HYDRONIC HEATING CONTROL ON BOILER AS SHOWN BY
 WIRING DIAGRAM IN MANUAL. INSTALL WIRING IN ACCORD-
 ANCE WITH NATIONAL ELECTRIC CODE AND LOCAL REGU-
 LATIONS. A FUSED DISCONNECT SWITCH SHOULD BE USED
 IN A SEPARATE CIRCUIT FROM METER.

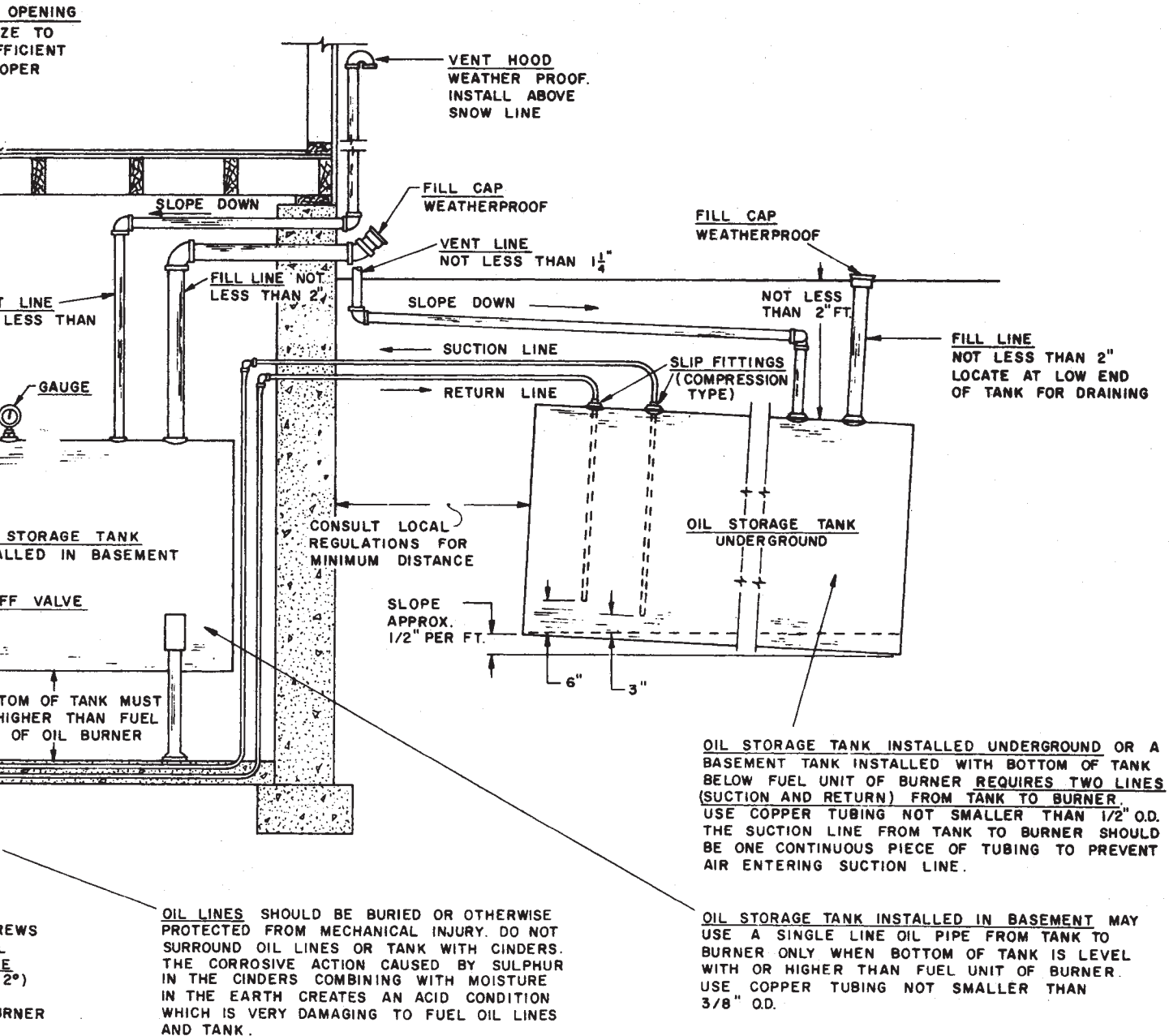

Figure 15: Installation Recommendations for V1A Series Oil Heating Units

G. START OIL BURNER

1. TURN "ON" BURNER service switch and allow burner to run until oil flows from gauge port or vent in a solid stream without air bubbles.
2. TURN "OFF" BURNER and install pressure gauge at gauge port on burner.
3. START BURNER AGAIN. Flame should start at this point.

H. ADJUST OIL PRESSURE

1. Locate oil pressure adjusting screw and turn screw for 100 lbs. pressure.
2. DO NOT REMOVE PRESSURE GAUGE until later.

I. OTHER ADJUSTMENTS

1. ADJUST THE AIR SHUTTER/AIR BAND

The Air Shutter and /or Air Band is adjusted by loosening the locking screw and rotating by hand. The pointer on the Air Shutter and the stamped mark on the Air Band should be adjusted against the scale embossed on the side of the burner housing. Refer to **Table 4** for preliminary settings. Always tighten locking screws.

2. ADJUST THE COMBUSTION HEAD

Beckett Burners have a fixed head/gun setting which was set at their factory and should not be re-adjusted unless incorrect. To check combustion head location refer to Figure 14.

3. READJUST AIR BANDS on burner for a light orange colored flame while the draft over the fire is $-.02"$. Use a smoke tester and adjust air for minimum smoke (not to exceed #1) with a minimum of excess air. Make final check using Orsat to determine CO^2 of $12\frac{1}{2}\%$ with draft of $-.02"$ over the fire.
4. TURN "OFF" BURNER and remove pressure gauge. Install gauge port plug or vent fitting and tighten. Start burner again.

J. TEST CONTROLS

WARNING

Before installation of the boiler is considered complete the operation of the boiler controls should be checked, particularly the primary control and the high limit control.

1. Check Thermostat operation. Raise and lower thermostat setting as required to start and stop burner.
2. VERIFY PRIMARY CONTROL SAFETY FEATURES using procedures outlined in instructions furnished with control (see back of control cover) or instructions listed below:
3. CHECKOUT PROCEDURE

CAUTION

FOR HEATING SERVICEMAN ONLY

- a. Check wiring connections. Close line switch. Check power at control.

PRIMARY RELAY TEST

- b. Disconnect cad cell leads (F-F). Reset safety switch.
- c. Set controller to call for heat. Burner should start.
- d. Jumper F-F terminals, within 15 to 30 seconds. Burner should run.
- e. Remove F-F jumper. Burner shuts down in approximately 15 to 60 seconds.
- f. If burner operates as described, relay is good. If not, install new relay.

CAD CELL TEST

- g. Open line switch. Clean cell face and see that cell is securely in socket. Reconnect leads. Reset safety switch.
 - h. Close line switch. If burner starts and runs beyond safety switch cut-out time, cell is good. If not, install new cell.
4. Check High Limit Control - Jumper Thermostat Terminals. Allow burner to operate until shut-down by limit. REMOVE JUMPER.
 5. Check Operating Control on boilers equipped with tankless heaters. With burner off, draw hot water until burner starts, then turn off hot water and check burner shut-down.

IF CONTROL DOES NOT MEET REQUIREMENTS OUTLINED IN PARAGRAPH (J), REPLACE CONTROL AND REPEAT CHECK-OUT PROCEDURES.

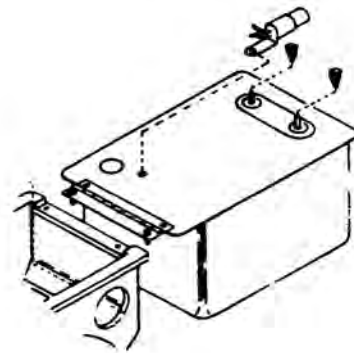

Figure 16: Cad Cell Location

6. CAD CELL LOCATION AND SERVICE

The burner is supplied with a cadmium sulfide flame detector mounted at the factory, mounted on the bottom of the transformer. See Figure 16. To service cad cell or to replace the plug in portion, swing open the transformer. After service is complete be sure to fasten down the transformer.

K. CHECK FOR CLEAN CUT OFF OF BURNER

1. AIR IN THE OIL LINE between fuel unit and nozzle will compress when burner is on and will expand when burner stops, causing oil to squirt from nozzle at low pre assure as burner slows down and causing nozzle to drip after burner stops. Usually cycling the burner operation about 5 to 10 times will rid oil line of this air.
2. IF NOZZLE CONTINUES TO DRIP, repeat step (K.1.). If this does not stop the dripping, remove cut-off valve and seat, and wipe both with a clean cloth until clean, then replace and re-adjust oil pressure.

L. HINTS ON COMBUSTION

1. NOZZLES - Although the nozzle is a relatively inexpensive device, its function is critical to the successful operation of the oil burner. The selection of the nozzle supplied with the V1 RO/FO boiler is the result of extensive testing to obtain the best flame shape and efficient combustion. Other brands of the same spray angle and spray pattern may be used but may not perform at the expected levels of CO and smoke. Nozzles are delicate and should be protected from dirt and abuse. Nozzles are mass-produced and can vary from sample to sample. For all of those reasons a spare nozzle is a desirable item for a serviceman to have.
2. FUEL LEAKS - Any fuel leak between the pump and the nozzle will be detrimental to good combustion results. Look for wet surfaces in the air tube, under the transformer, and around the air inlet. Any such leaks should be repaired as they may cause erratic burning of the fuel and in the extreme case may become a fire hazard.
3. AIR LEAKS - Any air leaks in the fuel line will cause an unstable flame and may cause delayed ignition noises. Use only flare fittings in the fuel lines.
4. GASKET LEAKS - If 12% CO² with a #1 smoke cannot be obtained in the breeching, look for air leaks around the burner mounting gasket, observation door and canopy gasket. Such air leaks will cause a lower CO² reading in the breeching. The smaller the firing rate the greater effect an air leak can have on CO² readings.
5. DIRT - A fuel filter is a good investment. Accidental accumulation of dirt in the fuel system can clog the nozzle or nozzle strainer and produce a poor spray pattern from the nozzle. The smaller the firing rate, the smaller the slots become in the nozzle and the more prone to plugging it becomes with the same amount of dirt.
6. WATER - Water in the fuel in large amounts will stall the fuel pump. Water in the fuel in smaller

amounts will cause excessive wear on the pump, but more importantly water doesn't burn. It chills the flame and causes smoke and unburned fuel to pass out of the combustion chamber and clog the flueways of the boiler.

7. COLD OIL - If the oil temperature approaching the fuel pump is 40°F or lower poor combustion or delayed ignition may result. Cold oil is harder to atomize at the nozzle. Thus, the spray droplets get larger and the flame shape gets longer. An outside fuel tank that is above grade or has fuel lines in a shallow bury is a good candidate for cold oil. The best solution is to bury the tank and lines deep enough to keep the oil above 40°F. If that is not possible, the conditions can be helped by using a smaller nozzle and higher pump pressure as shown below:

Boiler Model	Delavan Nozzle	Pump Pressure, PSI
V13RO/FO	0.65 - 90° A	140
V14RO/FO	0.90 - 80° A	140

For the benefit of the next serviceman, place a tag on the burner showing the pump pressure and nozzle size that was installed.

8. FLAME SHAPE - Looking into the combustion chamber through the observation door, the flame should appear straight with no sparklers rolling up toward the crown of the chamber. If the flame drags to the right or left, sends sparklers upward, or makes wet spots on the target wall, the nozzle should be replaced. If the condition persists look for fuel leaks, air leaks, water or dirt in the fuel or cold oil conditions as described above.
9. START-UP NOISE - Late ignition is the cause of start-up noises. If it occurs recheck for electrode settings, flame shape, air or water in the fuel lines.
10. SHUT DOWN NOISE - If the flame runs out of air before it runs out of fuel, an after burn with noises may occur. That may be the result of a faulty cut-off valve in the fuel pump or it may be air trapped in the nozzle line. It may take several firing cycles for that air to be fully vented through the nozzle. Water in the fuel or poor flame shape can also cause shut down noises.

IMPORTANT

A very good test for isolating fuel side problems is to disconnect the fuel system and with a 24" length of tubing, fire out of an auxiliary five gallon pail of clean, fresh, warm #2 oil from another source. If the burner runs successfully when drawing out of the auxiliary pail then the problem is isolated to the fuel or fuel lines being used on the jobsite.

SECTION IV: CLEANING OF BOILER

A. TO CLEAN FLUEWAYS

1. Free Control Capillary Tubing, see Figure 1. Remove screws from plastic clips securing capillary to jacket. Loosen screw at control well, remove sensing element and place where it will not get damaged.
2. Remove Right Side Jacket Panel by removing screws holding panel to other jacket panels.
3. Loosen nut securing Flue Cleanout Plates and remove plates exercising caution so that Asbestos Rope seals remain in place on plates.
4. Using 1¼" diameter wire or fibre bristle brush (30" handle) and vacuum, clean flueways. Use horizontal and diagonal strokes for best results. **DO NOT ALLOW BRUSH TO STRIKE TARGET WALL AT BOTTOM OF REAR SECTION.**

B. TO CLEAN FIREBOX (CROWN AND INSIDE OF WATERLEGS)

1. Disconnect oil line(s) and remove Burner and Burner Mounting Plate, see Figure 1.
2. Using wire or fibre bristle brush and vacuum, clean crown of boiler and inside of water legs. **DO NOT ALLOW BRUSH TO STRIKE TARGET WALL AT BOTTOM OF REAR SECTION.**

C. TO CLEAN TOP OF BOILER SECTION

1. Remove smokepipe from flue collar of canopy, see Figure 1.

2. Using wire or fibre bristle brush and vacuum, clean top of boiler through flue collar of canopy.

D. REASSEMBLY OF PARTS

1. Reinstall smokepipe on canopy and secure to collar with SMS.
2. Bolt burner mounting plate to front section using silastic or furnace cement to seal plate to section.
3. Bolt burner to burner mounting plate and connect oil line(s).
4. Reinstall flue plates (arrow on plates pointing up) making sure gasket on each plate is in place and forms gas tight seal.
5. Reinstall Right Side Jacket Panel and secure with SMS.
6. Place sensing element of control into well and bottom. Tighten screw. Secure capillary to jacket with plastic clips.

WARNING

The boiler must be connected to an approved chimney in good condition. Serious property damage could result if the boiler is connected to a dirty or inadequate chimney. The interior of the chimney flue must be inspected and cleaned before the start of the heating season for any obstructions. A clean and unobstructed chimney flue is necessary to allow noxious fumes that could cause injury or loss of life to vent safely and will contribute toward maintaining the boiler's efficiency.

TANKLESS HEATER PERFORMANCE

Tankless heater ratings in the V1A oil boilers are based on intermittent draw, temperature rise of 100°F (40-140°F) and boiler water temperature of 200°F. Some of the items effecting the coil performance are as follows:

A. FLOW REGULATION - If flow through the heater is greater than its rating, the supply of adequate hot water may not be able to keep up with the demand. For this reason a FLOW REGULATOR matching the heater rating (see Table below) should be installed in the cold water line to the heater. The flow regulator should preferably be located below the inlet to the heater and a minimum of 3 feet away from the inlet so that the regulator is not subjected to excess temperatures that may occur during "off" periods when it is possible for heat to be conducted back through the supply line. The flow regulator also limits the flow of supply water regardless of inlet press variations in the range of 20 to 125 psi.

Boiler Model	Heater No.	Heater Rating (GPM)	Pressure Drop thru Heater (PSI)
V13AT	V1-2	3¼	5.6
V14AT	V1-1	3½	4.4
	V1-2	4	8.0

B. TEMPERING OF HOT WATER - Installation of a tempering or mixing valve will lengthen the delivery of the available hot water by mixing some cold water with the hot. This prevents excessive and possibly scalding hot water at the fixtures. In addition, savings of hot water will be achieved since the user will not waste as much hot water while seeking water temperatures to his liking. Higher temperature hot water required by dishwashers and automatic washers is possible by piping the hot water from the heater prior to entering the mixing valve. The mixing valve should be "trapped" by installing it below the cold water inlet to heater to prevent lime formation in the valve.

C. FLUSHING OF HEATER - All water contains some sediment which settles on the inside of the coil. Consequently, the heater should be periodically backwashed. This is accomplished by installing hose bibs as illustrated in Figure 3 and allowing water at city pressure to run into hose bib A, through the heater, and out hose bib B until the discharge is clear. The tees in which the hose bibs are located should be the same size as heater connections to minimize pressure drop.

D. HARD WATER - This applicable to some city water and particularly to well water. This should not be a deterrent but precautions are necessary. A water analysis is necessary and an appropriate water softener installed. This is not only beneficial to the heater but to piping and fixtures plus the many other benefits derived from soft water.

AQUASTAT SWITCHING ACTION WITHIN R8182H AND R8182J CONTROLS

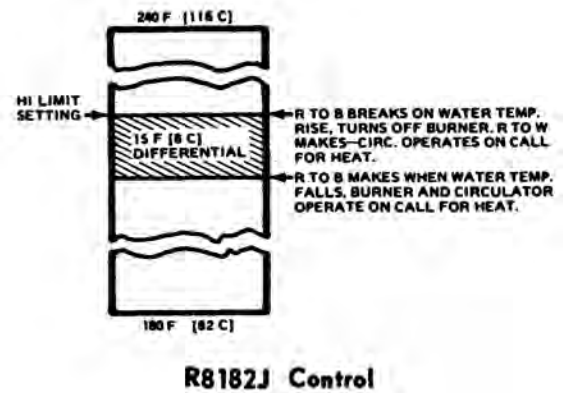
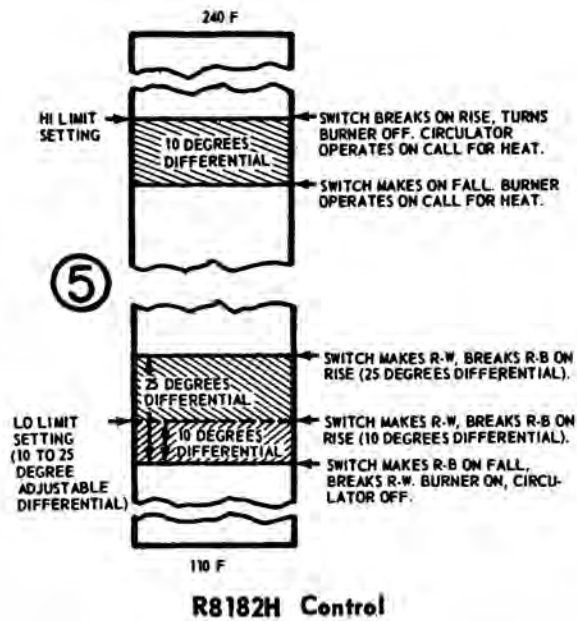

The above diagrams show switching actions within the respective control. There are one or three settings:

1. high limit (R8182H and R8182J)
2. low limit (R8182H only)
3. adjustable differential (R8182H only)

R8182H and R8182J controls - High Limit Operation
 - The high limit opens and turns off the burner when the water temperature reaches the set point. The high limit automatically resets after the water temperature drops past the set point and through the 10°F differential (15°F differential - R8182J control).

Set the indicator at desired shutoff temperature.

R8182H control - Low Limit Operation - On a temperature rise, with the adjustable differential at the minimum setting of 10°F, the burner circuit (R-B) breaks and the circulator circuit (R-W) makes at the low limit set point. On a temperature drop of 10°F below the set point, the R-B circuit makes and the R-W circuit breaks.

At any differential setting greater than 10°F, the R-B make temperature and R-W break temperature will remain the same-control setting minus 10°F. The R-B break and R-W make temperature will be the set point temperature plus the difference between the differential setting and 10°F.

EXAMPLE: Set point of 140°F; differential set at 25°F. On a temperature rise, R-B will break and R-W will make at 155°F. On a temperature fall, R-B will make and R-W will break at 130°F.

Set low limit indicator at the minimum temperature recommended for domestic hot water supply. This setting *must* be at least 20°F below high limit setting to prevent one switch from locking out the other.

Set the differential the desired number of degrees. 25°F differential gives longest burner cycles.

SECTION V: REPAIR PARTS

All V1™ Series Boiler Repair Parts may be obtained through your local Burnham Wholesale distributor. Should you require assistance in locating a Burnham Distributor in your area, or have questions regarding the availability of Burnham products or repair parts, please contact Burnham Customer Service at (717) 481-8400 or Fax (717) 481-8408.

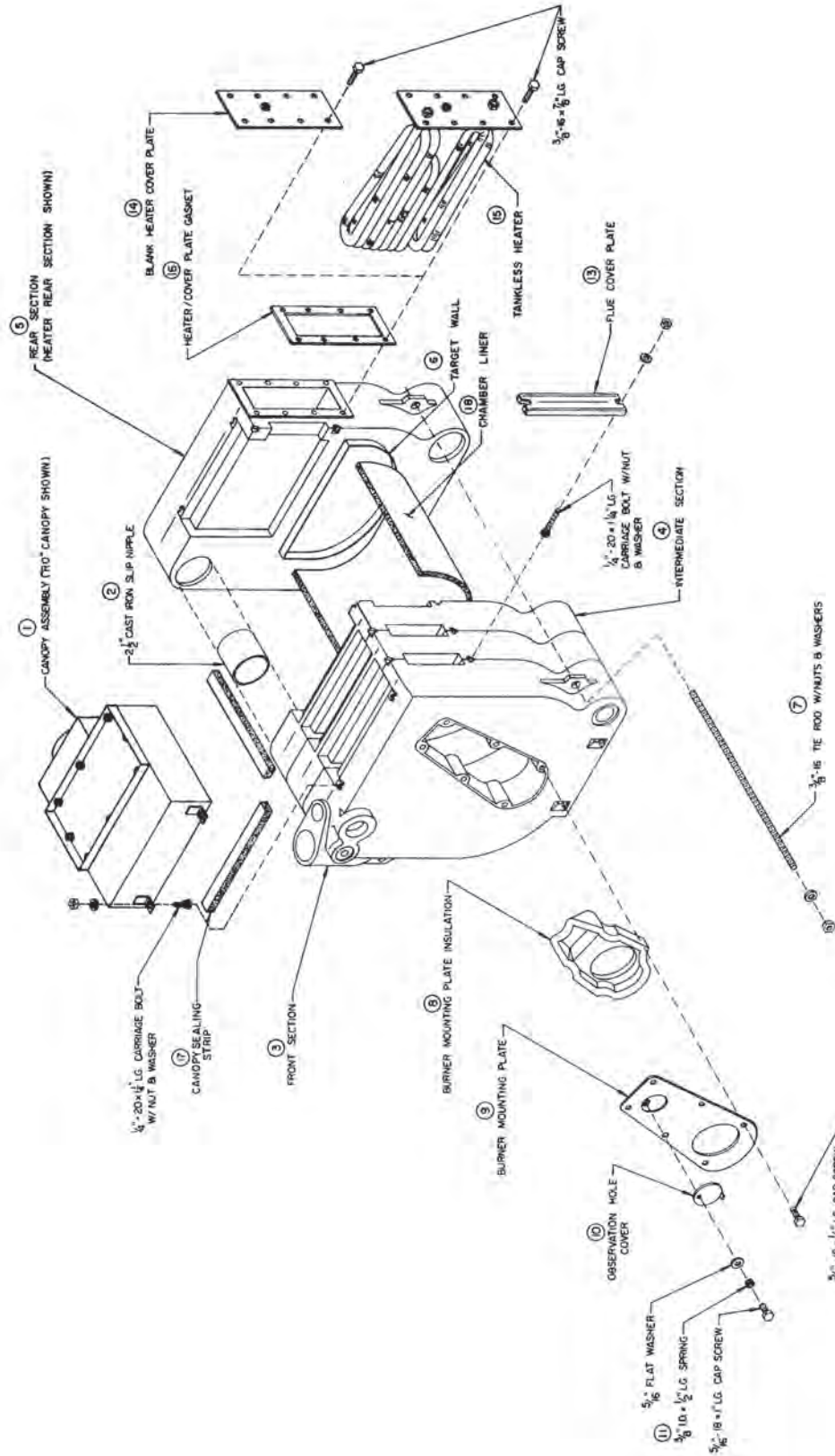

Key No.	Description	RO/FO Boiler Size/Quantity		Part Number
		V13	V14	
1	Canopy, Rear Outlet	1	---	61122033
	Front Outlet	1	---	61122032
	Rear Outlet	---	1	61122043
	Front Outlet	---	1	61122042
Section Assembly Complete with Key Nos. 2 thru 9		1	---	6172203
		---	1	6172204
2	2-1/2" Cast Iron Nipple	4	6	7066001
3	Front Section	1	1	7172201
4	Intermediate Section	1	2	7172202
5	Heater Rear Section	1	1	7172203
	Non-Heater Rear Section	1	1	7172204
6	Flame Target Wall	1	1	8202211
7	Tie Rod Sets			
	Tie Rods, 3/8" - 16 x 12-1/2" Lg.	2	---	80861010
	Tie Rods, 3/8" - 16 x 17" Lg.	---	2	80861011
	Hex Nuts, 3/8" - 16	4	4	80860400
	Flat Washers, 3/8"	4	4	80860600
8	Burner Mounting Plate Insulation	1	1	8202210
9	Burner Mounting Plate	1	1	6022210
10	Observation Hole Cover	1	1	7026001
11	3/8" ID x 1/2" Spring	1	1	8026015
13	Flue Cover Plate Assembly	2	3	6112214
14	Blank Heater Cover Plate	1	1	7032201
15	Tankless Heaters, V1-1	---	1	8032201
	Tankless Heaters, V1-2	1	1	8032202
16	Gasket-Tankless Heater or Cover Plate	1	1	8032203
17	Canopy Sealing Strips, 1/2 x 1" x 8'	1	1	6206003
18	Combustion Chamber Liner, 24" x 5"	1	---	82022033
	Combustion Chamber Liner, 24" x 9"	---	1	82022043

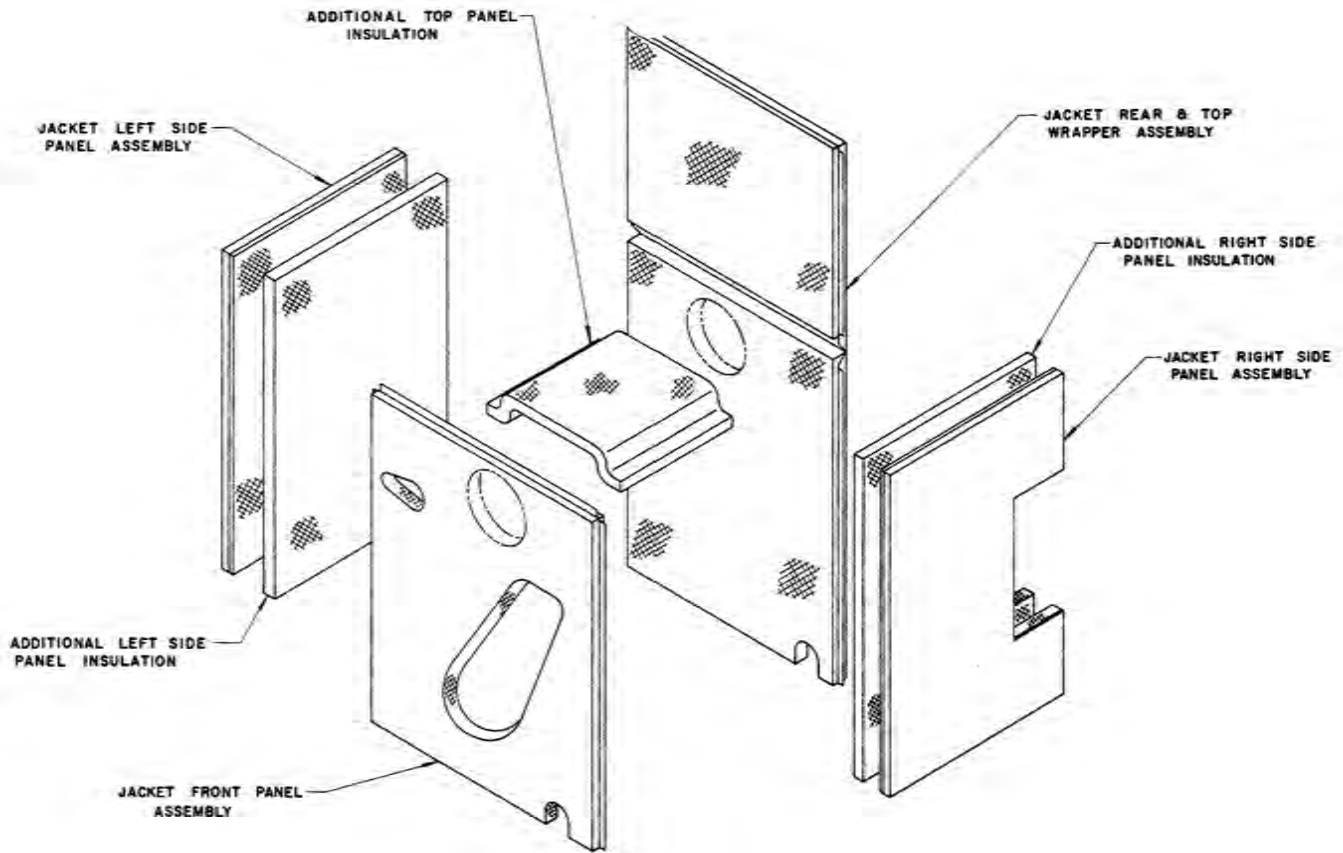

Description	RO/FO Boiler Size/Quantity		Part Number
	V13	V14	
FLUSH JACKET COMPONENTS			
Items 1 thru 5 include insulation as part of Assembly			
Jacket Left Side Panel Assembly	1	---	60422032
	---	1	60422042
Jacket Top & Rear Wrapper Assembly	1	---	60422034
	---	1	60422044
Jacket Right Side Panel Assembly	1	---	60422033
	---	1	60422043
Jacket Front Panel Assembly	1	1	6042212
Additional Boiler Top Insulation Piece	1	---	7202215
	---	1	7202216
Additional Right Side Panel Insulation Piece	1	---	72022033
	---	1	72022043
Additional Left Side Panel Insulation Piece	1	---	72022032
	---	1	72022042
Complete Flush Jacket Assembly	1	---	60422035
	---	1	60422045

④ DRAFT REGULATOR

⑤ INSTRUCTION PACKAGE

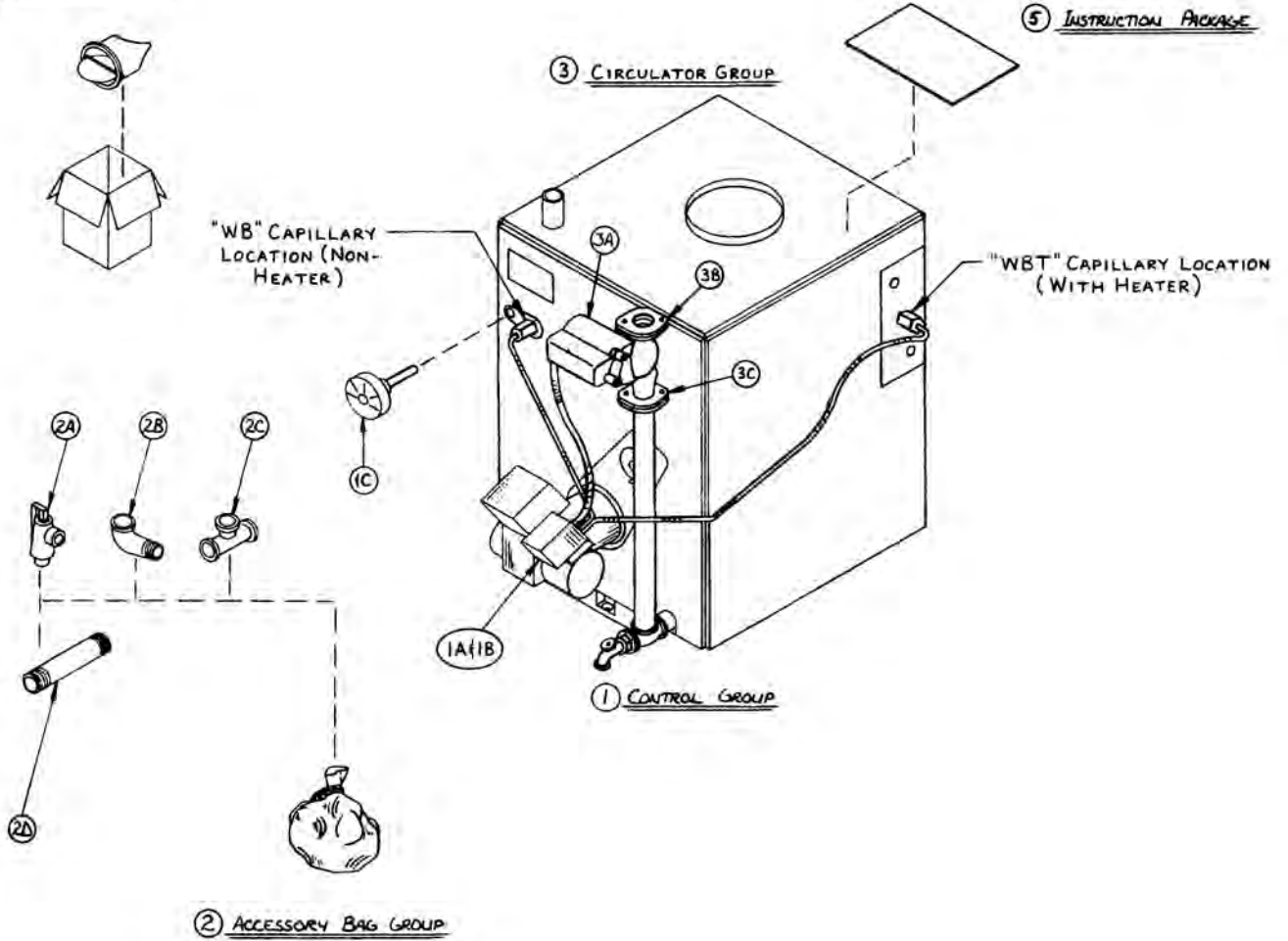

Key No.	Description	RO/FO Boiler Size/Quantity		Part Number
		V13	V14	
1	Control Group			
1A	R8182J1042 Comb. Control (Non Tankless Heater)	1	1	100544-01
	-OR-			
1B	R8182H1088 Comb. Control (Tankless Heater)	1	1	80160417
1C	Temperature/Pressure Gauge	1	1	8056169
2	Accessory Bag Group - Consisting of 2A thru 2D			
2A	30 PSI Relief Valve #10-407-05 Conbraco	1	1	81660363
2B	3/4" x 90° Street Elbow	1	1	806601501
2C	3/4" x 7" Nipple	1	1	806600195
3	Circulator Group			
3A	Taco 007-F Circulator	1	1	8056107
3B	1 1/4" Flange - Circulator	2	2	806602014
3C	Flange Gasket	2	2	806602006
4	DR-6 Draft Regulator Fits 6" Pipe	1	1	8116029
5	Instruction Package - Containing the following for all Boilers: Installation & Operating Instructions Form 52140 I=B=R Pamphlet Equipment Check List For 52039 Lifetime Warranty Mailer Form 57029			

BECKETT OIL BURNER PARTS LIST
 MODEL AFG - 60-Hz, 34-50 RPM

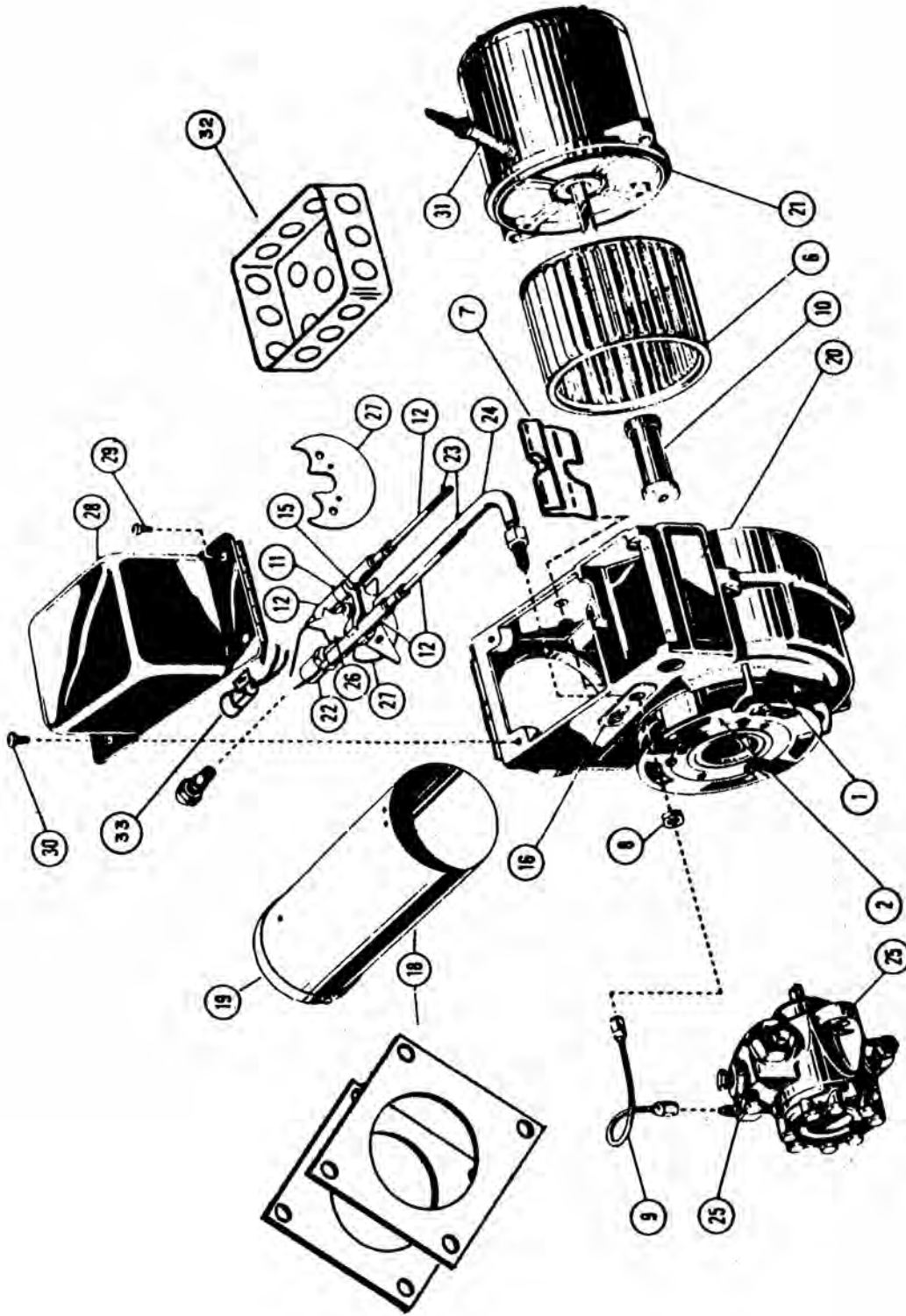

FOR REPLACEMENT OIL BURNER PARTS, CONTACT YOUR WHOLESALER OR THE BURNER MANUFACTURER:
 R. W. Beckett Co., 38251 Center Ridge Road, P.O. Box 1289, Elyria, Ohio 44036, (440) 327-1060

BECKETT PART NUMBERS FOR V1 RO/FO SERIES BOILERS - MODEL AFG BURNER

NOTE: When ordering parts always give the serial and model numbers shown on the boiler and burner. Also provide the name of the part(s) and part number as listed below.

Boiler Model	V13 RO/FO	V14 RO/FO
Air Tube Combination	AF44ZP	AF44ZP
Spec. No.	BCB=1101	BCB-1102
1) Air Band	3492	3492
Air Band Nut	4150	4150
Air Band Screw	4198	4198
2) Air Shutter	3709	3709
Air Shutter Screw	4198	4198
6) Blower	2999	2999
7) Low Firing Rate Baffle	3708P	3708P
8) Bulkhead Fitting Locknut	3666	3666
9) Connector Tube Assembly	5636	5636
10) Coupling	2454	2454
11) Electrode Clamp	149	149
Electrode Clamp Screw	4219	4219
12) Electrode Insulator Assembly	5780	5780
15) Spider Spacer Assembly	5503	5503
16) Escutcheon Plate	3493	3493
18) Flange and Air Tube Assembly	31419	31419
Welded Gasket	31420	31420
19) Head	360003	360003
Head Screws	4221	4221
Hole Plug	2139	2139
20) Housing Assembly w/Inlet Bell	5874	5874
21) Motor	2456	2456
22) Nozzle Adapter	213	213
23) Nozzle Line Electrode Assembly	NL44ZP	NL44ZP
25) Pump	2583	2583
27) Static Plate	3383P	3383P
28) Transformer	5878	5878
29) Transformer Hinge Screw	4217	4217
30) Transformer Holding Screw	4292	4292
31) Wire Guard	10251	10251
32) Junction Box	3741	3741
33) Flame Detector	7006	7006

Limited Warranty

For Residential Grade Water and Steam Boilers

Using Cast Iron, Carbon Steel, Cast Aluminum,
or Stainless Steel Heat Exchangers
and Parts/Accessories

Subject to the terms and conditions set forth below, U.S. Boiler Company, Inc. Lancaster, Pennsylvania hereby extends the following limited warranties to the original owner of a residential grade water or steam boiler or U.S. Boiler Company, Inc. supplied parts and/or accessories manufactured and shipped on or after July 1, 2008:

ONE YEAR LIMITED WARRANTY ON RESIDENTIAL GRADE BOILERS AND PARTS / ACCESSORIES SUPPLIED BY U.S. BOILER COMPANY, INC.

U.S. Boiler Company, Inc. warrants to the original owner that its residential grade water and steam boilers and parts/accessories comply at the time of manufacture with recognized hydronic industry standards and requirements then in effect and will be free of defects in material and workmanship under normal usage for a period of one year from the date of original installation. If any part of a residential grade boiler or any part or accessory provided by U.S. Boiler Company, Inc. is found to be defective in material or workmanship during this one year period, U.S. Boiler Company, Inc. will, at its option, repair or replace the defective part.

HEAT EXCHANGER WARRANTIES

U.S. Boiler Company, Inc. warrants to the original owner that the heat exchanger of its residential grade boilers will remain free from defects in material and workmanship under normal usage for time period specified in the chart below of the original owner at the original place of installation. If a claim is made under this warranty during the "No Charge" period from the date of original installation, U.S. Boiler Company, Inc. will, at its option, repair or replace the heat exchanger. If a claim is made under this warranty after the expiration of the "No Charge" period from the date of original installation, U.S. Boiler Company, Inc. will, at its option and upon payment of the pro-rated service charge set forth below, repair or replace the heat exchanger. The service charge applicable to a heat exchanger warranty claim is based upon the number of years the heat exchanger has been in service and will be determined as a percentage of the retail price of the heat exchanger model involved at the time the warranty claim is made as follows:

Years in Service	Service Charge as a % of Retail Price																											
	1-5	6	7	8	9	10	11	12	13	14	15	16	17	18	19	20	21	22	23	24	25+							
Cast Iron Water	No Charge					5	10	15	20	25	30	35	40	45	50	55	60	65	70	75								
Cast Iron Steam*	No Charge					100																						
Carbon Steel	No Charge					5	10	15	20	25	30	35	40	45	50	55	60	65	70	75								
Cast Aluminum	No Charge					30	40	50	60	70	100																	
Stainless Steel	No Charge					30	40	50	60	70	100																	

NOTE: If the heat exchanger involved is no longer available due to product obsolescence or redesign, the value used to establish the retail price will be the published price as shown in the Burnham® Products Repair Parts Pricing where the heat exchanger last appeared or the current retail price of the then nearest equivalent heat exchanger.

***Burnham® MegaSteam™ Waterside Corrosion Warranty:** U.S. Boiler Company, Inc. warrants the cast iron sections of the Burnham® MegaSteam™ boiler to resist Temperature Induced Chloride Activated Graphitic Corrosion for a period of five years from the date of original installation. In the event that any cast iron section of a Burnham® MegaSteam™ boiler fails due to this corrosion mechanism during this period, U.S. Boiler Company, Inc. will repair or replace, at its option, the cast iron section assembly.

LIFETIME NIPPLE LEAKAGE WARRANTY

U.S. Boiler Company, Inc. warrants the cast iron and steel nipples that join the cast iron boiler sections to be free of defects in material and workmanship for the lifetime of the original owner at the original place of installation. In the event that such nipples are found to be defective in material and workmanship during this period, U.S. Boiler Company, Inc. will repair or replace at its option, the cast iron section assembly.

ADDITIONAL TERMS AND CONDITIONS

1. Applicability: The limited warranties set forth above are extended only to the original owner at the original place of installation within the United States and Canada. These warranties are applicable only to boilers, parts, or accessories designated as residential grade by U.S. Boiler Company, Inc. and installed in a single or two-family residence and do not apply to commercial grade products.
2. Components Manufactured by Others: Upon expiration of the one year limited warranty on residential grade boilers, all boiler components manufactured by others but furnished by U.S. Boiler Company, Inc. (such as oil burner, circulator and controls) will be subject only to the manufacturer's warranty, if any.
3. Proper Installation: The warranties extended by U.S. Boiler Company, Inc. are conditioned upon the installation of the residential grade boiler, parts, and accessories in strict compliance with U.S. Boiler Company, Inc. installation instructions. U.S. Boiler Company, Inc. specifically disclaims liability of any kind caused by or relating to improper installation.
4. Proper Use and Maintenance: The warranties extended by U.S. Boiler Company, Inc. conditioned upon the use of the residential grade boiler, parts, and accessories for its intended purposes and its maintenance accordance with U.S. Boiler Company, Inc. recommendations and hydronics industry standards. For proper installation, use, and maintenance, see all applicable sections of the Installation and Operating, and Service Instructions Manual furnished with the unit.
5. This warranty does not cover the following:
 - a. Expenses for removal or reinstallation. The homeowner will be responsible for the cost of removing and reinstalling the alleged defective part or its replacement and all labor and material connected therewith, and transportation to and from U.S. Boiler Company, Inc.
 - b. Components that are part of the heating system but were not furnished by U.S. Boiler Company, Inc. as part of the residential boiler.
 - c. Improper burner adjustment, control settings, care or maintenance.

- d. This warranty cannot be considered as a guarantee of workmanship of an installer connected with the installation of the U.S. Boiler Company, Inc. boiler, or as imposing on U.S. Boiler Company, Inc. liability of any nature for unsatisfactory performance as a result of faulty workmanship in the installation, which liability is expressly disclaimed.
 - e. Boilers, parts, or accessories installed outside the 48 contiguous United States, the State of Alaska and Canada.
 - f. Damage to the boiler and/or property due to installation or operation of the boiler that is not in accordance with the boiler installation and operating instruction manual.
 - g. Any damage or failure of the boiler resulting from hard water or scale buildup in the heat exchanger.
 - h. Any damage caused by improper fuels, fuel additives or contaminated combustion air that may cause fireside corrosion and/or clogging of the burner or heat exchanger.
 - i. Any damage resulting from combustion air contaminated with particulate which cause clogging of the burner or combustion chamber including but not limited to sheetrock or plasterboard particles, dirt, and dust particulate.
 - j. Any damage, defects or malfunctions resulting from improper operation, maintenance, misuse, abuse, accident, negligence including but not limited to operation with insufficient water flow, improper water level, improper water chemistry, or damage from freezing.
 - k. Any damage caused by water side clogging due to dirty systems or corrosion products from the system.
 - l. Any damage resulting from natural disaster.
 - m. Damage or malfunction due to the lack of required maintenance outlined in the Installation and Operating Manual furnished with the unit.
6. Exclusive Remedy: U.S. Boiler Company, Inc. obligation for any breach of these warranties is limited to the repair or replacement of its parts in accordance with the terms and conditions of these warranties.
 7. Limitation of Damages: Under no circumstances shall U.S. Boiler Company, Inc. be liable for incidental, indirect, special or consequential damages of any kind whatsoever under these warranties, including, but not limited to, injury or damage to persons or property and damages for loss of use, inconvenience or loss of time. U.S. Boiler Company, Inc. liability under these warranties shall under no circumstances exceed the purchase price paid by the owner for the residential grade boiler involved. Some states do not allow the exclusion or limitation of incidental or consequential damages, so the above limitation or exclusion may not apply to you.
 8. Limitation of Warranties: These warranties set forth the entire obligation of U.S. Boiler Company, Inc. with respect to any defect in a residential grade boiler, parts, or accessories or U.S. Boiler Company, Inc. shall have no express obligations, responsibilities or liabilities of any kind whatsoever other than those set forth herein. These warranties are given in lieu of all other express warranties.

ALL APPLICABLE IMPLIED WARRANTIES, IF ANY, INCLUDING ANY WARRANTY OF MERCHANTABILITY OR FITNESS FOR A PARTICULAR PURPOSE ARE EXPRESSLY LIMITED IN DURATION TO A PERIOD OF ONE YEAR EXCEPT THAT IMPLIED WARRANTIES, IF ANY, APPLICABLE TO THE HEAT EXCHANGER IN A RESIDENTIAL GRADE BOILER SHALL EXTEND TO THE ORIGINAL OWNER FOR THE TIME SPECIFIED IN THE HEAT EXCHANGER SECTION SHOWN ABOVE AT THE ORIGINAL PLACE OF INSTALLATION. SOME STATES DO NOT ALLOW LIMITATION ON HOW LONG AN IMPLIED WARRANTY LASTS, SO THE ABOVE LIMITATION MAY NOT APPLY TO YOU.

PROCEDURE FOR OBTAINING WARRANTY SERVICE

In order to assure prompt warranty service, the owner is requested to complete and mail the Warranty Card provided with the product or register product online at www.usboiler.burnham.com within ten days after the installation of the boiler, although failure to comply with this request will not void the owner's rights under these warranties. Upon discovery of a condition believed to be related to a defect in material or workmanship covered by these warranties, the owner should notify the installer, who will in turn notify the distributor. If this action is not possible or does not produce a prompt response, the owner should write to U.S. Boiler Company, Inc., Attn: Customer Service, P.O. Box 3079, Lancaster, PA 17604, giving full particulars in support of the claim. The owner is required to make available for inspection by U.S. Boiler Company, Inc. or its representative the parts claimed to be defective and, if requested by U.S. Boiler Company, Inc. to ship these parts prepaid to U.S. Boiler Company, Inc. at the above address for inspection or repair. In addition, the owner agrees to make all reasonable efforts to settle any disagreement arising in connection with a claim before resorting to legal remedies in the courts.

THIS WARRANTY GIVES YOU SPECIFIC LEGAL RIGHTS AND YOU MAY ALSO HAVE OTHER RIGHTS WHICH VARY FROM STATE TO STATE.



U.S. Boiler Company, Inc., P.O. Box 3020, Lancaster, PA 17604