INSTALLATION INSTRUCTIONS

Full Flow Low Leakage Economizer with Exhaust for Building Applications (To Be Used with Field-Installed DDC Controls)

Model: ECON-NC5A



For Use with Bard Single Stage Wall Mount
Air Conditioner and Heat Pump Models:

W3SAC, W4SAC, W5SAC
W42AC, W48AC, W60AC, W72AC
W42HC, W48HC, W60HC



Climate Control Solutions

Bard Manufacturing Company, Inc.
Bryan, Ohio 43506
www.bardhvac.com

Manual: 2100-755
Supersedes: **NEW**
Date: 3-11-21

CONTENTS

General Information3

Economizer Model Nomenclature	3
General Economizer Information	3
Unpacking (Field Installation Only)	3
Kit Components (Field Installation Only).....	3
Service	4

Installation of Field-Installed ECON-NC5.....5

Basic Installation.....	5
Blade Adjustment for Desired Ventilation Air	10

GRAPHS

Graph 1 W3SAC ECON-NC Ventilation Delivery... 17	17
Graph 2 W42°C ECON-NC Ventilation Delivery ... 17	17
Graph 3 W4SAC and W48°C ECON-NC Ventilation Delivery	18
Graph 4 W5SAC and W60°C ECON-NC Ventilation Delivery	18
Graph 5 W72AC ECON-NC Ventilation Delivery... 19	19

FIGURES

Figure 1 Disconnect Power	5
Figure 2 Remove Side Grilles	5
Figure 3 Remove Blower Door and Control Panel Cover	5
Figure 4 Remove Blank Off Plates (Both Sides)....	6
Figure 5 Remove Exhaust Blank Off Plate	6
Figure 6 Remove Air Filters and Low Voltage Control Panel Cover.....	6
Figure 7 Install Outdoor Air Sensor	6
Figure 8 Route Sensor Wires and Fasten to Motor Mount.....	7
Figure 9 Remove Wire Channel Covers	7
Figure 10 Install 3000-1627 Wire Harness	7
Figure 11 Route Wires into Wire Channel and Connect to Wire Harness.....	7
Figure 12 Pull Wire into Exhaust Area and Fasten with Ties.....	8
Figure 13 Install Economizer	8
Figure 14 Control Plug Centered in Plug Access Opening	8
Figure 15 Connect Economizer Power Plug to Control Panel Plug	8
Figure 16 Release the Exhaust Blade.....	9
Figure 17 Exhaust Blade and Latch	9
Figure 18 Install Intake Sealing Frame and Lower Block Off Plates	9
Figure 19 Install Mist Filters.....	9
Figure 20 Install Bug Screen and Gaskets	10
Figure 21 Programmable Thermostat Connections for ECON-NC5 with Single Stage Air Conditioners	11
Figure 22 Programmable Thermostat Connections for ECON-NC5 with 2-Stage Air Conditioners	12
Figure 23 Programmable Thermostat Connections for ECON-NC5 with Heat Pumps	13
Figure 24 Non-Programmable Thermostat Connections for ECON-NC5 with Single Stage Air Conditioners.....	14
Figure 25 Non-Programmable Thermostat Connections for ECON-NC5 with 2-Stage Air Conditioners.....	15
Figure 26 Non-Programmable Thermostat Connections for ECON-NC5 with Heat Pumps	16
Figure 27 Call for Ventilation With or Without Compressor Operation	20
Figure 28 Call for Compressor or Fan Only with Ventilation Off	20
Figure 29 Wiring Diagram	21
Figure 30 Lubrication Points.....	22

Economizer with Exhaust Model Nomenclature

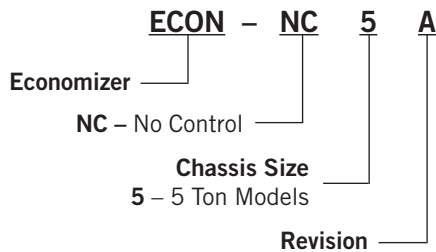

General Economizer Information

Using an economizer provides economical cooling without the need for running the compressor and refrigeration system when outdoor conditions are acceptable to bring air into the building. By bringing in outdoor air to cool a building, energy use is reduced to the power required to operate the indoor fan and the economizer controls. Energy use is a fraction of the power required to operate the refrigeration system. The following benefits can be attributed to the economizer:

- Reduced energy costs when outdoor conditions are acceptable to bring air into the building.
- Lengthen the life expectancy of the refrigeration components due to lower operating time.
- Provide a source of air for an occupied area to meet building code requirements.
- Reduce stress to refrigeration equipment during extremely cold outdoor temperatures by using outdoor air to cool.

Economizer usage is beneficial for several applications including equipment cooling and keeping occupants comfortable while keeping energy costs at a minimum. The ECON-NC model will be discussed in this manual.

The ECON-NC economizer does not contain factory-mounted controls to operate the damper assembly. The economizer allows outdoor air to enter the building when field supplied controls send a 0-10VDC signal to the damper motor. The assembly will also allow room air to be exhausted out of the building.

Typical equipment cooling applications will use field supplied DDC building management controls or a field installed economizer control. The ECON-NC economizer does not include factory-mounted sensors. Additional sensors may be ordered factory or as a kit to be field installed as a “V” controls option (DDC controls sensor package). See wall mount unit specifications and documentation for more information about the “V” controls option.

The economizer system consists of the following key features and components:

- Openings in the sides of the unit that allow outdoor air to enter the wall mount unit. A coarse filter covers the opening to reduce debris and moisture entry into the unit. Once the air enters the unit, it is drawn through the filter located above the vent area, and is transferred into the building by the indoor blower.
- An opening in the front of the unit that allows pressurized indoor air to leave the building. A corrosion-resistant screen covers the opening.
- Three blades located inside the economizer assembly that control the amount of air entering and leaving the building.
- A fully modulating spring return damper motor with a control arm, connecting rods and blade linkages that operate the economizer blades.
- Terminals to connect the field-supplied controls.

Overall, this manual is designed to explain how to field install the economizer, how the economizer functions and discuss economizer setup procedures. If this manual is being supplied with a wall mount unit that already has a factory-installed economizer, it may not be necessary to review the field installation portion of this manual.

Unpacking (Field Installation Only)

Upon receipt of the equipment be sure to compare the model number found on the shipping label with the accessory identification information on the ordering and shipping document to verify that the correct accessory has been shipped.

Inspect the carton housing of each economizer as it is received, and before signing the freight bill, verify that all items have been received and that there is no visible damage (check parts list below). Note any shortages or damage on all copies of the freight bill. The receiving party must contact the last carrier immediately, preferably in writing, requesting inspection by the carrier’s agent. Concealed damage not discovered until after loading must be reported to the carrier within 15 days of its receipt.

Kit Components (Field Installation Only)

The economizer should only be installed by a trained heating and air conditioning technician. These instructions serve as a guide to the technician installing the economizer package. They are not intended as a step-by-step procedure with which the mechanically inclined owner can install the package.

The economizer is shipped in one carton which contains the electrical harness, miscellaneous hardware and installation instructions.

Economizer kit includes:

- ECON-NC5 ventilator
- 910-2017 sensor assembly
- 3000-1627 wire assembly
- 7003-084 mist filter (2)
- 7003-083 exhaust bug screen
- 1913-002-0808 8-1/2" foam strip (2)
- 1913-002-0708 7-1/2" foam strip (4)
- 539-405 intake sealing frame (2)
- 543-223 lower block off plate (2)
- #10-16x1/2 screw (12)
- #8-18x3/8 pan head screw (4)
- 2100-755 installation instructions

Service

The low leakage ventilators/economizers use stainless steel intake blade seals. It is recommended that the side seals, ball joints, and blade hinges be lubricated with a graphite dry lubricant once a year or during filter changes (see Figure 30 on page 22).

INSTALLATION OF FIELD-INSTALLED ECON-NC5

Basic Installation

WARNING

Electrical shock hazard.
Disconnect remote electrical power supply or supplies before servicing.
Failure to do so could result in electric shock or death.

WARNING

Exposed moving parts.
Disconnect electrical power before servicing.
Failure to do so could result in severe injury or amputation.

CAUTION

Cut hazard.
Wear gloves to avoid contact with sharp edges.
Failure to do so could result in personal injury.

Disconnect all power to unit (see Figure 1).

FIGURE 1
Disconnect Power



Remove both side grilles (see Figure 2).

FIGURE 2
Remove Side Grilles



Remove upper blower door, outer control panel cover and front (lower) condenser grille (see Figure 3).

FIGURE 3
Remove Blower Door, Outer Control Panel Cover and Condenser Grille

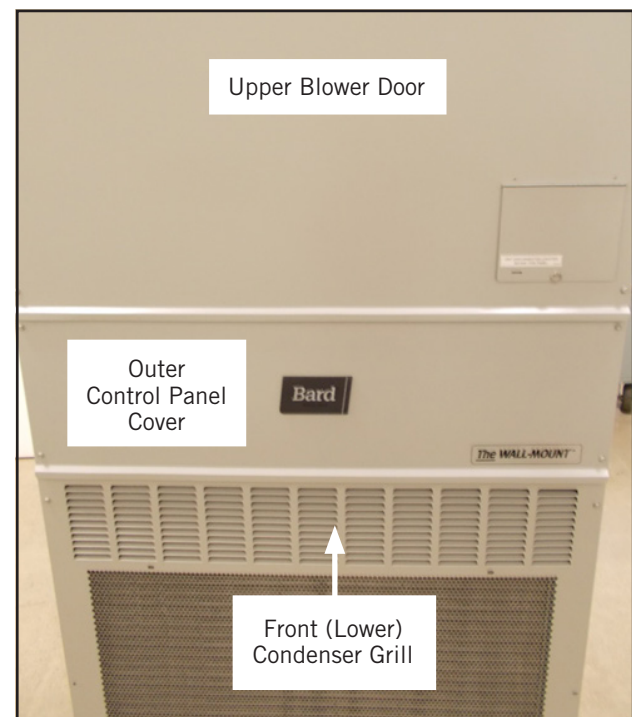

Remove blank off plates (both sides) and discard (see Figure 4). Retain all screws for use with new vent.

FIGURE 4
Remove Blank Off Plates (Both Sides)



Remove exhaust blank off plate through return or through side intake openings and discard (see Figure 5).

FIGURE 5
Remove Exhaust Blank Off Plate

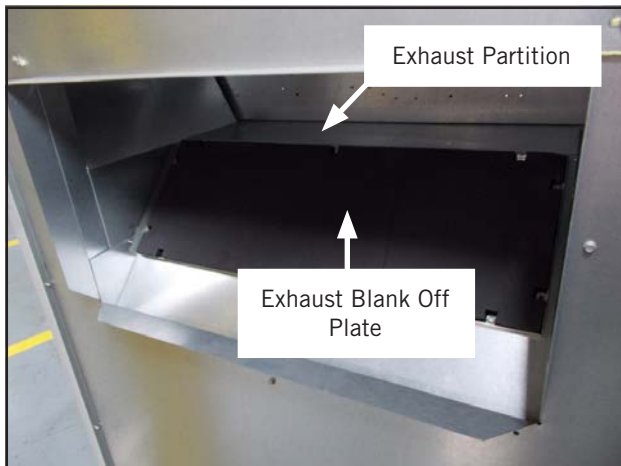

Remove both air filters and the low voltage inner control panel cover (see Figure 6). Remove left filter first then slide right filter to the left to remove.

FIGURE 6
Remove Air Filters and Low Voltage Control Panel Cover

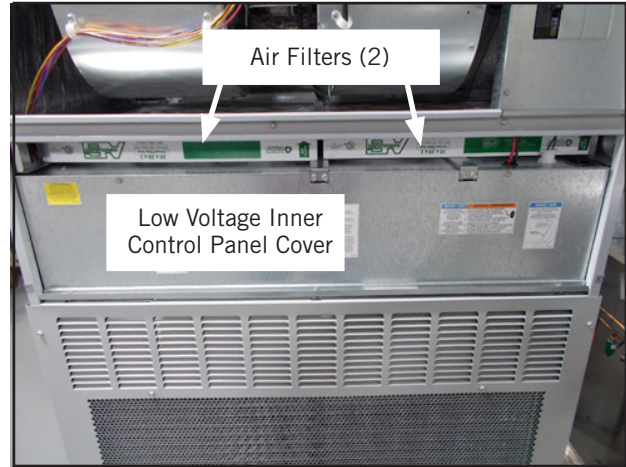

Install the 8301-066 outdoor air sensor as shown in Figure 7 using the holes provided with two (2) #10-16x1/2 screws. View shown from left side.

FIGURE 7
Install Outdoor Air Sensor



Route the sensor wires over the top of the outdoor fan motor and up through the condenser partition bushing. Fasten the wires to the motor mount as shown in Figure 8 using four (4) 7950-004 ladder ties provided.

FIGURE 8
Route Sensor Wires and Fasten to Motor Mount



Remove wire channel covers (see Figure 9).

FIGURE 9
Remove Wire Channel Covers



Install the 3000-1627 wire harness: The 4 pin connector snaps into the back of the control panel for the economizer to plug into, the 12 pin connector plugs into the low voltage box and the orange wires run in the wire channel and plug onto the sensor wires. See Figure 10.

FIGURE 10
Install 3000-1627 Wire Harness

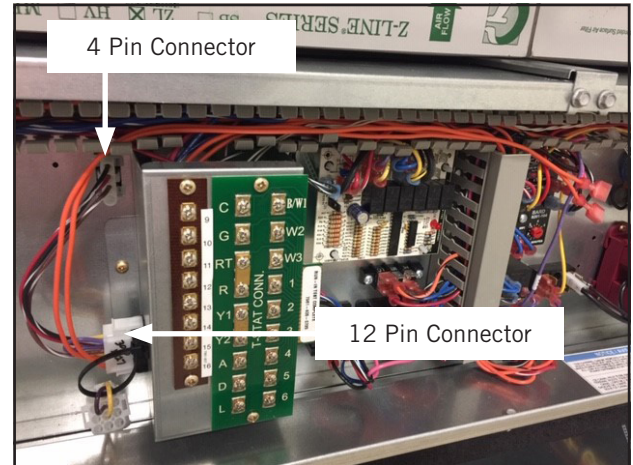

Route the orange sensor wires up through the lower control panel bushing and into the wire channel (see Figure 11). Plug the wires into the 3000-1627 wire harness that plugs into the 12 pin low voltage connector.

FIGURE 11
Route Wires into Wire Channel and Connect to Wire Harness

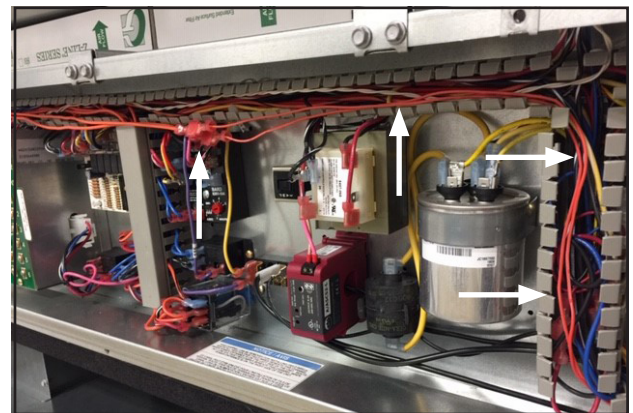

Pull the excess sensor wire down into the exhaust area and fasten with two (2) 7950-004 ladder ties.

FIGURE 12
Pull Wire into Exhaust Area and Fasten with Ties



Before installing, remove economizer from packaging and verify there is no damage. Install the economizer as shown in Figure 13.

Set economizer on the exhaust partition (see Figure 5 on page 6) and slide in until flush with the side of the wall mount. Economizer can be installed from either side.

FIGURE 13
Install Economizer



When the economizer is fully installed, the control plug should be centered in the plug access opening on the front panel of the economizer as shown in Figure 14.

FIGURE 14
Control Plug Centered in Plug Access Opening

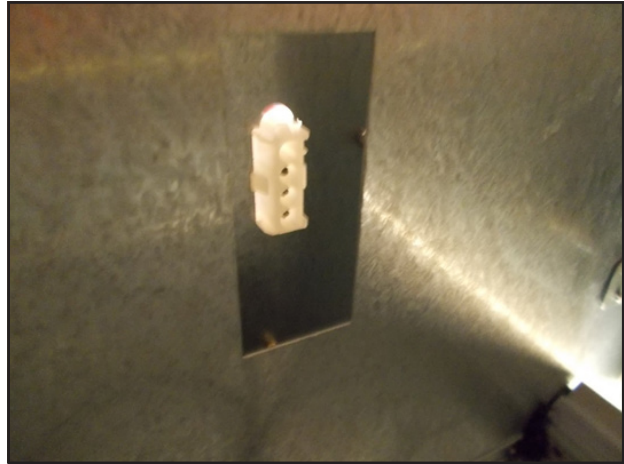

From the front, through the filter opening, plug the economizer power plug into the control panel plug (see Figure 15).

IMPORTANT: Sharp edges--PPE required.

FIGURE 15
Connect Economizer Power Plug to Control Panel Plug

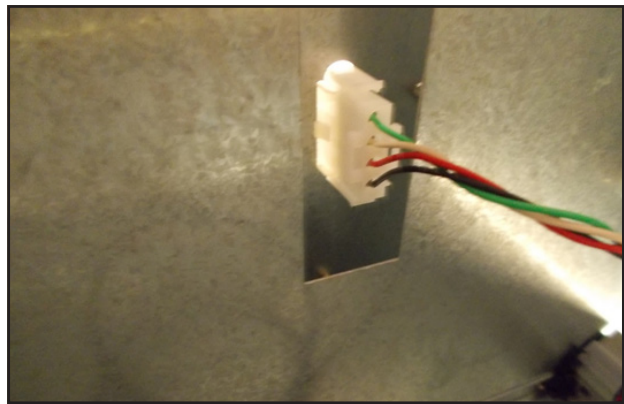

The ECON-NC5 exhaust blade is fixed in the shipping position by the latch located on the bottom of the blade (see Figure 16). Access can be made through the return air opening or through the opening under the economizer. Turning the latch 1/4 turn will release the blade.

FIGURE 16
Release the Exhaust Blade



Make sure the blade seats correctly over the exhaust opening and that the latch is as shown in Figure 17.

FIGURE 17
Exhaust Blade and Latch



Install the 539-405 intake sealing frame and the 543-223 lower block off plates (both sides) as shown in Figure 18. Install two (2) 1913-002-0708 7-1/2" foam gaskets below the intake sealing frame (both sides).

FIGURE 18
Install Intake Sealing Frame and Lower Block Off Plates

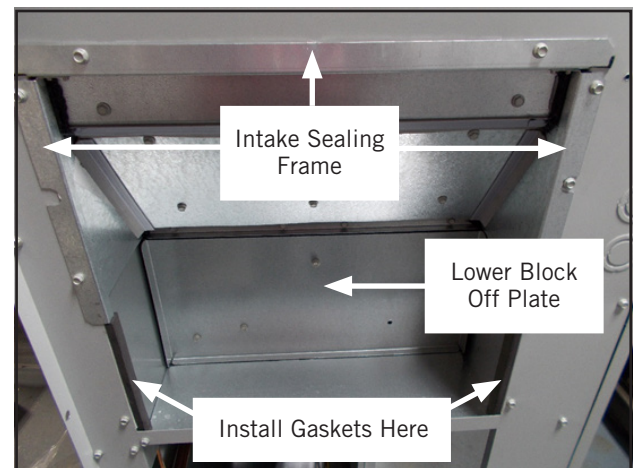

Bend the two (2) sheet metal tabs in the condenser partition up to hold the bottom of the mist eliminator in place.

Install 7003-084 mist filters on both sides (see Figure 19). Then re-install the side grilles removed earlier.

FIGURE 19
Install Mist Filters



Bend the two (2) sheet metal tabs in the condenser partition up to hold the bottom of the bug screen in place.

Install two (2) 1913-002-0808 8-1/2" foam gaskets to sides of cabinet (see Figure 20). Install the 7003-083 exhaust bug screen. Re-install front lower (condenser) grille.

FIGURE 20
Install Bug Screen and Gaskets

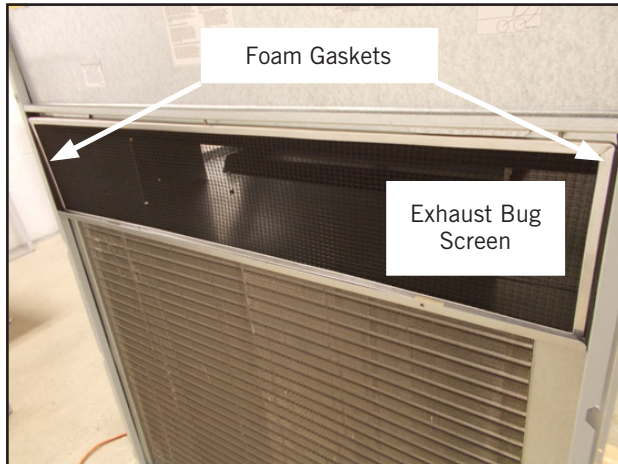

Restore power to unit.

Refer to airflow charts on pages 17 – 19 for fresh air CFM vs. voltage input to economizer.

Blade Adjustment for Desired Ventilator Air

The amount of ventilation air supplied by the economizer is dependant on four factors.

1. Return air duct static pressure drop.
2. Supply air duct static pressure drop.
3. Indoor blower motor speed.
4. Damper blade open position setting.

Refer to the appropriate graph on pages 17 – 19 to determine the blade setting.

FIGURE 21
Programmable Thermostat Connections for ECON-NC5 with Single Stage Air Conditioners

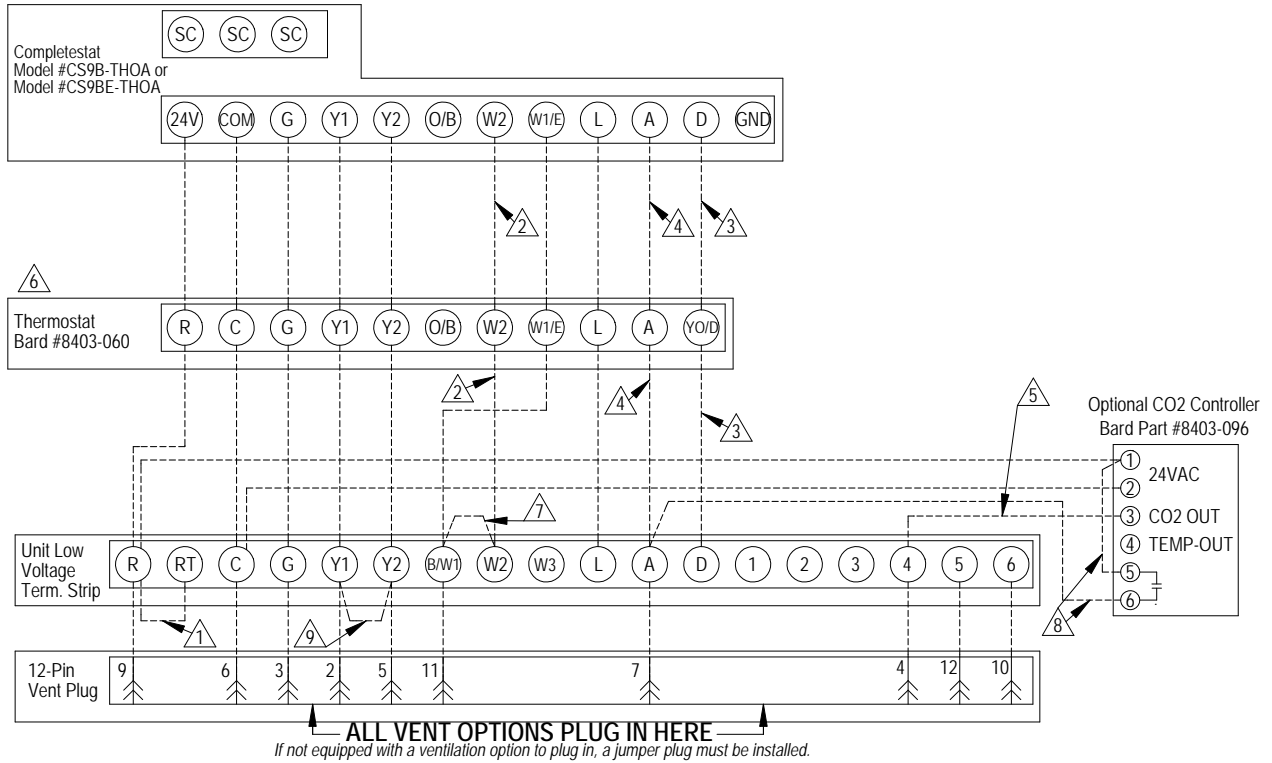

- △1 Factory installed jumper. Remove jumper and connect to N.C fire alarm circuit if emergency shutdown required.
- △2 Wire not needed below 15KW.
- △3 Wire required for dehumidification models only.
- △4 Do not connect "A" from thermostat if optional CO2 controller is used
- △5 0-10 VDC modulating CO2 control signal for modulating ventilation control (optional for ECON only - see vent instruction manuals)

- △6 Change model configuration from heat pump to heat/cool. Must be configured to programmable and fan set to be programmed fan for the "A" output to function during scheduled occupied periods. Must be configured for multi-stage for Y1 output to be active 1st stage cooling. For dehumidification, must be configured for "No Economizer" for YO/D to be active for humidity control.
- △7 Install jumper for 1 stage electric heat on units with less than 15KW
- △8 Do not add these wires if setting up for modulating control. See note 5.
- △9 Factory installed jumper. Remove jumper to activate Balanced Climate™ mode. A 2-stage thermostat is recommended for Balanced Climate mode.

MIS-3974 C

FIGURE 22
Programmable Thermostat Connections for ECON-NC5 with 2-Stage Air Conditioners

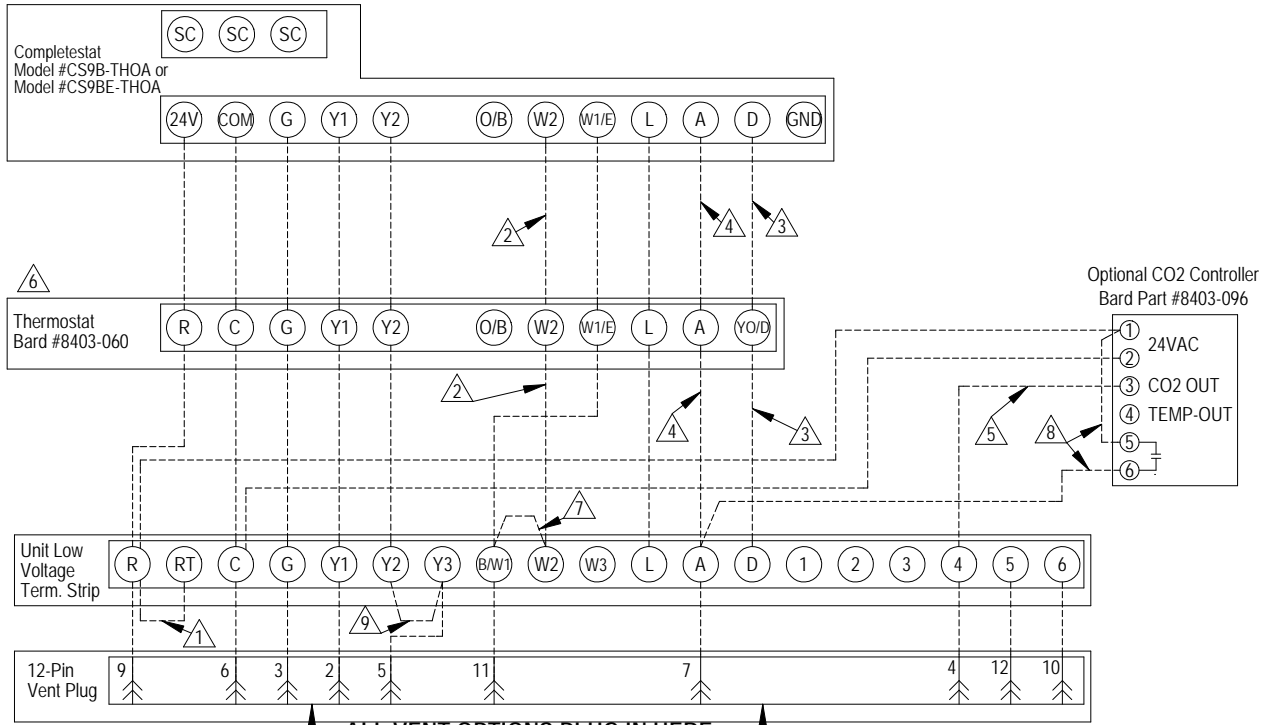

ALL VENT OPTIONS PLUG IN HERE
If not equipped with a ventilation option to plug in, a jumper plug must be installed.

- | | |
|--|--|
| <p>1 Factory installed jumper. Remove jumper and connect to N.C fire alarm circuit if emergency shutdown required.</p> <p>2 Wire not needed below 15KW.</p> <p>3 Wire required for dehumidification models only.</p> <p>4 Do not connect "A" from thermostat if optional CO2 controller is used</p> <p>5 0-10 VDC modulating CO2 control signal for modulating ventilation control (optional for ECON only - see vent instruction manuals)</p> | <p>6 Change model configuration from heat pump to heat/cool. Must be configured to programmable and fan set to be programmed fan for the "A" output to function during scheduled occupied periods. Must be configured for multi-stage for Y1 output to be active 1st stage cooling. For dehumidification, must be configured for "No Economizer" for YO/D to be active for humidity control.</p> <p>7 Install jumper for 1 stage electric heat on units with less than 15KW</p> <p>8 Do not add these wires if setting up for modulating control. See note 5.</p> <p>9 Factory installed jumper. Must not be removed when Econ is installed.</p> |
|--|--|

MIS-4291

FIGURE 23
Programmable Thermostat Connections for ECON-NC5 with Heat Pumps

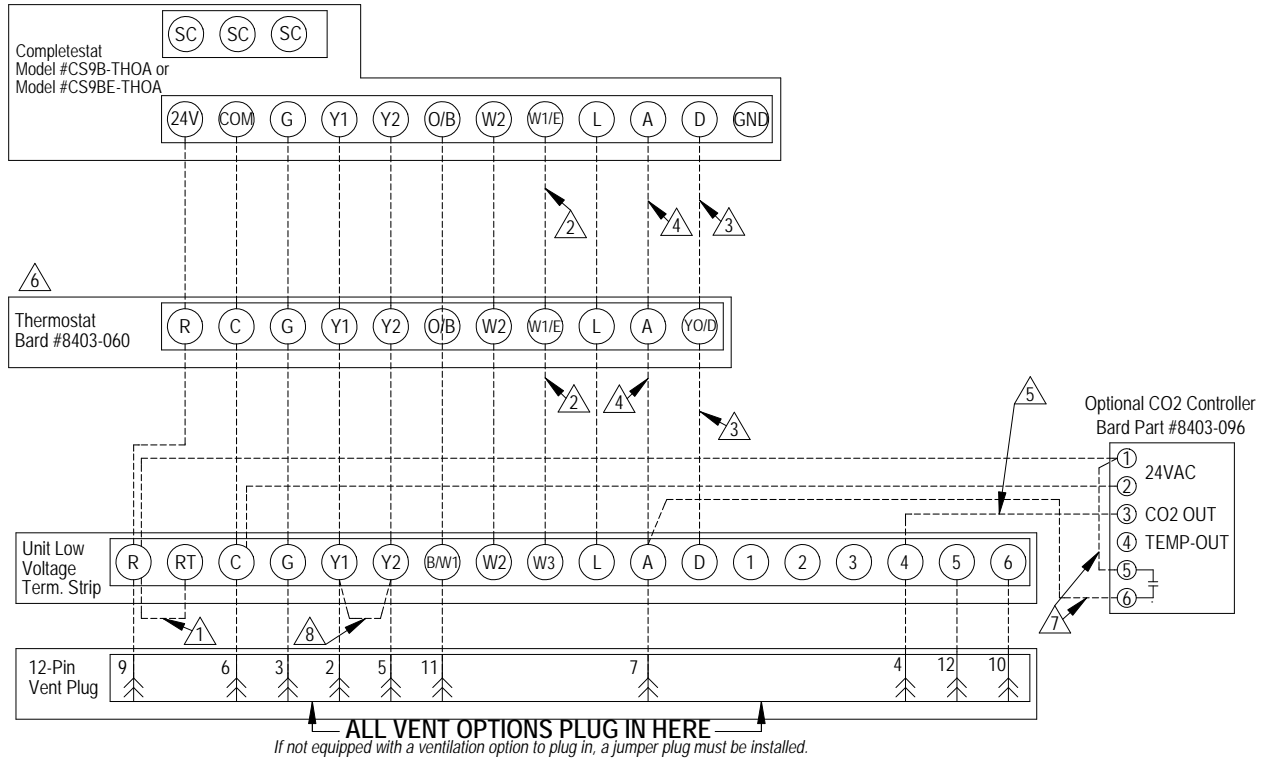

- | | |
|---|---|
| <ul style="list-style-type: none"> ① Factory installed jumper. Remove jumper and connect to N.C fire alarm circuit if emergency shutdown required. ② Wire not needed below 15KW. ③ Wire required for dehumidification models only. ④ Do not connect "A" from thermostat if optional CO2 controller is used ⑤ 0-10 VDC modulating CO2 control signal for modulating ventilation control (optional for ECON only - see vent instruction manuals) | <ul style="list-style-type: none"> ⑥ Ensure model configuration is heat pump and not heat/cool. Must be configured to programmable and fan set to be programmed fan for the "A" output to function during scheduled occupied periods. Must be configured for multi-stage for Y1 output to be active 1st stage cooling. For dehumidification, must be configured for "No Economizer" for YO/D to be active for humidity control. ⑦ Do not add these wires if setting up for modulating control. ⑧ Factory installed jumper. Jumper is not installed on unit with economizers. Jumper is located in jade wiring harness. |
|---|---|

MIS-4063 D

FIGURE 24
Non-Programmable Thermostat Connections for ECON-NC5 with Single Stage Air Conditioners

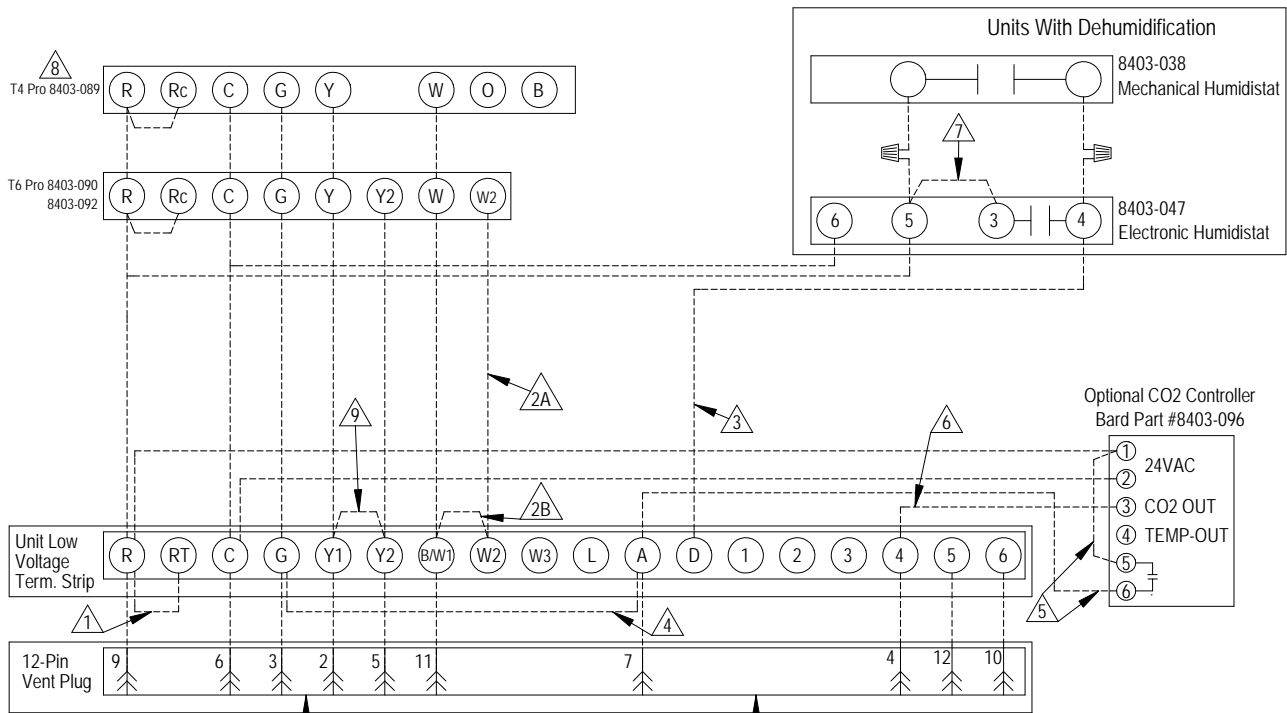

ALL VENT OPTIONS PLUG IN HERE

If not equipped with a ventilation option to plug in, a jumper plug must be installed.

- | | |
|--|--|
| <p>1 Factory installed jumper. Remove jumper and connect to N.C fire alarm circuit if emergency shutdown required.</p> <p>2A Wire not needed below 15KW.</p> <p>2B Install Jumper for 1 stage electric heat on units with more than 10KW.</p> <p>3 Wire required for dehumidification models only.</p> <p>4 For vent operation, add jumper if optional CO2 controller is not used. Vent will run while blower is energized. For ECON & CRV-V an additional wire change is required See install Manual.</p> <p>5 Do not add these wires if setting up for modulating control. See note 6.</p> | <p>6 0-10 VDC Modulating CO2 control signal for modulating ventilation control (Optional for ECON Only) - See vent installation manual.</p> <p>7 Jumper needs added.</p> <p>8 Thermostat will not work with units equipped with economizers.</p> <p>9 Factory installed jumper. Remove jumper to activate Balanced Climate™ Mode. A 2-stage thermostat is recommended for Balanced Climate mode.</p> |
|--|--|

MIS-3975 D

FIGURE 25
Non-Programmable Thermostat Connections for ECON-NC5 with 2-Stage Air Conditioners

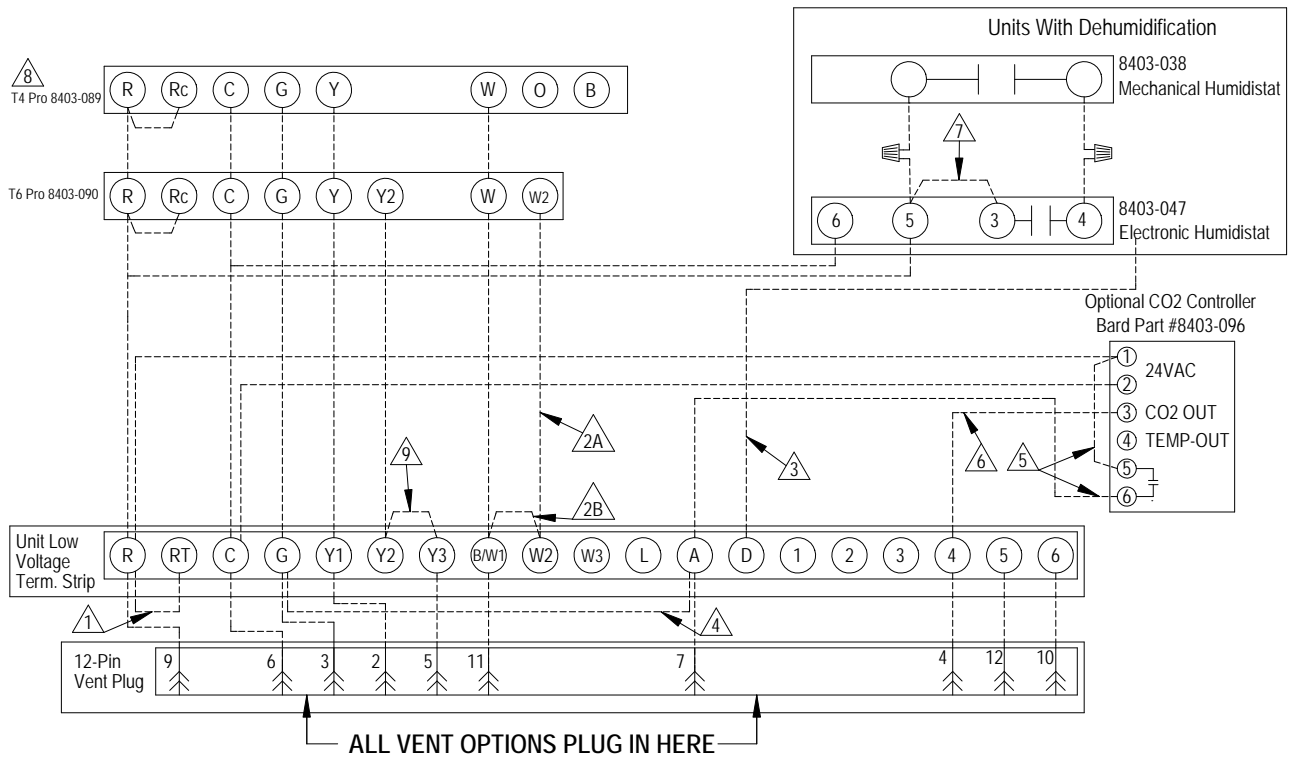

ALL VENT OPTIONS PLUG IN HERE

If not equipped with a ventilation option to plug in, a jumper plug must be installed.

- | | |
|---|--|
| <ul style="list-style-type: none"> ① Factory installed jumper. Remove jumper and connect to N.C fire alarm circuit if emergency shutdown required. ②A Wire not needed below 15KW. ②B Install Jumper for 1 stage electric heat on units with more than 10KW. ③ Wire required for dehumidification models only. ④ For vent operation, add jumper if optional CO2 controller is not used. Vent will run while blower is energized. For ECON & CRV-V an additional wire change is required See install Manual. ⑤ Do not add these wires if setting up for modulating control. See note 6. | <ul style="list-style-type: none"> ⑥ 0-10 VDC Modulating CO2 control signal for modulating ventilation control (Optional for ECON Only) - See vent installation manual. ⑦ Jumper needs added. ⑧ Thermostat will not work with units equipped with economizers. ⑨ Factory installed jumper. Must not be removed when Econ is installed. |
|---|--|

MIS-4292

FIGURE 26
Non-Programmable Thermostat Connections for ECON-NC5 with Heat Pumps

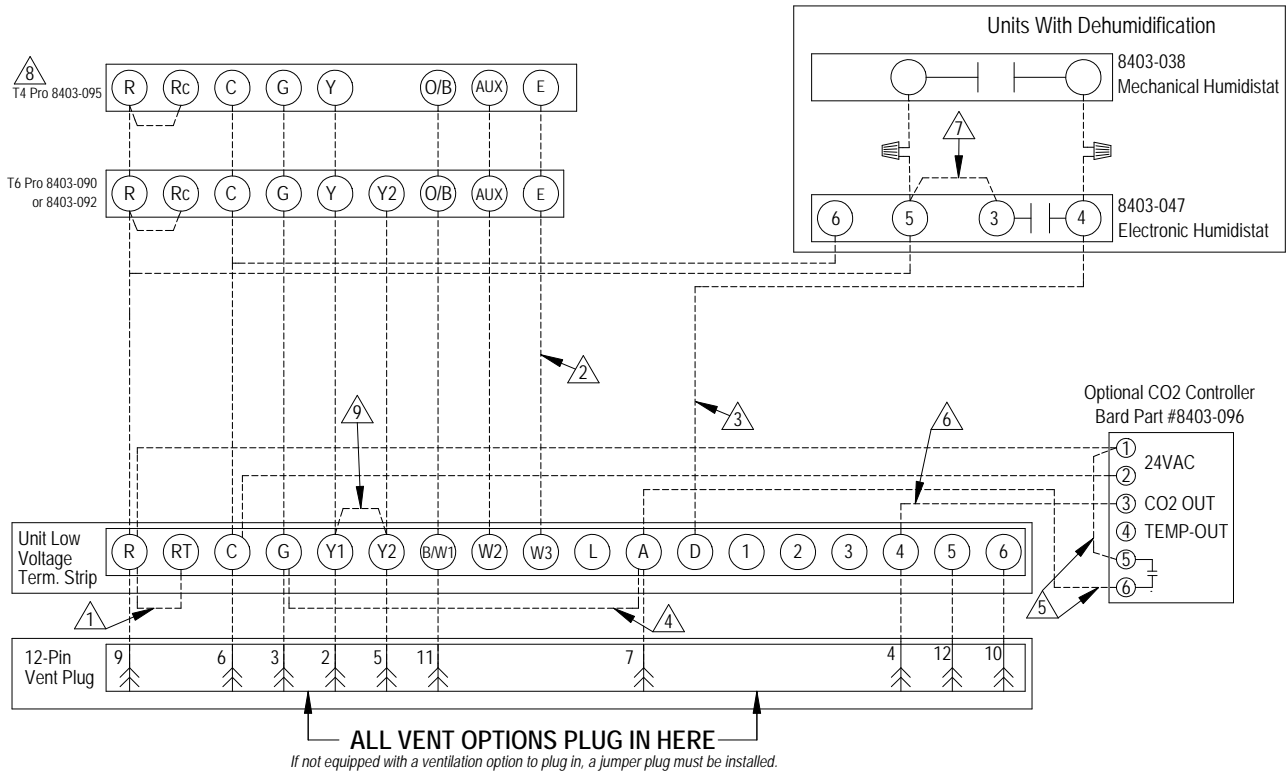

- ① Factory installed jumper. Remove jumper and connect to N.C fire alarm circuit if emergency shutdown required.
- ② Wire not needed below 15KW.
- ③ Wire required for dehumidification models only.
- ④ For vent operation, add jumper if optional CO2 controller is not used. Vent will run while blower is energized. For ECON & CRV-V, an additional wire change is required. See install manual
- ⑤ Do not add these wires if setting up for modulating control. See note 6.
- ⑥ 0-10 VDC Modulating CO2 control signal for modulating ventilation control (Optional for ECON Only) - See vent installation manual.
- ⑦ Jumper needs added.
- ⑧ Thermostat will not work with units equipped with economizers.
- ⑨ Factory installed jumper. Remove jumper to activate Balanced Climate™ Mode. A 2-stage thermostat is recommended for Balanced Climate mode.

MIS-4064 E

GRAPH 1
W3SAC ECON-NC Ventilation Delivery

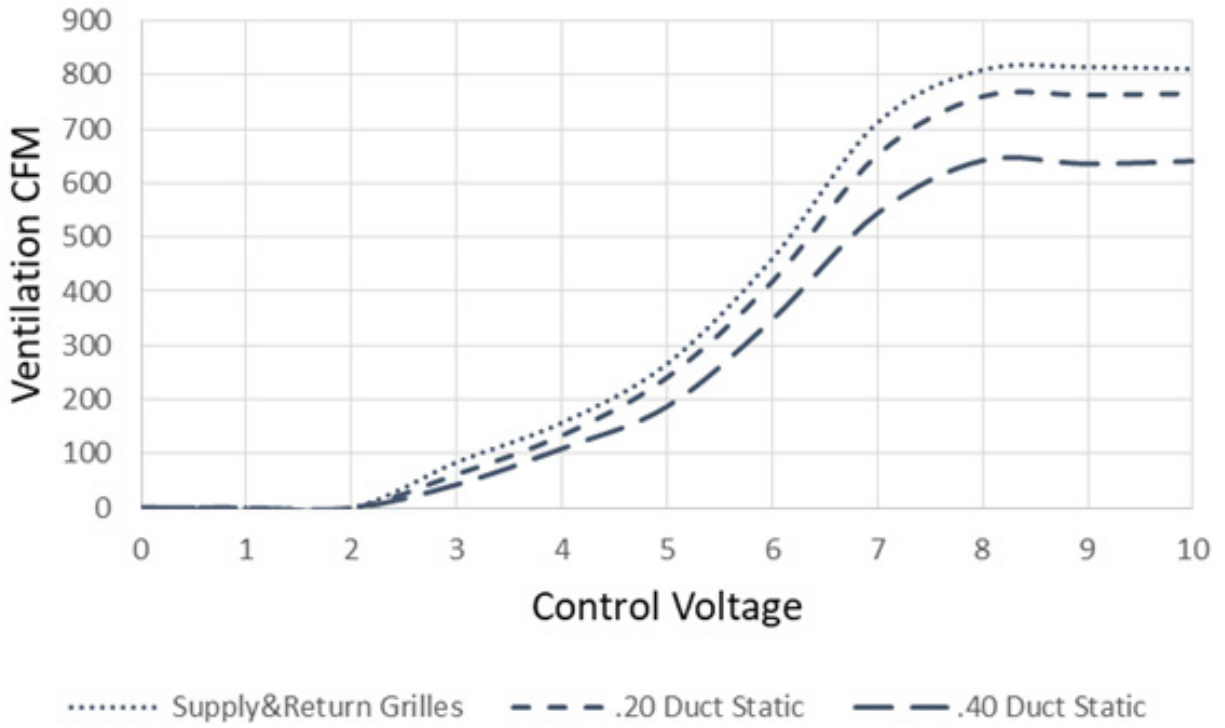

GRAPH 2
W42*C ECON-NC Ventilation Delivery

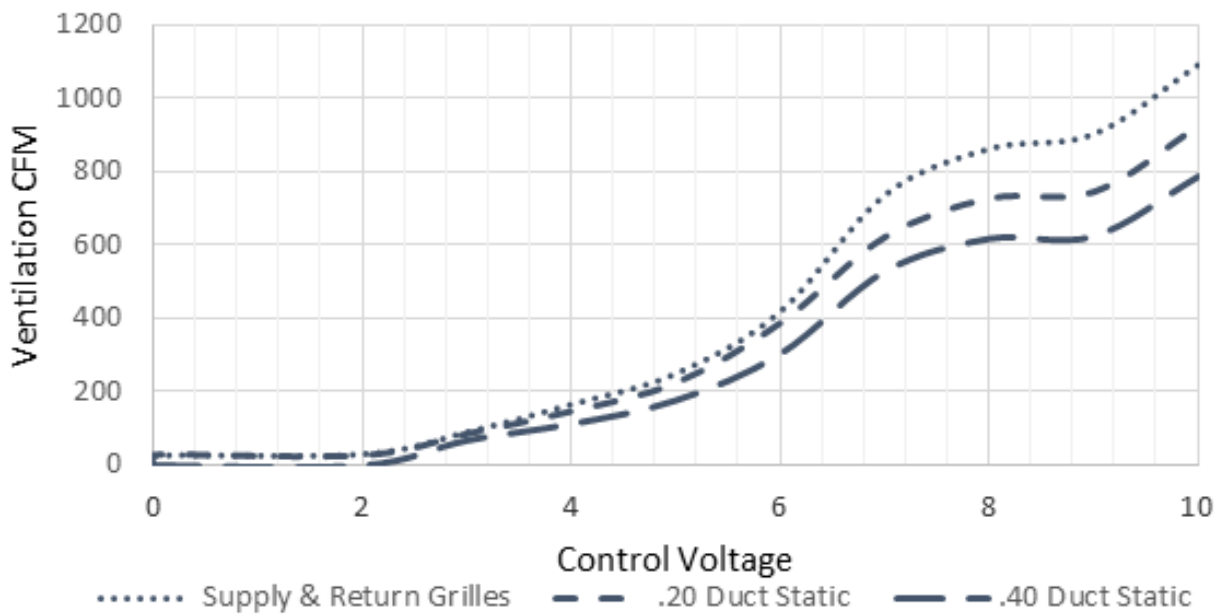

GRAPH 3
W4SAC and W48°C ECON-NC Ventilation Delivery

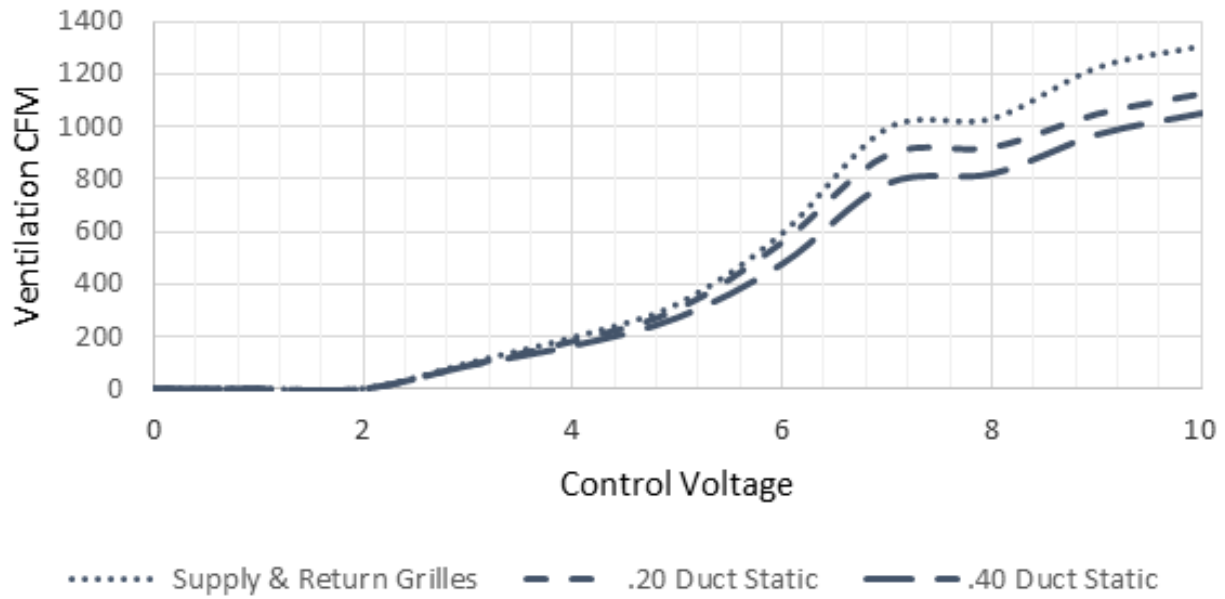

GRAPH 4
W5SAC and W60°C ECON-NC Ventilation Delivery

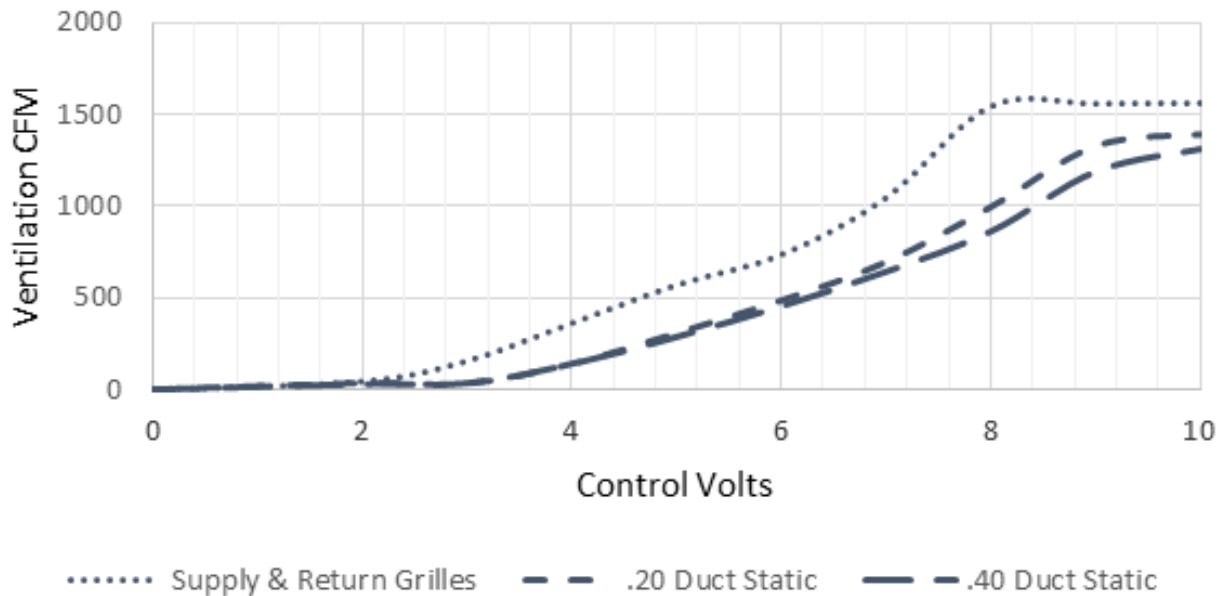

GRAPH 5
W72AC ECON-NC Ventilation Delivery

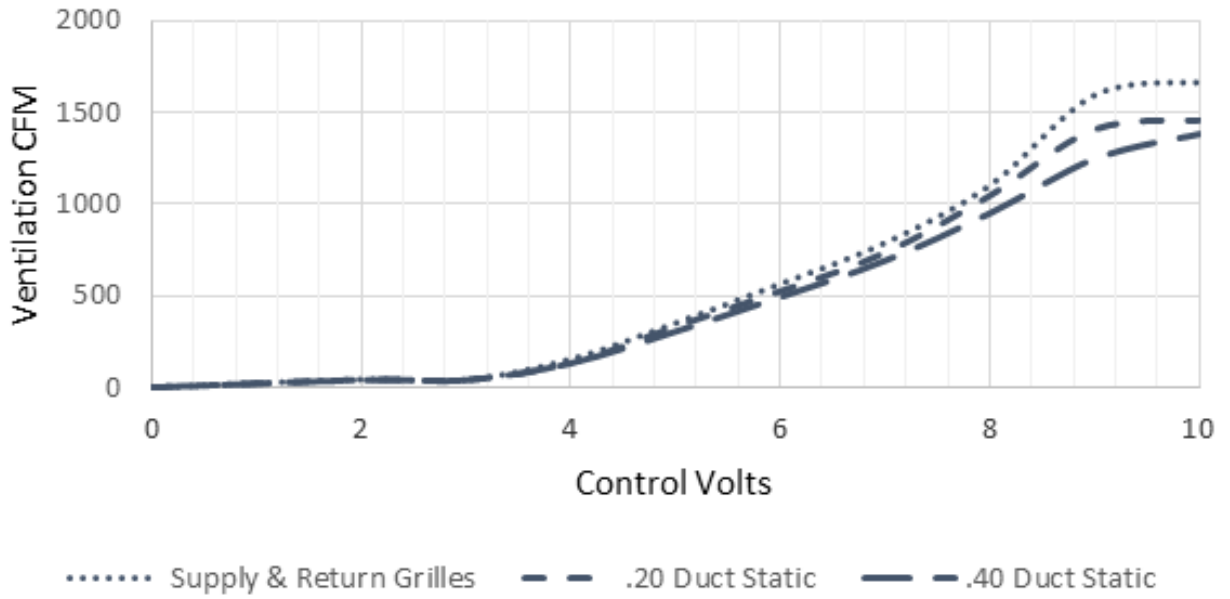
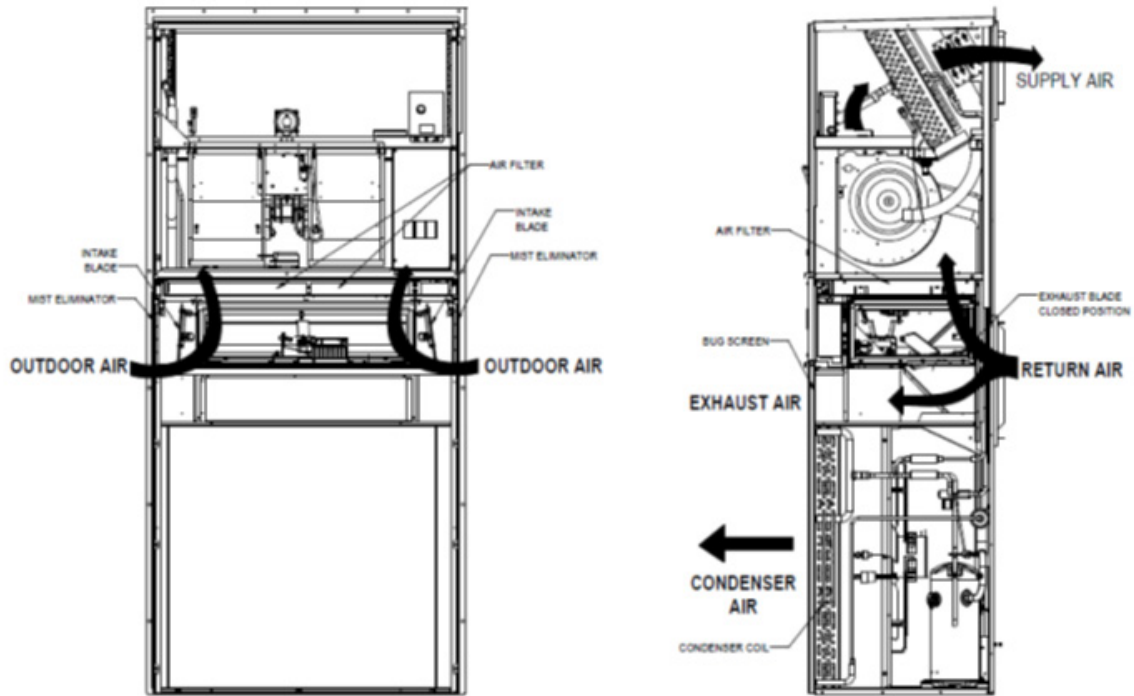
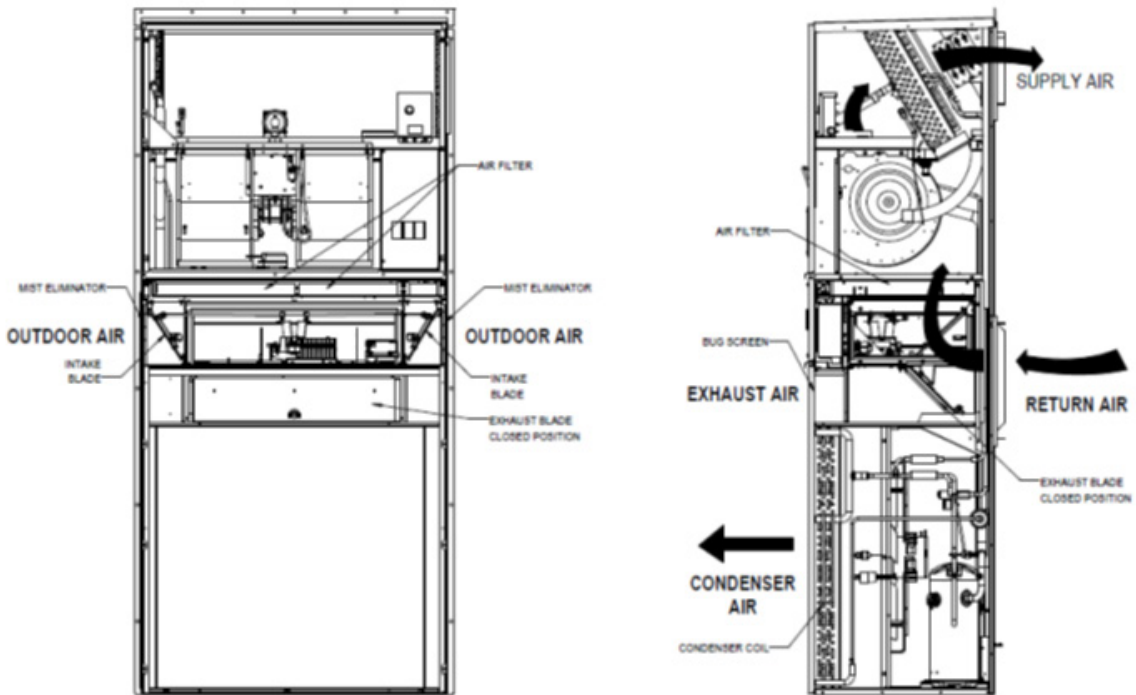

FIGURE 27
Call for Ventilation With or Without Compressor Operation



MIC-4038

FIGURE 28
Call for Compressor or Fan Only with Ventilation Off



MIC-4037

FIGURE 29
Wiring Diagram

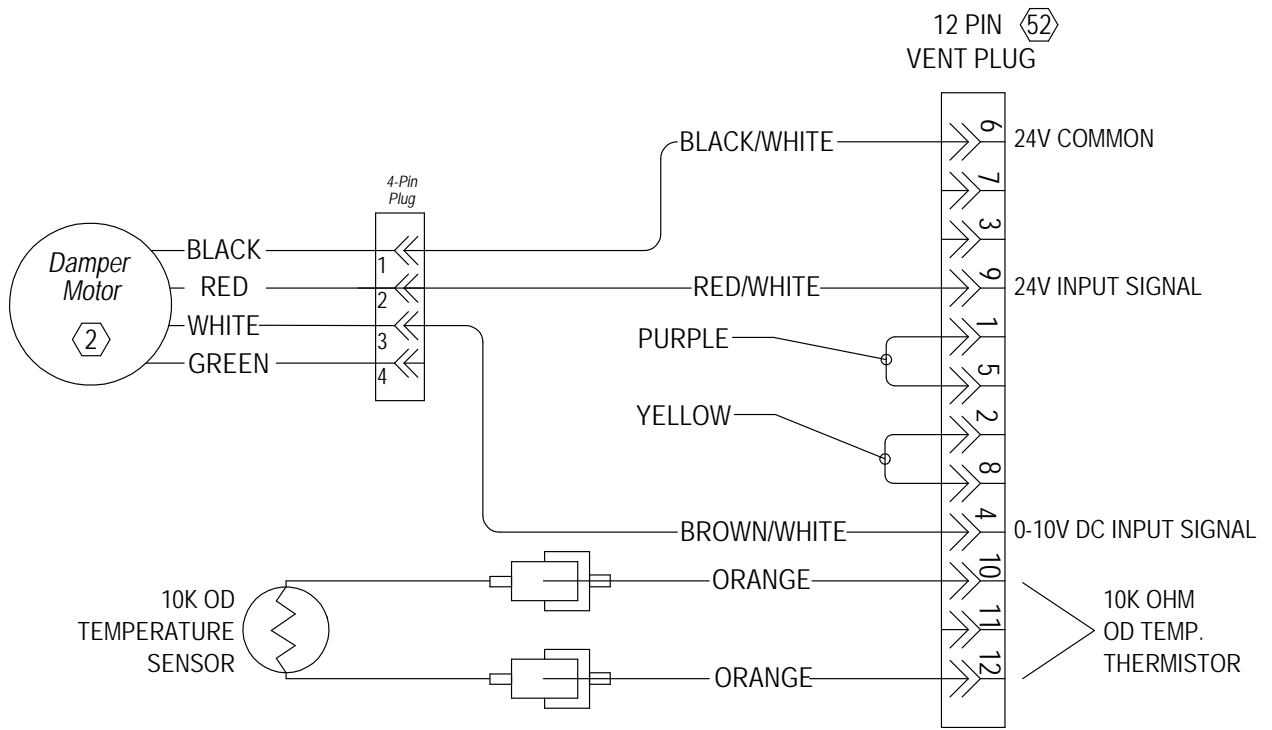

NO CONTROL ECONOMIZER WIRING DIAGRAM

4056-247

FIGURE 30
Lubrication Points

