

Galaxy VX

380 V, 400 V, 415 V, and 440 V UPS System

Technical Specifications

07/2020



Legal Information

The Schneider Electric brand and any trademarks of Schneider Electric SE and its subsidiaries referred to in this guide are the property of Schneider Electric SE or its subsidiaries. All other brands may be trademarks of their respective owners.

This guide and its content are protected under applicable copyright laws and furnished for informational use only. No part of this guide may be reproduced or transmitted in any form or by any means (electronic, mechanical, photocopying, recording, or otherwise), for any purpose, without the prior written permission of Schneider Electric.

Schneider Electric does not grant any right or license for commercial use of the guide or its content, except for a non-exclusive and personal license to consult it on an "as is" basis. Schneider Electric products and equipment should be installed, operated, serviced, and maintained only by qualified personnel.

As standards, specifications, and designs change from time to time, information contained in this guide may be subject to change without notice.

To the extent permitted by applicable law, no responsibility or liability is assumed by Schneider Electric and its subsidiaries for any errors or omissions in the informational content of this material or consequences arising out of or resulting from the use of the information contained herein.



Go to: https://www.productinfo.schneider-electric.com/galaxyvx_iec/
or scan the QR code above for digital experience and translated manuals.

Table of Contents

Important Safety Instructions — SAVE THESE	
INSTRUCTIONS	5
Electromagnetic Compatibility	6
Safety Precautions	6
Technical Data	8
System Overview	8
Model List	9
Overview of Configurations	10
Overview of UPSs with 1250 kW I/O Cabinet - Single Utility/ Mains	10
Overview of UPSs with 1250 kW I/O Cabinet - Dual Utility/Mains	11
Overview of UPSs with 1500 kW I/O Cabinet – Single Utility/ Mains	11
Overview of UPSs with 1500 kW I/O Cabinet – Dual Utility/Mains	12
Input Power Factor	12
Input Voltage Window	13
Inverter Short-Circuit Capabilities (Bypass not Available)	15
Efficiency for UPSs with 1250 kW I/O Cabinet	16
Efficiency for UPSs with 1500 kW I/O Cabinet	18
Derating Due to Load Power Factor	20
Batteries	21
Battery Runtimes for Li-Ion Battery Cabinets LIBATTSMGGIEC	21
End of Discharge Voltage	23
Battery Voltage Range	23
Compliance	24
Communication and Management	24
EPO Connections	24
Overview of Input Contacts and Output Relays	25
Facility Planning	27
Specifications for 500 kW UPS	27
Specifications for 625 kW UPS	29
Specifications for 750 kW UPS	31
Specifications for 800 kW UPS	33
Specifications for 1000 kW UPS	35
Specifications for 1100 kW UPS	37
Specifications for 1250 kW UPS	39
Specifications for 1500 kW UPS	41
Recommended Upstream Protection and Cable Sizes – IEC	42
Weights and Dimensions	45
Weights and Dimensions for UPSs with 1250 kW I/O Cabinet	45
Weights and Dimensions for UPSs with 1500 kW I/O Cabinet	46
Clearance	46
Clearance for UPSs with 1250 kW I/O Cabinet	46
Clearance for UPSs with 1500 kW I/O Cabinet	46
Guidance for Organizing Battery Cables	47
Torque Specifications	47
Environment	48

Heat Dissipation (BTU/hr) for UPSs with 1250 kW I/O Cabinet	48
Heat Dissipation (BTU/hr) for UPSs with 1500 kW I/O Cabinet	51
Options	53
Hardware Options.....	53
Configuration Options	53
Limited Factory Warranty	54

Important Safety Instructions — SAVE THESE INSTRUCTIONS

Read these instructions carefully and look at the equipment to become familiar with it before trying to install, operate, service or maintain it. The following safety messages may appear throughout this manual or on the equipment to warn of potential hazards or to call attention to information that clarifies or simplifies a procedure.



The addition of this symbol to a “Danger” or “Warning” safety message indicates that an electrical hazard exists which will result in personal injury if the instructions are not followed.



This is the safety alert symbol. It is used to alert you to potential personal injury hazards. Obey all safety messages with this symbol to avoid possible injury or death.

DANGER

DANGER indicates a hazardous situation which, if not avoided, **will result in death or serious injury.**

Failure to follow these instructions will result in death or serious injury.

WARNING

WARNING indicates a hazardous situation which, if not avoided, **could result in death or serious injury.**

Failure to follow these instructions can result in death, serious injury, or equipment damage.

CAUTION

CAUTION indicates a hazardous situation which, if not avoided, **could result in minor or moderate injury.**

Failure to follow these instructions can result in injury or equipment damage.

NOTICE

NOTICE is used to address practices not related to physical injury. The safety alert symbol shall not be used with this type of safety message.

Failure to follow these instructions can result in equipment damage.

Please Note

Electrical equipment should only be installed, operated, serviced, and maintained by qualified personnel. No responsibility is assumed by Schneider Electric for any consequences arising out of the use of this material.

A qualified person is one who has skills and knowledge related to the construction, installation, and operation of electrical equipment and has received safety training to recognize and avoid the hazards involved.

Electromagnetic Compatibility

NOTICE

RISK OF ELECTROMAGNETIC DISTURBANCE

This is a product Category C3 according to IEC 62040-2. This is a product for commercial and industrial applications in the second environment - installation restrictions or additional measures may be needed to prevent disturbances. The second environment includes all commercial, light industry, and industrial locations other than residential, commercial, and light industrial premises directly connected without intermediate transformer to a public low-voltage mains supply. The installation and cabling must follow the electromagnetic compatibility rules, e.g.:

- the segregation of cables,
- the use of shielded or special cables when relevant,
- the use of grounded metallic cable tray and supports.

Failure to follow these instructions can result in equipment damage.

Safety Precautions

⚠ DANGER

HAZARD OF ELECTRIC SHOCK, EXPLOSION, OR ARC FLASH

- The product must be installed according to the specifications and requirements as defined by Schneider Electric. It concerns in particular the external and internal protections (upstream circuit breakers, battery circuit breakers, cabling, etc.) and environmental requirements. No responsibility is assumed by Schneider Electric if these requirements are not respected.
- After the UPS system has been electrically wired, do not start up the system. Start-up must only be performed by Schneider Electric.

Failure to follow these instructions will result in death or serious injury.

⚠ DANGER

HAZARD OF ELECTRIC SHOCK, EXPLOSION, OR ARC FLASH

The UPS System must be installed according to local and national regulations. Install the UPS according to:

- IEC 60364 (including 60364-4-41- protection against electric shock, 60364-4-42 - protection against thermal effect, and 60364-4-43 - protection against overcurrent), **or**
- NEC NFPA 70

depending on which one of the standards apply in your local area.

Failure to follow these instructions will result in death or serious injury.

⚠ DANGER

HAZARD OF ELECTRIC SHOCK, EXPLOSION, OR ARC FLASH

- Install the UPS system in a temperature controlled area free of conductive contaminants and humidity.
- Install the UPS system on a non-flammable, level, and solid surface (e.g. concrete) that can support the weight of the system.

Failure to follow these instructions will result in death or serious injury.

⚠ DANGER

HAZARD OF ELECTRIC SHOCK, EXPLOSION, OR ARC FLASH

The UPS is not designed for and must therefore not be installed in the following unusual operating environments:

- Damaging fumes
- Explosive mixtures of dust or gases, corrosive gases, or conductive or radiant heat from other sources
- Moisture, abrasive dust, steam or in an excessively damp environment
- Fungus, insects, vermin
- Salt-laden air or contaminated cooling refrigerant
- Pollution degree higher than 2 according to IEC 60664-1
- Exposure to abnormal vibrations, shocks, and tilting
- Exposure to direct sunlight, heat sources, or strong electromagnetic fields

Failure to follow these instructions will result in death or serious injury.

NOTICE

RISK OF OVERHEATING

Respect the clearance requirements around the UPS system and do not cover the product's ventilation openings when the UPS system is in operation.

Failure to follow these instructions can result in equipment damage.

NOTICE

RISK OF EQUIPMENT DAMAGE

Do not connect the UPS output to regenerative load systems including photovoltaic systems and speed drives.

Failure to follow these instructions can result in equipment damage.

Technical Data

System Overview

Each Galaxy VX UPS consists of the following components:

- An I/O cabinet for field wiring containing the static switch, a backfeed protection switch, and the user interface.
- A number of 250 kW power cabinets containing the power electronics.

UPSs with 1250 kW I/O Cabinet

The 1250 kW I/O cabinet is used for UPS systems from a minimum configuration of 500 kW with two power cabinets to a maximum configuration of 1250 kW N+1 with six power cabinets. The I/O cabinet is placed to the left and two to six power cabinets are placed to the right. The image below shows the maximum configuration.

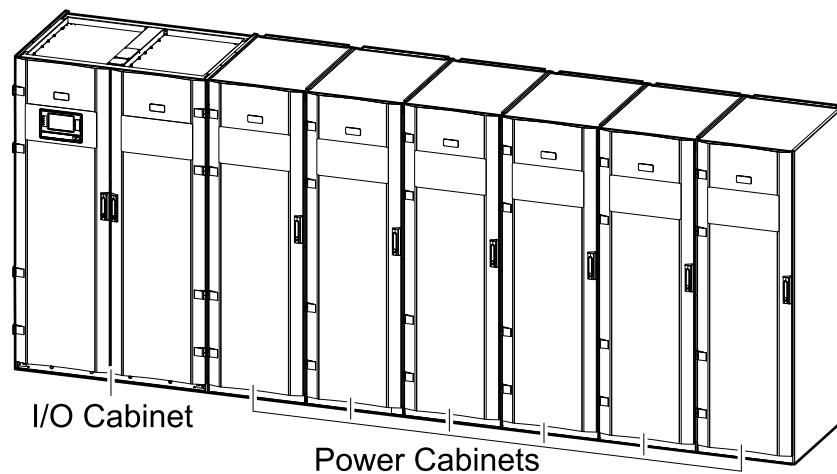

UPSs with 1500 kW I/O Cabinet

The 1500 kW I/O cabinet is used for UPS systems from a minimum configuration of 500 kW with two power cabinets to a maximum configuration of 1500 kW N+1 with seven power cabinets. The image below shows the maximum configuration.

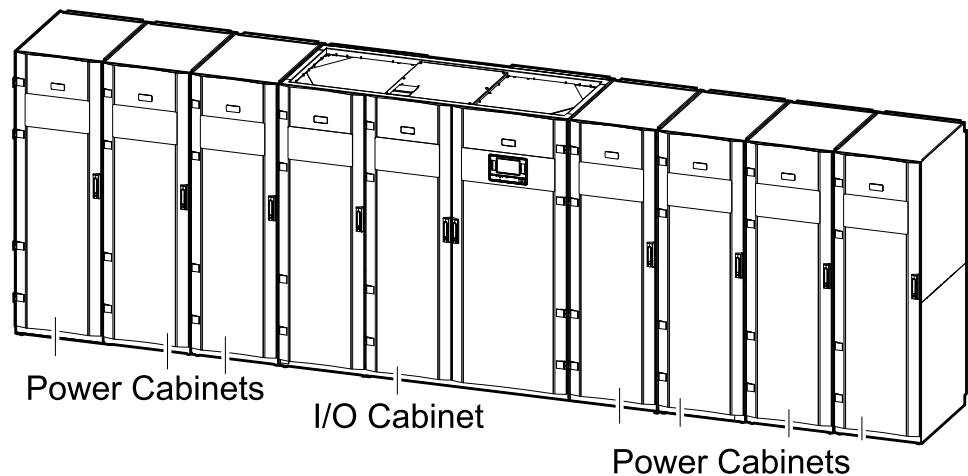

Model List

UPSs with 1250 kW I/O Cabinet

- GVX500K500NHS: Galaxy VX 500 kW, 400 V, start-up 5x8
- GVX500K750NHS: Galaxy VX 500 kW scalable to 750 kW 400 V, start-up 5x8
- GVX500K1000NHS: Galaxy VX 500 kW scalable to 1000 kW 400 V, start-up 5x8
- GVX500K1250NHS: Galaxy VX 500 kW scalable to 1250 kW 400 V, start-up 5x8
- GVX625K625NHS: Galaxy VX 625 kW, 400 V, start-up 5x8
- GVX625K1000NHS: Galaxy VX 625 kW scalable to 1000 kW 400 V, start-up 5x8
- GVX750K500NHS: Galaxy VX 500 kW N+1 redundant UPS 400 V, start-up 5x8
- GVX750K750NHS: Galaxy VX 750 kW, 400V, start-up 5x8
- GVX750K1000NHS: Galaxy VX 750 kW scalable to 1000 kW 400 V, start-up 5x8
- GVX750K1250NHS: Galaxy VX 750 kW scalable to 1250 kW 400 V, start-up 5x8
- GVX800K800NHS: Galaxy VX 800 kW, 400 V, start-up 5x8
- GVX1000K750NHS: Galaxy VX 750 kW N+1 redundant UPS 400 V, start-up 5x8
- GVX1000K1000NHS: Galaxy VX 1000 kW, 400 V, start-up 5x8
- GVX1000K1250NHS: Galaxy VX 1000 kW scalable to 1250 kW 400 V, start-up 5x8
- GVX1100K1100NHS: Galaxy VX 1100 kW, 400 V, start-up 5x8
- GVX1250K1000NHS: Galaxy VX 1000 kW N+1 Redundant UPS 400 V, Start-up 5x8
- GVX1250K1250NHS: Galaxy VX 1250 kW, 400 V, Start-up 5x8
- GVX1500K1100NHS: Galaxy VX 1100 kW N+1 Redundant UPS 400 V, Start up 5x8
- GVX1500K1250NHS: Galaxy VX 1250 kW N+1 Redundant UPS 400 V, Start-up 5x8

UPSs with 1500 kW I/O Cabinet

- GVX500K1500HS: Galaxy VX 500 kW 400 V scalable to 1500 kW, start-up 5x8
- GVX750K1500HS: Galaxy VX 750 kW 400 V scalable to 1500 kW, start-up 5x8
- GVX1000K1500HS: Galaxy VX 1000 kW 400 V scalable to 1500 kW, start-up 5x8
- GVX1250K1500HS: Galaxy VX 1250 kW 400 V scalable to 1500 kW, start-up 5x8
- GVX1500K1500HS: Galaxy VX 1500 kW 400 V, start-up 5x8
- GVX1750K1500HS: Galaxy VX 1500 kW 400 V N+1 redundant UPS, start-up 5x8

Overview of Configurations

Breakers in the System

UIB	Unit input breaker
SSIB	Static switch input breaker
BB	Battery breaker
MBB	Maintenance bypass breaker
UOB	Unit output breaker
BF2	Backfeed protection switch

Overview of UPSs with 1250 kW I/O Cabinet - Single Utility/Mains

The illustration shows a 750 kW UPS. The principle is the same for the other UPSs with the 1250 kW I/O cabinet.

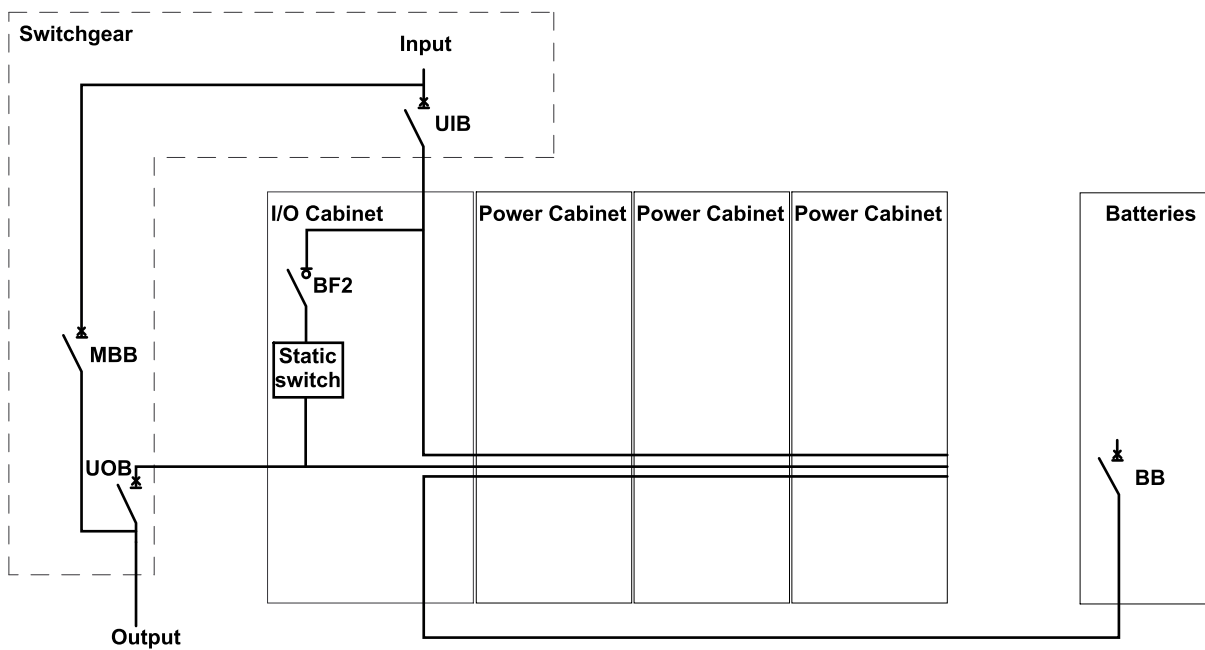

Overview of UPSs with 1250 kW I/O Cabinet - Dual Utility/Mains

The illustration shows a 750 kW UPS. The principle is the same for the other UPSs with the 1250 kW I/O cabinet.

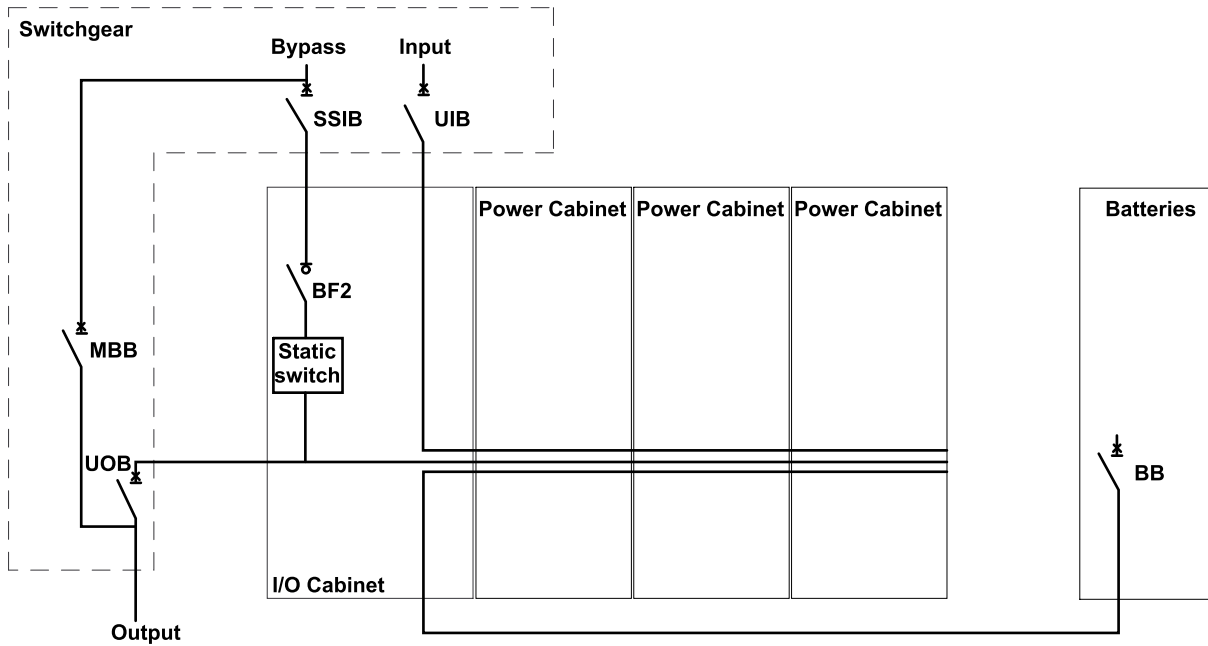

Overview of UPSs with 1500 kW I/O Cabinet – Single Utility/Mains

The illustration shows a 1500 kW UPS. The principle is the same for the other UPSs with the 1500 kW I/O cabinet.

Galaxy VX 1500 kW UPS

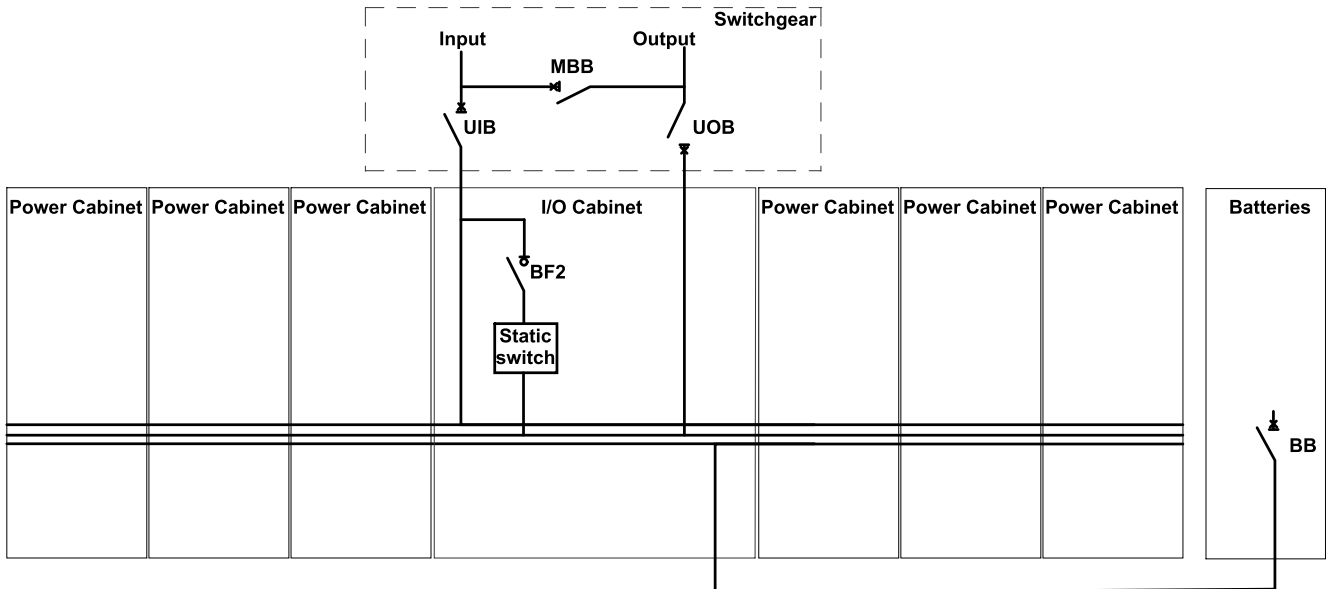

Overview of UPSs with 1500 kW I/O Cabinet – Dual Utility/Mains

The illustration shows a 1500 kW UPS. The principle is the same for the other UPSs with the 1500 kW I/O cabinet.

Galaxy VX 1500 kW UPS

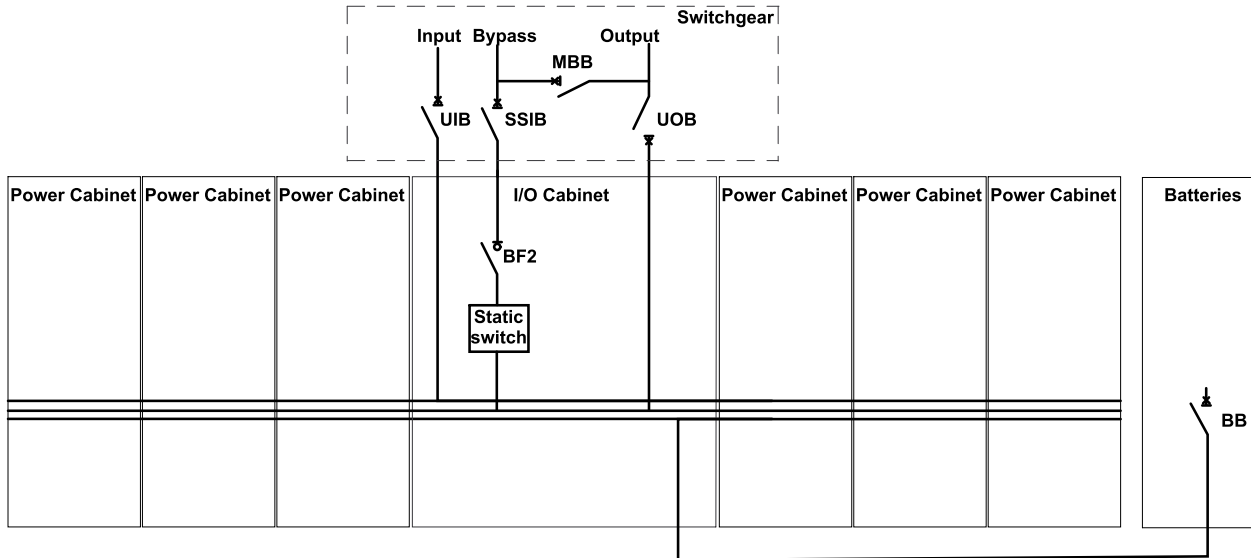

Input Power Factor

	500 kW				625 kW			
Voltage (V)	380	400	415	440 V	380	400	415	440 V
25% load	0.98	0.98	0.98	0.98	0.98	0.98	0.98	0.98
50% load	0.99	0.99	0.99	0.99	0.99	0.99	0.99	0.99
75% load	0.99	0.99	0.99	0.99	0.99	0.99	0.99	0.99
100% load	1.00	1.00	1.00	1.00	1.00	1.00	1.00	1.00

	750 kW				800 kW			
Voltage (V)	380	400	415	440 V	380	400	415	440 V
25% load	0.98	0.98	0.98	0.98	0.98	0.98	0.98	0.98
50% load	0.99	0.99	0.99	0.99	0.99	0.99	0.99	0.99
75% load	0.99	0.99	0.99	0.99	0.99	0.99	0.99	0.99
100% load	1.00	1.00	1.00	1.00	1.00	1.00	1.00	1.00

	1000 kW				1100 kW			
Voltage (V)	380	400	415	440 V	380	400	415	440 V
25% load	0.98	0.98	0.98	0.98	0.98	0.98	0.98	0.98
50% load	0.99	0.99	0.99	0.99	0.99	0.99	0.99	0.99
75% load	0.99	0.99	0.99	0.99	0.99	0.99	0.99	0.99
100% load	1.00	1.00	1.00	1.00	1.00	1.00	1.00	1.00

	1250 kW				1500 kW			
Voltage (V)	380	400	415	440 V	380	400	415	440 V
25% load	0.98	0.98	0.98	0.98	0.98	0.98	0.98	0.98
50% load	0.99	0.99	0.99	0.99	0.99	0.99	0.99	0.99
75% load	0.99	0.99	0.99	0.99	0.99	0.99	0.99	0.99
100% load	1.00	1.00	1.00	1.00	1.00	1.00	1.00	1.00

Input Voltage Window

Mains Voltage at 380 V Nominal

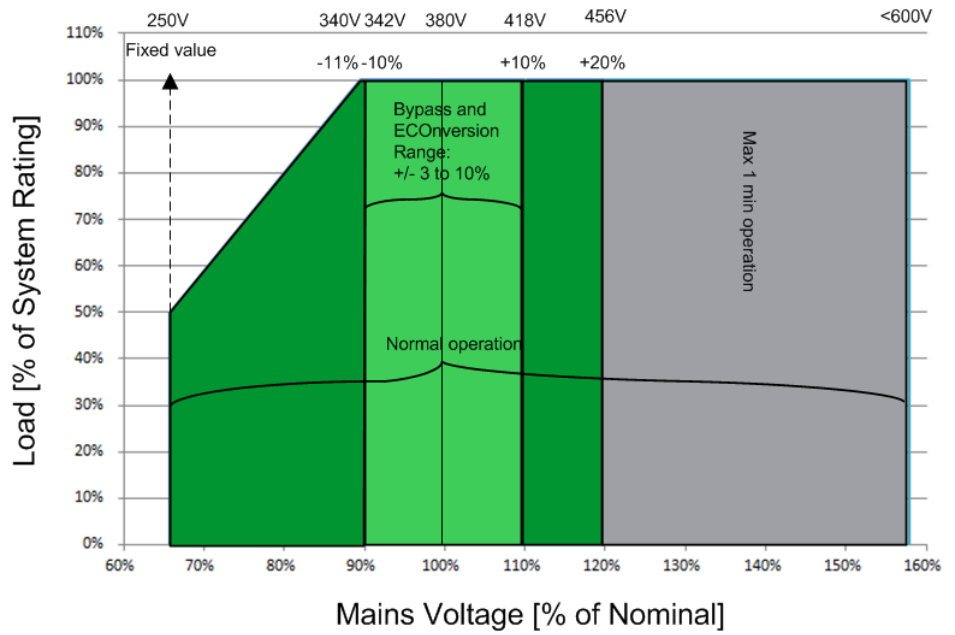

Mains Voltage at 400 V Nominal

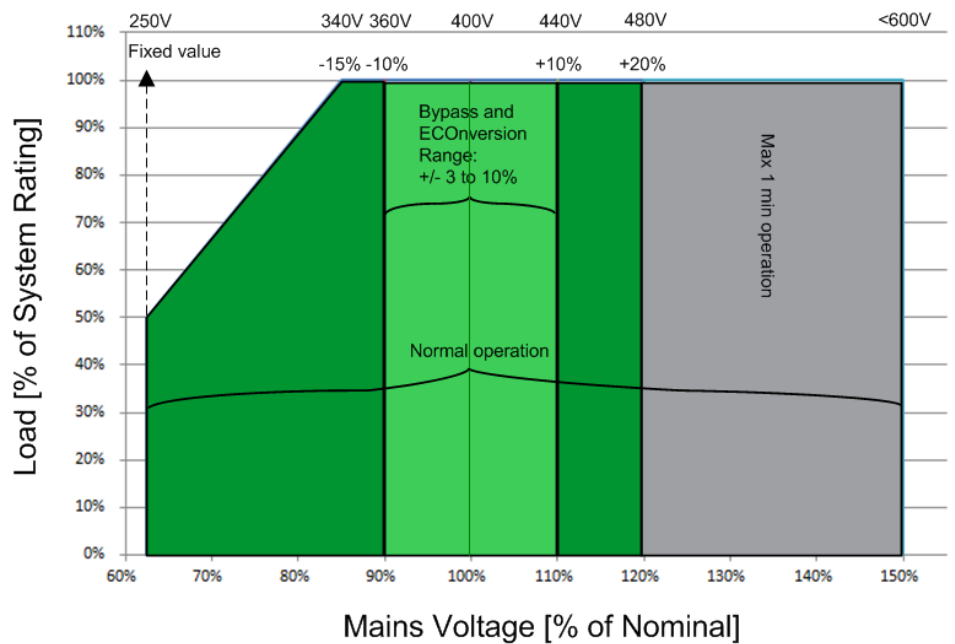

Mains Voltage at 415 V Nominal

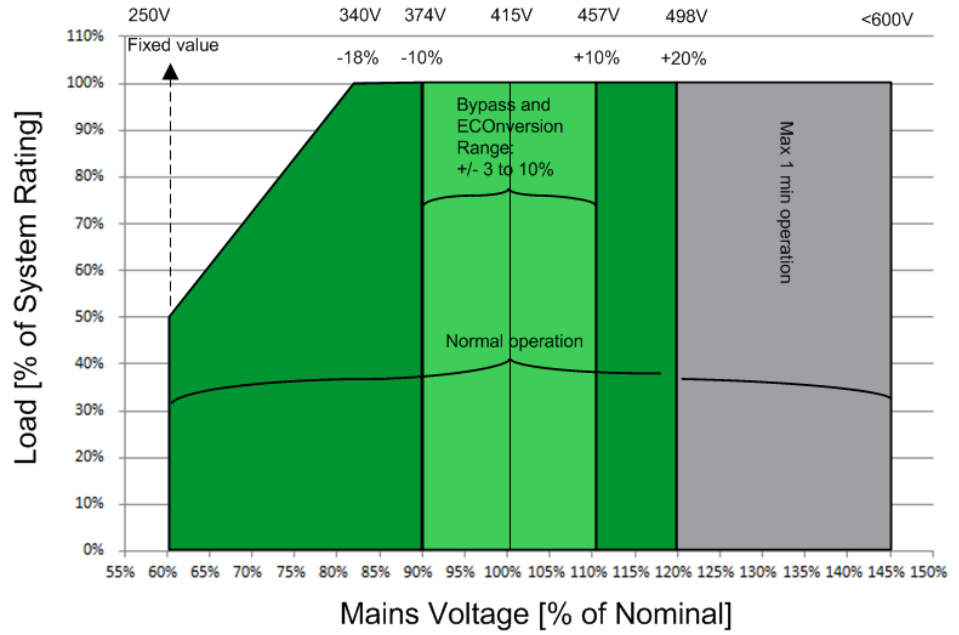

Mains Voltage at 440 V Nominal

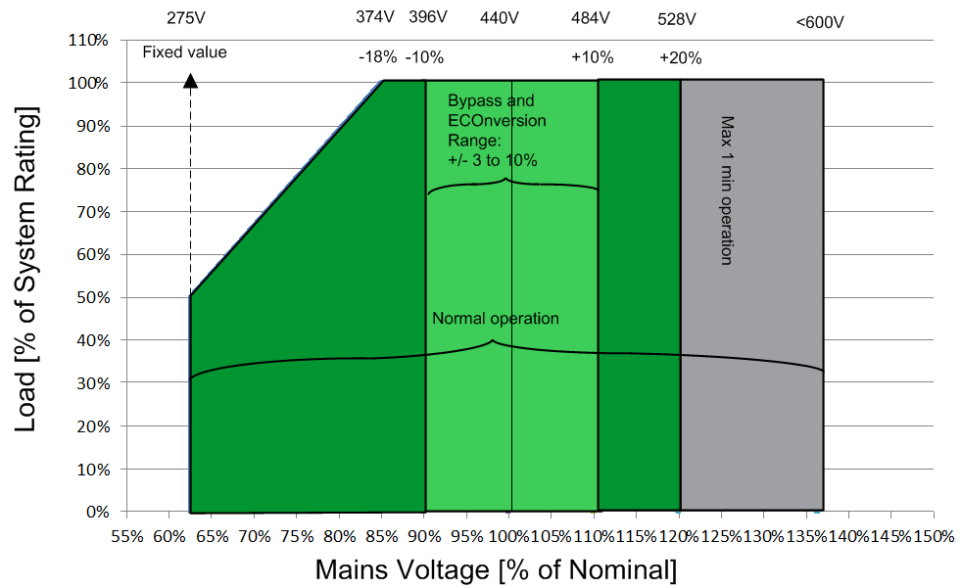

Inverter Short-Circuit Capabilities (Bypass not Available)

IK1 – Short-Circuit between a Phase and Neutral

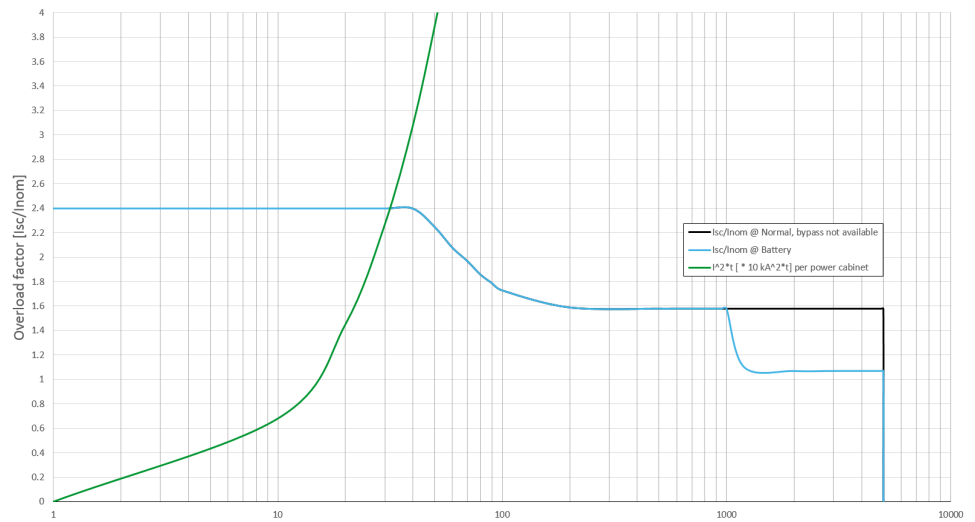

IK2 – Short-Circuit between Two Phases

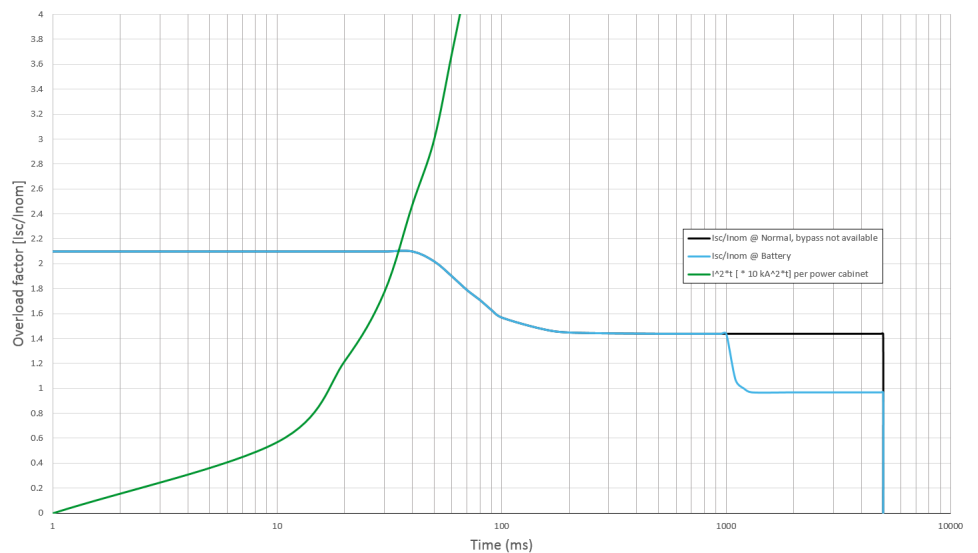

IK3 – Short-Circuit between All Three Phases

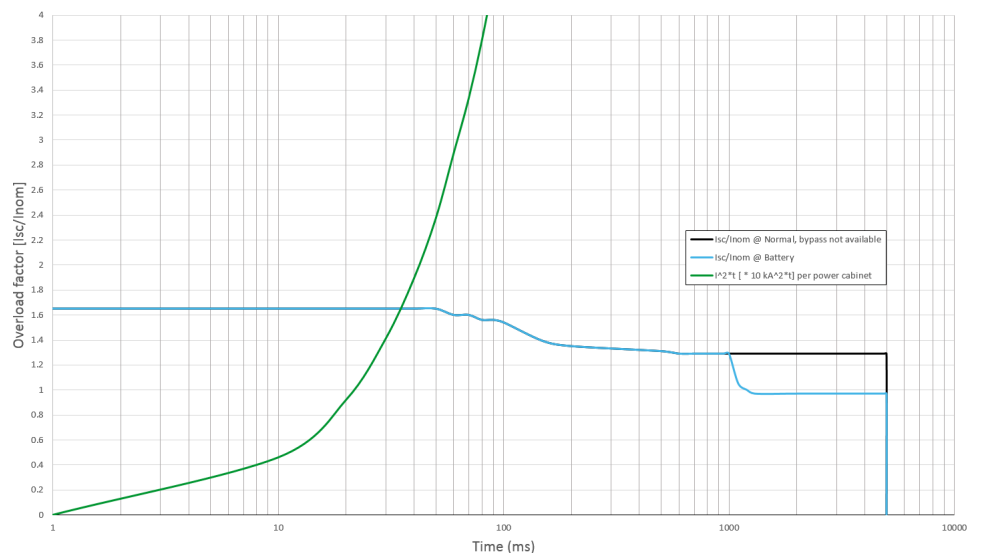

Efficiency for UPSs with 1250 kW I/O Cabinet

Efficiency for a 500 kW UPS

Voltage (V)	Normal operation				ECO mode			
	380	400	415	440 V	380	400	415	440 V
25% load	96.0%	95.2%	95.2%	95.2%	97.4%	96.2%	96.3%	96.8%
50% load	96.1%	95.7%	95.7%	95.8%	99.0%	98.7%	98.8%	98.6%
75% load	95.8%	95.6%	95.6%	95.8%	99.0%	98.8%	98.8%	98.8%
100% load	95.6%	95.5%	95.6%	95.8%	99.2%	99.0%	99.0%	99.0%

Voltage (V)	ECOversion				Battery operation			
	380	400	415	440 V	380	400	415	440 V
25% load	99.0%	98.3%	98.4%	97.7%	96.7%	96.5%	96.6%	96.6%
50% load	98.4%	98.5%	98.1%	98.2%	96.7%	96.7%	96.5%	96.5%
75% load	99.0%	98.9%	98.9%	98.8%	94.4%	96.4%	96.3%	96.3%
100% load	99.0%	99.2%	99.2%	99.1%	96.0%	95.8%	95.5%	95.5%

Efficiency for a 625 kW UPS

Voltage (V)	Normal operation				ECO mode			
	380	400	415	440 V	380	400	415	440 V
25% load	95.1%	95.2%	95.2%	95.2%	98.0%	97.6%	97.5%	97.5%
50% load	95.7%	95.7%	95.7%	96.0%	98.9%	98.7%	98.6%	98.6%
75% load	95.6%	95.6%	95.6%	96.0%	99.0%	98.8%	98.8%	98.8%
100% load	94.9%	95.5%	95.6%	95.9%	98.9%	98.8%	98.8%	98.9%

Voltage (V)	ECOversion				Battery operation			
	380	400	415	440 V	380	400	415	440 V
25% load	97.1%	97.1%	98.0%	97.6%	96.9%	96.9%	96.6%	96.6%
50% load	98.4%	98.4%	98.4%	98.4%	96.3%	96.4%	96.5%	96.5%
75% load	98.7%	98.7%	98.7%	98.7%	96.3%	96.3%	96.3%	96.3%
100% load	98.8%	98.8%	98.8%	98.9%	96.1%	96.2%	95.5%	95.5%

Efficiency for a 750 kW UPS

Voltage (V)	Normal operation				ECO mode			
	380	400	415	440 V	380	400	415	440 V
25% load	95.7%	95.4%	95.4%	95.4%	98.4%	98.0%	97.9%	97.9%
50% load	95.8%	95.8%	95.9%	96.0%	98.9%	98.7%	98.6%	98.6%
75% load	95.3%	95.4%	95.7%	95.9%	99.0%	98.8%	98.8%	98.8%
100% load	94.6%	94.9%	95.2%	95.5%	99.0%	98.9%	98.9%	98.9%

	ECOversion				Battery operation			
Voltage (V)	380	400	415	440 V	380	400	415	440 V
25% load	97.7%	97.7%	98.6%	98.2%	96.7%	96.7%	96.6%	96.6%
50% load	98.5%	98.5%	98.5%	98.5%	96.6%	96.7%	96.6%	96.6%
75% load	98.7%	98.7%	98.7%	98.7%	96.1%	96.2%	96.2%	96.2%
100% load	98.8%	98.8%	98.8%	98.9%	95.7%	95.8%	95.8%	95.8%

Efficiency for a 800 kW UPS

	Normal operation				ECO mode			
Voltage (V)	380	400	415	440 V	380	400	415	440 V
25% load	95.1%	95.1%	95.2%	95.2%	97.8%	97.8%	98.7%	98.7%
50% load	95.8%	95.9%	96.0%	96.1%	98.6%	98.6%	98.9%	98.9%
75% load	95.7%	95.8%	96.0%	96.1%	98.9%	98.9%	98.9%	98.9%
100% load	95.4%	95.5%	95.8%	96.1%	98.9%	99.0%	99.0%	99.0%

	ECOversion				Battery operation			
Voltage (V)	380	400	415	440 V	380	400	415	440 V
25% load	97.5%	97.4%	97.5%	97.5%	96.2%	96.9%	97.0%	97.0%
50% load	98.5%	98.5%	98.5%	98.5%	96.4%	96.9%	96.6%	96.6%
75% load	98.8%	98.8%	98.8%	98.8%	96.3%	96.9%	96.8%	96.8%
100% load	98.9%	98.9%	99.0%	99.1%	96.0%	96.4%	96.3%	96.3%

Efficiency for a 1000 kW UPS

	Normal operation				ECO mode			
Voltage (V)	380	400	415	440 V	380	400	415	440 V
25% load	95.9%	95.6%	95.6%	95.6%	98.6%	98.2%	98.1%	98.1%
50% load	96.0%	96.0%	96.1%	96.1%	99.1%	98.9%	98.8%	98.8%
75% load	95.5%	95.6%	95.9%	95.9%	99.2%	99.0%	99.0%	99.0%
100% load	94.8%	95.1%	95.4%	95.4%	99.2%	99.1%	99.1%	99.1%

	ECOversion				Battery operation			
Voltage (V)	380	400	415	440 V	380	400	415	440 V
25% load	97.9%	97.9%	98.8%	98.4%	96.8%	96.8%	96.7%	96.7%
50% load	98.7%	98.7%	98.7%	98.7%	96.7%	96.8%	96.7%	96.7%
75% load	98.9%	98.9%	98.9%	98.9%	96.2%	96.3%	96.3%	96.3%
100% load	99.0%	99.0%	99.0%	99.1%	95.8%	95.9%	95.9%	95.9%

Efficiency for a 1100 kW UPS

Voltage (V)	Normal operation				ECO mode			
	380	400	415	440 V	380	400	415	440 V
25% load	95.6%	95.6%	95.7%	95.6%	98.1%	98.2%	98.2%	0.0%
50% load	95.8%	96.0%	96.1%	96.1%	98.8%	98.8%	98.8%	0.0%
75% load	95.5%	95.8%	95.9%	95.9%	99.0%	99.1%	99.1%	0.0%
100% load	94.9%	95.3%	95.4%	95.4%	99.0%	99.0%	99.0%	99.1%

Voltage (V)	ECOConversion				Battery operation			
	380	400	415	440 V	380	400	415	440 V
25% load	97.8%	97.8%	97.9%	98.1%	96.4%	96.2%	96.3%	96.7%
50% load	98.7%	98.8%	98.7%	98.8%	96.6%	96.6%	96.4%	96.7%
75% load	98.8%	98.8%	98.8%	99.0%	94.5%	96.5%	96.4%	96.3%
100% load	98.6%	98.9%	98.9%	99.1%	96.0%	95.8%	95.5%	95.9%

Efficiency for a 1250 kW UPS

Voltage (V)	Normal operation				ECO mode			
	380	400	415	440 V	380	400	415	440 V
25% load	95.6%	95.6%	95.7%	95.7%	98.1%	98.2%	98.2%	98.3%
50% load	95.8%	96.0%	96.1%	96.3%	98.8%	98.8%	98.8%	98.9%
75% load	95.4%	95.7%	95.8%	96.0%	98.9%	99.0%	99.0%	99.1%
100% load	94.8%	95.2%	95.3%	95.7%	99.0%	99.0%	99.0%	99.1%

Voltage (V)	ECOConversion				Battery operation			
	380	400	415	440 V	380	400	415	440 V
25% load	97.9%	97.9%	98.0%	98.0%	96.7%	96.5%	96.6%	96.6%
50% load	98.7%	98.8%	98.7%	98.7%	96.7%	96.7%	96.5%	96.5%
75% load	98.9%	98.9%	98.9%	99.0%	96.4%	96.4%	96.3%	96.3%
100% load	98.7%	99.0%	99.0%	99.1%	96.0%	95.8%	95.5%	95.5%

Efficiency for UPSs with 1500 kW I/O Cabinet

Efficiency for a 500 kW UPS

Voltage (V)	Normal operation				ECO mode			
	380	400	415	440 V	380	400	415	440 V
25% load	96.1%	96.3%	96.3%	96.3%	98.7%	98.7%	98.7%	98.6%
50% load	96.3%	96.5%	96.5%	96.5%	99.1%	99.1%	99.1%	99.1%
75% load	96.0%	96.2%	96.2%	96.2%	99.1%	99.1%	99.1%	99.2%
100% load	95.2%	95.4%	95.4%	95.8%	99.2%	99.2%	99.2%	99.2%

	ECOversion				Battery operation			
Voltage (V)	380	400	415	440 V	380	400	415	440 V
25% load	98.5%	98.5%	98.5%	98.4%	95.9%	95.9%	95.9%	95.9%
50% load	99.1%	99.1%	99.1%	99.1%	96.4%	96.4%	96.4%	96.4%
75% load	99.1%	99.1%	99.1%	99.2%	96.0%	96.0%	96.0%	96.0%
100% load	99.1%	99.2%	99.2%	99.2%	95.6%	95.6%	95.6%	95.6%

Efficiency for a 750 kW UPS

	Normal operation				ECO mode			
Voltage (V)	380	400	415	440 V	380	400	415	440 V
25% load	96.0%	96.2%	96.2%	96.2%	98.6%	98.6%	98.6%	98.6%
50% load	96.1%	96.3%	96.3%	96.4%	99.0%	99.0%	99.0%	99.1%
75% load	95.7%	95.9%	95.9%	96.1%	99.1%	99.1%	99.1%	99.2%
100% load	95.0%	95.2%	95.2%	95.6%	99.1%	99.1%	99.1%	99.2%

	ECOversion				Battery operation			
Voltage (V)	380	400	415	440 V	380	400	415	440 V
25% load	98.5%	98.5%	98.5%	98.4%	95.9%	95.9%	95.9%	95.9%
50% load	99.0%	99.0%	99.0%	99.0%	96.4%	96.4%	96.4%	96.4%
75% load	99.1%	99.1%	99.1%	99.2%	96.0%	96.0%	96.0%	96.0%
100% load	99.1%	99.1%	99.1%	99.2%	95.6%	95.6%	95.6%	95.6%

Efficiency for a 1000 kW UPS

	Normal operation				ECO mode			
Voltage (V)	380	400	415	440 V	380	400	415	440 V
25% load	95.9%	96.1%	96.1%	96.2%	98.6%	98.6%	98.6%	98.6%
50% load	96.0%	96.2%	96.2%	96.6%	99.0%	99.0%	99.0%	99.1%
75% load	95.4%	95.6%	95.6%	96.3%	99.1%	99.1%	99.1%	99.2%
100% load	94.8%	95.0%	95.0%	95.8%	99.1%	99.1%	99.1%	99.2%

	ECOversion				Battery operation			
Voltage (V)	380	400	415	440 V	380	400	415	440 V
25% load	98.5%	98.5%	98.5%	98.3%	95.9%	96.0%	95.9%	95.9%
50% load	99.0%	99.0%	99.0%	99.0%	96.4%	96.4%	96.4%	96.4%
75% load	99.1%	99.1%	99.1%	99.1%	96.0%	96.1%	96.0%	96.0%
100% load	99.1%	99.1%	99.1%	99.1%	95.6%	95.6%	95.6%	95.6%

Efficiency for a 1250 kW UPS

Voltage (V)	Normal operation				ECO mode			
	380	400	415	440 V	380	400	415	440 V
25% load	96.0%	96.2%	96.2%	96.2%	98.8%	98.8%	98.8%	98.8%
50% load	96.1%	96.3%	96.3%	96.5%	99.1%	99.1%	99.1%	99.2%
75% load	95.6%	95.8%	95.8%	96.1%	99.2%	99.2%	99.2%	99.3%
100% load	95.0%	95.2%	95.2%	95.6%	99.3%	99.3%	99.3%	99.3%

Voltage (V)	ECOversion				Battery operation			
	380	400	415	440 V	380	400	415	440 V
25% load	98.6%	98.6%	98.6%	98.4%	95.9%	95.9%	95.9%	95.9%
50% load	99.1%	99.1%	99.1%	99.1%	96.4%	96.4%	96.4%	96.4%
75% load	99.2%	99.2%	99.2%	99.2%	96.0%	96.0%	96.0%	96.0%
100% load	99.2%	99.2%	99.2%	99.2%	95.6%	95.6%	95.6%	95.6%

Efficiency for a 1500 kW UPS

Voltage (V)	Normal operation				ECO mode			
	380	400	415	440 V	380	400	415	440 V
25% load	96.0%	96.2%	96.2%	96.2%	98.8%	98.8%	98.8%	98.8%
50% load	96.1%	96.3%	96.3%	96.6%	99.1%	99.1%	99.1%	99.2%
75% load	95.6%	95.8%	95.8%	96.2%	99.2%	99.2%	99.2%	99.3%
100% load	95.0%	95.2%	95.2%	95.6%	99.3%	99.3%	99.3%	99.3%

Voltage (V)	ECOversion				Battery operation			
	380	400	415	440 V	380	400	415	440 V
25% load	98.6%	98.6%	98.6%	98.7%	95.9%	96.1%	95.9%	95.9%
50% load	99.1%	99.1%	99.1%	99.2%	96.4%	96.4%	96.4%	96.4%
75% load	99.2%	99.2%	99.2%	99.3%	96.0%	96.0%	96.0%	96.0%
100% load	99.2%	99.2%	99.2%	99.3%	95.6%	95.6%	95.6%	95.6%

Derating Due to Load Power Factor

0.7 leading to 0.5 lagging without derating.

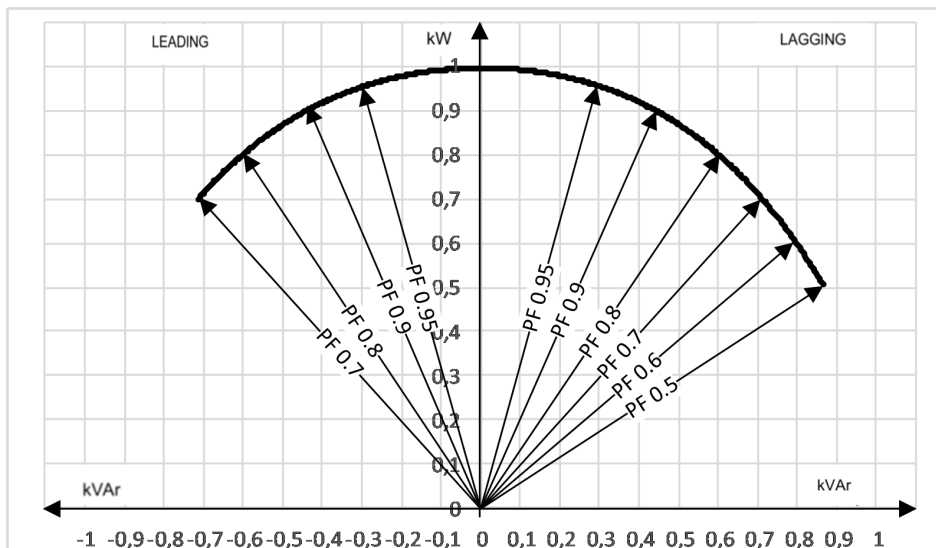

Batteries

Battery Runtimes for Li-Ion Battery Cabinets LIBATTSMGGIEC

NOTE: Please allow for a tolerance of $\pm 10\%$ at the beginning of life.

The estimated battery runtimes are based on an environment with an ambient temperature of 23 °C (75 °F).

500 kW UPS

Number of LIBATTSMGGIEC cabinets	3	4	5	6	7	8	9	10	11	12
25% load	46:30	62:30	78:30	94:30	110:00	125:00	140:00	155:00	170:00	185:00
50% load	23:00	31:00	39:00	47:00	55:00	63:00	71:00	79:00	87:00	95:00
75% load	14:30	20:00	25:30	31:00	36:00	41:30	47:00	52:00	57:30	63:00
100% load	10:30	14:30	18:30	22:30	27:00	31:00	35:00	39:00	43:00	46:30

625 kW UPS

Number of LIBATTSMGGIEC cabinets	3	4	5	6	7	8	9	10	11	12
25% load	37:00	49:30	62:30	75:00	88:00	100:00	110:00	125:00	135:00	150:00
50% load	18:00	24:30	31:00	37:30	43:30	50:00	56:30	63:00	69:30	76:00
75% load	11:30	16:00	20:00	24:30	29:00	33:00	37:30	41:30	46:00	50:00
100% load	5:05 ¹	11:30	14:30	18:00	21:00	24:30	27:30	31:00	34:00	37:00

750 kW UPS

Number of LIBATTSMGGIEC cabinets	4	5	6	7	8	9	10	11	12
25% load	41:30	52:00	63:00	73:30	84:00	94:30	105:00	115:00	125:00
50% load	20:00	25:30	31:00	36:30	41:30	47:00	52:30	57:30	63:00
75% load	13:00	16:30	20:00	23:30	27:30	31:00	34:30	38:00	41:30
100% load	9:30 ¹	12:00	14:30	17:30	20:00	22:30	25:30	28:00	31:00

1. Only partial discharge

800 kW UPS

Number of LIBATTSMGGIEC cabinets	4	5	6	7	8	9	10	11	12
25% load	39:00	49:00	59:00	69:00	79:00	88:30	98:30	105:00	115:00
50% load	19:00	24:00	29:00	34:00	39:00	44:00	49:00	54:30	59:30
75% load	12:00	15:30	19:00	22:00	25:30	29:00	32:30	35:30	39:00
100% load	7:45 ²	11:00	14:00	16:30	19:00	21:30	24:00	26:30	29:00

1000 kW UPS

Number of LIBATTSMGGIEC cabinets	5	6	7	8	9	10	11	12
25% load	39:00	47:00	55:00	63:00	71:00	79:00	87:00	95:00
50% load	19:00	23:00	27:00	31:00	35:00	39:00	43:00	47:00
75% load	12:00	15:00	17:30	20:00	23:00	25:30	28:00	31:00
100% load	7:35 ²	10:30	12:30	14:30	16:30	18:30	20:30	22:30

1100 kW UPS

Number of LIBATTSMGGIEC cabinets	5	6	7	8	9	10	11	12
25% load	35:00	42:30	50:00	57:00	64:30	71:30	79:00	86:00
50% load	17:00	21:00	24:30	28:00	32:00	35:30	39:00	43:00
75% load	11:00	13:30	16:00	18:00	20:30	23:00	25:30	28:00
100% load	1:00 ²	9:50 ²	11:30	13:30	15:00	17:00	19:00	20:30

1250 kW UPS

Number of LIBATTSMGGIEC cabinets	6	7	8	9	10	11	12
25% load	37:30	43:30	50:00	56:30	63:00	69:30	76:00
50% load	18:00	21:30	24:30	28:00	31:00	34:00	37:30
75% load	11:30	13:30	16:00	18:00	20:00	22:30	24:30
100% load	5:05 ²	10:00	11:30	13:00	14:30	16:30	18:00

1500 kW UPS

Number of LIBATTSMGGIEC cabinets	7	8	9	10	11	12	13
25% load	36:30	41:30	47:00	52:30	57:30	63:00	68:30
50% load	17:30	20:00	23:00	25:30	28:30	31:00	33:30
75% load	11:00	13:00	14:30	16:30	18:30	20:00	22:00
100% load	2:25 ²	9:30 ²	10:30	12:00	13:30	14:30	16:00

2. Only partial discharge

1500 kW UPS

Number of LIBATTSMGGIEC cabinets	14	15	16	17	18	19	20
25% load	73:30	79:00	84:00	89:30	94:30	100:00	105:00
50% load	36:30	39:00	41:30	44:30	47:00	49:30	52:30
75% load	23:30	25:30	27:00	29:00	30:30	32:30	34:30
100% load	17:30	18:30	20:00	21:30	22:30	24:00	25:30

End of Discharge Voltage

The voltage is 1.6 to 1.75 per cell depending on discharge ratio.

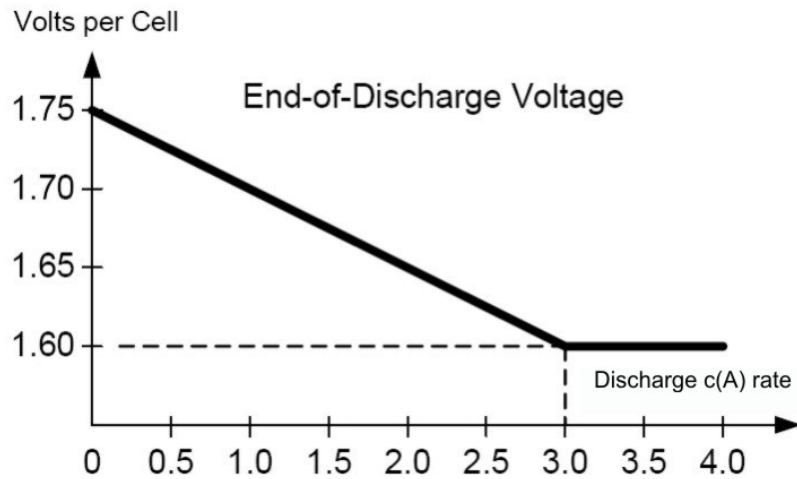

Battery Voltage Range

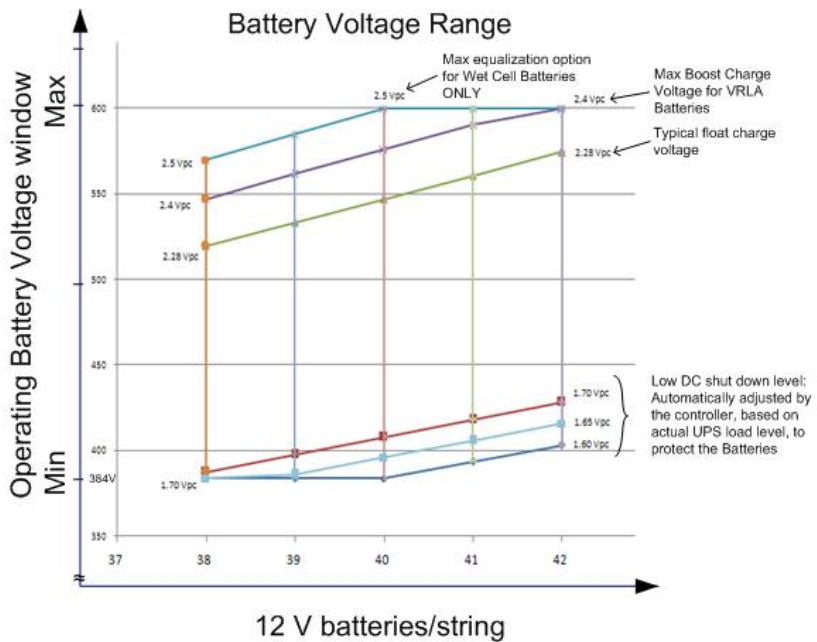

Compliance

Safety	IEC 62040-1: 2008-06, 1st edition Uninterruptible Power Systems (UPS) - Part 1: General and safety requirements for UPS EN 62040-1: 2013-01, 1st edition amendment 1
EMC/EMI/RFI	IEC 62040-2: 2005-10, 2nd edition Uninterruptible Power Systems (UPS) - Part 2: Electromagnetic compatibility (EMC) requirements
Performance	IEC 62040-3: 2011-03, 2nd edition Uninterruptible Power Systems (UPS) - Part 3: Method of specifying the performance and test requirements
Environmental	IEC 62040-4: 2013-04, 1st edition Uninterruptible Power Systems (UPS) - Part 4: Environmental aspects – Requirements and reporting
Markings	CE, C-Tick
Transportation	ISTA 2B
Seismic	OSHPD, IBC2012 and CBC2013 to $S_{DS} = 1.83\text{ g}$

Communication and Management

Local Area Network	100 Mbps
Extensions	Two optional Network Management Cards
MODBUS	MODBUS TCP/IP
Output relays	6 configurable
Input dry contacts	5 configurable
Standard control panel	7-inch touchscreen display
Audible alarm	Yes
Emergency Power Off (EPO)	Options: <ul style="list-style-type: none"> • Normally Open (NO) • Normally Closed (NC) • External 24 VDC SELV
External synchronization	Yes
Battery monitoring	Yes — string level monitoring

EPO Connections

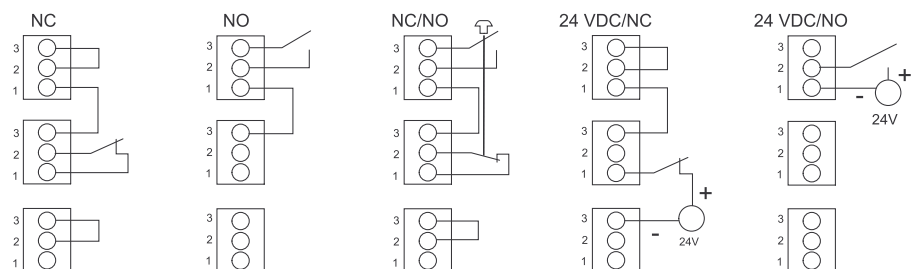

Overview of Input Contacts and Output Relays

Input Contacts

Do not connect any circuit to the input contacts unless it can be confirmed that the circuit is Class 2/SELV.

All circuits connected must have the same 0 V reference.

The switch SW5500 on 0P6548 is used to select between internal SELV supply for inputs (standard setting) and external supply³. If external supply is selected, the supply must be connected to J5530.

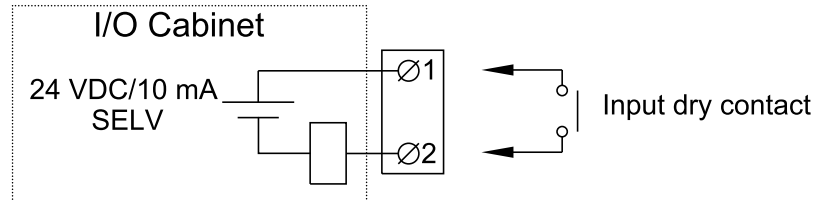

Name	Description	Location
IN 1 (Contact 1)	Configurable input contact	0P6548 terminal J5502 ⁴
IN 2 (Contact 2)	Configurable input contact	0P6548 terminal J5503 ⁴
IN 3 (Contact 3)	Configurable input contact	0P6548 terminal J5504 ⁴
IN 4 (Contact 4)	Configurable input contact	0P6548 terminal J5505 ⁴
IN 5 (Contact 5)	Configurable input contact	0P6548 terminal J5510 ⁴
IN 6	UOB redundant AUX contact	0P6548 terminal J5509 ⁴
IN 7	Transformer temperature switch	0P6548 terminal J5508 ⁴
IN 8	External bonding contact	0P6548 terminal J5507 ⁴
IN 9	Forced external synchronization input	0P6548 terminal J5506 ⁴
IN 10	External synchronization requested	0P6548 terminal J5511 ⁴
IN 11	Use static bypass standby	0P6548 terminal J5512 ⁴
IN 14	MegaTie	0P6552 terminal J9027 ⁴

Output Relays

NOTE: Maximum 250 VAC 5 A must be connected to the output relays.

All external circuitry must be fused with maximum 5 A fast acting fuses.

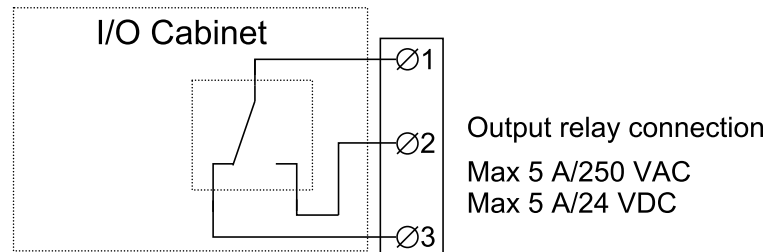

Name	Description	Location
OUT 1 (Relay 1)	Configurable output relay	0P6547 terminal J4939
OUT 2 (Relay 2)	Configurable output relay	0P6547 terminal J4940
OUT 3 (Relay 3)	Configurable output relay	0P6547 terminal J4941

3. An external supply is useful in parallel systems where inputs are connected between different UPSs. This is to have a common reference and to avoid cross currents.
 4. Class 2/SELV wiring

Name	Description	Location
OUT 4	Forced external synchronization output	0P6548 terminal J5520 ⁵
OUT 5	MegaTie	0P6548 terminal J5521 ⁵
OUT 6	External synchronization requested output	0P6548 terminal J5522 ⁵
OUT 7	UPS in inverter ON	0P6548 terminal J5523 ⁵
OUT 8 (Relay 4)	Configurable output relay	0P6548 terminal J5524 ⁵
OUT 9 (Relay 5)	Configurable output relay	0P6548 terminal J5525 ⁵
OUT 10 (Relay 6)	Configurable output relay	0P6548 terminal J5528 ⁵
OUT 14	Bonding contactor	0P6552 terminal J9029 ⁵

NOTE: Refer to the operation manual for configuration options.

Facility Planning

Specifications for 500 kW UPS

	Voltage (V)	380	400	415	440 V	480 V
Input Specifications	Connections	IEC: L1, L2, L3, PE ⁶ UL: L1, L2, L3 + G ⁷				
	Input voltage range (V) ⁸	340-456	340-480	353-498	374-528	408-576
	Frequency (Hz)	40-70				
	Nominal input current (A)	800	760	731	685	633
	Maximum input current (A) ⁹	886	851	819	767	728
	Input current limitation (A)	890			832	760
	Total harmonic distortion (THDI)	<3% at 100% load, <4% at 50% load, <9% at 25% load				
	Input power factor	0.99 at >40% load, 0.98 at >20% load, 0.97 at >10% load				
	Protection	Contactors				
	Ramp-in	Adaptive 1-300 seconds				
Bypass Specifications	Connections	IEC: L1, L2, L3, N, PE or L1, L2, L3, PE ¹⁰ UL: L1, L2, L3, G or L1, L2, L3, N, G				
	Bypass voltage range (V)	342-418	360-440	374-457	396-484	432-528
	Frequency (Hz)	50 or 60				
	Frequency range (Hz)	Programmable: ±0.1, ±3, ±10. Default is ±3				
	Nominal bypass current (A)	767	729	703	663	606
	Maximum short circuit rating	100 kA RMS (conditioned by an internal molded switch with 90 kA peak magnetic trip)				
	Thyristor I ² t (kA*s ²)	9680 (1250 kW I/O) 16245 (1500 kW I/O)				9165 (1250 kW I/O) 16245 (1500 kW I/O)
	BF2 magnetic trip	39 kA				
	Protection	Molded switch with trip for backfeed protection				

6. TN, TT, and IT power distribution systems are supported.
 7. WYE source – solid grounded and high resistance grounded sources are supported. Corner (line) grounding is not supported.
 8. The system can operate at 600 V for 1 minute.
 9. At nominal input voltage and full charge.
 10. TN, TT, and IT power distribution systems with no earthed line conductors are supported.

	Voltage (V)	380	400	415	440 V	480 V
Output Specifications	Connections	IEC: L1, L2, L3, N, PE or L1, L2, L3, PE UL: L1, L2, L3, G, GEC ¹¹ or L1, L2, L3, N, G				
	Overload capacity	Normal operation: 150% for 1 minute, 125% for 10 minutes Battery operation: 115% for 1 minute Bypass operation: 110% ¹² continuous, 100% for 60 milliseconds for systems with 1250 kW I/O cabinet and 100 milliseconds for systems with 1500 kW I/O cabinet				
	Output voltage tolerance	Balanced load: $\pm 1\%$, Unbalanced load: $\pm 3\%$				
	Dynamic load response	$\pm 5\%$ after 2 ms, $\pm 1\%$ after 50 ms				
	Output power factor	1				
	Nominal output current (A)	760	722	696	656	601
	Total harmonic distortion (THDU)	<2% at 100% linear load, <3% at 100% non-linear load				
	Output frequency (Hz)	50/60 (synchronized to bypass), 50/60 Hz $\pm 0.1\%$ (free-running)				
	Slew rate (Hz/sec)	Programmable: 0.25, 0.5, 1, 2, 4, 6				
	Output performance classification (according to IEC/ EN62040-3)	Double-conversion: VFI-SS-111				
	Load crest factor	Up to 3 (THDU < 5%)				
	Load power factor	0.7 leading to 0.5 lagging without derating				
Battery Specifications	Charging power in % of output power	35% at $\leq 80\%$ load, 12% at 100% load				40% at $\leq 80\%$ load, 15% at 100% load
	Maximum charging power (kW)	60 at 100% load, 175 at $<80\%$ load				75 at 100% load, 200 at 80% load
	Nominal battery voltage (VDC)	480				
	Nominal float voltage (VDC)	546				
	End of discharge voltage (full load) (VDC)	384				
	End of discharge voltage (no load) (VDC)	420				
	Battery current at full load and nominal battery voltage (A)	1090				
	Battery current at full load and minimum battery voltage (A)	1362				
	Maximum battery backup time	Unlimited				
	Temperature compensation (per cell)	-3.3 mV per $^{\circ}\text{C}$ for $T \geq 25^{\circ}\text{C}$, 0 mV per $^{\circ}\text{C}$ for $T < 25^{\circ}\text{C}$				
	Ripple current	< 5% C20 (5 minutes backup time)				
	Battery test	Manual/automatic (selectable)				
	Deep discharge protection	Yes				
Recharge according to battery temperature	Yes					

11. Per NEC 250.30.

12. 125% for 480 V.

Specifications for 625 kW UPS

	Voltage (V)	380	400	415	440 V	480 V
Input Specifications	Connections	IEC: L1, L2, L3, PE ¹³ UL: L1, L2, L3 + G ¹⁴				
	Input voltage range (V) ¹⁵	340-456	340-480	353-498	374-528	408-576
	Frequency (Hz)	40-70				
	Nominal input current (A)	1001	950	914	853	791
	Maximum input current (A) ¹⁶	1107	1063	1024	956	910
	Input current limitation (A)	1113			1040	950
	Total harmonic distortion (THDI)	<3% at 100% load, <4% at 50% load, <9% at 25% load				
	Input power factor	0.99 at >40% load, 0.98 at >20% load, 0.97 at >10% load				
	Protection	Contactors				
	Ramp-in	Adaptive 1-300 seconds				
Bypass Specifications	Connections	IEC: L1, L2, L3, N, PE or L1, L2, L3, PE ¹⁷ UL: L1, L2, L3, G or L1, L2, L3, N, G				
	Bypass voltage range (V)	342-418	360-440	374-457	396-484	432-528
	Frequency (Hz)	50 or 60				
	Frequency range (Hz)	Programmable: ±0.1, ±3, ±10. Default is ±3				
	Nominal bypass current (A)	959	911	878	828	757
	Maximum short circuit rating	100 kA RMS (conditioned by an internal molded switch with 90 kA peak magnetic trip)				
	Thyristor I ² t (kA*s ²)	9680 (1250 kW I/O)				9165 (1250 kW I/O)
	BF2 magnetic trip	39 kA				
	Protection	Molded switch with trip for backfeed protection				
Output Specifications	Connections	IEC: L1, L2, L3, N, PE or L1, L2, L3, PE UL: L1, L2, L3, G, GEC ¹⁸ or L1, L2, L3, N, G				
	Overload capacity	Normal operation: 150% for 1 minute, 125% for 10 minutes Battery operation: 115% for 1 minute Bypass operation: 110% ¹⁹ continuous, 1000% for 60 milliseconds for systems with 1250 kW I/O cabinet and 100 milliseconds for systems with 1500 kW I/O cabinet				
	Output voltage tolerance	Balanced load: ±1%, Unbalanced load: ±3%				
	Dynamic load response	±5% after 2 ms, ±1% after 50 ms				
	Output power factor	1				
	Nominal output current (A)	950	902	870	820	752
	Total harmonic distortion (THDU)	<2% at 100% linear load, <3% at 100% non-linear load				
	Output frequency (Hz)	50/60 (synchronized to bypass), 50/60 Hz ±0.1% (free-running)				
	Slew rate (Hz/sec)	Programmable: 0.25, 0.5, 1, 2, 4, 6				
	Output performance classification (according to IEC/ EN62040-3)	Double-conversion: VFI-SS-111				
	Load crest factor	Up to 3 (THDU < 5%)				
Load power factor	0.7 leading to 0.5 lagging without derating					

13. TN, TT, and IT power distribution systems are supported.

14. WYE source – solid grounded and high resistance grounded sources are supported. Corner (line) grounding is not supported.

15. The system can operate at 600 V for 1 minute.

16. At nominal input voltage and full charge.

17. TN, TT, and IT power distribution systems with no earthed line conductors are supported.

18. Per NEC 250.30.

19. 125% for 480 V.

	Voltage (V)	380	400	415	440 V	480 V
Battery Specifications	Charging power in % of output power	35% at ≤ 80% load, 12% at 100% load				40% at ≤ 80% load, 15% at 100% load
	Maximum charging power (kW)	75 at 100% load, 218.75 at <80% load				93.75 at 100% load, 250 at 80% load
	Nominal battery voltage (VDC)	480				
	Nominal float voltage (VDC)	546				
	End of discharge voltage (full load) (VDC)	384				
	End of discharge voltage (no load) (VDC)	420				
	Battery current at full load and nominal battery voltage (A)	1362				
	Battery current at full load and minimum battery voltage (A)	1703				
	Maximum battery backup time	Unlimited				
	Temperature compensation (per cell)	-3.3 mV per °C for T ≥ 25 °C, 0 mV per °C for T < 25 °C				
	Ripple current	< 5% C20 (5 minutes backup time)				
	Battery test	Manual/automatic (selectable)				
	Deep discharge protection	Yes				
	Recharge according to battery temperature	Yes				

Specifications for 750 kW UPS

	Voltage (V)	380	400	415	440 V	480 V
Input Specifications	Connections	IEC: L1, L2, L3, PE ²⁰ UL: L1, L2, L3 + G ²¹				
	Input voltage range (V) ²²	340-456	340-480	353-498	374-528	408-576
	Frequency (Hz)	40-70				
	Nominal input current (A)	1201	1139	1097	1029	950
	Maximum input current (A) ²³	1328	1276	1229	1153	1092
	Input current limitation (A)	1335			1248	1140
	Total harmonic distortion (THDI)	<3% at 100% load, <4% at 50% load, <9% at 25% load				
	Input power factor	0.99 at >40% load, 0.98 at >20% load, 0.97 at >10% load				
	Protection	Contactors				
	Ramp-in	Adaptive 1-300 seconds				
Bypass Specifications	Connections	IEC: L1, L2, L3, N, PE or L1, L2, L3, PE ²⁴ UL: L1, L2, L3, G or L1, L2, L3, N, G				
	Bypass voltage range (V)	342-418	360-440	374-457	396-484	432-528
	Frequency (Hz)	50 or 60				
	Frequency range (Hz)	Programmable: ±0.1, ±3, ±10. Default is ±3				
	Nominal bypass current (A)	1151	1093	1054	994	909
	Maximum short circuit rating	100 kA RMS (conditioned by an internal molded switch with 90 kA peak magnetic trip)				
	Thyristor I ² t (kA*s ²)	9680 (1250 kW I/O) 16245 (1500 kW I/O)				9165 (1250 kW I/O) 16245 (1500 kW I/O)
	BF2 magnetic trip	39 kA				
	Protection	Molded switch with trip for backfeed protection				
	Output Specifications	Connections	IEC: L1, L2, L3, N, PE or L1, L2, L3, PE UL: L1, L2, L3, G, GEC ²⁵ or L1, L2, L3, N, G			
Overload capacity		Normal operation: 150% for 1 minute, 125% for 10 minutes Battery operation: 115% for 1 minute Bypass operation: 110% ²⁶ continuous, 1000% for 60 milliseconds for systems with 1250 kW I/O cabinet and 100 milliseconds for systems with 1500 kW I/O cabinet				
Output voltage tolerance		Balanced load: ±1%, Unbalanced load: ±3%				
Dynamic load response		±5% after 2 ms, ±1% after 50 ms				
Output power factor		1				
Nominal output current (A)		1140	1083	1043	984	902
Total harmonic distortion (THDU)		<2% at 100% linear load, <3% at 100% non-linear load				
Output frequency (Hz)		50/60 (synchronized to bypass), 50/60 Hz ±0.1% (free-running)				
Slew rate (Hz/sec)		Programmable: 0.25, 0.5, 1, 2, 4, 6				
Output performance classification (according to IEC/ EN62040-3)		Double-conversion: VFI-SS-111				
Load crest factor	Up to 3 (THDU < 5%)					
Load power factor	0.7 leading to 0.5 lagging without derating					

20. TN, TT, and IT power distribution systems are supported.

21. WYE source – solid grounded and high resistance grounded sources are supported. Corner (line) grounding is not supported.

22. The system can operate at 600 V for 1 minute.

23. At nominal input voltage and full charge.

24. TN, TT, and IT power distribution systems with no earthed line conductors are supported.

25. Per NEC 250.30.

26. 125% for 480 V.

	Voltage (V)	380	400	415	440 V	480 V
Battery Specifications	Charging power in % of output power	35% at ≤ 80% load, 12% at 100% load				40% at ≤ 80% load, 15% at 100% load
	Maximum charging power (kW)	90 at 100% load, 262 at <80% load				112.5 at 100% load, 300 at 80% load
	Nominal battery voltage (VDC)	480				
	Nominal float voltage (VDC)	546				
	End of discharge voltage (full load) (VDC)	384				
	End of discharge voltage (no load) (VDC)	420				
	Battery current at full load and nominal battery voltage (A)	1634				
	Battery current at full load and minimum battery voltage (A)	2043				
	Maximum battery backup time	Unlimited				
	Temperature compensation (per cell)	-3.3 mV per °C for T ≥ 25 °C, 0 mV per °C for T < 25 °C				
	Ripple current	< 5% C20 (5 minutes backup time)				
	Battery test	Manual/automatic (selectable)				
	Deep discharge protection	Yes				
	Recharge according to battery temperature	Yes				

Specifications for 800 kW UPS

	Voltage (V)	380	400	415	440 V	480 V
Input Specifications	Connections	IEC: L1, L2, L3, PE ²⁷ UL: L1, L2, L3 + G ²⁸				
	Input voltage range (V) ²⁹	340-456	340-480	353-498	374-528	408-576
	Frequency (Hz)	40-70				
	Nominal input current (A)	1281	1215	1170	1098	1013
	Maximum input current (A) ³⁰	1417	1361	1311	1230	1165
	Input current limitation (A)	1424			1331	1216
	Total harmonic distortion (THDI)	<3% at 100% load, <4% at 50% load, <9% at 25% load				
	Input power factor	0.99 at >40% load, 0.98 at >20% load, 0.97 at >10% load				
	Protection	Contactors				
	Ramp-in	Adaptive 1-300 seconds				
Bypass Specifications	Connections	IEC: L1, L2, L3, N, PE or L1, L2, L3, PE ³¹ UL: L1, L2, L3, G or L1, L2, L3, N, G				
	Bypass voltage range (V)	342-418	360-440	374-457	396-484	432-528
	Frequency (Hz)	50 or 60				
	Frequency range (Hz)	Programmable: ±0.1, ±3, ±10. Default is ±3				
	Nominal bypass current (A)	1228	1166	1124	1060	969
	Maximum short circuit rating	100 kA RMS (conditioned by an internal molded switch with 90 kA peak magnetic trip)				
	Thyristor I ² t (kA*s ²)	9680 (1250 kW I/O)				9165 (1250 kW I/O)
	BF2 magnetic trip	39 kA				
	Protection	Molded switch with trip for backfeed protection				
Output Specifications	Connections	IEC: L1, L2, L3, N, PE or L1, L2, L3, PE UL: L1, L2, L3, G, GEC ³² or L1, L2, L3, N, G				
	Overload capacity	Normal operation: 150% for 1 minute, 125% for 10 minutes Battery operation: 115% for 1 minute Bypass operation: 110% ³³ continuous, 1000% for 60 milliseconds for systems with 1250 kW I/O cabinet and 100 milliseconds for systems with 1500 kW I/O cabinet				
	Output voltage tolerance	Balanced load: ±1%, Unbalanced load: ±3%				
	Dynamic load response	±5% after 2 ms, ±1% after 50 ms				
	Output power factor	1				
	Nominal output current (A)	1216	1155	1113	1050	962
	Total harmonic distortion (THDU)	<2% at 100% linear load, <3% at 100% non-linear load				
	Output frequency (Hz)	50/60 (synchronized to bypass), 50/60 Hz ±0.1% (free-running)				
	Slew rate (Hz/sec)	Programmable: 0.25, 0.5, 1, 2, 4, 6				
	Output performance classification (according to IEC/ EN62040-3)	Double-conversion: VFI-SS-111				
	Load crest factor	Up to 3 (THDU < 5%)				
Load power factor	0.7 leading to 0.5 lagging without derating					

27. TN, TT, and IT power distribution systems are supported.

28. WYE source – solid grounded and high resistance grounded sources are supported. Corner (line) grounding is not supported.

29. The system can operate at 600 V for 1 minute.

30. At nominal input voltage and full charge.

31. TN, TT, and IT power distribution systems with no earthed line conductors are supported.

32. Per NEC 250.30.

33. 125% for 480 V.

	Voltage (V)	380	400	415	440 V	480 V
Battery Specifications	Charging power in % of output power	35% at ≤ 80% load, 12% at 100% load				40% at ≤ 80% load, 15% at 100% load
	Maximum charging power (kW)	96 at 100% load, 280 at <80% load				120 at 100% load, 320 at 80% load
	Nominal battery voltage (VDC)	480				
	Nominal float voltage (VDC)	546				
	End of discharge voltage (full load) (VDC)	384				
	End of discharge voltage (no load) (VDC)	420				
	Battery current at full load and nominal battery voltage (A)	1743				
	Battery current at full load and minimum battery voltage (A)	2179				
	Maximum battery backup time	Unlimited				
	Temperature compensation (per cell)	-3.3 mV per °C for T ≥ 25 °C, 0 mV per °C for T < 25 °C				
	Ripple current	< 5% C20 (5 minutes backup time)				
	Battery test	Manual/automatic (selectable)				
	Deep discharge protection	Yes				
	Recharge according to battery temperature	Yes				

Specifications for 1000 kW UPS

	Voltage (V)	380	400	415	440 V	480 V
Input Specifications	Connections	IEC: L1, L2, L3, PE ³⁴ UL: L1, L2, L3 + G ³⁵				
	Input voltage range (V) ³⁶	340-456	340-480	353-498	374-528	408-576
	Frequency (Hz)	40-70				
	Nominal input current (A)	1601	1519	1463	1370	1266
	Maximum input current (A) ³⁷	1771	1702	1638	1534	1456
	Input current limitation (A)	1780			1664	1520
	Total harmonic distortion (THDI)	<3% at 100% load, <4% at 50% load, <9% at 25% load				
	Input power factor	0.99 at >40% load, 0.98 at >20% load, 0.97 at >10% load				
	Protection	Contactors				
	Ramp-in	Adaptive 1-300 seconds				
Bypass Specifications	Connections	IEC: L1, L2, L3, N, PE or L1, L2, L3, PE ³⁸ UL: L1, L2, L3, G or L1, L2, L3, N, G				
	Bypass voltage range (V)	342-418	360-440	374-457	396-484	432-528
	Frequency (Hz)	50 or 60				
	Frequency range (Hz)	Programmable: ±0.1, ±3, ±10. Default is ±3				
	Nominal bypass current (A)	1535	1458	1405	1325	1211
	Maximum short circuit rating	100 kA RMS (conditioned by an internal molded switch with 90 kA peak magnetic trip)				
	Thyristor I ² t (kA*s ²)	9680 (1250 kW I/O) 16245 (1500 kW I/O)				9165 (1250 kW I/O) 16245 (1500 kW I/O)
	BF2 magnetic trip	39 kA				
	Protection	Molded switch with trip for backfeed protection				
	Output Specifications	Connections	IEC: L1, L2, L3, N, PE or L1, L2, L3, PE UL: L1, L2, L3, G, GEC ³⁹ or L1, L2, L3, N, G			
Overload capacity		Normal operation: 150% for 1 minute, 125% for 10 minutes Battery operation: 115% for 1 minute Bypass operation: 110% ⁴⁰ continuous, 1000% for 60 milliseconds for systems with 1250 kW I/O cabinet and 100 milliseconds for systems with 1500 kW I/O cabinet				
Output voltage tolerance		Balanced load: ±1%, Unbalanced load: ±3%				
Dynamic load response		±5% after 2 ms, ±1% after 50 ms				
Output power factor		1				
Nominal output current (A)		1519	1443	1391	1312	1203
Total harmonic distortion (THDU)		<2% at 100% linear load, <3% at 100% non-linear load				
Output frequency (Hz)		50/60 (synchronized to bypass), 50/60 Hz ±0.1% (free-running)				
Slew rate (Hz/sec)		Programmable: 0.25, 0.5, 1, 2, 4, 6				
Output performance classification (according to IEC/ EN62040-3)		Double-conversion: VFI-SS-111				
Load crest factor	Up to 3 (THDU < 5%)					
Load power factor	0.7 leading to 0.5 lagging without derating					

34. TN, TT, and IT power distribution systems are supported.

35. WYE source – solid grounded and high resistance grounded sources are supported. Corner (line) grounding is not supported.

36. The system can operate at 600 V for 1 minute.

37. At nominal input voltage and full charge.

38. TN, TT, and IT power distribution systems with no earthed line conductors are supported.

39. Per NEC 250.30.

40. 125% for 480 V.

	Voltage (V)	380	400	415	440 V	480 V
Battery Specifications	Charging power in % of output power	35% at ≤ 80% load, 12% at 100% load				40% at ≤ 80% load, 15% at 100% load
	Maximum charging power (kW)	120 at 100% load, 350 at <80% load				150 at 100% load, 400 at <80% load
	Nominal battery voltage (VDC)	480				
	Nominal float voltage (VDC)	546				
	End of discharge voltage (full load) (VDC)	384				
	End of discharge voltage (no load) (VDC)	420				
	Battery current at full load and nominal battery voltage (A)	2179				
	Battery current at full load and minimum battery voltage (A)	2724				
	Maximum battery backup time	Unlimited				
	Temperature compensation (per cell)	-3.3 mV per °C for T ≥ 25 °C, 0 mV per °C for T < 25 °C				
	Ripple current	< 5% C20 (5 minutes backup time)				
	Battery test	Manual/automatic (selectable)				
	Deep discharge protection	Yes				
	Recharge according to battery temperature	Yes				

Specifications for 1100 kW UPS

	Voltage (V)	380	400	415	440 V	480 V
Input Specifications	Connections	IEC: L1, L2, L3, PE ⁴¹ UL: L1, L2, L3 + G ⁴²				
	Input voltage range (V) ⁴³	340-456	340-480	353-498	374-528	408-576
	Frequency (Hz)	40-70				
	Nominal input current (A)	1761	1671	1609	1510	1393
	Maximum input current (A) ⁴⁴	1948	1872	1802	1691	1602
	Input current limitation (A)	1958			1830	1672
	Total harmonic distortion (THDI)	<3% at 100% load, <4% at 50% load, <9% at 25% load				
	Input power factor	0.99 at >40% load, 0.98 at >20% load, 0.97 at >10% load				
	Protection	Contactors				
	Ramp-in	Adaptive 1-300 seconds				
Bypass Specifications	Connections	IEC: L1, L2, L3, N, PE or L1, L2, L3, PE ⁴⁵ UL: L1, L2, L3, G or L1, L2, L3, N, G				
	Bypass voltage range (V)	342-418	360-440	374-457	396-484	432-528
	Frequency (Hz)	50 or 60				
	Frequency range (Hz)	Programmable: ±0.1, ±3, ±10. Default is ±3				
	Nominal bypass current (A)	1688	1604	1546	1458	1332
	Maximum short circuit rating	100 kA RMS (conditioned by an internal molded switch with 90 kA peak magnetic trip)				
	Thyristor I ² t (kA*s ²)	9680 (1250 kW I/O)				9165 (1250 kW I/O)
	BF2 magnetic trip	39 kA				
	Protection	Molded switch with trip for backfeed protection				
Output Specifications	Connections	IEC: L1, L2, L3, N, PE or L1, L2, L3, PE UL: L1, L2, L3, G, GEC ⁴⁶ or L1, L2, L3, N, G				
	Overload capacity	Normal operation: 150% for 1 minute, 125% for 10 minutes Battery operation: 115% for 1 minute Bypass operation: 110% ⁴⁷ continuous, 1000% for 60 milliseconds for systems with 1250 kW I/O cabinet and 100 milliseconds for systems with 1500 kW I/O cabinet				
	Output voltage tolerance	Balanced load: ±1%, Unbalanced load: ±3%				
	Dynamic load response	±5% after 2 ms, ±1% after 50 ms				
	Output power factor	1				
	Nominal output current (A)	1671	1588	1530	1443	1323
	Total harmonic distortion (THDU)	<2% at 100% linear load, <3% at 100% non-linear load				
	Output frequency (Hz)	50/60 (synchronized to bypass), 50/60 Hz ±0.1% (free-running)				
	Slew rate (Hz/sec)	Programmable: 0.25, 0.5, 1, 2, 4, 6				
	Output performance classification (according to IEC/ EN62040-3)	Double-conversion: VFI-SS-111				
	Load crest factor	Up to 3 (THDU < 5%)				
Load power factor	0.7 leading to 0.5 lagging without derating					

41. TN, TT, and IT power distribution systems are supported.
 42. WYE source – solid grounded and high resistance grounded sources are supported. Corner (line) grounding is not supported.
 43. The system can operate at 600 V for 1 minute.
 44. At nominal input voltage and full charge.
 45. TN, TT, and IT power distribution systems with no earthed line conductors are supported.
 46. Per NEC 250.30.
 47. 125% for 480 V.

	Voltage (V)	380	400	415	440 V	480 V
Battery Specifications	Charging power in % of output power	35% at ≤ 80% load, 12% at 100% load				40% at ≤ 80% load, 15% at 100% load
	Maximum charging power (kW)	132 at 100% load, 385 at <80% load				165 at 100% load, 440 at <80% load
	Nominal battery voltage (VDC)	480				
	Nominal float voltage (VDC)	546				
	End of discharge voltage (full load) (VDC)	384				
	End of discharge voltage (no load) (VDC)	420				
	Battery current at full load and nominal battery voltage (A)	2397				
	Battery current at full load and minimum battery voltage (A)	2996				
	Maximum battery backup time	Unlimited				
	Temperature compensation (per cell)	-3.3 mV per °C for T ≥ 25 °C, 0 mV per °C for T < 25 °C				
	Ripple current	< 5% C20 (5 minutes backup time)				
	Battery test	Manual/automatic (selectable)				
	Deep discharge protection	Yes				
	Recharge according to battery temperature	Yes				

Specifications for 1250 kW UPS

	Voltage (V)	380	400	415	440 V	480 V
Input Specifications	Connections	IEC: L1, L2, L3, PE ⁴⁸ UL: L1, L2, L3 + G ⁴⁹				
	Input voltage range (V) ⁵⁰	340-456	340-480	353-498	374-528	408-576
	Frequency (Hz)	40-70				
	Nominal input current (A)	2001	1899	1828	1716	1583
	Maximum input current (A) ⁵¹	2214	2127	2048	1922	1820
	Input current limitation (A)	2225			2080	1900
	Total harmonic distortion (THDI)	<3% at 100% load, <4% at 50% load, <9% at 25% load				
	Input power factor	0.99 at >40% load, 0.98 at >20% load, 0.97 at >10% load				
	Protection	Contactors				
	Ramp-in	Adaptive 1-300 seconds				
Bypass Specifications	Connections	IEC: L1, L2, L3, N, PE or L1, L2, L3, PE ⁵² UL: L1, L2, L3, G or L1, L2, L3, N, G				
	Bypass voltage range (V)	342-418	360-440	374-457	396-484	432-528
	Frequency (Hz)	50 or 60				
	Frequency range (Hz)	Programmable: ±0.1, ±3, ±10. Default is ±3				
	Nominal bypass current (A)	1918	1822	1757	1657	1514
	Maximum short circuit rating	100 kA RMS (conditioned by an internal molded switch with 90 kA peak magnetic trip)				
	Thyristor I ² t (kA*s ²)	9680 (1250 kW I/O) 16245 (1500 kW I/O)				9165 (1250 kW I/O) 16245 (1500 kW I/O)
	BF2 magnetic trip	39 kA				
	Protection	Molded switch with trip for backfeed protection				
	Output Specifications	Connections	IEC: L1, L2, L3, N, PE or L1, L2, L3, PE UL: L1, L2, L3, G, GEC ⁵³ or L1, L2, L3, N, G			
Overload capacity		Normal operation: 150% for 1 minute, 125% for 10 minutes Battery operation: 115% for 1 minute Bypass operation: 110% ⁵⁴ continuous, 1000% for 60 milliseconds for systems with 1250 kW I/O cabinet and 100 milliseconds for systems with 1500 kW I/O cabinet				
Output voltage tolerance		Balanced load: ±1%, Unbalanced load: ±3%				
Dynamic load response		±5% after 2 ms, ±1% after 50 ms				
Output power factor		1				
Nominal output current (A)		1899	1804	1739	1640	1504
Total harmonic distortion (THDU)		<2% at 100% linear load, <3% at 100% non-linear load				
Output frequency (Hz)		50/60 (synchronized to bypass), 50/60 Hz ±0.1% (free-running)				
Slew rate (Hz/sec)		Programmable: 0.25, 0.5, 1, 2, 4, 6				
Output performance classification (according to IEC/ EN62040-3)		Double-conversion: VFI-SS-111				
Load crest factor		Up to 3 (THDU < 5%)				
Load power factor	0.7 leading to 0.5 lagging without derating					

48. TN, TT, and IT power distribution systems are supported.

49. WYE source – solid grounded and high resistance grounded sources are supported. Corner (line) grounding is not supported.

50. The system can operate at 600 V for 1 minute.

51. At nominal input voltage and full charge.

52. TN, TT, and IT power distribution systems with no earthed line conductors are supported.

53. Per NEC 250.30.

54. 125% for 480 V.

	Voltage (V)	380	400	415	440 V	480 V
Battery Specifications	Charging power in % of output power	35% at ≤ 80% load, 12% at 100% load				40% at ≤ 80% load, 15% at 100% load
	Maximum charging power (kW)	150 at 100% load, 437 at <80% load				187.5 at 100% load, 500 at <80% load
	Nominal battery voltage (VDC)	480				
	Nominal float voltage (VDC)	546				
	End of discharge voltage (full load) (VDC)	384				
	End of discharge voltage (no load) (VDC)	420				
	Battery current at full load and nominal battery voltage (A)	2724				
	Battery current at full load and minimum battery voltage (A)	3405				
	Maximum battery backup time	1 hour				
	Temperature compensation (per cell)	-3.3 mV per °C for T ≥ 25 °C, 0 mV per °C for T < 25 °C				
	Ripple current	< 5% C20 (5 minutes backup time)				
	Battery test	Manual/automatic (selectable)				
	Deep discharge protection	Yes				
	Recharge according to battery temperature	Yes				

Specifications for 1500 kW UPS

	Voltage (V)	380	400	415	440 V	480 V
Input Specifications	Connections	IEC: L1, L2, L3, PE ⁵⁵ UL: L1, L2, L3 + G ⁵⁶				
	Input voltage range (V) ⁵⁷	340-456	340-480	353-498	374-528	408-576
	Frequency (Hz)	40-70				
	Nominal input current (A)	2401	2279	2194	2059	1899
	Maximum input current (A) ⁵⁸	2657	2552	2457	2306	2184
	Input current limitation (A)	2670			2496	2280
	Total harmonic distortion (THDI)	<3% at 100% load, <4% at 50% load, <9% at 25% load				
	Input power factor	0.99 at >40% load, 0.98 at >20% load, 0.97 at >10% load				
	Protection	Contactors				
	Ramp-in	Adaptive 1-300 seconds				
Bypass Specifications	Connections	IEC: L1, L2, L3, N, PE or L1, L2, L3, PE ⁵⁹ UL: L1, L2, L3, G or L1, L2, L3, N, G				
	Bypass voltage range (V)	342-418	360-440	374-457	396-484	432-528
	Frequency (Hz)	50 or 60				
	Frequency range (Hz)	Programmable: ±0.1, ±3, ±10. Default is ±3				
	Nominal bypass current (A)	2302	2187	2108	1988	1817
	Maximum short circuit rating	100 kA RMS (conditioned by an internal molded switch with 90 kA peak magnetic trip)				
	Thyristor I ² t (kA*s ²)	16245 (1500 kW I/O)				
	BF2 magnetic trip	39 kA				
	Protection	Molded switch with trip for backfeed protection				
Output Specifications	Connections	IEC: L1, L2, L3, N, PE or L1, L2, L3, PE UL: L1, L2, L3, G, GEC ⁶⁰ or L1, L2, L3, N, G				
	Overload capacity	150% for 1 minute, 125% for 10 minutes (normal operation) 115% for 1 minute (battery operation) 110% continuous, 1000% for 100 milliseconds (bypass operation)				
	Output voltage tolerance	Balanced load: ±1%, Unbalanced load: ±3%				
	Dynamic load response	±5% after 2 ms, ±1% after 50 ms				
	Output power factor	1				
	Nominal output current (A)	2279	2165	2087	1968	1804
	Total harmonic distortion (THDU)	<2% at 100% linear load, <3% at 100% non-linear load				
	Output frequency (Hz)	50/60 (synchronized to bypass), 50/60 Hz ±0.1% (free-running)				
	Slew rate (Hz/sec)	Programmable: 0.25, 0.5, 1, 2, 4, 6				
	Output performance classification (according to IEC/ EN62040-3)	Double-conversion: VFI-SS-111				
	Load crest factor	Up to 3 (THDU < 5%)				
Load power factor	0.7 leading to 0.5 lagging without derating					

55. TN, TT, and IT power distribution systems are supported.

56. WYE source – solid grounded and high resistance grounded sources are supported. Corner (line) grounding is not supported.

57. The system can operate at 600 V for 1 minute.

58. At nominal input voltage and full charge.

59. TN, TT, and IT power distribution systems with no earthed line conductors are supported.

60. Per NEC 250.30.

Voltage (V)		380	400	415	440 V	480 V
Battery Specifications	Charging power in % of output power	35% at ≤ 80% load, 12% at 100% load				40% at ≤ 80% load, 15% at 100% load
	Maximum charging power (kW)	525 at < 80% load, 180 at 100% load,				600 at <80% load, 225 at 100% load
	Nominal battery voltage (VDC)	480				
	Nominal float voltage (VDC)	546				
	End of discharge voltage (full load) (VDC)	384				
	End of discharge voltage (no load) (VDC)	420				
	Battery current at full load and nominal battery voltage (A)	3269				
	Battery current at full load and minimum battery voltage (A)	4086				
	Maximum battery backup time	1 hour				
	Temperature compensation (per cell)	-3.3 mV per °C for T ≥ 25 °C, 0 mV per °C for T < 25 °C				
	Ripple current	< 5% C20 (5 minutes backup time)				
	Battery test	Manual/automatic (selectable)				
	Deep discharge protection	Yes				
	Recharge according to battery temperature	Yes				

Recommended Upstream Protection and Cable Sizes – IEC

⚠ DANGER

HAZARD OF ELECTRIC SHOCK, EXPLOSION, OR ARC FLASH

An easily accessible breaker is required for upstream protection. Maximum fault current disconnection time: 46 seconds at 200% input.

Failure to follow these instructions will result in death or serious injury.

NOTE: Overcurrent protection is to be provided by others.

Cable sizes in this manual are based on table B.52.12 and B.52.13 of IEC 60364-5-52 with the following assertions:

- 90 °C conductors
- An ambient temperature of 30 °C
- Use of copper or aluminium conductors
- Installation method F4 for DC cables and installation method F5 for AC cables, corrected for single layer in perforated cable tray.

PE cables are sized in accordance with IEC 60364-5-54 table 54.2 Minimum cross-sectional area of protective conductors.

NOTE: Always consider the PE size according to the complete electrical installation.

If the ambient temperature is greater than 30 °C, larger conductors are to be selected in accordance with the correction factors of the IEC.

NOTE: The use of aluminium conductors can limit the number of parallel Li-ion battery cabinets. Please contact Schneider Electric for more information.

Recommended Upstream Protection and Cable Sizes for 500 kW UPS

Voltage (V)	Maximum OCPD (A)				Conductors per Phase Copper/ Aluminium (mm ²)				PE Conductor (mm ²)			
	380	400	415	440	380	400	415	440	380	400	415	440
Input	1000 <i>I_r</i> =0.90	1000 <i>I_r</i> =0.90	1000 <i>I_r</i> =0.90	1000 <i>I_r</i> =0.90	2x240/ 3x185	2x240/ 3x185	2x240/ 3x185	2x240/ 3x185	1x240/ 2x150	1x240/ 2x150	1x240/ 2x150	1x240/ 2x150
Bypass	800 <i>I_r</i> =0.98	800 <i>I_r</i> =0.95	800 <i>I_r</i> =0.9	800 <i>I_r</i> =0.9	2x185/ 2x240	2x150/ 2x240	2x150/ 2x240	2x150/ 2x240	1x185/ 1x240	1x150/ 1x240	1x150/ 1x240	1x150/ 1x240
Output	800 <i>I_r</i> =0.98	800 <i>I_r</i> =0.95	800 <i>I_r</i> =0.9	800 <i>I_r</i> =0.9	2x185/ 2x240	2x150/ 2x240	2x150/ 2x240	2x150/ 2x240	1x185/ 1x240	1x150/ 1x240	1x150/ 1x240	1x150/ 1x240
Battery	1500	1500	1500	1500	3x185/ 3x240	3x185/ 3x240	3x185/ 3x240	3x185/ 3x240	2x150/ 2x185	2x150/ 2x185	2x150/ 2x185	2x150/ 2x185

Recommended Upstream Protection and Cable Sizes for 625 kW UPS

	Maximum OCPD (A)				Conductors per Phase Copper/ Aluminium (mm ²)				PE Conductor (mm ²)			
	380 V	400 V	415 V	440 V	380 V	400 V	415 V	440 V	380 V	400 V	415 V	440 V
Input	1250 <i>I_r</i> =0.9	1250 <i>I_r</i> =0.9	1250 <i>I_r</i> =0.9	1250 <i>I_r</i> =0.9	3x185/ 3x240	3x185/ 3x240	3x185/ 3x240	3x185/ 3x240	2x150/ 2x185	2x150/ 2x185	2x150/ 2x185	2x150/ 2x185
Bypass	1000 <i>I_r</i> =0.98	1000 <i>I_r</i> =0.95	1000 <i>I_r</i> =0.9	1000 <i>I_r</i> =0.9	2x240/ 3x240	2x240/ 3x185	2x240/ 3x185	2x240/ 3x185	1x240/ 2x185	1x240/ 2x150	1x240/ 2x150	1x240/ 2x150
Output	1000 <i>I_r</i> =0.98	1000 <i>I_r</i> =0.95	1000 <i>I_r</i> =0.9	1000 <i>I_r</i> =0.9	2x240/ 3x240	2x240/ 3x185	2x240/ 3x185	2x240/ 3x185	1x240/ 2x185	1x240/ 2x150	1x240/ 2x150	1x240/ 2x150
Battery	2000	2000	2000	2000	3x240/ 4x240	3x240/ 4x240	3x240/ 4x240	3x240/ 4x240	2x185/ 2x240	2x185/ 2x240	2x185/ 2x240	2x185/ 2x240

Recommended Upstream Protection and Cable Sizes for 750 kW UPS

Voltage (V)	Maximum OCPD (A)				Conductors per Phase Copper/ Aluminium (mm ²)				PE Conductor (mm ²)			
	380	400	415	440	380	400	415	440	380	400	415	440
Input	1600 <i>I_r</i> =0.9	1600 <i>I_r</i> =0.9	1600 <i>I_r</i> =0.9	1250 <i>I_r</i> =1.0	3x240/ 4x240	3x240/ 4x240	3x240/ 4x240	3x185/ 4x240	2x185/ 2x240	2x185/ 2x240	2x185/ 2x240	2x150/ 2x240
Bypass	1250 <i>I_r</i> =0.95	1250 <i>I_r</i> =0.9	1250 <i>I_r</i> =0.9	1000 <i>I_r</i> = 1.0	3x185/ 4x185	3x185/ 3x240	3x185/ 3x240	2x240/ 3x240	2x150/ 2x185	2x150/ 2x185	2x150/ 2x185	1x240/ 2x185
Output	1250 <i>I_r</i> =0.95	1250 <i>I_r</i> =0.9	1250 <i>I_r</i> =0.9	1000 <i>I_r</i> =1.0	3x185/ 4x185	3x185/ 3x240	3x185/ 3x240	2x240/ 3x240	2x150/ 2x185	2x150/ 2x185	2x150/ 2x185	1x240/ 2x185
Battery	2500	2500	2500	2500	4x240/ 5x240	4x240/ 5x240	4x240/ 5x240	4x240/ 5x240	2x240/ 3x240	2x240/ 3x240	2x240/ 3x240	2x240/ 3x240

Recommended Upstream Protection and Cable Sizes for 800 kW UPS

Voltage (V)	Maximum OCPD (A)				Conductors per Phase Copper/ Aluminium (mm ²)				PE Conductor (mm ²)			
	380	400	415	440	380	400	415	440	380	400	415	440
Input	1600 <i>I_r</i> =0.9	1600 <i>I_r</i> =0.9	1600 <i>I_r</i> =0.9	1600 <i>I_r</i> =0.9	3x240/ 4x240	3x240/ 4x240	3x240/ 4x240	3x240/ 4x240	2x185/ 2x240	2x185/ 2x240	2x185/ 2x240	2x185/ 2x240
Bypass	1250 <i>I_r</i> =1.0	1250 <i>I_r</i> =0.95	1250 <i>I_r</i> =0.9	1250 <i>I_r</i> =0.9	3x185/ 4x240	3x185/ 4x185	3x185/ 3x240	3x185/ 3x240	2x150/ 2x185	2x150/ 2x185	2x150/ 2x185	2x150/ 2x185
Output	1250 <i>I_r</i> =1.0	1250 <i>I_r</i> =0.95	1250 <i>I_r</i> =0.9	1250 <i>I_r</i> =0.9	3x185/ 4x240	3x185/ 4x185	3x185/ 3x240	3x185/ 3x240	2x150/ 2x185	2x150/ 2x185	2x150/ 2x185	2x150/ 2x185
Battery	2500	2500	2500	2500	4x240/ 5x240	4x240/ 5x240	4x240/ 5x240	4x240/ 5x240	2x240/ 3x240	2x240/ 3x240	2x240/ 3x240	2x240/ 3x240

Recommended Upstream Protection and Cable Sizes for 1000 kW UPS

Voltage (V)	Maximum OCPD (A)				Conductors per Phase Copper/ Aluminium (mm ²)				PE Conductor (mm ²)			
	380	400	415	440	380	400	415	440	380	400	415	440
Input	2000 I _r =0.9	2000 I _r =0.9	2000 I _r =0.9	2000 I _r =0.9	4x240/ 6x240	4x240/ 6x240	4x240/ 6x240	4x240/ 6x240	2x240/ 3x240	2x240/ 3x240	2x240/ 3x240	2x240/ 3x240
Bypass	1600 I _r =0.98	1600 I _r =0.95	1600 I _r =0.9	1600 I _r =0.9	4x185/ 5x240	4x185/ 5x240	3x240/ 4x240	3x240/ 4x240	2x185/ 3x240	2x185/ 3x240	2x185/ 2x240	2x185/ 2x240
Output	1600 I _r =0.98	1600 I _r =0.98	1600 I _r =0.9	1600 I _r =0.9	4x240/ 6x240	4x240/ 6x240	3x240/ 6x240	3x240/ 6x240	2x240/ 3x240	2x240/ 3x240	2x240/ 3x240	2x240/ 3x240
Battery	3300	3300	3300	3300	5x240/ 7x240	5x240/ 7x240	5x240/ 7x240	5x240/ 7x240	3x240/ 4x240	3x240/ 4x240	3x240/ 4x240	3x240/ 4x240

Recommended Upstream Protection and Cable Sizes for 1100 kW UPS

Voltage (V)	Maximum OCPD (A)				Conductors per Phase Copper/ Aluminium (mm ²)				PE Conductor (mm ²)			
	380	400	415	440	380	400	415	440	380	400	415	440
Input	2000 I _r =0.98	2000 I _r =0.98	2000 I _r =0.98	2000 I _r =0.95	4x300/ 5x300	4x300/ 5x300	4x300/ 5x300	4x300/ 5x300	2x300/ 3x300	2x300/ 3x300	2x300/ 3x300	2x300/ 3x300
Bypass	2000 I _r =0.9	2000 I _r =0.9	1600 I _r =0.98	1600 I _r =0.95	4x240/ 5x300	4x240/ 5x300	3x300/ 4x300	3x300/ 4x300	2x240/ 3x300	2x240/ 3x300	2x240 2x300	2x240/ 2x300
Output	2000 I _r =0.9	2000 I _r =0.9	1600 I _r =0.98	1600 I _r =0.95	4x240/ 5x300	4x240/ 5x300	3x300/ 4x300	3x300/ 4x300	2x240/ 3x300	2x240/ 3x300	2x240 2x300	2x240/ 2x300
Battery	3300	3300	3300	3300	5x300/ 7x300	5x300/ 7x300	5x300/ 7x300	5x300/ 7x300	3x300/ 4x300	3x300/ 4x300	3x300/ 4x300	3x300/ 4x300

Recommended Upstream Protection and Cable Sizes for 1250 kW UPS

	Maximum OCPD (A)				Conductors per Phase Copper/ Aluminium (mm ²)				PE Conductor (mm ²)			
	380 V	400 V	415 V	440 V	380 V	400 V	415 V	440 V	380 V	400 V	415 V	440 V
Input	2500 I _r =0.9	2500 I _r =0.9	2500 I _r =0.9	2500 I _r =0.9	5x240/ 6x300	5x240/ 6x300	5x240/ 6x300	5x240/ 6x300	3x240/ 3x300	3x240/ 3x300	3x240/ 3x300	3x240/ 3x300
Bypass	2000 I _r =0.98	2000 I _r =0.95	2000 I _r =0.9	2000 I _r =0.9	4x300/ 5x300	4x300/ 5x300	4x240/ 5x300	4x240/ 5x300	2x300/ 3x300	2x300/ 3x300	2x240/ 3x300	2x240/ 3x300
Output	2000 I _r =0.98	2000 I _r =0.95	2000 I _r =0.9	2000 I _r =0.9	4x300/ 5x300	4x300/ 5x300	4x240/ 5x300	4x240/ 5x300	2x300/ 3x300	2x300/ 3x300	2x240/ 3x300	2x240/ 3x300
Battery	4000	4000	4000	4000	6x300/ 7x300	6x300/ 7x300	6x300/ 7x300	6x300/ 7x300	3x300/ 4x300	3x300/ 4x300	3x300/ 4x300	3x300/ 4x300

Recommended Upstream Protection and Cable Sizes for 1500 kW UPS

	Maximum OCPD (A)				Conductors per Phase Copper/ Aluminium (mm ²)				PE Conductor (mm ²)			
	380 V	400 V	415 V	440 V	380 V	400 V	415 V	440 V	380 V	400 V	415 V	440 V
Input	3200 ⁶¹	3200 ⁶¹	3200 ⁶¹	2500 ⁶²	7x240/ 9x240	7x240/ 9x240	7x240/ 9x240	6x240/ 8x240	4x240/ 5x240	4x240/ 5x240	4x240/ 5x240	3x240/ 4x240
Bypass	2500 ⁶³	2500 ⁶¹	2500 ⁶¹	2000 ⁶²	6x240/ 7x240	5x240/ 7x240	5x240/ 7x240	5x240/ 6x240	3x240/ 4x240	3x240/ 4x240	3x240/ 4x240	3x240/ 3x240
Output	2500 ⁶³	2500 ⁶¹	2500 ⁶¹	2000 ⁶²	6x240/ 7x240	5x240/ 7x240	5x240/ 7x240	5x240/ 6x240	3x240/ 4x240	3x240/ 4x240	3x240/ 4x240	3x240/ 3x240
Battery	4000	4000	4000	4000	8x240/ 10x240	8x240/ 10x240	8x240/ 10x240	8x240/ 10x240	4x240/ 5x240	4x240/ 5x240	4x240/ 5x240	4x240/ 5x240

Weights and Dimensions

Weights and Dimensions for UPSs with 1250 kW I/O Cabinet

Commercial Reference	Parts	Weight kg	Height mm	Width mm	Depth mm
<ul style="list-style-type: none"> GVX500K500NHS GVX500K750NHS GVX500K1000NHS GVX500K1250NHS 	Total – Power cabinets – I/O cabinet	2030 (4475) 2x540 (2x1190) 950 (2094)	1970 (77.6)	2400 (94.5) 2x600 (2x23.6) 1200 (47.2)	900 (35.4)
<ul style="list-style-type: none"> GVX625K625NHS GVX625K1000NHS GVX750K500NHS GVX750K750NHS GVX750K1000NHS GVX750K1250NHS 	Total – Power cabinets – I/O cabinet	2570 (5666) 3x540 (3x1190) 950 (2094)	1970 (77.6)	3000 (118.1) 3x600 (3x23.6) 1200 (47.2)	900 (35.4)
<ul style="list-style-type: none"> GVX800K800NHS GVX1000K750NHS GVX1000K1000NHS GVX1000K1250NHS 	Total – Power cabinets – I/O cabinet	3110 (6856) 4x540 (4x1190) 950 (2094)	1970 (77.6)	3600 (141.7) 4x600 (4x23.6) 1200 (47.2)	900 (35.4)
<ul style="list-style-type: none"> GVX1100K1100NHS GVX1250K1000NHS GVX1250K1250NHS 	Total – Power cabinets – I/O cabinet	3650 (8047) 5x540 (5x1190) 950 (2094)	1970 (77.6)	4200 (165.4) 5x600 (5x23.6) 1200 (47.2)	900 (35.4)
<ul style="list-style-type: none"> GVX1500K1100NHS GVX1500K1250NHS 	Total – Power cabinets – I/O cabinet	4190 (9237) 6x540 (6x1190) 950 (2094)	1970 (77.6)	4800 (189.0) 6x600 (6x23.6) 1200 (47.2)	900 (35.4)

61. Long-time setting (I_r) = 0.9.
 62. Long-time setting (I_r) = 1.0.
 63. Long-time setting (I_r) = 0.95.

Weights and Dimensions for UPSs with 1500 kW I/O Cabinet

Part Number	Parts	Weight kg (lbs)	Height mm (in)	Width mm (in)	Depth mm (in)
• GVX500K1500HS	In total – Power cabinets – I/O cabinet	1956 (4312) 2x540 (2x1190) 876 (1931)	1970 (77.6)	3200 (126.0) 2x600 (2x23.6) 2000 (78.7)	900 (35.4)
• GVX750K1500HS	In total – Power cabinets – I/O cabinet	2496 (5503) 3x540 (3x1190) 876 (1931)	1970 (77.6)	3800 (149.6) 3x600 (3x23.6) 2000 (78.7)	900 (35.4)
• GVX1000K1500HS	In total – Power cabinets – I/O cabinet	3036 (6693) 4x540 (4x1190) 876 (1931)	1970 (77.6)	4400 (173.2) 4x600 (4x23.6) 2000 (78.7)	900 (35.4)
• GVX1250K1500HS	In total – Power cabinets – I/O cabinet	3576 (7884) 5x540 (5x1190) 876 (1931)	1970 (77.6)	5000 (196.9) 5x600 (5x23.6) 2000 (78.7)	900 (35.4)
• GVX1500K1500HS	In total – Power cabinets – I/O cabinet	4116 (9074) 6x540 (6x1190) 876 (1931)	1970 (77.6)	5600 (220.5) 6x600 (6x23.6) 2000 (78.7)	900 (35.4)
• GVX1750K1500HS	In total – Power cabinets – I/O cabinet	4656 (10265) 7x540 (7x1190) 876 (1931)	1970 (77.6)	6200 (244.1) 7x600 (7x23.6) 2000 (78.7)	900 (35.4)

Clearance

Clearance for UPSs with 1250 kW I/O Cabinet

NOTE: Clearance dimensions are published for airflow and service access only. Consult with the local safety codes and standards for additional requirements in your local area.

NOTE: The UPS system can be placed up against a wall and there is no requirement for rear or side access.

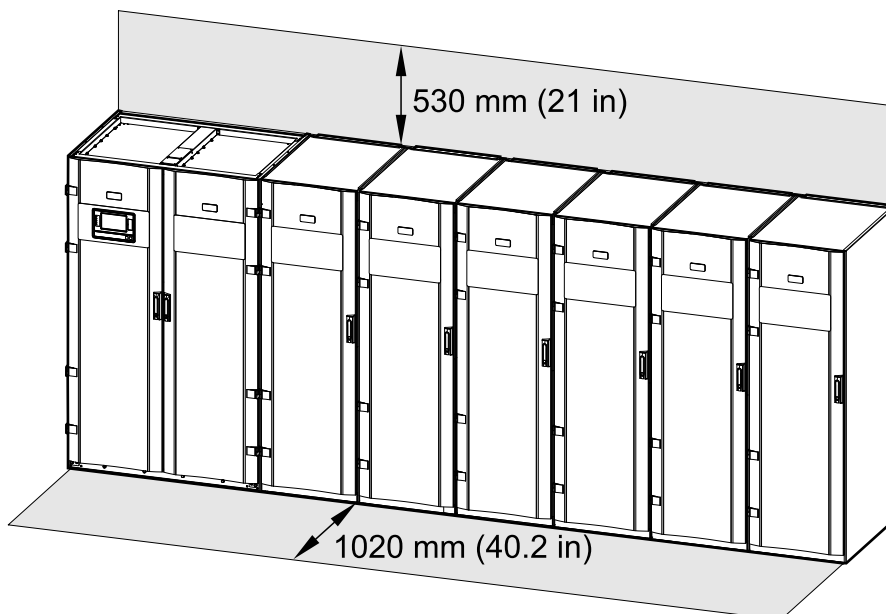

Clearance for UPSs with 1500 kW I/O Cabinet

NOTE: Clearance dimensions are published for airflow and service access only. Consult with the local safety codes and standards for additional requirements in your local area.

NOTE: The UPS system can be placed up against a wall with no requirement for rear or side access.

Front View

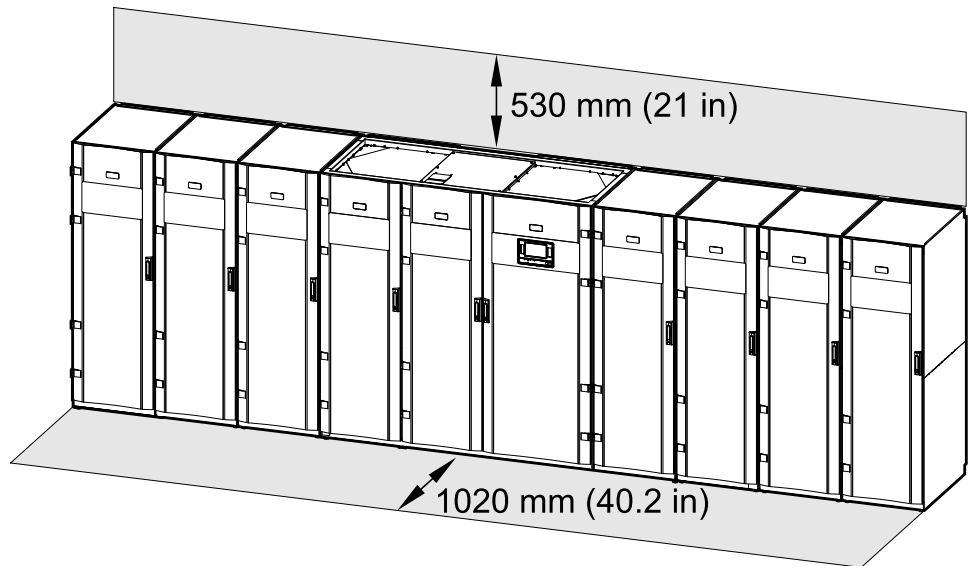

Guidance for Organizing Battery Cables

NOTE: For 3rd party batteries, use only high rate batteries for UPS applications.

NOTE: When the battery bank is placed remotely, the organizing of the cables is important to reduce voltage drop and inductance. The distance between the battery bank and the UPS must not exceed 200 m (656 ft). Contact Schneider Electric for installations with a longer distance.

NOTE: To minimize the risk of electromagnetic radiation, it is highly recommended to follow the below guidance and to use grounded metallic tray supports.

Cable Length				
<30 m	Not recommended	Acceptable	Recommended	Recommended
31–75 m	Not recommended	Not recommended	Acceptable	Recommended
76–150 m	Not recommended	Not recommended	Acceptable	Recommended
151–200 m	Not recommended	Not recommended	Not recommended	Recommended

Torque Specifications

Bolt size	Torque
M6	5 Nm (3.69 lb-ft)
M8	17.5 Nm (12.91 lb-ft)
M10	30 Nm (22 lb-ft)
M12	50 Nm (36.87 lb-ft)

Environment

	Operating	Storage
Temperature	0 °C to 40 °C (32 °F to 104 °F) 0 °C to 50 °C (32 °F to 122 °F) when derated to 75% power ⁶⁴	-15 °C to 40 °C (5 °F to 104 °F) for systems with batteries -25 °C to 55 °C (-13 °F to 131 °F) for systems without batteries
Relative humidity	0 – 95% non-condensing	0 – 95% non-condensing
Altitude derating according to ANSI C57.96–1999 ⁶⁵	1000 m (3300 ft): 1.000 1500 m (5000 ft): 0.975 2000 m (6600 ft): 0.950 2500 m (8300 ft): 0.925 3000 m (10000 ft): 0.900	0 – 15000 m (0 – 50000 ft)
Audible noise one meter (three feet) from surface	62 dB at 70% load 69.5 dB at 100% load for 400 V systems 68 dB at 100% load for 480 V systems	
Protection class	IP20	
Color	RAL 9003 white	

Heat Dissipation (BTU/hr) for UPSs with 1250 kW I/O Cabinet

Heat Dissipation for 500 kW UPS

Voltage (V)	Normal operation					ECO mode				
	380	400	415	440 V	480 V	380	400	415	440 V	480 V
25% load	17771	21504	21504	21504	22920	11385	16847	16387	14099	11835
50% load	34617	38327	38327	37397	36468	8616	11235	10360	12112	13870
75% load	56095	58889	58889	56095	53313	12924	15540	15540	15540	15540
100% load	78519	80387	78519	75723	72936	13758	17232	17232	17232	17232

Voltage (V)	ECOversion					Battery operation				
	380	400	415	440 V	480 V	380	400	415	440 V	480 V
25% load	4308	7376	6935	10264	13644	14555	15469	15011	15011	15011
50% load	13870	12990	16521	16078	15635	29110	29110	30938	30938	29110
75% load	12924	14231	14231	15540	16853	75903	47782	49160	49160	49160
100% load	17232	13758	13758	16362	18975	71083	74793	80387	80387	72936

Heat Dissipation for 625 kW UPS

Voltage (V)	Normal operation					ECO mode				
	380	400	415	440 V	480 V	380	400	415	440 V	480 V
25% load	27469	26880	26880	26880	28059	10880	13110	13670	13670	13670
50% load	47909	47909	47909	45006	42118	11859	14044	15139	15139	15139
75% load	73611	73611	73611	67509	61451	16155	19426	19426	19426	19426
100% load	114602	100484	98149	91170	84236	23718	25901	25901	23718	21540

64. For temperatures between 40 °C and 50 °C, the load power rating must be derated with 2.5% per °C of rated output power. Above 40 °C the minimum input voltage is 340 V, and from 380 V to 340 V, the charge power must be linearly derated from 12% to 1%.

65. Maximum operation altitude is 3000 m (10000 ft).

	ECOConversion					Battery operation				
Voltage (V)	380	400	415	440 V	480 V	380	400	415	440 V	480 V
25% load	15922	15922	10880	13390	15922	17056	17056	18764	18764	18764
50% load	17337	17337	17337	17337	17337	40967	39818	38672	38672	36387
75% load	21066	21066	21066	21066	21066	61451	61451	61451	61451	61451
100% load	25901	25901	25901	24809	23718	86543	84236	100484	100484	91170

Heat Dissipation for 750 kW UPS

	Normal operation					ECO mode				
Voltage (V)	380	400	415	440 V	480 V	380	400	415	440 V	480 V
25% load	28745	30847	30847	30847	30847	10402	13056	13723	13723	13723
50% load	56095	56095	54702	53313	51926	14231	16853	18167	18167	18167
75% load	94653	92542	86236	83097	79969	19386	23311	23311	23311	23311
100% load	146074	137523	129025	120581	112190	25848	28462	28462	28462	28462

	ECOConversion					Battery operation				
Voltage (V)	380	400	415	440 V	480 V	380	400	415	440 V	480 V
25% load	15061	15061	9084	12058	15061	21832	21832	22517	22517	23203
50% load	19485	19485	19485	19485	19485	45034	43664	45034	45034	45034
75% load	25279	25279	25279	25279	25279	77888	75812	75812	75812	75812
100% load	31081	31081	31081	29771	28462	114981	112190	112190	112190	112190

Heat Dissipation for 800 kW UPS

	Normal operation					ECO mode				
Voltage (V)	380	400	415	440 V	480 V	380	400	415	440 V	480 V
25% load	35160	35160	34407	34407	34407	15351	15351	8988	8988	8988
50% load	59835	58349	56867	55387	53911	19378	19378	15180	15180	15180
75% load	91985	89752	85300	84190	83081	22770	22770	22770	22770	22770
100% load	131616	128620	119669	112253	104876	30360	27572	27572	27572	27572

	ECOConversion					Battery operation				
Voltage (V)	380	400	415	440 V	480 V	380	400	415	440 V	480 V
25% load	17497	18216	17497	17857	18216	26956	21831	21105	21105	7590
50% load	20784	20784	20784	20784	20784	50968	43662	48036	48036	48036
75% load	24865	24865	24865	24865	24865	78657	65493	67676	67676	67676
100% load	30360	30360	27572	26180	24790	113733	101935	104876	104876	104876

Heat Dissipation for 1000 kW UPS

	Normal operation					ECO mode				
Voltage (V)	380	400	415	440 V	480 V	380	400	415	440 V	480 V
25% load	36468	39259	39259	39259	39259	12112	15635	16521	16521	16521
50% load	71083	71083	69234	69234	65547	15493	18975	20721	20721	20721
75% load	120581	117778	109405	109405	101083	20637	25848	25848	25848	25848
100% load	187156	175802	164520	164520	142167	27516	30987	30987	30987	30987

Voltage (V)	ECOversion					Battery operation				
	380	400	415	440 V	480 V	380	400	415	440 V	480 V
25% load	18297	18297	10360	14311	18297	28198	28198	29110	29110	30023
50% load	22470	22470	22470	22470	22470	58219	56397	58219	58219	58219
75% load	28462	28462	28462	28462	28462	101083	98321	98321	98321	98321
100% load	34465	34465	34465	32725	30987	149587	145873	145873	145873	145873

Heat Dissipation for 1100 kW UPS

Voltage (V)	Normal operation					ECO mode				
	380	400	415	440 V	480 V	380	400	415	440 V	480 V
25% load	43185	43185	42160	43185	41136	18173	17199	17199	16713	16227
50% load	82273	78192	76158	76158	70080	22793	22793	22793	21832	20872
75% load	132639	123409	120345	120345	108153	28433	25564	25564	26998	28433
100% load	201700	185100	180972	180972	152315	37911	37911	37911	35997	34086

Voltage (V)	ECOversion					Battery operation				
	380	400	415	440 V	480 V	380	400	415	440 V	480 V
25% load	21107	21107	20127	18173	21107	35040	37064	36051	32021	36051
50% load	24717	22793	24717	22793	24717	66050	66050	70080	64041	68063
75% load	34189	34189	34189	28433	31308	163830	102095	105121	108153	105121
100% load	53291	41744	41744	34086	37911	156383	164545	176852	160460	152315

Heat Dissipation for 1250 kW UPS

Voltage (V)	Normal operation					ECO mode				
	380	400	415	440 V	480 V	380	400	415	440 V	480 V
25% load	49074	49074	47909	47909	46746	20651	19544	19544	18992	18440
50% load	93492	88854	86543	83084	79637	25901	25901	25901	24809	23718
75% load	154237	143726	140237	133281	126354	35578	32311	32311	30680	29050
100% load	233945	215042	210341	193965	177708	43081	43081	43081	40906	38734

Voltage (V)	ECOversion					Battery operation				
	380	400	415	440 V	480 V	380	400	415	440 V	480 V
25% load	22872	22872	21760	22316	22872	36387	38672	37528	37528	37528
50% load	28088	25901	28088	28088	28088	72774	72774	77345	77345	75057
75% load	35578	35578	35578	33943	32311	119455	119455	122901	122901	122901
100% load	56175	43081	43081	40906	38734	177708	186983	200969	200969	173085

Heat Dissipation (BTU/hr) for UPSs with 1500 kW I/O Cabinet

Heat Dissipation for 500 kW UPS

Voltage (V)	Normal operation					ECO mode				
	380	400	415	440 V	480 V	380	400	415	440 V	480 V
25% load	17309	16387	16387	16387	18698	5618	5618	5618	6056	6495
50% load	32774	30938	30938	31396	31855	7747	7747	7747	7747	7747
75% load	53313	50542	50542	50542	50542	11620	11620	11620	10969	10319
100% load	86017	82260	82260	75723	69234	13758	13758	13758	13758	13758

Voltage (V)	ECOConversion					Battery operation				
	380	400	415	440 V	480 V	380	400	415	440 V	480 V
25% load	6495	6495	6495	7155	7818	18234	18234	18234	18234	18234
50% load	7747	7747	7747	7747	7747	31855	31855	31855	31855	31855
75% load	11620	11620	11620	10969	10319	53313	53313	53313	53313	53313
100% load	15493	13758	13758	13758	13758	78519	78519	78519	78519	78519

Heat Dissipation for 750 kW UPS

Voltage (V)	Normal operation					ECO mode				
	380	400	415	440 V	480 V	380	400	415	440 V	480 V
25% load	26656	25271	25271	25271	27351	9084	9084	9084	9413	9742
50% load	51926	49160	49160	47782	46407	12924	12924	12924	12272	11620
75% load	86236	82053	82053	77888	73741	17430	17430	17430	16453	15478
100% load	134684	129025	129025	117778	106625	23240	23240	23240	21938	20637

Voltage (V)	ECOConversion					Battery operation				
	380	400	415	440 V	480 V	380	400	415	440 V	480 V
25% load	9742	9742	9742	10733	11727	27351	27351	27351	27351	27351
50% load	12924	12924	12924	12924	12924	47782	47782	47782	47782	47782
75% load	17430	17430	17430	16453	15478	79969	79969	79969	79969	79969
100% load	23240	23240	23240	21938	20637	117778	117778	117778	117778	117778

Heat Dissipation for 1000 kW UPS

Voltage (V)	Normal operation					ECO mode				
	380	400	415	440 V	480 V	380	400	415	440 V	480 V
25% load	36468	34617	34617	33888	36468	12112	12112	12112	12112	12112
50% load	71083	67389	67389	60137	61876	17232	17232	17232	16362	15493
75% load	123390	117778	117778	98514	95564	23240	23240	23240	21938	20637
100% load	187156	179579	179579	149141	145873	30987	30987	30987	29251	27516

Voltage (V)	ECOversion					Battery operation				
	380	400	415	440 V	480 V	380	400	415	440 V	480 V
25% load	13334	13334	13334	14313	15294	36468	35819	36468	36468	36468
50% load	17254	17254	17254	16956	16657	63710	62976	63710	63710	63710
75% load	24358	24358	24358	22496	20637	106625	104128	106625	106625	106625
100% load	31342	31342	31342	29428	27516	157038	156664	157038	157038	157038

Heat Dissipation for 1250 kW UPS

Voltage (V)	Normal operation					ECO mode				
	380	400	415	440 V	480 V	380	400	415	440 V	480 V
25% load	44427	42118	42118	42118	44427	12950	12950	12950	13497	14044
50% load	86543	81934	81934	78490	75057	19367	19367	19367	18282	17198
75% load	147223	140237	140237	129814	119455	25796	25796	25796	24172	22549
100% load	224474	215042	215042	196297	177708	30065	30065	30065	30065	30065

Voltage (V)	ECOversion					Battery operation				
	380	400	415	440 V	480 V	380	400	415	440 V	480 V
25% load	15569	15569	15569	17156	18748	45585	45585	45585	45585	45585
50% load	19394	19394	19394	19721	20047	79637	79637	79637	79637	79637
75% load	27191	27191	27191	25681	24172	133281	133281	133281	133281	133281
100% load	34838	34838	34838	32451	30065	196297	196297	196297	196297	196297

Heat Dissipation for 1500 kW UPS

Voltage (V)	Normal operation					ECO mode				
	380	400	415	440 V	480 V	380	400	415	440 V	480 V
25% load	53313	50542	50542	50680	53313	15540	15540	15540	16131	16853
50% load	103851	98321	98321	91275	92813	23240	23240	23240	21626	23240
75% load	176667	168285	168285	151832	147481	30956	30956	30956	28889	27059
100% load	269368	258050	258050	234549	213250	36079	36079	36079	37428	36079

Voltage (V)	ECOversion					Battery operation				
	380	400	415	440 V	480 V	380	400	415	440 V	480 V
25% load	18683	18683	18683	17234	22054	54702	51372	54702	54702	54285
50% load	23273	23273	23273	20325	23129	95564	95014	95564	95564	96666
75% load	32629	32629	32629	26436	27059	159938	159521	159938	159938	154530
100% load	41806	41806	41806	35819	36079	235556	236677	235556	235556	229962

Options

Hardware Options

- Standard top cable entry battery cabinets or custom front terminal battery cabinets
- Optional remote 10-inch LCD
- Optional Modbus RS-485 card

Configuration Options

- Single or dual feed
- Default top or bottom cable entry
- N+1 redundancy
- Up to 4+1 UPSs in parallel
- ECO mode
- ECOConversion mode
- StruxureWare Data Center Expert compatible
- Generator compatible
- Internal synchronization to alternate source (single system)
- Seismic rated brackets included
- Touchscreen LCD

Limited Factory Warranty

One-Year Factory Warranty

The limited warranty provided by Schneider Electric in this Statement of Limited Factory Warranty applies only to products you purchase for your commercial or industrial use in the ordinary course of your business.

Terms of Warranty

Schneider Electric warrants that the product shall be free from defects in materials and workmanship for a period of one year from the date of product start-up when start-up is performed by Schneider Electric-authorized service personnel and occurs within six months of the Schneider Electric shipment date. This warranty covers repairing or replacing any defective parts including on-site labor and travel. In the event that the product fails to meet the foregoing warranty criteria, the warranty covers repairing or replacing defective parts at the sole discretion of Schneider Electric for a period of one year from the shipment date. For Schneider Electric cooling solutions, this warranty does not cover circuit breaker resetting, loss of refrigerant, consumables, or preventive maintenance items. Repair or replacement of a defective product or part thereof does not extend the original warranty period. Any parts furnished under this warranty may be new or factory-remanufactured.

Non-transferable Warranty

This warranty is extended to the first person, firm, association or corporation (herein referred to by "You" or "Your") for whom the Schneider Electric product specified herein has been purchased. This warranty is not transferable or assignable without the prior written permission of Schneider Electric.

Assignment of Warranties

Schneider Electric will assign you any warranties which are made by manufacturers and suppliers of components of the Schneider Electric product and which are assignable. Any such warranties are assigned "AS IS" and Schneider Electric makes no representation as to the effectiveness or extent of such warranties, assumes no responsibility for any matters which may be warranted by such manufacturers or suppliers and extends no coverage under this Warranty to such components.

Drawings, Descriptions

Schneider Electric warrants for the warranty period and on the terms of the warranty set forth herein that the Schneider Electric product will substantially conform to the descriptions contained in the Schneider Electric Official Published Specifications or any of the drawings certified and agreed to by contract with Schneider Electric if applicable thereto ("Specifications"). It is understood that the Specifications are not warranties of performance and not warranties of fitness for a particular purpose.

Exclusions

Schneider Electric shall not be liable under the warranty if its testing and examination disclose that the alleged defect in the product does not exist or was caused by end user or any third person misuse, negligence, improper installation or testing. Further, Schneider Electric shall not be liable under the warranty for unauthorized attempts to repair or modify wrong or inadequate electrical voltage or connection, inappropriate on-site operation conditions, corrosive atmosphere, repair, installation, start-up by non-Schneider Electric designated personnel, a change in location or operating use, exposure to the elements, Acts of God, fire, theft, or installation contrary to Schneider Electric recommendations or specifications or in any event if the Schneider Electric serial number has been altered, defaced, or removed, or any other cause beyond the range of the intended use.

THERE ARE NO WARRANTIES, EXPRESS OR IMPLIED, BY OPERATION OF LAW OR OTHERWISE, OF PRODUCTS SOLD, SERVICED OR FURNISHED UNDER THIS AGREEMENT OR IN CONNECTION HEREWITH. SCHNEIDER ELECTRIC DISCLAIMS ALL IMPLIED WARRANTIES OF MERCHANTABILITY, SATISFACTION AND FITNESS FOR A PARTICULAR PURPOSE. SCHNEIDER ELECTRIC EXPRESS WARRANTIES WILL NOT BE ENLARGED, DIMINISHED, OR AFFECTED BY AND NO OBLIGATION OR LIABILITY WILL ARISE OUT OF, SCHNEIDER ELECTRIC RENDERING OF TECHNICAL OR OTHER ADVICE OR SERVICE IN CONNECTION WITH THE PRODUCTS. THE FOREGOING WARRANTIES AND REMEDIES ARE EXCLUSIVE AND IN LIEU OF ALL OTHER WARRANTIES AND REMEDIES. THE WARRANTIES SET FORTH ABOVE CONSTITUTE SCHNEIDER ELECTRIC SOLE LIABILITY AND PURCHASER'S EXCLUSIVE REMEDY FOR ANY BREACH OF SUCH WARRANTIES. SCHNEIDER ELECTRIC WARRANTIES RUN ONLY TO PURCHASER AND ARE NOT EXTENDED TO ANY THIRD PARTIES.

IN NO EVENT SHALL SCHNEIDER ELECTRIC, ITS OFFICERS, DIRECTORS, AFFILIATES OR EMPLOYEES BE LIABLE FOR ANY FORM OF INDIRECT, SPECIAL, CONSEQUENTIAL OR PUNITIVE DAMAGES, ARISING OUT OF THE USE, SERVICE OR INSTALLATION, OF THE PRODUCTS, WHETHER SUCH DAMAGES ARISE IN CONTRACT OR TORT, IRRESPECTIVE OF FAULT, NEGLIGENCE OR STRICT LIABILITY OR WHETHER SCHNEIDER ELECTRIC HAS BEEN ADVISED IN ADVANCE OF THE POSSIBILITY OF SUCH DAMAGES, SPECIFICALLY, SCHNEIDER ELECTRIC IS NOT LIABLE FOR ANY COSTS, SUCH AS LOST PROFITS OR REVENUE, LOSS OF EQUIPMENT, LOSS OF USE OF EQUIPMENT, LOSS OF SOFTWARE, LOSS OF DATA, COSTS OF SUBSTITUANTS, CLAIMS BY THIRD PARTIES, OR OTHERWISE.

NO SALESMAN, EMPLOYEE OR AGENT OF SCHNEIDER ELECTRIC IS AUTHORIZED TO ADD TO OR VARY THE TERMS OF THIS WARRANTY. WARRANTY TERMS MAY BE MODIFIED, IF AT ALL, ONLY IN WRITING SIGNED BY AN SCHNEIDER ELECTRIC OFFICER AND LEGAL DEPARTMENT.

Warranty Claims

Customers with warranty claims issues may access the SCHNEIDER ELECTRIC worldwide customer support network through the SCHNEIDER ELECTRIC web site: <http://www.schneider-electric.com>. Select your country from the country selection pull-down menu. Open the Support tab at the top of the web page to obtain contact information for customer support in your region.

Schneider Electric
35 rue Joseph Monier
92500 Rueil Malmaison
France

+ 33 (0) 1 41 29 70 00



As standards, specifications, and design change from time to time,
please ask for confirmation of the information given in this publication.

© 2016 – 2020 Schneider Electric. All rights reserved.

990-5850F-001