



ecodan

# Cylinder unit

## **EHPT20X-MHEDW**

INSTALLATION MANUAL

FOR INSTALLER

English

# Contents

For safe and correct use, read this manual and the outdoor unit installation manual thoroughly before installing the cylinder unit. English is the original language. The other language versions are translations of the original.

- 1. Safety Notices..... 2
- 2. Introduction..... 3
- 3. Technical Information ..... 4
- 4. Installation..... 8
  - 4.1 Location ..... 8
  - 4.2 Water Quality and System Preparation ..... 9
  - 4.3 Water Pipe Work..... 9
  - 4.4 Safety Device Discharge Arrangements (G3)..... 13
  - 4.5 Electrical Connection ..... 14
- 5. System Set Up ..... 16
  - 5.1 DIP Switch Functions ..... 16
  - 5.2 Connecting inputs/outputs ..... 17
  - 5.3 Wiring for 2-zone temperature control ..... 18
  - 5.4 Indoor unit only operation (during installation work) ..... 19
  - 5.5 Smart grid ready ..... 19
  - 5.6 Using SD memory card ..... 19
  - 5.7 Main remote controller ..... 20
- 6. Commissioning..... 26
- 7. Service and Maintenance..... 27



<http://www.mitsubishielectric.com/ldg/ibim/>

If you want more information that is not written in this manual, go to the above website to download manuals, select model name, then choose language.

- Contents of website manual
- Energy monitor
  - Component parts (detail)
  - Water circuit diagram (170 L)
  - Room thermostat
  - Filling the system
  - Simple 2 zone system
  - Independent electrical power source
  - Smart grid ready
  - Remote controller options
  - Service menu (special setting)
  - Supplementary information

en

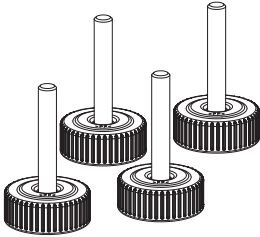
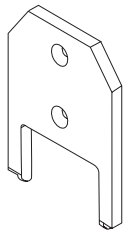
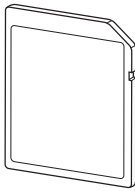
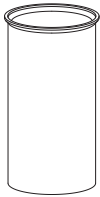
Accessories (Included)			
Adjustable feet	Immersion heater boss tool EHPT20X-MHEDW model only	SD memory card	Copper liner for DHW pipe
			
4	1	1	2

## Abbreviations and glossary

No.	Abbreviations/Word	Description
1	Compensation curve mode	Space heating incorporating outdoor ambient temperature compensation
2	COP	Coefficient of Performance the efficiency of the heat pump
3	Cylinder unit	Indoor unvented DHW tank and component plumbing parts
4	DHW mode	Domestic hot water heating mode for showers, sinks, etc
5	Flow temperature	Temperature at which water is delivered to the primary circuit
6	Freeze stat. function	Heating control routine to prevent water pipes freezing
7	FTC	Flow temperature controller, the circuit board in charge of controlling the system
8	Heating mode	Space heating through radiators or Underfloor heating
9	Legionella	Bacteria potentially found in plumbing, showers and water tanks that may cause Legionnaires disease
10	LP mode	Legionella prevention mode – a function on systems with water tanks to prevent the growth of legionella bacteria
11	Packaged model	Plate heat exchanger (Refrigerant - Water) in the outdoor heat pump unit
12	PRV	Pressure relief valve
13	Return temperature	Temperature at which water is delivered from the primary circuit
14	Split model	Plate heat exchanger (Refrigerant - Water) in the indoor unit
15	TRV	Thermostatic radiator valve – a valve on the entrance or exit of the radiator panel to control the heat output
16	Cooling mode	Space cooling through fan-coils or underfloor cooling

# 1 Safety Notices

Please read the following safety precautions carefully.

**⚠ WARNING:**  
Precautions that must be observed to prevent injuries or death.





**⚠ CAUTION:**  
Precautions that must be observed to prevent damage to unit.

**This installation manual along with the user manual should be left with the product after installation for future reference.**

**Mitsubishi Electric is not responsible for the failure of locally-supplied parts.**

- Be sure to perform periodical maintenance.
- Be sure to follow your local regulations.
- Be sure to follow the instructions provided in this manual.

## MEANINGS OF SYMBOLS DISPLAYED ON THE UNIT

	<b>WARNING</b> (Risk of fire)	This mark is for R32 refrigerant only. Refrigerant type is written on nameplate of outdoor unit. In case that refrigerant type is R32, this unit uses a flammable refrigerant. If refrigerant leaks and comes in contact with fire or heating part, it will create harmful gas and there is risk of fire.
		Read the OPERATION MANUAL carefully before operation.
		Service personnel are required to carefully read the OPERATION MANUAL and INSTALLATION MANUAL before operation.
		Further information is available in the OPERATION MANUAL, INSTALLATION MANUAL, and the likes.

en

### ⚠ ⚠ WARNING

#### Mechanical

The cylinder unit and outdoor unit must not be installed, disassembled, relocated, altered or repaired by the user. Ask an authorised installer or technician. If the unit is installed improperly or modified after installation, water leakage, electric shock or fire may result.

The outdoor unit should be securely fixed to a hard level surface capable of bearing its weight.

The cylinder unit should be positioned on a hard level surface capable of supporting its filled weight to prevent excessive sound or vibration.

Do not position furniture or electrical appliances below the outdoor unit or cylinder unit.

The discharge pipework from the emergency devices of the cylinder unit should be installed according to local law.

Only use accessories and replacement parts authorised by Mitsubishi Electric ask a qualified technician to fit the parts.

#### Electrical

All electrical work should be performed by a qualified technician according to local regulations and the instructions given in this manual.

The units must be powered by a dedicated power supply and the correct voltage and circuit breakers must be used.

Wiring should be in accordance with national wiring regulations. Connections must be made securely and without tension on the terminals.

Earth unit correctly.

#### General

Keep children and pets away from both the cylinder unit and outdoor unit.

Do not use the hot water produced by the heat pump directly for drinking or cooking. This could cause illness to the user.

Do not stand on the units.

Do not touch switches with wet hands.

Annual maintenance checks on both the cylinder unit and the outdoor unit should be conducted by a qualified person.

Do not place containers with liquids on top of the cylinder unit. If they leak or spill onto the cylinder unit damage to the unit and/or fire could occur.

Do not place any heavy items on top of the cylinder unit.

When installing, relocating, or servicing the cylinder unit, use only the heat pump's specified refrigerant to charge the refrigerant lines. Do not mix it with any other refrigerant and do not allow air to remain in the lines. If air is mixed with the refrigerant, then it can be the cause of abnormal high pressure in the refrigerant line, and may result in an explosion and other hazards.

The use of any refrigerant other than that specified for the system will cause mechanical failure or system malfunction or unit breakdown. In the worst case, this could lead to a serious impediment to securing product safety.

In heating mode, to avoid the heat emitters being damaged by excessively hot water, set the target flow temperature to a minimum of 2°C below the maximum allowable temperature of all the heat emitters. For Zone2, set the target flow temperature to a minimum of 5°C below the maximum allowable flow temperature of all the heat emitters in Zone2 circuit.

Do not install the unit where combustible gases may leak, be produced, flow, or accumulate. If combustible gas accumulates around the unit, fire or explosion may result.

Do not use means to accelerate the defrosting process or to clean, other than those recommended by the manufacturer.

The appliance shall be stored in a room without continuously operating ignition sources (for example: open flames, an operating gas appliance or an operating electric heater).

Do not pierce or burn.

Be aware that refrigerants may not contain an odour.

Pipe-work shall be protected from physical damage.

The installation of pipe-work shall be kept to a minimum.

Compliance with national gas regulations shall be observed.

Keep any required ventilation openings clear of obstruction.

Do not use low temperature solder alloy in case of brazing the refrigerant pipes.

# 1 Safety Notices

## ⚠ CAUTION

Use clean water that meets local quality standards on the primary circuit.

The outdoor unit should be installed in an area with sufficient airflow according to the diagrams in the outdoor unit installation manual.

The cylinder unit should be located inside to minimise heat loss.

Water pipe-runs on the primary circuit between outdoor and indoor unit should be kept to a minimum to reduce heat loss.

Ensure condensate from outdoor unit is piped away from the base to avoid puddles of water.

Remove as much air as possible from the primary and DHW circuits.

Refrigerant leakage may cause suffocation. Provide ventilation in accordance with EN378-1.

Be sure to wrap insulation around the piping. Direct contact with the bare piping may result in burns or frostbite.

Never put batteries in your mouth for any reason to avoid accidental ingestion.

Battery ingestion may cause choking and/or poisoning.

Do not transport the cylinder unit with water inside the DHW tank. This could cause damage to the unit.

If power to the cylinder unit is to be turned off (or system switched off) for a long time, the water should be drained.

If unused for a long period, before operation is resumed, DHW tank should be flushed through with potable water.

Preventative measures should be taken against water hammer, such as installing a Water Hammer Arrestor on the primary water circuit, as directed by the manufacturer.

As for the handling of refrigerant, refer to the outdoor unit installation manual.

en

# 2 Introduction

The purpose of this installation manual is to instruct competent persons how to safely and efficiently install and commission the cylinder unit system. The target readers of this manual are competent plumbers and/or refrigeration engineers

who have attended and passed the requisite Mitsubishi Electric product training and have appropriate qualifications for installation of an unvented hot water cylinder unit specific to their country.

### 3 Technical Information

#### Product specification

Model name		EHPT20X-MHEDW	
Nominal domestic hot water volume		200 L	
Overall unit dimensions (Height × Width × Depth)		1600 × 595 × 680 mm	
Weight (empty)		94 kg	
Weight (full)		300 kg	
Water volume of heating circuit in the unit *1		3.7 L	
Unvented expansion vessel (Primary heating)		Nominal volume	—
		Charge pressure	—
Safety device	Primary circuit	Control thermistor	80°C
		Pressure relief valve	0.3 MPa (3bar)
		Flow sensor	Min. flow 5.0 L/min (See table 4.3.1 about water flow rate range)
	Booster heater	BH manual reset thermostat	—
		BH thermal Cut Off	—
	DHW tank	Control thermistor	75°C
IH manual reset thermostat		—	
Temperature/ Pressure relief valve		90°C / 0.7 MPa (7 bar)	
Connections	Water	Primary circuit)	ø28 mm
		DHW circuit	ø22 mm
	Refrigerant (R32/ R410A)	Liquid	—
		Gas	—
Operating range	Heating	Room temperature	10 - 30°C
		Flow temperature	20 - 60°C
	Cooling	Room temperature	—
		Flow temperature	—
Guaranteed operating range *2	Ambient		0 - 35°C (≤ 80 %RH)
	Outdoor temperature	Heating	See outdoor unit spec table.
		Cooling	—
DHW tank performance	Maximum allowable hot water temperature		70°C
	Declared load profile		L
	Average climate	Water heater energy efficiency class	A+
	Time to reheat 70% of DHW tank to 65°C *4		24.8 min
	Time to raise DHW tank temp. 15 - 65°C *4		29.5 min
Electrical data	Control board (Including 4 pumps)	Power supply (Phase, voltage, frequency)	~/N, 230 V, 50 Hz
		Input	0.30 kW
		Current	1.95 A
		Breaker	10 A
	Booster heater	Power supply (Phase, voltage, frequency)	—
		Capacity	—
		Breaker	—
	Immersion heater *3	Power supply (Phase, voltage, frequency)	~/N, 230 V, 50 Hz
		Capacity	3 kW
		Current	13 A
Breaker		16 A	
Sound power level (PWL)		40 dB(A)	

<Table 3.1>

\*1 Volume of sanitary water circuit, primary DHW circuit (from 3-way valve to confluent point with heating circuit), piping to expansion vessel, and expansion vessel are not included in this value.

\*2 The environment must be frost-free.

\*3 Do not fit immersion heaters without thermal cut-out. Use only Mitsubishi Electric service parts as a direct replacement.

\*4 Tested under BS7206 conditions.

### 3 Technical Information

<Unit: mm>

■ Technical Drawings  
 <EHPT20X-MHEDW>  
 (Packaged model system)

en

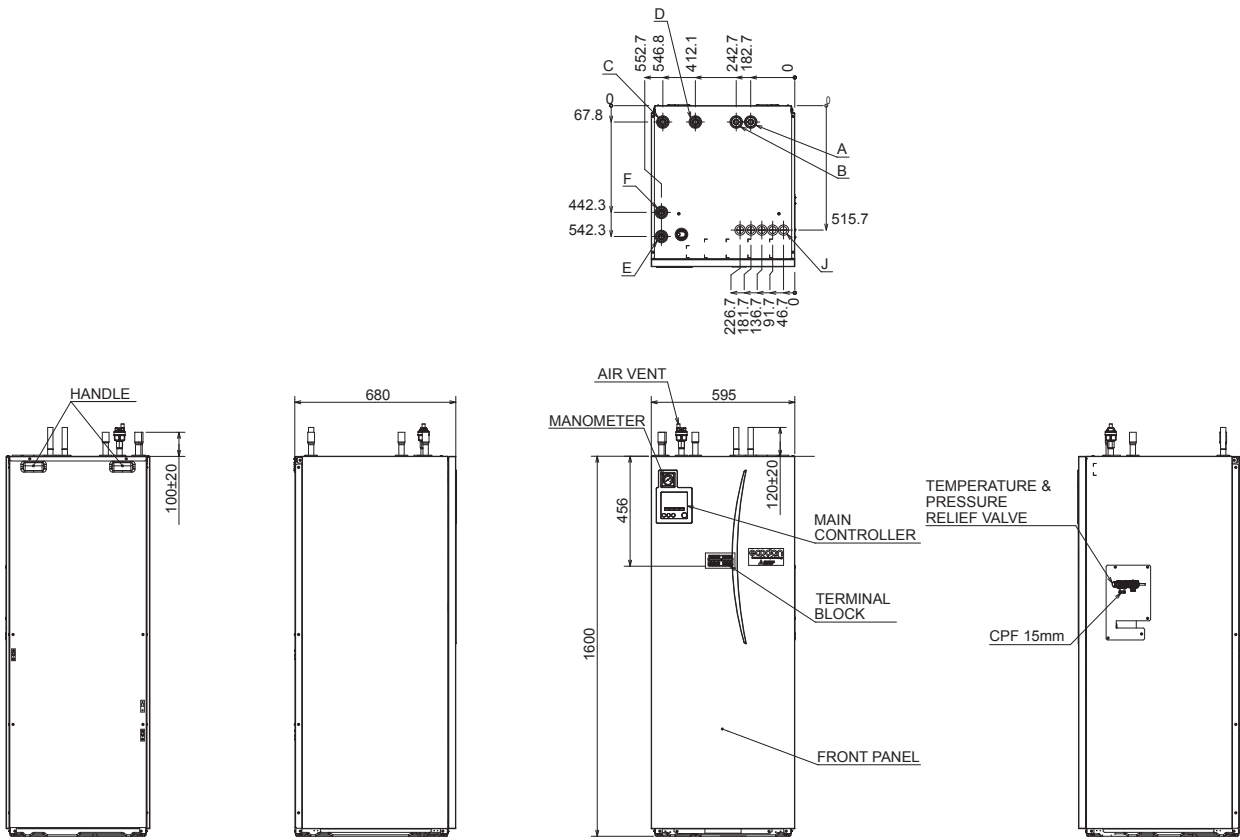

Letter	Pipe description	Connection size/type
A	DHW outlet connection	22 mm/Compression
B	Cold water inlet connection	22 mm/Compression
C	Space heating/cooling RETURN connection	28 mm/Compression
D	Space heating/cooling FLOW connection	28 mm/Compression
E	Flow connection FROM heat pump (No plate heat exchanger)	28 mm/Compression
F	Return connection TO heat pump (No plate heat exchanger)	28 mm/Compression
G	Refrigerant (GAS) (With plate heat exchanger)	12.7 mm/Flare (E*ST**D-*) 15.88 mm/Flare (E*ST**C-*)
H	Refrigerant (LIQUID) (With plate heat exchanger)	6.35 mm/Flare (E*ST**D-*) 9.52 mm/Flare (E*ST**C-*)
J	Electrical cable inlets ① ② ③ ④ ⑤ ○ ○ ○ ○ ○	For inlets ①, ② and ③, run low-voltage wires including external input wires and thermistor wires. For inlets ④ and ⑤, run high-voltage wires including power cable, indoor-outdoor cable, and external output wires. *For a wireless receiver (option) cable and ecodan Wi-Fi interface (option) cable, use inlet ①.

**Warning**

- Refrigerant pipes connection shall be accessible for maintenance purposes.
- In case of reconnecting the refrigerant pipes after detaching, make the flared part of pipe re-fabricated.

<Table 3.2>

# 3 Technical Information

## Component Parts

<EHPT20X-MHEDW>  
(Packaged model system)

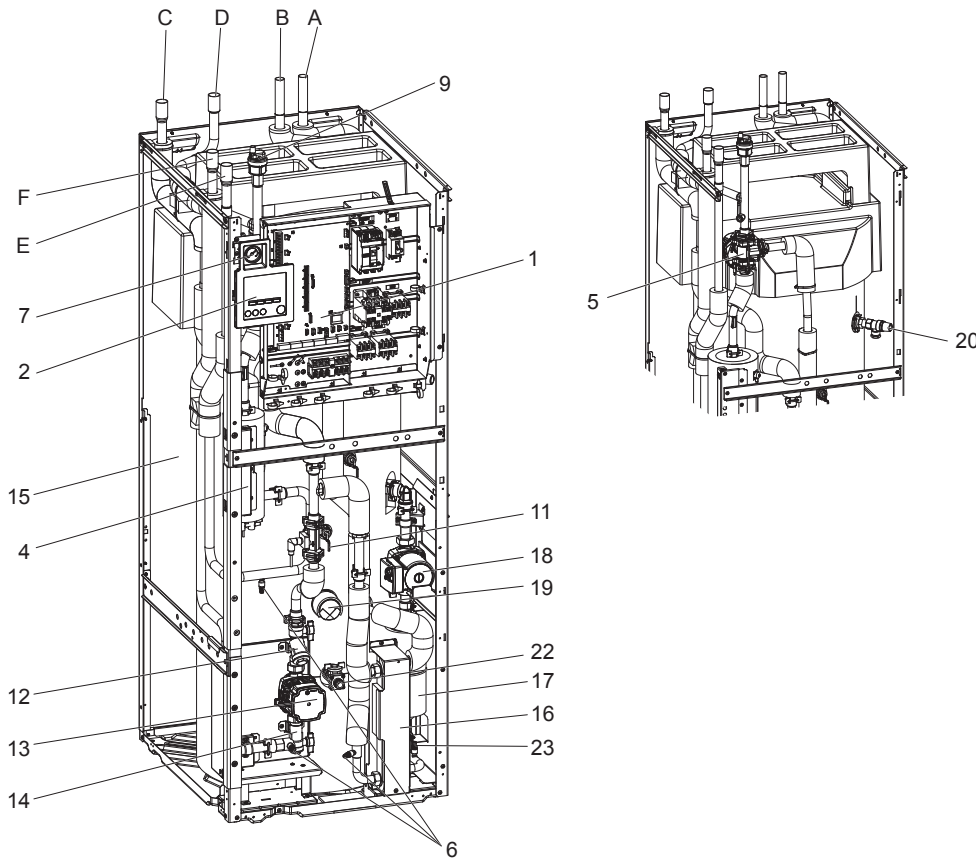

<Figure 3.1>

**Note:**  
For installation of all EHPT20X-MHEDW models, make sure to install a suitably sized primary-side expansion vessel. (See figure 3.2 and 4.3.2 for further guidance)

No.	Part name
A	DHW outlet pipe
B	Cold water inlet pipe
C	Water pipe (Space heating/cooling return connection)
D	Water pipe (Space heating/cooling flow connection)
E	Water pipe (Flow from heat pump connection)
F	Water pipe (Return to heat pump connection)
G	Refrigerant pipe (Gas)
H	Refrigerant pipe (Liquid)
1	Control and electrical box
2	Main remote controller
3	Plate heat exchanger (Refrigerant - Water)
4	Booster heater 1,2
5	3-way valve
6	Drain cock (Primary circuit)
7	Manometer
8	Pressure relief valve (3bar)
9	Automatic air vent
10	Expansion vessel (Primary circuit) (Local supply)
11	Flow sensor
12	Strainer valve
13	Water circulation pump 1 (Primary circuit)
14	Pump valve
15	DHW tank
16	Plate heat exchanger (Water - Water)
17	Scale trap
18	Water circulation pump (Sanitary circuit)
19	Immersion heater
20	Temperature and pressure relief valve
21	Pressure relief valve (10bar) (DHW Tank)
22	Drain cock (DHW tank)
23	Drain cock (Sanitary circuit)
24	Flow water temp. thermistor (THW1)
25	Return water temp. thermistor (THW2)
26	DHW tank upper water temp. thermistor (THW5A)
27	DHW tank lower water temp. thermistor (THW5B)
28	Refrigerant liquid temp. thermistor (TH2)
29	Pressure sensor
30	Drain pan
31	Outdoor unit
32	Drain pipe (Local supply)
33	Back flow prevention device (Local supply)
34	Isolating valve (Local supply)
35	Magnetic filter (Local supply) (Recommended)
36	Strainer (Local supply)
37	Pressure relief valve (Outdoor unit)
38	Inlet control group *1
39	Filling loop (Ball valves, check valves and flexible hose) *1
40	Potable expansion vessel *1
41	Air vent (Local supply)

\*1 Supplied with UK model ONLY. Please refer to PAC-WK02UK-E Installation Manual for more information on accessories.

<Table 3.3>

## Water circuit diagram

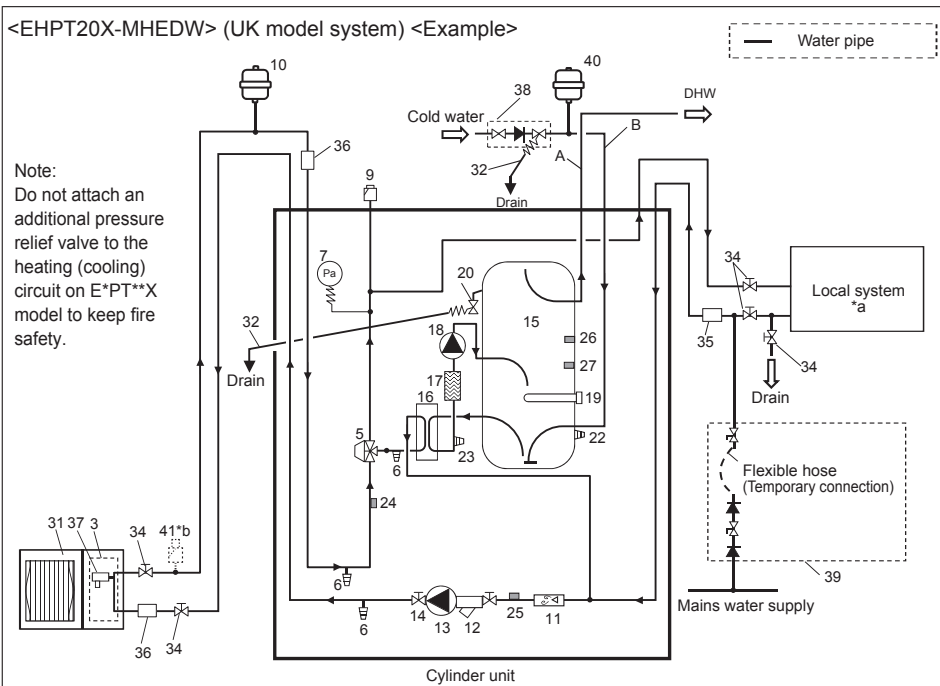

<Figure 3.2>

\*a Refer to the following section 'Local system' on the 'Paper-based manual'.

\*b If the outdoor unit is higher than the indoor unit, or if there is a location where air gets trapped in the upper part of the water pipe, consider adding this part.

- Note (Figure 3.2)**
- To enable draining of the cylinder unit an isolating valve should be positioned on both the inlet and outlet pipework. No valve should be fitted between the expansion valve (item 38) and the cylinder unit (safety matter).
  - For space heating (primary) circuit a suitable expansion vessel **MUST** be supplied and fitted by installer. (See figure 4.3.2)
  - Be sure to install a strainer on the inlet pipework to the cylinder unit.
  - Suitable drain pipework should be attached to the relief valves instructed to be connected to it in Figure 3.2 in accordance with your country's regulations.
  - When using components made from different metals or connecting pipes made of different metals insulate the joints to prevent any corrosive reaction taking place which may damage any pipework.
  - Filling loop's flexible hose must be removed following the filling procedure. Item provided with unit as loose accessory.
  - Install the inlet control group (item 38) above the level of the T&P relief valve (item 20). This will ensure DHW tank will not require drain down to service/maintain the inlet control group.

# 3 Technical Information

## Local system

### 1-zone temperature control

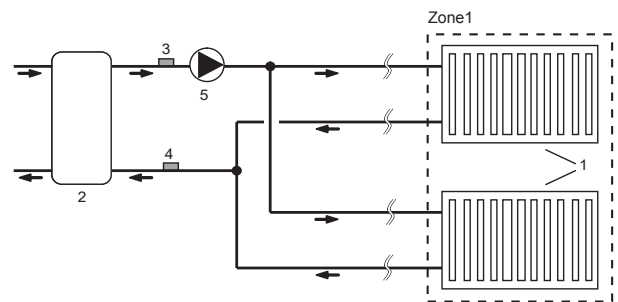
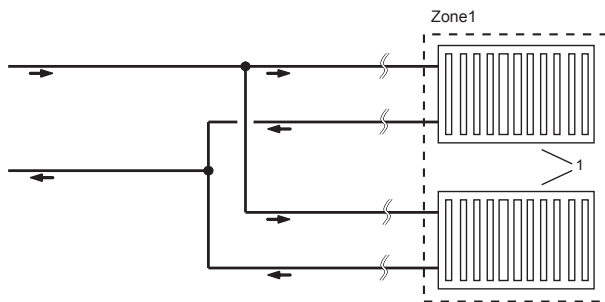

### 2-zone temperature control

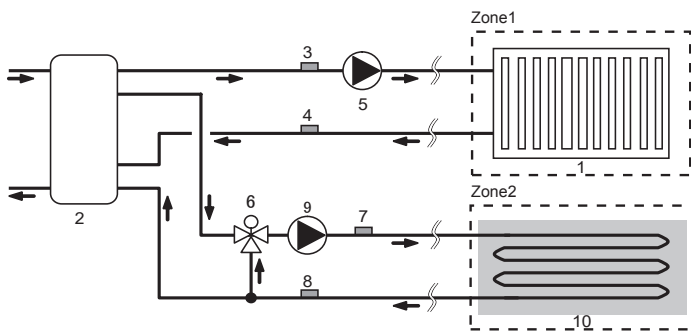

### 1-zone temperature control with boiler

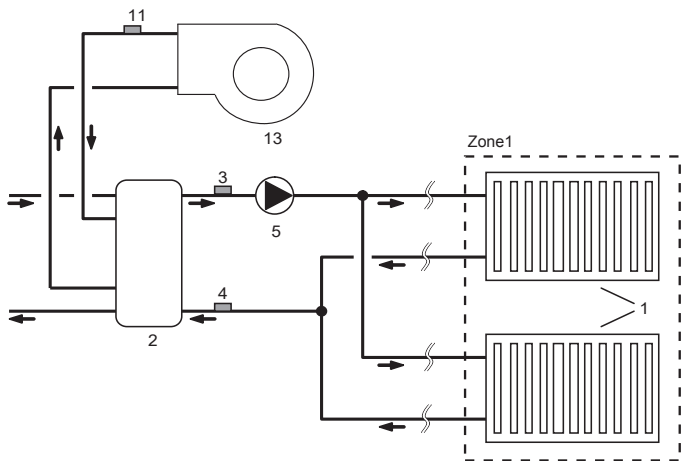

### 2-zone temperature control & Buffer tank control

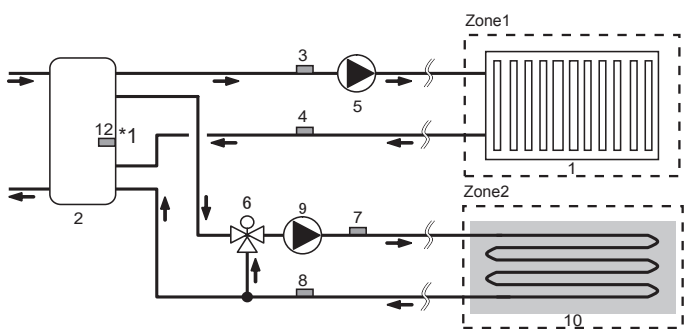

### 1-zone temperature control (2-zone valve ON/OFF control)

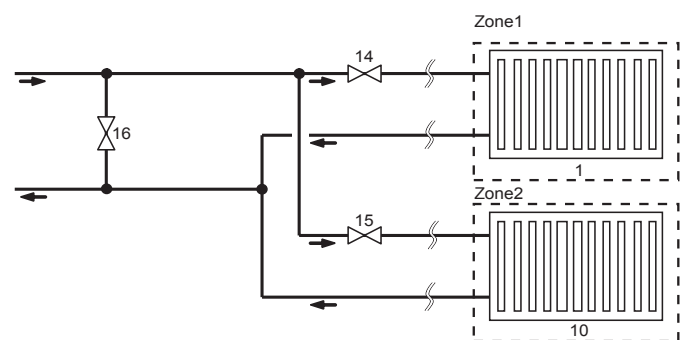

- 1. Zone1 heat emitters (e.g. radiator, fan coil unit) (local supply)
- 2. Mixing tank (local supply)
- 3. Zone1 flow water temp. thermistor (THW6)
- 4. Zone1 return water temp. thermistor (THW7) } Optional part : PAC-TH011-E
- 5. Zone1 water circulation pump (local supply)
- 6. Motorized mixing valve (local supply)
- 7. Zone2 flow water temp. thermistor (THW8)
- 8. Zone2 return water temp. thermistor (THW9) } Optional part : PAC-TH011-E
- 9. Zone2 water circulation pump (local supply)

- 10. Zone2 heat emitters (e.g. underfloor heating) (local supply)
- 11. Boiler flow water temp. thermistor (THWB1) } Optional part : PAC-TH012HT(L)-E
- 12. Mixing tank thermistor (THW10) \*1
- 13. Boiler (local supply)
- 14. Zone1 2-way valve (local supply)
- 15. Zone2 2-way valve (local supply)
- 16. Bypass valve (local supply)

\*1 ONLY Buffer tank control (heating/cooling) applies to "Smart grid ready".

en

# 4 Installation

## <Preparation before the installation and service>

- Prepare the proper tools.
- Prepare the proper protection.
- Allow parts to cool before attempting any maintenance.
- Provide adequate ventilation.
- After stopping the operation of the system, turn off the power-supply breaker and remove the power plug.
- Discharge the capacitor before commencing work involving the electric parts.

## <Precautions during service>

- Do not perform work involving electric parts with wet hands.
- Do not pour water or liquid into the electric parts.
- Do not touch the refrigerant.
- Do not touch the hot or cold surfaces in the refrigerant cycle.
- When the repair or the inspection of the circuit needs to be carried out without turning off the power, exercise great caution NOT to touch any LIVE parts.

## 4.1 Location

### ■ Transportation and Handling

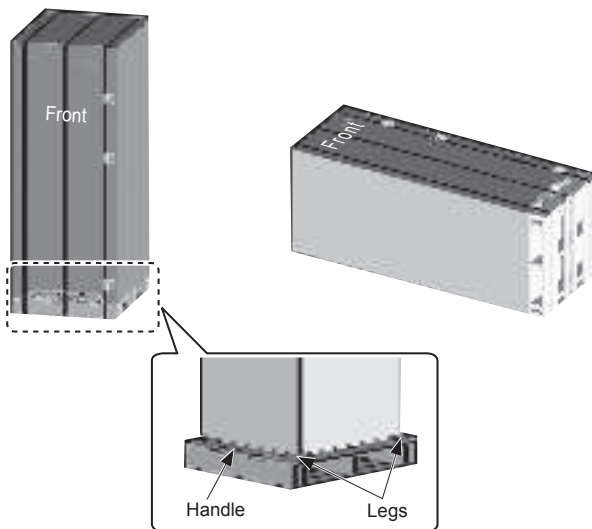

<Figure 4.1.1>

Cylinder unit is delivered on a wooden pallet base with cardboard protection.

Care should be taken when transporting the cylinder unit that the casing is not damaged by impact. Do not remove the protective packaging until cylinder unit has reached its final location. This will help protect the structure and control panel.

- The cylinder unit can be transported either vertically or horizontally. If transported horizontally the panel marked 'Front' must be facing **UPWARDS** <Figure 4.1.1>.
- The cylinder unit should **ALWAYS** be moved by a minimum of 3 people.
- When carrying the cylinder unit use the handles provided.
- Before using the handles, make sure they are securely attached.
- **Please remove front handle, fixing legs, wooden base and any other packaging once the unit is in installation location.**
- **Keep the handles for future transportation.**

### ■ Suitable Location

Before installation the cylinder unit should be stored in a frost-free weather-proof location. Units must **NOT** be stacked.

- The cylinder unit should be installed indoors in a frost free weather proof location.
- Install the cylinder unit where it is not exposed to water/excessive moisture.
- The cylinder unit should be positioned on a level surface capable of supporting it's **FILLED** weight. (Adjustable feet (accessory parts) can be used to ensure unit is level)
- When using the adjustable feet, ensure that the floor is strong enough.
- Care should be taken that minimum distances around and in front of the unit for service access are observed <Figure 4.1.2>.
- Secure the cylinder unit to prevent it being knocked over.

### ■ Service access diagrams

Service access	
Parameter	Dimension (mm)
a	300*
b	150
c (distance behind unit not visible in Figure 4.1.2)	10
d	500

<Table 4.1.1>

Sufficient space **MUST** be left for the provision of discharge pipework as detailed in National and Local Building Regulations.

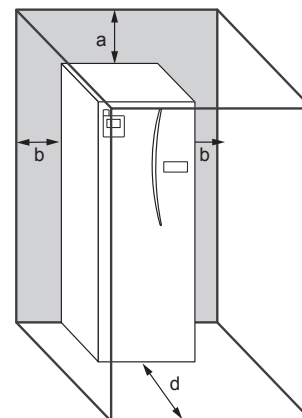

<Figure 4.1.2>

Service access

\* An additional 300 mm of space (total 600 mm) is required, when installing the optional 2-zone kit (PAC-TZ02-E) on top of the cylinder unit.

The cylinder unit must be located indoors and in a frost-free environment, for example in a utility room, to minimise heat loss from stored water.

### ■ Repositioning

If you need to move the cylinder unit to a new position **FULLY DRAIN** the cylinder unit before moving to avoid damage to the unit.

## 4 Installation

### 4.2 Water Quality and System Preparation

#### ■ General

- The water in both primary and sanitary circuit should be clean and with pH value of 6.5-8.0
- The followings are the maximum values;
  - Calcium: 100 mg/L, Ca hardness: 250 mg/L
  - Chloride: 100 mg/L, Copper: 0.3 mg/L
- Other constituents should be to European Directive 98/83 EC standards.
- In known hard water areas, to prevent/minimise scaling, it is beneficial to restrict the routine stored water temperature (DHW max. temp.) to 55°C.

#### ■ Anti-Freeze

Anti-freeze solutions should use propylene glycol with a toxicity rating of Class 1 as listed in Clinical Toxicology of Commercial Products, 5th Edition.

##### Notes:

- Ethylene glycol is toxic and should NOT be used in the primary water circuit in case of any cross-contamination of the potable circuit.
- For 2-zone valve ON/OFF control, propylene glycol should be used.

#### ■ New Installation (primary water circuit)

- Before connecting outdoor unit, thoroughly cleanse pipework of building debris, solder etc using a suitable chemical cleansing agent.
- Flush the system to remove chemical cleanser.
- For all packaged model systems add a combined inhibitor and anti-freeze solution to prevent damage to the pipework and system components.
- For split model systems the responsible installer should decide if anti-freeze solution is necessary for each site's conditions. Corrosion inhibitor however should ALWAYS be used.

#### ■ Existing Installation (primary water circuit)

- Before connecting outdoor unit the existing heating circuit MUST be chemically cleansed to remove existing debris from the heating circuit.
- Flush the system to remove chemical cleanser.
- For all packaged model systems, and the split model or PUMY system without booster heater, add a combined inhibitor and anti-freeze solution to prevent damage to the pipework and system components.
- For split model systems the responsible installer should decide if anti-freeze solution is necessary for each site's conditions. Corrosion inhibitor however should ALWAYS be used.

When using chemical cleansers and inhibitors always follow manufacturer's instructions and ensure the product is appropriate for the materials used in the water circuit

### 4.3 Water Pipe Work

#### ■ Hot Water Pipework

The cylinder unit is UNVENTED. When installing unvented hot water systems building regulations part G3 (England and Wales), P3 (Scotland) and P5 (Northern Ireland) should be adhered to. If outside of the UK please adhere to your own country's regulations for unvented hot water systems.

Connect the flow for the DHW to pipe A (Figure 3.1).

The function of the following safety components of the cylinder unit should be checked on installation for any abnormalities;

- Pressure relief valve (Primary circuit and Tank)
- Expansion vessel pre-charge (gas charge pressure)

The instruction on the following pages regarding safe discharge of hot water from Safety devices should be followed carefully.

- The pipework will become very hot, so should be insulated to prevent burns.
- When connecting pipework, ensure that no foreign objects such as debris or the like enter the pipe.

#### ■ Cold Water Pipework

Cold water to the suitable standard (see section 4.2) should be introduced to the system by connecting pipe B (Figure 3.1) using appropriate fittings.

### ■ Minimum amount of water required in the space heating/cooling circuit

Outdoor heat pump unit	Indoor unit containing water amount [L]	*Additional required water amount [L]			
		Average / Warmer climate**		Colder climate**	
		With booster heater	Without booster heater		
Packaged model	PUZ-WM50	5	0	2	24
	PUZ-WM60		1	4	29
	PUZ-WM85		4	7	32
	PUZ-WM112		8	11	43
	PUZ-HWM140		12	15	55
Split model	SUZ-SWM40	5	0	1	12
	SUZ-SWM60		0	2	21
	SUZ-SWM80		1	4	29
	PUD-S(H)WM60		1	4	21
	PUD-S(H)WM80		4	6	29
	PUD-S(H)WM100		6	10	38
	PUD-S(H)WM120		9	12	47
	PUD-SHW140		12	15	55
	PUHZ-FRP71		11	6	27
	PUHZ-SW75		3	6	37
	PUHZ-SW100		6	9	38
	PUHZ-SW120		9	12	47
	PUHZ-SHW80		4	6	29
	PUHZ-SHW112		8	11	43
	PUHZ-SHW140		12	15	55
	PUMY-P112		22	-	75
	PUMY-P125		22	-	75
PUMY-P140	22	-	75		

<Table 4.2.1>

\* If there is a bypass circuit, above table means minimum water amount in case of bypass.

\*\* Please refer to 2009/125/EC: Energy-related Products Directive and Regulation (EU) No 813/2013 to confirm your climate zone.

Case 1. No division between primary and secondary circuit

- Please ensure the required water amount according to the table 4.2.1 by water pipe and radiator or underfloor heating.

Case 2. Separate primary and secondary circuit

- If the interlock operation of primary and secondary pump is not available, please ensure required additional water in only primary circuit according to the table 4.2.1.
- If the interlock operation of primary and secondary pump is available, please ensure total water amount of primary and secondary circuit according to the table 4.2.1.

In case of the shortage of required water amount, please install buffer tank.

#### ■ Negative pressure prevention

To prevent negative pressure affecting DHW tank, installer should install appropriate pipework or use appropriate devices.

#### ■ Hydraulic filter work (ONLY E\*PT series)

Install a hydraulic filter or strainer (local supply) at the water intake ("Pipe E" in Fig.3.1)

#### ■ Pipework Connections

Connections to the cylinder unit should be made using the 22 mm or 28 mm compression as appropriate.

When connecting DHW pipes using compression fittings, insert **copper liner for DHW pipe** (accessory parts) into the pipes and tighten them from 0.75 to 1.25 turns.

Do not over-tighten compression fittings as this will lead to deformation of the olive ring and potential leaks.

**Note: Before brazing pipes in the field, protect pipes on the cylinder unit using wet towels etc as "heat shield".**

#### ■ Insulation of Pipework

- All exposed water pipework should be insulated to prevent unnecessary heat loss and condensation. To prevent condensate entering the cylinder unit, the pipework and connections at the top of the cylinder unit should be carefully insulated.
- Cold and hot water pipework should not be run close together where possible, to avoid unwanted heat transfer.
- Pipework between outdoor heat pump unit and cylinder unit should be insulated with suitable pipe insulation material with a thermal conductivity of  $\leq 0.04$  W/m.K.

## 4 Installation

### ■ Drain Pipework (ONLY ER series)

- The optional part 'Drain pan stand' does not need to be set because the drain pan is installed. The drain should be set from the drain socket at left rear of the unit. The drain pipe should be installed to drain condensed water during cooling mode.
- To prevent dirty water from draining directly onto the floor next to cylinder unit, please connect appropriate discharge pipework from the cylinder drain pan.
  - Securely install the drain pipe to prevent leakage from the connection.
  - Securely insulate the drain pipe to prevent water dripping from the locally supplied drain pipe.
  - Install the drain pipe at a down slope of 1/100 or more.
  - Do not place the drain pipe in drain channel where sulphuric gas exists.
  - After installation, check that the drain pipe drains water properly from the outlet of the pipe to suitable discharge location.

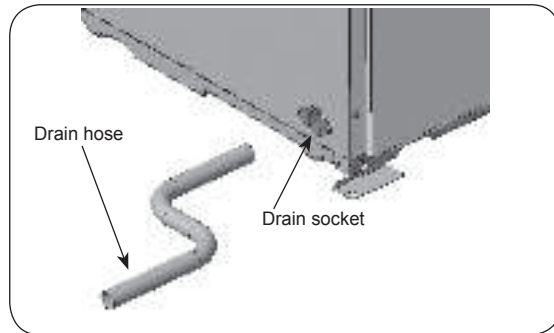

<Figure 4.3.1>

<Installation>

- The drain socket (inside diameter 26mm) is left rear of the cylinder unit. (Figure 4.3.1)
- Fix the drain pipe (VP-20) which fits the drain socket with the polyvinyl chloride type adhesive.
- Set the drain pipework up to the outlet with the down grade of more than one hundredth.

Note: Securely support the locally supplied drain pipe to avoid the drain pipe falling from the drain socket.



### ■ Sizing Expansion Vessels

Expansion vessel volume must fit the local system water volume. To size an expansion vessel for the heating circuit the following formula and graph can be used.

When the necessary expansion vessel volume exceeds the volume of an built-in expansion vessel, install an additional expansion vessel so that the sum of the volumes of the expansion vessels exceeds the necessary expansion vessel volume.

\* For installation of an E\*\*T\*\*\*-M\*ED\* model, provide and install a suitable primary-side expansion vessel and additional 3 bar rated pressure relief valve in the field as the model **DOES NOT** come fitted with a primary-side expansion vessel.

$$V = \frac{\epsilon \times G}{1 - \frac{P_1 + 0.098}{P_2 + 0.098}}$$

Where:

- V : Necessary expansion vessel volume [L]
- $\epsilon$  : Water expansion coefficient
- G : Total volume of water in the system [L]
- P<sub>1</sub> : Expansion vessel setting pressure [MPa]
- P<sub>2</sub> : Max. pressure during operation [MPa]

Graph to the right is for the following values

- $\epsilon$  : at 70°C = 0.0229
- P<sub>1</sub> : 0.1 MPa
- P<sub>2</sub> : 0.3 MPa

\*A 30% safety margin has been added.

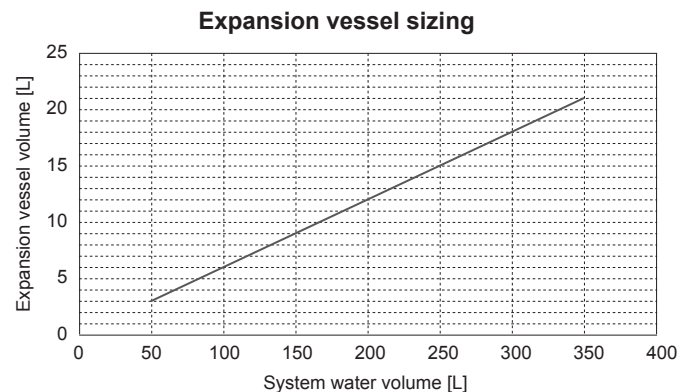

<Figure 4.3.2>

### ■ Filling the System (Primary Circuit)

- Check and charge expansion vessel.
- Check all connections including factory fitted ones are tight.
- Insulate pipework between cylinder unit and outdoor unit.
- Thoroughly clean and flush, system of all debris. (see section 4.2 for instruction.)
- Fill cylinder unit with potable water. Fill primary heating circuit with water and suitable anti-freeze and inhibitor as necessary. **Always use a filling loop with double check valve when filling the primary circuit to avoid back flow contamination of water supply.**
- Check for leakages. If leakage is found, retighten the screws onto the connections.

- Anti-freeze should always be used for packaged model systems (see section 4.2 for instruction). It is the responsibility of the installer to decide if anti-freeze solution should be used in split model systems depending on each site's conditions. Corrosion inhibitor should be used in both split model and packaged model systems. Figure 4.3.3 shows freezing temperature against anti-freeze concentration. This figure is an example for FERNOX ALPHI-11. For other anti-freeze, please refer to relevant manual.
- When connecting metal pipes of different materials insulate the joints to prevent a corrosive reaction taking place which will damage the pipework.

- Pressurise system to 1 bar.
- Release all trapped air using air vents during and following heating period.
- Top up with water as necessary. (If pressure is below 1 bar)
- After removing the air, automatic air vent **MUST** be closed.

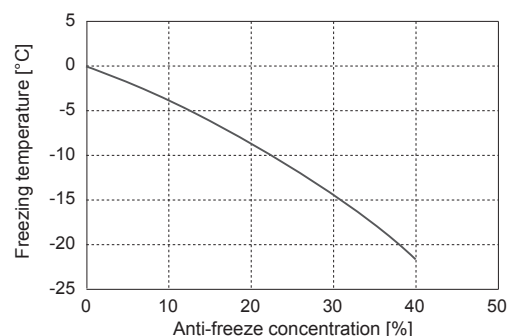

<Figure 4.3.3>

# 4 Installation

## Water Circulation Pump Characteristics

### 1. Primary circuit

Pump speed can be selected by main remote controller setting (see <Figure 4.3.4 to 4.3.8> ).

Adjust the pump speed setting so that the flow rate in the primary circuit is appropriate for the outdoor unit installed (see Table 4.3.1). It may be necessary to add an additional pump to the system depending on the length and lift of the primary circuit.

For outdoor unit model not listed in the <Table 4.3.1>, refer to Water flow rate range in the specification table of outdoor unit Data Book.

### <Second pump >

If a second pump is required for the installation please read the following carefully. If a second pump is used in the system it can be positioned in 2 ways.

The position of the pump influences which terminal of the FTC the signal cable should be wired to. If the additional pump(s) have current greater than 1A please use appropriate relay. Pump signal cable can either be wired to TBO.1 1-2 or CNP1 but NOT both.

### Option 1 (Space heating/cooling only)

If the second pump is being used for the heating circuit only then the signal cable should be wired to TBO.1 terminals 3 and 4 (OUT2). In this position the pump can be run at a different speed to the cylinder unit's in-built pump.

### Option 2 (Primary circuit DHW and space heating/cooling)

If the second pump is being used in the primary circuit between the cylinder unit and the outdoor unit (Package system ONLY) then the signal cable should be wired to TBO.1 terminals 1 and 2 (OUT1). In this position the pump speed **MUST** match the speed of the cylinder unit's in-built pump.

**Note: Refer to 5.2 Connecting inputs/outputs.**

Outdoor heat pump unit		Water flow rate range [L/min]
Packaged model	PUZ-WM50	6.5 - 14.3
	PUZ-WM60	8.6 - 17.2
	PUZ-WM85	10.8 - 24.4
	PUZ-WM112	14.4 - 32.1
	PUZ-HWM140	17.9 - 36.9
Split model	SUZ-SWM40	6.5 - 11.4
	SUZ-SWM60	7.2 - 17.2
	SUZ-SWM80	7.8 - 21.5
	PUD-S(H)WM60	9.0 - 22.9
	PUD-S(H)WM80	9.0 - 22.9
	PUD-S(H)WM100	14.3 - 34.4
	PUD-S(H)WM120	14.3 - 34.4
	PUD-SHW140	14.3 - 34.4
	PUHZ-FRP71	11.5 - 22.9
	PUHZ-SW75	10.2 - 22.9
	PUHZ-SW100	14.4 - 32.1
	PUHZ-SW120	20.1 - 36.9
	PUHZ-SHW80	10.2 - 22.9
	PUHZ-SHW112	14.4 - 32.1
	PUHZ-SHW140	17.9 - 36.9
	PUMY-P112	17.9 - 35.8
	PUMY-P125	17.9 - 35.8
PUMY-P140	17.9 - 35.8	

<Table 4.3.1>

\* If the water flow rate is less than the minimum flow rate setting of the flow sensor (default 5.0 L/min), the flow rate error will be activated. If the water flow rate exceeds 36.9 L/min (E\*\*T20/30 series) or 25.8 L/min (E\*\*T17 series), the flow speed will be greater than 2.0 m/s, which could erode the pipes.

### 2. Sanitary circuit

Default setting: Speed 2

DHW circulation pump **MUST** be set to speed 2.

## Water circulation pump characteristics

### E\*PT17X series

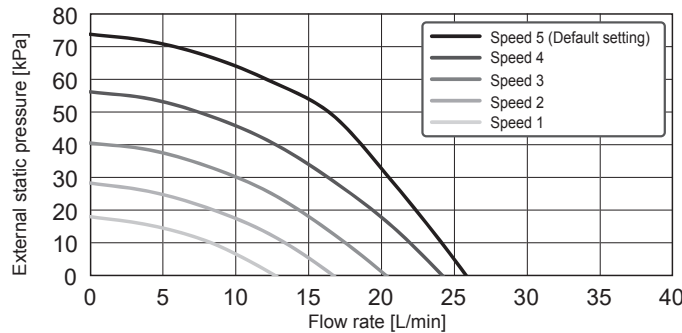

<Figure 4.3.4>

### E\*PT20/30X series

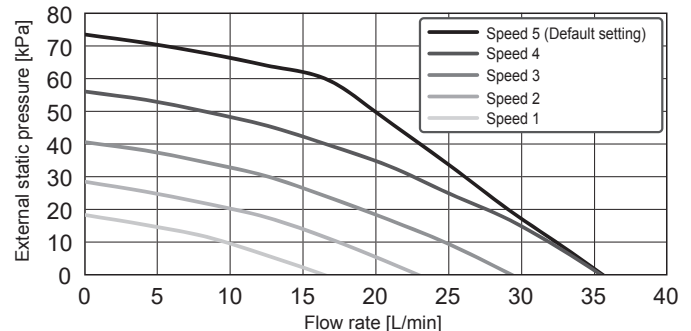

<Figure 4.3.5>

### E\*ST17/20D series

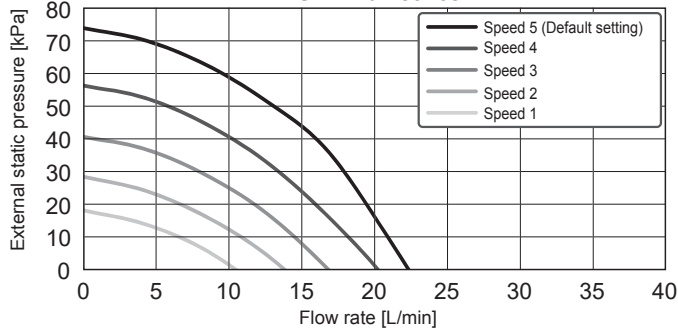

<Figure 4.3.6>

### E\*ST30D series

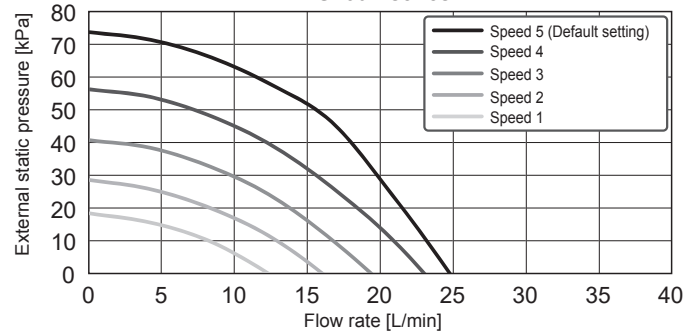

<Figure 4.3.7>

### E\*ST20/30C series

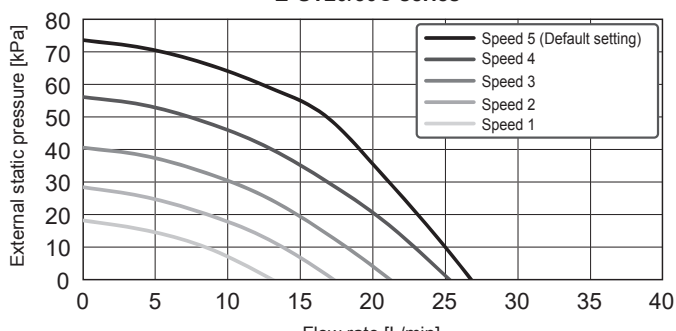

<Figure 4.3.8>

\*For installation of E\*PT series, set its pump speed with a pressure drop between the cylinder unit and the outdoor unit factored into the external static pressure.

## 4 Installation

### ■ Immersion heater

When an immersion heater is fitted, do NOT energise the heater until the DHW tank is full of water. Also do NOT energise any immersion heater if any sterilisation chemicals remain in the DHW tank as this will cause premature failure of the heater.

### ■ Safety Device Connections

The expansion relief valve on the secondary hot water side, and the temperature and pressure (T&P) relief valve (\*A), both need appropriate discharge pipework. There must be no valve fitted between the expansion relief valve and the tank.

\*A EHPT20X-MHEDW is equipped with T & P relief valve on the tank (2). Any other models are equipped with Pressure relief valve, fitted to the DHW pipe-work (3).

**Note : 1. Do not secure the screws excessively when connecting the Discharge pipe, otherwise it may result in damage to the cylinder unit.**

<For UK>

The right side panel has a plate (\*B) so that connection can be made to the factory fitted temperature and pressure relief valve. If you wish to make the connection in a different position you will have to cut a hole in the side panel yourself. However it remains necessary that the drainage parameters outlined in the appropriate Building Regulations are complied with.

\*B Unscrew the plate on the right-side panel, connect the Pressure relief valve to the discharge pipework, and refit the plate. Always replace the plate so that no gaps exist between the plate and side panel and the plate and drain pipe to avoid heat loss.

In accordance with Building Regulations a tundish must be fitted into the pipe-work within 500 mm of the safety device (also see Figure 4.4.1). Due to the distance between the two safety devices it may be necessary to fit each safety device with its own tundish before you run the pipework together to a safe discharge (see Figure 4.3.9).

**Note : 2. Alternatively the discharges from the expansion relief valve and T&P relief valve may commonly discharge to a singular tundish, so long as this tundish is located within 500 mm of the T&P relief valve in UK. When connecting discharge pipes to the safety devices, beware not to strain the inlet connections.**

Diagram part No.	Description	Connection size	Connection type
1	Expansion relief valve (part of inlet control group)	15 mm	Compression
2	T&P relief valve	15 mm /G 1/2	Compression/ Female
3	Pressure relief valve	G 1/2	Female

<Table 4.3.2>

Always refer to local regulations when installing discharge pipework. Install discharge pipework in a frost-free environment. It is necessary to provide appropriate drainage from the pressure relief valve situated on top of the cylinder unit to prevent damage to the unit and the surrounding area from any steam or hot water released. Relief valves MUST NOT be used for any other purpose.

For UK use WK02UK-E kit, for other countries please see below;

- Any discharge pipework should be capable of withstanding discharge of hot water. Discharge pipework should be installed in a continuously downward direction. Discharge pipework must be left open to the environment.

### ■ Piping diagram for 2-zone temperature control

Connect the pipe work and locally supplied parts according to the relevant circuit diagram shown in Section 3. Technical Information, of this manual. For more details on wiring, refer to "5.3 Wiring for 2-zone temperature control".

**Note: Do not install the thermistors on the mixing tank. This could affect correct monitoring of flow and return temperatures through each zone. Install the Zone2 flow temp. thermistor (THW8) near the mixing valve.**

#### <UK model> EHPT20X-MHEDW

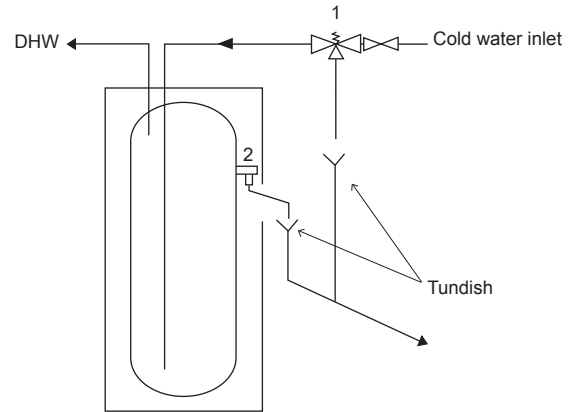

#### <Other models>

The expansion vessel on the sanitary water side shall be installed as necessary in accordance with your local regulations.

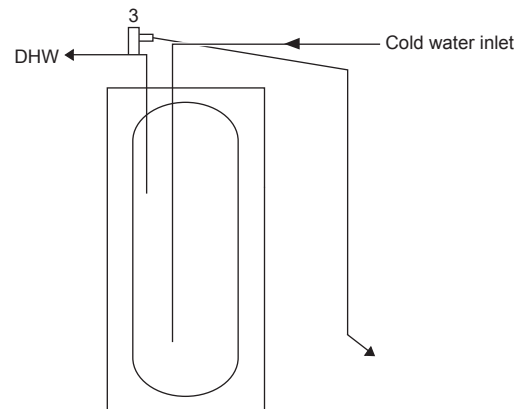

<Figure 4.3.9>

# 4 Installation

## 4.4 Safety Device Discharge Arrangements (G3)

The following instructions are a requirement of UK Building Regulations and must be adhered to. For other countries please refer to local legislation. If you are in any doubt please seek advice from local building planning office.

1. Position the inlet control group so that discharge from both safety valves can be joined together via a 15 mm end feed Tee.
2. Connect the tundish and route the discharge pipe as shown in Figure 4.4.1.
3. The tundish should be fitted vertically and as close to the safety device as possible and within 500 mm of the device.
4. The tundish should be visible to occupants and positioned away from electrical devices.
5. The discharge pipe (D2) from the tundish should terminate in a safe place where there is no risk to persons in the vicinity of the discharge, be of metal construction and:

A) Be at least one pipe size larger than the nominal outlet size of the safety device unless its total equivalent hydraulic resistance exceeds that of a straight pipe 9 m long i.e. discharge pipes between 9 m and 18 m equivalent resistance length should be at least two sizes larger than the nominal outlet size of the safety device, between 18 and 27 m at least 3 sizes larger, and so on. Bends must be taken into account in calculating the flow resistance. Refer to Figure 4.4.1, Table 4.4.1 and the worked example. An alternative approach for sizing discharge pipes would be to follow BS 6700: 1987 specification for design installation, testing and maintenance of services supplying water for domestic use within buildings and their cartilages.

B) Have a vertical section of pipe at least 300 mm long, below the tundish before any elbows or bends in the pipework.

C) Be installed with a continuous fall.

D) Have discharges visible at both the tundish and the final point of discharge but where this is not possible or is practically difficult there should be clear visibility at one or other of these locations. Examples of acceptable discharge arrangements are:

- i. Ideally below a fixed grating and above the water seal in a trapped gully.
- ii. Downward discharges at low level; i.e. up to 100 mm above external surfaces such as car parks, hard standings, grassed areas etc. are acceptable providing that where children may play or otherwise come into contact with discharges a wire cage or similar guard is positioned to prevent contact, whilst maintaining visibility.
- iii. Discharges at high level; e.g. into a metal hopper and metal down pipe with the end of the discharge pipe clearly visible (tundish visible or not) or onto a roof capable of withstanding high temperature discharges of water and 3 m from any plastic guttering system that would collect such discharges (tundish visible).
- iv. Where a single pipe serves a number of discharges, such as in blocks of flats, the number served should be limited to not more than 6 systems so that any installation discharging can be traced reasonably easily. The single common discharge pipe should be at least one pipe size larger than the largest individual discharge pipe (D2) to be connected. If unvented hot water storage systems are installed where discharges from safety devices may not be apparent i.e. in dwellings occupied by blind, infirm or disabled people, consideration should be given to the installation of an electronically operated device to warn when discharge takes place.

**Note:** The discharge will consist of scalding water and steam. Asphalt, roofing felt and nonmetallic rainwater goods may be damaged by such discharges.

**Worked example:** The example below is for a G½ temperature relief valve with a discharge pipe (D2) having 4 No. elbows and length of 7 m from the tundish to the point of discharge.

From Table 4.4.1: Maximum resistance allowed for a straight length of 22 mm copper discharge pipe (D2) from a G½ temperature relief valve is: 9.0 m subtract the resistance for 4 No. 22 mm elbows at 0.8 m each = 3.2 m. Therefore the maximum permitted length equates to: 5.8 m. 5.8 m is less than the actual length of 7 m, therefore calculate the next largest size. Maximum resistance allowed for a straight length of 28 mm pipe (D2) from a G½ temperature relief valve equates to: 18 m  
 Subtract the resistance for 4 No. 28 mm elbows at 1.0 m each = 4 m. Therefore the maximum permitted length equates to: 14 m. As the actual length is 7 m, a 28 mm (D2) copper pipe will be satisfactory.

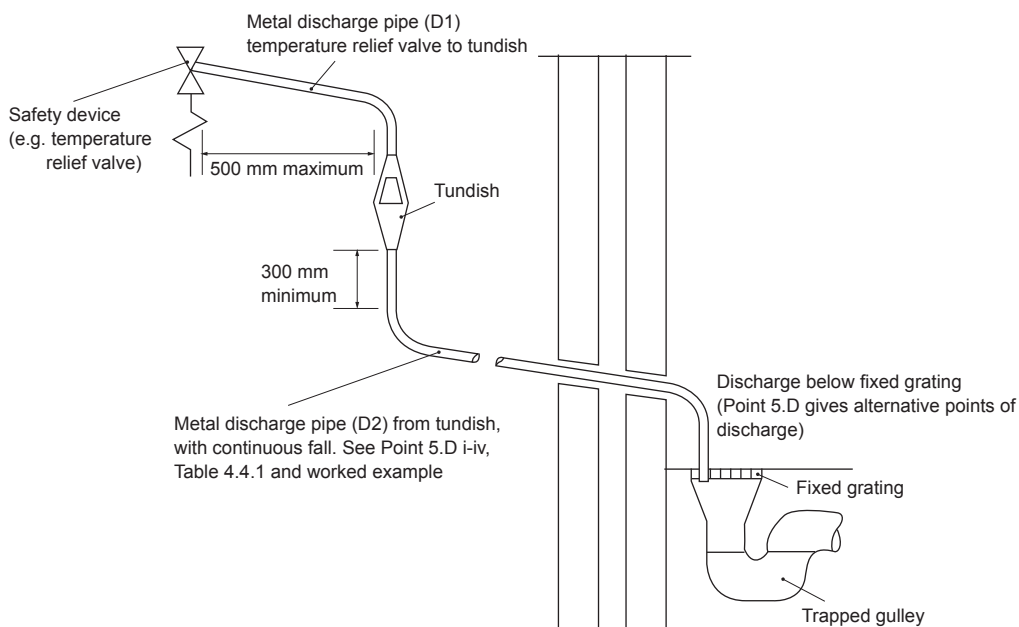

<Figure 4.4.1>

Valve outlet size	Minimum size of discharge pipe D1	Minimum size of discharge pipe D2 from tundish	Maximum resistance allowed, expressed as a length of straight pipe (no elbows or bends)	Resistance created by each elbow or bend
G 1/2	15 mm	22 mm	Up to 9 m	0.8 m
		28 mm	Up to 18 m	1.0 m
		35 mm	Up to 27 m	1.4 m
G 3/4	22 mm	28 mm	Up to 9 m	1.0 m
		35 mm	Up to 18 m	1.4 m
		42 mm	Up to 27 m	1.7 m
G1	28 mm	35 mm	Up to 9 m	1.4 m
		42 mm	Up to 18 m	1.7 m
		54 mm	Up to 27 m	2.3 m

<Table 4.4.1>

# 4 Installation

## 4.5 Electrical Connection

All electrical work should be carried out by a suitably qualified technician. Failure to comply with this could lead to electrocution, fire, and death. It will also invalidate product warranty. All wiring should be according to national wiring regulations.

Breaker abbreviation	Meaning
ECB1	Earth leakage circuit breaker for booster heater
ECB2	Earth leakage circuit breaker for immersion heater
TB1	Terminal block 1

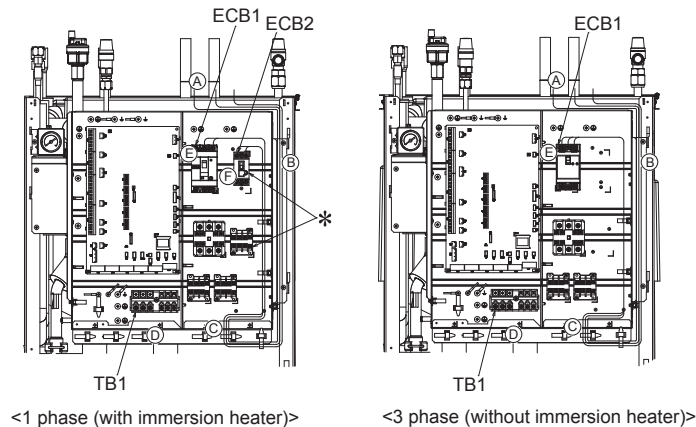

The cylinder unit can be powered in two ways.

1. Power cable is run from the outdoor unit to the cylinder unit.
2. Cylinder unit has independent power source

Connections should be made to the terminals indicated in the figures to the left below depending on the phase.

Booster heater and immersion heater should be connected independently from one another to dedicated power supplies.

- Locally supplied wiring should be inserted through the inlets situated on the top of the cylinder unit. (Refer to <Table 3.2>.)
- Wiring should be fed down the right hand side of the control and electrical box and clamped in place using clips provided.
- The wires should be inserted individually through the cable inlets as below.
  - Outputs wire
  - Indoor-Outdoor wire
  - Power line(B.H.)/ Power line(I.H.)(Option)
  - Signal input wires
- Connect the outdoor unit – cylinder unit connecting cable to TB1.
- Connect the power cable for the booster heater to ECB1.
- If immersion heater is present, connect the power cable to ECB2.

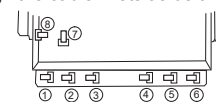

- Avoid contact between wiring and parts (\*).
- Make sure that ECB1 and ECB2 are ON.
- On completion of wiring ensure main remote controller cable is connected to the relay connector.

### Cylinder unit powered via outdoor unit

(If you want to use independent source, go to the Mitsubishi website.)

#### <1 phase>

Affix label A that is included with the manuals near each wiring diagram for cylinder unit and outdoor units.

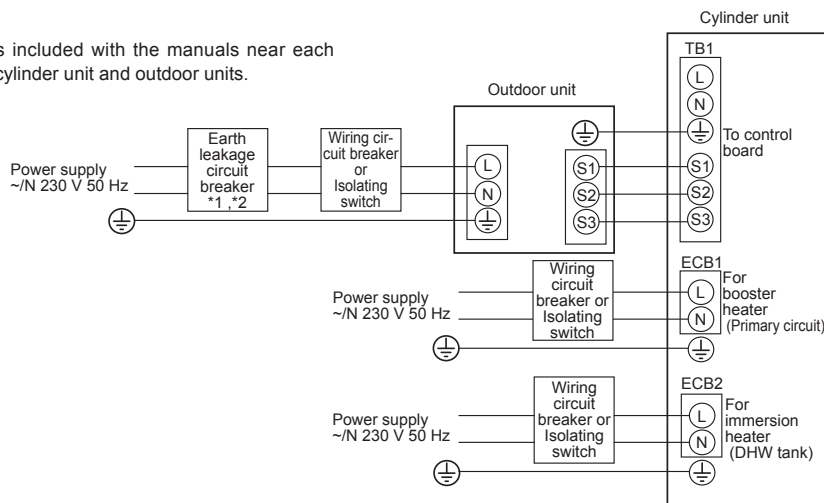

- \*1. If the installed earth leakage circuit breaker does not have an over-current protection function, install a breaker with that function along the same power line.
- \*2. A breaker with at least 3.0 mm contact separation in each pole shall be provided. Use earth leakage breaker (NV). The breaker shall be provided to ensure disconnection of all active phase conductors of the supply.
- \*3. Max. 45 m  
If 2.5 mm<sup>2</sup> used, Max. 50 m  
If 2.5 mm<sup>2</sup> used and S3 separated, Max. 80 m
- \*4. The values given in the table above are not always measured against the ground value.

<Figure 4.5.1>  
Electrical connections 1 phase

Description	Power supply	Capacity	Breaker	Wiring
Booster heater (Primary circuit)	~N 230 V 50 Hz	2 kW	16 A *2	2.5 mm <sup>2</sup>
		6 kW	32 A *2	6.0 mm <sup>2</sup>
Immersion heater (DHW tank)	~N 230 V 50 Hz	3 kW	16 A *2	2.5 mm <sup>2</sup>

Wiring No. x size (mm <sup>2</sup> )	Cylinder unit - Outdoor unit		
	Cylinder unit - Outdoor unit	*3	3 × 1.5 (polar)
Cylinder unit - Outdoor unit earth	*3	1 × Min. 1.5	
Circuit rating	Cylinder unit - Outdoor unit S1 - S2	*4	230 V AC
	Cylinder unit - Outdoor unit S2 - S3	*4	24 V DC

- Notes:
1. Wiring size must comply with the applicable local and national codes.
  2. Indoor unit/outdoor unit connecting cords shall not be lighter than polychloroprene sheathed flexible cord. (Design 60245 IEC 57)  
Indoor unit power supply cords shall not be lighter than polychloroprene sheathed flexible cord. (Design 60227 IEC 53)
  3. Install an earth longer than other cables.
  4. Please keep enough output capacity of power supply for each heater. Insufficient power supply capacity might cause chattering.

# 4 Installation

## <3 phase>

Affix label A that is included with the manuals near each wiring diagram for cylinder unit and outdoor units.

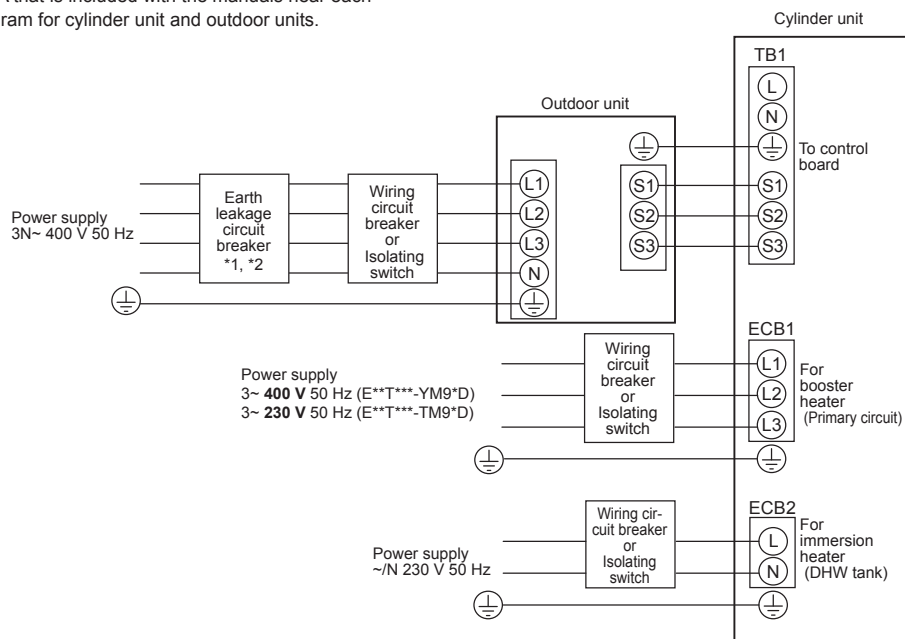

<Figure 4.5.2>  
Electrical connections 3 phase

Description	Power supply	Capacity (Indoor unit Ref.)	Breaker	Wiring
Booster heater (Primary circuit)	3~ 400 V 50 Hz	9 kW	16 A *2	2.5 mm <sup>2</sup>
	3~ 230 V 50 Hz	9 kW	32 A *2	6.0 mm <sup>2</sup>
Immersion heater (DHW tank)	~N 230 V 50 Hz	3 kW	16 A *2	2.5 mm <sup>2</sup>

Wiring No. x size (mm <sup>2</sup> )	Cylinder unit - Outdoor unit	*3	3 × 1.5 (polar)
	Cylinder unit - Outdoor unit earth	*3	1 × Min. 1.5
Circuit rating	Cylinder unit - Outdoor unit S1 - S2	*4	230 V AC
	Cylinder unit - Outdoor unit S2 - S3	*4	24 V DC

- \*1. If the installed earth leakage circuit breaker does not have an over-current protection function, install a breaker with that function along the same power line.
- \*2. A breaker with at least 3.0 mm contact separation in each pole shall be provided. Use earth leakage breaker (NV).  
The breaker shall be provided to ensure disconnection of all active phase conductors of the supply.
- \*3. Max. 45 m  
If 2.5 mm<sup>2</sup> used, Max. 50 m  
If 2.5 mm<sup>2</sup> used and S3 separated, Max. 80 m
- \*4. The values given in the table above are not always measured against the ground value.

- Notes:**
1. Wiring size must comply with the applicable local and national codes.
  2. Indoor unit/outdoor unit connecting cords shall not be lighter than polychloroprene sheathed flexible cord. (Design 60245 IEC 57)  
Indoor unit power supply cords shall not be lighter than polychloroprene sheathed flexible cord. (Design 60227 IEC 53)
  3. Install an earth longer than other cables.
  4. Please keep enough output capacity of power supply for each heater. Insufficient power supply capacity might cause chattering.

# 5 System Set Up

## 5.1 DIP Switch Functions

The DIP switch number is printed on the circuit board next to the relevant switches. The word ON is printed on the circuit board and on the DIP switch block itself. To move the switch you will need to use a pin or the corner of a thin metal ruler or similar.

DIP switch settings are listed below in Table 5.1.1.

Only an authorised installer can change DIP switch setting under one's own responsibility according to the installation condition.

Make sure to turn off both indoor unit and outdoor unit power supplies before changing the switch settings.

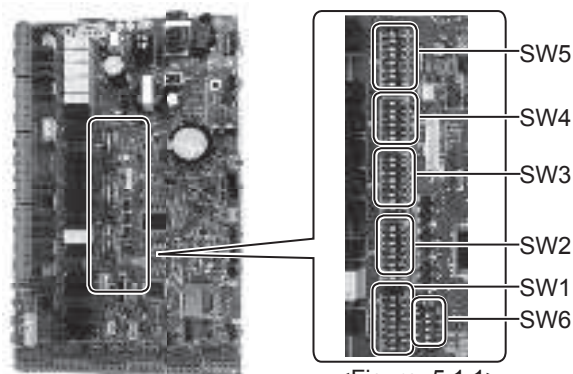

<Figure 5.1.1>

DIP switch	Function	OFF	ON	Default settings: Indoor unit model			
SW1	SW1-1 Boiler	WITHOUT Boiler	WITH Boiler	OFF			
	SW1-2 Heat pump maximum outlet water temperature	55°C	60°C	ON *1			
	SW1-3 DHW tank	WITHOUT DHW tank	WITH DHW tank	ON			
	SW1-4 Immersion heater	WITHOUT Immersion heater	WITH Immersion heater	OFF: Except EHPT20X-MHEDW ON : EHPT20X-MHEDW			
	SW1-5 Booster heater	WITHOUT Booster heater	WITH Booster heater	OFF: E**T***-M**D* ON : E**T***-M 2/6/9*D			
	SW1-6 Booster heater function	For heating only	For heating and DHW	OFF: E**T***-M**D* ON : E**T***-M 2/6/9*D			
	SW1-7 Outdoor unit type	Split type	Packaged type	OFF: E*ST***-M**D* ON : E*PT**X-*M**D*			
	SW1-8 Wireless remote controller	WITHOUT Wireless remote controller	WITH Wireless remote controller	OFF			
SW2	SW2-1 Room thermostat 1 input (IN1) logic change	Zone1 operation stop at thermostat short	Zone1 operation stop at thermostat open	OFF			
	SW2-2 Flow switch 1 input (IN2) logic change	Failure detection at short	Failure detection at open	OFF			
	SW2-3 Booster heater capacity restriction	Inactive	Active	OFF: Except E**T***-VM2*D ON : E**T***-VM2*D			
	SW2-4 Cooling mode function	Inactive	Active	OFF: EH*T***-M**D* ON : ER*T***-M**D			
	SW2-5 Automatic switch to backup heat source operation (When outdoor unit stops by error)	Inactive	Active *2	OFF			
	SW2-6 Mixing tank	WITHOUT Mixing tank	WITH Mixing tank	OFF			
	SW2-7 2-zone temperature control	Inactive	Active *6	OFF			
	SW2-8 Flow sensor	WITHOUT Flow sensor	WITH Flow sensor	ON			
SW3	SW3-1 Room thermostat 2 input (IN6) logic change	Zone2 operation stop at thermostat short	Zone2 operation stop at thermostat open	OFF			
	SW3-2 Flow switch 2 and 3 input logic change	Failure detection at short	Failure detection at open	OFF			
	SW3-3 3-way valve type	AC motor	Stepping motor	OFF: Except E**T17X/17D/20D- *M**D* ON: E**T17X/17D/20D-*M**D			
	SW3-4 Electric energy meter	WITHOUT Electric energy meter	WITH Electric energy meter	OFF			
	SW3-5 Heating mode function *3	Inactive	Active	ON			
	SW3-6 2-zone valve ON/OFF control	Inactive	Active	OFF			
	SW3-7 Heat exchanger for DHW	Coil in tank	External plate HEX	ON			
	SW3-8 Heat meter	WITHOUT Heat meter	WITH Heat meter	OFF			
SW4	SW4-1	—	—	OFF			
	SW4-2	—	—	OFF			
	SW4-3	—	—	OFF			
	SW4-4 Indoor unit only operation (during installation work) *4	Inactive	Active	OFF			
	SW4-5 Emergency mode (Heater only operation)	Normal	Emergency mode (Heater only operation)	OFF *5			
	SW4-6 Emergency mode (Boiler operation)	Normal	Emergency mode (Boiler operation)	OFF *5			
SW5	SW5-1	—	—	OFF			
	SW5-2 Advanced auto adaptation	Inactive	Active	ON			
	SW5-3	Capacity code					
	SW5-4		SW5-3	SW5-4	SW5-5	SW5-6	SW5-7
	SW5-5	E**T**C-*M**D	ON	ON	ON	ON	OFF
	SW5-6	E**T**D-*M**D	ON	OFF	OFF	ON	OFF
	SW5-7	E**T**X-*M**D*	OFF	OFF	OFF	OFF	OFF
	SW5-8	—	—	—	—	—	OFF
	SW6	SW6-1	—	—	OFF		
SW6-2		—	—	OFF			
SW6-3 Pressure sensor		Inactive	Active	OFF: Except E*ST**D-*M**D ON: E*ST**D-*M**D			
SW6-4 Analog output signal (0-10 V)		Inactive	Active	OFF			
SW6-5		—	—	—	OFF		

<Table 5.1.1>

- Notes:**
- \*1. When the cylinder unit is connected with a PUMY-P outdoor unit of which maximum outlet water temperature is 55°C, DIP SW1-2 must be changed to OFF.
  - \*2. External output (OUT11) will be available. For safety reasons, this function is not available for certain errors. (In that case, system operation must be stopped and only the water circulation pump keeps running.)
  - \*3. This switch functions only when the cylinder unit is connected with a PUHZ-FRP outdoor unit. When another type of outdoor unit is connected, the heating mode function is active regardless of the fact that this switch is ON or OFF.
  - \*4. Space heating and DHW can be operated only in indoor unit, like an electric heater. (Refer to "5.4 Indoor unit only operation".)
  - \*5. If emergency mode is no longer required, return the switch to OFF position.
  - \*6. Active only when SW3-6 is set to OFF.

# 5 System Set Up

## 5.2 Connecting inputs/outputs

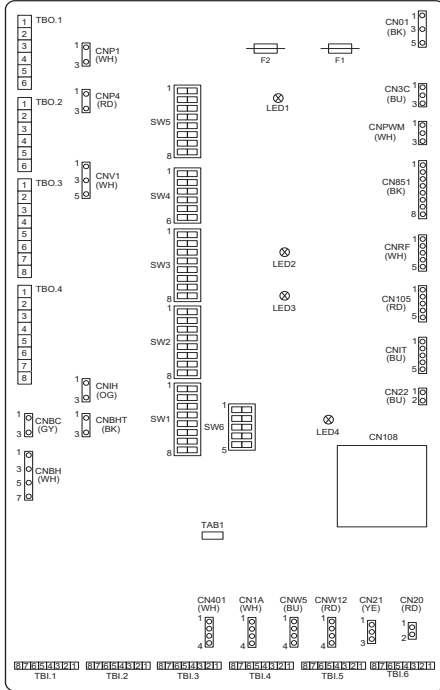

<Figure 5.2.1>

### Wiring specification and local supply parts

Item	Name	Model and specifications
Signal input function	Signal input wire	Use sheathed vinyl coated cord or cable. Max. 30 m Wire type: CV, CVS or equivalent Wire size: Stranded wire 0.13 mm <sup>2</sup> to 0.52 mm <sup>2</sup> Solid wire: ø0.4 mm to ø0.8 mm
	Switch	Non-voltage "a" contact signals Remote switch: minimum applicable load 12 V DC, 1 mA

#### Note:

Stranded wire should be processed with insulation-covered bar terminal (DIN46228-4 standard compatible type).

### Signal inputs

Name	Terminal block	Connector	Item	OFF (Open)	ON (Short)
IN1	TBI.1 7-8	—	Room thermostat 1 input *1	Refer to SW2-1 in <5.1 DIP Switch Functions>.	
IN2	TBI.1 5-6	—	Flow switch 1 input	Refer to SW2-2 in <5.1 DIP Switch Functions>.	
IN3	TBI.1 3-4	—	Flow switch 2 input (Zone1)	Refer to SW3-2 in <5.1 DIP Switch Functions>.	
IN4	TBI.1 1-2	—	Demand control input	Normal	Heat source OFF/ Boiler operation *3
IN5	TBI.2 7-8	—	Outdoor thermostat input *2	Standard operation	Heater operation/ Boiler operation *3
IN6	TBI.2 5-6	—	Room thermostat 2 input *1	Refer to SW3-1 in <5.1 DIP Switch Functions>.	
IN7	TBI.2 3-4	—	Flow switch 3 input (Zone2)	Refer to SW3-2 in <5.1 DIP Switch Functions>.	
IN8	TBI.3 7-8	—	Electric energy meter 1	*4	
IN9	TBI.3 5-6	—	Electric energy meter 2		
IN10	TBI.2 1-2	—	Heat meter		
IN11	TBI.3 3-4	—	Smart grid ready input	*5	
IN12	TBI.3 1-2	—			
INA1	TBI.4 1-3	CN1A	Flow sensor	—	—

\*1. Set the ON/OFF cycle time of the room thermostat for 10 minutes or more; otherwise the compressor may be damaged.

\*2. If using outdoor thermostat for controlling operation of heaters, the lifetime of the heaters and related parts may be reduced.

\*3. To turn on the boiler operation, use the main remote controller to select "Boiler" in "External input setting" screen in the service menu.

\*4. Connectable electric energy meter and heat meter

- Pulse type Voltage free contact for 12 VDC detection by FTC (TBI.2 1pin, TBI.3 5 and 7 pins have a positive voltage.)
- Pulse duration Minimum ON time: 40 ms  
Minimum OFF time: 100 ms
- Possible unit of pulse 0.1 pulse/kWh 1 pulse/kWh 10 pulse/kWh  
100 pulse/kWh 1000 pulse/kWh

Those values can be set by the main remote controller. (Refer to the menu tree in "Main remote controller".)

\*5. As for the SG ready, refer to "5.5 Smart grid ready".

### Thermistor inputs

Name	Terminal block	Connector	Item	Optional part model
TH1	—	CN20	Thermistor (Room temp.) (Option)	PAC-SE41TS-E
TH2	—	CN21	Thermistor (Ref. liquid temp.)	—
THW1	—	CNW12 1-2	Thermistor (Flow water temp.)	—
THW2	—	CNW12 3-4	Thermistor (Return water temp.)	—
THW5A	—	CNW5 1-2	Thermistor (DHW tank upper water temp.)	—
THW5B	—	CNW5 3-4	Thermistor (DHW tank lower water temp.)	—
THW6	TBI.5 7-8	—	Thermistor (Zone1 flow water temp.) (Option) *1	PAC-TH011-E
THW7	TBI.5 5-6	—	Thermistor (Zone1 return water temp.) (Option) *1	
THW8	TBI.5 3-4	—	Thermistor (Zone2 flow water temp.) (Option) *1	PAC-TH011-E
THW9	TBI.5 1-2	—	Thermistor (Zone2 return water temp.) (Option) *1	
THWB1	TBI.6 7-8	—	Thermistor (Boiler flow water temp.) (Option) *1	PAC-TH012HT-E(5 m)/
THW10	TBI.6 5-6	—	Thermistor (Mixing tank water temp.) (Option) *1	PAC-TH012HTL-E(30 m)

Ensure to wire thermistor wirings away from the power line and/or OUT1 to 16 wirings.

\*1. The maximum length of the thermistor wiring is 30 m.

The length of the optional thermistors are 5 m. If you need to splice and extend the wirings, following points must be carried out.

- 1) Connect the wirings by soldering.
- 2) Insulate each connecting point against dust and water. Stranded wire should be processed with insulation-covered bar terminal (DIN46228-4 standard compatible type).

# 5 System Set Up

## Outputs

Name	Terminal block	Connector	Item	OFF	ON	Signal/Max current	Max. total current
OUT1	TBO.1 1-2	CNP1	Water circulation pump 1 output (Space heating/cooling & DHW)	OFF	ON	230 V AC 1.0 A Max. (Inrush current 40 A Max.)	4.0 A (a)
OUT2	TBO.1 3-4	—	Water circulation pump 2 output (Space heating/cooling for Zone1)	OFF	ON	230 V AC 1.0 A Max. (Inrush current 40 A Max.)	
OUT3	TBO.1 5-6	—	Water circulation pump 3 output (Space heating/cooling for Zone2) *1 2-way valve 2b output *2	OFF	ON	230 V AC 1.0 A Max. (Inrush current 40 A Max.)	
OUT14	—	CNP4	Water circulation pump 4 output (DHW)	OFF	ON	230 V AC 1.0 A Max. (Inrush current 40 A Max.)	
OUT4	TBO.2 4-6	CNV1	3-way valve (2-way valve) output	Heating	DHW	230 V AC 0.1 A Max.	3.0 A (b)
	—	CN851	3-way valve output				
OUT5	TBO.2 1-2	—	Mixing valve output *1	Stop	Close	230 V AC 0.1 A Max.	
	TBO.2 2-3			Open			
OUT6	—	CNBH 1-3	Booster heater 1 output	OFF	ON	230 V AC 0.5 A Max. (Relay)	
OUT7	—	CNBH 5-7	Booster heater 2 output	OFF	ON	230 V AC 0.5 A Max. (Relay)	
OUT8	TBO.4 7-8	—	Cooling signal output	OFF	ON	230 V AC 0.5 A Max.	
OUT9	TBO.4 5-6	CNIH	Immersion heater output	OFF	ON	230 V AC 0.5 A Max. (Relay)	
OUT11	TBO.3 5-6	—	Error output	Normal	Error	230 V AC 0.5 A Max.	
OUT12	TBO.3 7-8	—	Defrost output	Normal	Defrost	230 V AC 0.5 A Max.	
OUT13	TBO.4 3-4	—	2-way valve 2a output *2	OFF	ON	230 V AC 0.1 A Max.	
OUT15	TBO.4 1-2	—	Comp ON signal	OFF	ON	230 V AC 0.5 A Max.	
OUT10	TBO.3 1-2	—	Boiler output	OFF	ON	non-voltage contact ·220 - 240 V AC (30 V DC) ·0.5 A or less ·10 mA 5 V DC or more	—
OUT16	TBO.3 3-4	—	Heating/Cooling thermo ON signal	OFF	ON		
OUTA1	TBI.4 7-8	—	Analog output	0 - 10 V		0 - 10 V DC 5 mA max.	—

Do not connect to the terminals that are indicated as “—” in the “Terminal block” field.

\*1 For 2-zone temperature control.

\*2 For 2-zone valve ON/OFF control.

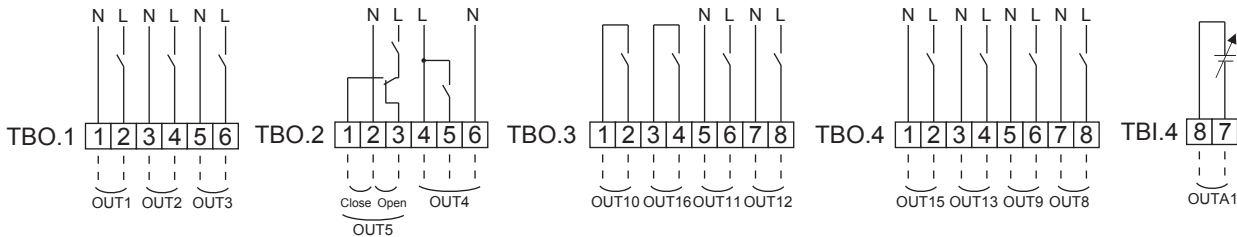

### How to use TBO.1 to 4

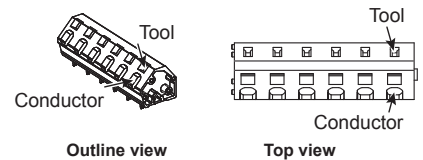

Connect them using either way as shown above.

<Figure 5.2.2>

### Wiring specification and local supply parts

Item	Name	Model and specifications
External output function	Outputs wire	Use sheathed vinyl coated cord or cable. Max. 30 m Wire type: CV, CVS or equivalent Wire size: Stranded wire 0.25 mm <sup>2</sup> to 1.5 mm <sup>2</sup> Solid wire: $\phi$ 0.57 mm to $\phi$ 1.2 mm

### Notes:

- When the cylinder unit is powered via outdoor unit, the maximum grand total current of (a)+(b) is 3.0 A.
- Do not connect multiple water circulation pumps directly to each output (OUT1, OUT2, and OUT3). In such a case, connect them via (a) relay(s).
- Do not connect water circulation pumps to both TBO.1 1-2 and CNP1 at the same time.
- Connect an appropriate surge absorber to OUT10 (TBO.3 1-2) depending on the load at site.
- Stranded wire should be processed with insulation-covered bar terminal (DIN46228-4 standard compatible type).
- Use the same thing as the Signal input wire for OUTA1 wiring.

## 5.3 Wiring for 2-zone temperature control

Connect the pipe work and locally supplied parts according to the relevant circuit diagram shown “Local system” in Section 3, of this manual.

<Mixing valve>

Connect the signal line to open Port A (hot water inlet port) to TBO. 2-3 (Open), the signal line to open Port B (cold water inlet port) to TBO. 2-1 (Close), and the neutral terminal wire to TBO. 2-2 (N).

<Thermistor>

- Do not install the thermistors on the mixing tank.
- Install the Zone2 flow temp. thermistor (THW8) near the mixing valve.
- The maximum length of the thermistor wiring is 30 m.
- The length of the optional thermistors are 5 m. If you need to splice and extend the wirings, following points must be carried out.
  - Connect the wirings by soldering.
  - Insulate each connecting point against dust and water.

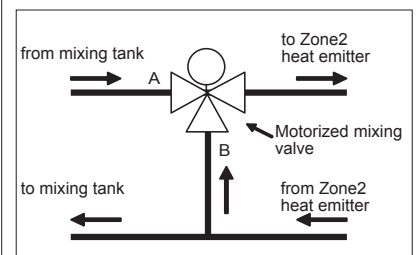
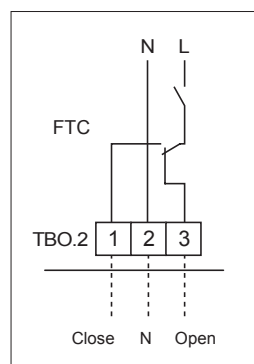

# 5 System Set Up

## 5.4 Indoor unit only operation (during installation work)

In the case when DHW or heating operation is required prior to connection of the outdoor unit; i.e. during installation work, an electric heater in indoor unit (\*1) can be used.

\*1 Model with electric heater only.

1. To start operation

- Check if the indoor unit power supply is OFF, and turn DIP switch 4-4 and 4-5 ON.
- Turn ON the indoor unit power supply.

2. To end operation\*2

- Turn OFF the indoor unit power supply.
- Turn DIP switch 4-4 and 4-5 OFF.

\*2 When the indoor unit only operation is ended, ensure to check over the settings after outdoor unit is connected.

**Note:**

**Prolonged running of this operation may affect the life of the electric heater.**

## 5.5 Smart grid ready

In DHW or heating operation, the commands in the table below can be used.

IN11	IN12	Meaning
OFF (open)	OFF (open)	Normal operation
ON (short)	OFF (open)	Switch-on recommendation
OFF (open)	ON (short)	Switch-off command
ON (short)	ON (short)	Switch-on command

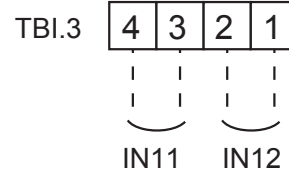

## en 5.6 Using SD memory card

The cylinder unit is equipped with an SD memory card interface in FTC.

Using an SD memory card can simplify main remote controller settings and can store operating logs. \*1

\*1 To edit main remote controller settings or to check operating data, an Ecodan service tool (for use with PC) is required.

### <Handling precautions>

- (1) Use an SD memory card that complies with the SD standards. Check that the SD memory card has a logo on it of those shown to the right.
- (2) SD memory cards to the SD standards include SD, SDHC, mini SD, micro SD, and micro SDHC memory cards. The capacities are available up to 32 GB. Choose that with a maximum allowable temperature of 55°C.
- (3) When the SD memory card is a mini SD, mini SDHC, micro SD, or micro SDHC memory card, use an SD memory card converter adapter.
- (4) Before writing to the SD memory card, release the write-protect switch.



- (5) Before inserting or ejecting an SD memory card, make sure to power off the system. If an SD memory card is inserted or ejected with the system powered on, the stored data could be corrupted or the SD memory card be damaged. \*An SD memory card is live for a short duration after the system is powered off. Before insertion or ejection wait until the LED lamps on the FTC control board are all off.
- (6) The read and write operations have been verified using the following SD memory cards, however, these operations are not always guaranteed as the specifications of these SD memory cards could change.

Manufacturer	Model	Tested in
Verbatim	#44015	Mar. 2012
SanDisk	SDSDB-002G-B35	Oct. 2011
Panasonic	RP-SDP04GE1K	Oct. 2011
Arvato	2GB PS8032 TSB 24nm MLC	Jun. 2012
Arvato	2GB PS8035 TSB A19nm MLC	Jul. 2014
SanDisk	SDSDUN-008G-G46	Oct. 2016
Verbatim	#43961	Oct. 2016
Verbatim	#44018	Oct. 2016
VANTASTEK	VSDHC08	Sep. 2017

Before using a new SD memory card (including the card that comes with the unit), always check that the SD memory card can be safely read and written to by the FTC controller.

<How to check read and write operations>

- a) Check for correct wiring of power supply to the system. For more details, refer to section 4.5.  
(Do not power on the system at this point.)
- b) Insert an SD memory card.
- c) Power on the system.
- d) The LED4 lamp lights if the read and write operations are successfully completed. If the LED4 lamp continues blinking or does not light, the SD memory card cannot be read or written to by the FTC controller.

- (7) Make sure to follow the instruction and the requirement of the SD memory card's manufacturer.
- (8) Format the SD memory card if determined unreadable in step (6). This could make it readable.  
Download an SD card formatter from the following site.  
SD Association homepage: <https://www.sdcard.org/home/>
- (9) FTC supports FAT file system but not NTFS file system.
- (10) Mitsubishi Electric is not liable for any damages, in whole or in part, including failure of writing to an SD memory card, and corruption and loss of the saved data, or the like. Back up saved data as necessary.
- (11) Do not touch any electronic parts on the FTC control board when inserting or ejecting an SD memory card, or else the control board could fail.

Logos
Capacities
2 GB to 32 GB *2
SD speed classes
All

- The SD Logo is a trademark of SD-3C, LLC.  
The mini SD logo is a trademark of SD-3C, LLC.  
The micro SD logo is a trademark of SD-3C, LLC.

\*2 A 2 GB SD memory card stores up to 30 days of operation logs.



# 5 System Set Up

## ■ [Initial setting wizard]

When the main remote controller is switched on for the first time, the screen automatically goes to Language setting screen , Date/Time setting screen and Main settings menu screen in order. Enter the desired number using the function keys and press CONFIRM.

**Note:**

<HEATER CAPACITY RESTRICTION>

This setting restricts the booster heater capacity. It is NOT possible to change the setting after starting up.

If you do not have any special requirements (such as building regulations) in your country, skip this setting (select "No").

- [Hot water (DHW/Legionella)]
- [Heating]/[Cooling]
- [Operation (ON/Prohibited/Timer)]
- [Pump speed]
- [Heat pump flow rate range]
- [Mixing valve control]
- [HEATER CAPACITY RESTRICTION]

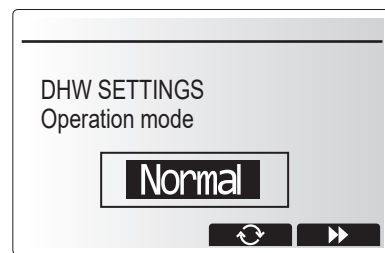
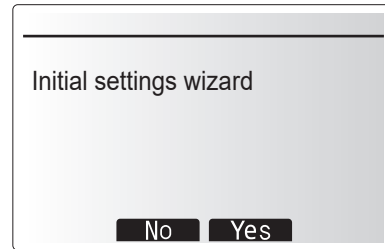

en

## ■ Main Settings Menu

The main settings menu can be accessed by pressing the MENU button. To reduce the risk of untrained end users altering the settings accidentally there are two access levels to the main settings; and the service section menu is password protected.

**User Level – Short press**

If the MENU button is pressed once for a short time the main settings will be displayed but without the edit function. This will enable the user to view current settings but **NOT** change the parameters.

**Installer Level – Long press**

If the MENU button is pressed down for 3 seconds the main settings will be displayed with all functionality available.

The color of ◀▶ buttons is inverted, as per figure on right. <Fig. 5.7.1>

The following items can be viewed and/or edited (dependent on access level).

- [Domestic Hot water (DHW)]
- [Heating/Cooling]
- [Schedule timer]
- [Holiday mode]
- [Initial settings]
- [Service (Password protected)]

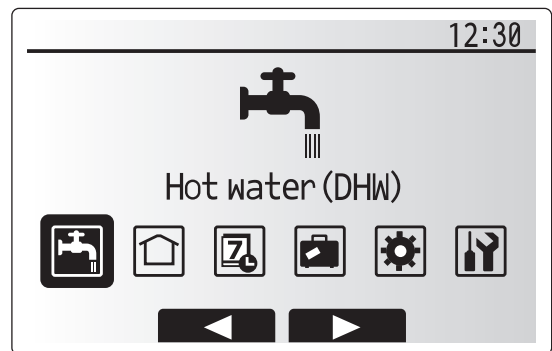

Main menu

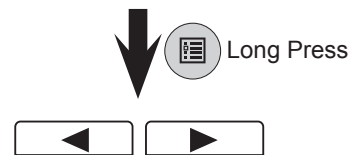

<Fig 5.7.1>

# 5 System Set Up

## <Main Controller Menu Tree>

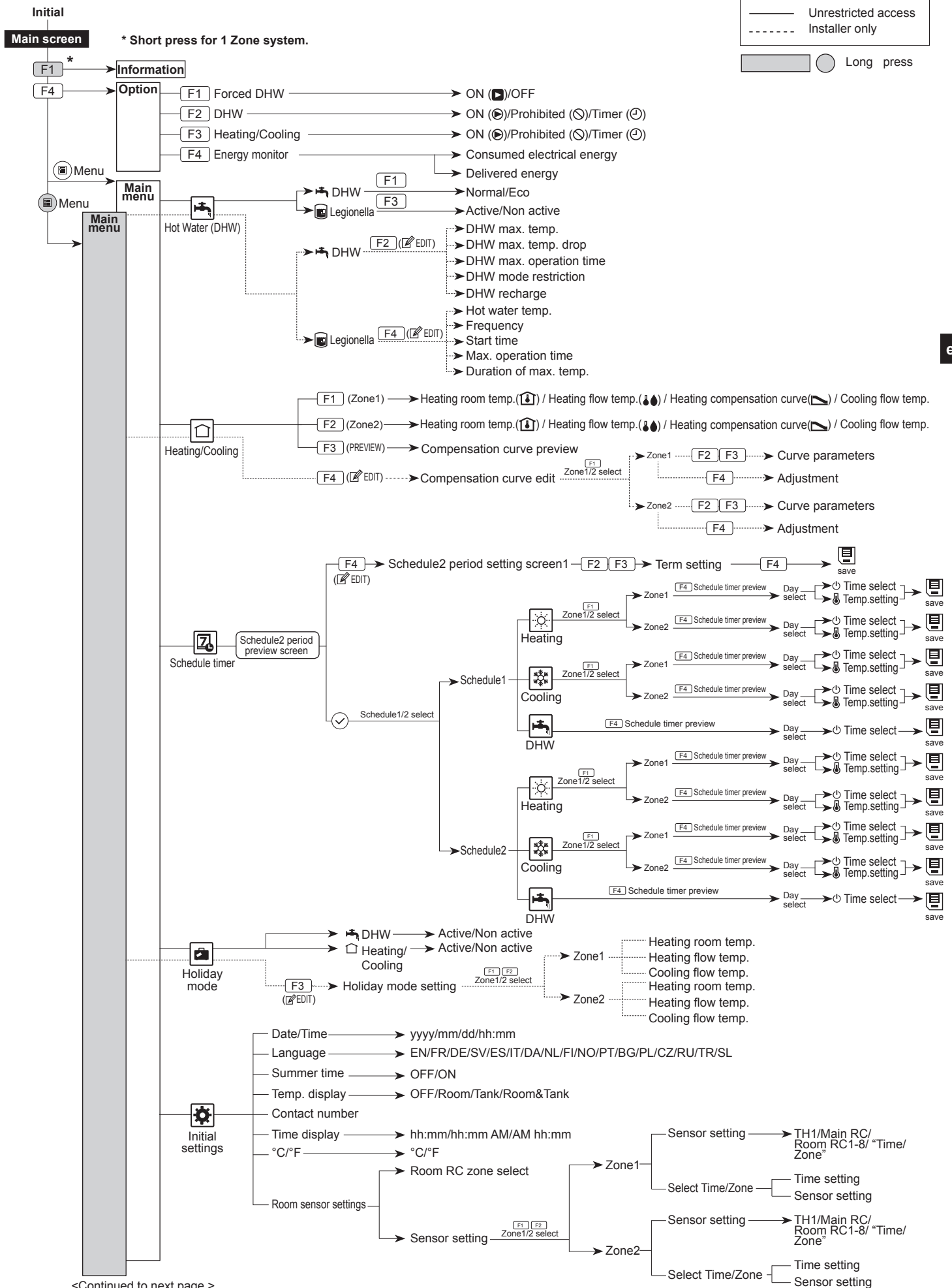

— Unrestricted access  
 - - - - - Installer only

⬜ ⬤ Long press

en

<Continued to next page.>

# 5 System Set Up

<Continued from the previous page.>

## <Main Controller Menu Tree>

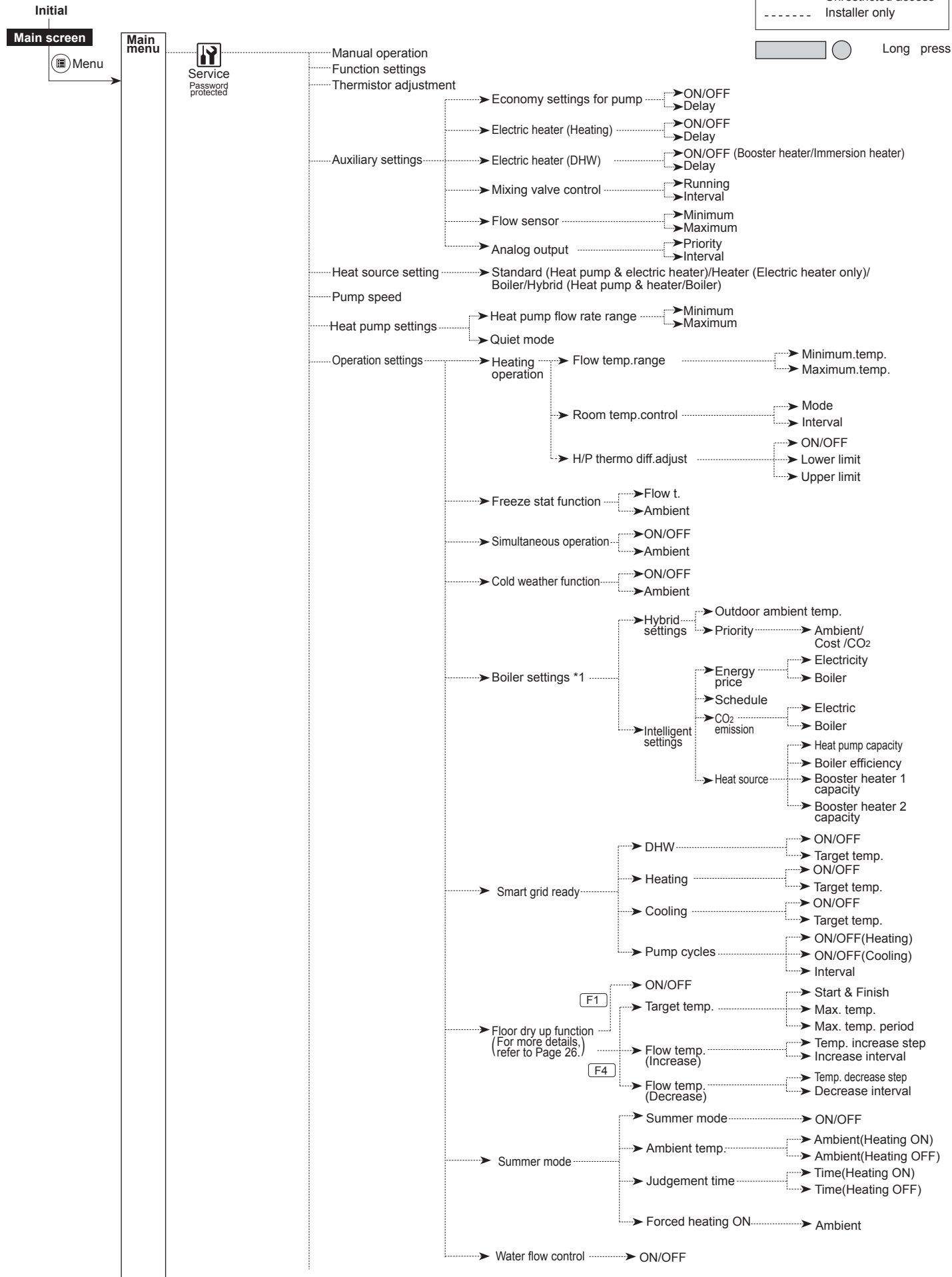
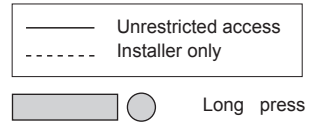

\*1 For more details, refer to the installation manual of PAC-TH012HT-(L)E.

# 5 System Set Up

<Continued from the previous page.>

## <Main Controller Menu Tree>

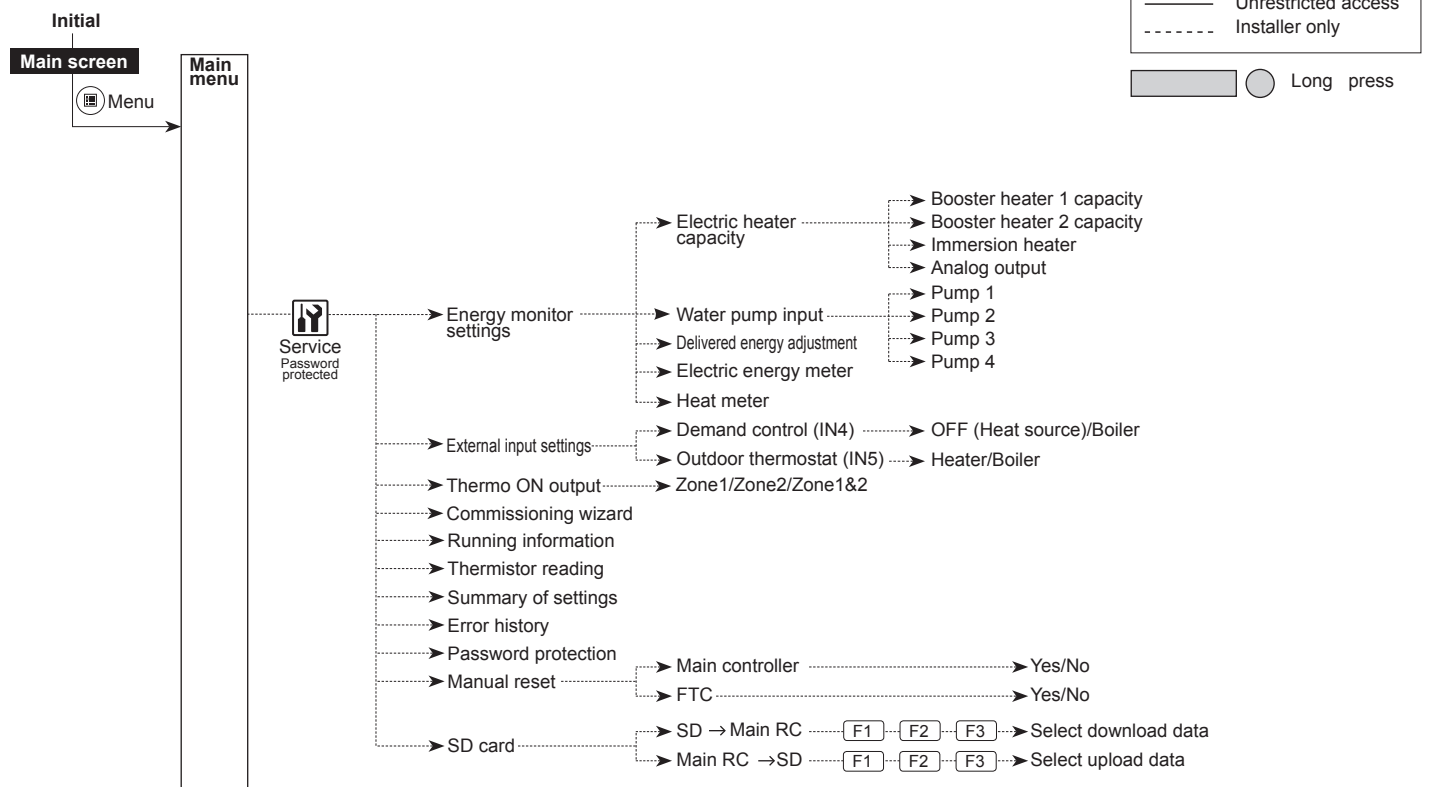

## Domestic Hot Water (DHW)/Legionella Prevention

The domestic hot water and legionella prevention menus control the operation of DHW tank heat ups.

### <DHW mode settings>

1. Highlight the hot water icon and press CONFIRM.
2. Use button F1 to switch between Normal and ECO heating modes.
3. To edit the mode, press down the MENU button for 3 seconds, then select "hot water".
4. Press F2 key to display the Hot Water (DHW) SETTING menu.
5. Use F2 and F3 keys to scroll through the menu selecting each component in turn by pressing CONFIRM. See the table below for description of each setting.
6. Enter the desired number using the function keys and press CONFIRM.



Menu subtitle	Function	Range	Unit	Default value
DHW max. temp.	Desired temperature of stored hot water	40 - 60	°C	50
DHW max. temp. drop	Difference in temperature between DHW max. temp. and the temperature at which DHW mode restarts	5 - 30 *	°C	10
DHW max. operation time	Max. time allowed for stored water heating DHW mode	30 - 120	min	60
DHW mode restriction	The time period after DHW mode when space heating has priority over DHW mode temporarily preventing further stored water heating (Only when DHW max. operation time has passed.)	30 - 120	min	30

\* When the DHW max. temp is set over 55°C, the temperature at which DHW mode restarts must be less than 50°C to protect the device.

### <Eco mode>

DHW mode can run in either 'Normal' or 'Eco' mode. Normal mode will heat the water in the DHW tank more quickly using the full power of the heat pump. Eco mode takes a little longer to heat the water in the DHW tank but the energy used is reduced. This is because heat pump operation is restricted using signals from the FTC based on measured DHW tank temperature.

**Note: The actual energy saved in Eco mode will vary according to outdoor ambient temperature.**

### <[DHW recharge]>

Select the amount of DHW. If you need much hot water, select LARGE, but increase operating costs.

Return to the DHW/legionella prevention menu.

# 5 System Set Up

## Legionella Prevention Mode settings (LP mode)

1. Use button F3 to choose legionella mode active YES/NO.
2. To edit the legionella function, press down the MENU button for 3 seconds and select "hot water", then press F4 key.
3. Use F1 and F2 keys to scroll through the menu selecting each subtitle in turn by pressing CONFIRM. See the table below for description of each setting.
4. Enter the desired number using the function keys and press CONFIRM.

During Legionella Prevention Mode the temperature of the stored water is increased above 60°C to inhibit legionella bacteria growth. It is strongly recommended that this is done at regular intervals. Please check local regulations for the recommended frequency of heat ups.

Please note that LP mode uses the assistance of electric heaters to supplement the energy input of the heat pump. Heating water for long periods of time is not efficient and will increase running costs. The installer should give careful consideration to the necessity of legionella prevention treatment whilst not wasting energy by heating the stored water for excessive time periods. The end user should understand the importance of this feature.  
**ALWAYS COMPLY WITH LOCAL AND NATIONAL GUIDANCE FOR YOUR COUNTRY REGARDING LEGIONELLA PREVENTION.**

**Note: When failures occur on the hydrobox, the LP mode may not function normally.**

Menu subtitle	Function	Range	Unit	Default value
Hot water temp.	Desired temp. of stored hot water	60 - 70	°C	65
Frequency	Time between LP mode DHW tank heat ups	1 - 30	day	15
Start time	Time when LP mode will begin	0:00 - 23:00	-	03:00
Max. operation time	Maximum time allowed for LP mode DHW tank heat	1 - 5	hour	3
Duration of max. temp.	The time period after LP mode desired water temp. has been reached	1 - 120	min	30

## [Initial Settings]

From the Initial settings menu the installer can set the following.

- [Date/Time] \*Be sure to set it to the local standard time.
- [Language]
- [Summer time]
- [Temp. display]
- [Contact number]
- [Time display]
- [°C/°F]
- [Room sensor settings]

Follow the procedure described in General Operation for the set up operation.

### <[Room sensor settings]>

For room sensor settings it is important to choose the correct room sensor depending on the heating mode the system will operate in.

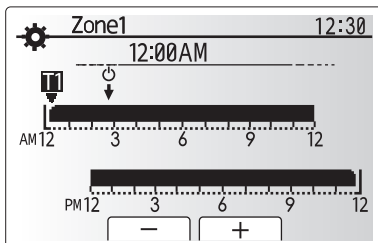

Time/Zone schedule setting screen

Menu subtitle	Description																				
Room RC zone select	When 2-zone temperature control is active and wireless remote controllers are available, from Room RC zone select screen, select zone no. to assign to each main remote controller.																				
Sensor setting	From sensor setting screen, select a room sensor to be used for monitoring the room temperature from Zone1 and Zone2 separately. <table border="1" style="margin-top: 10px;"> <thead> <tr> <th rowspan="2">Control option (Website manual)</th> <th colspan="2">Corresponding initial settings room sensor</th> </tr> <tr> <th>Zone1</th> <th>Zone2</th> </tr> </thead> <tbody> <tr> <td>A</td> <td>Room RC 1-8 (one each for Zone1 and Zone2)</td> <td>*1</td> </tr> <tr> <td>B</td> <td>TH1</td> <td>*1</td> </tr> <tr> <td>C</td> <td>Main remote controller</td> <td>*1</td> </tr> <tr> <td>D</td> <td>*1</td> <td>*1</td> </tr> <tr> <td>When different room sensors are used according to the time schedule</td> <td>Time/ Zone*2</td> <td>*1</td> </tr> </tbody> </table>	Control option (Website manual)	Corresponding initial settings room sensor		Zone1	Zone2	A	Room RC 1-8 (one each for Zone1 and Zone2)	*1	B	TH1	*1	C	Main remote controller	*1	D	*1	*1	When different room sensors are used according to the time schedule	Time/ Zone*2	*1
Control option (Website manual)	Corresponding initial settings room sensor																				
	Zone1	Zone2																			
A	Room RC 1-8 (one each for Zone1 and Zone2)	*1																			
B	TH1	*1																			
C	Main remote controller	*1																			
D	*1	*1																			
When different room sensors are used according to the time schedule	Time/ Zone*2	*1																			

- \*1. Not specified (if a locally-supplied room thermostat is used)  
Room RC 1-8 (one each for Zone1 and Zone2) (if a wireless remote controller is used as a room thermostat)
- \*2. From sensor setting screen, select Time/Zone to make it possible to use different room sensors according to the time schedule set in the Select Time/ Zone menu. The room sensors can be switched up to 4 times within 24 hours.

## [Service] Menu

The service menu provides functions for use by installer or service engineer. It is NOT intended the home owner alters settings within this menu. It is for this reason password protection is required to prevent unauthorised access to the service settings.

The factory default password is "0000".

Follow the procedure described in General Operation for the set up operation.

Many functions can not be set whilst the indoor unit is running. The installer should turn off the unit before trying to set these functions. If the installer attempts to change the settings whilst the unit is running the main remote controller will display a reminder message prompting the installer to stop operation before continuing. By selecting "Yes" the unit will cease operation.

### <[Manual operation]>

During the filling of the system the primary circuit circulation pump and 3-way valve can be manually overridden using manual operation mode.

When manual operation is selected a small timer icon appears in the screen. When selected, this function will only remain in manual operation for a maximum of 2 hours. This is to prevent accidental permanent override of the FTC.

#### ► Example

Pressing F3 button will switch manual operation mode ON for the main 3-way valve. When filling of the DHW tank is complete the installer should access this menu again and press F3 to deactivate manual operation of the part. Alternatively after 2 hours manual operation mode will no longer be active and FTC can resume control of the cylinder unit.

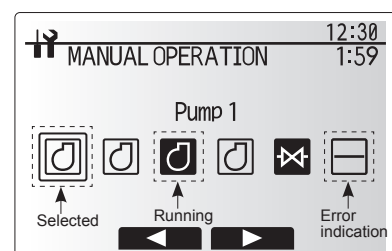

Manual operation menu screen

## 5 System Set Up

Manual operation and heat source setting can not be selected if the system is running. A screen will be displayed asking the installer to stop the system before these modes can be activated.  
The system automatically stops 2 hours after last operation.

### <[Floor dry up function]>

The Floor dry up function automatically changes the target hot water temperature in stages to gradually dry concrete when this particular type of underfloor heating system is installed.

Upon completion of the operation the system stops all the operations except the Freeze stat. operation.

For Floor dry up function, the target flow temp. of Zone1 is the same as that of Zone2.

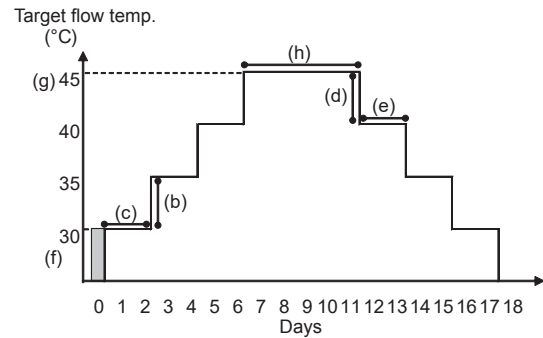

- This function is not available when a PUAZ-FRP outdoor unit is connected.
- Disconnect wiring to external inputs of room thermostat, demand control, and outdoor thermostat, or the target flow temperature may not be maintained.

Functions	Symbol	Description	Option/Range	Unit	Default	
Floor dry up function	a	Set the function to ON and power on the system using the main remote controller, and the dry up heating operation will start.	On/Off	—	Off	
Flow temp. (increase)	Flow temp. increase step	b	Sets the increase step of the target flow temperature.	+1 to +10	°C	+5
	Increase interval	c	Sets the period for which the same target flow temperature is maintained.	1 to 7	day	2
Flow temp. (decrease)	Flow temp. decrease step	d	Sets the decrease step of the target flow temperature.	-1 to -10	°C	-5
	Decrease interval	e	Sets the period for which the same target flow temperature is maintained.	1 to 7	day	2
Target temperature	Start & Finish	f	Sets the target flow temperature at the start and the finish of the operation.	20 to 60	°C	30
	Max. target temp.	g	Sets the maximum target flow temperature.	20 to 60	°C	45
	Max. temp. period	h	Sets the period for which the maximum target flow temperature is maintained.	1 to 20	day	5

### <[Password protection]>

Password protection is available to prevent unauthorised access to the service menu by untrained persons.

#### Resetting the password

If you forget the password you entered, or have to service a unit somebody else installed, you can reset the password to the factory default of **0000**.

1. From the main settings menu scroll down the functions until Service Menu is highlighted.
2. Press CONFIRM.
3. You will be prompted to enter a password.
4. Hold down buttons F3 and F4 together for 3 seconds
5. You will be asked if you wish to continue and reset the password to default setting.
6. To reset press button F3.
7. The password is now reset to **0000**.

### <[Manual reset]>

Should you wish to restore the factory settings at any time you should use the manual reset function. Please note this will reset ALL functions to the factory default settings.



Password input screen



Password verify screen

## 6 Commissioning

### ■ Pre-commissioning exercises- potable/DHW circuit

Initial fill procedure:

Ensure all pipe joints and fittings are tight and secure.

Open the most distant DHW tap/outlet.

Slowly/gradually open the mains water supply to begin filling unit and DHW pipework.

Allow most distant tap to run free and release/purge residual air from installation.

Close tap/outlet to retain fully charged system.

**Note: When an immersion heater is fitted, do NOT energise the heater until the DHW tank is full of water. Also do NOT energise any immersion heater if any sterilisation chemicals remain in the DHW tank as this will cause premature failure of the heater.**

Initial flush procedure:

Energise system to heat-up cylinder unit contents to a temperature of approx. 30 - 40°C.

Flush/drain the water contents to remove any residue/impurities resulting from the installation works. Use the cylinder unit drain cock to safely discharge the warmed water to drain via a suitable hose.

On completion, close drain cock, re-fill system and resume system commissioning.

# 7 Service and Maintenance

## ■ Error Codes

Code	Error	Action
L3	Circulation water temperature overheat protection	Flow rate may be reduced. Check for; <ul style="list-style-type: none"> <li>• Water leakage</li> <li>• Strainer blockage</li> <li>• Water circulation pump function (Error code may display during filling of primary circuit, complete filling and reset error code.)</li> </ul>
L4	DHW tank water temperature overheat protection	Check the immersion heater and it's contactor.
L5	Indoor unit temperature thermistor (THW1, THW2, THW5A, THW5B, THW6, THW7, THW8, THW9) failure	Check resistance across the thermistor.
L6	Circulation water freeze protection	See Action for L3.
L8	Heating operation error	Check and re-attach any thermistors that may have become dislodged.
L9	Low primary circuit flow rate detected by flow sensor or flow switch (flow switches 1, 2, 3)	See Action for L3. If the flow sensor or flow switch itself does not work, replace it. <b>Caution: The pump valves may be hot, please take care.</b>
LA	Pressure sensor failure	Check pressure sensor cable for damage or loose connections.
LB	High pressure protection	<ul style="list-style-type: none"> <li>• Flow rate of the heating circuit may be reduced. Check water circuit.</li> <li>• Plate heat exchanger may be clogged. Check the plate heat exchanger.</li> <li>• Outdoor unit failure. Refer to outdoor unit service manual.</li> </ul>
LC	Boiler circulation water temperature overheat protection	<p>Check if the setting temperature of the Boiler for heating exceeds the restriction. (See the manual of the thermistors "PAC-TH012HT-E")</p> <p>Flow rate of the heating circuit from the boiler may be reduced. Check for</p> <ul style="list-style-type: none"> <li>• water leakage,</li> <li>• strainer blockage</li> <li>• water circulation pump function.</li> </ul>
LD	Boiler temperature thermistor (THWB1) failure	Check resistance across the thermistor.
LE	Boiler operation error	See Action for L8. Check the status of the boiler.
LF	Flow sensor failure	Check flow sensor cable for damage or loose connections.
LH	Boiler circulation water freeze protection	Flow rate of the heating circuit from the boiler may be reduced. Check for <ul style="list-style-type: none"> <li>• water leakage</li> <li>• strainer blockage</li> <li>• water circulation pump function.</li> </ul>
LJ	DHW operation error (type of external plate HEX)	<ul style="list-style-type: none"> <li>• Check for disconnection of DHW tank water lower temp. thermistor (THW5B).</li> <li>• Flow rate of the sanitary circuit may be reduced.</li> <li>• Check for water circulation pump function. (primary / sanitary)</li> </ul>
LL	Setting errors of DIP switches on FTC control board	For boiler operation, check that DIP SW1-1 is set to ON (With Boiler) and DIP SW2-6 is set to ON (With Mixing Tank). For 2-zone temperature control, check DIP SW2-7 is set to ON (2-zone) and DIP SW2-6 is set to ON (With Mixing Tank).
LP	Out of water flow rate range for outdoor heat pump unit	Check the installation Table 4.3.1 Check remote controller settings (Service menu / heat pump flow rate range) See Action for L3.
P1	Thermistor (Room temp.) (TH1) failure	Check resistance across the thermistor.
P2	Thermistor (Ref. liquid temp.) (TH2) failure	Check resistance across the thermistor.
P6	Anti-freeze protection of plate heat exchanger	See Action for L3. Check for correct amount of refrigerant.
J0	Communication failure between FTC and wireless receiver	Check connection cable for damage or loose connections.
J1 - J8	Communication failure between wireless receiver and wireless remote controller	Check wireless remote controller's battery is not flat. Check the pairing between wireless receiver to wireless remote controller. Test the wireless communication. (See the manual of wireless system)
E0 - E5	Communication failure between main remote controller and FTC	Check connection cable for damage or loose connections.
E6 - EF	Communication failure between FTC and outdoor unit	Check that the outdoor unit has not been turned off. Check connection cable for damage or loose connections. Refer to outdoor unit service manual.
E9	Outdoor unit receives no signal from indoor unit.	Check both units are switched on. Check connection cable for damage or loose connections. Refer to outdoor unit service manual.
EE	Combination error between FTC and outdoor unit	Check combination of FTC and outdoor unit.
U*, F*	Outdoor unit failure	Refer to outdoor unit service manual.
A*	M-NET communication error	Refer to outdoor unit service manual.

**Note: To cancel error codes please switch system off (Press button F4(RESET) on main remote controller).**

# 7 Service and Maintenance

## ■ Annual Maintenance

It is essential that the cylinder unit is serviced at least once a year by a qualified individual. Any required parts should be purchased from Mitsubishi Electric. NEVER bypass safety devices or operate the unit without them being fully operational. For more details, refer to service handbook.

Notes		
<ul style="list-style-type: none"> <li>• Within the first couple of months of installation, remove and clean the cylinder unit's strainer plus any additional filter items that are fitted external to the cylinder unit. This is especially important when installing on an old/existing pipe work system.</li> <li>• The PRV valve and T&amp;P valve (No. 8, 20 and 21 on Figure 3.1) should be checked annually by turning the knob manually so that the medium is discharged, thus cleaning the seal seat.</li> </ul>		

In addition to annual servicing it is necessary to replace or inspect some parts after a certain period of system operation. Please see tables below for detailed instructions. Replacement and inspection of parts should always be done by a competent person with relevant training and qualifications.

### Parts which require regular replacement

Parts	Replace every	Possible failures
Pressure relief valve (PRV) Manometer Inlet control group (ICG)*	6 years	Water leakage

\* OPTIONAL PARTS for UK

### Parts which require regular inspection

Parts	Check every	Possible failures
Pressure relief valve (3bar) Temperature and pressure relief valve	1 year (turning the knob manually)	PRV would be fixed and expansion vessel would burst
Immersion heater	2 years	Earth leakage causing circuit breaker to activate (Heater is always OFF)
Water circulation pump (Primary circuit)	20,000 hrs (3 years)	Water circulation pump failure

en

### Parts which must NOT be re-used when servicing

- \* O-ring
- \* Gasket

#### Note:

- Always replace the gasket for pump with a new one at each regular maintenance (every 20,000 hours of use or every 3 years).

### <Draining the cylinder unit and its sanitary heating circuit (local)>

#### WARNING: DRAINED WATER MAY BE VERY HOT

1. Before attempting to drain the cylinder unit isolate from the electrical supply to prevent the immersion and booster heaters burning out.
2. Isolate cold water feed to DHW tank.
3. Open a hot water tap to allow draining without creating a vacuum.
4. Attach a hose to the DHW tank drain cocks (No. 22 and 23 on Figure 7.1). The hose should be able to withstand heat as the draining water could be very hot. The hose should drain to a place lower than the DHW tank bottom to encourage siphoning. Begin draining by opening drain cock.
5. When the DHW tank is drained close drain cock and hot tap.
6. For primary circuit, attach hose to water circuit drain cocks (No. 6 on Figure 3.1). The hose should be able to withstand heat as the draining water could be very hot. The hose should drain to a place lower than the drain cock to encourage siphoning. Open the pump valves and the strainer valves.
7. Water remains in the strainer still after the cylinder unit was drained.  
Drain the strainer by removing the strainer cover.

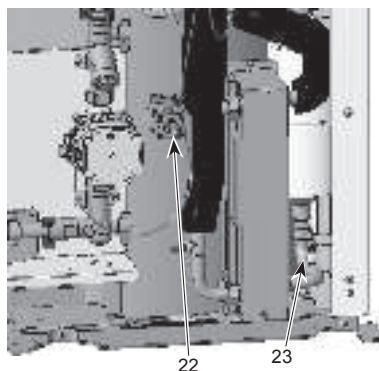

<Figure 7.1>

# 7 Service and Maintenance

## Engineers Forms

Should settings be changed from default, please enter and record new setting in 'Field Setting' column. This will ease resetting in the future should the system use change or the circuit board need to be replaced.

### Commissioning/Field settings record sheet

Main remote controller screen		Parameters	Default setting	Field setting	Notes	
<b>Main</b>		Zone1 heating room temp.	10°C to 30°C	20°C		
		Zone2 heating room temp. *1	10°C to 30°C	20°C		
		Zone1 heating flow temp.	20°C to 60°C	45°C		
		Zone2 heating flow temp. *2	20°C to 60°C	35°C		
		Zone1 cooling flow temp. *3	5°C to 25°C	15°C		
		Zone2 cooling flow temp. *3	5°C to 25°C	20°C		
		Zone1 heating compensation curve	-9°C to +9°C	0°C		
		Zone2 heating compensation curve *2	-9°C to +9°C	0°C		
<b>Option</b>		Holiday mode	Active/Non active/Set time	—		
		Forced DHW operation	On/Off	—		
		DHW	On/Off/Timer	On		
		Heating/Cooling *3	On/Off/Timer	On		
<b>Setting</b>	DHW	Energy monitor	Consumed electrical energy/Delivered energy	—		
		Operation mode	Normal/Eco *4	Normal		
		DHW max. temp.	40°C to 60°C *5	50°C		
		DHW temp. drop	5°C to 30°C	10°C		
		DHW max. operation time	30 to 120 min	60 min		
		DHW mode restriction	30 to 120 min	30 min		
		DHW recharge	Large/Standard	Standard		
	Legionella prevention	Active	Yes/No	Yes		
		Hot water temp.	60°C to 70°C *5	65°C		
		Frequency	1 to 30 days	15 days		
		Start time	00:00 to 23:00	03:00		
		Max. operation time	1 to 5 hours	3 hours		
		Duration of maximum temp.	1 to 120 min	30 min		
	Heating/Cooling *3	Zone1 operation mode	Heating room temp./ Heating flow temp./ Heating compensation curve/ Cooling flow temp.	Room temp.		
		Zone2 operation mode *2	Heating room temp./ Heating flow temp./ Heating compensation curve/ Cooling flow temp.	Compensation curve		
	Compensation curve	Hi flow temp. set point	Zone1 outdoor ambient temp.	-30°C to +33°C *6	-15°C	
			Zone1 flow temp.	20°C to 60°C	50°C	
			Zone2 outdoor ambient temp. *2	-30°C to +33°C *6	-15°C	
			Zone2 flow temp. *2	20°C to 60°C	40°C	
		Lo flow temp. set point	Zone1 outdoor ambient temp.	-28°C to +35°C *7	35°C	
			Zone1 flow temp.	20°C to 60°C	25°C	
			Zone2 outdoor ambient temp. *2	-28°C to +35°C *7	35°C	
			Zone2 flow temp. *2	20°C to 60°C	25°C	
		Adjust	Zone1 outdoor ambient temp.	-29°C to +34°C *8	—	
			Zone1 flow temp.	20°C to 60°C	—	
			Zone2 outdoor ambient temp. *2	-29°C to +34°C *8	—	
			Zone2 flow temp. *2	20°C to 60°C	—	
	Holiday	DHW	Active/Non active	Non active		
Heating/Cooling *3		Active/Non active	Active			
Zone1 heating room temp.		10°C to 30°C	15°C			
Zone2 heating room temp. *1		10°C to 30°C	15°C			
Zone1 heating flow temp.		20°C to 60°C	35°C			
Zone2 heating flow temp. *2		20°C to 60°C	25°C			
Zone1 cooling flow temp. *3		5°C to 25°C	25°C			
Zone2 cooling flow temp. *3		5°C to 25°C	25°C			
Initial settings	Language	EN/FR/DE/SV/ES/IT/DA/NL/FI/NO/PT/BG/PL/CZ/RU/TR/SL	EN			
	°C/°F	°C/°F	°C			
	Summer time	On/Off	Off			
	Temp. display	Room/DHW tank/Room&DHW tank /Off	Off			
	Time display	hh:mm/hh:mm AM/AM hh:mm	hh:mm			
	Room sensor settings for Zone1	TH1/Main RC/Room RC1-8/"Time/Zone"	TH1			
	Room sensor settings for Zone2 *2	TH1/Main RC/Room RC1-8/"Time/Zone"	TH1			
	Room RC zone select *2	Zone1/Zone2	Zone1			
	Service menu	Thermistor adjustment	THW1	-10°C to +10°C	0°C	
			THW2	-10°C to +10°C	0°C	
THW5A			-10°C to +10°C	0°C		
THW5B			-10°C to +10°C	0°C		
THW6			-10°C to +10°C	0°C		
THW7			-10°C to +10°C	0°C		
THW8			-10°C to +10°C	0°C		
THW9			-10°C to +10°C	0°C		
THW10			-10°C to +10°C	0°C		
THWB1			-10°C to +10°C	0°C		
Auxiliary settings			Economy settings for pump.	On/Off *9	On	
		Delay (3 to 60 min)		10 min		
		Electric heater (Heating)	Space heating: On (used)/Off (not used)	On		
		Electric heater (DHW)	Electric heater delay timer (5 to 180 min)	30 min		
		Booster heater	DHW: On (used)/Off (not used)	On		
		Immersion heater	DHW: On (used)/Off (not used)	On		
		Electric heater delay timer (15 to 30 min)		15 min		
		Mixing valve control	Running (10 to 240 sec)	120 sec		
		Interval (1 to 30 min)		2 min		
Flow sensor *10		Minimum (0 to 100 L/min)		5 L/min		
	Maximum (0 to 100 L/min)		100 L/min			
	Interval (1 to 30 min)		5 min			
Analog output	Priority (Normal/High)		Normal			

(Continued to next page.)

# 7 Service and Maintenance

## ■ Engineers Forms

Commissioning/Field settings record sheet (continued from the previous page)

Main remote controller screen				Parameters	Default setting	Field setting	Notes		
Setting	Service menu	Pump speed	DHW	Pump speed (1 to 5)	5				
			Heating/Cooling	Pump speed (1 to 5)	5				
		Heat source setting		Standard/Heater/Boiler/Hybrid *11	Standard				
		Heat pump setting	Heat pump flow rate range	Minimum (0 to 100 L/min)	5 L/min				
				Maximum (0 to 100 L/min)	100 L/min				
			Quiet mode	Day (Mon to Sun)	—				
				Time	0:00 to 23:45				
				Quiet level (Normal/ Level1/ Level2)	Normal				
		Operation settings	Heating operation	Flow temp.range *13	Minimum.temp. (20 to 45°C)	30°C			
					Maximum.temp. (35 to 60°C)	50°C			
				Room temp.control *14	Mode (Normal/Fast)	Normal			
					Interval (10 to 60 min)	10 min			
				Heat pump thermo diff.adjust	On/Off *9	On			
					Lower limit (-9 to -1°C)	-5°C			
					Upper limit (+3 to +5°C)	5°C			
			Freeze stat function *15		Outdoor ambient temp. (3 to 20°C) / **	5°C			
			Simultaneous operation (DHW/Heating)		On/Off *9	Off			
					Outdoor ambient temp. (-30 to +10°C) *6	-15°C			
			Cold weather function		On/Off *9	Off			
					Outdoor ambient temp. (-30 to -10°C) *6	-15°C			
			Boiler operation	Hybrid settings		Outdoor ambient temp. (-30 to +10°C) *6	-15°C		
						Priority mode (Ambient/Cost/CO <sub>2</sub> ) *16	Ambient		
					Outdoor ambient temp. rise (+1 to +5°C)	+3°C			
		Intelligent settings		Energy price *17	Electricity (0.001 to 999 */kWh)	0.5 */kWh			
					Boiler (0.001 to 999 */kWh)	0.5 */kWh			
				CO <sub>2</sub> emission	Electricity (0.001 to 999 kg -CO <sub>2</sub> /kWh)	0.5 kg -CO <sub>2</sub> /kWh			
					Boiler (0.001 to 999 kg -CO <sub>2</sub> /kWh)	0.5 kg -CO <sub>2</sub> /kWh			
		Heat source		Heat pump capacity (1 to 40 kW)	11.2 kW				
				Boiler efficiency (25 to 150%)	80%				
				Booster heater 1 capacity (0 to 30 kW)	2 kW				
			Booster heater 2 capacity (0 to 30 kW)	4 kW					
		Smart grid ready	DHW	On/Off	Off				
				Target temp (+1 to +20°C) / -- (Non active)	--				
			Heating	On/Off	Off				
				Target temp.	Switch-on recommendation (20 to 60°C) Switch-on command (20 to 60°C)	50°C 55°C			
			Cooling	On/Off	Off				
				Target temp.	Switch-on recommendation (5 to 25°C) Switch-on command (5 to 25°C)	15°C 10°C			
			Pump cycles	Heating (On/Off)	On				
				Cooling (On/Off)	On				
				Interval (10 to 120 min)	10 min				
		Floor dry up function	On/Off *9	Target temp.	Start&Finish (20 to 60°C)	30°C			
					Max. temp. (20 to 60°C)	45°C			
					Max. temp. period (1 to 20 days)	5 days			
				Flow temp. (Increase)	Temp. increase step (+1 to +10°C)	+5°C			
			Increase interval (1 to 7 days)		2 days				
			Flow temp. (Decrease)	Temp. decrease step (-1 to -10°C)	-5°C				
				Decrease interval (1 to 7 days)	2 days				
Summer mode	On/Off		Outdoor ambient temp.	Heating ON (4 to 19°C)	10°C				
		Heating OFF (5 to 20°C)		15°C					
	Judgement time	Heating ON (1 to 48 hours)	6 hours						
		Heating OFF (1 to 48 hours)	6 hours						
			Forced heating ON (-30 to 10°C)	5°C					
			On/Off	Off					
Water flow control			Off						

(Continued to next page.)

# 7 Service and Maintenance

## ■ Engineers Forms

Commissioning/Field settings record sheet (continued from the previous page)

Main remote controller screen				Parameters	Default setting	Field setting	Notes	
en	Service menu	Energy monitor settings	Electric heater capacity	Booster heater 1 capacity	0 to 30 kW	2 kW		
				Booster heater 2 capacity	0 to 30 kW	4 kW		
				Immersion heater capacity	0 to 30 kW	0 kW		
				Analog output	0 to 30 kW	0 kW		
			Delivered energy adjustment	-50 to +50%	0%			
			Water pump input	Pump 1	0 to 200 W or *(factory fitted pump)	*		
				Pump 2	0 to 200 W	0 W		
				Pump 3	0 to 200 W	0 W		
				Pump 4	0 to 200 W	72 W		
			Electric energy meter *12	0.1/1/10/100/1000 pulse/kWh	1000 pulse/kWh			
		Heat meter *12	0.1/1/10/100/1000 pulse/kWh	1000 pulse/kWh				
		External input settings	Demand control (IN4)	Heat source OFF/Boiler operation	Boiler operation			
			Outdoor thermostat (IN5)	Heater operation/Boiler operation	Boiler operation			
		Thermo ON output	Zone1/Zone2/Zone1&2	Zone1&2				

\*1 The settings related to Zone2 can be switched only when 2-zone temperature control or 2-Zone valve ON/OFF control is active.

\*2 The settings related to Zone2 can be switched only when 2-zone temperature control is enabled (when DIP SW2-6 and SW 2-7 are ON).

\*3 Cooling mode settings are available for ER model only.

\*4 When the cylinder unit is connected with a PUMY-P outdoor unit, the mode is fixed to "Normal".

\*5 For the model without both booster and immersion heater, it may not reach the set temperature depending on the outside ambient temperature.

\*6 The lower limit is -15°C depending on the connected outdoor unit.

\*7 The lower limit is -13°C depending on the connected outdoor unit.

\*8 The lower limit is -14°C depending on the connected outdoor unit.

\*9 On: the function is active; Off: the function is inactive.

\*10 Do not change the setting since it is set according to the specification of flow sensor attached to the cylinder unit.

\*11 When DIP SW1-1 is set to OFF "WITHOUT Boiler" or SW2-6 is set to OFF "WITHOUT Mixing tank", neither Boiler nor Hybrid can be selected.

\*12 The default setting is 1 pulse/kWh depending on the connected indoor unit.

\*13 Valid only when operating in Heating room temperature.

\*14 When DIP SW5-2 is set to OFF, the function is active.

\*15 If asterisk (\*) is chosen freeze stat function is deactivated. (i.e. primary water freeze risk)

\*16 When the cylinder unit is connected with a PUMY-P outdoor unit, the mode is fixed to "Ambient".

\*17 "\*" of "\*/kWh" represents currency unit (e.g. € or £ or the like)





EC DECLARATION OF CONFORMITY  
EG-KONFORMITÄTSEKHLÄRUNG  
DECLARATION DE CONFORMITÉ CE  
EG-CONFORMITEITSEVERKLARING  
DECLARACIÓN DE CONFORMIDAD CE  
DICHIARAZIONE DI CONFORMITÀ CE

ΔΗΛΩΣΗ ΠΙΣΤΟΤΗΤΑΣ ΕΚ  
DECLARAÇÃO DE CONFORMIDADE CE  
EU-OVERENSSTEMMELSESEKHLÆRING  
EG-DEKLARATION OM ÖVERENSSTÄMMELSE  
ЕС ДЕКЛАРАЦИЯ ЗА СЪОТВЕТСТВИЕ  
DEKLARACJA ZGODNOŚCI WE

CE-ERKLÆRING OM SAMSVAR  
EY-VAATIMUSTENMUKAISUUSVAKUUTUS  
ES PROHLÁŠENÍ O SHODĚ  
VYHLÁŠENIE O ZHODE ES  
EK MEGFELELŐSÉGI NYILATKOZAT  
IZJAVA O SKLADNOSTI ES

DECLARAȚIE DE CONFORMITATE CE  
EÜ VASTAVUSDEKLARATSIOON  
EK ATBILSTĪBAS DEKLARĀCIJA  
EB ATITIKTIES DEKLARACIJA  
EC IZJAVA O SUKLADNOSTI  
EZ IZJAVA O USAGLAŠENOSTI

**NETTLEHILL ROAD, HOUSTOUN INDUSTRIAL ESTATE, LIVINGSTON, EH54 5EQ, SCOTLAND, UNITED KINGDOM**

hereby declares under its sole responsibility that the heating system components described below for use in residential, commercial and light-industrial environments:  
erklärt hiermit auf seine alleinige Verantwortung, dass die unten beschriebenen Zubehörteile für das Heizungs-System zur Benutzung im häuslichen, kommerziellen und leicht-industriellen Umfeld:  
déclare par la présente et sous son entière responsabilité que les composants du système de chauffage décrits ci-dessous pour l'utilisation dans des environnements résidentiels, commerciaux et d'industrie légère :  
verklaart hierbij als enige verantwoordelijke dat de componenten van het verwarmingssteem die hieronder worden beschreven, bedoeld zijn voor gebruik in woonomgevingen en in commerciële en licht industriële omgevingen:  
declara por la presente bajo su responsabilidad exclusiva que los componentes del sistema de calefacción descritos a continuación para su uso en zonas residenciales, comerciales y para la industria ligera:  
con la presente dichiara, sotto la sua esclusiva responsabilità, che i componenti dell'impianto di riscaldamento descritto di seguito, destinato all'uso in ambienti residenziali, commerciali e industriali:  
διά του παρόντος δηλώνει υπό αποκλειστική ευθύνη της ότι τα εξαρτήματα του συστήματος θέρμανσης που περιγράφονται παρακάτω για χρήση σε κατοικημένες, εμπορικές και ελαφριές βιομηχανικές περιοχές.  
através da presente declara sob sua única responsabilidade que os componentes do sistema de aquecimento abaixo descritos para uso residencial, comercial e de indústria ligeira:  
erklærer hermed under eneansvar, at de herunder beskrevne komponenter til opvarmning til brug i privat boligbyggeri, erhvervsområder og inden for let industri:  
intygat härmed att uppvärmningssystemkomponenterna som beskrivs nedan är för användning i bostäder, kommersiella miljöer och lätt industri:  
с настоящото декларира на своя отговорност, че описаните по-долу компоненти за отоплителна система са годни за експлоатация в жилищна, търговска и лекопромишлена среда:  
niniejszym oświadczam na swoją wyłączną odpowiedzialność, że klimatyzatory i pompy ciepła opisane poniżej, są przeznaczone do zastosowań w środowisku mieszkalnym, handlowym i lekko przemysłowym:  
erklærer hermed som sitt ansvar, ene og alene, at komponentene i varmesystemet som beskrives nedenfor og som er beregnet for bruk i bolig-, forretnings- og lettindustriemiljøer:  
vakuuttaa täten asiasta yksin vastuussa, että alla kuvattu lämmitysjärjestelmän osat, jotka on tarkoitettu käytettäväksi asuin-, toimisto- ja kevyen teollisuuden ympäristöissä:  
s tem izrecno izjavljamo, da so spodaj opisane komponente ogrevalnega sistema za uporabo v stanovanjskih, poslovnih in lahkoindustrijskih okoljih:  
Prin prezentul document, compania declară pe propria răspundere că piesele sistemului de încălzire descrise mai jos sunt potrivite pentru utilizarea în medii rezidențiale, comerciale și ușor industriale:  
kinnitab oma ainuvastutusele, et allpool kirjeldatud küttesüsteemi komponendid on mõeldud kasutamiseks elu-, kaubandus- ja kergetööstuskeskkonnas:  
ar šo plinībā atbild par to, ka tālāk aprakstītie apsildes sistēmas komponenti, kas izmantojami dzīvojamās, komerciālās un vieglās industriālās vidēs:  
prišiliindamas visą atsakomybę pareiškia, kad žemiau aprašyti šildymo sistemos komponentai skirti naudoti gyvenamojoje, komercinėje ir lengvosios pramonės aplinkose:  
ovime izjavljujemo pod svojom isključivom odgovornošću da su opisane komponente sistema grejanja za upotrebu u stambenim, poslovnim i lakim industrijskim okruženjima:  
ovim izjavljujemo pod svojom isključivom odgovornošću da su opisane komponente sistema grejanja za upotrebu u stambenim, poslovnim i lakim industrijskim okruženjima:

**MITSUBISHI ELECTRIC, EHPT20X-MHEDW**

Note: Its serial number is on the nameplate of the product.  
Hinweis: Die Seriennummer befindet sich auf dem Kennschild des Produkts.  
Remarque : Le numéro de série de l'appareil se trouve sur la plaque du produit.  
Opmerking: het serienummer staat op het naamplaatje van het product.  
Nota: El número de serie se encuentra en la placa que contiene el nombre del producto.  
Nota: Il numero di serie si trova sulla targhetta del prodotto.  
Σημείωση: Ο σειριακός του αριθμός βρίσκεται στην πινακίδα ονόματος του προϊόντος.  
Nota: o número de série encontra-se na placa que contém o nome do produto.  
Bemærk: Serienummeret står på produktets fabriksskilt.  
Obs: Serienumret finns på produktens namnplåt.  
Забелешка: Серийният му номер е на табелката на продукта.  
Uwaga: Numer seryjny znajduje się na tabliczce znamionowej produktu.

Merk: Serienummeret befinner seg på navneplaten til produktet.  
Huomautus: Sarjanumero on merkitty laitteen arvokilpeen.  
Poznámka: Příslušné sériové číslo se nachází na štítku produktu.  
Poznámka: Výrobné číslo sa nachádza na typovom štítku výrobku.  
Megjegyzés: A sorozatszám a termék adattábláján található.  
Opomba: serijska številka je zapisana na tipski ploščici enote.  
Notă: Numărul de serie este specificat pe plăcuța indicatoare a produsului.  
Márkus. Seerianumber asub toote andmesilidil.  
Piezīme. Sērijas numurs ir norādīts uz ierīces datu plāksnītes.  
Pastaba. Serijos numeris nurodytas gaminio vardinų duomenų lentelėje.  
Napomena: serijski broj nalazi se na natpisnoj pločici proizvoda.  
Napomena: Serijski broj nalazi se na nazivnoj pločici proizvoda.

Directives  
Richtlijnen  
Directives  
Richtlijnen  
Directivas  
Direttive

Οδηγίες  
Directivas  
Direktiver  
Direktiv  
Директиви  
Dyrektywy

Direktiver  
Direktiivit  
Směrnice  
Smernice  
Írányelvek  
Direktive

Directive  
Direktiivid  
Direktivas  
Direktyvos  
Direktive  
Direktive

2014/35/EU: Low Voltage  
2006/42/EC: Machinery  
2014/30/EU: Electromagnetic Compatibility  
2009/125/EC: Energy-related Products Directive and Regulation (EU) No 813/2013  
2011/65/EU, (EU) 2015/863 and (EU) 2017/2102: RoHS Directive

Please be sure to put the contact address/telephone number on this manual before handing it to the customer.



**mitsubishi electric corporation**

HEAD OFFICE: TOKYO BUILDING, 2-7-3, MARUNOUCHI, CHIYODA-KU, TOKYO 100-8310, JAPAN