



**2019 HARLEY-DAVIDSON® OWNER'S
MANUAL: BOOM!™ BOX GTS**

©2019 Harley-Davidson Motor Company, Inc
ALL RIGHTS RESERVED
94000601 v.82

**You are viewing a document saved outside of
Harley-Davidson's Service Information Portal.
Click here to view the latest version.**

Model: BBXGTS

REGULATORY AND SAFETY INFORMATION

Exposure to Radio Frequency Radiation

The radiated output power of the internal wireless radio is far below the FCC radio frequency exposure limits. Nevertheless, the wireless radio shall be used in such a manner that the radio is 20 cm or further from the human body.

The internal wireless radio operates within guidelines found in radio frequency safety standards and recommendations, which reflect the consensus of the scientific community.

The radio manufacturer believes the internal wireless radio is safe for use by consumers. The level of energy emitted is far less than the electromagnetic energy emitted by wireless devices such as mobile phones. However, the use of wireless radios may be restricted in some situations or environments, such as aboard airplanes. If you are unsure of restrictions, you are encouraged to ask for authorization before turning on the wireless radio.

This device complies with Part 15 of the FCC Rules and with Industry Canada license-exempt RSS standard(s). Operation is subject to the following two conditions: (1) this device may not cause harmful interference, and (2) this device must accept any interference received, including interference that may cause undesired operation.

Le présent appareil est conforme aux CNR d'Industrie Canada applicables aux appareils radio exempts de licence. L'exploitation est autorisée aux deux conditions suivantes: (1) l'appareil ne doit pas produire de brouillage, et (2) l'utilisateur de l'appareil doit accepter tout brouillage radioélectrique subi, même si le brouillage est susceptible d'en compromettre le fonctionnement.

NOTE: This equipment has been tested and found to comply with the limits for a Class B digital device, pursuant to Part 15 of the FCC Rules. These limits are designed to provide reasonable protection against harmful interference in a residential installation. This equipment generates, uses and can radiate radio frequency energy and, if not installed and used in accordance with the instructions, may cause harmful interference to radio communications. However, there is no guarantee that interference will not occur in a particular installation.

If this equipment does cause harmful interference to radio or television reception, which can be determined by turning the equipment off and on, the user is encouraged to try to correct the interference by one or more of the following measures: (a) Increase the separation between the equipment and receiver. (b) Consult the dealer or an experienced radio technician for help.

This device complies with IC radiation exposure limits set forth for an uncontrolled environment. The device should be installed and operated with a minimum distance of 20cm between the radiator and your body. This device must not be collocated or operating in conjunction with any other antenna or transmitter.

Information accurate as of January 28th, 2019. Go to <https://serviceinfo.harley-davidson.com> to check for the latest version.



DECLARATION OF CONFORMITY

The EC Declaration of Conformity is available at www.harman.com/EN-US/ContactUs/Pages/Compliance.aspx.

English

Hereby, Harman Becker Automotive Systems, Inc., declares that this device is in compliance with the essential requirements and other relevant provisions of Directive 1999/5/EC.

Česky [Czech]

Harman Becker Automotive Systems, Inc. tímto prohlašuje, že toto zařízení je ve shodě se základními požadavky a dalšími příslušnými ustanoveními směrnice 1999/5/ES.

Dansk [Danish]

Undertegnede Harman Becker Automotive Systems, Inc. erklærer herved, at følgende udstyr anordning overholder de væsentlige krav og øvrige relevante krav i direktiv 1999/5/EF.

Deutsch [German]

Hiermit erklärt Harman Becker Automotive Systems, Inc., dass sich das Gerät in Übereinstimmung mit den grundlegenden Anforderungen und den übrigen einschlägigen Bestimmungen der Richtlinie 1999/5/EG befindet.

Eesti [Estonian]

Käesolevaga kinnitab Harman Becker Automotive Systems, Inc. et käesolev seade vastab direktiivi 1999/5/EÜ põhinõuetele ja teistele asjakohastele sätetele.

Español [Spanish]

Por medio de la presente Harman Becker Automotive Systems, Inc. declara que el dispositivo cumple con los requisitos esenciales y cualesquiera otras disposiciones aplicables o exigibles de la Directiva 1999/5/CE.

Ελληνική [Greek]

ΜΕ ΤΗΝ ΠΑΡΟΥΣΑ Harman Becker Automotive Systems, Inc. ΔΗΛΩΝΕΙ ΟΤΙ Η ΣΥΣΚΕΥΗ ΣΥΜΜΟΡΦΩΝΕΤΑΙ ΠΡΟΣ ΤΙΣ ΟΥΣΙΩΔΕΙΣ ΑΠΑΙΤΗΣΕΙΣ ΚΑΙ ΤΙΣ ΛΟΙΠΕΣ ΣΧΕΤΙΚΕΣ ΔΙΑΤΑΞΕΙΣ ΤΗΣ ΟΔΗΓΙΑΣ 1999/5/ΕΚ.

Information accurate as of January 28th, 2019. Go to <https://serviceinfo.harley-davidson.com> to check for the latest version.

Français [French]

Par la présente Harman Becker Automotive Systems, Inc. déclare que ce dispositif est conforme aux exigences essentielles et aux autres dispositions pertinentes de la directive 1999/5/CE.

Italiano [Italian]

Con la presente Harman Becker Automotive Systems, Inc. dichiara che questo dispositivo è conforme ai requisiti essenziali ed alle altre disposizioni pertinenti stabilite dalla direttiva 1999/5/CE.

Latviski [Latvian]

Ar šo Harman Becker Automotive Systems, Inc. deklarē, ka ierīce atbilst Direktīvas 1999/5/EK būtiskajām prasībām un citiem ar to saistītajiem noteikumiem.

Lietuvių [Lithuanian]

Šiuo Harman Becker Automotive Systems, Inc. deklaruoja, kad šis įrenginys atitinka esminius reikalavimus ir kitas 1999/5/EB Direktyvos nuostatas.

Nederlands [Dutch]

Hierbij verklaart Harman Becker Automotive Systems, Inc. dat het toestel in overeenstemming is met de essentiële eisen en de andere relevante bepalingen van richtlijn 1999/5/EG.

Malti [Maltese]

Hawnhekk, Harman Becker Automotive Systems, Inc., tidlikjara li dan il-prodott jikkonforma mar-rekwiziti essenzjali u ma' dispozizzjonijiet oħrajn relevanti li hemm fid-Direttiva 1999/5/KE.

Magyar [Hungarian]

Alulírott, Harman Becker Automotive Systems, Inc. nyilatkozom, hogy a készülék megfelel a vonatkozó alapvető követelményeknek és az 1999/5/EC irányelv egyéb előírásainak.

Polski [Polish]

Niniejszym Harman Becker Automotive Systems, Inc. oświadcza, że urządzenie jest zgodne z zasadniczymi wymogami oraz pozostałymi stosownymi postanowieniami Dyrektywy 1999/5/WE.

Information accurate as of January 28th, 2019. Go to <https://serviceinfo.harley-davidson.com> to check for the latest version.

Português [Portuguese]

Harman Becker Automotive Systems, Inc. declara que este dispositivo está conforme com os requisitos essenciais e outras disposições da Directiva 1999/5/CE.

Slovensko [Slovenian]

Harman Becker Automotive Systems, Inc. izjavlja, da je ta izdelek v skladu z bistvenimi zahtevami in ostalimi relevantnimi določili direktive 1999/5/ES.

Slovensky [Slovak]

Harman Becker Automotive Systems, Inc. týmto vyhlasuje, že zariadenie spĺňa základné požiadavky a všetky príslušné ustanovenia Smernice 1999/5/ES.

Suomi [Finnish]

Harman Becker Automotive Systems, Inc. vakuuttaa täten, että tämä laite on direktiivin 1999/5/EY oleellisten vaatimusten ja sitä koskevien direktiivin muiden ehtojen mukainen.

Svenska [Swedish]

Härmed intygar Harman Becker Automotive Systems, Inc. att denna apparat står i överensstämmelse med de väsentliga egenskapskrav och övriga relevanta bestämmelser som framgår av direktiv 1999/5/EG.

Íslenska [Icelandic]

Hér með lýsir Harman Becker Automotive Systems, Inc. yfir því að tæki þetta er í samræmi við grunnkröfur og aðrar kröfur, sem gerðar eru í tilskipun 1999/5/EC.

Norsk [Norwegian]

Harman Becker Automotive Systems, Inc. erklærer herved at denne enheten er i samsvar med de grunnleggende krav og øvrige relevante krav i direktiv 1999/5/EF.

© 2019 H-D, 05/23/2019

TABLE OF CONTENTS

INTRODUCTION

Your Owner's Manual.....	1
Customer Service Assistance.....	1

SAFETY FIRST

Safety Definitions.....	3
Safety Information.....	3
Navigation.....	5
Pre-Ride Checklist.....	5
Emergency Phone Number.....	6
Emergency CB Operation.....	6
Thermal Power Down.....	6

QUICK START GUIDE

Basic Operation.....	7
SAFETY.....	7
CONTROLS.....	8
BASIC OPERATION.....	12
RADIO.....	13
SETUP.....	14
BLUETOOTH.....	15
PHONE.....	16
VOICE RECOGNITION.....	16
NAVIGATION SYSTEM.....	17

FEATURES AND SPECIFICATIONS

Acronyms Used in this Manual.....	21
Definitions Used in this Manual.....	21
Breadcrumbs.....	21
Media Filters.....	21
Menu Icon.....	22
Multi-page Indicator.....	22
SiriusXM Categories Icon.....	23
Station Categories Icon.....	23
Specifications.....	24

CONTROLS AND COMPONENTS

Touchscreen.....	33
Home.....	34
Audio.....	34
Navigation.....	34
Phone.....	34
Information (Vehicle Status).....	34
Power/Mute.....	34
Setup.....	35
Communications.....	35
Favorites.....	36
Audio Settings.....	36
Left Hand Control.....	37
Right Hand Control.....	39

TABLE OF CONTENTS

Rear (Passenger) Controls.....	41	Keyboard.....	54
MODE/UP/DN Switch.....	41	Smart Speller.....	56
Push-To-Talk (PTT)/Volume (VOL) Switch.....	41	Volume Controls.....	56
Enabling Rear Controls.....	41	Popup Screens.....	57
Headset Connection.....	42	Lockout Screens.....	57
Microphone Positioning.....	43	Status Bar.....	57
Media Compartment: USB Port.....	44	System Setup.....	59
Media Compartment: Fixed Fairing Vehicles.....	45	Setup Menu.....	60
Media Compartment: Fork Mounted Fairing Vehicles.....	46	Language.....	62
Speakers.....	46	Screen Brightness.....	62
Fairing Speakers.....	47	Button Brightness.....	63
Fairing Lower Speakers.....	47	Colors.....	63
Saddlebag Speakers.....	47	Colors.....	63
Tour-Pak Speakers.....	47	Theme.....	63
Amplifier.....	47	High Contrast.....	64
Antennas and Reception.....	47	English Units/Metric.....	64
Bluetooth.....	48	Clock.....	64
Turning Motorcycle On, Off or to Accessory Mode.....	49	Speaker/Headset Selection.....	65
Disconnecting the Vehicle Battery.....	49	Audio Settings: Bass/Treble.....	66
SETUP		Fade.....	66
Home Screen.....	51	Speed Volume.....	67
Screen Menu Bar.....	52	Feedback Prompts.....	68
Checkbox and Multiselect.....	52	Rear Controls.....	68
Scroll Controls.....	53	Global Presets.....	68
		Bluetooth.....	70

TABLE OF CONTENTS

Ring Tones.....	70	Weather Alert.....	82
SiriusXM.....	70	Media.....	83
Traffic.....	70	Media Screen.....	83
System Information.....	70	Media Devices.....	84
Software Updates.....	72	Connecting Media Device: USB.....	85
Confirm Software.....	72	Connecting Media Device: Bluetooth.....	86
Update Software.....	72	Device Players and Applications: Bluetooth.....	86
Privacy Reset.....	74	Selecting Media Device.....	86
Factory Restore.....	74	Play Previous/Next Media File: Previous/Next.....	87
AUDIO		Play Previous/Next Media File: Preset.....	87
AM-FM-WB Radio.....	75	Pause, Rewind or Fast Forward Media File.....	87
Tuner.....	75	Scanning Media Files.....	87
Selecting a Band.....	75	Repeat Current File.....	88
Selecting a Band: Voice Recognition.....	76	Play Random Files: Shuffle.....	88
Tune/Seek/Preset Stations.....	76	Play Songs From Track List.....	88
Tuning a Station: Voice Recognition.....	76	Media Presets.....	89
Seeking a Station: Voice Recognition.....	77	Finding a Media File.....	89
Scanning Stations.....	77	Finding a Media File: Playlist.....	90
Presets.....	77	Finding a Media File: Artist, Album, Genre or Composer.....	91
Categories.....	77	Finding a Media File: Song Title.....	91
Selecting Categories.....	78	Finding a Media File: Podcast.....	91
Station List (EU).....	80	Finding a Media File: Audio Book.....	92
RBDS/RDS.....	80	Finding a Media File: Video, TV Show, Movie, Music Video.....	92
Enable RDS/RBDS.....	81	Selecting Media File: Using Voice Recognition.....	93
Weather Band.....	81		

TABLE OF CONTENTS

Saving Media File as Favorite.....	93	Displaying Weather.....	103
Saving Media File as Ring Tone.....	93	SiriusXM Weather Map.....	106
Satellite Radio.....	93	Weather Map Scrolling.....	106
SiriusXM Satellite Radio.....	93	Weather Map Radar and Fronts.....	106
Optional SiriusXM Accessory.....	94	Display Last Weather Update.....	108
Trial Subscription.....	94	SiriusXM Fuel Prices.....	108
Check Subscription Status.....	94	Selecting Fuel Type.....	108
Subscribing to SiriusXM.....	95	Viewing Fuel Prices.....	108
Listening to SiriusXM Radio.....	95	SiriusXM Traffic.....	110
SiriusXM Presets.....	96	Turning Traffic On.....	111
Selecting a Channel: Hand Controls.....	96	Traffic Notification Popups.....	111
Selecting a Channel: Channel List.....	96	Traffic Icons.....	111
Selecting a Channel: Direct Tune.....	96	Traffic Reroute.....	111
Selecting a Channel: Voice Recognition.....	97	Traffic Message List.....	111
Scanning SiriusXM Channels.....	97	Bluetooth.....	112
Tagging an Artist or Song.....	98	Enabling Bluetooth.....	112
Viewing Tagged List.....	99	Pairing a Bluetooth Device.....	113
Tag Alert.....	99	Listening to Music.....	114
SiriusXM Categories.....	100	Connecting/Disconnecting a Bluetooth Device.....	115
Game Zone.....	100	Reconnecting After Vehicle Turns On.....	116
Enabling Sports Alerts.....	100	Deleting a Paired Device.....	116
Adding a Game Zone Favorite.....	101		
Setting Game or Score Notification.....	102	CARE AND CLEANING	
Responding To Game Zone Alert.....	103	Audio System Care.....	117
Removing a Game Zone Favorite.....	103	Screen.....	117

TABLE OF CONTENTS

Cleaning the Radio.....	117	Voice Mail.....	126
Speaker Care.....	117	Phone Book.....	126
PHONE		Phone Book.....	126
Phone Compatibility.....	119	Setting Up Contacts in a Phone.....	126
Bluetooth and USB Connections For Phones.....	119	Refresh Phone Book.....	127
Phone Menu.....	119	Showing Contact Details.....	127
Call Screen.....	120	Viewing Saved Contacts and Phone Numbers.....	127
iPhone: Using Siri.....	121	Saving a Phone Book Contact.....	128
Making a Call.....	121	Saving a Dialed Phone Number.....	128
Dialing.....	121	Saving Phone Number from Current Call.....	128
Phone Book Contact.....	123	Delete Saved Contact.....	128
Navigation POI.....	123	Call History.....	128
SiriusXM Gas Station.....	123	Text Messaging.....	129
Emergency Phone Number.....	123	Enabling Text Messaging: SMS.....	129
Dialing with Voice Recognition.....	123	Enabling New Message Pop-Up.....	129
Calling a Contact with Voice Recognition.....	124	Text Message (SMS) Auto-reply.....	130
Receiving a Call.....	124	Viewing/Playing A Text Message.....	130
Accepting/Ignoring.....	124	Enabling Text Message Notification: Apple Devices...	131
Radio Turned Off.....	124	Ring Tone.....	132
Call Options.....	125	Selecting.....	132
Ending a Call.....	125	Adding New Ring Tone: USB.....	132
Adjusting Call Volume.....	125	Resuming Calls After Vehicle Shutdown.....	132
Muting Call Audio.....	125	Transferring a Call Back to the Phone.....	133
Routing Call Audio.....	125	Changing the Emergency Phone Number.....	133
Multiple Calls.....	125	Apple CarPlay.....	134

TABLE OF CONTENTS

NAVIGATION

Navigation.....	137	Route To Destination: Dealership.....	149
One Box Search (OBS).....	137	Route To Destination: Emergency.....	149
Map Compass Setting.....	138	Route To Destination: Coordinates.....	150
Full-Size Compass (equipped without Navigation).....	138	Route to Destination: Fuel.....	150
Map.....	139	Route To Destination: Voice Command.....	152
Display Map.....	139	Route to Destination: Repeat Navigation Instruction...	152
Change Map Settings.....	140	Canceling or Pausing a Route: Using Menu.....	152
Change Nav Settings.....	142	Canceling a Route: Voice Command.....	153
Change Data Field.....	144	Showing a Planned Route.....	153
Map Navigation Option Menu.....	144	Simulating a Route.....	153
Route Preferences and Avoidances.....	144	Calling a Destination: Route Active.....	154
Auto zoom.....	145	Calling a Destination: Route Not Active.....	154
Map Scrolling: Touchscreen.....	145	Saving A Destination.....	154
Map Scrolling: Hand Controls.....	145	Saving A Destination: Home.....	155
Selecting POI on Map.....	146	Saving Current Location.....	155
Route.....	147	Rides.....	155
Route To Destination: Address.....	147	Creating a Ride: Using Menus.....	155
Route To Destination: Home.....	148	Creating a Ride: Using Map.....	156
Route To Destination: Recent.....	148	Round Trip.....	156
Route To Destination: Contacts.....	148	Editing a Ride: Adding Waypoints In Menu.....	156
Route To Destination: Saved.....	148	Editing a Ride: Adding Waypoints On Map.....	157
Route To Destination: Map Scroll Tool.....	149	Editing a Ride: Reordering Waypoint.....	157
Route To Destination: POI.....	149	Editing a Ride: Skipping Next Waypoint.....	159
		Editing a Ride: Skipping Waypoint.....	160
		Trails.....	160

TABLE OF CONTENTS

Record a Trail.....	160
Rename a Trail.....	161
Navigating a Trail.....	161
Deleting a Trail.....	161
Exporting a Route.....	161
Importing a Route.....	162
USB Drive.....	163
Mobile App.....	163
Traffic.....	164
Turning Traffic On/Off.....	165
Traffic Notification Settings.....	165
Rerouting.....	166
Traffic Event List: RDS Traffic.....	166
Maneuvers: Turn-By-Turn Instructions.....	167
Maneuvers: Avoid a Road.....	168
Maneuvers: Zoom.....	168
Maneuvers: Restoring an Avoided Road.....	169
Lane Guidance.....	170
Trip Summary.....	171
Low Fuel Alert.....	172
GPS Information.....	172
Navigation Prompts.....	172
Navigation Prompts: Turning On/Off.....	172
Navigation Prompts: Adjusting Volume Using Menus.....	173
Navigation Prompts: Adjusting Volume with Hand Controls.....	173

Navigation Prompts: Speaker/Headset Selection.....	173
Navigation Database and Software.....	173
Ride Planner.....	174

COMMUNICATIONS

Voice Recognition.....	179
Voice Recognition.....	179
Activating Voice Recognition.....	179
Canceling Voice Recognition.....	179
Teleprompter.....	180
Command List.....	180
Pick List.....	180
Prompter Responds "Pardon?".....	181
Voice Recognition Commands.....	181
Intercom.....	185
Turning Intercom On/Off.....	185
Adjusting Microphone Sensitivity: VOX.....	186
Speed Volume.....	186
Adjusting Intercom Volume: Rider and Passenger Headsets.....	186
Operating Intercom: Voice Activation, VOX.....	187
Operating Intercom: PTT Switch.....	187
Whim.....	188
Getting Started.....	188
Powering On and Off.....	188
Wireless Headset Setup.....	189

TABLE OF CONTENTS

Headset to Headset Intercom Pairing.....	191
Headset Configurations.....	191
Headset Software Version.....	193
Unpair Wireless Headset.....	193
Reset Factory Headset Settings.....	194
Fault Reset.....	194
Citizen Band (CB) Radio.....	195
Turning CB On.....	196
Turning CB Off.....	196
Conflicting Transmissions.....	197
Emergency Operation: Channel 9.....	197
Transmitting on CB.....	197
Receiving CB Audio.....	198
Tuning CB Channels.....	198
CB Presets.....	199
Squelch.....	199
CB Volume.....	200
Passenger CB Operation.....	200
Factors Affecting CB Range.....	201
Adding an Optional CB Module.....	201

FAVORITES

Favorites.....	203
Setting a Favorite.....	203
Selecting a Favorite.....	203

OTHER FEATURES

Waiting Popup.....	205
Next Letter Jumping.....	205
Popups.....	206
Quick Keys.....	206
Quick Jump.....	206
High Contrast.....	207
Projection Mode.....	207

INFORMATION (VEHICLE STATUS)

Vehicle Status.....	209
Information.....	209
Engine Information.....	209
Reset Last Service.....	210
Tire Pressure Monitoring System (TPMS).....	210
Low Tire Pressure Alert.....	211
Trip Summary.....	212

FCC CITIZENS BAND INFORMATION

What Every Responsible Citizens Band (CB) Station Operator Should Know as Prepared by the Federal Communications Commission, Washington, D.C.....	213
Subpart D-Citizens Band (CB) Radio Service General Provisions.....	213

TABLE OF CONTENTS

How to Operate a CB Station.....	215	Your Consumer Rights.....	227
Other Things You Need to Know.....	221	Warranty.....	227
LIMITED RADIO WARRANTY		Warranty Period.....	227
2019 LIMITED RADIO WARRANTY.....	225	Exclusions.....	228
Other Rights.....	226	Obtaining Warranty Service.....	228
LIMITED RADIO WARRANTY (AUSTRALIA)		APPENDIX	
2019 AUSTRALIA/NEW ZEALAND LIMITED RADIO WARRANTY.....	227	H-D U.S.A., LLC Trademark Information.....	229
		Product Registered Marks.....	229

© 2019 H-D, 05/01/2019

NOTES

© 2019 H-D, 05/23/2019

YOUR OWNER'S MANUAL

This manual has been prepared to acquaint you with the operation, care and maintenance of your motorcycle. It also provides important safety information. Follow these instructions carefully for maximum motorcycle performance and for your personal motorcycling safety and pleasure.

Your owner's manual contains instructions for operation and minor maintenance. Major repairs are covered in the Harley-Davidson service manual. Major repairs require the attention of a skilled technician and the use of special tools and equipment. Your Harley-Davidson dealer has the facilities, experience and Genuine Harley-Davidson parts necessary to render this valuable service. We recommend that any emission system maintenance be performed by an authorized Harley-Davidson dealer.

Harley-Davidson reserves the right to change specifications, equipment or designs at any time without notice and without incurring obligation.

This owner's manual should be considered a permanent part of the motorcycle and should remain with the motorcycle if it is resold.

CUSTOMER SERVICE ASSISTANCE

Most sales or service issues are resolved at the dealership.

1. Discuss your problem with the appropriate personnel at the dealership in the Sales, Service or Parts area. If that proves unsuccessful, speak to the owner of the dealership or the general manager.
2. If you cannot resolve the issue with the dealership, contact the Harley-Davidson Customer Support Center. Harley-Davidson Motor Company Attention: Harley-Davidson Customer Support Center P.O. Box 653 Milwaukee, Wisconsin 53201 1-800-258-2464 (U.S. only) 1-414-343-4056

For customers outside the US, contact your local Harley-Davidson market office, call 1-414-343-4056 or visit harley-davidson.com.

Table 1. Vehicle and Personal Data

PERSONAL INFORMATION	DEALER INFORMATION
Date of Purchase:	
Name:	Name:
Address:	Address:
Address:	Address:
Vehicle Identification Number:	Sales Contact:
Key Number:	Service Contact:

SAFETY DEFINITIONS

Statements in this manual preceded by the following words are of special significance:

▲ WARNING

WARNING indicates a potentially hazardous situation which, if not avoided, could result in death or serious injury. (00119a)

▲ CAUTION

CAUTION indicates a potentially hazardous situation which, if not avoided, may result in minor or moderate injury. (00139a)

NOTICE

NOTICE indicates a potentially hazardous situation which, if not avoided, may result in property damage. (00140b)

NOTE

Refers to important information and is placed in italic type. It is recommended that you take special notice of these items.

SAFETY INFORMATION

▲ WARNING

Set volume levels and other controls on audio and electronic devices before riding. Distractions can lead to loss of control, resulting in death or serious injury. (00088b)

▲ WARNING

Set CB channel, squelch threshold and volume before riding to minimize adjustments on the road. Distractions can lead to loss of control, resulting in death or serious injury. (00089a)

▲ WARNING

Do not select a volume level that blocks out traffic noise or interrupts the concentration necessary for safe operation of the motorcycle. Distractions or a volume level that blocks out traffic noise could cause loss of control resulting in death or serious injury. (00539b)

NOTICE

There are no serviceable parts inside the unit; leave all servicing to qualified service personnel. Disassembly of the unit could result in equipment damage and/or equipment malfunction. (00172a)

This manual explains the operation of the Boom!™ Box Infotainment system. Investing time to learn about the features and operation of your motorcycle and its infotainment system will lead to safe enjoyable use of its full range of features. Read this manual carefully and keep it with your motorcycle at all times for reference. An online copy of this manual is available at serviceinfo.harley-davidson.com.

See the owner's manual for your vehicle for important rider safety information.

Follow all the warnings, cautions and safety tips shown throughout this manual and your vehicle manual.

See Figure 1. Do not use any feature of this system to the extent it becomes a distraction and prevents safe riding. The first priority while riding should always be the safe operation of the vehicle. While riding, observe all traffic regulations.

NOTE

The acceptance screen will clear after 15 seconds if ACCEPT is not selected.

Pay attention while riding. Always concentrate on riding by keeping your eyes and mind on the road. To prevent distraction, some features are locked out, unavailable or limited in capability while the motorcycle is in motion. Even if a feature is available, do not allow it to distract you from operating the motorcycle safely.

For safety, program the system when stopped. Perform system setup and get familiar with the controls and features of the infotainment system before operating the motorcycle on the road.

This system cannot warn about such things as the safety of an area, road conditions and availability of emergency services.

Use this system only in locations where it is legal to do so.

For additional instruction and information for setting up or operating the system, see an authorized Harley-Davidson dealer and online resources at serviceinfo.harley-davidson.com.

4 Safety First

Information accurate as of January 28th, 2019. Go to <https://serviceinfo.harley-davidson.com> to check for the latest version.

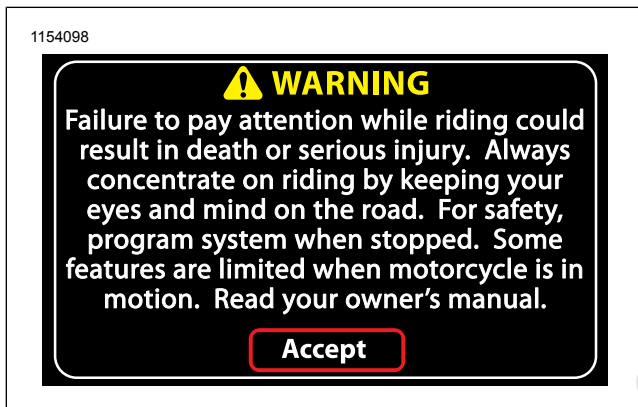

Figure 1. Warning and Acceptance

NAVIGATION

The navigation, lane guidance and traffic features are intended to assist you when traveling. Always use personal judgment and observation of the actual road conditions while riding. In some circumstances, information provided in the navigation database may be incomplete, incorrect or outdated. Road conditions, traffic laws and restrictions (such as no left turns, street closures, one way streets, road construction detours, and so on) can frequently change. Before following any instruction from the system, check whether the instruction can be done safely and legally.

If necessary, safely park the vehicle if there is difficulty following the route guidance or if there is a need to program a new route. In some circumstances, the system could temporarily provide an inaccurate position of the vehicle or show errors in distance between objects.

When importing routes from other devices or websites, understand that there may be limitations to the accuracy or reliability of the imported data. There may also be compatibility limitations when importing data files from another device or website.

Program and review navigation routes with the vehicle stopped. When taking a long trip, plan and review the route before riding the motorcycle. Install updates to the navigation database to make sure you have the latest information available.

PRE-RIDE CHECKLIST

To make full use of features and minimize distraction while on the road, configure the system with your personal preferences before riding.

- Set brightness, background color and day/night color mode.
- Configure presets and favorites.
- Adjust audio settings (volume, tone, fade and headset/speaker selection).
- Pair, connect and set up phone features through Bluetooth.

- Connect USB devices.
- Select station or media.
- Set up rides and navigation.
- Set up CB and intercom.
- Connect and put on headsets.

EMERGENCY PHONE NUMBER

Setting up an emergency phone number can provide access to help when needed. See Making a Call (Page 121).

Phone numbers and navigation to nearby emergency resources are also available on equipped systems. See Route (Page 147).

EMERGENCY CB OPERATION

For vehicles equipped with a CB, channel 9 is reserved for emergency use in most countries. When using this channel for emergencies or assistance, clearly identify the nature of the problem and your location. If no response is received, try other channels or find another way to get help.

THERMAL POWER DOWN

See Figure 2. If a thermal issue is detected by the radio, a warning screen displays **Radio Temperature Too High, Shutting Down**. System shutdown will start automatically 15 seconds after the screen first displayed the warning.

Allow a five minute cool down period. Restart the radio. If the restart fails, allow a longer cooling period.

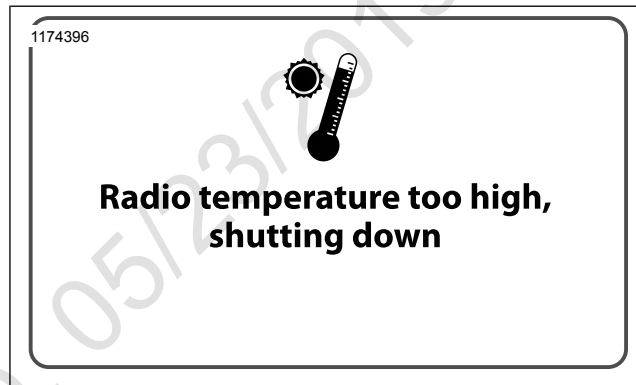

Figure 2. Thermal Shut Down Screen

BASIC OPERATION

SAFETY

Follow all warnings, cautions and safety tips in this Quick Start Guide, vehicle owner's manual and **Boom! Box** owner's manual.

⚠ WARNING

Set volume levels and other controls on audio and electronic devices before riding. Distractions can lead to loss of control, resulting in death or serious injury. (00088b)

⚠ WARNING

Set CB channel, squelch threshold and volume before riding to minimize adjustments on the road. Distractions can lead to loss of control, resulting in death or serious injury. (00089a)

⚠ WARNING

Do not select a volume level that blocks out traffic noise or interrupts the concentration necessary for safe operation of the motorcycle. Distractions or a volume level that blocks out traffic noise could cause loss of control resulting in death or serious injury. (00539b)

NOTICE

There are no serviceable parts inside the unit; leave all servicing to qualified service personnel. Disassembly of the unit could result in equipment damage and/or equipment malfunction. (00172a)

CONTROLS

Faceplate

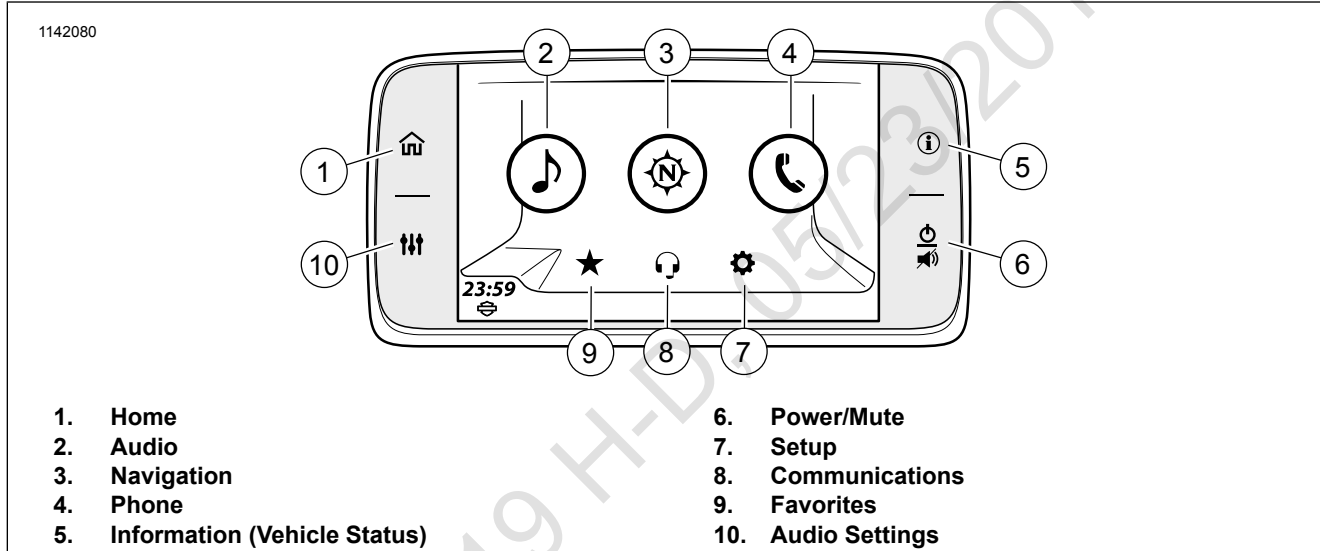

Figure 3. Faceplate Home Screen Selections

Table 2. Faceplate Home Screen Selections

Press	Result
1 [Home]	Displays Home screen. Toggle between Home screen and active media.
	Available selections: Audio, Navigation, Phone, Setup, Communications, Favorites.

Table 2. Faceplate Home Screen Selections

Press	Result
2 [Audio]	Displays active source with audible content information. Available selections: FM, AM, WB (weather band). Optional selections: When connected: iPod, USB Media, Bluetooth Audio. If equipped: SiriusXM.
3 [Navigation]	Displays map with current position. Available selections: Search, Menu, Stop Route, Highway Services (shows only on highways), Data Wing (right and left), Zoom (in and out). Informational display: Current Street, Compass, Next Maneuver, Distance to Next Maneuver, Next Street, Repeat.
4 [Phone]	Displays menus for staying connected. Available selections: Calls, Contacts, Messages, Keypad, SOS.
5 [Info]	Displays vehicle status. Available selections: Info, Engine/Fuel Info, Ride Summary, TPMS (CVO only).
6 [Mute/Power]	Toggles power on and off (hold for three seconds). Silence or pause audio.
7 [Setup]	Configure system settings. Do before riding the motorcycle. Available selections: Audio Settings, Display, Global Presets, Keyboard, Bluetooth setup, Wireless Headset, Units, Clock, Rear Controls, System Information, Language, Projection Mode.
8 [Communication]	Displays enabled communication devices. Available selections: Intercom (when enabled), Citizen Band (CB, if equipped).
9 [Favorites]	Displays saved favorites. Available selections: Tuner, Media, Phone, Destination.
10 [Audio Setup]	Displays audio setting screen. Available selections: Bass, Treble, Audio Routing, Fade, Volumes.

Left Hand Control

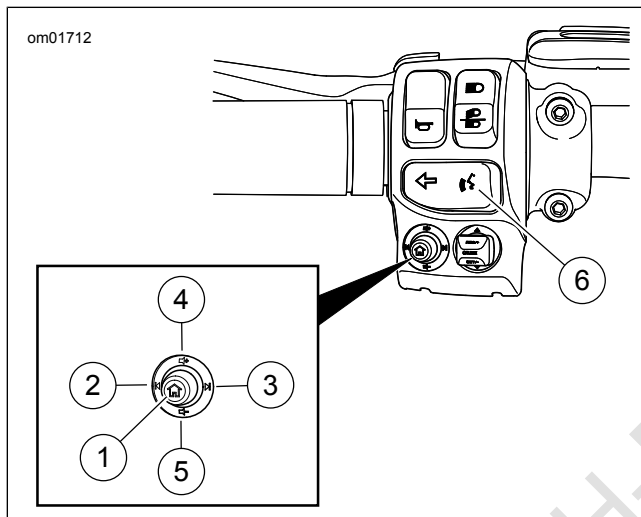

Figure 4. Left Hand Control Audio Functions (typical)

Table 3. Left Hand Control Audio Functions

ITEM	ICON	NAME	FUNCTION
1		Home	Short Press: Toggles between current screen and Home screen. Long Press: Toggles the Quick Jump screen.
2		Previous /Seek Down	Media: Previous media file. Tuner: Tune/seek down.
3		Next/Seek Up	Media: Next media file. Tuner: Tune/seek up.
4		Volume Up	Increases volume.
5		Volume down	Decreases volume.
6		Voice Recognition	Initiates a voice recognition session. Also, a long press initiates Siri for Bluetooth paired iPhone or Apple CarPlay when a headset is connected.

Quick Jump

On the left hand control perform a long press on the Home button. This displays the Quick jump screen.

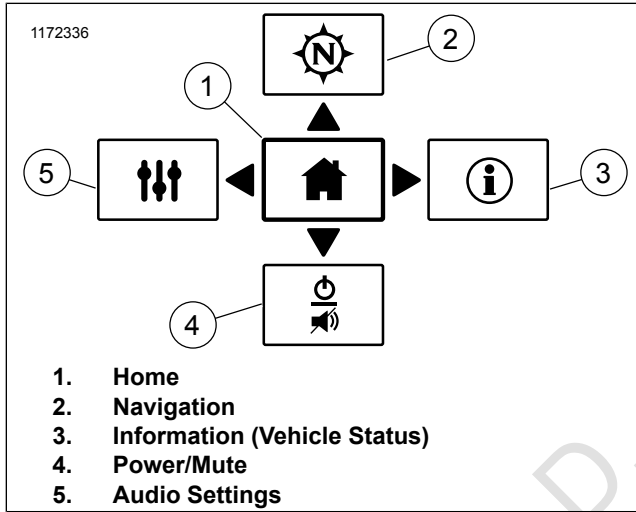

Figure 5. Quick Jump

Right Hand Controls

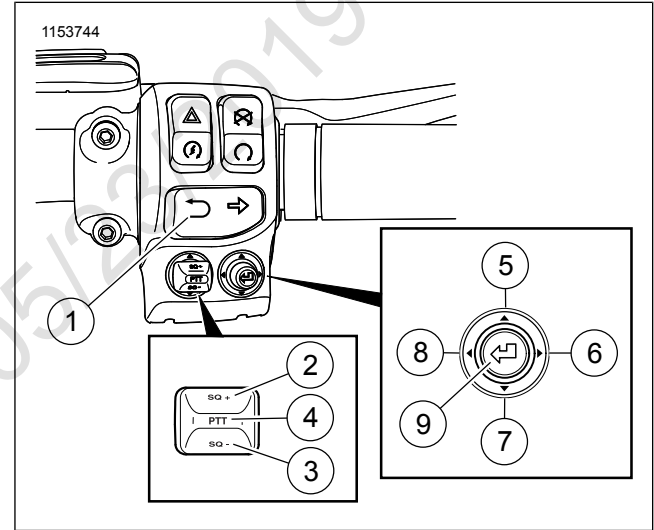







Figure 6. Right Hand Control Audio Functions

Table 4. Right Hand Control Audio Functions

ITEM	ICON	NAME	FUNCTION
1		Back	Short Press: Back to previous screen. Long Press: Screen transitions between normal day color and high contrast color.
2	SQ +	CB Squelch +	Increases CB squelch level (if equipped).
3	SQ -	CB Squelch -	Decreases CB squelch level (if equipped).
4	PTT	CB Push to Talk	Press and hold to transmit on CB/intercom (if equipped).
5		Cursor Up	Moves the highlighting up through the selections.
6		Cursor Right	Moves the highlighting right through the selections. Tuner: Next preset up.
7		Cursor Down	Moves the highlighting down through the selections.
8		Cursor Left	Moves the highlighting left through the selections. Tuner: Next preset down.
9		Select /Enter	Selects highlighted item.

BASIC OPERATION

Turning System ON/OFF

NOTE

To mute or unmute audio, briefly press Power/ Mute (1).

1. Switch power to Accessory, Ignition or Run (CVO).
2. See Figure 7. To power ON radio, press Power/Mute (1).

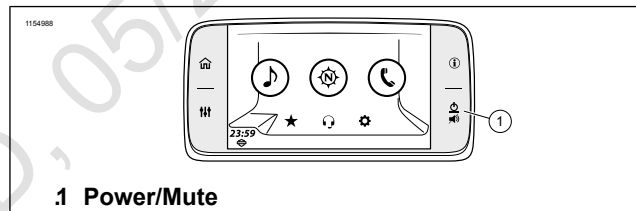

1 Power/Mute

Figure 7. Turning System ON/OFF

3. See Figure 8. Read the warning and select Accept.

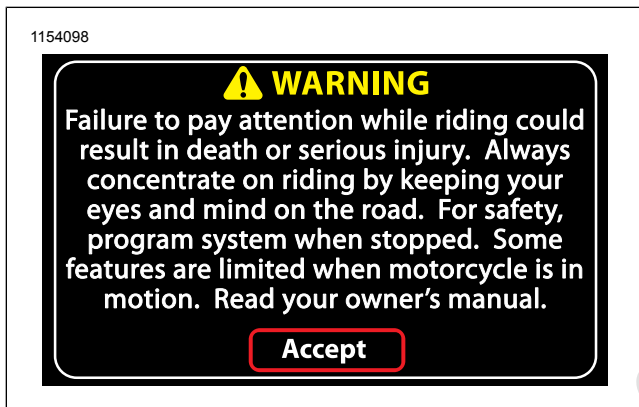

Figure 8. Warning and Accept

4. To power OFF radio, press and hold Power/Mute (1) button for 3 seconds.

RADIO

Select Source

1. **Navigate:** Home > Audio.

2. See Figure 9. **Select:** Source field.
 - a. **Tuner:** AM - FM - WB (selections vary for European Union).
 - b. **Media:** USB (when connected), phone (Bluetooth), SiriusXM (if equipped).

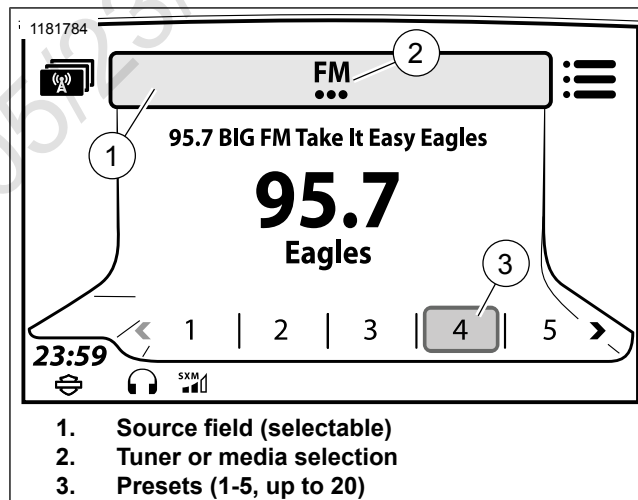

Figure 9. Source Selection

1. **Source field (selectable)**
2. **Tuner or media selection**
3. **Presets (1-5, up to 20)**

Seek and Save Station

1. See Figure 10. **Select:** Seek Down (1) or Seek Up (2) on left hand control.
2. See Figure 9. Press screen and hold preset until it beeps.

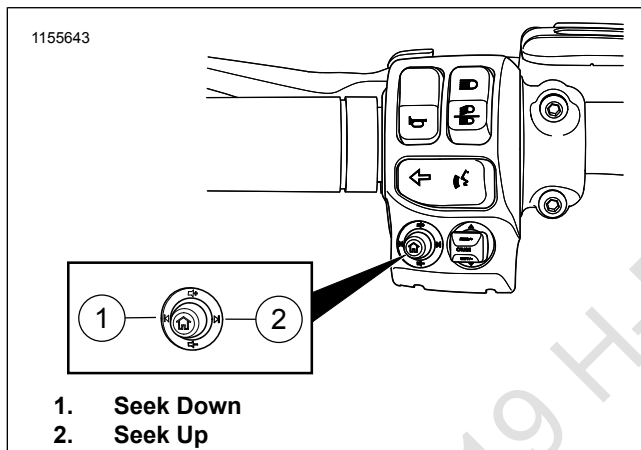

Figure 10. Radio Station Seek

SETUP

NOTE

The **Audio Settings** button on the radio's faceplate can be as a shortcut to make the same adjustments.

Audio Settings

1. **Navigate:** Home > Setup > Audio Settings.
2. **Adjust:** Bass or Treble.

Select Speakers or Headsets (if equipped with headset)

1. **Navigate:** Home > Setup > Audio Settings > Audio Routing.
2. See Figure 11. **Select:** Speaker or Headset.

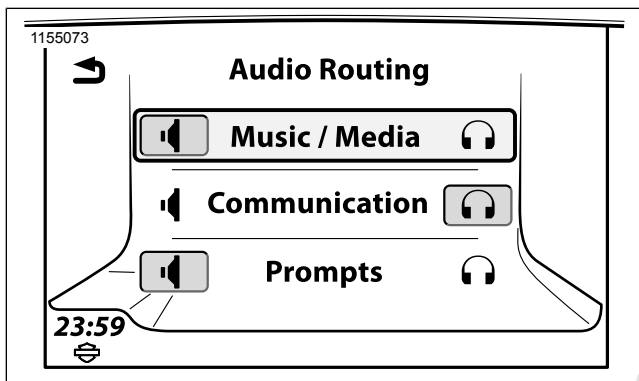

Figure 11. Speaker or Headset

Speaker Volumes

1. **Navigate:** Home > Setup > Audio Settings > Speaker Volumes.
2. **Adjust:** Media/Tuner, Prompt Nav, Phone, CB, Beep.

BLUETOOTH

Pair Phone or Other Device

1. Activate Bluetooth on your device.

2. **Navigate:** Home > Phone.
3. **Prompt:** No device connected. Would you like to connect a device?
 - a. **Select:** Yes.
4. **Select:** Add new device.
5. **Prompt:** Does PIN match on device?
 - a. Check PINs (auto-generated) on audio system and device.
 - b. **Select:** Yes (if numbers match).
6. **Prompt:** Would you like to set an Emergency number?
 - a. **Select:** Yes or No.

Streaming Audio

NOTE

The device must first be paired with the Boom! Audio system before it can be used. See Bluetooth (Page 112). Device must also support Bluetooth audio streaming profile.

1. **Navigate:** Home > Audio.
2. See Figure 9. **Select:** Source field.
3. **Select:** Phone (Bluetooth).

PHONE

Making a Call

NOTE

- The phone must first be paired with the audio system before it can be used through the Boom! Box infotainment system. See Bluetooth (Page 112).
- A Harley-Davidson headset with microphone is required to make and receive calls via Bluetooth.

1. **Navigate:** Home > Phone.
2. See Figure 12. **Select:** Icon from phone menu.

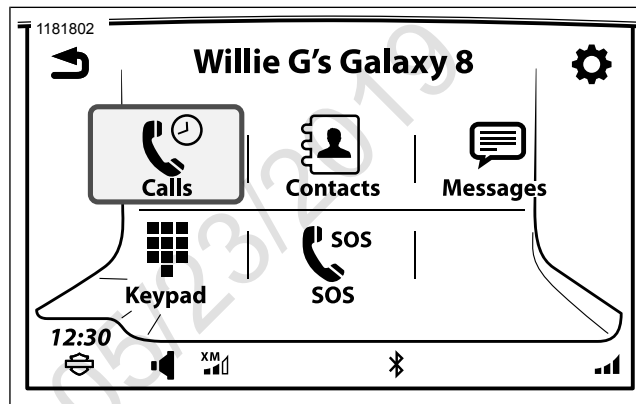

Figure 12. Phone Menu

Receiving a Call

Select: Accept or Ignore.

VOICE RECOGNITION

NOTE

A teleprompter is shown when the Voice Recognition switch is pressed. The teleprompter screen shows commonly used commands, along with a line item to display more commands.

1. See Figure 4. **Select:** Voice recognition.

2. When the system beeps, speak a voice command calmly and normally into the headset microphone.

NAVIGATION SYSTEM

Map Display

NOTE

See *Boom! Box* owner's manual for additional information.

1. **Navigate:** Home > Navigation.
2. See Figure 13. **Select:** Search or Menu icons. This is the starting points for seeking destinations.

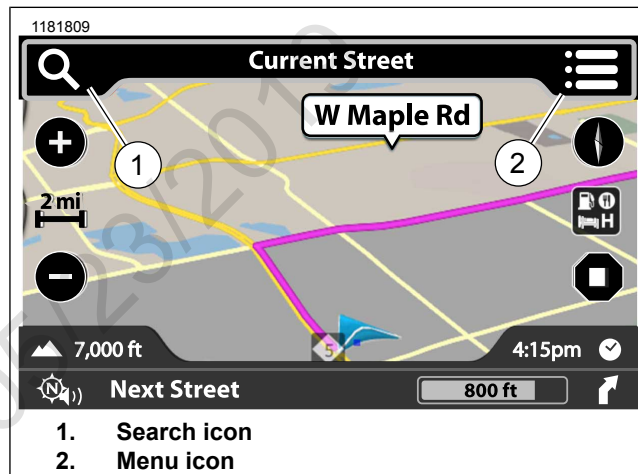

Figure 13. Map Display

Select From Category

1. **Navigate:** Home > Navigation.
2. **Select:** Search icon.
3. See Figure 14. **Select:** Category icon.

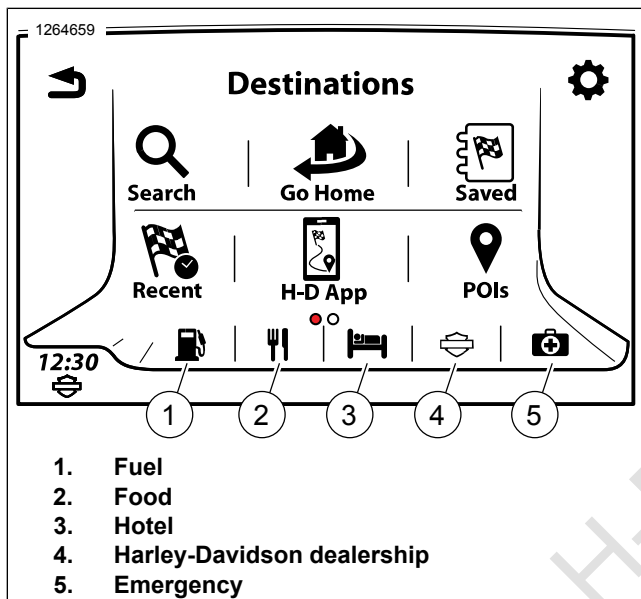

Figure 14. Categories

Input Address

1. **Navigate:** Home > Navigation.
2. **Select:** Search icon.

3. **Select:** Search.
4. See Figure 15. **Prompt:** Search: Near Me
 - a. Input address of location.

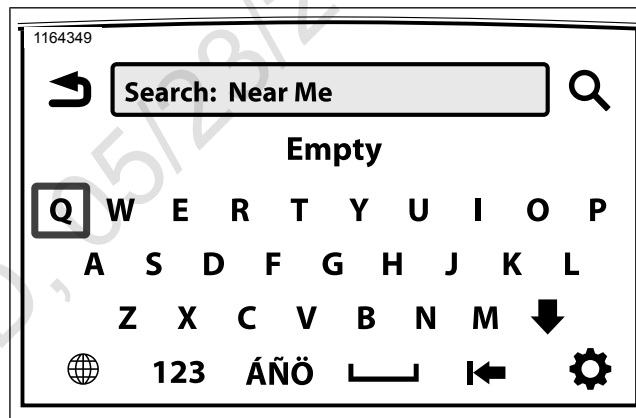

Figure 15. Input Address

Saving a Destination: Home

1. **Navigate:** Home > Navigation.
2. **Select:** Search icon.

3. **Select:** Go Home icon.
4. From **Set Home** screen, select a destination (perform a search, select a recent destination, select a POI or a Saved file).
5. **Select:** Save.
6. **Select:** As Home.

Route to Destination: Home

1. **Navigate:** Home > Navigation.
2. **Select:** Search icon.
3. **Select:** Go Home icon.

© 2019 H-D, 05/23/2019

NOTES

© 2019 H-D, 05/23/2019

ACRONYMS USED IN THIS MANUAL

See Table 5. explains the acronyms used throughout this manual.

Table 5. Acronyms

ACRONYM	DESCRIPTION
2D	Two Dimensional
3D	Three Dimensional
AVC	Automatic Volume Control
BT	Bluetooth
BTA	Bluetooth Audio
BTHS	Bluetooth Headset
CB	Citizens Band
COM	Communication
CVO	Custom Vehicle Operations
DISP	Display
EITMS	Engine Idle Temperature Management System
GPS	Global Positioning System
NAV	Navigation
NTFS	New Technology File System
POI	Point Of Interest
PTT	Push To Talk
RDS	Radio Data System
RBDS	Radio Broadcast Data System
TA	Traffic Announcement
TP	Traffic Program

Table 5. Acronyms

ACRONYM	DESCRIPTION
THD	Total Harmonic Distortion
TMC	Traffic Message Control
TPMS	Tire Pressure Monitoring System
USB	Universal Serial Bus
VOX	Voice operated transmission
WHIM	Wireless Headset Interface Module

DEFINITIONS USED IN THIS MANUAL

Breadcrumbs

Breadcrumbs are a navigational aide showing the string of selections made to locate a specific function. Each item to select is separated by a greater than symbol ">".

Example: **Navigate:** Home > Setup > Audio Settings > Volumes > Speaker Volumes.

Media Filters

See Figure 16. **Select:** Media filter icon. This will display categories associated with files connected via the USB port.

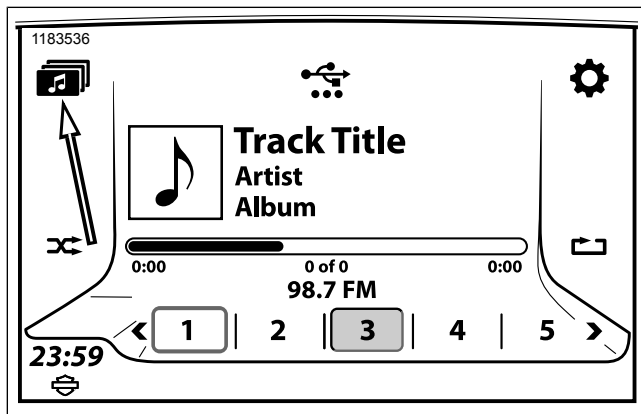

Figure 16. MEDIA Filters

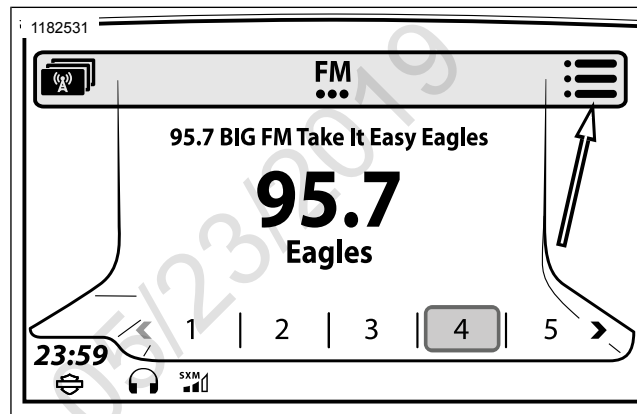

Figure 17. Menu Icon

Menu Icon

See Figure 17. **Select:** Menu icon. This opens a menu of additional options. Select the button again to return to the original screen.

Multi-page Indicator

See Figure 18. When a multi-page indicator is displayed, swipe left or right to view other screen choices.

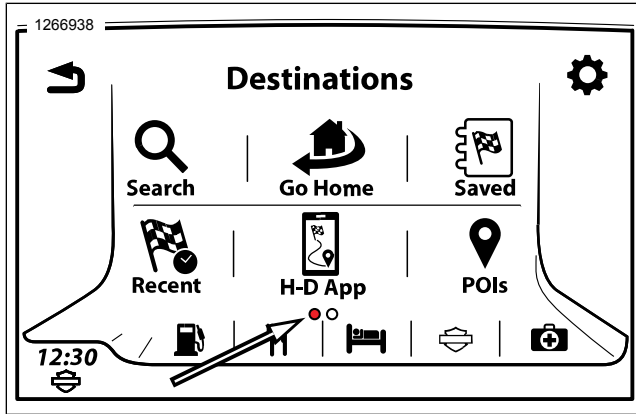

Figure 18. Multi-page Indicator

SiriusXM Categories Icon

See Figure 19. The SiriusXM (SXM) icon opens a categories list that is selectable by genre, artist or song.

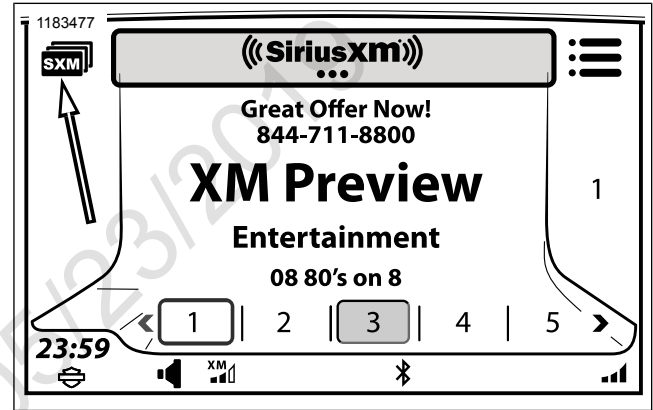

Figure 19. SiriusXM Categories Icon

Station Categories Icon

See Figure 20. The station categories icon accesses selectable categories allowing for customized scan function.

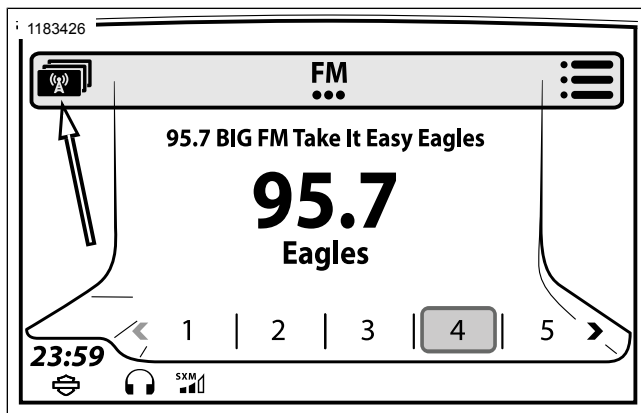

Figure 20. Station Categories Icon

SPECIFICATIONS

Not all features are available on all models, destinations or year of manufacture. Most screen illustrations in this manual show the GTS radio.

Vehicles are equipped from the factory with the radios and features as described in Table 6 and Table 7. Also see System Information (Page 70) to view the hardware, software and navigation database installed on your vehicle.

Table 6. Boom! Box Radio Identification

MODEL	IDENTIFYING FEATURES *
GTS	Screen measures 165 mm (6.5 in) diagonally. Radio face is glass and has four fixed-key buttons. Splash screen shows H-D bar & Shield logo.
GTS (CVO)	Screen measures 165 mm (6.5 in) diagonally. Radio face is glass and has four fixed-key buttons. Splash screen shows Custom Vehicles Operations logo.

Table 7. Infotainment System Features

FEATURES	GTS	GTS (CVO)
Tuner ¹	X	X
Media playback	X	X
Phone	X	X
Voice commands	X	X
Vehicle status	X	X
Wireless headset interface module (WHIM)		X
CB radio ²		X
Rider/passenger intercom ³	X	X
Weather alert ^{2,5}		X
Navigation ²	X	X

Table 7. Infotainment System Features

FEATURES	GTS	GTS (CVO)
SiriusXM radio and services ^{2,4}		X
¹ Frequency bands, DAB and RDS features depend on region. ² Not available in all regions. ³ Models with passenger headset. ⁴ Requires activation. ⁵ CB equipped only.		

Table 8. Display

ITEM	DESCRIPTION
Screen	Weatherproof WVGA TFT MVA-PSV color touchscreen
Languages	English (US), English (UK), Czech, Dutch, French (Canada), French (France), German, Italian, Japanese, Polish, Portuguese (Brazil), Portuguese (Portugal), Russian, Spanish (Mexico), Spanish (Spain), Turkish
Day/night color modes	Day, night or automatic sensor activated
Background colors	6 selectable colors

Table 8. Display

ITEM	DESCRIPTION
High contrast day colors	Selectable in day or automatic color modes
Adjustable brightness	Manual or automatic sensor activated

Table 9. Controls

ITEM	DESCRIPTION
Illuminated face-plate controls	Home, information, on/off/mute, audio settings, four fixed-key touchscreen buttons
Integrated handle-bar controls	Home/volume/seek/previous/next, voice recognition, CB push-to-talk (PTT)/squelch, cursor/select, back switches
Integrated passenger controls	Push-To-Talk (PTT)/Volume (VOL±), MODE/UP/DOWN switches
Keyboard	Full keyboard, full QWERTY keyboard with smart speller
Screen selection	Touchscreen

Table 10. Bluetooth

ITEM	DESCRIPTION
Functions	Media streaming, phone calls, phone book download, text message notifications
Protocols	Hands-Free Calling Profile (HFP, HFPAG/HFPHF services), Phone Book Access Profile (PBAP), A2DP/AVRCP (AV/Music, A2DP sink/source services), Message Access Profile (MAP), HFP+PBAP+AV Profile (simultaneously used), MP3, MPEG-4AAC, WMA, WAV
Paired devices	6 devices maximum
Connections	1 for phone, 1 for media
Range (approximate)	30 ft (9 m)

Table 11. Tuner

ITEM	DESCRIPTION
Tuner bands ¹	AM, FM, MW, LW, DAB+, CB, Satellite Radio and Weather Band (dependent on region).
Tuner presets	20 Satellite radio, 15 FM/DAB+, 5 AM, 5 LW, 5 MW, 5 Weather Band
Global presets	Up to 4 pages with up to 20 total
Tuning modes	Tune, seek, scan, preset scan
Favorites	6 presets

Table 11. Tuner

ITEM	DESCRIPTION
Category filtering (PTY)	Selectable
Stations list	Dependent on region
RDS/RDBS	Dependent on region
RDS functions	Traffic Announcement/Traffic Program, Alternate Frequency Switching, Regionalization (dependent on region)
Single/dual tuner	Dependent on region
Weather band channels	7 channels, 5 presets
Weather alert	Select regions, requires CB module
Weather band frequency	WB1-162.400MHz, WB2-162.425MHz, WB3-162.450MHz, WB4-162.475MHz, WB5-162.500MHz, WB6-162.525MHz, WB7-162.550MHz
Clock	GPS/RDS/user-selectable time setting, automatic time zone adjustment

¹ Frequency bands and RDS features depend on region.
² Not available in all regions.
³ Models with passenger headset.
⁴ Requires activation.
⁵ CB equipped only.

Table 12. Media

ITEM	DESCRIPTION
Media presets	20 per device
Media devices supported	USB flash drives, Apple devices (iAP2, iUI), PlaysForSure devices, SDRAM card with reader
USB device compatibility	exFAT, FAT32, NTFS, HFS+ (exFAT format required for data import/export and software updates)
Media file playback (USB/PlaysForSure)	MP3, MP4, MPEG-4AAC, M4A, M4B, WAV, WMA
Media file playback (Bluetooth)	MP3, MPEG-4AAC, WMA, WAV
Media file playback (Apple devices)	All iPod supported file types decoded and played from Apple device
USB port	USB 2.0, 5 V, 1.0 A charging current
Media controls	Repeat, shuffle, find, Bluetooth streaming, pause/resume
Playlists supported (Apple)	All playlists native to Apple iPod
Playlists supported (USB/PlaysForSure)	ASX, WPL, M3U, PLS, XML, RMP

Table 13. Audio

ITEM	DESCRIPTION
Speed volume	4 levels of automatic gain based on speed, plus off setting
Audio routing	Adjustable speaker/headset audio routing (tuner, communication device, phone)
Sound adjustment	Audio tone and fade adjustment
Headset connectors	7-pin DIN with protective cap (number of headset ports depends on vehicle configuration)
Headsets (wired)	Helmet-mounted 7-pin DIN headset with microphone boom (non-mounted headset optional)
Headsets (wireless)	Boom Audio 20S EVO Bluetooth helmet headset with microphone (CVO)
Squelch	15 step adjustable, plus full on/off
Output	25 W (GTS) or 75 W (GTS CVO) per channel
Speaker configurations	2 sealed and closed front speaker housings, 2 bass port rear speakers (models with Tour-Pak), 2 saddlebag speakers (FLHXSE and FLTRXSE). 2 fairing lower speakers (FLHXSE).
Speakers, fairing: Touring and Trike	6.5 in, 1.7 ohm, 88.9 dB, 75-16.2kHz, 51 W
Speakers, Tour-Pak: Touring and Trike	6.5 in, 1.7 ohm, 88.9 dB, 75Hz-16.2kHz, 51 W

Table 13. Audio

ITEM	DESCRIPTION
Speakers, fairing: FLHTKSE	6.5 in, 1.7 ohm, 91.5 dB, 75Hz-20kHz, 75 W
Speakers, fairing lower: FLHTKSE	6.5 in, 2.0 ohm, 91.5 dB, 75Hz-20kHz, 75 W
Speakers, Tour-Pak: FLHTKSE	6.5 in, 1.7 ohm, 91.5 dB, 75Hz-20kHz, 51 W
Speakers, fairing: FLHXSE	6.5 in, 1.7 ohm, 91.5 dB, 65Hz-20kHz, 150 W
Speakers, saddle- bag: FLHXSE	5 x 7 in, 1.7 ohm, 91 dB, 60Hz-20kHz, 150 W
Amplifiers - Watts per channel	Internal 25 W amplifier (all models, turned off for CVO), 75 W fairing amp- lifier (CVO), additional 75 W amplifier in left saddlebag (FLHXSE and FLTRXSE), third 75W amplifier in RH saddlebag (FLHXSE)
Distortion	<1.5% THD+N

Table 14. Phone

ITEM	DESCRIPTION
Features	Inbound/outbound calls, call history, mute/unmute, phone book download, emergency phone calling, point of in- terest dialing
Call history	Up to 60 calls (20 received, 20 missed, and 20 dialed calls)
Saved phone num- bers	Up to 200 contacts or phone numbers
Compatible phones	See www.H-D.com for phone list
Calls supported	Only one call at a time. Call waiting and three-way calling not supported
Connections	USB (media and charging only), Bluetooth (calls, text messaging, streaming media)
Text messaging	Inbound SMS messages (with text-to- speech), outbound text message autoreply (not available on all devices)
Indicators	Signal strength and battery level indicat- ors, low battery indicator, text message notification
Ring tones	4 built-in ring tones, 1 custom ring tone (media file import)

Table 15. Wireless Headset Interface Module (WHIM)

ITEM	DESCRIPTION
Key specifications	Bluetooth 4.1; Supporting profiles: Headset Profile, Hands-Free Profile (HFP), Advanced Audio Distribution Profile (A2DP), and Audio Video Remote Control Profile (AVRCP)
Firmware	Upgradeable
Bluetooth	Dual module communication system, intercom up to 2.0 kilometers (1.2 miles)*, audio recording, pairing for dual mobile phones, hands-free for Bluetooth mobile phones, stereo headset for Bluetooth audio devices such as MP3 players, stereo headset for Bluetooth GPS navigations
Reset to factory settings	Yes
Fault reset	Yes
Certification and safety approvals	FCC, FCC, CE, IC, RoHS, WEEE

Table 15. Wireless Headset Interface Module (WHIM)

ITEM	DESCRIPTION
Features	Bluetooth 4.1, music sharing, playback control, versatile jog control, speed dial, audio booster, use while charging, individual volume control, dual Bluetooth module communication system, audio multitasking, multi-way intercom up to 4 connections, group intercom, Bluetooth intercom up to 2.0 kilometers (1.2 miles)*, smartphone app for iPhone and Android, universal intercom, advanced noise control, Intuitive voice prompts and voice commands, Bluetooth audio recording, all-in-one helmet clamp kit, built-in FM radio tuner with a station scan and save function, Bluetooth pairing for dual mobile phones, Bluetooth hands-free for Bluetooth mobile phones, Bluetooth stereo headset for Bluetooth audio devices such as MP3 players, Bluetooth stereo headset for Bluetooth GPS navigations
*In open terrain	

Table 16. CB Radio: Bike-To-Bike Communications

ITEM	DESCRIPTION
CB channels	40
Frequency range	26.925 to 27.405 MHz
Transmitter output	4 W
Modulation	AM or FM (depending on region)
Squelch	15 step adjustable, plus full on/off

Table 17. Intercom

ITEM	DESCRIPTION
Communication	Rider/passenger headset communication
Operation	Push-to-talk (PTT) or voice activation (VOX)
Adjustments	VOX sensitivity, automatic speed sensitivity adjustment

Table 18. Voice Recognition

ITEM	DESCRIPTION
Functions	Tuner, media, phone, SiriusXM, navigation, Siri
Languages (one-shot destination entry)	<ul style="list-style-type: none"> English (US), French (CA), Spanish (MX) (for North America 49ST/CAL/CAN configurations). English (US/UK), French (FR/CA), Spanish (MX/ES), Czech, Dutch, German, Italian, Japanese, Polish, Portuguese (BR/PT) Russian, Turkish (for ENG/HDI-Europe configurations). Not supported for other destinations.
Languages (other commands)	English (US/UK), French (FR/CA), Spanish (MX/ES), Czech, Dutch, German, Italian, Japanese, Polish, Portuguese (BR/PT) Russian, Turkish (for ENG/HDI-Europe configurations).

Table 19. SiriusXM

ITEM	DESCRIPTION
Subscription	Free 3-month trial subscription for GTS CVO, optional module and subscription required for GTS systems
Channels	Over 200 channels

Table 19. SiriusXM

ITEM	DESCRIPTION
Radio features	Channel list, direct tune, scanning, song/artist tagging, program categories
Specialty services	Game Zone, fuel prices, weather, traffic
Game Zone	Game and score alerts, up to seven teams
Fuel prices	Up to 30 nearest stations within 100 miles, sort by price/distance/brand, navigate/call station
Weather forecast	Current, daily (3 hour and 6 hour), and 5-day forecast
Weather map	Radar, weather fronts, atmospheric pressure
Traffic	Traffic navigation mapping, rerouting, traffic alerts

Table 20. Navigation

ITEM	DESCRIPTION
Map display	Two data fields, next turn guidance, current street, POI icons, navigation routing, traffic flow/events (requires RDS or SiriusXM traffic service), 3D terrain and landmarks (6.5 CVO only)
Map orientation	North up, 2D heading up, 3D heading up
Points of interest (POIs)	Over 80 POI types

Table 20. Navigation

ITEM	DESCRIPTION
Navigation route selection	Address, recent destination, home destination, phone book contact, POI, dealership, emergency facility, coordinates
Rides	Depends on complexity and length of the Rides. Limit is the GTS radio's memory capacity.
Waypoints per ride	Up to 400 destinations per ride
Trails	Up to 20 trails
File export	GPS Exchange Format (GPX) export of Rides, Trails and saved Destinations
File import	GPX and V-card contact files (VCF)
Maneuvers (turn-by-turn instructions)	Next turn, list of turns, view turn location, avoid turns and roads
Lane guidance	Lane guidance arrows, signpost and junction view
Saving destinations	Current location, preferred POI, home location
Traffic (requires RDS or SiriusXM Traffic)	Traffic flow (green/yellow/red), traffic event icons, traffic event list, rerouting
GPS coordinates	Current location or route guidance to coordinates
Touchscreen selection	On screen scrolling and destination selection
Avoidances	Selectable
Detours	Automatic or manually selectable

Table 20. Navigation

ITEM	DESCRIPTION
Compass	Full screen compass and directional heading markers
Voice prompts	Selectable (on/off), adjustable volume
Other features	Round trip guidance, trip summary, phone contact navigation, route simulation, low fuel navigation alert, graphical signpost display
Map database	North American map (for North America 49ST/CAL/CAN configurations). European map (for ENG/HDI-Europe configurations). Map optional (other destinations).

Table 21. Vehicle Status

ITEM	DESCRIPTION
TPMS	Tire pressure monitoring system (CVO only)
Ride Summary	Average speed/MPG, distance traveled, fuel used/stops, destination arrival date, time spent traveling, destination start date

Table 21. Vehicle Status

ITEM	DESCRIPTION
Info	Departure time/estimated arrival time/distance,current speed, actual time/actual distance, distance until next turn, air temperature, altitude
Engine/Fuel Info	Oil pressure, distance to empty, distance since last service, Engine Idle Temperature Management System (EITMS)

TOUCHSCREEN

See Figure 21. Press on touchscreen to select menu items and operate the radio. The touchscreen can be operated while wearing riding gloves.

The screen is designed to minimize glare, be viewable in all lighting conditions and be operable in wet weather conditions.

To properly care for the radio faceplate and touchscreen, see Audio System Care (Page 117).

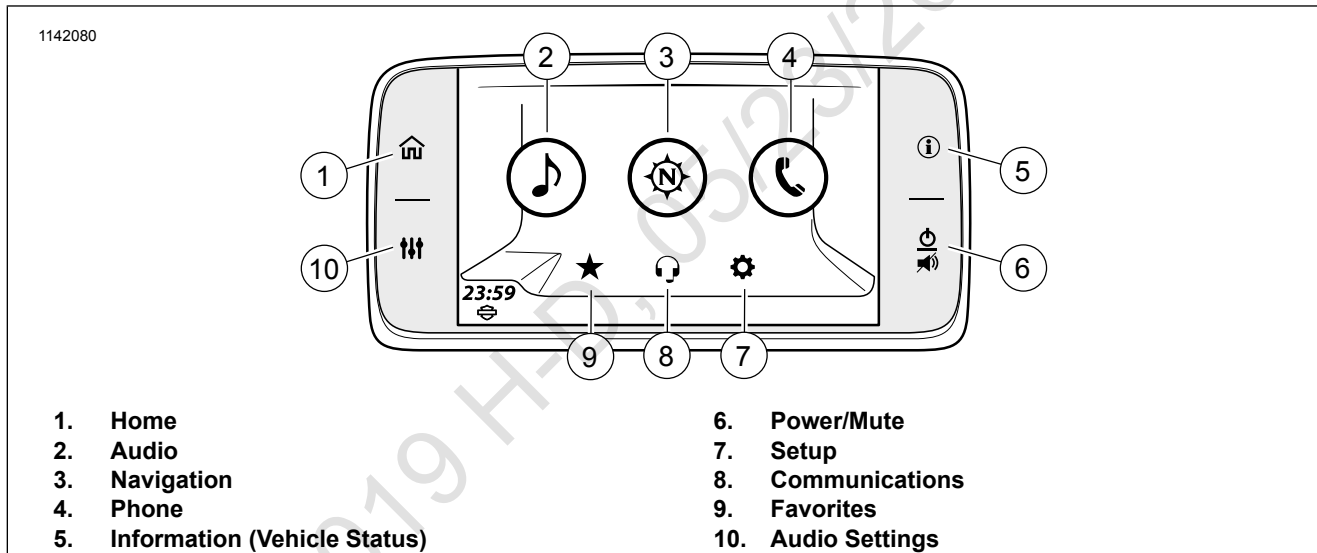

Figure 21. Faceplate Home Screen Selections

Home

Select **Home** to display the Home screen. Press Home again to show the current audio source (tuner station, media file, or phone screen).

Audio

Select **Audio** to display the audio sources (tuner station, media file or phone).

Tuner (NA): AM, FM, WB (weather band)

Tuner (EU): MW, LW, FM, DAB+

Media: iPod, USB Media, Bluetooth Audio, Phone, SiriusXM (if applicable)

Navigation

Select **Navigation** to display the map. The current location will be shown at the top of the map screen and selecting the search icon will be able to do some of the following:

- Setting Go Home address
- Perform a search, input a destination or selecting a POI
- Selecting from a list of preset destinations: Gas, Food, Hotel, H-D Dealers, Emergency

Compass: For radios without navigation, press the **Navigation** icon to display the compass. See Navigation (Page 137) to configure and operate the navigation features.

Phone

Select **Phone** to display available phone lists and dialing choices.

Calls: Displays the call activity list for the current phone. The list can be filtered to show all, missed, received or dialed.

Contacts: Choose from contacts on radio, contacts on phone or sync phone contacts.

Message: Text message from paired phone.

Keypad: Used to manually enter a phone number.

SOS: Emergency number stored in radio.

Information (Vehicle Status)

Press **Vehicle Information** to display various vehicle information. Press the button again to cycle the Vehicle Status screen.

Power/Mute

When turning the motorcycle on, the radio resumes its previous state (radio on or off).

Power On: With the motorcycle turned on or in accessory mode, press POWER/MUTE to turn on the system. The system returns to the last state as when it was last turned off (media file, station, and so on).

Power Off: Press and hold POWER/MUTE for three seconds to turn the system off. The screen goes black and the clock is displayed. The radio remains in sleep mode and continues to draw current while the motorcycle is turned on or in accessory mode. The radio does not reinitialize unless the vehicle is turned off for up to 30 seconds.

Mute/Pause: Briefly press POWER/MUTE to mute audio. Radio stations, CB, intercom, navigation audio and prompts are muted. Media devices are paused.

Unmute/Resume: To resume audio or media files, briefly press POWER/MUTE again.

NOTE

- *Audio can also be unmuted by pressing the volume switch on the left hand control.*
- *Media can also be resumed by pressing the PREVIOUS/NEXT switch on the left hand control.*
- *POWER/MUTE does not mute phone call audio. Use the Mute function in the phone menu to mute inbound/outbound phone audio during a call.*

Setup

Configure the system settings before riding the motorcycle, with the motorcycle stationary and set to accessory mode. Adjust the options to match your personal riding style, and to make best use of any features or devices that you may be using. If there are problems with any features in the radio, first check the relevant settings.

Most settings are similar for all radios. However, some features or selections may be unique or unavailable on some vehicles. Some settings may also be specific for particular countries or regions. See Specifications (Page 24) for more information about the features available on your motorcycle and in your region.

If audio accessories have been added to the motorcycle, see the instruction sheets for proper configuration and operation of those accessories.

Communications

The intercom allows the rider and passenger to talk with each other through the headsets. The intercom can be operated by pressing the PTT switch or by using voice operated transmission (VOX). When voice input is picked up by the rider or passenger microphone, the intercom is automatically activated. This process is known as "breaking VOX".

The rider or passenger can initiate intercom communication. When the intercom is active, tuner and media volume are automatically reduced so the intercom can be heard through the headsets.

For privacy, the intercom is only heard through the rider and passenger headsets. It is not heard through the speakers.

Microphone sensitivity and headset volume can be adjusted. The microphone sensitivity (VOX) applies to both rider and passenger microphones. The rider and passenger headset volumes are adjusted independently.

NOTE

Some local governments prohibit or restrict the use of headset (helmet-mounted) speakers. Check with local authorities and obey all applicable laws and regulations.

Favorites

Selecting the favorites icon displays up to six saved favorites.

1. **Navigate:** Home > Favorites.
2. Press and hold desired preset until screen title changes to **Select a Favorite Type**.

NOTE

To overwrite a currently stored favorite, repeat the procedure for setting.

3. **Select:** Type.
 - a. **Tuner:** Currently playing station, SXM, AM, FM or WB.
 - b. **Phone:** Recent, Contacts on Radio or Contacts on Phone. Select from list.
 - c. **Location:** Recent or Saved. Select from list.
 - d. **Media:** usb. Select from list.
4. **Listen to favorite:** Briefly press the favorites icon. Select from list.

Audio Settings

The audio settings are used to custom tune the radio output.

Bass: Adjust audio bass from minimum to maximum.

Treble: Adjust audio treble from minimum to maximum.

Audio Routing: Direct audio through speakers or headset.

Fade: Adjust center of audio output.

Volumes: Adjust speaker, rider headset and passenger headset volumes. Also, turn speed volume on or off.

LEFT HAND CONTROL

Some features and functions shown are model and/or region-specific.

See vehicle owner's manual for functionality of other hand control switches.

See Figure 22. The **Home/Volume/Previous/Next** five-way switch operates radio features on equipped vehicles.

Home: Press to display the Home screen. Press again to display current audio source (tuner station, media file, or phone screen).

Previous/Next: Tap left or right to select previous/next radio frequency or media file.

NOTE

- A one second press will seek the next transmitting station.
- A long press will accelerate through frequencies, or fast forward/rewind through media files.

Volume: Press up to increase volume or down to decrease volume to speakers or rider headset. Volume control can also unmute audio and resume media.

NOTE

- Unlike the **Mute** switch, decreasing volume to zero does not pause media.
- Volume output is also affected by the speed volume setting. See *Speed Volume (Page 67)*.
- CB, intercom, phone calls and system prompts have independent volume levels. Adjust volume for these different audio sources while they are active. See appropriate sections for each of these functions for operation.

Voice Recognition: This switch activates voice recognition features on equipped vehicles. With a headset connected, press **Voice Recognition** switch. The radio beeps and shows a list of available commands. Speak desired command into headset microphone. See *Voice Recognition (Page 179)*.

To cancel voice recognition, press and hold **Voice Recognition** switch for three seconds, or press **Home** hand control switch.

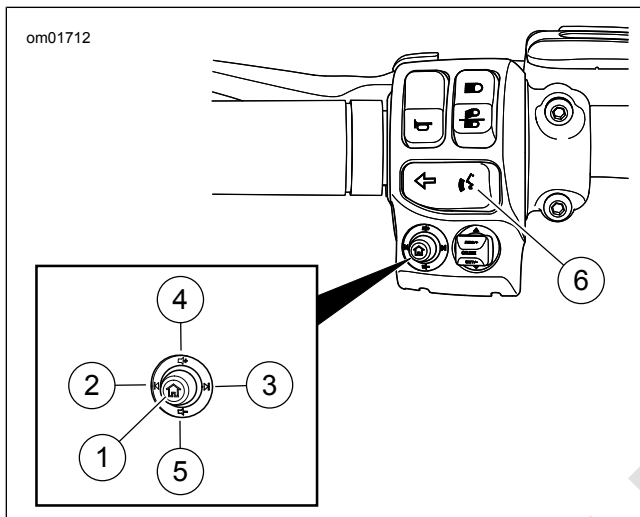

Figure 22. Left Hand Control Audio Functions (typical)

Table 22. Left Hand Control Audio Functions

ITEM	ICON	NAME	FUNCTION
1		Home	Short Press: Toggles between current screen and Home screen. Long Press: Toggles the Quick Jump screen.
2		Previous /Seek Down	Media: Previous media file. Tuner: Tune/seek down.

Table 22. Left Hand Control Audio Functions

ITEM	ICON	NAME	FUNCTION
3		Next/Seek Up	Media: Next media file. Tuner: Tune/seek up.
4		Volume Up	Increases volume.
5		Volume down	Decreases volume.
6		Voice Recognition	Initiates a voice recognition session. Also, a long press initiates Siri for Bluetooth paired iPhone or Apple CarPlay when a headset is connected.

Quick Jump: On left hand control do a long press on the **Home** switch and this will display the **Quick Jump** screen. Use the left or right hand control switch to make selection. See Figure 23.

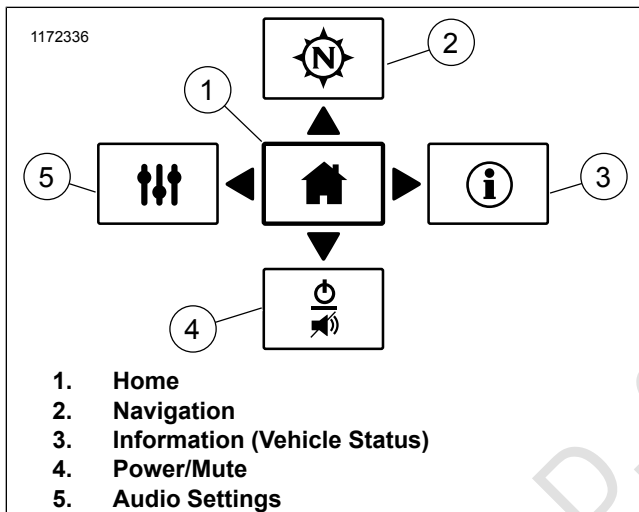

Figure 23. Quick Jump

RIGHT HAND CONTROL

Some features and functions shown are model and/or region-specific.

See vehicle owner's manual for functionality of other hand control switches.

See Figure 24. **Back:** Press to view previous screen on radio.

NOTE

- A long press will change the screen between normal day and high contrast color.

Push-To-Talk/Squelch (PTT): Press to transmit over CB or intercom. Both rider and passenger microphones are live. Intercom can also be operated by voice activation (VOX).

Squelch (SQ+/SQ-): Raise squelch (SQ+) to prevent noise or unwanted weak signals from unmuting the CB. Lower squelch (SQ-) to a level that allows desired CB signals to unmute the CB.

Cursor/Select: The **Cursor/Select** five-way switch can be used to select items on the radio screen.

Cursor: Press switch in desired direction to move highlighted cursor to another selection on radio screen.

Select: Press switch straight in to select a highlighted item or toggle a feature on radio screen.

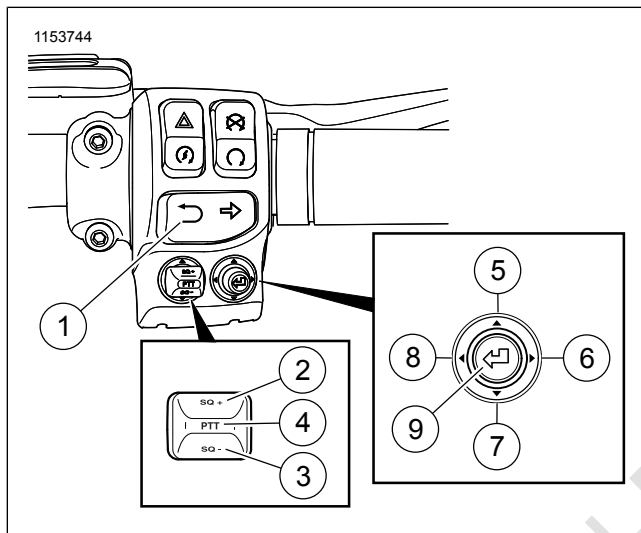

Figure 24. Right Hand Control Audio Functions

Table 23. Right Hand Control Audio Functions

ITEM	ICON	NAME	FUNCTION
1		Back	Short Press: Back to previous screen. Long Press: Screen transitions between normal day color and high contrast color.
2	SQ +	CB Squelch +	Increases CB squelch level (if equipped).
3	SQ -	CB Squelch -	Decreases CB squelch level (if equipped).
4	PTT	CB Push to Talk	Press and hold to transmit on CB/intercom (if equipped).
5		Cursor Up	Moves the highlighting up through the selections.
6		Cursor Right	Moves the highlighting right through the selections. Tuner: Next preset up.
7		Cursor Down	Moves the highlighting down through the selections.
8		Cursor Left	Moves the highlighting left through the selections. Tuner: Next preset down.
9		Select /Enter	Selects highlighted item.

REAR (PASSENGER) CONTROLS

See Figure 25. Some vehicles have passenger controls on the right side of the Tour-Pak. These controls allow the passenger to operate functions in the radio.

MODE/UP/DN Switch

MODE: Press switch straight in to select the next available audio source.

UP/DN: Press switch up/down to select the previous/next radio station or media file.

Push-To-Talk (PTT)/Volume (VOL) Switch

PTT: Press switch to transmit over CB or intercom.

VOL+/VOL-: Press switch up (or down) to raise (or lower) the volume to the passenger headset. This switch does not affect the rider headset volume or speaker volume.

Enabling Rear Controls

The PTT/VOL switch is always enabled. However, the MODE/UP/DN switch can be enabled or disabled through the setup screens. See Rear Controls (Page 68) to enable these rear controls.

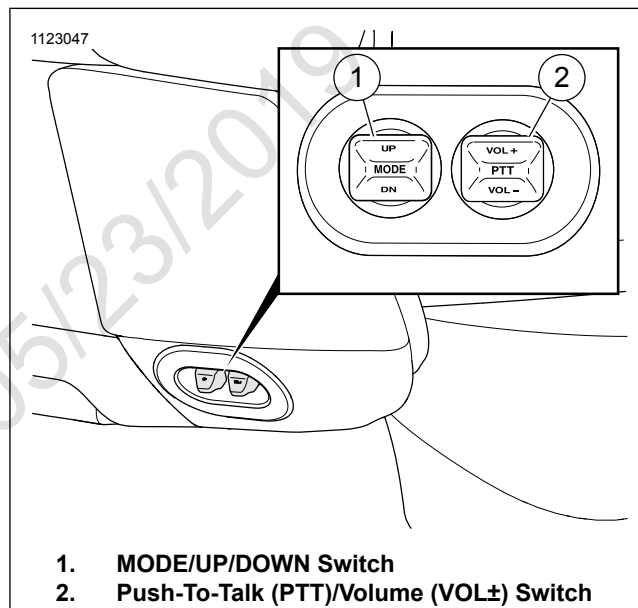

Figure 25. Passenger Controls

Table 24. Rear (Passenger) Control Audio Functions

ITEM	ICON	NAME	FUNCTION
1	MODE	Mode	Cycles to next available audio source.
	UP	Next/Seek Up	Tuner: Seek up. Media: Next file.
	DN	Previous /Seek Down	Tuner: Seek down. Media: Previous file.
2	PTT	CB Push-to-Talk	If Equipped: Press and hold to transmit on CB/intercom.
	VOL+	Volume Up	Increases volume.
	VOL-	Volume Down	Decreases volume.

HEADSET CONNECTION

▲ WARNING

Do not select a volume level that blocks out traffic noise or interrupts the concentration necessary for safe operation of the motorcycle. Distractions or a volume level that blocks out traffic noise could cause loss of control resulting in death or serious injury. (00539b)

NOTICE

Do not pull on the cord to remove the headset from the socket. Pull on the headset jack to disconnect the headset from the socket. (00174a)

See Figure 26 and Figure 27. Some vehicles have a rider headset connector on the fuel tank panel and a passenger headset connector on the left speaker pod. The headsets are used to operate the CB, intercom, voice recognition commands and other features on equipped models.

Use the Harley-Davidson 7-pin DIN headset that is supplied with equipped models or purchased from a Harley-Davidson dealer. Other headset microphones are not compatible. See the instructions that are included with the headset to install in a helmet. Connect the headset by aligning the ridge on the headset with the slot on the connector as shown in Figure 26. The headset only works if the connector is properly installed.

When using headsets, set the volume to a level where traffic and sounds from the surrounding environment can still be heard.

The socket caps remain shut when not in use to prevent dirt and water from entering the socket. Close both socket caps before washing the motorcycle.

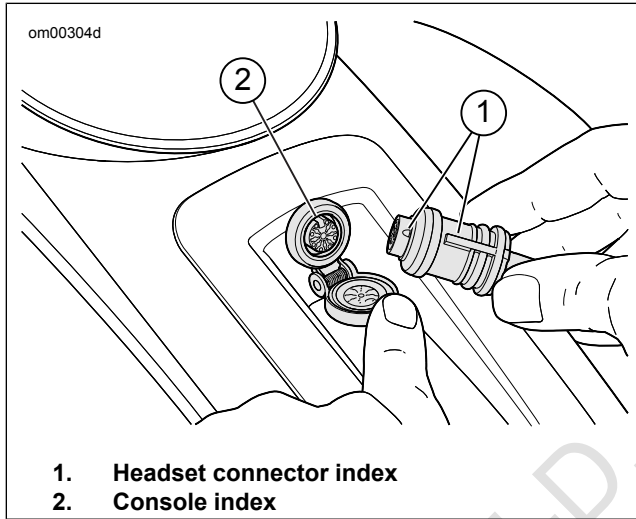

Figure 26. Rider Headset Connector (typical)

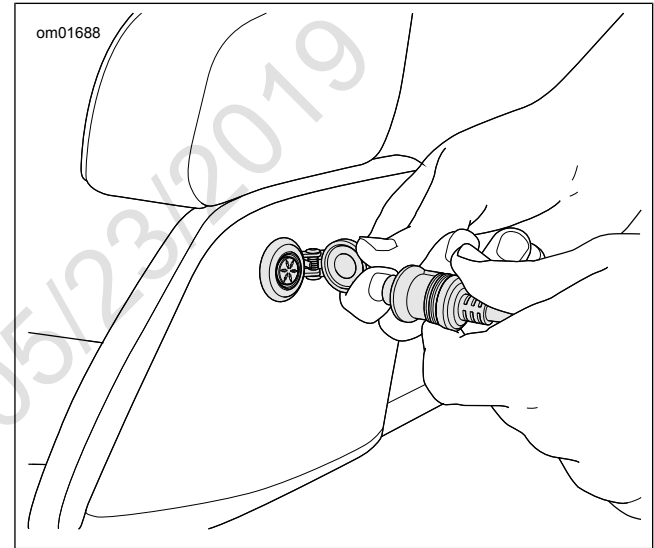

Figure 27. Passenger Headset Connector

Microphone Positioning

NOTE

Poor or improper microphone placement may result in VOX setting issues.

Full face helmets: See Figure 28. Route the boom below the helmet, with the microphone oriented upright inside the helmet, so the boom does not touch the chin.

Open face or half helmets: See Figure 28 and Figure 29. Position the microphone lightly touching or directly to the left of the mouth.

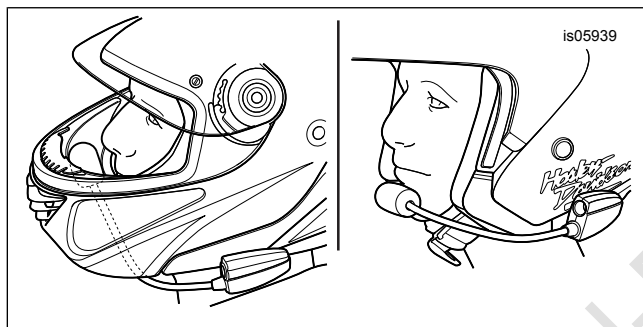

Figure 28. Microphone Positioning

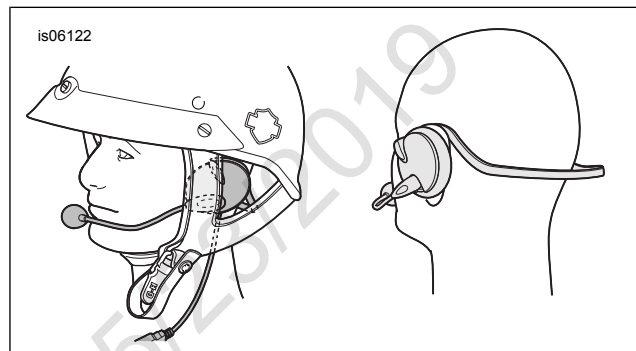

Figure 29. Headset and Microphone Positioning

MEDIA COMPARTMENT: USB PORT

See Figure 30 and Figure 31. The media compartment has a USB port to connect with a phone, media device or USB drive. An interface cable may be needed to connect with devices. The USB port is powered and operational when the vehicle is turned on or in accessory mode. Connected devices may be used for the following purposes.

Phone: Charges the phone and plays media files from the phone. However, phone calling and text messaging features are achieved only through Bluetooth connection.

Media device: Charges the device and plays media files.

USB drive: Plays media files, imports/exports navigation files, loads software updates, and imports ring tones.

Memory card: Some types of memory cards can be connected to play media files. Connection requires an adapter or reader.

H-D App (DOM only): Enables Rides and Points of Interest (POIs) to be transferred from the phone to the radio navigation system. USB cable is iOS only. Bluetooth works for both iOS and Android.

NOTE

Do not use media players with hard drives. Vibration may cause internal damage.

Devices can be added or removed while the radio is on. However, when importing/exporting files or installing updates to the radio, do not disconnect the USB device until the task has completed.

Keep the compartment door closed while riding to prevent items from falling out. Remove valuable items from the media compartment before leaving the vehicle unattended.

Media Compartment: Fixed Fairing Vehicles

See Figure 30. Fixed fairing vehicles have a media compartment in the right side of the fairing.

Open: Pull up on the front of the compartment door to open as shown.

Cleaning: The rubber or fabric insert in the compartment is attached with hook and loop fastening tape and can be removed for cleaning.

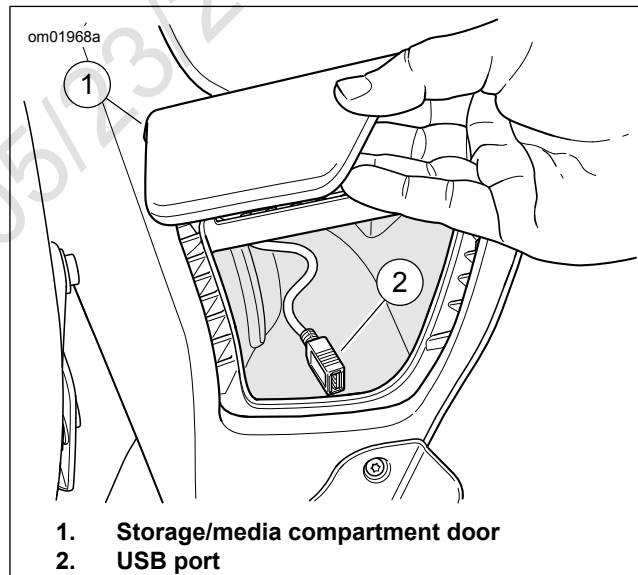

Figure 30. Storage/Media Compartment: Fixed Fairing Models

Media Compartment: Fork Mounted Fairing Vehicles

See Figure 31. Fork mounted fairing vehicles have a media compartment on the right side of the radio as shown. Insert the phone or media device into the foam cradle to secure the device and isolate it from vibration.

Open: Push lower portion of door and release to open.

Close: Firmly push the door shut until the latch engages.

Reset door latch: If compartment door was forced open or is not latching properly, the door latch may need to be reset. Push the door shut. Open the door. Close the door again to engage the latch mechanism.

Cleaning: The cradle can be removed for cleaning or to assist with installing or removing a device from the compartment.

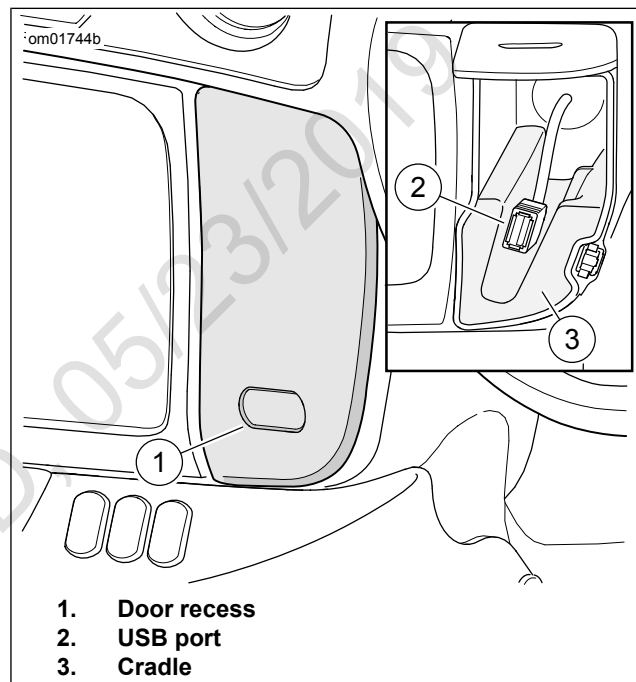

Figure 31. Media Compartment

SPEAKERS

The speaker types and arrangements are different across models. All speakers are weatherproof and sealed for use in

all riding weather conditions. See Audio System Care (Page 117) to properly care for speakers. See www.h-d.com store for available speaker options.

Fairing Speakers

Front speakers are designed into a ported enclosure in the fairing for additional bass response and higher fidelity. Models include different speaker specifications and arrangements within the inner fairing.

Fairing Lower Speakers

Fairing lower speakers are equipped on some models to provide more volume for the sound system. These are also available as accessories for vehicles with air-cooled engines.

Saddlebag Speakers

Saddlebag speakers are equipped on some models to provide additional surrounding volume for the sound system. These speakers use the saddlebag enclosure to provide enhanced bass response. A small amount of water may occasionally collect in the speaker cavities while parked outdoors. The saddlebag speakers are weatherproof, and the heat from speaker operation would soon evaporate the water, but there could be a temporary effect on sound quality. To promptly empty the speaker cavities, lift the saddlebag lids. Saddlebag speakers are also available as accessories.

Tour-Pak Speakers

These forward-facing speakers direct sound to the rider and passenger. The bass boost ports use the enclosed space in the Tour-Pak to provide an enhanced bass response with reduced distortion. The bass response of these ports may be affected when items are stored in the Tour-Pak or when the Tour-Pak lid is open.

AMPLIFIER

Some vehicles include an additional amplifier to drive greater sound output to the speakers. Boom! audio amplifiers bypass the internal amplifier in the radio to provide increased volume, reduced clipping, lower Total Harmonic Distortion (THD), optimized equalization and a fuller sound that cuts through wind and road noise. The amplifier is also available as an accessory.

Additional amplifiers may be needed when adding speakers to a vehicle.

ANTENNAS AND RECEPTION

NOTICE

Operating the CB radio without an antenna or with a broken antenna cable can result in damage to the transmitter circuitry. (00176a)

Tuner and CB antennas: See Figure 32. Antennas on the rear of the vehicle may be removed during vehicle storage. Make sure to install antennas before operating the radio. To install, hand tighten the antennas to the mounts. Antennas for the tuner and CB are different. For vehicles with a CB, always install the CB antenna (marked with the letters "CB" at the base of the mast) on the right side of the motorcycle. The antenna marked "AM/FM" is for tuner reception. Installing the incorrect antenna for the tuner or CB will result in degraded reception.

Hidden tuner antenna: Some vehicles have an antenna installed in the fairing for tuner reception (AM/FM/WB).

Satellite antennas: SiriusXM and GPS antennas are mounted within the fairing on equipped models. These antennas require no maintenance. SiriusXM satellite radio and GPS reception may be weaker when the vehicle is indoors.

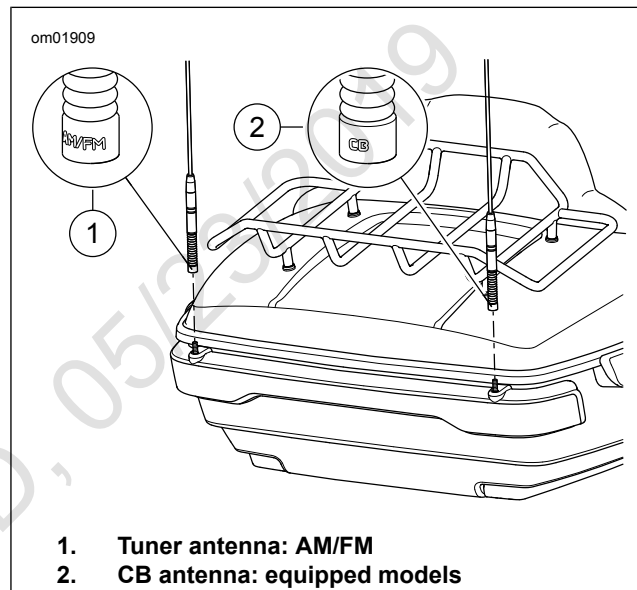

Figure 32. Antennas

BLUETOOTH

The system has Bluetooth capability for accessing media files and phone operation. See the Bluetooth (Page 112) section to set up and connect devices.

TURNING MOTORCYCLE ON, OFF OR TO ACCESSORY MODE

Turning on motorcycle: When the motorcycle is turned on, the radio returns to its previous state before shutdown. Features such as CB, intercom, current station or media playing resume as before the vehicle was turned off. A Bluetooth connection to the phone will attempt to resume.

Starting the engine: When starting the engine, the audio mutes and the screen turns off momentarily.

Radio on/off: If the radio is turned off before the vehicle is shutdown, it will remain turned off when the vehicle is turned back on.

Restart radio: To reinitialize the radio, allow the vehicle to remain turned off for up to 30 seconds before turning the vehicle back on.

Accessory mode: When the vehicle is in accessory mode, operation of the radio will result in some battery drain. The motorcycle will automatically turn off after two hours in accessory mode. Keyed vehicles enter/exit accessory mode by turning the ignition switch to the appropriate position. Keyless vehicles enter/exit accessory mode by holding the trigger switch on left control module.

Turning off motorcycle: If turning off the motorcycle while in an active phone call, the radio will prompt to transfer the

call back to the phone. If the prompt is not accepted, the radio will continue to support the call for approximately five minutes before automatically transferring the call back to the phone and shutting down. See Resuming Calls After Vehicle Shutdown (Page 132).

DISCONNECTING THE VEHICLE BATTERY

The system retains user data and system settings when the vehicle battery has been disconnected or main fuse is removed. Features such as navigation routes, paired devices, phone books, favorites, presets and system settings are retained in memory. The radio returns to its previous functionality after the battery is reconnected to the vehicle.

NOTES

© 2019 H-D, 05/23/2019

HOME SCREEN

See Figure 33. The Home screen provides access to all the features available for the system. The layout of items on this screen may be different depending on radio type and installed features.

According to the radio type, use the touchscreen or Cursor/Select hand control switch to make selections and operate the system.

During initialization and startup, some features may be unavailable for a short time (such as navigation, SiriusXM, media and voice recognition).

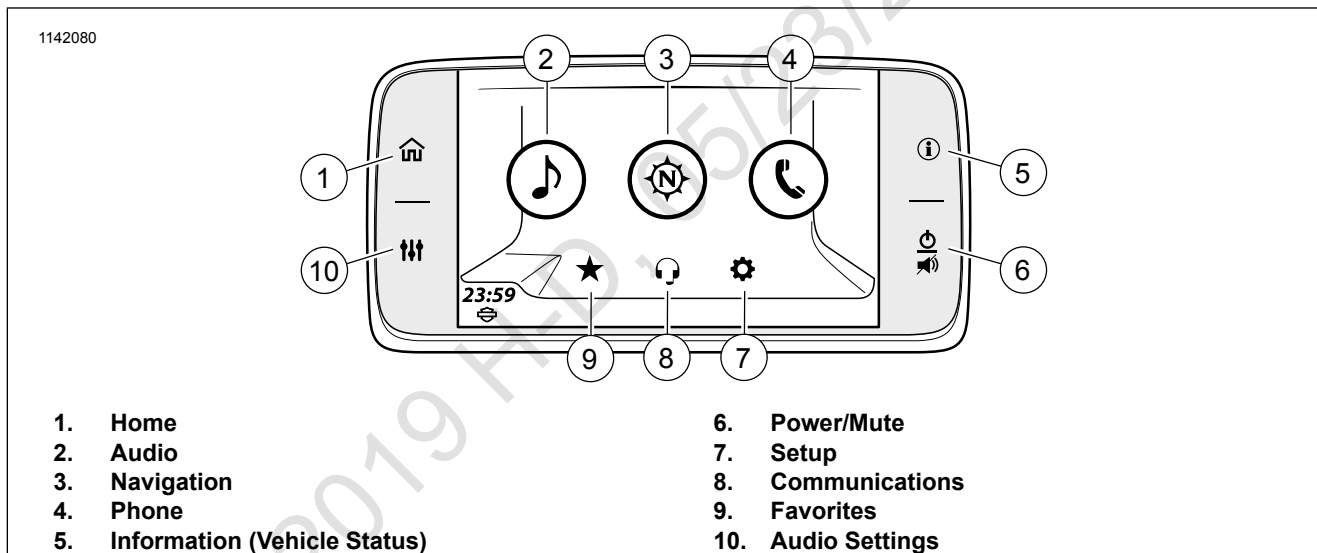

Figure 33. Faceplate Home Screen Selections

SCREEN MENU BAR

Many screens on have a menu bar at the top of the screen. The menu bar and its components change according to the screen being displayed.

Icons: Some menu bars contain a selectable icon on the right, left or both sides of the source field.

Title: The title of the screen or function is located in the center of the menu bar. Some of the screen titles are selectable, used for typing in data or informational.

Figure 34 shows the media and menu icons along with the source field selected to FM tuner. All of these items are located in the Menu Bar.

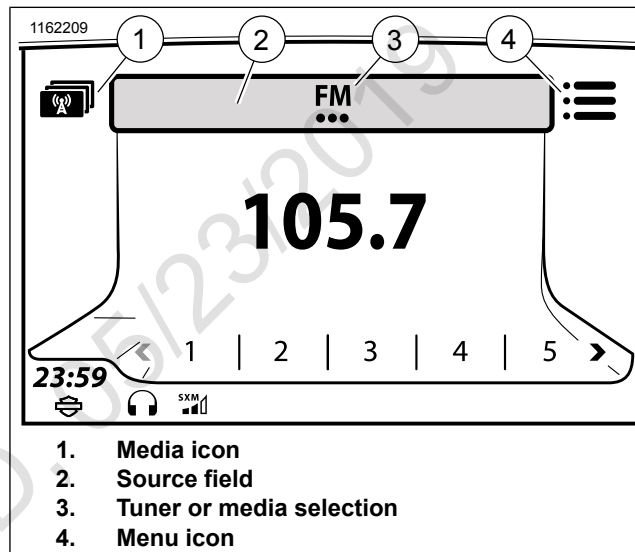

Figure 34. Screen Menu

CHECKBOX AND MULTISELECT

See Figure 35. Some options are selected or enabled with a checkbox (1).

For multiselect (2), repeatedly press the icon or Cursor/Select switch until the desired selection is displayed.

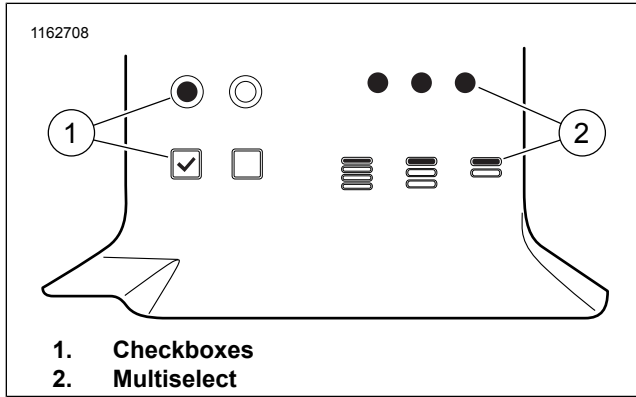

Figure 35. Checkboxes and Multiselect

SCROLL CONTROLS

See Figure 36, Figure 37 and Figure 38. Scroll controls are displayed on the screen when there is more than one page of available options. Using your finger on the touchscreen: Drag, Swipe or Touch to navigate to available options. The Cursor/Select switch may be used to scroll through multiple pages of options. Press and hold the Drag or Touch scroll controls to rapidly scroll through long lists.

Some screens have a center icon on the right side for functions such as letter jump, information, editing or reordering of a list.

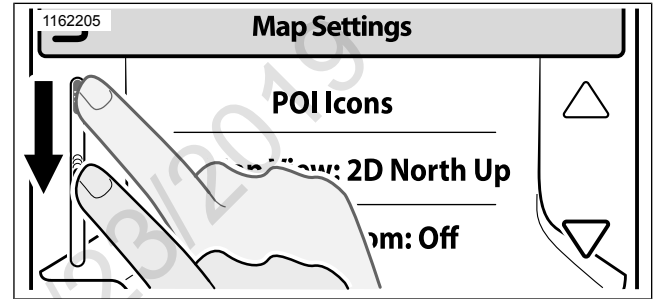

Figure 36. Drag

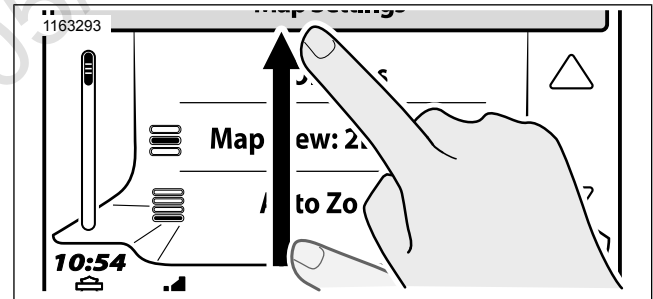

Figure 37. Swipe

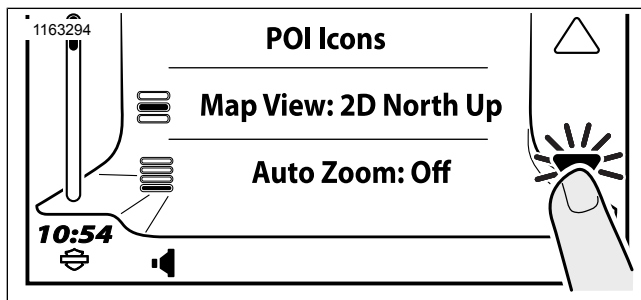

Figure 38. Touch

Table 25. List Function Buttons

BUTTON	NAME	DESCRIPTION
	Menu button	Opens a menu of additional options. Select the button again to return to the original screen.
	Settings/Setup	Opens a menu of additional settings. Select the button again to return to the original screen.
	Search	Opens up search bar.
	Return to previous	Select this button to return to the previous screen.

Table 25. List Function Buttons

BUTTON	NAME	DESCRIPTION
	Letter jump	Jumps to a selected location within the list. For example, to jump to entries starting with the letter 'S', select the letter jump button, then select 'S' from the keyboard.
	Information	Displays more information related to the list contents.
	Edit	Select this button to view or edit information related to the screen contents.
	Delete	Deletes data associated with the list (such as all recent destinations).

KEYBOARD

The keyboard is used for selecting navigation destinations, searching media files, saving contact information or entering other data into the radio when needed. The keyboard is operated by touchscreen or by using the Cursor/Select hand control switch to select letters.

The radio supports a full size keyboard or a large keyboard.

The large keyboard may be more suitable for use when wearing riding gloves. When using the keyboard, some letters may be blanked out. This is a feature of the smart speller,

which only enables valid strings of letters according to the entries in the database.

Input is displayed in the title bar. Select the icons for numbers, symbols or extended characters to display keypads with additional characters as needed. When finished with a keyboard entry, select OK.

1. **Navigate:** Home > Setup.
2. **Select:** Keyboard multiselect icon to select the keyboard type.
 - a. **Full Keyboard:** See Figure 39. When input is required, the screen displays a full keyboard with alphabetically arranged characters A-Z.
 - b. **Large Keyboard:** See Figure 40. When input is required, the screen displays a keypad with larger icons. Use the keypad selectors on the right side to display different portions of the alphabet (A-I, J-R or S-Z).

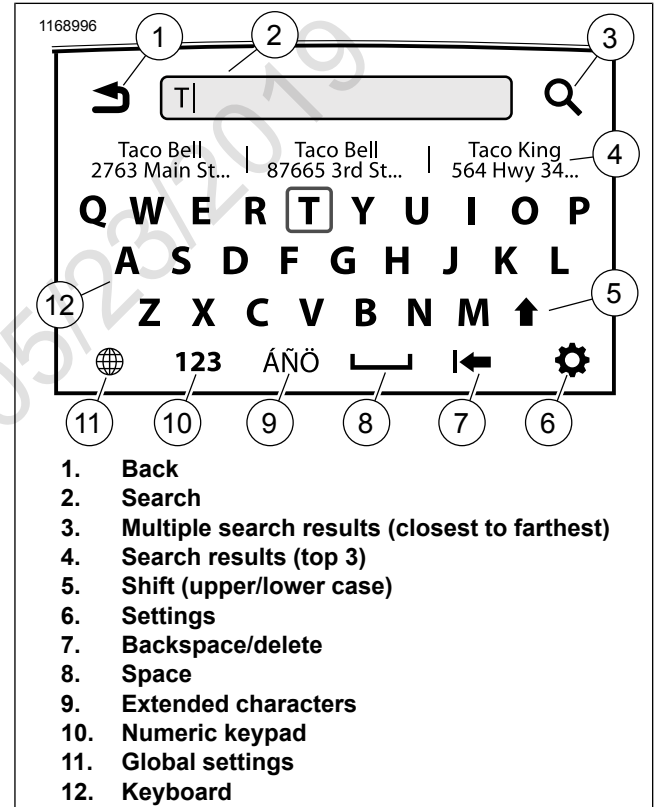

Figure 39. Full Keyboard

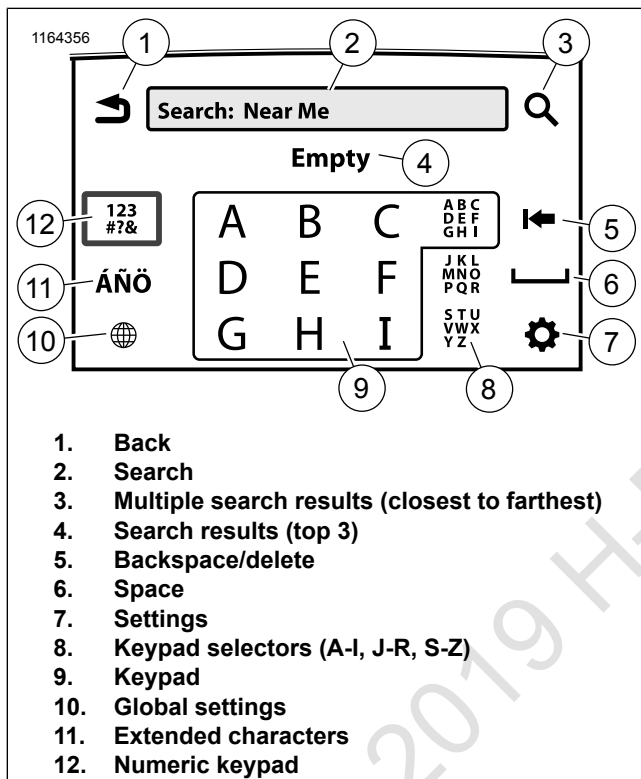

Figure 40. Large Keyboard

SMART SPELLER

The smart speller assists you when entering information into the radio. When entering information (such as a search for a navigation address), the keyboard only enables strings of letters that match the entries in the database.

After a number of letters have been entered, the system will predict the word or location that you are trying to enter by providing matching data from the database. For example, entering "ROCH" could cause the system to suggest "ROCHESTER".

The smart speller can also accept partial entries. If pressing OK with only a partial string of text, the radio will provide a list of items that begin with that text. For example, entering "SAN" and pressing OK could provide a list including "SAN FRANCISCO" and "SANTA ANA".

The smart speller can also assist when entering multiple words. Entering the first few letters of each word, separated by a space, will cause the system to respond with matching words. For example, entering "N D" (including space) could cause the system to respond with "NORTH DAKOTA".

VOLUME CONTROLS

A volume indicator is shown when the rider or passenger presses the volume control switch.

Rider (controls on handlebar): Adjusts the volume level for the speakers and the rider headphones (if active).

Passenger (on Tour-Pak equipped models): Adjusts the volume level for the passenger headphones only.

If the volume controls are pressed during a prompt or a specific function (such as during voice recognition, navigation prompt, CB or intercom activity), the volume for that particular function will be changed and displayed on the screen.

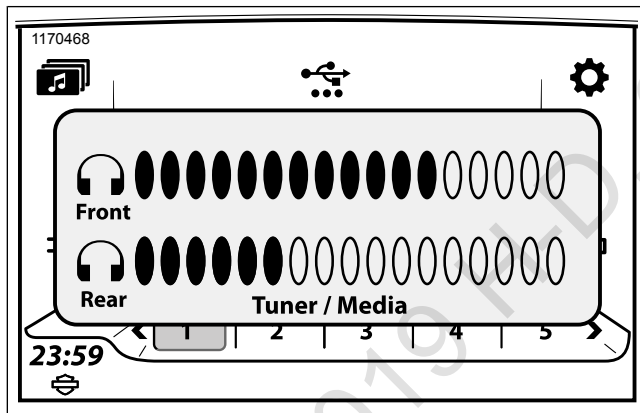

Figure 41. Adjusting Headset Volume

POPUP SCREENS

The radio displays popup screens to explain when a feature is unavailable, display a low fuel message, indicate an incoming phone call, and so on. These screens may interrupt normal system operation. Some screens require a choice (Yes/No) or require confirmation (OK). Select the icon to acknowledge the message or activate the feature.

LOCKOUT SCREENS

Some screens, features or menu items may be locked out or unavailable, such as when the vehicle is in motion.

To operate the features, follow the guidance that is provided on the popup screen. If necessary, use hands-free voice recognition commands or safely park the vehicle to perform the task.

STATUS BAR

See Figure 42. The status bar is at the bottom of the screen. It displays the clock and status icons in nine available slots. The icons are informational and not selectable.

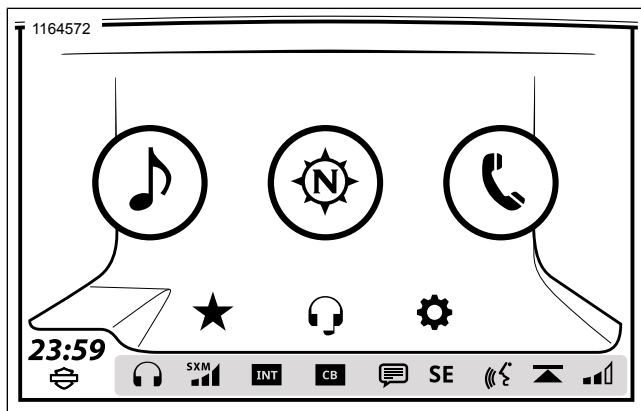

Figure 42. Status Bar

Table 26. Status Bar Icons

ICON	NAME	FUNCTION
	Speakers not muted	Music/media is playing through the speakers.
	Speakers muted	Music/media is routed to the speakers. Speakers are muted.
	Headsets not muted	Music/media is playing through the headsets.
	Headset is Bluetooth connected	Bluetooth device is connected. Music/media is routed to the wireless headset speakers.
	Headsets muted	Music/media is routed to the headsets. The rider headset is muted.

Table 26. Status Bar Icons

ICON	NAME	FUNCTION
TA	Traffic Announcement	The tuned RDS station is actively broadcasting an audio traffic announcement (select international markets only).
TP	Traffic Program	The tuner is set to an RDS station that regularly broadcasts traffic bulletins (select international markets only).
SXM	SiriusXM Signal Strength	SiriusXM satellite signal strength (3 bars).
INT	Intercom microphone idle	Intercom is turned on, but not currently in use.
INT	Intercom microphone active	Intercom is actively in use (PTT switch pressed or VOX activated).
	Harley-Davidson Bar & Shield	Symbol is displayed on the left of the status bar.
CB	Citizen Band (CB) idle	CB is turned on. Not currently transmitting. No CB signals are being received (squelch not broken).
CB	CB active	CB is transmitting or incoming CB signal is being received (squelch has been broken).
	Bluetooth	Bluetooth device is connected. Not displayed when Roaming, New Messages, Low Battery or Phonebook icons are shown.
	Roaming	Bluetooth-connected phone is in a roaming area.
	New Messages	Bluetooth-connected phone has received a text message.
	Low Battery	Bluetooth-connected phone has a low battery.

Table 26. Status Bar Icons









ICON	NAME	FUNCTION
	Phonebook	Bluetooth-connected phone is downloading phonebook data to the infotainment system.
	Voice Recognition active	Voice recognition switch has been pressed. System is prompting or processing voice commands.
	Voice Recognition not ready	Voice recognition system is initializing.
	Media paused	Media is paused. Press POWER/MUTE switch to resume audio.
	Scan up	System is scanning up, briefly dwelling on each active frequency or media file.
	Scan down	System is scanning down, briefly dwelling on each active frequency or media file.
	Seek up	Tuner is seeking up for the next active frequency.
	Seek down	Tuner is seeking down for the next active frequency.
	Phone Signal Strength	Bluetooth-connected phone signal strength (3 bars).
N	North (direction)	Navigation system has determined the vehicle is traveling north.
S	South (direction)	Navigation system has determined the vehicle is traveling south.
E	East (direction)	Navigation system has determined the vehicle is traveling south.
W	West (direction)	Navigation system has determined the vehicle is traveling west.

Table 26. Status Bar Icons

ICON	NAME	FUNCTION
NE	Northeast (direction)	Navigation system has determined the vehicle is traveling northeast.
NW	Northwest (direction)	Navigation system has determined the vehicle is traveling northwest.
SE	Southeast (direction)	Navigation system has determined the vehicle is traveling southeast.
SW	Southwest (direction)	Navigation system has determined the vehicle is traveling southwest.

SYSTEM SETUP

Configure the system settings before riding the motorcycle, with the motorcycle stationary and set to accessory mode. Adjust the options to match your personal riding style, and to make best use of any features or devices that you may be using. If there are problems with any features in the radio, first check the relevant settings.

Most settings are similar for all radios. However, some features or selections may be unique or unavailable on some vehicles. Some settings may also be specific for particular countries or regions. See Features and Specifications (Page 21) for more information about the features available on your motorcycle and in your region.

If audio accessories have been added to the motorcycle, see the instruction sheets for proper configuration and operation of those accessories.

SETUP MENU

See Figure 43. Some of the settings may be disabled or not displayed, depending on the radio type and region. For a list of all the categories that can be configured, refer to Table 27.

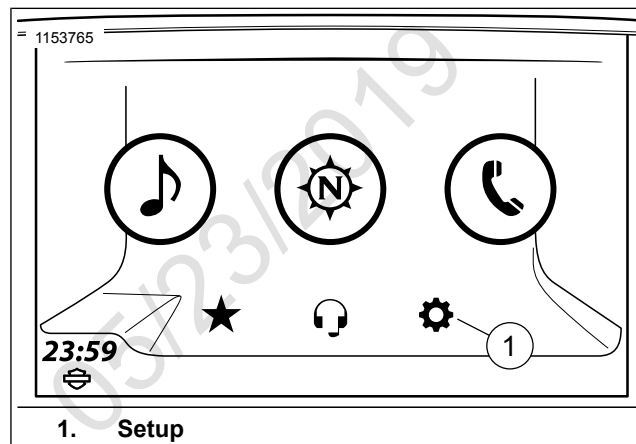

Figure 43. System Setup

Table 27. System Setup

Selections	Settings
<p>1 [Audio Settings]</p> <p>Options for:</p>	<p>Select: Treble, Bass, Fade, Audio Routing, Volumes</p> <p>Audio Routing: Select speaker or headset for directed audible output.</p> <ul style="list-style-type: none"> • Media/Tuner • Phone/Com • Prompts/Nav <p>Volumes</p> <ul style="list-style-type: none"> • Speaker (Media/Tuner, Prompt/Nav, Phone, Beep, CB) • Rider Headset (Media/Tuner, Prompt/Nav, Phone, Intercom, CB) • Passenger Headset (Media/Tuner, Prompt/Nav, Phone, Intercom, CB) • AVC Speed (Off, Levels: 1, 2, 3, 4) • Enable Nav prompts (on or off)
<p>2 [Display]</p> <p>Options for:</p>	<p>Select: Screen Brightness, Button Brightness, Colors</p> <p>Screen Brightness: Manual or automatic</p> <p>Button Brightness: Plus or minus</p> <p>Colors:</p> <ul style="list-style-type: none"> • Automatic, Day, Night • Theme (Default, orange, blue, green, red, purple) • High Contrast Colors

Table 27. System Setup

Selections	Settings
3 [Global Presets]	Select: Enabled or Disabled (select up to pages 4)
4 [Keyboard]	Select: Full or Large
5 [Bluetooth Setup]	Select: Bluetooth (default is OFF), List Paired Devices, Ring Tones
6 [Wireless Headset Setup]	Select: Pair/Manage Rider Headset, Pair/Manage Passenger Headset, Enable/Disable
7 [Units]	Select: English or Metric
8 [Clock]	Select: Daylight Savings Time (on or off), Clock Format (12 or 24 hour), Time Set (GPS or manual), Time Zone
9 [Rear Controls]	Select: Enabled or Disabled
10 [System Information]	Select: Software, Hardware, EQ, Navigation, XM Subscription, Reset
11 [Language]	Select: English (US), English (UK), French (France), French (Canada), Spanish (Spain), Spanish (Mexico), Portuguese (Portugal), Portuguese (Brazil), Italian, German, Russian, Czech, Polish, Dutch, Turkish, Japanese
12 [Projection Mode]	Select: On, Off

LANGUAGE

Navigate: Home > Setup > Language.

The system can be configured for any of the languages shown in Table 27. The selected language affects the text displayed on the screen, voice prompts from the system, and voice recognition features. To make sure that the system works properly for your use, select the proper language and dialect as applicable.

SCREEN BRIGHTNESS

- Navigate:** Home > Setup > Display > Screen Brightness.
- To switch between manual and automatic:
 - Automatic:** Check the **Automatic** checkbox. The screen brightness automatically adjusts according to the ambient light measured by the sensor in the speedometer.
 - Manual:** Uncheck the **Automatic** checkbox. Adjust the brightness level.

BUTTON BRIGHTNESS

1. **Navigate:** Home > Setup > Display > Button Brightness.
2. Adjust the brightness level.

NOTE

- The brightness settings do not affect the brightness of vehicle instruments, illuminated hand control switches (on select models) or other accessories.
- The faceplate button lighting remains off when the radio is in Day Colors mode.

COLORS

Colors

1. **Navigate:** Home > Setup > Display > Colors.
2. See Figure 44. Press the **Colors** multiselect icon until the desired color mode is displayed.
 - a. **Day Colors:** Screen shows brighter colors.
 - b. **Night Colors:** Screen shows darker subdued colors. Navigation map is also shown in night color scheme. No other background colors can be selected while in night color mode.

- c. **Automatic Colors:** Screen automatically adjusts day/night color modes according to ambient light measured by the sensor in the speedometer.

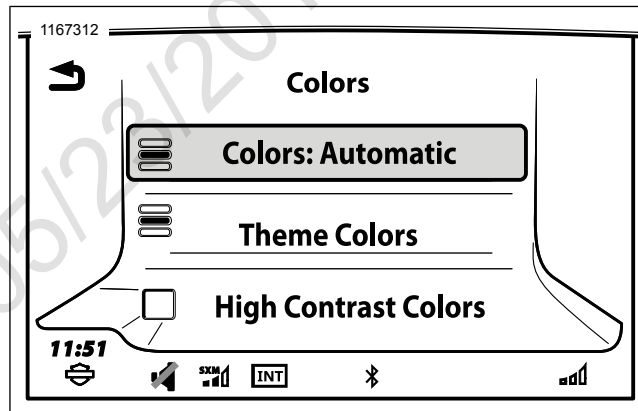

Figure 44. Colors

Theme

1. **Navigate:** Home > Setup > Display > Colors > Theme Color.
2. Scroll through list until desired color is selected.
 - a. **Select:** Default, Orange, Blue, Green, Red, Purple.

High Contrast

High contrast day colors can be activated to enhance visibility of the screen in bright sunlight.

This feature is activated through the color settings or by holding the **Back switch** for five seconds on the right hand control. The feature cannot be activated while the display is showing night colors.

1. **Navigate:** Home > Setup > Display > Colors.
2. With **Day Colors** or **Automatic Colors** selected, check the **High Contrast Colors** checkbox.

ENGLISH UNITS/METRIC

1. **Navigate:** Home > Setup.

NOTE

The English unit/metric selection also affects how units are displayed in the odometer.

2. Press the multiselect icon until the desired unit type is displayed.
 - a. **English Units:** Measurements are displayed as miles, yards, feet, mph, gallons, degrees F (Fahrenheit) and PSI (pound per square inch).
 - b. **Metric:** Measurements are displayed as kilometers, meters, km/h, liters, degrees C (Celsius) and kPa (kilopascals).

CLOCK

1. **Navigate:** Home > Setup > Clock.
2. **Manual Time Adjustment:**
 - a. **Manual mode selected:** Manually adjust the clock to the current time with the (+) and (-) controls.
 - b. **GPS mode selected:** An offset can be applied to the GPS time. The offset is shown next to the time setting.
3. **DST (Daylight Savings Time):** Does not automatically account for daylight savings time when time set is in GPS or Manual mode. Enable **DST** to advance the clock one hour (during spring in the northern hemisphere) and disable to return to the original time.

4. **12/24 Hour Format:** Press multiselect icon to choose 12-Hour or 24-Hour clock mode.
5. **Time Mode:** Press the multiselect icon to choose GPS or Manual.
 - a. **GPS** Automatically synchronizes the clock with data from incoming GPS signals. GPS time is only available on radios with navigation.
 - b. **Manual** Time is manually entered.
 - c. **RDS** Automatically synchronizes time with radio stations broadcasting RDS data. RDS is only available on radios within regions that support RDS operation.

NOTE

*Time zone will automatically default to **Zone (AUTO)** when GPS is selected as a Time Mode.*

6. **Time zone:** Select time zone. For GPS time, AUTO causes the clock to adjust to the time zone for the vehicle location. The clock updates as the motorcycle passes into other time zones.

SPEAKER/HEADSET SELECTION

1. See Figure 45. **Navigate:** Home > Setup > Audio Settings > Audio Routing.
2. For each category shown, select whether the audio routes through the headsets or speakers.
 - a. **Media/Tuner** Tuner stations, SiriusXM channels and media files.
 - b. **Phone/Com** CB, intercom and phone.
 - c. **Prompts/Nav** Voice recognition, navigation prompts, text-to-speech and other audio feedback from the radio.

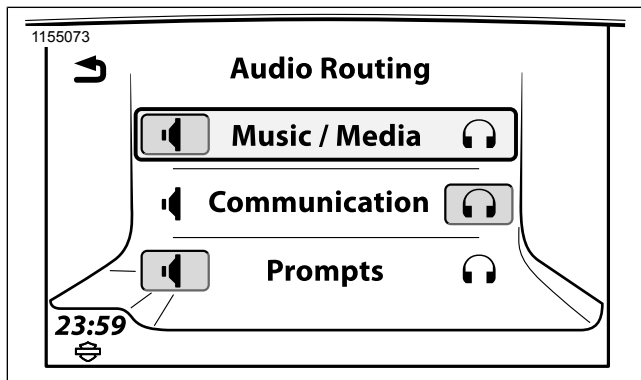

Figure 45. Speaker or Headset

AUDIO SETTINGS: BASS/TREBLE

1. **Navigate:** Home > Setup > Audio Settings.
2. Adjust the Bass and Treble settings using the (+) and (-) controls. The tone settings are applied for all audio output through the speakers and headsets.

FADE

NOTE

If the audio configuration is such that no front/back fading is possible, then the vertical bar that slides left and right would not be shown on-screen. Similarly, if no top or bottom fading

is possible, then the horizontal bar that slides up and down would not be shown on-screen.

The fade crosshair moves to the pressed position and set appropriate fade levels. Based on external amp configuration, the horizontal or vertical axis may not exist.

The fade setting adjusts the balance of volume between the front and rear speakers. By default, the fade is set at the center with an equal balance of volume.

The fade setting does not affect headset or microphone audio levels. Fade does not apply to models without rear speakers.

1. **Navigate:** Home > Setup > Audio Settings > Fade.
2. Adjust the front to rear fade.
 - a. **Fade adjustment (typical):** Press the R (rear) or F (front) controls to adjust the balance of the speaker volume between the front and rear speakers. The center circle indicates an equal balance of volume to both front and rear speakers.

- b. **Graphical fade adjustment (select models):**
Adjust the front to rear sound balance by pushing left or right cursor controls. The fade adjustment line displays the balance of sound between the front and rear speakers. The center dashed line represents the equal balance of volume for front and rear speakers. Vehicles with lower speakers will have a horizontal line to adjust balance between the upper and lower speakers.

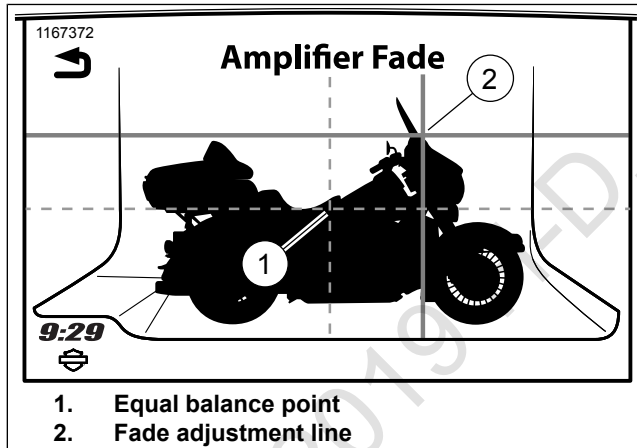

Figure 46. Graphical Fade Adjustment (Select Models)

NOTE

Fade will be removed when speaker configuration does not support Fade settings.

SPEED VOLUME

The speed volume setting adjusts the volume according to vehicle speed. This function allows the volume to be set to a comfortable level while the motorcycle is stopped or traveling slowly. The volume automatically increases to compensate for engine, wind and other ambient noise factors as vehicle speed increases.

The speed volume setting affects the voice activation (VOX) of the intercom. This prevents ambient noise from activating VOX transmissions when at greater speeds. It also prevents the need to continually adjust the VOX sensitivity setting.

Speed volume is also known as automatic volume control (AVC) on previous Harley-Davidson sound systems.

1. **Navigate:** Home > Setup > Audio Settings > Volumes > Speed Volume.
2. Adjust speed volume to one of four different levels. Each level defines the amount of volume that is added as vehicle speed increases.
 - a. If not required, speed volume may be turned OFF.

NOTE

- *Setting speed volume to the lowest level effectively turns off this feature. The volume remains constant while riding. However, the radio has equalizers with dynamic filters which modify certain frequency bands depending on speed. So there may still be a change in sound as the speed changes, even with speed volume turned off.*
- *The effects of the speed volume will be less noticeable under certain conditions, such as when the volume is already turned up near its maximum setting and bass and treble settings.*

FEEDBACK PROMPTS

The prompt volume affects audible feedback, such as navigation prompts, voice recognition prompts, text-to-speech features and others. Prompt volume can be adjusted by the volume hand controls while the prompt is playing.

1. **Navigate:** Home > Setup > Audio Settings > Volumes > Speaker Volumes.
2. **Select:** Media/Tuner, Prompt/Nav, Phone, CB, Beep.
3. Adjust volume by pressing (-) to decrease sound or (+) to increase sound.

REAR CONTROLS

1. **Navigate:** Home > Setup > Rear Controls.
2. Select checkbox to enable audible.
 - a. **Checked:** All passenger controls on the side of the Tour-Pak function normally.
 - b. **Unchecked:** The passenger volume and PTT controls continue to operate normally. However, the MODE/UP/DN switch is disabled. The passenger cannot change audio sources or tune/seek to other channels or songs.

GLOBAL PRESETS

The global preset feature shows a common set of presets for all audio sources. Presets for all tuner band stations (AM, LW, MW, FM, WB), media files and SiriusXM channels are commonly displayed on all audio source screens. This allows easier access to the most commonly used channels and media, without having to manually change to different devices or audio sources. When enabled, the system supports up to 20 global presets.

NOTE

When global presets are used for media files those presets will be grayed-out and unavailable without the media connected.

When global presets are not enabled, each tuner band or media device will only display its own unique presets. The total number of presets is different when global presets are not enabled. CB channels, phone contacts and navigation destinations cannot be stored as global presets. See AM-FM-WB Radio (Page 75) for more information.

1. **Navigate:** Home > Setup > Global Presets.
2. See Figure 47. **Select:** Enable checkbox.
3. Adjust by pressing (-) to decrease or (+) to increase page count. Select up to four pages.
4. **To set a global preset:** See Figure 48. Select the desired audio source (tuner station, media file or SiriusXM channel). Press and hold the desired preset icon to store the new preset.

5. **To select a global preset:** While displaying any audio source, select the desired preset. The system changes to the necessary band or media device to play the selected preset.

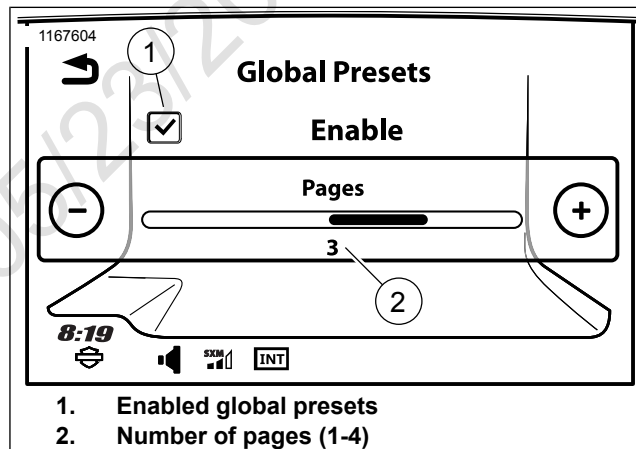

Figure 47. Global Presets

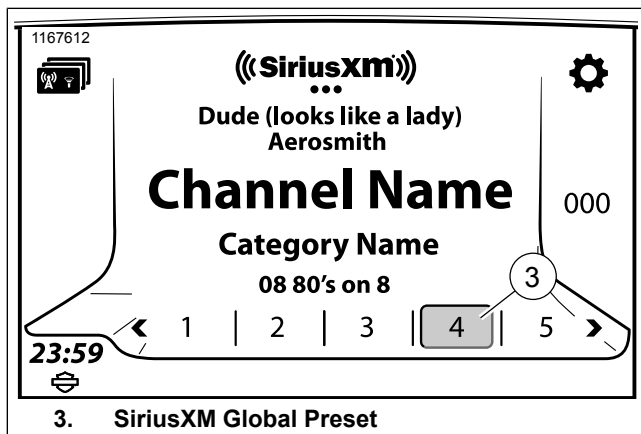

Figure 48. Setting Global Preset

BLUETOOTH

See the Bluetooth (Page 112) section and other applicable sections for configuration and operation of Bluetooth devices.

RING TONES

See Ring Tone (Page 132) for setting up or installing a new ring tone.

SIRIUSXM

See Satellite Radio (Page 93) for setting up and subscribing to SiriusXM on equipped vehicles.

TRAFFIC

See Traffic (Page 164) to set up and operate traffic features.

SYSTEM INFORMATION

1. **Navigate:** Home > Setup > System Information.
2. **Select:** Software, Hardware, EQ (equalizer), Navigation, XM Subscription, Reset or Software License.

Table 28. Software Update

Selections	Result
Software	Shows the current software version installed on the radio. Software updates for Boom! Box are available on www.harley-davidson.com or Software Updates (Page 72)
Hardware	Shows the Harley-Davidson part number, supplier part number and a unique serial number for the radio. Use the Harley-Davidson part number along with the information in Specifications (Page 24) to determine the features available on this radio.

Table 28. Software Update

Selections	Result
EQ	Shows the equalizer (EQ) file installed in the radio. This is based on the vehicle, fairing type and speaker configuration. The EQ may be updated by the dealer when adding new accessory speakers to the motorcycle.
Navigation	Select: Software, Map Database, Dealer Database, Export for Update
	Software: Shows the current software version for the navigation software engine.
	Map Database: Shows the current map database version that is installed in the radio.
	Dealer Database: Shows the current dealer database version that is installed in the radio.
	Export for Update: Used when updating or purchasing new map sets. See Navigation Database and Software (Page 173) to install or update maps.
XM Subscription	Select: Radio, Specialty Services
	Radio: The Radio Services subscription status is displayed with an ESN number and SiriusXM phone number for assistance or activation.
	Specialty Services: The subscription status for each service (traffic, fuel, weather and forecast services) is displayed with an ESN number and SiriusXM phone number for assistance or activation.
Reset	Select: Privacy Reset, Reset to Factory Defaults
	Privacy Reset: A privacy reset can be performed by the dealer to remove all personal information from the radio memory. This can be useful when selling the motorcycle or when completely re-configuring the radio with new personal settings.
	Reset to Factory Defaults: A factory restore can be performed by the dealer to restore the radio to its original factory settings. This removes all user settings in radio. See an authorized Harley-Davidson dealer to have this service performed.
Software License	List of all open source licenses

SOFTWARE UPDATES

Harley-Davidson periodically provides software updates for the radio on www.harley-davidson.com.

NOTE

*When looking for radio hardware part number information, the eight-digit base number is only required. For example, H-D Part#: **76000783**. Disregard any suffix attached to the base H-D Part# with an alpha designator.*

Confirm Software

Check that you are using the latest version of software and update the software when a newer version is available.

1. **Navigate:** Home > Setup > System Information > Hardware.
 - a. Record the radio's **H-D Part#**.
 - b. Refer to Table 29. Locate and match your radio's **H-D Part#**.
2. Check for the latest radio software version on the Infotainment Support Resources page in <https://serviceinfo.harley-davidson.com> (all markets).

3. **Navigate:** Home > Setup > System Information > Software.
 - a. Compare the software version in the radio with the latest version.
 - b. **Same Version Number:** You have the latest software available. There is no need to update.
 - c. **Higher Version Number:** Continue with **Update Software** procedure.

Update Software

Updates can be done by using the following procedure or by bringing the vehicle to a Harley-Davidson dealer.

NOTE

*Downloading software updates requires a computer platform loaded with the Windows operating system. **Do Not** use Apple products for downloading updates.*

NOTE

Password encrypted drives are not compatible. Make sure that there are no other files on the USB drive.

1. Download Requirements:
 - a. **USB Drive Storage Capacity:** 16 GB (minimum).
 - b. **Importing GPX File:** USB Drive formatted to FAT32 or exFAT.
 - c. **Performing Software Update:** USB Drive formatted to NTFS, FAT32, or exFAT.
4. Copy the **.ISO** file to the root directory (the first or top directory) of a USB drive.
5. Set vehicle ignition:
 - a. **Keyed ignition motorcycle:** Turn the vehicle ignition switch to ACCESSORY.
 - b. **Keyless ignition motorcycle:** With the OFF/RUN switch turned off, press and hold the trigger switch until the vehicle enters accessory mode.

NOTE

Do not interrupt the installation process. Leave the vehicle and radio turned on, and keep the USB drive installed until the installation process is complete.

2. Download the latest software version from the website.
 - a. Select update for radio (GTS or GTS (CVO)).
 - b. Refer to Table 29. Select proper region/vehicle configuration, if applicable.
3. Unzip the software package to a folder. The folder includes an installation file with an .ISO extension (.txt files are not needed).

NOTE

If the incorrect file is on the USB drive, the radio displays an error message.

6. Turn on the radio.
7. Connect USB drive to vehicle USB port.
 - a. The radio detects the new software and prompt for the update.
 - b. **Select:** Yes.
 - c. The software installation begins.

- d. The display prompts to remove the USB drive when the update is complete.

Table 29. Boom Box GTS Software

H-D Part No.	Software and Application
76000783	
76000779	BOOM! BOX GTS - North America (DOM)
76000786	
76000796	
76000784	
76000780	BOOM! BOX GTS - Europe (HDI)
76000787	
76000797	
76000785	BOOM! BOX GTS - Rest of World (ROW)
76000781	

PRIVACY RESET

A privacy reset can be performed by the dealer to remove all personal information from the radio memory. This can be useful when selling the motorcycle or when completely reconfiguring the radio with new personal settings. The reset will remove information and history from the radio such as phone pairing, downloaded phone books, call history, navigation history, favorites and presets. A privacy reset does not affect other basic settings like the clock or audio configuration. See an authorized Harley-Davidson dealer to have this service performed.

74 Setup

Information accurate as of January 28th, 2019. Go to <https://serviceinfo.harley-davidson.com> to check for the latest version.

FACTORY RESTORE

A factory restore can be performed by the dealer to restore the radio to its original factory settings. This removes all user settings in radio. See an authorized Harley-Davidson dealer to have this service performed.

AM-FM-WB RADIO

Tuner

The radio has a multi-band stereo receiver with tune and scan functions. The tuner supports RDS/RBDS data display (according to vehicle configuration). The tuner can be configured to search for particular program types (such as country music or news programming). In some radios, the system can accumulate a list of stations within range, along with current song or program being played.

See Figure 49 for a description of Tuner Screen components.

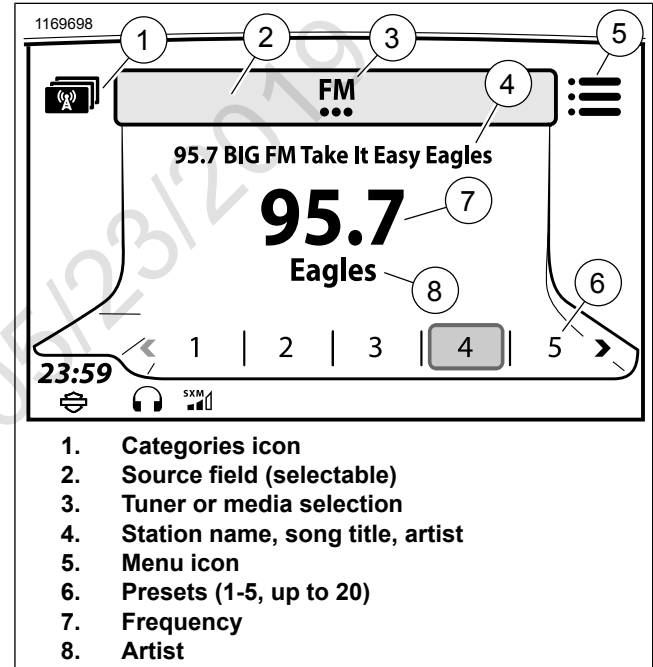

Figure 49. Tuner Screen

Selecting a Band

Radios support different frequency bands according to region and radio type.

1. **Navigate:** Home > Audio.
2. **Select:** Source field.
3. **Select:** Desired band (AM, FM, WB or Sirius).

Selecting a Band: Voice Recognition

1. **Select:** Voice recognition switch.
2. Speak the band into microphone "AM, FM, XM or weather band". Media such as Bluetooth Paired device or USB is also available if connected. See Voice Recognition (Page 179).

Tune/Seek/Preset Stations

Tune and Seek are only available from left hand control switch. See Left Hand Control (Page 37).

Preset selection can be made by right hand control switch or touch screen. See Right Hand Control (Page 39).

When tuning or seeking, tuner continues to wrap around at the beginning or end of frequency range.

1. **Navigate:** Home > Audio.

2. Tune (left hand control switch):

- a. **Tap:** Increase or decrease frequency by increments.
 - b. **Long press:** Accelerates up or down through the frequency range until switch is released.
3. **Seek (left hand control switch):** Press for 1 second and release. Seeks up or down frequency range to next station.
 4. **Preset (right hand control switch):** Move switch left or right to scroll through presets. Press switch in to select preset.

Tuning a Station: Voice Recognition

1. **Select:** Voice recognition switch.
2. **Speak:** "Tune to" along with the frequency into microphone (such as "Tune to ninety-seven point one"). The radio automatically tunes to appropriate band (such as AM or FM) according to frequency selected.

Seeking a Station: Voice Recognition

1. **Select:** Voice recognition switch.
2. **Speak:** "Seek Up" or "Seek Down" into microphone.

Scanning Stations

Selecting Scan starts the radio scanning through frequencies. The radio remains on each station for five seconds before continuing scan. If the scan does not find any strong station within two complete passes through band frequencies, the scan automatically cancels.

1. **Navigate:** Home > Audio.
2. **Select:** Menu icon.
3. **Select:** Scan.
4. To select a station, press the Cursor/Select switch on the right hand controls.

Presets

Presets can store preferred radio stations for easy access. The radio has 20 Satellite radio/media, 15 FM/DAB+, 5 AM,

5 LW, 5 MW, 5 WB presets. The radio can also be configured with global presets. See Global Presets (Page 68).

1. Tune to a station.
2. Save station to a preset.
 - a. **Touchscreen:** Press and hold chosen preset until a beep sounds.
 - b. **Cursor/Select Switch:** Highlight chosen preset. Press and hold the Cursor/Select Switch in until a beep sounds.
3. To tune preset in the future, select preset with touchscreen or Cursor/Select switch.

Categories

NOTE

If no categories are selected or recognized, the radio will not stop scanning or seeking.

The FM band can scan for particular types of radio programming (such as news, sports or classical music). When categories are selected, the radio only scans for stations that are broadcasting programs with selected category codes. Not all stations broadcast these codes.

Selecting Categories

See Table 30 for categories available in North America.

See Table 31 for categories available in other regions.

1. See Figure 49. While in FM band, select categories icon (1) to access a list of all available categories.
2. See Figure 50. Select categories (2) from list.
 - a. **Individual categories selected:** Radio scans only stations from selected categories.
 - b. **Clear All (or no categories selected):** Radio scans all stations.
 - c. **Set All:** Radio scans for stations that are broadcasting any of the program types. The radio does not stop on any station unless it is broadcasting a program type code.

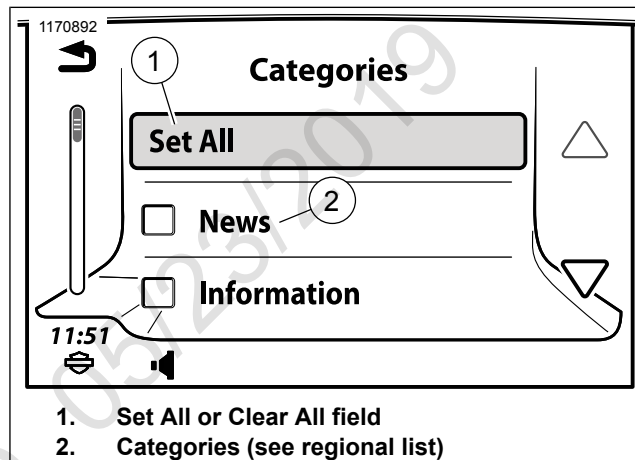

Figure 50. Categories Screen

Table 30. FM Categories: RBDS, North America

OPTION	OPTION
• News	• Classical
• Information	• Rhythm & Blues
• Sports	• Soft Rhythm & Blues
• Talk	• Foreign Language
• Rock	• Religious Music
• Classic Rock	• Religious Talk
• Adult Hits	• Personality
• Soft Rock	• Public
• Top 40	• College
• Country	• Spanish Talk
• Oldies	• Spanish Music
• Soft	• Hip Hop
• Nostalgia	• Weather
• Jazz	

Table 31. FM Categories: RDS, Other Regions

OPTION	OPTION
• News	• Weather
• Current Affairs	• Finance
• Information	• Children's Programs
• Sport	• Social Affairs
• Education	• Religion
• Drama	• Phone-in
• Culture	• Travel
• Science	• Leisure
• Varied	• Jazz Music
• Pop Music	• Country Music
• Rock Music	• National Music
• Easy Listening	• Oldies Music
• Light Classical	• Folk Music
• Serious Classical	• Documentary
• Other Music	

Station List (EU)

Radios equipped with station list feature will have a Stat icon in upper left corner on FM screen. The radio scans and creates a list of all available stations in the FM band. Radios with a dual tuner will continually update the list as stations come in and out of range.

See Figure 51. **Access station list:** Press station categories icon in upper left corner of the FM band screen (if equipped).

See Figure 52. **Select a station:** Use scroll controls and select desired station from list.

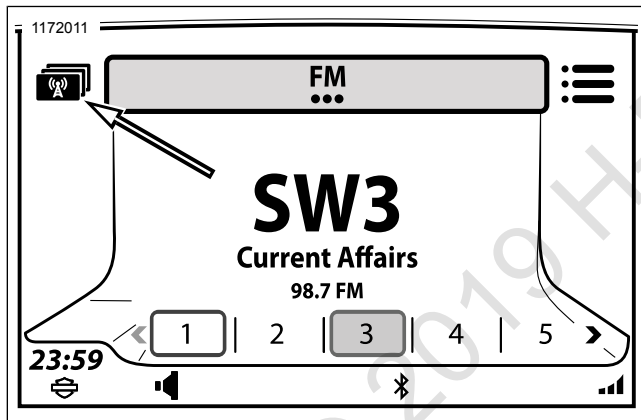
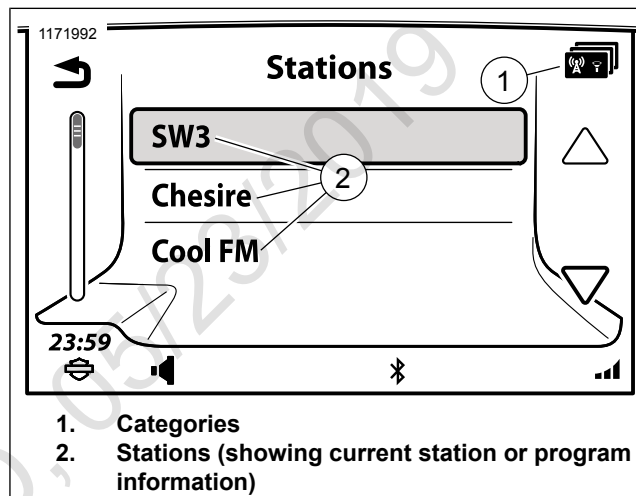

Figure 51. FM Tuner Station List (EU)



1. Categories
2. Stations (showing current station or program information)

Figure 52. Station List

RBDS/RDS

Some radio stations broadcast data which can be used to display station identification, program information and support other features in the radio (depending on the region).

Radio Broadcast Data System (RBDS) is primarily used in North America. Stations broadcasting RBDS typically provide information such as radio station name, artist and song title to the radio.

Radio Data System (RDS) is primarily used in Europe. Stations broadcasting RDS data may also include time updates, weather, traffic and other regional information. Not all radio stations transmit RBDS or RDS data. When RBDS or RDS is unchecked, or if the service is not available, only the radio frequency is displayed.

Enable RDS/RBDS

1. **Navigate:** Home > Audio.
2. **Select:** Menu icon.
3. **Select:** RDS or RBDS checkbox.

RDS Features: For dual tuner radios with RDS capability, three separate RDS features can be enabled.

- **Alternate Frequency Switching (AF):** The radio monitors signal strength of other stations playing the same program. The radio automatically switches to another station if signal quality is better.
- **Regionalization (REG):** Some radio stations split their program into separate regional programs on different frequencies. Regionalization automatically uses frequencies of regional related stations for alternate frequency jumps.

- **Traffic Program/Traffic Announcement (TP/TA):** The radio monitors stations for traffic announcements. When a traffic announcement is discovered, the radio automatically tunes to station playing the announcement. Traffic Announcement icon (TA) is displayed in the status bar. When finished, tuner returns to its previous operation. The status bar displays Traffic Program (TP) icon when tuned to a station that regularly plays traffic announcements. When enabled, the radio also monitors stations for Enhanced Other Networks (EON) transmissions.

Weather Band

See Table 32. Weather band is supported on radios for North America. Equipped radios can tune to any of seven weather band frequencies. The five weather band presets are originally set to the first five weather band frequencies.

Generally only one weather band station services an area. Using the seek function would take user to the only available station.

In the US, National Oceanic and Atmospheric Administration (NOAA) operates National Weather Radio (NWR) stations across the country. These stations continually broadcast weather announcements using seven different frequencies designated for weather band.

In Canada, Weatheradio Canada broadcasts weather information.

NOTE

RBDS/RDS must be enabled for WB channel to show.

1. Listen to weather band:
 - a. **Navigate:** Home > Audio.
 - b. **Select:** Source field.
 - c. **Select:** WB.
 - d. Use Cursor/Select switch to advance through the seven weather band frequencies or select a preset. See Table 32.

Table 32. Weather Band Channels

CHANNEL	FREQUENCY
WB1	162.400 MHz
WB2	162.425 MHz
WB3	162.450 MHz
WB4	162.475 MHz
WB5	162.500 MHz
WB6	162.525 MHz
WB7	162.550 MHz

Weather Alert

Weather band alert feature is only available on radios built for North America with a CB module.

When weather alert feature is turned on, CB module continuously scans the weather band for an alert tone from weather band stations. The rider can continue to play media, listen to other stations or use other features on the radio. When an alert tone is detected, the radio changes to weather band and tunes to the channel with alert announcement. The alerts indicate extreme weather conditions such as tornados, storms, floods or other environmental warnings. See www.weather.gov for weather band and alert broadcast information.

Turn weather alert ON: See Figure 53. On weather band screen, press the weather alert on/off icon (2).

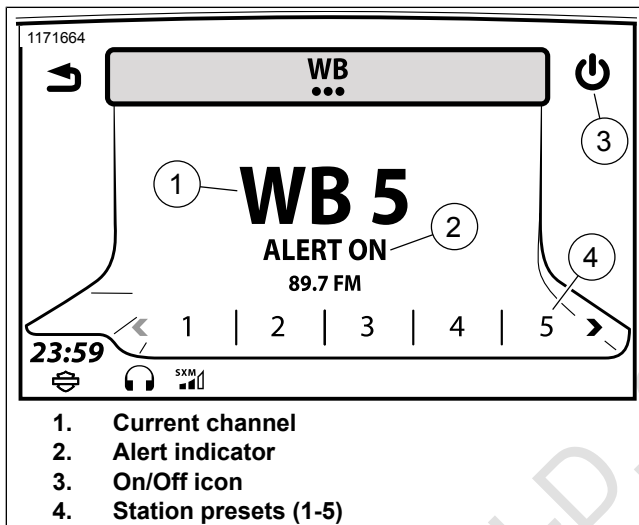

Figure 53. Weather Band

MEDIA

Media Screen

See Figure 54. The Media screen shows the status of the currently playing song. The media screen also displays cover art for the song, if available.

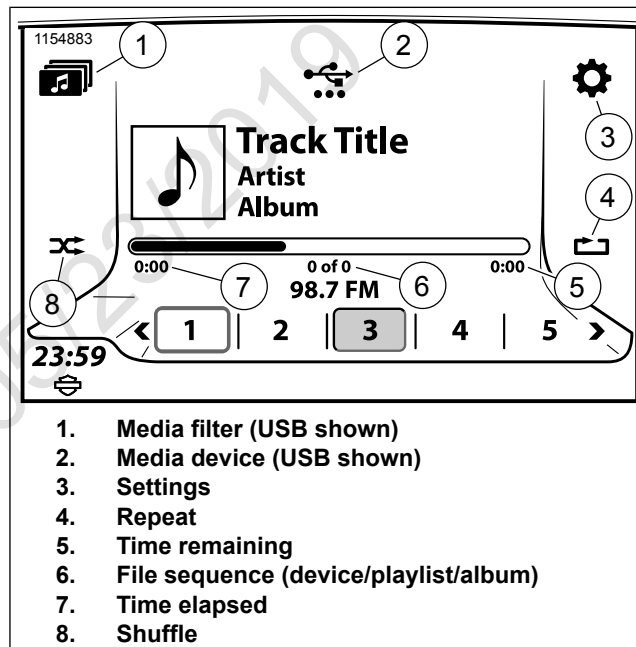

Figure 54. Media Screen

Media Devices

NOTE

Avoid using these characters in naming media files: . : ? " < > | / *

The radio supports various types of USB and Bluetooth-connected media devices. As a general guideline,

support for devices is listed in Table 33. Some features or menus may not be available depending on device, file type or connection type.

For mass storage devices (such as USB drives), the file organization on the device can impact performance. For best performance and indexing of files, store media files at the root directory of the USB device, rather than in multiple levels of folders.

Table 33. Media Device Support

DEVICE	DEVICES SUPPORTED	CONNECTIONS	FILES SUPPORTED	FEATURES OR LIMITATIONS
iPod	iPod supporting iAP2	Apple proprietary connector.	All iPod supported file types	Supports all find features. Ring tone files cannot be downloaded. iPods with a hard drive can be damaged and are not recommended.
USB mass storage device	USB drive (exFAT, FAT32, NTFS, HFS+) or SD card	Direct connection to USB port. USB connector and reader required for SD card.	MP3, MP4, MPEG-4 AAC, M4A, M4B, WAV, WMA	May support find features. NTFS-formatted drives can only be used for read-only functions (such as playing media). NTFS drives will not support functions like ride/trail exports or navigation database updates.

Table 33. Media Device Support

DEVICE	DEVICES SUPPORTED	CONNECTIONS	FILES SUPPORTED	FEATURES OR LIMITATIONS
Media player	USB-connected phone. PlaysForSure compatible device. Media Transfer Protocol (MTP) compatible device.	USB cable.	MP3, MP4, MPEG-4 AAC, M4A, M4B, WAV, WMA	May support find features.
Bluetooth device	Varies. Requires minimum Bluetooth profile interoperability.	A2DP/AVRCP profiles.	Bluetooth device dependent. Bluetooth audio is streamed by the device and not decoded by radio.	No preset capability. File metadata may not be displayed. Audio from an app or internal player can be streamed to radio.

Connecting Media Device: USB

1. Connect media device to the USB port. Use a connector or reader as needed.
2. If the media device is not automatically recognized, check device settings. Some devices need to be configured to connect as a hard drive or as a media device before media files can be accessed. See the device manual.

- If connecting a device for the first time, the radio begins playing the first song found on device. If reconnecting a previously used device, the radio attempts to resume the last played file.
- The radio will begin collecting file information from the device. Some information and features may not be available until the radio has finished synchronizing with the device. The radio will play remaining files in alphabetical order.

Connecting Media Device: Bluetooth

1. Pair the device. See Bluetooth (Page 112).
2. **Navigate:** Home > Audio.
3. **Select:** Source field.
4. Select device from list.

Device Players and Applications: Bluetooth

Streaming audio can be played from an internal player or application on a connected Bluetooth device. The radio can control some features, such as previous or next file selections within some players or applications.

1. With motorcycle stopped, connect with the Bluetooth device.
2. Start the media application or internal player within the Bluetooth-connected device. The audio begins playing through the motorcycle speakers or headsets.

NOTE

The volume level and equalization within the device can affect the streaming volume to the radio. If sound cannot be heard

or is distorted, check the volume within the application or device.

3. Use the Home/Volume/Previous/Next switch and Mute/Power button on the radio faceplate to operate the application or internal player, as applicable.

Selecting Media Device

1. See Figure 55. **Navigate:** Home > Audio.
2. **Select:** Source field.
3. A list of paired or connected devices is displayed. Items are marked with either a USB or Bluetooth symbol.

NOTE

Some bluetooth devices can not be controlled through the radio.

4. Select a device from the list. If connected, the first song from the device begins playing.

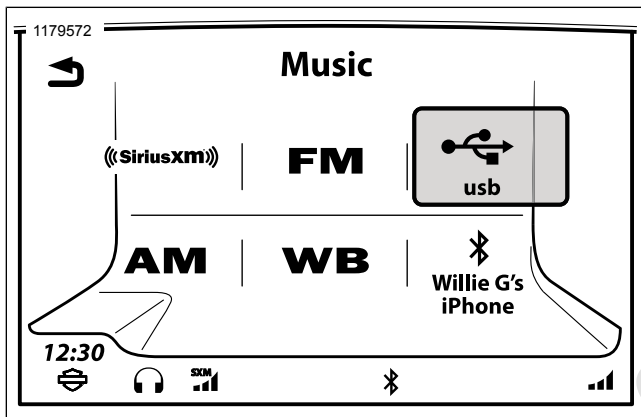

Figure 55. Select Media Device

Play Previous/Next Media File: Previous/Next

The Previous/Next switch on the left hand control will advance to the previous or next song in the device.

Play Previous/Next Media File: Preset

The Cursor/Select switch on the right hand control will advance to the previous or next preset on the radio.

Pause, Rewind or Fast Forward Media File

Pause: Press the Power/Mute button to pause or unpause media.

Rewind: Press and hold Previous switch to the left. Rewinding will accelerate as switch continues to be held.

Fast Forward: Press and hold Next switch to the right. Fast forwarding will accelerate as switch continues to be held.

Scanning Media Files

1. **Navigate:** Home > Audio.
2. **Select:** Menu icon.
3. See Figure 56. **Select:** Scan. The radio begins playing each song on the device sequentially, dwelling on each song for five seconds. The Scan icon is displayed in the status bar.

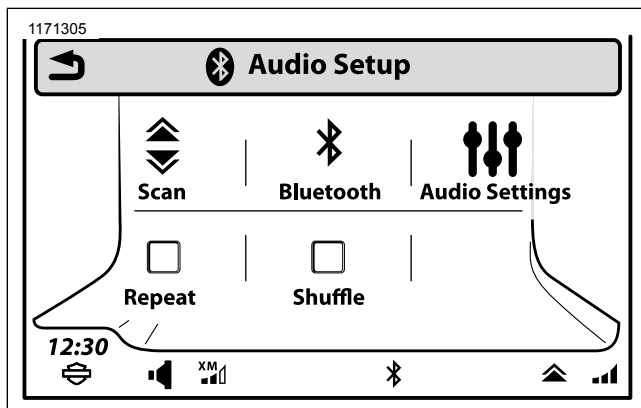

Figure 56. Scan Icon Location (typical)

4. Press any switch to stop the scan.

Repeat Current File

1. **Navigate:** Home > Audio.
2. **Select:** Menu icon.
3. **Select:** Repeat checkbox. The Repeat icon is displayed and the current file will play repeatedly until unselected. Pressing Repeat a 2nd time will allow the radio to continuously play the existing song list.

88 Audio

Information accurate as of January 28th, 2019. Go to <https://serviceinfo.harley-davidson.com> to check for the latest version.

Play Random Files: Shuffle

1. **Navigate:** Home > Audio.
2. **Select:** Menu icon.

NOTE

An iPod may exclude audio books and podcasts from shuffle selection.

3. **Select:** Shuffle checkbox. The Shuffle icon is displayed. The radio will randomly select files from the device.

Play Songs From Track List

The track list shows a full list of all songs on the connected device. When selecting a song from the list, the radio remains in the track list and does not transition back to the media screen. Track lists are not available for Bluetooth streaming media devices.

1. **Navigate:** Home > Audio.
2. **Select:** Menu icon.

3. See Figure 57. **Select:** Track List. A complete list of all songs from the currently selected device, playlist, artist or album is displayed.
4. Select a song from the list to play.

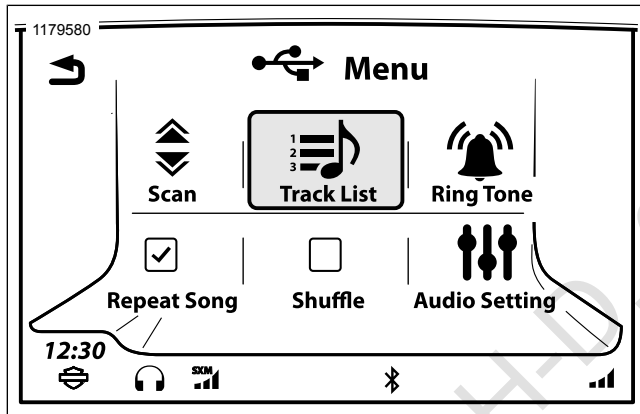

Figure 57. Track List Icon

Media Presets

The radio stores up to 20 presets for each connected device. The screen only shows media presets for the currently connected device. The media presets are retained in memory and are available the next time the media device is connected. Presets are only available for USB connected devices.

Set media preset: With song playing, press and hold one of the presets. When the radio beeps and the preset is stored release preset.

Select media preset: Select desired preset. Song will begin playing.

Finding a Media File

See Figure 58. The Find feature can be used to browse for different types of media files on USB-connected media devices as shown in Table 34. File browsing features are not available for Bluetooth streaming media devices.

1. **Navigate:** Home > Audio.
2. **Select:** Media filters.

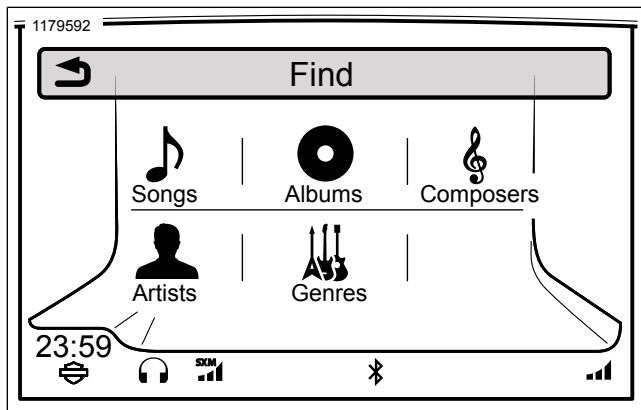

Figure 58. Find Media Selections

Table 34. Finding a Media File

CATEGORY	DESCRIPTION
Artist	Lists all songs by selected artist. Radio will play a selected song, then plays remaining songs by the artist.
Album	Lists all songs on selected album. Radio will play a selected song, then plays remaining songs on the album.
Genre	Lists songs by selected genre.
Song Title	Searches for song by title.

Table 34. Finding a Media File

CATEGORY	DESCRIPTION
Composers	Lists all songs by selected composer. Radio will play a selected song, then plays remaining songs by the composer.
Playlist	List of all playlists on device.
Podcast	List of all podcasts on device (Apple devices only).
Audio Book	List of all audio books on device (Apple devices only).
Video, TV Show, Movie or Music Video	List of video files on device (only audio portion is played).

Finding a Media File: Playlist

A playlist is a file stored on the device which includes a sequential list of songs. All playlists native to the iPod are supported. The radio also supports the following playlist types for other USB-connected devices.

- Windows Media Player Advanced Stream Redirector format (*.asx)
- Windows Media Player Playlist (*.wpl)
- M3U Moving Pictures Expert Group Audio Layer 3 Uniform Resource Locator (*.m3u)
- PLS file (*.pls)

- iTunes XML (*.xml)
- RealPlayer Metadata Package (*.rmp)

NOTE

- *M3U, PLS and WPL playlists only allow relative pathnames to files. Absolute pathnames are not supported.*
- *All XML files on USB mass storage media will be displayed, even if the files are not actually XML-formatted playlists.*

1. **Navigate:** Home > Audio.
2. **Select:** Media filters.
3. **Select:** Playlist.
4. Select item from list.
5. Select song from the playlist. To play the entire playlist, select the first song.

Finding a Media File: Artist, Album, Genre or Composer

1. **Navigate:** Home > Audio.
2. **Select:** Media filters.

3. **Select:** Artist, Album, Genre or Composer to browse.
4. Select item from list.
5. Select song from the list. The radio begins playing files for the artist, album, genre or composer starting at the selected file. To play all songs for this artist, album or genre, select the first song from the list.

Finding a Media File: Song Title

1. Select **Navigate:** Home > Audio.
2. **Select:** Media filters.
3. **Select:** Songs. A full list of all songs on the device is displayed.
4. Select a song from the list. If necessary, select the letter jump icon between the scroll controls and type the first letter of the song name.

Finding a Media File: Podcast

The Podcast category is displayed in the Find menu when a properly configured podcast is identified on the device. An audio file (ID3 tag) must be coded properly to display on the

radio as a podcast. If needed, right-click on the file in iTunes and select the proper option for characterizing the file (movie, music, video, podcast, and so on).

Some files identified as podcasts are not actually podcast files, but just media files. These files may be listed with other song files.

1. **Navigate:** Home > Audio.
2. **Select:** Media filters.
3. **Select:** Podcast.
4. Select a podcast from the list.
5. Select an episode from the list.

Finding a Media File: Audio Book

The audio book option is displayed when audio book files have been discovered on the device. Some audio books are MP3 files which may be listed with other song files.

1. **Navigate:** Home > Audio.
2. **Select:** Media filters.

3. **Select:** Audio book. A list of audio books is displayed.
4. Select an audio book from the list.
5. Select a chapter from the audio book, if applicable.

Finding a Media File: Video, TV Show, Movie, Music Video

The radio can play some types of video files. To minimize distraction, the radio only plays the audio portion of the files.

Files from Apple devices may be categorized as TV Show, Movie or Music Video. Supported video files from a USB device are categorized as Video.

1. **Navigate:** Home > Audio.
2. **Select:** Media filters.
3. **Select:** Video, TV Show, Movie or Music Video.
4. Select a file from the list. Audio from the video file will begin playing.

Selecting Media File: Using Voice Recognition

See Voice Recognition (Page 179) for detailed instructions on all voice recognition commands.

1. **Select:** Voice recognition switch.
2. **Speak:** Artist, Album, Genre, Playlist or Song followed by the name or title to be played.
3. The radio may prompt for more information. Respond to any remaining prompts to select and play the media.

Saving Media File as Favorite

See Favorites (Page 203).

Saving Media File as Ring Tone

NOTE

The media file must be playing.

1. **Select:** Menu. If the current file type is compatible for use as a ring tone, a Ring Tone icon is displayed.

2. **Select:** Ring Tone. The radio will attempt to download the media file for use as a ring tone. The radio allows only one ring tone to be downloaded into the radio. Replace the existing file if necessary.
3. **Select:** OK.

SATELLITE RADIO

SiriusXM Satellite Radio

SiriusXM radio is equipped on select vehicles in North America. See Features and Specifications (Page 21). The radio includes over 200 digital channels of music, news, talk, entertainment and sports. The radio broadcast is over satellite (with ground repeaters) to provide consistent programming and signal quality nationwide without a break in coverage.

SiriusXM specialty services provide weather mapping, weather forecast data, fuel price information and traffic data service. SiriusXM traffic provides information for traffic events and road conditions. This data is integrated with the navigation system to provide speed flow along selected routes and notifications of traffic situations (such as accidents or lane closures).

Optional SiriusXM Accessory

SiriusXM functionality is standard on select vehicles in covered regions. For vehicles not equipped with SiriusXM, the optional SiriusXM accessory can be purchased at www.h-d.com/store or at an authorized Harley-Davidson dealer. See dealer or website for fitment and requirements when adding this accessory.

Follow the instruction sheet procedures or have an authorized Harley-Davidson dealer install the accessory. After installation, use the instructions in this manual to set up, subscribe and operate the SiriusXM features.

Trial Subscription

New vehicles equipped with SiriusXM from the factory include a three-month trial subscription for SiriusXM Radio, Traffic and Travel Link service in regions where service is available. This trial subscription is only available to the original purchaser of a new SiriusXM equipped vehicle. This is not included with SiriusXM modules that may be subsequently purchased or installed by the customer or dealer. Terms and conditions of service may be modified from time to time by SiriusXM. See www.siriusxm.com.

Check Subscription Status

1. **Navigate:** Home > Setup > System Information > XM subscription.

94 Audio

Information accurate as of January 28th, 2019. Go to <https://serviceinfo.harley-davidson.com> to check for the latest version.

2. **Select:** Radio. See Figure 59. The Radio Services subscription status is displayed with an ESN number and SiriusXM phone number for assistance or activation.
3. **Select:** Specialty Services. See Figure 60. The subscription status for each service (traffic, fuel, weather and forecast services) is displayed with an ESN number and SiriusXM phone number for assistance or activation.

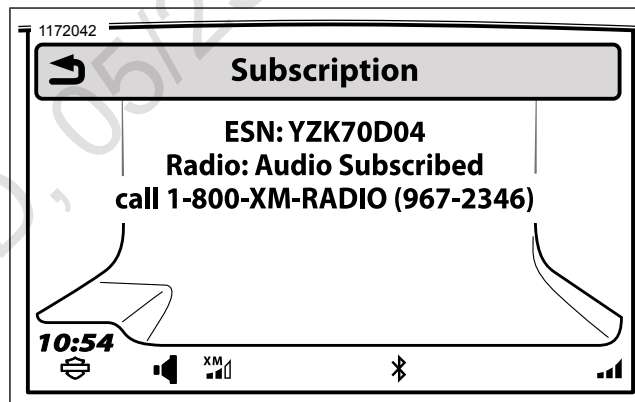

Figure 59. Radio Service Subscription Screen

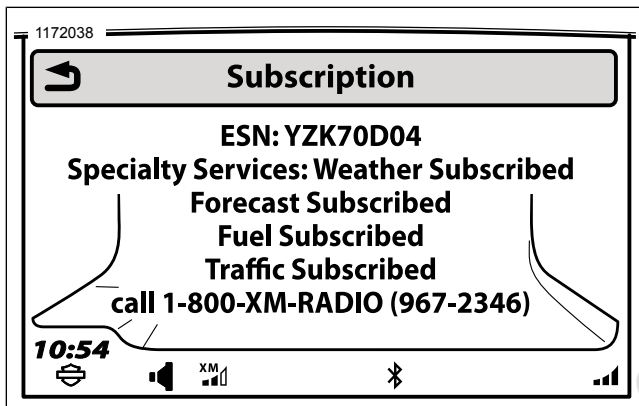

Figure 60. Specialty Services Subscription Information

Subscribing to SiriusXM

1. See Figure 60. Get ESN number for radio.
2. Verify that the SiriusXM signal is being received. Check the SiriusXM Signal Strength icon in the status bar. Channel 1 (preview channel) should be playing audio. SiriusXM starts up with a preview channel (channel 1) until subscription is active.

3. **Subscribe:**

- a. See Figure 60. **By Phone:** Phone number will be displayed after selecting SiriusXM in the Band screen or call the phone number on the ESN screen.
- b. **By Internet:** Go to www.siriusxm.com. Click the subscription link.

4. Keep the radio turned on until the subscription process is complete. Activation may take up to an hour. Since the vehicle will automatically turn off after 20 minutes in accessory mode, it may be necessary to start up and ride the motorcycle.

Listening to SiriusXM Radio

SiriusXM features take a few moments to be displayed after the motorcycle is first started.

1. **Navigate:** Home > Audio.
2. **Select:** Source field.
3. **Select:** SiriusXM.

SiriusXM Presets

Channel presets can be programmed to quickly access favorite channels. The radio up to 20 SiriusXM presets.

1. **Navigate:** Home > Audio.
2. **Select:** Source field.
3. **Select:** SiriusXM.
4. Select a channel.
5. Press and hold a preset until the system beeps.

Selecting a Channel: Hand Controls

Press the Previous/Next switch on the left hand control to change the channel.

Selecting a Channel: Channel List

1. **Navigate:** Home > Audio.
2. **Select:** Source field.
3. **Select:** SiriusXM.

4. **Select:** SiriusXM Channels.
5. Select a desired category from the list.

Selecting a Channel: Direct Tune

1. **Navigate:** Home > Audio.
2. **Select:** Source field.
3. **Select:** SiriusXM.
4. **Select:** Menu.
5. **Select:** Direct tune.
6. See Figure 61. Use the keypad (3) to enter a channel number (2).
7. Select Tune (4) to change to the selected channel.

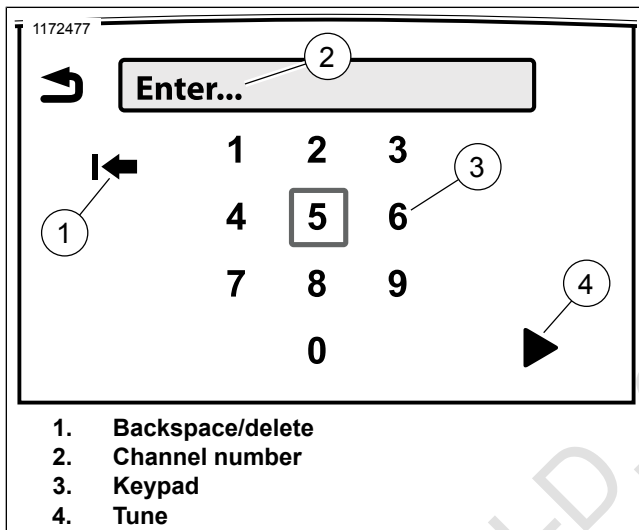

Figure 61. Direct Tune

Selecting a Channel: Voice Recognition

See Voice Recognition (Page 179) for more commands and instructions.

- Select:** Voice recognition switch.

- Speak one of the following commands into the microphone:
 - To listen to SiriusXM radio:** SiriusXM
 - To select a channel:** Channel (followed by the channel name or number)
 - To select next channel up:** Channel Up
 - To select next channel down:** Channel Down
 - To scan channels:** Channel Scan

Scanning SiriusXM Channels

- Navigate:** Home > Audio.
- Select:** Source field.
- Select:** SiriusXM.
- Select:** Menu.
- Select:** Scan. The radio advances through each channel, dwelling for five seconds on each channel.

6. Press the Cursor/Select hand control switch to select a channel.

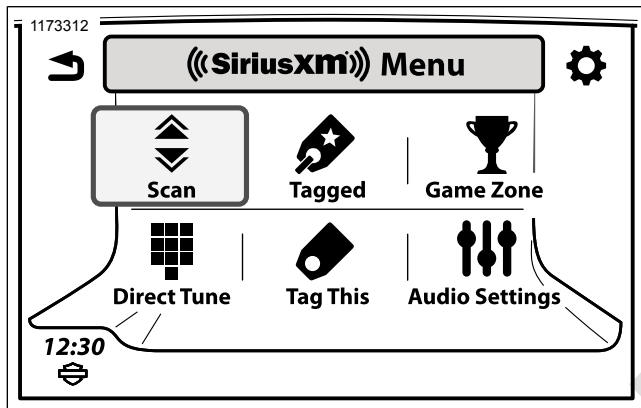

Figure 62. SiriusXM Menu Screen

Tagging an Artist or Song

Tagging allows you to be alerted when a tagged artist or song is playing on any SiriusXM channel. Up to 20 songs or artist tags can be saved.

1. **Navigate:** Home > Audio.
2. **Select:** Source field.

3. **Select:** SiriusXM.
4. **Select:** Menu.
5. **Select:** Tag This.

NOTE

- To tag both song and artist, repeat steps for remaining choice.
6. See Figure 63. The system prompts to tag the song or artist. Once tagged, the system confirms your selection.

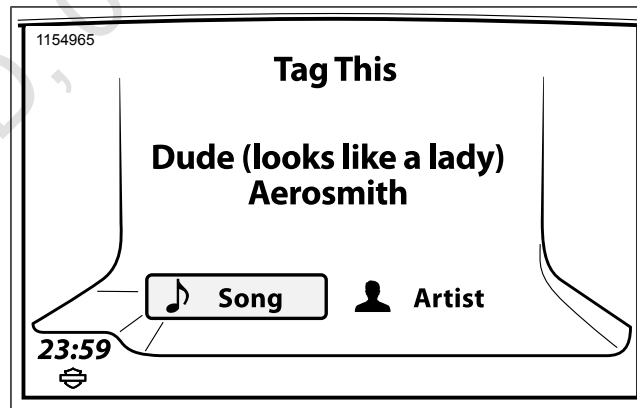

Figure 63. Tagging Screen

Viewing Tagged List

1. **Navigate:** Home > Audio.
2. **Select:** Source field.
3. **Select:** SiriusXM.
4. **Select:** Menu.
5. **Select:** Tagged.
6. See Figure 64. To turn off alerts for a particular song or artist, uncheck the item in the list. To resume alerts, check the item again.

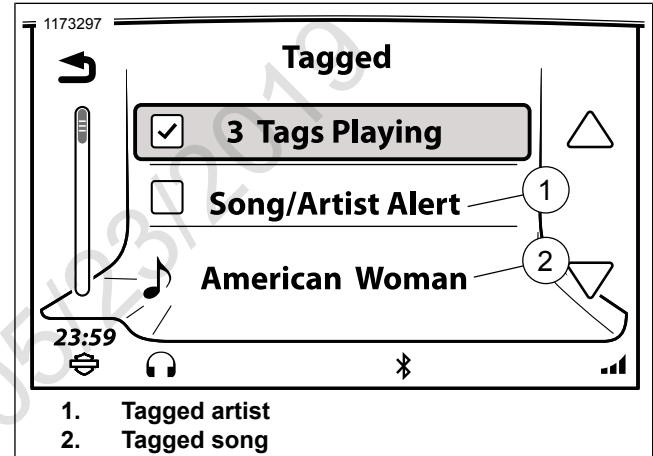

Figure 64. Tagged List

Tag Alert

An alert pops up when a tagged song or artist plays on any channel. Select Listen or Ignore.

Listen: Changes to the channel with the tagged song or artist playing.

Ignore: Remains on the current channel.

SiriusXM Categories

The radio can be configured to scan for particular types of programming (such as news, sports or classical music). When scanning, the radio only stops on stations with the selected categories. The channel list includes only stations with the selected categories.

1. **Navigate:** Home > Audio.
2. **Select:** Source field.
3. **Select:** SiriusXM channels.
4. **Select:** Station categories.
5. See Figure 65. Select desired categories from the list.

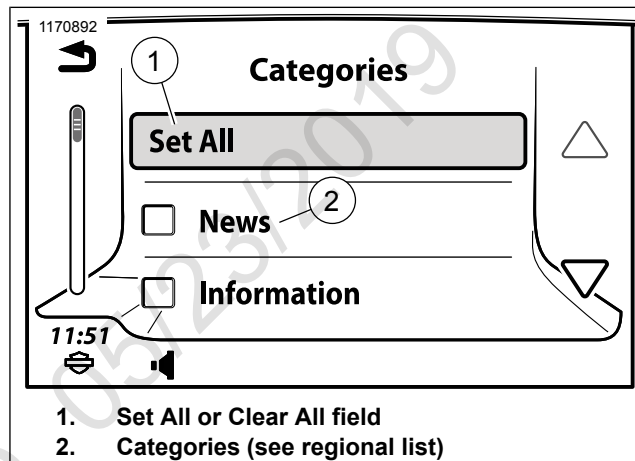

Figure 65. Categories Screen

Game Zone

Game Zone can be set up to trigger an alert when games are broadcasting or score changes occur for your favorite teams. The alerts provide an opportunity to tune to the channel and listen to the game.

Enabling Sports Alerts

Sports Alerts must be enabled before the radio provides game or score notifications.

If Sports Alerts is disabled, all the game and score settings configured for your favorite teams are still retained. However, the system will not provide notifications until Sports Alerts is enabled again.

1. **Navigate:** Home > Audio.
2. **Select:** Source field.
3. **Select:** SiriusXM.
4. **Select:** Menu.
5. **Select:** Game zone.
6. See Figure 66. Check the Sports Alerts checkbox. Game and score alerts that have been set for any favorite teams will be displayed as they occur.

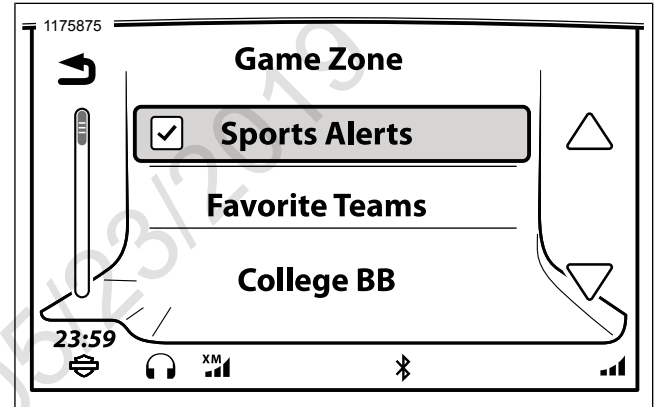

Figure 66. Sports Alerts

Adding a Game Zone Favorite

Up to seven teams can be added as Game Zone favorites.

1. **Navigate:** Home > Audio.
2. **Select:** Source field.
3. **Select:** SiriusXM.
4. **Select:** Menu.

5. **Select:** Game zone.
6. Select the type of team (MLB, NBA and so on). A list of teams within the selected league are shown.
7. Select a team from the list.

NOTE

Selecting Game or Score checkbox will Automatically add team to favorites.

8. See Figure 67. **Select:** Add to Favorites. Game and Score will automatically be selected.



Figure 67. Game Zone Favorites

Setting Game or Score Notification

1. See Adding a Game Zone Favorite.
2. **Game notification:** To display an alert whenever a game is being broadcast for this team, select the game checkbox.
3. **Score notification:** To display an alert whenever a score changes in a game for this team, select the score checkbox.

Responding To Game Zone Alert

Depending on the settings, a game zone alert pops up when a game is being broadcast or a score change has taken place for a favorite team.

1. **Listen:** The radio tunes to the channel that is broadcasting the game.
2. **Ignore:** The radio continues with its current audio source.

Removing a Game Zone Favorite

1. **Navigate:** Home > Audio.
2. **Select:** Source field.
3. **Select:** SiriusXM.
4. **Select:** Menu.
5. **Select:** Game zone.
6. **Select:** Sports alert.
7. **Select:** Favorite teams.

8. Select team to be removed from the list.
9. **Select:** Clear from Favorites. The team is removed from game zone favorites list.

Displaying Weather

1. **Navigate:** Home > Navigation.
2. **Select:** Menu.
3. **Select:** Weather.
4. **Select:** Forecast. See Figure 68.
5. **Select:** Current location or Other location.
 - a. **Current location:** Displays weather conditions for current location.
 - b. **Other location:** Select state and location to view.

6. **Select:** Current, Daily or 5 Day.

- a. **Current:** The screen displays current weather conditions. Selecting **Details** on the screen will give a detailed outlook of weather conditions. See Figure 69.
- b. **Daily:** The screen shows forecasted weather conditions in 3 and 6 hours. See Figure 70.
- c. **5 Day:** The screen shows forecasted weather conditions for today and tomorrow. Use scroll or swipe for next five days of weather data. See Figure 71.

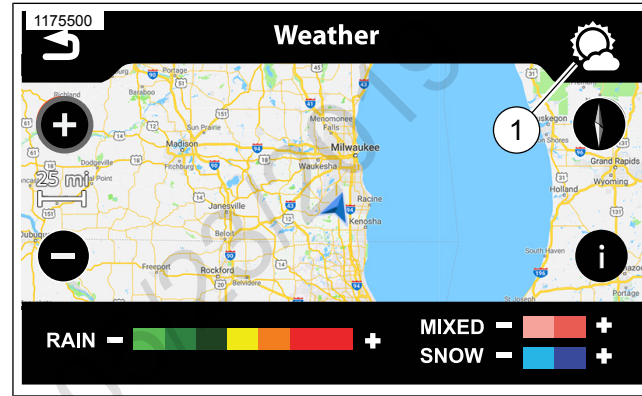

Figure 68. Weather Forecast Icon

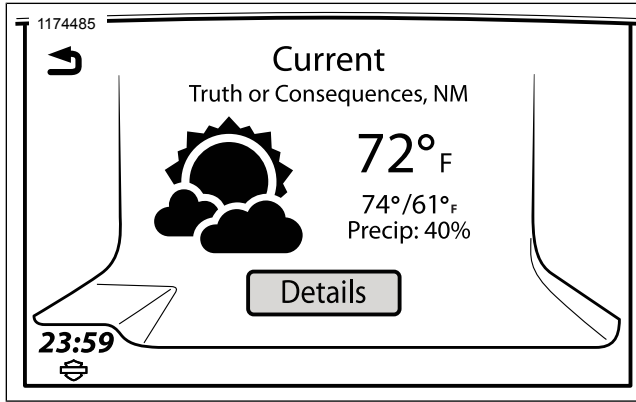

Figure 69. Current Weather

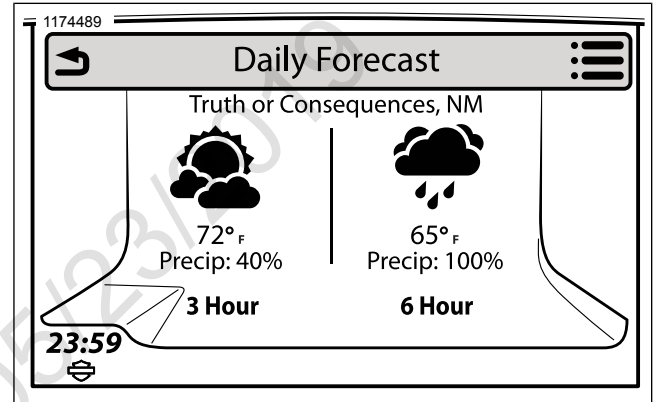

Figure 70. Daily Weather Forecast

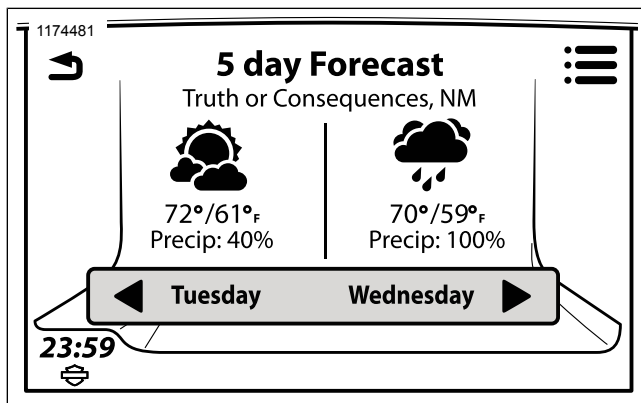

Figure 71. 5 Day Weather Forecast

SiriusXM Weather Map

See Figure 72. SiriusXM weather displays a map with radar and weather front information. The map is displayed in north up orientation and is typically updated every 12 minutes. The weather map displays major roadways, but it is not designed as a tool for navigation.

1. **Navigate:** Home > Navigation.
2. **Select:** Menu.

3. **Select:** Weather. The radio displays a large-scale map with the current location of the vehicle.
4. Select settings on the Nav Menu screen to configure the display of the map.

Weather Map Scrolling

See Map (Page 139).

1. With the weather map displayed, press a location on the touchscreen or press and hold the Cursor/Select on the hand control switch.
2. Scroll or swipe to change the displayed location of the map. Use the zoom controls to zoom in or out.

Weather Map Radar and Fronts

See Figure 72. The radar displays patterns of precipitation on the map. The intensity of rain, snow or mixed precipitation is indicated by the legend on the bottom of the map. The map can also display weather fronts, atmospheric pressure and isobars.

1. While in the weather map, select the information icon on the right side of the screen.

2. **Turn on radar:** Check the **Radar** checkbox.
3. **Turn on weather fronts:** Check the **Fronts** checkbox.
4. **Select:** Back. Radar formations and weather fronts are displayed on the map.

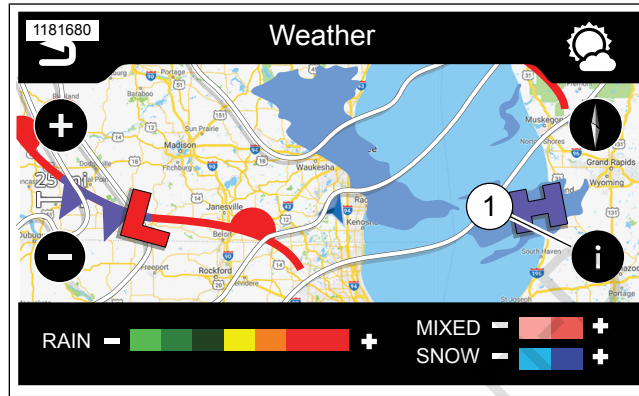

Figure 72. Weather Information

Table 35. Radar Information

PRECIPITATION TYPE	INTENSITY
Rain	Seven color levels ranging from light rainfall (light green) to severe (red)
Snow	Light snowfall (light blue), heavy snowfall (dark blue)
Mixed	Light mixed precipitation (light pink), heavy mixed (dark pink)

Table 36. Weather Front Information

INDICATOR	DESCRIPTION
Cold front	Shown as a blue line with triangles. Displays the leading edge of a cold air mass. The triangles show the forward direction of the front.
High pressure (H)	Shows center of high atmospheric pressure.
Isobar	Thin line which indicates equal or constant atmospheric pressure.
Low pressure (L)	Shows center of low atmospheric pressure.

Table 36. Weather Front Information

INDICATOR	DESCRIPTION
Stationary front	Shown as an alternating red-blue line with triangles and semi-circles. Displays a boundary between warm and cold air masses.
Warm front	Shown as a red line with red semi-circles. Displays the leading edge of a warm air mass. The semi-circles show the forward direction of the front.

Display Last Weather Update

1. With the weather map displayed, select the option icon on the right side of the screen.
2. **Select:** Update Information. The radio shows the date and time for the last update to the radar and weather front information.

SiriusXM Fuel Prices

The fuel feature provides the fuel prices at stations within a specified distance of the motorcycle. This feature can be used to route to a selected station, or add stations to an existing route.

Selecting Fuel Type

The screen shows locations and prices according to fuel type that is selected (regular, medium, premium or diesel).

NOTE

Use only unleaded gasoline with fuel type and octane specified for your motorcycle. Do not use diesel or other inappropriate fuels for the motorcycle. See vehicle owner's manual. Using wrong type of fuel can damage the engine, fuel system and other components.

1. **Navigate:** Home > Navigation.
2. **Select:** Menu.
3. **Select:** Fuel prices.
4. **Select:** Fuel type.
5. After selecting fuel type, select **Back** on right hand control to return to fuel prices.

Viewing Fuel Prices

Fuel prices are shown per gallon or liter, depending on the English/Metric setting.

1. **Navigate:** Home > Navigation.
2. **Select:** Menu.
3. **Select:** Fuel prices.
4. **Select:** View prices. A list of up to 30 nearest stations within 100 miles are displayed. Stations are listed by distance from current location.
5. See Figure 73. **Select:** Sort by distance/brand/price icon (2). This will sort the list by brand (station name), fuel price or distance to the station.
6. Select a station from the list.

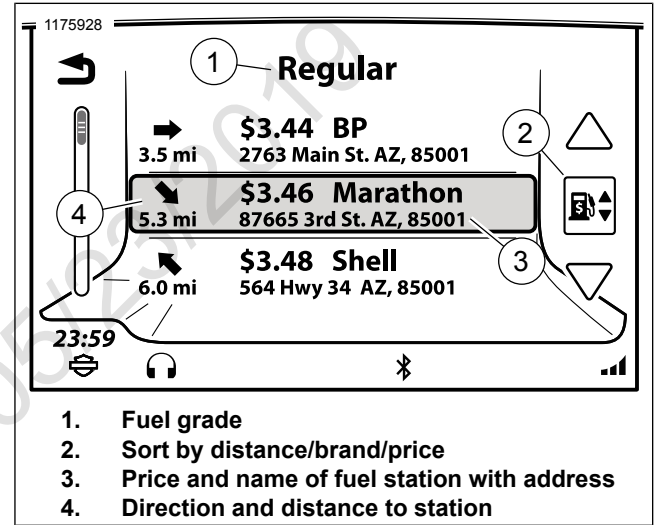

Figure 73. Fuel Prices

7. See Figure 74. Options for the station are displayed.
 - a. **Fuel Station:** The company brand name or brand of fuel is displayed.

- b. **Route/View:** Selecting **Options** lets you select desired route. Selecting **Save** lets you save it to a list or save it as home. Selecting **Go** calculates and takes you to selected gas station.
- c. **Call:** With phone connected, the phone dials the gas station (to confirm prices, check operating hours and so on).
- d. **Fuel Prices:** Displays the price for all fuel types and a date stamp.

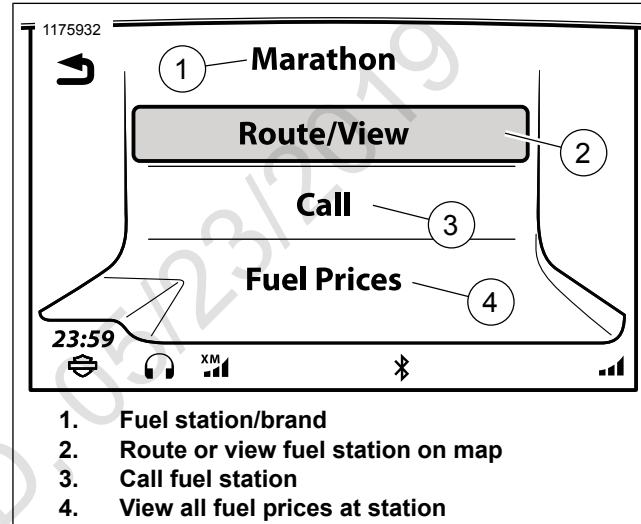

Figure 74. Gas Station Selected

SiriusXM Traffic

Displays a list of messages regarding traffic, construction, accidents or other events nearby that may impact your chosen route. The system can be configured to provide popups of traffic events, and provide new routes to avoid traffic obstructions.

Turning Traffic On

When using the traffic feature, the system will automatically prompt to turn on traffic if necessary. Traffic can also be enabled in the system settings. See Traffic (Page 164).

Traffic Notification Popups

The system can be configured to automatically display traffic alerts that affect the current navigation route. The system will only display the notification when a route is active and an alternative route would reduce the current ride time by five minutes or more.

See Traffic (Page 164).

Traffic Icons

Navigate: Home > Setup > Traffic > Legend. A description of all traffic icons are displayed in the Setup menu.

Also see Traffic (Page 164).

Traffic Reroute

See Traffic (Page 164).

Traffic Message List

1. **Navigate:** Home > Navigation.

2. **Select:** Menu.

3. **Select:** (SiriusXM) Traffic.

4. If prompted to turn on traffic, select **Yes**.

5. See Figure 75. A list of nearby traffic events (1) is displayed. Each item displays the direction and distance to the traffic event. Road signs and traffic icons are also displayed.

a. To toggle between all nearby events or only events along the route, select the switch-view icon (2).

6. Select traffic event (1) from list. This displays a detailed traffic message.

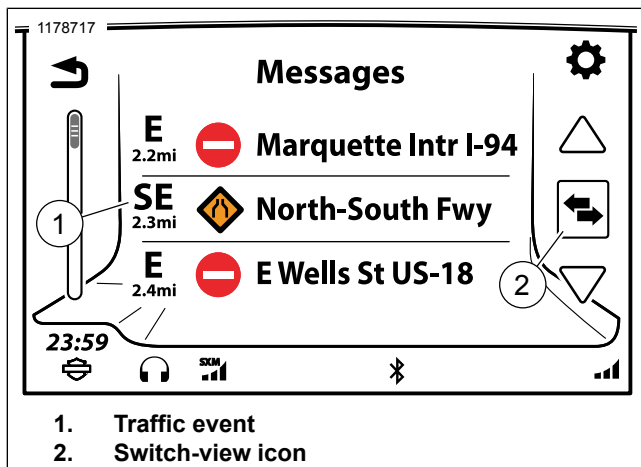

Figure 75. Traffic Message List

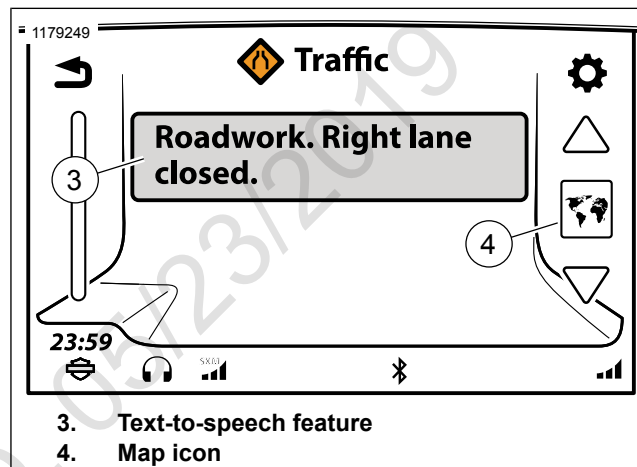

Figure 76. Traffic Message

7. See Figure 76. **Select:** Traffic event. The radio reads the text message over the speakers or headset by using the text-to-speech feature. While riding, the scroll feature for the message is locked out.
8. Select the map icon (4) to display the incident location on the map.

BLUETOOTH

Enabling Bluetooth

NOTE

Bluetooth must be enabled before pairing or connecting with Bluetooth devices.

1. **Navigate:** Home > Setup.
2. **Select:** Bluetooth Setup.

3. See Figure 77. **Select:** Bluetooth to enable. A checkmark appears in the box.

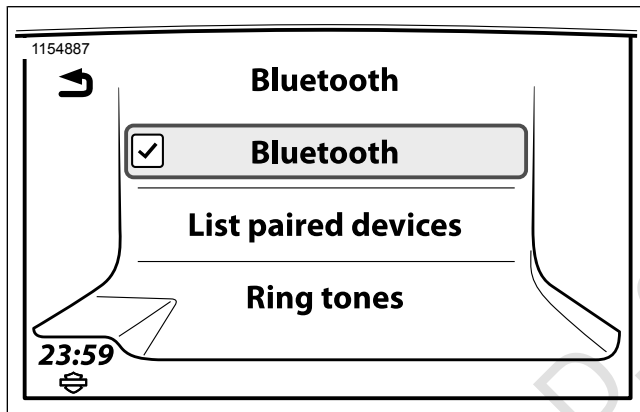

Figure 77. Bluetooth Setup Menu

Pairing a Bluetooth Device

A maximum of six devices can be paired with the radio at one time. However, the radio only maintains an active Bluetooth connection with up to one device for phone service and one device for media at a time.

The motorcycle identifies itself as "Boom! Box GTS". The name for the Bluetooth device is specified within the settings for your device.

NOTE

Phones may request permission to share information with "Boom! Box GTS" (such as phone book contacts and text messages). These requests may occur during the pairing process or on other occasions when the phone is connecting with the radio.

1. In the Bluetooth-compatible device, enable Bluetooth and set the device as discoverable. See the manual for your device.
2. **Navigate:** Home > Setup.
3. **Select:** Bluetooth setup.
4. **Select:** List paired devices.
5. **Select:** Add a new device. All discoverable devices within range appear in the list of found devices.
6. Select device to be paired.
7. The device displays a PIN code (auto-generated) and prompts for permission to pair with the "Boom! Box GTS". Allow pairing with the device.

8. **Select:** Yes. The radio attempts to pair and connect with the device.
9. The system prompts for an emergency phone number if one is not already stored in the system. Enter a phone number to call in the event of an emergency (such as 911 in the US).
10. **Select:** Save. Located in lower right corner of the screen.
11. The system begins downloading the phone book from the device. The Phone Book icon is displayed in the status bar during the download process. During this process, the phone may prompt for permission to share the phone book.

Listening to Music

NOTE

Some Bluetooth devices cannot be controlled through the radio.

1. See Figure 78. **Navigate:** Home > Audio.
2. **Select:** Source Field.
3. A connected device is displayed with Bluetooth symbol.

114 Audio

Information accurate as of January 28th, 2019. Go to <https://serviceinfo.harley-davidson.com> to check for the latest version.

4. Select device.
5. See Figure 79. When connected, selected song from device begins playing.

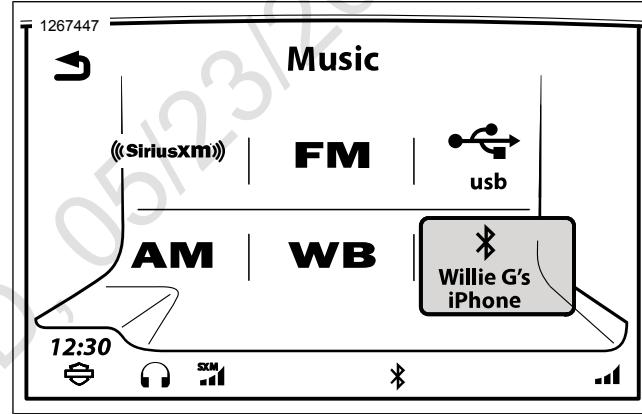

Figure 78. Select Bluetooth Phone

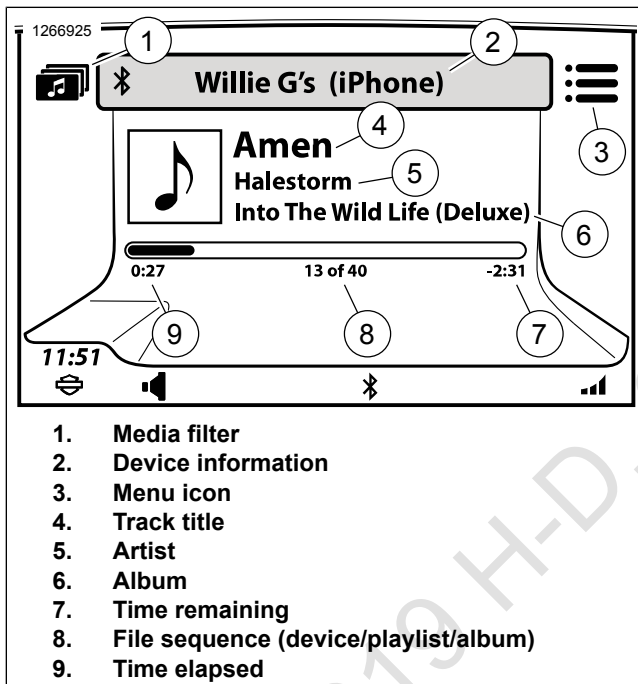

Figure 79. Playing Music from Phone

Connecting/Disconnecting a Bluetooth Device

A Bluetooth device can be connected for phone service, media or both. The system only allows one device to be connected for each Bluetooth service (phone or music).

The radio will automatically try to connect with the phone or media device after pairing. For some devices, a setting is required within the device before it will automatically connect. See the manual for the device.

To manually connect or disconnect with a Bluetooth device after pairing, use the following procedure.

1. **Navigate:** Home > Setup.
2. **Select:** Bluetooth setup.
3. **Select:** List Paired Devices. A device with a highlighted phone icon is connected for phone service. A device with a highlighted media icon is connected for media.
4. Select a device from the list to connect or disconnect.
 - a. Select icon to connect or disconnect phone service.
 - b. Select icon to connect or disconnect music.

Reconnecting After Vehicle Turns On

When the motorcycle is turned on, the radio will automatically try to establish a Bluetooth connection with the phone from the last vehicle shutdown.

Allow a few moments for the radio to initialize and the phone connection to complete. The status bar displays the Bluetooth icon when the phone is connected.

The radio will not automatically reconnect with media devices over Bluetooth. Manually reconnect the phone and other media devices as necessary.

Deleting a Paired Device

A device will typically remain paired with the radio until deleted.

1. **Navigate:** Home > Setup.
2. **Select:** Bluetooth setup.
3. **Select:** List paired devices.
4. Select the device from the list.
5. **Select:** Delete pairing.

6. **Select:** OK to confirm.

AUDIO SYSTEM CARE

Use only Harley-Davidson recommended products and methods to keep the radio, speakers and other audio system components clean and in good condition. Do not use any abrasives, polishes or rubbing compounds to clean the screen or other components. Do not use any ammonia-based cleaners on the screen. Use of other products or methods may cause damage to components.

Screen

NOTE

Do not use any chemical cleaners or chemical containing wipes or cloths. These can cause damage to the screen surface.

Gently clean the display glass surface with a clean, dry microfiber cloth. Prior to cleaning it is suggested to remove any deposits of visible dust, dirt, sand particles with a gentle stream of compressed air. Cleaning the display glass in the presence of above can create scratches.

Cleaning the Radio

Spray a light amount of HARLEY GLOSS on a MICROFIBER DETAILING CLOTH. Be careful to gently remove any sediments without rubbing them into the screen. Apply circular motions from the center and outwards. Use a dry

MICROFIBER DETAILING CLOTH to dry the screen. Repeat the process as necessary.

NOTE

Do not use any screen enhancing chemicals or products. These can damage the screen surface.

Speaker Care

If a haze develops on speakers with a protective grille, use HARLEY SEAT, SADDLEBAG, AND TRIM CLEANER and a SOFTCLOTH or SOFT DETAILING PAD to clean. Do not apply wax or any other similar products on speaker grilles.

Do not use compressed or forced air on speakers.

Vehicles with saddlebag speakers are designed to prevent water intrusion and to allow water to drain during washing or riding in all weather. To remove any standing water from saddlebag speakers, open the saddlebags and gently shake any remaining water from the speakers.

NOTES

© 2019 H-D, 05/23/2019

PHONE COMPATIBILITY

Some phones may not be compatible with all the features and services in the radio. See the phone compatibility information at www.Harley-Davidson.com. Some features may vary by region or carrier.

At a minimum, the phone must support the Bluetooth profiles shown in Table 37 to be compatible with various features in the radio. Even with these basic requirements, the phone may not necessarily be compatible with all features.

Table 37. Required Bluetooth Profiles

PROFILE	DESCRIPTION
A2DP/AVRCP Profile (AV/Music)	Connect media, media controls, metadata
Hands-Free Calling Profile (HFP)	Pairing, connecting, call features, battery indicator, signal strength indicator
HFP+PBAP+AV Profile	Calls and connection
Message Access Profile (MAP)	SMS text message features
Phonebook Access Profile (PBAP)	Phonebook download, call history download

BLUETOOTH AND USB CONNECTIONS FOR PHONES

Phone services are only achieved through a Bluetooth connection. Connecting a phone to the USB port allows the phone to charge and may provide additional media features. However, a USB connection alone will not operate the phone features.

The phone must be paired and connected through Bluetooth before operation. See Bluetooth (Page 112).

PHONE MENU

1. See Figure 80. **Navigate:** Home > Phone.
2. Select one of the phone features.

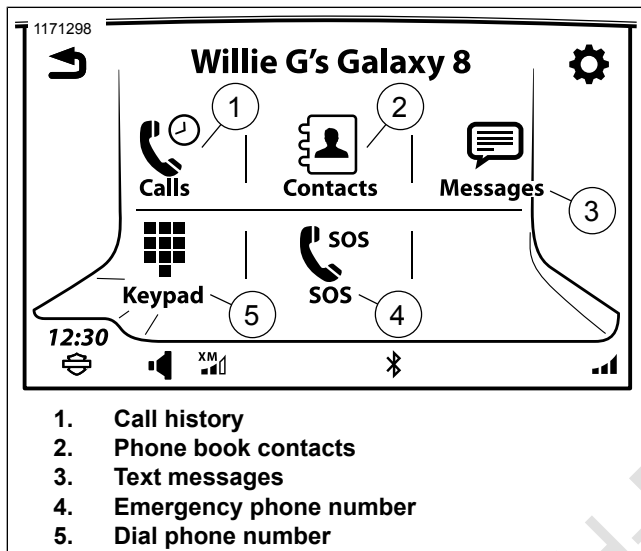

Figure 80. Phone Menu

CALL SCREEN

See Figure 81. When a call is initiated or accepted, the Call screen is displayed. This screen shows information for the current call.

While in an active phone call, you can change to other screens and use other features (such as navigation). However, other

audio sources remain muted, paused or inaccessible until the phone call is finished.

Return to the Call screen to end the call or use other phone features. To return to the Call screen at any time during a call, press the Home switch twice.

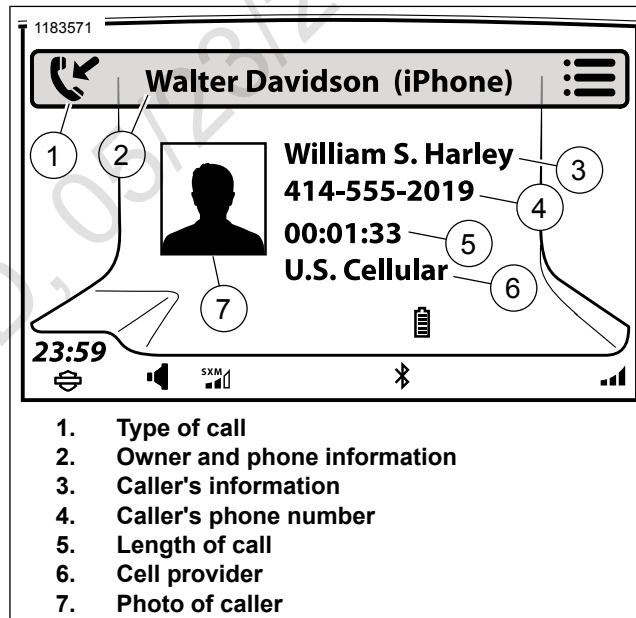

Figure 81. Call Screen

IPHONE: USING SIRI

NOTE

Siri is unavailable while in a phone call or Voice Recognition session.

After pairing the iPhone, the touchscreen will display two instructions confirming operation of the voice command switch.

1. See Figure 82. Press and hold voice command until **Siri** displays on the touchscreen.

NOTE

Placing a phone call through Siri will place a hands-free phone call with the status displayed on the head-unit.

2. **Siri** replies **How may I help you?**
 - a. Speak your command.
3. Press voice command to disconnect Siri.

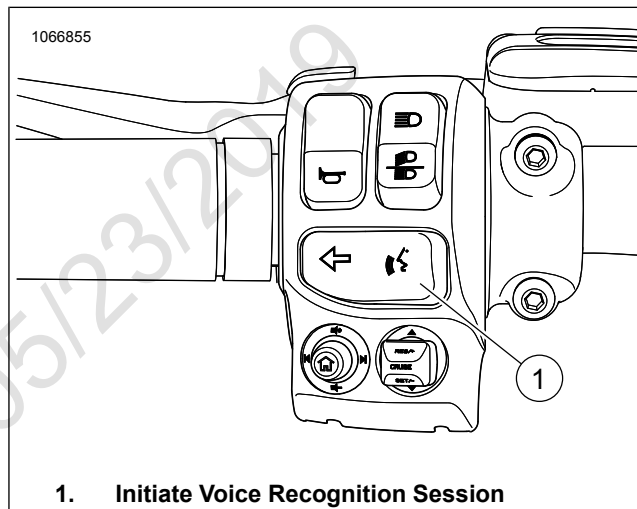

1. **Initiate Voice Recognition Session**

Figure 82. Voice Command Switch

MAKING A CALL

Dialing

1. **Navigate:** Home > Phone.
2. **Select:** Keypad.

3. See Figure 83. Type phone number using keypad. Use backspace/delete or other characters as needed.

- a. **Select:** Save. To add phone number to Saved list.
- b. **Select:** Dial. To call dialed number.

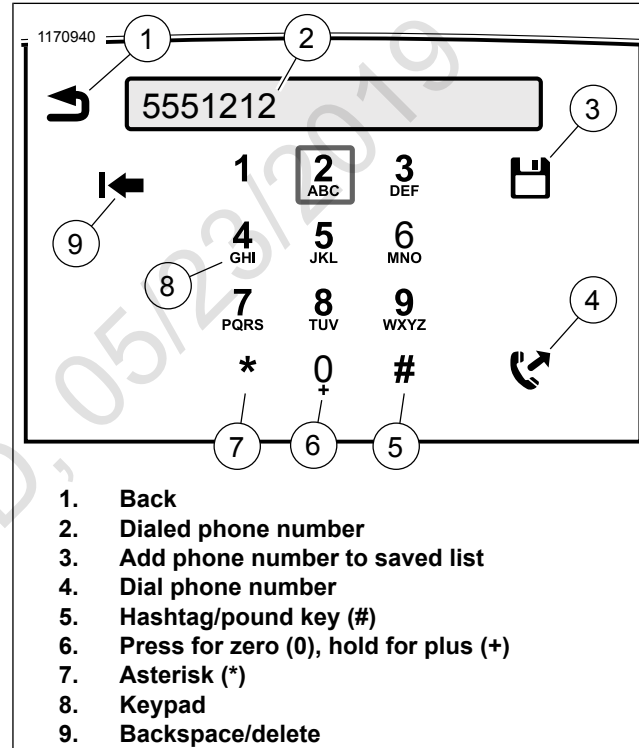

Figure 83. Phone Keypad

Phone Book Contact

1. **Navigate:** Home > Phone > Contacts.
2. **Select:** Contacts on Phone.
3. Select the contact name from the list. The letter jump feature can be used by pressing the center icon in the scroll controls.
4. Select the desired phone number.

Navigation POI

1. **Navigate:** Home > Navigation.
2. **Select:** Search > POI.

NOTE

Use settings icon to define search area to either **Near Me** or **Along Route**.

3. **Select:** Category.
 - a. Scan through subcategories to desired location.
4. Make selection and Call.

SiriusXM Gas Station

1. **Navigate:** Home > Navigation.
2. **Select:** Settings > Fuel Prices.
3. **Select:** Fuel Type first then back out to View Prices.
4. Make selection and call.

Emergency Phone Number

1. **Navigate:** Home > Phone.
2. **Select:** SOS.
3. **Select:** Dial.

Dialing with Voice Recognition

See Voice Recognition (Page 179) for more voice recognition instructions.

1. **Select:** Voice Recognition (left-hand control).
2. **Speak:** Dial.

3. **Speak:** Phone number.

Calling a Contact with Voice Recognition

1. **Select:** Voice Recognition (left-hand control).
2. **Speak:** Call.

NOTE

Name must be in the device's phone book or saved list.

3. **Speak:** Name.

RECEIVING A CALL

Accepting/Ignoring

When a call is received, the radio plays the ring tone and displays the incoming call information as shown in Figure 84. The call can either be accepted or ignored. Other audio sources are muted until the phone call ends.

Accepting the call: Select **Accept**. The call screen is displayed and the call begins.

Declining the call: Select **Ignore**. The phone declines the call and sends it to voicemail (or other function as determined by the phone manufacturer or carrier). The previous audio

source resumes. See Phone Book (Page 126) to display a list of missed calls.



Figure 84. Incoming Call

Radio Turned Off

Phone calls can be received while the radio is turned off. When a call is received, the radio displays the call information and plays the ring tone. If the call is accepted, the phone features operate normally. The radio turns off when the call ends.

CALL OPTIONS

Ending a Call

Selecting End Icon: The call terminates. The caller can be added to the saved list by selecting Save.

Making a New Call: Initiating a new call will terminate the current call.

Accepting a New Call: Accepting a new call will terminate the current call.

Adjusting Call Volume

During a call, use the volume hand control switch to adjust the incoming call audio. The passenger can use the volume controls on the Tour-Pak to adjust volume in the passenger headset.

Muting Call Audio

Muting Microphones: While in a call, select the Menu icon. Select the Mute/Unmute icon until Mute is displayed. The call screen displays a Mute icon in the lower right corner. Audio from the rider and passenger microphones will not be sent over the phone.

Unmuting Microphones: Press the Mute/Unmute icon until Unmute is displayed. The Mute icon is removed and the microphones resume normally.

Muting Inbound Audio: Use the volume hand control switch to adjust incoming audio to minimum volume. The POWER/MUTE button does not mute incoming phone audio.

Routing Call Audio

Outbound call audio is always spoken into the rider and passenger microphones. However, the inbound call audio can be received through either the speakers or headsets. See Speaker (Page 65).

Multiple Calls

The radio only allows one active phone call at a time. When choosing to initiate or accept a new call, the other existing phone call is dropped.

New Incoming Call (while call is in progress): The system will prompt to either accept or ignore the new incoming call. If the new call is accepted, the existing call is dropped. If the new call is ignored, the current call continues.

Starting New Call (while call is in progress): Using the keypad, contacts list or emergency phone number, initiate the new call. When prompted, decide whether to continue

with the existing call, or to start the new call (terminating the current call).

VOICE MAIL

The radio does not indicate voicemail status. For most phone carriers, voice mail can be accessed by dialing the phone number for the mobile phone that you are using.

If a dial tone passcode is required to access voice mail, press the Voice Recognition switch during the call. Speak the passcode numbers and other special characters as needed. For example, to enter a passcode as "1234#", speak **ONE-TWO-THREE-FOUR-POUND** into the microphone.

PHONE BOOK

Phone Book

Contacts in a device's phone book can be used to initiate calls, display incoming caller information and navigate to a contact address. While multiple phone books can be stored in the radio from different paired phones, only the phone book from the currently connected phone is made available for use.

See Figure 85. The phone book displays entries for home, mobile, work or other phone numbers, according to the entries in the connected phone. If a contact does not have a phone number stored, the contact will not be displayed in the list.

When a paired phone is removed, the phone book is deleted. Pairing the phone again requires the phone book to be downloaded.

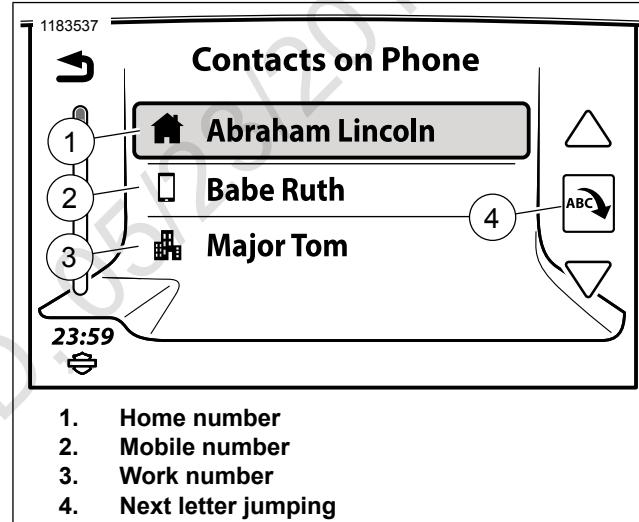

Figure 85. Phone Book

Setting Up Contacts in a Phone

Consider setting up contacts such as **Emergency**, **Work**, **Voicemail**, **HOG** and **Dealer** in the phone. Use simple names so it is easy to pronounce with the voice recognition

commands. Include as much information as possible, such as alternate phone numbers and address information. With these items properly set up in the phone book, it becomes much easier to use voice recognition and say **Call Work** or to use phone book entries to route to a destination.

Refresh Phone Book

The radio first downloads the phone book during initial pairing, and typically synchronizes with the connected phone when the vehicle is turned on. The phone book can be manually refreshed from the connected phone at any time.

1. **Navigate:** Home > Phone > Contacts.
2. **Select:** Sync Phone Contacts

The system begins downloading the current phone book from the device. During the download process, the phone may prompt for permission to share the phone book. Allow the phone book to be downloaded.

Showing Contact Details

The name, phone numbers and address for the contact are displayed (if populated) as shown in Figure 86. Selecting address begins navigation to that destination.

1. **Navigate:** Home > Phone > Contacts.

2. **Select:** Contacts on Phone.
3. Select contact from list.

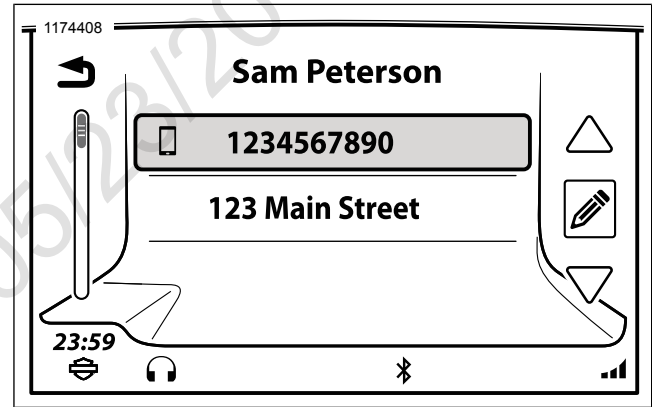

Figure 86. Contact Details

Viewing Saved Contacts and Phone Numbers

1. **Navigate:** Home > Phone > Contacts.
2. **Select:** Contacts on Radio.
3. Select contact from list.

4. Select phone number to begin call or select address to route navigation to address.

Saving a Phone Book Contact

1. **Navigate:** Home > Phone > Contacts.
2. **Select:** Contacts on Phone.
3. Select contact from list.
4. **Select:** Save Contact on Radio.

Saving a Dialed Phone Number

1. **Navigate:** Home > Phone > Keypad.
2. Enter phone number.
3. **Select:** Save.

Saving Phone Number from Current Call

When a call is finished, the **Save** icon is briefly displayed. Select **Save** to store phone number to saved list.

Delete Saved Contact

1. **Navigate:** Home > Phone > Contacts.
2. **Select:** Contacts on Phone.
3. Select contact from list.
4. **Select:** Edit (pencil).
5. **Select:** Delete.
6. **Select:** Yes to confirm.

Call History

1. **Navigate:** Home > Phone > Calls.
2. A list of **All Call** activity for phone is displayed. The radio can display up to 60 total calls (20 missed, 20 received and 20 dialed calls).
3. To display only the missed, received or dialed calls, repeatedly select the icon in the upper right corner.

TEXT MESSAGING

The radio can be used to read and listen to incoming text messages (using the text-to-speech feature). An auto-reply feature can also be configured. For safety purposes, the radio cannot be used to send text messages. Not all phones are compatible for text messaging features.

Enabling Text Messaging: SMS

1. **Navigate:** Home > Phone > Messages.
2. See Figure 87. **Select:** SMS.

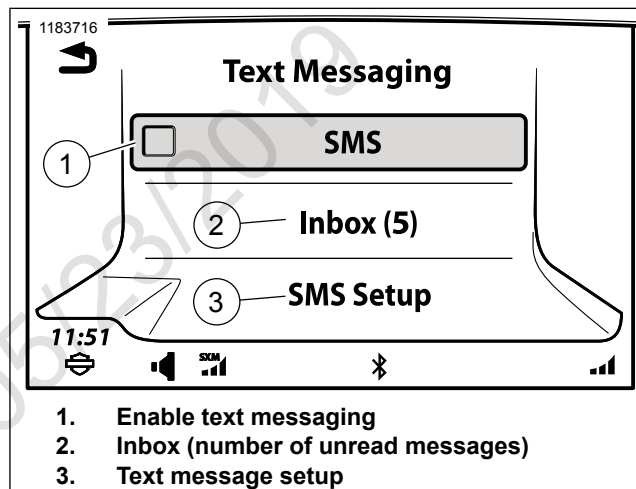

Figure 87. Text Message Menu

Enabling New Message Pop-Up

The radio displays Incoming Message popup screen indicating options: View, Listen, Ignore and Call. Select an icon to acknowledge the message or activate a feature.

1. **Navigate:** Home > Phone > Messages.
2. See Figure 87. **Select:** SMS Setup.

3. **Select:** New Message Popup to enable option.

Text Message (SMS) Auto-reply

The auto-reply feature responds to incoming messages with a heading **Auto Generated Text** along with the contents of the personal message setting.

1. **Navigate:** Home > Phone > Messages.
2. **Select:** SMS Setup.
3. **Select:** Auto-Reply to enable option.
 - a. **Select:** View Reply Message to look at the auto generated text.
 - b. **Select:** Edit Reply Message to compose new auto generated text. OK must be selected for edit to be accepted.

Viewing/Playing A Text Message

When a new message is received, the New Message icon is displayed in the status bar. This icon clears after the text message inbox has been viewed.

Text message viewing is locked out while the motorcycle is in motion. Instead, the text-to-speech feature reads the selected text message through the speakers or headsets.

1. **Navigate:** Home > Phone > Messages > Inbox.

NOTE

*Texts **Will Not** be available to view while vehicle is in motion.*

2. **Select:** Incoming text message to view.
 - a. See Figure 88. **Vehicle Not in Motion:** Text is shown on the vehicle's radio screen.

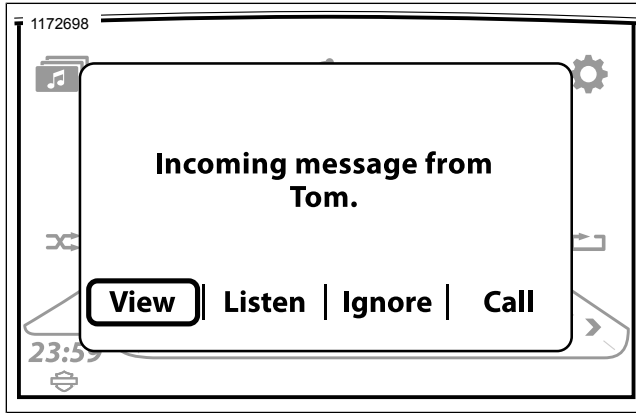

Figure 88. Vehicle Not in Motion



Figure 89. Vehicle in Motion

- b. See Figure 89. **Vehicle in Motion**: Text-to-speech feature is activated. Select **Listen** in the popup.

Enabling Text Message Notification: Apple Devices

Notification settings need to be configured in Apple devices before the radio can receive text messages.

See your Apple owner's manual for proper settings and procedure.

RING TONE

Selecting

The radio has four built-in ring tones available (Rain, Suspense, Rave and Xylo). An additional ring tone can also be loaded into the radio.

1. **Navigate:** Home > Setup > Bluetooth.
2. **Select:** Ring Tones.

NOTE

Loaded Ring Tone is grayed-out if no ring tone has been loaded.

3. Select one of the four default ring tones or loaded ring tone.

Adding New Ring Tone: USB

1. Plug USB device into USB port.
2. **Navigate:** Home > Setup > Bluetooth.
3. **Select:** Load Ring Tones.

4. **Select:** USB device.
5. **Select:** Artist, Song, Album, Genre, Playlist or Filename.
6. Follow the flow of standard media screens down to track list.
7. **Select:** File to load.
8. Ring tone file is confirmed with one of two options:
 - a. New Ring Tone Loaded and Set. Select OK.
 - b. Replace existing ring tone? Select Yes or No.

RESUMING CALLS AFTER VEHICLE SHUTDOWN

If a call is active while the motorcycle is being turned off, the radio will request to transfer the call back to the phone as shown in Figure 90.

Selecting Yes: The call transfers back to the phone. The Bluetooth connection terminates and the radio shuts down.

Selecting No (or not acknowledging the prompt): The radio continues to support the call for approximately five minutes. At the end of this period, the radio attempts to transfer the call back to the phone and the radio shuts down.

NOTE

Phone audio can only continue through the headset during this shutdown period. If the phone audio is routed through the speakers, the call will continue but the incoming audio will not be heard.

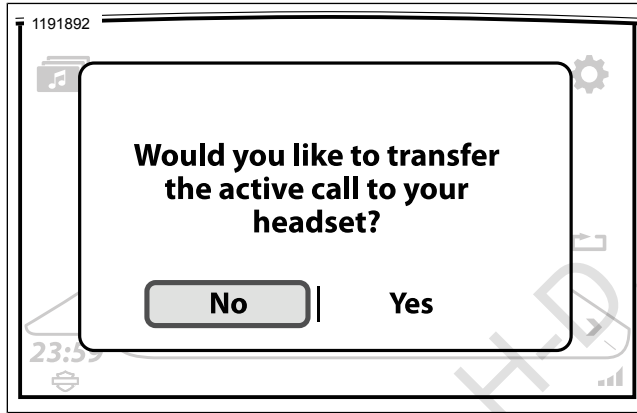

Figure 90. Transfer Phone Call

TRANSFERRING A CALL BACK TO THE PHONE

Only use the phone handset manually while the motorcycle is stopped.

1. **Navigate:** Home > Phone.

2. **Select:** Settings.
3. **Select:** List Paired Devices.
4. Select phone that is actively paired to vehicle.
5. **Select:** Disconnect for Phone. The Bluetooth phone connection terminates and the phone call transfers back to the handset.

CHANGING THE EMERGENCY PHONE NUMBER

When the first phone is paired, the radio prompts for an emergency phone number. One emergency phone number can be stored in the radio. This same phone number is used for any phone connected to the radio.

1. **Navigate:** Home > Phone > SOS.
2. See Figure 91. **Select:**
 - a. Edit # (to change phone number).
 - b. Clear# (to delete phone number).
3. Enter new emergency phone number (e.g. 911).

4. **Select:** Save.

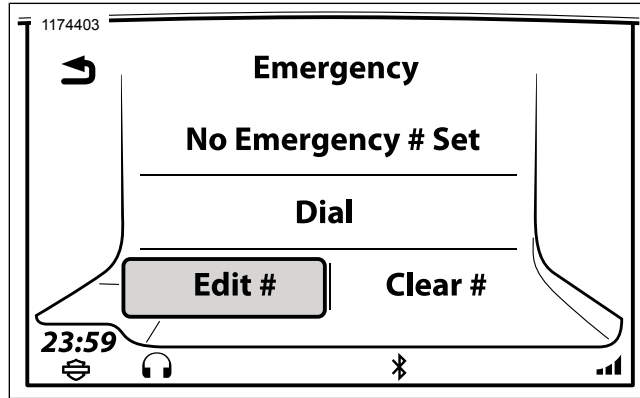

Figure 91. Dialing or Editing Emergency Number

APPLE CARPLAY

During projection mode, the Phone icon on the home screen is replaced with the Apple CarPlay icon. Also, the tuner or media selections are paused, active route is cancelled and projection mode assumes priority. Upon exiting projection mode all items return to normal radio functions.

CarPlay is compatible with iPhone 5 and later models.

NOTE

Apple CarPlay does not require an app download. When connected, **not all** iPhone apps will be displayed on the screen, only Apple approved apps.

The rider requires a headset with microphone to enable voice commands.

1. Switch power to Accessory, Ignition or Run (CVO).
2. Turn projection mode on.
 - a. **Navigate:** Home > Setup.
 - b. **Select:** Projection Mode ON.
3. **Connect:** Cord between phone and USB port on vehicle. The CarPlay icon replaces phone icon on the home page.
4. See Figure 92. **Select:** CarPlay.
5. See Figure 93. Apple CarPlay is now visible on the radio screen.

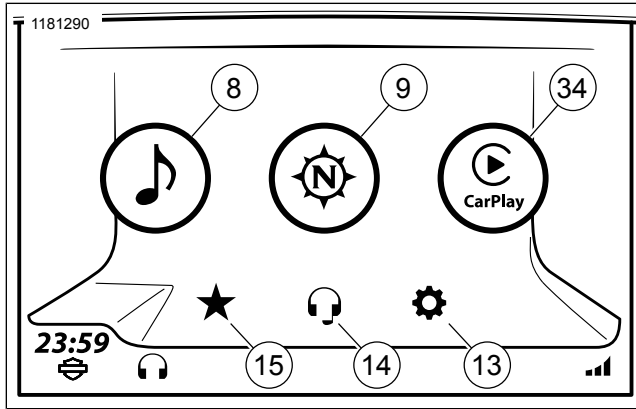

Figure 92. CarPlay on Home Screen

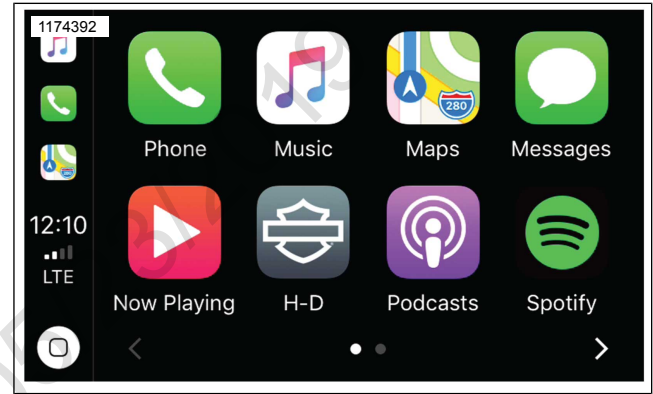

Figure 93. Apple CarPlay Screen

NOTES

© 2019 H-D, 05/23/2019

NAVIGATION

The Navigation features on the GTS system are available in select regions. To prevent distraction while riding, plan your Rides and select destinations before riding the motorcycle.

The navigation system can route to address entries, phone book contacts, point of interest (POI) destinations in the navigation database or by manually selecting locations on the touchscreen map. Domestic (DOM) market vehicles can also do the same plus import Rides and destinations from Ride Planner (<https://maps.harley-davidson.com>) and the H-D App.

NOTE

- *There will be a slight delay after the vehicle or the radio has been powered on while the navigation system initializes. Wait until the system has finished the initialization process before using the navigation system.*
- *There may be some limitations when operating the navigation system in buildings or underground structures (such as tunnels or underground parking).*

One Box Search (OBS)

One Box Search destination entry supports the standard United States and Canadian state/province/territory two-letter abbreviations. User can enter street/city and state/state abbreviations.

1. **Navigate:** Home > Navigation.
2. **Select:** Search.
3. **Select:** Search.
4. See Figure 94. **Input in search field:**
 - a. Latitude/Longitude (Example: 40.44611, -79.98222 or 40° 26' 46" N 79° 58' 56" W or 40.446° N 79.982° W)
 - b. Intersections/Cross Roads (Example: 37th Street and Juneau Avenue. Valid symbols to separate streets: and, &, @, at)
 - c. Street Address (Example: 3700 W. Juneau Avenue Milwaukee WI 53208)
 - d. Phone Number POI search only (Example: 4143434056 and result is Harley-Davidson customer care representative)
 - e. POI search (Example: Gas Stations and result is Sunoco, Mobile, Shell, etc.)

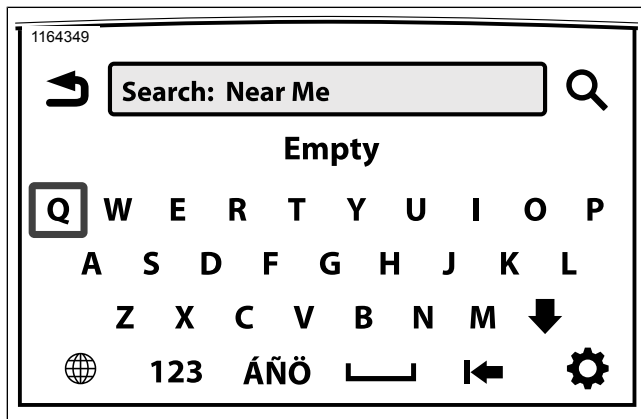

Figure 94. Input Address

Map Compass Setting

NOTE

The motorcycle must be in motion to determine the current heading. If the current heading is not known, the full-size compass displays question marks.

The compass is displayed in the upper right corner of the map. The heading indicator is displayed in the center of the map. The icons operate differently according to the map orientation setting (north up or heading up).

The compass needle is divided into two sections. The red section is the part of the needle that points north. And the white section is the part of the needle that points south.

North Up: The map is always orientated with north up (top of screen). And the compass is always pointed up (north).

Heading Up: The heading directional display will now operate as a traditional compass with the top representing the direction ahead and the rotating needle shall point to the direction of North.

3D or 3 Dimensional: This is the same as Heading Up but the mapping has gone from a two-dimensional plane to three-dimensional points.

NOTE

While on other screens, the system can display current heading in either the left or right data wing. Press data wing and select **Heading**.

Full-Size Compass (equipped without Navigation)

For regions that **do not** support navigation features on the radio, selecting **Navigation** displays a full-size compass.

Navigate: Home > Navigation.

MAP

Display Map

NOTE

See Figure 95. When the **Heading Indicator/Current Position Icon (10)** is fading or flashing, it represents that there is a very low GPS signal. See **GPS Information** in this section.

1. Home Screen:

- a. **Navigate:** Home > Navigation.

2. Left Hand Control:

- a. **Short Press on Home:** Toggles between current screen and Home screen.
- b. **Long Press on Home:** Toggles to Quick Jump screen.

3. Voice Recognition:

- a. Press **Voice Recognition** on left hand control.
- b. Speak **Show Map** into microphone.

4. Quick Jump:

- a. **Long Press on Home:** Toggles to Quick Jump screen.

Some of the highlights for the map screen are:

- **Search:** Used to search, find and select a destination, route, ride or other location that can be used in navigation.
- **Menu:** Select menu to show map and navigation options and their settings.
- **Data Fields:** Select left or right data fields to change information shown in these fields.
- **Next Turn Guidance:** Displays distance, turn information and a repeat icon which will repeat the last navigation voice prompt.

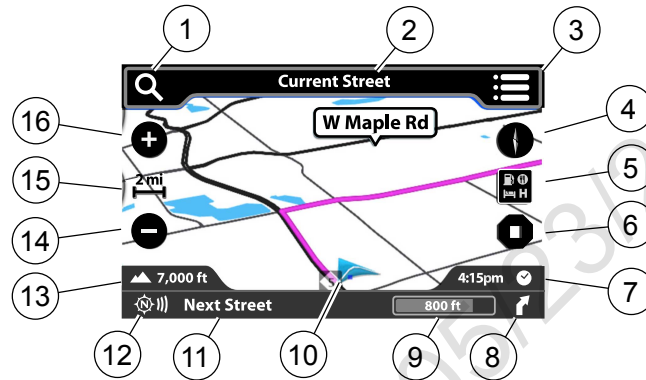

- | | |
|---------------------------------------|---|
| 1. Search | 9. Distance to next maneuver |
| 2. Current street | 10. Heading indicator/current position icon |
| 3. Menu | 11. Next maneuver street |
| 4. Map compass setting | 12. Repeat voice instruction |
| 5. Highway services | 13. Left data field (or current audio source) |
| 6. Stop or pause route, skip waypoint | 14. Zoom out |
| 7. Right data field | 15. Map scale |
| 8. Next maneuver turn | 16. Zoom in |

Figure 95. Navigation Map

Change Map Settings

Map settings will allow the user to select from a list to set the appearance of the screen. Features can be turned on, off or adjusted.

NOTE

* The asterisk denotes system default.

1. **Navigate:** Home > Navigation.

2. **Select:** Menu.
3. **Select:** Settings.
4. **POI Icons:** Check the POI items to be displayed on the map.
5. **Map View:** 2D North*, 2D heading, 3D.
6. **Auto Zoom:** Off*, Near, Normal, Far.
 - a. When auto zoom is enabled, the navigation system will automatically zoom the map view as the vehicle is approaching predetermined locations. Upon passing the location, the navigation system will automatically zoom out to the rider's selected Near/Normal/Far zoom level. When disabled the map zoom level remains fixed at the rider's last setting regardless of the current or approaching locations along the route.
7. **Nav Prompts:** ON/OFF.
 - a. Audio guidance prompts.
8. **Current Street:** ON*/OFF.
 - a. Displays the current street along the top of the map.
9. **Next Street Bar:** ON*/OFF.
 - a. Displays the next turn at the bottom of the map.
10. **Lane Guidance:** ON*/OFF.
 - a. Displays lane guidance arrows along the highlighted route. When a turn is required on a multi-lane highway, the map displays bright orange arrows to suggest the proper lanes. Graphical representations of signposts and junctions are displayed.
11. **Audio Information Bar:** ON/OFF*.
 - a. Displays the current audio source along the bottom of the map.
12. **Left and Right Data Fields:** ON*/OFF. Displays the left and right wing data fields.
13. **Speed and Flow:** ON*/OFF. Displays traffic overlay colors on the map.

14. **Signposts:** ON*/OFF.
15. **Junction View:** ON*/OFF.
16. **3D Terrain:** ON*/OFF.
17. **3D Buildings:** ON*/OFF.
18. **Highway Services:** Enabled/Disabled.
 - a. This helps the rider identify what services are available at the next few highway exits along their route. This also identifies which exit to use.
19. **Motorcycle Icon:** Blue Arrow, Electra Glide, Road Glide or Street Glide.
 - a. Shows position of motorcycle on map.
20. **Restore Defaults:** Selecting **Yes** resets the menu to factory default and goes back to the top of menu.

Change Nav Settings

Map settings allow the user to select from a list to set the appearance of the screen.

Nav settings allow the user to select from a list to set how the NAV engine performs searches, route calculations and displays results.

NOTE

** The asterisk denotes system default.*

1. **Navigate:** Home > Navigation.
2. **Select:** Search.
3. **Select:** Settings.
4. **Search Area:**
 - a. Near Me*
 - b. Around Location
 - c. Near Destination
 - d. Along Route
5. **Route Preferences:**
 - a. Fastest*

- b. Shortest
- c. Twisty
- d. Scenic

6. **Sort Preferences:**

- a. Relevance*
- b. Distance
- c. Alphabetical

NOTE

*Only a single destination is supported by the **Round Trip** option. The icon is disabled when routing is active.*

*If **Round Trip** is checked, the Location is saved as the return point when **Go** is pressed.*

7. **Round Trip:**

- a. ON/OFF

8. **Alternate Routes:**

- a. Different Types*

- b. Same Type
- c. OFF

9. **Avoidance:**

- a. Highways
- b. Toll Roads
- c. Ferries
- d. Tunnels
- e. In-Process Data (IPD)
- f. Car/Train
- g. Unpaved Roads
- h. Seasonal Restrictions
- i. Borders

10. **Restore Defaults:**

- a. Yes or No

Change Data Field

1. **Navigate:** Home > Navigation.
2. **Select:** Left or right data wing field.
3. See Table 38. Choose an option from the list to display in the field. Many of the data field settings (such as Time to Via or Arrival Distance) are only relevant during an active route.

Table 38. Data Field Options

DATA FIELD OPTIONS		
Arrival Distance	Arrival Time	Clock
Current Speed	Elevation	GPS Accuracy
Heading	Moving Time	Overall Average Speed
Speed Limit	Stopped Time	Temperature
Time Remaining	Time To Turn	Time To Via
Total Time	Via Distance	

Map Navigation Option Menu

1. **Navigate:** Home > Navigation.
2. **Select:** Menu.

NOTE

* The asterisk denotes if the route is active, the option is displayed.

The following options are available:

- Stop*
- Pause*
- Skip Waypoint*
- Location
- Maneuvers
- Destination*
- Weather
- Traffic
- Fuel Prices

Route Preferences and Avoidances

Route Preferences is selected if the rider is looking for a specific type of road or path for their route calculation: Scenic, Fastest, Shortest, Twisty.

Selections can also be made to avoid specific types of roads or routes during a calculation such as: Highways, Toll Roads,

Ferries, Tunnels, In-Process Data (IPD), Car/Train, Unpaved Roads, Seasonal Restrictions, Borders.

1. **Navigate:** Home > Navigation.
2. **Select:** Search.
3. **Select:** Settings.

Auto zoom

Auto zoom can be set up one of four ways when the rider's touchscreen map approaches it predetermined location.

1. **Navigate:** Home > Navigation.
2. **Select:** Menu.
3. **Select:** Settings.
4. Select **Auto Zoom** to the desired option:
 - a. **OFF:** Auto zoom is disabled.
 - b. **Near:** Will return to narrow scale.
 - c. **Normal:** Will return to middle scale.

- d. **Far:** Will return to wide scale.

Map Scrolling: Touchscreen

1. With the map displayed, press on the touchscreen. The scrolling tool (circle with arrows) is shown on the map. The title bar displays the name of the street that is being viewed.
2. **Scroll:** Press and hold the screen to scroll.
3. **Jump:** Press another location on the map to jump.
4. **Route to Location:** Select icon in upper right corner of map to route to location.
5. **End Scrolling:** Select back to end scrolling and return to current position on map.

Map Scrolling: Hand Controls

1. **Select:** Top title bar.
2. **Press and Release:** Cursor/Select on right hand control.
3. **Select:** Arrow down to engage scrolling.

4. **Select:** Directional arrow with Cursor/Select. Press and hold to scroll to destination.
5. **Route to Location:** Select the center circle to route to the location on the map.

Selecting POI on Map

NOTE

Use Map Scrolling Hand Controls.

POI icons are only visible on the map at closer zoom levels. See Change Map Settings to change the types of POI icons that are displayed on the map.

1. See Figure 96. **Scroll:** POI icon on map. Zoom-in close to the icon.
2. Refer to Table 39. **Select:** POI location in the circle. The radio calculates a route to the selected POI. If multiple POIs are in the same location, the system prompts with a list of POIs.
3. **Select:** Option icon to show more POI options. Otherwise, select **Go** to begin route.



Figure 96. POI on Map



Table 39. POI Icons

ICON	DESCRIPTION
	ATM/Banking
	Automotive
	Airport
	Coffee shop
	Community
	Entertainment

Table 39. POI Icons

ICON	DESCRIPTION
	Gas stations
	Harley-Davidson
	Health and beauty
	Highway exit
	Hospital
	Hotel/Motels
	Other
	Parking
	Recreation
	Rest Areas
	Restaurant

Table 39. POI Icons

ICON	DESCRIPTION
	Shopping
	Travel

ROUTE

Route To Destination: Address

1. **Navigate:** Home > Navigation.
2. **Select:** Search.
3. **Select:** Search.
4. **Enter address.**

NOTE

- The system uses the smart speller to narrow entries according to the contents of the navigation database.
- The system provides lists of possible destinations based on the input. For example, entering "Birch Street" generates a list of all cities with a "Birch Street" in the database.

- *As a minimum, the system requires either a postal code or a city and state. If a street address is not entered, the system navigates to the city center. Requirements may vary slightly according to region.*

Route To Destination: Home

NOTE

If home is not programmed, see Saving A Destination: Home

1. **Navigate:** Home > Navigation.
2. **Select:** Search.
3. **Select:** Go Home.

NOTE

- *To delete or change the home destination, activate a route to home and select **Options** on the Go Home screen.*
- *Once a home address has been saved, a voice command can also be used to navigate home. Press the **Voice Recognition** switch and say **Home**.*

Route To Destination: Recent

1. **Navigate:** Home > Navigation

2. **Select:** Search.
3. **Select:** Recent.
4. Select a recent route from list. Select **Go**.

Route To Destination: Contacts

1. **Navigate:** Home > Navigation
2. **Select:** Search.
3. **Select:** Contacts.
4. **Select:** Phone or Radio.
5. **Select:** Address and route to destination.

Route To Destination: Saved

1. **Navigate:** Home > Navigation
2. **Select:** Search.
3. **Select:** Saved.

4. **Select:** Saved item from list.
5. **Select:** Route/View.
6. **Select:** Go from Destination screen.

Route To Destination: Map Scroll Tool

NOTE

Use Map Scrolling Hand Controls.

1. With the map displayed, press on the touchscreen to activate the scrolling tool.
2. Scroll to a location or POI.
3. Select the center circle to route to the location or POI on the map.
4. **Select:** Go.

NOTE

See Map (Page 139) for scrolling operation.

Route To Destination: POI

1. **Navigate:** Home > Navigation
2. **Select:** Search.
3. **Select:** POI's.
4. **Select:** Item from Category list.
5. **Select:** Item from subcategory list.
6. Select a location from list. Select **Go**.

Route To Destination: Dealership

1. **Navigate:** Home > Navigation
2. **Select:** Search.
3. **Select:** H-D Bar and Shield.
4. Select a location from list. Select **Go**.

Route To Destination: Emergency

1. **Navigate:** Home > Navigation

2. **Select:** Search.
3. **Select:** Emergency.
4. **Select:** Hospital, Police or Fire Dept.
5. Select a location from the list. Select **Go**.

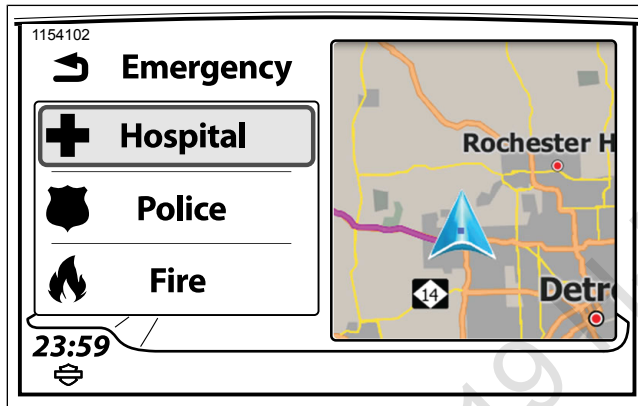

Figure 97. Route To Destination: Emergency

Route To Destination: Coordinates

1. **Navigate:** Home > Navigation.

2. **Select:** Search.
3. **Select:** Search.
4. **Input:** Latitude and longitude coordinates. The formats can include heading (h) such as North, degrees (d), minutes (m), and seconds (s).
 - a. h ddd.dddd°
 - b. h ddd° mm" ss.s'
 - c. h ddd° mm.mmm'

Table 40. Destination Coordinates

Format Examples	
Latitude, Longitude	40.44611, -79.98222
Degrees,Minutes,Seconds	40° 26' 46" N 79° 58' 56" W
Degrees,Decimal,Minutes	40° 26.767' N 79° 58.933' W
Decimal Degrees	40.446° N 79.982° W

Route to Destination: Fuel

NOTE

The radio must have a SiriusXM subscription for this feature to work.

1. **Navigate:** Home > Navigation.
2. **Select:** Menu.
3. **Select:** Fuel Prices.
4. **Select:** Fuel type. Back out of screen when selection is made.
5. **Select:** View Prices.
6. See Figure 98. Select a fuel station from list.

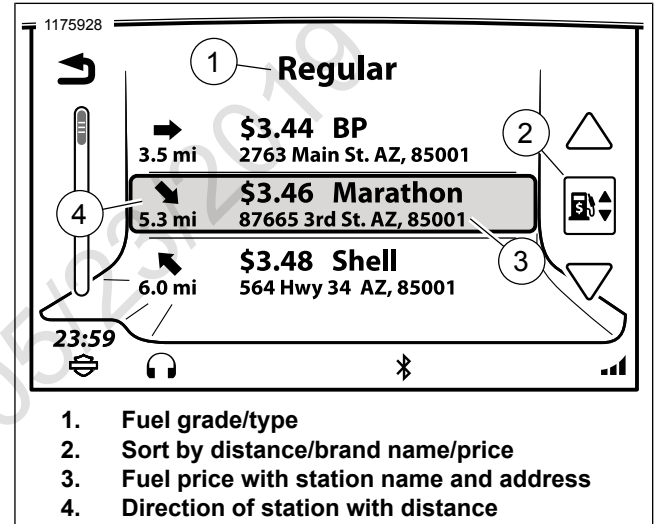

Figure 98. Station Selection

7. See Figure 99. **Select:** Route/View.

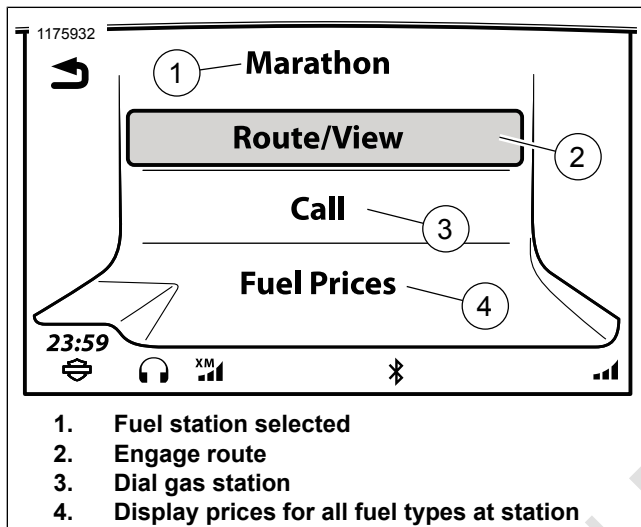

Figure 99. Route/View

8. **Select:** Go.

Route To Destination: Voice Command

1. With route active, press the **Voice Recognition** button on left hand control.

2. Select one of the following:
 - a. **Route to Destination: Address** Speak **Destination** followed by the address.
 - b. **Route to Destination: Saved** Speak **Favorite** followed by the saved destination name.
 - c. **Route to Destination: POI** Speak **Find Next** followed by the type of destination or brand name (such as **Bank** or **Gas Station**).

Route to Destination: Repeat Navigation Instruction

1. See Figure 100. **Select:** Repeat icon (1). This will repeat the last command given by navigation.

Canceling or Pausing a Route: Using Menu

1. See Figure 100. **Select:** Stop icon (2) on the map screen.
2. **Select:** Stop or Pause.

NOTE

When selecting a new route, the system provides a notification to either add or replace the existing route. There is no need

to manually cancel the current route when adding or replacing it with a new route.



Figure 100. Navigational Instruction

Canceling a Route: Voice Command

1. **Press:** Voice Recognition switch on left hand control.
2. **Speak:** Cancel route guidance.

Showing a Planned Route

NOTE

An entered route is displayed before committing to the route.

1. **Navigate:** Home > Navigation.
2. Select a Destination to route.
3. **Select:** Options.
4. **Select:** Show Route. The map shows the entire highlighted route.
5. To commit to the route, select **Back** twice.
6. **Select:** Go.

Simulating a Route

A route simulation can be viewed before committing to the route. The route simulation can only be used while the motorcycle is not moving.

1. **Navigate:** Home > Navigation.
2. Select a Destination to route.

3. **Select:** Options.
4. **Select:** Simulate Route. The route simulation is played on the map. Audible turn guidance will also be played.
5. To commit to the route, select **Back** twice.
6. **Select:** Go.

Calling a Destination: Route Active

There are occasions when calling a destination is helpful to determine operating hours or get information.

1. With a phone connected and a route active on the map, select the **Menu** button.
2. **Select:** Destination.
3. **Select:** Call.

Calling a Destination: Route Not Active

1. With a phone connected, select a destination (such as a POI).
2. **Select:** Call. This is on the Destination screen.

Saving A Destination

NOTE

When the current destination list consists of more than one destination, it may have originated as either a Ride, or from the user adding one or more stopovers one at a time, or both.

The current location is stored as a Saved destination or can be saved as the Home destination when the option is displayed.

1. **Navigate:** Home > Navigation.
2. **Select:** Menu.
3. Select a destination (such as a POI, address, recent destination or GPS coordinate).
4. **Select:** Save. This is after the route is calculated.
5. From **Save To** screen, select **Saved List**.
 - a. From **Destinations** screen, select **Save As Ride**.
 - b. **Enter:** Name to be saved as Destination.
6. **Select:** OK.

Saving A Destination: Home

1. **Navigate:** Home > Navigation.
2. **Select:** Search.
3. **Select:** Go Home.
4. From **Set Home** screen, select a destination (perform a search, select a recent destination, select a POI or a Saved file).
5. **Select:** Save.
6. **Select:** As Home.

Saving Current Location

The current location is stored as a Saved Destination or can be saved as the Home Destination when the option is displayed.

1. **Navigate:** Home > Navigation.
2. **Select:** Menu.
3. **Select:** Location.

4. **Select:** Save.
5. From **Save To** screen, select **Saved List**.
 - a. From **Add to Saved Destinations?** screen, select **Yes**.
 - b. **Enter:** Name to be saved as Destination.
6. **Select:** OK.

RIDES

Rides are useful when visiting a number of POIs during an extended ride, planning rides with intermediate destinations (waypoints) or when planning a ride with restaurants and overnight lodging. The number and limit of Rides can only be determined by the amount of storage space available in the system. Each ride can include up to 400 destinations (waypoints).

A ride can be created using the navigation menus or by creating a ride on the map screen. Rides can also be imported from Ride Planner which is available for domestic (DOM) markets only. See Importing a Route (Page 162).

Creating a Ride: Using Menus

1. **Navigate:** Home > Navigation.

2. **Select:** Search.
3. **Carousel to:** Rides.
4. **Select:** New.
5. **Input:** Name of your ride and select OK.
6. **Select:** Edit.
7. **Select:** Add destination.
8. **Select:** Search, Map, Recent, Saved, POI's or Contacts. Use one of the methods to enter a destination.
9. **Select:** Add in the Destination screen.
10. **Select:** Start Route.

Creating a Ride: Using Map

1. **Navigate:** Home > Navigation.
2. With map displayed, press touchscreen.
3. Scroll to a POI or location on the map.

4. **Select:** Go (upper right corner).
5. **Select:** POI or location to confirm.
6. **Select:** Options. Adjust ride preferences if needed.
7. **Select:** Go.

Round Trip

When the **Round Trip** function is enabled, the system calculates a return route to the original position of the vehicle. The round trip feature can only be enabled before a route is activated.

1. **Navigate:** Home > Navigation.
2. **Select:** Search.
3. **Select:** Settings.
4. **Select:** Round Trip.

Editing a Ride: Adding Waypoints In Menu

1. **Navigate:** Home > Navigation.

2. **Select:** Search.
3. **Select:** Rides.
4. Select current ride destination.
5. **Select:** Edit.
6. **Select:** Add Destination.
7. Enter a destination (address, POI, recent destination, saved location or intersection).
8. **Select:** Add.
9. **Screen:** Add Another Destination.
 - a. **Select:** No. System returns to ride screen.
 - b. **Select:** Yes. Add waypoints as needed.
10. Reorder waypoints as needed.
11. **Select:** Start Route.

Editing a Ride: Adding Waypoints On Map

NOTE

A Ride must be already programmed into the radio.

1. **Navigate:** Home > Navigation.
2. With map displayed, press touchscreen.
3. Scroll and select a POI or location on the map between the start and end of the ride.
4. **Select:** Go (upper right corner).
5. **Select:** POI or location to confirm.
6. **Select:** Route.
7. **Select:** Add.
8. **Select:** Go.

Editing a Ride: Reordering Waypoint

NOTE

*There has to be a minimum of three destinations pre-populated in the **Rides** for this operation to work.*

1. **Navigate:** Home > Navigation.
2. **Select:** Search.
3. **Select:** Rides.
4. Select a ride from list.
5. **Select:** Edit.
6. **Select:** Reorder.
7. See Figure 101. Select a destination (1) to reposition.

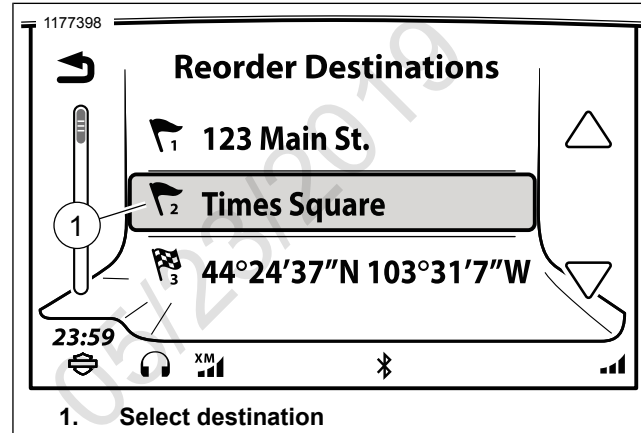

Figure 101. Select Destination

8. See Figure 102. A double arrow (2) will appear on the selection meaning it is ready to move.

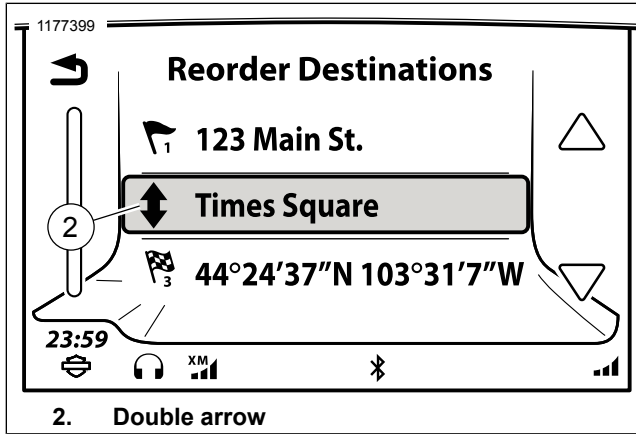

Figure 102. Double Arrow

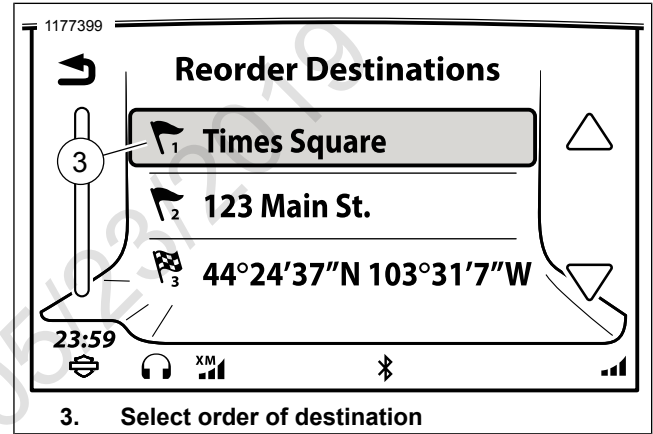

Figure 103. Move Destination

9. See Figure 103. Select order of destination (3) by pressing the position where it needs to be moved.

10. Back out to ride screen.

11. **Select:** Start Route.

Editing a Ride: Skipping Next Waypoint

1. With an active route, select **Menu**.
2. **Select:** Skip.
3. **Select:** Yes.

Editing a Ride: Skipping Waypoint

1. With an active route, select **Menu**.
2. **Select:** Destination.
3. **Select:** Edit.
4. **Select:** Remove Destination.
5. **Select:** Waypoint to skip.
6. **Select:** Yes. The system removes the waypoint from the current route. However, the waypoint is not removed from the originally stored ride.

TRAILS

A trail is a specific path which is recorded during your ride. While the trail is recording, the system stores ongoing location points along the ride. This is different than saving a destination or ride, which only store a number of locations rather than a specified path.

A trail can be used to repeat the ride along the same path in the future or to route back to the start of the trail using the same path.

A trail can be recorded at any time. A route does not need to be active to begin recording a trail.

The maximum amount of Trails the radio can record is 20. When the number of Trails is at capacity, the **Start Recording** icon will be enabled and following message is displayed **Maximum number of trails reached. Please delete a trail first..**

Record a Trail

1. **Navigate:** Home > Navigation.
2. **Select:** Search.
3. **Select:** Trails.
4. **Select:** Start recording. The trail begins recording.

NOTE

*Turning off the vehicle does not **stop recording** a trail. Recording needs to be stopped manually in order for a trail file to be created.*

5. **Select:** Stop recording. The trail stops recording and is stored in the list of trails.

Rename a Trail

1. **Navigate:** Home > Navigation.
2. **Select:** Search.
3. **Select:** Trails.
4. **Select:** Trail from list.
5. **Select:** Rename.
6. Use keyboard to enter new name and select OK.

Navigating a Trail

A trail can be used to ride the originally recorded route (from start to end) or a return route (from end to start). When selecting a trail, the route includes navigation from your current location to the beginning of the trail.

1. **Navigate:** Home > Navigation.
2. **Select:** Search.
3. **Select:** Trails.

4. **Select:** Trail from list.
5. **Select:**
 - a. **Route to Start:** Take return route (end to start).
 - b. **Route to End:** Take original route (start to end).

Deleting a Trail

1. **Navigate:** Home > Navigation.
2. **Select:** Search.
3. **Select:** Trails.
4. **Select:** Trail from list.
5. **Select:** Delete.

EXPORTING A ROUTE

A ride, trail or saved destination can be exported to a USB storage device. The system exports the set of routes as a GPX file named "H-D_NavData.gpx". If needed, the system adds a sequential number to prevent overwriting other previously saved files (such as "H-D_NavData(1).gpx").

Multiple rides or destinations can be contained in a single GPX file.

The export feature is designed to back up routes or share routes with other riders that have a Boom! Box system. While the GPX file may be imported into other GPS devices, there may be limitations on compatibility.

NOTE

The USB device must be formatted to exFAT or FAT32 (typical format used by PCs) to support data exports. NTFS-formatted devices are read-only and do not support GPX export.

1. While stopped, connect a USB device to store the files.
2. **Navigate:** Home > Navigation.
3. **Select:** Search.
4. **Select:** Export.
5. **Select:** USB device.
6. A list of rides, trails and saved destinations are displayed.
7. **Select:** Checkboxes for items to be exported or choose select all.

8. **Select:** Export.

9. **Select:** OK when export is complete. The USB device can be removed.

IMPORTING A ROUTE

NOTE

RIDE PLANNER AND THE H-D APP ARE FOR DOMESTIC VEHICLE USE ONLY.

When using GPX files, after being imported onto the GTS radio unit via USB or Mobile App, the Alternate Routes needs to be set to OFF. This will make the GPX Route accurate to design on the Ride Planner website or H-D App.

The system can import ride, trail and destination files saved in GPS Exchange Format (GPX). The files may have been exported by another motorcycle equipped with a Boom! Box, created by Ride Planner (<https://maps.harley-davidson.com/>) or using the H-D App. A single GPX file may contain multiple rides and destinations.

The system can use GPX files exported by other GPS devices or mapping websites. While GPX is a standard format for navigation files, due to differences in how the file is generated and the data in that file from different programs, there may be some differences in the route once imported. Differences

may be in the destinations or waypoints on the route or the route path between points. Review the route before riding.

Imported routes are stored in respective locations within the radio. Destinations are stored in the Saved list. Imported rides are stored in the Rides list. Imported phone book contact files (V-card files, VCF) are added to the Book list in the navigation menu. In some instances, the imported GPX file may load as a trail instead of a ride due to the data from other mapping sites.

Harley-Davidson recommends using Ride Planner (<https://maps.harley-davidson.com>) for creating, saving and exporting routes to guarantee system compatibility.

There are two methods for getting Rides on to the GTS radio: USB Drive and H-D App.

USB Drive

1. Position vehicle in a stationary position and set ignition in the ON or ACCY position.
2. Connect a USB device containing the GPX or VCF files to the vehicle.
3. **Navigate:** Home > Navigation.
4. **Select:** Search.

5. **Select:** Import. A list of GPX and VCF files are displayed.
6. **Select:** GPX or VCF file. A list of all Saved Rides, Trails and Destinations within the GPX file are displayed.
7. **Select:** Saved Rides, Destinations and Contacts to import.
8. **Select:** Import.
9. **Select:** OK.
10. Procedure is complete and the USB drive can be removed.

Mobile App

1. Download the **Harley-Davidson App** onto your phone.
 - a. Apple iPhones see **App Store**.
 - b. Android phones see **Play Store**.
2. Position vehicle in a stationary position and set ignition in the ON or ACCY position.
3. Log in to the H-D App.

4. Connect phone using a USB cable (iOS only) or Bluetooth connection (works for both iOS and Android).
 - a. If the phone is connected properly and a valid user has logged in, **H-D App** should be illuminated.
5. **Navigate:** Home > Navigation.
6. **Select:** Search.
7. **Select:** H-D App. A list of My Rides list will be displayed.
8. **Select:** Ride from list. The contents will immediately be saved to the radio.
9. 6. The radio will automatically display the first segment of the imported Ride, prompting the rider to **Start**.

TRAFFIC

See Figure 104. The navigation system can provide traffic information when RDS Traffic (TMC) or SiriusXM Traffic is equipped on the vehicle and available in the region. When traffic is enabled, the map shows traffic flow and events along the currently selected route. Refer to Table 41. and Table 42 for traffic icon descriptions.

The system also stores a list of all traffic events that are nearby or along the active route. When an event (such as an accident or lane closure) is discovered along the current route, the navigation system notifies of the event and may attempt to calculate an alternate route. The system will either prompt to make the change or will automatically adjust the route, according to the system settings.

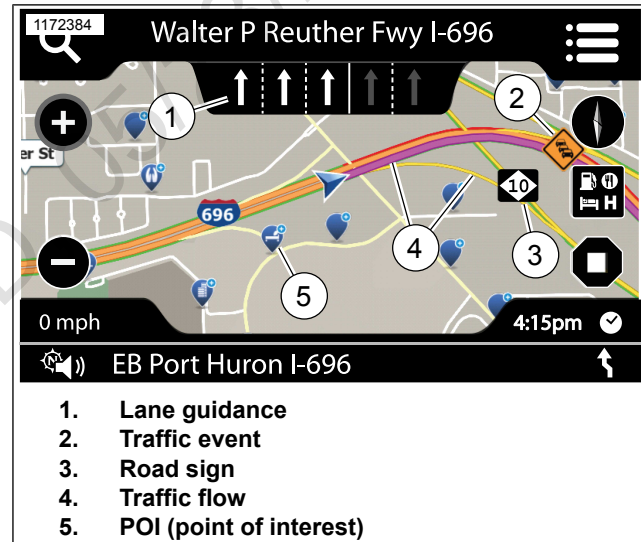

Figure 104. Traffic

Table 41. Traffic Conditions

COLOR	ICON	DESCRIPTION
Green overlay	Thin line	Free flowing traffic
Yellow overlay	Thin line	Slow traffic
Red overlay	Thin line	Stopped
Magenta overlay	Thick line	Active route
Teal overlay	Thick line	Recorded trail

Table 42. Traffic Conditions



























ICON (NA)	ICON (EU)	DESCRIPTION
		Accident
		Construction
		Warning
		Narrow road
		Security checkpoint
		Weather
		Frost
		Blockage
		Slippery
		Traffic

Table 42. Traffic Conditions

ICON (NA)	ICON (EU)	DESCRIPTION
		Heavy traffic
		Information
		Wind

Turning Traffic On/Off

On equipped vehicles, traffic automatically turns on with the RDS traffic feature or when selecting the SiriusXM traffic feature.

1. **Navigate:** Home > Navigation.
2. **Select:** Menu.
3. **Select:** SXM traffic or TMC traffic.
4. **Select:** Settings.
5. Check (enable) or uncheck (disable) the **Traffic** checkbox.

Traffic Notification Settings

1. **Navigate:** Home > Navigation.

2. **Select:** Menu.
 3. **Select:** SXM traffic or TMC traffic.
 4. **Select:** Settings.
 5. **Select:** Notification.
 6. **Selections Displayed:**
 - a. **Popup Beep:** Beep when traffic popup is displayed.
 - b. **Message Filter:** Choose the maximum distance of traffic events to be displayed in the event list.
4. **Select:** Settings.
 5. **Select:** Re-route to Off or Auto.
 - a. **Auto:** The system will automatically adjust the route according to traffic data.
 - b. **Off:** The system will not prompt with any new routes based on traffic data.

Traffic Event List: RDS Traffic

If a route is active, the system displays traffic events along the route. If a route is not active, the system displays all nearby traffic events.

Rerouting

The system can be configured to manually or automatically select a new route based on traffic data. The system will only provide a new route when it is calculated to be at least five minutes faster than the current route.

1. **Navigate:** Home > Navigation.
 2. **Select:** Menu.
 3. **Select:** SXM traffic or TMC traffic.
1. **Navigate:** Home > Navigation.
 2. **Select:** Menu.
 3. **Select:** SXM traffic or TMC traffic.
 4. See Figure 105. Select traffic message (1) from list.

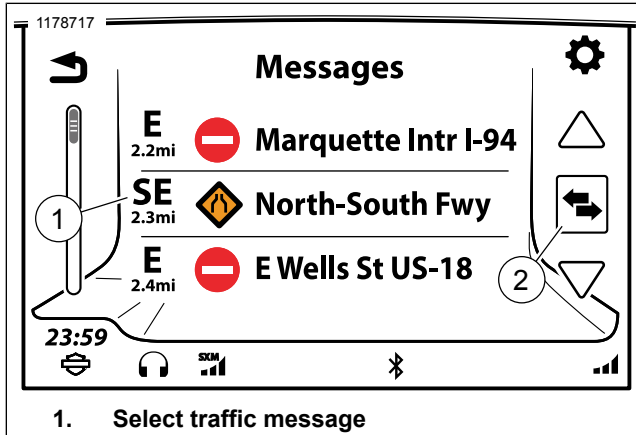

Figure 105. Traffic List

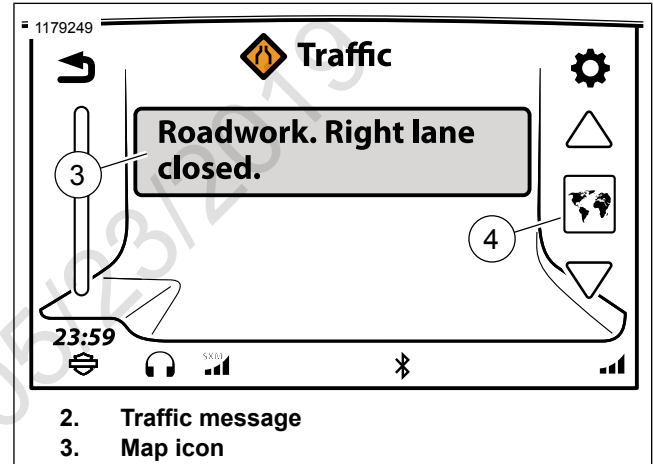

Figure 106. Traffic Message

5. See Figure 106. The traffic message (2) is displayed. Select message on screen to hear voice recognition.
6. **Select:** Map. This will display the event location on the map.

Maneuvers: Turn-By-Turn Instructions

While the route is active a list of turns will be displayed to your destination.

1. **Navigate:** Home > Navigation.

NOTE

Select the next turn displayed at the bottom of the map as a shortcut to bypass Steps 2 and 3.

2. **Select:** Menu. This must be done in an active route.
 3. **Select:** Maneuvers. A list of all turns in the route are displayed.
 4. Selecting a next turn from the maneuvers list displays the following options:
 - a. **Avoid:** The system calculates new directions to avoid the selected road.
 - b. **Zoom:** The map displays the selected maneuver on the map.
 - c. **OK:** Returns to the list of maneuvers.
2. **Select:** Menu.
 3. **Select:** Maneuvers. A list of all turns in the route are displayed.
 4. From the displayed list, scroll and select a turn that you would like to perform a detour.
 5. **Select:** Avoid. The system calculates new directions to avoid the selected road.
 6. **Select:** Yes. A new detour route is calculated and displayed in the list.
 7. **Select:** Back. This sends you back to the active map screen.

Maneuvers: Avoid a Road

NOTE

This must be done in an active route.

1. **Navigate:** Home > Navigation.

NOTE

Select the next turn displayed at the bottom of the map as a shortcut to bypass Steps 2 and 3.

Maneuvers: Zoom

NOTE

This must be done in an active route.

1. **Navigate:** Home > Navigation.

NOTE

Select the next turn displayed at the bottom of the map as a shortcut to bypass Steps 2 and 3.

2. **Select:** Menu. This must be done in an active route.
3. **Select:** Maneuvers. A list of all turns in the route are displayed.
4. From the displayed list, scroll and select a turn that you would perform a Zoom.
5. **Select:** Zoom. The map shows the maneuver with details on the bottom of the screen.
6. **Select:** Previous/Next Maneuvers arrow. This will display the previous or next turn from the list.

Maneuvers: Restoring an Avoided Road

NOTE

This must be done in an active route.

1. **Navigate:** Home > Navigation.

NOTE

Select the next turn displayed at the bottom of the map as a shortcut to bypass Steps 2 and 3.

2. **Select:** Menu. This must be done in an active route.

3. **Select:** Maneuvers. A list of all turns in the route are displayed.
4. See Figure 107. **Select:** Avoid road.

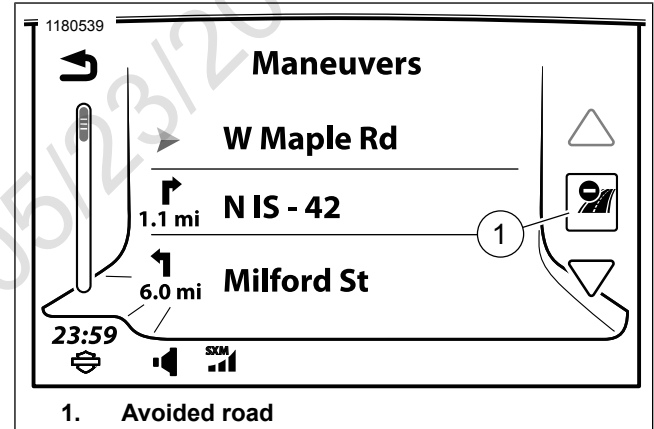

Figure 107. Avoided Road

5. Select the road that was avoided. This would be the **Avoid a Road** selection that was made in a previous topic in this section.
6. See Figure 108. **Select:** Detour.

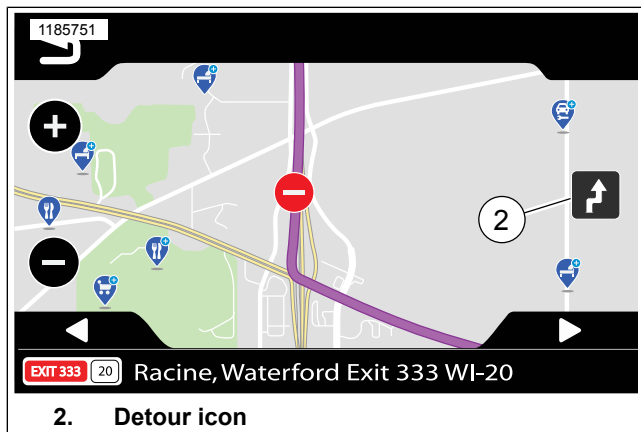

Figure 108. Detour Icon

Lane Guidance

See Figure 109. When an upcoming turn or road divergence is required on a multi-lane highway, the map displays lane guidance arrows to suggest the proper lanes to use. Safely change to the suggested lane and follow the direction of the white arrows.

When approaching the turn, the system shows a representation of the signposts and upcoming road junction. Continue to follow the guidance of the white arrows.

7. **Select:** Yes. When asked to **Restore this Maneuver?**
8. **Select:**
 - a. **Back Once:** This returns rider back to maneuver list.
 - b. **Back Twice:** This returns rider back to map.

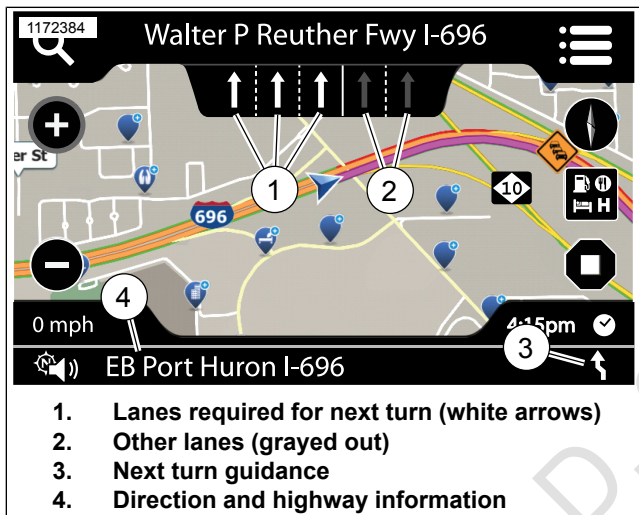

Figure 109. Lane Guidance

Trip Summary

NOTE

This must be done in an active route.

A summary of the current route can be displayed at any point during a ride. The summary shows start and end time, mileage information and other data.

1. **Select:** Info. This is on the radio's faceplate.
2. See Figure 110. **Select:** Trip Summary.

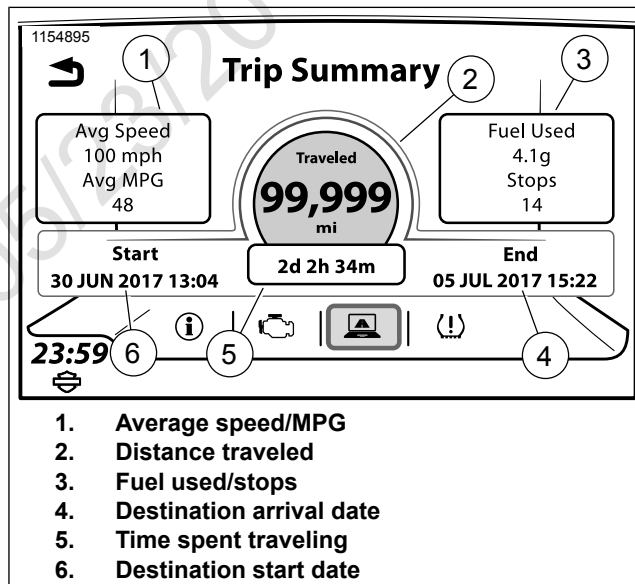

Figure 110. Trip Summary Screen

Low Fuel Alert

When the vehicle detects low fuel, the radio shows an alert and prompts to search for nearby fuel stations. The low fuel alert automatically displays even when the radio is turned off.

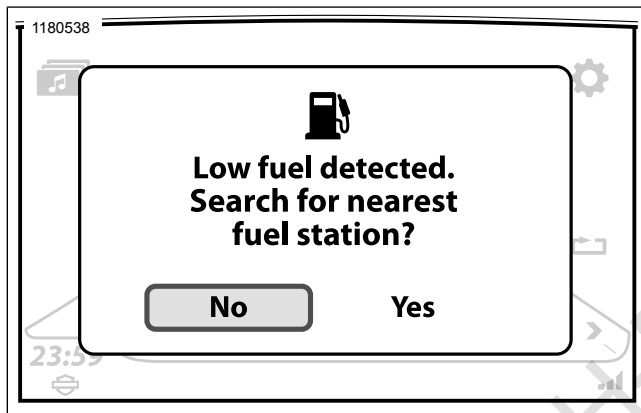

Figure 111. Low Fuel Alert

GPS Information

1. **Navigate:** Home > Navigation.
2. **Select:** Menu.

3. **Select:** Location. The system displays the GPS coordinates and address for the current location (if available).
4. **Select:** GPS. The system displays coordinates, elevation, signal and position information. See Figure 104.

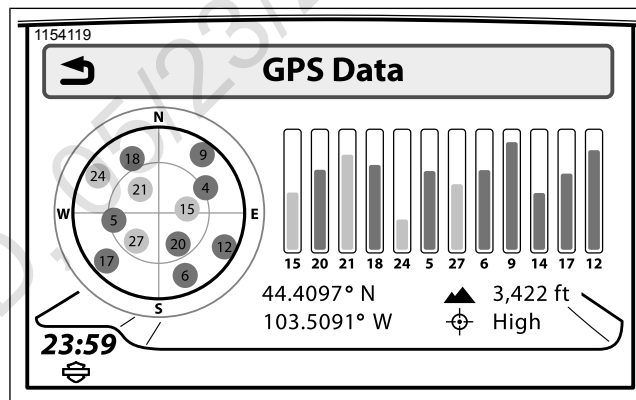

Figure 112. GPS Information

NAVIGATION PROMPTS

Navigation Prompts: Turning On/Off

1. **Navigate:** Home > Navigation.

2. **Select:** Menu.
3. **Select:** Settings.
4. Check (enable) or uncheck (disable) the **Nav Prompts** checkbox.

Navigation Prompts: Adjusting Volume Using Menus

1. **Navigate:** Home > Setup > Audio Settings.
2. **Select:** Volumes.
3. **Select:** Speaker or headset.
4. **Adjust:** Prompt/Nav volume.

Navigation Prompts: Adjusting Volume with Hand Controls

While a prompt is being heard, adjust the volume using the left hand control. All prompts are adjusted to the selected level: Speaker or headset.

Navigation Prompts: Speaker/Headset Selection

1. **Navigate:** Home > Setup > Audio Settings.
2. **Select:** Audio Routing.
3. In **Prompts** select speaker or headset.

NAVIGATION DATABASE AND SOFTWARE

Update, replacement and restoration map databases are downloaded from <https://harleydavidson.welcome.naviextras.com>.

Update: Motorcycles are delivered with the latest map database. Newer database versions are periodically released and are made available for purchase.

Intercontinental Replacement: Riders traveling outside of their home navigation database area can purchase a replacement database which covers the intended area of travel.

Intercontinental Restoration: After returning from extended travel in a different continent or in a region requiring a unique database, the navigation database can be restored to its home database.

Download the Toolbox to install free updates and purchase a wide variety of maps. Once you connect your navigation device to the Toolbox, you can browse and purchase compatible items in the online catalogue. In addition, the application enables you to upload your own points of interest onto your device, remove unnecessary content and to make backups to avoid any data loss.

NOTE

Supported platforms: Windows 7, Windows 8, Windows 10 or OS X 10.8 (or later). Note that Toolbox requires a minimum display resolution of 1024 x 768 and 10-GB free space on your hard drive.

For step-by-step instructions, download the detailed user guide.

1. Insert a USB drive into your Boom!™ Box GTS Navigation System and save its navigation data.
2. Download the Toolbox and insert the USB drive.
3. Follow the instructions on the screen to update your map.
4. Insert the USB drive into your Boom!™ Box GTS Navigation System and upload the data.

RIDE PLANNER

NOTE

*Rides created using the Ride Planner (<https://maps.harley-davidson.com>) or H-D App can be transferred to the GTS radio using a phone with the H-D App installed. See *Importing a Route* (Page 162).*

1. Connect a USB drive to the computer. The USB drive must be formatted to FAT32 or exFAT (commonly used by most PCs).
2. Open Ride Planner in <https://maps.harley-davidson.com>
3. **Select:** Create a new Ride or existing Ride.
 - a. See Figure 113. Add locations for major destinations, such as the start point and end point.
 - b. Add waypoints for other minor stopping points or desired roadways to be traveled.
4. **Select:** Download GPX.
5. Save GPX file to USB drive and rename file as your destination.

6. Remove USB drive and connect it to the radio. See *Importing a Route* (Page 162).

NOTE

- See *Figure 114*. Ride Planner exports each pair of locations as a separate Ride (even though the entire Ride is exported as a single GPX file). In the example, the route from Location 1 to Location 2 (with the intermediate waypoints) is exported as a Ride. The route from Location 2 to Location 3 is exported as a separate Ride.
- The Boom! Box navigation system does not differentiate between locations and waypoints. All items are imported as destinations.
- Ride Planner exports locations and waypoints into the GPX file. It does not export the highlighted route. The exact routing between destinations may be calculated differently within the radio than shown in Ride Planner. To plot a particular path, you may need to add waypoints along the desired route. See *Rides* (Page 155).

© 2019 H-D, 05/2019

om02058

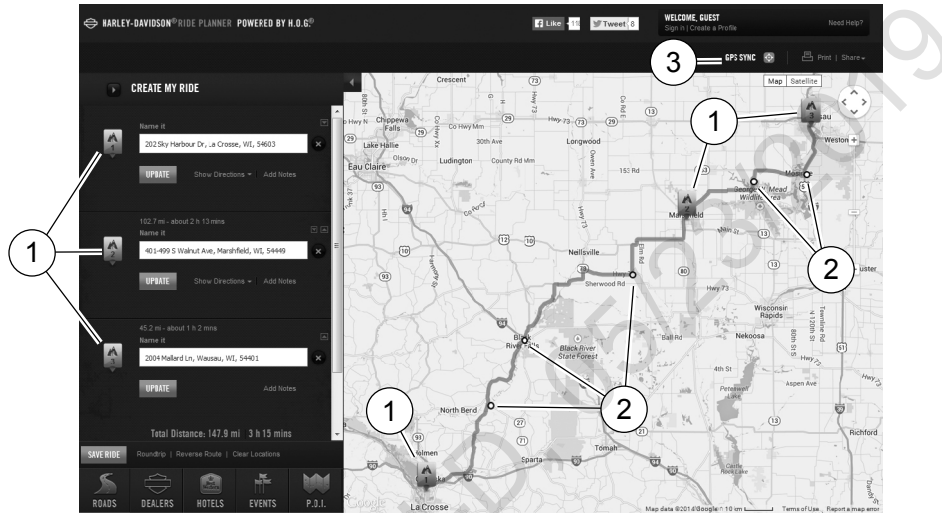

- 1. Locations
- 2. Waypoints

- 3. GPS Sync (export to GPX file)

Figure 113. Ride Planner

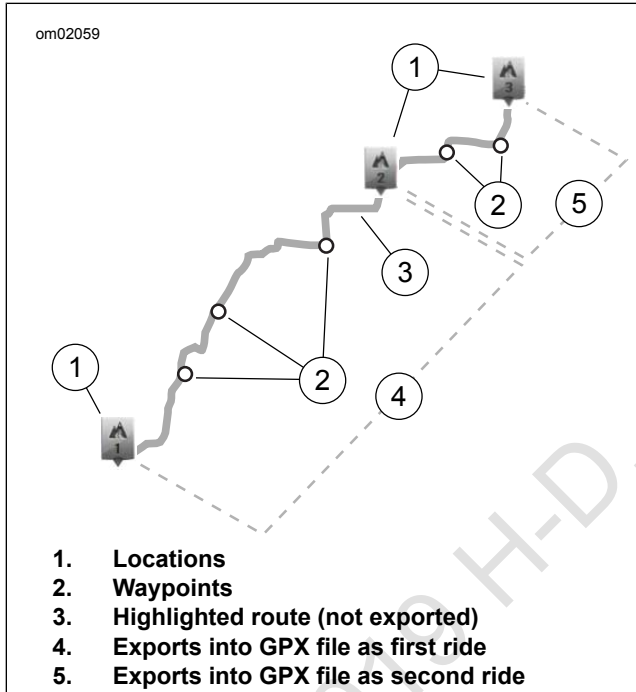

Figure 114. Ride Planner Example

NOTES

© 2019 H-D, 05/23/2019

VOICE RECOGNITION

Voice Recognition

Voice recognition provides a hands-free alternative to operate many Boom! Box functions. Commands spoken into a headset microphone can instruct the system to play a media file, make a phone call, navigate to a destination, tune to a frequency or perform other features. Voice commands can be used to access functions that are otherwise locked out while the motorcycle is in motion.

To make full use of the system and to reduce distraction while riding, take time to learn voice commands for features that you commonly use.

NOTE

Some vehicles do not have headset connectors. A P&A headset connection kit or Wireless Headset Interface Module (WHIM) kit must be installed on the vehicle to use voice command functions.

Activating Voice Recognition

1. Press the Voice Recognition hand control switch. The system beeps and prompts for a command. The system shows a list of commands (teleprompter). The voice recognition icon appears in the status bar.

2. After the beep, speak a command into the headset microphone.
3. Respond to the system with additional information if needed.
 - a. **Prompts:** The system prompts if additional information is required to complete a command.
 - b. **Multiple options:** If multiple options are available for your command, the system displays a numbered list of options to choose from. Speak the appropriate line number, such as **LINE TWO**.
 - c. **Barging in:** To interrupt the prompt, press the Voice Recognition switch during the prompt and speak the desired command after the beep.

Canceling Voice Recognition

Hand control: Press and hold the Voice Recognition switch.

Voice command: At any time, say Cancel to terminate the current session.

No valid input: If the system does not recognize a voice command, a response to a prompt, or if an extended period of time elapses before a command is spoken, the session automatically cancels.

Teleprompter

See Figure 115. The teleprompter is shown when the Voice Recognition switch is pressed. The teleprompter screen shows commonly used commands, along with a line item to display more commands.

The Cursor/Select switch can be used to select a command. Speaking or selecting **MORE COMMANDS** displays a list of all commands



Figure 115. Teleprompter (typical)

Command List

If a command is not spoken or recognized while the teleprompter is displayed, the system shows a list of command categories. Speak one of the categories into the microphone, or use the Cursor/Select switch to show all commands related to a selected category.

Pick List

See Figure 116. Pick lists are presented in the following situations:

- More than one reasonable recognition of a word is available.
- Multiple choices are available.
- Navigation is attempting to refine a location.

When presented with a pick list, speak the desired line item into the microphone such as **LINE THREE**.

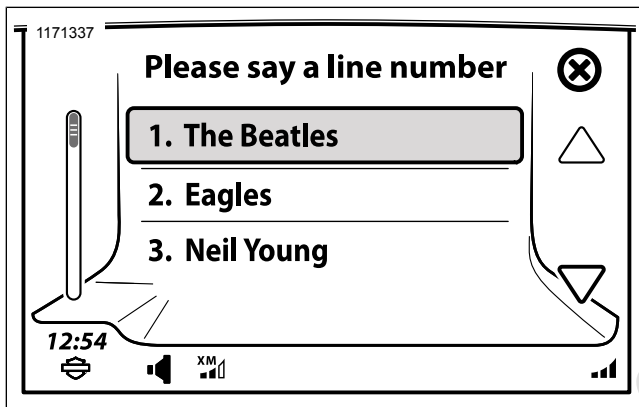

Figure 116. Voice Recognition Pick List

Prompter Responds "Pardon?"

Microphone: Speak voice commands into the microphone of the headset. Proper placement of the microphone is critical to the effectiveness of voice commands.

Speech: Speak naturally into the headset microphone. Articulate each word in a voice command. Do not pause between words. The system cannot recognize rapid speech or a raised voice level.

Numbers: Pronounce numbers as individual numerals. Speak the number 88 as "eight, eight" rather than "eighty-eight". Speak zeros as "zero" or "oh". Pronounce decimal points in frequency numbers as "point".

Voice Recognition Commands

Table 43. Voice Recognition: General Commands

COMMAND	DESCRIPTION
ALL COMMANDS	List all available voice recognition commands.
CANCEL	Cancel voice recognition session.
LINE <NUMBER>	Select line number from list.
LIST	Show list of options.
YES	Acknowledge or continue.
NO	Decline or end.

Table 44. Voice Recognition: Tuner Commands

COMMAND	DESCRIPTION
A M	Set tuner to AM band.
F M	Set tuner to FM band.
WEATHER BAND	Set tuner to weather band.
MEDIUM WAVE	Set tuner to MW band.
LONG WAVE	Set tuner to LW band.
TUNE TO <FREQUENCY>	Tunes to a specified frequency. The radio will automatically change to the appropriate band for the selected frequency. Example: When saying TUNE TO NINETY-EIGHT POINT SEVEN, the tuner will change to the FM band and tune to 98.7 MHz.
SEEK UP/SEEK DOWN	Seeks next station up or down.
NEXT PRESET/PREVIOUS PRESET	Selects next/previous preset.
STATION <NAME>	Tunes to a selected station (European region only).

Table 45. Voice Recognition: Media Commands

COMMAND	DESCRIPTION
MEDIA	Enters media mode.
PLAY <ARTIST, ALBUM or SONG>	Plays songs from the selected artist.
ARTIST <NAME>	Plays songs from the selected artist.
ALBUM <NAME>	Plays the selected album.
PLAY ALL SONGS	Plays all songs on the media device.
GENRE <NAME or LIST ALL>	Plays songs from a selected genre or lists all available genres.
NEXT TRACK	Plays next track on media device.
PLAY PLAYLIST <NAME>	Plays a selected playlist.
PREVIOUS TRACK	Plays previous track on media device.

Table 45. Voice Recognition: Media Commands

COMMAND	DESCRIPTION
SONG <NAME>	Plays the selected song.
SEARCH FOR MUSIC	Search for a song or list all songs on a device.

Table 46. Voice Recognition: Phone Commands

COMMAND	DESCRIPTION
CALL <CONTACT NAME>	Begins a phone call to a phone book contact or locally saved contact. The system prompts if the contact has more than one phone number (home, mobile, work or other).
DIAL <PHONE NUMBER>	Dials a selected phone number.
REDIAL	Dials previous phone number.

Table 47. Voice Recognition: SiriusXM Commands

COMMAND	DESCRIPTION
X M	Plays SiriusXM radio.
CHANNEL <NUMBER or NAME>	Changes to selected channel. The system automatically changes to SiriusXM when channel commands are used.
CHANNEL UP	Changes to next channel up.
CHANNEL DOWN	Changes to next channel down.
CHANNEL SCAN	Scans through the SiriusXM channels.

Table 48. Voice Recognition: Navigation Commands

COMMAND	DESCRIPTION
DESTINATION <ADDRESS>	<p>Begins a route to the selected address. This "one-shot destination" command is not available in some regions. If not supported, the system will prompt for address elements (city, state and so on) through a series of steps.</p> <p>Example: It is recommended to say the destination as one string, such as DESTINATION 400 WEST CANAL STREET MILWAUKEE WISCONSIN.</p> <p>Note: Complex street addresses with letters and numbers (such as "N23W2345 River Run Road") may not be recognized by the voice recognition system. If a destination is not recognized, enter the address using the navigation menu.</p>
FAVORITE <SAVED>	Begins a route to a previously saved destination.
FIND NEXT <POI>	<p>Provides a list of stores or brands that match the requested POI. Select an item from the pick list to begin navigation to the POI.</p> <p>Note: POI types (such as FIND NEXT GAS STATION) and brand names (such as FIND NEXT SHELL) are read from the navigation database. Not all POI names are translated by Boom! Box software into recognizable command words. Voice recognition matching can be made more difficult when the names consist of multiple words or syllables. If a particular name does not produce recognizable results, try synonyms or other variations of a POI command.</p>
SHOW MAP	Displays the navigation map.
CANCEL ROUTE GUIDANCE	Cancels the current route.
REPEAT INSTRUCTIONS	Replays the navigation instructions for the next turn.
ENTER <COUNTRY, STATE, CITY, ZIP CODE, STREET, HOUSE NUMBER>	<p>Begins entering destination information into the address screen.</p> <p>Example: When saying ENTER STATE, the prompter responds with "Say the State Name". After providing the state name, the system continues to prompt for the remaining address fields on the screen.</p>

INTERCOM

The intercom allows the rider and passenger to talk with each other through the headsets. The intercom can be operated by pressing the PTT switch or by using voice operated transmission (VOX). When voice input is picked up by the rider or passenger microphone, the intercom is automatically activated. This process is known as "breaking VOX".

The rider or passenger can initiate intercom communication. When the intercom is active, tuner and media volume are automatically reduced so the intercom can be heard through the headsets.

For privacy, the intercom is only heard through the rider and passenger headsets. It is not heard through the speakers.

Microphone sensitivity and headset volume can be adjusted. The microphone sensitivity (VOX) applies to both rider and passenger microphones. The rider and passenger headset volumes are adjusted independently.

NOTE

Some local governments prohibit or restrict the use of headset (helmet-mounted) speakers. Check with local authorities and obey all applicable laws and regulations.

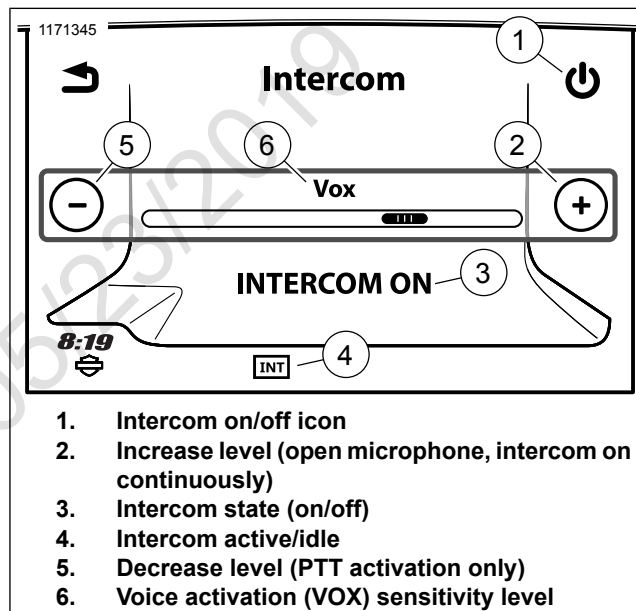

Figure 117. Intercom Screen

Turning Intercom On/Off

NOTE

If the Intercom is disabled, the selection button will not be greyed out and not selectable.

1. **Navigate:** Home > Communications > Intercom.
2. Select Intercom on/off to turn intercom **On** or **Off**. When turned on, the intercom is available for use and the intercom icon is displayed in the status bar. The intercom can be used while on any screen.

Adjusting Microphone Sensitivity: VOX

VOX sensitivity should be adjusted so the microphones break VOX at normal voice volume. The sensitivity level applies to both the rider and passenger microphones.

Adjust the sensitivity as needed if the microphone breaks VOX from unintended sounds, such as road or background noise.

1. **Navigate:** Home > Communications > Intercom.
2. While speaking into the microphone, use the controls (+ or -) to adjust the sensitivity until your normal voice volume breaks VOX. The intercom icon in the status bar should be white (active) when speaking at a normal tone.
 - a. **Raise sensitivity:** Move the level to the right. The microphone becomes more sensitive. The intercom will activate (break VOX) with quieter sounds through the microphone.

- b. **Reduce sensitivity:** Move the level to the left. The intercom will only activate (break VOX) with louder voice or sounds.
- c. **Fully open microphone:** Raising the sensitivity to the maximum level will keep the intercom microphone open continually.
- d. **PTT only:** Reducing the sensitivity to the minimum level will prevent any VOX operation. The intercom can only be activated with the PTT switch.

Speed Volume

Speed volume is applied to the intercom to compensate for engine noise, wind and road input. As the motorcycle speed increases, the sensitivity of the microphones will automatically decrease. This prevents road noise from breaking VOX. It also prevents unnecessary adjustments to the microphone sensitivity while riding.

Adjusting Intercom Volume: Rider and Passenger Headsets

1. See Figure 118. Activate the intercom (press the PTT switch or speak loud enough to break VOX).

2. Adjust the volume while the intercom is active. The intercom volume displays on the screen while the intercom is activated. Rider and passenger headset volumes are independently controlled.
 - a. **Rider:** Press the volume controls on the left handlebar.
 - b. **Passenger:** Press the VOL+/VOL- switch on the side of the Tour-Pak.

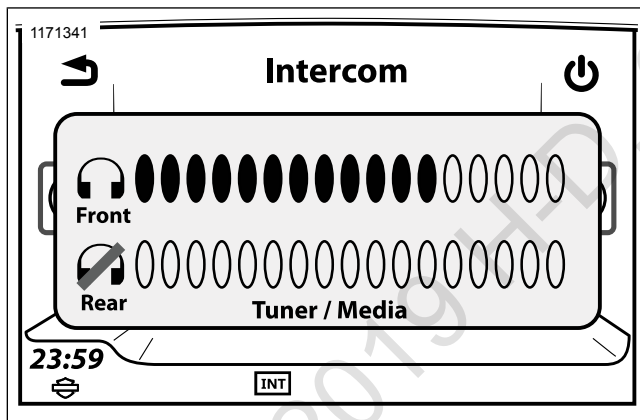

Figure 118. Intercom Volume

Operating Intercom: Voice Activation, VOX

Speak into the microphone at an adequate level to break VOX. The tuner or media volume will reduce into the background so the intercom can be heard. The intercom icon will turn white (active).

The intercom audio will be heard in the headsets. VOX activated communication is not broadcasted over the CB.

Operating Intercom: PTT Switch

1. Press and hold the PTT switch (rider or passenger) to activate the intercom. The intercom icon will turn white (active). The tuner or media volume will mute so the intercom can be heard.
2. Speak into the microphone. While the PTT switch is held, the microphones will remain active regardless of the VOX setting or sound level.

NOTE

- If the CB is turned on, pressing the PTT switch will also activate the CB. Any sound in the microphones will be shared over the current CB channel. Turn off the CB or use the voice activation (VOX) feature if there is a need to communicate privately.

- To activate the intercom with only the PTT switch (rather than VOX), reduce the VOX sensitivity to its lowest level. See *Adjusting Microphone Sensitivity: VOX*.

WHIM

NOTE

CVO vehicles come standard with the Sena 20S EVO wireless headset. Instructions are written for this particular set but the procedure is still the same when pairing other products.

Please read the Sena User's Guide for additional information pertaining to the wireless headset. Also check **Harley-Davidson.com > Owners > Infotainment** for the latest version of User's Guide and related information to Boom! Audio Bluetooth products.

Getting Started

Charge the wireless headset by connecting the supplied USB power & data cable into a computer USB port or USB wall charger. You can use any standard micro-USB cable to charge. The LED turns red while the headset is charging and turns blue when it is fully charged. It takes about 2.5 hours to be completely charged.

Powering On and Off

See Figure 119. Press the Jog Dial (1) and the Phone Button (3) at the same time to power the headset either on or off.

188 Communications

Information accurate as of January 28th, 2019. Go to <https://serviceinfo.harley-davidson.com> to check for the latest version.

When powering on the headset, press the Jog Dial and the Phone button at the same time until the blue LED (2) appears while hearing the ascending beeps. When powering off the headset, press the Jog Dial and the Phone Button at the same time until the red LED (2) appears briefly and the headset turns off completely while hearing descending beeps.

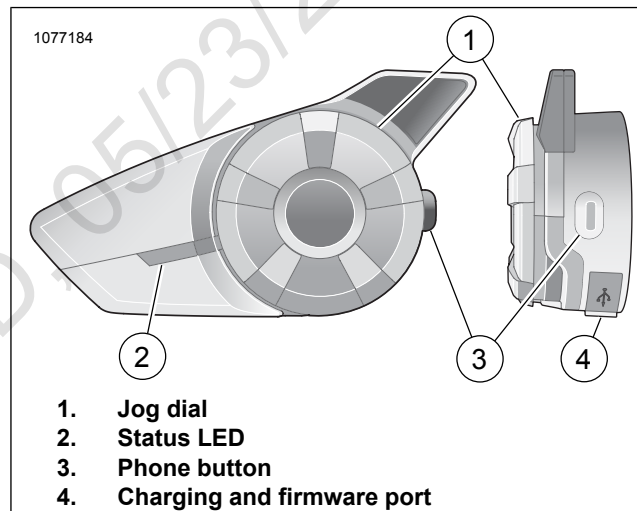

Figure 119. Boom Wireless Headset

Wireless Headset Setup

Before using the wireless headset with any Bluetooth devices for the first time, you will need to pair them together. For example, it can be paired with Bluetooth mobile phones, Bluetooth stereo devices such as MP3 players, or motorcycle specific Bluetooth GPS navigation, and with other Boom! Audio Bluetooth headsets. This pairing operation is only required once for any Bluetooth device. The headset remains paired with the devices and automatically reconnects to them when they are within range. You will hear a high tone single beep and a voice prompt when the headset connects to the paired device automatically:

When a headset is paired to the motorcycle, it will say **Your Headset is Paired, Boom Audio Connected**. After this initial pairing, every time the headset connects to the motorcycle you will hear **Boom Audio Connected**.

When a headset is paired to a phone, it will confirm the pairing by saying **Your Headset is Paired**.. After this initial pairing, every time the headset reconnects to the phone it will say **Phone Connected**.

1. Turn on wireless headset.
2. **Navigate:** Home > Setup > Wireless Headset.

NOTE

*Place headset in pairing mode before selecting **Pair Rider Headset**. Press phone button for 5 seconds until red and blue LED's alternately flash.*

3. Put **Headset** into pairing mode.
 - a. Touchscreen will display **Pairing in Process with Headset**.

NOTE

Rider's headset should be paired first followed by the passenger.

4. See Figure 120. **Select:** Pair Rider Headset.

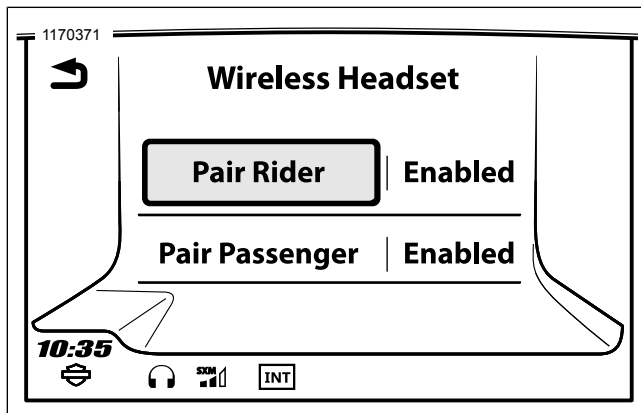

Figure 120. Pair Rider Headset

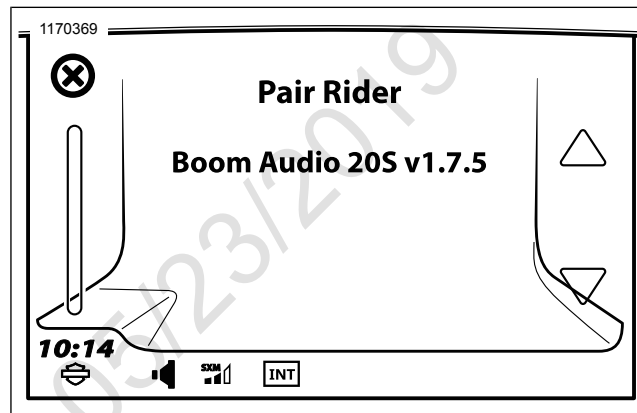

Figure 121. Place Headset Into Pairing Mode

NOTE

Harley Davidson headsets will show up as Boom Audio and the version of its software. See owner's manual of non-Harley Davidson headset products for display options.

5. See Figure 121. Confirm wireless headset display information on the touchscreen. Select the model of wireless headset to pair.

6. See Figure 122. Touchscreen will display confirmation status that the wireless headset has been Connected.

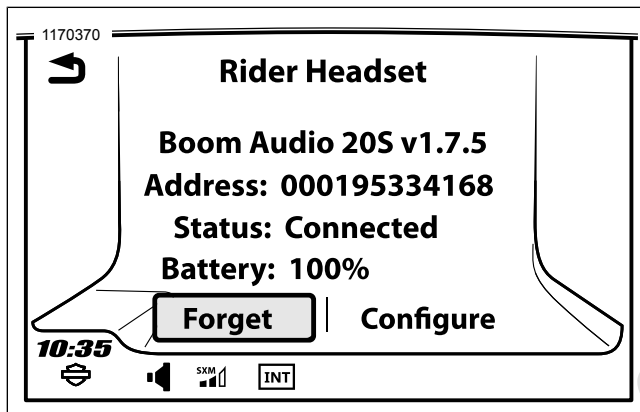

Figure 122. Paired Headset

7. Perform the same procedure for pairing the wireless headset for a passenger.

Headset to Headset Intercom Pairing

NOTE

When in pairing mode, do one device at a time in the area of the motorcycle and headset.

Please read the Sena User's Guide for information pertaining to the wireless headset to headset intercom set up and usage.

Headset Configurations

NOTE

The wireless headset must be turned on and paired with the system for the following configurations to appear on the touchscreen.

The headset configurations only affect headset performance when it is paired to a phone or other headset. They do not directly impact the performance of the headset when it is paired to the vehicle. The Sidetone setting is the only configuration option that will directly impact the headset when it is paired to a vehicle.

The 12 configuration modes can be accessed through the Boom! Box Infotainment system.

Select **Home > Setup > Wireless Headset > Manage Rider or Passenger Headset > Config** to manage headset configurations.

Smart Vol. Control: Smart Volume Control automatically changes the level of the speaker volume based on the level of the environmental noise. When it is disabled, volume is controlled manually. You can enable it by setting the sensitivity to low, medium, or high. Smart Volume Control responds to smaller environmental noises as the sensitivity level becomes higher. The default setting is disabled.

SideTone: Sidetone is the sound of your own voice as picked up by your headset's microphone and reproduced in your own ear, by your own speaker. It helps you to naturally speak at the correct level according to varying helmet noise conditions. If this feature is enabled, you can hear what you are speaking during an intercom conversation or a phone call. The default setting is disabled.

Voice Prompt: You can disable voice prompts, but the following voice prompts are always on:

- Voice prompts for configuration setting menu
- Voice prompts for battery level Indicator
- Voice prompts for factory reset
- Voice prompts for speed dial
- Voice prompts for FM radio functions

Adv. Noise Control: When Advanced Noise Control is enabled, the background noise is reduced during an intercom conversation. When it is disabled, the background noise is mixed with your voice during intercom. The default setting is enabled.

Motion Sensitivity: Motion Sensor Sensitivity determines the sensitivity when you double tap on the surface of the Boom! Audio 20S EVO to enter voice command mode. The default setting is low, but you may change it to high, or disable the feature.

VOX Phone: If this feature is enabled, you can answer incoming calls by simply saying a word loudly enough, unless you are connected to intercom. For example, when you hear a series of beeps for an incoming call, you can answer the phone by saying **Hello** or any other word loudly. However, the VOX Phone feature does not work if you are connected to the intercom. This feature is enabled from the factory but can be disabled through the configuration menu, Device Manager, or the Sena Smartphone App. If this mode is disabled, you have to tap the Jog Dial or the Phone Button to answer an incoming call.

HD Intercom: HD Intercom enhances the two-way intercom audio from normal quality to HD quality. HD Intercom will become temporarily disabled when you enter into a multi-way intercom. If this feature is disabled, the two-way intercom audio will change to normal quality. The default setting is enabled.

Audio Multitasking: Audio Multitasking allows you to have an intercom conversation while simultaneously listening to music, FM radio, or GPS instructions. The overlaid audio is played in the background with reduced volume whenever there is an intercom conversation and will return to normal volume once the conversation is finished. If this feature is disabled, any incoming or outgoing intercom will interrupt your audio channel. The default setting is enabled.

INT-Audio Sensitivity: When the Audio Multitasking setting is enabled, if you talk over the intercom while music is playing,

then the music volume will be lowered to play in the background. You can adjust the intercom sensitivity to activate this background music mode. Level 1 has the lowest sensitivity and level 10 has the highest sensitivity. The default setting is 6.

Nav. App Support: When Audio Multitasking is enabled, your smartphone's GPS application reduces in volume whenever there is an ongoing intercom conversation. To listen to your smartphone's GPS navigation clearly without this volume reduction, enable Navigation App Support. The default setting is disabled.

Eight-way Intercom: Disabling the Eight-way Intercom optimizes the intercom performance for a small group up to four participants. Enabling the Eight-way Intercom optimizes the intercom performance for a larger group up to eight participants. The default setting is disabled.

FM Station Guide: When FM Station Guide is enabled, FM station frequencies are given by voice prompts as you select preset stations. When FM Station Guide is disabled, the voice prompts on FM station frequencies will not be given as you select preset stations. The default setting is enabled.

Headset Software Version

NOTE

The Boom! Audio 20S EVO supports firmware upgrade function. Visit www.Harley-Davidson.com to check for the latest software downloads.

The information given in this topic is only informational. The exact Model/Software Version and Address will vary upon the product that is paired to the vehicle.

See Figure 122. When the wireless headset is properly paired it will confirm:

- Model/Software Version:
- Bluetooth Address:
- Status: Connected

Unpair Wireless Headset

1. **Select:** Home > Setup > Wireless Headset.
2. **Select:** Manage Rider or Passenger headset.
3. See Figure 122. **Select:** Forget. This will unpair rider or passenger wireless headset from the Boom system.

Reset Factory Headset Settings

NOTE

When performing this procedure, the link between the Boom! Infotainment system and headset will be broken. The wireless headsets must be paired again for system communications to operate properly.

1. To restore the Boom! Audio 20S EVO to factory default settings, press and hold the Phone Button for 12 seconds until the LED shows solid red and you hear double beeps. You will hear a voice prompt saying **Factory reset**.
2. Within 5 seconds, press the Jog Dial to confirm reset. The headset will be restored to factory settings and switched off automatically. You will hear a voice prompt saying **Headset reset, good-bye**.
3. If you press the Phone Button or don't press the Jog Dial within 5 seconds, the reset attempt is canceled and the headset returns to stand-by mode. You will hear a voice prompt saying **Canceled**.
4. Unpair current wireless headset(s) in Boom system. See Unpair Wireless Headset in this section.
5. Perform pairing procedure. See Wireless Headset Setup in this section.

Fault Reset

See Figure 123. When the Boom! Audio 20S EVO is not working properly or is in faulty status for any reason, you may reset by pushing the pin-hole reset button at the back of the headset main unit. Insert a paper clip into the reset pin-hole and press the reset button for a second with light pressure. The Boom! Audio 20S EVO will be switched off, and you have to turn the system back on and try again. However, this will not restore the headset to factory default settings.

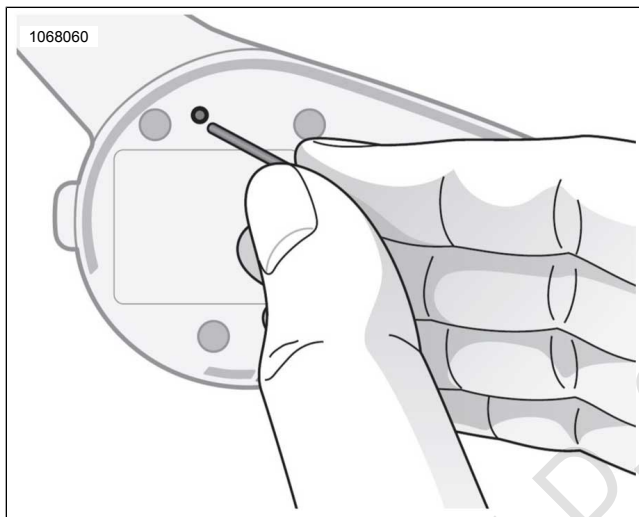

Figure 123. Fault Reset

CITIZEN BAND (CB) RADIO

⚠ WARNING

Set CB channel, squelch threshold and volume before riding to minimize adjustments on the road. Distractions can lead to loss of control, resulting in death or serious injury. (00089a)

NOTICE

Operating the CB radio without an antenna or with a broken antenna cable can result in damage to the transmitter circuitry. (00176a)

NOTICE

There are no adjustments internal to the CB transceiver chassis that can be performed without risking non-compliance with Federal Communications Commission (FCC) rules. Refer to the original equipment manufacturer for any service required during the warranty period. For transmitter service after the warranty period, refer to a certified repair service. Any frequency determining components, such as crystals, or power determining semi-conductors, etc., should only be replaced with the original component manufacturer's part or equivalent. Substitutes can result in violation of FCC rules. (00175a)

Some models in select regions have a CB module. The CB radio can be used to communicate with other CB-equipped motorcycles (or other CB users) on any of the 40 Citizen Band channels.

Regulations for CB operation, specific frequencies or power output may be unique for different regions. Check local laws and regulations before operating the CB radio. In the United

States, read **Part 95, FCC Rules and Regulations** before operating your transmitter.

Turning CB On

NOTE

If the CB is disabled, the selection button will not be greyed out and not selectable.

The CB must be turned on before using. After the CB is turned on and a channel has been selected, you can leave the CB screen and use other radio features (such as listening to tuner stations, making phone calls, using navigation features, or listening to media files). The CB remains muted but continues operating in the background. The rider and passenger can transmit or receive CB audio at any time while on any screen.

1. **Navigate:** Home > Communications > CB.
2. See Figure 124. Press the On/Off icon. The middle of the screen shows the current channel and CB On. The CB icon is displayed in the status bar while the CB remains on.

Turning CB Off

See Figure 124. On the CB screen, press the On/Off icon. The CB presets will be disabled, the middle of the screen will show CB Off and the CB icon in the status bar will turn off.

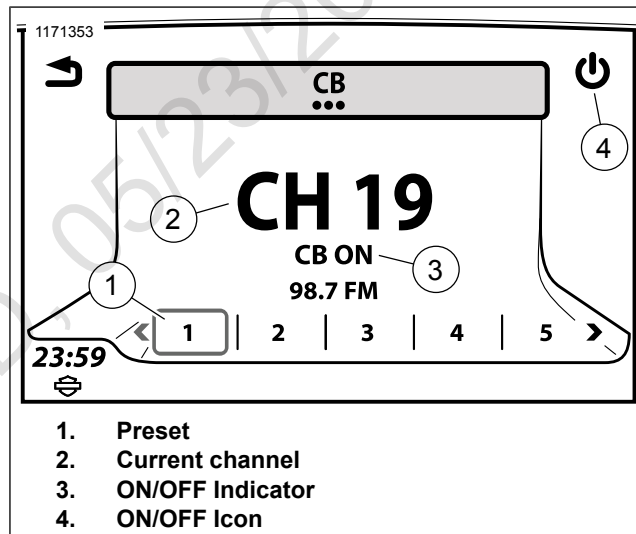

Figure 124. CB Screen

Conflicting Transmissions

CB channels are mutually shared among many users. Interruptions and conflicting transmissions from multiple users on a channel can make it difficult for your intended recipient to understand your message. To make sure that your transmission is received well, and as a courtesy to others, wait until the channel is clear before pressing the PTT switch.

If too many users are actively using a channel, try to specify another possible channel to your intended recipients so you can resume your conversation together on that channel.

For important communications, make sure that your recipient acknowledges that they have received and understand your message.

Emergency Operation: Channel 9

In the US, the FCC has reserved channel 9 for emergency or traveler assistance use only. Use of this channel should only be for issues involving personal safety, damage to property or other required assistance. Channel 9 is also reserved for emergency use in most other countries that allow Citizen Band radio.

When using this channel for emergencies or assistance, clearly identify the nature of the problem and your location. If no response is received, try other channels or find another way to get help.

Transmitting on CB

Start transmitting: While on any screen, wait until other active CB transmissions are finished and the channel is clear. Press and hold the PTT switch to begin transmitting on the current CB channel. Any sound picked up from the rider and passenger microphones will be transmitted. While the PTT switch is held, all other audio is muted, including any inbound CB messages that may be coming in. The CB Active icon will be displayed in the status bar during the transmission. See Figure 125.

Stop transmitting: Release the PTT switch to stop transmitting. The status bar will show the CB Idle icon. Audio will be resumed, and any CB audio that breaks squelch will be received.

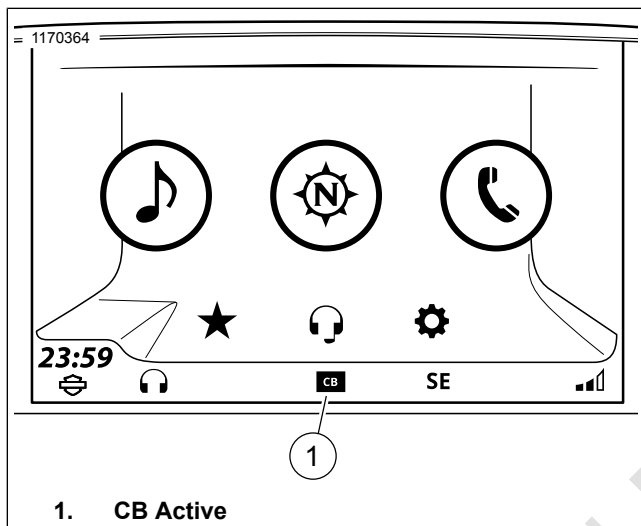

Figure 125. CB Active

Receiving CB Audio

The radio will receive inbound CB audio while on any screen. When an incoming CB signal breaks squelch, the CB audio interrupts (or mixes) with the current audio source in the radio. While CB audio is being received, the CB Active icon is displayed in the status bar.

If necessary, adjust the squelch level so noise does not break squelch, but desired CB audio is still received.

CB audio is received through the speakers or the headsets, depending on the audio routing settings. See Speaker (Page 65). Both rider and passenger headsets will receive inbound CB audio.

Tuning CB Channels

The CB radio can access all 40 channels. While on the CB screen, press the Previous/Next hand control to advance through the CB channels individually. Channels can only be changed while in the CB screen.

Refer to local regulations for any further restrictions or recommendations on local channel use. For some of the popular CB channels used, Refer to Table 49.

Table 49. CB Channels: Popular or Reserved

CHANNEL	DESCRIPTION
Channel 8	Unofficial travelers channel (Australia)
Channel 9	Reserved for emergency and traveler assistance use only (most countries)
Channel 13	Unofficial travelers channel (Greece)
Channel 15	Unofficial travelers channel (Russia)
Channel 17	North-south freeway trucker channel (US)
Channel 19	East-west freeway trucker channel (US) Unofficial travelers channel (most countries)

CB Presets

The CB screen stores six preset channels. Save your most commonly used channels as presets so they can be easily accessed. Some recommended presets include channel 9 (emergency channel) and channel 19 (unofficial travelers channel).

Setting CB preset: Tune to a CB channel. Press and hold a CB preset until the system beeps and the channel is saved.

Recalling CB preset: With the CB turned on, press the desired CB preset.

NOTE

CB channels cannot be configured as global presets or favorites.

Squelch

The squelch level determines the minimum signal strength that will unmute CB reception. When a CB signal exceeds the selected threshold, the radio will "break squelch". The current audio source (such as a radio station or media file) mutes and the CB channel is unmuted.

Adjusting squelch: See Figure 126. With the CB turned on, push down the squelch switch (SQ-) until noise and static are heard. The CB Active icon will be displayed. Then push up

the squelch switch (SQ+) one or two levels. This eliminates noise while allowing any stronger signals to break squelch.

Intermittent noise: If intermittent noise or undesired weak CB signals continue to break squelch, consider raising the squelch further. However, setting the squelch too high can prevent desired CB audio from being received.

Maximum squelch: At maximum squelch, the radio will not break squelch for any signal. All inbound CB signals are effectively muted.

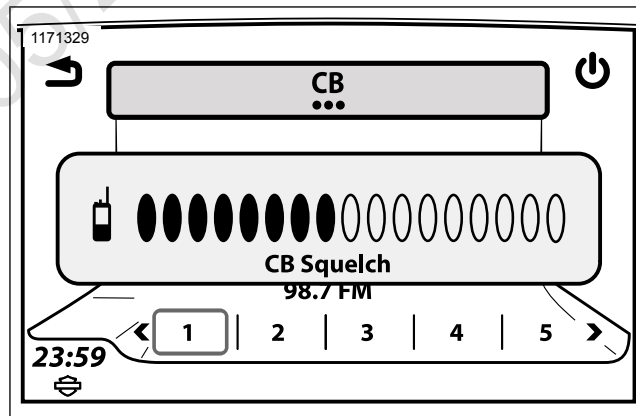

Figure 126. CB Squelch Level

CB Volume

CB Audio Routing: CB audio can be routed to the speakers or the rider/passenger headsets. See Speaker (Page 65).

Adjusting CB volume (while on CB screen): Use rider volume controls to adjust speaker or rider headset volume. Use passenger volume controls to adjust passenger headset volume.

Adjusting CB volume (while not on CB screen): See Figure 127. While CB audio is being received, use the rider or passenger volume controls. If necessary, first reduce the squelch until CB audio breaks squelch, then adjust the volume. Raise the squelch to its original level.

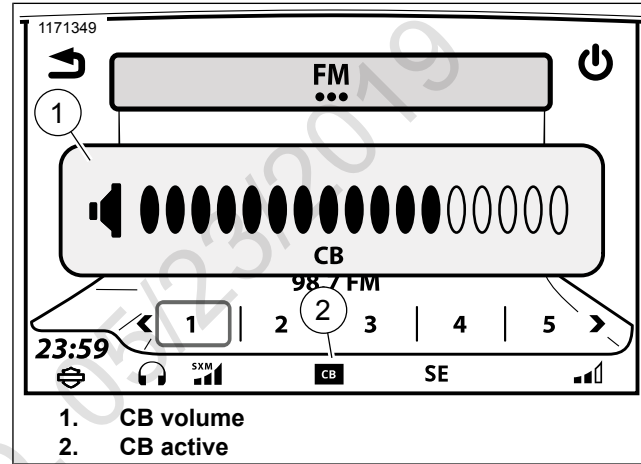

Figure 127. CB Volume

Passenger CB Operation

The passenger can also transmit over the current CB channel, adjust CB volume for the passenger headset and listen to inbound CB audio in the passenger headsets. The passenger cannot adjust speaker volume, adjust squelch or change CB channels.

Initiating CB transmission (passenger): When channel is clear, press and hold the passenger PTT switch on side of

Tour-Pak. Both the rider and passenger microphones become active. Release PTT switch when finished.

Adjusting CB volume (passenger): While on CB screen (or while CB is in operation), use UP/DN switch on side of Tour-Pak to adjust passenger headset volume. The volume switch does not affect the speakers or rider headset volume.

Factors Affecting CB Range

Adverse weather, buildings, hills and valleys can affect the maximum range for the CB radio. Degraded reception or transmission capability can also occur in tunnels or parking garages. The CB transmitter is the most powerful allowed under US federal law. However, since there is no large steel area to create a ground plane, the CB may not transmit as strongly as CBs mounted in a car or truck.

Adding an Optional CB Module

Bike-to-bike (CB) communication is standard on some vehicles in select locations. For vehicles not equipped with a CB, the optional CB accessories can be purchased at www.h-d.com/store or at an authorized Harley-Davidson dealer.

Installation of the CB module may only be allowed in particular regions. See www.h-d.com/store or your authorized Harley-Davidson dealer for fitment and requirements. Follow the instruction sheet procedures or have an authorized

Harley-Davidson dealer install the accessory. For set up and operation, use the instructions in this manual.

NOTES

© 2019 H-D, 05/23/2019

FAVORITES

The system stores up to 6 favorites. Favorites can be used to quickly access a tuner band, frequency, media device, media file, SiriusXM channel, navigation destination or phone contacts that are commonly used.

CB channels and files from a Bluetooth-connected device cannot be saved as favorites.

SETTING A FAVORITE

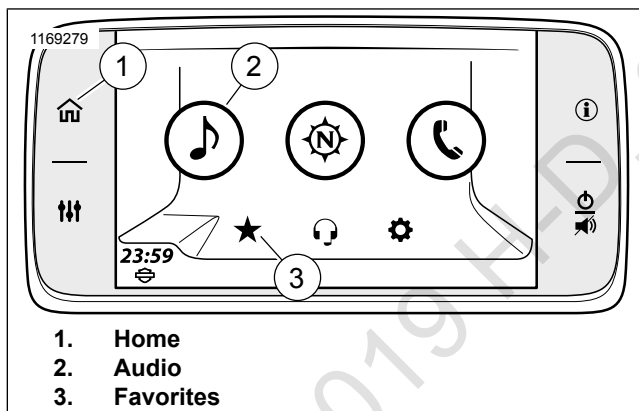

Figure 128. Home Screen

1. **Navigate:** Home > Favorites.

2. Press and hold desired preset until screen title changes to **Select a Favorite Type**.
3. **Select:** Type.
 - a. **Tuner:** Currently playing station, SXM, AM, FM or WB.
 - b. **Phone:** Recent, Contacts on Radio or Contacts on Phone. Select from list.
 - c. **Location:** Location: Recent or Saved. Select from list.
 - d. **Media:** USB. Select from list.

SELECTING A FAVORITE

If selecting a favorite that is saved from a phone or media device, the radio will not recognize the file unless the media source is connected.

1. **Navigate:** Home > Favorites.
2. **Select:** Favorite.

NOTES

© 2019 H-D, 05/23/2019

WAITING POPUP

When a database search is taking longer than the specified time threshold in the display **Searching** popup. The searching pop-up will have a minimum dwell time, after which, if the search still continues with no displayable result, a **Cancel** icon will become enabled to allow the rider to discontinue waiting for the database search.

NEXT LETTER JUMPING

The Next Letter Jump overrides normal scrolling and searches items by first letter.

The letter jump feature can be used by pressing the center button in the scroll controls. When the button highlights in gray it notifies the rider the function is enabled. Use the up and down arrows to scroll through the alphabet. If there are no items that begin with a certain letter, then that letter will not be displayed. Press center button again to disable the feature and return to normal scrolling.

Sample procedure shown:

1. See Figure 129. **Select:** Letter jump (2). Gray highlight signifies feature is enabled.
2. **Select:** Down arrow to get to letter **B**.
3. **Select:** Letter **B**.

4. First item starting with selected letter shows at the top of the list as a song selection (1).

NOTE

Holding Up or Down arrows will quickly scroll through full list when normal scrolling is enabled.

5. **Select:** Letter jump (2). The gray highlight disappears and normal scrolling is enabled. Rider may scroll through the list of songs that begin with the letter **B**.

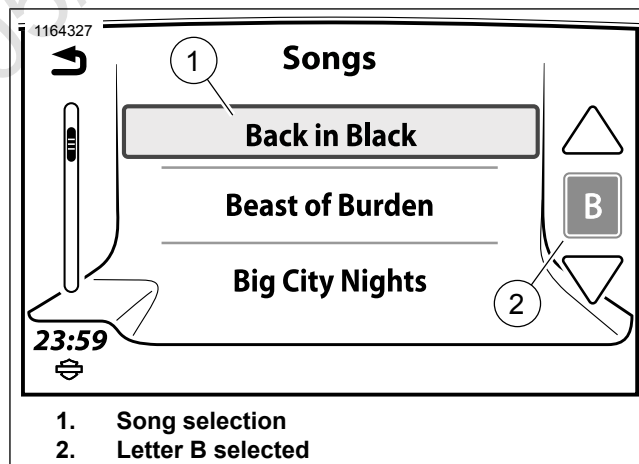

Figure 129. Next Letter Jump

POPUPS

The radio displays popup screens to explain when a feature is unavailable, display a low fuel message, indicate an incoming phone call, and so on. These screens may interrupt normal system operation. Some screens require a choice **Yes** or **No** or require confirmation **OK**. Press the icon to acknowledge the message or activate the feature.

QUICK KEYS

Quick Jump

On the left-hand control and do a long press on the Home switch (1). This displays the Quick jump screen (2).

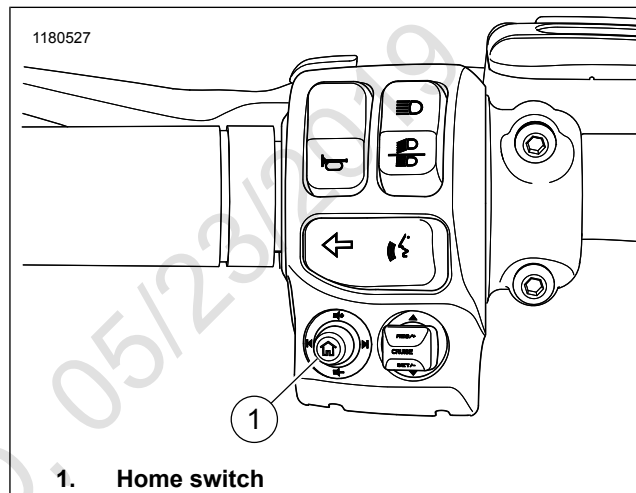

Figure 130. Left Hand Control

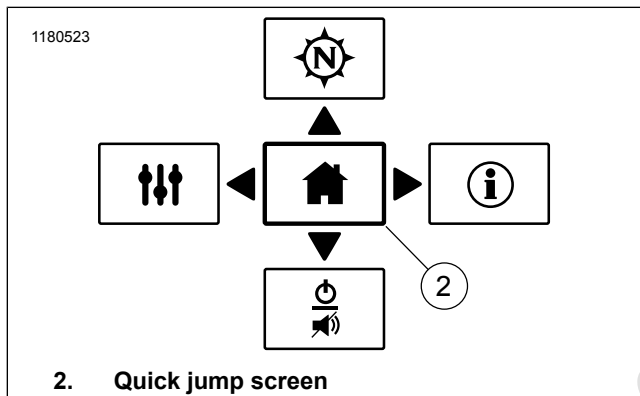

Figure 131. Quick Jump

High Contrast

High contrast day colors can be activated to enhance visibility of the screen in bright sunlight.

This feature is activated through the color settings or by holding the Back switch (1) for five seconds on the right hand control. The feature cannot be activated while the display is showing night colors.

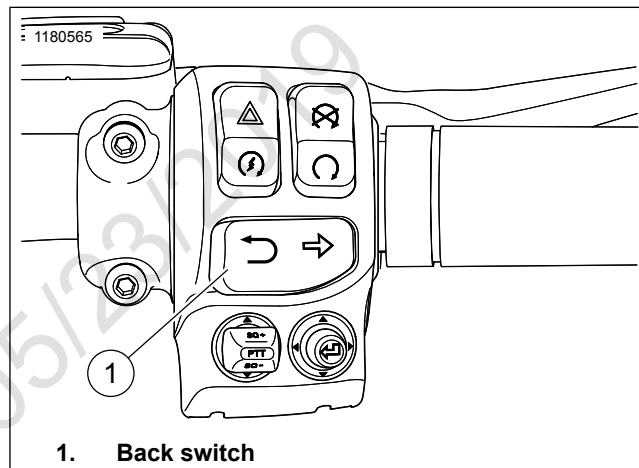

Figure 132. Right Hand Control

PROJECTION MODE

When connected and enabled, the Phone icon on the home screen will switch to the Apple CarPlay icon.

Projection mode in Apple CarPlay will be enabled or disabled via calibration to meet individual country regulation or requirements.

1. **Navigate:** Home > Setup.
2. **Select:** On or Off.

NOTES

© 2019 H-D, 05/23/2019

VEHICLE STATUS

See Figure 133. **Select:** Vehicle Status button to display various information. Press the button again to exit the screen.

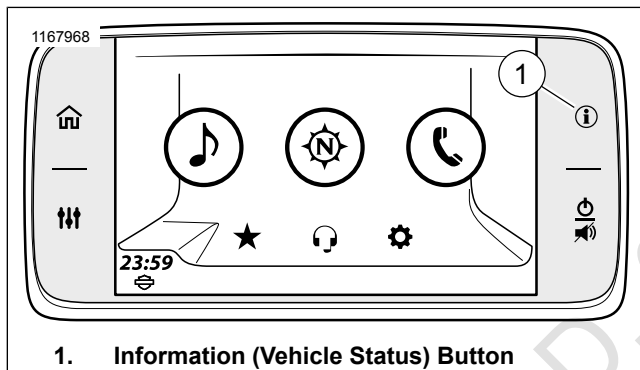

Figure 133. Information (Vehicle Status)

INFORMATION

See Figure 134. This screen provides information during an active Trip. The altitude (6), air temperature (5) and compass direction is displayed during a non-active Trip. Distance until next turn (4) is replaced with compass direction.

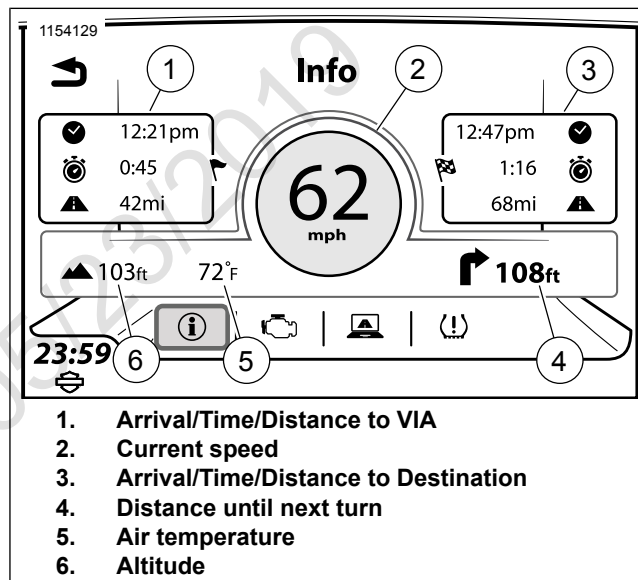

Figure 134. Trip Information Screen

ENGINE INFORMATION

This screen provides current engine information: Check Oil, Distance traveled since last service, Distance to empty fuel tank and EITMS activation notification.

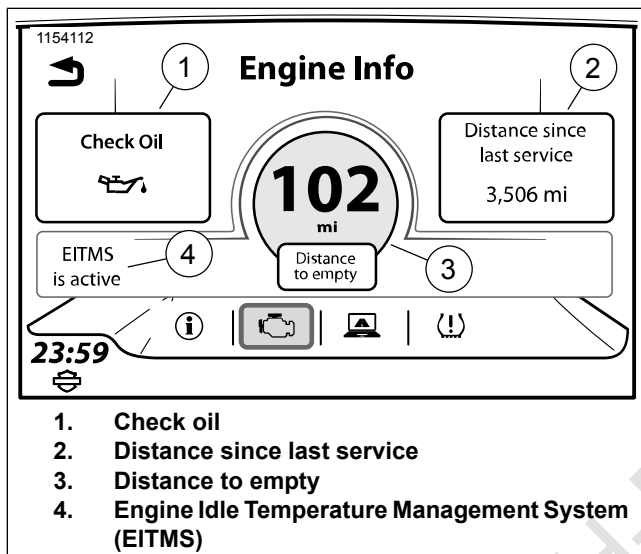

Figure 135. Engine Information Screen

Reset Last Service

Please see Harley-Davidson dealer to have the **Distance Since Last Service** odometer reset.

TIRE PRESSURE MONITORING SYSTEM (TPMS)

CVO VEHICLES ONLY

⚠ WARNING

Be sure tires are properly inflated, balanced, undamaged, and have adequate tread. Inspect your tires regularly and see a Harley-Davidson dealer for replacements. Riding with excessively worn, unbalanced, improperly inflated, overloaded or damaged tires can lead to tire failure and adversely affect stability and handling, which could result in death or serious injury. (00014b)

See Figure 136. Some vehicles have a tire pressure monitoring system (TPMS).

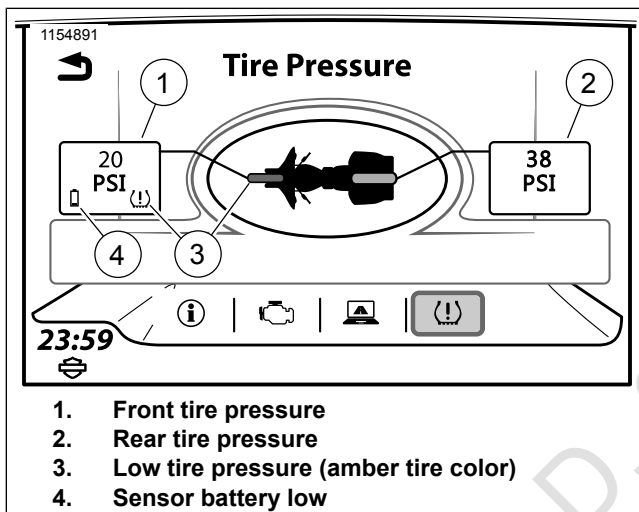

Figure 136. Tire Pressure Monitoring System (TPMS)

Front and rear tires: Each tire is shown as either white (to indicate normal tire pressure) or amber (to indicate a low tire pressure condition).

Tire pressure data: Tire pressure is displayed as psi or kPa, according to the unit settings for the radio. Dashes (--) indicate that there is no current data for the tire pressure.

Sensor battery low icon: The TPMS sensor battery is low for the indicated tire. See a Harley-Davidson dealer for service.

Low tire pressure icon: The system detects low pressure for the indicated tire. Safely stop the vehicle and use a tire pressure gauge to check the pressure of each affected tire. Inflate the tires according to specifications in the vehicle owner's manual or as specified on the label on the frame downtube.

High tire pressure icon: The system displays **HIGH** for the corresponding tire pressure on the TPMS screen rather than a numeric pressure value. Safely stop the vehicle and use a tire pressure gauge to check the pressure of each affected tire. Deflate the tire according to specifications in the vehicle owner's manual or as specified on the label on the frame downtube.

Low Tire Pressure Alert

See Figure 137. An alert is displayed when a low tire pressure condition has been detected.

Search for fuel station: For vehicles with navigation, the radio will prompt to navigate to a nearby fuel station. Select **Yes** to display a list of nearby fuel stations.

Details: Displays the TPMS screen.

An alert will be displayed only once for each tire. Turn off and restart the motorcycle to reset the alert feature.

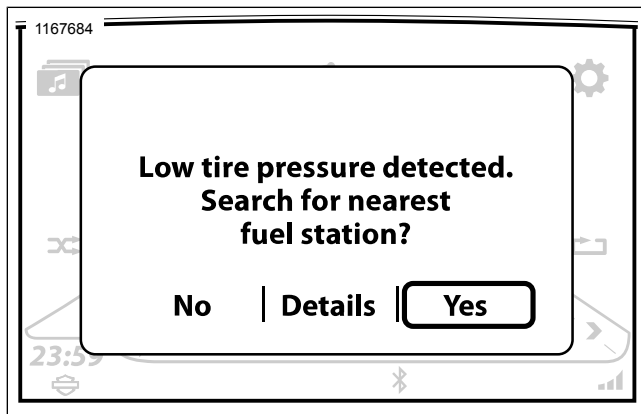

Figure 137. Low Tire Pressure Alert

TRIP SUMMARY

This screen summarizes a current trip (average speed, distance traveled, fuel used, start and end times and length of time).

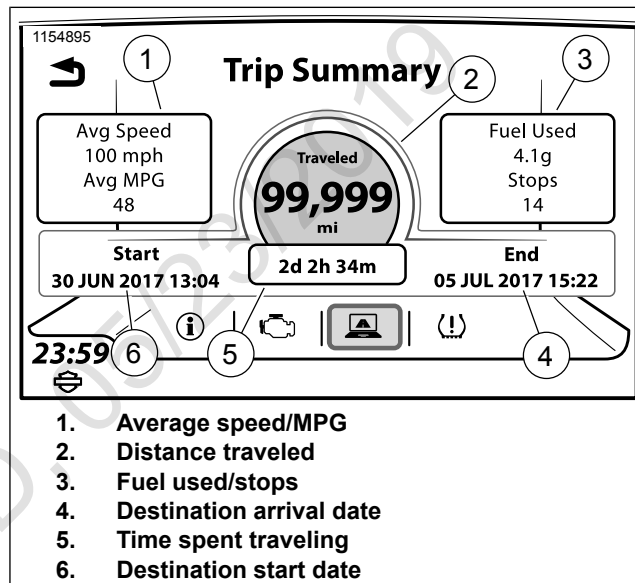

Figure 138. Trip Summary Screen

WHAT EVERY RESPONSIBLE CITIZENS BAND (CB) STATION OPERATOR SHOULD KNOW AS PREPARED BY THE FEDERAL COMMUNICATIONS COMMISSION, WASHINGTON, D.C.

Subpart D-Citizens Band (CB) Radio Service General Provisions

Sec. 95.401 (CB Rule 1) What is the Citizens Band Radio Services?

The Citizens Band (CB) Radio Service is a private, two-way, short-distance voice communications service for personal or business activities of the general public. The CB Radio Service may also be used for voice paging.

Sec. 95.401 (CB Rule 2) How do I use these rules?

(a) You must comply with these rules (See CB Rule 21 Sec. 95.421, for the penalties for violations) when you operate a station in the CB Service from:

1. Within or over the territorial limits of places where radio services are regulated by the FCC (see CB Rule 5, Sec. 95.405);
2. Aboard any vessel or aircraft registered in the United States; or

3. Aboard any unregistered vessel or aircraft owned or operated by a United States citizen or company.

(b) Your CB station must comply with technical rules found in subpart E of part 95.

(c) Where the rules use the word "you", "you" means a person operating a CB station.

(d) Where the rules use the word "person," the rules are concerned with an individual, a corporation, a partnership, an association, a joint stock company, a trust, a state, territorial or local government unit, or other legal entity.

(e) Where the rules use the term "FCC", that means the Federal Communications Commission.

(f) Where the rules use the term "CB station", that means a radio station transmitting in the CB Radio Service.

Sec. 95.403 (CB Rule 3) Am I eligible to operate a CB station?

You are authorized to operate a CB station unless:

(a) You are a foreign government, a representative of a foreign government, or a federal government agency; or

(b) The FCC has issued a cease and desist order to you, and the order is still in effect.

Sec. 95.404 (CB Rule 4) Do I need a license?

You do not need an individual license to operate a CB station. You are authorized by this rule to operate your CB station in accordance with the rules in this subpart.

Sec. 95.405 (CB Rule 5) Where may I operate my CB station?

You are authorized to operate your CB station from:

(a) Within or over any area of the world where radio services are regulated by the FCC. Those areas are within the territorial limits of:

1. The fifty United States.
2. The District of Columbia.

Caribbean Insular areas:

3. Commonwealth of Puerto Rico.
4. Navassa Island.
5. United States Virgin Islands (50 islets and cays).

Pacific Insular areas:

6. American Samoa (seven islands).
7. Baker Island.
8. Commonwealth of Northern Mariana Islands.
9. Guam Island.

10. Howland Island
11. Jarvis Island.
12. Johnston Island (Islets East, Johnston, North and Sand).
13. Kingman Reef.
14. Midway Island (Islets Eastern and Sand).
15. Palmyra Island (more than 50 islets).
16. Wake Island (Islets Peale, Wake and Wilkes).

(b) Any other area of the world, except within the territorial limits of areas where radio services are regulated by - An agency of the United States other than the FCC. (You are subject to its rules.) Any foreign government. (You are subject to its rules.)

(c) An aircraft or ship, with the permission of the captain, within or over any area of the world where radio services are regulated by the FCC or upon or over international waters. You must operate your CB station according to any applicable treaty to which the United States is a party.

(d) Anyone intending to operate a CB station on the islands of Puerto Rico, Desecheo, Mona, Vieques, and Culebra in a manner that could pose an interference threat to the Arecibo Observatory shall notify the Interference Office, Arecibo Observatory, Post Office Box 995, Arecibo, Puerto Rico 00613, in writing or electronically, of the location of the unit. Operators may wish to consult interference guidelines, which

will be provided by Cornell University. Operators who choose to transmit information electronically should e-mail to: prcz@naic.edu.

1. The notification to the Interference Office, Arecibo Observatory shall be made 45 days prior to commencing operation of the unit. The notification shall state the geographical coordinates of the unit.
2. After receipt of such notifications, the Commission will allow the Arecibo Observatory a period of 20 days for comments or objections. The operator will be required to make reasonable efforts in order to resolve or mitigate any potential interference problem with the Arecibo Observatory. If the Commission determines that an operator has satisfied its responsibility to make reasonable efforts to protect the Observatory from interference, the unit may be allowed to operate.

Sec. 95.406 (CB Rule 6) Are there any special restrictions on the location of my CB station?

- (a) If your CB station is located on premises controlled by the Department of Defense you may be required to comply with additional regulations imposed by the commanding officer of the installation.
- (b) If your CB station will be constructed on an environmentally sensitive site, or will be operated in such a manner as to raise environmental problems, under Sec. 1.1307 of this chapter,

you must provide an environmental assessment, as set forth in Sec. 1.1311 of this chapter, and undergo the environmental review, Sec. 1.1312 of this chapter, before commencement of construction.

How to Operate a CB Station

Sec. 95.407 (CB Rule 7) On what channels may I operate?

(a) Your CB station may transmit only on the following channels (frequencies):

Channel.....	Frequency (megahertz - MHz)
1.....	26.965
2.....	26.975
3.....	26.985
4.....	27.005
5.....	27.015
6.....	27.025
7.....	27.035
8.....	27.055
9.....	*27.065
10.....	27.075
11.....	27.085
12.....	27.105
13.....	27.115
14.....	27.125
15.....	27.135
16.....	27.155
17.....	27.165
18.....	27.175
19.....	27.185
20.....	27.205
21.....	27.215
22.....	27.225
23.....	27.255
24.....	27.235
25.....	27.245
26.....	27.265
27.....	27.275
28.....	27.285
29.....	27.295
30.....	27.305

31.....	27.315	32.....	27.325
33.....	27.335	34.....	27.345
35.....	27.355	36.....	27.365
37.....	27.375	38.....	27.385
39.....	27.395	40.....	27.405

.....*See paragraph (b) of this section.....

(b) Channel 9 may be used only for emergency communications or for traveler assistance.

(c) You must, at all times and on all channels, give priority to emergency communication messages concerning the immediate safety of life or the immediate protection of property.

(d) You may use any channel for emergency communications or for traveler assistance.

(e) You must share each channel with other users.

(f) The FCC will not assign any channel for the private or exclusive use of any particular CB station or group of stations.

(g) The FCC will not assign any channel for the private or exclusive use of CB stations transmitting single sideband or AM.

Sec. 95.408 (CB Rule 8) How high may I put my antenna?

(a) Antenna means the radiating system (for transmitting, receiving or both) and the structure holding it up (tower, pole or mast). It also means everything else attached to the radiating system and the structure.

(b) If your antenna is mounted on a hand-held portable unit, none of the following limitations apply.

(c) If your antenna is installed at a fixed location, it (whether receiving, transmitting or both) must comply with either one of the following:

1. The highest point must not be more than 6.10 meters (20 feet) higher than the highest point of the building or tree on which it is mounted; or
2. The highest point must not be more than 18.3 meters (60 feet) above the ground.

(d) If your CB station is located near an airport, and if your antenna structure is more than 6.1 meters (20 feet) high, you may have to obey additional restrictions. The highest point of your antenna must not exceed one meter above the airport elevation for every hundred meters of distance from the nearest point of the nearest airport runway. Differences in ground elevation between your antenna and the airport runway may complicate this formula. If your CB station is near an airport, you may contact the nearest FCC field office for a worksheet to help you figure the maximum allowable height of your antenna. Consult part 17 of the FCC's Rules for more

information. Warning: Installation and removal of CB station antennas near powerlines is dangerous. For your safety, follow the installation directions included with your antenna.

Sec. 95.409 (CB Rule 9) What equipment may I use at my CB station?

(a) You must use an FCC certificated CB transmitter at your CB station. You can identify an FCC certificated transmitter by the certification label placed on it by the manufacturer. You may examine a list of certificated equipment at any FCC Field Office or at FCC Headquarters. Use of a transmitter which is not FCC certificated voids your authority to operate the station.

(b) You must not make, or have made, any internal modification to a certificated CB transmitter. (See CB Rule 25, Sec. 95.425). Any internal modification to a certificated CB transmitter cancels the certification, and use of such a transmitter voids your authority to operate the station.

Sec. 95.410 (CB Rule 10) How much power may I use?

(a) Your CB station transmitter power output must not exceed the following values under any conditions: AM (A3)- 4 watts (carrier power) SSB- 12 watts (peak envelope power)

(b) If you need more information about the power rule, see the technical rules in subpart E of part 95.

(c) Use of a transmitter which has carrier or peak envelope power in excess of that authorized voids your authority to operate the station.

Sec. 95.411 (CB Rule 11) May I use power amplifiers?

(a) You may not attach the following items (power amplifiers) to your certificated CB transmitter in any way:

1. External radio frequency (RF) power amplifiers (sometimes called linears or linear amplifiers); or
2. Any other devices which, when used with a radio transmitter as a signal source, are capable of amplifying the signal.

(b) There are no exceptions to this rule and use of a power amplifier voids your authority to operate the station.

(c) The FCC will presume you have used a linear or other external RF power amplifier if:

1. It is in your possession or on your premises; and
2. There is other evidence that you have operated your CB station with more power than allowed by CB Rule 10, Sec. 95.410.

(d) Paragraph (c) of this section does not apply if you hold a license in another radio service which allows you to operate an external RF power amplifier.

Sec. 95.412 (CB Rule 12) What communications may be transmitted?

(a) You may use your CB station to transmit two-way plain language communications. Two-way plain language communications are communications without codes or coded messages. Operating signals such as 'ten codes' are not considered codes or coded messages. You may transmit two-way plain language communications only to other CB stations, to units of your own CB station or to authorized government stations on CB frequencies about-

1. Your personal or business activities or those of members of your immediate family living in your household;
2. Emergencies (see CB Rule 18, Sec. 95.418);
3. Traveler assistance (see CB Rule 18, Sec. 95.418); or
4. Civil defense activities in connection with official tests or drills conducted by, or actual emergencies announced by, the civil defense agency with authority over the area in which your station is located.

(b) You may use your CB station to transmit a tone signal only when the signal is used to make contact or to continue communications. (Examples of circuits using these signals are tone operated squelch and selective calling circuits.) If the signal is an audible tone, it must last no longer than 15 seconds at one time. If the signal is a subaudible tone, it may be transmitted continuously only as long as you are talking.

(c) You may use your CB station to transmit one-way communications (messages which are not intended to establish communications between two or more particular CB stations) only for emergency communications, traveler assistance, brief tests (radio checks) or voice paging.

Sec. 95.413 (CB Rule 13) What communications are prohibited?

(a) You must not use a CB station:

1. In connection with any activity which is against federal, state or local law;
2. To transmit obscene, indecent or profane words, language or meaning;
3. To interfere intentionally with the communications of another CB station;
4. To transmit one-way communications, except for emergency communications, traveler assistance, brief tests (radio checks), or voice paging;
5. To advertise or solicit the sale of any goods or services;
6. To transmit music, whistling, sound effects or any material to amuse or entertain;
7. To transmit any sound effect solely to attract attention;

8. To transmit the word "MAYDAY" or any other international distress signal, except when your station is located in a ship, aircraft or other vehicle which is threatened by grave and imminent danger and you are requesting immediate assistance;
9. To communicate with, or attempt to communicate with, any CB station more than 250 kilometers (155.3 miles) away;
10. To advertise a political candidate or political campaign; (you may use your CB radio for the business or organizational aspects of a campaign, if you follow all other applicable rules);
11. To communicate with stations in other countries, except General Radio Service stations in Canada; or
12. To transmit a false or deceptive communication.

(b) You must not use a CB station to transmit communications for live or delayed rebroadcast on a radio or television broadcast station. You may use your CB station to gather news items or to prepare programs.

Sec. 95.414 (CB Rule 14) May I be paid to use my CB station?

(a) You may not accept direct or indirect payment for transmitting with a CB station.

(b) You may use a CB station to help you provide a service, and be paid for that service, as long as you are paid only for the service and not for the actual use of the CB station.

Sec. 95.415 (CB Rule 15) Who is responsible for communications I make?

You are responsible for all communications which are made by you from a CB station.

Sec 95.416 (CB Rule 16) Do I have to limit the length of my communications?

(a) You must limit your CB communications to the minimum practical time.

(b) If you are communicating with another CB station or stations, you, and the stations communicating with you, must limit each of your conversations to no more than five continuous minutes.

(c) At the end of your conversation, you, and the stations communicating with you, must not transmit again for at least one minute.

Sec. 95.417 (CB Rule 17) Do I identify my CB communications?

(a) You need not identify your CB communications.

(b) [You are encouraged to identify your CB communications by any of the following means:

1. Previously assigned CB call sign;
2. K prefix followed by operator initials and residence zip code;
3. Name; or
4. Organizational description including name and any applicable operator unit number.]

(c) [You are encouraged to use your "handle" only in conjunction with the methods of identification listed in paragraph (b) of this section.]

Sec. 95.418 (CB Rule 18) How do I use my CB station in an emergency to assist a traveler?>

- (a) You must at all times and on all channels, give priority to emergency communications.
- (b) When you are directly participating in emergency communications, you do not have to comply with the rule about length of transmissions (CB Rule 16, Sec. 95.416). You must obey all other rules.
- (c) You may use your CB station for communications necessary to assist a traveler to reach a destination or to receive necessary services. When you are using your CB station to assist a traveler, you do not have to obey the rule about length of transmissions (CB Rule 16, Sec. 95.416). You must obey all other rules.

(d) You may use your CB station to transmit one-way communications concerning highway conditions to assist travelers.

Sec. 95.419 (CB Rule 19) May I operate my CB station transmitter by remote control?

(a) You may not operate a CB station transmitter by radio remote control.

(b) You may operate a CB transmitter by wireline remote control if you obtain specific approval in writing from the FCC. To obtain FCC approval, you must show why you need to operate your station by wireline remote control. If you receive FCC approval, you must keep the approval as part of your station records. See CB Rule 27, Sec. 95.427.

(c) Remote control means operation of a CB transmitter from any place other than the location of the CB transmitter. Direct mechanical control or direct electrical control by wire from some point on the same premises, craft or vehicle as the CB transmitter is not considered remote control.

Sec. 95.420 (CB Rule 20) May I connect my CB station transmitter to a telephone?

(a) You may connect your CB station transmitter to a telephone if you comply with all of the following:

1. You or someone else must be present at your CB station and must-

- (i) Manually make the connection (the connection must not be made by remote control);
- (ii) Supervise the operation of the transmitter during the connection;
- (iii) Listen to each communication during the connection; and
- (iv) Stop all communications if there are operations in violation of these rules.

- 2. Each communication during the telephone connection must comply with all of these rules.
- 3. You must obey any restriction that the telephone company places on the connection of a CB transmitter to a telephone.

(b) The CB transmitter you connect to a telephone must not be shared with any other CB station.

(c) If you connect your CB transmitter to a telephone, you must use a phone patch device with has been registered with the FCC.

Other Things You Need to Know

Sec. 95.421 (CB Rule 21) What are the penalties for violating these rules?

(a) If the FCC finds that you have willfully or repeatedly violated the Communications Act or the FCC Rules, you may

have to pay as much as \$10,000 for each violation, up to a total of \$75,000. (See section 503(b) of the Communications Act.)

(b) If the FCC finds that you have violated any section of the Communications Act or the FCC Rules, you may be ordered to stop whatever action caused the violation. (See section 312(b) of the Communications Act.)

(c) If a Federal court finds that you have willfully and knowingly violated any FCC Rule, you may be fined up to \$500 for each day you committed the violation. (See section 502 of the Communications Act.)

(d) If a Federal court finds that you have willfully and knowingly violated any provision of the Communications Act, you may be fined up to \$10,000 or you may be imprisoned for one year, or both. (See section 501 of the Communications Act.)

Sec. 95.422 (CB Rule 22) How do I answer correspondence from the FCC?

(a) If it appears to the FCC that you have violated the Communications Act or these rules, the FCC may send you a discrepancy notice.

(b) Within the time period stated in the notice, you must answer with:

- 1. A complete written statement about the apparent discrepancy;

2. A complete written statement about any action you have taken to correct the apparent violation and to prevent it from happening again; and
3. The name of the person operating at the time of the apparent violation.

(c) If the FCC sends you a letter asking you questions about your CB radio station or its operation, you must answer each of the questions with a complete written statement within the time period stated in the letter.

(d) You must not shorten your answer by references to other communications or notices.

(e) You must send your answer to the FCC office which sent you the notice.

(f) You must keep a copy of your answer in your station records. (See CB Rule 27, Sec. 95.427.)

Sec. 95.423 (CB Rule 23) What must I do if the FCC tells me that my CB station is causing interference?

(a) If the FCC tells you that your CB station is causing interference for technical reasons you must follow all instructions in the official FCC notice. (This notice may require you to have technical adjustments made to your equipment.)

(b) You must comply with any restricted hours of CB station operation which may be included in the official notice.

Sec. 95.424 (CB Rule 24) How do I have my CB station transmitter serviced?

(a) You may adjust an antenna to your CB transmitter and you may make radio checks. (A radio check means a one way transmission for a short time in order to test the transmitter.)

(b) You are responsible for the proper operation of the station at all times and are expected to provide for observations, servicing and maintenance as often as may be necessary to ensure proper operation. You must have all internal repairs or internal adjustments to your CB transmitter made in accordance with the Technical Regulations (see subpart E). The internal repairs or internal adjustments should be performed by or under the immediate supervision and responsibility of a person certified as technically qualified to perform transmitter maintenance and repair duties in the private land mobile services and fixed services by an organization or committee representative of users in those services.

(c) Except as provided in paragraph (d) of this section, each internal repair and each internal adjustment of a CB transmitter in which signals are transmitted must be made using a nonradiating ("dummy") antenna.

(d) Brief test signals (signals not longer than one minute during any five minute period) using a radiating antenna may be transmitted in order to:

1. Adjust an antenna to a transmitter;
2. Detect or measure radiation of energy other than the intended signal; or
3. Tune a receiver to your CB transmitter.

Sec. 95.425 (CB Rule 25) May I make any changes to my CB station transmitter?

(a) You must not make or have any one else make any internal modification to your CB transmitter.

(b) Internal modification does not include:

1. Repair or servicing of a CB station transmitter (see CB Rule 24, Sec. 95.424); or
2. Changing plug-in modules which were certificated as part of your CB transmitter.
3. You must not operate a CB transmitter which has been modified by anyone in any way, including modification to operate on unauthorized frequencies or with illegal power. (See CB Rules 9 and 11, Secs. 95.409 and 95.411.)

Sec. 95.426 (CB Rule 26) Do I have to make my CB station available for inspection?

(a) If an authorized FCC representative requests to inspect your CB station, you must make your CB station and records available for inspection.

(b) A CB station includes all of the radio equipment you use.

Sec. 95.427 (CB Rule 27) What are my station records?

Your station records include the following documents, as applicable.

(a) A copy of each response to an FCC violation notice or an FCC letter. (See CB Rule 22, Sec. 95.422.)

(b) Each written permission received from the FCC. (See CB Rule 19, Sec. 95.419.)

Sec. 95.428 (CB Rule 28) How do I contact the FCC?

(a) FCC National Call Center at 1-888-225-5322.

(b) FCC World Wide Web homepage: <http://www.fcc.gov>.

(c) In writing, to FCC, Attention: CB, 1270 Fairfield Road, Gettysburg, PA 17325-7245.

Source: 48 FR 24894, June 3, 1983, unless otherwise noted.

NOTES

© 2019 H-D, 05/23/2019

2019 LIMITED RADIO WARRANTY

Harley-Davidson warrants that your Harley-Davidson radio will be free from factory defects in factory materials and workmanship, under normal use and service, for a period of twenty-four (24) months starting from the earlier of (a) the date of initial retail purchase of the motorcycle on which the radio is installed, or (b) the third anniversary of the last day of the model year of the motorcycle on which the radio is installed. Any unexpired portion of this limited warranty will be transferred to subsequent owner(s), upon the resale of the motorcycle during the limited warranty period. If the motorcycle was used as a demonstrator or company motorcycle, then the limited warranty period may have started and/or expired prior to the initial retail sale. See an authorized Harley-Davidson Dealer for details.

This limited warranty does not cover defects or damage due to abuse, misuse or improper installation, or any radio on a motorcycle which has been registered with Harley-Davidson as a collector's vehicle. Radios with a touchscreen have a replaceable protective film. Damage to the radio due to use without this screen protector is not covered under warranty. The screen protector itself is a serviceable wear part which can be purchased at an authorized Harley-Davidson dealer. Wear or subsequent damage to the screen protector is not covered under warranty. Also, the limited warranty does not cover syncing issues or an improper functioning radio caused by an incompatible phone or other media storage device (MP3,

jump drive, etc.). See an authorized Harley-Davidson dealer for details. Use of aftermarket parts may void all or parts of your limited warranty.

This limited warranty does not cover repairs under certain conditions. Examples include:

- Loss of personal media, software or data.
- Failure to provide proper installation environment.
- Damage caused by abnormal use, unauthorized modification, computer viruses, or installation of unauthorized software, peripherals and attachments; unauthorized, unapproved or incompatible devices or upgrades; or malfunction of a mobile phone or digital media device, including inadequate signal reception by the external antenna, viruses or other software problems.

To obtain warranty service, return your motorcycle with sound system intact, at your expense, within the limited warranty period to an authorized Harley-Davidson dealer. Authorized Harley-Davidson dealers should be able to provide warranty service during normal business hours depending upon the workload of the authorized dealer's service department and the availability of necessary parts.

The remedy for breach of this warranty is expressly limited to the repair or replacement (**which may include a refurbished replacement radio**), without charge for parts and labor, of any part that proves to be defective, AND DOES

Limited Radio Warranty 225

Information accurate as of January 28th, 2019. Go to <https://serviceinfo.harley-davidson.com> to check for the latest version.

NOT EXTEND TO LIABILITY FOR CONSEQUENTIAL DAMAGES, COSTS OR EXPENSES, INCLUDING LOSS OF TIME, INCONVENIENCE, COMMERCIAL LOSS, OR LOSS OF USE OF THE VEHICLE, RESULTING FROM ANY PART THAT PROVES TO BE DEFECTIVE.

THERE IS NO OTHER EXPRESS WARRANTY ON THE RADIO. ANY IMPLIED WARRANTY RELATING TO THIS RADIO, INCLUDING WARRANTIES OF MERCHANTABILITY OR FITNESS FOR A PARTICULAR PURPOSE, IS EXPRESSLY LIMITED TO THE DURATION OF THIS LIMITED WARRANTY.

TO THE FULLEST EXTENT ALLOWED BY LAW, HARLEY-DAVIDSON AND ITS AUTHORIZED DEALERS SHALL NOT BE LIABLE FOR LOSS OF TIME, INCONVENIENCE, LOSS OF MOTORCYCLE USE, COMMERCIAL LOSS OR ANY OTHER INCIDENTAL OR CONSEQUENTIAL DAMAGES.

Some states do not allow the exclusion or limitation of incidental or consequential damages, so the above limitation or exclusion may not apply to you.

Other Rights

This warranty gives you specific legal rights, and you may also have other rights which vary from state to state.

226 Limited Radio Warranty

Information accurate as of January 28th, 2019. Go to <https://serviceinfo.harley-davidson.com> to check for the latest version.

2019 AUSTRALIA/NEW ZEALAND LIMITED RADIO WARRANTY

Your Consumer Rights

The benefits given to you under this H-D Radio Warranty are additional to, and do not detract from, other rights and remedies that you may have in respect of the radio or its installation under Australian and New Zealand laws, including consumer protection laws.

In Australia, our goods come with guarantees that cannot be excluded under the Australian Consumer Law. You are entitled to a replacement or refund for a major failure and compensation for any other reasonably foreseeable loss or damage. You are also entitled to have the goods repaired or replaced if the goods fail to be of acceptable quality and the failure does not amount to a major failure.

In New Zealand, our goods also come with guarantees that cannot be excluded under the New Zealand Consumer Guarantees Act.

Warranty

This warranty is provided by Harley-Davidson Motor Company P.O. Box 653, Milwaukee, Wisconsin 53201, U.S.A, phone: +1 (414 343-4056) ("Harley-Davidson").

Harley-Davidson warrants that an authorised Harley-Davidson dealer will repair or replace your Harley-Davidson radio if it is found to be defective in factory materials or workmanship, under normal use and service, during the warranty period set out below.

Such repair or replacement will be Harley-Davidson's sole obligation and your sole remedy under this H-D Radio Warranty, however you may have other rights under Australian and New Zealand laws, as described above.

Note that goods presented for repair may be replaced by refurbished goods of the same type rather than being repaired. Refurbished parts may be used to repair goods.

Warranty Period

The warranty period is a period of twenty-four (24) months starting from the earlier of:

- (a) the date of delivery of the motorcycle on which the radio is installed by an authorised Harley-Davidson dealer to the first retail purchaser; or
- (b) the third anniversary of the last day of the model year of the motorcycle on which the radio is installed (if not sold to a retail purchaser before that date).

Any unexpired portion of this H-D Radio Warranty will be transferred to subsequent owners, upon the resale of the motorcycle during the limited warranty period. See the

Limited Radio Warranty (Australia) 227

Information accurate as of January 28th, 2019. Go to <https://serviceinfo.harley-davidson.com> to check for the latest version.

OWNER CONTACT INFORMATION section of this Owner's Manual for information regarding notification of ownership changes.

Note: If the motorcycle was used as a demonstrator or company motorcycle, then the warranty period may have started and/or expired prior to the initial retail sale. See an authorised Harley-Davidson dealer for details.

Exclusions

This H-D Radio Warranty does not cover defects or damage due to abuse, misuse or improper installation, or any radio on a motorcycle which has been registered with Harley-Davidson as a collector's vehicle. Radios with a touchscreen have a replaceable protective film. Damage to the radio due to use without this screen protector is not covered under warranty. The screen protector itself is a serviceable wear part which can be purchased at an authorized Harley-Davidson dealer. Wear or subsequent damage to the screen protector is not covered under warranty. Also, the limited warranty does not cover syncing issues or an improper functioning radio caused by an incompatible phone or other media storage device (MP3, jump drive, etc.). See an authorised Harley-Davidson dealer for details.

Obtaining Warranty Service

To obtain warranty service, return your motorcycle with sound system intact, at your expense, within the warranty period to an authorised Harley-Davidson dealer.

Harley-Davidson's network of authorised dealers is large, and continues to expand. To find current contact information for your nearest authorised dealer, visit our website at www.h-d.com.au.

H-D U.S.A., LLC TRADEMARK INFORMATION

Bar & Shield, Boom!, Breakout, Cruise Drive, CVO, Digital Tech, Digital Technician, Digital Technician II, Electra Glide, Evolution, Fat Bob, Fat Boy, Forty-Eight, FXDR 114, Glaze, Gloss, H-D, H-Dnet.com, Harley, Harley-Davidson, HD, Heritage Softail, Iron 1200, Iron 883, Low Rider, Milwaukee-Eight, Night Rod, Profile, Reflex, Revolution X, Road Glide, Road King, Road Tech, Roadster, Screamin' Eagle, Seventy-Two, Slim, Softail, Sport Glide, Sportster, Street Bob, Street Glide, Street Rod, Sun Ray, Sunwash, SuperLow, Supersmart, SYN3, TechLink, TechLink II, Tour-Pak, Tri Glide, Twin-Cooled, Ultra Classic, and Harley-Davidson Genuine Motor Parts and Genuine Motor Accessories are among the trademarks of H-D U.S.A., LLC.

PRODUCT REGISTERED MARKS

Apple, Alcantara S.p.A., Allen, Amp Multilock, Bluetooth, Brembo, CarPlay, City Navigator, Delphi, Deutsch, Dunlop, Dynojet, Fluke, G.E. Versilube, Garmin, Gunk, Hydroseal, Hylomar, iPhone, iPod, Kevlar, Lexan, Loctite, Lubriplate, Keps, K&N, Magnaflux, Marson Thread-Setter Tool Kit, MAXI fuse, Molex, Michelin, MPZ, Multilock, nano, NGK, Novus, Packard, Pirelli, Permatex, Philips, PJ1, Pozidriv, Road Tech, Robinair, S100, Sems, Siri, SiriusXM, Snap-on, Teflon, Threadlocker, Torca, Torco, TORX, Tufoil, Tyco, Ultratorch,

Velcro, X-Acto and XM Satellite Radio are among the trademarks of their respective owners.

NOTES

© 2019 H-D, 05/23/2019

Index

A

A2DP/AVRCP Profile (AV/Music).....	119
AM.....	75
Accessory Mode.....	49
Amplifier.....	47
Antenna.....	47
Audio Functions.....	41

B

Bluetooth.....	48, 119
----------------	---------

C

CB.....	213
Care and Cleaning.....	117
Charging a Phone.....	119
Cleaning.....	117
Controls.....	41
Customer service.....	1

D

Disconnecting the Vehicle Battery.....	49
--	----

E

Emergency CB Operation.....	6
Emergency Phone Number.....	6
Enabling Rear Controls.....	41

F

FCC CB Rules.....	213
FM.....	75

G

GPX Files.....	161, 162
----------------	----------

H

HFP+PBAP+AV Profile.....	119
Hands-Free Calling Profile (HFP).....	119

Index

Headset.....42

M

Manual.....1
Media Compartment (USB Port).....44
Media Compartment: USB Port.....44
Menu.....60
Message Access Profile (MAP).....119
Microphone.....42

N

Navigation.....5, 137, 160, 161, 162
164

P

Passenger Controls.....41
Phone.....119, 120, 126
126, 129, 132, 133
Phonebook Access Profile (PBAP).....119
Pre-Ride Checklist.....5

R

Radio.....75, 117
Rear (Passenger) Controls.....41
Regulatory Compliance.....213
Replaceable Screen Protector.....117
Rider Planner.....162

S

Safety.....3, 5, 6
6
Satellite Radio.....93
Setup.....60
Software.....72
Speakers.....46, 117
Specifications.....24

T

Text Messaging.....129
Total Harmonic Distortion (THD).....47
Trails.....160

Index

Turning Motorcycle On/Off.....49

U

USB Drive.....44

Updates.....72

W

WB.....75

© 2019 H-D, 05/23/2019