



## INSTRUCTIONS

GEI-50275A  
SUPERSEDES GEI-50275

RC

# PHASE DIRECTIONAL OVERCURRENT RELAYS



### Types

JBC51E	JBC54E
JBC52E	JBC77E
JBC53E	JBC78E

POWER SYSTEMS MANAGEMENT DEPARTMENT

GENERAL  ELECTRIC

GEI-50275 Phase Directional Overcurrent Relay Type JBC

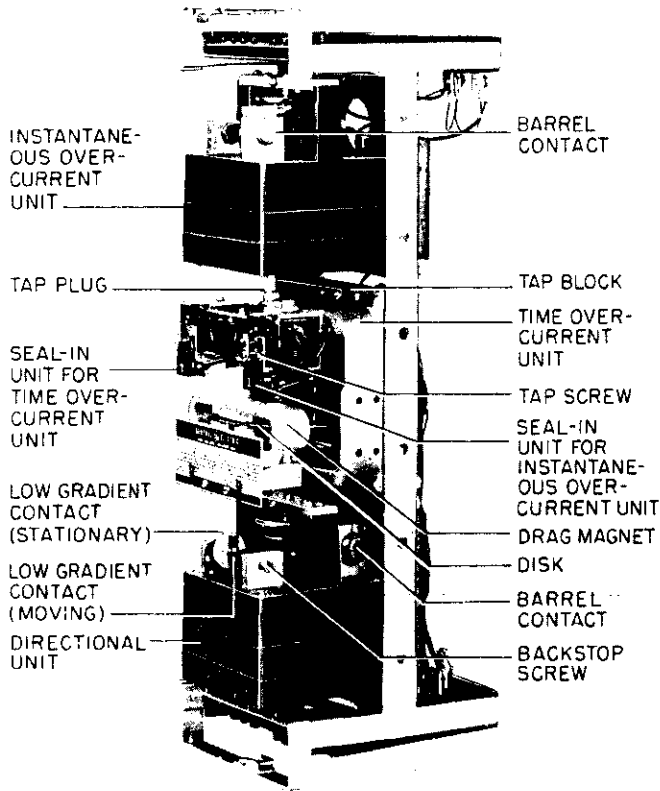

Front View

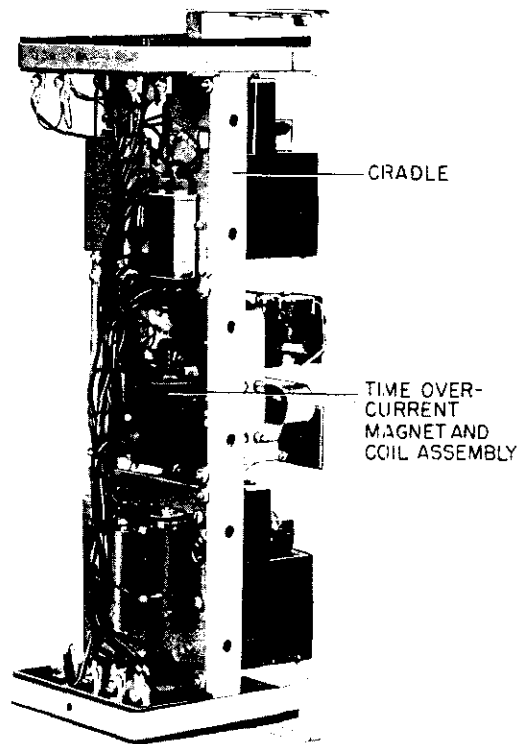

Rear View

Fig. 1 Type JBC51E Relay Unit Removed From Case

Fig. 1(8023335)Front View

Fig. 1(8023332)Rear View

ver (8023337)

# PHASE DIRECTIONAL OVERCURRENT RELAY

## TYPE JBC

### INTRODUCTION

Type JBC relays are single phase, directional overcurrent relays used primarily for the protection of feeders and transmission lines. They are available with inverse, very inverse or extremely inverse time characteristics.

They consist of three units, an instantaneous overcurrent unit (top) of the induction-cup type, a time overcurrent unit (middle) of the induction-disk type, and an instantaneous power-directional unit (bottom) of the induction-cup type. The directional unit is potential polarized and, by means of its closing contacts, directionally controls the operation of both the time overcurrent and instantaneous overcurrent units.

### APPLICATION

Type JBC relays are generally applied for phase fault protection of a single line. Since fault currents are usually highly lagging, the quadrature (90 degree) connection, shown in Fig. 9, provides the most reliable potential for the directional unit. At the relay terminals, the current, at unity power-factor load, leads the potential by 90 degrees. Since the relay has an approximate maximum torque angle characteristic of 45 degrees lead (current leads voltage), the directional unit will develop maximum operating torque when the fault current lags its unity power-factor position by about 45 degrees.

\* The differences between the various models covered by this instruction book are shown in Table I. Inverse time relays should be used on systems where the fault current flowing through a given relay is influenced largely by the system generating capacity at the time of the fault. Very inverse time and extremely inverse time relays should be used in cases where the fault current magnitude is dependent mainly upon the location of the fault in relation to the relay, and only slightly or not at all upon the system generating setup. The reason for this is that relays must be set to be selective with maximum fault current flowing. For fault currents below this value, the operating time becomes greater as the current is decreased. If there is a wide range in generating capacity, together with variation in short-circuit current with fault position, the operating time with minimum fault current may be exceedingly long with very inverse time relays and even longer with extremely inverse time relays. For such cases, the inverse time relay is more applicable.

\* The choice between very inverse and extremely inverse time relays is more limited than between them and the inverse time relay as they are more nearly alike in their time-current characteristic

curves. For grading with fuses the extremely inverse time relay should be chosen as the time-current curves more nearly match the fuse curve. Another advantage of the extremely inverse relay is that it is better suited than both the inverse and very inverse relays for picking up cold load. For any given cold load pick-up capability, the resulting settings will provide faster protection at high fault currents with the extremely inverse relay than with the less inverse relays.

\* TABLE I

Relay Model	Time Characteristics	Circuit Closing Contacts	Internal Connections
JBC51E	Inverse	One	Fig. 2
JBC52E	Inverse	Two	Fig. 3
JBC53E	Very Inverse	One	Fig. 4
JBC54E	Very Inverse	Two	Fig. 5
JBC77E	Extr. Inverse	One	Fig. 6
JBC78E	Extr. Inverse	Two	Fig. 7

### OPERATING CHARACTERISTICS

#### PICKUP

At the maximum torque angle, the directional unit will pick up at one percent of rated voltage with 2 amperes for relays with 1.5/6 ampere time overcurrent units, and 4 amperes for relays with 4/16 ampere time overcurrent units.

The maximum operating current required to close the time overcurrent unit contacts, at any time-dial position, will be within five percent of the tap plug setting.

The pickup of the instantaneous overcurrent unit can be adjusted over a four-to-one range as indicated in Table III.

#### RESET

The minimum percentage of minimum closing current at which the time overcurrent unit will reset is 90% for inverse-time relays and 85% for very inverse-time and extremely inverse-time relays. When the relay is de-energized, the time required for the disk to completely reset to the number 10 time dial position is approximately 6 seconds for inverse time relays and 60 seconds for very inverse-time and extremely inverse-time relays.

#### OPERATING TIME

The time curves for the directional unit are shown in Fig. 16 and Fig. 17.

*These instructions do not purport to cover all details or variations in equipment nor to provide for every possible contingency to be met in connection with installation, operation or maintenance. Should further information be desired or should particular problems arise which are not covered sufficiently for the purchaser's purposes, the matter should be referred to the General Electric Company.*

The time curves of the time overcurrent unit are shown in Figs. 18, 19 and 20 respectively for inverse-time, very inverse-time and extremely inverse-time relays. For the same operating conditions, the relay will operate repeatedly within one or two per cent of the same time.

The time curves for the instantaneous overcurrent unit are shown in Fig. 15.

**RATINGS**

**CURRENT CIRCUITS**

The continuous and short time ratings of the time overcurrent unit operating coil circuit are shown in Table II. These same ratings are applicable to the directional unit operating coil circuit except that its continuous rating is independent of changes in the time overcurrent unit tap setting. Hence, the information associated with the asterisk under Table II does not apply to the directional unit operating coil. Table III shows the ratings of the available ranges of the instantaneous overcurrent unit. Since all operating current circuits are normally connected in series, the operating coil ratings of all three units should be considered in determining the rating of the entire operating circuit.

**TABLE II**

**RATINGS OF TIME OVERCURRENT UNIT OPERATING COILS**

TAP RANGE (AMPS)	TAP RATINGS (AMPS)	* CONT. RATING (AMPS)	ONE SEC. RATING (AMPS)
1.5/6	1.5, 2, 2.5, 3, 4, 5, 6	5	200
4/16	4, 5, 6, 8, 10, 12, 16	10	220

\* Applies to all taps up to and including this value. The continuous rating of higher current taps is the same as tap value.

**TABLE III**

**RATINGS OF INSTANTANEOUS OVERCURRENT UNIT OPERATING COILS**

PICKUP RANGE (AMPS)	CONTINUOUS RATING (AMPS)	ONE SECOND RATING (AMPS)
2-8	5	150
4-16	5	150
10-40	5	220
20-80	5	220
40-160	5	220

**SEAL-IN UNIT**

The rating and impedance of the seal-in unit for the 0.2 and 2 ampere taps are given in Table IV. The tap setting used will depend on the current

drawn by the trip coil. The current ratings are either AC or DC.

The 0.2 ampere tap is for use with trip coils which operate on currents ranging from 0.2 up to 2.0 amperes, at the minimum control voltage. If this tap is used with trip coils requiring more than 2 amperes, there is a possibility that the resistance of 7 ohms will reduce the current to so low a value that the breaker will not be tripped.

The 2 ampere tap should be used with trip coils that take two amperes or more at minimum control voltage, provided the current does not exceed 30 amperes at the maximum control voltage. If the tripping current exceeds 30 amperes, the connections should be arranged so that the induction unit contacts will operate an auxiliary relay which in turn energizes the trip coil or coils. On such an application, it may be necessary to connect a loading resistor in parallel with the auxiliary relay coil to allow enough current to operate the target seal-in unit.

**TABLE IV**

**SEAL-IN UNIT RATINGS**

	2 AMP TAP	0.2 AMP TAP
Carry-Tripping Duty	30 Amps	3 Amps
Carry Continuously	3 Amps	0.3 Amps
DC Resistance	0.13 Ohms	7 Ohms
Impedance (60 cycles)	0.53 Ohms	52 Ohms

**CONTACTS**

The current-closing rating of the induction unit contacts is 30 amperes for voltages not exceeding 250 volts. Their current-carrying rating is limited by the tap rating of the seal-in unit.

**BURDENS**

The potential circuit burden of the directional unit at 60 cycles and rated volts is 10 volt-amperes at 0.89 power factor. Table V gives the current circuit burden of the directional unit. Table VI gives the total burden of the time overcurrent unit plus instantaneous overcurrent unit.

**TABLE V**

**DIRECTIONAL UNIT CURRENT CIRCUIT BURDENS AT 60 CYCLES AND 5 AMPERES**

TAP RANGE	IMPED. (OHMS)	VOLT-AMPERES	POWER FACTOR	WATTS
1.5/6	0.46	12.0	0.52	6.24
4/16	0.13	3.3	0.40	1.32

\* TABLE VI  
BURDENS OF OVERCURRENT UNITS (TIME AND INSTANTANEOUS)  
AT 60 CYCLES

Time Characteristic	RANGE		BURDENS AT MINIMUM PICKUP OF TIME UNIT					OHMS IMPEDANCE AT		* VA At 5 Amps
	Time Unit	Inst. Unit	Eff. Res. (Ohms)	React. (Ohms)	* Imped. (Ohms)	+ Volt-Amps	Power Factor	3 Times Min. P.U.	10 Times Min. P.U.	
Inverse	1.5/6	2-8	1.00	2.70	2.90	6.5	0.35	1.70	1.00	75
Inverse	1.5/6	4-16 10-40 20-40	0.96	2.60	2.80	6.3	0.34	1.70	0.97	70
Inverse	4/16	2-8	0.23	0.41	0.47	7.5	0.49	0.28	0.16	12
Inverse	4/16	4-16	0.18	0.38	0.42	6.7	0.42	0.25	0.15	10.5
Inverse	4/16	10-40 20-80	0.15	0.37	0.40	6.1	0.38	0.24	0.14	10.0
Very Inverse	1.5/6	2-8	0.32	0.60	0.68	1.5	0.47	0.64	0.55	17
Very Inverse	1.5/6	4-16 10-40 20-80	0.25	0.51	0.57	1.3	0.44	0.53	0.46	14
Very Inverse	4/16	2-8	0.14	0.13	0.19	3.0	0.73	0.18	0.15	4.7
Very Inverse	4/16	4-16	0.09	0.11	0.14	2.2	0.64	0.13	0.11	3.5
Very Inverse	4/16	10-40 20-80	0.06	0.10	0.12	1.9	0.50	0.11	0.10	3.0
Extremely Inverse	1.5/6	2-8	0.17	0.26	0.31	0.70	0.55	0.31	0.30	7.0
Extremely Inverse	1.5/6	4-16	0.14	0.18	0.24	0.54	0.58	0.24	0.23	6.0
Extremely Inverse	1.5/6	10-40 20-80 40-160	0.13	0.16	0.21	0.47	0.62	0.21	0.20	5.2
Extremely Inverse	4/16	4-16	0.045	0.065	0.079	1.26	0.57	0.079	0.078	1.98
Extremely Inverse	4/16	10-40	0.038	0.048	0.061	0.98	0.62	0.061	0.060	1.53
Extremely Inverse	4/16	20-80	0.036	0.042	0.053	0.88	0.65	0.055	0.054	1.38

\* The impedance values given are those for the minimum tap of each relay. The impedance for other taps, at pick-up current (tap rating), varies inversely approximately as the square of the current rating. Example: for the Type JBC51E relay, 1.5/6 amperes, the impedance of the 1.5 ampere tap is 2.90 ohms. The impedance of the 3 ampere tap, at 3 amperes, is approximately  $(1.5/3)^2 \times 2.90 = 0.725$  ohms.

+ Some companies list relay burdens only as the volt-ampere input to operation at minimum pickup. This column is included so a direct comparison can be made. It should not be used in calculating volt-ampere burdens in a CT secondary circuit, since the burden at 5 amperes is used for this purpose.

‡ Calculated from burden at minimum pickup.

## RECEIVING, HANDLING AND STORAGE

These relays, when not included as a part of a control panel will be shipped in cartons designed to protect them against damage. Immediately upon receipt of a relay, examine it for any damage sustained in transit. If injury or damage resulting from rough handling is evident, file a damage claim at once with the transportation company and promptly notify the nearest General Electric Apparatus Sales Office.

Reasonable care should be exercised in un-

packing the relay in order that none of the parts are injured or the adjustments disturbed.

If the relays are not to be installed immediately, they should be stored in their original cartons in a place that is free from moisture, dust and metallic chips. Foreign matter collected on the outside of the case may find its way inside when the cover is removed and cause trouble in the operation of the relay.

GEI-50275 Phase Directional Overcurrent Relay Type JBC

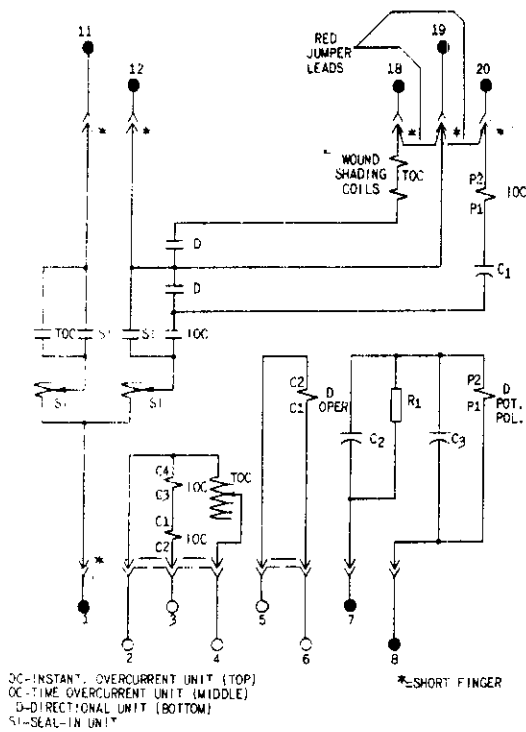

Fig. 2 Internal Connections For Type JBC51E Relay (Front View)

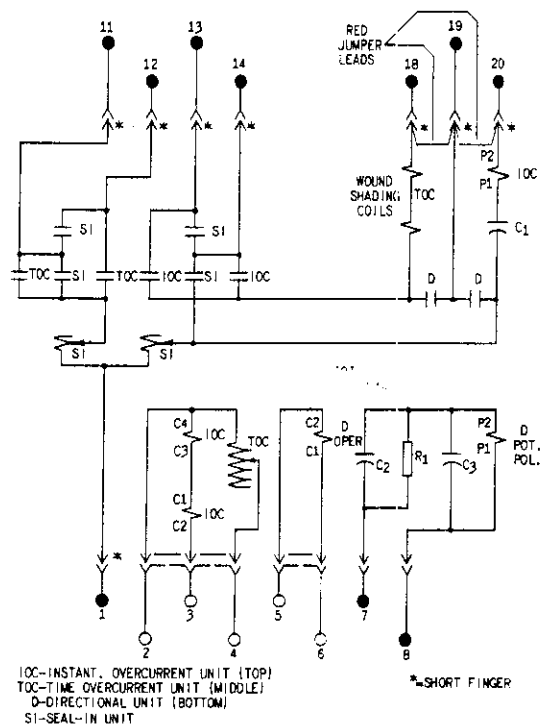

Fig. 3 Internal Connections For Type JBC52E Relay (Front View)

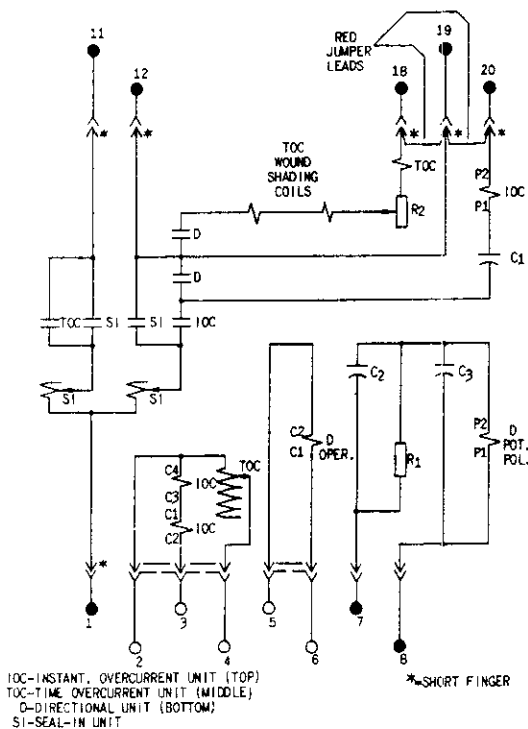

Fig. 4 Internal Connections For Type JBC53E Relay (Front View)

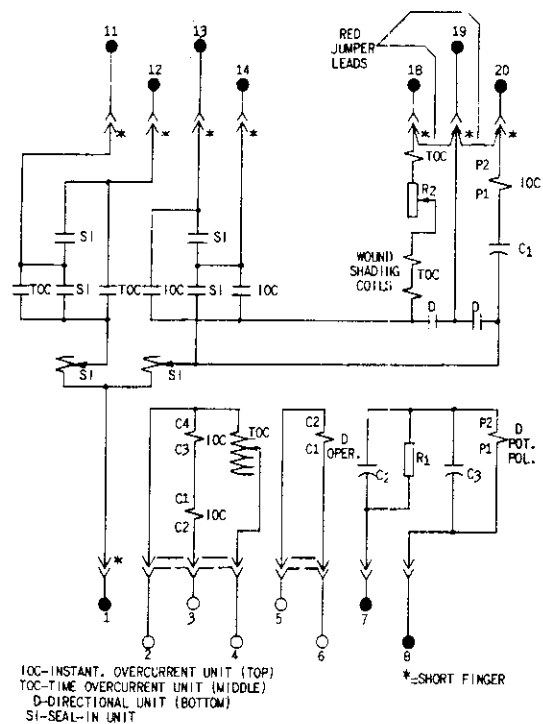

Fig. 5 Internal Connections For Type JBC54E Relay (Front View)

Fig. 6(0127A9427-0)

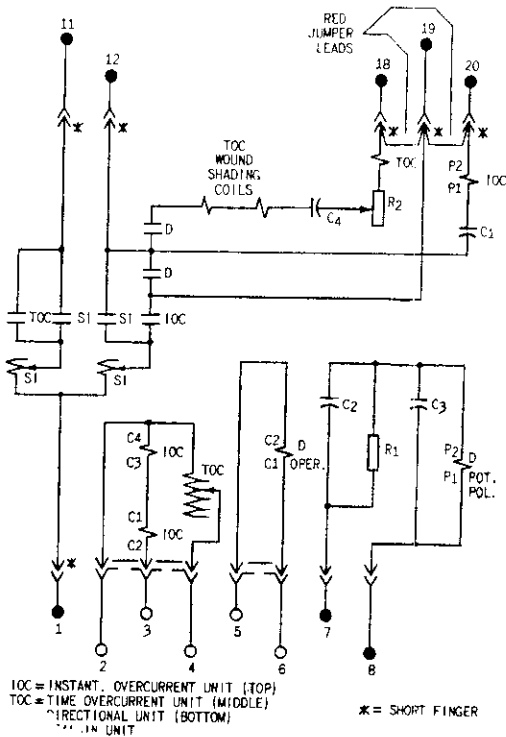
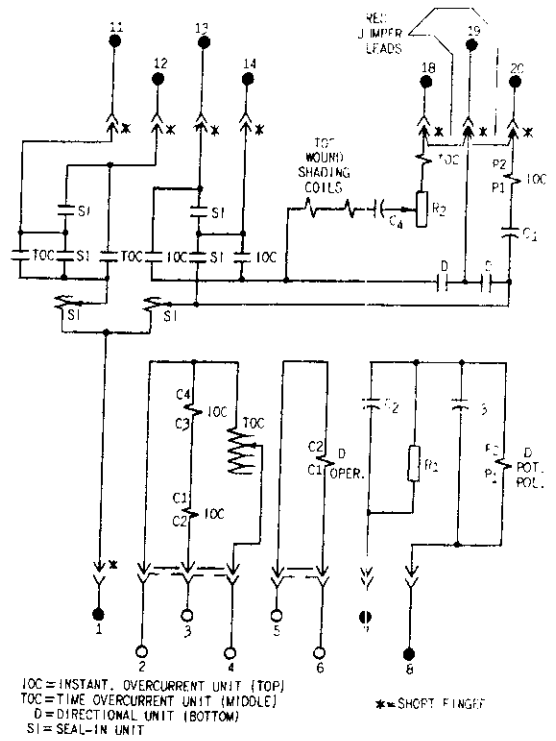

Fig. 7(0127A9428-0)



\* Fig. 6 Internal Connections for Type JBC77E Relay (Front View)

\* Fig. 7 Internal Connections for Type JBC78E Relay (Front View)

Fig. 8(K-6077069-2)

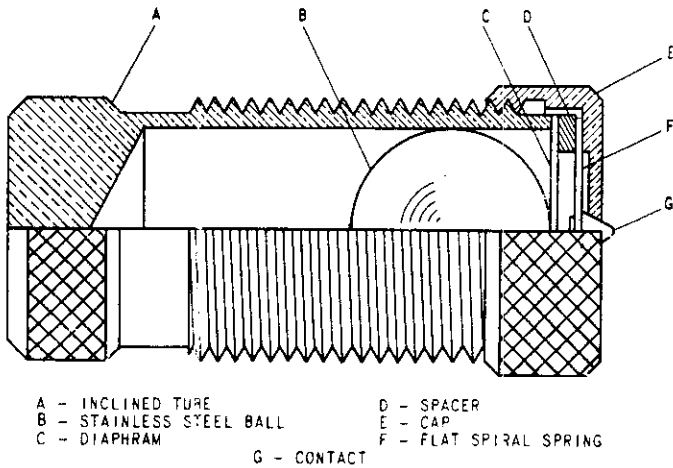

Fig. 9(418A932-0)

Fig. 8 Barrel Contact Assembly For The Directional And Instantaneous Overcurrent Units

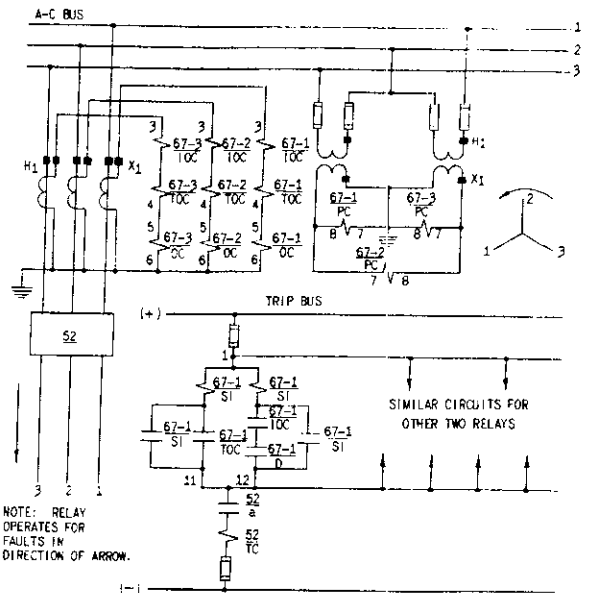
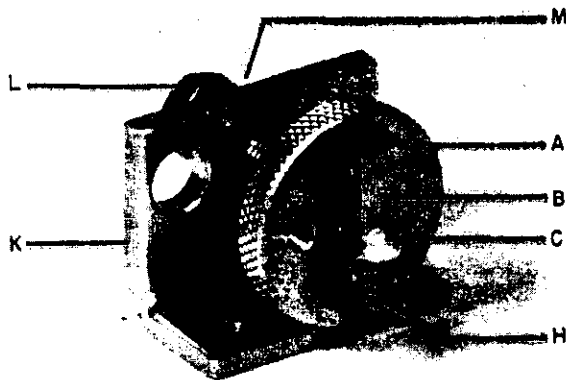
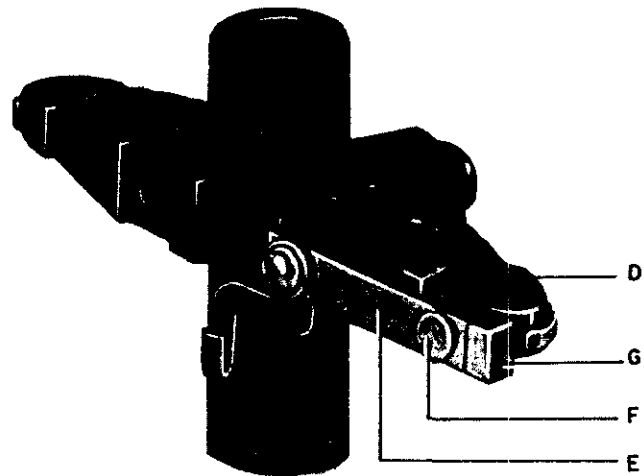

Fig. 9 External Connections For Three Single Phase Type JBC Relays For Directional Phase Fault Protection Of A Single Line



Stationary Contact Assembly



Moving Contact Assembly

- |                            |                     |                   |                            |
|----------------------------|---------------------|-------------------|----------------------------|
| A - Contact Dial           | K - Contact Support | D - Contact Arm   | F - Contact Tip            |
| B - Contact Brush          | L - Mounting Screw  | E - Contact Brush | G - Contact Brush Retainer |
| C - Contact Tip            | M - Lockout         |                   |                            |
| H - Contact Brush Retainer |                     |                   |                            |

Fig. 10 Low Gradient Contact Assembly For The Directional Unit

## DESCRIPTION

### TIME OVERCURRENT UNIT

The inverse time overcurrent unit consists of a tapped current operating coil wound on a U-magnet iron structure. The tapped operating coil is connected to taps on the tap block. The U-magnet contains wound shading coils which are connected in series with a directional unit contact. When power flow is in such a direction as to close the directional unit contacts, the shading coils act to produce a split-phase field which, in turn, develops torque on the operating disk.

The very inverse and extremely inverse time overcurrent units are of the wattmetric type similar to that used in watthour meters except as follows: the upper portion of the iron structure has two concentric windings on the middle leg of the magnetic circuit. One of these is a tapped current winding connected to taps on the tap block; the other is a floating winding which is connected in series with a directional unit contact, a resistor, and the two coils on the lower legs of the magnetic circuit. When power flow is in such a direction as to close the directional unit contacts, the unit develops torque on the operating disk.

The disk shaft carries the moving contact which completes the trip circuit when it touches the stationary contact or contacts. The shaft is restrained by a spiral spring to give the proper contact-closing current, and its motion is retarded by a permanent magnet acting on the disk to produce the desired time characteristic. The variable

retarding force resulting from the gradient of the spiral spring is compensated by the spiral shape of the induction disk, which results in an increased driving force as the spring winds up.

The torque control circuits of both the time overcurrent and instantaneous overcurrent units are wired to terminals on the relay contact block. These terminals are shorted together by internally connected red jumper leads when the relays leave the factory (see Figs. 2 to 7 inclusive). If external torque control is desired, these jumper leads, should be removed.

### DIRECTIONAL UNIT

The directional unit is of the induction-cylinder construction with a laminated stator having eight poles projecting inward and arranged symmetrically around a stationary central core. The cuplike aluminum induction rotor is free to operate in the annular air gap between the poles and the core. The poles are fitted alternately with current operating coils and potential polarizing coils.

The principle by which torque is developed is the same as that of an induction disk relay with a wattmetric element, although, in arrangement of parts, the unit is more like a split-phase induction motor. The induction-cylinder construction provides higher torque and lower rotor inertia than the induction-disk construction, resulting in a faster and more sensitive relay.

Fig. 10(8027689)Stationary

Fig. 10(8023399)Moving



## INSTANTANEOUS OVERCURRENT UNIT

The instantaneous overcurrent unit is similar in construction to the directional unit described above, differing only in coil turns and connections. The four corner coils consist of two windings, an inner winding consisting of a large number of turns of fine wire, and an outer winding having a few turns of heavy wire. The outer windings of the corner coils, together with the four side coils, are all connected in series with the operating coil of the time overcurrent unit. The inner windings of the corner coils are all connected in series, and in turn are connected in series with a capacitor and a contact of the directional unit. This circuit thus controls the torque of the instantaneous overcurrent unit. When the directional unit contacts are open, the instantaneous overcurrent unit will develop no torque. When the directional unit contacts are closed, the instantaneous overcurrent unit will develop torque in proportion to the square of the current.

The instantaneous overcurrent unit develops operating torque in a direction opposite to that of the directional unit. This makes the relay less susceptible to the effects of shock.

## SEAL-IN UNIT

The seal-in units for both the time-overcurrent and instantaneous-overcurrent contacts are mounted on the middle unit, as indicated in Fig. 1.

The left seal-in unit operates in conjunction with the time-overcurrent unit contacts and is labeled "T". Its coil is in series and its contacts in parallel with the main contacts of the time-overcurrent unit so that when the main contacts close, the seal-in unit will pick up and seal-in around the main contact.

The right seal-in unit, labeled "I" operates in conjunction with the instantaneous overcurrent unit. Its coil is in series with the instantaneous unit contact and a contact of the directional unit, and its contacts are connected to seal-in around these two contacts when the unit operates.

Both seal-in units are equipped with targets which are raised into view when the unit operates.

These targets latch and remain exposed until manually released by means of the button projecting below the lower-left corner of the cover.

## CONTACTS

### LOW GRADIENT CONTACT

The directional unit contacts (left front), which control the time overcurrent unit are shown in Fig. 10. They are of the low gradient type specially constructed to minimize the effects of vibration. Both the stationary and moving contact brushes are made of low gradient material which, when subjected to vibration, tend to follow one another, hence, they resist contact separation.

The contact dial (A) supports the stationary contact brush (B) on which is mounted a conical contact tip (C). The moving contact arm (D) supports the moving contact brush (E) on which is mounted a button contact tip (F). The end of the moving contact brush bears against the inner face of the moving contact brush retainer (G). Similarly, the end of the stationary contact brush bears against the inner face of the stationary contact brush retainer (H). The stationary contact support (K) and the contact dial are assembled together by means of a mounting screw (L) and two locknuts (M).

### BARREL CONTACT

The directional unit contacts (right rear), which control the instantaneous overcurrent unit, are shown in Fig. 8. They are specially constructed to suppress bouncing. The stationary contact (G) is mounted on a flat spiral spring (F) backed up by a thin diaphragm (C). These are both mounted in a slightly inclined tube (A). A stainless steel ball (B) is placed in the tube before the diaphragm is assembled. When the moving contact hits the stationary contact, the energy of the former is imparted to the latter and thence to the ball, which is free to roll up the inclined tube. Thus, the moving contact comes to rest with substantially no rebound or vibration. To change the stationary contact mounting spring, remove the contact barrel and sleeve as a complete unit after loosening the screw at the front of the contact block. Unscrew the cap (E). The contact and its flat spiral mounting spring may then be removed.

## INSTALLATION

### LOCATION

The location should be clean and dry, free from dust and excessive vibration and well lighted to facilitate inspection and testing.

### MOUNTING

The relay should be mounted on a vertical surface. The outline and panel drilling diagram is shown in Fig. 21.

### CONNECTIONS

The internal connection diagrams for the various relays are shown in Figs. 2 to 7. A typical wiring diagram is shown in Fig. 9. Since phase sequence is important for the correct operation of Type JBC relays, the rotation specified in Fig. 9 must be adhered to. Unless mounted on a steel panel which adequately grounds the relay case, it is recommended that the case be grounded through a mounting stud or screw with a conductor not less than #12 B&S gauge copper wire or its equivalent.

\* Terminal 12 of JBC51, JBC53, JBC77 relays should be connected to the negative side of the DC bus.

### INSPECTION

At the time of installation, the relay should be inspected for tarnished contacts, loose screws, or other imperfections. If any trouble is found, it should be corrected in the manner described under MAINTENANCE.

### \* CAUTION

Every circuit in the drawout case has an auxiliary brush. It is especially important on current circuits and other circuits with shorting bars that the auxiliary brush be bent high enough to engage the connecting plug or test plug before the main brushes do. This will prevent CT secondary circuits from being opened.

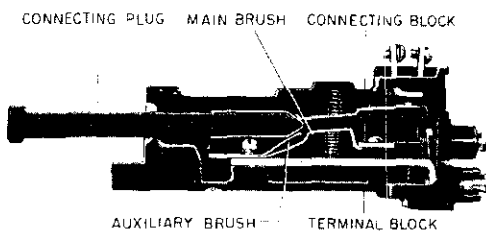

NOTE: AFTER ENGAGING AUXILIARY BRUSH, CONNECTING PLUG TRAVELS 1/4 INCH BEFORE ENGAGING THE MAIN BRUSH ON THE TERMINAL BLOCK

\* Fig. 11 Cross Section of Drawout Case Showing Position of Auxiliary Brush

### OPERATION

Before the relay is put into service, it should be given a check to determine that factory adjustments have not been disturbed. The time dial will be set at zero before the relay leaves the factory. It is necessary to change this setting in order to open the time overcurrent unit contacts.

## ADJUSTMENTS

### TIME OVERCURRENT UNIT

#### TARGET AND SEAL-IN UNIT (MARKED "T")

When used with trip coils operating on currents ranging from 0.2 to 2.0 amperes at the minimum control voltage, the target and seal-in tap screw should be set in the 0.2-ampere tap. When the trip-coil current ranges from 2 to 30 amperes at the minimum control voltage, the tap screw should be placed in the 2.0-ampere tap.

The seal-in tap screw is the screw holding the right-hand stationary contact of the seal-in unit. To change the tap setting, first remove the connecting plug. Then take a screw from the left-hand stationary contact and place it in the desired tap. Next, remove the screw from the other tap and place it back in the left-hand contact. This procedure is necessary to prevent the right-hand stationary contact from getting out of adjustment. Tap screws should never be left in both taps at the same time.

#### CURRENT SETTING

The minimum current at which time overcurrent unit will close its contacts is determined by the position of the plug in the tap block. The tap plate on this block is marked in amperes, as shown in Table II.

When the tap setting is changed with the relay in its case the following procedure must be followed: (1) remove the connecting plug; this de-energizes the relay and shorts the current transformer secondary winding. (2) remove the tap screw and place it in the tap marked for the desired pick-up current. (3) replace the connecting plug.

The minimum current required to rotate the disk slowly and to close the contacts should be within five per cent of the value marked on the tap plate for any tap setting and time dial position. If this adjustment has been disturbed, it can be restored by means of the spring adjusting ring. The ring can be turned by inserting a screw driver blade in the

notches around the edge. By turning the ring, the operating current of the unit can be brought into agreement with the tap setting employed. This adjustment also permits any desired setting to be obtained intermediate between the available tap settings.

Test connections for making pickup and time checks on the time overcurrent unit are shown in Fig. 12. Use a source of 120 volts or greater with

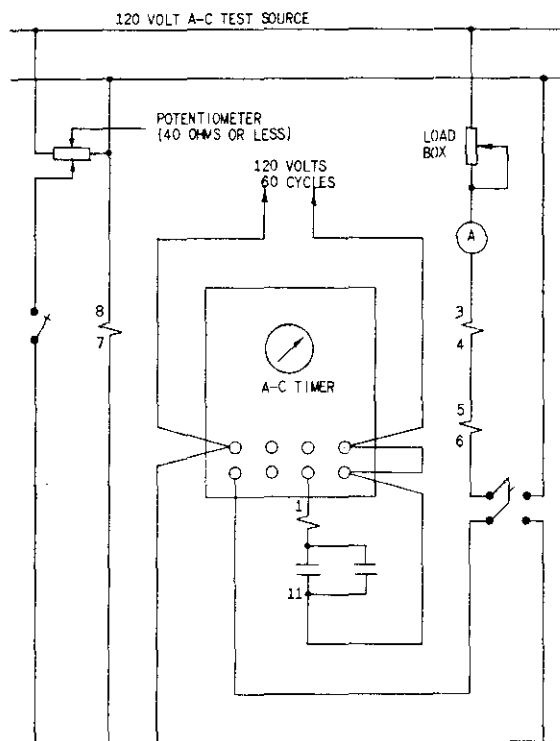

Fig. 12 Test Connections For Checking Pickup And Operating Time Of The Time Overcurrent Unit

Fig. 11 (8025039)

Fig. 12 (418A973-0)

good wave form and constant frequency. Stepdown transformers or phantom loads should not be employed in testing induction relays since their use may cause a distorted wave form.

**TIME SETTING**

The operating time of the time overcurrent unit for any given value of current and tap setting is determined by the time dial setting. This operating time is inversely proportional to the current magnitude as illustrated by the time curves in Figs. 18, 19 and 20. Note that the current values on these curves are given as multiples of the tap setting. That is, for a given time dial setting, the time will be the same for 80 amperes on the 8 ampere tap as for 50 amperes on the 5 ampere tap, since in both cases, the current is 10 times tap setting.

If selective action of two or more relays is required, determine the maximum possible short-circuit current of the line and then choose a time value for each relay that differs sufficiently to insure the proper sequence in the operation of the several circuit breakers. Allowance must be made for the time involved in opening each breaker after the relay contacts close. For this reason, unless the circuit time of operation is known with accuracy, there should be a difference of about 0.5 second (at the maximum current) between relays whose operation is to be selective.

Fig. 13 (377A195-3)

Fig. 14 (418A970-0)

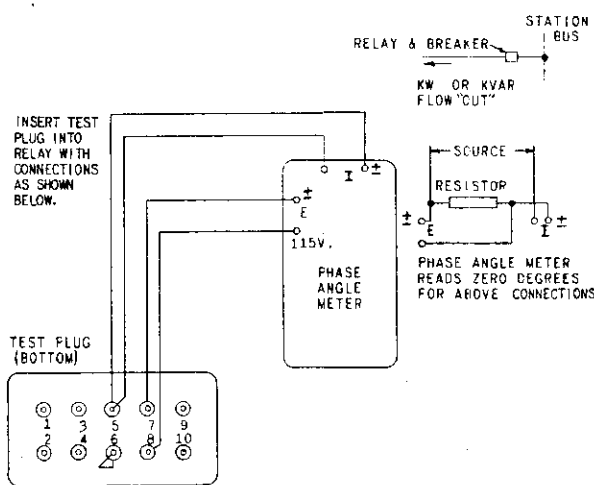

POWER FACTOR ANGLE (DEG. LEAD)	0-45	45-90	90-135	135-180	180-225	225-270	270-315	315-560
KW & KVAR DIRECTION WITH RESPECT TO THE BUS	KW OUT KVAR IN	KVAR IN KW OUT	KVAR IN KW IN	KW IN KVAR IN	KVAR OUT KW IN	KVAR OUT KW IN	KVAR OUT KW IN	KVAR OUT KW OUT
METER READING WITH PROPER EXT. CONNS.	90-135	135-180	180-225	225-270	270-315	315-360	0-45	45-90

THE ABOVE RANGES OF PHASE ANGLE METER READINGS ARE THE ANGLES BY WHICH THE CURRENT LEADS THE VOLTAGE WITH THE DESCRIBED CONDITIONS OF POWER (KW) AND REACTIVE POWER (KVAR) FLOW WITH THE STATION BUS CONSIDERED AS THE REFERENCE IN ALL CASES. > MEANS GREATER THAN. CAUTION: MAKE CORRECTIONS FOR METER ERRORS ON LOW CURRENTS, INHERENT IN SOME PHASE-ANGLE METERS.

Fig. 13 Test Connections For Checking Polarity Of The External Wiring To The Directional Unit

**EXAMPLE OF SETTING**

The time and current settings of the time overcurrent unit can be made easily and quickly. Each time value shown in Figs. 18, 19 and 20 indicates the time required for the contacts to close with a particular time-dial setting when the current is a prescribed number of times the current-tap setting. In order to obtain any particular time-current setting, insert the removable plug in the proper tap receptacle and adjust the time dial to the proper position. The following example illustrates the procedure in making a relay setting.

Assume that the relay is being used in a circuit where the circuit breaker should trip on a sustained current of approximately 450 amperes, and that the breaker should trip in one second on a short-circuit current of 3750 amperes. Assume further that current transformers of 60/1 ratio are used.

The current-tap setting is found by dividing minimum primary tripping current by the current transformer ratio. In this case, 450 divided by 60 equals 7.5 amperes. Since there is no 7.5 ampere tap, the 8-ampere tap is used. To find the proper time-dial setting to give one second time delay at 3750 amperes, divide 3750 by the transformer ratio. This gives 62.5 amperes secondary current which is 7.8 times the 8-ampere setting. By referring to the time-current curves Figs. 18, 19 and 20, it will be seen that 7.8 times the minimum operating current gives a one second time delay for a No. 3.4 dial setting on an inverse time relay, a \* No. 5.8 time dial setting on a very inverse time relay and a No. 10 time dial setting on an extremely inverse time relay.

The above results should be checked by means of an accurate timing device. Slight readjustment of the dial can be made until the desired time is obtained.

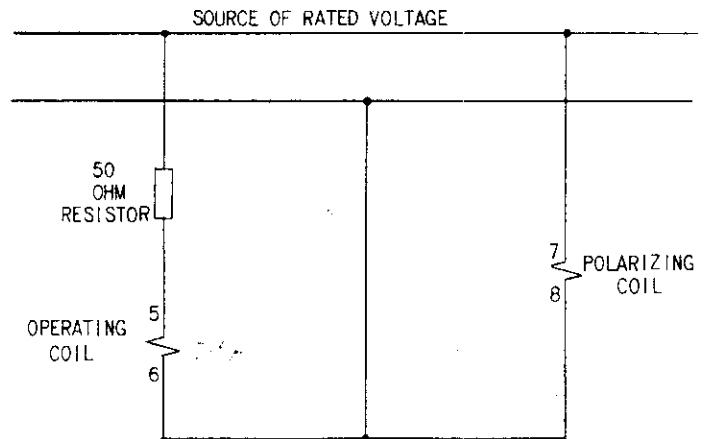

NOTE: THE DIRECTIONAL UNIT CONTACTS SHOULD CLOSE WHEN THE RELAY IS ENERGIZED WITH THE ABOVE CONNECTIONS.

Fig. 14 Test Connections For Checking Polarity Of The Directional Unit Internal Wiring

\* Denotes change since superseded issue.

Aid in making the proper selection of relay settings may be obtained on application to the nearest Sales Office of the General Electric Company.

## DIRECTIONAL UNIT

### POLARITY CHECK

The polarity of the external connections to the directional-unit may be verified by observing the direction of contact armature torque when the line is carrying load at unity power factor, or slightly lagging power factor. Note that in most directional overcurrent relay applications, the desired directions are: contact-closing for power flow away from the bus, and contact opening for power flow toward the bus. In case of doubt refer to Fig. 13 for a more accurate method of checking the polarity of the connections.

Fig. 14 shows the test connections for checking the polarity of the directional unit itself.

## INSTANTANEOUS OVERCURRENT UNIT

### TARGET AND SEAL-IN UNIT (MARKED "I")

The target and seal-in unit for the instantaneous

overcurrent unit, is mounted on the right-hand side of the time overcurrent unit and is identified by a white "I" engraved on its front. The unit is identical with the target and seal-in unit of the time overcurrent unit, and the same instructions should be followed in adjusting the unit.

### PICKUP SETTING

The pickup of the instantaneous overcurrent unit can be adjusted over a four-to-one range, as indicated in Table III, by varying the tension of the spiral control spring. The outside end of this spring is fastened to a post on the adjusting ring above the moving contact, and the ring is in turn clamped in position by a hexagonal-head locking screw. If this screw is loosened, the ring can be slipped to vary the spring tension.

In adjusting pickup, the desired pick-up current should be passed through the coils and the control spring should be adjusted until the contact just closes. The adjusting ring should then be locked in position and the pick-up current rechecked. Note that the directional-unit contacts must be held closed during this adjustment.

## MAINTENANCE

These relays are adjusted at the factory and it is advisable not to disturb the adjustments. If, for any reason, they have been disturbed, the following points should be observed in restoring them:

## TIME OVERCURRENT UNIT

### DISK AND BEARINGS

The jewel should be turned up until the disk is centered in the air gaps, after which it should be locked in this position by the set screw provided for this purpose. The upper bearing pin should next be adjusted so that the disk shaft has about 1/64 inch end play.

### CONTACT ADJUSTMENT

The contacts should have about 1/32 inch wipe. That is, the stationary contact tip should be deflected about 1/32 inch when the disk completes its travel. Wipe is adjusted by turning the wipe adjustment screw thereby adjusting the position of the brush relative to the brush stop. On two-circuit closing relays, the two stationary contact tips should be in the same vertical plane.

When the time dial is moved to the position where it holds the contacts just closed, it should indicate zero on the time-dial scale. If it does not and the brushes are correctly adjusted, shift the dial by changing the position of the arm attached to the shaft just below the time dial. Loosen the screw clamping the arm to the shaft and turn the arm relative to the shaft until the contacts just make for zero time-dial setting.

## DIRECTIONAL UNIT

### BEARINGS

The lower jewel bearing should be screwed all the way in until its head engages the end of the threaded core support. The upper bearing should be adjusted to allow about 1/64 inch end play in the shaft.

To check the clearance between the iron core and the inside of the rotor cup, press down on the contact arm near the shaft thus depressing the spring-mounted jewel until the cup strikes the iron. The shaft should move about 1/16 inch.

### CUP AND STATOR

Should it be necessary to remove the cup-type rotor from the directional unit, the following procedure should be followed:

All leads to the unit should first be disconnected and tagged for identification in reconnecting. The unit can then be removed from the cradle with its mounting plate still attached.

The upper of the three flat-head screws holding the unit to the plate should now be removed. On some models, it may be necessary to remove a resistor or capacitor to expose this screw. The four corner screws clamping the unit together, should next be removed, and the entire top structure lifted off. This gives access to the cup assembly and exposes the stator assembly, which should be protected to keep it free from dust and metallic particles until the unit is reassembled.

To remove the shaft and rotor from the contact head assembly, the spring clip at the top of the shaft must be pulled out and the clutch adjusting screw taken out of the side of the molded contact arm. The shaft and cup can now be pulled out of the molding. The rotor must be handled very carefully while it is out of the unit.

#### CONTACT ADJUSTMENTS

To facilitate adjustment of contacts, remove the two red jumper leads from terminals 18, 19, and 20 and use a neon indicating lamp in series with an AC voltage supply across terminals 18 & 19 and 19 & 20 to signify all contact closures. Refer to Fig. 10 and Fig. 8 for identification of low gradient and barrel contact parts respectively and proceed as follows:

Loosen slightly the locknut which secures the backstop screw (located at the right front corner of the unit) to its support. Unwind the backstop screw so that the moving contact arm is permitted to swing freely. Adjust the tension of each low gradient contact brush so that 1-2 grams of pressure are required at the contact tip in order to cause the end of the brush to separate from the inner face of its respective brush retainer. Adjust the spiral spring until the moving contact arm is in a neutral position, i.e., with the arm pointing directly forward. Loosen the locknut which secures the low gradient stationary contact mounting screw to the stationary contact support. Wind the mounting screw inward until the low gradient stationary and moving contact members just begin to touch. Unwind the mounting screw until the stationary contact brush is vertical with the stationary contact brush retainer down. Then tighten the locknut which secures the mounting screw to the stationary contact support.

Loosen slightly the screw which secures the barrel contact to its support. This screw should be only loose enough to allow the barrel to rotate in its sleeve, but not so loose as to allow the sleeve to move within the support. Wind the backstop screw in until the low gradient moving and stationary contact members just begin to touch. Wind the barrel contact in until the barrel contacts just begin to touch. Unwind the barrel contact 1/4 turn. Tighten the screw which secures the barrel contact to its support. Unwind the backstop screw 2/3 turn. Tighten the locknut screw which secures the backstop screw to its support. Finally, adjust the tension on the low gradient stationary contact brush such that, when the low gradient contacts are made and fully wiped in, there is approximately an equal deflection on each brush.

**CAUTION:** When the above adjustments are complete, be sure to replace the two red jumper leads.

#### TORQUE ADJUSTMENT

The directional unit is provided with a notched core which is used to minimize the torque produced on the rotor by current alone in the operating coils with the polarizing circuits de-energized. This adjustment is made at the factory and may be checked as follows:

First, short out the potential polarizing circuit. Adjust the control spring so that the moving contact structure is balanced between the stationary contact and the stop. This can be done by loosening the hexagonal-head locking screw, which clamps the spring adjusting ring in position, and turning the ring to the left until the balance point is reached.

Energize the operating circuit with 30 amperes for relays with 1.5/6 ampere time overcurrent units or 60 amperes for relays with 4/16 ampere time overcurrent units, and check that the contact arm does not move. The core should be turned in small steps until a point is reached where there is no "bias" torque from current alone. The core can be turned by loosening the large hexagonal nut on the bottom of the unit and turning the core by means of the slotted bearing screw. This screw should be held securely in position when the nut is retightened.

Keep in mind that currents of these magnitudes will cause the coils to overheat if left on too long. Therefore, leave the test current on only for short intervals and allow sufficient time between tests for the coils to cool.

After the torque adjustment has been made, the spiral spring should be set to have barely enough tension to swing the moving contact arm against the stop screw when the unit is de-energized. Sufficient tension will be obtained if the adjusting ring is rotated about 1/2 inch from the neutral position in the counterclockwise direction, as measured on the periphery of the ring.

#### CLUTCH ADJUSTMENT

The connections shown in Fig. 14 for the polarity check can also be used in making the clutch adjustment. The 50 ohm fixed resistor should be replaced with an adjustable resistor capable of providing the current range listed in Table VII for the relay type and rating in question. A screw, projecting from the side of the moving contact arm, controls the clutch pressure, and consequently, the current value which will cause the clutch to slip. With rated frequency and at rated volts, the clutch should be set to slip at the current values listed in Table VII. In all cases the current is in phase with the voltage.

TABLE VII  
DIRECTIONAL UNIT CLUTCH ADJUSTMENT

TAP RANGE (AMPERES)	AMPERES FOR CLUTCH TO SLIP
1.5/6	11
4/16	22

### INSTANTANEOUS OVERCURRENT UNIT

#### BEARINGS

The section BEARINGS, under DIRECTIONAL UNIT, also applies to the bearings of the instantaneous overcurrent unit.

**CUP AND STATOR**

The section CUP AND STATOR under DIRECTIONAL UNIT, also applies to the cup and stator of the instantaneous overcurrent unit.

**CONTACT ADJUSTMENTS**

The contact gap may be adjusted by loosening slightly the screw at the front of the contact support. The screw should be only loose enough to allow the contact barrel to rotate in its sleeve.

The backstop screw fastened with a locknut should hold the moving contact arm in a neutral position, i.e., with the arm pointing directly forward. Then, by rotating the barrel, advance the stationary contact until it just touches the moving contact. Next, back it away 2/3 turn to obtain approximately 0.020 inch gap. Last, tighten the screw which secures the barrel.

The moving contact may be removed by loosening the screw which secures it to the contact arm and sliding it from under the screw head.

TABLE VIII

INSTANTANEOUS OVERCURRENT UNIT  
CLUTCH ADJUSTMENT

PICKUP RANGE	CLUTCH MUST NOT SLIP AT	CLUTCH MUST SLIP AT
2 - 8	12	16
4 - 16	24	32
*10 - 40	-	-
*20 - 80	-	-
*40 - 160	-	-

\* Tighten clutch as much as possible.

**CLUTCH ADJUSTMENT**

The clutch on the instantaneous overcurrent unit can be adjusted by means of the screw located on the right-hand side of the moving contact arm. If the locknut is loosened and the screw turned in, the current at which the clutch will slip will be increased. The clutch should be adjusted to slip at the current values shown in Table VIII with the directional unit contacts held closed.

**CONTACT CLEANING**

For cleaning fine silver contacts, a flexible burnishing tool should be used. This consists of a flexible strip of metal with an etched roughened surface, resembling in effect a superfine file. The polishing action is so delicate that no scratches are left, yet corroded material will be removed rapidly and thoroughly. The flexibility of the tool insures the cleaning of the actual points of contact.

Fine silver contacts should not be cleaned with knives, files or abrasive paper or cloth. Knives or files may leave scratches which increase arcing and deterioration of the contacts. Abrasive paper or cloth may leave minute particles of insulating abrasive material in the contacts thus preventing contact closing.

The burnishing tool described above can be obtained from the factory.

**RENEWAL PARTS**

It is recommended that sufficient quantities of renewal parts be carried in stock to enable the prompt replacement of any that are worn, broken, or damaged.

When ordering renewal parts, address the

nearest Sales Office of the General Electric Company, specify quantity required, name of part wanted, and give complete nameplate data. If possible, give the General Electric Company requisition number on which the relay was furnished. Refer to Renewal Parts Publication GEF-4086.

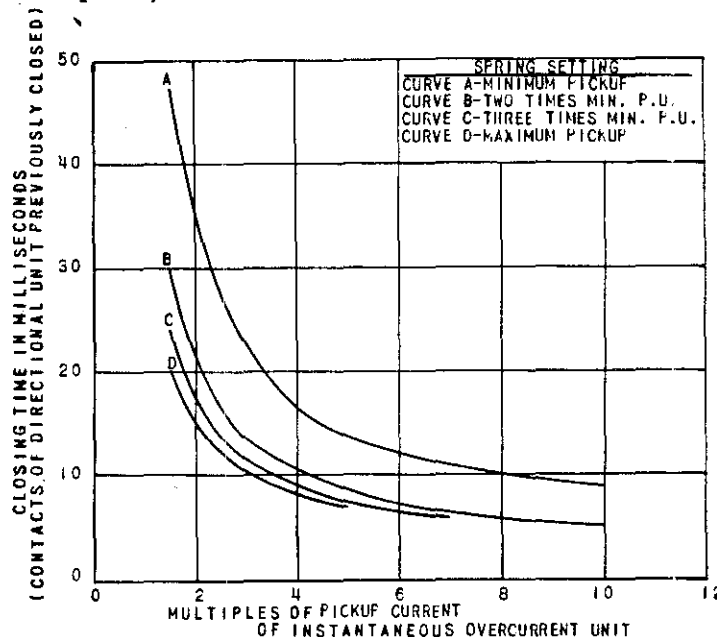

Fig. 15 Instantaneous Overcurrent Unit Time Curve

Fig. 15 (K-6556439-2)

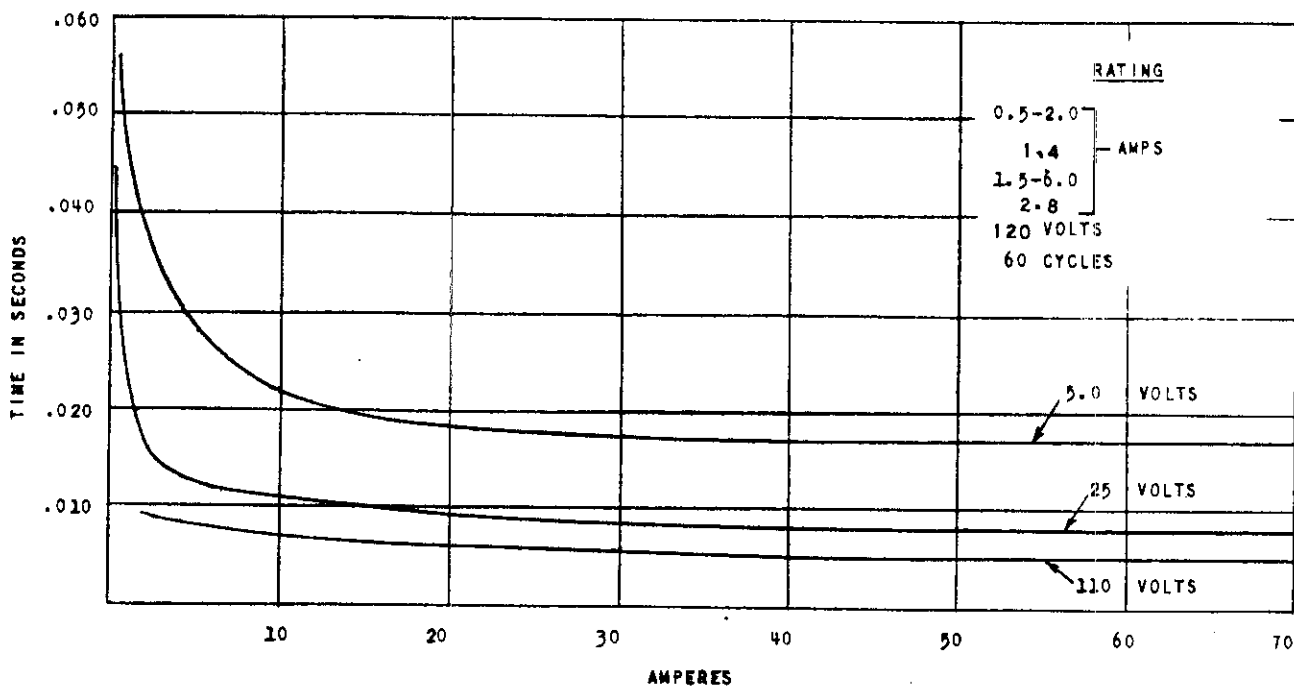

Fig. 17 (K-6154284-2)

Fig. 16 Directional Unit Time Curve (1.5/6 Ampere Range) for Voltage Applied in Phase with Current

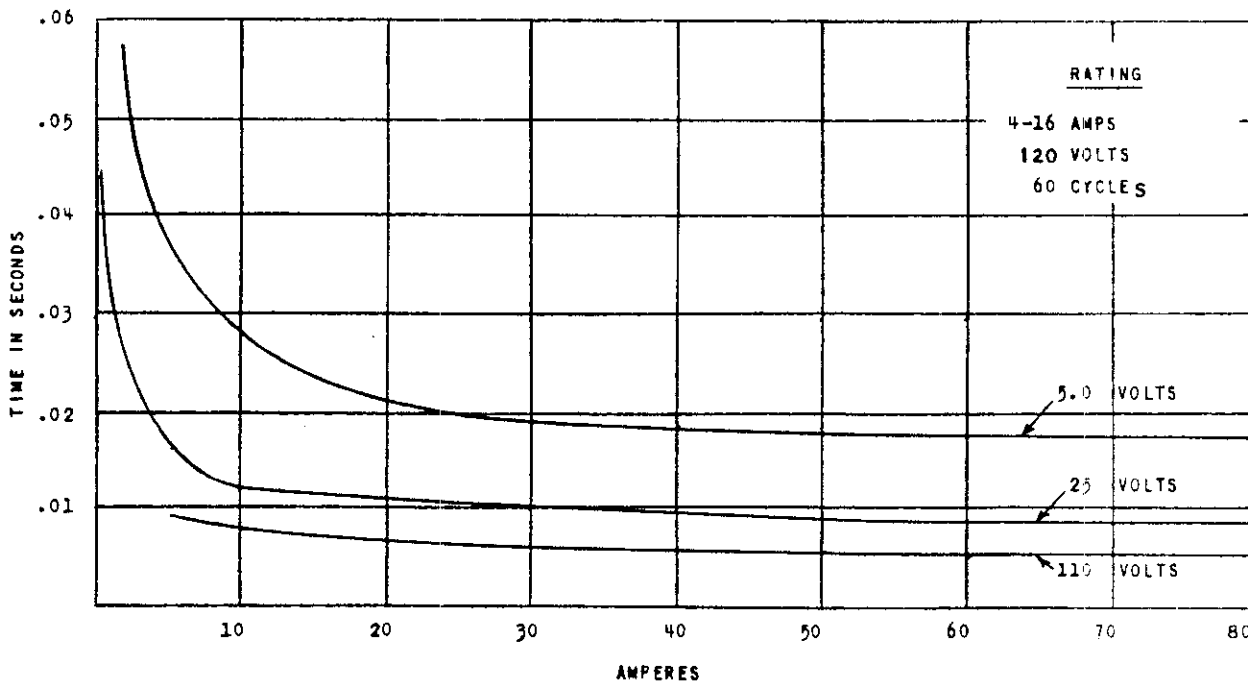

Fig. 16 (6154283-2)

Fig. 17 Directional Unit Time Curve (4/16 Ampere Range) for Voltage Applied In Phase with Current

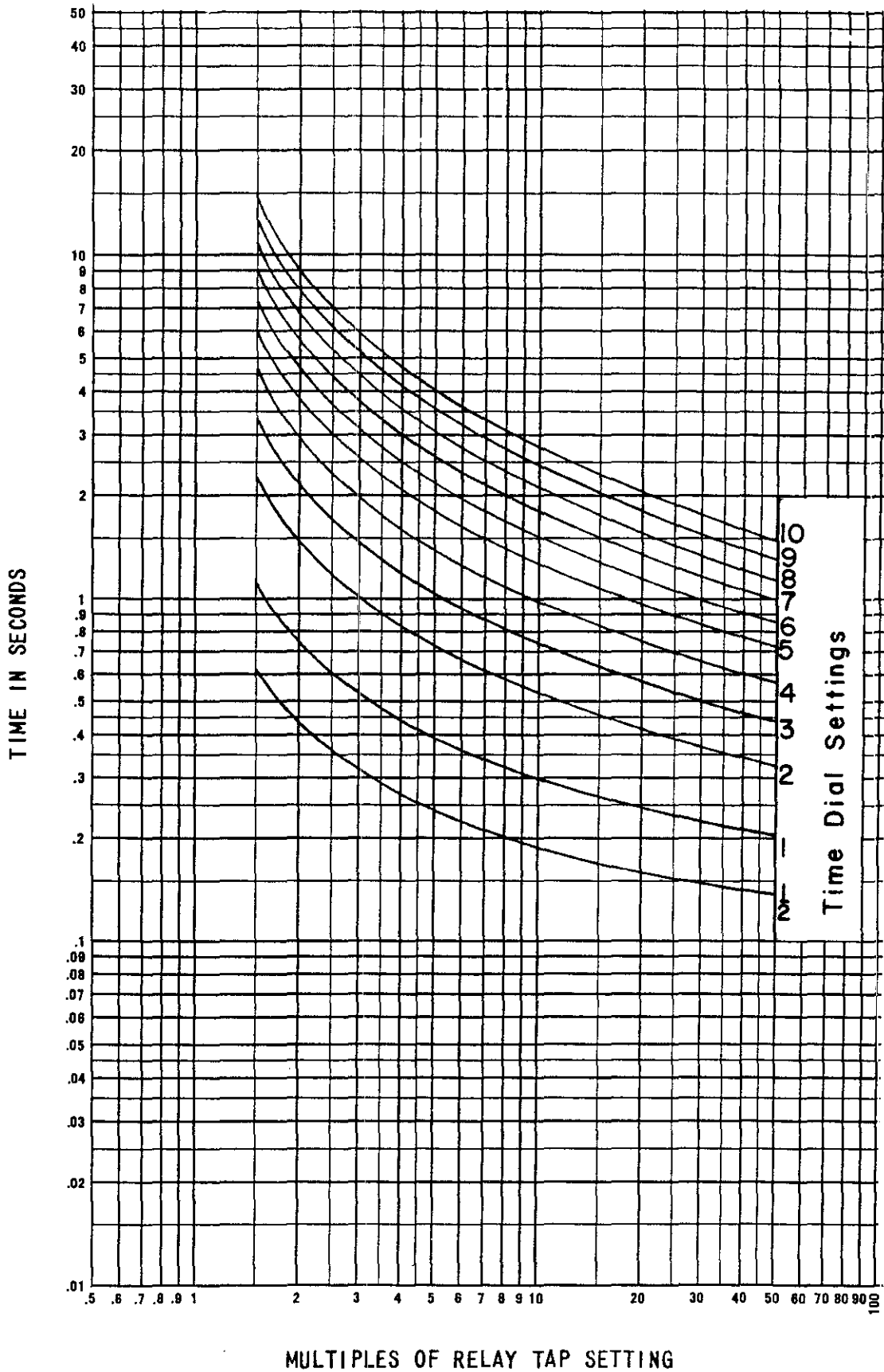

Fig. 18(08880269-0)

\* Fig. 18 Typical Time Curves for Inverse Time Overcurrent Unit (JBC51 and JBC52)

\* Denotes change since superseded issue.



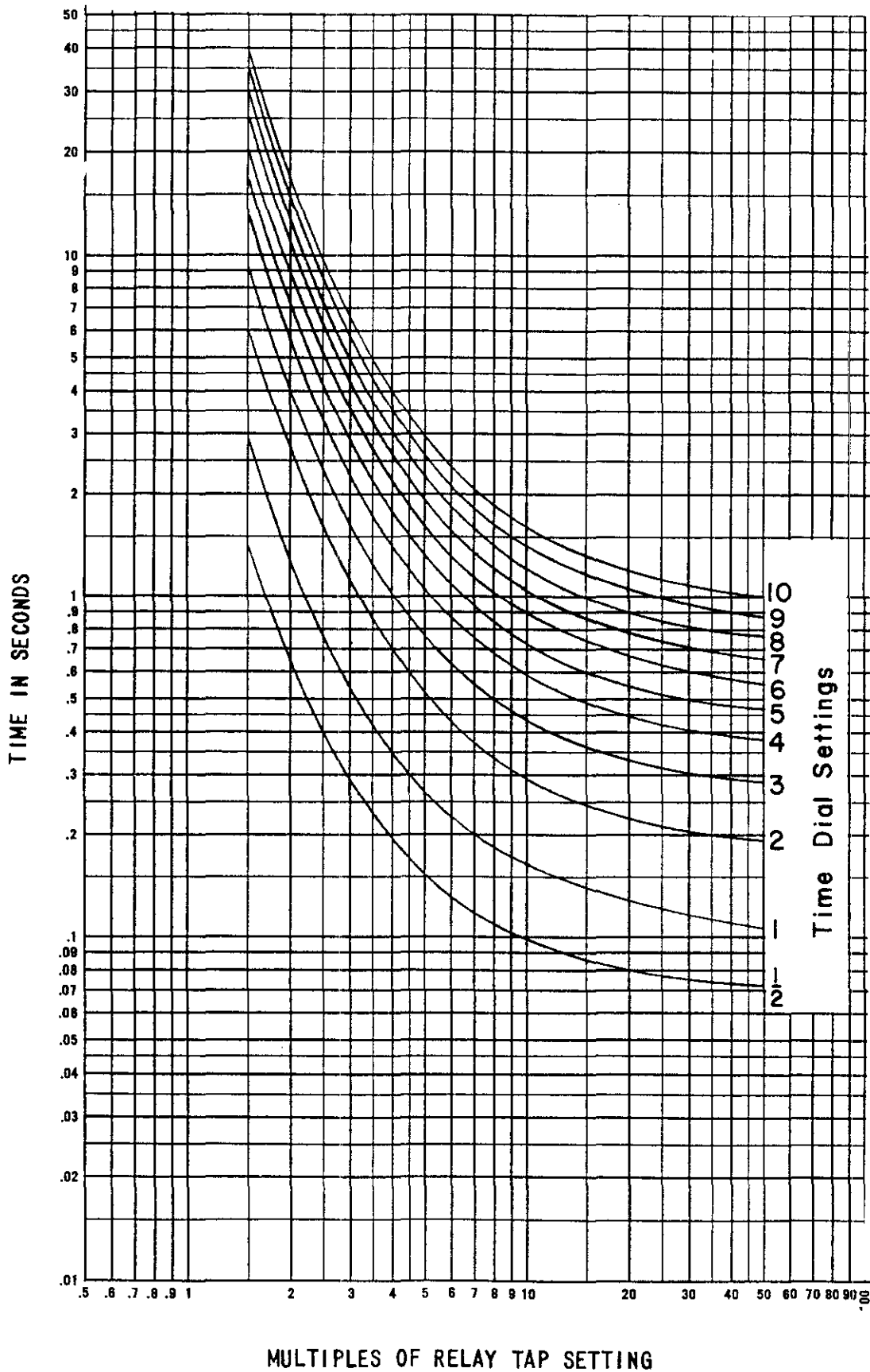
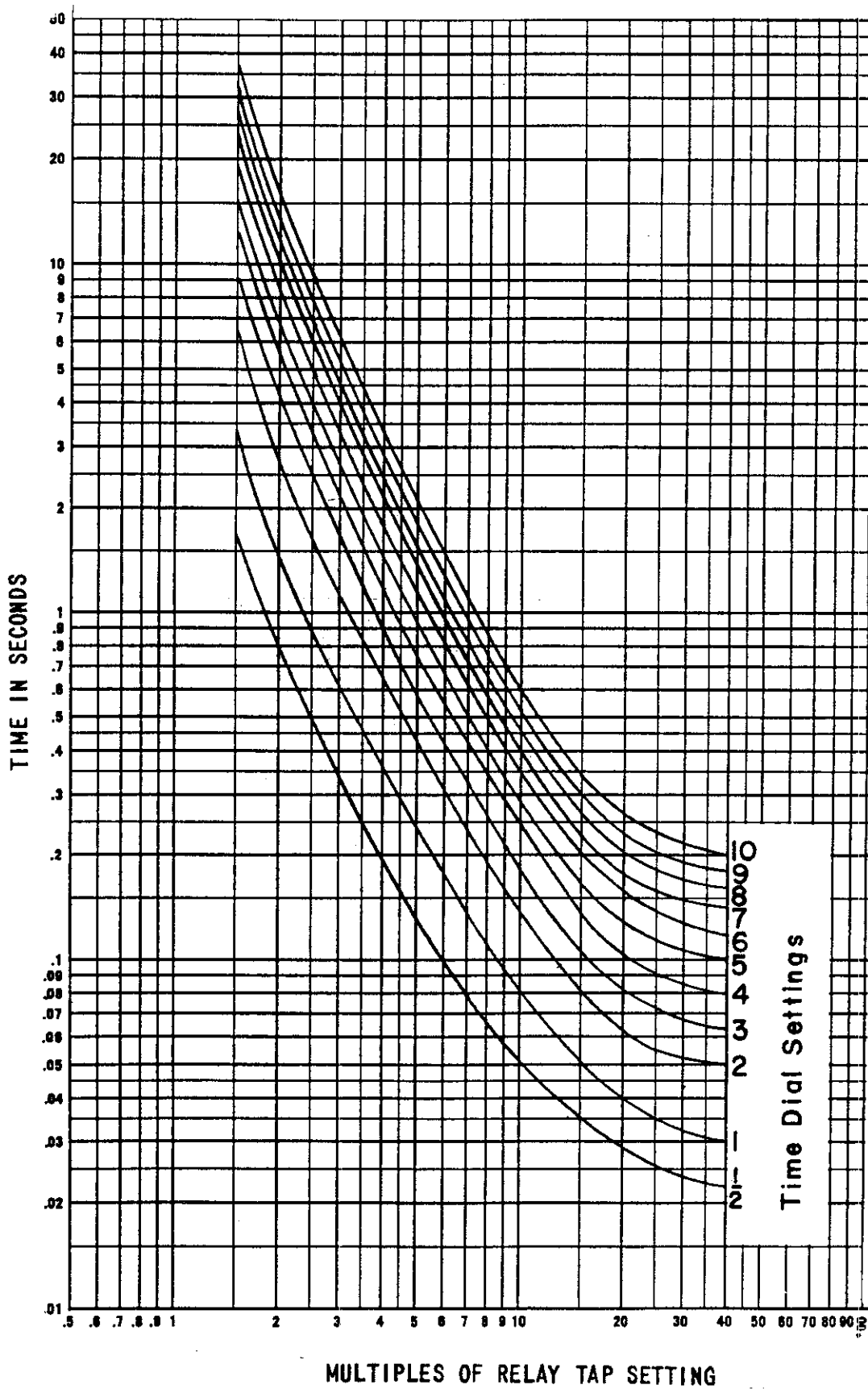

Fig. 19 (0888B0270-0)

\* Fig. 19 Typical Time Curves for Very Inverse Time Overcurrent Unit (JBC53 and JBC54)

\* Denotes change since superseded issue.



\* Fig. 20 Typical Time Curves for Extremely Inverse Time Overcurrent Unit (JBC77 and JBC78)

Fig. 21 (K-6209276-1)

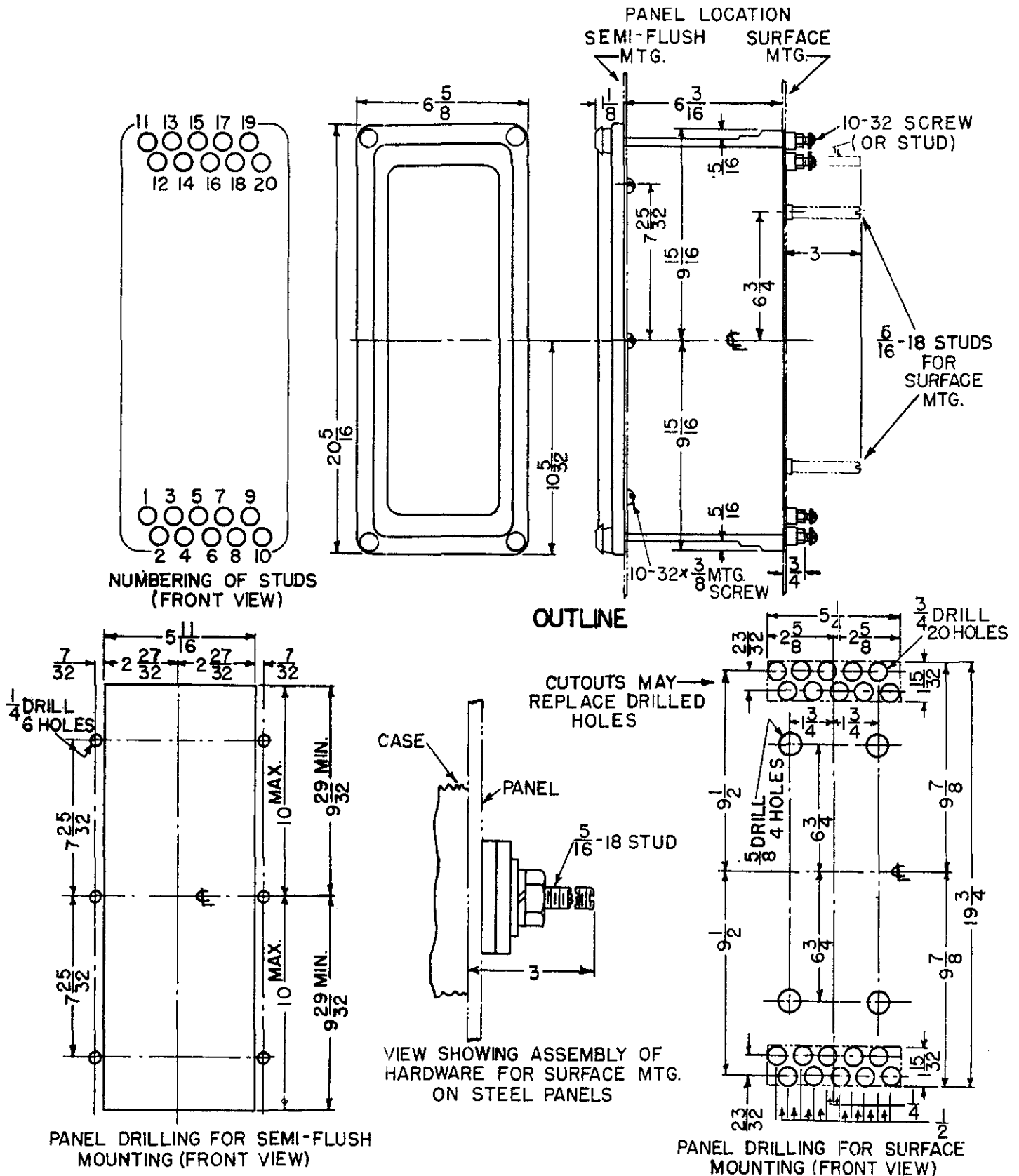

Fig. 21 Outline and Panel Drilling Dimensions for JBC Relays

## GENERAL ELECTRIC INSTALLATION AND SERVICE ENGINEERING OFFICES

### FIELD SERVICE OFFICE CODE KEY

- \* Mechanical & Nuclear Service
- † Electrical & Electronic Service
- ‡ Marine Service
- X Transportation

FOR YOUR LASTING SATISFACTION ... with the performance and availability of your General Electric equipment, GE provides this nationwide network of field service offices, serving utility, industrial, transportation and marine users. Qualified field engineers provide installation, start-up, employee training, engineering maintenance and other services, throughout the productive life of the equipment. For full information, call your nearest Installation & Service Engineering office.

<b>ALABAMA</b>	<b>LOUISIANA</b>	<b>OKLAHOMA</b>
* † Birmingham 35205 . . . . . 2151 Highland Ave.	* † Baton Rouge 70806 . . . . . 8312 Florida Blvd.	* † Oklahoma City 73106 . . . . . 2030 Classen Blvd.
* † Mobile 36609 . . . . . 1111 S. Beltline Highway	* † New Orleans 70125 . . . . . 4747 Earhart Blvd.	* † Tulsa 74105 . . . . . P. O. Box 766, Southside Sta.
<b>ALASKA</b>	* † Shreveport 71104 . . . . . 2620 Centenary Blvd.	
† Anchorage 99501 . . . . . 115 Whitney Rd.	† Monroe 71201 . . . . . 1028 North 6th St.	<b>OREGON</b>
<b>ARIZONA</b>	<b>MARYLAND</b>	* † Eugene 97401 . . . . . 1170 Pearl St.
* † Phoenix 85012 . . . . . 3550 N. Central Ave.	* † Baltimore 21201 . . . . . 1 N. Charles St.	* † Portland 97210 . . . . . 2929 NW 29th Ave.
† Tucson 85716 . . . . . 151 S. Tucson Blvd.	<b>MASSACHUSETTS</b>	<b>PENNSYLVANIA</b>
<b>ARKANSAS</b>	* † Wellesley 02181 . . . . . 1 Washington St.	* Allentown 18102 . . . . . 1144 Hamilton St.
† North Little Rock 72119 . . . . . 120 Main St.	<b>MICHIGAN</b>	* † Philadelphia 19102 . . . . . 3 Penn Center Plaza
<b>CALIFORNIA</b>	* † Detroit 48202 . . . . . 700 Antoinette St.	* † Pittsburgh 15222 . . . . . 300 6th Avenue Bldg.
* † Los Angeles 90054 . . . . . 212 N. Vignes St.	† Jackson 49201 . . . . . 210 W. Franklin St.	<b>SOUTH CAROLINA</b>
† Palo Alto 94303 . . . . . 960 San Antonio Rd.	† Saginaw 48607 . . . . . 1008 Second National Bank Bldg.	† Columbia 29204 . . . . . 2700 Middleburg Dr.
† Sacramento 95809 . . . . . 2407 J St.	<b>MINNESOTA</b>	† Greenville 29607 . . . . . 41 No. Pleasantsburg Dr.
† San Diego 92103 . . . . . 2560 First Ave.	* † Duluth 55802 . . . . . 300 W. Superior St.	<b>TENNESSEE</b>
* † San Francisco 94119 . . . . . 55 Hawthorne St.	* † Minneapolis 55416 . . . . . 1500 Lilac Drive So.	* † Chattanooga 37411 . . . . . 5800 Bldg, Eastgate Center
* † Vernon 90058 . . . . . 3035 E. 46th St.	<b>MISSOURI</b>	† Memphis 38130 . . . . . 3385 Airways Blvd.
<b>COLORADO</b>	* † Kansas City 64189 . . . . . 911 Main St.	<b>TEXAS</b>
* † Denver 80206 . . . . . 201 University Blvd.	* † St. Louis 63101 . . . . . 1015 Locust St.	* † Amarillo 79101 . . . . . 303 Polk St.
<b>CONNECTICUT</b>	<b>MONTANA</b>	* † Beaumont 77704 . . . . . 1385 Calder Ave.
* † Meriden 06450 . . . . . 1 Prestige Dr.	† Butte 59701 . . . . . 103 N. Wyoming St.	* † Corpus Christi 78401 . . . . . 205 N. Chaparral St.
<b>FLORIDA</b>	<b>NEBRASKA</b>	* † Dallas 75222 . . . . . 8101 Steinhilber Freeway
† Jacksonville 32203 . . . . . 4040 Woodcock Dr.	* † Omaha 68102 . . . . . 409 S. 17th St.	* † El Paso 79945 . . . . . 215 N. Stanton
† Miami 33134 . . . . . 4100 W. Flagler St.	<b>NEW JERSEY</b>	* † Fort Worth 76102 . . . . . 408 W. Seventh St.
* † Tampa 33609 . . . . . 2106 S. Lois Ave.	* † Millburn 07041 . . . . . 25 E. Willow St.	* † Houston 77027 . . . . . 4219 Richmond Ave.
<b>GEORGIA</b>	<b>NEW YORK</b>	† San Antonio 78204 . . . . . 434 S. Main St.
* † Atlanta 30309 . . . . . 1860 Peachtree Rd., NW	† Albany 12205 . . . . . 15 Computer Drive, West	<b>UTAH</b>
* † Savannah 31405 . . . . . 5002 Paulsen St.	* † Buffalo 14205 . . . . . 825 Delaware Ave.	† Salt Lake City 84111 . . . . . 431 E. Third East St.
<b>HAWAII</b>	* † New York 10022 . . . . . 641 Lexington Ave.	<b>VIRGINIA</b>
* † Honolulu 96813 . . . . . 440 Coral St.	* † Rochester 14604 . . . . . 89 East Ave.	* † Newport News 23601 . . . . . 311 Main St.
<b>ILLINOIS</b>	* † Syracuse 13205 . . . . . 3532 James St.	* † Richmond 23230 . . . . . 1508 Willow Lawn Dr.
* † Chicago 60680 . . . . . 840 S. Canal St.	<b>NORTH CAROLINA</b>	† Roanoke 24015 . . . . . 2018 Colonial Ave.
<b>INDIANA</b>	* † Charlotte 28207 . . . . . 141 Providence Rd.	<b>WASHINGTON</b>
† Evansville 47705 . . . . . 2709 Washington Ave.	* † Wilmington	* † Seattle 98186 . . . . . 112 Andover Parc East, Tukwila
† Fort Wayne 46807 . . . . . 3806 S. Calhoun St.	† Reigelwood 28456 . . . . . P. O. Box 186	† Spokane 99202 . . . . . E. 1805 Trent Ave.
* † Indianapolis 46207 . . . . . 3750 N. Meridian St.	<b>OHIO</b>	<b>WEST VIRGINIA</b>
<b>IOWA</b>	* † Cincinnati 45206 . . . . . 2621 Victory Pkwy.	* † Charleston 25328 . . . . . 306 MacCorkle Ave., SE
† Davenport 52805 . . . . . P. O. Box 630, 1039 State St., Bettendorf	* † Cleveland 44104 . . . . . 1000 Lakeside Ave.	<b>WISCONSIN</b>
<b>KENTUCKY</b>	† Columbus 43229 . . . . . 1110 Morse Rd.	* † Appleton 54911 . . . . . 3003 West College Dr.
† Louisville 40218 . . . . . 2300 Meadow Dr.	† Toledo 43606 . . . . . 3125 Douglas Rd.	† Milwaukee 53202 . . . . . 615 E. Michigan St.
	† Youngstown 44507 . . . . . 272 Indianola Ave.	

## GENERAL ELECTRIC SERVICE SHOPS

WHEN YOU NEED SERVICE ... These GE Service Shops will repair, recondition, and rebuild your electric apparatus. The facilities are available day and night, seven days a week, for work in the shops or on your premises. Latest factory methods and genuine GE renewal parts are used to maintain performance of your equipment. For full information about these services, contact your nearest service shop or sales office.

<b>ALABAMA</b>	<b>LOUISIANA</b>	<b>OKLAHOMA</b>
* Birmingham 35211 . . . . . 1500 Mims Ave., S. W.	* Baton Rouge 70814 . . . . . 10955 North Dual St.	* Tulsa 74145 . . . . . 5220 S. 100th East Ave.
* Mobile 36609 . . . . . 721 Lakeside Dr.	* New Orleans 70114 . . . . . 1115 DeArmas St.	<b>OREGON</b>
<b>ARIZONA</b>	<b>MARYLAND</b>	* Eugene 97402 . . . . . 570 Wilson St.
* (Phoenix) Glendale 85019 . . . . . 4911 W. Colter St.	* Baltimore 21230 . . . . . 920 E. Fort Ave.	* Portland 97210 . . . . . 2727 NW 29th Ave.
* Phoenix 85019 . . . . . 3840 W. Clarendon St.	<b>MASSACHUSETTS</b>	<b>PENNSYLVANIA</b>
* Tucson 85713 . . . . . 2942 So. Palo Verde Ave.	* Boston Medford 02155 . . . . . 3960 Mystic Valley Pkwy.	* Allentown 18103 . . . . . 668 E. Highland St.
<b>CALIFORNIA</b>	<b>MICHIGAN</b>	* (Delaware Valley) Cherry Hill, N. J. . . . . 08034
* Los Angeles 90301 . . . . . 6900 Stanford Ave.	* Detroit Riverview . . . . . 18075 Krause Ave.	* Johnstown 15802 . . . . . 1790 E. Marlon Pike
* (Los Angeles) Anaheim 92805 . . . . . 3801 E. LaPalma Ave.	* Flint 48505 . . . . . 1506 E. Carpenter Rd.	* Philadelphia 19124 . . . . . 1040 East Erie Ave.
* (Los Angeles) Inglewood 90301 . . . . . 228 W. Florence Ave.	<b>MINNESOTA</b>	* (Pittsburgh) West Mifflin 15122 . . . . . 4930 Buttermilk Hollow Rd.
* Sacramento 95814 . . . . . 99 North 17th St.	* Duluth 55807 . . . . . 50th Ave. W & St. Louis Bay	* York 17403 . . . . . 54 N. Harrison St.
* (San Francisco) Oakland 94608 . . . . . 1650 34th St.	* Minneapolis 55430 . . . . . 2025 49th Ave., N.	<b>SOUTH CAROLINA</b>
<b>COLORADO</b>	<b>MISSOURI</b>	* (Charleston) No. Charleston 29401 . . . . . 2490 Debonair St.
* Denver 80205 . . . . . 3353 Larimer St.	* Kansas City 64120 . . . . . 3525 Gardner Ave.	<b>TENNESSEE</b>
<b>CONNECTICUT</b>	* St. Louis 63110 . . . . . 1115 East Rd.	* Knoxville 37914 . . . . . 2621 Governor John Sevier Hwy.
* (Southington) Plantsville 06478 . . . . . 370 Atwater St.	<b>NEW JERSEY</b>	* Memphis 38107 . . . . . 708 North Main St.
<b>FLORIDA</b>	* New Brunswick 08902 . . . . . 3 Lawrence St.	<b>TEXAS</b>
* Jacksonville 32203 . . . . . 2020 W. Beaver St.	<b>NEW MEXICO</b>	* Beaumont 77705 . . . . . 1490 W. Cardinal Dr.
* (Miami) Hialeah 33010 . . . . . 1062 East 28th St.	* Albuquerque 87109 . . . . . 4420 McLeod Rd. NE	* Corpus Christi 78401 . . . . . 115 Waco St.
* Tampa 33601 . . . . . 19th & Grant Sts.	<b>NEW YORK</b>	* Dallas 75235 . . . . . 3202 Manor Way
<b>GEORGIA</b>	* Albany 12205 . . . . . 1097 Central Ave.	* Houston 77036 . . . . . 5534 Harvey Wilson Dr.
* (Atlanta) Chamblee 30341 . . . . . 5035 Peachtree Industrial Blvd.	* (Buffalo) Tonawanda 14150 . . . . . 175 Milens Rd.	* Houston 77036 . . . . . 6916 Harwin Dr.
* Atlanta . . . . . 2379 John Glenn Dr.	* (Long Island) Old Bethpage 11804 . . . . . 183 Bethpage-Sweet Hollow Rd.	* Midland 79701 . . . . . 704 S. Johnston St.
<b>ILLINOIS</b>	* (New York City) North Bergen, N. J. . . . . 07012	<b>UTAH</b>
* Chicago 60638 . . . . . 8045 S. Nottingham Ave.	* (New York City) Clifton, N. J. . . . . 07012	* Salt Lake City 84110 . . . . . 301 S. 7th West St.
<b>INDIANA</b>	* Schenectady 12305 . . . . . 9 Brighton Rd.	<b>VIRGINIA</b>
* Evansville 47711 . . . . . 401 N. Congress Ave.	* Syracuse 13208 . . . . . 1015 E. Hiawatha Blvd.	* Richmond 23224 . . . . . 1403 Ingram Ave.
* Ft. Wayne 46803 . . . . . 1731 Edsall Ave.	<b>NORTH CAROLINA</b>	* Roanoke 24013 . . . . . 1004 River Ave., SE
* Hammond 46320 . . . . . 1138 164th Place	* Charlotte 28208 . . . . . 2328 Thrift Rd.	<b>WASHINGTON</b>
* Indianapolis 46222 . . . . . 1740 W. Vermont St.	<b>OHIO</b>	* Seattle 98134 . . . . . 3422 First Ave., South
<b>IOWA</b>	* Akron (Canton) 44720 . . . . . 7900 Whipple Ave. N. W.	* Spokane 99211 . . . . . E. 4323 Mission St.
* (Davenport) Bettendorf 52722 . . . . . 1025 State St.	* Cincinnati 45202 . . . . . 444 West 3rd St.	<b>WEST VIRGINIA</b>
<b>KENTUCKY</b>	* Cleveland 44125 . . . . . 4477 East 49th St.	* Charleston 25328 . . . . . 306 MacCorkle Ave., SE
* Louisville 40209 . . . . . 3900 Crittenden Drive	* Columbus 43229 . . . . . 6680 Huntley Rd.	<b>WISCONSIN</b>
	* Toledo 43605 . . . . . 405 Dearborn Ave.	* (Appleton) Menasha 54910 . . . . . 1725 Racine St.
	* Youngstown 44507 . . . . . 272 E. Indianola Ave.	* Milwaukee 53207 . . . . . 235 W. Oklahoma Ave.