

C3 Ventless Submittal Information

1. Spec Sheet.....	1.1
2. UL Ventless Label.....	2.1
3. UL Listing.....	3.1
4. UL KNLZ Explained.....	4.1
5. C3 Emissions Test Results.....	5.1
6. Emissions by Product.....	6.1
7. Fire and Smoke Statement.....	7.1
8. C3 Energy Usage Estimate.....	8.1
9. Sampling of Letters from the Following States/Jurisdictions	9.1
California.....	9.1
North Carolina Department of Insurance.....	9.7
Wisconsin.....	9.9
Minnesota.....	9.11
Michigan.....	9.12
City of Saint Louis, MO.....	9.13
Miami County, OH.....	9.15
10. TurboChef Installation Recommendations	



Project _____

Item No. _____

Quantity _____



THE C3



PERFORMANCE

- The C3 roasts, browns and broils a wide variety of foods up to 10X faster, at a quality that meets or exceeds traditional cooking methods.

VENTILATION

- UL (KNLZ) listed for ventless operation.*
- EPA 202 test (8 hr):
 - Product: Pepperoni Pizzas
 - Results: 1.35 mg/m³
 - Ventless Requirement: <5.00 mg/m³
- Internal catalytic filtration to limit smoke, grease, and odor emissions.

EXTERIOR CONSTRUCTION

- 430 stainless steel front, top, sides and back
- 4" (102 mm) adjustable legs
- Powder coated handle
- Cool to the touch pull down door with microwave seal

INTERIOR CONSTRUCTION

- Fully insulated and sealed cook chamber
- 304 stainless steel liner with large radius corners
- 304 stainless steel removable grease collection pan

STANDARD FEATURES

- Integral recirculating catalytic converter system for UL (KNLZ) listed ventless operation
- Variable-speed High h recirculating impingement airflow system
- Bottom-launched microwave system
- Smart menu system capable of storing up to 128 recipes
- Built-in self-diagnostics for monitoring oven components and performance
- Stackable design (requires stacking kit)
- Includes plug and cord (6 ft. nominal)
- Smart card compatible
- Warranty – one year parts and labor

STANDARD ITEMS INCLUDED

- 1 Wooden Paddle (700-0673)
- 1 Bottle Oven Cleaner (103180)
- 1 Bottle Oven Guard (103181)
- 2 Trigger Sprayers (103182)
- 2 12x12 PTFE Screens (100014)
- 1 Ceramic Cooking Platter (TC3-3214)
- 1 Wave Guide Cap (TC3-3215)

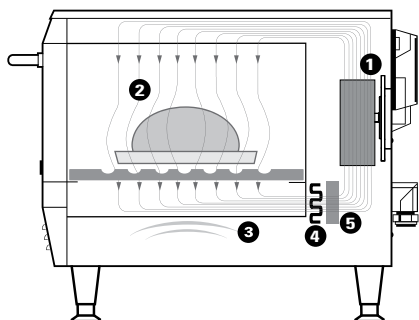

1. Blower Motor
2. Impinged Air
3. Microwave Bursts
4. Impingement Heater
5. Catalytic Converter



This product conforms to the ventilation recommendations set forth by NFPA96 using EPA202 test method.

* Ventless certification is for all food items except for foods classified as "fatty raw proteins." Such foods include bone-in, skin-on chicken, raw hamburger meat, raw bacon, raw sausage, steaks, etc. If cooking these types of foods, consult local HVAC codes and authorities to ensure compliance with ventilation requirements.

Ultimate ventless allowance is dependent upon AHJ approval, as some jurisdictions may not recognize the UL certification or application. If you have questions regarding ventless certifications or local codes please email ventless.help@turbochef.com

TurboChef reserves the right to make substitutions of components or change specifications without prior notice.

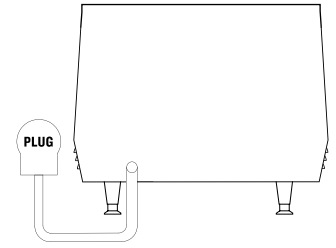
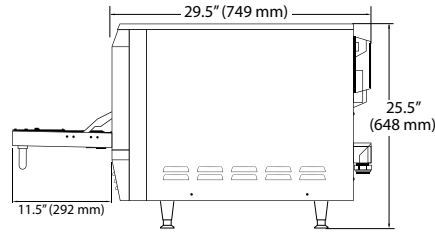
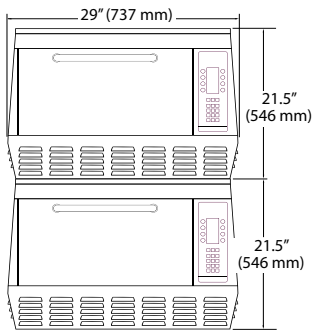

DIMENSIONS

Single Units		
Height	21.5"	546 mm
on legs	25.5"	648 mm
Width	29"	737 mm
Depth	29.5"	749 mm
with handle	32.25"	819 mm
Weight	255 lb.	116 kg
Stacked Units (Stacking Kit Required)		
Height	43"	1092 mm
Width	29"	737 mm
Depth	29.5"	749 mm
with handle	32.25"	819 mm
Weight	510 lb.	231 kg
Cook Chamber		
Height	7.1"	180 mm
Width	17.8"	452 mm
Depth	14.5"	368 mm
Volume	1.06 cu. ft.	30 liters
Wall Clearance (Oven not intended for built-in installation)		
Top	4"	102 mm
Sides	2"	51 mm

ELECTRICAL SPECIFICATIONS

NORTH AMERICA			
C3/D Single Model 50 Hz, 208 VAC (TC3-0605-1-208-1)			
C3/D Single Model 50 Hz, 240 VAC (TC3-0605-1-240-1)			
C3/D Single Model 60 Hz, 208 VAC (TC3-0605-1-208-2)			
C3/D Single Model 60 Hz, 240 VAC (TC3-0605-1-240-2)			
Phase	1 Phase		
Voltage	208 or 240 VAC		
Frequency	50 or 60 Hz		
Current	35/30 amp		
Max Circuit Requirement	50 amp		
Cord	3 wire (inc. ground)		
Plug	NEMA 6-50P (35 amp)		
Max Input	7.4 kW		
Microwave Input Power	2 kW		
EUROPE/ASIA-PACIFIC			
C3/D Multi Model 50 Hz (TC3-0605-1W)			
C3/D Multi Model 60 Hz (TC3-0605-1W-2)			
Phase	3 Phase		
Voltage	380-415 VAC		
Frequency	50 or 60 Hz		

Current	12 amp	
Max Circuit Requirement	20 amp	
Cord	5 Wire (inc. ground), 1.5m; H07RN-F	
Plug	IEC 309, 5 pin, 32 amp	
Max Input	7.4 kW	
Microwave Input Power	2 kW	
C3/D Multi Model 50 Hz (TC3-0605-1D)		
C3/D Multi Model 60 Hz (TC3-0605-1D-2)		
Phase	3 Phase	
Voltage	230 VAC	
Frequency	50 or 60 Hz	
Current	30 amp	
Max Circuit Requirement	32 amp	
Cord	4 Wire (inc. ground)	
Plug	IEC 309, 4 pin, 32 amp	
Max Input	7.4 kW	
Microwave Input Power	2 kW	
C3/D Single Model 50 Hz (TC3-0605-1K)		
C3/D Single Model 60 Hz (TC3-0605-1K-2)		
Phase	1 Phase	
Voltage	230 VAC	
Freq	50 or 60 Hz	
Current	30 amp	
Max Circuit Requirement	32 amp	
Cord	3 Wire (inc. ground), 1.5m, H07RN-F	
Plug	IEC 309, 3 pin, 32 amp	
Max Input	7.4 kW	
Microwave Input Power	2 kW	

SHIPPING INFORMATION

U.S.: All ovens shipped within the U.S. are packaged in a double-wall corrugated box banded to a wooden skid.
International: All International ovens shipped via Air or Less than Container Loads are packaged in wooden crates.

Box size: 37" x 32" x 33" (940 mm x 813 mm x 838 mm)
Crate size: 40" x 36" x 35" (1016 mm x 914 mm x 889 mm)
Item class: 85 NMFC #26770 HS code 8419.81

Approximate boxed weight: 325 lb. (147 kg)
Approximate crated weight: 400 lb. (181 kg)

Minimum entry clearance required for box: 32.5" (826 mm)
Minimum entry clearance required for crate: 35.5" (902 mm)

*All C3 multi-phase ovens can be field configured to allow single or 3 phase operation.
 **TurboChef recommends installing a type D circuit breaker for all installations.



LISTED
81Y5

**Commercial Microwave/Convection Oven
with Integral Systems for Limiting
the Emissions of Grease Laden Air**

**This Product Conforms to the Ventilation Recommendations
Set Forth by NFPA96 Using EPA202 Test Method**



KNLZ.E151487
Commercial Cooking Appliances with Integral Systems for Limiting the Emission of Grease-laden Air

[Page Bottom](#)

Commercial Cooking Appliances with Integral Systems for Limiting the Emission of Grease-laden Air

[See General Information for Commercial Cooking Appliances with Integral Systems for Limiting the Emission of Grease-laden Air](#)

TURBOCHEF TECHNOLOGIES INC

E151487

SUITE 105
4240 INTERNATIONAL PKY
CARROLLTON, TX 75007 USA

Commercial microwave/convection ovens, Models C3/C, HHB, NGC, i5.

[Last Updated](#) on 2008-02-14

[Questions?](#)

[Notice of Disclaimer](#)

[Page Top](#)

[Copyright © 2008 Underwriters Laboratories Inc.®](#)

The appearance of a company's name or product in this database does not in itself assure that products so identified have been manufactured under UL's Follow-Up Service. Only those products bearing the UL Mark should be considered to be Listed and covered under UL's Follow-Up Service. Always look for the Mark on the product.

UL permits the reproduction of the material contained in the Online Certification Directory subject to the following conditions: 1. The Guide Information, Designs and/or Listings (files) must be presented in their entirety and in a non-misleading manner, without any manipulation of the data (or drawings). 2. The statement "Reprinted from the Online Certifications Directory with permission from Underwriters Laboratories Inc." must appear adjacent to the extracted material. In addition, the reprinted material must include a copyright notice in the following format: "Copyright © 2008 Underwriters Laboratories Inc.®"

An independent organization working for a safer world with integrity, precision and knowledge.





KNLZ.GuideInfo

Commercial Cooking Appliances with Integral Systems for Limiting the Emission of Grease-laden Air

[View Listings](#)

[Page Bottom](#)

[Heaters and Heating Equipment] (Heaters, Cooking Appliances) Commercial Cooking Appliances with Integral Systems for Limiting the Emission of Grease-laden Air

[See General Information for Heaters, Cooking Appliances](#)

This category covers cooking equipment intended for commercial use, such as pressurized deep fat fryers and other appliances for use in commercial kitchens, restaurants or other business establishments where food is prepared. Each appliance covered in this category is manufactured with an integral system feature to limit the emission of grease-laden air from the cooking process to the room ambient.

These appliances have been evaluated for the limit of 5 mg/m³ for the emission of grease-laden air to the room ambient in accordance with the recommendations of the National Fire Protection Association Standard for Ventilation Control and Fire Protection of Commercial Cooking Operations, NFPA 96, using the EPA-202 test method prescribed for cooking appliances provided with integral recirculating air systems.

These products are not intended for connection to a ducted exhaust system.

Appliances in this category are not provided with an integral fire extinguishing system. Authorities having jurisdiction should be consulted as to the requirements for this equipment with respect to fire extinguishing systems, such as the need for field installed systems in accordance with NFPA 96.

For products with integral recirculating systems including fire extinguishing systems, refer to Commercial, with Integral Recirculating Systems ([KNKG](#)).

In cases where the nature or construction of equipment is such that special precautions beyond the requirements of the National Electrical Code must be observed in installations or use, suitable warning or special instructions are marked on the equipment.

Appliances Listed in this category are suitable for wiring with either copper or aluminum power supply conductors unless marked "Use Copper Wire Only For Power Supply Connections" .

Commercial cooking appliances of certain types are designed for permanent connections to water supply and sewer lines at the point of installation. Authorities having jurisdiction should be consulted as to the requirements for this equipment with respect to sanitation and connection to water supply and waste disposal lines.

Neither the toxicity of coatings nor the physiological effects on persons consuming food products prepared by use of these appliances has been investigated.

For cooking oil filters that are not an integral part of another appliance, see Commercial Filters for Cooking Oil ([KNRF](#)).

For additional information, see Electrical Equipment for Use in Ordinary Locations ([AALZ](#)) and Heating, Cooling, Ventilating and Cooking Equipment ([AAHC](#)).

The basic standard used to investigate products in this category is [ANSI/UL 197](#), "Commercial Electric Cooking Appliances".

Appliances Listed in this category with an integral cooking oil filter have been additionally investigated to the requirements in the standard "Commercial Filters for Cooking Oil", [ANSI/UL 1889](#).

The Listing Mark of Underwriters Laboratories Inc. on the product is the only method provided by UL to identify products manufactured under its Listing and Follow-Up Service. The Listing Mark for these products includes the name and/or symbol of Underwriters Laboratories Inc. (as illustrated in the Introduction of this Directory) together with the word "LISTED," a control number and one of the following product names as appropriate: "Commercial Cooking Appliance," "Cooking Appliance," or other appropriate product identity specified in the individual Listing, along with the words "with integral system for limiting the emission of grease-laden air. "

[Last Updated](#) on 1999-02-19

[Questions?](#)

[Notice of Disclaimer](#)

[Page Top](#)

[Copyright © 2008 Underwriters Laboratories Inc.®](#)

The appearance of a company's name or product in this database does not in itself assure that products so identified have been manufactured under UL's Follow-Up Service. Only those products bearing the UL Mark should be considered to be Listed and covered under UL's Follow-Up Service. Always look for the Mark on the product.

UL permits the reproduction of the material contained in the Online Certification Directory subject to the following conditions: 1. The Guide Information, Designs and/or Listings (files) must be presented in their entirety and in a non-misleading manner, without any manipulation of the data (or drawings). 2. The statement "Reprinted from the Online Certifications Directory with permission from Underwriters Laboratories Inc." must appear adjacent to the extracted material. In addition, the reprinted material must include a copyright notice in the following format: "Copyright © 2008 Underwriters Laboratories Inc.®"

An independent organization working for a safer world with integrity, precision and knowledge.



**Particulate Matter Emissions for
TurboChef Oven Model C3**

Application of EPA Method 202
Summary Report

**Food Service Technology Center
Manager: Don Fisher**

June 2002

Prepared by:

**Victor Kong
Fisher-Nickel Inc.**

Contributors:

**Angelo Karas
Scott Miner
Clem DaSilva
Vilma Balbuena**

Prepared for:

**James Pool
TurboChef Technologies, Inc.
10500 Metric Drive, Suite 128
Dallas, TX 75243**

Policy on the Use of Food Service Technology Center Test Results and Other Related Information

The Food Service Technology Center (FSTC) is *strongly* committed to testing food service equipment using the most appropriate scientific techniques and instrumentation.

The FSTC is neutral as to fuel and energy source. It does not, in any way, encourage or promote the use of any fuel or energy source nor does it endorse any of the equipment tested at the FSTC.

FSTC test results are made available to the general public through both Pacific Gas & Electric Company technical research reports and publications and are protected under U.S. and international copyright laws.

In the event that FSTC data are to be reported, quoted, or referred to in any way in publications, papers, brochures, advertising, or any other publicly available documents, the rules of copyright must be strictly followed, which includes written permission from Pacific Gas & Electric Company *in advance* and providing proper attribution to Pacific Gas & Electric Company and the Food Service Technology Center. In any such publication, sufficient text must be excerpted or quoted so as to give full and fair representation of findings as reported in the original documentation from FSTC.

Legal Notice

This report was prepared by Pacific Gas and Electric Company. Neither Pacific Gas and Electric Company nor any of its employees:

- (1) makes any written or oral warranty, expressed or implied, including, but not limited to those concerning merchantability or fitness for a particular purpose;
- (2) assumes any legal liability or responsibility for the accuracy, completeness, or usefulness of any information, apparatus, product, process, method, or policy contained herein; or
- (3) represents that its use would not infringe any privately owned rights, including, but not limited to, patents, trademarks, or copyrights.

TurboChef Model C3 Summary Report

The Food Service Technology Center (FSTC) tested the TurboChef Model C3 electric oven to determine the quantity of particulate matter (PM) emissions produced during the baking of pepperoni pizza under a full-load cooking scenario. Testing was performed under UL supervision in accordance with EPA Method 202¹ under the guidelines of UL 197, *UL Standard for Safety for Commercial Electric Cooking Appliances*, and UL guide KNLZ.² The oven operates on the principles of hot air convection combined with microwave energy and uses a proprietary catalytic grease filtration system to reduce cooking emissions. The main objective of this test was to measure the total quantity of particulate matter produced during the cooking process expressed as a concentration (mg/m^3). From the measured total emissions concentration, a total emissions rate, expressed in pounds of PM per hour (lb/h), can be determined for any specified hood's airflow rate. Furthermore, these emission concentrations can also be normalized to the amount of food cooked and expressed as an emissions factor for pounds of PM per thousand pounds of food cooked (lb PM/ Mlb food).



Figure ES-1.
TurboChef C3 inside test hood.

The 8-hour emissions test of the TurboChef C3 took place in the FSTC emissions test cell under a dedicated test hood that ensured capture and containment of the convective plume and all PM emissions (see Figure ES-1). The exhaust fan, which operated at a low volumetric flow rate of 200 cfm, was located approximately 120 inches from the entrance of the stack. The sampling probe was placed exactly 8 stack diameters above the entrance of the stack per UL 197 specifications and continuously drew samples at an isokinetic flow rate (preserved particulate matter velocity) to the sampling apparatus. A diagram of

¹ Environmental Protection Agency (EPA), *Method 202-Determination of Condensable Particulate Emissions from Stationary Sources, Emission Measurement Technical Information Center Test Method*, prepared by Emissions Branch, Technical Support Division, OAQPS, EPA, 1991.

² Underwriters Laboratories' UL KNLZ.GuideInfo, *Commercial, with Integral Systems for Limiting the Emission of Grease Laden Air*, contains the same certification criteria as UL 197, *Standard for Safety for Commercial Electric Cooking Appliances*, but applies the $5 \text{ mg}/\text{m}^3$ total PM concentration limit more specifically to appliances with integrated systems that limit the emission of grease laden air.

TurboChef Model C3 Summary Report

the emissions test cell is shown in Figure ES-2 and includes hood specifications and oven placement during the test.

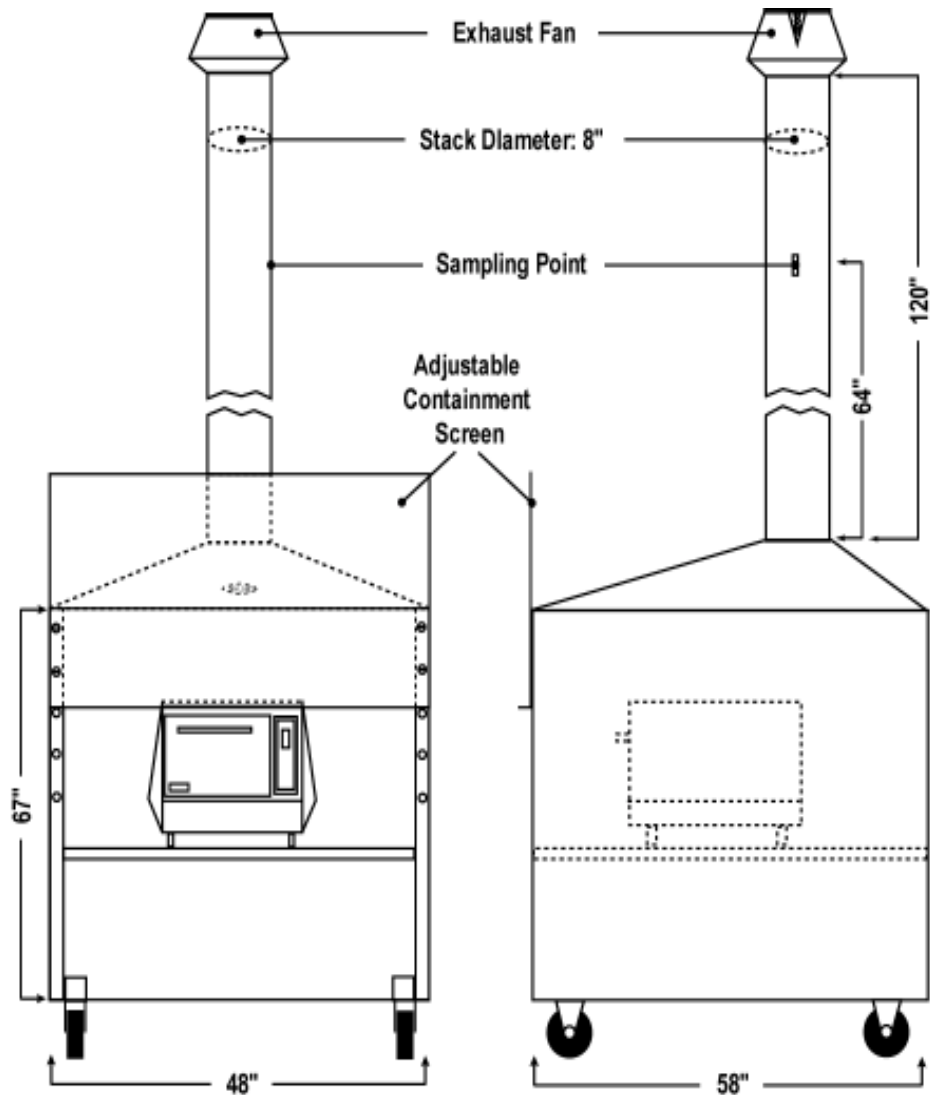

Figure ES-2.
Emissions Test Cell.

The TurboChef C3 oven operated consistently during the 8-hour test and produced a total condensable PM emissions concentration of 3.84 mg/m^3 , at a test ventilation rate of 200 cfm, which is less than the UL 197 / UL KNLZ condensable PM limit of 5.0 mg/m^3 . A summary of the test results is presented in Table ES-1. The measured PM concentration of 3.84 mg/m^3 at 200 cfm of

TurboChef Model C3 Summary Report

exhaust flow translates into an absolute emissions rate of 0.003 lb/h. An emissions factor of 0.08 lb of PM/ Mlb of food was also determined from the findings. Furthermore, if placed under a typical exhaust hood with an applied ventilation rate of 900 cfm, the TurboChef Model C3 would have only produced 0.85 mg/m³ of total particulate matter.

Test Results

*Table ES-1.
Emissions Measurements for the TurboChef, Model C3 Electric Oven.*

Sampling Period (minutes).....	480
<i>PM Concentration at the Test Ventilation Rate of 200 cfm</i>	
Total PM Concentration (mg/m ³).....	3.84
<i>Particulate Matter Emission Factor</i>	
Pounds of PM Produced per Thousand Pounds of Food Cooked (lb/Mlb)	0.08
<i>Particulate Matter Production Rate</i>	
Pounds of PM Produced per Hour (lb/h)	0.003

<i>PM Concentration at an applied Ventilation Rate of 900 cfm</i>	
Total PM Concentration (mg/m ³).....	0.85

With respect to the applied cooking scenario of this study, the TurboChef Model C3 electric oven, with its low emission rate, is eligible for operating without the benefit of a dedicated Type I exhaust hood. When compared to a re-circulating appliance/hood system listed under UL 197, the C3 emitted below the allowable concentration of 5.0 mg/m³ for condensable PM. The C3 emitted a total PM concentration of 3.84 mg/m³ at an applied ventilation rate of 200 cfm over the course of the 8-hour test, which also conforms to the criteria specified under the UL KNLZ classification.

Test Parameters

Tables ES-2 and ES-3 summarize the food product specifications and cooking parameters during the course of the emissions testing. Table ES-4 outlines the constant test conditions during the 8-hour test.

Table ES-2. Food Product Specifications

Test Food Product	Pepperoni Pizza
Number of Pepperoni per Pizza.....	24
Sauce Weight (lb).....	0.25
Cheese Weight (lb).....	0.375
Average Par Baked Pizza Crust Weight (lb)	0.886
Average Total Weight of Each Pizza (lb)	1.60

Table ES-3. Cooking Parameters

Cook Time (minutes)	2.0
Loading Time (minutes).....	0.25
Removal Time (minutes).....	0.25
Total Cooking Cycle (minutes).....	2.50
Pre-Cooking State (°F).....	40.0 ± 2.0
Number of Pizza	182
Production Rate (lb/h)	36.6

Table ES-4. Test Conditions

Sampling Time (minutes).....	480
Exhaust Duct Ventilation Rate (cfm)	200
Number of Probe Sampling Points.....	3
Time Interval at Each Sampling Point (minutes)	30.0

References

1. Underwriters Laboratories, Inc., *UL Standard for the Safety for Commercial Cooking Appliances, UL 197, 8th Edition*, Northbrook, IL, 1993.
2. Environmental Protection Agency (EPA), *Method 202-Determination of Condensable Particulate Emissions from Stationary Sources, Emission Measurement Technical Information Center Test Method*, prepared by Emissions Branch, Technical Support Division, OAQPS, EPA, 1991.
3. Bell, Todd, *Particulate Matter Emission for a TurboChef Oven, Model C3*, Application of EPA Method 202, Proprietary FSTC Report PR.0101.02, 2001.

UL (KNLZ) Emissions by Product

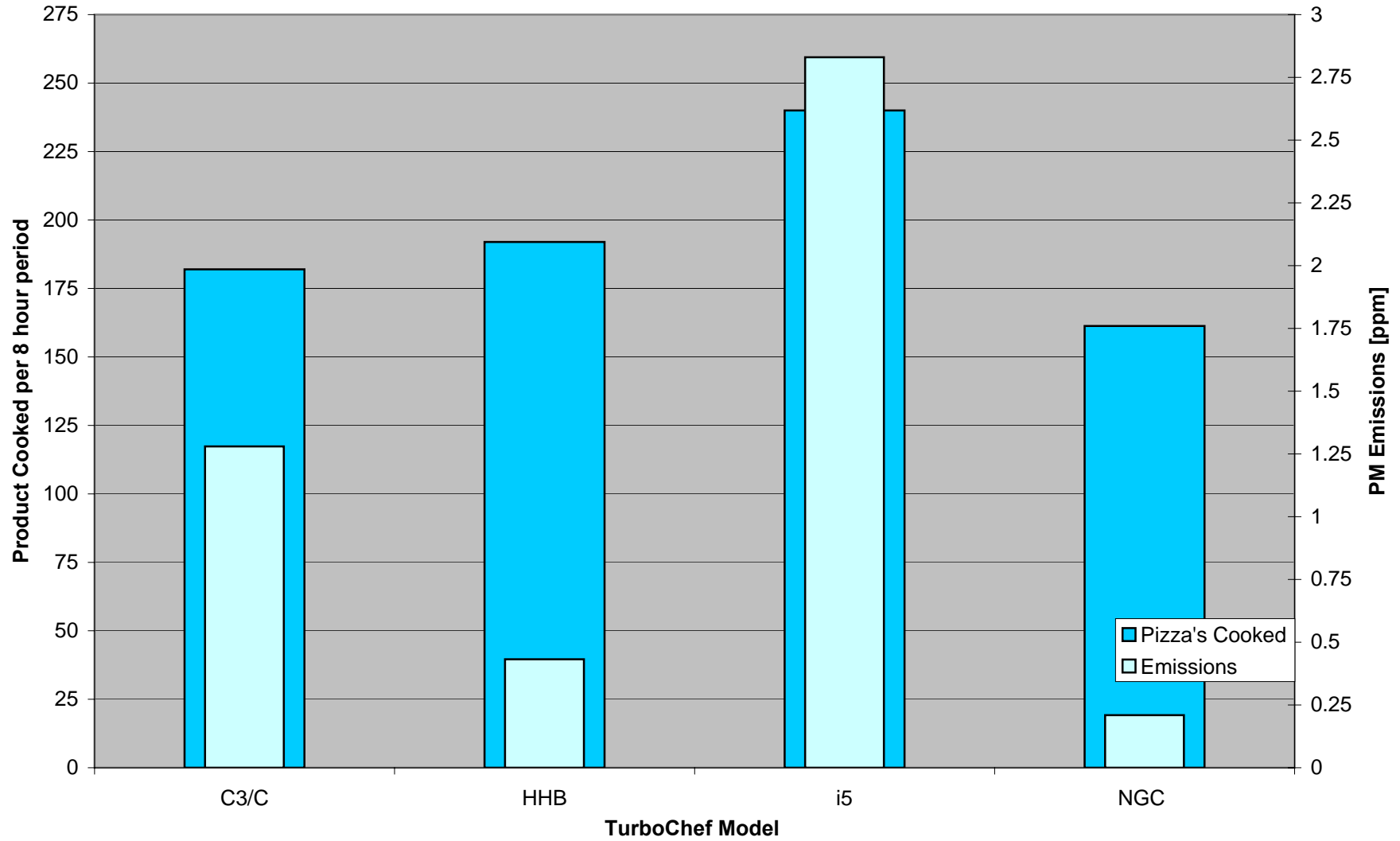



October 18, 2004

Mr. Mike Denny
 Building Services,
 224 West Knight St.
 City of Sioux Falls,
 South Dakota, 57102
 Ph: 605-367-8252

Re: Fire and smoke containment

Dear Mr. Denny:

The TurboChef ovens have been extensively tested and conform to UL 923 and UL KNLZ standards. The UL 923 standard is the electrical/product safety standard and the KNLZ is the low particulate matter emissions standard to which we conform. While both standards address different aspects of the oven, they both have inherent overlap as it relates to grease/smoke/fire handling.

As it relates specifically to fire safety, UL 923 specifies:

Section 57 Cavity Fire Containment Test:

The performance of an appliance subjected to this test shall be considered acceptable if all of the following conditions are met:

- a) There is no emission of fire, flame, or molten metal outside the appliance nor glowing or ignition of the cheesecloth, tissue paper, or wood surface;*
- b) The fuse rated 3 A does not open;*
- c) Following the test, the appliance complies with the requirements of Leakage Current, Section 33, and Dielectric Voltage-Withstand Test, Section 39, as applicable to primary circuits; and*
- d) Following the test and following 10 c of operation (opening and closing the door), the appliance complies with the requirements in 57.12. The radiation emission shall not exceed 5mW/cm².*

Test Method:

Section 57.2 requires that 4 potatoes each weighing between 150g and 200g be placed inside the oven under test and cooked using full microwave power and hot air (if applicable) until the potatoes catch fire. Note: The test must be repeated until it catches fire. During this test, pieces of tissue paper and cheesecloth are placed above, below and around the product to ensure that the fire and/or excessive heat generated is safely contained within the confines of the appliance.

As it relates to grease handling, UL KNLZ specifies:

UL KNLZ Guide Information Excerpt:

"These appliances have been evaluated for the limit of 5 mg/m³ for the emission of grease-laden air to the room ambient in accordance with the recommendations of the National Fire Protection Association Standard for Ventilation Control and Fire Protection of Commercial Cooking Operations, NFPA 96, using the EPA-202 test method prescribed for cooking appliances provided with integral recirculating air systems."

Test Method:

The UL KNLZ category requires that products must have less than 5.0 mg/m³ of particulate matter emissions during 8 continuous hours of cooking a "worst case" food product as measured by EPA 202. Note: Our products were tested using full-fat pepperoni pizzas.

As it pertains specifically to smoke: Smoke typically consists of visible grease particulate that escapes from a product during operation. Our ovens utilize a recirculating airpath that is catalytic scrubbed, thus the airborne grease is combusted as it crosses our catalyst. Given this, under typical/normal operating conditions, our product does not emit smoke.

If you have any issues or specific questions regarding the above, please contact me directly.

Best regards,

James K. Pool III

James K. Pool III
Vice President Engineering,
TurboChef Technologies, Inc.,
Ph: 214.379.6020
Email: james.pool@turbochef.com

C3/C (1 OR 3 PHASE)



Changeable Parameters		
Operating Time	12	Hours
Energy Costs	\$0.11	kWHr
Snooze Mode	0.00	Hours
Cook Cycles/Day	90	Cooks/Day
Typical Cook Time	90	Seconds

Do Not Change the following values

	Time (min)	Power (Watts)	Cost/Day	Balance of Time (hrs)
Warm up	15	5100	\$0.14	11.75
Cooking	135	6100	\$1.51	9.50
Snooze Idle	0	0	\$0.00	9.50
Idle	570	1100	\$1.15	0
Total/Day			\$2.80	Yearly
Total/Month			\$83.99	\$1,007.82

HVAC Requirements Per Operating Time -- Note: Approximations Only					
Average Energy Cooking And Idle (J)	Warmup Energy (J)	Total Energy (J)	Total average Power (W)	Total Environmental Load kBtu/hr	Average Cooling Requirement (ton of AC)
87030000	4590000	91620000	2121	7	0.603



SANDRA SHEWRY
Director

State of California—Health and Human Services Agency
Department of Health Services



ARNOLD SCHWARZENEGGER
Governor

July 23, 2004

Ruth Sender
OhCal Foods, Inc.
20501 Ventura Blvd., Suite 375
Woodland Hills, CA 91364

RE: Exemption from Mechanical Exhaust Ventilation for
TurboChef Model NGC Rapid Cook Oven

Dear Ms. Sender:

Thank you for your application of April 26, 2004, for a review of the TurboChef Model NGC Rapid Cook Oven for exemption from the mechanical exhaust ventilation requirements of Section 114140 of the California Uniform Retail Food Facilities Law (CURFFL). Specifically, you have requested an exemption to allow unventilated NGC Rapid Cook Ovens to be installed and operated at various Subway locations throughout California.

You have provided documentation and I have verified that the TurboChef Model NGC Rapid Cook Oven has been evaluated and listed by UL for conformance with ANSI/NSF Standard 4.

Under the provisions of CURFFL Section 114140, the Department may exempt heating and cooking equipment that does not produce toxic gases, grease, smoke, or heat when properly installed and operated as recommended by the manufacturer. Based on the information and documentation you have provided, the TurboChef Model NGC Rapid Cook Oven is granted LIMITED exemption from mechanical exhaust ventilation under the following conditions:

1. Unless approval is granted by the local enforcement agency, there shall be no more than one unventilated oven in operation at each Subway location.
2. No other heating or cooking appliances subject to mechanical ventilation requirements may be operated without mechanical ventilation in the food facility, unless permission to operate more than one unventilated appliance is granted by the local enforcement agency.

Ms. Ruth Sender
July 23, 2004
Page 2

3. The oven shall not be used for cooking meats, poultry, fish, or other foods that may produce grease laden vapors. Such use will require that mechanical ventilation be installed over the unit.
4. The oven must be operated and installed in a well-ventilated area approved for food preparation.
5. The oven must be installed, maintained, operated, and serviced according to the specifications of the manufacturer and local codes.
6. This exemption shall not be deemed to supersede any local fire or building code requirements.

This exemption shall be in effect until revoked. However, should any local enforcement agent find that the operation of the TurboChef Model NGC Rapid Cook Oven without mechanical ventilation creates a sanitation or safety problem, the local enforcement agent may require the unit to be used only with mechanical ventilation. These problems may include, but are not limited to, problems of installation, use, maintenance, cleaning or other site specific considerations which exceed the above limitations or pose a discernable health or safety hazard.

This letter may be used as evidence of the evaluation of the TurboChef Model NGC Rapid Cook Oven. However, it is not to be construed as an endorsement of the subject item and may not be used for advertising or promotional purposes.

If you have any questions you may call me at (916) 650-6617.

Sincerely,

Susan Strong, REHS
Program Specialist, Retail Food Unit

Cc: Mike Boian, REHS
Northern California Technical Advisory Committee

Ms. Ruth Sender
July 23, 2004
Page 3

Virginia Lineberry, REHS
Bay Area Technical Advisory Committee

Donna Fenton, REHS
Central Valley Technical Advisory Committee

Nelson Kerr, REHS
Southern California Technical Advisory Committee

Gary Erbeck, REHS
CCDEH, Food Safety Policy Committee



California
Department of
Health Services
DIANA M. BONTÁ, R.N., Dr. P.H.
Director

State of California—Health and Human Services Agency
Department of Health Services
Food & Drug Branch



GRAY DAVIS
Governor

October 25, 2002

Peter J. Ashcraft
TurboChef Technologies, Inc.
10500 Metric Drive, Suite 128
Dallas, Texas 75243

Dear Mr. Ashcraft:

RE: Exemption from External Mechanical Exhaust Ventilation

Thank you for your letter of October 7, 2002 requesting exemption from mechanical exhaust ventilation requirements specified in Section 114140 of the California Uniform Retail Food Facilities Law (CURFFL) for the Model C3/C Rapid Cook Oven.

Descriptive materials and cut sheets accompanying your application specify that this oven is Sanitation Classified by NSF International for compliance with ANSI/NSF Standard 4 for commercial heating and cooking appliances.

Under the provisions of Section 114140, the Department may exempt heating and cooking equipment that does not produce toxic gases, grease, smoke, or heat when properly installed and operated as recommended by the manufacturer. Results of tests conducted by the Pacific Gas & Electric, Food Service Technology Center, indicate that the oven produces no significant emissions of smoke and grease-laden air while in use. Based on the information you have provided and the certifications by recognized testing laboratories, the TurboChef Technologies Model C3/C Rapid Cook Oven is granted LIMITED exemption from mechanical ventilation requirements under the following conditions:

1. There may be up to two (2) unventilated Model C3/C ovens in Subway sandwich stores in California.
2. The oven(s) must be installed, maintained, operated, and serviced according to the specifications of the manufacturer and local codes.
3. Any modification, alteration, or removal of any component of the integral air filtration system voids this limited exemption.
4. All air filtration components must be installed and operational at all times the appliance is in use.
5. The oven must be installed in an approved food preparation area with sufficient room ventilation to maintain acceptable working conditions.



Do your part to help California save energy. To learn more about saving energy, visit the following web site:

www.consumerenergycenter.org/flex/index.html

Peter Ashcraft
October 25, 2002

This exemption shall be in effect until revoked. However, should any local enforcement agent find that the operation of the TurboChef Technologies Model C3/C Rapid Cook Oven without mechanical ventilation creates a sanitation or safety problem, the local enforcement agent may require the unit to be used only with external mechanical ventilation. These problems may include but are not limited to problems of installation, use, maintenance, cleaning or other site specific considerations which exceed the above limitations or pose a discernable health or safety problem.

This letter may be used as evidence of the evaluation of the TurboChef Model C3/C Rapid Cook Oven. However, it is not to be construed as an endorsement of the subject equipment and may not be used for advertising or promotional purposes.

If you have any questions you may call me at (916) 327-6905.

Sincerely,

Jeffrey C. Lineberry, MPH
Chief, Retail Food Unit

Cc: Mike Boian, REHS
Northern California Technical Advisory Committee
Butte County Environmental Health
P.O. Box 5364
Chico, CA 95927

Leslie Gentry, REHS
Bay Area Technical Advisory Committee
Solano County Environmental Health
601 Texas Street
Fairfield, CA 94533

Donna Fenton
Central Valley Technical Advisory Committee
Environmental Health Services
2700 "M" Street, Suite 300
Bakersfield, CA 93301

Peter Ashcraft
October 25, 2002

Elizabeth Quaranta
Southern California Technical Advisory Committee
San Diego County Environmental Health
1255 Imperial Avenue
San Diego, CA 92101

Gary Erbeck, Food Policy Committee
California Conference of Directors of Environmental Health
San Diego County Environmental Health
1255 Imperial Avenue
San Diego, CA 92101

NORTH CAROLINA
DEPARTMENT OF INSURANCE

Jim Long
Commissioner of Insurance
State Fire Marshal

ENGINEERING

January 4, 2006

Mr. Tom Johnson
President, JDP, Inc.
1408 Northland Drive
Suite 407
Mendota Heights, MN 55120-1013

RE: TurboChef Model HHB

Dear Mr. Johnson:

I have received your request to have TurboChef model HHB ovens placed in Subway restaurants in the state of North Carolina without requiring the installation of a Type I or Type II hood above the appliance. I have reviewed the information you submitted with your request. On February 15, 2005, I wrote a letter allowing the use of Models C3 and NGC ovens to be used in Subway restaurants or other similar type establishments. A copy of the February 15, 2005, is enclosed. The requirements and approvals stated in the February 15, 2005, will also apply to the Model HHB.

If you have any further questions, feel free to contact me.

Sincerely,

Wanda D. Edwards, PE
Deputy Commissioner
Office of the State Fire Marshal
NC Department of Insurance

Enclosure

cc: Phil Edwards, Mecklenburg County Inspections
Members of the Building Code Council



NORTH CAROLINA
DEPARTMENT OF INSURANCE

Jim Long
Commissioner of Insurance
State Fire Marshal

ENGINEERING

February 15, 2005

Mr. Thomas W. Johnson
1408 Northland Drive
Suite 407
Mendota Heights, MN 55120-1013

Re: Turbo-Chef Convection/Microwave Oven Models C3 and NGC

Dear Mr. Johnson:

You requested consideration of the Turbo-Chef oven models C3 and NGC to be placed in Subway restaurants in the state of North Carolina without requiring installation of a Type I or Type II hood above the subject appliance. Upon review of the submitted materials and inspection by our engineering staff at a local Subway restaurant where the subject appliance is in service, neither a Type I nor Type II hood is required to be placed above the subject equipment in a Subway restaurant or similar establishment. The equipment shall be installed, maintained, operated, and serviced according to the manufacturer's installation instructions. The equipment shall be installed in an approved food preparation area with sufficient room ventilation to maintain acceptable working conditions.

This equipment includes product listings to UL KNLZ. The proprietary catalytic technology engineered into this equipment limits emission of grease laden air to an acceptable level below 5 mg/m³ using the EPA-202 test method prescribed for cooking appliances provided with integral air recirculating systems.

Preparation in these ovens without ventilation by a local exhaust system shall be limited to pizzas, sub sandwiches, reheating of partially baked or cooked foods, other similar items, and baking. Cooking of raw, fatty protein products (i.e., raw meat) shall only be performed in these ovens according to recommendations by the manufacturer and when properly located under an appropriate local exhaust system.

If you have any questions, please contact me at (919) 661-5880 x-255.

Sincerely,

Wanda D. Edwards, PE
Deputy Commissioner
Office of the State Fire Marshal
NC Department of Insurance

WDE/jnw

cc: Members of the NC Building Code Council



Evaluation #

200424-H Revision 2

Safety & Buildings Division
 201 West Washington Avenue
 P.O. Box 2658
 Madison, WI 53701-2658

Wisconsin Building Products Evaluation

Material

Microwave Oven
 TurboChef Model NGC

Manufacturer

TurboChef Technologies, Inc.
 10500 Metric Dr., Suite 128
 Dallas, TX 75243

SCOPE OF EVALUATION

Section 507.2.2 of the **2003 and 2004 Supplement** of the **International Mechanical Code, IMC**, regarding exhaust system requirements where commercial cooking and dishwashing appliances produce grease, smoke, heat or steam have been evaluated for compliance with certain requirements of the **Wisconsin Commercial Building Code (WCBC), Chapters Comm 61-65**. Pursuant to **s. Comm 61.61** the TurboChef Models Tornado (NGC), C3/C and High H (HHB) microwave ovens are approved for use in the State of Wisconsin to satisfy the intent and the provisions of **IMC 507.2.2** as adopted by the **Wisconsin Commercial Building Code**.

This evaluation does not include the review for compliance to provisions of the current **Wisconsin Commercial Building Code** other than those specifically referenced above.

The use of the TurboChef Models Tornado (NGC), C3/C and High H (HHB) microwave ovens are subject to the description, limitations and conditions described in this evaluation.

DESCRIPTION AND USE

The current **Wisconsin Commercial Building Code** together with the 2000 edition of the **International Mechanical Code, IMC**, does not specifically address, acknowledge or prohibit the utilization of recirculating hoods and vent less steam removal systems in conjunction with commercial kitchen appliances and their operation where grease, smoke, heat or steam is produced. The revision under the **2003** edition and **2004 Supplement** of the **IMC** clarify the use of such appliances.

Section 507.2.2 of the **2003 International Mechanical Code** read as follows:

507.2.2 Type II hoods. Type II hoods shall be installed where cooking or dishwashing appliances produce heat or steam and do not produce grease or smoke, such as steamers, kettles, pasta cookers and dishwashing machines.

COMMERCE Product Evaluation No. 200424-H Revision 2

Page 2

Exception:

3. A single light-duty electric convection, bread, retherm or microwave oven designed for installation on a counter or that is enclosed on five sides in a counter, provided that such appliances do not increase the ambient temperature more than 10° F at a distance greater than 5 feet away from such appliance during operation.

LIMITATIONS OF APPROVAL

The evaluation number assigned to this approval is to accompany each plan submitted for projects that utilizes the TurboChef Models: Tornado (NGC), C3/C and High H (HHB) ovens.

Deviations from this approval shall void the use of the approval.

Pursuant to s. **Comm 61.61(7)**, the department may reexamine an approval and issue a revised approval at any time.

This approval will be valid through December 31, 2009, unless manufacturing modifications are made to the product or a re-examination is deemed necessary by the department. The product approval is applicable to projects approved under the current edition of the applicable codes. This approval may be void for project approvals made under future applicable editions. The Wisconsin Building Product Evaluation number must be provided when plans that include this product are submitted for review.

DISCLAIMER

The department is in no way endorsing or advertising this product. This approval addresses only the specified applications for the product and does not waive any code requirement not specified in this document.

Revision Date: March 22, 2006

Approval Date: September 30, 2004 By: _____
Lee E. Finley, Jr.
Product & Material Review
Integrated Services Bureau

200424-H.doc



Working Together to Promote Food Safety

DATE: June 11, 2004

TO: All Local Health Agencies
Minnesota Department of Health (MDH) EHS Sanitarians and Supervisors
Minnesota Department of Agriculture (MDA)

FROM: Colleen Paulus
Manager, MDH Environmental Health Services Section

Kevin Elfering
Director, MDA Meat, Food and Dairy Division

SUBJECT: Inter Agency Review Council Document 04-04V
TurboChef Tornado Oven Model NCG

Please distribute the attached information to sanitarians on your staff who work in the Food Program.

Attached please find IARC Guidance Document #04-04V regarding the new TurboChef Tornado Microwave/Convection Oven Model NCG that is being proposed in Subway Sandwich Shops throughout Minnesota. This document is very similar, *but not exactly the same* as IARC Document #03-01 issued April 9, 2003, which addresses the TurboChef Rapid Cook Oven Model No. C3. The emissions test for total particulate matter was much lower from the test conducted on the previous oven ($0.5\text{mg}/\text{m}^3$ vs. $3.8\text{ mg}/\text{m}^3$). However, as you will note in the attached conditions for acceptance, unless there is a sufficient amount of general ventilation existing in the space, additional cooling capacity may be needed and verified by a certified testing and balancing contractor.

If you have any questions regarding the TurboChef Tornado Oven Model NCG use, you may contact the Vent Committee Chair, Lorna Girard, at 651/296-1591 or at lorna.girard@state.mn.us

If you have any questions regarding the IARC, please contact Sue Hibberd at 651/215-0866 or at sue.Hibberd@health.state.mn.us



STATE OF MICHIGAN
DEPARTMENT OF AGRICULTURE
LANSING

JENNIFER M. GRANHOLM
GOVERNOR

DAN WYANT
DIRECTOR

April 14, 2004

Mr. James Boyd, Plan Review Specialist
Kent County Health Department
Environmental Health Division
700 Fuller Avenue, N.E.
Grand Rapids, MI 49503

Re: Turbo-Chef Convection / Microwave Oven Models C3/C and NGC

Dear Mr. Boyd:

You requested an evaluation of the Turbo Chef oven model NGC, that is proposed to be installed in Subway restaurants state-wide. MDA recommends that both model NGC and C3/C may be installed and used without ventilation in any food establishment as they are UL197SB listed. These ovens contain an internal filter and vent that has been shown, under proper test conditions, to emit very little grease (pepperoni pizzas were used in testing).

Preparation in these ovens without additional ventilation should be limited to pizzas, sub sandwiches, reheating of par-baked or cooked foods, other similar items and baking. Neither MDA nor the manufacturer recommends cooking raw, fatty protein products (i.e. raw meat) in these ovens.

Michigan's mechanical code rules (R 408.30935a) specifically exempt from ventilation "listed factory-built commercial cooking recirculating systems which are tested in accordance with UL 197" and installed per listing and manufacturer's directions. However, a mechanical inspector may require ventilation if the building has inadequate general ventilation.

If you have any questions please call me at (517) 373-2779.

Sincerely,

Kevin Besey, Supervisor
Food Service Sanitation Section
Food and Dairy Division

cc: James Pool, Turbo Chef
Dave Adams, Assistant Chief, Mechanical Division, BCC, MDCIS
Michigan local Health Departments / MDA Regions



Board of Building Appeals

City of St. Louis
 Room 400, City Hall
 1200 Market Street

Saint Louis, Missouri 63103 - 2850

622-3332

June 22, 2005

TURBO CHEF
 TOM JOHNSON
 1408 NORTHLAND DR STE 407
 MENDOTA HEIGHTS MN 55120-1013

RE: Board of Building Appeal 3723
 423 LYNCH
 WARD 9

Proceedings

On June 2, 2005, the Board of Building Appeals of the City of St. Louis met, pursuant to Section 121.0 of the Building Code, to consider Appeal 3723 from the determination of the Building Commissioner relative to complying with Sections 507.1 and 507.2 of the Mechanical Code for the premises at 423 Lynch.

Dave Thomas Johnson appeared in favor of this appeal.

James Kelly Poole appeared in favor of this appeal.

Mechanical Inspection Supervisor Jerry Corbin and Lead Mechanical Inspector Gene Miller represented the Building Commissioner.

The following items were presented to the Board and entered as evidence:

- a.) A violation letter dated 04-26-05
- b.) Appellant's appeal form
- c.) Certified copy of the Building Code, Ordinance 64771, and a certified copy of the Mechanical Code, Ordinance 65021

Findings of Fact

1.) Mr. Kelly Poole and Mr. Thomas Johnson appeared and stated they are requesting a variance from installing a Type II hood over a Turbo Chef microwave/convection oven, which would be installed according to manufacturers instructions, at Anheuser Busch and to allow the HVAC system installed to compensate for any sensible heat emissions from the equipment.

2.) They stated there are new provisions to model building codes which excludes some cooking processes as not requiring hoods, and that the Turbo Chef with its patented catalyst grease filtration system fits this category.

3.) The Turbo Chef equipment was tested under UL supervision using the UL KNLZ and UL 197 guidelines from UL and found to produce less than 5 mg/m³ particulate matter concentration for a hood flow rate of 200 cfm.

423 Lynch
 Appeal 3723
 Page 2

4.) This grease concentration is below any that would pose a fire hazard and therefore would not require a hood to capture and exhaust the grease.

5.) This equipment is also portable and does not fall into the category of permanent commercial heat processing appliances. New provisions being adapted by some model codes recognize that per each 100 s.f. of kitchen floor area, a Type II hood is not required for a single light-duty electric convection, bread, retherm or microwave oven provided it is less than 3 feet in outside dimensions. The Turbo Chef appliances fits into this category.

6.) The appliance does not emit effluent emissions above the threshold within EPA 202.

7.) Mr. Jerry Corbin and Mr. Gene Miller appeared and stated they were following the building code adopted by City and under those present provisions a Type II hood is required.

Conclusion of Law

The Board concludes that new provisions to model building codes are being incorporated to provide exceptions to installing Type II hoods over microwave/convection ovens which limit grease emissions to levels below a threshold that would present a fire hazard. Those provisions are not adopted by the City. The Board also concludes that the Turbo Chef appliances meets the requirements and has proven so with the UL rating for the equipment. Use of this appliance without a Type II hood does not present a fire safety hazard. Therefore, the Board grants the appeal as stated below.

Decision

It is the decision of the Board of Building Appeals that this appeal be granted.

By Order of the Board of Building Appeals,

 Lynn Wentz
 Secretary

CC: Building Commissioner
 Randy Mourning
 NSO
 Don Hubeli
 Frank Oswald
 Fire Marshal
 Court Section
 Central File
 Lenita Moore, SLDC
 Alan Schmidt

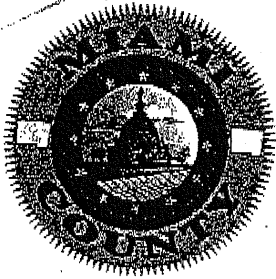

MIAMI COUNTY BUILDING REGULATIONS

510 W. Water Street, Suite 120 Troy, Ohio 45373
Phone (937) 440-8075 • 440-8066

ADDENDUM 2 TO PARTIAL PLAN APPROVAL

DATE: 12/30/05
PROJECT: TENANT BUILD OUT – W.G. GRINDERS
ADDRESS: 1260 EAST ASH ST.
PIQUA, OH 45356
PERMIT # 3014
APPROVAL DATE: 12/30/05

This PARTIAL PLAN APPROVAL is limited to the following:

ALL WORK EXCEPT SPRINKLER REVISIONS.

This is a PARTIAL PLAN APPROVAL in accordance with the provisions of Section 106.3.3 of the Ohio Building Code. The various stages of construction shall proceed in their normal sequence.

This addendum shall be attached to the Certificate of Plan Approval and shall become part of the approved plans. All items listed below will be performed and incorporated into the structure.

This PARTIAL PLAN APPROVAL is contingent upon the following:

1. The proposed project plans are sealed by: PETER MACRAE – ARCHT #9040. HVAC. PLUMBING. ELECTRICAL – JOHN SANDERS – P.E. #58219 to comply with Sections 106.3.4.1 and 105 OBC.
2. Construction Documents at project site:
An approved set of Construction Documents shall be kept at the site of the work and shall be available for reference by the building official or the building officials designated representative at all times during working hours while such work is in progress; Section 106.3.1 OBC.
3. The Board of Appeals Variance, Case #05-453, dated September 20, 2005 is a part of the permit Approval, (Building Permit #2835).
4. Install Fire Extinguishers per Section 906 (maximum travel distance = 75') Verify size and location with the local fire authority.
5. The letters from Thomas Johnson, President JDP, Inc. and the accompanying UL710 test data indicates that the Turbochef microwave / convection oven HHB complies with 2005 OMC Sections 507.2.1 exception 1 and 507.2.2 exception 3, when used and installed in accordance with the manufacturer's listing and instructions. Therefore a type I hood and fire suppression and a type II hood are not required. No cooking of raw fatty animal proteins is permitted. No other cooking appliances are permitted. The dishwasher equipment and installation shall comply with Section 507.2.2 exception 1 or 2 or a type II hood is required for heat and vapor removal. The HVAC system shall be designed for the additional heat and moisture loads generated by such appliances.

Page 2

The holder of a **PARTIAL PLAN APPROVAL** may proceed only to the point for which approval has been given, at his own risk and without assurance that approval for the entire building will be granted.

The citation of certain items in this document does not exempt the owner from the obligation to comply with all portions of the Ohio Revised Code, the OBC, local requirements or any other applicable Code. The Building Department reserves the right to cite additional requirements of the OBC upon further review or inspection of the project. You have the right to appeal listed interpretations or decisions in accordance with Section 3781.19 of the Ohio Revised Code. Contact this department for further information.

Plans Reviewed by: DAVID J. DURBIN/DJD ENG.

Chief Building Official:

Robert D. Bauman

Installation Recommendations

TurboChef ventless ovens have internal systems for destroying grease laden vapor prior to the grease escaping the oven; therefore, the ovens are certified as non-grease emitting appliances. When following our recommendations, TurboChef ovens can be installed without the aid of a Type I or Type II hood per International Mechanical Code (2006, 2009, and 2012), NFPA 96, NFPA 101 (Life Safety Code), EPA 202, and Underwriter’s Laboratory (UL KNLZ).

The following guide is intended to give relevant information for the ventless installation, operation, and maintenance of TurboChef ovens. It is important that these guidelines are followed and that the oven and surrounding areas be maintained regularly for optimal performance.

Certifications

Safety – cULus, TUV (CE)
 Sanitation – NSF, UL EPH^{*}
 Ventless – UL (KNLZ)



Electrical Requirements

TurboChef ovens must be installed on a circuit equal to the ratings listed below, per NEC sec 210.23, permissible loads.

Oven	Voltage	Current	Phase
Söta (i1)	208/240 VAC	30 amp	1 Ph
Söta Single Mag (i1)	208/240 VAC	20 amp	1 Ph
i3	208/240 VAC	40 amp	1 Ph
	208/240 VAC	30 amp	3 Ph
i5	208/240 VAC	50 amp	1 Ph
	208/240 VAC	30 amp	3 Ph
Encore/Encore 2	208/240 VAC	30 amp	1 Ph
Tornado	208/240 VAC	30 amp	1 Ph
C3	208/240 VAC	50 amp	1 Ph
HhC 2620	208/240 VAC	50 amp	3 Ph
HhC 2020	208/240 VAC	50 amp	3 Ph
HhC 1618	208/240 VAC	30 amp	3 Ph
	208/240 VAC	50 amp	1 Ph
HhB 2	208/240 VAC	30 amp	1 Ph
Double Batch	208/240 VAC	50 amp	1 Ph
	208/240 VAC	30 amp	3 Ph
Waterless Steamer (i1)	208/240 VAC	30 amp	1 Ph
Panini (i1)	208/240 VAC	30 amp	1 Ph
Fire	208/240 VAC	30 amp	1 Ph
Bullet	208/240 VAC	30 amp	1 Ph

* NSF certification applies to the Tornado, C3, and HhB 2 ovens only. UL EPH certification applies to all ovens except the C3.

Menu Requirements

TurboChef ovens have been approved by Underwriter’s Laboratory for ventless operation (UL KNLZ listing) for all food items EXCEPT for foods classified as “fatty raw proteins.” Such foods include bone-in, skin-on chicken, raw hamburger meat, raw bacon, raw sausage, steaks, etc.

The TurboChef certification includes precooked food items such as pizza toppings, sandwich meats, frozen appetizers, and cheeses. Additionally, raw, lean meats such as boneless, skinless chicken breasts and fish fall within the certification.

Cleaning Requirements

To ensure continued compliance with all health, building, and fire codes, users are required to:

- Use only TurboChef-approved cleaning chemicals.
- Follow monthly and quarterly cleaning instructions provided in the manual. Post cleaning instructions near the oven.
- Ventless installation requires that the areas around the oven (walls, ceilings, kitchen equipment, etc.) be cleaned as needed but no less than once every other month.

Installation Near Open Heat Source

When placing a TurboChef oven near an open heat source (see illustration below), strictly adhere to the following:

- If the oven is being placed near a grill or stove, a divider must exist between the oven and the open heat source, with a minimum of 6” (152 mm) between the oven and the divider.
- If the oven is being placed near a fryer, a divider must exist between the oven and fryer, with a minimum of 12” (305 mm) between the oven and the divider.
- The height of the divider must be greater than or equal to the height of the oven.

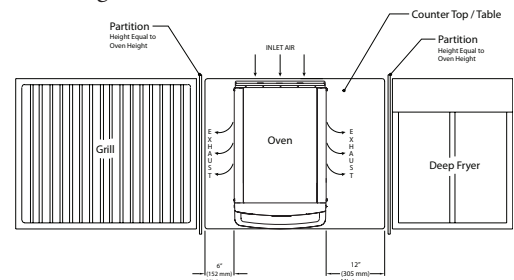

Oven Clearances

Verify the oven location has the following clearances on the top and each side. TurboChef ovens have built-in back bumpers that allow for the necessary spacing from the oven to the back wall.

Oven	Top	Sides
Sóta / Sóta Single Mag (i1)	5" (127 mm)	2" (51 mm)
i3	19" (483 mm)	2" (51 mm)
i5	19" (483 mm)	2" (51 mm)
Encore/Encore 2	5" (127 mm)	2" (51 mm)
Tornado	4" (102 mm)	2" (51 mm)
C3	4" (102 mm)	2" (51 mm)
HhC 2620	10" (254 mm)	0" (0 mm)
HhC 2020	10" (254 mm)	0" (0 mm)
HhC 1618	10" (254 mm)	0" (0 mm)
HhB 2	2" (51 mm)	2" (51 mm)
Double Batch	2" (51 mm)	2" (51 mm)
Waterless Steamer (i1)	5" (127 mm)	2" (51 mm)
Panini (i1)	5" (127 mm)	2" (51 mm)
Fire	2" (51 mm)	2" (51 mm)
Bullet	5" (127 mm)	2" (51 mm)

Ventilation

TurboChef ovens must be installed in a well-ventilated space. The space should have an exhaust rate of .70 cfm per square foot of kitchen space and an additional 100 sq. ft. (9.3 m²) of virtual space per ventless cooking appliance (TurboChef or any other).

If the air inlet is for general exhaust, pursuant to requirements for 507.2.2, paragraph 2, locate the air inlet above the center point of each oven.

The heat load from TurboChef ovens is mostly sensible. The only latent heat present is due to evaporation during the cooking process. When installing a TurboChef oven, the space must have the following tons of AC per oven installed.

Oven	Tons of AC
Sóta (i1)	0.29
Sóta Single Mag (i1)	0.29
i3	0.94
i5	1.31
Encore/Encore 2	0.45
Tornado	0.58
C3	0.63
HhC 2620	1.82
HhC 2020	1.47
HhC 1618	1.00
HhB 2	0.84
Double Batch	1.04
Waterless Steamer (i1)	0.29
Panini (i1)	0.29
Fire	0.50
Bullet	0.13

How the Ovens are Tested

TurboChef ovens are evaluated according to UL. The evaluation entails placing the test oven in an environmental chamber built to capture all emissions escaping during idle, cooking, and door-open conditions. During the eight-hour test period, a typical worst-case food item is cooked continuously, and 100% of condensable and non-condensable emissions from the product are collected and analyzed according to the EPA 202 Test Method. At the conclusion of the test, the total concentration of particulate matter (emissions) must be less than 5.0 mg/m³ for the oven to be certified for ventless operation. Cooking devices that measure above the 5.0 mg/m³ threshold are considered to produce grease and must be installed under Type I ventilation, according to International Mechanical Code.

TurboChef ovens are well below the 5.0 mg/m³ threshold as shown below.

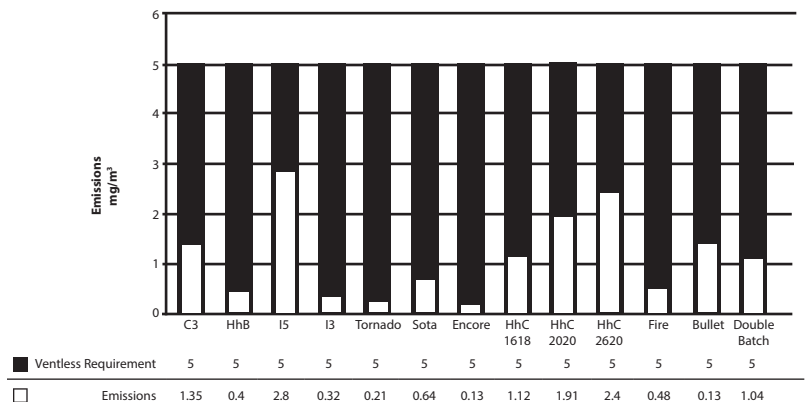

NOTE: Certain configurations of TurboChef ovens, such as a triple stacked HhC 2620, may cause emissions to be greater than 5.0 mg/m³. In these situations, TurboChef recommends that the ovens be installed under a Type I or Type II hood.

Contact Information

For questions regarding a ventless installation, email ventless.help@turbochef.com. For questions or concerns regarding an existing installation, contact Customer Service at 1.800.908.8726, Option 1.