



It's all about
connections

Manual 4400 Tier 3

400 Hz Generator Set Ground Power Unit



Specification.: ACE4400 60 – 100 kVA

Type: OM2245

AXA Power, Hobart, Houchin, Military and J&B has become ITW GSE.
As simply ITW GSE, we still offer the same premium products and service.
SAME PEOPLE - SAME PRODUCTS - SAME COMPANY

Operation Manual - ITW GSE 4400 Tier 3

IMPORTANT NOTICE

We recommend that the battery that safeguards GPU settings etc. is changed **after 5 years** of use in order not to lose data.

Diagrams and drawings are subject to change without prior notice.
Latest diagram versions can be found at www.itwgse.com

Operation Manual – ITW GSE 4400 Tier 3

Introduction

This manual contains operation and maintenance information for a diesel engine-generator manufactured by ITW GSE, Palmetto, Florida 34221

This manual, including all information contained therein, is exclusive and confidential property of ITW GSE. This manual is not to be copied, reproduced, or delivered or disclosed to others, in whole or in part, except with express written permission of ITW GSE.

This manual is not intended to be a textbook on electricity or electronics. Its primary purpose is to provide information and instructions to experienced operators, electricians, and mechanics that have never operated this equipment. It is the intent of this manual to guide and assist operators and maintenance personnel in the proper use and care of the equipment.

Use of the manual should not be put off until trouble or a need for help develops. Read the instructions before starting the unit. Learn to use the manual and to locate information contained in it. Its style and arrangement are very similar to commercial aircraft manuals.

The manual is divided into three chapters plus appendices. Each chapter is divided into as many sections as required. Each page is identified by chapter, section and page number, which are located in the lower, outside corner.

When information located in another portion of the manual is referred to, a chapter, section, and paragraph or figure number identify its location. For example: “(see Section 2-3, Paragraph 1.a.)” refers to information located in Chapter 2, Section 3, Paragraph 1.a. If a chapter and section are not indicated in a reference, the referenced material is located in the same section as the reference, for example: “(see Paragraph 1.a.)”

Contents of the manual are arranged as follows:

Chapter 1 Description/Operation

Chapter 2 Servicing/Troubleshooting

Chapter 3 Manufacturer’s Literature

Appendix A Active Rectifier Unit (ARU)

Appendix B Options

Appendix C Operation in Unusual Service Conditions

Appendix D Software Installation Procedures

Appendix E Schematics

Operation Manual – ITW GSE 4400 Tier 3

Safety Warnings and Cautions.

WARNING

ELECTRIC SHOCK can **KILL**. Do not touch live electrical parts.

ELECTRIC ARC FLASH can injure eyes, burn skin, cause equipment damage, and ignite combustible material. **DO NOT** use power cables to break load. Prevent tools from causing short circuits.

IMPROPER PHASE CONNECTION, PARALLELING, OR USE can damage this and attached equipment.

IMPORTANT

Protect all operating personnel. Read, understand, and follow all instructions in the Operating/Instruction Manual before installing, operating, or servicing the equipment. Keep the manual available for future use by all operators.

WARNING

CALIFORNIA PROPOSITION 65 - DIESEL ENGINES. Diesel engine exhaust and some of its constituents are known to cause cancer, birth defects and other illnesses.

1) General

Equipment that supplies electrical power can cause serious injury or death, damage to other equipment or property. The operator must strictly observe all safety rules and take precautionary actions. Safe practices have been developed from past experience in the use of power source equipment. While certain practices below apply only to electrically powered equipment, other practices apply to engine-driven equipment, and some practices to both.

2) Shock Prevention

Bare conductors, terminals in the output circuit, or ungrounded, electrically live equipment can fatally shock a person. Have a certified electrician verify that the equipment is adequately grounded and learn what terminals and parts are electrically **HOT**. Avoid hot spots on machine. Use proper safety clothing, procedures and test equipment.

The electrical resistance of the body is decreased when wet, permitting dangerous currents to flow through it. When inspecting or servicing the equipment, do not work in damp areas. Stand on a dry rubber mat or dry wood, and use insulating gloves when dampness or sweat cannot be avoided. Keep clothing dry, and never work alone.

a) Output Cables and Terminals

Inspect cables frequently for damage to the insulation and the connectors. Replace or repair cracked or worn cables immediately. Do not overload cables. Do not touch output terminal while equipment is energized.

Operation Manual – ITW GSE 4400 Tier 3

3) Service and Maintenance

This equipment must be maintained in good electrical condition to avoid hazards stemming from disrepair. Report any equipment defect or safety hazard to the supervisor and discontinue use of the equipment until its safety has been assured. Repairs should be made by qualified personnel only. Before inspecting or servicing this equipment, take the following precautions:

- a) Shut off all power at the battery disconnect before inspecting or servicing the equipment.
- b) Lockout the equipment at the battery disconnect switch if it is out of service.
- c) If troubleshooting must be done with the unit energized, have another person present who is trained in turning off the equipment and providing or calling for first aid.

4) Fire and Explosion Prevention.

Fire and explosion are caused by electrical short circuits, combustible material near engine exhaust pipes, misuse of batteries and fuel, or unsafe operating or fueling conditions.

a) Electrical Short Circuits and Overloads.

Overloaded or shorted equipment can become hot enough to cause fires by self-destruction or by causing nearby combustibles to ignite.

b) Batteries.

Batteries may explode and/or give off flammable hydrogen gas. Acid and arcing from a ruptured battery can cause fires and additional failures. When servicing, do not smoke, cause sparking, or use open flame near the battery.

c) Engine Fuel.

Use only approved fuel container or fueling system. Fires and explosions can occur if the fuel tank is not grounded prior to or during fuel transfer. Shut unit **DOWN** before opening fuel tank cap. **DO NOT** completely fill tank, because heat from the equipment may cause fuel expansion overflow. Remove all spilled fuel **IMMEDIATELY**, including any that penetrates the unit. After clean-up, open equipment doors and blow fumes away with compressed air.

5) Toxic Fume Prevention.

Carbon monoxide - Engine exhaust fumes can kill and cause health problems. Pipe or vent the exhaust fumes to a suitable exhaust duct or outdoors. Never locate engine exhausts near intake ducts of air conditioners.

6) Bodily Injury Prevention.

Serious injury can result from contact with fans or hot spots inside some equipment. Shut **DOWN** such equipment for inspection and routine maintenance. When equipment is in operation, use extreme care in doing necessary troubleshooting and adjustment. Do not remove guards while equipment is operating.

Operation Manual – ITW GSE 4400 Tier 3

7) Medical and First Aid Treatment.

First aid facilities and a qualified first aid person should be available for each shift for immediate treatment of all injury victims. Electric shock victims should be checked by a physician and taken to a hospital immediately if any abnormal signs are observed.

EMERGENCY FIRST AID

SEEK ADDITIONAL ASSISTANCE. Use First Aid techniques recommended by American Red Cross until medical help arrives.

IF BREATHING IS DIFFICULT, give oxygen, if available, and have victim lie down.

FOR ELECTRICAL SHOCK, turn off power. Remove victim; if not breathing, begin artificial respiration, preferably mouth-to-mouth. If no detectable pulse, begin external heart massage.

8) Equipment Precautionary Labels

Inspect all precautionary labels on the equipment monthly. Order and replace all labels that cannot be easily read.

Operation Manual – ITW GSE 4400 Tier 3

Table of Contents

Chapter 1	Description/Operation	Chapter-Section/Page#
Section 1	Description	1-1/10
	1) General	1-1/10
	2) Optional Equipment - Appendix A and B	1-1/10
	3) Component Locations	1-1/11
	Figure 1-1-1: General Assembly of Generator Set	1-1/11
	Figure 1-1-2: Main Components of Generator Set (Right Side)	1-1/12
	Figure 1-1-3: Main Components of Generator Set (Left Side)	1-1/13
	Figure 1-1-4: Main Components of Generator Set (Bottom)	1-1/14
	4) Specifications	1-1/15
	5) Special Features	1-1/17
	6) Canopy	1-1/18
	7) Engine and Generator	1-1/18
	8) Power Module Assembly	1-1/20
	9) Operator Controls	1-1/22
	10) Cold Weather Starting System	1-1/26
Section 2	1) Preparation for Shipment	1-2/27
	2) Preparation for Storage	1-2/30
	3) Preparation for Shipment	1-2/31
Section 3	1) General	1-3/32
	2) 400 Hz. Operating Procedure	1-3-32
	3) Active Rectifier Unit (ARU)	1-3/36
	4) Icon Menu	1-3/37
	a) View Parameters Menu	1-3/38
	b) Setup Menu	1-3/39
	c) Black Box	1-3/50
	d) Power Log	1-3/51
	e) Update/Save Log Menu	1-3/52

Operation Manual – ITW GSE 4400 Tier 3

Chapter 2 Servicing / Troubleshooting Chapter-Section/Page#

	Maintenance Inspection/Check	2-1/55
	1) General	2-1/55
	2) Maintenance Schedule	2-1/55
	Figure 2-1-1 Maintenance Schedule Check Sheet	2-1/56
	3) Inspection / Checks	2-1/58
	a) General	2-1/58
	b) “AR” Checks and Operations (As Required)	2-1/58
	c) “BR” Checks and Operations (Break-In Period)	2-1/58
	d) “A” Checks and Operations (10 Hours or Daily)	2-1/59
	e) “B” Checks and Operations (250 Hours or 3	2-1/61
	f) “C” Checks and Operations (500 Hours or 6	2-1/62
	g) “D” Checks and Operations (1000 Hours or 1 Year)	2-1/63
	h) “E” Checks and Operations (1500 Hours or 1.5	2-1/64
	i) “F” Checks and Operations (2000 Hours or 2	2-1/65
	j) Seasonal Maintenance Checks Spring/Fall	2-1/66
	k) Lamps and Fuses	2-1/66
	Figure 2-1-4 Fuse Identification Chart	2-1/66
Section 2	Maintenance Procedures	2-2/67
	1) General	2-2/67
	Figure 2-2-1 Lubrication and Maintenance Chart	2-2/67
	2) Lubrication	2-2/68
	a) General	2-2/68
	b) Lubrication Schedule	2-2/68
	c) Oil Specification	2-2/68
	Figure 2-2-2 Lubrication Specifications	2-2/68
	d) Changing Engine Oil	2-2/69
	Figure 2-2-3 Oil Fill and Check Locations	2-2/69
	e) Engine Accessories Lubrication	2-2/71
	f) Trailer Lubrication	2-2/71
	3) Servicing the Air Cleaner	2-2/72
	a) Inspecting the Air Cleaner	2-2/72
	Figure 2-2-4 Air Cleaner Assembly	2-2/72
	b) Changing the Air Filter	2-2/72
	c) Disposal	2-2/72
	4) Engine Fuel	2-2/73
	a) How to Select Fuel - Quality	2-2/73
	b) Cold Weather Operation	2-2/73

Operation Manual – ITW GSE 4400 Tier 3

Chapter 2 Servicing / Troubleshooting Chapter-Section/Page#

5) Engine Fuel System	2-2/74	
a) Fuel Tank	2-2/74	
b) Fuel Water Separator or Lubricity Additive Filter	2-2/74	
Figure 2-2-5 Lubricity Filter	2-2/74	
c) Primary Fuel Filter	2-2/75	
Figure 2-2-6 Primary Fuel Filter	2-2/75	
d) Fuel Pump	2-2/76	
e) Fuel Return	2-2/76	
f) Fuel Level Indicators	2-2/76	
g) Draining the Fuel Tank	2-2/77	
6) Engine Cooling System	2-2/78	
a) General	2-2/78	
b) Radiator Cap	2-2/78	
c) Coolant	2-2/78	
d) Draining the Cooling System	2-2/79	
e) Flushing the Cooling System	2-2/79	
f) Cleaning the Radiator Core	2-2/80	
g) Filling the Cooling System	2-2/80	
h) Thermostat	2-2/80	
7) Engine Drive Belt	2-2/81	
8) Generator Maintenance	2-2/81	
9) Replacing the Control Board Battery	2-2/81	
Section 3	Adjustments / Tests	2-3/84
1) General		2-3/84
2) Testing the 400 Hz. Generator Set		2-3/84
a) Pre-operational Test Procedures		2-3/84
b) Engine Test Procedures		2-3/84
c) 400Hz Initial Testing and Setup		2-3/85
d) Output 1 Verification		2-3/85
e) Output 2 Verification		2-3/85
f) Sensor Testing		2-3/85
g) Re-checking the entire unit after testing		2-3/86
3) Generator Set Adjustment		2-3/86
4) Generator and Exciter Test		2-3/87
Figure 2-3-1 Generator and Exciter Test Readings		2-3/87
Figure 2-3-2 Generator Connections		2-3/88
5) Diode Test		2-3/88
6) Testing the Active Rectifier Unit (ARU) units w/DC Option		2-3/88

Operation Manual – ITW GSE 4400 Tier 3

Chapter 2	Servicing / Troubleshooting	Chapter-Section/Page#
------------------	------------------------------------	------------------------------

Section 4	Troubleshooting Procedures	2-4/90
	1) General	2-4/90
	2) Equipment for Troubleshooting	2-4/90
	3) Parts Replacement	2-4/90
	4) Normal Operational Parameters	2-4/90
	5) Check Connections and Leads	2-4/91
	6) Engine Troubleshooting	2-4/91
	7) GPU Control Monitoring	2-4/91
	8) Cummins Engine Fault Codes & Troubleshooting	2-4/92
	9) Troubleshooting Charts/Error Codes	2-4/92
	...Engine Controls	2-4/97
	...Generator Excitation Circuits	2-4/100
	...Generator	2-4/101
	...Load Contactor Operating Circuits	2-4/102
	...Protective Circuit	2-4/103

Chapter 3	Manufacturer's Literature	Chapter-Section/Page#
------------------	----------------------------------	------------------------------

Vendor Literature		3-1/104
	Appendix A – Active Rectifier Unit (ARU)	3-A/106
	Appendix B – Options	3-B/115
	Appendix C – Operating in Unusual Service Conditions	3-C/117
	Appendix D – Initial Software Installation Procedure	3-D/118

Operation Manual - ITW GSE 4400 Tier 3

Chapter 1 Description/Operation

Section 1 Description

1) General

The basic generator sets covered in this manual, manufactured by ITW GSE, are rated at 60kVA, 90kVA and 100kVA and are designed to produce and deliver 115/200-volt, 400 Hz, 3-phase AC power to a parked aircraft or other load. Some generator models with the Active Rectified Unit (ARU) option also provide 28.5 volts DC for aircraft having those requirements. A comprehensive review of the 28VDC output Active Rectifier Unit (ARU) is located in Appendix A.

Model Number	kVA	Mounting	Engine Certification	Outputs	28.5 DC Output
ACE44xxSTT3-US	xx	Trailer	Tier 3 US Labeled	Single 400Hz	No
ACE44xxSTT3-EX	xx	Trailer	Stage 3a EX Labeled	Single 400Hz	No
ACE44xxS28TT3-US	xx	Trailer	Tier 3 US Labeled	Single 400Hz	Yes
ACE44xxS28TT3-EX	xx	Trailer	Stage 3a EX Labeled	Single 400Hz	Yes
ACE44xxDTT3-US	xx	Trailer	Tier 3 US Labeled	Dual 400Hz	No
ACE44xxDTT3-EX	xx	Trailer	Stage 3a EX Labeled	Dual 400Hz	No
ACE44xxD28TT3-US	xx	Trailer	Tier 3 US Labeled	Dual 400Hz	Yes
ACE44xxD28TT3-EX	xx	Trailer	Stage 3a EX Labeled	Dual 400Hz	Yes

xx – 60, 90, 100 (i.e. ACE4460T3-US is rated for 60 kVA full load output)

Table 1-1-1: ITW GSE 4400 Series Generator Set Part Number Descriptions

2) Optional Equipment - Appendix A and B

Chapters 1 through 3 of this Operation and Maintenance Manual identify only the basic version of the ITW GSE 4400 generator set. Appendix A describes the Active Rectifier Unit (28.5 VDC) option. Appendix B contains a list of the rest of the optional equipment that can be ordered with the unit. Each item has a brief description of the optional equipment.

Operation Manual - ITW GSE 4400 Tier 3

3) Component Locations

For purpose of orientation when designating RIGHT and LEFT throughout this manual, the radiator is considered to be at the FRONT of the unit and the generator is at the REAR. RIGHT and LEFT are determined by standing at the REAR facing the machine. As an example, the control panel is mounted on the RIGHT FRONT side of the unit.

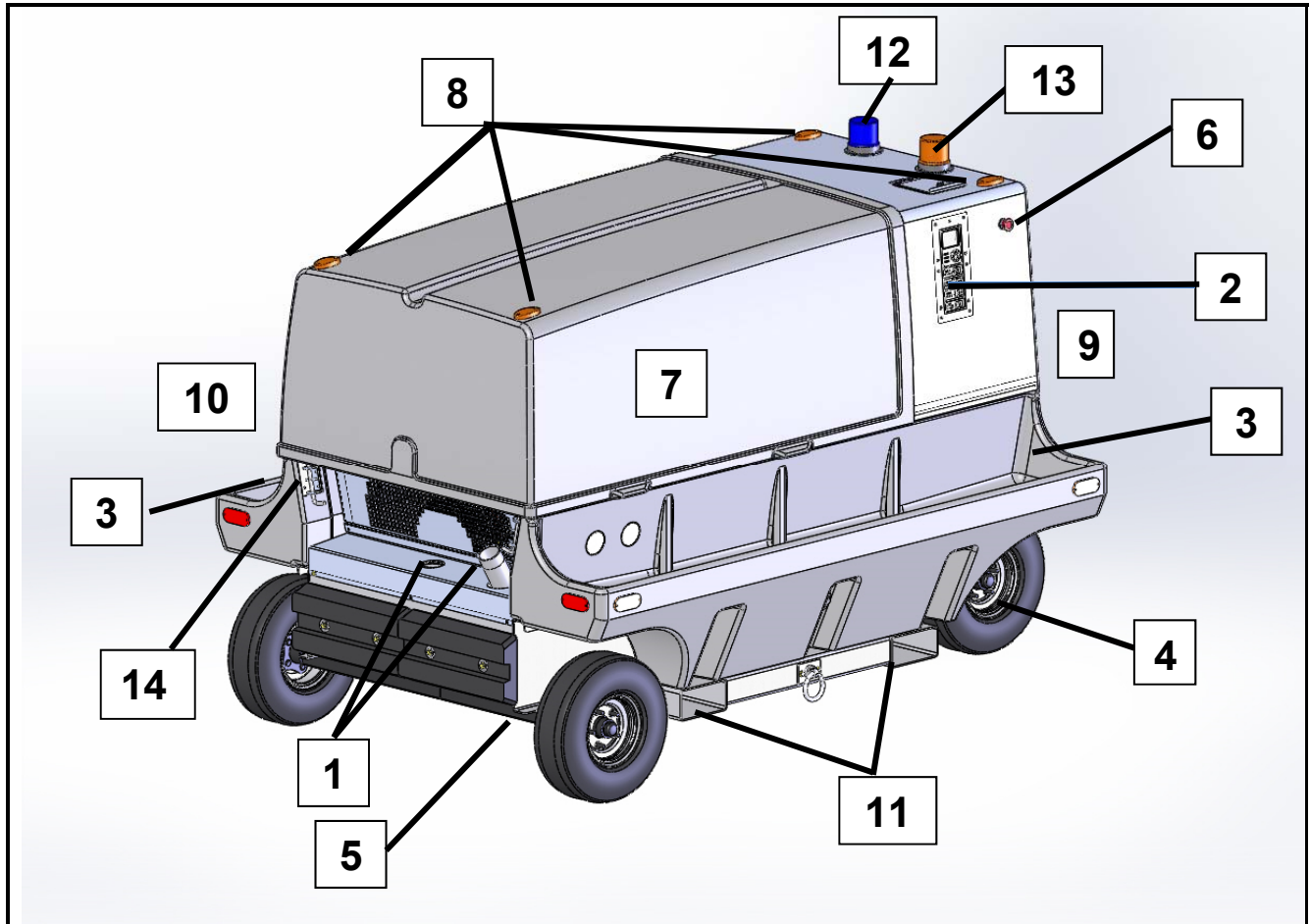

- | | |
|------------------------------------|-------------------------------|
| 1. Fuel Filler Neck / Manual Gauge | 8. Clearance Lights (Option) |
| 2. Operator Control Panel | 9. Radiator End |
| 3. Composite Output Cable Trays | 10. Generator End |
| 4. Fifth Wheel Assembly | 11. Forklift Pockets |
| 5. Rear Axle Assembly | 12. Low Fuel Beacon (Option) |
| 6. Emergency Stop Switch | 13. Operating Beacon (Option) |
| 7. Sliding/Removable Canopy | 14. Canopy Locking Latch |

Figure 1-1-1: General Assembly of Generator Set

Operation Manual - ITW GSE 4400 Tier 3

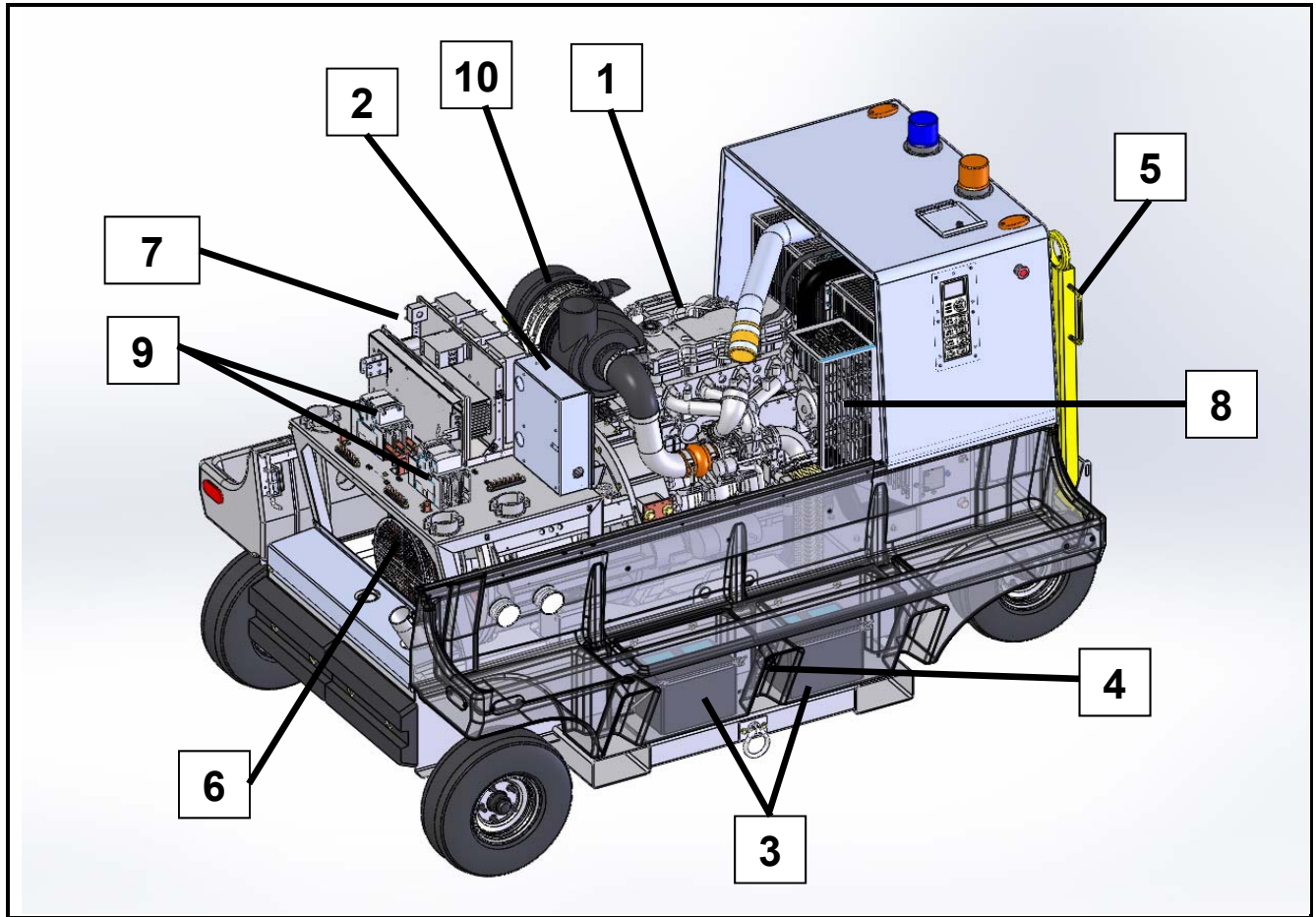

- | | |
|------------------------------------|--------------------------|
| 1. Cummins QSB4.5 Engine | 6. Generator |
| 2. Control Module Assembly | 7. 28.5 VDC ARU (Option) |
| 3. Batteries (inside tray pockets) | 8. Engine Alternator |
| 4. Battery Disconnect | 9. Output Contactors |
| 5. Tow bar Assembly | 10. Air Filter Assembly |

Figure 1-1-2: Main Components of Generator Set (Right Side)

Operation Manual - ITW GSE 4400 Tier 3

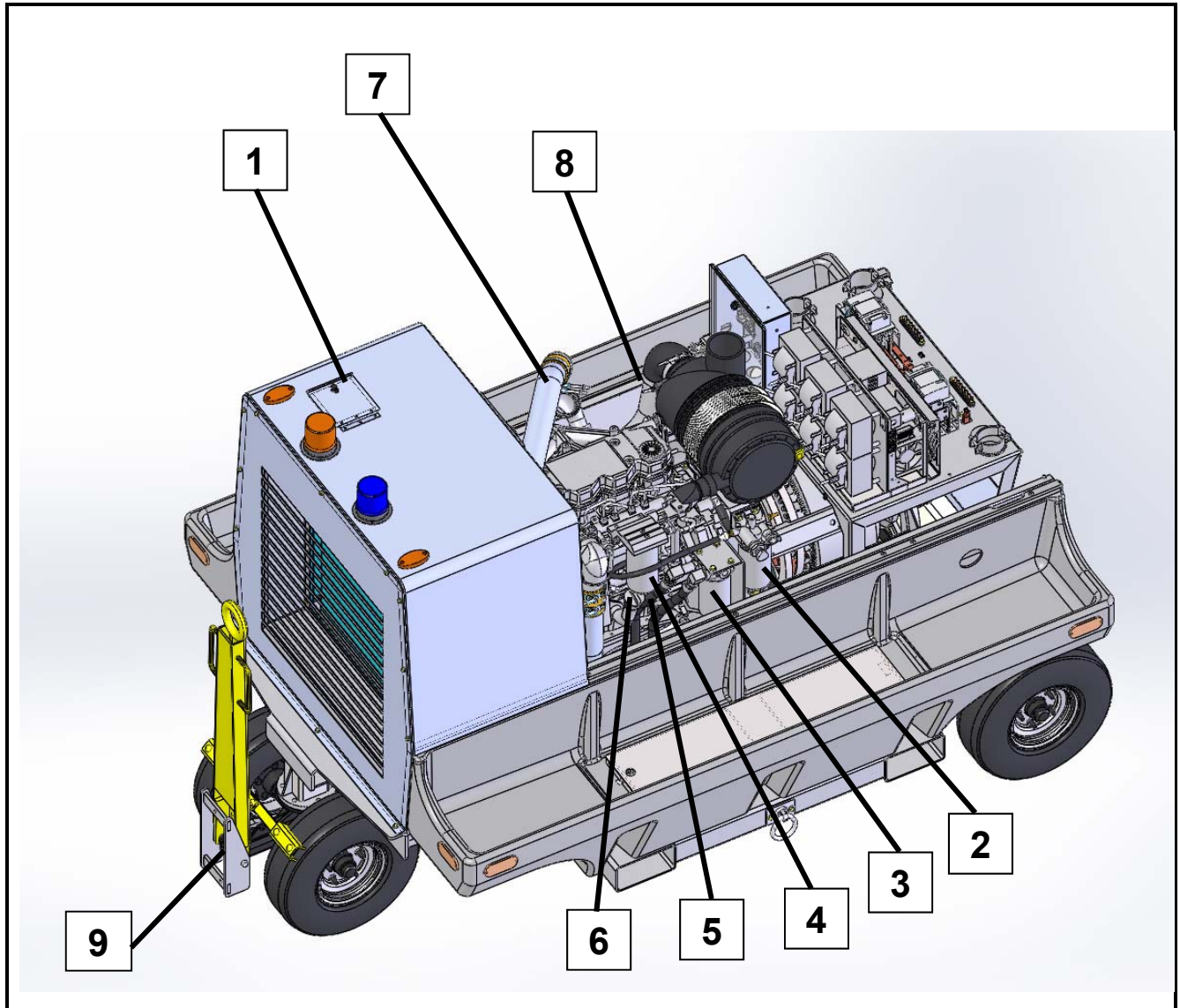

- | | |
|---------------------------------------|--------------------------------|
| 1. Coolant fill access cover | 6. Engine Oil Fill Tube |
| 2. Lubricity Additive Fuel Pre-Filter | 7. Charge-Air-Cooler Piping |
| 3. Engine Oil Filter | 8. Engine Air Intake Piping |
| 4. Fuel Filter | 9. Tow Bar/Brake Release Lever |
| 5. Engine Control Module (ECM) | |

Figure 1-1-3: Main Components of Generator Set (Left Side)

Operation Manual - ITW GSE 4400 Tier 3

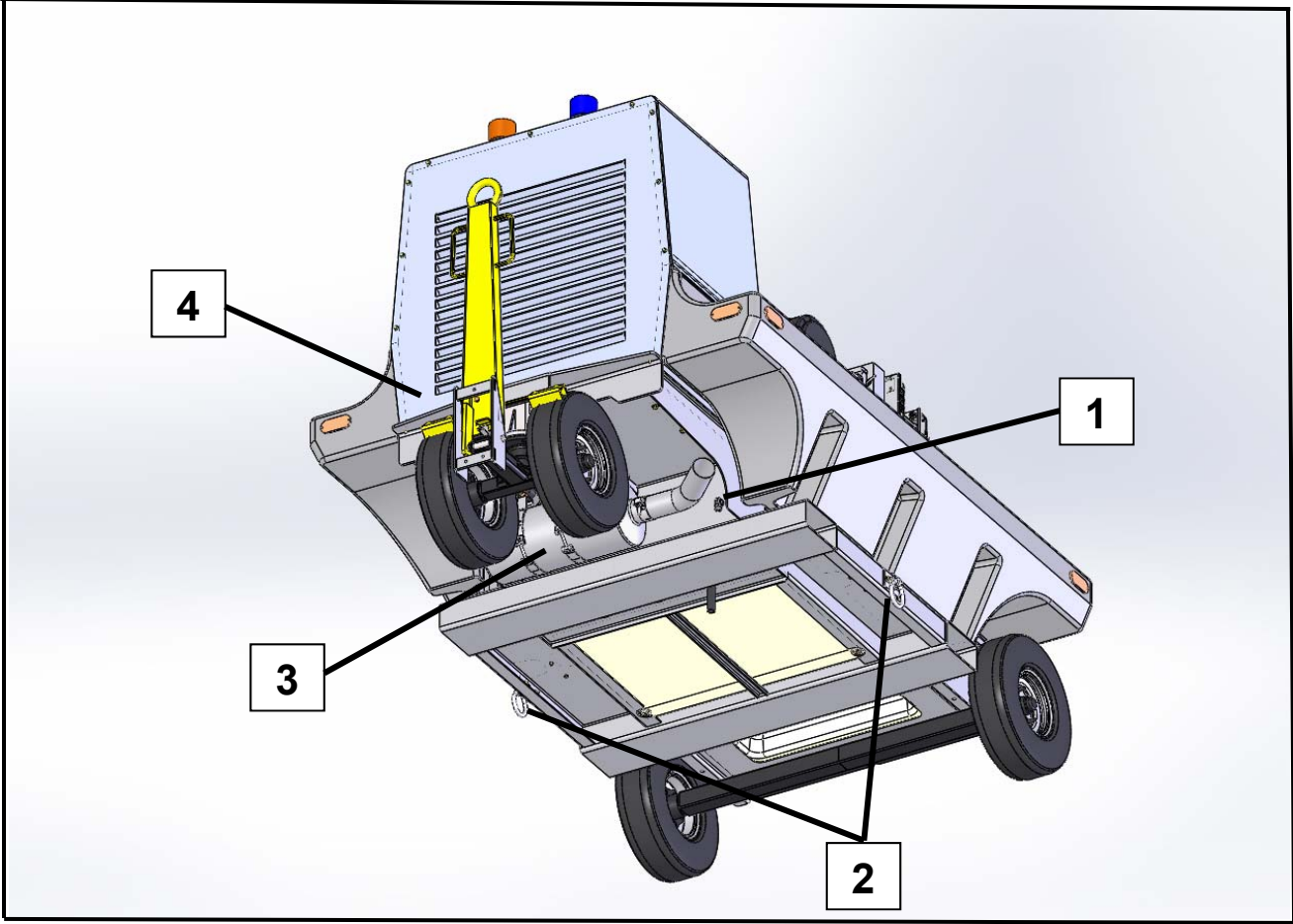

- 1. Oil Drain Valve
- 2. Tie Down Rings (Option)
- 3. Muffler Assembly
- 4. Radiator Drain Valve & Hose

Figure 1-1-4: Main Components of Generator Set (Bottom)

Operation Manual - ITW GSE 4400 Tier 3

4) Specifications

a) Standards

These units have been designed to be in compliance with the following standards:

US EPA Tier 3/CARB Tier 3
 EU Stage III A
 US MIL-STD-704F, SAE ARP5015
 ISO 6858
 CE compliance certified

b) Physical Specifications

Length	104 in. (2635 mm) w/ towbar up
Width	66.7 in. (1694 mm)
Height	63.9 in. (1622 mm)
Weight (dry)	4000 lb. (1814 kg.)
Weight with 28.5 VDC ARU	4300 lb. (1950 kg.)
Operating Temperatures	-25°F* to +125°F -32°C to +52°C
*Low temperature option - Battery Blanket & Block Heater	-40°F/C

c) AC Output Specifications

Output Power Rating	60 kVA (48 kW)	90 kVA (72 kW)	100 kVA (80 kW)
Output Voltage	115 / 200 VAC	115 / 200 VAC	115 / 200 VAC
Rated Load Capacity	173 Amps	260 Amps	290 Amps
Frequency	400 Hz.	400 Hz.	400 Hz.
Power Factor	0.8	0.8	0.8
Duty Cycle	100%	100%	100%
Operating Speed	2400 RPM	2400 RPM	2400 RPM
Overload Capacity 125% rated load	216 Amps	325 Amps	325 Amps
Output Cable Size	2/0 – if banded or JB8816-xxx	2/0 – if banded or JB8816-xxx	2/0 – if banded or JB8816-xxx
Insulation Class	H	H	H

Operation Manual - ITW GSE 4400 Tier 3

d) AC Protective System Specifications

Condition	Trip Point		Time Delay
Over Voltage	130 volts		250 milliseconds
	140 volts		15 milliseconds
Under Voltage	any voltage below 104 volts		500 milliseconds
Over Frequency	380 Hz to 420 Hz		1 second
	above 480 Hz		immediate
Under Frequency	380 Hz. or less		5 seconds
	60 kVA & 90 kVA	100 kVA	
Output Overload	80% load at PF 0.8 to 1.0	80% load at PF 0.8 to 1.0	Continuous
	100% load at PF 0.7 to 0.8	100% load at PF 0.7 to 0.8	Continuous
	100% to 125% load	100% to 112% load	10 minutes
	125% to 150% load	112% to 134% load	10 seconds
	150% to 175% load	134% to 157% load	2 seconds

e) DC Output Specifications (with optional TR unit)

Output Power Rating	17.1 kW
Output Voltage	28.5 VDC
Load Capacity (Continuous)	600 A
Current Limiting Capability	300 to 2000 A in selectable steps (50/100/200/300A)
Peak/Starting Load Capacity	2000 A for 5 seconds
Output Cable Size	4/0 for continuous loads up to 400A 2x 4/0 for continuous loads up to 600A

f) DC Protective System Specifications

Condition	Trip Point	Time Delay
Over Voltage	32 - 40 VDC	4 seconds
	Over 40 VDC	150 ms
Output Overload	2400 A	5 seconds
	1800 A	10 seconds
	1200 A	30 seconds
	800 A	30 seconds

Operation Manual - ITW GSE 4400 Tier 3

g) Engine Specifications

Manufacturer and Model	Cummins Engine Company / QSB4.5
Type	4 cylinder, 4 cycle diesel, electronic controlled
Bore and Stroke	4.21 in. x 4.88 in. (107 mm x 124 mm)
Displacement	275 in ³ (4.5 L)
Horsepower	171 hp (132 kW)
Idle Speed (Not authorized for EX units)	1000 ± 50 rpm
Normal Governed Speed	2000 rpm
Firing Order	1-3-4-2
Electrical System	24 VDC
Lubricating Oil Capacity (w/ filter)	11.6 quarts (11 liters)
Coolant Capacity System	20 quarts (18.9 liters)
Fuel Tank Capacity	53 gallons (200 liters)

h) Normal Operating Characteristics

Engine Oil Pressure (warm and at rated speed 2000 RPM)	45 to 90 PSI (445 to 621 kPa).
Engine Coolant Temperature (normal operation)	160 to 200° F (71 to 93° C).

5) Special Features

The generator set has special features that are described more fully under the assemblies in which they appear.

a) Protective Monitoring

The protective monitoring system receives signals from the fault sensing components in the generator output circuit and functions to cause the load to be disconnected from the generator if an abnormal condition of voltage, frequency, or load develops. The nature of that abnormal condition is then presented on the graphical display.

b) Voltage Regulator

A microprocessor-type, adjustable voltage regulator provides automatic voltage regulation at the aircraft. The regulated output is also adjustable for a variety of output cable sizes and lengths.

c) Engine Electronic Control Module (ECM)

The engine is equipped with an electronic control module (ECM) that monitors, records, and controls engine performance.

d) Battery System Disconnect Switch

The generator set is equipped with a battery disconnect switch outside the unit on the RIGHT side. The disconnect switch should be placed in the OFF position for long periods of shutdown.

NOTE: DO NOT disconnect the batteries when the engine is running or within two (2) minutes after the engine stops.

Operation Manual - ITW GSE 4400 Tier 3

6) Canopy

A composite enclosure, identified as a canopy, provides protection for the engine, generator and electrical controls. The canopy is also designed to reduce the operational noise level in the immediate area of the machine. The canopy is equipped with a bolted latch on the back left corner, which will require the use of a wrench to remove the canopy. Once the bolt is loosened the canopy can be slid to the rear and removed by two people for easy access to all engine and generator components.

We recommend using Simple Green® Industrial Cleaner & Degreaser or an equivalent to clean the canopy and cable trays.

7) Engine and Generator

The engine and generator comprise the principal components of the generator set. They are mounted on a galvanized, welded steel frame chassis. The following figures show the locations of all major components and sub-assemblies.

a) Diesel Engine

The diesel engine is a fuel injection, 4-cylinder, electronically controlled engine rated at 171 horsepower.

b) Engine Manufacturer's Components

As received from the engine manufacturer, the engine includes some of the following components, which are more fully described in the engine manufacturer's manual.

1) Electrical System

The 24 VDC electrical generating and starting system includes an alternator and starter with solenoid switch.

2) Lubricity Additive Fuel Filter

The fuel filter is a spin-on disposable type located on the inside of the canopy, near the engine's fuel pump. The fuel filter's primary function, other than removing contaminants from fuel, is to automatically add a lubricity additive to the fuel. Although, the engine manufacturer does not recommend low lubricity fuels, this additive can extend the life of the fuel pump.

CAUTION	The use of low lubricity fuels can shorten life and/or damage the engine's fuel pump. Only diesel fuel is recommended by the engine manufacturer. Refer to engine manufacturer's manual for approved fuels.
----------------	---

3) Oil Filter

The engine oil filter is a spin-on, full-flow type, located on the left side of the engine near the front.

4) Pre-programmed Electronic Control Module (ECM)

The ECM is a pre-programmed engine control module, mounted directly to the engine block.

Operation Manual - ITW GSE 4400 Tier 3

c) Factory Installed Components and Protective Systems

This generator set is assembled with the following components and protective systems:

1) Shutdown/Reset Systems

- Emergency Shutdown

The emergency shutdown switch is to provide instant manual shut off of the generator set by disconnecting power to the ECM through the control box. It is located on the FRONT RIGHT of the generator set next to the control box.

To operate the **EMERGENCY SHUTDOWN**

- Push button in until engine stops or until button travel stops
- Pull the button back out to reset

CAUTION

Do not use the "**EMERGENCY STOP BUTTON**" as a normal shutdown device. Damage to the engine turbo charger may result without proper cooling time. Use the Engine ON/OFF push-button for all normal engine shutdowns.

- Low Fuel Warning System

The low fuel warning system monitors the fuel level in the fuel tank. When the fuel tank level reaches approximately 10%, a warning is generated signifying it is time to put fuel in the tank. Once the engine is not running, a low fuel fault is generated and the engine is not allowed to start.

2) Radiator and Charge-Air-Cooler (CAC)

The radiator and charge-air-cooler is a two-piece type designed for long periods of operation without servicing.

3) Engine-Cooling Fan

The engine fan is designed to blow air outward through the radiator, rather than pulling air inward like a conventional fan.

4) Master [Battery] Disconnect Switch

The master disconnect switch is designed to isolate the batteries from the entire electrical system to eliminate the possibility of battery current draw by the engine ECM or any other components during long periods of no operation. The switch can also be used to lock-out the starting circuit of the equipment for maintenance safety purposes.

5) Air Cleaner

The diesel engine air cleaner is constructed so that air enters through its cylindrical body, and then is filtered before being passed into the engine turbo-charger assembly. An air cleaner service indicator device is mounted on the air cleaner assembly to monitor the airflow into the air cleaner. As the air cleaner becomes filled with dust, dirt, and carbon, the intake system airflow becomes increasingly restricted. This restriction causes a diaphragm inside the indicator to move toward an electrical contact. When the maximum allowable restriction level is reached, the circuit closes and the air cleaner indicator fault appears on the control panel fault display to warn the operator that the air cleaner must be changed. The electrical indicator automatically resets when the restriction level drops sufficiently. Note: This function should not be used as a replacement indicator. Follow recommended replacement schedule as specified in this manual.

Operation Manual - ITW GSE 4400 Tier 3

d) Warnings/Faults

The control system reacts appropriately to different detected issues. These types can be generalized between warnings and faults. Warnings are given when the system is able to function but requires servicing/user interaction. Faults are generated when the unit cannot or should not supply regulated power to the aircraft.

All faults prevent the engine from starting. However, they react differently to an operating unit. Faults can be categorized into three subcategories as defined by the fault number.

- Fault numbers less than 6000
 - Minor faults: Will disconnect power to the aircraft but not affect engine and generator functions.
- Fault numbers between 6000 and 8000
 - Mid-level faults: Will disconnect power to the aircraft, turn off the generator and shut down the engine after the required 30 second cool down.
- Fault numbers greater than 8000
 - Major faults: Result in immediate shutdown of all system components including the engine. Service is required on the unit before it is returned to operation.

Engine generated warnings and faults are also monitored and their respective Cummins fault numbers are shown on the display.

e) Generator

The 400 Hz generator is a brushless, dual bearing, revolving field, three-phase, alternating current type unit. The front end of the rotor shaft extends forward beyond the front bearing and is coupled to the engine flywheel by a flexible coupling assembly. The rear end of the rotor shaft extends rearward beyond the rear bearing and into the exciter stator housing. The exciter rotor is mounted on this shaft extension with a key and is secured by a washer and 1/2-13 threaded cap screw.

The rectifier has six diodes mounted on the exciter rotor and converts exciter AC output to DC for excitation of the generator revolving fields. The exciter outputs DC to the generator fields, and consequently the generator output is controlled by the voltage regulator PC board (REG). A centrifugal, radial-blade fan draws cooling air over all internal windings. Air enters at the exciter end and is discharged at the drive end. The complete generator assembly is bolted to the engine's flywheel and housing.

8) Power Module Assembly

The Power Module Assembly is mounted on the ARU table located to the rear of the machine over the generator. The panel assembly provides a means of connecting and disconnecting the generator output to and from the aircraft.

a) Load Contactor (K1 and K2)

Each load contactor contains a magnetic operating coil and four sets of contacts. The three larger contacts conduct three-phase AC generator output. A small contact set is connected to the Digital Control PC Board (CTL) to activate the protective monitor circuit. Three-phase, 400-Hz generator output power is distributed to the load contactor by 2/0 cables that pass through current transformers.

b) Current Transformers (CT1-CT3)

A set of current transformers are used to monitor and control the line-drop compensation, ammeter, and overload circuit.

1) Line-Drop Compensation

Operation Manual - ITW GSE 4400 Tier 3

The current transformers detect the magnitude and power factor of current flowing from generator to load. They feed a signal to the voltage regulator that interprets the signal and alters the exciter field current as required to maintain a constant predetermined voltage at the load. These values are accessible on the color display.

2) Ammeter

The current transformers convert a current signal to a voltage signal, which is sent to the interface board and read by the processor boards. This signal is digitized and sent to the display board where user can read on the color display in phase to phase or phase to N format.

3) Overload

The digitized signal is also processed to determine if the generator output is within defined specifications. If the current is within the following values, then output contactor(s) are opened at the prescribed time.

- Continuous 100% rated load at PF 0.7 - 0.8
- Continuous 80% rated load at PF 0.8 - 1.0
- 5 minutes 100% rated load at PF 0.8 - 1.0
- 10 seconds 120% rated load at PF 0.7 - 0.8
- 2 seconds 150% rated load at PF 0.7 - 0.8

Operation Manual - ITW GSE 4400 Tier 3

9) Operator Controls

The control box is a protected enclosure on the right front panel of the GPU with a modern graphical display and easy to understand controls. The display allows the user to easily have access to all critical operational information as well as providing textual descriptions of all warnings and failures.

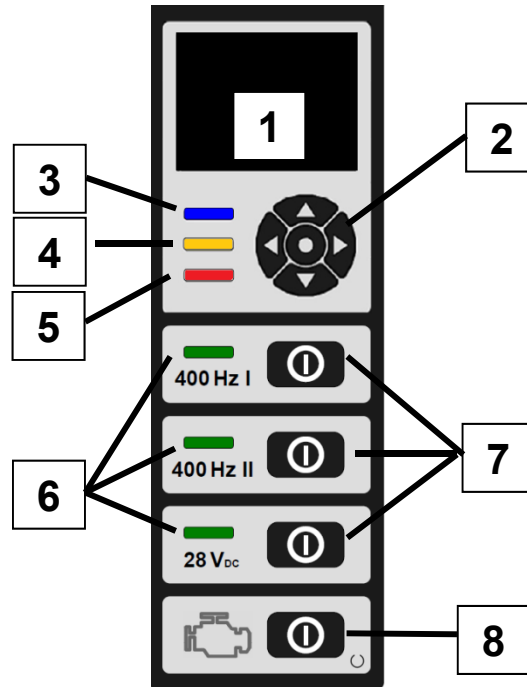

- | | |
|--------------------------|---|
| 1. LED Graphical Display | 5. Alert/Failure "Red" LED |
| 2. Navigation Keypad | 6. Output ON "Green" LEDs |
| 3. Power ON "Blue" LED | 7. Output ON/OFF (Reset) |
| 4. Warning "Amber" LED | 8. Power ON & Engine Start/Stop (Reset) |

Figure 1-1-5 Control Panel

1: The color LED Graphical Display and easy to use menu system places all required operational information at the fingertips of the operator/maintenance personnel. Its color presentation accents critical data and simplifies the troubleshooting process by giving textual descriptions of any potential issues.

2: The Navigation Keypad is used to navigate through the simple menu systems.

3: The Blue LED indicates that power is ON. (It is off in sleep mode)

4: The Amber LED indicates a warning. The details of that warning are available on the display. Up to five warnings can be displayed at one time.

5: The Red LED indicates a fault. The details of this fault are also visible on the graphics display. Only one fault can be displayed at one time.

6: The Green LED's indicate that the respective output is ON.

7: The ON/OFF buttons are used to turn on and off their respective outputs. If a specific output has a fault, the corresponding ON/OFF button will also reset that fault.

Operation Manual - ITW GSE 4400 Tier 3

8: The Power ON & Engine Start/Stop button will wake the unit from low-power sleep mode. Pressing it again will begin the start-up sequence for the diesel engine. Pressing it again will shut down the engine. If the engine is already running, it will begin the manufacturer required 5 minute cool down. If the unit has a fault, this button will reset the fault.

NOTE! – The screens shown in this manual reflect the current software version at the time of publication. The screens on your unit might differ slightly based on the software version running on your unit. Any changes will be described in a Service Bulletin which should be placed in the back of this manual.

Default Screen:

There are two default displays depending on whether the engine is running or not. When the unit finishes its self-check after first being powered up, the display will show the number of hours the engine has been operating. After a short delay, the engine hours are replaced with the current time. This then becomes the default display when engine is off. (The engine operating hours are always available on the “Engine” information screen.)

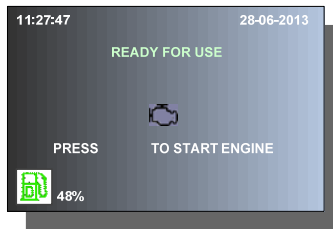

During the engine start process, the screen will be modified to show the current status until the engine is running and the unit is ready to output power.

Note: If the engine is configured to go to idle until an output is activated, it will still say it is ready for use. However, the engine will have to ramp up to 2000 RPM and the voltage stabilized before the output contactor will close.

When output power is ready, the screen will appear as follows showing all available outputs:

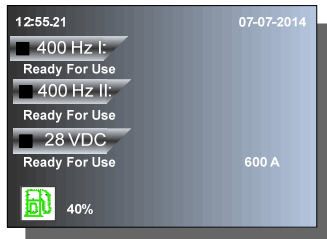

Both default screens enable the user to quickly have access to other pertinent information by pressing ▼ or ▲ to cycle through the display screens below:

Operation Manual - ITW GSE 4400 Tier 3

The 28V data page will only be displayed if that option is available.

Pressing ◀ will return to the default menu screen.

Unit information is displayed using the Parameter Information icon. To access the information icon, press the ● from the default menu and hold it down for approximately 5 seconds.

To select a submenu, simply use the navigation keys ◀▼▲▶ to highlight the icon and then press the ● to enter the sub-menu.

To leave the Icon Menu highlight the "Home" icon and press ●

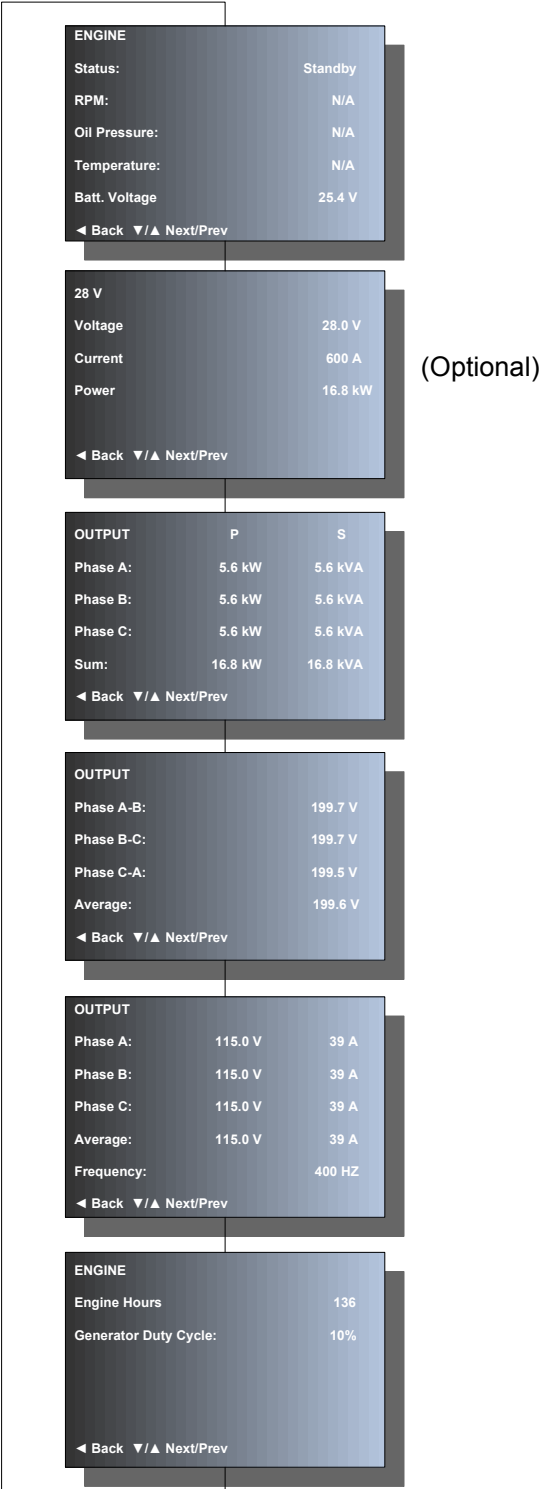

Operation Manual - ITW GSE 4400 Tier 3

Parameters – Menu structure



Highlight the **i** by using the navigation **◀▶▲▼** keys.

Press **●** to select "View parameters" sub-menu.

Use the the **▼/▲** to browse through the various screens.

Use **◀** to leave the sub-menu and return to basic Icon Menu.

Notice!

Parameters may vary depending on the mode of the unit Standby / operating / load profile etc.

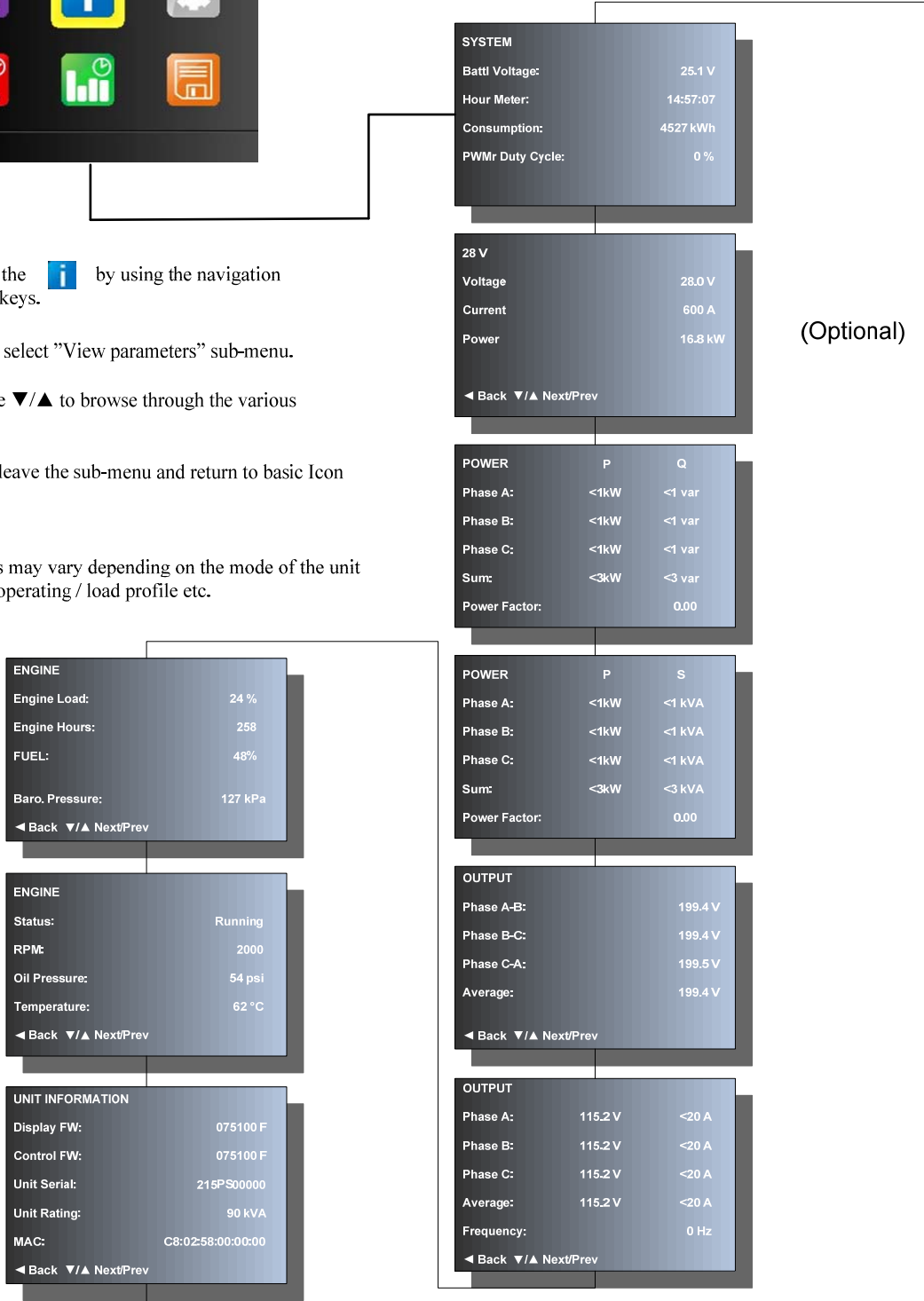

Operation Manual - ITW GSE 4400 Tier 3

10) Cold Weather Starting System (BH1)

The intake air heater, located on the intake manifold, is used for starting the engine at very cold temperatures and reduces the white smoke associated with a cold start. The intake air heater (or grid heater) is energized or de-energized from a power relay controlled by the ECM. The amount of time the air intake heater stays on, in the preheat phase, is a function of the intake manifold temperature at start up. (The pre-heat time increases with colder intake manifold temperatures). The maximum duration of the pre-heat phase is around 30 seconds.

CAUTION

Never use an ether start system in conjunction with the air intake heater.



Figure 1-1-6: Air Intake Heater

11) Active Rectifier Unit (ARU)

- See Appendix A

Operation Manual ITW GSE 4400 Tier 3

Section 2 Preparation for Use, Storage, or Shipping

1) Preparation for use after receipt of unit

a) Inspection/Check

Inspect unit thoroughly prior to operation.

- 1) Remove blocking, banding, ties, and other securing material.
- 2) If Tie Down Rings are present, make sure they are secured with both bolts. (Typically one bolt is used to secure middle blocks to unit during shipping.)
- 3) Inspect exterior for shipping damage such as broken lights, damaged sheet metal, etc.
- 4) Slide the canopy open and inspect the interior for foreign material such as rags, tools, shipping papers, etc.
- 5) Check fuel, coolant, oil hoses and connections for visible leaks. Visually inspect compartment floor and ground surface under unit for signs of leakage. Correct any leaks by tightening hose clamps, tube fitting, etc., as required.
- 6) Check tightness of generator set retaining components.
- 7) Check fuel level. (A manual quick reference fuel gauge is located at back of unit. This gauge is accurate only when fuel level is above 50%.)

NOTE: For recommended fuel specifications, refer to Engine Manufacturers Operation and Maintenance Manual provided with this manual.

- 8) Check engine coolant. Remove radiator cap (under hatch on top of operator section) to check coolant level. Coolant level should be at bottom of filler neck.

CAUTION	Be sure cooling system antifreeze solution is adequate to protect below lowest temperature expected.
----------------	--

NOTE: For antifreeze protection, use a solution of 50% permanent antifreeze (Ethylene glycol) and 50% clean water.

Lubricating oil capacity (w/ filter)	2.9 gallons (11 liters)
Coolant capacity system	5 gallons (18.9 liters)

Figure 1-2-1: Engine Oil and Coolant Capacities

Operation Manual ITW GSE 4400 Tier 3

- 9) Check engine lubricating oil level. The oil gauge rod has “H” high-level and “L” low-level marks to indicate operating lubrication oil supply. Oil level should be kept as near the high mark as possible, without going over. See Figure 1-2-1 for capacity.

CAUTION

NEVER operate engine with oil level below “L” level or above “H” level mark.

NOTE: See Engine Manufacturer's Operation Maintenance Manual for oil recommendations.



Figure 1-2-2: Oil Fill and Oil Level Check Locations

- 10) Check batteries located inside the right-side cable tray. Inspect batteries for proper connection of terminals. Service or replace if necessary.

Operation Manual ITW GSE 4400 Tier 3

b) Installing Three-Phase AC Output Cables



Figure 1-2-3



Figure 1-2-4



Figure 1-2-5

The generator set may be shipped without aircraft cables. Output cables connect to the load contactors, which are located at rear of unit. (See Figure 1-2-3)

The conductor size recommended for AC output cables is 2/0 AWG. Use No. 12 AWG for E and F terminals. Lugs require a minimum 3/8-inch diameter hole to fit into the output contactor. (See Figure 1-2-4) The E and F wires should be fitted with 16 gauge forks or into a double ferrule and then inserted into the normally open auxiliary contact block attached to the side of the output contactor. (See Figure 1-2-5)

AC output cables installation:

- 1) Remove canopy. (While not necessary, it greatly simplifies the process.)
- 2) Loosen screws on cable clamps.
- 3) Route cables through hole in cable tray, through cable clamps up to load side of load contactor(s).
- 4) Connect phase cable terminal lugs to appropriate terminal studs on contactor(s): cable lug A to terminal stud A, B to B, and C to C.
- 5) Connect cable's neutral terminal lug securely to neutral (ground) stud on power module assembly. (See Figure 1-2-4)
- 6) Connect E and F cables into the auxiliary contact block on side of output contactor.
- 7) Tighten clamp screws securely, but avoid damage to cable insulation.
- 8) Replace canopy.

Operation Manual ITW GSE 4400 Tier 3

c) Installing DC Output Cable (optional)

- 1) Remove canopy. (While not necessary, it greatly simplifies the process.)
- 2) For normal aircraft service, use cable assembly JB2840-30 (which meets Mil-C-7974D Assembly Specification) with 30 feet of AWG 4/0 cables having a positive and negative connection.
- 3) Cable extends through frame via supplied hole in cable tray. (See Figure 1-2-3)
- 4) Cables connect to output bus bar located on ARU assembly located left rear of unit. (See Figure 1-2-6)
- 5) Replace canopy.



Figure 1-2-6

d) Tow Bar Interlock (optional)

- 1) The Tow Bar Interlock System prevents the towing of the GPU if the cable head(s) are not stored and will prevent the GPU from delivering power to the Aircraft unless the Tow bar is in the upright position.

2) Preparation for Storage

A generator set in storage or removed from operation, has special precautions that should be taken to protect internal and external parts from rust, corrosion, and gumming in the engine fuel system.

a) General

Open battery disconnect switch and disconnect battery negative terminal at battery.

- 1) The unit should be prepared for storage as soon as possible after being removed from service.
- 2) The unit should be stored in a building that is dry and can be heated during winter months.
- 3) Moisture-absorbing chemicals should be used where excessive dampness is a problem; however, the unit must be completely packaged and sealed if moisture-absorbing chemicals are to be effective.

Operation Manual ITW GSE 4400 Tier 3

b) Temporary Storage (30 days or less)

- 1) Lubricate unit completely in accordance with instructions in Chapter 2-2. This will include changing engine oil, and all filter elements.
- 2) Start engine and operate a minimum of two minutes so all internal engine components are coated with new oil. (Note: if unit is operated outside of diagnostic mode, it will run for 30 seconds in cool down mode after stop button is pressed.)

NOTE: Do not drain fuel system or crankcase after this run.

- 3) Cooling system antifreeze solution **must** be adequate to protect below lowest temperatures expected during storage period. Be sure solution is thoroughly mixed.
- 4) Clean exterior of engine. Dry with clean rags and compressed air.
- 5) Seal all engine openings. Use water-proof, vapor-proof material strong enough to resist puncture damage from air pressure changes.

c) Long-Term Storage (Over 30 Days)

To protect the generator and other electrical components, the complete unit should be packaged using moisture proof packaging and sealing material. Place containers of moisture-absorbing chemicals in unit before packaging.

From the Cummins 4BT shop manual: long term storage is up to 24 months. Change the oil and fill with 30W Preservative oil. Then start the engine with clean diesel fuel (the units needs to be filled with at least 10% or more of fuel in order to start) and then switch fuel lines to a can of preservative oil (Cummins specifies Dauber Chemical NoxRust # 518). When the preservative oil is running out the injector return tube turn off the motor and cap ends of fuel return and supply tubes. Drain 30W preservative oil from crankcase. Add rust inhibitor to the coolant and make sure that the radiator is full. Spray preservative oil into intake and exhaust ports on cylinder head and under rocker housing covers. Cover all openings. Do not rotate crankshaft. Drain the fuel tank.

The unit can be stored for long periods without the above preparation if engine can be operated once a week.

When operating once a week:

- 1) Make certain the cooling system is adequately protected.

WARNING

ENSURE adequate ventilation before starting the engine.

- 2) Start engine and operate under full load (using a resistive load bank or aircraft) until coolant temperature has reached a minimum 176°F (80°C).
- 3) While engine is running, ensure normal operating controls are in good working condition before shutdown and storage. If weekly operation is not possible, contact nearest engine manufacturer distributor for instructions.

3) Preparation for Shipment

- a) Disconnect battery negative terminal before shipping.
- b) During long shipments, vibration, jolting, etc may loosen the generator set retaining hardware.

CAUTION

When shipping unit, provide sufficient retaining materials to ensure generator set cannot roll out or off the vehicle in which it is being transported.

NOTE: It is suggested strong banding is used to secure generator set.

Operation Manual – ITW GSE 4400 Tier 3

Section 3 Operation

1) General

This section contains information and instructions for safe and efficient operation of the equipment. Operating instructions are presented in systematic sequence of procedures to be followed in supplying 400-Hz or 28.5 VDC power.

NOTE: Read ALL operating instructions before attempting operation of equipment.

WARNING

Ear protection equipment may be necessary when working close to this equipment.

2) 400 Hz. Operating Procedure

a) Pre-start Inspection

- 1) Check engine and generator compartments to make certain they are free of rags or other foreign materials.
- 2) Make certain sufficient lubricating oil and coolant is in the engine.
- 3) Be sure that the battery isolation switch is closed, ensuring that 24 VDC power is available to the engine starting and control systems.
- 4) Make certain the control panel is on. If not, press the Power ON/Engine Start-Stop button to wake the unit.

b) Engine Starting Procedures

CAUTION

Refer to operating instructions in the engine manufacturer's operation manual (provided with the unit), when starting engine for the first time.

- 1) Press and release engine "Start" button. The remaining portion of the startup procedure is automated. Startup status is shown on the display. The procedure will begin by providing power to the engine and other vital components. Next it will check the engine to insure proper operation. Once verified, the engine data begins processing and the engine will start its initialization and warmup procedures. When finished, the starter will begin to crank.
- 2) If the Idle Mode is active (default), once the engine starts it will quickly ramp to idle speed of 1,000 RPM and hold until an output pushbutton is pressed or the unit runs out of fuel.
- 3) If the Idle Mode is inactive, the engine starts and ramps up to its idle speed of 1,000 RPM pauses for a moment and then continues to ramp up to its running speed of 2,000 RPM and stays there until an output pushbutton is pressed or the unit runs out of fuel.
- 4) Once the engine is running at idle or rated speed, check the oil pressure to make certain it is normal and observe all other engine values on the display screen for normal operation.

CAUTION

Never use an ether start system in conjunction with the air intake heater.

Operation Manual – ITW GSE 4400 Tier 3

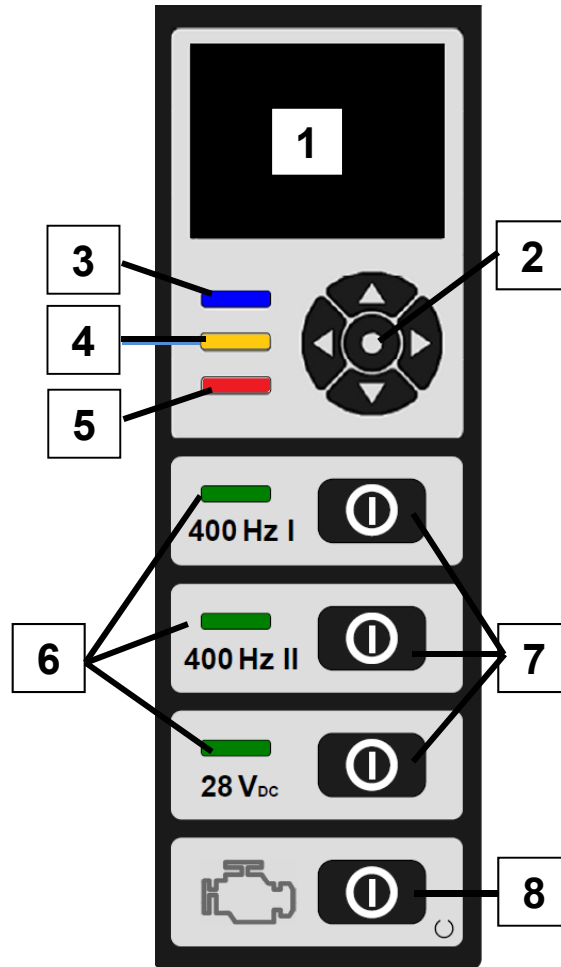

- | | |
|--------------------------|---|
| 1. LED Graphical Display | 5. Alert/Failure "Red" LED |
| 2. Navigation Keypad | 6. Output ON "Green" LEDs |
| 3. Power ON "Blue" LED | 7. Output ON/OFF (Reset) * |
| 4. Warning "Amber" LED | 8. Power ON & Engine Start/Stop (Reset) * |

* All output and engine buttons are multitasking buttons dependent on the status of the unit. The displayed screen is NOT important. These buttons are always active.

CAUTION

To eliminate the possibility of wet stacking (See Appendix C), DO NOT allow the engine to idle for long periods.

c) Failed Starting Procedure

If an error during initialization occurs the engine fails to start after 3 automatic attempts (15 seconds crank, 15 seconds wait per attempt), the display will show a fault. Diagnose and treat the reason for the fault, clear the fault, and press the engine start button again.

Operation Manual – ITW GSE 4400 Tier 3

d) Power Delivery

After the engine has started and the display has changed to the output status default screen, any output ON/OFF buttons can be pressed. If the unit is already at rated speed, the contactor will immediately close. If at idle speed the engine will ramp up to rated speed, the generator will set output voltage and the contactor will close. The green LED will turn ON next to the active output. In addition, current power status information will appear on the output status default screen.

WARNING

All output ON/OFF buttons are active regardless of the displayed screen.

- 1) Early in the power delivery run it is recommended that the operator check output voltage and current in each of the three phases. Use ▼ ▲ pushbuttons to view either the line-to-line or line-to-neutral voltage. If the load is changing, observe the display until load conditions stabilize.
- 2) A condition of over-voltage, under-voltage, under-frequency, over-frequency, or overload in the output circuit will automatically open the load contactor and display a fault code to signal the operator which of the above faults caused the protective monitor system to operate. After the fault has been corrected, press the respective output pushbutton to reset the system. Proceed with power delivery by pressing the same switch.

WARNING

NEVER disconnect the output cable while power is being delivered. Output contactor's must be open prior to removal of the cable from the aircraft.



CAUTION

The generator set must be shut down so the failed power delivery problems can be diagnosed. Only personnel who are trained or qualified on this type of equipment should work on this GPU.

e) Failed Power Delivery

If the contactor indicator light goes out and EF fault is shown on the display, this indicates the aircraft is not supplying the 28.5 VDC interlock signal to the plug interlock circuit. Correct the condition and press the output pushbutton to reset the fault. Press the button again to close the output contactor and provide 400Hz to the aircraft/load bank.

If the aircraft (or load bank) does not provide a 28.5 VDC signal, set the **EF Bypass ON** through the Setup Icon menu.

- 1) Press and hold ● for approximately 5 seconds. (See paragraph 4.23 if this step doesn't result in the Icon menu being displayed.)
- 2) Use the navigation keys (◀▼▲▶) to highlight the setup icon.  Press ● to select.
- 3) Use the navigation keys (▼▲) to highlight the 400 Hz EF Interlock line. Press ● to select.
- 4) Set the 400 Hz EF interlock to bypass.
- 5) Press ● to accept the change.
- 6) Use the ◀ navigation key to go back to the Icon screen.
- 7) Use the navigation keys (◀▼▲▶) to highlight the  setup icon. Press ● to select.
- 8) The display will return to the default screen after a period of inactivity.

Operation Manual – ITW GSE 4400 Tier 3

f) Discontinue Power Delivery with Unit Shutdown

1) Normal conditions

Push the Output ON/OFF pushbutton next to the lit green LED indicator to open the output load contactor. The indicator light next to the button will go OFF, indicating the load contactor has opened and power is no longer being delivered to the aircraft.

Once all contactors are opened:

- a) If Idle Mode option is active (default), the generator will turn off and the engine will return to idle speed after a 5 second delay.
- b) If Idle Mode is inactive, the generator will turn off and the engine will remain at rated speed.
- c) Pushing the engine Start/Stop pushbutton once while the engine is running begins the automatic shutdown sequence which will shut off the engine after 30 seconds.
- d) If the Engine Shutdown option is active, ten minutes after all outputs are opened (OFF) the engine will slow to idle speed and 30 seconds later it will shut down.

2) Emergency conditions

- a) Depress the “**EMERGENCY STOP BUTTON**” located on front of the unit to the right of the control panel. When pushed, this button shuts the generator set off. Pull the button back out to reset it before restarting the generator set.

CAUTION

Do not use the “**EMERGENCY STOP BUTTON**” as a normal shutdown device. Damage to the engine turbo charger may result without proper cooling time. Use the Engine ON/OFF pushbutton for all normal engine shutdowns.

- b) A condition of over-voltage, under-voltage, under-frequency, over-frequency, or overload in the output circuit will automatically open the load contactor and display a fault code to signal the operator which of the above faults caused the protective monitor system to operate. After the fault has been corrected, press the respective output pushbutton to reset the system. Proceed with power delivery by pressing the same switch.

g) Low Fuel Warning and Fault

- 1) A Low Fuel Warning occurs when the unit is running and fuel levels drops below 10% in the fuel tank. The unit will continue to operate until it is out of fuel or the operator shuts off the engine.
- 2) A Low Fuel Fault will display if the fuel level is below 10% and the engine is off. The engine can't be started until the fuel level is above 10%.

h) Display

- 1) The display will automatically turn off if the engine has been off at least 10 minutes. Pushing any button will return the display to full brightness. However, if there is a warning or fault message on the display, it will not turn off.
- 2) If the display is off, and the battery disconnect switch is closed, press the Engine pushbutton to return the display to full brightness.

Operation Manual – ITW GSE 4400 Tier 3

i) Battery Disconnect Switch

If the unit is not going to be used for a long period of time, open the battery disconnect switch to remove 24 VDC power to the control board and Cummins ECM controller. **DO NOT** open the battery disconnect switch while the engine is running or within two minutes after the engine has shut down.

3) Active Rectifier Unit (ARU) – 28.5 VDC Power Supply

a) See Appendix A for ARU Operation

CAUTION

The ARU can deliver up to 2,400 amps of current during the starting of an aircraft engine. This much current will shear the propeller shaft of some aircraft. Therefore, make sure that the current limit is correctly set for the aircraft that is being powered.

Operation Manual – ITW GSE 4400 Tier 3

4) Icon Menu

The Icon Menu is accessed from the default screen. Press the center navigation button ● while in the default menu and hold it down for approximately 5 seconds. (If the Icon menu doesn't appear after 5 seconds, see paragraph 4.23 below to unlock access to the Icon menu.)

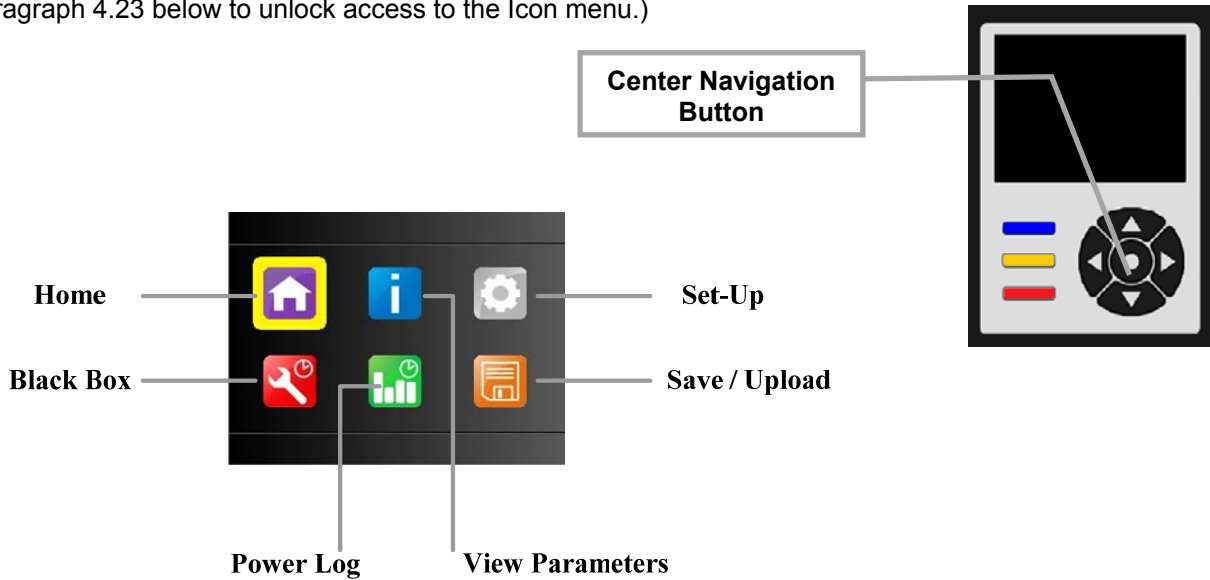







The basic Icon Menu is shown above with the available sub-menus.

To enter the Icon Menu, press the ● from the default menu and hold it down for approximately 5 seconds.

To Select a sub-menu, simply use the navigation keys ◀▼▲▶ to highlight the icon and then press the ● to enter the sub-menu.

To leave the Icon Menu highlight the "Home" icon and press ●

Icon explanation:

-  Back to Default screen
-  Viewing actual converter parameters
-  Set-up menu for changing converter parameters
-  Black Box with last 100 failures / errors
-  Power Log with last 100 operations
-  Save "Black Box" / "Power Log" records or update control card software

Operation Manual – ITW GSE 4400 Tier 3

a) View Parameters Menu

The View Parameters Menu is accessed from the Icon screen. Press the center navigation button ● while in default menu and hold down for approximately 5 seconds. The Icon menu is displayed, press the right navigation button to highlight the icon.

Parameters – Menu structure

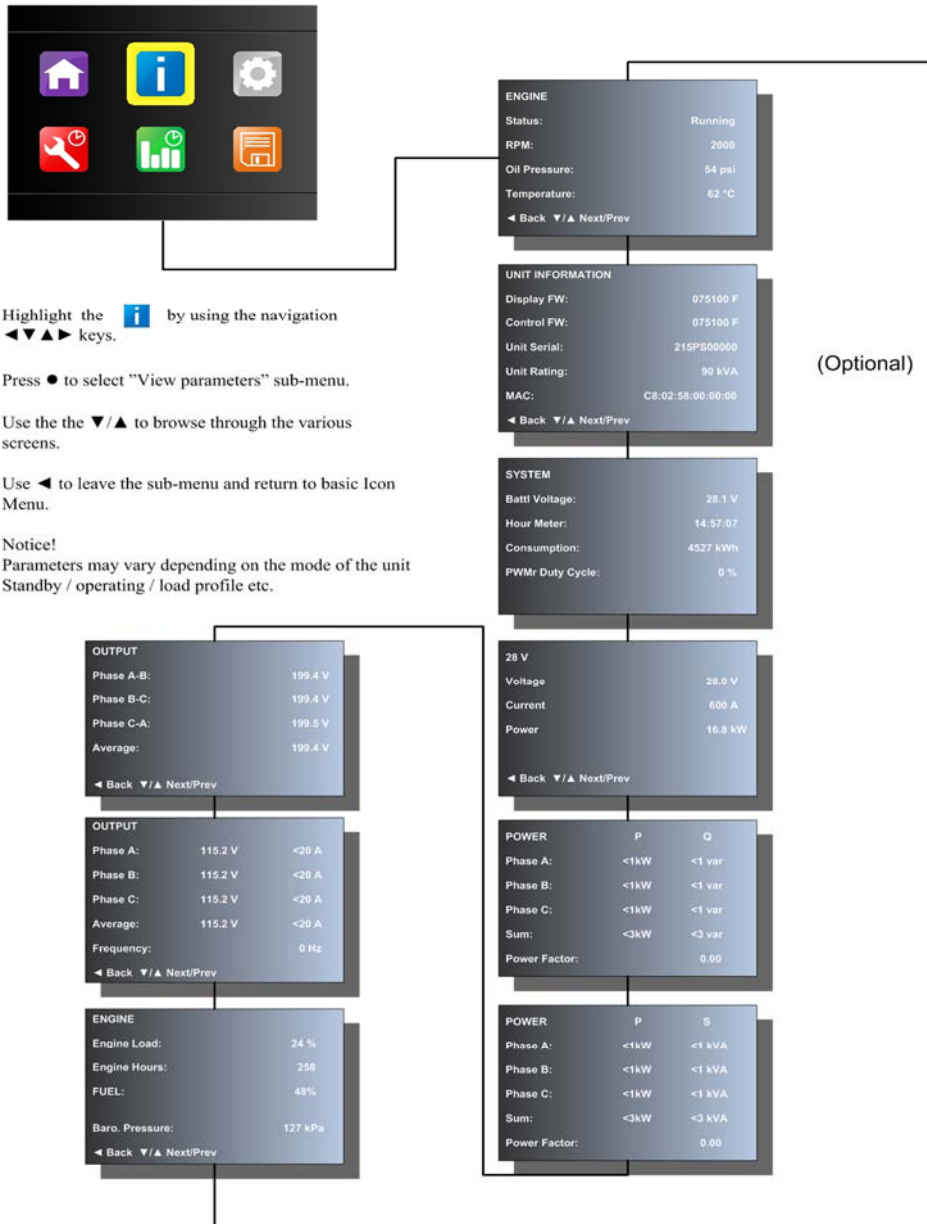

Operation Manual – ITW GSE 4400 Tier 3

b) Setup Menu

The Setup Menu is accessed from the Icon screen. Press the center navigation button ● while in the default menu and hold down for approximately 5 seconds. The Icon menu is displayed, press the right navigation button to highlight the Setup icon.

Setup – Menu structure

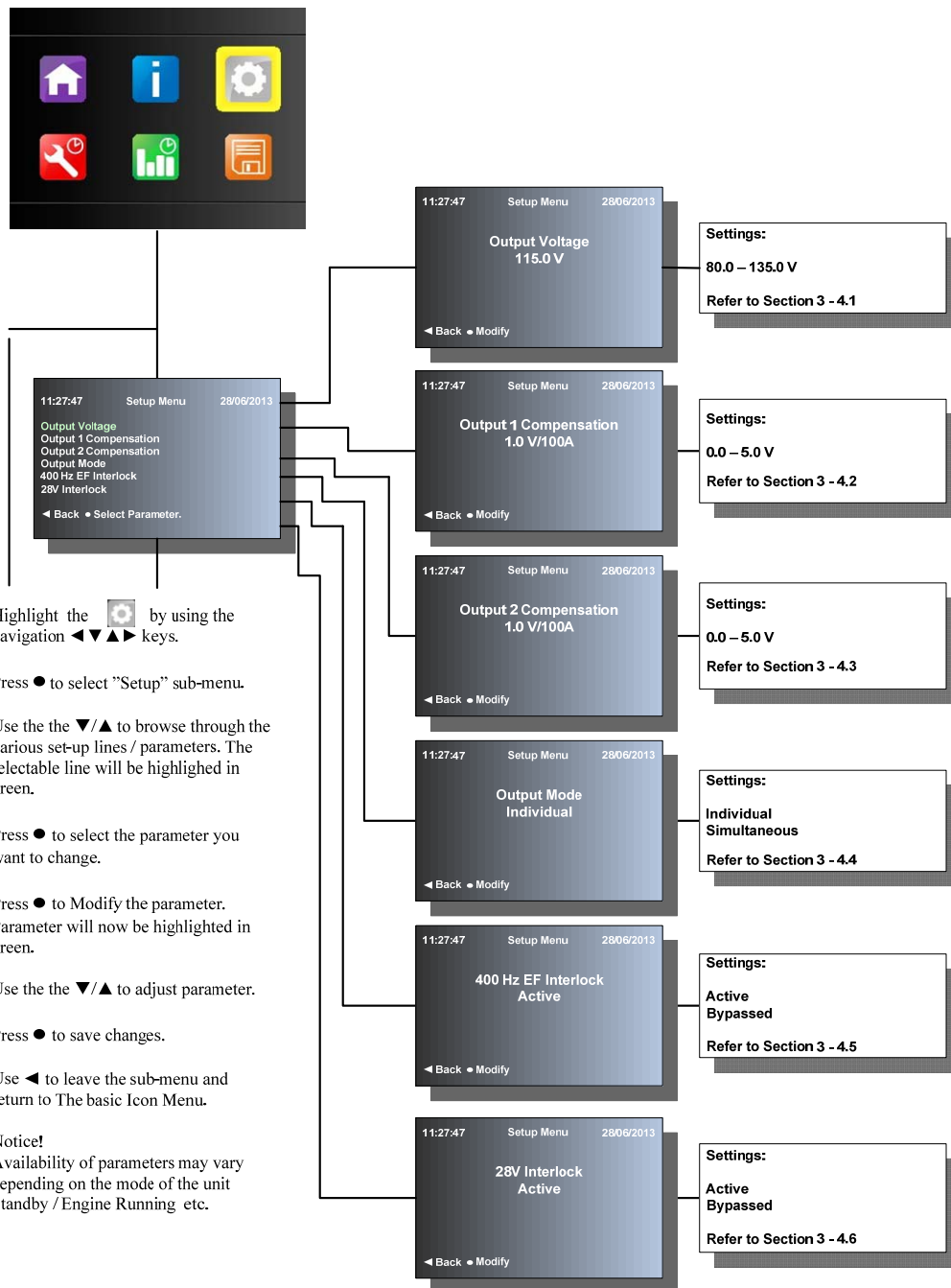

Highlight the by using the navigation ◀▶▲▼ keys.

Press ● to select "Setup" sub-menu.

Use the the ▼/▲ to browse through the various set-up lines / parameters. The selectable line will be highlighted in green.

Press ● to select the parameter you want to change.

Press ● to Modify the parameter. Parameter will now be highlighted in green.

Use the the ▼/▲ to adjust parameter.

Press ● to save changes.

Use ◀ to leave the sub-menu and return to The basic Icon Menu.

Notice!
Availability of parameters may vary depending on the mode of the unit Standby / Engine Running etc.

Operation Manual – ITW GSE 4400 Tier 3

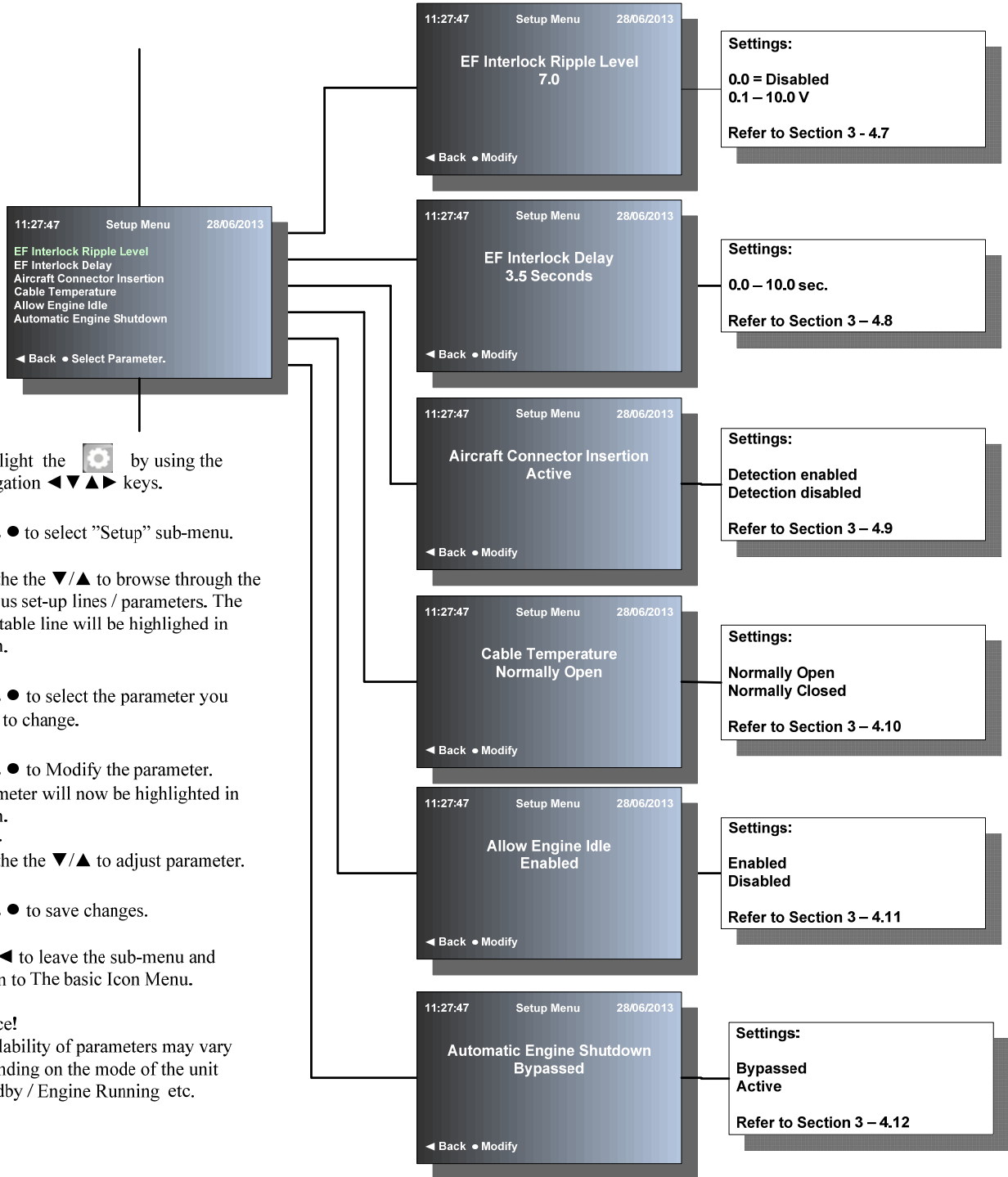

Highlight the  by using the navigation **◀▼▲▶** keys.

Press **●** to select "Setup" sub-menu.

Use the the **▼/▲** to browse through the various set-up lines / parameters. The selectable line will be highlighted in green.

Press **●** to select the parameter you want to change.

Press **●** to Modify the parameter. Parameter will now be highlighted in green.

Use the the **▼/▲** to adjust parameter.

Press **●** to save changes.

Use **◀** to leave the sub-menu and return to The basic Icon Menu.

Notice!
Availability of parameters may vary depending on the mode of the unit Standby / Engine Running etc.

Operation Manual – ITW GSE 4400 Tier 3

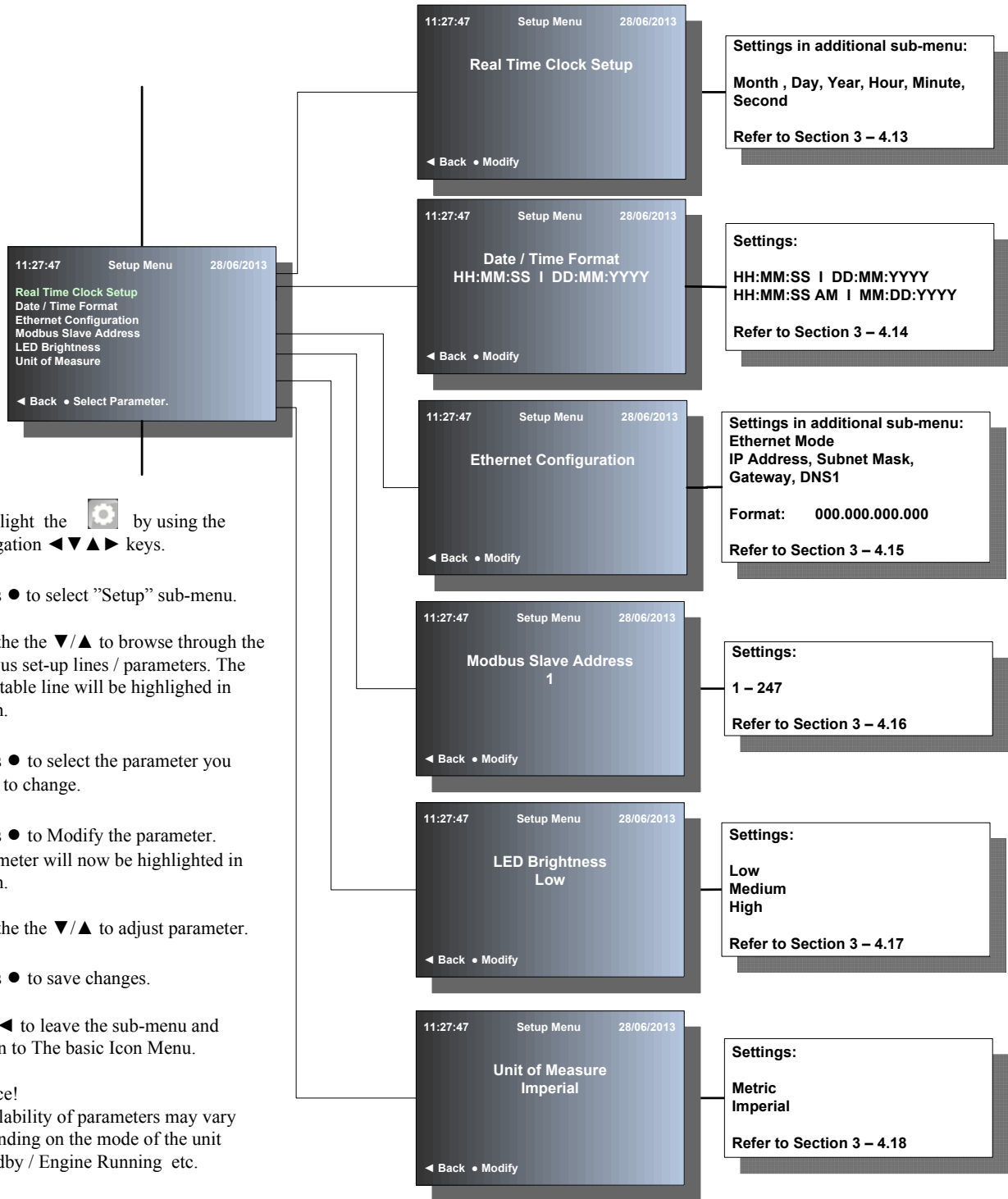

Highlight the  by using the navigation ◀▶▲▼ keys.

Press ● to select "Setup" sub-menu.

Use the the ▼/▲ to browse through the various set-up lines / parameters. The selectable line will be highlighted in green.

Press ● to select the parameter you want to change.

Press ● to Modify the parameter. Parameter will now be highlighted in green.

Use the the ▼/▲ to adjust parameter.

Press ● to save changes.

Use ◀ to leave the sub-menu and return to The basic Icon Menu.

Notice!
Availability of parameters may vary depending on the mode of the unit Standby / Engine Running etc.

Operation Manual – ITW GSE 4400 Tier 3

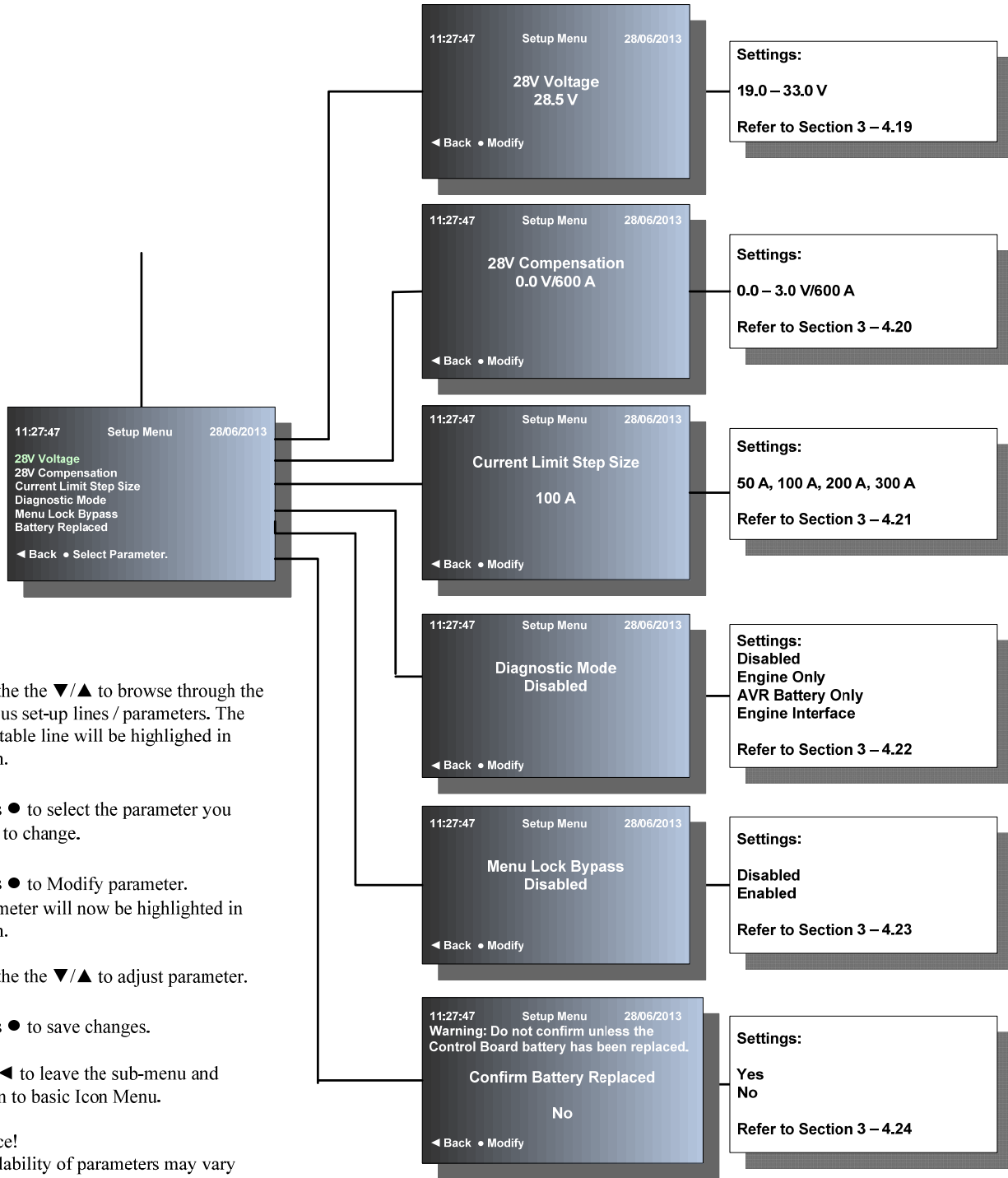

Use the the ▼/▲ to browse through the various set-up lines / parameters. The selectable line will be highlighted in green.

Press ● to select the parameter you want to change.

Press ● to Modify parameter. Parameter will now be highlighted in green.

Use the the ▼/▲ to adjust parameter.

Press ● to save changes.

Use ◀ to leave the sub-menu and return to basic Icon Menu.

Notice!
Availability of parameters may vary depending on the mode of the unit Standby / Engine Running etc.

Operation Manual – ITW GSE 4400 Tier 3

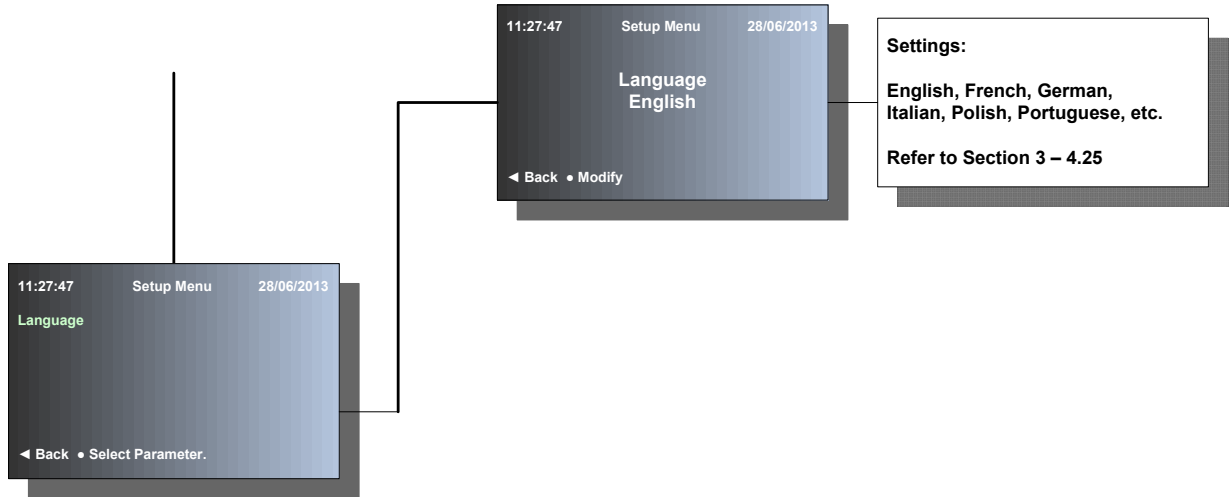

Use the the ▼/▲ to browse through the various set-up lines / parameters. The selectable line will be highlighted in green.

Press ● to select the parameter you want to change.

Press ● to Modify parameter.
Parameter will now be highlighted in green.

Use the the ▼/▲ to adjust parameter.

Press ● to save changes.

Use ◀ to leave the sub-menu and return to basic Icon Menu.

Notice!
Availability of parameters may vary depending on the mode of the unit Standby / Engine Running etc.

1) Output Voltage

This Setup submenu allows the output voltage to be adjusted between 80.0 VAC and 135 VAC using the UP and DOWN navigation buttons. (Please note that the acceptable voltage range for all commercial aircraft is 115V ±3V. This range is even tighter for some aircraft.)

Operation Manual – ITW GSE 4400 Tier 3

Enter the Setup Menu and then scroll up or down to the Output Voltage submenu. Press the center ● button to enter the submenu, and then press the ● button again to allow the value to be changed. Press the up or down arrow buttons to change the selection. Press the center ● button to record the new value. Press the LEFT arrow button to exit the submenu and return to the submenu list.

2) Output 1 Compensation

The output voltage is increased in proportion to the load current (Volt / 100 A).

- a) Apply full load to output 1.
- b) Enter the “OUTPUT 1 COMPENSATION” submenu. Press the center button to allow the value to be adjusted.
- c) Adjust the compensation using the vertical arrow buttons until the voltage at the aircraft connector equals the no load value. Press center ● button to accept and record this value. Press the LEFT arrow button to exit the submenu and return to the submenu list.

3) Output 2 Compensation:

The output voltage is increased in proportion to the load current (Volt / 100 A).

- a) Apply full load to output 2.
- b) Enter the “OUTPUT 2 COMPENSATION” submenu. Press the center button to allow the value to be adjusted.
- c) Adjust the compensation using the vertical arrow buttons until the voltage at the aircraft connector equals the no load value. Press center ● button to accept and record this value. Press the LEFT arrow button to exit the submenu and return to the submenu list.

4) Output Mode

- a) When the unit has 2 outputs, the “Output Mode” submenu is used to set either “Individual” or “Simultaneous” mode of operation.
- b) If the output mode has been set to “Individual”, the outputs can be used individually. If the output mode has been set to “Simultaneous”, both outputs can be used at the same time.
- c) Enter the Setup Menu and then scroll up or down to the Output Mode submenu. Press the center ● button to enter the submenu, and then press the ● button again to allow the value to be changed. Press the up or down arrow buttons to change the selection. Press the center ● button to record the new value. Press the LEFT arrow button to exit the submenu and return to the submenu list.

5) 400 Hz EF Interlock

- a) The EF interlock is a personnel and equipment safety feature that is found in all commercial aircraft. This 28VDC signal will not be present until the GPU closes its output contactor and provides 400 Hz power to the aircraft. The aircraft will evaluate the 400 Hz power and if it is within the aircrafts tolerance limits it will then close a relay in the aircraft to provide a 28VDC signal to the “F” pin/wire in the power connector plug/cable.
- b) Some load banks do not provide this EF Interlock so the EF interlock function in the unit has to be bypassed. Do not set this value to Bypassed for normal operation with aircraft. This setting is only to be used by qualified personnel for testing the GPU unit or when the unit will be providing power to equipment outside of an aircraft.

Note! The value will be automatically reset to Active if the unit detects 28 volts on the "F" pin input of the I/O board.

- c) Go into the Setup Menu and then scroll up or down to the EF Interlock submenu. Press the center ● button to enter the submenu, and then press the ● button again to allow the value to be changed. Press the up or down arrow buttons to change the selection. Press the center ● button to record the new value. Press the LEFT arrow button to exit the submenu and return to the submenu list.

Operation Manual – ITW GSE 4400 Tier 3

6) 28V Interlock

- a) The 28V interlock is a personnel and equipment safety feature that is found on some commercial turboprop aircraft. This 28VDC signal will not be present until the GPU closes its output contactor and provides power to the aircraft connector. The connector typically has a split "F" socket with +28VDC on one side and a jumper to the return wire on the other side of the socket. The GPU will not keep the output contactor closed if this voltage is not detected on the return wire in the cable. (This option requires a special cable such as the JB2840-30CS, JB2840-40CS or JB2840-50CS.)

Note! The value will be automatically reset to Active if the unit detects 28 volts on the "F" pin input of the I/O board.

- b) Go into the Setup Menu and then scroll up or down to the 28V Interlock submenu. Press the center ● button to enter the submenu, and then press the ● button again to allow the value to be changed. Press the up or down arrow buttons to change the selection. Press the center ● button to record the new value. Press the LEFT arrow button to exit the submenu and return to the submenu list.

7) EF Interlock Ripple Level

- a) The EF Interlock Ripple Level is part of the Neutral Voltage Displacement circuit. If an aircraft has a large unbalanced load and the aircraft power cable has a broken neutral, then it is possible for the aircraft frame to be energized to a dangerous level. This condition will result in an AC voltage induced onto the EF DC signal.
- b) This sub-menu sets the trip level for the AC ripple on the DC EF interlock signal. The default value is 7.0 volts and a setting of 0.0 volts disables the function.
- c) Go into the Setup Menu and then scroll up or down to the EF Interlock Ripple Level submenu. Press the center ● button to enter the submenu, and then press the ● button again to allow the value to be changed. Press the up or down arrow buttons to change the selection. Press the center ● button to record the new value. Press the LEFT arrow button to exit the submenu and return to the submenu list.

8) EF Interlock Delay

- a) Some of the newer aircraft take a longer time between when 400 Hz power is supplied to the aircraft and when the aircraft returns the 28 VDC EF Interlock signal. This setting allows the adjustment of the amount of time the unit will wait until determining that the EF signal is not present and that the output power should be shut off. The default value is 3.5 seconds.
- b) Go into the Setup Menu and then scroll up or down to the EF Interlock Delay submenu. Press the center ● button to enter the submenu, and then press the ● button again to allow the value to be changed. Press the up or down arrow buttons to change the selection. Press the center ● button to record the new value. Press the LEFT arrow button to exit the submenu and return to the submenu list.

9) Aircraft Connector Insertion

- a) Some aircraft power cables are equipped with a micro-switch or split "F" socket in the connector. This device sends a 28 VDC signal to the unit when the connector is inserted at least 90% of the way into the aircraft power receptacle. Set this sub-menu value to Enable when such a cable is connected to the unit. The default value is set to Disable.
- b) Go into the Setup Menu and then scroll up or down to the Aircraft Connector Insertion submenu. Press the center ● button to enter the submenu, and then press the ● button again to allow the value to be changed. Press the up or down arrow buttons to change the selection. Press the center ● button to record the new value. Press the LEFT arrow button to exit the submenu and return to the submenu list.

Operation Manual – ITW GSE 4400 Tier 3

10) Cable Temperature

- a) Some aircraft cables have temperature sensors installed in the connector body and/or replaceable nose. This sub-menu allows the unit to accept Normally Opened or Normally Closed temperature sensor switches to be used.
- b) Go into the Setup Menu and then scroll up or down to the Plug Temperature submenu. Press the center ● button to enter the submenu, and then press the ● button again to allow the value to be changed. Press the up or down arrow buttons to change the selection. Press the center ● button to record the new value. Press the LEFT arrow button to exit the submenu and return to the submenu list.

11) Allow Engine Idle

When this option is set to Enable, the engine will ramp up to its idle speed (1,000 RPM) and wait for an output to be turned on. Once an output is turned on, the unit will ramp up to its running speed (2,000 RPM) and energize the generator and close the selected output contactor when the generator is stabilised. The unit will return to idle speed five seconds after all outputs are turned off.

Enter the Setup Menu and then scroll up or down to the Allow Engine Idle submenu. Press the center ● button to enter the submenu, and then press the ● button again to allow the value to be changed. Press the up or down arrow buttons to change the selection. Press the center ● button to record the new value. Press the LEFT arrow button to exit the submenu and return to the submenu list.

12) Automatic Engine Shutdown

If the engine is running at its rated speed and all outputs are off for ten (10) minutes or the total load is less than 5 amps, the engine will automatically go into its 30 second shutdown mode when this function is active. The Setup submenu allows this option to be activated or bypassed.

Enter the Setup Menu and then scroll up or down to the Automatic Engine Shutdown submenu. Press the center ● button to enter the submenu, and then press the ● button again to allow the value to be changed. Press the up or down arrow buttons to change the selection. Press the center ● button to record the new value. Press the LEFT arrow button to exit the submenu and return to the submenu list.

13) Real Time Clock Setup

This set of sub-menu s allows the user to adjust the internal clock to the correct local time.

Go into the Setup Menu and then scroll up or down to the Real-Time Clock Setup submenu. Press the center ● button to enter the submenu, and then press the ● button again to allow the value to be changed. Press the up or down arrow buttons to change the selection. Press the center ● button to record the new value. Press the LEFT arrow button to exit the submenu and return to the submenu list.

14) Date/Time Format

The date and time format that is displayed on all the screens and reports can be adjusted using this submenu. The selection is a 24 hour clock and DD:MM:YYYY date format or a 12 hour clock with the MM:DD:YYYY date format.

Go into the Setup Menu and then scroll up or down to the Date/Time Format submenu. Press the center ● button to enter the submenu, and then press the ● button again to allow the value to be changed. Press the up or down arrow buttons to change the selection. Press the center ● button to record the new value. Press the LEFT arrow button to exit the submenu and return to the submenu list.

15) Ethernet Configuration

This set of sub-menu s allows the user to enter the Ethernet IP address, Subnet Mask, Gateway address and DNS1 values for TCP/IP communications with a BMS or RMS central monitoring system.

Go into the Setup Menu and then scroll up or down to the Ethernet Configuration submenu. Press the center ● button to enter the submenu, and then press the ● button again to allow the value to be changed. Press the up or down arrow buttons to change the selection. Press the center ● button to record the new value. Press the LEFT arrow button to exit the submenu and return to the submenu list.

Operation Manual – ITW GSE 4400 Tier 3

16) Modbus Slave Address

If the unit will be part of an RS-485 Modbus RTU BMS/RMS monitoring system, it must be assigned a Modbus Slave Address. This sub-menu allows the user to enter the slave address.

Go into the Setup Menu and then scroll up or down to the Modbus Slave Address submenu. Press the center ● button to enter the submenu, and then press the ● button again to allow the value to be changed. Press the up or down arrow buttons to change the selection. Press the center ● button to record the new value. Press the LEFT arrow button to exit the submenu and return to the submenu list.

17) LED Brightness

The unit status LED's have three brightness levels. The default is set to medium.

Go into the Setup Menu and then scroll up or down to the LED Brightness submenu. Press the center ● button to enter the submenu, and then press the ● button again to allow the value to be changed. Press the up or down arrow buttons to change the selection. Press the center ● button to record the new value. Press the LEFT arrow button to exit the submenu and return to the submenu list.

18) Unit of Measure

This submenu is used to set the unit of measurements to Metric or Imperial.

Go into the Setup Menu and then scroll up or down to the Unit of Measure submenu. Press the center ● button to enter the submenu, and then press the ● button again to allow the value to be changed. Press the up or down arrow buttons to change the selection. Press the center ● button to record the new value. Press the LEFT arrow button to exit the submenu and return to the submenu list.

19) 28V Voltage

This Setup submenu allows the 28 volt output to be adjusted between 19.0 VDC and 33.0 VDC using the UP and DOWN navigation buttons. (Please note that the acceptable voltage range for all commercial DC powered aircraft is 26V to 29V.

Enter the Setup Menu and then scroll up or down to the ARU Voltage submenu. Press the center ● button to enter the submenu, and then press the ● button again to allow the value to be changed. Press the up or down arrow buttons to change the selection. Press the center ● button to record the new value. Press the LEFT arrow button to exit the submenu and return to the submenu list.

20) 28V Compensation

DC voltage drops quickly as the current increases over a given length of cable. This Setup submenu allows the 28 volt output to be automatically adjusted as the load increases. The allowed setting is between 0.0 and 3.0 VDC at the rated continuous load of the unit. Note that the maximum output voltage of the unit is 33 VDC.

Enter the Setup Menu and then scroll up or down to the 28V Compensation submenu. Press the center ● button to enter the submenu, and then press the ● button again to allow the value to be changed. Press the up or down arrow buttons to change the selection. Press the center ● button to record the new value. Press the LEFT arrow button to exit the submenu and return to the submenu list.

21) Current Limit Step Size

If too much current is supplied to an aircraft engine, it is possible for the engine to shear the propeller shaft. The Current Limit should be set to the maximum current the aircraft to be powered can take (per the aircraft manufacturers recommendations). The Current Limit is set using the UP and Down arrows on the Operators Panel. This submenu is used to set the step size the current limit is changed by every time the UP or Down button is pressed. The current limit settings are from 300 amps to 2000 amps in steps of 50/100/200/300 amps. This menu selects the size of the steps that the operator uses to adjust the current limit before turning on the 28 VDC to the aircraft.

Operation Manual – ITW GSE 4400 Tier 3

Enter the Setup Menu and then scroll up or down to the Current Limit Step Size submenu. Press the center ● button to enter the submenu, and then press the ● button again to allow the value to be changed. Press the up or down arrow buttons to change the selection. Press the center ● button to record the new value. Press the LEFT arrow button to exit the submenu and return to the submenu list.

22) Diagnostic Mode

This setup submenu is used to assist in the troubleshooting procedure. The default setting is “Disabled”; use the “Engine Only” to verify engine performance; use the “AVR Battery Only” to verify the operation of the generator (with engine operation). The “Engine Interface” allows read only access to the engine ECM module. In the “Engine Interface” mode, the engine ECM will perform a self-test and then enter its Run mode. (The display will indicate running in the engine screen). In this mode each of the output contactors can be toggled on and off to verify that they are functioning correctly.

The engine must be stopped before any of these modes can be changed.

Enter the Setup Menu and then scroll up or down to the Diagnostic Mode submenu. Press the center ● button to enter the submenu, and then press the ● button again to allow the value to be changed. Press the up or down arrow buttons to change the selection. Press the center ● button to record the new value. Press the LEFT arrow button to exit the submenu and return to the submenu list.

23) Menu Lock Bypass

This submenu is used to lock out the center button on the navigation keypad which will prevent access to the ICON screen. Disabled allows access to the Icon screen when the center button is pressed for 5 seconds. Enabled locks out the center button. When the center button is pressed the screen will display DISABLED. Technicians can gain temporary access to the Icon menu by performing the following sequence of button presses: Right Arrow, Up Arrow, Down Arrow, Down Arrow. Holding the center button again (approx. 5 seconds) will take you to the main Icon menu. The default is set to disabled.

Go into the Setup Menu and then scroll up or down to the Menu Lock Bypass submenu. Press the center ● button to enter the submenu, and then press the ● button again to allow the value to be changed. Press the up or down arrow buttons to change the selection. Press the center ● button to record the new value. Press the LEFT arrow button to exit the submenu and return to the submenu list.

24) Confirm Battery Replaced

Situated on the back of the control board, is a coin type lithium battery which ensures that Firmware / Set-up data etc. are not lost during utility drop-outs. The expected life of the battery is approximately 7 years. Note, a low battery voltage does not affect the internal safety system of the GPU that monitors the output voltage, among others. Thus, aircraft connected to the GPU are not exposed to any danger. However, to avoid loss of data and Control Board lock up *, we recommend changing the battery after **5 years** of use.

Note!

A time stamp is stored in the ID chip (A6) upon production and after 5 years a warning occurs at the display, telling the user/operator to replace the Control Board battery. It is strongly recommended to change the battery when this message is shown:

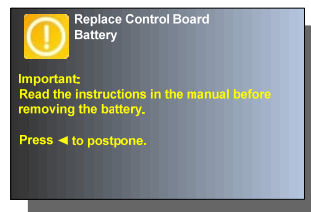

Fig. 8.2.1

Operation Manual – ITW GSE 4400 Tier 3

To allow the user/operator to use the converter, it is possible to postpone the battery change, by pressing the ◀ (left arrow) push button. The warning message occurs 90 seconds after the unit is powered on or the output contactor(s) are opened (the unit is in Standby Mode). If this message is ignored for 6 months, the controls will be locked out and the below failure message will be displayed.

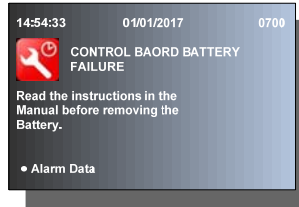

Fig. 8.2.2

The battery must be changed before the unit can be operated again.



To ensure high reliability of the back-up battery, the only type of battery that can be used on the Control Board is the Panasonic BR-2032

Go into the Setup Menu and then scroll up or down to the Confirm Battery Replaced submenu. Press the center ● button to enter the submenu, and then press the ● button again to allow the value to be changed. Press the up or down arrow buttons to change the selection. Press the center ● button to record the new value. Press the LEFT arrow button to exit the submenu and return to the submenu list.

25) Language

This submenu is used to change the language that all of the display screens, messages, alarms and reports are displayed in. The unit comes with English, French, German, Italian, Polish, Portuguese, Czech, Russian, Turkish and Spanish already installed. Other languages can be added as required. The default is set to English.

Go into the Setup Menu and then scroll up or down to the Language submenu. Press the center ● button to enter the submenu, and then press the ● button again to allow the value to be changed. Press the up or down arrow buttons to change the selection. Press the center ● button to record the new value. Press the LEFT arrow button to exit the submenu and return to the submenu list.

Operation Manual – ITW GSE 4400 Tier 3

c) Black Box

Black Box – Menu structure

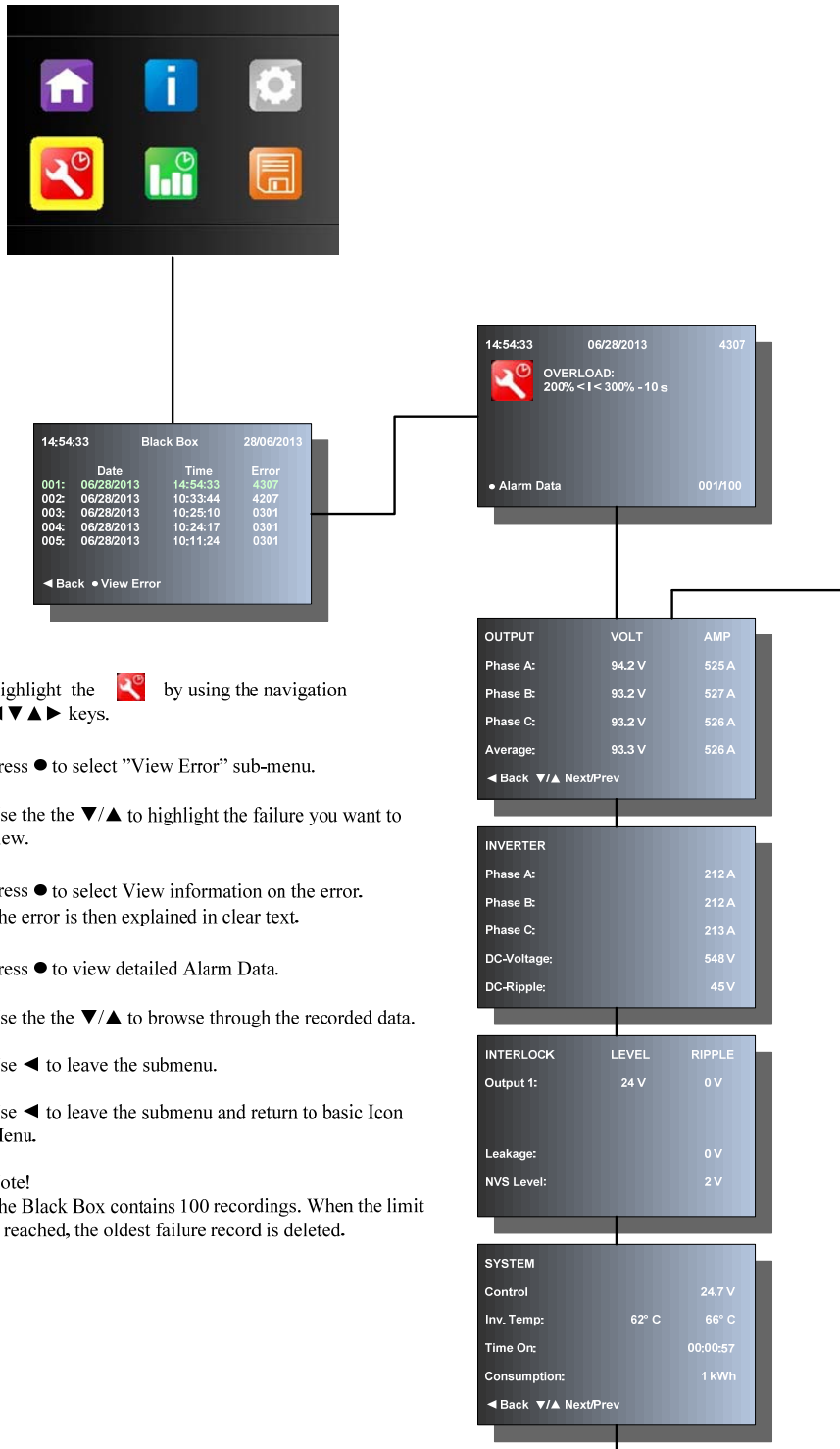

Highlight the by using the navigation **◀▶▶▶▶** keys.

Press **●** to select "View Error" sub-menu.

Use the the **▼/▲** to highlight the failure you want to view.

Press **●** to select View information on the error. The error is then explained in clear text.

Press **●** to view detailed Alarm Data.

Use the the **▼/▲** to browse through the recorded data.

Use **◀** to leave the submenu.

Use **◀** to leave the submenu and return to basic Icon Menu.

Note!
The Black Box contains 100 recordings. When the limit is reached, the oldest failure record is deleted.

Operation Manual – ITW GSE 4400 Tier 3

d) Power Log

The Power Log Menu is accessed from the Icon screen. Press the center navigation button ● while in the default menu and hold it down for approximately 5 seconds. The Icon menu is displayed, press the right navigation button to highlight the Power Log icon.

Power Log – Menu structure



Highlight the  by using the navigation **◀▶▶▶▶** keys.

Press **●** to select "Power Log" sub-menu.

Use the the **▼/▲** to highlight the Power Log you want to view.

Press **●** to select View Log.

The Power Log parameters are then displayed.

Press **●** to select Graph view.

or

Use the the **▼/▲** to browse to the next recorded event.

Use **◀** to leave the sub-menu.

Use **◀** to leave the sub-menu and return to basic Icon Menu.

Notice!

The Power Log contains 100 recordings. When the limit is reached, the oldest Log record is deleted.

Operation Manual – ITW GSE 4400 Tier 3

e) Update/Save Log Menu

The Update/Save Log Menu is accessed from the Icon screen. Press the center navigation button ● while in the default menu and hold it down for approximately 5 seconds. The Icon menu is displayed, press the right navigation button then the down button to highlight the Update/Save Log icon.

Update/Save Log – Menu structure

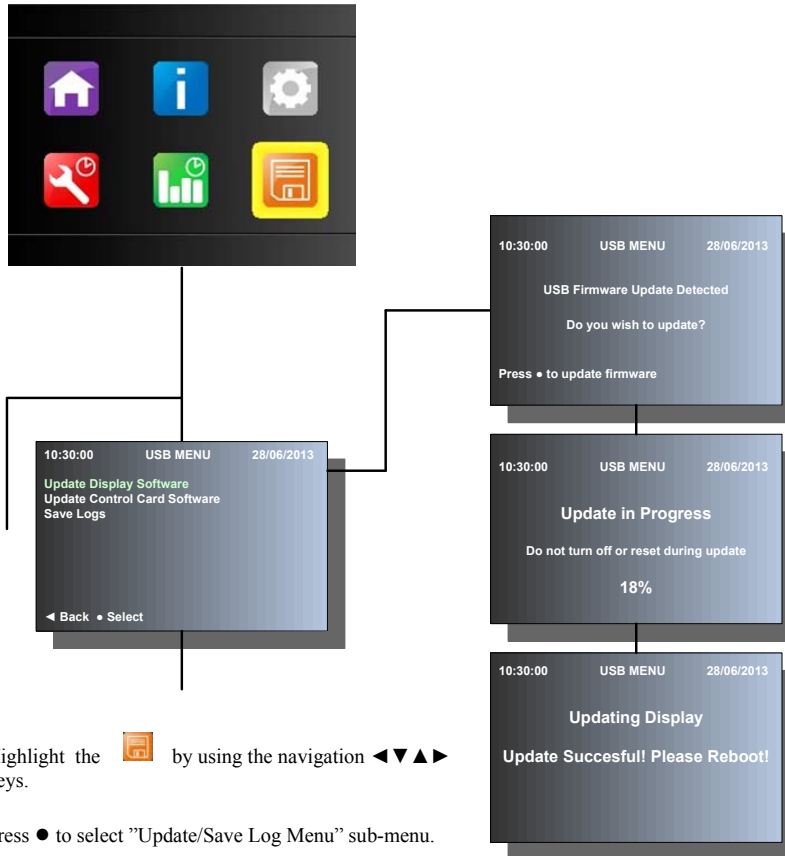

Highlight the  by using the navigation ◀▼▲▶ keys.

Press ● to select "Update/Save Log Menu" sub-menu.

The default function "Update Display Software" is green highlighted. If another function is wanted, use the the ▼/▲ to highlight the function.

Before pressing ● to select "Update Display Software", please remember to insert a USB stick into the USB port on the Display (located on the side of the Display enclosure inside the unit).

Press ● to select the function.

Press ● to confirm update firmware.

The firmware is now being uploaded to the display card. Upload % is counting from 0% to 100%. The system automatically reboots if the update is successful. Otherwise, an Update has failed! Message is displayed.

Operation Manual – ITW GSE 4400 Tier 3

Update/Save Log (continued) – Menu structure

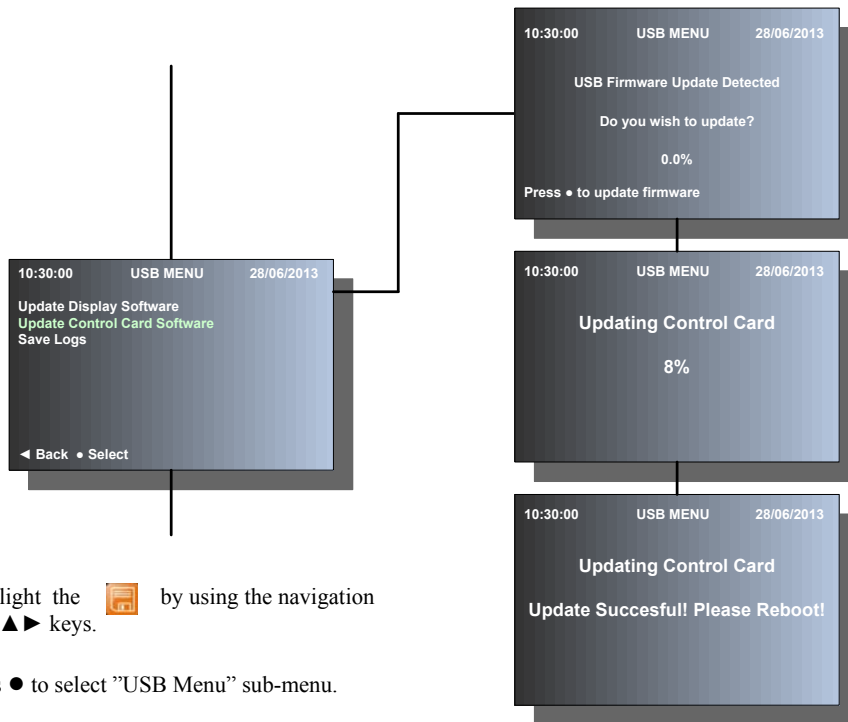

Highlight the  by using the navigation **◀▼▲▶** keys.

Press **●** to select "USB Menu" sub-menu.

Use the the **▼/▲** to highlight the function "Update Control Card software".

Before pressing **●** to select "Update control card software", please remember to insert a USB stick into the USB port on the control card (located on the interface board).

Press **●** to select function.

Press **●** to confirm update firmware.

The firmware is now being uploaded to the display card. Upload % is counting from 0% to 100%. The system automatically reboots if the update is successful. Otherwise, an Update has failed! Message is displayed.

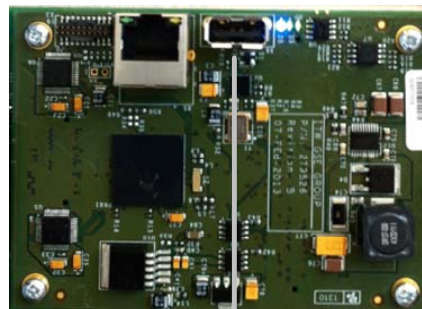

**USB connection
Control card**

Operation Manual – ITW GSE 4400 Tier 3

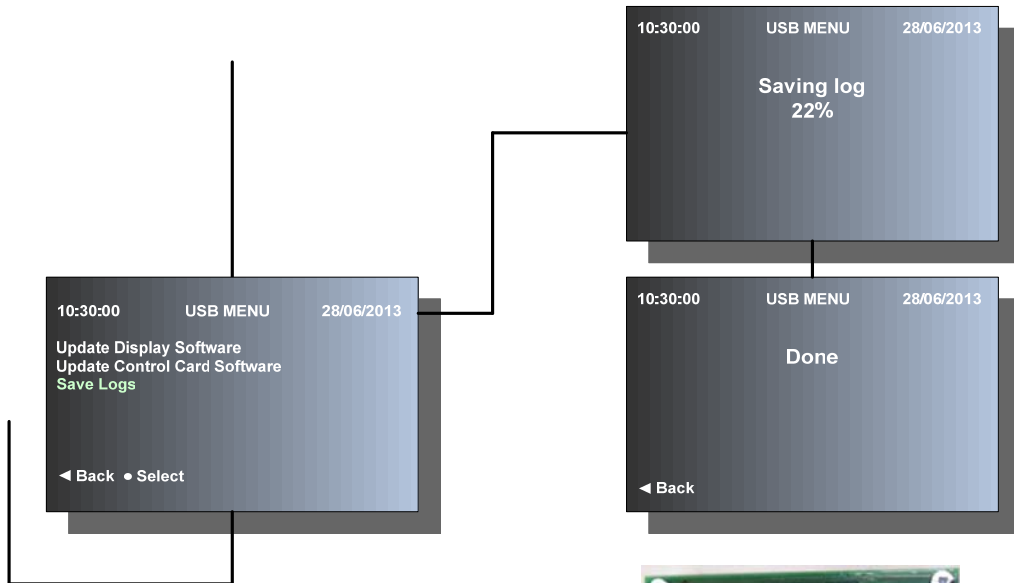

Highlight the  by using the navigation **◀▼▲▶** keys.

Press **●** to select "USB MENU" sub-menu.

Use the the **▼/▲** to highlight the function "Save Logs".

Before pressing **●** to select Save logs, please remember to insert an USB stick into the USB port on the display (located on backside of the front door).

Press **●** to select function.

The logs are now saved to the USB stick. Saving log % is counting from 0% to 100% and "Done" is displayed, when the saving has been completed.

The logs are saved as one CSV File. Use the ITW GSE Service Tool to properly display this file.

Note!

The USB stick can be inserted while the unit is powered.



USB connection Display

Chapter 2 Service and Troubleshooting

Section 1 Maintenance Inspection/Check

1) General

To make certain the generator set is always ready for operation, it must be inspected and maintained regularly and systematically so that defects may be discovered and corrected before they result in serious damage to components, or failure of the equipment.

Warning

STOP operations at once if a serious or possibly dangerous fault is discovered

2) Maintenance Schedule

a) General

A periodic maintenance schedule should be established and maintained. A suggested schedule is provided in Figure 2-1-1 on the following pages. It may be modified, as required to meet varying operating and environmental conditions. It is suggested that generator set and vehicle inspections be coordinated as much as possible.

b) Maintenance Schedule Check Sheet

It is strongly recommended that the customer use a maintenance schedule check sheet such as the one in the engine manufacturer's operation manual. The check sheet will provide a record and serve as a guide for establishment of a schedule to meet the customer's maintenance requirements for his specific operation.

c) Time Intervals.

The schedule is based on both hours of operation and calendar intervals. These two intervals are not necessarily the same. For example, in normal operation the oil change period, based on hours of operation, will be reached long before the three months calendar period. The calendar period is included to make certain services are performed regularly when the equipment is stored, or being operated infrequently. Lubricating oil standing in engines that are stored, or used very little, may tend to oxidize and may require changing although it is not dirty. Perform all services on a whichever- comes-first basis.

d) Identification of Interval Periods.

Each interval period is identified by a letter A, B, C, etc. For example, services under B schedule should be performed at the end of each 250 hours of operation, or every three months, BR service is performed during the BREAK IN period (first 50-150 hours), G service is Extended Life (10,000 + hours) and AR service is performed AS REQUIRED.

Operation Manual – ITW GSE 4400 Tier 3

Hourly Interval	AR	50-150	10	250	500	1000	1500	2000
Calendar Interval		Once	Daily	3 Mo.	6 Mo.	1 Yr.	1.5 Yr.	2 Yr.
Symbol	AR	BR	A	B	C	D	E	F
Engine								
Change Air Cleaner Cartridge	X							
Check Coolant Hose and Clamps	X							
Check Crankcase Oil Level			X					
Drain Fuel PreFilter Elements			X					
Check Coolant Level			X					
Check for Leaks and Correct		X	X					
Check Air Cleaner Indicator			X					
Check Exhaust System	X		X					
Charge-Air-Cooler (CAC) and Piping				X				
Change Lubricity Fuel Filter Element		X			X			
Check Radiator Core and Hoses				X				
Check Oil Pressure and Record				X				
Change Crankcase Oil		X			X			
Change Oil Filter Element		X			X			
Check Engine and Generator Mounts		X			X			
Check Coolant, Additive-Concentration		X			X			
Check Fan Hub and Drive Pulley						X		
Check Hose Clamps on Air Intake Side	X					X		
Check Belt Conditions and Tensioner				X		X		
Check and/or Adjust Valve Clearance						X		
Check Water Pump		X				X		
Steam Clean Engine		X					X	
Clean Fuel System							X	
Check Alternator							X	
Check Starter Motor							X	
Check Vibration Damper								X
Check Cooling and CAC systems								X

**Figure 2-1-1 Maintenance Schedule
(Sheet 1 of 2)**

Operation Manual – ITW GSE 4400 Tier 3

Hourly Interval	AR	50-150	10	250	500	1000	1500	2000
Calendar Interval		Once	Daily	3 Mo.	6 Mo.	1 Yr.	1.5 Yr.	2 Yr.
Symbol	AR	BR	A	B	C	D	E	F
Engine (continued)								
Flush and Change Coolant								X
Drain & Inspect Fuel Tank	X					X		
Check Fan Mounting				Spring & Fall				
Clean Cooling System				Spring & Fall				
Check Hoses				Spring & Fall				
Clean Electrical Connections				Spring & Fall				
Check Thermostats and Seals				Fall				
Electrical (24 VDC System)								
Check All Lights			X					
Check Alternator Charging Rate			X					
Check Battery				X				
Clean Battery Terminals	X			X				
Check Wiring and Connections					X			
Check All Engine Meters			X					
Electrical (400-Hz System)								
Check E-F By-Pass Operation				X				
Check Output Cable and Connectors			X					
Check Volt, Amp & Frequency Displays			X					
Check and/or Adjust Output Voltage	X				X			
Inspect Wiring and Connectors					X			
Clean and Inspect Generally					X			

Note: “G” service (10,000+ hours) items are covered in section j) below.

**Figure 2-1-1 Maintenance Schedule
(Sheet 2 of 2)**

Operation Manual – ITW GSE 4400 Tier 3

3) Inspection/Checks

a) General

- 1) See Chapter 2-2 for detailed maintenance procedures.
- 2) See Chapter 2-3 for adjustment and test procedures.

b) “AR” Checks and Operations (As Required)

- 1) Engine
 - a) Change Air Cleaner
 - i. Replace the air filter when the “Air Filter Clogged” warning is displayed. These filters should not be washed because washing breaks down the material inside the filters.
 - ii. Check and tighten, as required, all coolant hose clamps, air intake hose clamps and exhaust clamps. Check all coolant hoses, air intake hoses and exhaust pipes for leaks.
 - b) Electrical System (24 VDC) – Check Battery Terminals
 - i. Periodically, open the battery compartment panel in the right cable tray and visually check the battery cable connectors and battery posts. If corrosion is observed, disconnect the cables and clean battery posts and connectors with a wire brush or special battery post-cleaning tool. Coat the posts and connectors with a light film of petroleum lubricant before reconnecting the cables.
 - c) Electrical (400 Hz System) -- Check Output Voltage
 - i. Check the output voltage and be sure it is set for 115 VAC \pm 1 V. Adjustment can be made using the Setup menu. (See Chapter 1-3, paragraph 4.1.)

c) “BR” Checks and Operations (Break-In Period, Once After 50-150 hrs.)

The following procedures are precautionary measures taken on most new engines. If a problem occurs with any of the following issues, be sure to recheck it after the next 50-150 hours.

- 1) Engine
 - a) Check for leaks and correct. This involves an overall inspection of the engine and may require some maintenance if leaks are found. Refer to the engine manufacturer's operations manual for assistance.
 - b) Change all fuel filter elements. Metal shavings from the new fuel tank can clog the filter.
 - c) Change crankcase oil. New engines often release metal shavings more frequently. Therefore, the crankcase oil must be changed as a precautionary measure.
 - d) Change oil filter element. The oil filter should be changed with the oil.
 - e) Check engine and generator mounts to ensure they are properly installed and they have not worked loose. (Torque is set at 100 N-m, 73.7 ft-lb.)
 - f) Check coolant additive concentration. Refer to the engine manufacturer's operations manual for assistance.
 - g) Steam clean the engine to free it of oil and dirt to prevent uneven engine cooling “hot spots”. The oil and dirt can also fall into the engine and fuel system when covers are removed during repair work.
 - h) Inspect the water pump weep hole for indication of a steady leak. If a steady flow of coolant or oil is observed, replace the water pump with a new or rebuilt unit. Refer to the engine manufacturer's operations manual for assistance.
-

Operation Manual – ITW GSE 4400 Tier 3

d) “A” Checks and Operations (10 Hours or Daily).

- 1) Engine.
 - a) Check Crankcase Oil Level.

CAUTION

DO NOT overfill. **DO NOT** operate the engine with oil level below the lower bar or above the upper bar on the dipstick.

- i. Check oil level daily with oil gauge dipstick.
 - ii. Oil level should not be checked until 3 to 5 minutes after engine shutdown. Keep oil level as near the upper bar as possible.
- b) Drain Fuel Lubricity Filter/Pre-Filter Element
- The life of the fuel pump and injectors can be extended if the operator drains about a cup of fuel from the fuel pre-filter element to remove water and sediment before starting the engine each day.

CAUTION

BE SURE to prime and bleed the fuel system after draining the filters, replacing filter element, or if the fuel tank has run empty. Failure to do so can cause engine-starting problems.

- i. Provide a container for catching drained fuel.
 - ii. Open the drain valve on the fuel/water filter by turning it counterclockwise.)
 - iii. Drain the filter until clear fuel is visible.
 - iv. Tighten the drain valve.
 - v. Safely dispose of drained fuel.
 - vi. Purge air from fuel system if necessary.
- c) Check Coolant Level
- i. Check coolant level daily or at each fuel fill interval. Investigate for cause of any coolant loss.

WARNING

Cooling system is pressurized. To avoid personal injury, **DO NOT** remove radiator cap when engine is hot.

- d) Check for Leaks and Correct
- At each daily start-up, check for coolant, fuel, and oil leaks. Coolant leaks may be more noticeable when components are cold. Observe pumps, hoses, fittings, gasket connections, etc., for signs of leakage. Correct as required.

Operation Manual – ITW GSE 4400 Tier 3



Figure 2-1-2 Fuel Lubricity Drain

- e) Check Fault Code Meter.

At each daily start-up, observe the fault screen on the display of the control panel. If the display shows “AIR FILTER CLOGGED”, change the air filter. See Chapter 2-4 for other fault codes.

- f) Check Exhaust System.

Visually inspect muffler and exhaust pipes for rust and signs of approaching failure. Listen for any gasket or joint leaks.

WARNING

A leaking and defective exhaust system could be a fire hazard.

- 2) Electrical System (24 VDC)

- a) Check All Lights.

Check all indicating lights to be sure they operate when they should. If any light fails to operate, check the indicator and insure proper power is being given. If power is present and the light does not activate, replace the light fixture.

- b) Check Engine Battery Voltage.

Observe the engine voltmeter each time the engine is started to be sure the alternator is functioning correctly and charging the batteries. If the batteries need to be replaced, be sure the replacements meet the specifications for Cold Cranking Amps (CCA) and Reserve Capacity.

- c) Check the operation of all the engine indicators.

Operation Manual – ITW GSE 4400 Tier 3

3) Electrical (400 Hz System).

a) Check Output Cables and Connector.

Check the output cable and plug connection for damaged insulation and contacts each time the connector is detached from the aircraft.

b) Monitoring sensors.

Verify that the voltage, amps and frequency readings are displaying correctly (use up and down arrows) each time the unit is started.

e) “B” Check and Operations (250 Hours or 3 Months).

1) Engine.

a) Prevent Diesel Engines Wet Stacking.

All diesel engines operated for extended periods under light load may develop a condition commonly referred to as wet-stacking. This condition results from the accumulation of unburned fuel in the exhaust system. It is recognizable by fuel oil wetness around the exhaust manifold, pipes, and muffler along with an excessive amount of soot.

Wet-stacking is common, and can be expected in diesel engines operated under light loads. Light loads do not allow the engine to reach the most efficient operating temperature for complete combustion of fuel and will also increase the fuel consumption rate. The unburned fuel collects in the exhaust system to create the wet condition known as wet-stacking.

To alleviate wet-stacking in lightly loaded engines, it is recommended that the machine be connected to a load bank after each 250 hours of use and operated under full rated load for one hour. This will burn away and evaporate the accumulation of fuel and soot in the exhaust system. This clean-out procedure should be considered as a regular maintenance operation for machines operated under light loads.

b) Charge-Air-Cooler and Piping.

- i. Inspect the charge-air-cooler for dirt and debris blocking the fins. Check for cracks, holes, or other damage.
- ii. Inspect the pipes and hoses for leaks, holes, cracks, or loose connections. Tighten the hose clamps if necessary.

c) Check and record oil pressure.

After each oil change, check and record oil pressure at operating speed after oil has warmed to approximately 140° F. Record oil pressure under identical conditions at each oil change interval. A comparison of pressure at idle speed with previous readings will give an indication of progressive wear of oil pump, bearings, shafts, etc. Investigate any abnormal change in pressure readings.

Operation Manual – ITW GSE 4400 Tier 3

- d) Check Radiator Core and Hoses.
 - i. Inspect the radiator core for dirt and debris blocking the fins. Clean as necessary. Check for cracks, holes, or other damage.
 - ii. Check Fuel Pump.
 - iii. Inspect the fuel injection pump mounting nuts for loose or damaged hardware. (2) Electrical (24 VDC system).

NOTE: The battery furnished with this generator set is MAINTENANCE FREE. Check battery terminals and clean if necessary.

- 2) Electrical (400 Hz System).
 - a) Check the operation of the E-F bypass system.

f) “C” Checks and Operations (500 Hours or 6 Months)

- 1) Engine.
 - a) Check Engine and Generator Mounts

CAUTION

An unstable or loosely mounted engine can create hazardous environment and may damage equipment.

- i. Engine mount bolts must be torqued to 100 N-m (73.7 ft-lb.).
- ii. Generator mount bolts must be torqued to 100 N-m (73.7 ft-lb.).
- b) Change oil and oil filters.
- c) Change all fuel filters.
- d) Check Coolant Additive Concentration.

The cooling system protective liquid (nitrite-, amine- and phosphate free) provides effective protection against corrosion, cavitation, and freezing. See engine manufacturer's operation manual for ordering and mixture details.

- 2) Electrical (24 VDC system).
 - a) Wiring.
 - i) Inspect all cables and leads for worn or damaged insulation.
 - b) Connections.
 - i) Inspect connectors for damaged or corroded condition.

3) Electrical (400 Hz System).

- a) Protective Monitoring Circuits.

Check operation of all protective monitoring circuits to make certain they will function if a fault occurs in the output circuit. Procedures for testing these circuits are contained in the Adjustment/Test section of this manual.

Operation Manual – ITW GSE 4400 Tier 3

- b) Inspect Wiring and Connections.

Check all cables, leads, and wiring for broken, worn and damaged insulation. Check all connections for tightness.

- c) Clean and inspect generally.

g) “D” Checks and Operations (1000 Hours or 1 Year)

- 1) Engine.

- a) Check Fan Hub and Drive Pulley.

Inspect for loose bolts or worn features. Tighten bolts and replace parts if necessary. Refer to the engine manufacturer’s operations and maintenance manual for assistance and the most update to date information.

- b) Check Hose Clamps on Air Intake Side.

Be sure that all clamps are properly secured to prevent leaks and all hose are in good condition.

- c) Check Belt Condition and Tensioner.

Refer to the engine manufacturer’s operations and maintenance manual for assistance and the most update to date information.

- d) Check and/or Adjust Valve Clearance.

Refer to the engine manufacturer’s operations and maintenance manual for assistance and the most update to date information.

- e) Check Water Pump.

Inspect the water pump weep hole for indication of a steady leak. If a steady flow of coolant or oil is observed, replace the water pump with a new or rebuilt unit. Refer to the engine manufacturer’s operations manual for assistance.

- f) Drain and Inspect Fuel Tank

Annually drain the fuel tank and inspect it for dirt, debris or Diesel fuel “algae”. Clean the tank if necessary. (See Chapter 2-2, section 5.f)

h) “E” Checks and Operations (1500 Hours or 1.5 Years)

- 1) Engine.

- a) Steam Clean Engine.

There are several reasons why the engine exterior should be kept clean. Dirt on the outside will enter fuel and oil filter cases and rocker housings when covers are removed, unless dirt is removed first. A clean engine will run cooler and develop fewer hot-spots. Steam cleaning is one of the most satisfactory methods of cleaning and engine; however, there are some **CAUTIONS** to be observed.

WARNING

Exercise care to avoid injury and damage to eyes and skin

Operation Manual – ITW GSE 4400 Tier 3

CAUTION

1. If a cleaning compound is used, select one that is free from acid and will not remove paint.
2. Protect (or remove) all electrical accessories, such as voltage regulator, alternator, and electrical wiring.
3. Seal all openings. **DO NOT** use a flammable solvent.
4. **DO NOT** use mineral spirits or solvents on a hot engine.
5. Remove or protect bottom panel of unit (belly pan) to protect insulation.

b) Clean Fuel System.

See engine manufacturer's operation manual for instructions.

c) Check Alternator and Cranking Motor.

The alternator and cranking motor on this engine require no periodic lubrication.

i) "F" Checks and Operations (2000 Hours or 2 Years).

1) Engine.

a) Check Vibration Damper.

Check vibration damper for looseness, wobble, chunking and streaking. Also verify the hub bolts are tightened to the engine manufacturer's specifications.

Refer to the engine manufacturer's operations and maintenance manual for assistance and the most update to date information.

b) Check Charge-Air-Cooler and Radiator Systems.

i. Check for damaged hoses and loose or damaged hose clamps.

ii. Check the radiator for leaks, damage, and build-up of dirt in the fins. Clean or replace as necessary.

c) Flush cooling system and change coolant.

Operation Manual – ITW GSE 4400 Tier 3

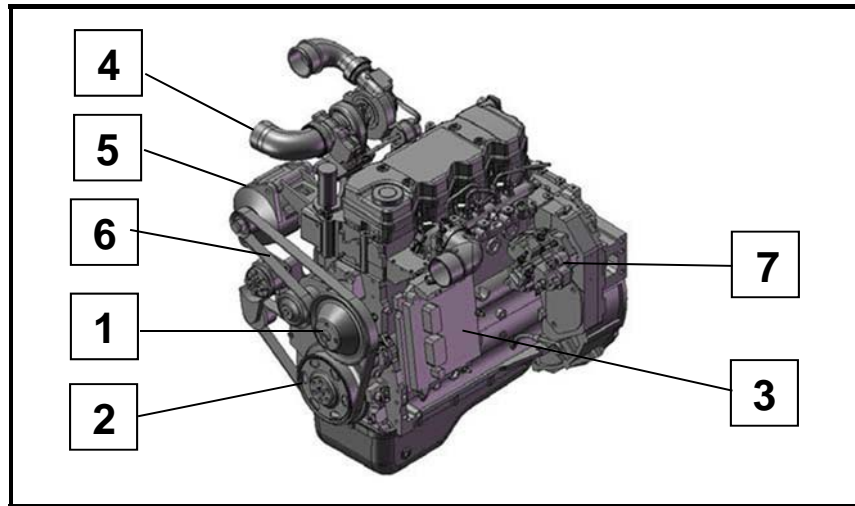

- | | |
|--------------------------------|-------------------|
| 1. Fan Pulley | 5. Alternator |
| 2. Vibration Damper | 6. Belt Tensioner |
| 3. Engine Control Module (ECM) | 7. Fuel Pump |
| 4. Exhaust Outlet | |

Figure 2-1-3 Engine Accessories

j) “G” Checks and Operations (Over 10,000 Hours).

- 1) Engine.
 - a. Refer to Engine OEM Service Center for recommended testing and maintenance.
- 2) Engine/ Generator Assembly

Note: All Generator Overhaul items to be performed by a qualified generator/ motor facility

 - a. Replace Generator Bearings
 - b. Inspect Front and Rear Bearing Housings
 - c. Inspect Generator Shaft for Wear
 - i. Replace Rotor Assembly if required.
 - d. Replace engine and generator shock mounts.

Operation Manual – ITW GSE 4400 Tier 3

k) Seasonal Maintenance Checks Spring/Fall (Engine).

- 3) Check Fan Mounting.
 - a) Check fan to be sure it is securely mounted.
 - b) Check for fan wobble and/or broken/cracked blades.
 - c) Check fan hub and crankshaft pulley for secure mounting. (2) Check cooling system each spring and fall. Clean if necessary. (3) Check All Hoses.
- 4) In addition to daily checks of hoses for leaks, inspect hoses thoroughly each time the cooling system is cleaned and serviced.
 - a) Inspect for signs of deterioration and collapse. Inspect for cracks and cuts. Inspect for cutting and deformation caused by hose clamps. Replace hoses as required.
- 5) Check thermostat and seals each fall when cooling system is serviced.

l) Lamps and Fuses:

- 1) Check all lamps daily.
- 2) Check fuses as required.
- 3) The fuse chart lists all fuses with their location, size, and type.

Item Protected	Location	Schematic Identifier	Type	ITW PART NO.
Display Board	Interface Board	F1	2A	AP-SI2076
Control Board	Interface Board	F2	5A	AP-SI2075
Exciter Circuit (24V)	Interface Board	F3	5A	AP-SI2075
Contactors	Interface Board	F4	5A	AP-SI2075
Relays	Interface Board	F5	2A	AP-SI2076
Key Switch	Interface Board	F6	5A	AP-SI2075
ECM Dongle	Interface Board	F7	5A	AP-SI2075
Exciter Circuit (180 V)	Interface Board	F8	500V, 6.3A	AP-SI2082
ECM	Interface Board	F9	20A	AP-SI2083
Engine Air Intake Heater	Engine Electrical Panel	F10	AMG-150	FU11370

Figure 2-1-4 Fuse Identification Chart

Operation Manual – ITW GSE 4400 Tier 3

Section 2 Maintenance Procedures

1) General

A suggested maintenance schedule is provided in Section 1 of this Servicing Chapter. Each step of the schedule is also covered in general in Section 1. This Section covers maintenance in more detail, where necessary.

Item	Maintenance Required
Engine Oil	Check oil level daily or after every 10 hours of use. Change oil and the oil filter after the first 50 to 150 hours of use, then at 500 hours or 6 month intervals thereafter. Engine oil capacity is approximately 11.6 quarts (11 liters).
Fuel/water Pre-Filter	Drain filters daily. Change the filter elements every 500 hours or after 6 months of use, whichever comes first.
Coolant	Check coolant level daily. Service and maintain coolant system according to Section 2-2, paragraph 6. Engine coolant capacity is approximately 20 quarts (18.9 liters)
Coolant hoses and connections	Check coolant hoses and connections daily for leaks.
Air Cleaner	Change air cleaner filter as required when the fault code display on engine control panel shows the "Air" code.
Fan Belt	Check fan belt condition and tension every 1000 hours or 1 year of use.
Alternator	Alternator bearings are sealed and require no periodic lubrication.
Starter	Starter motor bearings are sealed and require no periodic lubrication.
Water Pump	The water pump is packed at assembly and requires no periodic lubrication.
Fan Hub	The fan hub is lubricated at assembly and requires no periodic lubrication.
AC Generator	Periodic cleaning – no lubrication or adjustment required
Generator Controls	No periodic maintenance is required. Adjustments are covered in Section 2-3.
Trailer	Annually grease the wheel bearings.

Figure 2-2-1: Lubrication and Maintenance Chart

WARNING

STOP all operations at once if a serious or dangerous fault is discovered.

Operation Manual – ITW GSE 4400 Tier 3

2) Lubrication

a) General

Proper lubrication is one of the most important steps in good maintenance procedure. Proper lubrication means the use of correct lubricants and adherence to a proper time schedule. Lubrication points, frequency of lubrication, recommended lubricants and filters are indicated in Figures 2-2-1 and 2-2-2.

This section incorporates the engine maker's, engine lubrication recommendations from their Operation and Maintenance Manual.

b) Lubrication schedule

Time schedules indicated on the Maintenance Schedule, Figure 2-2-1, are approximate and based on average operating conditions. It may be necessary to lubricate more frequently under severe operating conditions such as: low engine temperatures, high oil temperatures, or intermittent operation. However, time intervals should not exceed those indicated in the chart without careful evaluation.

c) Oil specification

The engine lubricating oil that is recommended by the engine manufacturer is identified by an API (American Petroleum Institute) classification designation. The manufacturer does not recommend any specific brand of lubricating oil.

The use of quality lubricating oil, combined with appropriate lubricating oil drain and filter change intervals, are important factors in extending engine life.

Oil Type	Use oil specification API CF-4, HT/HS Viscosity 3.7cP minimum. Oil recommended for the diesel engines in this application is API Class CCMC. Refer to the manufacturer's operation manual.	
Capacity	Approximately 11.6 quarts (11 liters)	
Oil Filter Replacement Part Number	ITW GSE: 286897-029 Cummins: LF3970	
Lube Oil Viscosity Required as per Ambient Temperatures	<u>VISCOSITY</u> SAE 15W40 (Preferred) SAE 10W30 SAE 5W30 SAE 0W30	<u>AMBIENT TEMPERATURE CONDITIONS</u> 0°F (-18°C) and above for most climates -10°F to +50°F (-23°C to +10°C) Winter conditions -20°F to +50°F (-29°C to +10°C) Arctic Conditions -20°F and below to +50°F (-29°C and Below to +10°C)
Synthetic Oils	See the engine manufacturer's operations manual for usable synthetic oils and instructions.	

Figure 2-2-2: Lubrication Specifications

Operation Manual – ITW GSE 4400 Tier 3

d) Changing engine oil

Change the oil once after the first 50 - 150 hours of use and then every 500 hours of engine operation thereafter. The generator set is equipped with an hour meter to record actual engine operating time.

The ideal time to change engine oil is soon after a power delivery run, when the engine is at operating temperature. If lubricating oil is drained immediately after the unit has been run for some time, most of the sediment will be in suspension and will drain readily.

Change the oil filter element each time the oil is changed.

CAUTION

- High ash oils may produce harmful deposits on valves that can cause valve burning.
- Do not use solvents as flushing oils in running engines.
- Always use clean containers, funnels, etc.

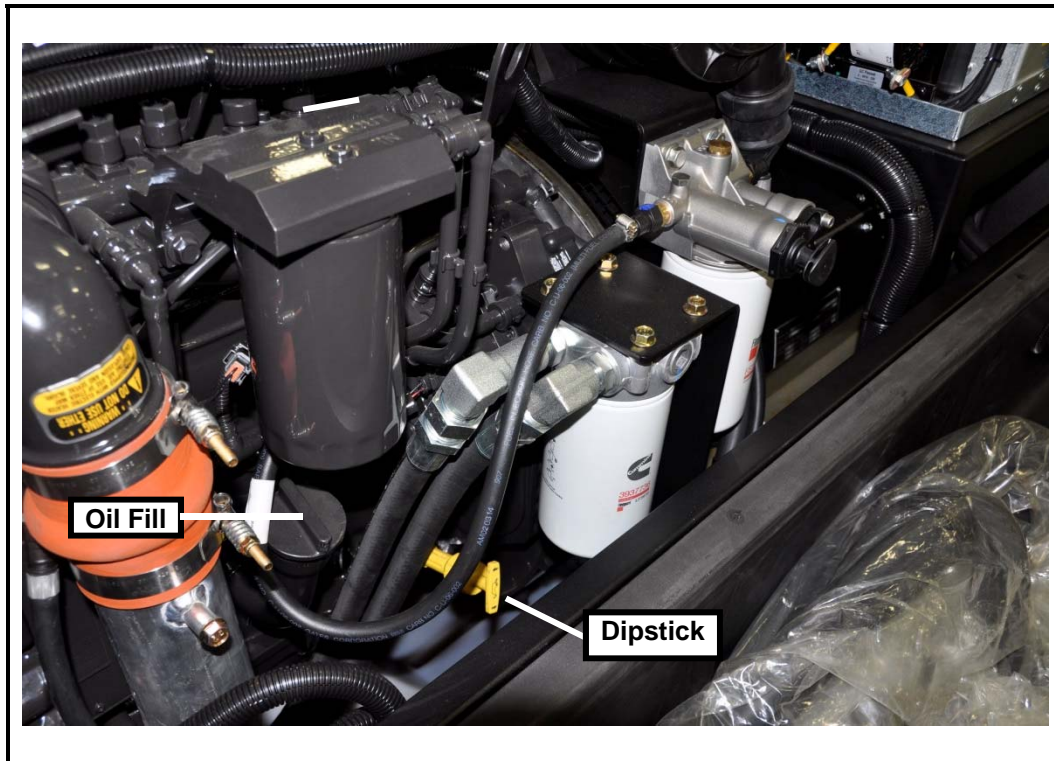

Figure 2-2-3: Oil Fill and Check Locations

Operation Manual – ITW GSE 4400 Tier 3

Change oil as follows:

- 1) Provide an open container for catching the old oil below the oil drain plug. Container capacity must be greater than 30 quarts (28.4 liters).
- 2) The oil drain tube can be found by the muffler at the front of the unit.
- 3) Remove the drain cap (older models or turn the valve handle.
- 4) While oil is draining, change the oil filter element. See instructions below.
- 5) Provide a container for catching spilled oil from the filter.
- 6) Remove the oil filter by turning it and inspecting it.
- 7) NOTE: The gasket can stick to the filter head. Make sure it is removed before installing a new filter.
- 8) Fill the new filter with clean lubricating oil before installation.
- 9) Apply a light coating of lubricating oil to the gasket-sealing surface and install the filter. DO NOT over tighten the filter.
- 10) Clean the drain cap and install when engine oil has completely drained or close the drain valve.
- 11) Refill the engine with new, clean oil that meets engine manufacturer's recommendations. Use the oil fill tube by the filter or the oil fill opening at the top of the engine.



counter-clockwise

CAUTION

Remember to close the drain cap and install the new oil before starting the engine.

- 12) Start engine and check oil pressure at once. Allow engine to run for 5 minutes, check for leaks then stop the engine.
- 13) After the engine has been stopped for about 5 minutes, recheck the oil level. Add oil, if required, to bring the level up to the high bar on the oil dipstick.

CAUTION

If bearing metal particles are found on the element or in the shell, the source should be determined before a failure.

WARNING

STOP operations at once, if a serious or possibly dangerous fault is discovered.

Operation Manual – ITW GSE 4400 Tier 3

e) Engine Accessories Lubrication

1) Alternator

Most alternators contain sealed bearings and require no periodic lubrication, however, check to make certain there are no lubrication points on your particular alternator.

2) Starter

Most starting motors are lubricated at assembly and should be re-lubricated only when the starter is removed and disassembled, however, inspect the starter to make certain it has no lubrication points.

3) Water Pump

The water pump is packed at assembly and requires no periodic lubrication. Replace pump if signs of lubricant leakage are found.

4) Fan Pulley

The fan hub is also lubricated at assembly and requires no periodic lubrication. Replace hub if lubricant is leaking.

f) Trailer Lubrication

1) Wheel bearings

Inspect each wheel bearing annually to ensure that there is sufficient grease in the assembly.

2) Fifth Wheel Hub Bearings

Inspect the Fifth Wheel Hub bearing every three years to ensure that there is sufficient grease in the assembly.

Paragraph	Name	Specification	Notes
d)	Grease, General Purpose	MIL-G-3545	Excludes those of sodium or soda soap thickness.
e)	Grease, Wheel Bearing	ASTM D-4950	NLGI #2 Grade Lithium Complex EP Grease

Operation Manual – ITW GSE 4400 Tier 3

3) Servicing the Air Cleaner

A definite time schedule for cleaning or changing the air cleaner cannot be determined because of varying operating conditions. Pull the yellow tab out (about 1 inch) then rotate the hub counterclockwise about one inch and pull it off of the housing to access the air cleaner filter. It may be inspected either at prescribed service intervals or at any time deemed necessary.

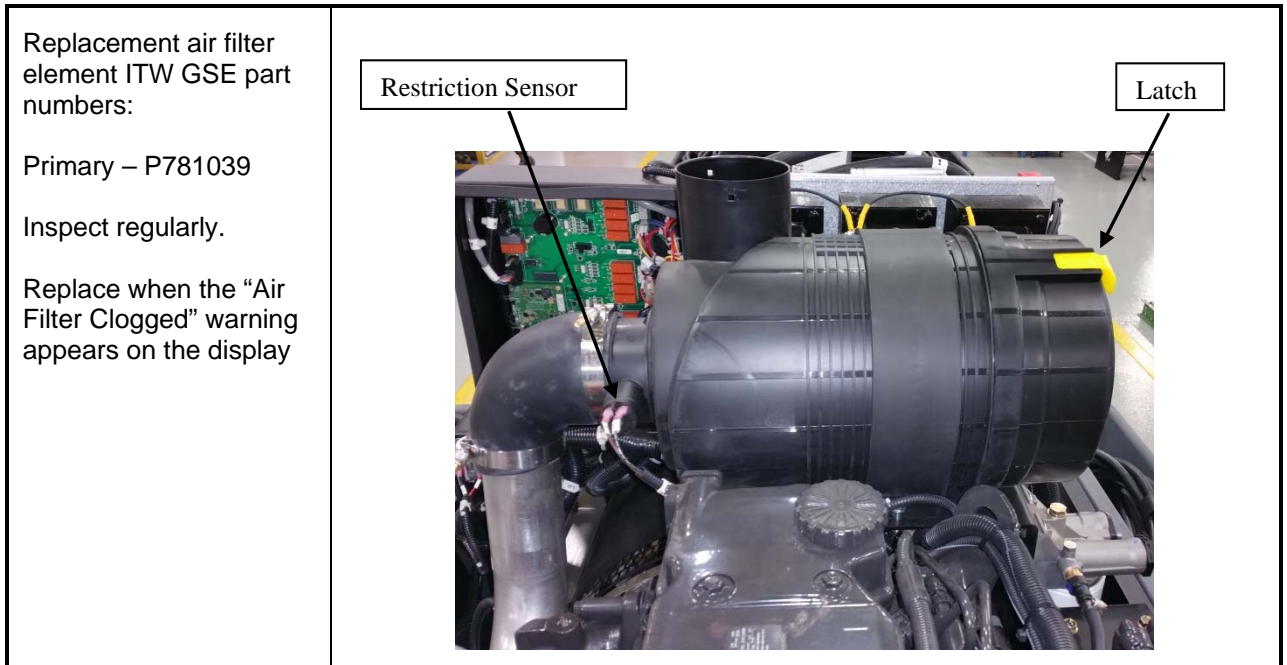

Figure 2-2-4: Air Cleaner Assembly

a) Inspecting the Air Cleaner

- 1) Make periodic checks of air cleaner inlet screen for obstructions. If any obstructions are present, remove them.
- 2) Check outlet connection for proper seal.

b) Changing the Air Filter

- 1) Pull out the latch and rotate the back cover to the unlocked position (counterclockwise as viewed from the rear). The cover has padlock symbols to show the locked and unlocked positions.
- 2) Remove the end cover of housing.
- 3) Pull out air filter elements and replace.
- 4) Replace end cover on housing, making certain that the filter is centered in the housing.
- 5) Replace the end cover and rotate it to the locking position.
- 6) Push the yellow latch back in to lock the cover.

c) Disposal

Normal trash pick-up should be acceptable. **NEVER** burn the air filter for disposal.

Operation Manual – ITW GSE 4400 Tier 3

4) Engine Fuel

a) How to select Fuel—Quality

The quality of fuel oil used in the diesel engine is a major factor in engine performance and life. Fuel oil must be clean, completely distilled, stable and non-corrosive.

CAUTION

Due to the precise tolerances of diesel injection systems, it is extremely important that the fuel be kept clean and free of dirt or water. Dirt or water in the system can cause severe damage to both the injection pump and the injection nozzles.

CAUTION

The use of low lubricity fuels can shorten life and/or damage the engine's fuel pump. The engine manufacturer recommends only diesel fuel.

Use commercially available diesel fuel with less than 0.5% sulfur content. If the sulfur content is higher than 0.5%, oil change intervals should be reduced (See engine manufacturer's operation manual).

In general, fuels meeting the properties of ASTM designation D 975 (grades 1-D and 2-D) have provided satisfactory performance. For more information regarding the selection of fuel to use, refer to publication "Engine Requirements—Lubricating Oil, Fuel, and Filters" available from authorized engine maker's service outlets.

b) Cold Weather Operation

In cold weather, diesel fuel will form wax crystals, which can restrict flow and clog filters. Fuel oil suppliers approach this problem several ways. Some provide a specially refined product, while others may use flow-improving additives or winter blends. Winter blended fuel will likely contain kerosene or 1-D fuel, which provide good cloud point temperatures, but result in a lighter fuel with a lower heat content. These fuels may be used, but they may result in reduced engine power and/or increased fuel consumption.

In most cases, adequate resistance to cold can be obtained by adding an additive. For further assistance contact the nearest engine manufacturer's service representative.

Operation Manual – ITW GSE 4400 Tier 3

5) Engine Fuel System

The fuel system consists of five primary components: fuel tank, lubricity filter, primary fuel filter, fuel lift pump, and the fuel return line. The following are maintenance procedures for each of these items.

a) Fuel Tank

Be sure that no foreign objects are permitted in the fuel tank. The fuel tank must be removed and flushed out if objects are found in the Fuel Water Separator or Lubricity Additive Filter.

b) Fuel Water Separator or Lubricity Additive Filter

A lubricity fuel filter, which is also a fuel/water separator, is mounted in the generator compartment above the fuel tank outlet. The filter's function is to add a lubricant to the fuel to help prolong the engine seals and fuel pump life when fuels other than diesel are used (i.e., jet fuel). The filter also removes foreign material and removes both free and emulsified water from the fuel before it enters the fuel lift pump. Daily draining of the filter is required.

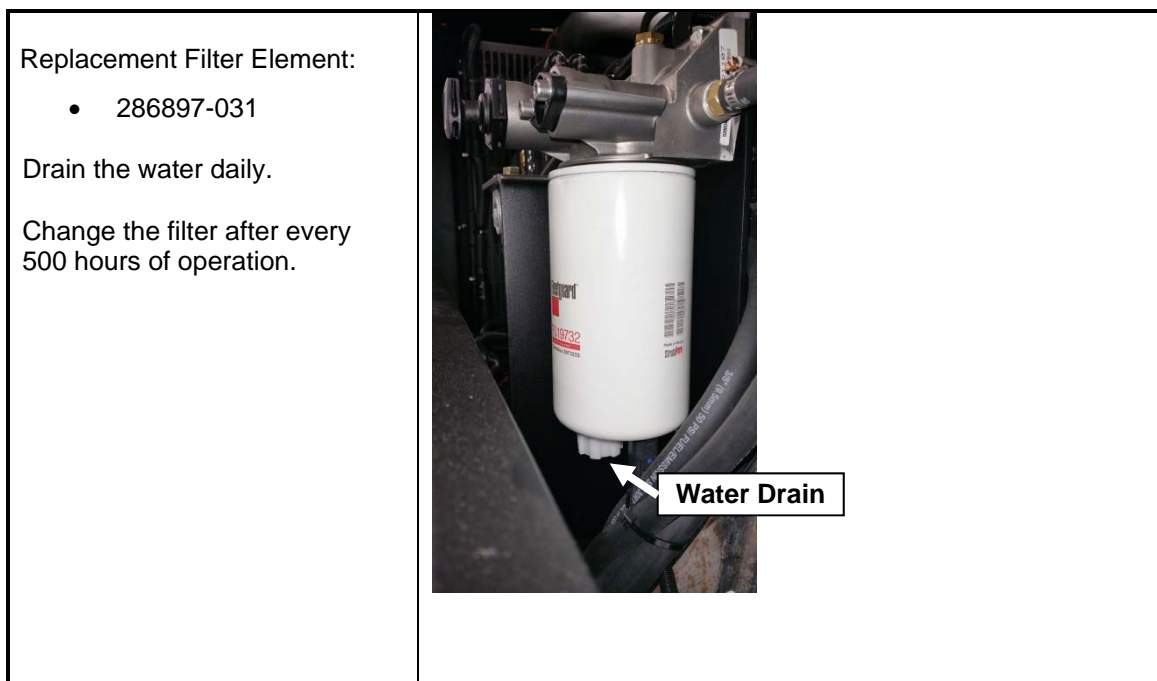

Figure 2-2-5: Lubricity Filter

1) To drain the water:

- Open drain valve.
- Drain accumulated water and contaminants.
- Close drain valve.

The lubricity filter must be changed every 500 hours of operation for the fuel filter to continue adding the proper amounts of the lubricity additive into the fuel system.

Operation Manual – ITW GSE 4400 Tier 3

2) To change the lubricity filter:

CAUTION

When installing new element, do not over tighten it; mechanical tools may distort or crack filter head.

- a) Place a pan underneath the fuel filter to catch spilled fuel.
- b) Shut off fuel valve.
- c) Drain off some fuel by opening the drain valve.
- d) Undo fuel filter with commercial tool and spin off.
- e) Clean any dirt from the filter carrier rim
- f) Apply a light film of oil or diesel on the rubber seal on the new filter.
- g) Fill new filter with diesel fuel.
- h) Screw in the new fuel filter “snug”.
- i) Check that the cartridge is seated correctly against the gasket and tighten with a final half turn.
- j) Make sure that all rags, or absorbent sheets, are clear of moving engine parts and cannot be drawn in to the radiator fan.
- k) Open fuel valve.
- l) Start the engine and check for leaks. Correct as necessary with the engine off.

c) Primary Fuel Filter

A primary fuel filter is mounted above the engine starter in the engine compartment. The filter’s function is to remove foreign material from the fuel before it enters the fuel lift pump.

Replacement fuel filter part number:

- 286897-036

Change the fuel filter after every 500 hours of operation.



Figure 2-2-6: Primary Fuel Filter

Operation Manual – ITW GSE 4400 Tier 3

1) To change the fuel filter:

- a) Shut off fuel valve.
- b) Place a pan underneath the fuel filter to catch spilled fuel.
- c) Undo fuel filter with commercial tool and spin off.
- d) Catch any fuel.
- e) Clean any dirt from the filter carrier rim
- f) Apply a light film of oil or diesel on the rubber seal on the new filter.

CAUTION

When installing new element, do not over tighten it; mechanical tools may distort or crack filter head.

CAUTION

Make sure that all rags, or absorbent sheets, are clear of moving engine parts and cannot be drawn in to the radiator fan.

- g) Fill new filter with diesel fuel. Screw in the new fuel filter “snug”. Check that the cartridge is seated correctly against the gasket and tighten with a final half turn.
- h) Open fuel valve.

d) Fuel Pump

The fuel pump supplies high pressure to the fuel system so the diesel fuel can circulate freely. This engine is equipped with a common rail fuel system that is under very high pressure. **DO NOT** attempt to crack fuel lines.

WARNING

DO NOT attempt to crack fuel lines. This engine is equipped with a common rail fuel system that is under very high pressure. Failure to follow this guideline could result in injury or death.

e) Fuel Return

The fuel return is a fuel line (tube) that takes unused fuel from the engine, and delivers it to the fuel tank. No maintenance is required.

f) Fuel Level Indicators

There are two fuel level indicators in the unit; a mechanical dial indicator on the back of the unit that is only accurate when the fuel tank is above 50% full and is for the use of the refueler, and an electronic sensor in the fuel tank that is used to display the actual fuel level on the operator's screen.

Operation Manual – ITW GSE 4400 Tier 3

g) Draining the Fuel Tank

- 1) The fuel tank should be drained and cleaned out annually, when the various fuel filters start to become excessively fouled and before storing the unit for long periods of time.
- 2) Before draining the fuel tank, we recommend pumping at least 90% of the fuel out of the tank (use the operator display to determine the amount of fuel remaining). The fuel tank has two 1/8" NPT fittings with thread sealant on them that are accessible under the trailer, once it is lifted up. (Use a 7/16" wrench or socket to remove the fitting.)



- 3) Once the tank is fully drained, verify that there is no debris in the bottom of the tank on either side. If any dirt, material or build up exists inside the tank, flush with diesel fluid to remove the foreign material.
- 4) Use the following procedure to re-install the fittings:
 - a) The proper method of assembling tapered threaded connectors is to assemble them finger tight, then wrench tighten to the specified number of turns from finger tight. The following assembly procedure is recommended to minimize the risk of leakage and/or damage to components.
 - i. Inspect components to ensure that male and female port threads and sealing surfaces are free of burrs, nicks and scratches, or any foreign material.
 - ii. Apply sealant/lubricant to male pipe threads if not pre-applied.
 - b) With any sealant, the first one to two threads should be left uncovered to avoid system contamination. If PTFE tape is used it should be wrapped 1-1/2 to 2 turns in clockwise direction when viewed from the pipe thread end. (Caution: More than two turns of tape may cause distortion or cracking of the port.)
 - c) Screw the connector into the port to the finger tight position.
 - d) Wrench tighten the connector to 1.5 - 3 turns past finger tight. Never back off (loosen) pipe threaded connectors to achieve alignment.
 - e) If leakage persists after following the above steps, check for damaged threads and total number of threads engaged.
 - f) If threads on the fitting are badly nicked or galled, replace the fitting. If port threads are damaged, re-tap, if possible, or replace the component. If the port is cracked, replace the component.
 - g) Normally, the total number of tapered threads engaged should be between 3-1/2 and 6. Any number outside of this range may indicate either under or over tightening of the joint or out of tolerance threads. If the joint is under tightened, tighten it further but no more than one full turn. If it is over tightened, check both threads, and replace the part which has out-of-tolerance threads.

Operation Manual – ITW GSE 4400 Tier 3

6) Engine Cooling System

a) General

Cooling system service requires more than maintaining the proper coolant level in the radiator and protecting the system against freezing. Water should be clean and free of any corrosive chemicals such as chloride, sulfate, and acids. It should be kept slightly alkaline with a pH value in the range of 8.0 to 9.5. Any water, which is suitable for drinking, can be used in the engine when properly treated as described in engine maker's operation manual. The engine maker's representative should be consulted regarding the selection of satisfactory brand, permanent-type antifreeze for use in the cooling system.

b) Radiator Cap

1) General

A pressure relief valve is built into the radiator cap. It is designed to open at a pressure of approximately 15 psi (103.4 Kpa).

WARNING

When removing cap from a very hot radiator, **DO NOT** turn cap past safety stop until the pressure or steam has escaped.

2) Removal

To remove, turn the cap to the left (counterclockwise) to the safety stop. When all pressure is released, press down on the cap and continue to turn until the cap is free to be removed.

CAUTION

Allow engine to cool before adding coolant.

CAUTION

Do not attempt to repair the valve in a radiator cap in case of failure. Replace with a new cap.

3) Installation

When installing the cap, be sure it is turned clockwise as far as it will go so that the pressure retaining valve will be functional.

c) Coolant

The preparation and maintenance of the coolant solution is important to engine life and is completely covered in the engine manufacturer's operation manual. For information regarding coolant specifications, testing equipment, antifreeze, etc., refer to engine maker's operation manual that accompanies the equipment's manual or consult the local engine maker's representative.

Operation Manual – ITW GSE 4400 Tier 3

CAUTION

Never use soluble oil in the cooling system.

1) General.

A permanent type antifreeze is recommended for use in the cooling system.

CAUTION

1. **DO NOT** use methanol or alcohol as antifreeze.

2. **DO NOT** mix brands or type of antifreeze. A solution containing two or more types of antifreeze is impossible to test accurately.

2) Selecting antifreeze.

a) Select a permanent type antifreeze known to be satisfactory for use with chromate corrosion resistor.

b) When it is not known if the antifreeze is satisfactory for use with chromate resistor, check with local engine manufacturer's representative for a list of compatible antifreezes.

(3) Checking antifreeze solution.

Check the solution with a reliable tester when in doubt about antifreeze protection.

d) Draining the Cooling System

To completely empty the cooling system requires draining the radiator assembly. Follow these steps to drain the cooling system:

1) Remove radiator cap.

2) Place a drain pan with at least a 40 quarts (28.4 liters) capacity under radiator to catch coolant.

3) Remove the front grill to access the hose & valve. Place the drain hose into the drain pan.

4) Open the radiator drain valve.

5) Allow the system to drain completely.

NOTE: Be sure the drain valve doesn't clog during draining.

6) When the system is completely drained, close the drain valve and coil the hose back up.

7) Replace the front canopy cover.



e) Flushing the Cooling System

Flushing the cooling system should be a yearly maintenance procedure. By flushing the system, clean water is forced through the engine block to remove expired coolant and other contaminants.

Operation Manual – ITW GSE 4400 Tier 3

f) Cleaning the Radiator Core

Blow out accumulated dirt from the radiator core air passages, using water. Bent or clogged radiator fins often cause engine overheating. When straightening bent fins, be careful not to damage the tubes or to break the bond between fins and tubes.

NOTE: Direct the water in a reverse direction to normal air flow. Normal flow on this installation is from the engine compartment out ward.

g) Filling the Cooling System

The preparation and monitoring of coolant in liquid-cooled engines is especially important because corrosion, cavitation, and freezing can lead to engine damage. For coolant system protection details see the engine manufacturer's operations manual.

1) Install coolant

- a) Remove radiator cap. Be sure the radiator drain valve is closed (Front panel must be removed to access this location).
- b) Pour coolant into radiator very slowly until it reaches the bottom of fill neck. Allow time for trapped air to escape from the system then continue filling until the coolant level remains at the bottom of the fill neck.
- c) Start the engine and bring up to rated speed and allow the thermostat to open. Add coolant as trapped air escapes from the system and the coolant level falls.
- d) Continue to check coolant level until all trapped air escapes. Add coolant if needed to fill to the bottom of fill neck. Install radiator cap.

2) Inspection/Check

- a) Check system for evidence of leaks.
- b) Inspect all hoses. Install new hoses as necessary. Tighten hose clamps as required.
- c) Check the condition of fan and water pump belts. Replace belts if necessary.

NOTE: It is good practice to attach a card, indicating the cooling system contents and date serviced, to the radiator filler neck.

h) Thermostat

The thermostat should be checked each fall, or as required. Refer to engine manufacturer's operations manual for recommended instructions.

Operation Manual – ITW GSE 4400 Tier 3

7) Engine Drive Belt

a) General

The engine cooling fan, alternator, and water pumps are driven by one serpentine belt, which must be replaced if worn or damaged.

b) Preparation for Belt Check and Adjustment

All driven assemblies must be securely mounted in operating position before checking belt tension.

c) Checking Belt Tension

WARNING

DO NOT Check belt tension with engine running

Check belt tension every 1000 hours, or once year, whichever comes first. A belt that is too tight is destructive to bearings of the driven part. A loose belt will slip and cause inefficient operation of the part being driven as well as wear to the belt.

CAUTION

Inspect and replace the belt if it has unacceptable cracks, is frayed, or has pieces of material missing.

Belt tension may be checked by manually depressing the belt with an index finger to determine the amount of belt deflection obtained. When a force is applied at a point halfway between pulleys on the longest span of a belt, there should be no more than 1/2 inch of deflection attained. Refer to the engine manufacturer's operation manual for checking belt tension and changing worn belts.

8) Generator Maintenance

The 400 Hz generator requires no maintenance or service other than periodic cleaning. The unit is brushless and has bearings that are permanently lubricated and sealed.

a) Cleaning

The generator may be cleaned by careful use of compressed air and/or a good, SAFE commercial cleaner. Steam cleaning of the generator is not recommended because the use of steam and harsh chemical compounds may result in damage to insulation and other generator components.

WARNING

Never use solvents as this is a fire hazard

b) Adjustment

The generator itself requires no adjustment. Adjustment procedures for generator controls are covered in Section 2-3.

Operation Manual – ITW GSE 4400 Tier 3

9) Replacing the Control Board Battery

Before removing the Control Board and to avoid any static discharge to the Control Board during the replacement of the battery, please take ESD (Electro Static Discharge) precautions.

*** Important Note!**



Before you remove the battery from the holder, make sure that the replacement battery is within reach, as the **Control Board must not be without battery power for more than 30 seconds.**

Otherwise, all software and the setup data will be erased. *

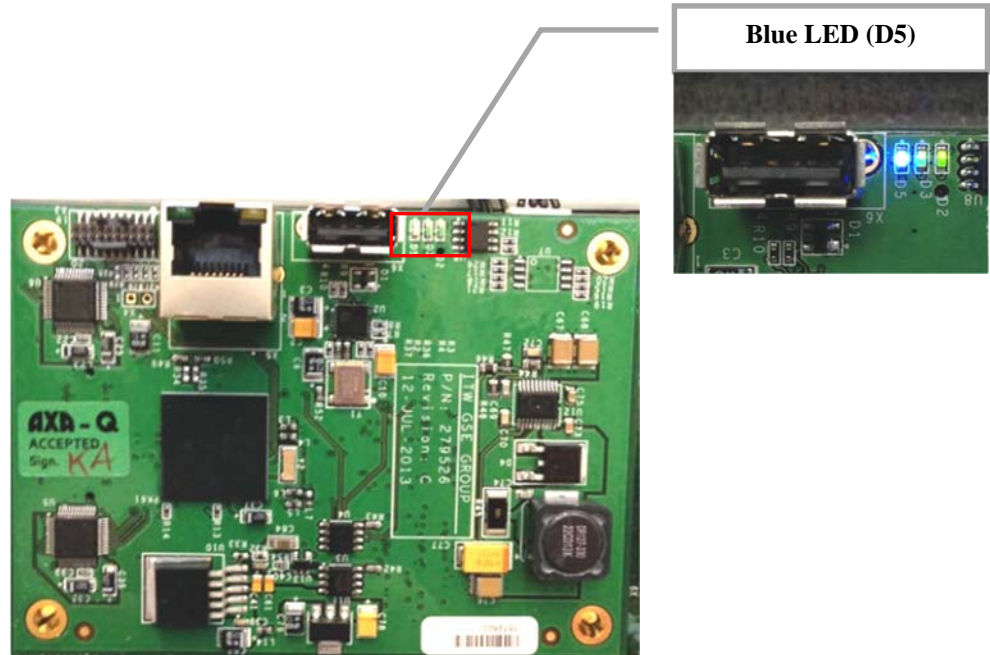



Fig. 8.2.3 Control Board (front view)

To replace the battery, **Switch OFF** the unit by means of Q1. Remove the Control Board from its 4 posts marked with a  in Figure 8.2.3. Place the PCB on an insulated surface, with the back side face up.

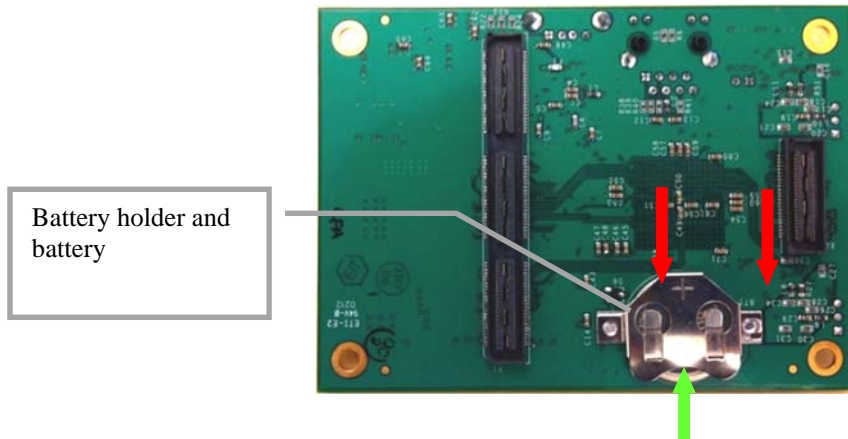

Fig. 8.2.4 Control Board (rear view)

Operation Manual – ITW GSE 4400 Tier 3

Remove the battery from the holder using a small **insulated** screwdriver to push out the battery, direction indicated by the two red arrows on Figure 8.2.4 and insert the new battery in the direction of the single green arrow on Figure 8.2.4.

Mount the control board on the interface board again by gently pressing the PCB to its rest on the Interface Board. Make sure that all 4 corners are fully pressed towards the Interface Board.

Switch on the unit via the input switch Q1 and close the door. The unit now passes through the initialization test and goes into standby mode.

Enter the setup menu and select menu item "Battery Replaced" to confirm new battery installation.

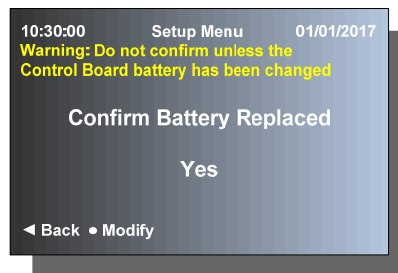

* Important Note!

If the blue LED on the Control Board (location can be found on the Fig. 8.2.3) flashes with approximate 2 flashes per second and the display reports "Communication Error", the firmware on the Control Board has been erased. The Control Board must be sent to ITW GSE to be reloaded.



To ensure high reliability of the back-up battery, the only type of battery that can be used on the Control Board is the Panasonic BR-2032

Operation Manual – ITW GSE 4400 Tier 3

Section 3 Adjustment/Test

1) General

These adjustments and test procedures are applicable to testing and adjusting the generator set after major repair, major parts replacements, or overhaul.

IMPORTANT

To perform most of the following tests, a load bank with an EF interlock circuit is required. If an EF interlock is not available on a load bank, see special procedure in the EF Bypass section (Chapter 1-3 paragraph 4.4) for disabling the EF circuit.

2) Testing the 400 Hz Generator Set

a) Pre-operational Test Procedures

- 1) Check engine oil level. Oil should be at high bar on the dipstick.
- 2) Check radiator coolant level, if not full then fill with appropriate climate mix of ethylene glycol and water. Total capacity is 20 quarts.
- 3) Check tension of drive belt.
- 4) Verify that there is at least a 1/4 tank of diesel fuel.
- 5) Make a general inspection of all wiring, and terminals. Inspect the equipment to be certain no damage will result from starting the engine.
- 6) Turn on battery disconnect switch.
- 7) Place unit in 'Engine Only' Diagnostic Mode. (See Menu Operating Instructions, Chapter 1-3 Paragraph 4.19) Return to home screen to view status. (Screen will display Generator Diagnostics.)

b) Engine Test Procedures

- 1) Press engine button to start engine. Engine should start and ramp up to idle speed, 1800 RPM (± 5).
- 2) Check for coolant, fuel and oil leaks. Listen for air leaks and other engine issues.
- 3) Verify display voltage is over 27 VDC. (Battery is charging.)
 - a. Voltage _____ VDC
- 4) Press Output button (any Output) to make engine go to rated speed, 2000 RPM (± 5). (Output will not function.)
- 5) Check for coolant, fuel and oil leaks. Listen for air leaks and other engine issues.
- 6) Press engine button to shut down unit.

Operation Manual – ITW GSE 4400 Tier 3

c) 400Hz Initial Testing and Setup:

- 1) Connect Output cable(s) to the appropriate load bank(s) with interlock enabled (as required)
- 2) Press engine button to start engine. Engine should go straight to rated speed.
- 3) Verify Output frequency on power analyzer. (400Hz, ± 2 Hz)
Measured Frequency: _____ Hz
- 4) Verify Output voltage, line to N.
- 5) MEASURED Voltage A _____ VAC B _____ VAC C _____ VAC
- 6) Check PWM Duty Cycle reads 20%. (± 5 %)
Duty Cycle _____ %

d) Output 1 Verification:

- 1) Make sure that the EF switch is in the ON position on the load bank and turn on Output 1. Contactor must close and indicator on the display panel illuminate.
- 2) Verify 'ABC' phase rotation at the load bank.
- 3) Turn the EF switch OFF on the load bank and verify that contactor opens and fault is displayed. Red lamp on display should flash.
- 4) Reset Output 1 by pressing Output 1 button again. Display should resume normal operation with no faults.
- 5) If Output 2 is not available, skip to g) below.

e) Output 2 Verification:

- 1) Make sure that the EF switch is in the ON position on the load bank and turn on Output 2. Contactor must close and indicator on the display illuminate.
- 2) Verify 'ABC' phase rotation at the load bank.
- 3) Turn the EF switch OFF on the load bank and verify that contactor opens and fault is displayed. Red lamp on display should flash.
- 4) Reset Output 2 by pressing Output 2 button again. Display should resume normal operation with no faults.

f) Sensor Testing:

- 1) At rated speed, restrict the air cleaner intake to 5% of the normal inlet area. Blocked Filter warning shall appear with amber light flashing on display. Remove Restriction. Fault will reset automatically. (The left arrow will need to be pressed to remove it from the screen.)
- 2) Disconnect "Low Coolant" switch connector located on the top of the radiator and start your stopwatch. Verify Low Coolant Warning (amber) occurs in less than 1 minute.
- 3) Reconnect the low coolant switch and put on top canopy. Clear Low coolant warning by pressing the engine button.

Operation Manual – ITW GSE 4400 Tier 3

g) Re-checking the entire unit after testing:

- 1) Start the engine. With the engine running at normal rated speed, check the entire unit for vibration and for any parts that may have become loosened during the above checks. Tighten any loose hardware as required.
- 2) Check engine oil pressure at rated speed (2000 RPM). The oil pressure gauge should indicate at least 44.9 psi (3.1 bar) when engine is hot. Also at rated speed, check the engine coolant temperature. The temperature gage should indicate in the range of 180°F to 190°F (82°C to 88°C), depending upon operating conditions.

WARNING

If a metal sounding rod is used to detect bearing noises, exercise extreme care to avoid injury from moving components.

- 3) Check 400 Hz generator bearings. Use a stethoscope or metal sounding rod to listen for unusual noises. If using a metal rod, place one end on the generator housing and hold the other end near the ear. Hold the rod with three fingers and use the index finger and thumb to form a sounding chamber between the rod and the ear. Do NOT allow the rod to touch the ear. Listen for grinding or pounding sounds, which would indicate a defective bearing. An engine noise may be telegraphed to the generator and misinterpreted as a generator noise. Contact the equipment manufacturer if in doubt of bearing serviceability.

3) Generator Set Adjustment

a) Generator Adjustment

The 400 Hz generator is a brushless type requiring no adjustments of any kind.

For the following adjustment, the generator set must be running at rated speed (2000 RPM), under no-load conditions. Adjust the regulator as follows:

1) Output Voltage Adjustment

a) Adjust Voltage Control

The output voltage, at which the generator is regulated, is adjustable using the “Output Voltage screen in the Setup Menu. (See Chapter 1-3, Paragraph 4.1)

Observe the output voltage using a true RMS multimeter. Set the output voltage at 115 VAC line-to-neutral (200 VAC line-to-line).

b) Adjust Line-Drop Compensation

Adjustment of line-drop compensation is made using the “Output 1 (or 2) Compensation” screens in the Setup Menu. (See Chapter 1-3 Paragraph 4.2 & 4.3) To adjust the line-drop compensation, proceed as follows:

- i. Connect the generator set output cables to a load (typically a load bank). Load the generator set with the largest available three-phase load of rated power factor not exceeding the maximum rating of the generator set. (i.e. 72 kW for a 90 kVA at 0.8 pf generator)
- ii. Measure the output voltage at the load end of the cables as you increase the load from zero to the maximum full load rating of the unit. If the voltage at the end of the cable rises or drops more than 1%, decrease or increase the line-drop compensation until the regulation is flat (115 VAC line-to-neutral).

Operation Manual – ITW GSE 4400 Tier 3

b) Basic Engine Adjustments

Adjustment procedures applicable to the diesel engine are included in the engine manufacturer's operation manual, which is referenced in Chapter 5. Refer to the engine operation manual for detailed information on the following engine adjustments.

NOTE: A stroboscope is required for engine idle speed checks.

Engine idle speed (for non-EU engines) is programmed at the factory. If adjustment is required, contact the local engine distributor. The recommended idle speed is 1000 RPM, +/- 25 RPM.

The speed limiting adjustment is also set and sealed at the Cummins factory. Speed should be limited to approximately 2350 RPM. If adjustment is required, contact your local engine distributor.

c) Engine Accessories Adjustment

Alternator and fan belt adjustment: Refer to Section 2-1 and engine manufacturer manual.

4) Generator and Exciter Test

The generator fields and exciter stator may be tested with a Kelvin bridge. This is a double-bridge type instrument required for the very low resistances encountered in this test. It is understood that zero (0) resistance indicates a **SHORTCIRCUITED** condition. An infinite resistance reading indicates an **OPEN CIRCUITED** condition.

- Disconnect generator stator leads at the back of the unit.
- Disconnect the two black exciter field leads (Connector J6/P6) that is located under the back right corner of the unit.
- Check resistance and compare to values.

Test Connection	Resistance (Ohms)
Generator Stator Phase A to N (G1)*	0.0026
Generator Stator Phase B to N (G1)*	0.0026
Generator Stator Phase C to N (G1)*	0.0026
Exciter Stator Field (L2)	29
A - B, B - C, C - A Exciter Armature (G2)	0.041
Generator Revolving Field (L1)	2.1

***NOTE:** The two leads of a phase must be connected when the test is made. Take readings when the unit is cold and in an ambient temperature of 70 °F (21°C.).

Figure 2-3-1: Generator and Exciter Test Readings

Operation Manual – ITW GSE 4400 Tier 3

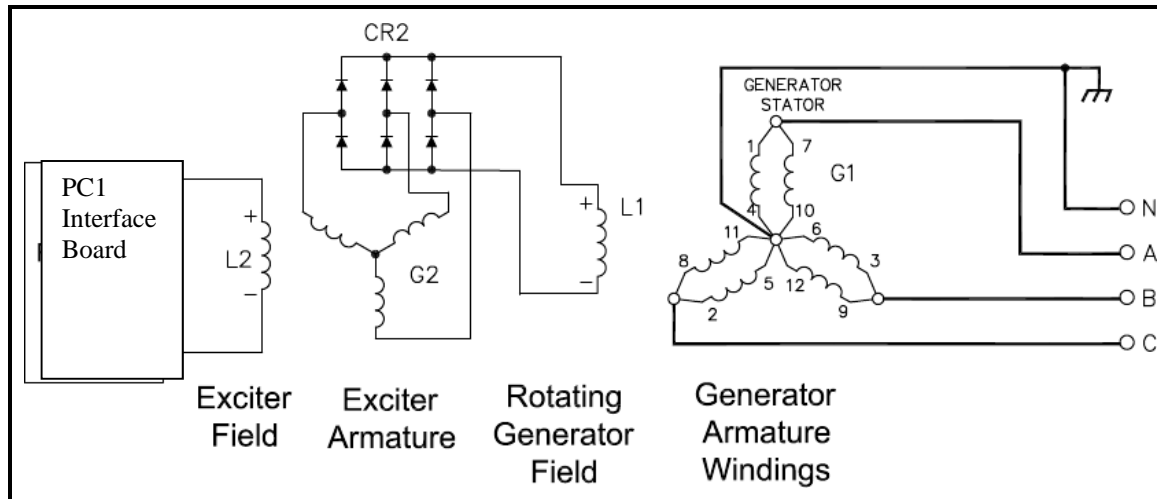

Figure 2-3-2: Generator Connections

5) Diode Test

Test values for diodes are not given here because they could be misleading. Test values may vary even between diodes of the same part number, rating, and manufacturer. General instructions for testing diodes are as follows:

- a) Disconnect exciter windings from diode lead(s).

NOTE: Use a good quality ohmmeter or multimeter. Verify that the instrument is set on its lowest scale. Make certain the battery is in good condition and for analog meters that the pointer is adjusted to zero when the test leads are shorted together.

- b) Hold one ohmmeter lead point on the threaded end of the diode. Hold the other lead point on the wire terminal end. Observe and note the indicated resistance. Now reverse the lead connection on the diode. Observe and note the ohmmeter indicated resistance. If an infinite or very high resistance was indicated with the leads connected one way and a low, readable resistance was indicated with the leads connected the opposite way, the diode may be considered good.

6) Testing the Active Rectifier Unit (ARU) (for units with the DC option)

The 28.5 VDC ARU is an optional add-on to the GPU. The following test procedures may be used for testing the ARU following repair, or for just checking performance.

a) Preparation for Testing

- 1) Connect the ARU to a DC load bank.
- 2) Start the GPU per the operating procedures in Chapter 1, Section 3.

Operation Manual – ITW GSE 4400 Tier 3

b) Operational Test Procedure

1) Power Delivery

- a) Press “**28 VDC**” pushbutton to close the DC output contactor. The green “**DC OUTPUT**” LED will glow indicating that DC power is being delivered to the load bank.
- b) Using a calibrated multimeter, measure the DC voltage at the load bank with no load. The voltage should be 28.5 VDC.
- c) Place a 600 Amp load on the GPU. The measured DC voltage at the load bank should still be 28.5 VDC. Observe the DC voltage and amps on the output screen of the display for accuracy.
- d) If the full load voltage reading is more than 0.5 VDC from the desired output voltage (typically 28.5 VDC) then adjust the line drop compensation using the “28V Compensation” screen in the Setup menu. (See Chapter 1-3 Paragraph 4.18)

2) Discontinue Power Delivery

Press “**28 VDC**” pushbutton to open the DC output contactor. The green LED will turn off, indicating that DC power has been removed from the load bank.

3) Current Limiting / Soft Start Control

The Current Limit default value is set using the “**28V Current Limit**” screen in the Setup Menu (See Chapter 1-3 Paragraph 4.19). To change the value for the current aircraft (and this test), use the RIGHT and LEFT navigation buttons when the diesel is running, the 28VDC ARU is NOT on and the “default” operator screen is displayed. The current limit settings are from 200 amps to 1600 amps for the 400 Amp version of the unit and from 400 amps to 2400 amps for the 600 Amp version.

- a) Start the diesel engine.
- b) Once the engine has stabilized at its running speed, use the Right or Left navigation buttons to set the current limit to 1400 amps.
- c) Press the “**28VDC**” pushbutton to close the contactor to apply the load to the load bank.
- d) Press the “Engine Test” switch on the load bank. Verify that the current never exceeds 1400 amps.
- e) Press “**28 VDC**” pushbutton to open the DC output contactor. The green LED will turn off, indicating that DC power has been removed from the load bank.

Operation Manual – ITW GSE 4400 Tier 3

Section 4 Troubleshooting Procedures

1) General

The Troubleshooting Chart located in this section covers the common faults and malfunctions that can be found during operation or maintenance of this equipment. The chart may not list all faults and malfunctions that can occur. If a fault or malfunction is not listed in the chart, start looking for the cause at the source of power in the affected circuit. Refer to the schematic and connection diagram in Chapter 5. Test the circuit systematically until the source of the malfunction is isolated.

The Troubleshooting Chart is arranged by Error code, Error text, Description and then four columns of possible corrective actions. Always try the 1st corrective action before proceeding to the next corrective action.

WARNING

Exercise extreme care to avoid contact with high voltage leads and components.
HIGH VOLTAGE CAN KILL!

CAUTION

Maintenance personnel must be very careful when performing terminal-to-terminal checks to be certain the proper terminals are being used, especially when using jumper leads. Damage to electrical components may result from the application of improper voltage and current.

2) Equipment for Troubleshooting

A good quality multimeter is the only instrument required for troubleshooting. At least two jumper leads with alligator, or similar clips, will be required. The engine electrical system can be used as a 24 VDC power source.

3) Parts Replacement

To lessen down time and get a faulty machine back on line as quickly as possible, the black box concept of parts replacement is reflected in the Troubleshooting Chart. For example, if a component on a control box board is defective, the quickest way to remedy the situation is to replace the complete board and send the old to stock.

4) Normal Operational Parameters

The system specifications, which are listed in Chapter 1-1, provide useful information when troubleshooting abnormal operation. The Protective System Specifications and Normal Operating Characteristics provide information about how the generator set should be operated.

Operation Manual – ITW GSE 4400 Tier 3

5) Check Connections and Leads

ALWAYS check connections and leads to a component suspected of being faulty. Generally, it is assumed that connections and wiring have been checked first and that power has not been lost as a result of defective wiring or connections.

6) Engine Troubleshooting

Remember that the ability of the engine to start and run properly depends upon the following:

- An adequate supply of 24 VDC power reaching a good starter and control board
- An adequate supply of air, compressed to a sufficiently high pressure
- The injection of the correct amount of clean fuel at the proper time

7) GPU Control Monitoring

The GPU control system performs complete diagnostic testing and continuous monitoring of all critical circuits and operating electrical values. If the control system senses a problem with one of the circuits or if any of the electrical values exceeds its safe operating limit, the control system will shut the GPU down, or may allow the GPU to continue operation depending on the severity of the condition.

a) Operating Modes

1) Self-Test Mode

When power is first applied to the control circuit, the GPU performs complete self-diagnostics of the internal circuitry. If a fault is detected during the self-test, the Alert/Failure LED will be lit and the first (if there are more than one) failure will be displayed on the LED display.

2) Engine Run Mode

When the **ENGINE** pushbutton is pressed, the blue power indicator LED and the Operating Beacon will start flashing. The starter will engage when the engine is ready. After the engine reaches its idle speed (1800 rpm) the GPU is ready to supply power to the aircraft. (Note that the engine will make three 15 second attempts to start the engine. If the engine doesn't successfully start after the third attempt, the fault LED will be lit and an Engine Start Failure message will be displayed.)

3) Engine Shutdown Mode

Pressing the **ENGINE** pushbutton starts the 5 minute delayed shutdown period. If any output contactors are closed, they will open and the display will start counting down from 300 seconds. The shutdown period is required to cool the engine's turbocharger.

4) Automatic Engine Shutdown

Automatic Shutdown mode will turn off the engine after 10 minutes when all contactors are open or if they are closed and the total generator current is less than 5 amps. (This timer is internal and not visible.) After 10 minutes, it puts the engine in shutdown mode. (All contactors are opened and the generator is no longer regulating voltage.) A visible 300 second timer is displayed and the engine will turn off when the timer expires. The Automatic Engine Shutdown mode is changed in the Setup menu and the choices are enabled or disabled.

5) Engine Stop Mode

After the 5 minute delayed shutdown period, the engine stops running.

6) System Off Mode

The power is removed from the GPU's entire control system when the battery disconnect is opened.

Operation Manual – ITW GSE 4400 Tier 3

b) Faults

Faults result when any of the fault limits are exceeded, an internal problem, or under certain conditions where an injury to personnel or damage to an aircraft or the GPU could occur. Faults are also stored in the Black Box memory as event records. (See Chapter 1-3 Paragraph 4.0.3) The fault limits and conditions are preset at the factory.

1) Warning

Warning faults have no effect on the operation of the GPU. An example is an intake air restriction fault due to a dirty filter. Although the GPU continues to operate, the fault LED is lit and the fault text appears on the display. Pressing the **Engine** pushbutton or shutting down the GPU resets the fault.

2) Run Mode

Run mode faults remove power from the aircraft but do not change the operating speed of the engine. An example is an over voltage fault. Although the contactors open and remove power from the aircraft, the engine remains at rated speed, the fault LED is lit and the fault text appears on the display. Pressing the **Engine** pushbutton or shutting down the GPU resets the fault.

3) Stop Mode

Stop mode faults remove power from the aircraft and shut the engine down. An example is a low oil pressure fault. The contactors open and remove power from the aircraft, the engine shuts down, the Alert/Failure LED is lit and the fault text appears display. Pressing the **Engine** pushbutton or shutting down the GPU resets the fault.

8) Cummins Engine Fault Codes & Trouble Shooting

The best source of information to aid in trouble shooting Cummins engine issues is at the quickserve.cummins.com website. Go to this website and register up to five engine serial numbers for free. (It is recommended that if you have more than one engine type/size, that you register one serial number per type/size.) Once you are registered, this website gives you access to engine information, troubleshooting assistance by fault code, parts information and service bulletin information for each serial number/engine type that you have registered with the site.

9) Error Codes

If the displayed text does not provide sufficient information to solve the problem, the tables on the next pages suggest corrective actions to be carried out for each error code.

Additional error information regarding the output voltage and overload, can be derived from the error code according to the following directions:

Output Voltage: 30xx / 31xx / 35xx

Overload: 40xx / 41xx / 42xx / 43xx / 44xx / 45xx / 46xx / 47xx

Phase code:

xx01 = Phase A

xx05 = Phase A & C

xx02 = Phase B

xx06 = Phase B & C

xx03 = Phase A & B

xx07 = Phase A, B & C

xx04 = Phase C

Examples: Error Code 3501 refers to "Output Voltage Too Low" at phase A.

Error Code 4407 refers to "Overload I > 300% - 1 sec." at all 3 output phases.

Operation Manual – ITW GSE 4400 Tier 3

10.0 Troubleshooting Chart

Error Code	Error Text in display	Description	1st Corrective Action	2nd Corrective Action	3rd Corrective Action	4th Corrective Action
For faults in this section: Disconnect from Aircraft (if connected). Do not stop engine (if running). Do not let engine start (if not running).						
100	LOGGING UNSUCCESSFUL	Communication Failure	Press Engine button to Reset			
201	CONTROL BOARD FAILURE	ID chip is missing or unreadable	Inspect ID chip connection. for damage.	Contact ITWGSE		
202	WRONG SOFTWARE VERSION	Wrong Software Version Installed	Install correct software version			
250	FAILED SOFTWARE UPDATE	The new software didn't load properly	Try to install the software again	Replace display or control board		
300	FUEL LEVEL < 10%	Fuel Level is too low to attempt an engine start.	Add Fuel	Inspect fuel Sender wiring	Inspect fuel Sender	
500	STARTER FAILURE	Engine rotation is not detected when starter was activated.	Press Engine button to Reset	Check starter circuit to ensure that it is properly energized. (Replace Starter Solenoid)	Replace Starter	
600	UNABLE TO START ENGINE	Engine did not start after 3 tries.	Press Engine button to Reset	Check fuel valve to ensure it is open.	Service Engine	
700	BATTERY LEVEL TOO LOW	Battery voltage level is too low to attempt startup sequence.	Press Engine button to Reset	Check battery cables	Charge Battery	Replace Battery
1000	OUTPUT VOLTAGE TOO HIGH	400Hz voltage is greater than 130 volts for 250mS.	Press Output Button to Reset	Check voltage set-up value	Replace Control Board A1	Replace Interface Board A2
1100	OUTPUT VOLTAGE TOO HIGH	400Hz voltage is greater than 140 volts for 15mS.	Press Output Button to Reset	Replace Control Board A1	Replace Interface Board A2	
1200	OUTPUT VOLTAGE TOO LOW	400Hz voltage is less than 104 volts for 6 seconds.	Press Output Button to Reset	Check voltage set-up value	Replace Control Board A1	Replace Interface Board A2
1300	OVERLOAD: 100% < I < 125% - 600 s	Current was between 100% and 125% for 10 minutes.	Press Output Button to Reset	Remove overload and re-engage output	Replace Control Board A1	Replace Interface Board A2

Operation Manual – ITW GSE 4400 Tier 3

Error Code	Error Text in display	Description	1st Corrective Action	2nd Corrective Action	3rd Corrective Action	4th Corrective Action
1400	OVERLOAD: 125% < I < 150% - 10 s	Current was between 125% and 150% for 10 seconds	Press Output Button to Reset	Remove overload and re-engage output	Replace Control Board A1	Replace Interface Board A2
1500	OVERLOAD: 150% < I < 175% - 2 s	Current was between 150% and 175% for 2 seconds.	Press Output Button to Reset	Remove overload and re-engage output	Replace Control Board A1	Replace Interface Board A2
1600	OVERLOAD: I > 175% - 1 s	Current was over 175% for 1 second.	Press Output Button to Reset	Remove overload and re-engage output	Replace Control Board A1	Replace Interface Board A2
2000	EF OUTPUT 1 RIPPLE TOO HIGH	Ripple on EF from the aircraft on output 1 is beyond the defined limit.	Press Output 1 button to reset	Check set-up value	Remove load and check output cabling	Replace Control Boards A1 & A2
2100	EF OUTPUT 2 RIPPLE TOO HIGH	Ripple on EF from the aircraft on output 2 is beyond the defined limit.	Press Output 2 button to reset	Check set-up value	Remove load and check output cabling	Replace Control Boards A1 & A2
2200	PLUG 1 TEMPERATURE TOO HIGH	The temperature sensor in output 1 plug has tripped.	Press Output 1 button to reset	Remove load and let plug cool down	Check connector / output cabling for any malfunction	Replace Control Boards A1 & A2
2300	PLUG 2 TEMPERATURES TOO HIGH	The temperature sensor in output 2 plug has tripped.	Press Output 2 button to reset	Remove load and let plug cool down	Check connector / output cabling for any malfunction	Replace Control Boards A1 & A2
2400	28V PLUG TEMPERATURE TOO HIGH	The temperature sensor in output 2 plug has tripped.	Press ARU button to reset	Remove load and let plug cool down	Check connector / output cabling for any malfunction	Replace Control Boards A1 & A2
2700	EF SIGNAL DROP OUT - OUTPUT 1	EF Signal Disappeared at Output 1	Press Output 1 button to reset	Is output cable correctly inserted?	Check / correct installation	Replace Control Boards A1 & A2
2800	EF SIGNAL DROP OUT - OUTPUT 2	EF Signal Disappeared at Output 2	Press Output 2 button to reset	Is output cable correctly inserted?	Check / correct installation	Replace Control Boards A1 & A2
2900	90% SIGNAL DROP OUT - OUTPUT 1	90% Signal Disappeared at Output 1	Press Output 1 button to reset	Is output cable correctly inserted?	Check / correct installation	Replace Control Boards A1 & A2
3000	90% SIGNAL DROP OUT - OUTPUT 2	90% Signal Disappeared at Output 2	Press Output 2 button to reset	Is output cable correctly inserted?	Check / correct installation	Replace Control Boards A1 & A2

Operation Manual – ITW GSE 4400 Tier 3

Error Code	Error Text in display	Description	1st Corrective Action	2nd Corrective Action	3rd Corrective Action	4th Corrective Action
3100	90% SIGNAL DROP OUT - 28 VDC	90% Signal Disappeared at ARU Output	Press ARU button to reset	Is output cable correctly inserted?	Check / correct installation	Replace Control Boards A1 & A2
3200	28V OUTPUT VOLTAGE TOO HIGH	Voltage > 32V - 4s	Press ARU button to reset	Check output voltage setup value	Check ARU Module and wiring	
3300	OUTPUT VOLTAGE TOO HIGH	Voltage > 40V - 1s	Press ARU button to reset	Check output voltage setup value	Check ARU Module and wiring	
3400	28V OUTPUT VOLTAGE TOO LOW	Voltage < 20V - 4s	Press ARU button to reset	Check output voltage setup value	Check ARU Module and wiring	
3500	28V RECTIFIER TEMP TOO HIGH		Press ARU button to reset	Let the unit cool down and reset	Check airflow / air filters / fan	Check temp. sensor at rectifier heat sink.
3600	28V TRANSFORMER TEMP TOO HIGH	ARU Transformer Temperature is too high	Press ARU button to reset	Let the unit cool down and reset	Check airflow / air filters / fan	Check temp. sensor at Transformer.
3800	28V INTERLOCK LEVEL TOO LOW	28V F Level too low	Press ARU button to reset	Verify that output cable is correct inserted	Check / correct installation	Replace Control Board A1 Replace Interface Board A2
3900	SHORT CIRCUIT AT 28V OUTPUT	28V Short Circuited	Press ARU button to reset	Remove overload and re-engage output	Replace Control Board A1	Replace Interface Board A2
4000	28V OUTPUT CURRENT TOO HIGH	28V Output Voltage is too high	Press ARU button to reset	Remove overload and re-engage output	Replace Control Board A1	Replace Interface Board A2
4500	CONTROL BOARD ADC1 FAILURE	ADC1 voltage reading out of range.	Press Engine button to reset	Replace Control Board A1	Replace Interface Board A2	
4600	CONTROL BOARD ADC2 FAILURE	ADC2 voltage reading out of range.	Press Engine button to reset	Replace Control Board A1	Replace Interface Board A2	

Operation Manual – ITW GSE 4400 Tier 3

Error Code	Error Text in display	Description	1st Corrective Action	2nd Corrective Action	3rd Corrective Action	4th Corrective Action
For faults in this section: Disconnect from aircraft. Shut down engine after cooldown.						
6000	CONTROL BOARD FAILURE	Watchdog Timeout	Press Engine Button to reset	Replace Control Board A1		
6100	AVR SOFTSTART ERROR	AVR Soft start Error	Press Engine Button to reset	Check Excitation Wiring/Fuse	Replace Control Board A1	Replace Interface Board A2
6600	ECM ERROR CODE RECEIVED	Engine Error Code Received from ECM	Service Engine			
6900	AVR FAILURE	The duty cycle for the Exciter is too high	Inspect the generator and the exciter circuit for damage or bad connections.	Check fuses F8 and F3	Replace Interface Board A2	Replace Control Board A1
8000	CONTROL VOLTAGE LOW	Control Voltage < 20V (Running)	Press Engine button to reset	Check Alternator	Check Battery	
8200	EMERGENCY STOP ACTIVATED		Release emergency stop and press Engine button to reset	Check emergency stop	Check user EPO (A2:X14)	Replace Control Board A1
8300	GENERATOR FAILURE	Significant voltage imbalance between phases.	Contact ITWGSE DO NOT ATTEMPT TO RESTART ENGINE!			
8400	ECM COMMUNICATION FAILURE	J1939 Communication Failure	Check ECM Power (Replace Interface Board)	Service Engine		
8500	ENGINE RPM OUT OF SPEC	Engine RPM out of specification or stopped	Service Engine			

Operation Manual – ITW GSE 4400 Tier 3

Engine Controls

Trouble, Symptom, Condition	Probable Cause	Test, Check, and/or Remedy
1. The engine will not start, and the starter will not crank the engine.	a. Emergency Stop	<ul style="list-style-type: none"> Make sure the Emergency Stop switch is pulled out and switch has been pressed.
	b. Battery Disconnect switch is in the OFF position.	<ul style="list-style-type: none"> Make sure the battery disconnect switch is in the ON position.
	c. Battery discharged or loose battery or ground connection.	<ul style="list-style-type: none"> Make sure the voltage across the batteries is approximately 25.6 VDC. Check the battery terminals. Be sure 25.6 volts DC is reaching the starter solenoid input terminal.
	d. Defective starter solenoid (SW3).	<ul style="list-style-type: none"> Check if you can hear the starter solenoid activate when the start button is pressed. If not, check for voltage on the starter solenoid coil (see e. below). Temporarily connect a large-capacity jumper cable (No. 1/0 minimum) between the hot side of the starter solenoid and the starter input terminal. If starter does not crank engine, the starter may be defective
	e. No voltage at starter solenoid coil.	<ul style="list-style-type: none"> Check connector X5 on the PC1 Interface board. Verify that there is 24 VDC across the starter solenoid + and – terminals when the engine start pushbutton is pressed. Check and replace (if necessary) the Interface board.
	f. Defective starter.	Remove the starter motor from engine and apply 24VDC to test it. Replace the starter if non-operable.
	g. Internal seizure.	If the starter is good, attempt to hand crank the engine using a 3/4-inch square drive on the crankshaft pulley. If engine cannot be turned one complete revolution, internal seizure is indicated. Remove engine and contact the engine manufacturer and/or nearest dealer.
	i. Defective Control Panel	Replace the Control Panel.
	2. Engine will not start. Starter clicks on and off.	a. Low battery output
b. Loose starting circuit connections or faulty cables		Check all connections and cables. Tighten or replace as required.

Operation Manual – ITW GSE 4400 Tier 3

Engine Controls (continued)

Trouble, Symptom, Condition	Probable Cause	Test, Check, and/or Remedy
3. Engine will not start. Cranking speed is low.	a. Low battery output	Check the battery and recharge or replace
	b. Loose starting circuit connections or faulty cables	Check all connections and cables. Tighten or replace as required.
	c. Improper lubricating oil viscosity	Check the oil. Refer to Section 2-2. Remove and replace the oil as necessary.
4. Engine cranks but will not start. Caution: To prevent damage to the starting motor, do not engage the starting motor for more than 30 seconds. Wait two (2) minutes between each attempt to start.	a. Low fuel	Make sure there is sufficient fuel in the fuel tank. <ul style="list-style-type: none"> If engine will not start, the fuel pump may be defective. If engine starts and then stops after a short time, check fuel lines, and filters.
	b. Fuel shutoff valve closed	Open the shutoff valve on the fuel tank.
	c. Plugged or defective filter	Replace fuel filters. Also, check the gaskets for leaking or damaged condition.
	d. Loose connections, damaged hoses or fuel lines between tank and fuel pump	Tighten all fittings and connections. Replace any damaged hoses or fuel links.
5. Engine cranks, but will not start. Over-temperature indication appears immediately.	a. Defective engine temperature switch	Check wiring to engine high temperature switch (S49 on schematic), which is located on top of the engine block. If wiring is correct, remove wires and check resistance between terminals C and N.O. A resistance of less than 10 ohms indicates a defective switch. Replace switch if defective.
	b. Defective PC1 board	Replace the PC1 Interface board.
6. Engine is hard to start. Cranking speed is normal and the fuel supply is adequate.	a. Low compression, which may be caused by sticking or burned exhaust valves, worn or broken compression rings, leaking cylinder head gasket, or valve clearance adjustment.	Check the compression in accordance with instructions in the engine manufacturer's operation manual. Overhaul the engine to make repairs as necessary.
7. Engine starts but then stops after a few seconds by automatic shutdown.	a. Low oil pressure or defective oil pressure switch.	Restart the engine and observe oil pressure gauge. If oil pressure is 12 psi or more, disconnect wire from the normally-closed switch terminal on the oil pressure switch. Restart engine. If engine continues to run, the oil pressure switch is defective. Replace oil pressure switch. If engine stops, the PC1 Interface board might be defective.
	b. Defective PC1 board.	Replace PC1 Interface board.

Operation Manual – ITW GSE 4400 Tier 3

Engine Controls (continued)

Trouble, Symptom, Condition	Probable Cause	Test, Check, and/or Remedy
8. Engine either goes from rated speed to idle speed, or shuts down.	a. Low fuel was detected or the PC1 board could be defective.	Add No. 2 diesel fuel. Replace PC1 Interface board.
9. Engine has slow response time when a load is applied.	a. Engine needs tune-up.	Tune-up as required. Refer to engine manufacturer's operation manual.
10. Engine misses or runs unevenly.	a. Insufficient fuel.	Check fuel system in accordance with engine manufacturer's operation manual. Repair or replace parts as required.
	b. Faulty injector.	Check injectors in accordance with engine manufacturer's operation manual.
	c. Low compression pressure.	Check compression in accordance with engine manufacturer's operation manual.
	d. Air in fuel system.	Check all fittings to be sure they are tight and the thread sealant is still present. Tighten the fittings and add new thread sealant as required.
11. Engine lacks power	a. Improper engine adjustments and gear train timing.	Tune-up engine in accordance with engine manufacturer's operation manual.
	b. Insufficient fuel.	Check low fuel level in accordance with engine manufacturer's operation manual. Repair or replace parts as required.
	c. Insufficient inlet air due to damaged or dirty air cleaner.	Check air cleaner for plugging and/or damage.
	d. Restricted exhaust system.	Check exhaust pipes for restrictions. Check muffler for clogged condition. Replace as required.
12. Front clearance lights aren't ON.	a. Loose connection	<ul style="list-style-type: none"> • Check Interface board connector X9 terminal 3. • Check Ground plate connection of wire 79
	b. Defective Interface board.	Replace Interface board.
13. Rear clearance lights aren't ON.	a. Loose connection	<ul style="list-style-type: none"> • Check quick disconnect plug P4 • Check Interface board connector X9 terminal 4. • Check Interface board connector X45 wire 80.

Operation Manual – ITW GSE 4400 Tier 3

Generator Excitation Circuits

Trouble, Symptom, Condition	Probable Cause	Test, Check, and/or Remedy
1. No (or low) generator output voltage in all phases. Generator operating at 400 Hz.	a. Defective generator or excitation circuit.	In the Setup Menu, go to the Diagnostic Mode screen (Section 1-3 Paragraph 4.20) and set it to AVR Battery Only. This applies 24 VDC from the battery to the exciter field, which should produce an indicated output voltage of 100 +/- 20 VAC line to neutral.
	b. Verify 24 VDC across connector J6 terminals A & B.	Check X20 on the Interface board and connector J6 at the generator.
	c. Defective connector at voltage regulator, or defective wiring from regulator to exciter field	Disconnect the exciter wires at the terminal strip J6. Using jumper leads with clip terminals, connect 24 VDC to wires. If generator produces at least 80 VAC, replace or repair the connector and wiring between voltage regulator and exciter field as required.

Operation Manual – ITW GSE 4400 Tier 3

Generator

Trouble, Symptom, Condition	Probable Cause	Test, Check, and/or Remedy
1. No (or low) voltage output	a. Shorted diode in exciter rectifier (CR2).	Check diodes in accordance with Chapter 2-3 Section 4 and 5. If diodes are good, proceed to step b.
	b. Open or shorted exciter rotor winding (G2).	Use ohmmeter to check for open or shorted condition diodes in accordance with Chapter 2-3 Section 4 and 5. If exciter rotor windings are good, proceed to step C.
	c. Open or shorted exciter field windings (L2).	Check field resistance. See Chapter 2-3 Section 4 for normal values.
	d. Open or shorted generator rotor windings (L1).	Check resistance with ohmmeter to determine if open or short circuited diodes in accordance with Chapter 2-3 Section 4 and 5.
2. Generator operates single phase.	a. Open or short circuited winding in generator stator (G1).	Check stator-winding resistances. See Chapter 2-3 Section 4 for normal values.
3. Generator overheats	a. Loose connection causing high resistance.	Check all output connections. Look for discoloration caused by heat. Tighten or replace as required.
	b. Improper or blocked ventilation.	Check for foreign material (rags, etc.) blocking airflow. Provide adequate ventilation.
	c. Generator stator windings short circuited.	Check stator windings. See Chapter 2-3 Section 4.
4. Unbalanced output	a. Loose connection in output circuit.	Check all output connections. Discolored connectors indicate a loose connection. Tighten or replace as required.
	b. Open or short-circuited phase.	Check stator windings in accordance with Chapter 2-3 Section 4. Repair or replace as required.
	c. Defective connection in output circuit.	Check the plug and receptacle connectors at aircraft. Tighten, repair, or replace as required.
	d. Break or cut in output cable assembly.	Inspect the output cable for damage.
	e. Unbalanced load.	Check the aircraft 400-Hz components.

Operation Manual – ITW GSE 4400 Tier 3

Load Contactor Operating Circuits

Output 1: Contactor K1

Output 2: Contactor K2

Trouble, Symptom, Condition	Probable Cause	Test, Check, and/or Remedy
1. Load contactor will not close when the corresponding Output pushbutton is pressed. Generator is running at normal voltage.	a. Blown contactor fuse (F3) on regulator board.	Check the fuse and replace if blown. If it blows again, check the contactor.
	b. Defective display module	Check to make sure that the other pushbuttons on the control panel work. Replace the display board and test all buttons again.
2. Load contactor closes when the Output pushbutton is pressed, but opens within 10 seconds.	a. The plug interlock EF circuit on Interface board could be defective.	Set 400 Hz Interlock to Bypassed. If load contactor remains closed, proceed to step b .
	b. 28.5 VDC is not reaching the plug interlock EF circuit from aircraft for following reasons:	Proceed as follows to find the cause of this malfunction.
	c. Generator-to-aircraft cable connector defective or not plugged into aircraft receptacle connector	Inspect cable connector plug thoroughly for damaged E and F terminals. Be sure plug is fully mated with aircraft receptacle connector and making good contact.
	d. Aircraft rejecting power.	Check aircraft on-board electrical equipment and controls.
	e. Defective contacts in switch mounted on side of contactor.	Connect a jumper lead between terminals of the normally-open auxiliary switch. If the contactor now remains closed, replace the auxiliary switch or the entire contactor.

Operation Manual – ITW GSE 4400 Tier 3

Protective Circuit

NOTE: Protective monitoring is not completely functional until the load contactor is CLOSED. Since it is not advisable to vary voltages for test purposes while delivering power to an aircraft, the GPU should be connected to a load bank for trouble shooting protective circuits.

Trouble, Symptom, Condition	Probable Cause	Test, Check, and/or Remedy
1. Load contactor opens during power delivery. Over voltage fault indicated.	a. Over-voltage condition may have been the result of a sudden drop in load and may have been a normal action.	Press appropriate Output pushbutton and resume power delivery. Observe voltmeter to be certain voltage is normal (115 VAC). Adjust to normal if necessary. If load contactor is opened again and the fault message indicates an over-voltage condition, proceed to step b .
	b. Defective Interface or control board.	With load bank at no load, use the Output Voltage screen in the Setup menu (Chapter 1-3 Paragraph 4.1) to reduce the voltage to 110 VAC. Observe the voltmeter on the load bank and gradually increase voltage. If the load contactor opens at any value less than 125 VAC replace the interface and processor board.
2. Load contactor opens during power delivery. Under voltage fault indicated.	a. Under-voltage condition may have been result of a sudden shock load, or possible tampering with REG potentiometer, and may have been a normal action.	Press appropriate Output pushbutton and resume power delivery. Observe voltmeter to be certain voltage is normal (115 VAC). Adjust to normal if necessary. If load contactor is opened again and the fault message indicates an under-voltage condition, proceed to step b .
	b. Defective Interface or Control board.	With load bank at no load, use the Output Voltage screen in the Setup menu (Chapter 1-3 Paragraph 4.1) to slowly reduce the voltage to 100 VAC. If the load contactor opens at any value above 104 VAC, replace the interface and processor board.

Chapter 3 Manufacturer's Literature

Vendor Literature

Type	Diagram Description
Engine	Operation and Maintenance Manual (Cummins Bulletin # 4021531) Parts Catalog (Cummins Bulletin # 4056563) - Not Included -- purchased separately from Cummins.

Diagram Number	Diagram Description
293145	Diagram, Schematic & Connection

Contact ITW GSE if copies of these drawings or manuals are not delivered with the unit (unless otherwise noted above). Refer to Appendix A for specific information on the ITW GSE 4400, 400 Hz. Generator Set, optional equipment.

Operation Manual – ITW GSE 4400 Tier 3

This page is intentionally left blank.

Appendix A Active Rectifier Unit (ARU)

All ITW GSE 4400 units can be equipped with a 28 VDC Active Rectifier Unit (ARU) output.

Both 400 Hz & 28 VDC outputs can be used simultaneously. The total continuous amount of power from the unit is calculated as the sum of 400 Hz and 28 VDC output and cannot exceed the total 400 Hz power rating of the unit.

A.1 General Description

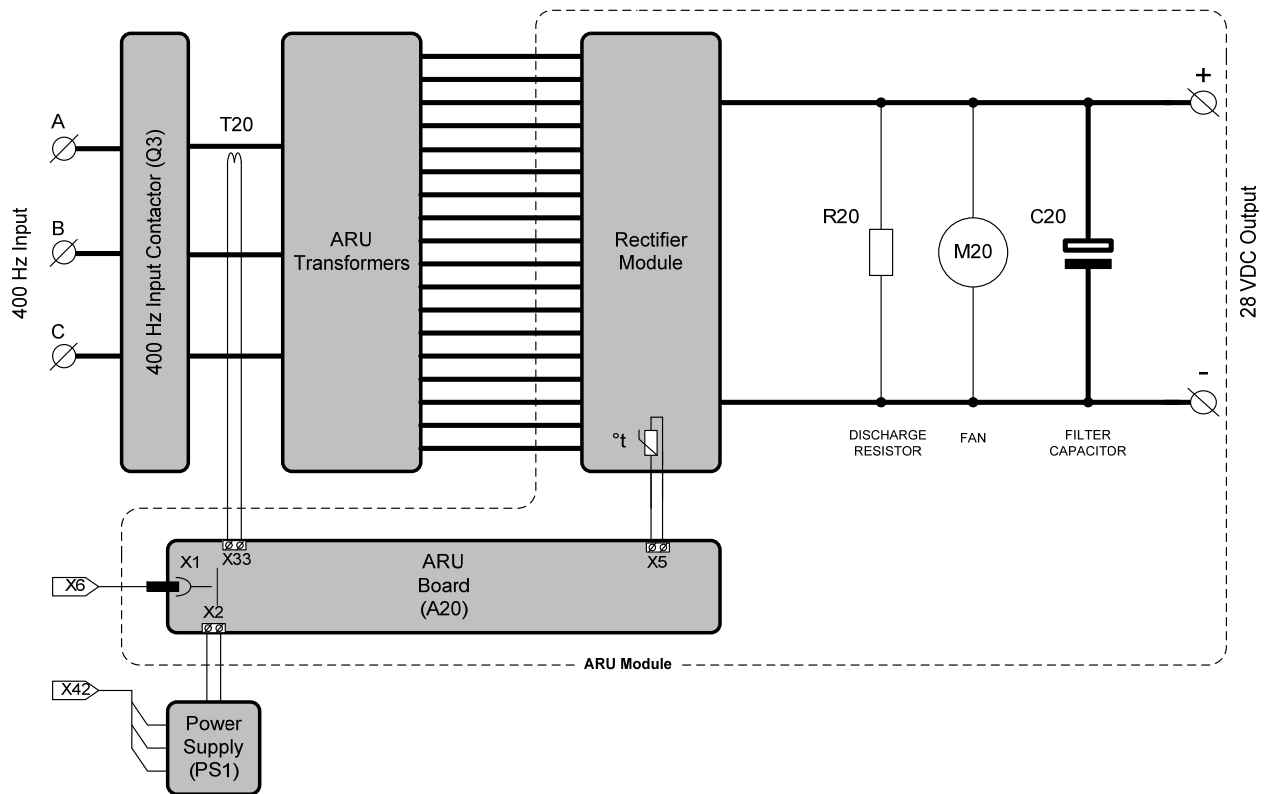

A-1-1 Principle of 28 VDC ARU

The 28 VDC module is an Active Rectifier Unit which is supplied from the 400 Hz generator, where the 28 VDC output voltage is controlled regardless of the 400 Hz output voltage. The DC output current is calculated very precisely on the basis of the 400 Hz parameters using the current transformer T20, located on phase A at the power input.

Input Contactor (Q3):

The 400 Hz input power to the ARU is supplied and controlled via Q3. When this contactor is closed, 28.5 VDC power is supplied to the aircraft.

Power Supply (PS1):

The power to the ARU control board (A20) is isolated from the unit using a DC/DC power supply (PS1) which is rated at 24 VDC / 1 A. This module receives its power from the PC1 interface board, terminal X42.

Operation Manual – ITW GSE 4400 Tier 3

ARU Transformers (T20):

The ARU transformers steps down the 3 phased 400 Hz voltage (3 x 200 Vac) to an appropriate level for obtaining 28 VDC at the output.

ARU Rectifier (PM20):

The output voltage is kept at 28 VDC by using thyristors, regardless of the input voltage level and the load.

ARU Board (A20):

The ARU Board interfaces with the processor board and the rest of the 28 VDC unit.

- Supplied from PS1 (X2)
- Connection to ARU control input on A2 (X1)
- Control of thyristors.
- Measures the output voltage.
- Opens and closes the 400 Hz Input Contactor Q3
- Interface for heatsink thermostat (X5)
- Input for current transformer T20 (X6)

Resistor (R20):

The discharge resistor R20 is part of the output filter stage and discharges the capacitor C20, when the unit is turned off.

Filter Capacitors (C20)

The output filter capacitors are also part of the output filter stage and secures that the AC ripple is kept to a minimum, less than 2% at the output.

Fan (M20)

The fan M20 is part of the total forced cooling of the unit, the primary task for the fan is to cool down the rectifier module.

A.2 Connection of Cables



Fig. A-2-1 Connection of Cables

Recommended output cable to the aircraft is 2 x 4/0 (95 mm²) for continuous loads up to 400 amps (as shown above) and 4 x 4/0 (95 mm²) for higher continuous loads.

Operation Manual – ITW GSE 4400 Tier 3

A.3 Safety Interlock

To ensure personnel health and safety, the converter is equipped with an interlock system. * The system ensures that the output only stays engaged while the plug is inserted into the aircraft receptacle. (28 VDC must be present at terminal strip TB3 lug 5.)

*This option requires a “split-C” connector, which is typically a special order from most aircraft cable manufacturers.

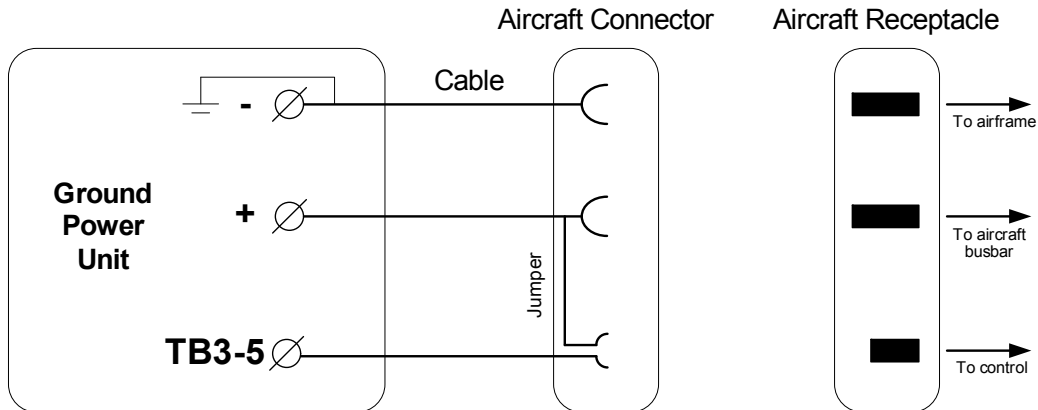

A-3-1 Standard wiring diagram

For service, maintenance and test purposes, the interlock system can be by-passed via the display setup. To ensure personnel health and safety, the converter automatically returns into normal mode once it receives a 28 VDC voltage at terminal TB3-5. (e.g. when the plug is connected to an aircraft.)

Note! The interlock will not work correctly unless the negative busbar **has** a connection to the ground block. (The ARU comes equipped with this connection already made, but it might have been removed to meet other requirements.) If the interlock is not going to be used, a minimum of an 18AWG wire should be connected from the + busbar to Terminal 3 lug 5 (wire 34).

A.4 Operator's Instruction

- To adapt the 28 VDC output power to different types of aircraft, it is possible to set a maximum DC current level in selectable steps of 50, 100, 200 and 300 A. The actual step size is selected in the Setup Menu.
- **NOTE!** The unit remembers the last current limit value that was selected. Make sure this value is not too high for the aircraft being powered.

Operation Manual – ITW GSE 4400 Tier 3

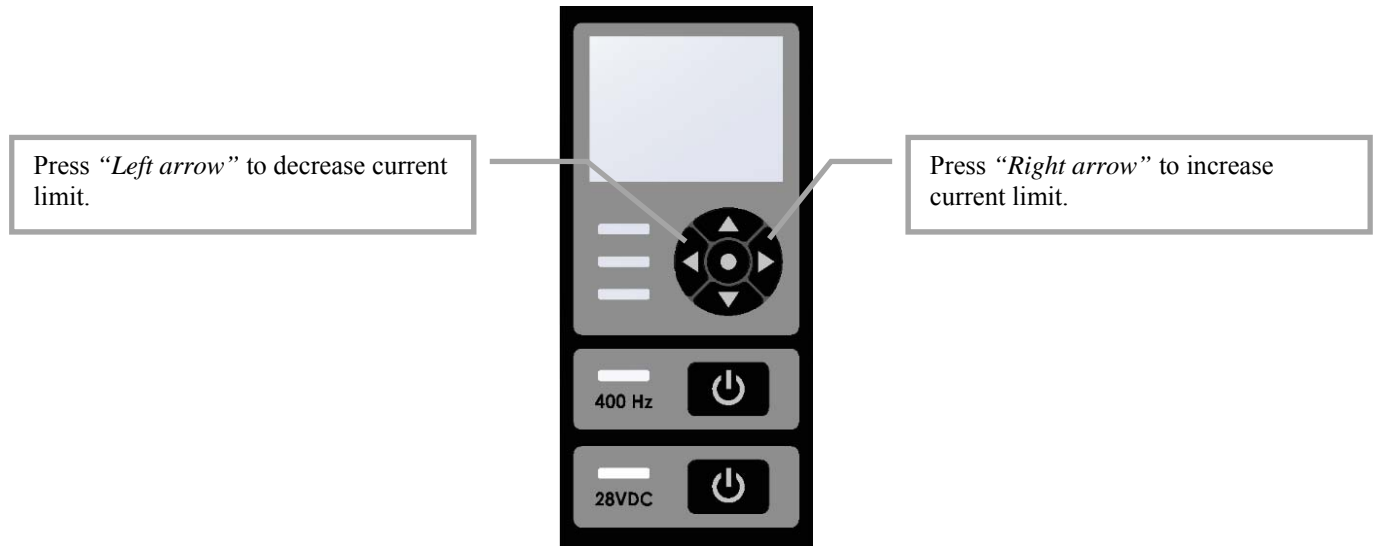

- Insert the aircraft cable into the aircraft. Make sure the cable is inserted till you feel a natural resistance. The plug may be equipped with an Aircraft Connector switch (Split-C or micro-switch). In this case, the ARU will not turn on if the plug is not fully inserted.

- Press the 28 VDC Start/Stop button 

- The unit is now in operation and ready to supply the aircraft with power. This is also indicated via the green LED located close to the 28 VDC Start/Stop button.



- If the unit shuts off and no longer is supplying power to the aircraft, this is reported in clear text in the display. Also, a corrective action is displayed.
- During operation, various parameters can be viewed via the display. Use the navigation keys ▼ ▲ to browse through the available screens:

Operation Manual – ITW GSE 4400 Tier 3

Default Display Screen Standby

- After operation, the unit has to be removing the aircraft plug.

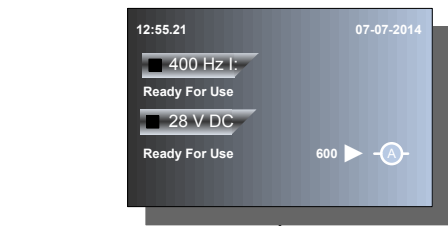

Press Start/Stop button

Use the the ▼/▲ to browse through the various screens.

Use ◀ to leave the sub-menu and return to Default Screen.

Notice!
Parameters may vary depending on the mode of the unit Standby / operating / load profile etc.

Note!

Please note that the 28 VDC

Default Display Screen Operating

If, for some reason, the unit stops due to an error / press the Start/Stop/Reset to reset the unit, once

have and

maintenance. this will remove

Use the the ▼/▲ to browse through the various screens.

Use ◀ to leave the sub-menu and return to Default Screen.

Notice!
Parameters may vary depending on the mode of the unit Standby / operating / load profile etc.

the actual fault)

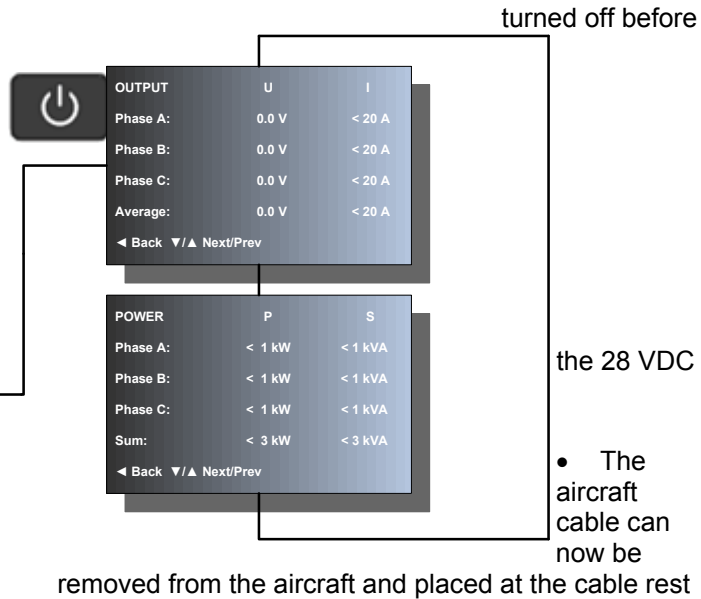

Start/Stop button also functions as a Reset push button.

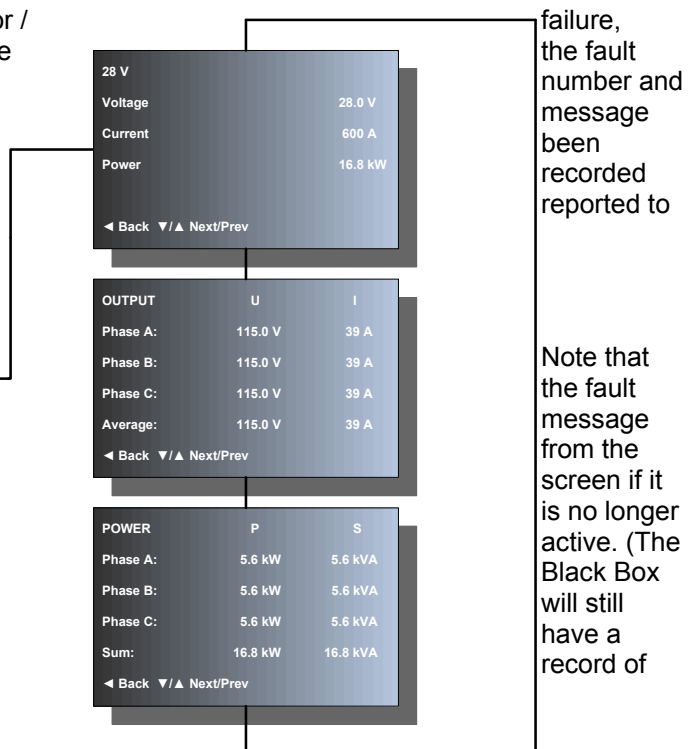

Operation Manual – ITW GSE 4400 Tier 3

A.6 Additional menu items for ARU

Parameters – ARU additional parameters

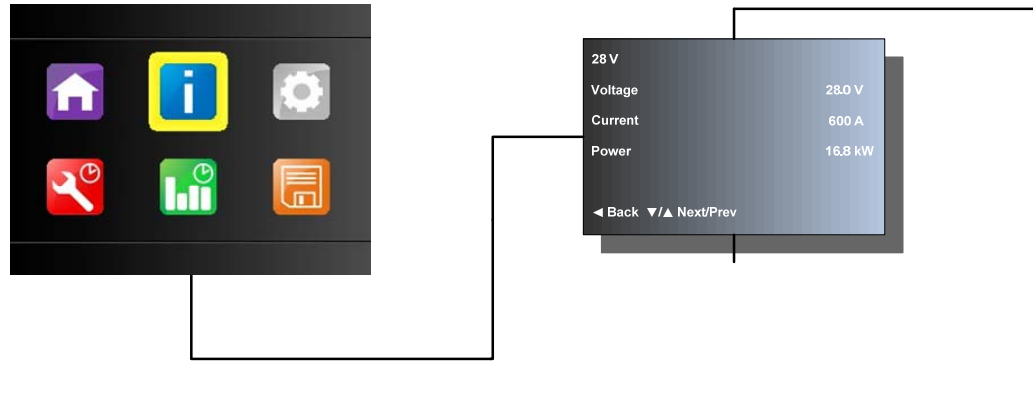

Use the the ▼/▲ to browse through the various screens.

Use ◀ to leave the sub-menu and return to basic Icon Menu.

Notice!
Parameters may vary depending on the mode of the unit
Standby / operating / load profile etc.

Operation Manual – ITW GSE 4400 Tier 3

Setup – ARU additional parameters

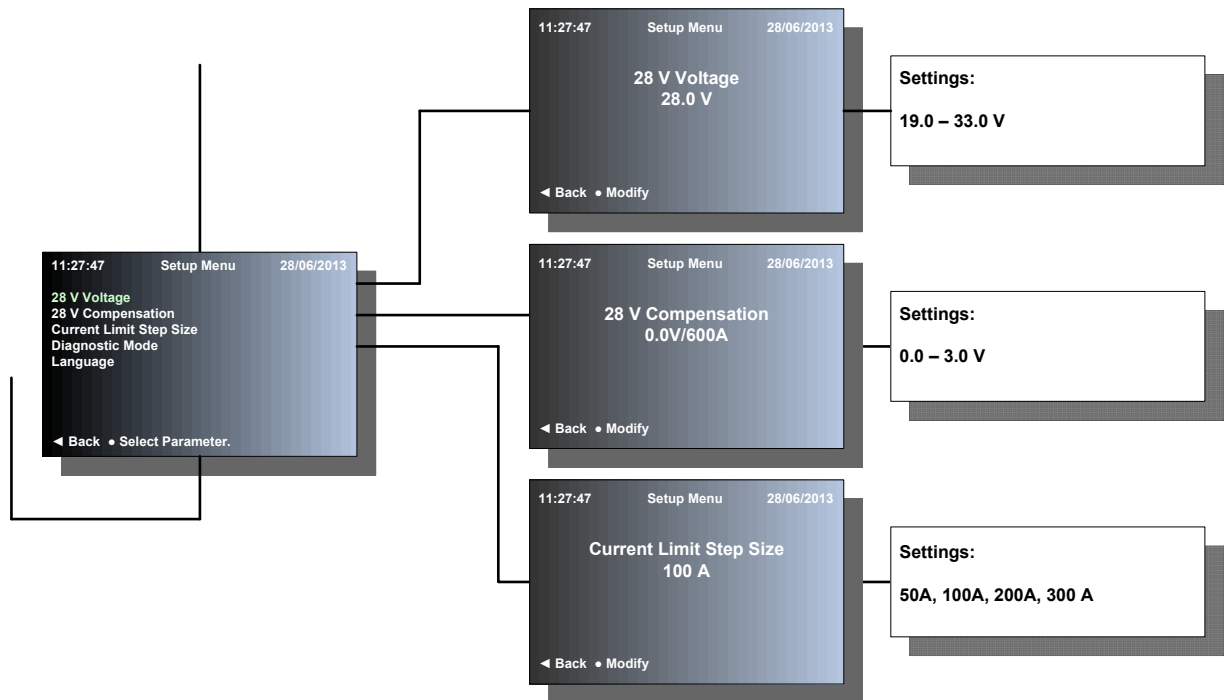

A.7 ARU Default Factory Settings:

28 V Voltage (V):	28.0
28 V Compensation (V/600 A):	0.0 (Set if GPU is supplied with cable)
28 V Current Limit (A):	800 A
Output Mode:	Simultaneous
Fan Control:	Normal
Plug Temperature:	Normally Open

A.8 28V Voltage:

This Setup submenu allows the 28-volt output to be adjusted between 19.0 VDC and 33.0 VDC using the UP and DOWN navigation buttons. (Please note that the acceptable voltage range for all commercial DC powered aircraft is 26V to 29V.

Enter the Setup Menu and then scroll up or down to the 28V Voltage submenu. Press the center ● button to enter the submenu, and then press the ● button again to allow the value to be changed. Press the up or down arrow buttons to change the selection. Press the center ● button to record the new value. Press the LEFT arrow button to exit the submenu and return to the submenu list.

A.9 28V Compensation:

DC voltage drops quickly as the current increases over a given length of cable. This Setup submenu allows 28 volt output to be automatically adjusted as the load increases. The allowed setting is between

Operation Manual – ITW GSE 4400 Tier 3

0.0 and 3.0 VDC at the rated continuous load of the unit. Note that the maximum output voltage of the unit is 33 VDC.

Enter the Setup Menu and then scroll up or down to the 28V Compensation submenu. Press the center ● button to enter the submenu, and then press the ● button again to allow the value to be changed. Press the up or down arrow buttons to change the selection. Press the center ● button to record the new value. Press the LEFT arrow button to exit the submenu and return to the submenu list.

A.10 Current Limit Step Size:

If too much current is supplied to an engine, it is possible for the engine to shear the engines propeller shaft. This Setup submenu is used to set the default limit for current the 28 VDC module will supply to start the aircrafts engine. Typically, this value is set to the maximum current of the smallest aircraft the unit will service. If more current is required for larger aircraft, then the operator can adjust the current limit using the UP and Down buttons at the bottom of the operator panel. The current limit settings are from 300 amps to 2400 amps in steps of 50/100/200/300 amps. This menu selects the size of the steps that the operator uses to adjust the current limit before turning on the 28 VDC to the aircraft.

Enter the Setup Menu and then scroll up or down to the Current Limit Step Size submenu. Press the center ● button to enter the submenu, and then press the ● button again to allow the value to be changed. Press the up or down arrow buttons to change the selection. Press the center ● button to record the new value. Press the LEFT arrow button to exit the submenu and return to the submenu list.

A.11 Specifications

Output:

Voltage:	28 VDC
Current:	600 A continuously
Voltage regulation:	< 0.5%
Voltage ripple:	< 2%
Voltage transient recovery:	Complies with ISO 6858 / MIL-704F
Overload capability:	1200 A for 30 seconds 1800 A for 10 seconds 2000 A for 5 seconds

To protect the aircraft, the output voltage is decreased by 1 V per 300 A in the overload range (300-2400 A).

Setup:

Output voltage:	19-33 V
Voltage compensation:	0-3 V per 600 A
Current limit:	300-2400 A in selectable steps of 50A, 100A, 200A or 300A

Protections:

- Rectifier temperature to high
- Short circuit at output
- Over-and under voltage at output in case:
 - U < 20 VDC for more than 4 seconds
 - U > 32 VDC for more than 4 seconds
 - U > 40 VDC for more than 150 ms

Physical:

Additional weight to unit: 136 kg (300 pounds)

Operation Manual – ITW GSE 4400 Tier 3

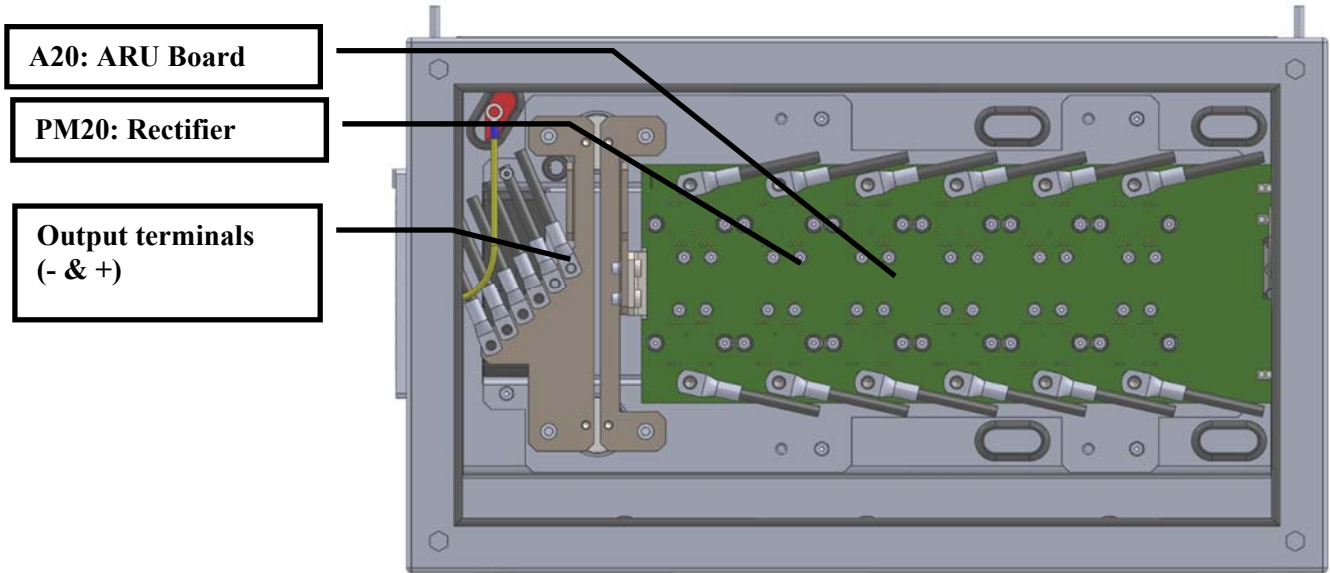

Figure A13-1 Front View (ARU)

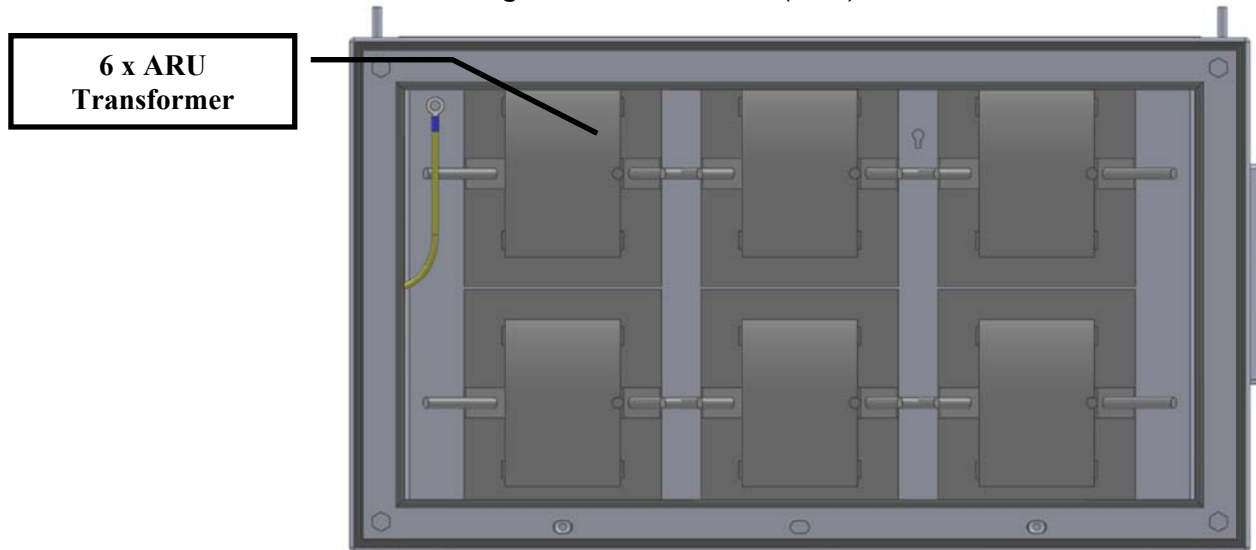

Figure A13-2 Rear View (ARU)

Operation Manual – ITW GSE 4400 Tier 3

Appendix B Options

The following is a list of options available for the ITW GSE 4400, 400 Hz. Generator Set. This chart contains the description and part number of the option. The description of each option follows on the pages below.

Option/Features Available	
Description	Part Number
DIN40 Towbar	293148
Kit, Clearance Lights	293098
Kit, Beacon, Unit Operating, Amber	293099-001
Kit, Beacon, Unit Operating, Blue	293099-002
Kit, Beacon, Unit Operating, Clear	293099-003
Kit, Beacon, Unit Operating, Red	293099-004
Kit, Beacon, Low Fuel, Amber	293100-001
Kit, Beacon, Low Fuel, Blue	293100-002
Kit, Beacon, Low Fuel, Clear	293100-003
Kit, Beacon, Low Fuel, Red	293100-004
Kit, Battery Blanket, 120V	293498-02
Kit, Battery Blanket 240 Volt	293498-04
Kit, Block Heater 120 V	293125-001
Kit, Block Heater 240V	293125-002
Kit, Single Output Towbar Interlock	293337-01
Kit, Dual Output or 28VDC & 1 Output Towbar Interlock	293337-03
Kit, 28VDC and Dual 400 Hz Outputs Towbar Interlock	293337-04

293148 DIN40 Tow bar

This option replaces the standard Towbar with a 40mm diameter eye version.

293098 Kit, Clearance Lights

This option adds clearance lights to the four top corners of the canopy.

- 293099-001 Kit, Beacon, Unit Operating, Amber**
- 293099-002 Kit, Beacon, Unit Operating, Blue**
- 293099-003 Kit, Beacon, Unit Operating, Clear**
- 293099-004 Kit, Beacon, Unit Operating, Red**

This option adds the selected color beacon light to the top of the front canopy. These beacons are delivered with a flashing light. If a steady light is desired, the jumper in the bottom of the light should be cut.

- 293100-001 Kit, Beacon, Low Fuel, Amber**
- 293100-002 Kit, Beacon, Low Fuel, Blue**
- 293100-003 Kit, Beacon, Low Fuel, Clear**
- 293100-004 Kit, Beacon, Low Fuel, Red**

Operation Manual – ITW GSE 4400 Tier 3

This option adds the selected color beacon light to the top of the front canopy. These beacons are delivered with a flashing light. If a steady light is desired, the jumper in the bottom of the light should be cut.

293498-02 Kit, Battery Blanket, 120V

This option adds an independently powered 120 VAC powered battery blanket on top of the batteries in the right cable tray.

293498-04 Kit, Battery Blanket, 240V

This option adds an independently powered 240 VAC powered battery blanket on top of the batteries in the right cable tray.

293503-02 Kit, Block Heater, 120V

This option adds an independently powered 120 VAC powered block heater to the engine.

293503-04 Kit, Block Heater, 240V

This option adds an independently powered 240 VAC powered block heater to the engine.

293337-01 Kit, Single Output Tow Hitch Interlock

This option adds a lock to the tow bar assembly to prevent it from being lowered if the single 400 Hz cable isn't properly inserted into the receptacle at the front of the cable tray. **NOTE:** When this option is installed, the unit will not close the 400 Hz contactor if the tow bar hitch isn't up and locked in place.

293337-03 Kit, Dual Output or 28VDC & 1 Output Tow Hitch Interlock

This option adds a lock to the tow bar assembly to prevent it from being lowered if both the 400 Hz and/or 28VDC cables aren't properly inserted into the receptacles at the front of their respective cable trays.

NOTE: When this option is installed, the unit will not close either output contactor if the tow bar hitch isn't up and locked in place.

293337-04 Kit, 28VDC and Dual 400 Hz Outputs Tow Hitch Interlock

This option adds a lock to the tow bar assembly to prevent it from being lowered if both the 400 Hz and 28VDC cables aren't properly inserted into the receptacles at the front of their respective cable trays.

NOTE: When this option is installed, the unit will not close any output contactor if the tow bar hitch isn't up and locked in place.

Appendix C Operating in Unusual Service Conditions

This information is a general guideline and cannot cover all possible conditions of equipment use. The specific local environments may be dependent upon conditions beyond the manufacturer's control. The manufacturer should be consulted if any unusual conditions of use exist which may affect the physical condition or operation of the equipment or safety to surrounding personnel.

Among such conditions are:

1) Exposure to:

- a) Combustible, explosive, abrasive or conducting dusts.
- b) Environments where the accumulation of lint or excessive dirt will interfere with normal ventilation.
- c) Chemical fumes, flammable, or explosive gases.
- d) Nuclear radiation.
- e) Steam, salt-laden air, or oil vapor.
- f) Damp or very dry locations, radiant heat, vermin infestation, or atmospheres conducive to fungus growth.
- g) Abnormal shock, vibration or mechanical loading from external sources during equipment operation.
- h) Abnormal axial or side thrust imposed on rotating equipment shafts.
- i) Low and/or high ambient temperatures.
- j) High electromagnetic fields

2) Operation at:

- a) Voltages above or below rated voltage.
- b) Speeds other than rated speed.
- c) Frequency other than rated frequency.
- d) Standstill with rotating equipment windings energized.
- e) Unbalanced voltages.
- f) Operation at loads greater than rated.

3) Operation where low acoustical noise levels are required.

4) Operation with:

- a) Improper fuel, lubricants or coolant.
- b) Parts or elements unauthorized by the manufacturer.
- c) Unauthorized modifications.

5) Operation in poorly ventilated areas.

Appendix D Initial Software Installation Procedure

Introduction:

The ITW GSE 4400 GPU contains two circuit boards that may need to be programmed if they are replaced. (The Control Board (P/N AP-579526) and the Display Board (P/N AP-579536)).

This document instructs you how to perform this task. Make sure to program the boards with the correct software number and revision. Install the Control Board software first, then the Display Board software.

First time programming of the Control Board (P/N AP-579526):

- 1) Make sure the Control Board is installed onto the Interface Board (P/N AP-279534), and the GPU is powered.
- 2) Copy the correct Control Board software onto a USB stick. The file must be located in the root folder of the USB stick, and the filename must be *XXXXX.itw*. Other files, e.g. the Display Board software, may also be on the USB stick.
- 3) Inspect the blue LED next to the USB socket on the Control Board. The blue LED must be flashing in a sequence of two rapid flashes, then a pause, then two rapid flashes, and so on.
- 4) Insert the USB stick into the USB socket on the Control Board. Check that the blue LED turns off. Wait until the blue LED turns on (this may take some time).
- 5) When the blue LED turns constantly on, the software has been programmed into the Control Board. Remove the USB stick from the Control Board.

If the blue LED is constantly on, the Control Board has already been programmed. Use the update function on the Display Board to program the Control Board. (The Display Board must be programmed first)

If the blue LED is flashing slowly in a sequence of one flash, a pause, one flash and so on, the microcontroller on the Control Board has lost its internal programming, most likely due to a faulty or missing battery. Contact ITW GSE technical support and request a replacement control board.

First time programming of the Display Board (P/N AP-579536):

- 1) Make sure that switch 1 on DIP-switch SW2 is in the ON position. This allows access to the Display Board menu.
- 2) Copy the correct Display Board software onto a USB stick. The Display Board software consists of two files: a *XXXXX.itw* file, and a file like *AAxxxxxx.pbe*, where *xxxxxx* is a number.
- 3) Do not change the filenames. The two files will only work together.
- 4) The files are located in the root folder of the USB stick. Other files, e.g. the Control Board software, may also be on the USB stick.
- 5) Insert the USB stick into the USB socket on the Display Board.
- 6) Press and hold the center navigation key on the GPU to access the update function.
- 7) Press the center navigation key again to confirm the software update.
- 8) Wait for the software update to complete. Press the center navigation key when instructed to reset the Display Board.
- 9) If the software update does not complete, start over from step 4.

Verify the software is installed correctly.

- 1) Hold the center navigation key to access the menu on the Display Board.
- 2) Access the Parameter Info, and navigate up/down to the Unit Information page.
- 3) Verify that the display reports the expected software number and revision for both Display Board (Display FW) and Control Board (Control FW).

Operation Manual – ITW GSE 4400 Tier 3

Possible issues that may be encountered during this procedure:

- Error 201 "CRITICAL": Memory Error. Call Technician".
This is caused by the Control Board being unable to read the GPU configuration from the EEprom Board (P/N 579.533). The error should disappear after the configuration step. If the error persists even after configuring the GPU (remember to save), the EEprom Board may be defective.
- Error 250 "Update Failed". This is caused by an issue that may happen during the Display Board software update. Perform the software update again.
- The Setup Tool is unable to connect to the GPU. Using the Display Board menu, make sure the GPU Ethernet settings are set correctly. The correct settings are:
 - Ethernet mode: Manual
 - IP Address: 192.168.1.100
 - Subnet Mask: 255.255.255.0
 - Gateway: No significance
 - DNS 1: No significance
- The displays shows a "COMMUNICATION ERROR" screen.
This is caused by a failure in CAN-bus communication between the Control Board and the Display Board, usually because the Control Board is not programmed or has halted its execution. Check for faulty/un-programmed Control Board (flashing blue LED), and replace or program if necessary. Check that the cable from the Display Board to the Interface Board is fully seated at both ends, and try restarting the GPU. If the issue persists, try replacing the Control Board even if the blue LED is not flashing.
- The unit can't detect the USB stick or read any files on it. Reformat the USB stick using the below procedure and then copy the needed files back into the root folder.
 1. Insert the USB stick into a computers USB port.
 2. Open the File Explorer window and right click on the drive for the USB stick.
 3. select, 'Format...'

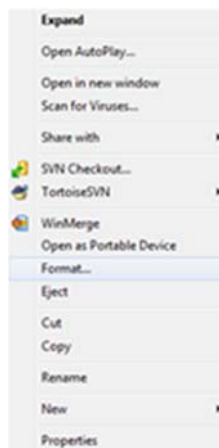

Operation Manual – ITW GSE 4400 Tier 3

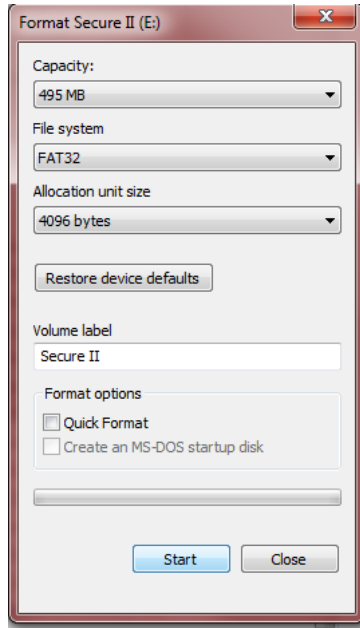

4. Set File system to FAT32 and make sure that Quick Format is NOT clicked. Press start.

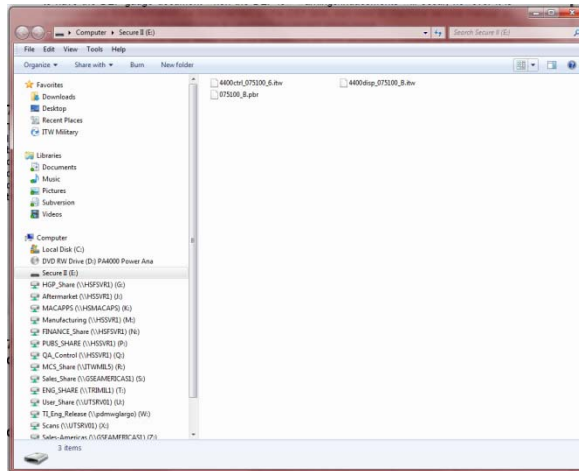

(The USB should function without issue after the format is complete. This may take several minutes to complete on larger drives.)

5. Copy the files into the root drive and it is ready.



Forward to Americas: ITW GSE Americas ☎ + 1 941 721 1092 ✉ support@itwgse.us International: ITW GSE ApS ☎ + 45 63 18 60 00 ✉ support@itwgse.com	Sender:	ITW GSE 4400 Information
	Company:	Model:
	Fax:	Serial No.:
	Phone:	Error Code:
	Contact:	Date:
	E-mail:	Time:

How to retrieve parameters from the Black Box :

1. Press centre button  hold it down for approximately 10 seconds to enter the Icon Menu.
2. To select Black Box, simply use the navigation keys ◀▼▲▶ to highlight the icon  Then press the ● to enter the menu
3. Use the ▼/▲ to highlight the failure you want to view
4. Press ● to select View information on the error. The error is then explained in clear text
5. Press ● to view detailed Alarm Data
6. Use the ▼/▲ to browse through the recorded data
7. Use ◀ to leave the submenu
8. Use ◀ to leave the submenu and return to basic Icon Menu

Output voltage:	A: V	B: V	C: V	Average: V
Output current:	A: A	B: A	C: A	Average: A
28VDC Output (option):	Voltage: V	Current: A	Ripple: V	Hour Meter:
Interlock 1 Level:	V	Ripple: V	ENGINE STATUS:	
Interlock 2 Level:	V	Ripple: -	-	V
Control DC Voltage:	V	Generator Duty Cycle:		
Engine RPM:	Oil Pressure:	Engine Temp:		
Engine Load:	Fuel Level:	DEF (T4):		
WARNINGS (Other indication (lamps, LED's, damages of enclosure etc.):				

NOTES:
 1. APPLICABLE DRAWING STANDARDS/SPECIFICATIONS:
 ASME Y14.5M, DIMENSIONS AND TOLERANCES.
 ASME Y14.100, ENGINEERING DRAWING PRACTICES.

PC1: INTERFACE BOARD

ID CHIP ON CONTROL BOX

Connector	Pin	Description	Connector	Pin	Description	Connector	Pin	Description	Connector	Pin	Description	Connector	Pin	Description		
X1	1	ECM (+)	X4	1	24VDC	X7	1	90% Switch TRU (-)	X12	1	90%Switch AC2 (-)	X40	1	Open		
	2	ECM (+)		2	GND		2	90% Switch TRU (+)		2	90%Switch AC2 (+)		2	CAN L	2	CAN L
	3	ECM (+)		3	J1939-L		3	Plug Temp TRU (-)		3	NCR AC2		3	GND	3	GND
	4	ECM (+)		4	J1939-H		4	Plug Temp TRU (+)		4	Plug Temp AC2 (-)		4	Open	4	Open
	5	ECM (-)	X5	1	Air Filter (-)	X8	1	5 Volts		X13	1		SPARES	5	Open	
	6	ECM (-)		2	Air Filter (+)		2	Fuel Level			2		SPARES	6	Open	
	7	ECM (-)		3	KeySwitch (Ignition)		3	Run Beacon	3	Exciter(+)	7		CAN H			
	8	ECM (-)		4	NOT USED		4	Low Fuel Beacon	4	Exciter(-)	8		Open			
X2	1	Current Shunt AC1 A (+)	X6	1	Interlock AC1	X9	1	Running Lights	X20	1	jumper only		X41	1	pin 5	
	2	Current Shunt AC1 A (-)		2	Interlock TRU		2	SpotLight		2	400 Hz A			2	pin 4	2
	3	Current Shunt AC1 B (+)		3	NOT USED		3	Output Contactor AC2 (-)		3	400 Hz B	3		pin 3	3	pin 3
	4	Current Shunt AC1 B (-)		4	NOT USED		4	Output Contactor AC2 (+)		4	400 Hz C	4		pin 2	4	pin 2
	5	Current Shunt AC1 C (+)		5	NOT USED		5	Output Contactor TRU (-)		5	400 Hz N	5		pin 1	5	pin 1
	6	Current Shunt AC1 C (-)		6	NOT USED		6	Output Contactor TRU (+)		6	NO Connection	6		pin 9	6	pin 9
	7	Interlock AC1		7	NOT USED		7	Interlock AC2		7	NO Connection	7		pin 8	7	pin 8
	8	NOT USED		8	NOT USED		8	Spotlight Gnd		8	NO Connection	8		pin 7	8	pin 7
	9	Output Contactor AC1 (-)		9	NOT USED		9	Output Contactor AC2 (-)		9	NO Connection	9		pin 6	9	pin 6
	10	Output Contactor AC1 (+)		10	NOT USED		10	Output Contactor AC2 (+)		10	NO Connection	10		GND (shell/shield)	10	GND (shell/shield)
X3	1	90%Switch AC1 (-)	X11	1	Interlock AC2	X10	1	NO Connection	X21	1	400 Hz A	X42	1	POWER TO ARU BLACK/RED		
	2	90%Switch AC1 (+)		2	Spotlight Gnd		2	NO Connection		2	400 Hz B		2	pin 4	2	pin 4
	3	NCR AC1		3	Interlock TRU		3	NO Connection		3	400 Hz C		3	pin 3	3	pin 3
	4	Plug Temp AC1 (-)		4	NOT USED		4	NO Connection		4	400 Hz N		4	pin 2	4	pin 2
	5	Plug Temp AC1 (+)		5	NOT USED		5	ID Chip		5	NO Connection		5	pin 1	5	pin 1
	6	Open		6	NOT USED		6	ARU Connections		6	NO Connection		6	pin 9	6	pin 9

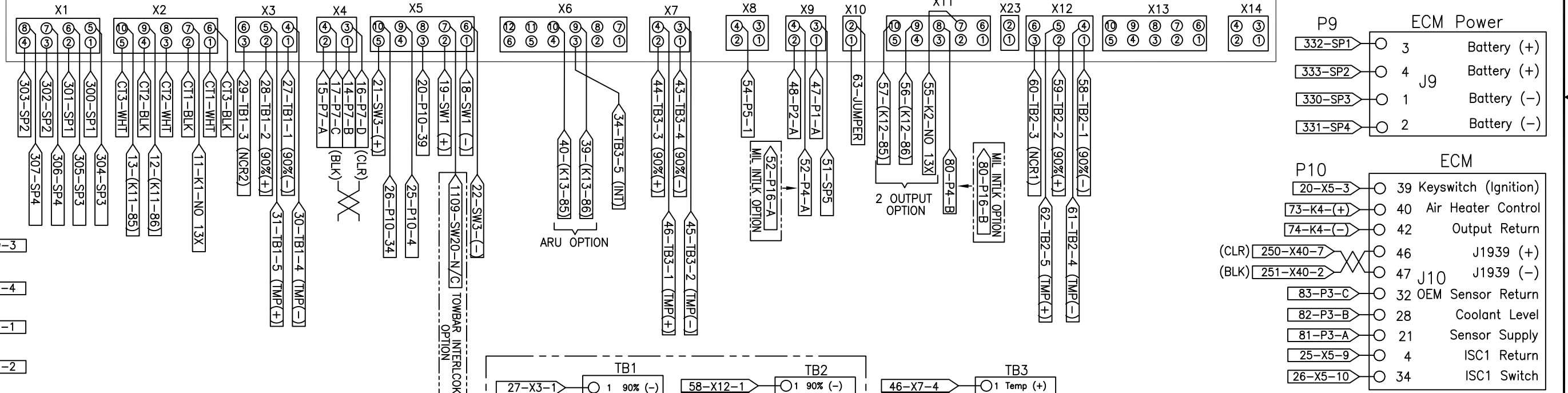

Wire Number	AWG	mm2	Notes
1-15,18-249	18	0.75	
16,17/250,251	18	0.75	(Twisted PR)
252 to 265	18	0.75	
266 to 329	16	1.5	
330 to 349	12	4	
350 to 399	10	6	
400 to 449	8	10	
450 to 499	6	16	
500 to 599	4	25	
600 to 699	2	35	
700 to 799	1/0	50	
800 to 899	2/0	70	
900	12	4	GREEN W/YEL STRIPE
1100 to 1199	18	0.75	(THIN WALL)

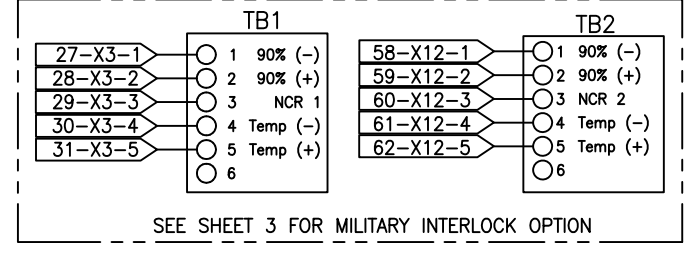
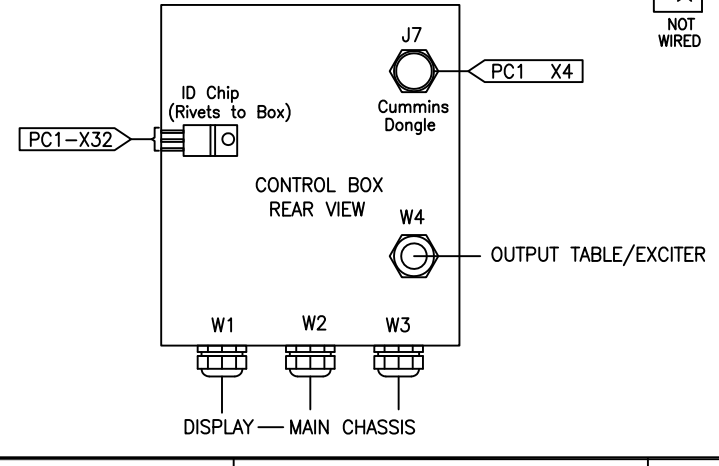

ITW GSE, DIV. GSE HOLDINGS INC. CAGE: 12867
 11001 US HIGHWAY 41 NORTH, PALMETTO, FL 34221
 THIS DATA IS LICENSED, CONFIDENTIAL AND OR PROPRIETARY TO ITW GSE.
 NEITHER THIS DOCUMENT NOR DATA NOR THE INFORMATION CONTAINED HEREIN IS TO BE USED,
 MODIFIED, REPRODUCED, RELEASED, PERFORMED, DISPLAYED, OR DISCLOSED, EITHER IN PART OR
 IN WHOLE, EXCEPT AS SPECIFICALLY AUTHORIZED BY ITW GSE. IF YOU HAVE BEEN
 PROVIDED ACCESS TO THIS DATA YOU MUST PROMPTLY NOTIFY THE ABOVE.

MATERIAL:	CONTRACT NO.	UNLESS OTHERWISE SPECIFIED: DIMENSIONS ARE IN INCHES TOLERANCES ON: FRACTIONS DECIMALS ANGLES ± 1/32 .XX ± .03 ± .50 .XXX ± .015	
DRAWN R. LAWTER 06-25-13		ITW GSE 11001 US Highway 41 North, Palmetto, FL 34221	
CHECKED G. ELWELL 06-25-13		SCHEMATIC, ENGINE DRIVE (4400 Tier 3)	
ENGINEER R. LAWTER 06/25/13	APPROVED M. JEWELL 06/25/13	SIZE D	CAGE 12867
FILE NO. 293145_1	NEXT ASSY. USED ON APPLICATION	DRAWING NO. 293145	REV. E
THIRD ANGLE PROJECTION		SCALE	WEIGHT

Page 122 of 124

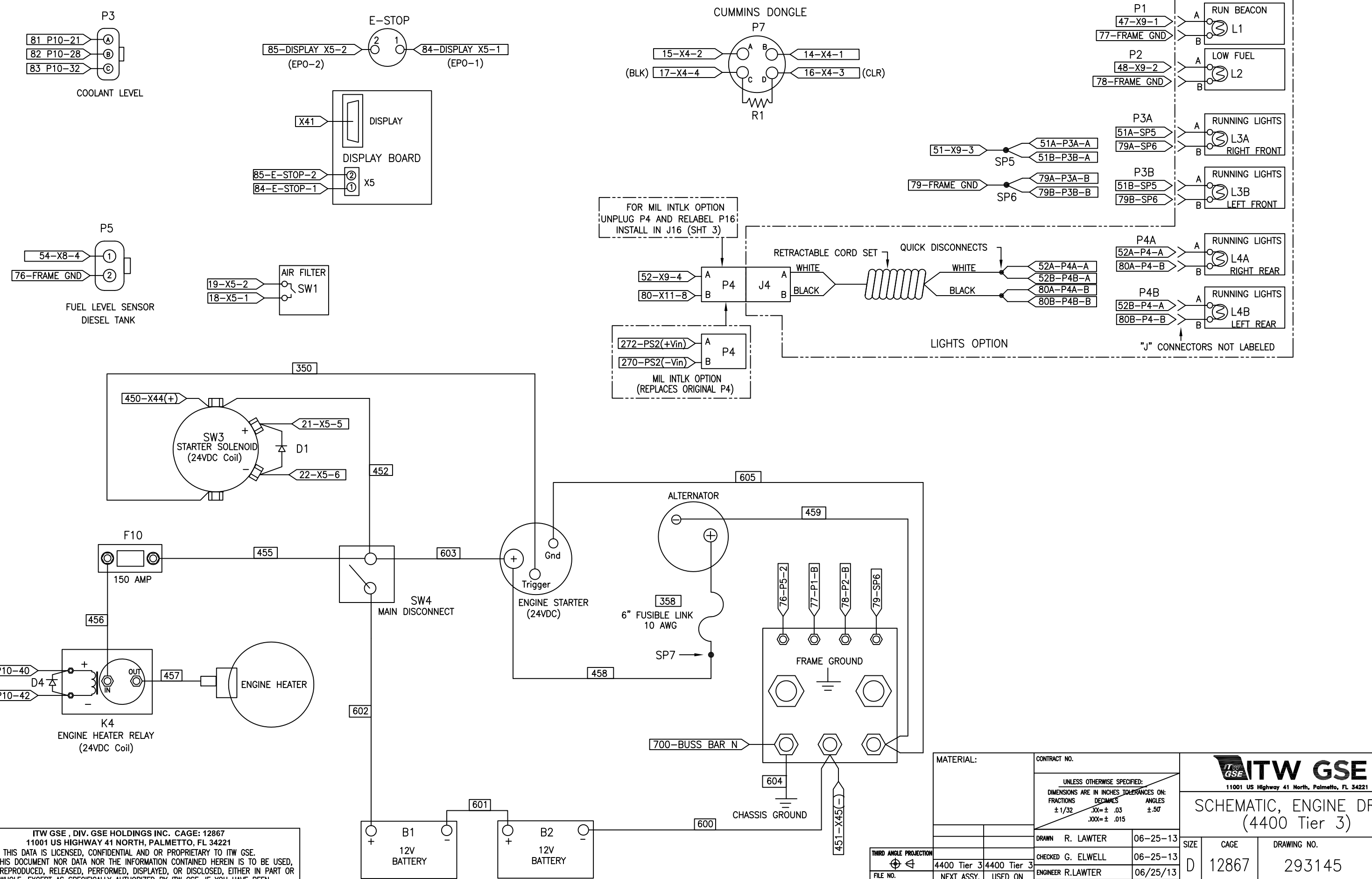

ITW GSE, DIV. GSE HOLDINGS INC. CAGE: 12867
 11001 US HIGHWAY 41 NORTH, PALMETTO, FL 34221
 THIS DATA IS LICENSED, CONFIDENTIAL AND OR PROPRIETARY TO ITW GSE.
 NEITHER THIS DOCUMENT NOR DATA NOR THE INFORMATION CONTAINED HEREIN IS TO BE USED,
 MODIFIED, REPRODUCED, RELEASED, PERFORMED, DISPLAYED, OR DISCLOSED, EITHER IN PART OR
 IN WHOLE, EXCEPT AS SPECIFICALLY AUTHORIZED BY ITW GSE. IF YOU HAVE BEEN
 PROVIDED WITH THIS DATA YOU MUST PROMPTLY NOTIFY THE ABOVE.

MATERIAL:		CONTRACT NO.		 11001 US Highway 41 North, Palmetto, FL 34221			
UNLESS OTHERWISE SPECIFIED: DIMENSIONS ARE IN INCHES TOLERANCES ON: FRACTIONS DECIMALS ANGLES ±1/32 .XX±.03 ±.50 .XXX±.015						SCHEMATIC, ENGINE DRIVE (4400 Tier 3)	
DRAWN R. LAWTER		06-25-13		SIZE	CAGE	DRAWING NO.	REV.
CHECKED G. ELWELL		06-25-13		D	12867	293145	E
ENGINEER R. LAWTER		06/25/13		SCALE WEIGHT Page 123 of SHEET 2 OF 3			
APPROVED M. JEWELL		06/25/13					

ITW GSE, DIV. GSE HOLDINGS INC. CAGE: 12867
 11001 US HIGHWAY 41 NORTH, PALMETTO, FL 34221
 THIS DATA IS LICENSED, CONFIDENTIAL AND OR PROPRIETARY TO ITW GSE.
 NEITHER THIS DOCUMENT NOR DATA NOR THE INFORMATION CONTAINED HEREIN IS TO BE USED,
 MODIFIED, REPRODUCED, RELEASED, PERFORMED, DISPLAYED, OR DISCLOSED, EITHER IN PART OR
 IN WHOLE, EXCEPT AS SPECIFICALLY AUTHORIZED BY ITW GSE. IF YOU HAVE BEEN
 PROVIDED ACCESS TO THIS DATA YOU MUST PROMPTLY NOTIFY THE ABOVE.

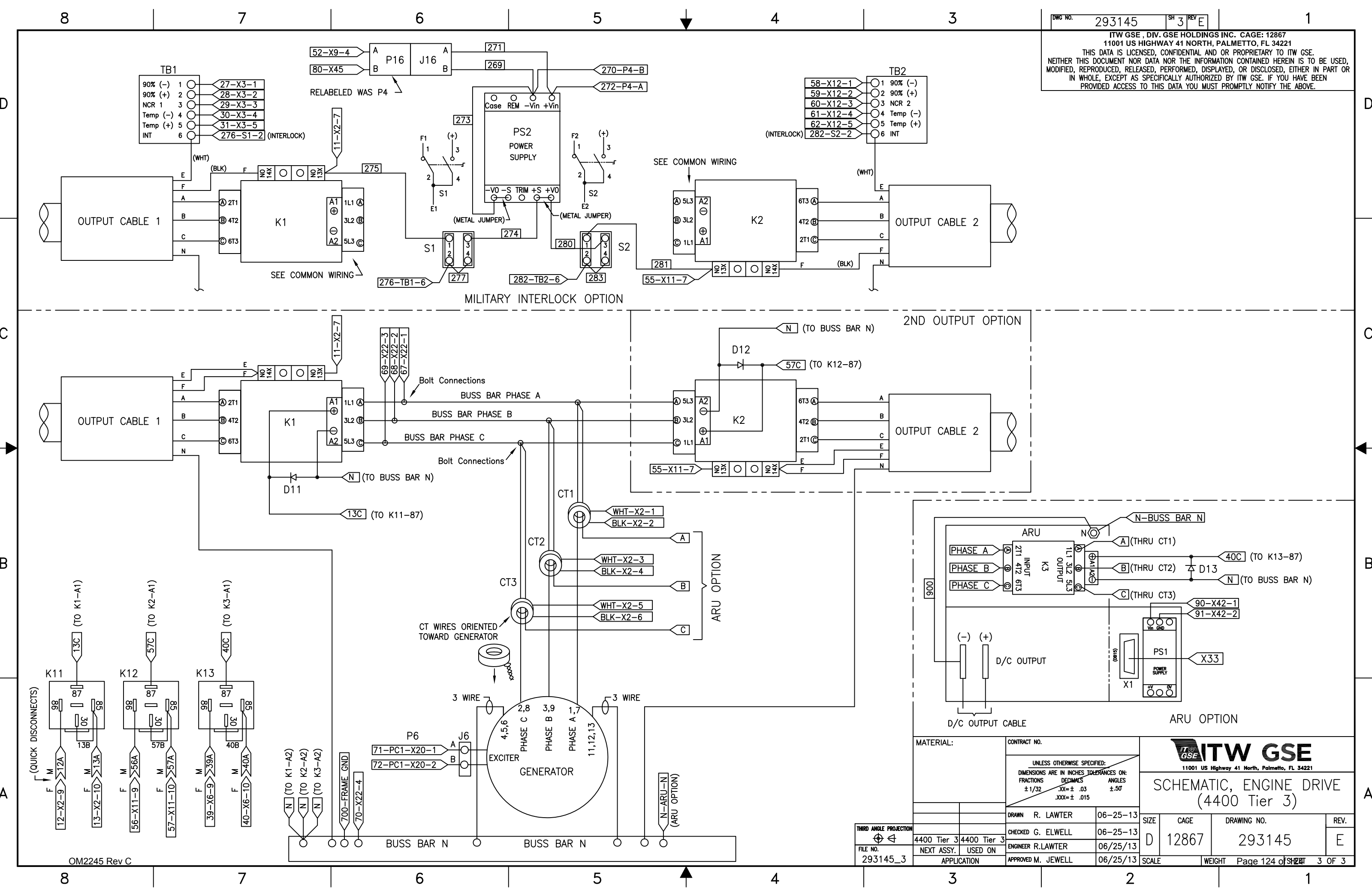

MATERIAL:		CONTRACT NO.		 11001 US Highway 41 North, Palmetto, FL 34221	
UNLESS OTHERWISE SPECIFIED: DIMENSIONS ARE IN INCHES TOLERANCES ON: FRACTIONS DECIMALS ANGLES ±1/32 .XX±.03 ±.50 .XXX±.015					
THIRD ANGLE PROJECTION	4400 Tier 3	4400 Tier 3	DRAWN R. LAWTER	06-25-13	SIZE D CAGE 12867 DRAWING NO. 293145 REV. E
FILE NO. 293145_3	NEXT ASSY. USED ON	APPLICATION	CHECKED G. ELWELL	06-25-13	
			ENGINEER R. LAWTER	06/25/13	SCALE WEIGHT Page 124 of SHEET 3 OF 3
			APPROVED M. JEWELL	06/25/13	

SCHEMATIC, ENGINE DRIVE (4400 Tier 3)