

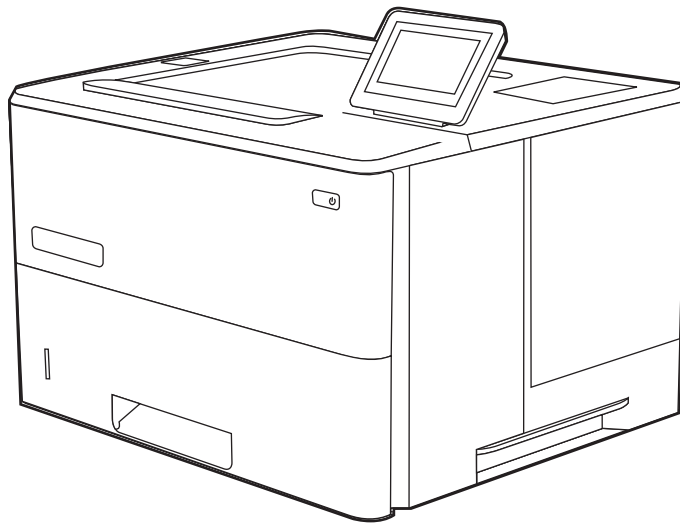

LaserJet Managed E50145

User Guide



www.hp.com/videos/LaserJet
www.hp.com/support/ljE50145



HP LaserJet Managed E50145

User Guide

Copyright and License

© Copyright 2019 HP Development Company, L.P.

Reproduction, adaptation, or translation without prior written permission is prohibited, except as allowed under the copyright laws.

The information contained herein is subject to change without notice.

The only warranties for HP products and services are set forth in the express warranty statements accompanying such products and services. Nothing herein should be construed as constituting an additional warranty. HP shall not be liable for technical or editorial errors or omissions contained herein.

Edition 1, 4/2019

Trademark Credits

Adobe®, Adobe Photoshop®, Acrobat®, and PostScript® are trademarks of Adobe Systems Incorporated.

Apple and the Apple logo are trademarks of Apple Inc., registered in the U.S. and other countries.

macOS is a trademark of Apple Inc., registered in the U.S. and other countries.

AirPrint is a trademark of Apple Inc., registered in the U.S. and other countries.

Google™ is a trademark of Google Inc.

Microsoft®, Windows®, Windows® XP, and Windows Vista® are U.S. registered trademarks of Microsoft Corporation.

UNIX® is a registered trademark of The Open Group.

Table of contents

1 Printer overview	1
Warning icons	1
Potential shock hazard	3
Printer views	4
Printer front view	4
Printer back view	5
Interface ports	5
Control-panel view	7
How to use the touchscreen control panel	8
Printer specifications	10
Technical specifications	10
Supported operating systems	11
Printer dimensions	13
Power consumption, electrical specifications, and acoustic emissions	13
Operating-environment range	14
Printer hardware setup and software installation	14
2 Paper trays	15
Introduction	15
Load paper to Tray 1	16
Load paper to Tray 1 (multipurpose tray)	16
Tray 1 paper orientation	17
Use alternative letterhead mode	18
Enable Alternative Letterhead Mode by using the printer control-panel menus	18
Load paper to Tray 2 and the 550-sheet trays	19
Load paper to Tray 2 and the 550-sheet trays	19
Tray 2 and the 550-sheet trays paper orientation	21
Use alternative letterhead mode	18
Enable Alternative Letterhead Mode by using the printer control-panel menus	18
Load and print envelopes	23
Print envelopes	23
Envelope orientation	23

Load and print labels	24
Manually feed labels	24
Label orientation	24
3 Supplies, accessories, and parts	25
Order supplies, accessories, and parts	26
Ordering	26
Supplies and accessories	26
Customer self-repair parts	26
Replace the toner cartridge	28
Cartridge information	28
Remove and replace the cartridge	29
4 Print	33
Print tasks (Windows)	34
How to print (Windows)	34
Automatically print on both sides (Windows)	34
Manually print on both sides (Windows)	35
Print multiple pages per sheet (Windows)	35
Select the paper type (Windows)	36
Additional print tasks	37
Print tasks (macOS)	38
How to print (macOS)	38
Automatically print on both sides (macOS)	38
Manually print on both sides (macOS)	38
Print multiple pages per sheet (macOS)	39
Select the paper type (macOS)	39
Additional print tasks	37
Store print jobs on the printer to print later or print privately	41
Introduction	41
Create a stored job (Windows)	41
Create a stored job (macOS)	42
Print a stored job	43
Delete a stored job	44
Delete a job that is stored on the printer	44
Change the job storage limit	44
Information sent to printer for Job Accounting purposes	44
Print from a USB flash drive	45
Enable the USB port for printing	46
Method one: Enable the USB port from the printer control panel	46

Method two: Enable the USB port from the HP Embedded Web Server (network-connected printers only)	46
Print USB documents	46
Print using high-speed USB 2.0 port (wired)	48
Enable the high-speed USB port for printing	49
Method one: Enable the high-speed USB 2.0 port from the printer control panel menus	49
Method two: Enable the high-speed USB 2.0 port from the HP Embedded Web Server (network-connected printers only)	49
5 Manage the printer	51
Advanced configuration with the HP Embedded Web Server (EWS)	52
Introduction	52
How to access the HP Embedded Web Server (EWS)	52
HP Embedded Web Server features	54
Information tab	54
General tab	54
Print tab	55
Supplies tab	56
Troubleshooting tab	56
Security tab	56
HP Web Services tab	57
Networking tab	57
Other Links list	59
Configure IP network settings	60
Printer sharing disclaimer	60
View or change network settings	60
Rename the printer on a network	60
Manually configure IPv4 TCP/IP parameters from the control panel	61
Manually configure IPv6 TCP/IP parameters from the control panel	61
Link speed and duplex settings	62
Printer security features	63
Introduction	63
Security statements	63
Assign an administrator password	64
Use the HP Embedded Web Server (EWS) to set the password	64
Provide user access credentials at the printer control panel	64
IP Security	65
Encryption support: HP High Performance Secure Hard Disks	65
Lock the formatter	65
Energy-conservation settings	66

Print with EconoMode	67
Configure EconoMode from the print driver	67
Configure EconoMode from the printer control panel	67
Set the sleep timer and configure the printer to use 1 watt or less of power	67
HP Web Jetadmin	68
Software and firmware updates	68

6 Solve problems 69

Customer support	69
Control panel help system	70
Reset factory settings	71
Introduction	71
Method one: Reset factory settings from the printer control panel	71
Method two: Reset factory settings from the HP Embedded Web Server (network-connected printers only)	71
A “Cartridge is low” or “Cartridge is very low” message displays on the printer control panel	72
Printer does not pick up paper or misfeeds	73
Introduction	73
The printer does not pick up paper	73
The printer picks up multiple sheets of paper	75
Clear paper jams	79
Introduction	79
Paper jam locations	79
Auto-navigation for clearing paper jams	80
Experiencing frequent or recurring paper jams?	80
Clear paper jams in tray 1—13.A1	80
Clear paper jams in tray 2, tray 3, tray 4, tray 5—13.A2, 13.A3, 13.A4, 13.A5	83
Clear paper jams in the output bin—13.E1	86
Clear paper jams in the duplexer—13.CX.XX, 13.DX.XX	87
Clear paper jams in the toner-cartridge area	91
Clear paper jams in the fuser—13.B9, 13.B2, 13.FF	93
Resolve print-quality problems	95
Introduction	95
Troubleshoot print quality	96
Print from a different software program	96
Check the paper-type setting for the print job	97
Check the paper type setting on the printer	97
Check the paper type setting (Windows)	97
Check the paper type setting (macOS)	97
Check toner-cartridge status	98
Step one: Print the supplies status page	98

Step two: Check supplies status	98
Print a cleaning page	98
Visually inspect the toner cartridge or cartridges	99
Check paper and the printing environment	100
Step one: Use paper that meets HP specifications	100
Step two: Check the environment	100
Step three: Set the individual tray alignment	100
Try a different print driver	101
Troubleshoot image defects	101

Index	111
-------------	-----

1 Printer overview

Review the location of features on the printer, the physical and technical specifications of the printer, and where to locate setup information.

- [Warning icons](#)
- [Potential shock hazard](#)
- [Printer views](#)
- [Printer specifications](#)
- [Printer hardware setup and software installation](#)

For video assistance, see www.hp.com/videos/LaserJet.

The following information is correct at the time of publication. For current information, see <http://www.hp.com/support/ljE50145>.

For more information:

HP's all-inclusive help for the printer includes the following information:

- Install and configure
- Learn and use
- Solve problems
- Download software and firmware updates
- Join support forums
- Find warranty and regulatory information

Warning icons

Use caution if you see a warning icon on your HP printer, as indicated in the icon definitions.

- Caution: Electric shock



- Caution: Hot surface



- Caution: Keep body parts away from moving parts



- Caution: Sharp edge in close proximity



- Warning



Potential shock hazard

Review this important safety information.

- Read and understand these safety statements to avoid an electrical shock hazard.
- Always follow basic safety precautions when using this product to reduce risk of injury from fire or electric shock.
- Read and understand all instructions in the user guide.

Observe all warnings and instructions marked on the product.

- Use only a grounded electrical outlet when connecting the product to a power source. If you do not know whether the outlet is grounded, check with a qualified electrician.
- Do not touch the contacts on any of the sockets on the product. Replace damaged cords immediately.
- Unplug this product from wall outlets before cleaning.
- Do not install or use this product near water or when you are wet.
- Install the product securely on a stable surface.
- Install the product in a protected location where no one can step on or trip over the power cord.

Printer views

Identify certain parts of the printer and the control panel.

- [Printer front view](#)
- [Printer back view](#)
- [Interface ports](#)
- [Control-panel view](#)

Printer front view

Use the diagram to locate important components on the printer.

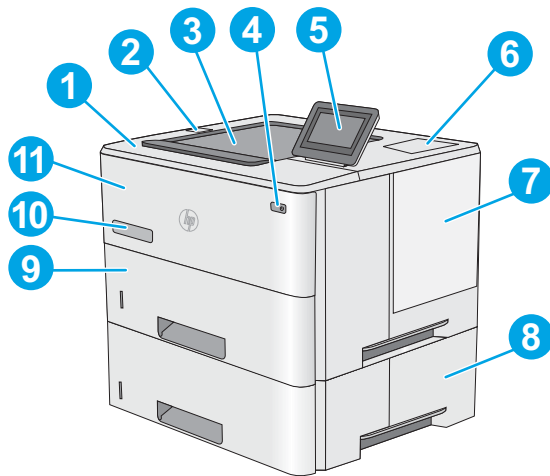

1	Top cover (access to the toner cartridge)
2	Easy-access USB port Insert a USB flash drive for printing without a computer or to update the printer firmware. NOTE: An administrator must enable this port before use.
3	Output bin
4	On/off button
5	Control panel with color touchscreen display
6	Hardware integration pocket for connecting accessory and third-party devices NOTE: To use the hardware integration pocket (HIP), install the HP internal USB ports accessory (B5L28A). The USB port inside the HIP is not functional otherwise.
7	Formatter cover
8	Optional 1 x 550-sheet paper feeder, Tray 3 NOTE: Each printer model accepts up to three optional 1 x 550-sheet feeders (Trays 3, 4, and 5).
9	Tray 2
10	Model name
11	Tray 1

Printer back view

Use the diagram to locate important components on the printer.

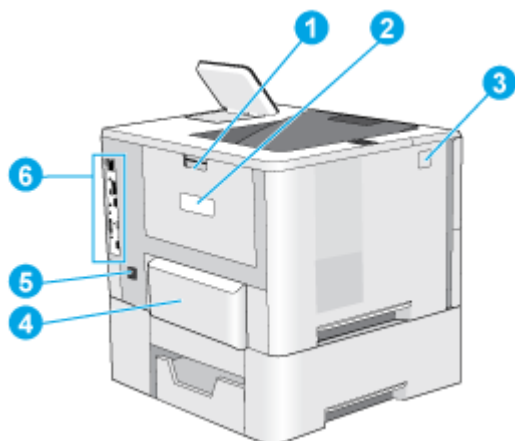

1	Rear door (access for clearing jams)
2	Serial number and product number label
3	Top-cover-release button
4	Dust cover for Tray 2 (flips up when legal-size paper is loaded)
5	Power connection
6	Formatter (contains the interface ports)

Interface ports

Use the diagram to identify the printer interface ports.

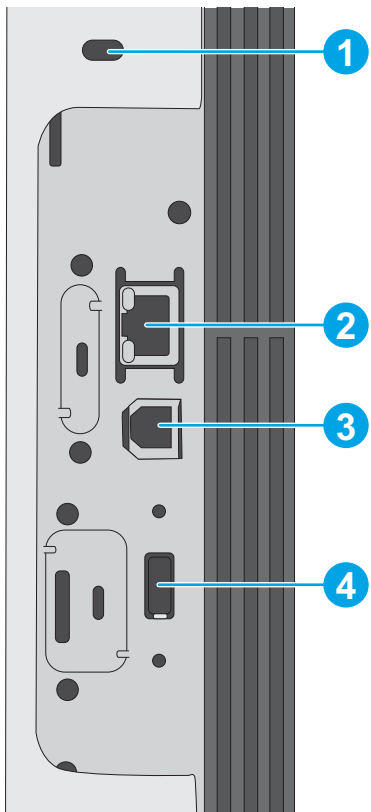

-
- 1 Slot for a cable-type security lock

 - 2 Local area network (LAN) Ethernet 10/100/1000 network port

 - 3 Hi-Speed USB 2.0 printing port

 - 4 USB port for connecting external USB devices (this port might be covered)

NOTE: For easy-access USB printing, use the USB port near the control panel.

Control-panel view

Use the touchscreen control panel to obtain printer and job status information and to configure the printer.

- [How to use the touchscreen control panel](#)

 **NOTE:** Tilt the control panel for easier viewing.

Return to the Home screen at any time by selecting the Home  button at the bottom of the printer control panel.



 **NOTE:** For more information about the printer-control-panel features, go to <http://www.hp.com/support/ijE50145>. Select **Manuals**, and then select **General reference**.

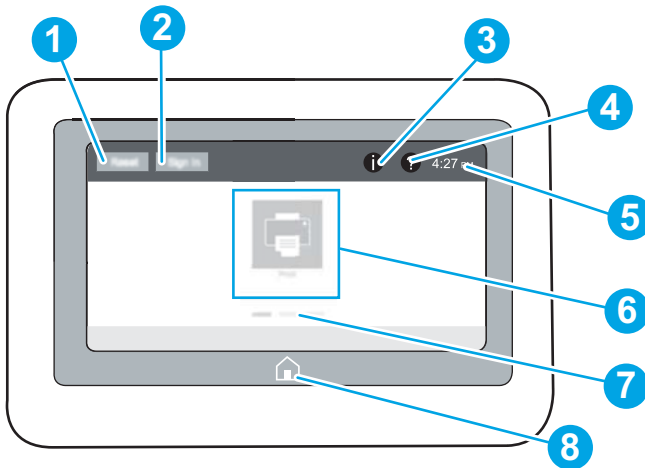



 **NOTE:** The features that appear on the Home screen can vary, depending on the printer configuration.



- | | | |
|---|--|---|
| 1 | Reset button | Select the Reset button to clear changes, release the printer from a paused state, display hidden errors, and restore the default settings (including the language and keyboard layout). |
| 2 | Sign In or Sign Out button | Select the Sign In button to open the Sign In screen.

Select the Sign Out button to sign out of the printer. The printer restores all options to the default settings.

NOTE: This button displays only if the administrator has configured the printer to require permission for access to features. |
| 3 | Information  button | Select the Information  button to access a screen that provides access to several types of printer information. Select the buttons at the bottom of the screen for the following information: <ul style="list-style-type: none">• Display Language: Change the language setting for the current user session.• Sleep Mode: Place the printer into sleep mode.• Wi-Fi Direct: View information for how to connect directly to the printer using a phone, tablet, or other device with Wi-Fi.• Wireless: View or change wireless connection settings (some models require an optional wireless accessory).• Ethernet: View or change Ethernet connection settings.• HP Web Services: View information to connect and print to the printer using HP Web Services (ePrint). |

4	Help  button	Select the Help  button to open the embedded help system. The system provides a list of help topics or information about a topic when using the Home screen, an app, an option, or a feature.
5	Current time	Displays the current time.
6	Applications area	Select any of the icons to open the application. Swipe the screen sideways to access more applications. NOTE: The available applications vary by printer. The administrator can configure which applications appear and the order in which they appear.
7	Home-screen page indicator	Indicates the number of pages on the Home screen or in an application. The current page is highlighted. Swipe the screen sideways to scroll between pages.
8	Home  button	Select the Home  button to return to the Home screen.

How to use the touchscreen control panel

Use the following actions to use the printer touchscreen control panel.

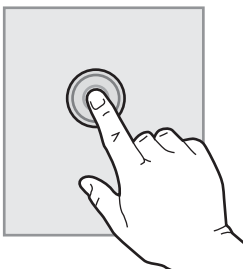
Action	Description	Example
<p>Touch</p> 	Touch an item on the screen to select that item or open that menu. Also, when scrolling through menus, briefly touch the screen to stop the scrolling.	Touch the Settings icon to open the Settings app.

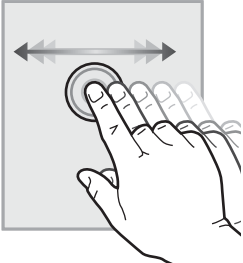
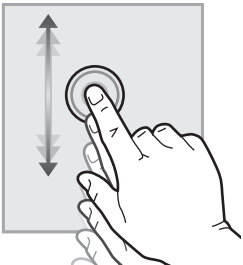
Action	Description	Example
Swipe	Touch the screen and then move your finger horizontally to scroll the screen sideways.	Swipe until the Settings app displays.
		
Scroll	Touch the screen and then move your finger vertically to scroll the screen up and down. When scrolling through menus, briefly touch the screen to stop the scrolling.	Scroll through the Settings app.
		

Printer specifications

Use the printer specifications to set up and operate the printer.

- [Technical specifications](#)
- [Supported operating systems](#)
- [Printer dimensions](#)
- [Power consumption, electrical specifications, and acoustic emissions](#)
- [Operating-environment range](#)



IMPORTANT: The following specifications are correct at the time of publication, but they are subject to change. For current information, see <http://www.hp.com/support/ljE50145>.

Technical specifications

Model name		E50145dn
Product number		1PU51A
Paper handling	Tray 1 (100-sheet capacity)	Included
	Tray 2 (550-sheet capacity)	Included
	Tray 3 (550-sheet capacity)	Optional
	NOTE: The printer is limited to a total of five input trays, including combination of MP tray, main cassette, and stackable, 2,300 pages max. input.	
	Automatic duplex printing	Included
Connectivity	10/100/1000 Ethernet LAN connection with IPv4 and IPv6	Included
	Hi-Speed USB 2.0	Included
	Print server for wireless network connectivity	Optional
	Walk-up USB port	Included
	Hardware Integration Pocket for connecting accessory and third-party devices	Optional
	Bluetooth Low Energy (BLE) for printing from mobile devices	Not available
	HP Internal USB Ports	Optional
	HP Jetdirect 3100w BLE/NFC/Wireless Accessory	Optional
	HP Jetdirect 2900nw Print Server accessory for wireless connectivity	Optional
Memory	1 GB base memory	Included
	NOTE: The base memory is expandable to 2 GB by adding a DIMM memory module.	
Mass storage	Encrypted FIPS HDD	Optional

Model name		E50145dn
Product number		1PU51A
Security	HP Trusted Platform Module for encrypting all data that passes through the printer	Included
Control-panel display and input	Color touchscreen control panel	Included
Print	Prints 45 pages per minute (ppm) on A4 and letter-size paper	Included
	USB printing	Included
	Mobile/cloud printing	Not available
	Store jobs in the printer memory to print later or print privately	Not available
	(Requires a 16 GB or greater USB thumb drive.)	

Supported operating systems

Use the following information to ensure printer compatibility with your computer operating system.

Linux: For information and print drivers for Linux, go to www.hp.com/go/linuxprinting.

UNIX: For information and print drivers for UNIX®, go to www.hp.com/go/unixmodelscripts.

The following information applies to the printer-specific Windows HP PCL 6 print drivers, HP print drivers for macOS, and to the software installer.

Windows: Download HP Easy Start from 123.hp.com/LaserJet to install the HP print driver. Or, go to the printer-support website for this printer, <http://www.hp.com/support/ljE50145>, to download the print driver or the software installer to install the HP print driver

macOS: Mac computers are supported with this printer. Download HP Easy Start either from 123.hp.com/LaserJet or from the Printer Support page, and then use HP Easy Start to install the HP print driver.

1. Go to 123.hp.com/LaserJet.
2. Follow the steps provided to download the printer software.

Table 1-1 Supported operating systems and print drivers

Operating system	Print driver installed (for Windows, or the installer on the web for macOS)	Notes
Windows 7, 32-bit and 64-bit	The "HP PCL 6" printer-specific print driver is installed for this operating system as part of the software installation.	
Windows 8, 32-bit and 64-bit	The "HP PCL 6" printer-specific print driver is installed for this operating system as part of the software installation.	Windows 8 RT support is provided through Microsoft IN OS Version 4, 32-bit driver.
Windows 8.1, 32-bit and 64-bit	The "HP PCL-6" V4 printer-specific print driver is installed for this operating system as part of the software installation.	Windows 8.1 RT support is provided through Microsoft IN OS Version 4, 32-bit driver.

Table 1-1 Supported operating systems and print drivers (continued)

Operating system	Print driver installed (for Windows, or the installer on the web for macOS)	Notes
Windows 10, 32-bit and 64-bit	The "HP PCL-6" V4 printer-specific print driver is installed for this operating system as part of the software installation.	
Windows Server 2008 R2, SP 1, 64-bit	The PCL 6 printer-specific print driver is available for download from the printer-support website. Download the driver, and then use the Microsoft Add Printer tool to install it.	
Windows Server 2012, 64-bit	The PCL 6 printer-specific print driver is available for download from the printer-support website. Download the driver, and then use the Microsoft Add Printer tool to install it.	
Windows Server 2012 R2, 64-bit	The PCL 6 printer-specific print driver is available for download from the printer-support website. Download the driver, and then use the Microsoft Add Printer tool to install it.	
Windows Server 2016, 64-bit	The PCL 6 printer-specific print driver is available for download from the printer-support website. Download the driver, and then use the Microsoft Add Printer tool to install it.	
macOS 10.12 Sierra, macOS 10.13 High Sierra	Download HP Easy Start from 123.hp.com/LaserJet , and then use it to install the print driver.	

 **NOTE:** Supported operating systems can change. For a current list of supported operating systems, go to <http://www.hp.com/support/ljE50145> for HP's all-inclusive help for the printer.



 **NOTE:** For details on client and server operating systems and for HP UPD driver support for this printer, go to www.hp.com/go/upd. Under **Additional information**, click the links.

Table 1-2 Minimum system requirements

Windows	macOS
<ul style="list-style-type: none"> • Internet connection 	<ul style="list-style-type: none"> • Internet connection
<ul style="list-style-type: none"> • Dedicated USB 1.1 or 2.0 connection or a network connection 	<ul style="list-style-type: none"> • Dedicated USB 1.1 or 2.0 connection or a network connection
<ul style="list-style-type: none"> • 2 GB of available hard-disk space 	<ul style="list-style-type: none"> • 1.5 GB of available hard-disk space
<ul style="list-style-type: none"> • 1 GB RAM (32-bit) or 2 GB RAM (64-bit) 	

 **NOTE:** The Windows software installer installs the HP Smart Device Agent Base service. The file size is approximately 100 kb. Its only function is to check for printers connected via USB hourly. No data is collected. If a USB printer is found, it then tries to locate a JetAdvantage Management Connector (JAMc) instance on the network. If a JAMc is found, the HP Smart Device Agent Base is securely upgraded to a full Smart Device Agent from JAMc, which will then allow printed pages to be accounted for in a Managed Print Services (MPS) account. The driver-only web packs downloaded from hp.com for the printer and installed through the Add Printer wizard do not install this service.

To uninstall the service, open the Windows Control Panel, select **Programs** or **Programs and Features**, and then select **Add/Remove Programs** or **Uninstall a Program** to remove the service. The file name is **HPSmartDeviceAgentBase**.

Printer dimensions

Table 1-3 Dimensions for the base printer

	Printer fully closed	Printer fully opened
Height	296 mm (11.7 in)	296 mm (11.7 in)
Depth	Tray 2 dust cover closed: 376 mm (14.8 in) Tray 2 dust cover open: 444 mm (17.5 in)	569 mm (22.4 in)
Width	410 mm (16.1 in)	410 mm (16.1 in)
Weight	12 kg (26.5 lb)	

Table 1-4 Dimensions for the 1 x 550-sheet paper feeder

Height	130 mm (5.1 in)
Depth	Tray closed: 376 mm (14.8 in) Tray opened: 569 mm (22.4 in)
Width	410 mm (16.1 in)
Weight	1.4 kg (3 lb)

Table 1-5 Dimensions for the printer cabinet

Height	381 mm (15 in)
Depth	Door closed: 632 mm (24.9 in) Door opened and rear castors rotated: 865 mm (34 in)
Width	Door closed: 600 mm (23.6 in) Door opened and rear castors rotated: 630 mm (24.8 in)
Weight	9 kg (20 lb)

Power consumption, electrical specifications, and acoustic emissions

See <http://www.hp.com/support/ljE50145> for current information.

⚠ CAUTION: Power requirements are based on the country/region where the printer is sold. Do not convert operating voltages. This will damage the printer and void the printer warranty.

Operating-environment range

Table 1-6 Operating-environment specifications

Environment	Recommended	Allowed
Temperature	17° to 25°C (62.6° to 77°F)	15° to 30°C (59° to 86°F)
Relative humidity	30% to 70% relative humidity (RH)	10% to 80% RH

Printer hardware setup and software installation

For basic setup instructions, see the Hardware Installation Guide that came with the printer. For additional instructions, go to HP support on the web.

Go to <http://www.hp.com/support/ljE50145> for HP's all-inclusive help for the printer. Find the following support:

- Install and configure
- Learn and use
- Solve problems
- Download software and firmware updates
- Join support forums
- Find warranty and regulatory information

2 Paper trays

Discover how to load and use the paper trays, including how to load special items such as envelopes and labels.

- [Introduction](#)
- [Load paper to Tray 1](#)
- [Load paper to Tray 2 and the 550-sheet trays](#)
- [Load and print envelopes](#)
- [Load and print labels](#)

For video assistance, see www.hp.com/videos/LaserJet.

The following information is correct at the time of publication. For current information, see <http://www.hp.com/support/ljE50145>.

For more information:

HP's all-inclusive help for the printer includes the following information:

- Install and configure
- Learn and use
- Solve problems
- Download software and firmware updates
- Join support forums
- Find warranty and regulatory information

Introduction

Use caution when loading the paper trays.

 **CAUTION:** Do not extend more than one paper tray at a time.

Do not use paper tray as a step.

Keep hands out of paper trays when closing.

All trays must be closed when moving the printer.

Load paper to Tray 1

The following information describes how to load paper into Tray 1.

- [Load paper to Tray 1 \(multipurpose tray\)](#)
- [Tray 1 paper orientation](#)
- [Use alternative letterhead mode](#)

Load paper to Tray 1 (multipurpose tray)

This tray holds up to 100 sheets of 75 g/m² (20 lb) paper or 10 envelopes.

 **NOTE:** Select the correct paper type in the print driver before printing.

 **CAUTION:** To avoid jams, never add or remove paper from Tray 1 during printing.

1. Grasp the handle on either side of Tray 1, and pull it forward to open it.

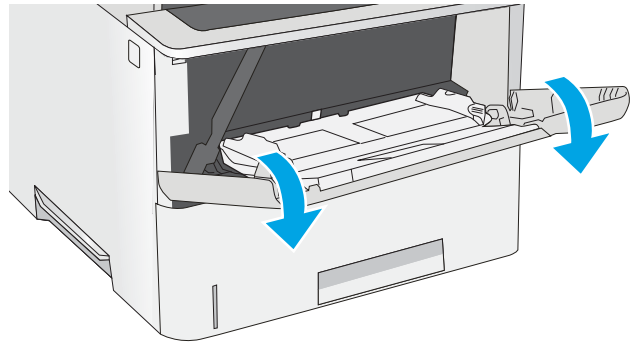

2. Pull out the tray extension to support the paper.

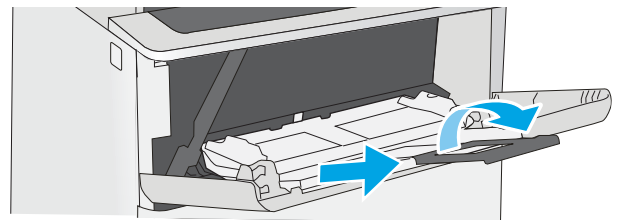

- Spread the paper guides to the correct size, and then load paper in the tray. For information about how to orient the paper, see [Tray 1 paper orientation on page 17](#).

Make sure that the paper fits under the fill line on the paper guides.

NOTE: The maximum stack height is 10 mm (0.4 in), or approximately 100 sheets of 75 g/m² (20 lb) paper.

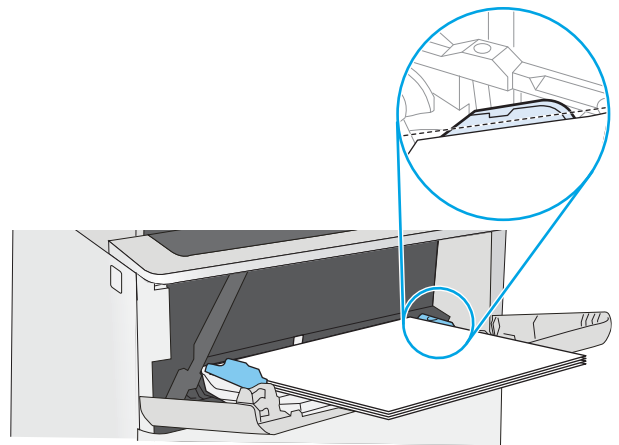

- Adjust the side guides so that they lightly touch the paper stack, but do not bend it.

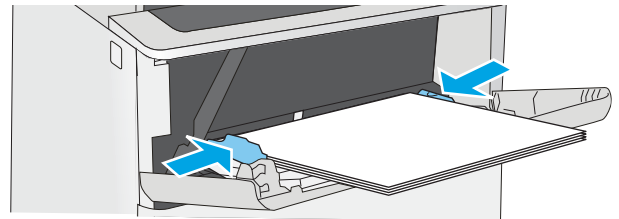

Tray 1 paper orientation

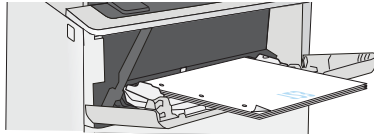
Paper type	Single-sided printing	Duplex printing and Alternative Letterhead Mode
Letterhead, preprinted, or prepunched	Face-up Top edge leading into the printer	Face-down Bottom edge leading into the printer
		

Use alternative letterhead mode

Use the [Alternative Letterhead Mode](#) feature to load letterhead or preprinted paper into the tray the same way for all jobs, whether printing to one side of the sheet of paper or to both sides. When using this mode, load paper as for automatic duplex printing.

- [Enable Alternative Letterhead Mode by using the printer control-panel menus](#)

Enable Alternative Letterhead Mode by using the printer control-panel menus

Use the [Settings](#) menu to set the [Alternative Letterhead Mode](#) setting

1. From the Home screen on the printer control panel, open the [Settings](#) menu.
2. Open the following menus:
 - [Copy/Print or Print](#)
 - [Manage Trays](#)
 - [Alternative Letterhead Mode](#)
3. Select [Enabled](#), and then touch the [Save](#) button or press the [OK](#) button.

Load paper to Tray 2 and the 550-sheet trays

The following information describes how to load paper into Tray 2 and the optional 550-sheet trays.

- [Load paper to Tray 2 and the 550-sheet trays](#)
- [Tray 2 and the 550-sheet trays paper orientation](#)
- [Use alternative letterhead mode](#)

 **NOTE:** The procedure to load paper for the 550-sheet trays is the same as for Tray 2. Only Tray 2 is shown here.

 **CAUTION:** Do not extend more than one paper tray at a time.

Load paper to Tray 2 and the 550-sheet trays

The following information describes how to load paper in Tray 2 and the optional 550-sheet trays. These trays hold up to 550 sheets of 75 g/m² (20 lb) paper.

 **NOTE:** The procedure to load paper for the 550-sheet trays is the same as for Tray 2. Only Tray 2 is shown here.

 **NOTE:** Do not extend more than one paper tray at a time.

1. Open the tray.

NOTE: Do not open this tray while it is in use.

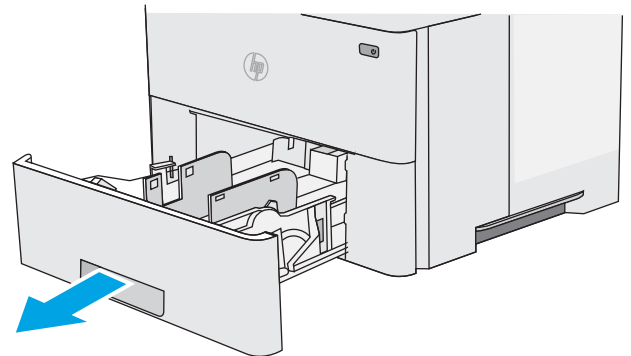

2. Before loading paper, adjust the paper-width guides by squeezing the adjustment latches and sliding the guides to the size of the paper being used.

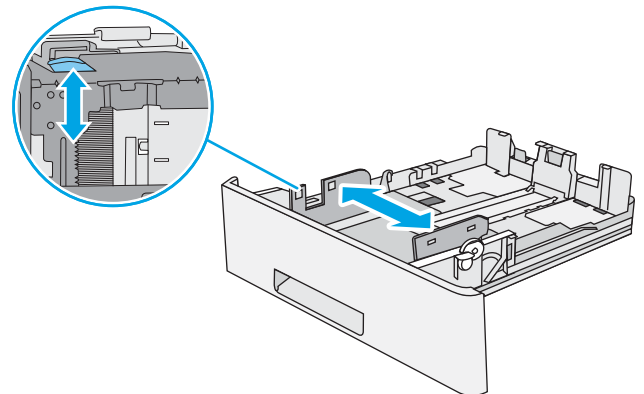

3. Adjust the paper-length guide by squeezing the adjustment latch and sliding the guide to the size of the paper being used.

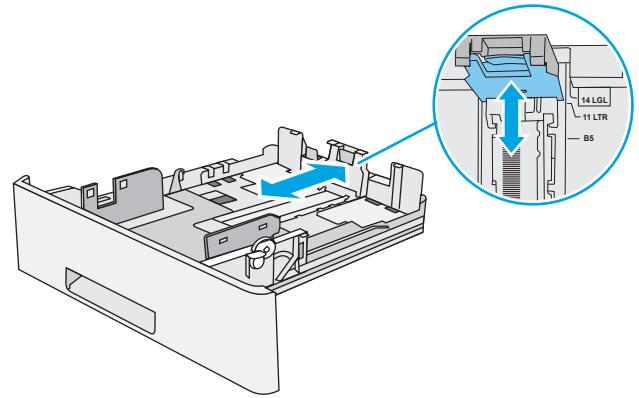

4. To load legal-size paper into the tray, squeeze the lever on the back of the tray that is to the left of center, and then extend the tray back to the correct paper size.

NOTE: This step does not apply to other paper sizes.

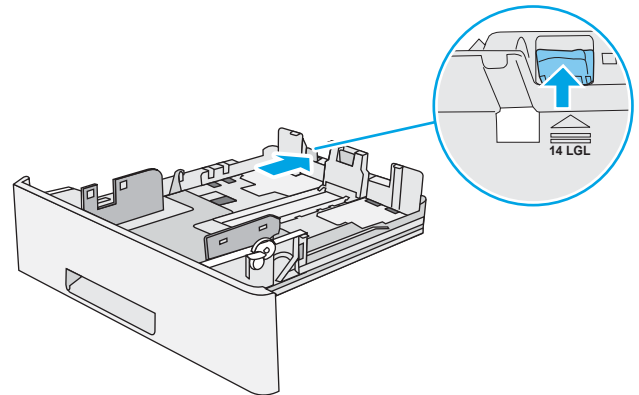

5. Load paper into the tray. For information about how to orient the paper, see [Tray 2 and the 550-sheet trays paper orientation on page 21](#).

NOTE: Do not adjust the paper guides tightly against the paper stack. Adjust them to the indentations or markings in the tray.

NOTE: To prevent jams, adjust the paper guides to the correct size and do not overfill the tray. Be sure that the top of the stack is below the tray full indicator, as shown in the enlargement in the illustration.

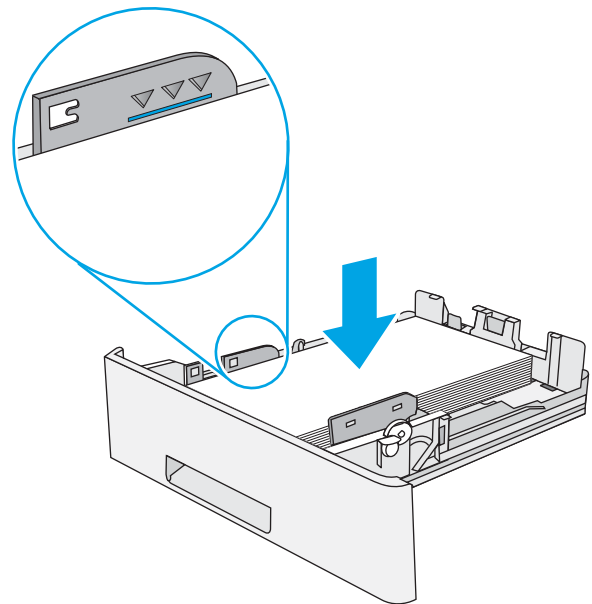

6. Close the tray.

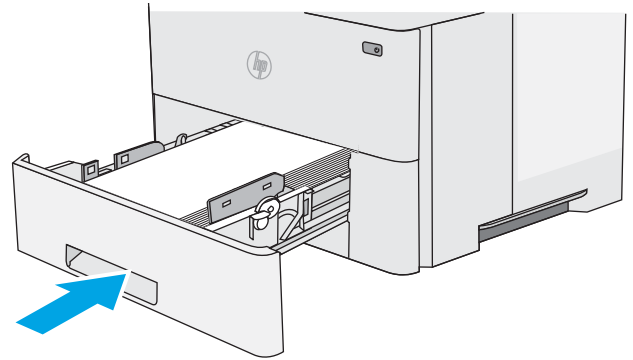

7. The tray configuration message displays on the printer control panel.
8. If the paper size and type shown is not correct, select **Modify** to choose a different paper size or type.

For custom-size paper, specify the X and Y dimensions for the paper when the prompt displays on the printer control panel.

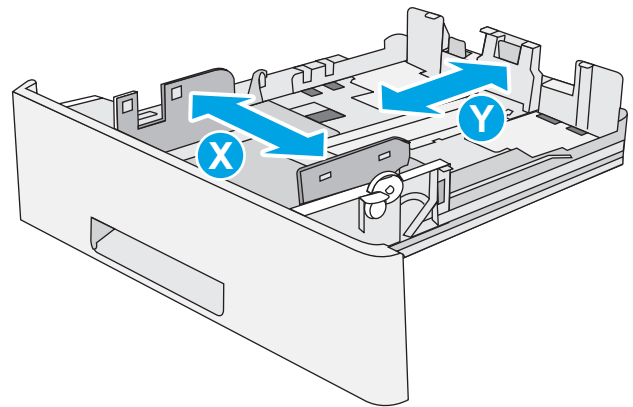

Tray 2 and the 550-sheet trays paper orientation

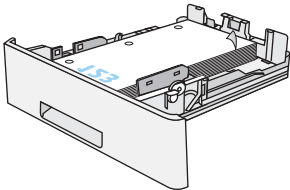
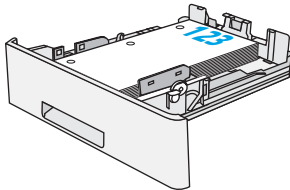
Paper type	Single-sided printing	Duplex printing and Alternative Letterhead Mode
Letterhead, preprinted, or prepunched	Face-down Top edge at the front of the tray	Face-up Bottom edge at the front of the tray
		

Use alternative letterhead mode

Use the [Alternative Letterhead Mode](#) feature to load letterhead or preprinted paper into the tray the same way for all jobs, whether printing to one side of the sheet of paper or to both sides. When using this mode, load paper as for automatic duplex printing.

- [Enable Alternative Letterhead Mode by using the printer control-panel menus](#)

Enable Alternative Letterhead Mode by using the printer control-panel menus

Use the [Settings](#) menu to set the [Alternative Letterhead Mode](#) setting

1. From the Home screen on the printer control panel, open the [Settings](#) menu.
2. Open the following menus:
 - [Copy/Print or Print](#)
 - [Manage Trays](#)
 - [Alternative Letterhead Mode](#)
3. Select [Enabled](#), and then touch the [Save](#) button or press the [OK](#) button.

Load and print envelopes

Use only tray 1 to print on envelopes. Tray 1 holds up to 10 envelopes.

- [Print envelopes](#)
- [Envelope orientation](#)

Print envelopes

To print envelopes using the manual feed option, follow these steps to select the correct settings in the print driver, and then load the envelopes into the tray after sending the print job to the printer.

1. From the software program, select the **Print** option.
2. Select the printer from the list of printers, and then click the **Properties** or **Preferences** button to open the print driver.

 **NOTE:** The name of the button varies for different software programs.

 **NOTE:** To access these features from a Windows 8 or 8.1 Start screen, select **Devices**, select **Print**, and then select the printer.

3. Click the **Paper/Quality** tab.
4. In the **Paper size** drop-down list, select the correct size for the envelopes.
5. In the **Paper type** drop-down list, select **Envelope**.
6. In the **Paper source** drop-down list, select **Manual feed**.
7. Click the **OK** button to close the **Document Properties** dialog box.
8. In the **Print** dialog box, click the **OK** button to print the job.

Envelope orientation

Load envelopes in Tray 1 face up, with the short, postage end leading into the printer.

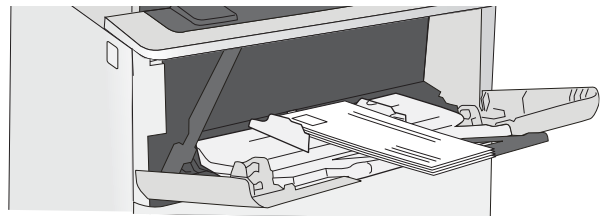

Load and print labels

To print on sheets of labels, use tray 1. Tray 2 and the optional 550-sheet trays do not support labels.

- [Manually feed labels](#)
- [Label orientation](#)

Manually feed labels

Use the manual feed mode for Tray 1 to print sheets of labels.

1. From the software program, select the **Print** option.
2. Select the printer from the list of printers, and then click the **Properties** or **Preferences** button to open the print driver.

 **NOTE:** The name of the button varies for different software programs.

 **NOTE:** To access these features from a Windows 8 or 8.1 Start screen, select **Devices**, select **Print**, and then select the printer.

3. Click the **Paper/Quality** tab.
4. In the **Paper size** drop-down list, select the correct size for the sheets of labels.
5. In the **Paper type** drop-down list, select **Labels**.
6. In the **Paper source** drop-down list, select **Manual feed**.
7. Click the **OK** button to close the **Document Properties** dialog box.
8. In the **Print** dialog box, click the **Print** button to print the job.

Label orientation

Labels need to be loaded in a specific manner in order to print correctly.

Tray	How to load labels
Tray 1	Load sheets of labels face-up with the top of the sheet leading into the printer.

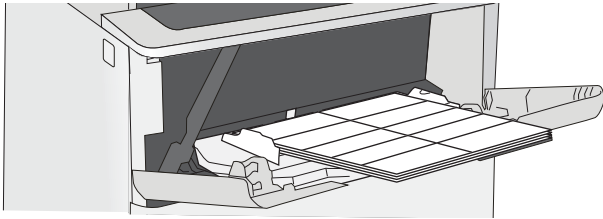

3 Supplies, accessories, and parts

Order supplies or accessories, replace the toner cartridges, or remove and replace another part.

- [Order supplies, accessories, and parts](#)
- [Replace the toner cartridge](#)

For video assistance, see www.hp.com/videos/LaserJet.

The following information is correct at the time of publication. For current information, see <http://www.hp.com/support/ljE50145>.

For more information:

HP's all-inclusive help for the printer includes the following information:

- Install and configure
- Learn and use
- Solve problems
- Download software and firmware updates
- Join support forums
- Find warranty and regulatory information

Order supplies, accessories, and parts

Review details about ordering supplies, accessories and parts for your printer.

- [Ordering](#)
- [Supplies and accessories](#)
- [Customer self-repair parts](#)

Ordering

Order supplies and paper	www.hp.com/go/suresupply
Order genuine HP parts or accessories	www.hp.com/buy/parts
Order through service or support providers	Contact an HP-authorized service or support provider.
Order using the HP Embedded Web Server (EWS)	To access, in a supported web browser on your computer, enter the printer IP address or host name in the address/URL field. The EWS contains a link to the HP SureSupply website, which provides options for purchasing Original HP supplies.

Supplies and accessories

Item	Description	Part number
Accessories		
HP LaserJet 550-sheet Paper Tray	Optional 550-sheet paper feeder NOTE: The printer supports up to three 1 x 550-sheet paper feeders unless other input devices are present.	F2A72A
HP LaserJet Printer Stand	Optional printer stand	F2A73A
1 GB DDR3 SlimDIMM	Optional DIMM for expanding the memory	G6W84A
HP Trusted Platform Module	Automatically encrypts all data that passes through the printer	F5S62A
HP Secure High Performance Hard Disk Drive	Optional secure HDD	B5L29A
HP Jetdirect 2900nw Print Server	USB wireless print server accessory	J8031A
HP JetDirect 3100w BLE/NFC/Wireless Accessory	Wi-Fi direct accessory for “touch” printing from mobile devices	3JN69A
HP Internal USB ports	Two internal USB ports for connecting third-party devices	B5L28A

Customer self-repair parts

Customer Self-Repair (CSR) parts are available for many HP LaserJet printers to reduce repair time. More information about the CSR program and benefits can be found at www.hp.com/go/csr-support and www.hp.com/go/csr-faq.

Genuine HP replacement parts can be ordered at www.hp.com/buy/parts or by contacting an HP-authorized service or support provider. When ordering, one of the following will be needed: part number, serial number (found on back of printer), product number, or printer name.

- Parts listed as **Mandatory** self-replacement are to be installed by customers, unless you are willing to pay HP service personnel to perform the repair. For these parts, on-site or return-to-depot support is not provided under the HP printer warranty.
- Parts listed as **Optional** self-replacement can be installed by HP service personnel at your request for no additional charge during the printer warranty period.

Item	Description	Self-replacement options	Part number
1 x 550 Sheet Feeder Kit	Replacement 1 x 550-sheet feeder	Mandatory	F2A72A
Secure Hard Disk Drive	Replacement hard disk drive	Mandatory	B5L29A
1 GB DDR3 SlimDIMM	Replacement memory DIMM	Mandatory	G6W84A
HP Trusted Platform Module kit	Replacement trusted platform module	Mandatory	F5S62A
HP Jetdirect 2900nw Print Server	Replacement USB wireless print server accessory	Mandatory	J8031A
HP JetDirect 3100w BLE/NFC/Wireless Accessory	Replacement Wireless Direct Print accessory for "touch" printing from mobile devices	Mandatory	3JN69A
HP Internal USB Ports	Replacement internal USB ports	Mandatory	B5L28A

Replace the toner cartridge

Replace the toner cartridge if you receive a message on the printer, or if you have print quality problems.

- [Cartridge information](#)
- [Remove and replace the cartridge](#)

Cartridge information

This printer indicates when the toner cartridge level is low and very low. The actual toner cartridge life remaining can vary. Consider having a replacement cartridge available to install when print quality is no longer acceptable.

To purchase cartridges, contact your managed service representative. Make sure that you know your product model number, which appears on the product label on the back of the printer. To check cartridge compatibility for the printer, go to HP SureSupply at www.hp.com/go/SureSupply. Scroll to the bottom of the page and verify that the country/region is correct.

 **NOTE:** High-yield toner cartridges contain more toner than standard cartridges for increased page yield. For more information, go to www.hp.com/go/learnaboutsupplies.

Do not remove the toner cartridge from its package until it is time to replace it.

 **CAUTION:** To prevent damage to the toner cartridge, do not expose it to light for more than a few minutes. Cover the green imaging drum if the toner cartridge must be removed from the printer for an extended period of time.

The following illustration shows the toner-cartridge components.

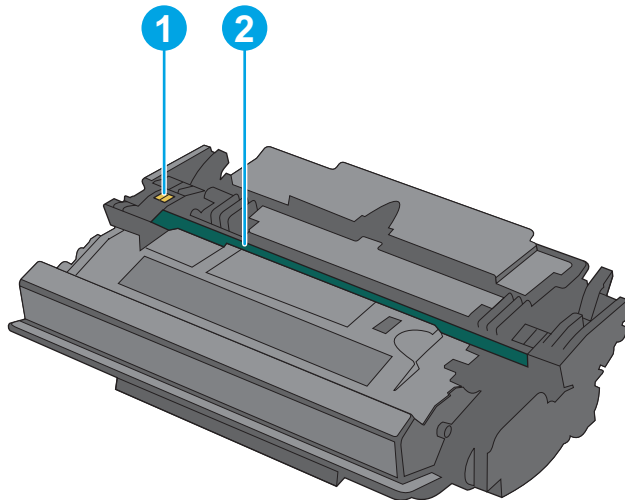

-
- | | |
|---|--------------|
| 1 | Memory chip |
| 2 | Imaging drum |
-

CAUTION: Do not touch the imaging drum. Fingerprints can cause print-quality problems.

 **CAUTION:** If toner gets on clothing, wipe it off by using a dry cloth and wash the clothes in cold water. Hot water sets toner into fabric.

 **NOTE:** Information about recycling used toner cartridges is in the toner-cartridge box.

Remove and replace the cartridge

1. Press the top-cover-release button on the left side of the printer.

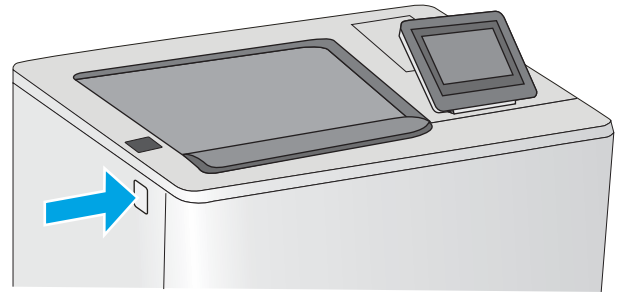

2. Open the front door.

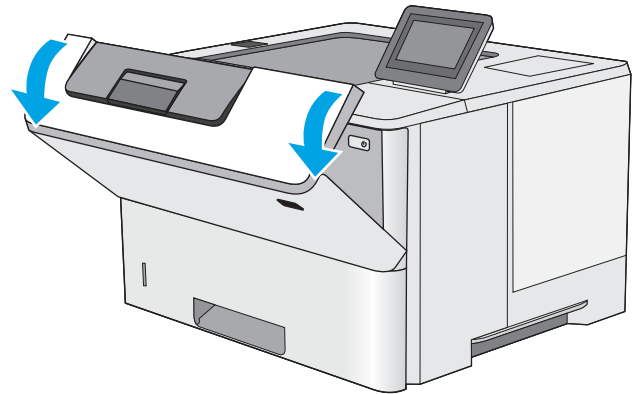

3. Grasp the handle of the used toner cartridge and pull out to remove it.

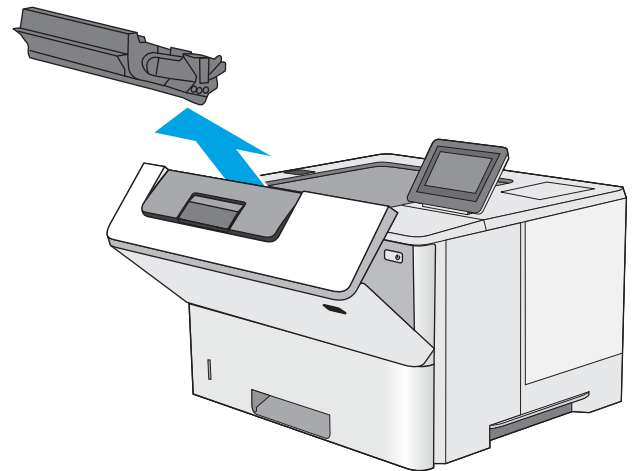

4. Remove the new toner cartridge from its protective shell by tearing off the plastic strip and opening the package. Save all packaging for recycling the used toner cartridge.

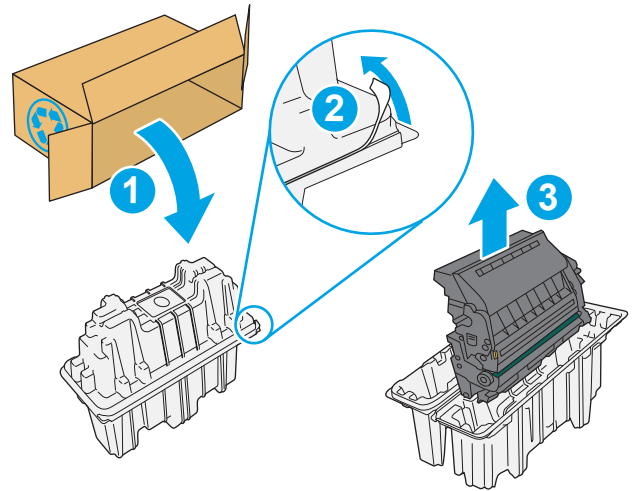

5. Align the toner cartridge with its slot, and then insert the toner cartridge into the printer.

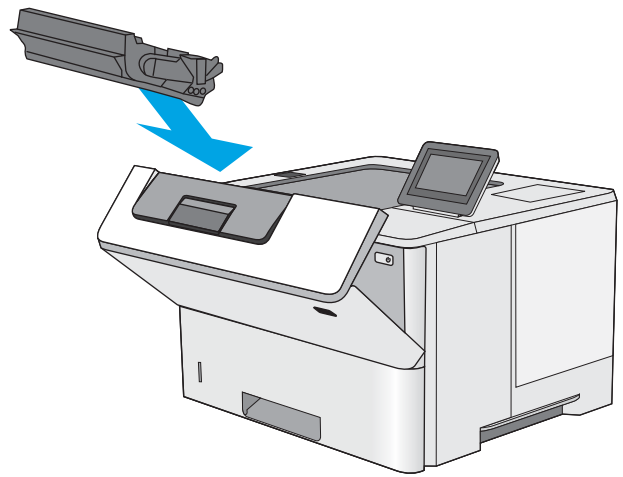

6. Close the front door.

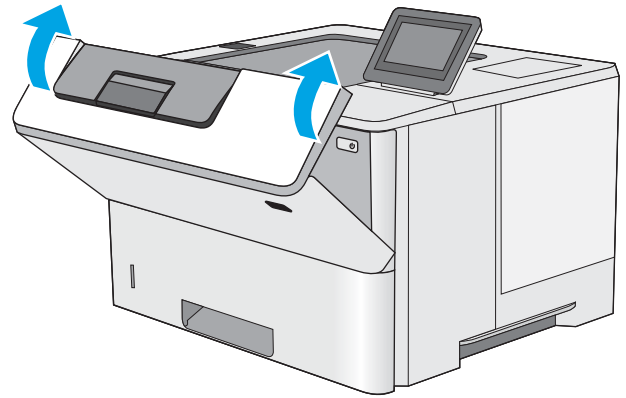

7. Pack the used toner cartridge into the box that the new cartridge came in. See the enclosed recycling guide for information about recycling.

In the U.S. and Canada, a pre-paid shipping label is included in the box. In other countries/regions, go to www.hp.com/recycle to print a pre-paid shipping label.

Adhere the pre-paid shipping label to the box, and return the used cartridge to HP for recycling.

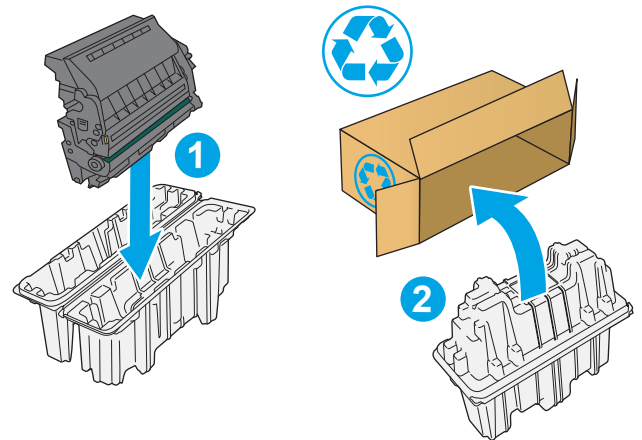

4 Print

Print using the software, or print from a mobile device or USB flash drive.

- [Print tasks \(Windows\)](#)
- [Print tasks \(macOS\)](#)
- [Store print jobs on the printer to print later or print privately](#)
- [Print from a USB flash drive](#)
- [Print using high-speed USB 2.0 port \(wired\)](#)

For video assistance, see www.hp.com/videos/LaserJet.

The following information is correct at the time of publication. For current information, see <http://www.hp.com/support/ljE50145>.

For more information:

HP's all-inclusive help for the printer includes the following information:

- Install and configure
- Learn and use
- Solve problems
- Download software and firmware updates
- Join support forums
- Find warranty and regulatory information

Print tasks (Windows)

Learn about common printing tasks for Windows users.

- [How to print \(Windows\)](#)
- [Automatically print on both sides \(Windows\)](#)
- [Manually print on both sides \(Windows\)](#)
- [Print multiple pages per sheet \(Windows\)](#)
- [Select the paper type \(Windows\)](#)
- [Additional print tasks](#)

How to print (Windows)

Use the **Print** option from a software application to select the printer and basic options for your print job.

The following procedure describes the basic printing process for Windows.

1. From the software program, select the **Print** option.
2. Select the printer from the list of printers. To change settings, click the **Properties** or **Preferences** button to open the print driver.



NOTE: The name of the button varies for different software programs.

In Windows 10, 8.1, and 8, these applications will have a different layout with different features from what is described below for desktop applications. To access the print feature from a Start screen app, complete the following steps:

- **Windows 10:** Select **Print**, and then select the printer.
- **Windows 8.1 or 8:** Select **Devices**, select **Print**, and then select the printer.

For the HP PCL-6 V4 driver, the HP AiO Printer Remote application downloads additional driver features when **More settings** is selected.



NOTE: For more information, click the Help (?) button in the print driver.

3. Click the tabs in the print driver to configure the available options. For example, set the paper orientation on the **Finishing** tab, and set the paper source, paper type, paper size, and quality settings on the **Paper/Quality** tab.
4. Click the **OK** button to return to the **Print** dialog box. Select the number of copies to print from this screen.
5. Click the **Print** button to print the job.

Automatically print on both sides (Windows)

If your printer has an automatic duplexer installed, you can automatically print on both sides of the paper. Use a paper size and type supported by the duplexer.

1. From the software program, select the **Print** option.
2. Select the printer from the list of printers, and then click the **Properties** or **Preferences** button to open the print driver.

 **NOTE:** The name of the button varies for different software programs.

In Windows 10, 8.1, and 8, these applications will have a different layout with different features from what is described below for desktop applications. To access the print feature from a Start screen app, complete the following steps:

- **Windows 10:** Select **Print**, and then select the printer.
- **Windows 8.1 or 8:** Select **Devices**, select **Print**, and then select the printer.

For the HP PCL-6 V4 driver, the HP AiO Printer Remote application downloads additional driver features when **More settings** is selected.

3. Click the **Finishing** tab.
4. Select **Print on both sides**. Click **OK** to close the **Document Properties** dialog.
5. In the **Print** dialog, click **Print** to print the job.

Manually print on both sides (Windows)

Use this procedure for printers that do not have an automatic duplexer installed or to print on paper that the duplexer does not support.

1. From the software program, select the **Print** option.
2. Select the printer from the list of printers, and then click the **Properties** or **Preferences** button to open the print driver.

 **NOTE:** The name of the button varies for different software programs.

In Windows 10, 8.1, and 8, these applications will have a different layout with different features from what is described below for desktop applications. To access the print feature from a Start screen app, complete the following steps:

- **Windows 10:** Select **Print**, and then select the printer.
- **Windows 8.1 or 8:** Select **Devices**, select **Print**, and then select the printer.

For the HP PCL-6 V4 driver, the HP AiO Printer Remote application downloads additional driver features when **More settings** is selected.

3. Click the **Finishing** tab.
4. Select **Print on both sides (manually)**, and then click **OK** to close the **Document Properties** dialog.
5. In the **Print** dialog, click **Print** to print the first side of the job.
6. Retrieve the printed stack from the output bin, and place it in Tray 1.
7. If prompted, select the appropriate control panel button to continue.

Print multiple pages per sheet (Windows)

When you print from a software application using the **Print** option, you can select an option to print multiple pages on a single sheet of paper. For example, you might want to do this if you are printing a very large document and want to save paper.

1. From the software program, select the **Print** option.
2. Select the printer from the list of printers, and then click the **Properties** or **Preferences** button to open the print driver.

 **NOTE:** The name of the button varies for different software programs.

In Windows 10, 8.1, and 8, these applications will have a different layout with different features from what is described below for desktop applications. To access the print feature from a Start screen app, complete the following steps:

- **Windows 10:** Select **Print**, and then select the printer.
- **Windows 8.1 or 8:** Select **Devices**, select **Print**, and then select the printer.

For the HP PCL-6 V4 driver, the HP AiO Printer Remote application downloads additional driver features when **More settings** is selected.

3. Click the **Finishing** tab.
4. Select the number of pages per sheet from the **Pages per sheet** drop-down.
5. Select the correct **Print page borders**, **Page order**, and **Orientation** options. Click **OK** to close the **Document Properties** dialog.
6. In the **Print** dialog, click **Print** to print the job.

Select the paper type (Windows)

When you print from a software application using the **Print** option, you can set the paper type you are using for your print job. For example, if your default paper type is Letter, but you are using a different paper type for a print job, select that specific paper type.

1. From the software program, select the **Print** option.
2. Select the printer from the list of printers, and then click the **Properties** or **Preferences** button to open the print driver.

 **NOTE:** The name of the button varies for different software programs.

In Windows 10, 8.1, and 8, these applications will have a different layout with different features from what is described below for desktop applications. To access the print feature from a Start screen app, complete the following steps:

- **Windows 10:** Select **Print**, and then select the printer.
- **Windows 8.1 or 8:** Select **Devices**, select **Print**, and then select the printer.

For the HP PCL-6 V4 driver, the HP AiO Printer Remote application downloads additional driver features when **More settings** is selected.

3. Click the **Paper/Quality** tab.
4. Select the paper type from the **Paper type** drop-down list.
5. Click **OK** to close the **Document Properties** dialog. In the **Print** dialog, click **Print** to print the job.

If the tray needs to be configured, a tray configuration message displays on the printer control panel.

6. Load the tray with the specified type and size of paper, and then close the tray.
7. Touch the **OK** button to accept the detected type and size, or touch the **Modify** button to choose a different paper size or type.
8. Select the correct type and size, and then touch the **OK** button.

Additional print tasks

Locate information on the Web for performing common printing tasks.

Go to <http://www.hp.com/support/ljE50145>.

Instructions are available for print tasks, such as the following:

- Create and use printing shortcuts or presets
- Select the paper size, or use a custom paper size
- Select the page orientation
- Create a booklet
- Scale a document to fit a specific paper size
- Print the first or last pages of the document on different paper
- Print watermarks on a document

Print tasks (macOS)

Print using the HP printing software for macOS, including how to print on both sides or print multiple pages per sheet.

- [How to print \(macOS\)](#)
- [Automatically print on both sides \(macOS\)](#)
- [Manually print on both sides \(macOS\)](#)
- [Print multiple pages per sheet \(macOS\)](#)
- [Select the paper type \(macOS\)](#)
- [Additional print tasks](#)

How to print (macOS)

The following procedure describes the basic printing process for macOS.

1. Click the **File** menu, and then click the **Print** option.
2. Select the printer.
3. Click **Show Details** or **Copies & Pages**, and then select other menus to adjust the print settings.

 **NOTE:** The name of the item varies for different software programs.

4. Click the **Print** button.

Automatically print on both sides (macOS)

 **NOTE:** This information applies to printers that include an automatic duplexer.

 **NOTE:** This feature is available if you install the HP print driver. It might not be available if you are using AirPrint.

1. Click the **File** menu, and then click the **Print** option.
2. Select the printer.
3. Click **Show Details** or **Copies & Pages**, and then click the **Layout** menu.

 **NOTE:** The name of the item varies for different software programs.

4. Select a binding option from the **Two-Sided** drop-down list.
5. Click the **Print** button.

Manually print on both sides (macOS)

 **NOTE:** This feature is available if you install the HP print driver. It might not be available if you are using AirPrint.

1. Click the **File** menu, and then click the **Print** option.
2. Select the printer.
3. Click **Show Details** or **Copies & Pages**, and then click the **Manual Duplex** menu.

 **NOTE:** The name of the item varies for different software programs.

4. Click the **Manual Duplex** box, and select a binding option.
5. Click the **Print** button.
6. Go to the printer, and remove any blank paper that is in Tray 1.
7. Retrieve the printed stack from the output bin and place it with the printed-side facing down in the input tray.
8. If prompted, touch the appropriate control panel button to continue.

Print multiple pages per sheet (macOS)

1. Click the **File** menu, and then click the **Print** option.
2. Select the printer.
3. Click **Show Details** or **Copies & Pages**, and then click the **Layout** menu.

 **NOTE:** The name of the item varies for different software programs.

4. From the **Pages per Sheet** drop-down list, select the number of pages that you want to print on each sheet.
5. In the **Layout Direction** area, select the order and placement of the pages on the sheet.
6. From the **Borders** menu, select the type of border to print around each page on the sheet.
7. Click the **Print** button.

Select the paper type (macOS)

1. Click the **File** menu, and then click the **Print** option.
2. Select the printer.
3. Click **Show Details** or **Copies & Pages**, and then click the **Media & Quality** menu or the **Paper/Quality** menu.

 **NOTE:** The name of the item varies for different software programs.

4. Select from the **Media & Quality** or **Paper/Quality** options.

 **NOTE:** This list contains the master set of options available. Some options are not available on all printers.

- **Media Type:** Select the option for the type of paper for the print job.
 - **Print Quality:** Select the resolution level for the print job.
 - **Edge-To-Edge Printing:** Select this option to print close to the paper edges.
5. Click the **Print** button.

Additional print tasks

Locate information on the Web for performing common printing tasks.

Go to <http://www.hp.com/support/ljE50145>.

Instructions are available for print tasks, such as the following:

- Create and use printing shortcuts or presets
- Select the paper size, or use a custom paper size
- Select the page orientation
- Create a booklet
- Scale a document to fit a specific paper size
- Print the first or last pages of the document on different paper
- Print watermarks on a document

Store print jobs on the printer to print later or print privately

- [Introduction](#)
- [Create a stored job \(Windows\)](#)
- [Create a stored job \(macOS\)](#)
- [Print a stored job](#)
- [Delete a stored job](#)
- [Information sent to printer for Job Accounting purposes](#)

Introduction

The following information provides procedures for creating and printing documents that are stored on the USB flash drive. These jobs can be printed at a later time or printed privately.

Create a stored job (Windows)

Store jobs on the USB flash drive for private or delayed printing.

1. From the software program, select the **Print** option.
2. Select the printer from the list of printers, and then select **Properties** or **Preferences**.



NOTE: The name of the button varies for different software programs.

In Windows 10, 8.1, and 8, these applications will have a different layout with different features from what is described below for desktop applications. To access the print feature from a Start screen app, complete the following steps:

- **Windows 10:** Select **Print**, and then select the printer.
- **Windows 8.1 or 8:** Select **Devices**, select **Print**, and then select the printer.

For the HP PCL-6 V4 driver, the HP AiO Printer Remote application downloads additional driver features when **More settings** is selected.

3. Click the **Job Storage** tab.
4. Select a **Job Storage Mode** option:
 - **Proof and Hold:** Print and proof one copy of a job, and then print more copies.
 - **Personal Job:** The job does not print until you request it at the printer control panel. For this job-storage mode, you can select one of the **Make Job Private/Secure** options. If you assign a personal identification number (PIN) to the job, you must provide the required PIN at the control panel. If you encrypt the job, you must provide the required password at the control panel. The print job is deleted from memory after it prints and is lost if the printer loses power.
 - **Quick Copy:** Print the requested number of copies of a job and store a copy of the job in the printer memory so you can print it again later.
 - **Stored Job:** Store a job on the printer and allow other users to print the job at any time. For this job-storage mode, you can select one of the **Make Job Private/Secure** options. If you assign a personal identification number (PIN) to the job, the person who prints the job must provide the required PIN at

the control panel. If you encrypt the job, the person who prints the job must provide the required password at the control panel.

5. To use a custom user name or job name, click the **Custom** button, and then enter the user name or the job name.

Select which option to use if another stored job already has that name:

- **Use Job Name + (1-99):** Append a unique number to the end of the job name.
 - **Replace Existing File:** Overwrite the existing stored job with the new one.
6. Click the **OK** button to close the **Document Properties** dialog box. In the **Print** dialog box, click the **Print** button to print the job.

Create a stored job (macOS)

Store jobs on the USB flash drive for private or delayed printing.

1. Click the **File** menu, and then click the **Print** option.
2. In the **Printer** menu, select the printer.
3. By default, the print driver displays the **Copies & Pages** menu. Open the drop-down list, and then click the **Job Storage** menu.



NOTE: If the **Job Storage** menu is not showing, close the Print window and then reopen it to activate the menu.

4. In the **Mode** drop-down list, select the type of stored job.
 - **Proof and Hold:** Print and proof one copy of a job, and then print more copies.
 - **Personal Job:** The job does not print until someone requests it at the printer control panel. If the job has a personal identification number (PIN), provide the required PIN at the control panel. The print job is deleted from memory after it prints and is lost if the printer loses power.
 - **Quick Copy:** Print the requested number of copies of a job and store a copy of the job in the printer memory to print it again later.
 - **Stored Job:** Store a job on the printer and allow other users to print the job at any time. If the job has a personal identification number (PIN), the person who prints the job must provide the required PIN at the control panel.

5. To use a custom user name or job name, click the **Custom** button, and then enter the user name or the job name.

Select which option to use if another stored job already has that name.

- **Use Job Name + (1-99):** Append a unique number to the end of the job name.
 - **Replace Existing File:** Overwrite the existing stored job with the new one.
6. If you selected the **Stored Job** or **Personal Job** option in step 4, you can protect the job with a PIN. Type a 4-digit number in the **Use PIN to Print** field. When other people attempt to print this job, the printer prompts them to enter this PIN number.
 7. Click the **Print** button to process the job.

Print a stored job

Use the following procedure to print a job that is stored in the printer memory.

1. From the Home screen on the printer control panel, navigate to the **Print** application, and then select the **Print** icon.
2. Select **Print from Job Storage**.
3. Select **Choose**, and then select the name of the folder where the job is stored.
4. Select the name of the job. If the job is private or encrypted, enter the PIN or password.
5. To adjust the number of copies, select the number of copies field in the bottom-left corner of the screen. Use the keypad to enter the number of copies to print.
6. Select **Start**  or **Print** to print the job.

Delete a stored job

You can delete documents that have been saved to the printer when they are no longer needed. You also can adjust the maximum number of jobs for the printer to store.

- [Delete a job that is stored on the printer](#)
- [Change the job storage limit](#)

Delete a job that is stored on the printer

Use the control panel to delete a job that is stored in the printer memory.

1. From the Home screen on the printer control panel, navigate to the [Print](#) application, and then select the [Print](#) icon.
2. Select [Print from Job Storage](#).
3. Select [Choose](#), and then select the name of the folder where the job is stored.
4. Select the name of the job. If the job is private or encrypted, enter the PIN or password.
5. Select the Trash  button to delete the job.

Change the job storage limit

When a new job is stored in the printer memory, the printer overwrites any previous jobs with the same user and job name. If a job is not already stored under the same user and job name, and the printer needs additional space, the printer might delete other stored jobs starting with the oldest.

To change the number of jobs that the printer can store, complete the following procedure:

1. From the Home screen on the printer control panel, navigate to the [Settings](#) application, and then select the [Settings](#) icon.
2. Open the following menus:
 - [Copy/Print](#) or [Print](#)
 - [Manage Stored Jobs](#)
 - [Temporary Job Storage Limit](#)
3. Use the keypad to enter the number of jobs that the printer stores.
4. Select [OK](#) or [Done](#) to save the setting.

Information sent to printer for Job Accounting purposes

Printing jobs sent from drivers on the client (e.g., PC) may send personally identifiable information to HP's Printing and Imaging devices. This information may include, but is not limited to, user name and client name from which the job originated that may be used for job accounting purposes, as determined by the Administrator of the printing device. This same information may also be stored with the job on the mass storage device (e.g., disk drive) of the printing device when using the job storage feature.

Print from a USB flash drive

This printer features easy-access USB printing, for quickly printing files without sending them from a computer.

- [Enable the USB port for printing](#)
- [Print USB documents](#)

The printer accepts standard USB flash drives in the USB port near the control panel. It supports the following types of files:

- .pdf
- .prn
- .pcl
- .ps
- .cht

Enable the USB port for printing

The USB port is disabled by default. Before using this feature, enable the USB port.



- [Method one: Enable the USB port from the printer control panel](#)
- [Method two: Enable the USB port from the HP Embedded Web Server \(network-connected printers only\)](#)

Use one of the following methods to enable the port:

Method one: Enable the USB port from the printer control panel

1. From the Home screen on the printer control panel, navigate to the [Settings](#) application, and then select the [Settings](#) icon.
2. Open the following menus
 - [Copy/Print](#) or [Print](#)
 - [Enable Device USB](#)
3. Select [Enabled](#) to enable the USB port.

Method two: Enable the USB port from the HP Embedded Web Server (network-connected printers only)

1. From the Home screen on the printer control panel, select the Information  icon, and then select the Network  icon to display the IP address or host name
2. Open a web browser, and in the address line, type the IP address exactly as it displays on the printer control panel. Press the [Enter](#) key on the computer keyboard. The EWS opens.



NOTE: If the web browser displays a **There is a problem with this website's security certificate** message when attempting to open the EWS, click **Continue to this website (not recommended)**.

Choosing **Continue to this website (not recommended)** will not harm the computer while navigating within the EWS for the HP printer.

3. Select the **Copy/Print** tab for MFP models or the **Print** tab for SFP models.
4. In the left menu, select **Print from USB Drive Settings**.
5. Select **Enable Print from USB Drive**.
6. Click **Apply**.

Print USB documents

1. Insert the USB flash drive into the easy-access USB port.



NOTE: The port might be covered. For some printers, the cover flips open. For other printers, pull the cover straight out to remove it.

2. From the Home screen on the printer control panel, navigate to the [Print](#) application, and then select the [Print](#) icon.

3. Select [Print from USB Drive](#).
4. Select [Choose](#), select the name of the document to print, and then select [Select](#).



NOTE: The document might be in a folder. Open folders as necessary.

5. To adjust the number of copies, touch the box to the left of the [Print](#) button, and then select the number of copies from the keypad that opens. Select the Close  button to close the keypad.
6. Select [Print](#) to print the document.

Print using high-speed USB 2.0 port (wired)

- [Enable the high-speed USB port for printing](#)

Enable the high-speed USB port for printing

This printer features a high-speed USB 2.0 port for wired USB printing. The port is located in the interface ports area and is disabled by default. Use one of the following methods to enable the port. Once the port is enabled, install the product software in order to print using this port.

- [Method one: Enable the high-speed USB 2.0 port from the printer control panel menus](#)
- [Method two: Enable the high-speed USB 2.0 port from the HP Embedded Web Server \(network-connected printers only\)](#)



Method one: Enable the high-speed USB 2.0 port from the printer control panel menus

Use the control panel to enable the port.

1. From the Home screen on the printer control panel, navigate to the [Settings](#) application, and then select the [Settings](#) icon.
2. Open the following menus
 - [General](#)
 - [Enable Device USB](#)
3. Select the [Enabled](#) option.

Method two: Enable the high-speed USB 2.0 port from the HP Embedded Web Server (network-connected printers only)

Use the HP EWS to enable the port.

1. Find the printer IP address. On the printer control panel, select the Information  button, and then select the Network  icon to display the IP address or host name.
2. Open a web browser, and in the address line, type the IP address exactly as it displays on the printer control panel. Press the [Enter](#) key on the computer keyboard. The EWS opens.

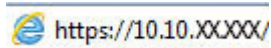

 **NOTE:** If the web browser displays a message indicating that accessing the website might not be safe, select the option to continue to the website. Accessing this website will not harm the computer.

3. Select the **Security** tab.
4. On the left side of the screen, select **General Security**.
5. Scroll down to the **Hardware Ports** and select the check box to enable both of the items:
 - **Enable Device USB**
 - **Enable Host USB plug and play**
6. Click **Apply**.

5 Manage the printer

Utilize management tools, security and energy-conservation settings, and firmware updates for the printer.

- [Advanced configuration with the HP Embedded Web Server \(EWS\)](#)
- [Configure IP network settings](#)
- [Printer security features](#)
- [Energy-conservation settings](#)
- [HP Web Jetadmin](#)
- [Software and firmware updates](#)

For video assistance, see www.hp.com/videos/LaserJet.

The following information is correct at the time of publication. For current information, see <http://www.hp.com/support/ljE50145>.

For more information:

HP's all-inclusive help for the printer includes the following information:

- Install and configure
- Learn and use
- Solve problems
- Download software and firmware updates
- Join support forums
- Find warranty and regulatory information

Advanced configuration with the HP Embedded Web Server (EWS)

- [Introduction](#)
- [How to access the HP Embedded Web Server \(EWS\)](#)
- [HP Embedded Web Server features](#)

Introduction

Use the HP Embedded Web Server to manage printing functions from a computer instead of the printer control panel.

- View printer status information
- Determine the remaining life for all supplies and order new ones
- View and change tray configurations
- View and change the printer control-panel menu configuration
- View and print internal pages
- Receive notification of printer and supplies events
- View and change network configuration



The HP Embedded Web Server works when the printer is connected to an IP-based network. The HP Embedded Web Server does not support IPX-based printer connections. Internet access is not needed to open and use the HP Embedded Web Server.

When the printer is connected to the network, the HP Embedded Web Server is automatically available.



NOTE: The HP Embedded Web Server is not accessible beyond the network firewall.

How to access the HP Embedded Web Server (EWS)

1. From the Home screen on the printer control panel, select the Information  icon, and then select the Network  icon to display the IP address or host name.
2. Open a web browser, and in the address line, type the IP address or host name exactly as it displays on the printer control panel. Press the **Enter** key on the computer keyboard. The EWS opens.



NOTE: If the web browser displays a message indicating that accessing the website might not be safe, select the option to continue to the website. Accessing this website will not harm the computer.

To use the HP Embedded Web Server, the browser must meet the following requirements:

Windows® 7

- Internet Explorer (version 8.x or greater)
- Google Chrome (version 34.x or greater)
- Firefox (version 20.x or greater)

Windows® 8 or greater

- Internet Explorer (version 9.x or greater)
- Google Chrome (version 34.x or greater)
- Firefox (version 20.x or greater)

macOS

- Safari (version 5.x or greater)
- Google Chrome (version 34.x or greater)

Linux

- Google Chrome (version 34.x or greater)
- Firefox (version 20.x or greater)

HP Embedded Web Server features

- [Information tab](#)
- [General tab](#)
- [Print tab](#)
- [Supplies tab](#)
- [Troubleshooting tab](#)
- [Security tab](#)
- [HP Web Services tab](#)
- [Networking tab](#)
- [Other Links list](#)

Information tab

Table 5-1 HP Embedded Web Server Information tab

Menu	Description
Device Status	Shows the printer status and shows the estimated life remaining of HP supplies. The page also shows the type and size of paper set for each tray. To change the default settings, click the Change Settings link.
Configuration Page	Shows the information found on the configuration page.
Supplies Status Page	Shows the status of the supplies for the printer.
Event Log Page	Shows a list of all printer events and errors. Use the HP Instant Support link (in the Other Links area on all HP Embedded Web Server pages) to connect to a set of dynamic web pages that help solve problems. These pages also show additional services available for the printer.
Usage Page	Shows a summary of the number of pages the printer has printed, grouped by size, type, and paper print path.
Device Information	Shows the printer network name, address, and model information. To customize these entries, click the Device Information menu on the General tab.
Control Panel Snapshot	Shows an image of the current screen on the control panel display.
Printable Reports and Pages	Lists the internal reports and pages for the printer. Select one or more items to print or view.
Open Source Licenses	Shows a summary of the licenses for open source software programs that can be used with the printer.

General tab

Table 5-2 HP Embedded Web Server General tab

Menu	Description
Control Panel Customization	Reorder, show, or hide features on the control-panel display. Change the default display language and keyboard layouts.
Quick Sets	Configure jobs that are available in the Quick Sets area of the Home screen on the printer control panel.
Alerts	Set up email alerts for various printer and supplies events.
Control Panel Settings App	Shows the Settings app options that are available on the printer control panel.
General Settings	Configure how the printer recovers from jams and other general printer settings.
AutoSend	Configure the printer to send automated emails regarding printer configuration and supplies to specific email addresses.
Edit Other Links	Add or customize a link to another website. This link displays in the footer area on all HP Embedded Web Server pages.
Ordering Information	Enter information about ordering replacement toner cartridges. This information displays on the supplies status page.
Device Information	Name the printer and assign an asset number to it. Enter the name of the primary contact who will receive information about the printer.
Language	Set the language in which to display the HP Embedded Web Server information.
Firmware Upgrade	Download and install printer firmware upgrade files.
Date/Time Settings	Set the date and time or synchronize with a network time server.
Energy Settings	Set or edit a wake time, sleep time, and sleep delay for the printer. Set a different schedule for each day of the week and for holidays. Set which interactions with the printer cause it to wake from sleep mode.
Back up and Restore	Create a backup file that contains printer and user data. If necessary, use this file to restore data to the printer.
Reset Factory Settings	Restore printer settings to the factory defaults.
Solution Installer	Install third-party software packages that extend or modify the functionality of the printer.
Job Statistics Settings	Provides connection information about third-party job-statistics services.
Quota Settings	Provides connection information about third-party job-quota services.

Print tab

Table 5-3 HP Embedded Web Server Print tab

Menu	Description
Print from USB Drive Settings	Enable or disable the Print from USB Drive menu on the control panel.
Manage Stored Jobs	Enable or disable the ability to store jobs in the printer memory. Configure job-storage options.
Default Print Options	Configure the default options for print jobs.

Table 5-3 HP Embedded Web Server Print tab (continued)

Menu	Description
Restrict Color (Color printers only)	Permit or restrict color printing. Specify permissions for individual users or for jobs that are sent from specific software programs.
PCL and PostScript Settings	Adjust the PCL and PostScript settings for all print jobs.
Print Quality	Configure the print quality settings, including color adjustment, image registration, and allowed paper types.
Manage Trays	Configure settings for paper trays.

Supplies tab

Table 5-4 HP Embedded Web Server Supplies tab

Menu	Description
Manage Supplies	Configure how the printer reacts when supplies reach a Very Low state.

Troubleshooting tab

Table 5-5 HP Embedded Web Server Troubleshooting tab

Menu	Description
General Troubleshooting	Select from a variety of reports and tests to help solve problems with the printer.
Online Help	Link to HP cloud-based online help to assist in troubleshooting printing issues.
Diagnostic Data	Export printer information to a file that can be useful for detailed problem analysis. NOTE: This item is available only if an administrator password is set from the Security tab.
Calibration/Cleaning (Color printers only)	Enable the automatic cleaning feature, create and print the cleaning page, and select an option to calibrate the printer immediately.
Restore Factory Settings	Restore printer settings to factory defaults.
Firmware Upgrade	Download and install printer firmware upgrade files.

Security tab

Table 5-6 HP Embedded Web Server Security tab

Menu	Description
General Security	Settings for general security, including the following: <ul style="list-style-type: none"> • Configure an administrator password to restrict access to certain features on the printer. • Set PJL password for processing PJL commands. • Set file system access and firmware upgrade security. • Enable or disable the Host USB port on the control panel or the USB connectivity port on the formatter for printing directly from a computer. • View the status of all security settings.
Account Policy	Enable administrator account settings.
Access Control	Configure access to printer functions for specific individuals or groups, and select the method individuals use to sign in to the printer.
Protect Stored Data	Configure and manage the internal hard drive for the printer. Configure settings for jobs that are stored on the printer hard drive.
Manage Remote Apps	Manage or whitelist remote apps by importing or deleting certificates that allow devices to use this product.
Certificate Management	Install and manage security certificates for access to the printer and the network.
Web Service Security	Allow resources on this printer to be accessed by web pages from different domains. If no sites are added to the list, then all sites are trusted.
Self Test	Verify that the security functions are running according to expected system parameters.

HP Web Services tab

Use the **HP Web Services** tab to configure and enable HP Web Services for this printer. It is necessary to Enable HP Web Services to use the HP ePrint feature.

Table 5-7 HP Embedded Web Server HP Web Services tab

Menu	Description
Web Services Setup	Connect this printer to HP Connected on the web by enabling HP Web Services.
Web Proxy	Configure a proxy server if there are issues enabling HP Web Services or connecting the printer to the Internet.
HP JetAdvantage	Access solutions that extend the capabilities of the printer
Smart Cloud Print	Enable Smart Cloud Print, which allows access to web-based apps that extend the capabilities of the printer.

Networking tab

Use the **Networking** tab to configure and secure network settings for the printer when it is connected to an IP-based network. This tab does not display if the printer is connected to other types of networks.

Table 5-8 HP Embedded Web Server Networking tab

Menu	Description
Configuration	
Wireless Station	Configure the initial wireless settings
Wi-Fi Direct	Configure Wi-Fi Direct settings for printers that include embedded Wi-Fi Direct Print and NFC printing or that have a wireless accessory installed. NOTE: The configuration options available depend on the print server model.
TCP/IP Settings	Configure TCP/IP settings for IPv4 and IPv6 networks. NOTE: The configuration options available depend on the print server model.
Network Settings	Configure IPX/SPX, AppleTalk, DLC/LLC, and SNMP settings, depending on the print server model.
Other Settings	Configure general printing protocols and services supported by the print server. The available options depend on the print server model, but can include firmware update, LPD queues, USB settings, support information, and refresh rate.
AirPrint	Enable, set up, or disable network printing from Apple supported printers.
Select Language	Change the language displayed by the HP Embedded Web Server. This page displays if the web pages support multiple languages. Optionally, select supported languages through language-preference settings in the browser.
Select Location	Select a country/region for the printer.
Google Cloud Print	
Setup	Set up Google Cloud Print options.
Web Proxy	Configure proxy settings.
Security	
Settings	View and restore current security settings to factory-default values. Configure security settings using the Security Configuration Wizard. NOTE: Do not use the Security Configuration Wizard to configure security settings using network-management applications, such as HP Web Jetadmin.
Authorization	Control configuration management and use of this printer, including the following: <ul style="list-style-type: none"> • Set or change the administrator password to control access to configuration parameters. • Request, install, and manage digital certificates on the HP Jetdirect print server. • Limit host access to this printer through an Access Control List (ACL) (for selected print servers on IPv4 networks only).
Secure Communication	Configure security settings.

Table 5-8 HP Embedded Web Server Networking tab (continued)

Menu	Description
Mgmt. Protocols	<p>Configure and manage security protocols for this printer, including the following:</p> <ul style="list-style-type: none"> Set the security management level for the HP Embedded Web Server, and control traffic over HTTP and HTTPS. Configure the SNMP (Simple Network Management Protocol) operation. Enable or disable the SNMP v1/v2c or SNMP v3 agents on the print server. Control access through protocols that may not be secure, such as printing protocols, print services, discovery protocols, name resolution services, and configuration-management protocols.
802.1X Authentication	<p>Configure 802.1X authentication settings on the Jetdirect print server as required for client authentication on the network, and reset the 802.1X authentication settings to factory-default values.</p> <p>CAUTION: When changing the 802.1X authentication settings; the printer might lose its connection. To reconnect, it might be necessary to reset the print server to a factory-default state and reinstall the printer.</p>
IPsec/Firewall	View or configure a Firewall policy or an IPsec/Firewall policy.
Announcement Agent	Enable or disable the HP Device Announcement Agent, set the configuration server, and configure mutual authentication using certificates.
Diagnostics	
Network Statistics	Display network statistics that are collected and stored on the HP Jetdirect print server.
Protocol Info	View a list of network-configuration settings on the HP Jetdirect print server for each protocol.
Configuration Page	View the HP Jetdirect configuration page, which contains status and configuration information.

Other Links list

Configure which links display in the footer of the HP Embedded Web Server by using the **Edit Other Links** menu on the **General** tab.

 **NOTE:** The following are the default links.

Table 5-9 HP Embedded Web Server Other Links list

Menu	Description
HP Instant Support	Connect to the HP website to find solutions to printer problems.
Shop for Supplies	Connect to the HP SureSupply website for information on purchasing original HP supplies, such as cartridges and paper.
Product Support	Connect to the support site for the printer to search for help on various topics.

Configure IP network settings



- [Printer sharing disclaimer](#)
- [View or change network settings](#)
- [Rename the printer on a network](#)
- [Manually configure IPv4 TCP/IP parameters from the control panel](#)
- [Manually configure IPv6 TCP/IP parameters from the control panel](#)
- [Link speed and duplex settings](#)

Printer sharing disclaimer

HP does not support peer-to-peer networking, as the feature is a function of Microsoft operating systems and not of the HP printer drivers. Go to Microsoft at www.microsoft.com.

View or change network settings

Use the HP Embedded Web Server to view or change IP configuration settings.



1. Open the HP Embedded Web Server (EWS):
 - a. From the Home screen on the printer control panel, touch the Information  icon, and then touch the Network  icon to display the IP address or host name.
 - b. Open a web browser, and in the address line, type the IP address or host name exactly as it displays on the printer control panel. Press the [Enter](#) key on the computer keyboard. The EWS opens.

 **NOTE:** If the web browser displays a message indicating that accessing the website might not be safe, select the option to continue to the website. Accessing this website will not harm the computer.

2. Click the **Networking** tab to obtain network information. Change settings as needed.

Rename the printer on a network

To rename the printer on a network so that it can be uniquely identified, use the HP Embedded Web Server.

1. Open the HP Embedded Web Server (EWS):
 - a. From the Home screen on the printer control panel, touch the Information  icon, and then touch the Network  icon to display the IP address or host name.
 - b. Open a web browser, and in the address line, type the IP address or host name exactly as it displays on the printer control panel. Press the [Enter](#) key on the computer keyboard. The EWS opens.

 **NOTE:** If the web browser displays a message indicating that accessing the website might not be safe, select the option to continue to the website. Accessing this website will not harm the computer.

2. Open the **General** tab.

3. On the **Device Information** page, the default printer name is in the **Device Name** field. You can change this name to uniquely identify this printer.



NOTE: Completing the other fields on this page is optional.

4. Click the **Apply** button to save the changes.

Manually configure IPv4 TCP/IP parameters from the control panel

Use the control-panel [Settings](#) menus to manually set an IPv4 address, subnet mask, and default gateway.

1. From the Home screen on the printer control panel, navigate to the [Settings](#) application, and then select the [Settings](#) icon.
2. Open the following menus:
 - [Networking](#)
 - [Ethernet](#)
 - [TCP/IP](#)
 - [IPV 4 Settings](#)
 - [Config Method](#)
3. Select the [Manual](#) option, and then touch the [Save](#) button.
4. Open the [Manual Settings](#) menu.
5. Touch the [IP Address](#), [Subnet Mask](#), or [Default Gateway](#) option.
6. Touch the first field to open a keypad. Enter the correct digits for the field, and then touch the [OK](#) button. Repeat the process for each field, and then touch the [Save](#) button.

Manually configure IPv6 TCP/IP parameters from the control panel

Use the control-panel [Settings](#) menus to manually set an IPv6 address.

1. From the Home screen on the printer control panel, navigate to the [Settings](#) application, and then select the [Settings](#) icon.
2. To enable manual configuration, open the following menus:
 - [Networking](#)
 - [Ethernet](#)
 - [TCP/IP](#)
 - [IPV6 Settings](#)
3. Select [Enable](#), and then select [On](#).
4. Select the [Enable Manual Settings](#) option, and then touch the [Done](#) button.
5. To configure the address, open the [Address](#) menu, and then touch the field to open a keypad.

6. Use the keypad to enter the address, and then touch the **OK** button.
7. Touch **Save**.

Link speed and duplex settings

 **NOTE:** This information applies only to Ethernet networks. It does not apply to wireless networks.

The link speed and communication mode of the print server must match the network hub. For most situations, leave the printer in automatic mode. Incorrect changes to the link speed and duplex settings might prevent the printer from communicating with other network devices. To make changes, use the printer control panel.

 **NOTE:** The printer setting must match the setting for the network device (a network hub, switch, gateway, router, or computer).

 **NOTE:** Making changes to these settings causes the printer to turn off and then on. Make changes only when the printer is idle.

1. From the Home screen on the printer control panel, navigate to the **Settings** application, and then select the **Settings** icon.
2. Open the following menus:
 - **Networking**
 - **Ethernet**
 - **Link Speed**
3. Select one of the following options:
 - **Auto:** The print server automatically configures itself for the highest link speed and communication mode allowed on the network.
 - **10T Half:** 10 megabytes per second (Mbps), half-duplex operation
 - **10T Full:** 10 Mbps, full-duplex operation
 - **10T Auto:** 10 Mbps, automatic-duplex operation
 - **100TX Half:** 100 Mbps, half-duplex operation
 - **100TX Full:** 100 Mbps, full-duplex operation
 - **100TX Auto:** 100 Mbps, automatic-duplex operation
 - **1000T Full:** 1000 Mbps, full-duplex operation
4. Touch the **Save** button. The printer turns off and then on.

Printer security features

- [Introduction](#)
- [Security statements](#)
- [Assign an administrator password](#)
- [IP Security](#)
- [Encryption support: HP High Performance Secure Hard Disks](#)
- [Lock the formatter](#)

Introduction

The printer includes several security features to restrict who has access to configuration settings, to secure data, and to prevent access to valuable hardware components.

Security statements



The printer supports security standards and recommended protocols that help you keep the printer secure, protect critical information on your network, and simplify the way you monitor and maintain the printer.

Assign an administrator password

Assign an administrator password for access to the printer and the HP Embedded Web Server so that unauthorized users cannot change the printer settings.

- [Use the HP Embedded Web Server \(EWS\) to set the password](#)
- [Provide user access credentials at the printer control panel](#)

Use the HP Embedded Web Server (EWS) to set the password

1. Open the HP Embedded Web Server (EWS):
 - a. From the Home screen on the printer control panel, touch the Information  icon, and then touch the Network  icon to display the IP address or host name.
 - b. Open a web browser, and in the address line, type the IP address or host name exactly as it displays on the printer control panel. Press the [Enter](#) key on the computer keyboard. The EWS opens.

 **NOTE:** If the web browser displays a message indicating that accessing the website might not be safe, select the option to continue to the website. Accessing this website will not harm the computer.

2. Click the **Security** tab.
3. Open the **General Security** menu.
4. In the area labeled **Set the Local Administrator Password**, enter the name to associate with the password in the **Username** field.
5. Enter the password in the **New Password** field, and then enter it again in the **Verify Password** field.

 **NOTE:** To change an existing password, first enter the existing password in the **Old Password** field.

6. Click the **Apply** button.

 **NOTE:** Make note of the password and store it in a safe place. The administrator password cannot be recovered. If the administrator password is lost or forgotten, contact HP Support at support.hp.com for the assistance required to completely reset the printer.

Provide user access credentials at the printer control panel

Some features on the printer control panel can be secured so that unauthorized people cannot use them. When a feature is secured, the printer prompts you to sign in before you can use it. You can also sign in without waiting for a prompt by selecting [Sign In](#) from the printer control panel.

Typically, the credentials for signing in to the printer are the same as for signing in to the network. Consult the network administrator for this printer if you have questions about which credentials to use.

1. From the Home screen on the printer control panel, select [Sign In](#).
2. Follow the prompts to enter the credentials.

 **NOTE:** To maintain security for the printer, select [Sign Out](#) when you have finished using the printer.

IP Security

IP Security (IPsec) is a set of protocols that control IP-based network traffic to and from the printer. IPsec provides host-to-host authentication, data integrity, and encryption of network communications.

For printers that are connected to the network and have an HP Jetdirect print server, you can configure IPsec by using the **Networking** tab in the HP Embedded Web Server.

Encryption support: HP High Performance Secure Hard Disks

The hard disk provides hardware-based encryption so you can securely store sensitive data without impacting printer performance. This hard disk uses the latest Advanced Encryption Standard (AES) and has versatile time-saving features and robust functionality.

Use the **Security** menu in the HP Embedded Web Server to configure the disk.

Lock the formatter

The formatter has a slot that you can use to attach a security cable. Locking the formatter prevents someone from removing valuable components from it.

Energy-conservation settings

- [Print with EconoMode](#)
- [Set the sleep timer and configure the printer to use 1 watt or less of power](#)

Print with EconoMode

This printer has an EconoMode option for printing drafts of documents. Using EconoMode can use less toner. However, using EconoMode can also reduce print quality.

- [Configure EconoMode from the print driver](#)
- [Configure EconoMode from the printer control panel](#)

HP does not recommend the full-time use of EconoMode. If EconoMode is used full-time, the toner supply might outlast the mechanical parts in the toner cartridge. If print quality begins to degrade and is no longer acceptable, consider replacing the toner cartridge.



NOTE: If this option is not available in the print driver, set it using the printer control panel.

Configure EconoMode from the print driver

1. From the software program, select the **Print** option.
2. Select the printer, and then click the **Properties** or **Preferences** button.
3. Click the **Paper/Quality** tab.
4. Click the **EconoMode** check box to enable the feature, and then click **OK**.

Configure EconoMode from the printer control panel

Use the printer control panel to change the EconoMode setting.

1. From the Home screen on the printer control panel, navigate to the [Settings](#) application, and then select the [Settings](#) icon.
2. Open the following menus:
 - [Copy/Print](#) or [Print](#)
 - [Default Print Options](#)
 - [Economode](#)
3. Select [On](#) or [Off](#) to enable or disable the feature.

Set the sleep timer and configure the printer to use 1 watt or less of power

The sleep settings affect how much power the printer uses, the wake/sleep time, how quickly the printer enters sleep mode, and how quickly the printer wakes up from sleep mode.

To configure the printer to use 1 watt or less of power while in sleep mode, enter times for both the [Sleep after Inactivity](#) and [Auto Off after sleep](#) settings.

1. From the Home screen on the printer control panel, navigate to the [Settings](#) application, and then select the [Settings](#) icon.
2. Open the following menus:

- [General](#)
 - [Energy Settings](#)
 - [Sleep Settings](#)
3. Select [Sleep after Inactivity](#) to specify the number of minutes the printer is inactive before it enters sleep mode. Enter the appropriate time period.
 4. Select [Auto Off after sleep](#) to put the printer into a deeper power save mode after a period of sleep. Enter the appropriate time period.
-
-  **NOTE:** By default, the printer will wake from Auto Off in response to any activity other than USB or Wi-Fi. For greater energy settings, you can set it to wake only to the power button by selecting [Shut down \(wake on power button only\)](#).
-
5. Select [Done](#) to save the settings.

HP Web Jetadmin

HP Web Jetadmin is an award-winning, industry-leading tool for efficiently managing a wide variety of networked HP products, including printers, multifunction printers, and digital senders. This single solution allows you to remotely install, monitor, maintain, troubleshoot, and secure your printing and imaging environment — ultimately increasing business productivity by helping you save time, control costs, and protect your investment.

HP Web Jetadmin upgrades are periodically made available to provide support for specific product features. Go to www.hp.com/go/webjetadmin for more information.

Software and firmware updates

HP regularly updates features that are available in the printer firmware. To take advantage of the most current features, update the printer firmware. Download the most recent firmware update file from the web:

Go to <http://www.hp.com/support/ljE50145>. Click **Drivers & Software**.

6 Solve problems

Troubleshoot problems with the printer. Locate additional resources for help and technical support.

- [Customer support](#)
- [Control panel help system](#)
- [Reset factory settings](#)
- [A “Cartridge is low” or “Cartridge is very low” message displays on the printer control panel](#)
- [Printer does not pick up paper or misfeeds](#)
- [Clear paper jams](#)
- [Resolve print-quality problems](#)

For video assistance, see www.hp.com/videos/LaserJet.

The following information is correct at the time of publication. For current information, see <http://www.hp.com/support/ljE50145>.

For more information:

HP's all-inclusive help for the printer includes the following information:

- Install and configure
- Learn and use
- Solve problems
- Download software and firmware updates
- Join support forums
- Find warranty and regulatory information

Customer support

Get telephone support for your country/region

Country/region phone numbers are on the flyer that was in the box with the printer or at support.hp.com.

Have the printer name, serial number, date of purchase, and problem description ready

Get 24-hour Internet support, and download software utilities and drivers

<http://www.hp.com/support/ljE50145>

Control panel help system

The printer has a built-in Help system that explains how to use each screen. To open the Help system, touch the Help  button on the control panel.

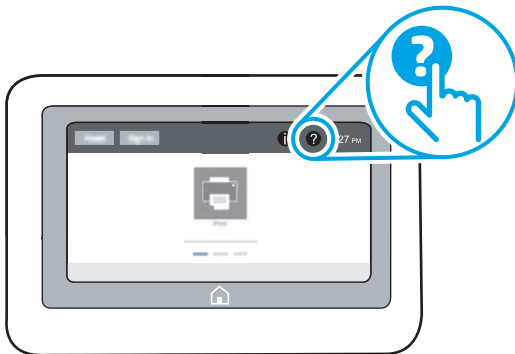

For some screens, the Help opens to a global menu where you can search for specific topics. You can browse through the menu structure by touching the buttons in the menu.

Some Help screens include animations that show specific procedures, such as clearing paper jams.

If the printer alerts of an error or warning, touch the Help  button to open a message that describes the problem. The message also contains instructions to help solve the problem.

Reset factory settings

Resetting the printer settings to the factory-set defaults can help resolve problems.

- [Introduction](#)
- [Method one: Reset factory settings from the printer control panel](#)
- [Method two: Reset factory settings from the HP Embedded Web Server \(network-connected printers only\)](#)

Introduction

Use one of the following methods to reset the printer settings to the original settings from the factory.

Method one: Reset factory settings from the printer control panel

Use the printer control panel to restore the settings to their original values.

1. From the Home screen on the printer control panel, navigate to the [Settings](#) application, and then select the [Settings](#) icon.
2. Open the following menus:
 - [General](#)
 - [Reset Factory Settings](#)
3. Select [Reset](#).

A verification message advises that completing the reset function might result in loss of data.



4. Select [Reset](#) to complete the process.



NOTE: The printer restarts automatically after the reset operation completes.

Method two: Reset factory settings from the HP Embedded Web Server (network-connected printers only)

Use the HP EWS to reset the printer settings to the original settings.

1. On the printer control panel, select the Information  button, and then select the Network  icon to display the IP address or host name.
2. Open the **General** tab.
3. On the left side of the screen, click **Reset Factory Settings**.
4. Click the **Reset** button.



NOTE: The printer restarts automatically after the reset operation completes.

A “Cartridge is low” or “Cartridge is very low” message displays on the printer control panel

Cartridge is low: The printer indicates when a toner cartridge level is low. Actual toner cartridge life remaining may vary. Consider having a replacement available to install when print quality is no longer acceptable. The toner cartridge does not need to be replaced now.

Cartridge is very low: The printer indicates when the toner cartridge level is very low. Actual toner cartridge life remaining may vary. Consider having a replacement available to install when print quality is no longer acceptable. The toner cartridge does not need to be replaced now unless the print quality is no longer acceptable.

HP’s Premium Protection Warranty expires near the end of useable cartridge life. Check the Supplies Status Page or the HP Embedded Web Server (EWS) for the status.

Printer does not pick up paper or misfeeds

- [Introduction](#)
- [The printer does not pick up paper](#)
- [The printer picks up multiple sheets of paper](#)

Introduction

The following solutions can help solve problems if the printer is not picking up paper from the tray or is picking up multiple sheets of paper at one time. Either of these situations can result in paper jams.

The printer does not pick up paper

If the printer does not pick up paper from the tray, try these solutions.

1. Open the printer and remove any jammed sheets of paper. Verify that no torn remnants of paper remain inside the printer.
2. Load the tray with the correct size of paper for the job.
3. Make sure the paper size and type are set correctly on the printer control panel.

4. Make sure the paper guides in the tray are adjusted correctly for the size of paper. Adjust the guides to the appropriate indentation in the tray. The arrow on the tray guide should line up exactly with the marking on the tray.

 **NOTE:** Do not adjust the paper guides tightly against the paper stack. Adjust them to the indentations or markings in the tray.

The following images show examples of the paper-size indentations in the trays for various printers. Most HP printers have markings similar to these.

Figure 6-1 Size markings for Tray 1 or the multipurpose tray

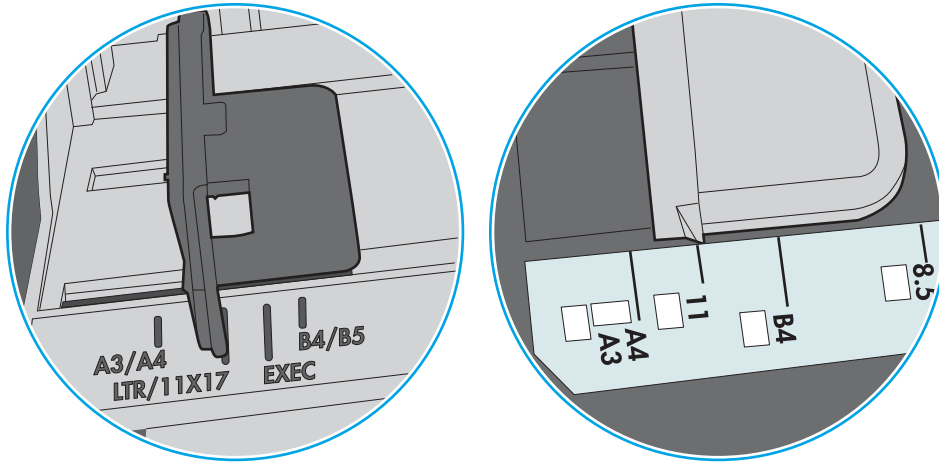
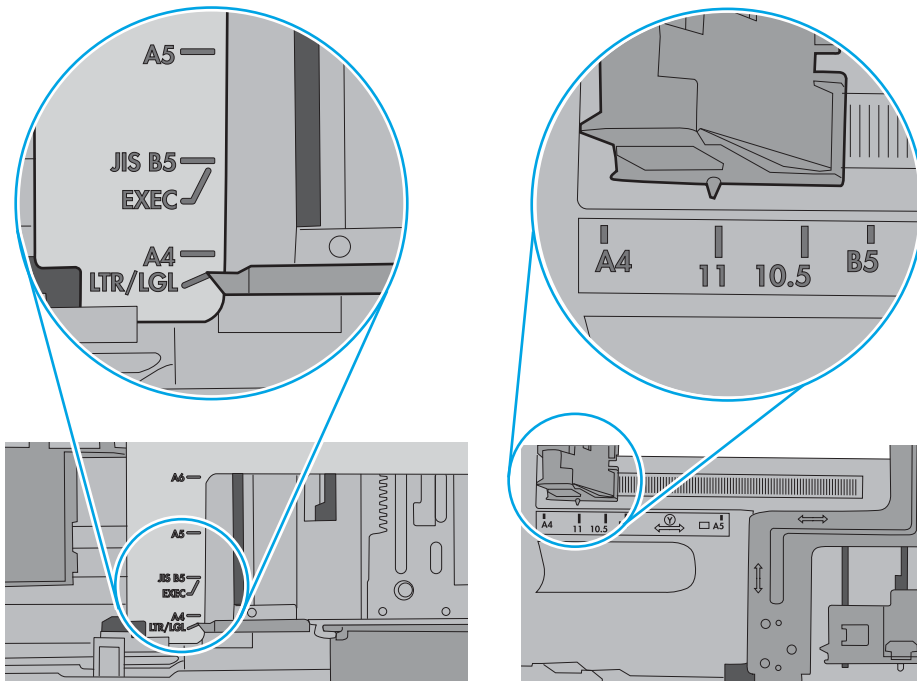

Figure 6-2 Size markings for cassette trays



5. Verify that the humidity in the room is within specifications for this printer and that paper is being stored in unopened packages. Most reams of paper are sold in moisture-proof wrapping to keep paper dry.

In high-humidity environments, paper at the top of the stack in the tray can absorb moisture, and it might have a wavy or uneven appearance. If this happens, remove the top 5 to 10 sheets of paper from the stack.

In low-humidity environments, excess static electricity can cause sheets of paper to stick together. If this happens, remove the paper from the tray, and flex the stack by holding it at each end and bringing the ends up to form a U shape. Then, rotate the ends down to reverse the U shape. Next, hold each side of the stack of paper, and repeat this process. This process releases individual sheets without introducing static electricity. Straighten the paper stack against a table before returning it to the tray.

Figure 6-3 Technique for flexing the paper stack

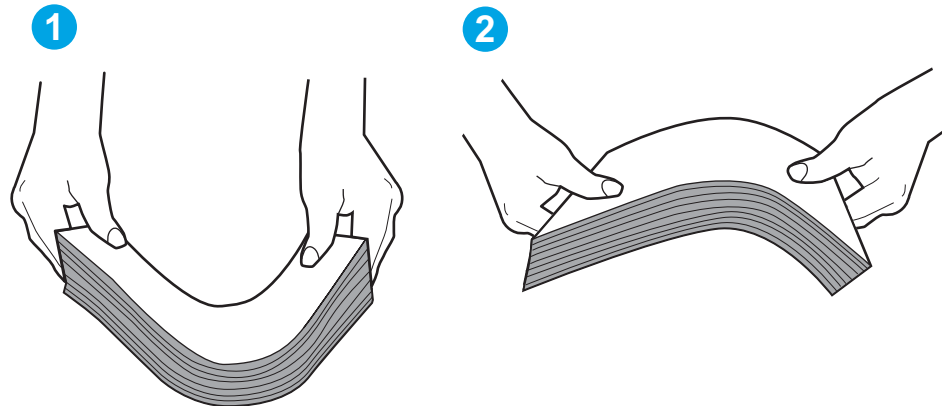

6. Check the printer control panel to see if it is displaying a prompt to feed the paper manually. Load paper, and continue.
7. The rollers above the tray might be contaminated. Clean the rollers with a lint-free cloth dampened with warm water. Use distilled water, if it is available.

CAUTION: Do not spray water directly on to the printer. Instead, spray water on the cloth or dab the cloth in water and wring it out before cleaning the rollers.

The following image shows examples of the roller location for various printers.

Figure 6-4 Roller locations for Tray 1 or the multipurpose tray

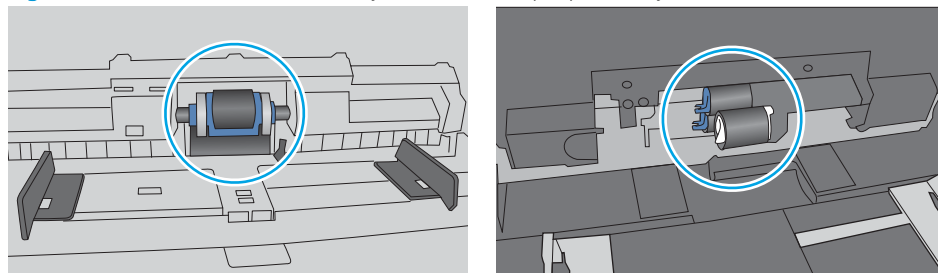

The printer picks up multiple sheets of paper

If the printer picks up multiple sheets of paper from the tray, try these solutions.

1. Remove the stack of paper from the tray and flex it, rotate it 180 degrees, and flip it over. *Do not fan the paper.* Return the stack of paper to the tray.

 **NOTE:** Fanning the paper introduces static electricity. Instead of fanning the paper, flex the stack by holding it at each end and bringing the ends up to form a U shape. Then, rotate the ends down to reverse the U shape. Next, hold each side of the stack of paper, and repeat this process. This process releases individual sheets without introducing static electricity. Straighten the paper stack against a table before returning it to the tray.

Figure 6-5 Technique for flexing the paper stack



2. Use only paper that meets HP specifications for this printer.
3. Verify that the humidity in the room is within specifications for this printer, and that paper is being stored in unopened packages. Most reams of paper are sold in moisture-proof wrapping to keep paper dry.

In high-humidity environments, paper at the top of the stack in the tray can absorb moisture, and it might have a wavy or uneven appearance. If this happens, remove the top 5 to 10 sheets of paper from the stack.

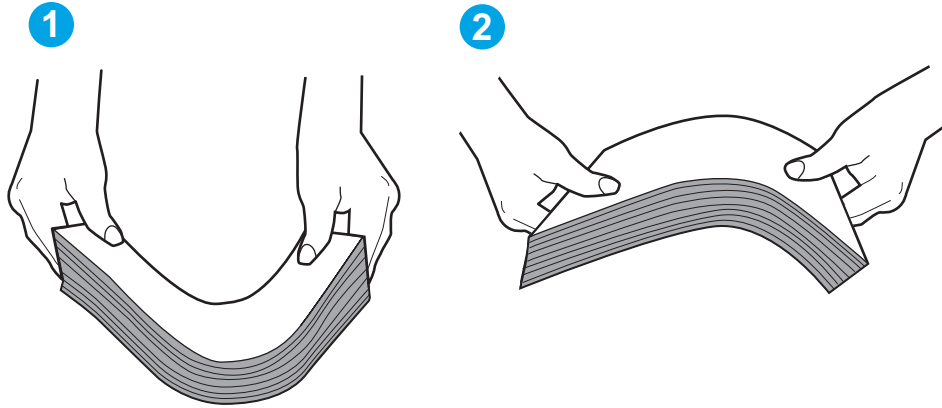
In low-humidity environments, excess static electricity can cause sheets of paper to stick together. If this happens, remove the paper from the tray, and flex the stack as described above.

4. Use paper that is not wrinkled, folded, or damaged. If necessary, use paper from a different package.

5. Make sure the tray is not overfilled by checking the stack-height markings inside the tray. If it is overfilled, remove the entire stack of paper from the tray, straighten the stack, and then return some of the paper to the tray.

The following images show examples of the stack-height markings in the trays for various printers. Most HP printers have markings similar to these. Also make sure that all sheets of paper are below the tabs near the stack-height marks. These tabs help hold the paper in the correct position as it enters the printer.

Figure 6-6 Stack-height markings

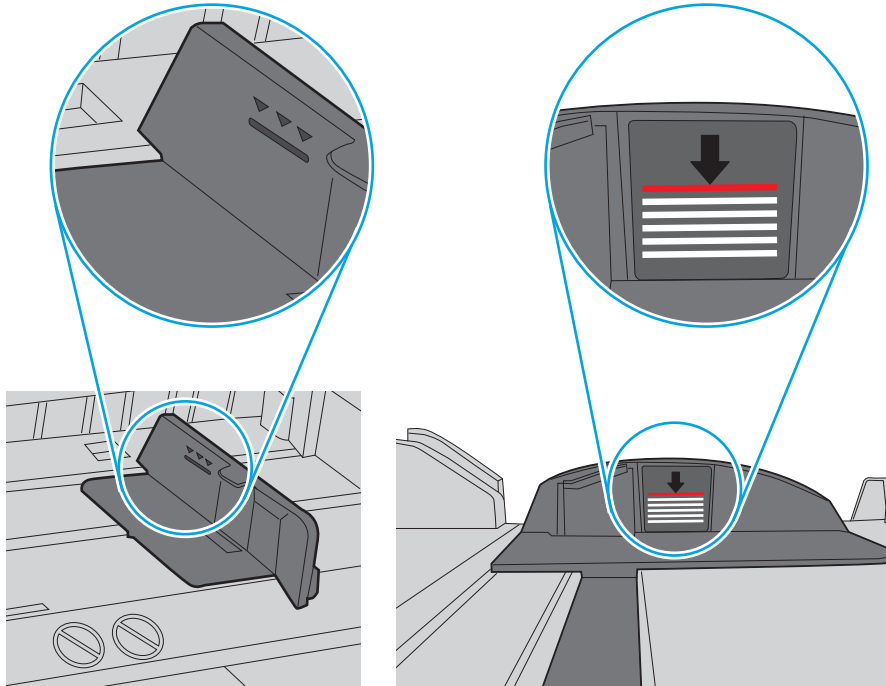
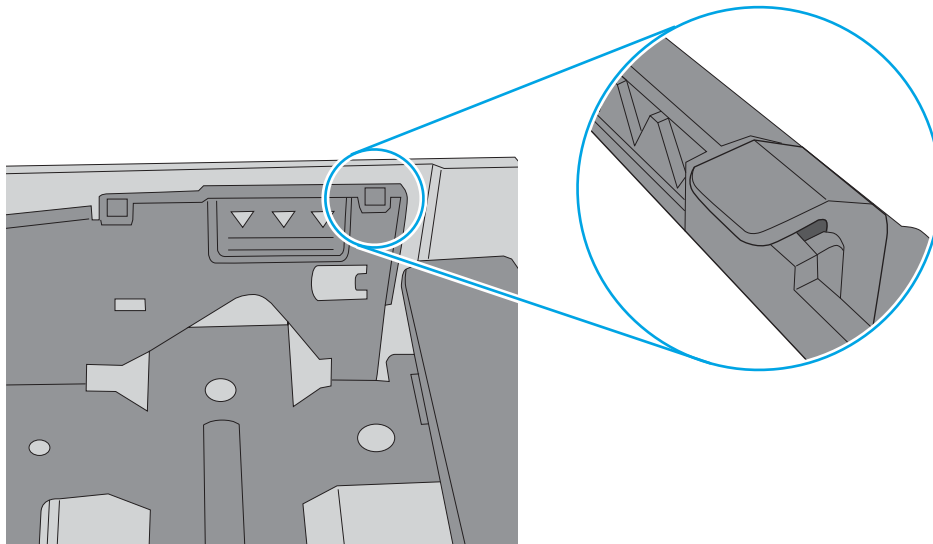

Figure 6-7 Tab for the paper stack



6. Make sure the paper guides in the tray are adjusted correctly for the size of paper. Adjust the guides to the appropriate indentation in the tray. The arrow on the tray guide should line up exactly with the marking on the tray.

 **NOTE:** Do not adjust the paper guides tightly against the paper stack. Adjust them to the indentations or markings in the tray.

The following images show examples of the paper-size indentations in the trays for various printers. Most HP printers have markings similar to these.

Figure 6-8 Size markings for Tray 1 or the multipurpose tray

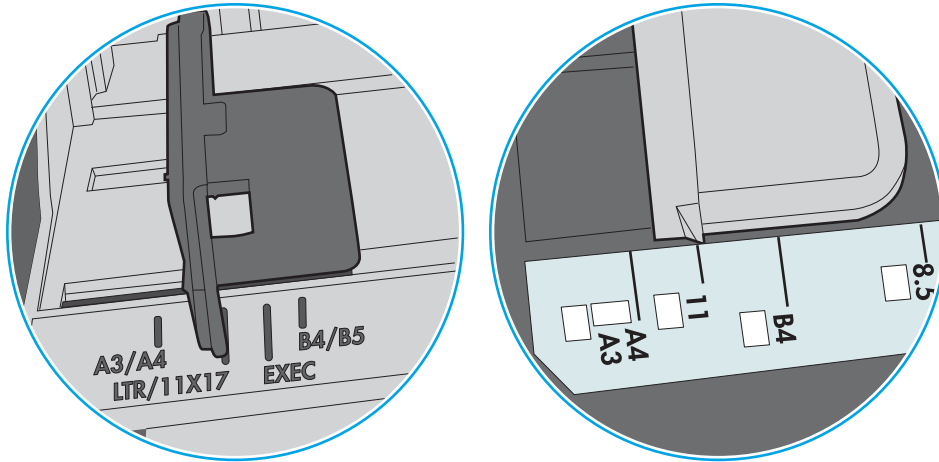
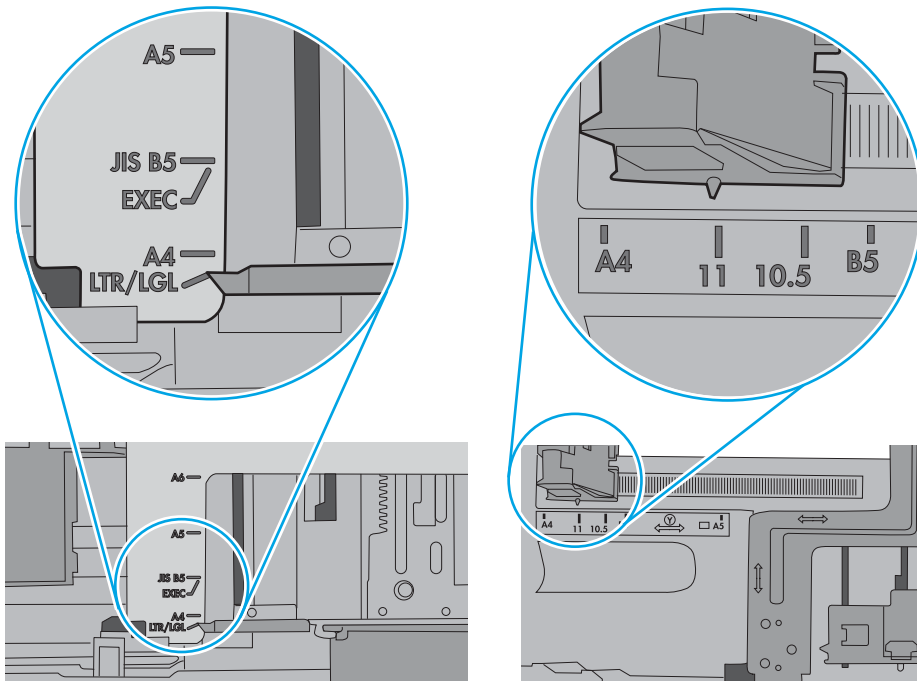

Figure 6-9 Size markings for cassette trays



7. Make sure the printing environment is within recommended specifications.

Clear paper jams

- [Introduction](#)
- [Paper jam locations](#)
- [Auto-navigation for clearing paper jams](#)
- [Experiencing frequent or recurring paper jams?](#)
- [Clear paper jams in tray 1—13.A1](#)
- [Clear paper jams in tray 2, tray 3, tray 4, tray 5—13.A2, 13.A3, 13.A4, 13.A5](#)
- [Clear paper jams in the output bin—13.E1](#)
- [Clear paper jams in the duplexer—13.CX.XX, 13.DX.XX](#)
- [Clear paper jams in the toner-cartridge area](#)
- [Clear paper jams in the fuser—13.B9, 13.B2, 13.FF](#)

Introduction

The following information includes instructions for clearing paper jams from the printer.

Paper jam locations

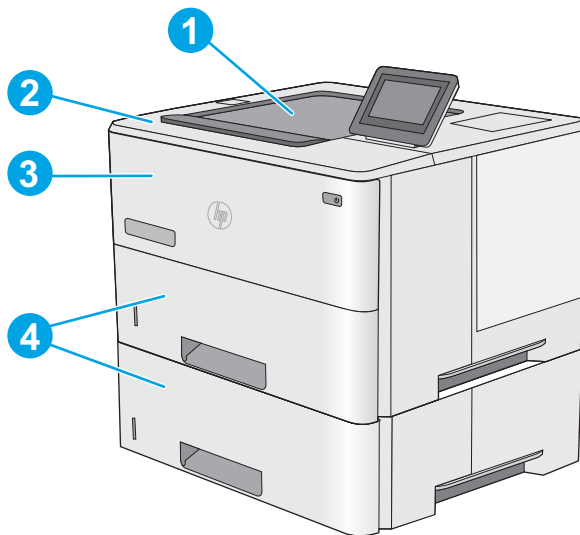

1	Output bin
2	Top cover and toner-cartridge area
3	Tray 1
4	Tray 2 and the optional 1 x 550-sheet feeders

NOTE: Remove Tray 2 to access jams in the duplexer.

Auto-navigation for clearing paper jams

The auto-navigation feature assists in clearing jams by providing step-by-step instructions on the control panel. When you complete a step, the printer displays instructions for the next step until you have completed all steps in the procedure.

Experiencing frequent or recurring paper jams?

To reduce the number of paper jams, try these solutions.



NOTE: To see a video that demonstrates how to load paper in a way that reduces the number of paper jams, click [here](#).

1. Use only paper that meets HP specifications for this printer.
2. Use paper that is not wrinkled, folded, or damaged. If necessary, use paper from a different package.
3. Use paper that has not previously been printed or copied on.
4. Make sure the tray is not overfilled. If it is, remove the entire stack of paper from the tray, straighten the stack, and then return some of the paper to the tray.
5. Make sure the paper guides in the tray are adjusted correctly for the size of paper. Adjust the guides so they are touching the paper stack without bending it.
6. Make sure that the tray is fully inserted in the printer.
7. If you are printing on heavy, embossed, or perforated paper, use the manual feed feature and feed sheets one at a time.
8. Open the **Trays** menu on the printer control panel. Verify that the tray is configured correctly for the paper type and size.
9. Make sure the printing environment is within recommended specifications.

Clear paper jams in tray 1—13.A1

Use the following procedure to clear paper jams in Tray 1. When a jam occurs, the control panel displays an animation that assists in clearing the jam.

1. If most of the sheet of paper is visible in the tray, slowly pull the jammed paper out of the printer. Make sure that the entire sheet is removed. If it tears, continue with the following steps to find the remnants.

If most of the sheet of paper has been pulled inside the printer, continue with the following steps.

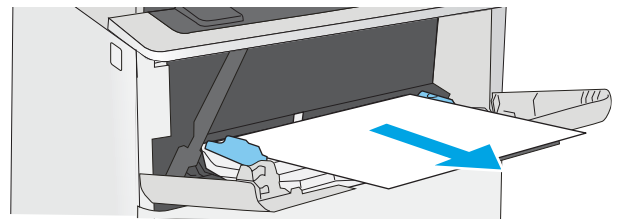

2. Press the top-cover-release button on the left side of the printer.

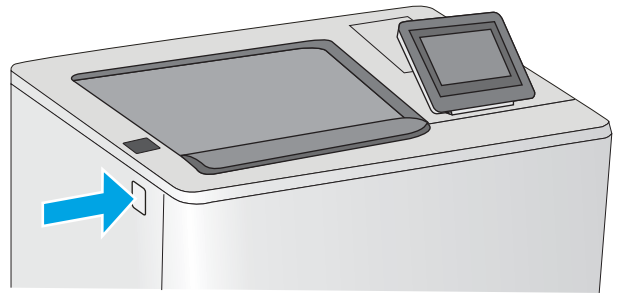

3. Open the front door.

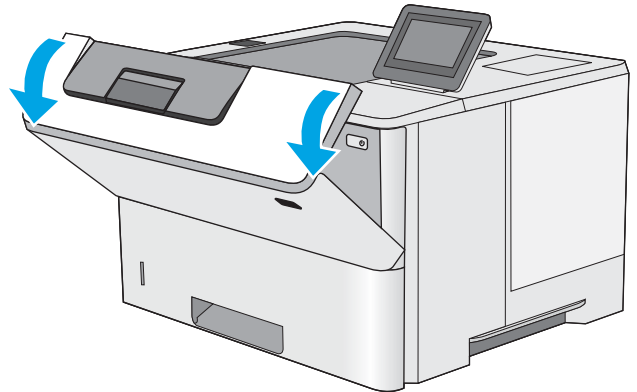

4. Remove the toner cartridge.

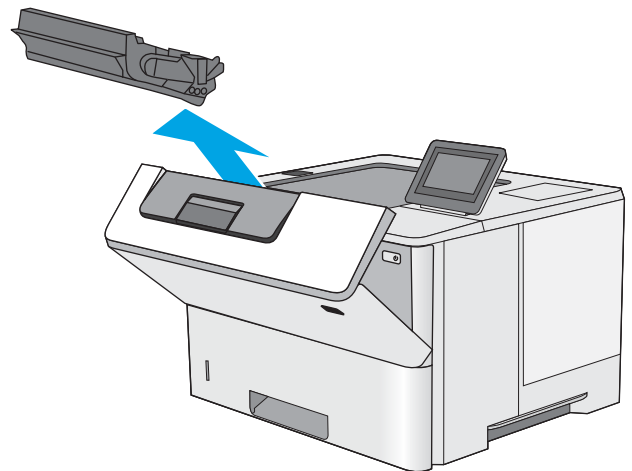

- 5. Lift the jam-access cover and slowly remove any jammed paper. Be careful not to tear the paper.

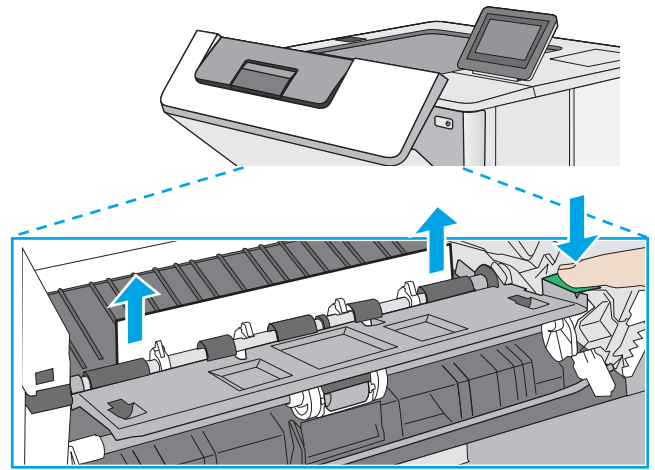

- 6. Reinsert the toner cartridge.

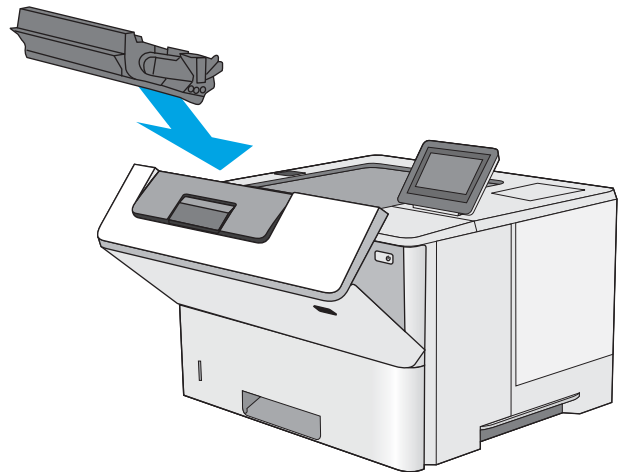

- 7. Close the front door.

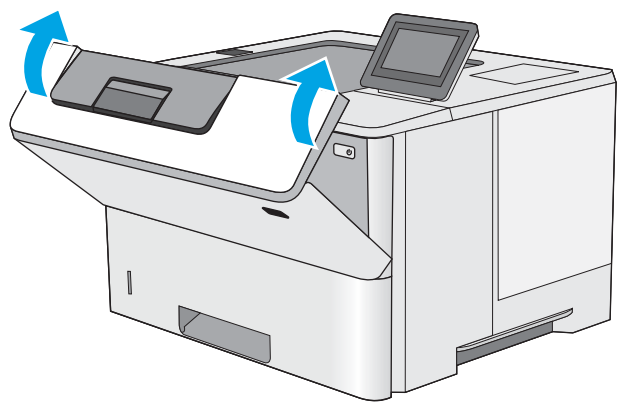

Clear paper jams in tray 2, tray 3, tray 4, tray 5—13.A2, 13.A3, 13.A4, 13.A5

Use the following procedure to check for paper in all possible jam locations related to Tray 2 and the 550-sheet trays. When a jam occurs, the control panel displays an animation that assists in clearing the jam.

1. Remove the tray from the printer.

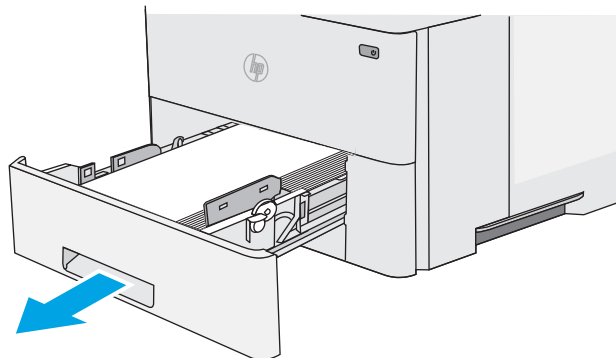

2. Remove the paper from the tray, and discard any damaged paper.

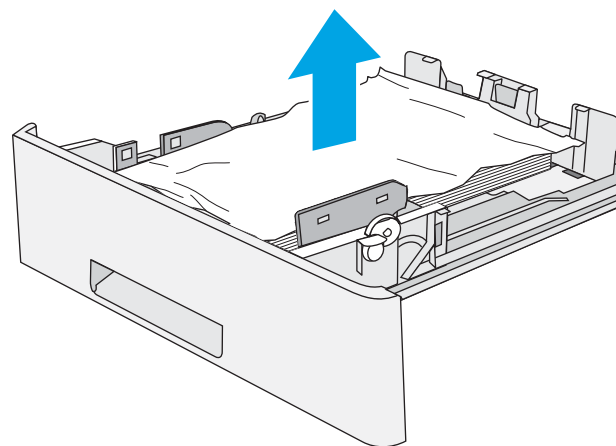

3. Verify that the rear paper guide is adjusted to the indentation for the correct paper size. If necessary, pinch the release and move the rear paper guide to the correct position. It should click into place.

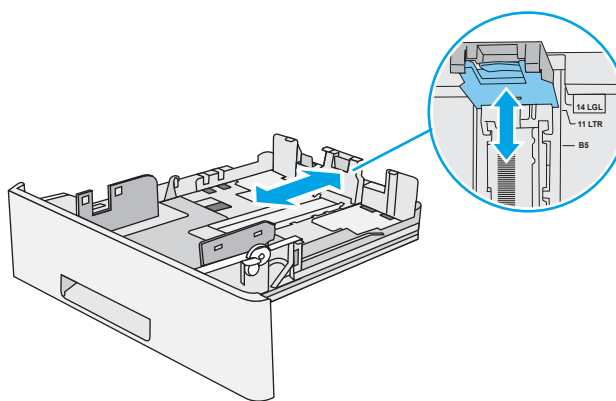

4. Load the paper into the tray. Make sure that the stack is flat at all four corners and that the top of the stack is below the maximum-height indicators.

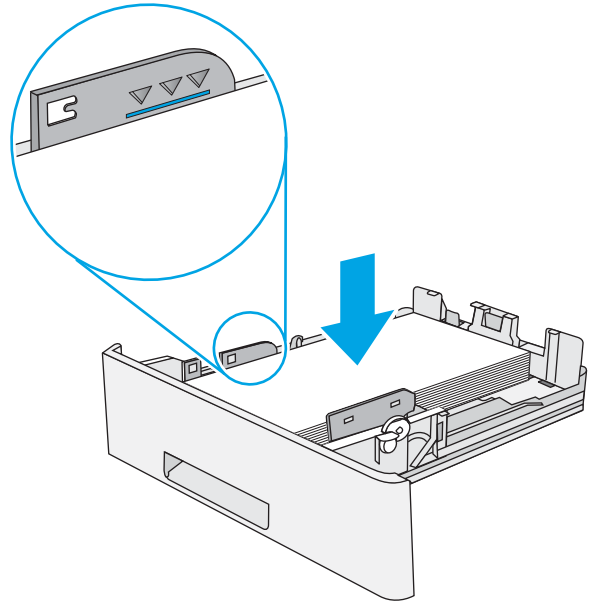

5. Reinsert and close the tray.

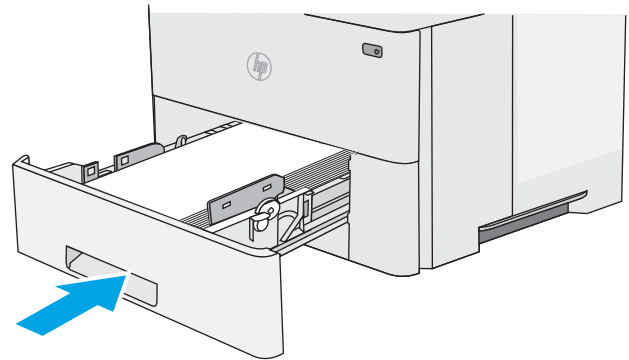

6. Press the top-cover-release button on the left side of the printer.

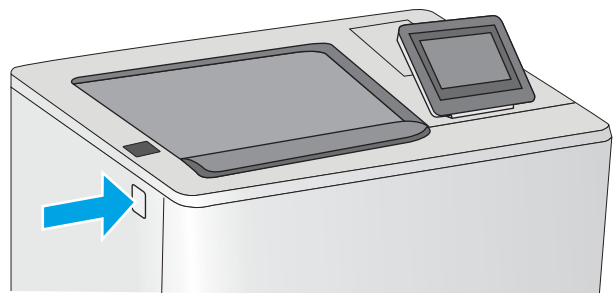

7. Open the front door.

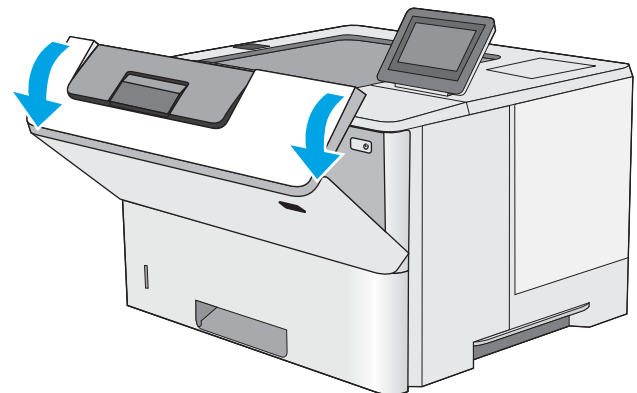

8. Remove the toner cartridge.

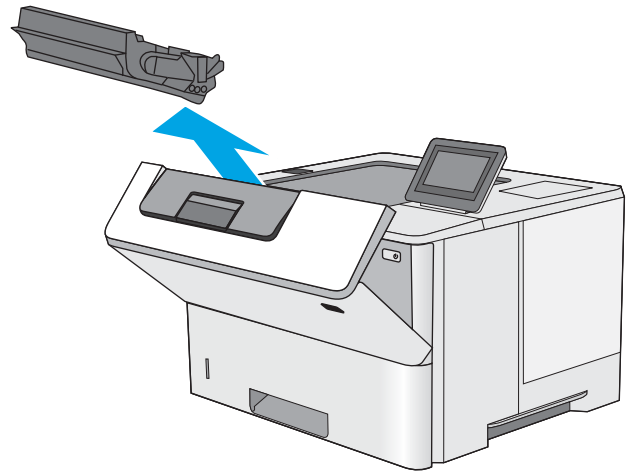

9. Lift the jam-access cover and slowly remove any jammed paper. Be careful not to tear the paper.

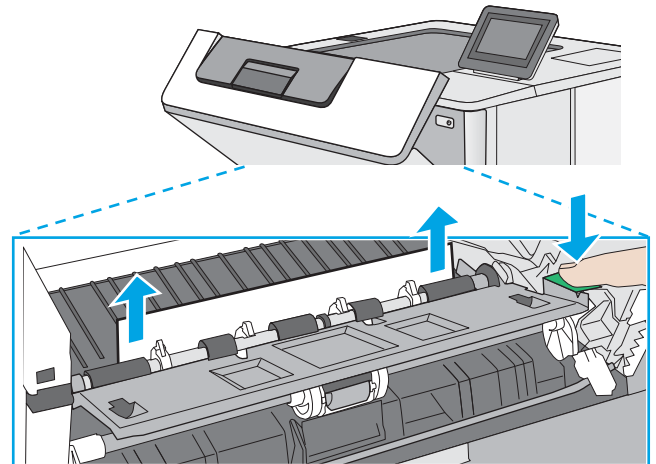

10. Reinsert the toner cartridge.

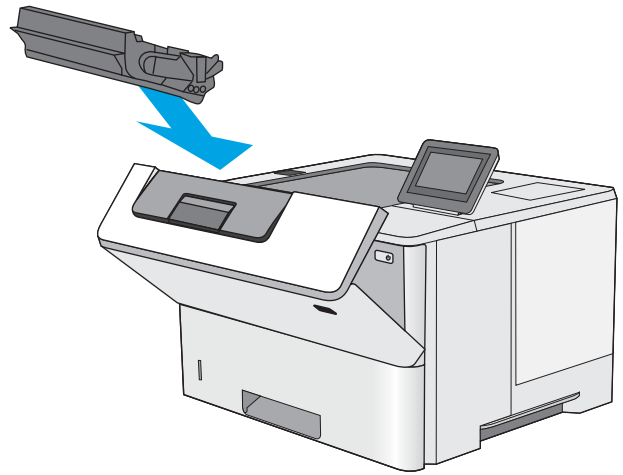

11. Close the front door.

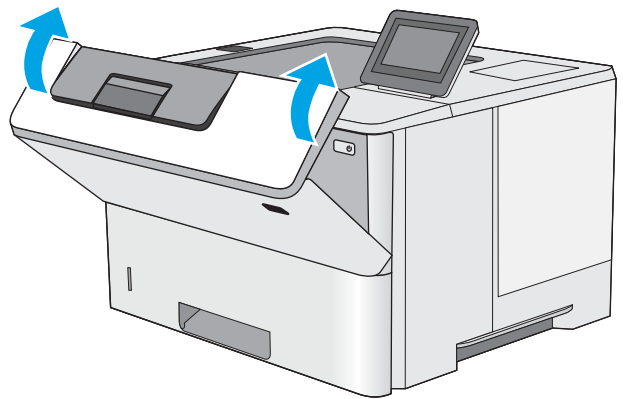

Clear paper jams in the output bin—13.E1

Use the following procedure to check for paper in all possible jam locations in the output bin. When a jam occurs, the control panel displays an animation that assists in clearing the jam.

1. If paper is visible in the output bin, grasp the leading edge and remove it.

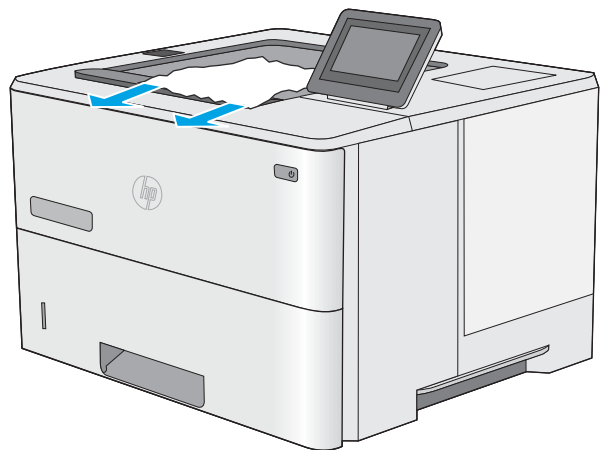

Clear paper jams in the duplexer—13.CX.XX, 13.DX.XX

Use the following procedure to check for paper in all possible jam locations in the automatic duplexer. When a jam occurs, the control panel displays an animation that assists in clearing the jam.

1. Remove Tray 2 from the printer.

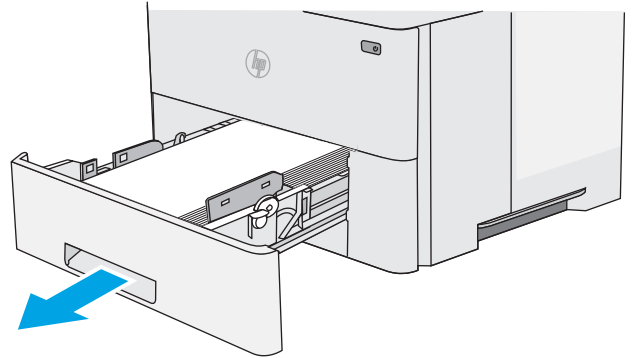

2. Pull forward on the green tab inside the tray area to release the duplex pan.

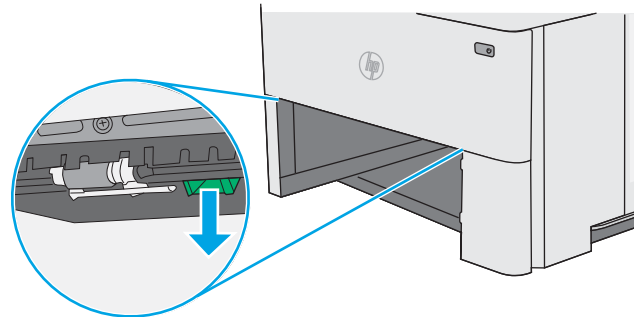

3. Remove any jammed paper.

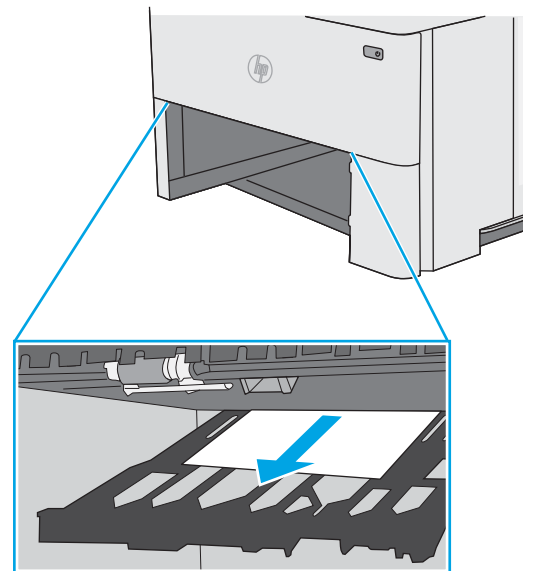

4. Close the duplex pan.

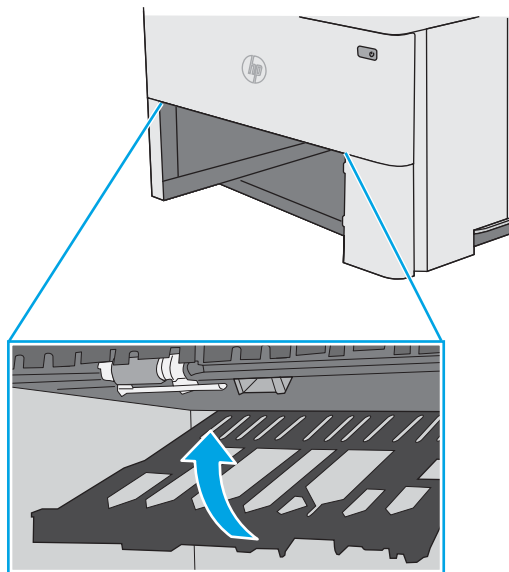

5. Reinsert and close the tray.

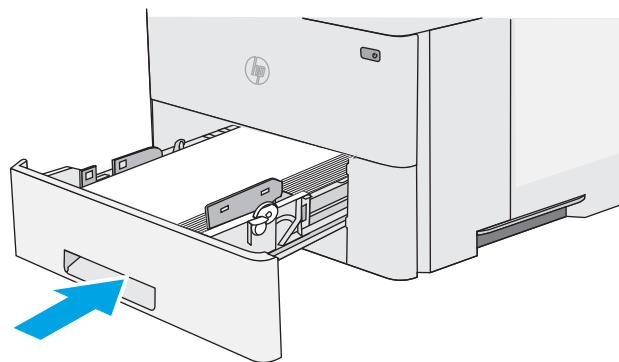

6. Open the rear door.

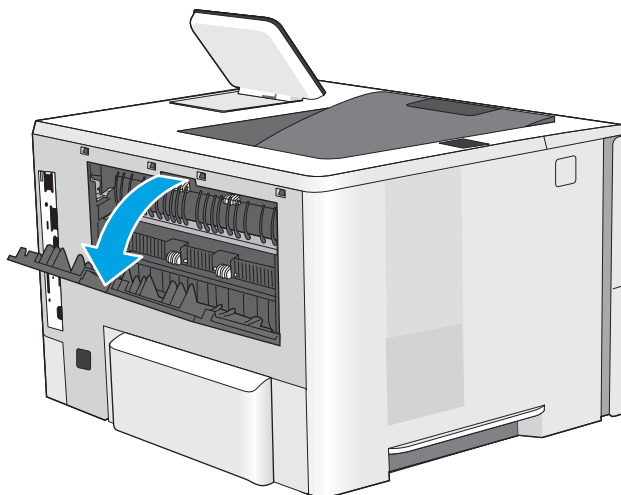

7. Remove any jammed paper.

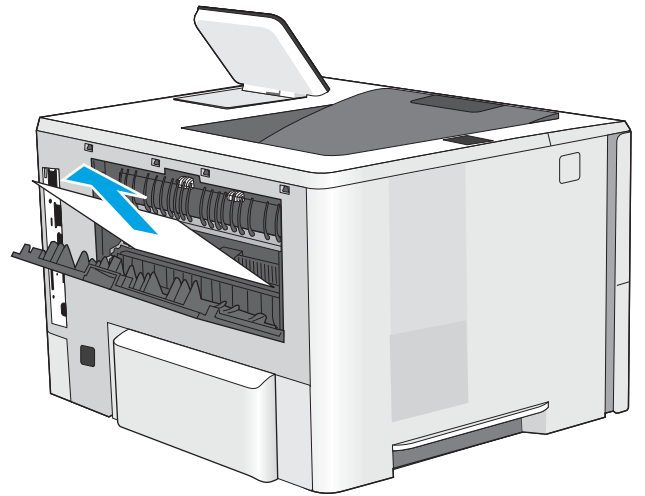

8. Close the rear door

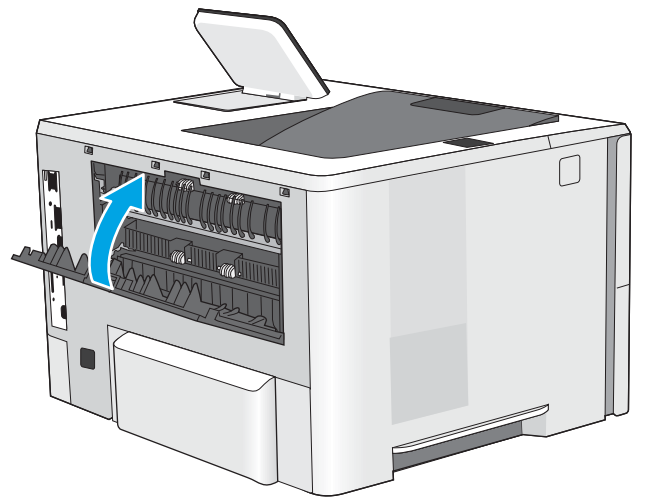

9. Press the top-cover-release button on the left side of the printer.

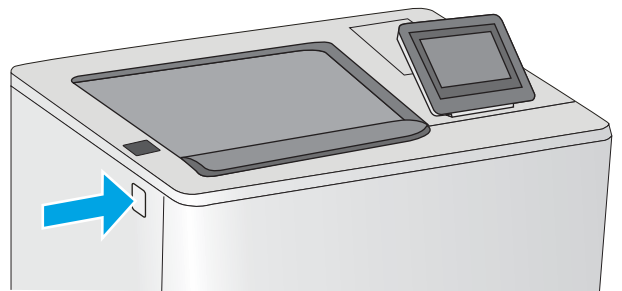

10. Open the front door.

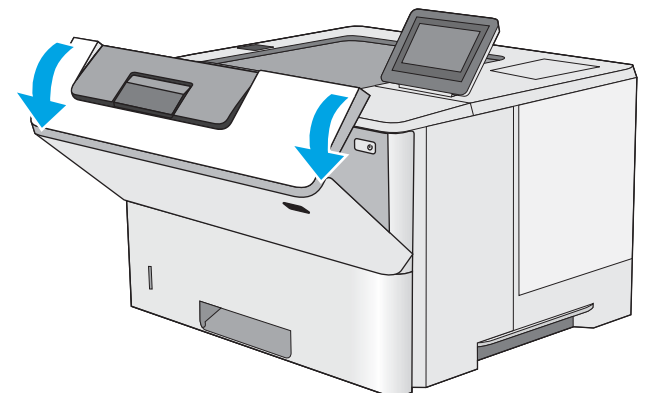

11. Remove the toner cartridge.

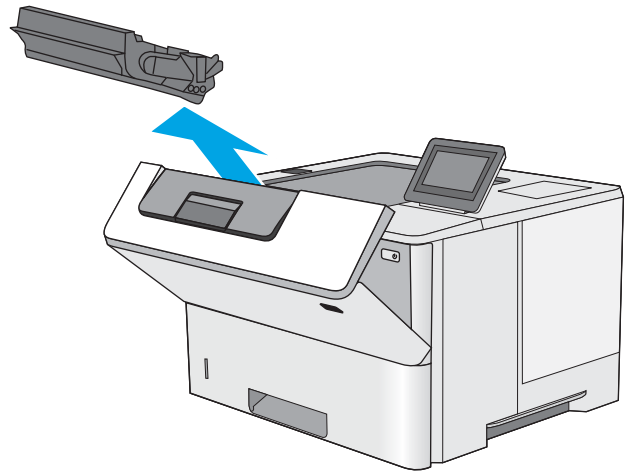

12. Lift the jam-access cover and slowly remove any jammed paper. Be careful not to tear the paper.

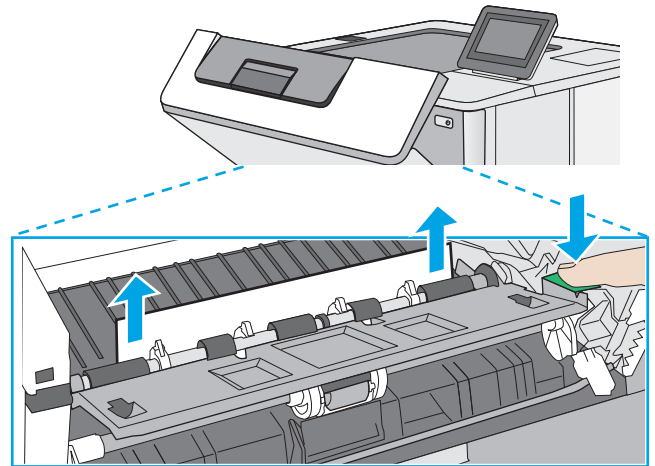

13. Reinsert the toner cartridge.

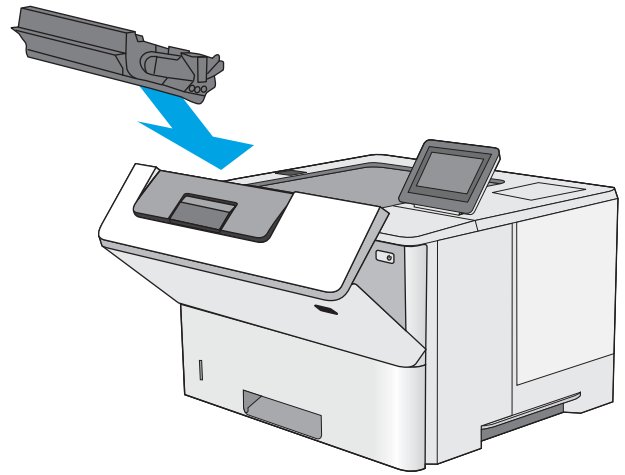

14. Close the front door.

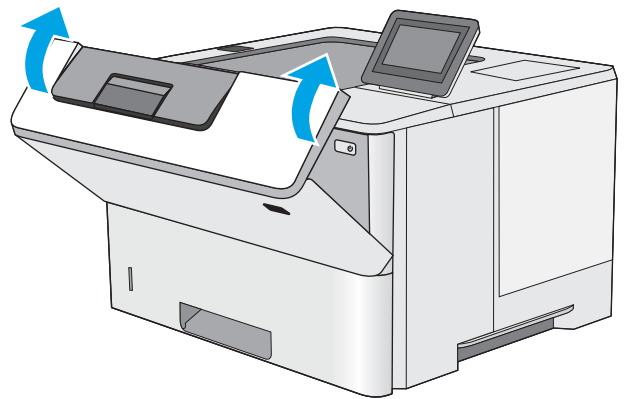

Clear paper jams in the toner-cartridge area

Use the following procedure to check for paper in all possible jam locations in the toner-cartridge area. When a jam occurs, the control panel displays an animation that assists in clearing the jam.

1. Press the top-cover-release button on the left side of the printer.

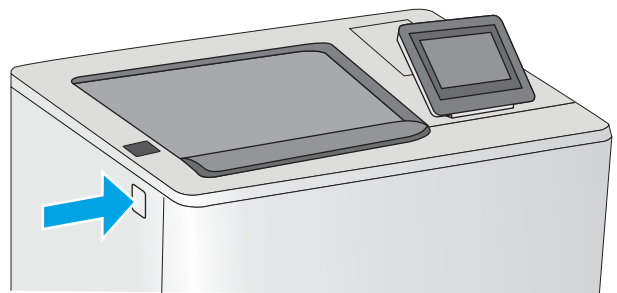

2. Open the front door.

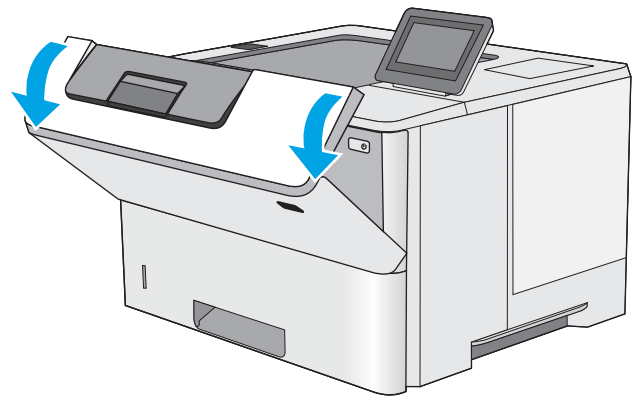

3. Remove the toner cartridge.

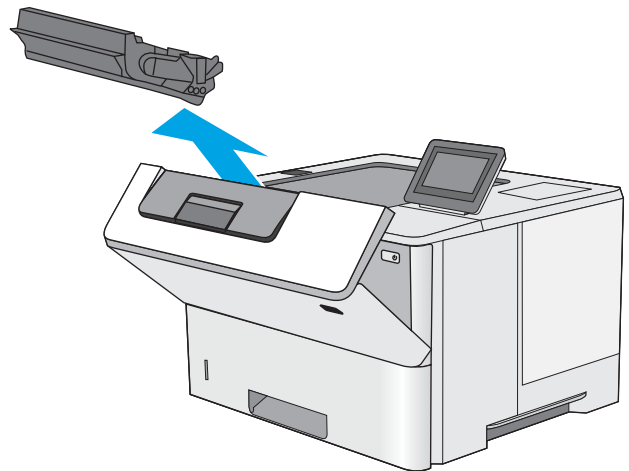

4. Lift the jam-access cover and slowly remove any jammed paper. Be careful not to tear the paper.

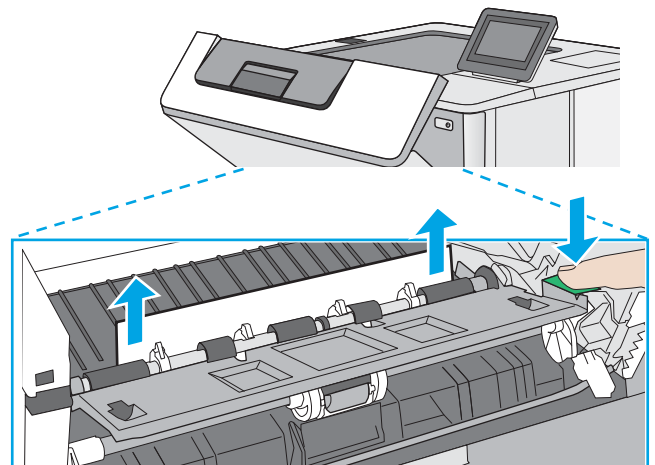

5. Reinsert the toner cartridge.

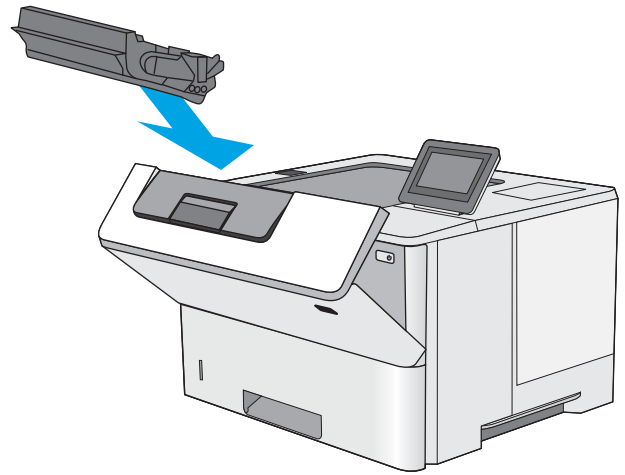

6. Close the front door.

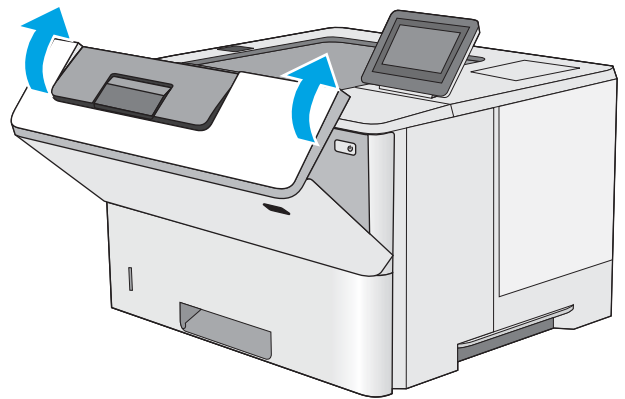

Clear paper jams in the fuser—13.B9, 13.B2, 13.FF

Use the following procedure to clear paper jams in the rear door and fuser area. When a jam occurs, the control panel displays an animation that assists in clearing the jam.

 **NOTE:** The fuser is hot while the printer is in use. Wait for the fuser to cool before clearing jams.

1. Open the rear door.

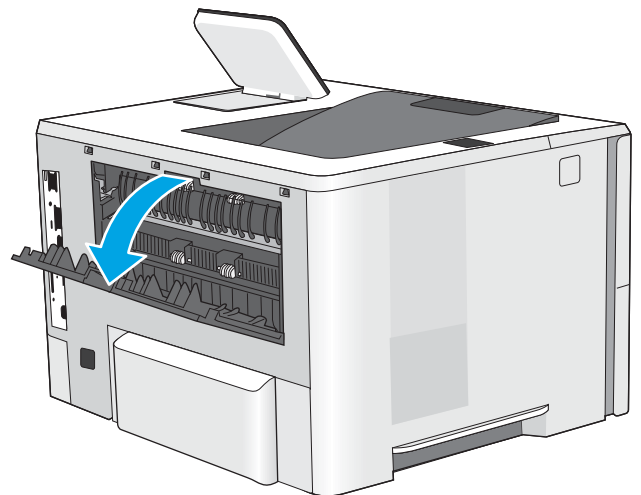

2. Remove any jammed paper.

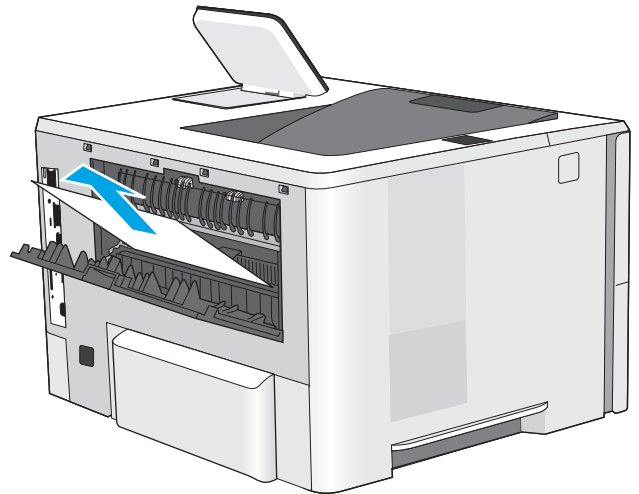

3. Close the rear door

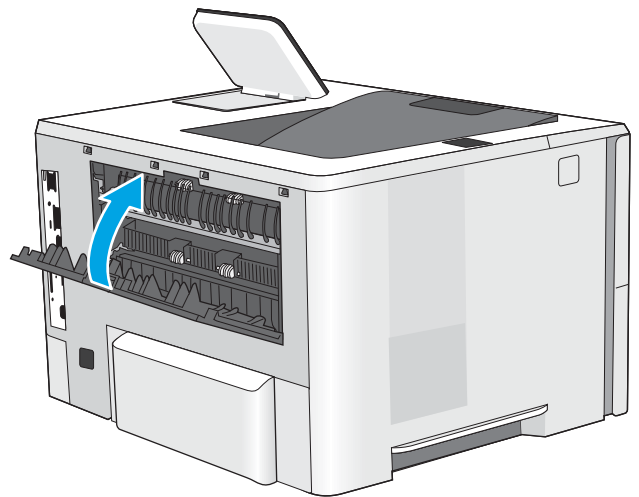

Resolve print-quality problems

- [Introduction](#)
- [Troubleshoot print quality](#)

Introduction

Use the information below to troubleshoot print-quality problems, including issues with image quality.

The troubleshooting steps can help resolve the following defects:

- Blank pages
- Black pages
- Curled paper
- Dark or light bands
- Dark or light streaks
- Fuzzy print
- Gray background or dark print
- Light print
- Loose toner
- Missing toner
- Scattered dots of toner
- Skewed images
- Smears
- Streaks

Troubleshoot print quality

To resolve print-quality issues, try these steps in the order presented.

- [Print from a different software program](#)
- [Check the paper-type setting for the print job](#)
- [Check toner-cartridge status](#)
- [Print a cleaning page](#)
- [Visually inspect the toner cartridge or cartridges](#)
- [Check paper and the printing environment](#)
- [Try a different print driver](#)
- [Troubleshoot image defects](#)

To troubleshoot specific image defects, see [Troubleshoot Image Defects](#).

Print from a different software program

Try printing from a different software program. If the page prints correctly, the problem is with the software program from which you were printing.

Check the paper-type setting for the print job

Check the paper type setting when printing from a software program and the printed pages have smears, fuzzy or dark print, curled paper, scattered dots of toner, loose toner, or small areas of missing toner.

- [Check the paper type setting on the printer](#)
- [Check the paper type setting \(Windows\)](#)
- [Check the paper type setting \(macOS\)](#)

Check the paper type setting on the printer

Check the paper type setting on the printer control panel, and change the setting as needed.

1. Open the tray.
2. Verify that the tray is loaded with the correct type of paper.
3. Close the tray.
4. Follow the control panel instructions to confirm or modify the paper type settings for the tray.

Check the paper type setting (Windows)

Check the paper type setting for Windows, and change the setting as needed.

1. From the software program, select the **Print** option.
2. Select the printer, and then click the **Properties** or **Preferences** button.
3. Click the **Paper/Quality** tab.
4. From the **Paper Type** drop-down list, click the **More...** option.
5. Expand the list of **Type is:** options.
6. Expand the category of paper types that best describes your paper.
7. Select the option for the type of paper you are using, and click the **OK** button.
8. Click the **OK** button to close the **Document Properties** dialog box. In the **Print** dialog box, click the **OK** button to print the job.

Check the paper type setting (macOS)

Check the paper type setting for macOS, and change the setting as needed.

1. Click the **File** menu, and then click the **Print** option.
2. In the **Printer** menu, select the printer.
3. By default, the print driver displays the **Copies & Pages** menu. Open the menus drop-down list, and then click the **Paper/Quality** menu.
4. Select a type from the **Media Type** drop-down list.
5. Click the **Print** button.

Check toner-cartridge status

Follow these steps to check the estimated life remaining in the toner cartridges and if applicable, the status of other replaceable maintenance parts.

- [Step one: Print the supplies status page](#)
- [Step two: Check supplies status](#)

Step one: Print the supplies status page

The supplies status page indicates the cartridge status.

1. From the Home screen on the printer control panel, navigate to the [Reports](#) application, and then select the [Reports](#) icon.
2. Select the [Configuration/Status Pages](#) menu.
3. Select [Supplies Status Page](#), and then select [Print](#) to print the page.

Step two: Check supplies status

1. Look at the supplies status report to check the percent of life remaining for the toner cartridges and, if applicable, the status of other replaceable maintenance parts.

Print quality problems can occur when using a toner cartridge that is at its estimated end of life. The supplies status page indicates when a supply level is very low. After an HP supply has reached the very low threshold, HP's premium protection warranty on that supply has ended.

The toner cartridge does not need to be replaced now unless the print quality is no longer acceptable. Consider having a replacement available to install when print quality is no longer acceptable.

If you determine that you need to replace a toner cartridge or other replaceable maintenance parts, the supplies status page lists the genuine HP part numbers.

2. Check to see if you are using a genuine HP cartridge.

A genuine HP toner cartridge has the word "HP" on it, or has the HP logo on it. For more information on identifying HP cartridges go to www.hp.com/go/learnaboutsupplies.

Print a cleaning page

During the printing process paper, toner, and dust particles can accumulate inside the printer and can cause print-quality issues such as toner specks or spatter, smears, streaks, lines, or repeating marks.

Follow these steps to clean the printer paper path.

1. From the Home screen on the printer control panel, navigate to the [Support Tools](#) application, and then select the [Support Tools](#) icon.
2. Select the following menus:

- [Maintenance](#)
 - [Calibration/Cleaning](#)
 - [Cleaning Page](#)
3. Select [Print](#) to print the page.

A **Cleaning...** message displays on the printer control panel. The cleaning process takes a few minutes to complete. Do not turn the printer off until the cleaning process has finished. When it is finished, discard the printed page.

Visually inspect the toner cartridge or cartridges

Follow these steps to inspect each toner cartridge.

1. Remove the toner cartridges from the printer.
2. Check the memory chip for damage.
3. Examine the surface of the green imaging drum.

 **CAUTION:** Do not touch the imaging drum. Fingerprints on the imaging drum can cause print-quality problems.

4. If you see any scratches, fingerprints, or other damage on the imaging drum, replace the toner cartridge.
5. Reinstall the toner cartridge, and print a few pages to see if the problem has resolved.

Check paper and the printing environment

- [Step one: Use paper that meets HP specifications](#)
- [Step two: Check the environment](#)
- [Step three: Set the individual tray alignment](#)

Step one: Use paper that meets HP specifications

Some print-quality problems arise from using paper that does not meet HP specifications.

- Always use a paper type and weight that this printer supports.
- Use paper that is of good quality and free of cuts, nicks, tears, spots, loose particles, dust, wrinkles, voids, staples, and curled or bent edges.
- Use paper that has not been previously printed on.
- Use paper that does not contain metallic material, such as glitter.
- Use paper that is designed for use in laser printers. Do not use paper that is designed only for use in Inkjet printers.
- Use paper that is not too rough. Using smoother paper generally results in better print quality.

Step two: Check the environment

The environment can directly affect print quality and is a common cause for print-quality or paper-feeding issues. Try the following solutions:

- Move the printer away from drafty locations, such as open windows or doors, or air-conditioning vents.
- Make sure the printer is not exposed to temperatures or humidity outside of printer specifications.
- Do not place the printer in a confined space, such as a cabinet.
- Place the printer on a sturdy, level surface.
- Remove anything that is blocking the vents on the printer. The printer requires good air flow on all sides, including the top.
- Protect the printer from airborne debris, dust, steam, grease, or other elements that can leave residue inside the printer.

Step three: Set the individual tray alignment

Follow these steps when text or images are not centered or aligned correctly on the printed page when printing from specific trays.

1. From the Home screen on the printer control panel, navigate to the [Settings](#) application, and then select the [Settings](#) icon.
2. Select the following menus:
 - [Copy/Print](#) or [Print](#)
 - [Print Quality](#)
 - [Image Registration](#)

3. Select [Tray](#), and then select the tray to adjust.
4. Select [Print Test Page](#), and then follow the instructions on the printed pages.
5. Select [Print Test Page](#) again to verify the results, and then make further adjustments if necessary.
6. Select [Done](#) to save the new settings.

Try a different print driver

Try a different print driver when printing from a software program and the printed pages have unexpected lines in graphics, missing text, missing graphics, incorrect formatting, or substituted fonts.

Download any of the following drivers from the HP Web site: <http://www.hp.com/support/ljE50145>.

HP PCL.6 driver	If available, this printer-specific print driver supports older operating systems like Windows® XP and Windows Vista®. For a list of supported operating systems, go to www.hp.com/go/support .
HP PCL 6 driver	This printer-specific print driver supports Windows 7 and newer operating systems that support version 3 drivers. For a list of supported operating systems, go to www.hp.com/go/support .
HP PCL-6 driver	This printer-specific print driver supports Windows 8 and newer operating systems that support version 4 drivers. For a list of supported operating systems, go to www.hp.com/go/support .
HP UPD PS driver	<ul style="list-style-type: none"> • Recommended for printing with Adobe® software programs or with other highly graphics-intensive software programs • Provides support for printing from postscript emulation needs, or for postscript flash font support
HP UPD PCL 6	<ul style="list-style-type: none"> • Recommended for printing in all Windows environments • Provides the overall best speed, print quality, and printer feature support for most users • Developed to align with Windows Graphic Device Interface (GDI) for best speed in Windows environments • Might not be fully compatible with third-party and custom software programs that are based on PCL 5

Troubleshoot image defects

Review examples of image defects and steps to resolve these defects.

Table 6-1 Image defects table quick reference





Sample	Description	Possible solutions
Table 6-8 Light print on page 107	Table 6-6 Gray background or dark print on page 106	Table 6-4 Blank page — No print on page 104
		
Table 6-3 Black page on page 104	Table 6-2 Banding defects on page 103	Table 6-10 Streak defects on page 109
		
Table 6-5 Fixing/fuser defects on page 105	Table 6-7 Image placement defects on page 106	Table 6-9 Output defects on page 108
		

Image defects, no matter the cause, can often be resolved using the same steps. Use the following steps as a starting point for solving image defect issues.

1. Reprint the document. Print quality defects can be intermittent in nature or can go away completely with continued printing.
2. Check the condition of the cartridge or cartridges. If a cartridge is in a **Very Low** state (it has passed the rated life), replace the cartridge.
3. Make sure that the driver and tray print mode settings match the media that is loaded in the tray. Try using a different ream of media or a different tray. Try using a different print mode.
4. Make sure that the printer is within the supported operating temperature/humidity range.
5. Make sure that the paper type, size, and weight are supported by the printer. See the printer support page at support.hp.com for a list of the supported paper sizes and types for the printer.

 **NOTE:** The term “fusing” refers to the part of the printing process where toner is affixed to paper.

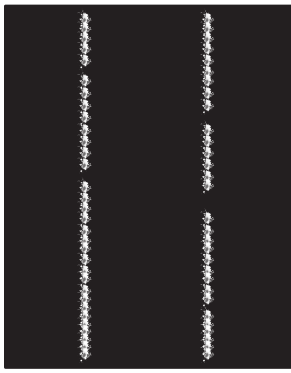
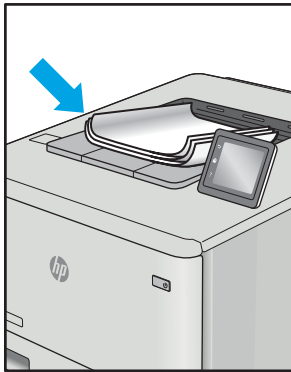
The following examples depict letter-size paper that has passed through the printer short-edge first.

Table 6-2 Banding defects

Sample	Description	Possible solutions
	<p>Dark or light lines which repeat down the length of the page, and are wide-pitch and/or impulse bands. They might be sharp or soft in nature. The defect displays only in areas of fill, not in text or sections with no printed content.</p>	<ol style="list-style-type: none"> 1. Reprint the document. 2. Try printing from another tray. 3. Replace the cartridge. 4. Use a different paper type. 5. Enterprise models only: From the Home screen on the printer control panel, go to the Adjust Paper Types menu, and then choose a print mode that is designed for a slightly heavier media than what you are using. This slows the print speed and might improve the print quality. 6. If the issue persists, go to support.hp.com.

Table 6-3 Black page

Sample	Description	Possible solutions
	The entire printed page is black.	<ol style="list-style-type: none">1. Visually inspect the cartridge to check for damage.2. Make sure that the cartridge is installed correctly.3. Replace the cartridge4. If the issue persists, go to support.hp.com.

Table 6-4 Blank page — No print

Sample	Description	Possible solutions
	The page is completely blank and contains no printed content.	<ol style="list-style-type: none">1. Make sure that the cartridges are genuine HP cartridges.2. Make sure that the cartridge is installed correctly.3. Print with a different cartridge.4. Check the paper type in the paper tray and adjust the printer settings to match. If necessary, select a lighter paper type.5. If the issue persists, go to support.hp.com.

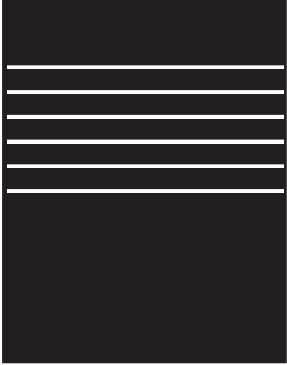
Table 6-5 Fixing/fuser defects

Sample	Description	Possible solutions
	<p>Slight shadows or offsets of the image are repeated down the page. The repeated image might fade with each recurrence.</p>	<ol style="list-style-type: none"> 1. Reprint the document. 2. Check the paper type in the paper tray and adjust the printer settings to match. If necessary, select a lighter paper type. 3. If the issue persists, go to support.hp.com.
	<p>Toner rubs off along either edge of the page. This defect is more common at the edges of high-coverage jobs, and on light media types, but can occur anywhere on the page.</p>	<ol style="list-style-type: none"> 1. Reprint the document. 2. Check the paper type in the paper tray and adjust the printer settings to match. If necessary, select a heavier paper type. 3. Enterprise models only: From the printer control panel, go to the Edge-to-Edge menu and then select Normal. Reprint the document. 4. Enterprise models only: From the printer control panel, select Auto Include Margins and then reprint the document. 5. If the issue persists, go to support.hp.com.

Table 6-6 Gray background or dark print

Sample	Description	Possible solutions
	<p>The image or text is darker than expected and/or the background is gray.</p>	<ol style="list-style-type: none"> 1. Make sure that the paper in the trays has not already been run through the printer. 2. Use a different paper type. 3. Reprint the document. 4. Mono models only: From the Home screen on the printer control panel, go to the Adjust Toner Density menu, and then adjust the toner density to a lower level. 5. Make sure that the printer is within the supported operating temperature and humidity range. 6. Replace the cartridge. 7. If the issue persists, go to support.hp.com.

Table 6-7 Image placement defects

Sample	Description	Possible solutions
	<p>The image is not centered, or is skewed on the page. The defect occurs when the paper is not positioned properly as it is pulled from the tray and moves through the paper path.</p>	<ol style="list-style-type: none"> 1. Reprint the document. 2. Remove the paper and then reload the tray. Make sure that all the paper edges are even on all sides. 3. Make sure that the top of the paper stack is below the tray-full indicator. Do not overfill the tray. 4. Make sure that the paper guides are adjusted to the correct size for the paper. Do not adjust the paper guides tightly against the paper stack. Adjust them to the indentations or markings in the tray. 5. If the issue persists, go to support.hp.com.

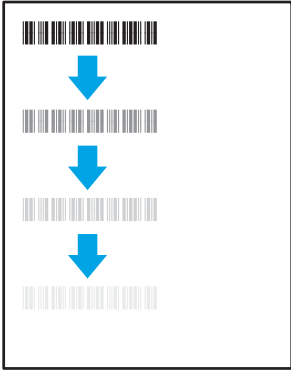
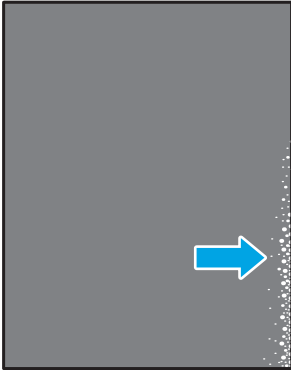
Table 6-8 Light print

Sample	Description	Possible solutions
	The printed content is light or faded on the entire page.	<ol style="list-style-type: none">1. Reprint the document.2. Remove the cartridge, and then shake it to redistribute the toner.3. Mono models only: Make sure that the EconoMode setting is disabled, both at the printer control panel and in the print driver.4. Make sure that the cartridge is installed correctly.5. Print a Supplies Status Page and check the life and usage of the cartridge.6. Replace the cartridge.7. If the issue persists, go to support.hp.com.

Table 6-9 Output defects



Sample	Description	Possible solutions
	<p>Printed pages have curled edges. The curled edge can be along the short or long side of the paper. Two types of curl are possible:</p> <ul style="list-style-type: none"> • Positive curl: The paper curls toward the printed side. The defect occurs in dry environments or when printing high-coverage pages. • Negative curl: The paper curls away from the printed side. The defect occurs in high-humidity environments or when printing low-coverage pages. 	<ol style="list-style-type: none"> 1. Reprint the document. 2. Positive curl: From the printer control panel, select a heavier paper type. The heavier paper type creates a higher temperature for printing. Negative curl: From the printer control panel, select a lighter paper type. The lighter paper type creates a lower temperature for printing. Try storing the paper in a dry environment prior to use, or use freshly-opened paper.
	<p>The paper does not stack well in the output tray. The stack might be uneven, skewed, or the pages might be pushed out of the tray and onto the floor. Any of the following conditions can cause this defect:</p> <ul style="list-style-type: none"> • Extreme paper curl • The paper in the tray is wrinkled or deformed • The paper is a non-standard paper type, such as envelopes • The output tray is too full 	<ol style="list-style-type: none"> 1. Reprint the document. 2. Extend the output bin extension. 3. If the defect is caused by extreme paper curl, refer to the troubleshooting steps for "Output curl." 4. Use a different paper type. 5. Use freshly-opened paper. 6. Remove the paper from the output tray before the tray gets too full. 7. If the issue persists, go to support.hp.com.

Table 6-10 Streak defects

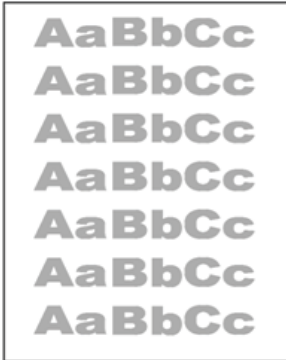
Sample	Description	Possible solutions
	<p>Light vertical streaks that usually span the length of the page. The defect displays only in areas of fill, not in text or sections with no printed content.</p>	<ol style="list-style-type: none"> 1. Reprint the document. 2. Remove the cartridge, and then shake it to redistribute the toner. 3. If the issue persists, go to support.hp.com. <p>NOTE: Both light and dark vertical streaks can occur when the printing environment is outside the specified range for temperature or humidity. Refer to your printer's environmental specifications for allowable temperature and humidity levels.</p>
	<p>Dark vertical lines which occur down the length of the page. The defect might occur anywhere on the page, in areas of fill or in sections with no printed content.</p>	<ol style="list-style-type: none"> 1. Reprint the document. 2. Remove the cartridge, and then shake it to redistribute the toner. 3. Print a cleaning page. 4. Check the toner level in the cartridge. 5. If the issue persists, go to support.hp.com.

Index

Symbols/Numerics

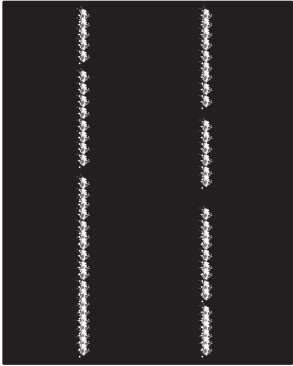
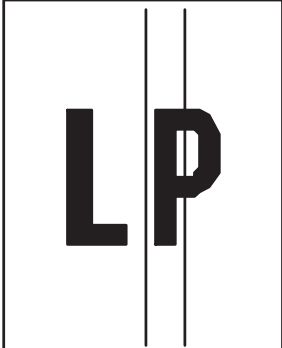
- 550-sheet paper trays
 - part numbers 26
- 550-sheet trays
 - jams 79

A

- accessories
 - ordering 26
 - overview 25
 - part numbers 26
- acoustic specifications 10, 13
- alternative letterhead mode 16, 18, 19, 22

B

- bin, output
 - locating 4
- Bonjour
 - identifying 52
- browser requirements
 - HP Embedded Web Server 52

C

- calibrate
 - colors 95
- cartridge
 - replacing 28
- cleaning
 - paper path 95, 96
- color options
 - changing, Windows 95
- color theme
 - changing, Windows 95
- colors
 - calibrate 95
- control panel
 - help 70
 - locating 4

- locating features 4
- locating features on the touchscreen control panel 7
- copy settings
 - HP Embedded Web Server 52, 54
- customer support
 - online 69

D

- default gateway, setting 60
- deleting
 - stored jobs 41, 44
- digital send settings
 - HP Embedded Web Server 52, 54
- dimensions, printer 10, 13
- document feeder
 - paper-feeding problems 73
- double-sided printing
 - Mac 38
 - Windows 34
- drivers, supported 10
- duplex printing
 - Mac 38
- duplex printing (double-sided)
 - settings (Windows) 34
 - Windows 34
- duplexing
 - manually (Mac) 38
 - manually (Windows) 34

E

- easy-access USB printing 45
- EconoMode setting 95, 96
- electrical specifications 10, 13
- Embedded Web Server
 - changing network settings 60
 - changing printer name 60
 - opening 60

- Embedded Web Server (EWS)
 - assigning passwords 63, 64
 - features 52
 - network connection 52
- energy use, optimizing 66
- envelopes
 - orientation 16, 17
- envelopes, loading 23
- Ethernet (RJ-45)
 - locating 4, 5
- Explorer, versions supported
 - HP Embedded Web Server 52

F

- fax settings
 - HP Embedded Web Server 52, 54
- formatter
 - locating 4, 5
- fuser
 - jams 79

G

- gateway, setting default 60
- general configuration
 - HP Embedded Web Server 52, 54

H

- hard disks
 - encrypted 63, 65
- hard drive
 - part number 26
- Help button
 - locating 4, 7
- help, control panel 70
- Hi-Speed USB 2.0 printing port
 - locating 4, 5
- Home button
 - locating 4, 7

- HP Customer Care 69
 - HP Embedded Web Server
 - changing network settings 60
 - changing printer name 60
 - copy settings 52, 54
 - digital send settings 52, 54
 - fax settings 52, 54
 - general configuration 52, 54
 - HP Web Services 52, 54, 57
 - information pages 52, 54
 - network settings 52, 54, 57
 - opening 60
 - other links list 52, 54, 59
 - print settings 52, 54, 55
 - scan settings 52, 54
 - security settings 52, 54, 56
 - supplies 56
 - troubleshooting tools 52, 54, 56
 - HP Embedded Web Server (EWS)
 - features 52
 - network connection 52
 - HP Web Jetadmin 68
 - HP Web Services
 - enabling 52, 54, 57
- I**
- image quality
 - check toner-cartridge status 95, 96, 98
 - Information button
 - locating 7
 - information pages
 - HP Embedded Web Server 52, 54
 - interface ports
 - locating 4, 5
 - Internet Explorer, versions supported
 - HP Embedded Web Server 52
 - IP Security 63, 65
 - IPsec 63, 65
 - IPv4 address 60
 - IPv6 address 60
- J**
- jams
 - 2,000-sheet high-capacity input tray 79
 - 550-sheet trays 79
 - auto-navigation 79, 80
 - causes of 79, 80
 - fuser 79
 - locations 79
 - output bin 79
 - rear door 79
 - Tray 1 79
 - Tray 2 79
 - Jetadmin, HP Web 68
 - jobs, stored
 - creating (Windows) 41
 - deleting 41, 44
 - Mac settings 41
 - printing 41
- K**
- keypad
 - locating 4
- L**
- label
 - orientation 24
 - labels
 - printing (Windows) 34
 - printing on 24
 - labels, loading 24
 - LAN port
 - locating 4, 5
 - loading
 - paper in Tray 1 16
 - paper in Tray 2 and the 550-sheet trays 19
 - local area network (LAN)
 - locating 4, 5
 - lock
 - formatter 63, 65
 - lock, cable slot on formatter
 - locating 5
- M**
- Mac driver settings
 - Job Storage 41
 - manage the printer
 - overview 51
 - managing network 60
 - manual duplex
 - Mac 38
 - Windows 34
 - memory
 - included 10
 - memory chip (toner)
 - locating 28
 - mobile printing, software supported 10
 - multiple pages per sheet
 - printing (Mac) 38
 - printing (Windows) 34
- N**
- Netscape Navigator, versions supported
 - HP Embedded Web Server 52
 - network
 - printer name, changing 60
 - settings, changing 60
 - settings, viewing 60
 - network duplex settings, changing 60
 - network link speed settings, changing 60
 - network settings
 - HP Embedded Web Server 52, 54, 57
 - networks
 - default gateway 60
 - HP Web Jetadmin 68
 - IPv4 address 60
 - IPv6 address 60
 - subnet mask 60
 - supported 10
 - NFC accessory
 - part number 26
- O**
- on/off button
 - locating 4
 - online help, control panel 70
 - online support 69
 - operating systems, supported 10, 11
 - ordering
 - supplies and accessories 26
 - other links list
 - HP Embedded Web Server 52, 54, 59
 - output bin
 - clear jams 79
 - locating 4
- P**
- pages per minute 10
 - pages per sheet
 - selecting (Mac) 38
 - selecting (Windows) 34

- paper
 - jams 79, 80
 - loading Tray 1 16
 - loading Tray 2 and the 550-sheet trays 19
 - selecting 95, 96, 100
 - Tray 1 orientation 16, 17
 - Tray 2 and the 550-sheet trays orientation 19, 21
 - paper jams
 - 550-sheet trays 79
 - fuser 79
 - locations 79
 - output bin 79
 - rear door 79
 - Tray 1 79
 - Tray 2 79
 - paper pickup problems
 - solving 73, 75
 - paper trays
 - overview 15
 - part numbers 26
 - paper type
 - selecting (Windows) 34
 - paper types
 - selecting (Mac) 38
 - paper, ordering 26
 - part numbers
 - accessories 26
 - replacement parts 26
 - supplies 26
 - toner cartridges 26
 - parts
 - overview 25
 - ports
 - locating 4, 5
 - potential shock hazard 3
 - power
 - consumption 10, 13
 - power connection
 - locating 4, 5
 - power switch
 - locating 4
 - power usage
 - 1 watts or less 66
 - print
 - overview 33
 - print drivers, supported 10
 - print media
 - loading in Tray 1 16
 - print on both sides
 - Mac 38
 - manually, Windows 34
 - Windows 34
 - print settings
 - HP Embedded Web Server 52, 54, 55
 - printer
 - overview 1
 - printing
 - from USB storage accessories 45
 - stored jobs 41
 - printing on both sides
 - settings (Windows) 34
 - private printing 41
 - product number
 - locating 4, 5
- R**
- rear door
 - jams 79
 - locating 5
 - replacement parts
 - part numbers 26
 - replacing
 - toner cartridge 28
 - reset factory settings 71
 - RJ-45 port
 - locating 4, 5
- S**
- scan settings
 - HP Embedded Web Server 52, 54
 - security settings
 - HP Embedded Web Server 52, 54, 56
 - security
 - encrypted hard disk 63, 65
 - included 10
 - serial number
 - locating 4, 5
 - settings
 - reset to factory (default) settings 71
 - Sign In button
 - locating 4, 7
 - Sign Out button
 - locating 4, 7
 - sleep delay
 - setting 66
 - solve problems
 - overview 69
 - special paper
 - printing (Windows) 34
 - specifications
 - electrical and acoustic 10, 13
 - speed, optimizing 66
 - stand
 - part number 26
 - storage, job
 - Mac settings 41
 - store print jobs 41
 - stored jobs
 - creating (Mac) 41
 - creating (Windows) 41
 - deleting 41, 44
 - printing 41
 - storing jobs
 - with Windows 41
 - subnet mask 60
 - supplies
 - HP Embedded Web Server 56
 - low threshold settings 72
 - ordering 26
 - overview 25
 - part numbers 26
 - replacing toner cartridge 28
 - using when low 72
 - support
 - online 69
 - supported operating systems 11
 - system requirements
 - HP Embedded Web Server 52
 - minimum 10
- T**
- TCP/IP
 - manually configuring IPv4 parameters 60
 - manually configuring IPv6 parameters 60
 - technical specifications 10
 - technical support
 - online 69
 - toner cartridge
 - components 28
 - low threshold settings 72
 - replacing 28
 - using when low 72

- toner cartridges
 - part numbers 26
- touchscreen
 - locating features 4, 7
- transparencies
 - printing (Windows) 34
- Tray 1
 - jams 79
 - loading envelopes 23
 - paper orientation 16, 17
- Tray 2
 - jams 79
- Tray 2 and the 550-sheet trays
 - loading 19
 - paper orientation 19, 21
- trays
 - capacity 10
 - included 10
 - locating 4
 - use alternative letterhead mode 18, 22
- troubleshooting
 - check toner-cartridge status 95, 96, 98
 - jams 79, 80
 - paper feed problems 73
- troubleshooting tools
 - HP Embedded Web Server 52, 54, 56
- two-sided printing
 - settings (Windows) 34

U

- USB port
 - enabling 45, 46, 48, 49
 - locating 4, 5
- USB ports, optional
 - part number 26
- USB storage accessories
 - printing from 45

W

- web browser requirements
 - HP Embedded Web Server 52
- websites
 - customer support 69
 - HP Web Jetadmin, downloading 68
- weight, printer 10, 13
- Wi-Fi Direct Print 10