

# CRS451V and CRS456V

Submersible Water-Level  
Recording Sensors





# Guarantee

---

This equipment is guaranteed against defects in materials and workmanship. We will repair or replace products which prove to be defective during the guarantee period as detailed on your invoice, provided they are returned to us prepaid. The guarantee will not apply to:

- Equipment which has been modified or altered in any way without the written permission of Campbell Scientific
- Batteries
- Any product which has been subjected to misuse, neglect, acts of God or damage in transit.

Campbell Scientific will return guaranteed equipment by surface carrier prepaid. Campbell Scientific will not reimburse the claimant for costs incurred in removing and/or reinstalling equipment. This guarantee and the Company's obligation thereunder is in lieu of all other guarantees, expressed or implied, including those of suitability and fitness for a particular purpose. Campbell Scientific is not liable for consequential damage.

Please inform us before returning equipment and obtain a Repair Reference Number whether the repair is under guarantee or not. Please state the faults as clearly as possible, and if the product is out of the guarantee period it should be accompanied by a purchase order. Quotations for repairs can be given on request. It is the policy of Campbell Scientific to protect the health of its employees and provide a safe working environment, in support of this policy a "Declaration of Hazardous Material and Decontamination" form will be issued for completion.

When returning equipment, the Repair Reference Number must be clearly marked on the outside of the package. Complete the "Declaration of Hazardous Material and Decontamination" form and ensure a completed copy is returned with your goods. Please note your Repair may not be processed if you do not include a copy of this form and Campbell Scientific Ltd reserves the right to return goods at the customers' expense.

Note that goods sent air freight are subject to Customs clearance fees which Campbell Scientific will charge to customers. In many cases, these charges are greater than the cost of the repair.



Campbell Scientific Ltd,  
80 Hathern Road,  
Shepshed, Loughborough, LE12 9GX, UK  
Tel: +44 (0) 1509 601141  
Fax: +44 (0) 1509 270924  
Email: [support@campbellsci.co.uk](mailto:support@campbellsci.co.uk)  
[www.campbellsci.co.uk](http://www.campbellsci.co.uk)



# PLEASE READ FIRST

---

## About this manual

Please note that this manual was originally produced by Campbell Scientific Inc. primarily for the North American market. Some spellings, weights and measures may reflect this origin.

Some useful conversion factors:

<b>Area:</b> 1 in <sup>2</sup> (square inch) = 645 mm <sup>2</sup>	<b>Mass:</b> 1 oz. (ounce) = 28.35 g 1 lb (pound weight) = 0.454 kg
<b>Length:</b> 1 in. (inch) = 25.4 mm 1 ft (foot) = 304.8 mm 1 yard = 0.914 m 1 mile = 1.609 km	<b>Pressure:</b> 1 psi (lb/in <sup>2</sup> ) = 68.95 mb
	<b>Volume:</b> 1 UK pint = 568.3 ml 1 UK gallon = 4.546 litres 1 US gallon = 3.785 litres

In addition, while most of the information in the manual is correct for all countries, certain information is specific to the North American market and so may not be applicable to European users.

Differences include the U.S standard external power supply details where some information (for example the AC transformer input voltage) will not be applicable for British/European use. *Please note, however, that when a power supply adapter is ordered it will be suitable for use in your country.*

Reference to some radio transmitters, digital cell phones and aerials may also not be applicable according to your locality.

Some brackets, shields and enclosure options, including wiring, are not sold as standard items in the European market; in some cases alternatives are offered. Details of the alternatives will be covered in separate manuals.

Part numbers prefixed with a “#” symbol are special order parts for use with non-EU variants or for special installations. Please quote the full part number with the # when ordering.

## Recycling information



At the end of this product's life it should not be put in commercial or domestic refuse but sent for recycling. Any batteries contained within the product or used during the products life should be removed from the product and also be sent to an appropriate recycling facility.

Campbell Scientific Ltd can advise on the recycling of the equipment and in some cases arrange collection and the correct disposal of it, although charges may apply for some items or territories.

For further advice or support, please contact Campbell Scientific Ltd, or your local agent.



Campbell Scientific Ltd, 80 Hathern Road, Shepshed, Loughborough, LE12 9GX,  
UK Tel: +44 (0) 1509 601141 Fax: +44 (0) 1509 270924  
Email: [support@campbellsci.co.uk](mailto:support@campbellsci.co.uk)  
[www.campbellsci.co.uk](http://www.campbellsci.co.uk)



# Safety

---

**DANGER** — MANY HAZARDS ARE ASSOCIATED WITH INSTALLING, USING, MAINTAINING, AND WORKING ON OR AROUND **TRIPODS, TOWERS, AND ANY ATTACHMENTS TO TRIPODS AND TOWERS SUCH AS SENSORS, CROSSARMS, ENCLOSURES, ANTENNAS, ETC.** FAILURE TO PROPERLY AND COMPLETELY ASSEMBLE, INSTALL, OPERATE, USE, AND MAINTAIN TRIPODS, TOWERS, AND ATTACHMENTS, AND FAILURE TO HEED WARNINGS, INCREASES THE RISK OF DEATH, ACCIDENT, SERIOUS INJURY, PROPERTY DAMAGE, AND PRODUCT FAILURE. TAKE ALL REASONABLE PRECAUTIONS TO AVOID THESE HAZARDS. CHECK WITH YOUR ORGANIZATION'S SAFETY COORDINATOR (OR POLICY) FOR PROCEDURES AND REQUIRED PROTECTIVE EQUIPMENT PRIOR TO PERFORMING ANY WORK.

Use tripods, towers, and attachments to tripods and towers only for purposes for which they are designed. Do not exceed design limits. Be familiar and comply with all instructions provided in product manuals. Manuals are available at [www.campbellsci.eu](http://www.campbellsci.eu) or by telephoning +44(0) 1509 828 888 (UK). You are responsible for conformance with governing codes and regulations, including safety regulations, and the integrity and location of structures or land to which towers, tripods, and any attachments are attached. Installation sites should be evaluated and approved by a qualified engineer. If questions or concerns arise regarding installation, use, or maintenance of tripods, towers, attachments, or electrical connections, consult with a licensed and qualified engineer or electrician.

## General

- Prior to performing site or installation work, obtain required approvals and permits. Comply with all governing structure-height regulations, such as those of the FAA in the USA.
- Use only qualified personnel for installation, use, and maintenance of tripods and towers, and any attachments to tripods and towers. The use of licensed and qualified contractors is highly recommended.
- Read all applicable instructions carefully and understand procedures thoroughly before beginning work.
- Wear a **hardhat** and **eye protection**, and take **other appropriate safety precautions** while working on or around tripods and towers.
- **Do not climb** tripods or towers at any time, and prohibit climbing by other persons. Take reasonable precautions to secure tripod and tower sites from trespassers.
- Use only manufacturer recommended parts, materials, and tools.

## Utility and Electrical

- **You can be killed** or sustain serious bodily injury if the tripod, tower, or attachments you are installing, constructing, using, or maintaining, or a tool, stake, or anchor, come in **contact with overhead or underground utility lines**.
- Maintain a distance of at least one-and-one-half times structure height, or 20 feet, or the distance required by applicable law, **whichever is greater**, between overhead utility lines and the structure (tripod, tower, attachments, or tools).
- Prior to performing site or installation work, inform all utility companies and have all underground utilities marked.
- Comply with all electrical codes. Electrical equipment and related grounding devices should be installed by a licensed and qualified electrician.

## Elevated Work and Weather

- Exercise extreme caution when performing elevated work.
- Use appropriate equipment and safety practices.
- During installation and maintenance, keep tower and tripod sites clear of un-trained or non-essential personnel. Take precautions to prevent elevated tools and objects from dropping.
- Do not perform any work in inclement weather, including wind, rain, snow, lightning, etc.

## Maintenance

- Periodically (at least yearly) check for wear and damage, including corrosion, stress cracks, frayed cables, loose cable clamps, cable tightness, etc. and take necessary corrective actions.
- Periodically (at least yearly) check electrical ground connections.

WHILE EVERY ATTEMPT IS MADE TO EMBODY THE HIGHEST DEGREE OF SAFETY IN ALL CAMPBELL SCIENTIFIC PRODUCTS, THE CUSTOMER ASSUMES ALL RISK FROM ANY INJURY RESULTING FROM IMPROPER INSTALLATION, USE, OR MAINTENANCE OF TRIPODS, TOWERS, OR ATTACHMENTS TO TRIPODS AND TOWERS SUCH AS SENSORS, CROSSARMS, ENCLOSURES, ANTENNAS, ETC.



# Table of contents

---

<b>1. Introduction</b> .....	<b>1</b>
<b>2. Precautions</b> .....	<b>1</b>
<b>3. Initial inspection</b> .....	<b>2</b>
3.1 Ships with .....	2
<b>4. Overview</b> .....	<b>2</b>
<b>5. Specifications</b> .....	<b>3</b>
<b>6. Installation</b> .....	<b>5</b>
6.1 Appropriate depth .....	5
6.2 Avoiding freezing conditions .....	6
6.3 Dislodge bubbles .....	6
6.4 Well installation .....	6
6.5 Other installations .....	7
6.6 Battery voltage reading .....	7
6.7 Memory .....	7
6.8 Heyco cable grip .....	7
<b>7. Programming</b> .....	<b>8</b>
7.1 Computer connection using the A200 .....	9
7.1.1 Driver installation .....	9
7.1.2 A200 wiring .....	9
7.1.3 Powering the sensor .....	10
7.1.4 Determining which COM port the A200 has been assigned .....	10
7.2 Settings .....	11
7.3 Connect to the CRS451V/CRS456V .....	11
7.4 Configure CRS45X for measurements .....	12
<b>8. Maintenance</b> .....	<b>17</b>
8.1 Every visit .....	17
8.2 Every two to three years or on a rotating schedule .....	17
8.3 Battery replacement .....	18
<b>9. Troubleshooting</b> .....	<b>24</b>

<b>Appendix A. Calibration certificate</b> .....	<b>26</b>
<b>Appendix B. Conversion to units of measurement</b> .....	<b>27</b>

# 1. Introduction

---

The CRS451V/CRS456V is a water-level and water-temperature sensor with a clock and memory to store the data, in a compact stainless-steel case. This frees users to place the sensor in remote sites and let it store data for long periods of time. The CRS451V/CRS456V supports standard time-based scanning and recording along with event-based recording based on water level change (Delta) or logarithmic time sequence for pump and slug tests. HydroSci software, available at [www.campbellsci.eu/downloads/hydrosci](http://www.campbellsci.eu/downloads/hydrosci), supports test set up, data retrieval, and data display.

The CRS451V has a 316L stainless-steel case that can be submerged in most canals, wells, ponds, lakes, and streams. The CRS456V has a rugged titanium case that allows it to be used in saltwater or other harsh environments.

## 2. Precautions

---

- Although the CRS451V/CRS456V is a rugged and reliable device, it is also a highly precise scientific instrument and should be handled as such.
- The CRS451V/CRS456V will be damaged if encased in frozen liquid (see [Avoiding freezing conditions](#) (p. 6) for more information).
- Dropping the instrument or allowing it to “free fall” down a well may damage the transducer.
- Confirm the compatibility of the instrument to non-water environments before installation.
- The CRS456V should be used in harsh water applications, including salt water.
- One of the most common modes of sensor failure is caused by the introduction of water into the vent tube. To prevent water from accumulating in the vent tube, it is necessary to terminate the cable in a dry environment. It is critical to exchange the desiccant when needed to keep the vent tube dry.

# 3. Initial inspection

---

- Upon receipt of the CRS451V/CRS456V, inspect the packaging for any signs of shipping damage. File damage claims with the shipping company.
- Immediately check package contents against the shipping documentation (see [Ships with](#) (p. 2). Contact Campbell Scientific with any discrepancies.
- The model number and pressure range are etched on the housing. Check this information against the shipping documentation to ensure that the expected product was received.

## 3.1 Ships with

- NIST Traceable Calibration Certificate

# 4. Overview

---

The CRS451V/CRS456V, Submersible Water-Level Recording Sensor, provides reliable, accurate pressure/level measurements that are fully temperature compensated. The vented cable allows the sensor to remain in place when data is being retrieved; precludes the need for a separate barometric sensor to compensate for changes in atmospheric pressure; and provides you with the ability to attach the sensor directly to a cell phone or radio for remote data collection using LoggerNet.

The 24 bit A/D has simultaneous 50/60 Hz rejection and automatic calibration for each measurement. A number of additional advanced measurement techniques are employed to harness the best possible performance available from today's state of the art pressure sensor technology. The CRS451V/CRS456V reverts to a low power sleep state between measurements. A series of measurements are performed yielding a temperature and pressure value. This measurement cycle can be as fast as 1 second.

The design features a piezoresistive sensor housed in a 316L stainless steel (CRS451V) or titanium (CRS456V) package to enhance reliability. The rugged construction makes the CRS451V/CRS456V suitable for water level measurement in irrigation applications, water wells, lakes, streams, and tanks. The titanium package of the CRS456V makes it ideal for salt water or other harsh environments.

The CRS451V/CRS456V has three nose cone options. The weighted nose cone makes the transducer easier to submerge to depth. The NPT option allows the sensor to be mounted to a 1/4 inch fitting. The nose cones can be exchanged at a later time.

Communicating with the CRS451V/CRS456V requires a micro USB cable and HydroSci software running on a computer with Windows XP or later. Configurable settings can be changed using Campbell Scientific's HydroSci software utility.

## 5. Specifications

---

Features:

- Field replaceable batteries
- Campbell Scientific quality
- No additional data logger, enclosure, and power supply; reduces system costs and simplifies installation
- Free customer-friendly software for communication, configuration, data collection
- Fast scan rate
- Large data storage capacity
- High accuracy
- Long battery life
- Can be wired directly to a radio or cell phone for remote data collection (in which case an enclosure and separate power supply are required)

<b>Measurement time:</b>	< 1 s typical
<b>Output:</b>	RS-232
<b>Internal data collection memory:</b>	4 MB
<b>HydroSci supported operating systems:</b>	Windows XP, Windows Vista, or Windows 7
<b>Logging/scanning modes:</b>	Standard, Delta, Logarithmic
<b>Power requirements:</b>	Internal user-replaceable lithium battery
<b>Battery life:</b>	5+ years when logging interval is once per hour
<b>Power consumption</b>	
<b>Quiescent current:</b>	< 80 $\mu$ A
<b>Measurement/communication current:</b>	4 mA for 1 s measurement

Distance from pressure sensor interface  
(black line etched on housing) to:

End of NPT fitting:	2.54 cm (1 in)
End of standard nose cone:	2.3 cm (0.9 in)
End of weighted nose cone:	9.9 cm (3.9 in)

Measurement ranges<sup>1</sup>:

Pressure (psig)	Pressure (kPa)	Metres of fresh water	Feet of fresh water
0 to 7.25	0 to 50	0 to 5.1	0 to 16.7
0 to 14.5	0 to 100	0 to 10.2	0 to 33.4
0 to 29	0 to 200	0 to 20.4	0 to 67
0 to 72.5	0 to 500	0 to 50.9	0 to 167
0 to 145	0 to 1000	0 to 102	0 to 334.5

Accuracy

Pressure reading <sup>2</sup> :	0.1% full-scale range TEB <sup>3</sup>
Temperature:	±0.2 °C
Resolution:	0.0035% full-scale range
Overpressure:	2x pressure range
Dry storage temperature:	-30 to 80 °C
Operating temperature:	0 to 60 °C

**CAUTION:**

Freezing conditions may damage the CRS451/CRS456 (see [Avoiding freezing conditions](#) (p. 6) for more information).

Body Material

CRS451:	316L Stainless Steel
CRS456:	Titanium

Element Material

CRS451:	316L Stainless Steel
CRS456:	Hastelloy®

Standard Cone Material: Delrin®

<b>Weighted and NPT Material:</b>	Stainless Steel
<b>Dimensions</b>	
<b>Length:</b>	22.23 cm (8.75 in)
<b>Diameter:</b>	2.22 cm (0.875 in)
<b>Weight:</b>	230 g (0.51 lb)

<sup>1</sup>The CRS451 is a sealed gauge sensor and when not submerged will read approximately 1 bar at sea level and less as elevation increases. The CRS451 is calibrated at nine pressures starting at 0.6 bar up to full scale referenced to 1 bar. Points below 1 bar are used in the calibration for the benefit of those who deploy this sensor at elevations above sea level.

<sup>2</sup>The accuracy specification listed pertains to the level of accuracy that the CRS451/CRS456 is able to measure pressure. If a barometric pressure sensor is used to remove the component of atmospheric pressure from the pressure reading provided by the CRS451/CRS456 while submerged in a column of water vented to the atmosphere, the error of the barometric sensor must be considered when calculating the resulting accuracy of the water level reading.

<sup>3</sup>Total Error Band (TEB) includes the combined errors due to nonlinearity, hysteresis, nonrepeatability, and thermal effects over the compensated temperature range, per ISA S51.1.

## 6. Installation

---

The CRS451V/CRS456V is designed for water level measurements. Typical applications include agricultural water level/flow, water wells, lakes, streams, and tanks. If the device is to be installed in a liquid other than water or in contaminated water, check the compatibility of the wetted material. The CRS456V should be used in harsh water applications, including salt water.

### 6.1 Appropriate depth

The CRS451V/CRS456V must be installed below the water at a fixed depth. This depth should be chosen so that the water pressure will never exceed the transducer's pressure range (twice its pressure rating).

**CAUTION:**

The output reading will not be correct, and the transducer can be damaged if pressure is twice its pressure rating.

Pressure can be converted to feet of fresh water using the following simple equation:

$$1 \text{ psi} = 2.31 \text{ feet of water}$$

For example, the maximum depth with a pressure range of 0 to 7.25 psig is 16.748 feet of water. See [Table B-1](#) (p. 27) for other units.

## 6.2 Avoiding freezing conditions

Expansion of water due to freezing will irreparably damage the CRS451V/CRS456V. The CRS451V/CRS456V can be safely deployed in freezing conditions if the sensor is placed below the frost line. In a lake or channel of moving water, often the sensor can be placed deep enough to avoid freezing. In shallow conditions, where the water body is at risk of freezing solid, placing the sensor in a stilling well that extends below the frost line will protect the sensor from freezing water.

## 6.3 Dislodge bubbles

While submersing the CRS451V/CRS456V, air bubbles may become trapped inside the nose cone, causing small, offset errors until the bubbles dissolve. Dislodge these bubbles by gently shaking the CRS451V/CRS456V while under water.

### CAUTION:

Hitting the instrument against the well casing or other solid surface could damage the CRS451V/CRS456V.

### CAUTION:

If the bubbles are not removed by rotation and shaking underwater (or bleeding out the air in a closed system), the CRS451V/CRS456V reading will drift lower by the distance of the gap as the air is slowly dissolved into the water over time.

## 6.4 Well installation

Campbell Scientific offers a braided stainless steel cable to lower the instrument to an appropriate depth and to suspend the CRS451V/CRS456V in a well.

With long drops, it may be necessary to use the weighted nose cone (option –WN).

For surface installations, the instrument body can be strapped with tie wraps or tape. Campbell Scientific offers cable ties to secure the cable. If installing in a well, fasten the cable to the well head.

## 6.5 Other installations

The CRS451V/CRS456V can be installed in any position; however, when it leaves the factory it is tested in the vertical position. There will be an offset error if not installed vertically; contact Campbell Scientific for more information. Strapping the transducer body with tie wraps or tape will not hurt it.

## 6.6 Battery voltage reading

The voltage of the lithium ion battery used in the CRS451V/CRS456V will abruptly decrease at the end of the battery's useful life, which makes predicting remaining battery life difficult by measuring battery voltage alone. Knowing the energy consumption of the CRS451V/CRS456V while in operation, HydroSci displays a predicted remaining battery life by combining an estimate of the energy consumed based on the totalized measurements since new and direct battery measurements. For this reason, if the battery is removed from the CRS451V/CRS456V anytime during deployment and then replaced, HydroSci will assume a fresh battery was added to the device and the estimated remaining battery life will be overstated.

For similar reasons, if the operating system is upgraded or sent to the CRS451V/CRS456V, the estimated remaining battery life will also be exaggerated by HydroSci.

## 6.7 Memory

The internal data memory stores 4,000,000 bytes of data. Each table record uses 4 bytes for a time stamp and 4 bytes for each data value. For example, a table with two data values, such as pressure and temperature, will use 12 bytes per record. If a record is written every 30 seconds, the number of records that occur each day is:

$$\text{Records per day} = 86,400 \text{ s} / 30 \text{ s} = 2880 \text{ records}$$

Therefore, the memory used in one day is:

$$\text{Bytes per day} = 2880 \times 12 \text{ bytes} = 34,560$$

Therefore, the memory will last:

$$\text{Number of days} = 4,000,000 \text{ bytes} / (34,560 \text{ bytes/day}) = 115 \text{ days}$$

## 6.8 Heyco cable grip

To protect your transducer during deployment, Campbell Scientific offers the Heyco cable grip (FIGURE 6-1 (p. 8)) to clamp the transducer to the submerged end of a 1-inch PVC pipe (FIGURE 6-2 (p. 8)). The PVC pipe will help protect the sensor and cable from debris and disturbances

while also providing a more secure means of anchoring the sensor to minimize movement. The Heyco fitting is not meant to be water tight and water will likely fill the submerged pipe behind the fitting. A 1-inch female adapter socket with FPT threads is needed between the Heyco cable grip and 1-inch PVC pipe. This adapter socket is available at any store that sells PVC pipe.

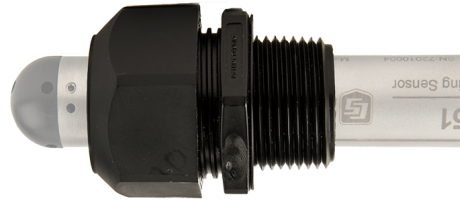

*FIGURE 6-1. Heyco Cable Grip*

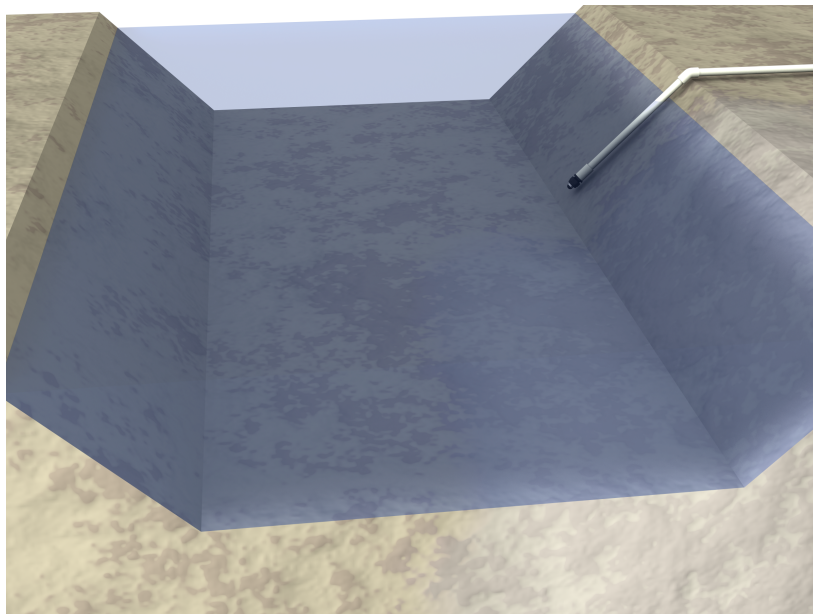

*FIGURE 6-2. Transducer mounted in PVC pipe using the 31648 Heyco cable grip*

## 7. Programming

---

Communicating with the CRS451V/CRS456V requires a micro USB cable and HydroSci software running on a computer with Windows XP or later.

The CRS451V/CRS456V is configured using the HydroSci software, which is downloaded from [www.campbellsci.eu/downloads/hydrosci](http://www.campbellsci.eu/downloads/hydrosci).

Communicating with the CRS451V/CRS456V through a USB port requires Campbell Scientific A200 Sensor to PC Interface. The A200 USB driver should be installed automatically when you plug the port into your computer, provided there is a working Internet connection. If not, the driver can be installed from [www.campbellsci.eu/a200-support](http://www.campbellsci.eu/a200-support). Communicating through a serial port requires a standard serial cable and a female DB9 terminal block.

**CAUTION:**

If you are using an XP computer, please have the driver disk in the CD/DVD drive before plugging in the USB cord. A driver will need to be installed before the computer can connect with the sensor.

## 7.1 Computer connection using the A200

The A200 or another device is required to connect the CRS451V/CRS456V to a computer. This allows sensor settings to be changed using the Device Configuration Utility.

### 7.1.1 Driver installation

If the A200 has not been previously plugged into your computer, the A200 driver needs to be loaded onto your computer.

**NOTE:**

Drivers should be loaded before plugging the A200 into the computer.

The A200 drivers can be downloaded, at no charge, from: [www.campbellsci.eu/downloads](http://www.campbellsci.eu/downloads).

### 7.1.2 A200 wiring

One end of the A200 has a terminal block while the other end has a type B female USB port. The terminal block provides **12V**, **G**, **Tx**, and **Rx** terminals for connecting the sensor (see [FIGURE 7-1](#) (p. 10) and [Table 7-1](#) (p. 10)). The data cable shipped with the A200 has a USB type-A male connector that attaches to a computer USB port, and a type B male connector that attaches to the A200 USB port.



FIGURE 7-1. A200 Sensor-to-Computer Interface

Colour	Sensor cable label	A200 terminal
Red	12V	+12Vdc
Black	G	G
White	C	Tx
Blue	G	Rx
Yellow	G	G
Clear	Signal ground	G

### 7.1.3 Powering the sensor

The A200 provides power to the sensor when it is connected to a computer USB port. An internal DC/DC converter boosts the 5 VDC supply from the USB connection to a 12 VDC output is required to power the sensor.

### 7.1.4 Determining which COM port the A200 has been assigned

When the A200 driver is loaded, the A200 is assigned a COM port number. This COM port number is needed when using the Device Configuration Utility.

Often, the assigned COM port will be the next port number that is free. However, if other devices have been installed in the past (some of which may no longer be plugged in), the A200 may be assigned a higher COM port number.

To check which COM port has been assigned to the A200, watch for the appearance of a new COM port in the list of COM ports offered in the software package (e.g., LoggerNet) before and after the installation, or look in the Windows Device Manager list under the ports section (access via the control panel).

## 7.2 Settings

Before connecting to the CRS451V/CRS456V, you can change the sensor name or the appearance of HydroSci screens by clicking on **Settings** at the upper right portion of the HydroSci screen.

Selecting **LoggerNet Communication Settings** will allow the user to change the PakBus address and baud rate at which the sensor communicates. If these settings are changed, be sure to make identical changes to the station settings in LoggerNet or future communications may fail.

## 7.3 Connect to the CRS451V/CRS456V

1. Select **CRS45X** from the left margin.
2. Select appropriate **COM Port**.
3. If you have not made a USB connection to your computer, click on the **Show Connect Instructions and Device Installation** drop-down arrow.

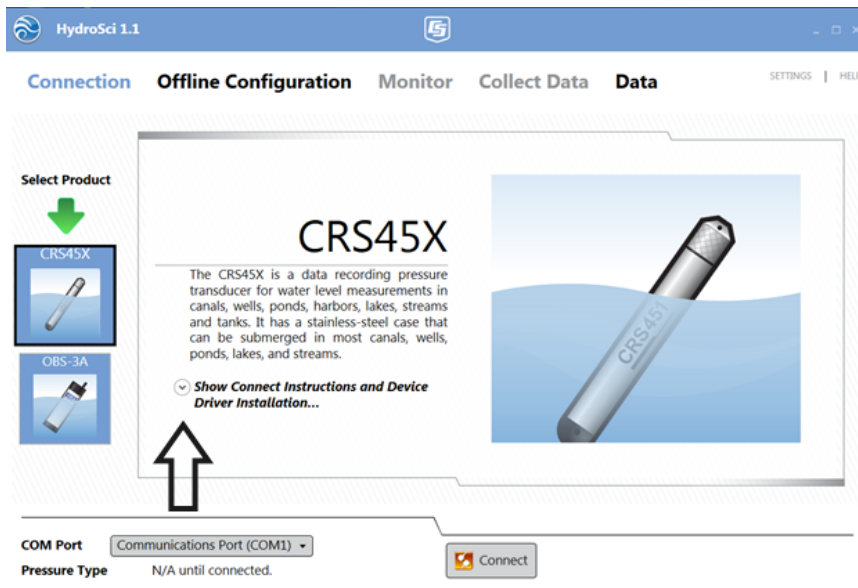

4. After clicking the drop-down arrow, you get the following instructions:

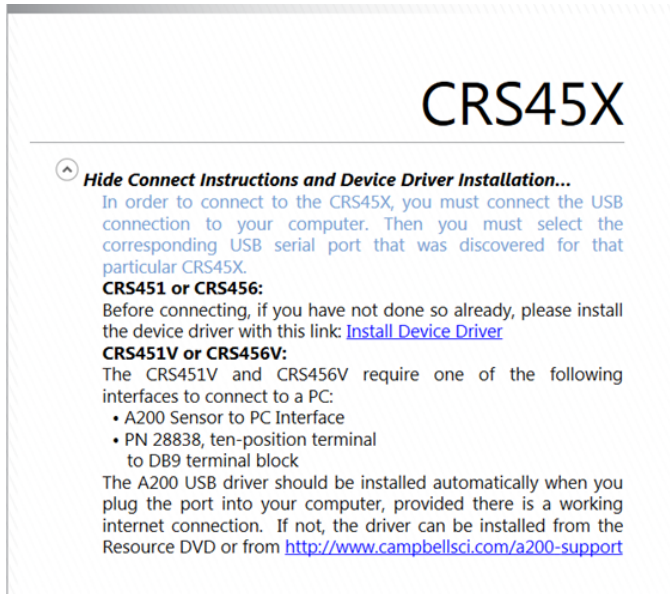

The screenshot shows a window titled "CRS45X" with a "Hide Connect Instructions and Device Driver Installation..." button. The text below provides instructions for connecting the device to a computer via USB, including details about the A200 USB driver and the need to install a device driver. It also lists the required interfaces for CRS451V and CRS456V models: A200 Sensor to PC Interface and PN 28838 ten-position terminal to DB9 terminal block. A note states that the A200 USB driver should be installed automatically when the port is plugged into a computer with a working internet connection, or it can be installed from a Resource DVD or from the website <http://www.campbellsci.com/a200-support>.

5. After making a USB connection to your computer, click the **Connect** button.

## 7.4 Configure CRS45X for measurements

1. Click **Configuration**.
2. Select **Create New Configuration** button located at lower left of screen.
3. Select the type of measurements you want to make.
  - a. Do not select the Barometer Pressure Reference. This option is for other sensor models.
  - b. Disable: To preserve battery between deployments always configure the sensor for storage after use.

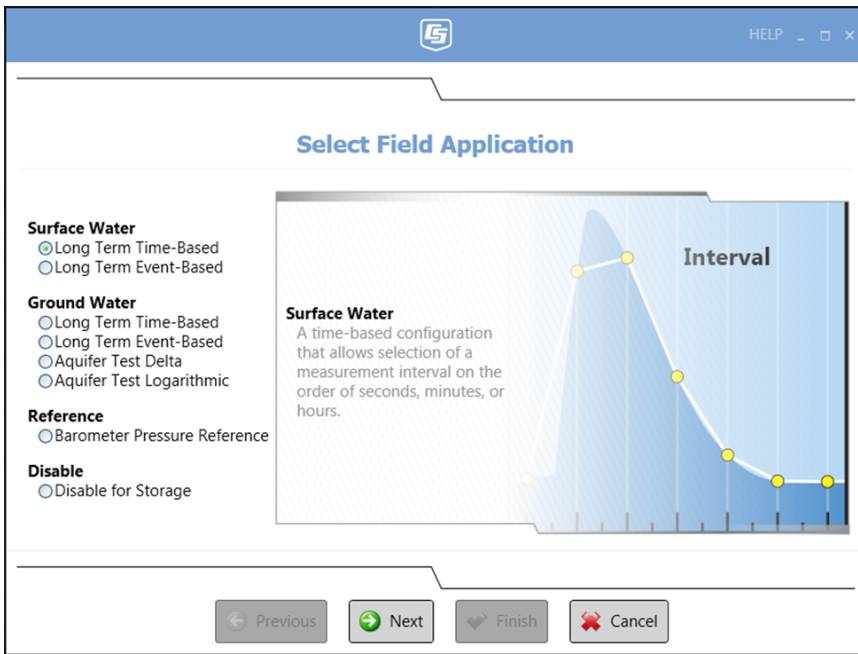

4. Add offset to relate water level measurements to a known datum or reference point. (Aquifer test start at level 0.)
  - a. This step is optional and not required.
  - b. This offset takes effect at the Start Time—which is set in a subsequent screen—so it is necessary that this sensor be in its permanent measurement position before the Start Time, otherwise the offset correction will not be correct.

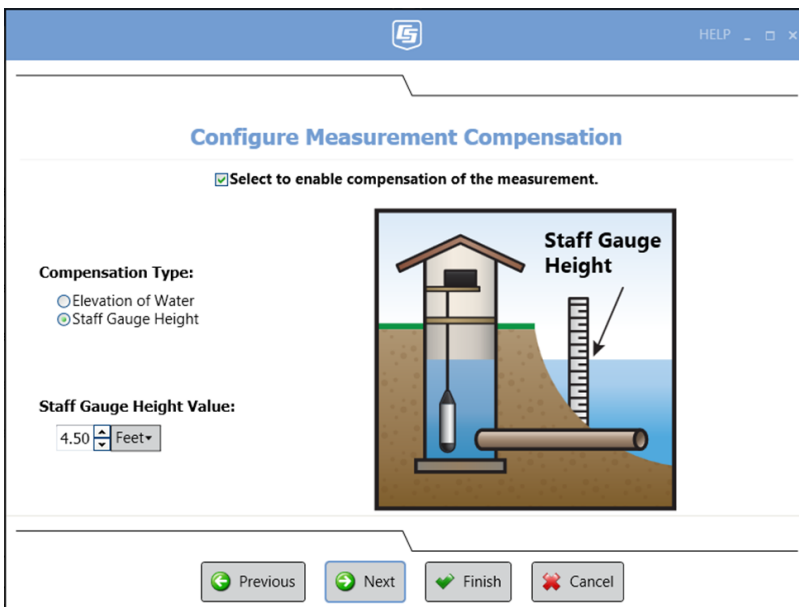

5. Select a **Start** and **Stop Time**.

- a. Select a time in the future when measurements should begin. Selecting a time in the past will force the sensor to begin making measurements immediately at the indicated frequency. If an offset calculation was selected in the previous screen, the sensor will not make correct measurements. If an offset calculation is needed, a Start Time must be selected far enough in the future that the sensor can be properly placed in its measurement position before measurements begin.
- b. If desired, select time in future when measurements should cease.
- c. Select the rate at which measurements will be made. This does not configure the sensor for data storage, only the rate at which measurements are made.

## 6. Select and Name Data Tables for Datalogging.

- a. Up to four different Data Tables can archive data at independent intervals with any combination of elements (samples, averages, maximum, etc).
- b. Contents of the **Data Table** are selected in the next screen.

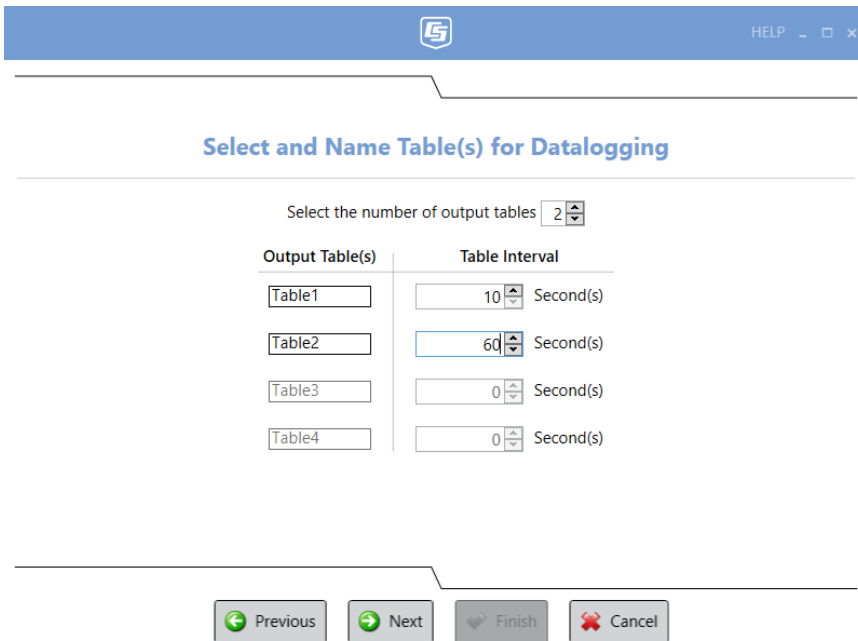

7. Select which data, in which format and unit of measurement, is to be included in each of the data tables selected in the previous screen.

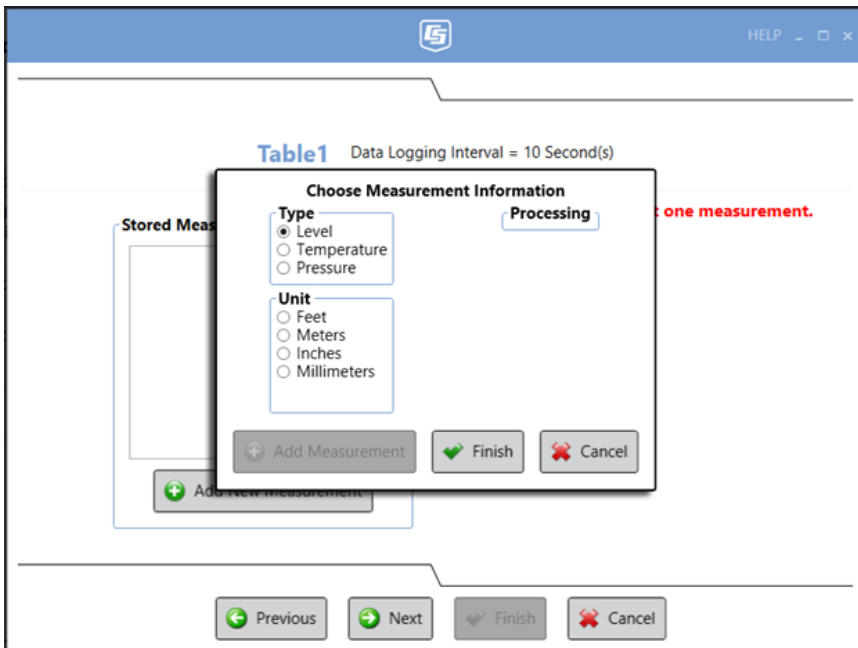

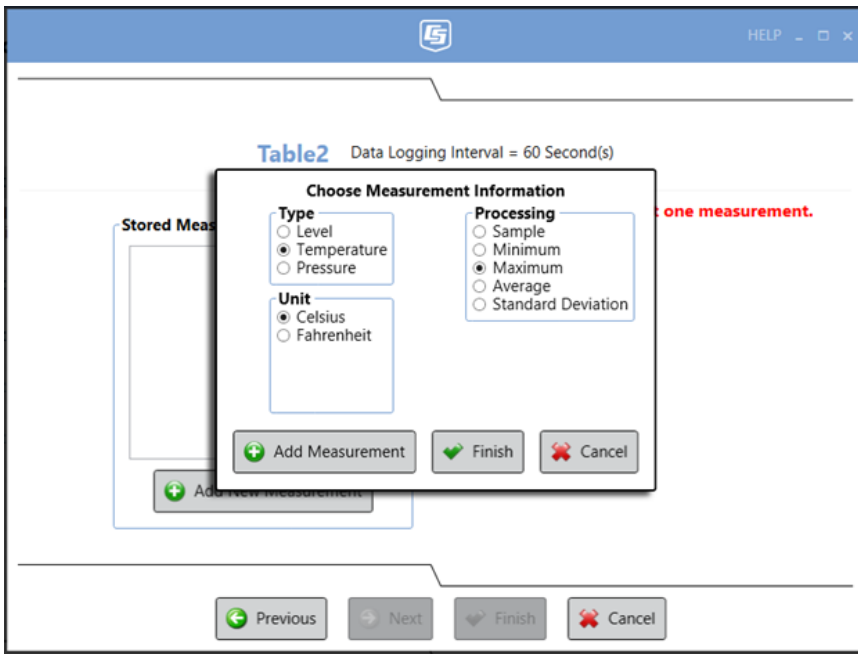

8. Once the **Data Tables** have been configured, the configuration process is finished and the **Finish** button can be selected.
9. Once the configuration is complete, it must be copied to the CRS451V/CRS456V before it will take effect. Click on **Apply Configuration to CRS45X** to start this process.

Before sending the configuration file to the CRS45X, HydroSci may provide a warning that your start and stop times may need adjusting. If the Start Time is in the past, the CRS45X will immediately begin logging data but any offset you may have applied will not be effective. Also, if the Stop Time is in the past, no data will be logged.

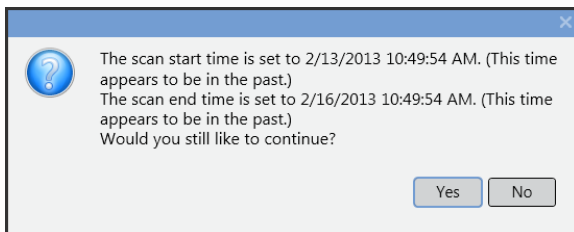

Save data if you have not already done so. Archived data is purged from the CRS45X when a new configuration file is copied so you will want to collect any data before sending the configuration file.

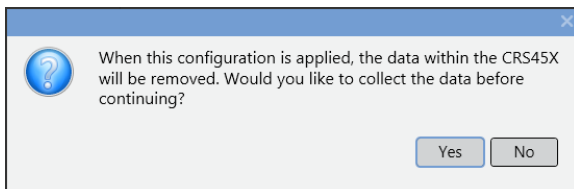

This option allows you to save the configuration file for future reference or for easy use in other similarly deployed sensors.

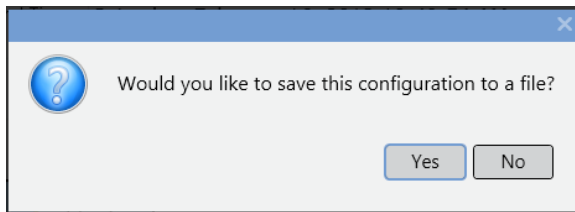

The CRS451V/CRS456V is calibrated to pressure units in psi. [Table B-1](#) (p. 27) contains the conversion factors used to convert psi to depth of water.

## 8. Maintenance

---

Campbell Scientific recommends that the CRS451V/CRS456V be factory recalibrated every 24 months. Before a CRS451V/CRS456V is sent to Campbell Scientific, the customer must get an RMA (returned material authorization) number and fill out the Declaration of Hazardous Material and Decontamination form.

### 8.1 Every visit

- Collect data.
- Visually inspect the physical conditions.
- Check battery condition by using a laptop and HydroSci software to view the battery voltage (see [Battery voltage reading](#) (p. 7)). The battery replacement procedure is provided in [Battery replacement](#) (p. 18).
- Check all readings; adjust offsets if necessary.
- Check recent data.

### 8.2 Every two to three years or on a rotating schedule

- Send the CRS451V/CRS456V in for inspection and calibration.

## 8.3 Battery replacement

A video that describes CRS451V/CRS456V battery replacement is available at: [www.campbellsci.eu/videos/crs451crs456-sensors-battery-replacement](http://www.campbellsci.eu/videos/crs451crs456-sensors-battery-replacement). Remove the set screws on the cap end of the CRS451V/CRS456V.

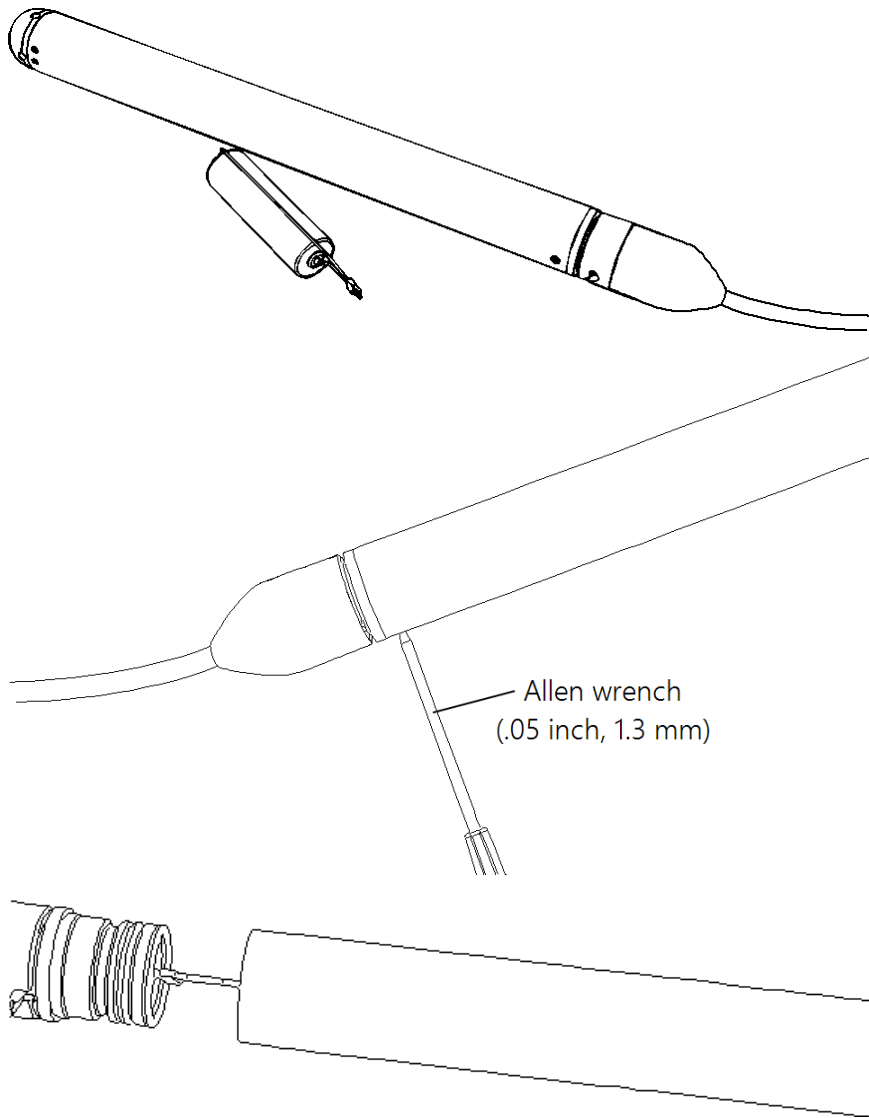

Gently pull the end out of the housing.

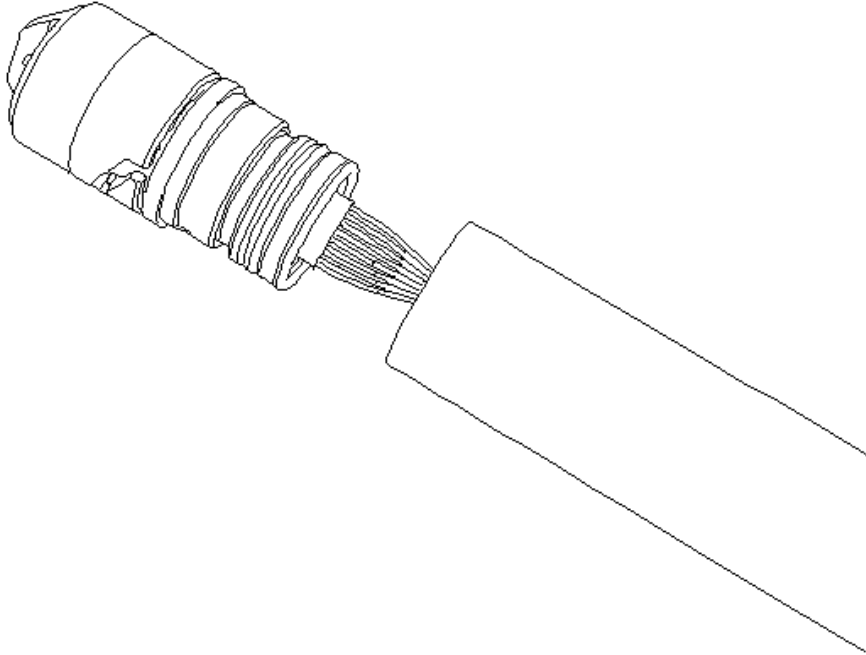

Unplug the connector.

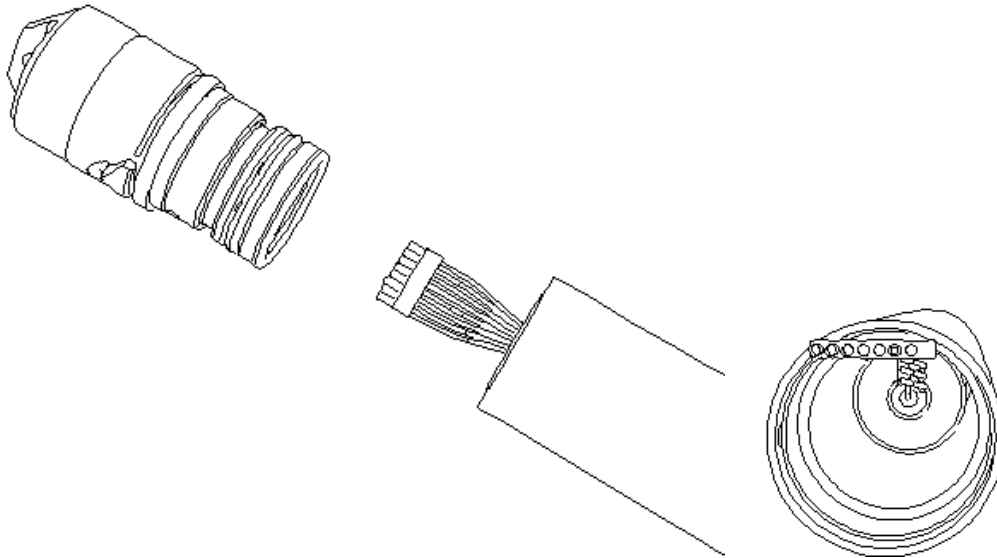

Gently pull the battery out the end.

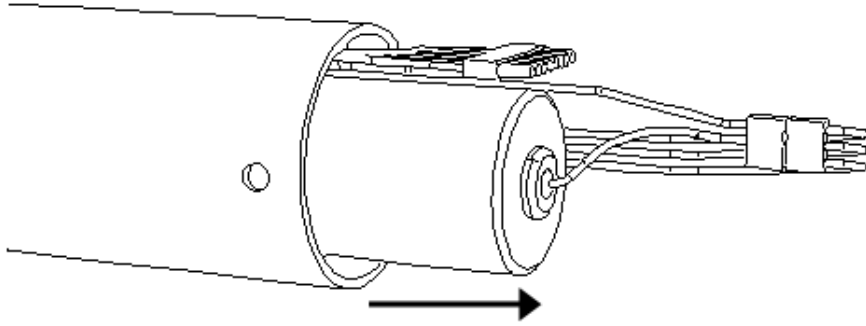

Disconnect the battery.

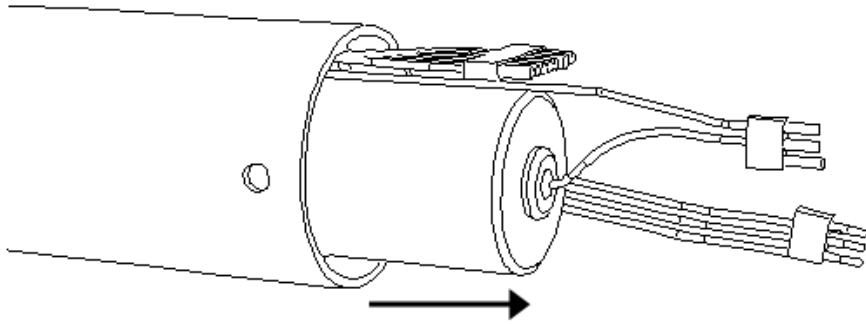

Remove the battery.

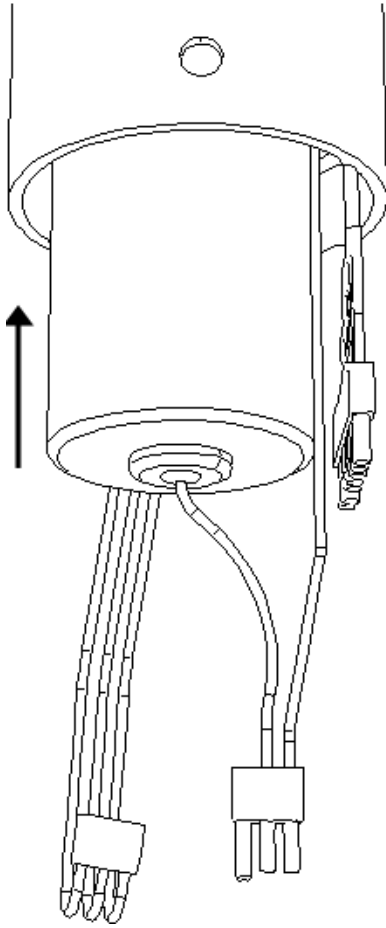

Slide in the new battery.

Plug in the new battery.

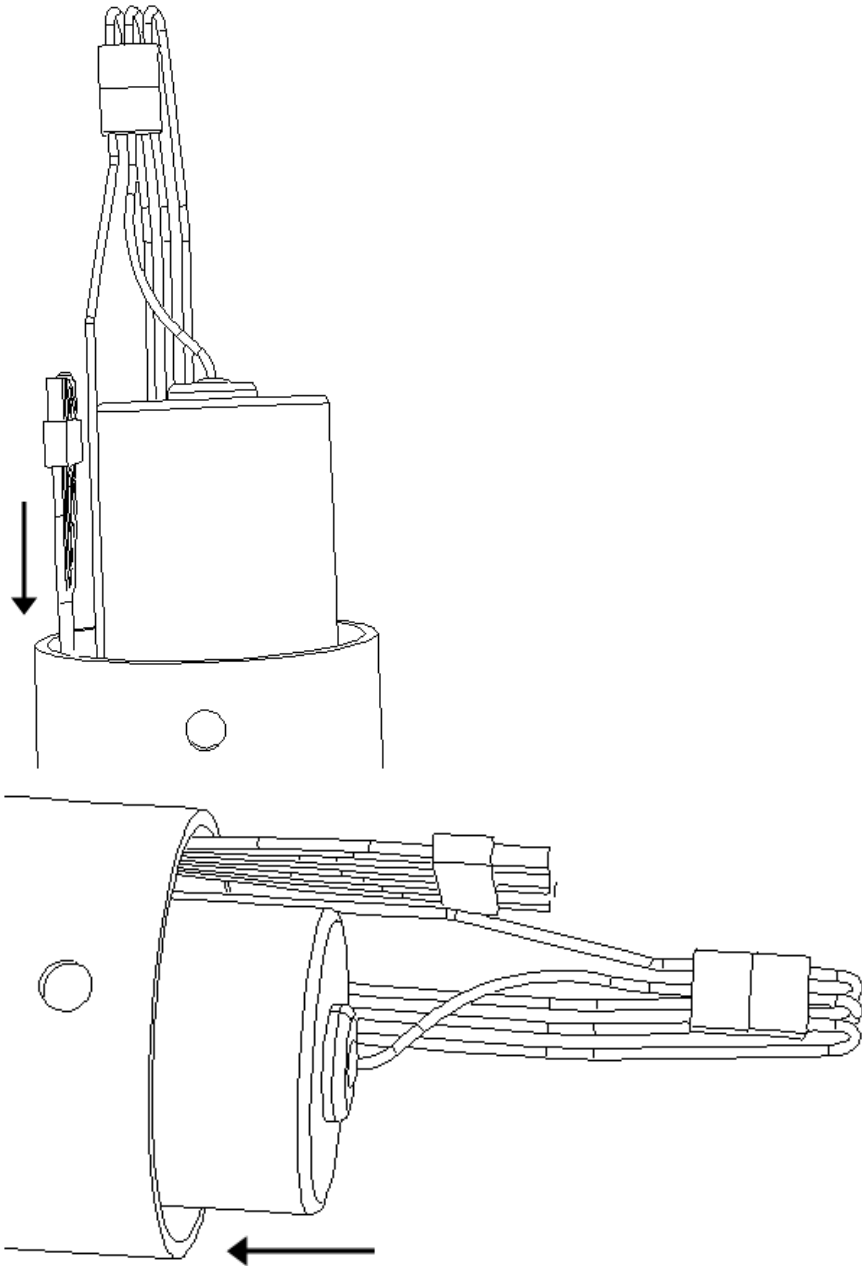

Slide the battery into the housing.

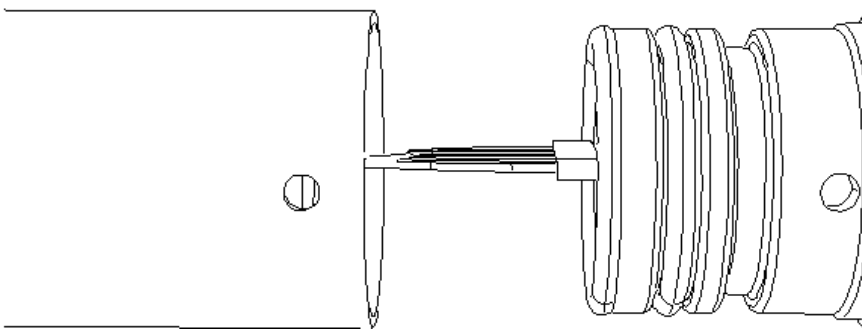

Reconnect the cable.

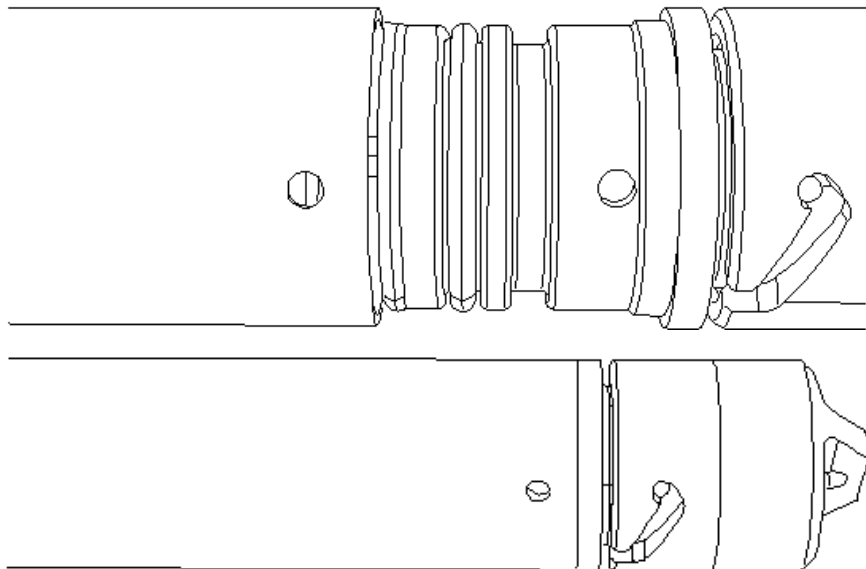

Gently slide the end piece with its O-rings into the housing.

**CAUTION:**

Nicking the O-ring could result in a leak.

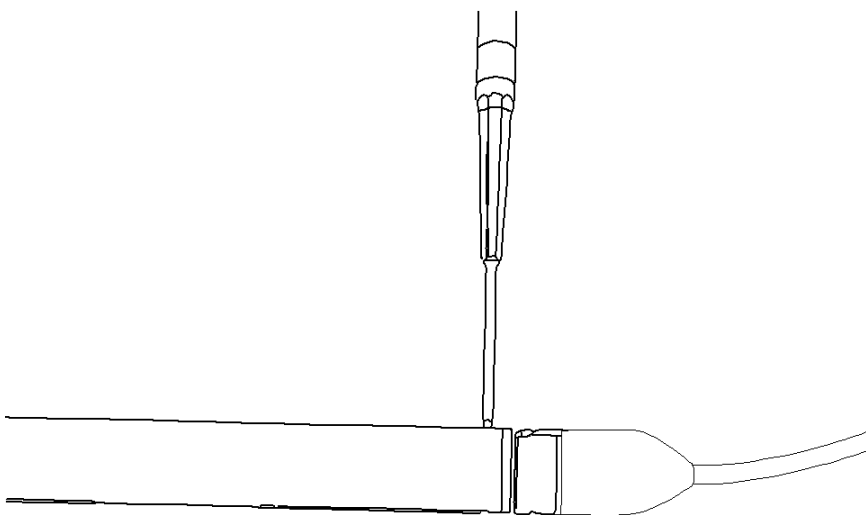

Line up the holes and insert the set screw. Do not over tighten the set screw.

# 9. Troubleshooting

---

The most common causes for erroneous pressure transducer data include:

- Low battery
- Damaged CRS451V/CRS456V
  - Water damage
  - Damage to diaphragm due to excessive pressure
  - Damaged cable or restricted vent tube
- Moisture in vent tube

## **Problem:**

Cannot communicate with CRS451V/CRS456V through A200 when using Device Configuration Utility, LoggerNet, PC400, or PC200W.

- Verify that the sensor cable is attached correctly to the A200.
- Verify that the USB driver for the A200 is installed
- Ensure that the correct COM port is selected for the A200
- Verify that the correct baud rate is set in the software

## **Problem:**

Cannot communicate with CRS451V/CRS456V using a communication device

- Verify that sensor cable is attached correctly to the DB9 terminal adapter:
  - White connects to Terminal # 3
  - Blue connects to Terminal # 2
- Verify that the sensor is being powered by 12 VDC:
  - Red connects to +12Vdc
  - Black connects to Gnd
- Ensure that the baud rates for both the telemetry device and the sensor match
- Verify that the correct PakBus Address is entered in LoggerNet

- Try attaching a wire between the Gnd terminal (#10) on the DB9 terminal connector and Gnd terminal of power source



# Appendix A. Calibration certificate

---

Each CRS451V/CRS456V has been calibrated to meet printed accuracy specification at multiple temperature and pressure ranges. If additional verification is required, a Calibration Certificate can be purchased for each CRS451V/CRS456V Water-Level Recording Sensor.

The Instrument Data Report provides a list of the pressure and temperature at which the sensor was tested.

**Pressure [kPa]** is the pressure applied (listed in kilopascals) to the sensor. **Temperature [°C]** is the temperature inside the test chamber at the time of testing. **Pressure After [kPa]** represents the resulting measurement output by the CRS451V/CRS456V at the given pressure and temperature. Finally, **Deviation After [%F.S.]** provides the difference between the actual pressure applied to the sensor and the pressure measurement output by the sensor. This value is listed as a percentage of the full scale range of the sensor.

When a CRS451V/CRS456V is returned to Campbell Scientific for calibration, the sensor will be returned with an Instrument Data Report. This report will include values in the **Pressure Before [kPa]** column. These values represent the measured pressure the sensor returns at the specified pressure and temperature, before calibration.



# Appendix B. Conversion to units of measurement

---

Table B-1 (p. 27) provides the conversion factors used to convert psi to other units. For example, 1 psi = 2.30666587369 ft.

Table B-1: PSI conversion factors	
Unit of measurement	Factor of conversion
Feet	2.3066587369
Inches	27.679904843
Metres	0.1019716213
Millimetres	101.9716213

# Global Sales & Support Network

A worldwide network to help meet your needs



## Australia

*Location:* Garbutt, QLD Australia  
*Phone:* 61.7.4401.7700  
*Email:* [info@campbellsci.com.au](mailto:info@campbellsci.com.au)  
*Website:* [www.campbellsci.com.au](http://www.campbellsci.com.au)

## Brazil

*Location:* São Paulo, SP Brazil  
*Phone:* 11.3732.3399  
*Email:* [vendas@campbellsci.com.br](mailto:vendas@campbellsci.com.br)  
*Website:* [www.campbellsci.com.br](http://www.campbellsci.com.br)

## Canada

*Location:* Edmonton, AB Canada  
*Phone:* 780.454.2505  
*Email:* [dataloggers@campbellsci.ca](mailto:dataloggers@campbellsci.ca)  
*Website:* [www.campbellsci.ca](http://www.campbellsci.ca)

## China

*Location:* Beijing, P. R. China  
*Phone:* 86.10.6561.0080  
*Email:* [info@campbellsci.com.cn](mailto:info@campbellsci.com.cn)  
*Website:* [www.campbellsci.com](http://www.campbellsci.com)

## Costa Rica

*Location:* San Pedro, Costa Rica  
*Phone:* 506.2280.1564  
*Email:* [info@campbellsci.cc](mailto:info@campbellsci.cc)  
*Website:* [www.campbellsci.cc](http://www.campbellsci.cc)

## France

*Location:* Vincennes, France  
*Phone:* 0033.0.1.56.45.15.20  
*Email:* [info@campbellsci.fr](mailto:info@campbellsci.fr)  
*Website:* [www.campbellsci.fr](http://www.campbellsci.fr)

## Germany

*Location:* Bremen, Germany  
*Phone:* 49.0.421.460974.0  
*Email:* [info@campbellsci.de](mailto:info@campbellsci.de)  
*Website:* [www.campbellsci.de](http://www.campbellsci.de)

## South Africa

*Location:* Stellenbosch, South Africa  
*Phone:* 27.21.8809960  
*Email:* [sales@campbellsci.co.za](mailto:sales@campbellsci.co.za)  
*Website:* [www.campbellsci.co.za](http://www.campbellsci.co.za)

## Southeast Asia

*Location:* Bangkok, Thailand  
*Phone:* 66.2.719.3399  
*Email:* [thitipongc@campbellsci.asia](mailto:thitipongc@campbellsci.asia)  
*Website:* [www.campbellsci.asia](http://www.campbellsci.asia)

## Spain

*Location:* Barcelona, Spain  
*Phone:* 34.93.2323938  
*Email:* [info@campbellsci.es](mailto:info@campbellsci.es)  
*Website:* [www.campbellsci.es](http://www.campbellsci.es)

## UK

*Location:* Shephed, Loughborough, UK  
*Phone:* 44.0.1509.601141  
*Email:* [sales@campbellsci.co.uk](mailto:sales@campbellsci.co.uk)  
*Website:* [www.campbellsci.co.uk](http://www.campbellsci.co.uk)

## USA

*Location:* Logan, UT USA  
*Phone:* 435.227.9120  
*Email:* [info@campbellsci.com](mailto:info@campbellsci.com)  
*Website:* [www.campbellsci.com](http://www.campbellsci.com)