

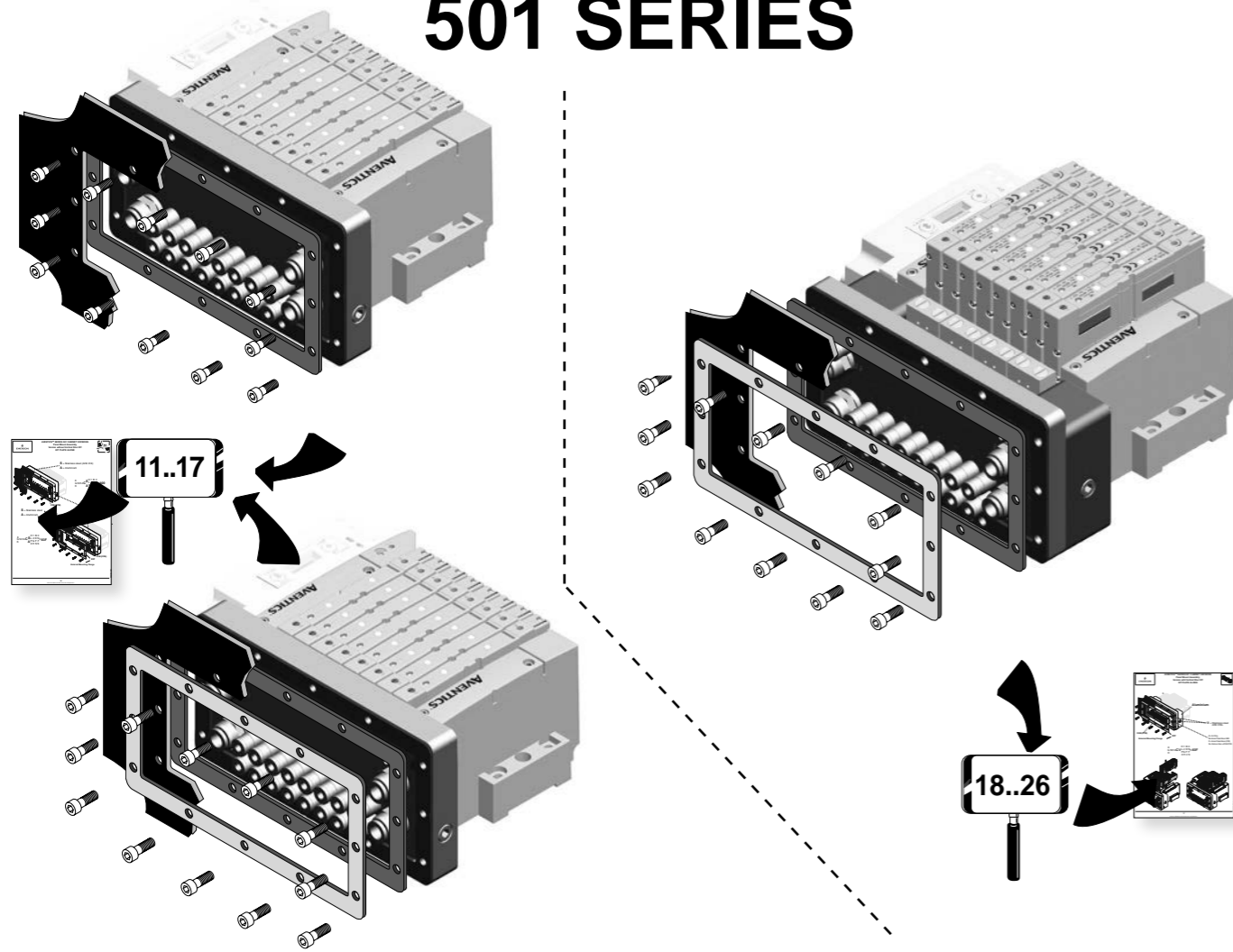

AVENTICS™ SERIES 501 CABINET MOUNTING

INSTALLATION AND MAINTENANCE INSTRUCTIONS	EN
INSTRUCTIONS D'INSTALLATION ET DE MAINTENANCE	FR
INBETRIEBNAHME - UND WARTUNGSANLEITUNG	DE
INSTRUCCIONES DE PUESTA EN MARCHA Y MANTENIMIENTO	ES
ISTRUZIONI DI MESSA IN SERVIZIO E MANUTENZIONE	IT
ALGEMENE INSTALLATIE- EN ONDERHOUDSINSTRUCTIES	NL
INSTALLASJONS- OG VEDLIKEHOLDSINSTRUKSER	NO
INSTALLATIONS- OCH UNDERHÅLLSINSTRUKTIONER	SE
ASENNUS - JA HUOLTO-OHJEET	FI
INSTALLATIONS - OG VEDLIGEHOldsANVISNINGER	DK
INSTRUÇÕES DE INSTALAÇÃO E MANUTENÇÃO	PT
ΟΔΗΓΙΕΣ ΤΟΠΟΘΕΤΗΣΗΣ ΚΑΙ ΣΥΝΤΗΡΗΣΗΣ	GR
POKYNŮ PRO INSTALACI A ÚDRŽBU	CZ
INSTRUKCJA MONTAŻU I KONSERWACJI	PL
TELEPÍTÉSI ÉS KARBANTARTÁSI ÚTMUTATÓ	HU
ИНСТРУКЦИЯ ПО УСТАНОВКЕ И ОБСЛУЖИВАНИЮ	RU
ОРНАТУ ЖӘНЕ ҚЫЗМЕТ КӨРСЕТУ НҰСҚАУЛАР	KZ

CABINET MOUNTING 501 SERIES



506366-001 / BA
Availability, design and specifications are subject to change without notice. All rights reserved.

		AVENTICS™ SERIES 501 QUICK FITTING 4-6 mm (2 - 4 ports)		rated flow l/min 6,3 bar l/min (ANR)	T (ms) o / c (ms)	14 P _p (bar) (23°C) min. max.	1 P (bar) min. max. (PS)
2 x 3/2 NC	K		(14) (12)	405 415 1→2 2→3 1→4 4→5	18 / 18	(a) 8	2 8
2 x 3/2 NO	N			400 400	18 / 18	(a) 8	2 8
2 x 3/2 NC - NO	H			405 415 400 400	18 / 18	(a) 8	2 8
2 x 3/2 NO - NC	P			400 400 405 415	18 / 18	(a) 8	2 8
5/2	S			405 410	14 / 29	2 8	-0,95 8
	M			405 410	25 / 21	2 8	-0,95 8
	J			405 410	11 / 11	2 8	-0,95 8
5/3	G	 W1		405 410	13 / 12	2 8	-0,95 8
	B	 W2		405 360	17 / 38	2,5 8	-0,95 8
	E	 W3		365 415	27 / 12	2 8	-0,95 8

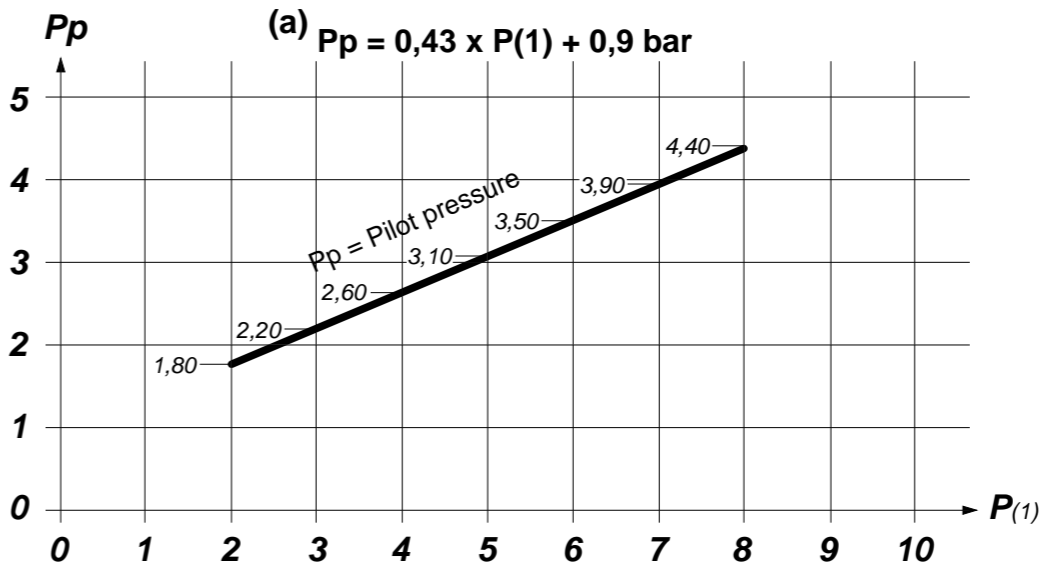



AVENTICS™ SERIES 501 CABINET VERSIONS

(P = Panel Mount)
ASSEMBLY KIT
 (W/ or W/o Plates)

G3
 580
 25 / 27
 1-32
 19 / 26

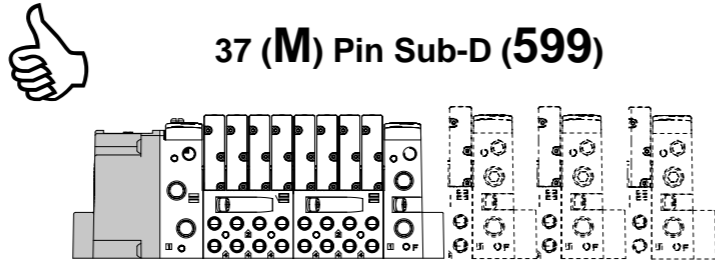
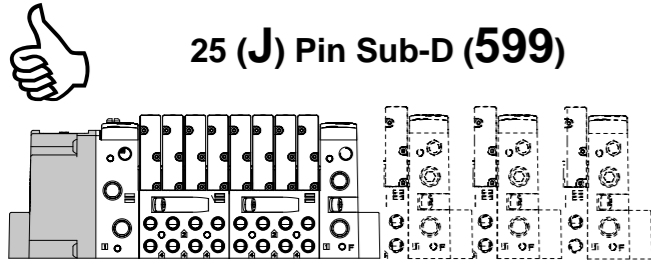
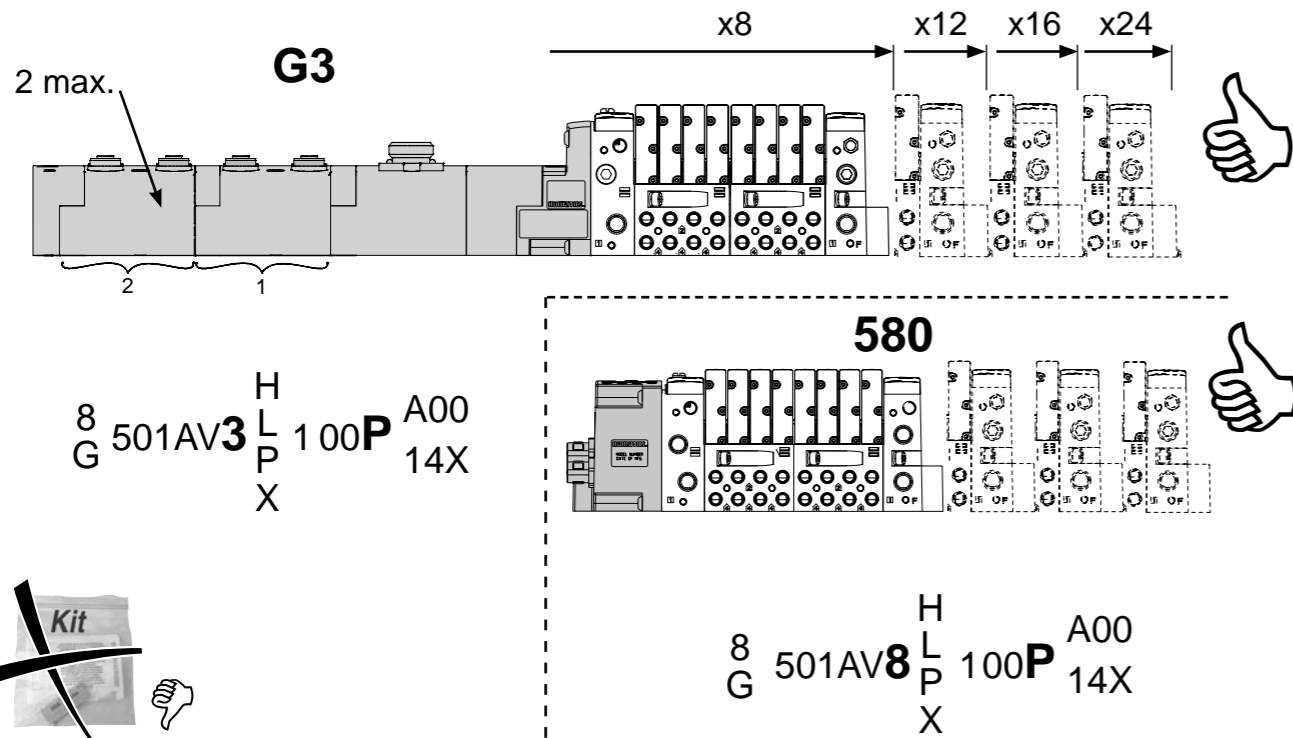

8 G 501AV **J** H L P X 1 00 P A00 14X

TABLE 1		max. coils
25 Pin Sub-D		22
37 Pin Sub-D		32
1-32 Terminal Strip		16
19 Pin Round Connector		22
26 Pin Round Connector		22

8 G 501AV **M** H L P X 1 00 P A00 14X

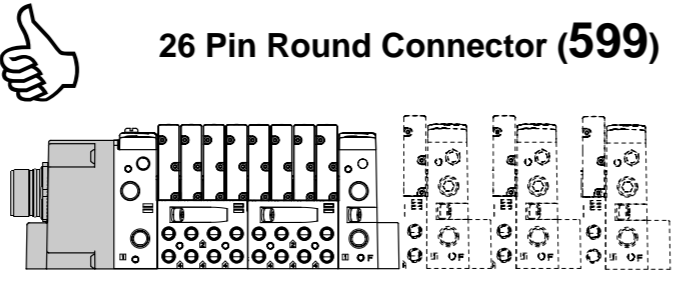
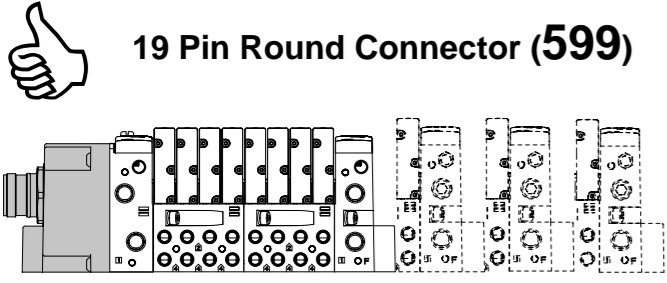

8 G 501AV **Q** H L P X 1 00 P A00 14X

8 G 501AV **R** H L P X 1 00 P A00 14X

506366-001



AVENTICS™ SERIES 501 CABINET VERSIONS

(P = Panel Mount)

G3
 580
 25 / 27
 1-32
 19 / 26

TABLE 1	max. coils
25 Pin Sub-D	22
37 Pin Sub-D	32
1-32 Terminal Strip	16
19 Pin Round Connector	22
26 Pin Round Connector	22
G3	48 ⁽¹⁾ / 32 ⁽²⁾
580	48 ⁽³⁾ / 32 ⁽⁴⁾
580 Charm	48

- (1) PROFIBUS-DP®, PROFINET®, SUB-BUS node, EtherNET/IP™ DLR, EtherCAT®, POWERLINK
- (2) DeviceNet™, CANopen®, DEVICE LOGIX
- (3) PROFIBUS-DP®, PROFINET®, SUB-BUS node, EtherNET/IP™ DLR, EtherCAT®, POWERLINK
- (4) DeviceNet™, CANopen®, IO-Link Class A, IO-Link Class B

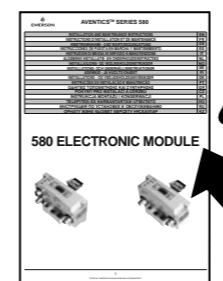

580

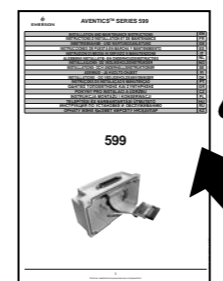

25 / 37 Pin Sub-D
 19 Pin Round Connector
 26 Pin Round Connector

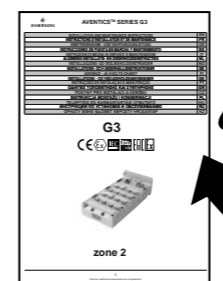

1-32 Terminal Strip
 G3

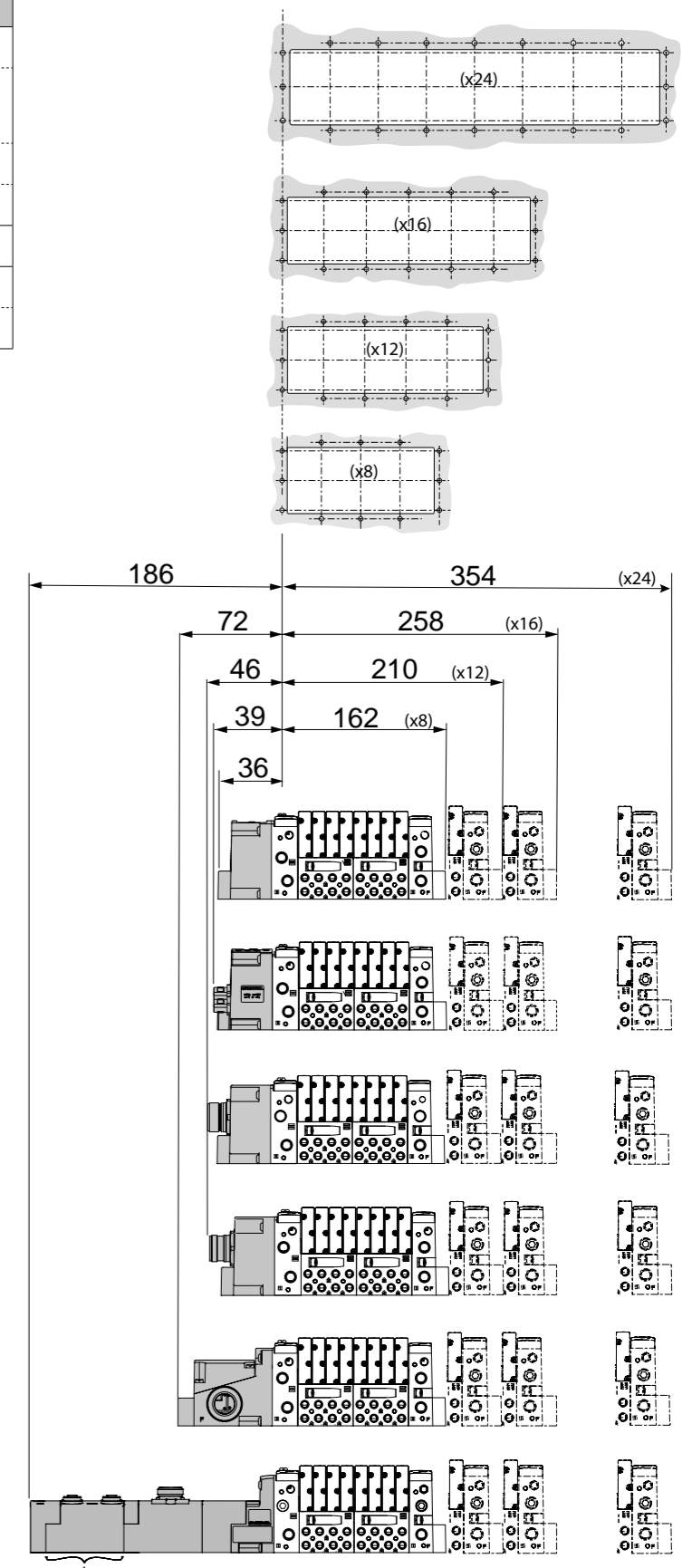

506366-001



AVENTICS™ SERIES 501 CABINET VERSIONS
(Q4/P4 = Panel Mount/Subbase)



(standard versions)

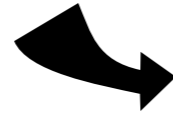

Part No.	Description	Quantity	Notes
5	Kit	1	

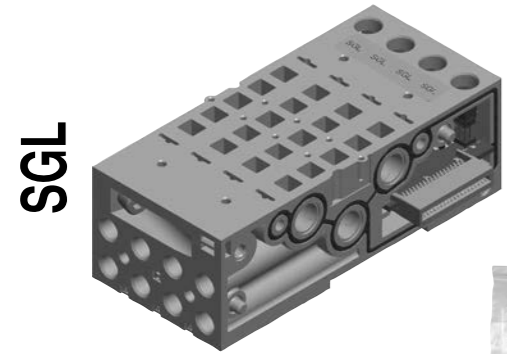
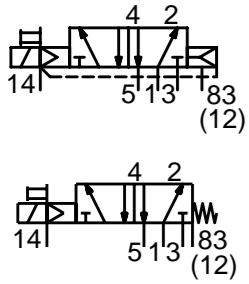

SGL

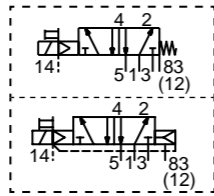

H501AMQ4BMA0010



AVENTICS™ SERIES 501 CABINET VERSIONS
(X-32 Driver)

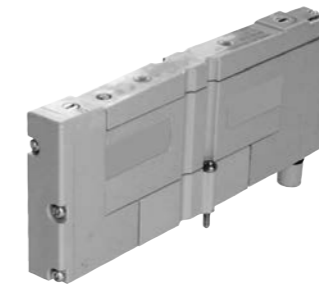

(standard versions)



Part No.	Description	Quantity	Notes
5	Kit	1	

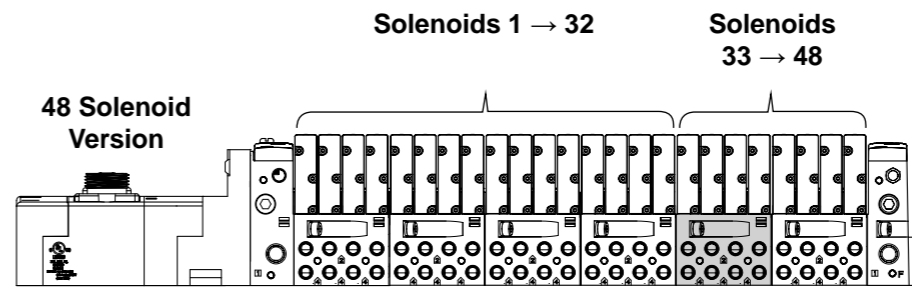

48 Solenoid Version

Solenoids 1 → 32

Solenoids 33 → 48



X-32 Driver



H501AFP4BMA0010

DBL

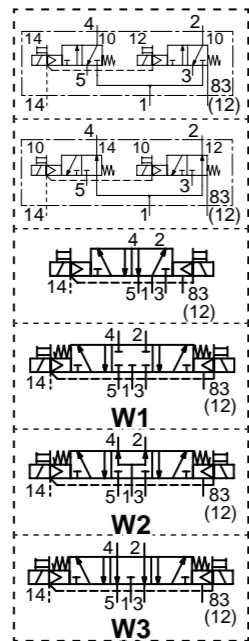
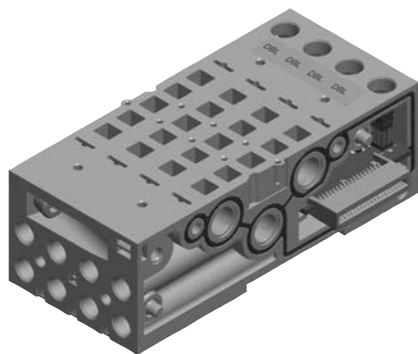

H501AMP4BMA0010

DBL

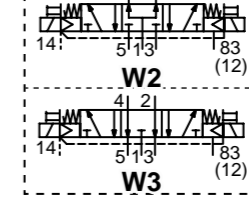
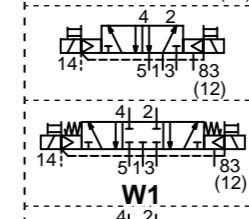
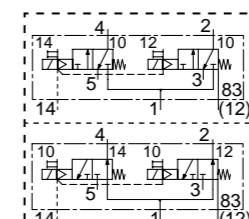
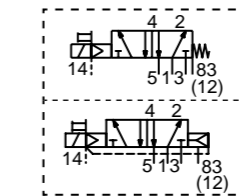
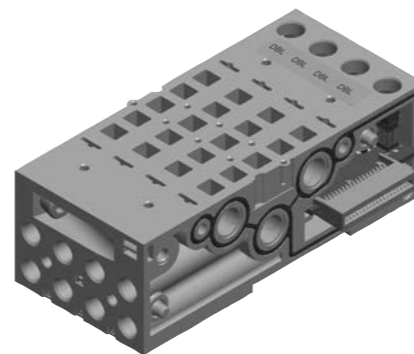



AVENTICS™ SERIES 501 CABINET VERSIONS



AVENTICS™ SERIES 501 CABINET VERSIONS
Panel Mount Assembly
Version without Vertical Shut Off
KIT PLATE ALONE

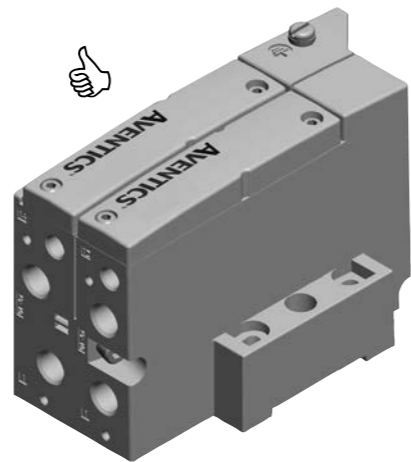
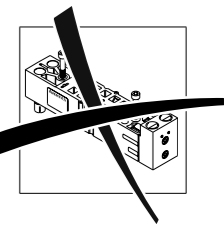

<p>G (ISO 228/1)</p>		<p>G501AK429465026</p>
<p>NPT</p>		<p>8501AK429465025</p>
<p>M7</p>		<p>8501AK429465049</p>

506366-001

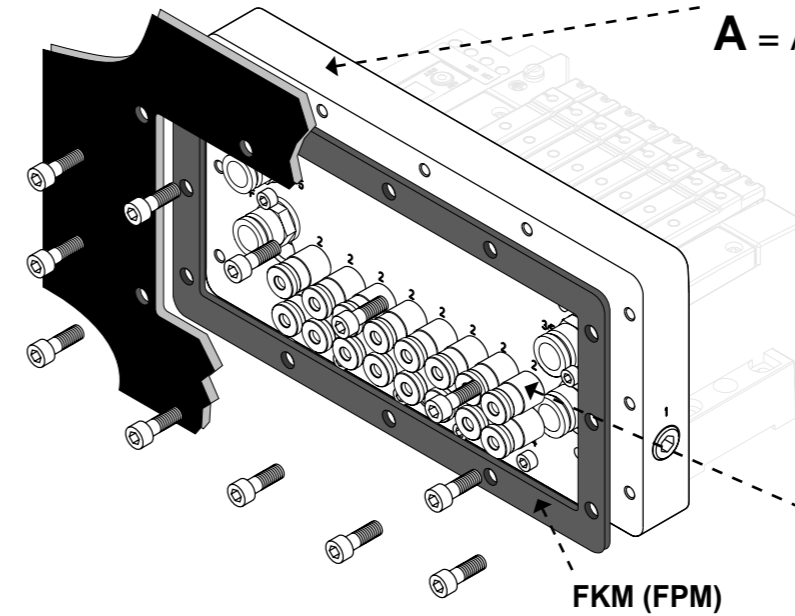

S = Stainless steel (AISI 316)
A = Aluminium

8
 G 501AC S H1 B 0
 K L 2 DN 0 A00
 A P G F F XH 2 S

0 = No fitting
 N = Nickel Plated Brass NBR
 F = Nickel Plated Brass (FPM)
 S = Stainless Steel w/FKM (FPM)

S = Stainless steel
A = Aluminium

8
 G 501AC S H1 B 0
 K L 2 DN 0 83F
 A P G F F XH S S

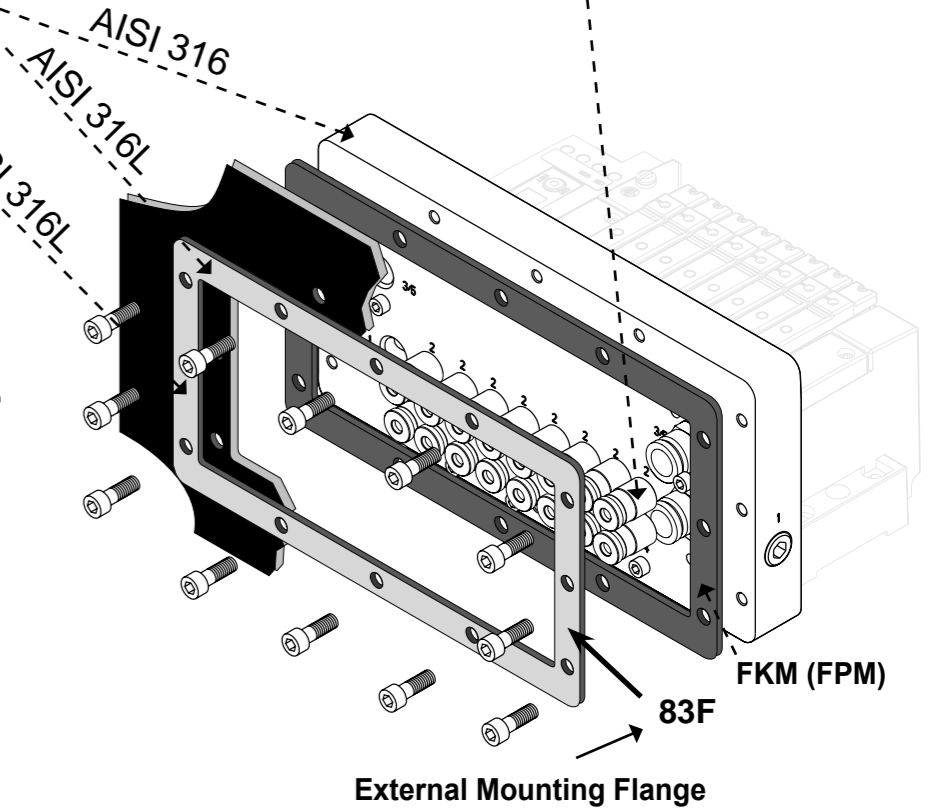

External Mounting Flange

506366-001



AVENTICS™ SERIES 501 CABINET VERSIONS

Panel Mount Assembly

Version without Vertical Shut Off

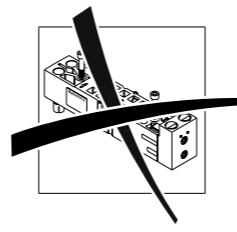

2D/3D CAD models

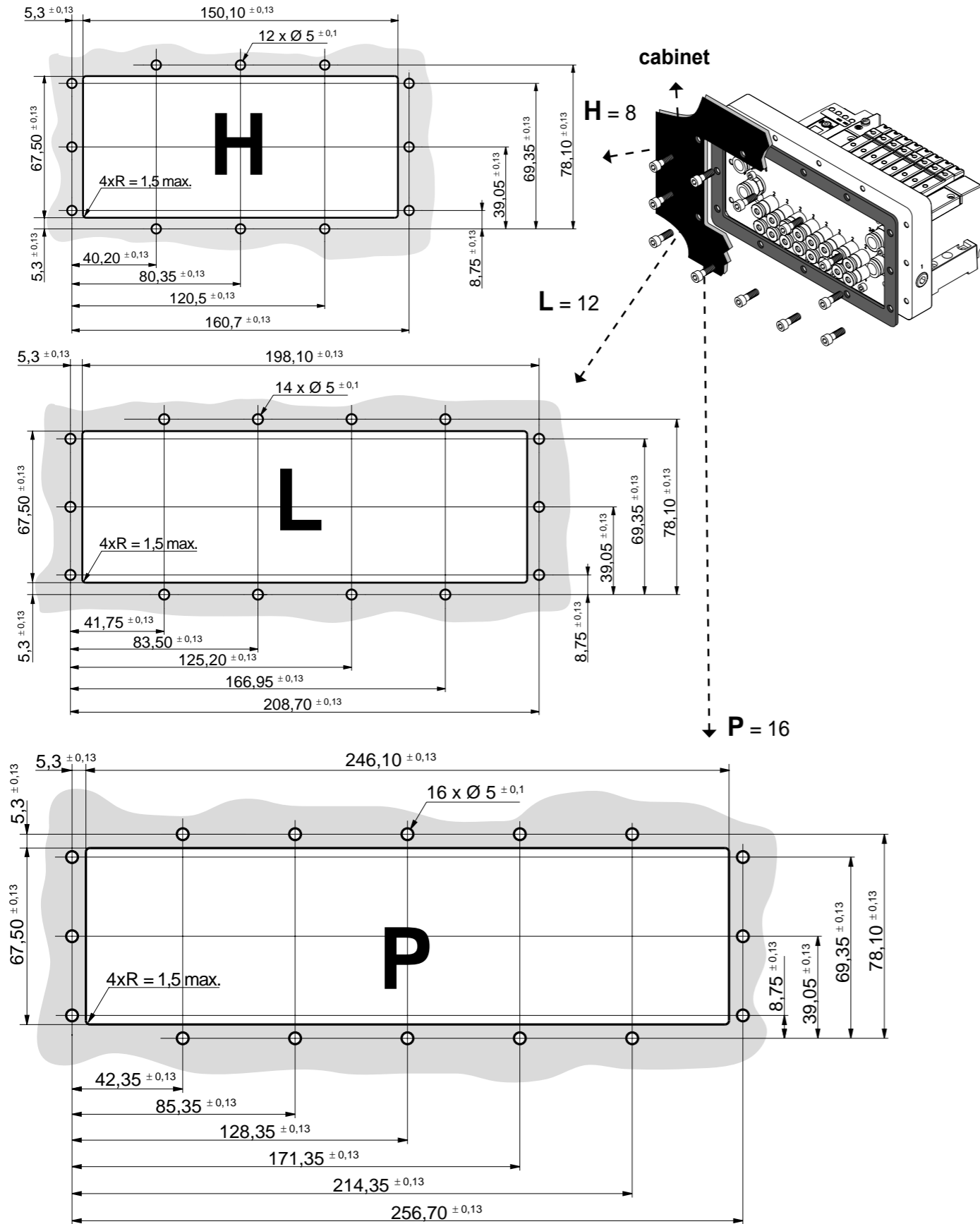

506366-001



AVENTICS™ SERIES 501 CABINET VERSIONS

Panel Mount Assembly

Version without Vertical Shut Off

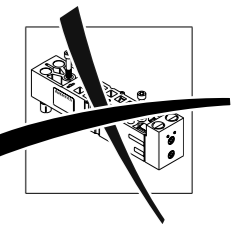

2D/3D CAD models

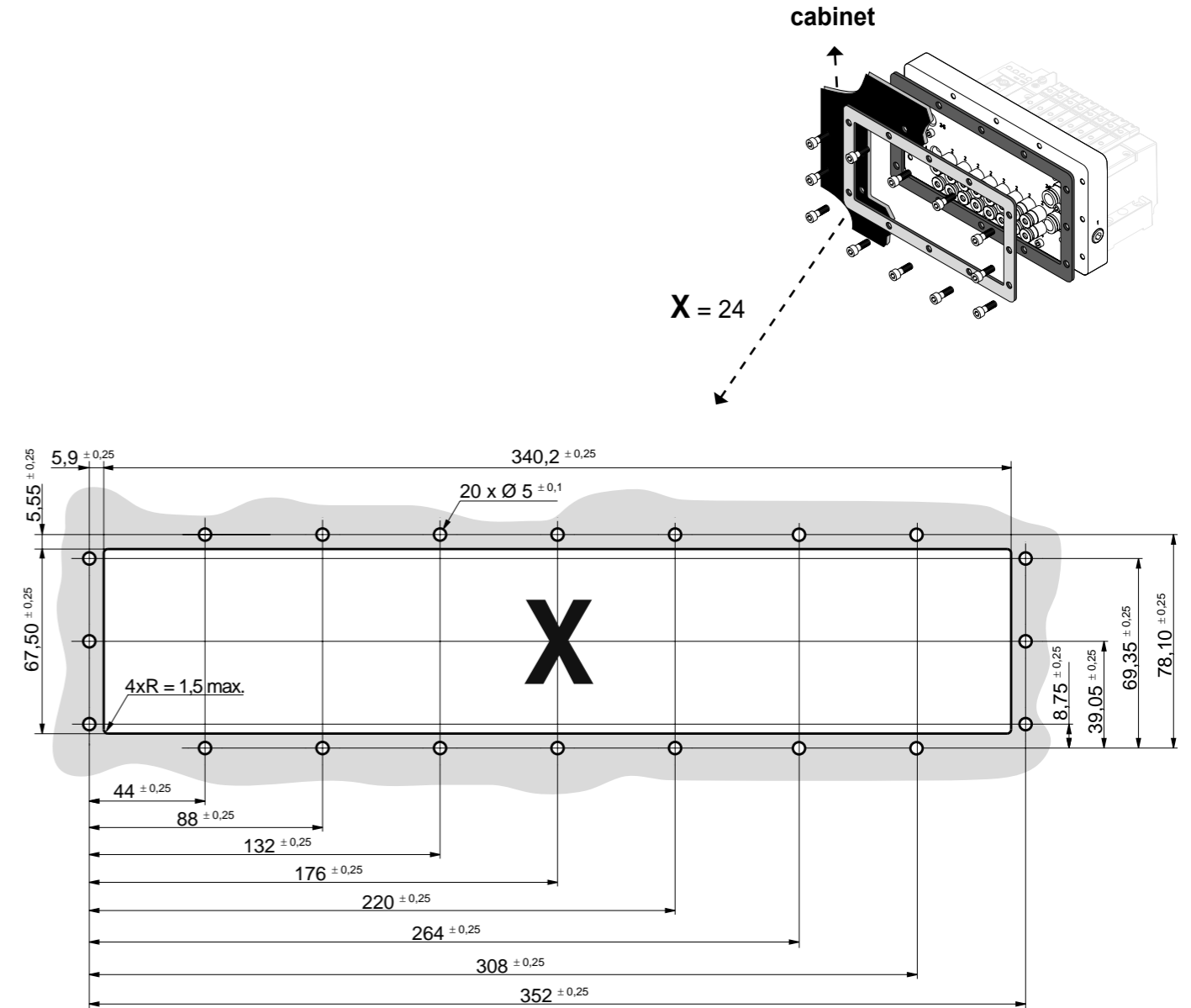

506366-001



AVENTICS™ SERIES 501 CABINET VERSIONS
Panel Mount Assembly
Version without Vertical Shut Off

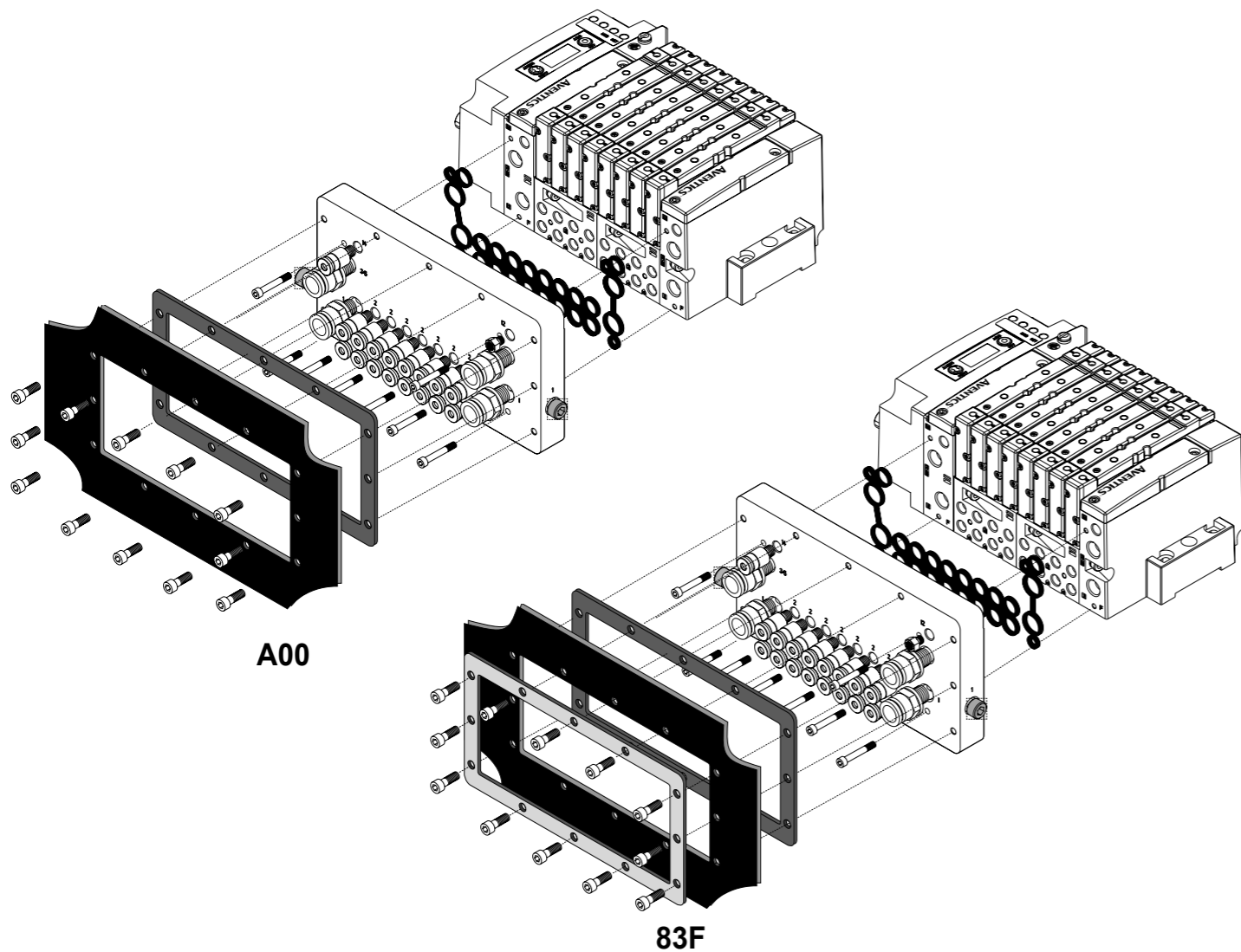
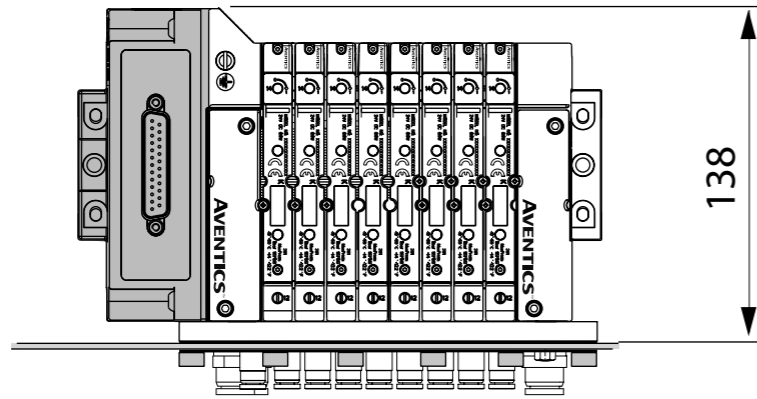
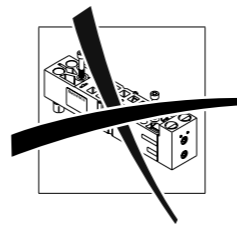

506366-001



AVENTICS™ SERIES 501 CABINET VERSIONS
Panel Mount Assembly
Version without Vertical Shut Off

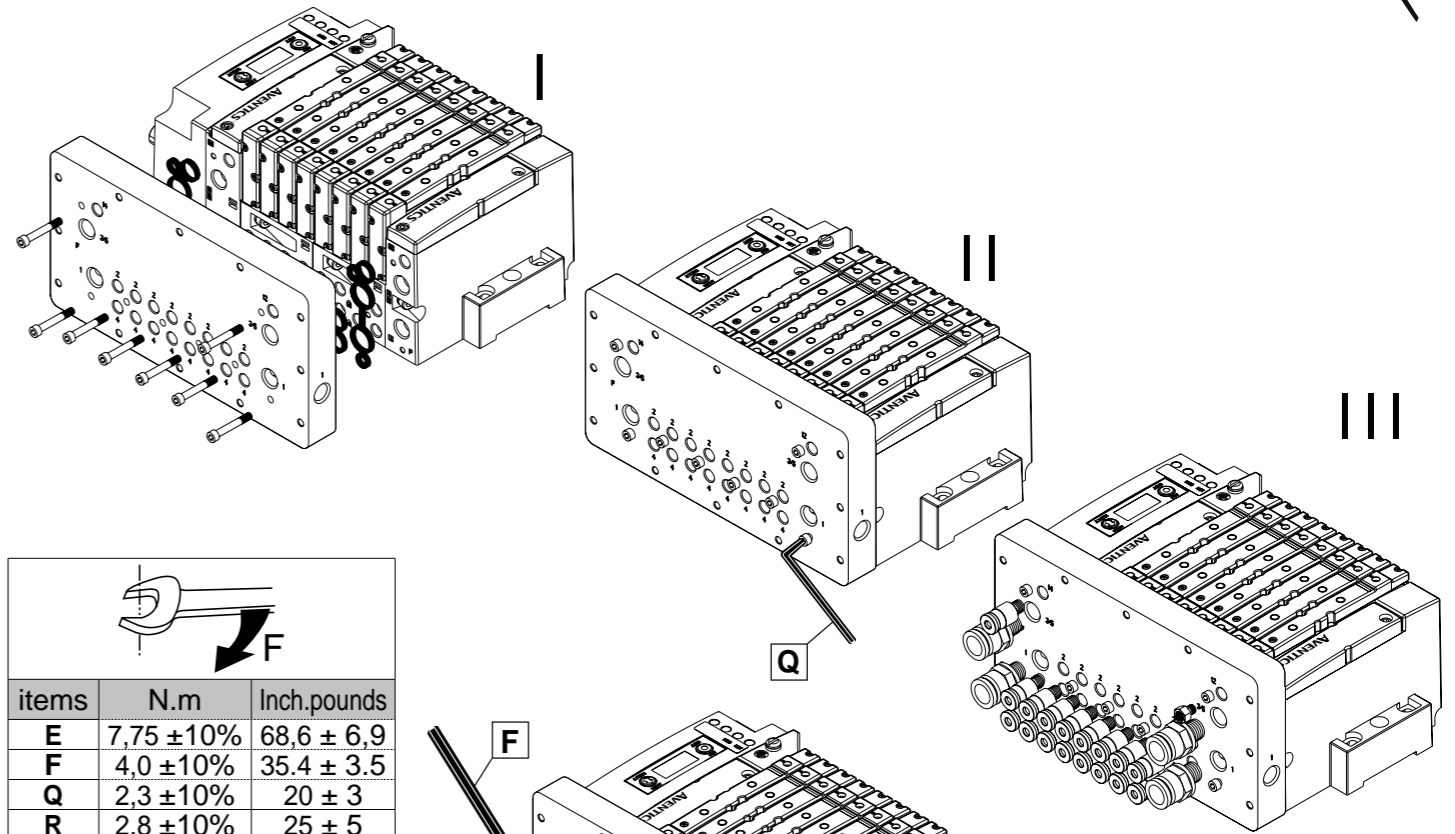
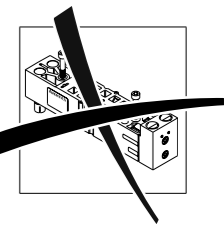

items	N.m	Inch.pounds
E	7,75 ±10%	68,6 ± 6,9
F	4,0 ±10%	35,4 ± 3,5
Q	2,3 ±10%	20 ± 3
R	2,8 ±10%	25 ± 5

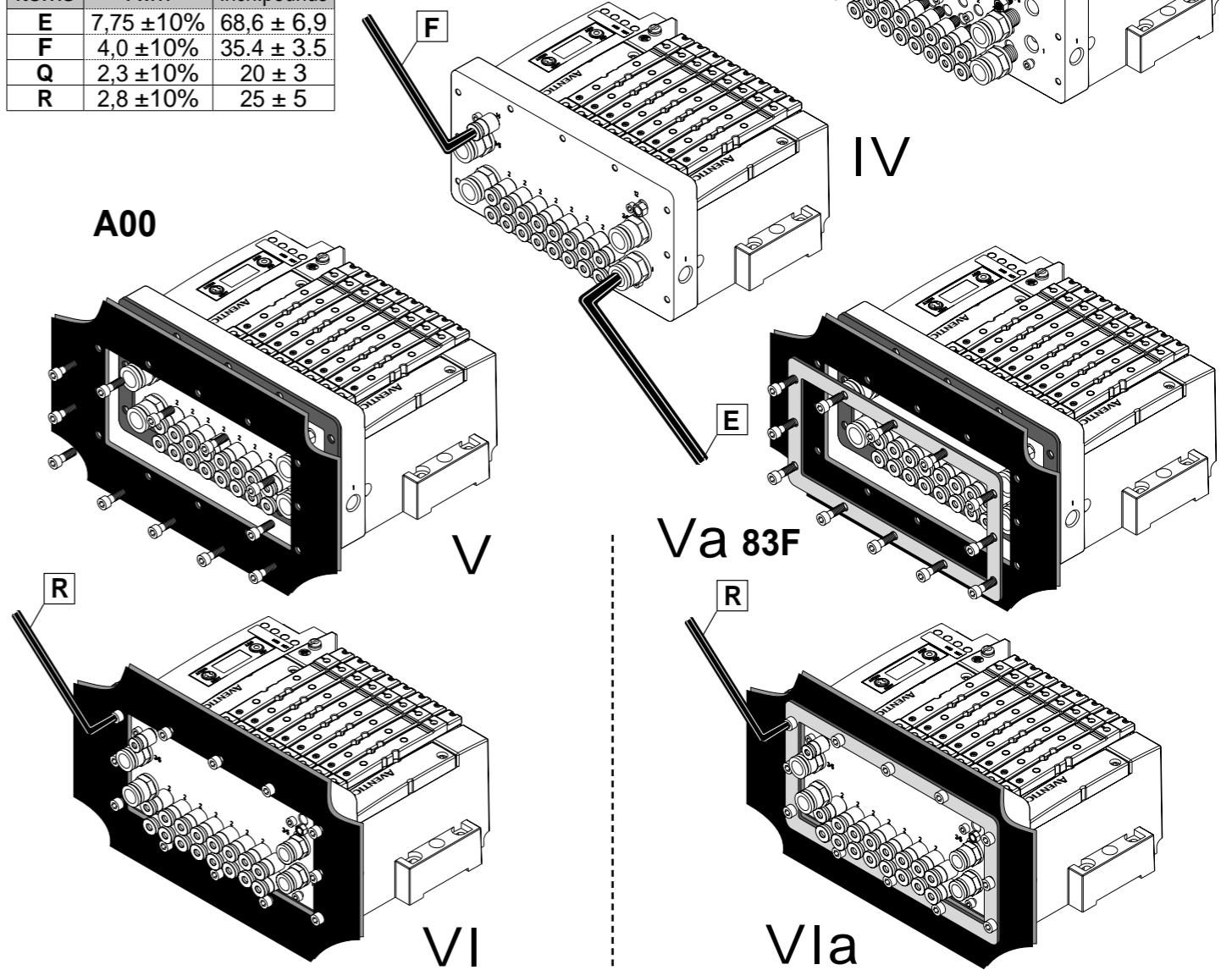

506366-001



AVENTICS™ SERIES 501 CABINET VERSIONS

Panel Mount Assembly

Version without Vertical Shut Off

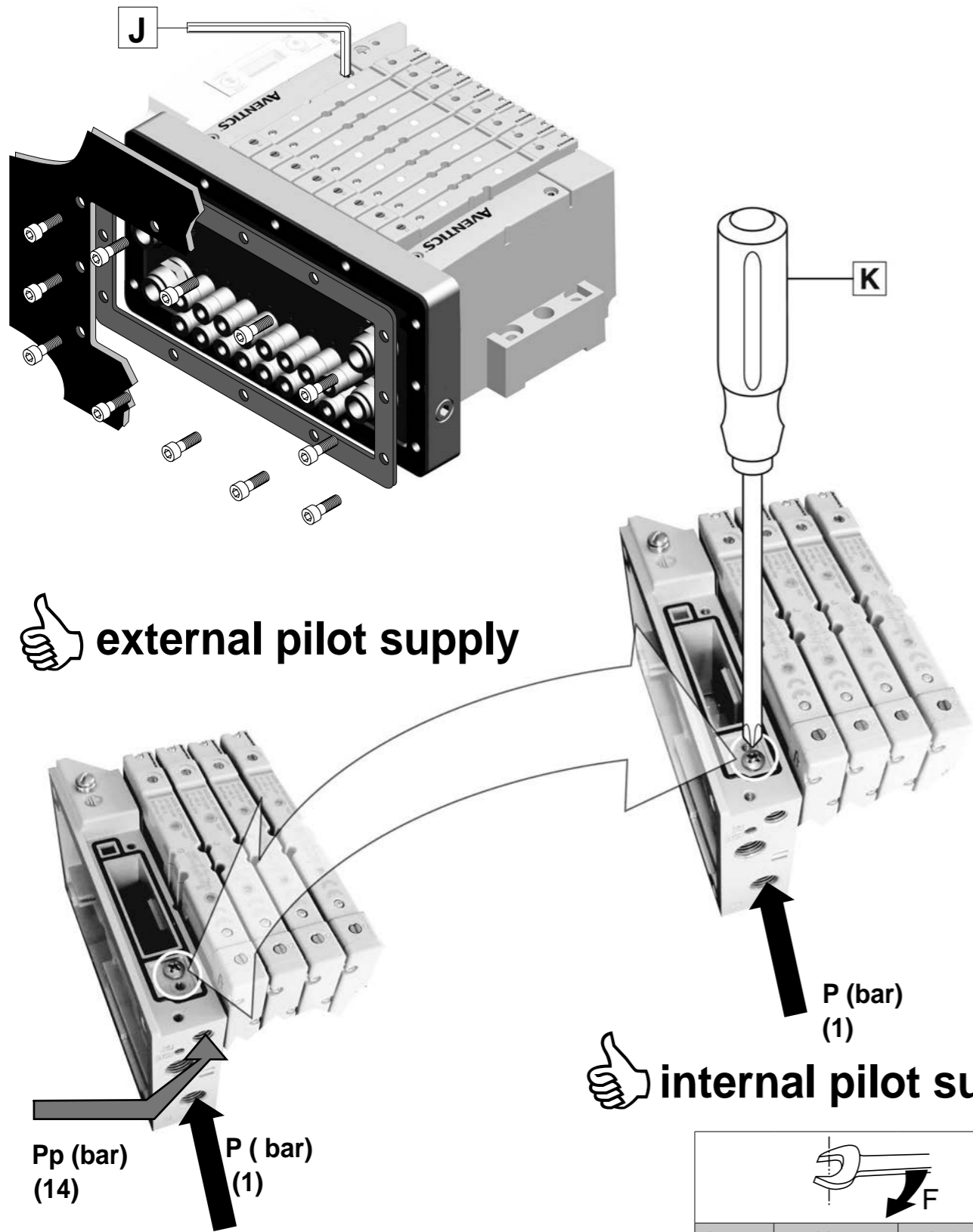
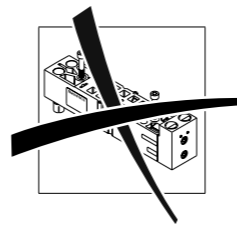

**Pp (bar)
(14)**

**P (bar)
(1)**

**P (bar)
(1)**

thumbs-up icon internal pilot supply

items	N.m	Inch.pounds
K	1,1 ±10%	10 ±1
J	2,4 ±10%	21 ±2.1

506366-001



AVENTICS™ SERIES 501 CABINET VERSIONS

Accessories

Version without Vertical Shut Off

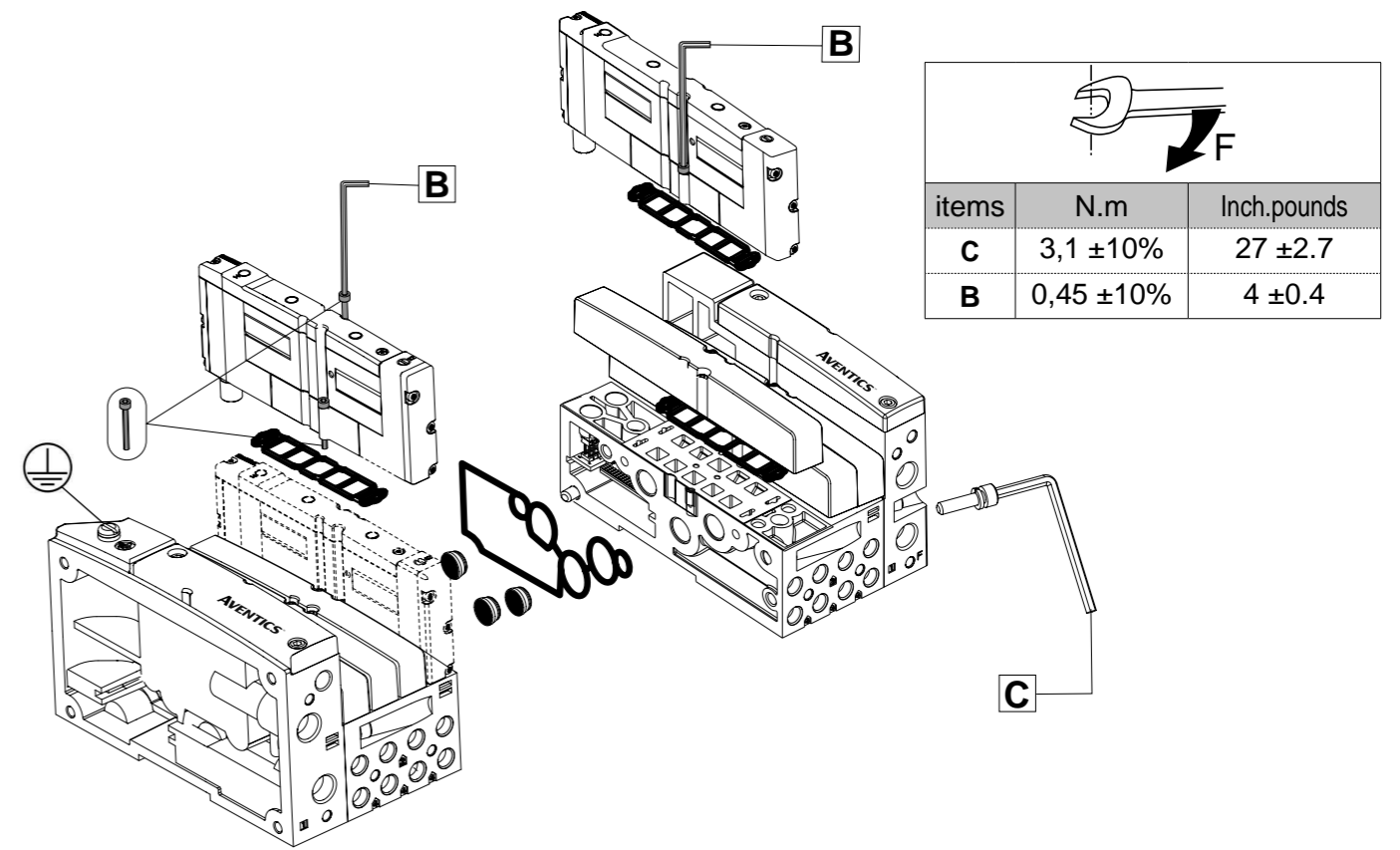
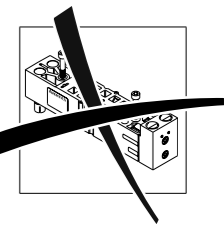

items	N.m	Inch.pounds
C	3,1 ±10%	27 ±2.7
B	0,45 ±10%	4 ±0.4



P501AB429685001



P501AD431915001		+		•	1
P501AD431915002		+		•	3
P501AD431915003		+		•	5
P501AD431915004		+		•	1, 3
P501AD431915005		+		•	1, 5
P501AD431915006		+		•	3, 5
P501AD431915007		+		•	1, 3, 5

506366-001



AVENTICS™ SERIES 501 CABINET VERSIONS
Panel Mount Assembly
Version with Vertical Shut Off
KIT PLATE ALONE

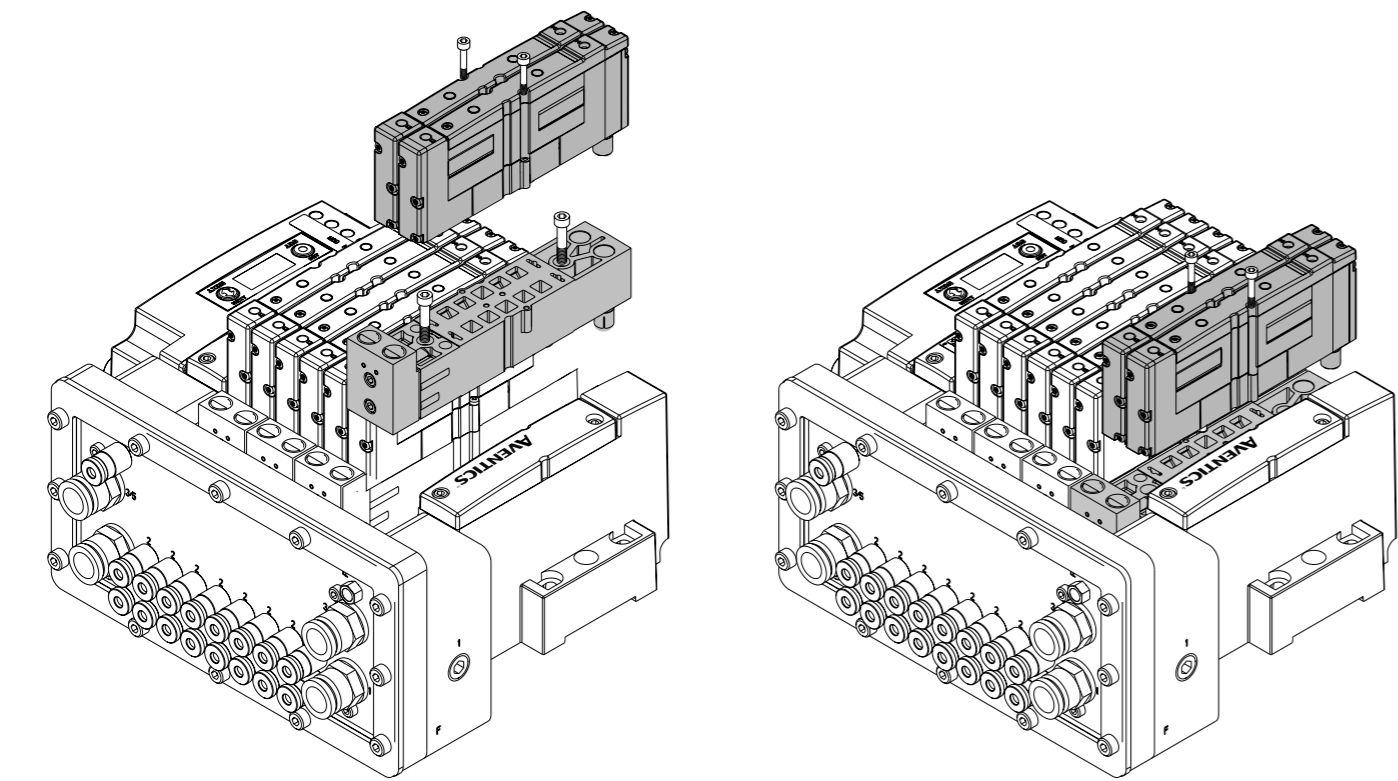
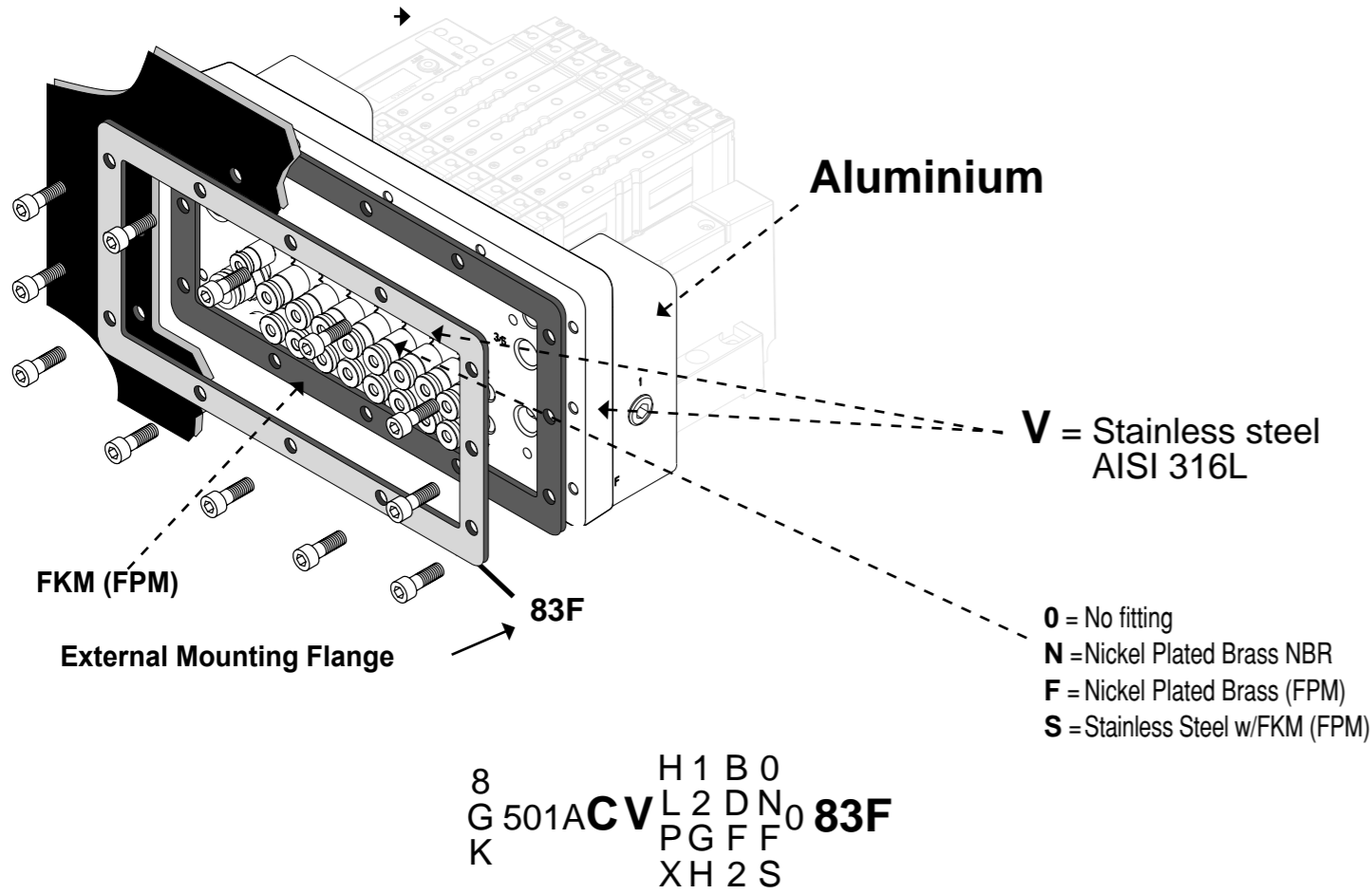
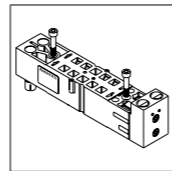

506366-001



AVENTICS™ SERIES 501 CABINET VERSIONS
Panel Mount Assembly
Version with Vertical Shut Off

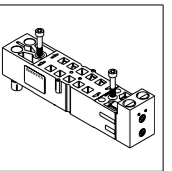

2D/3D CAD models

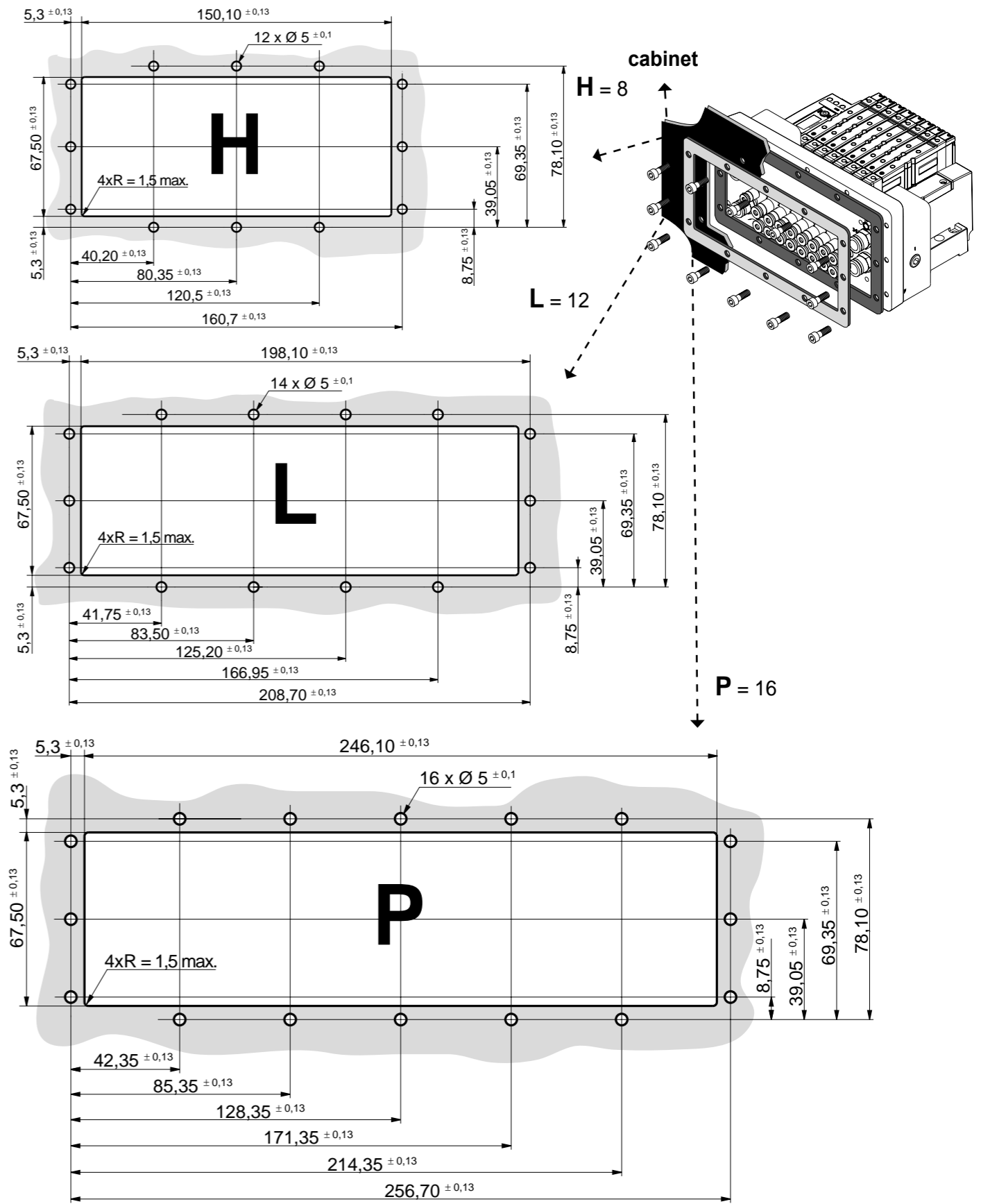

506366-001



AVENTICS™ SERIES 501 CABINET VERSIONS

Panel Mount Assembly Version with Vertical Shut Off

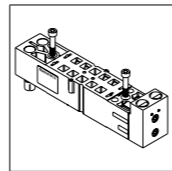

2D/3D CAD models

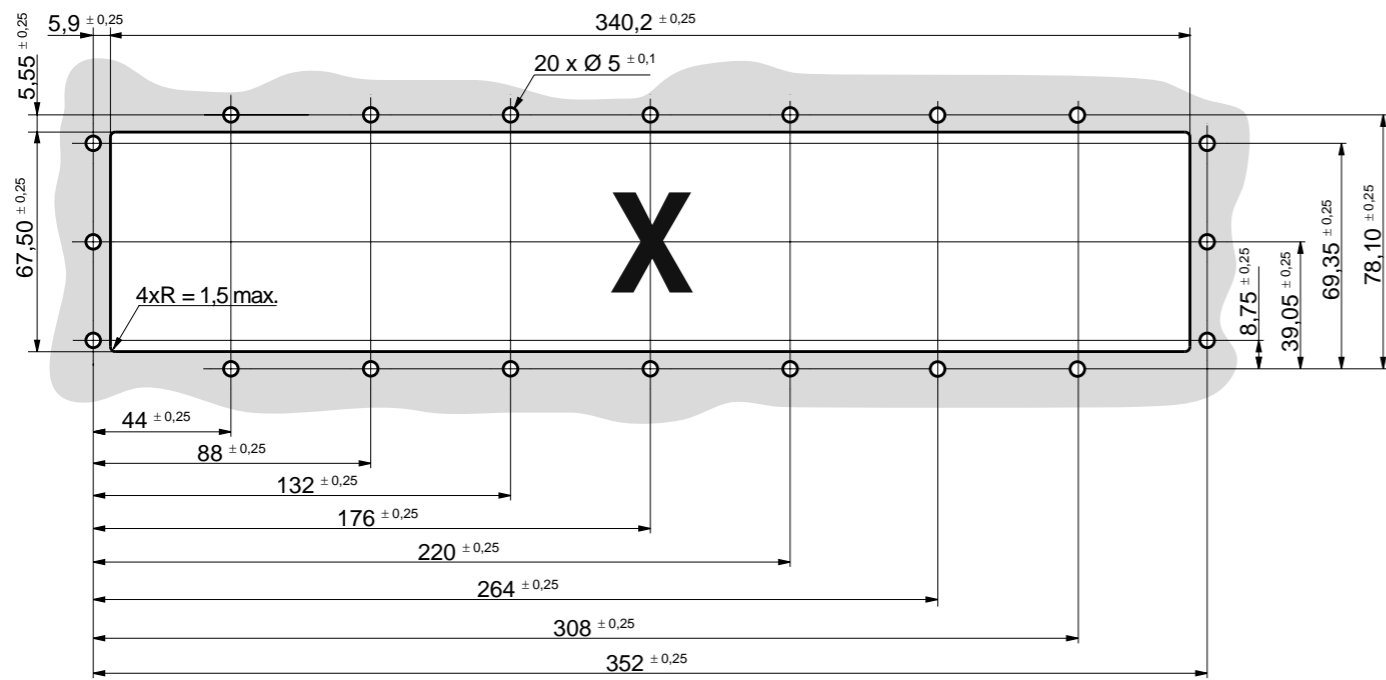
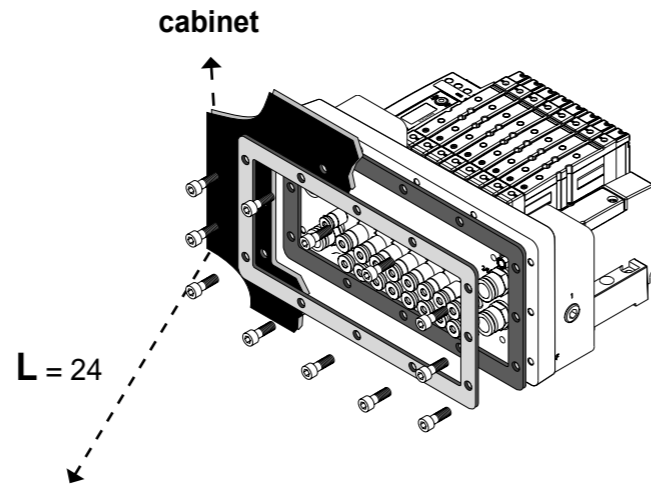

506366-001



AVENTICS™ SERIES 501 CABINET VERSIONS

Panel Mount Assembly Version with Vertical Shut Off

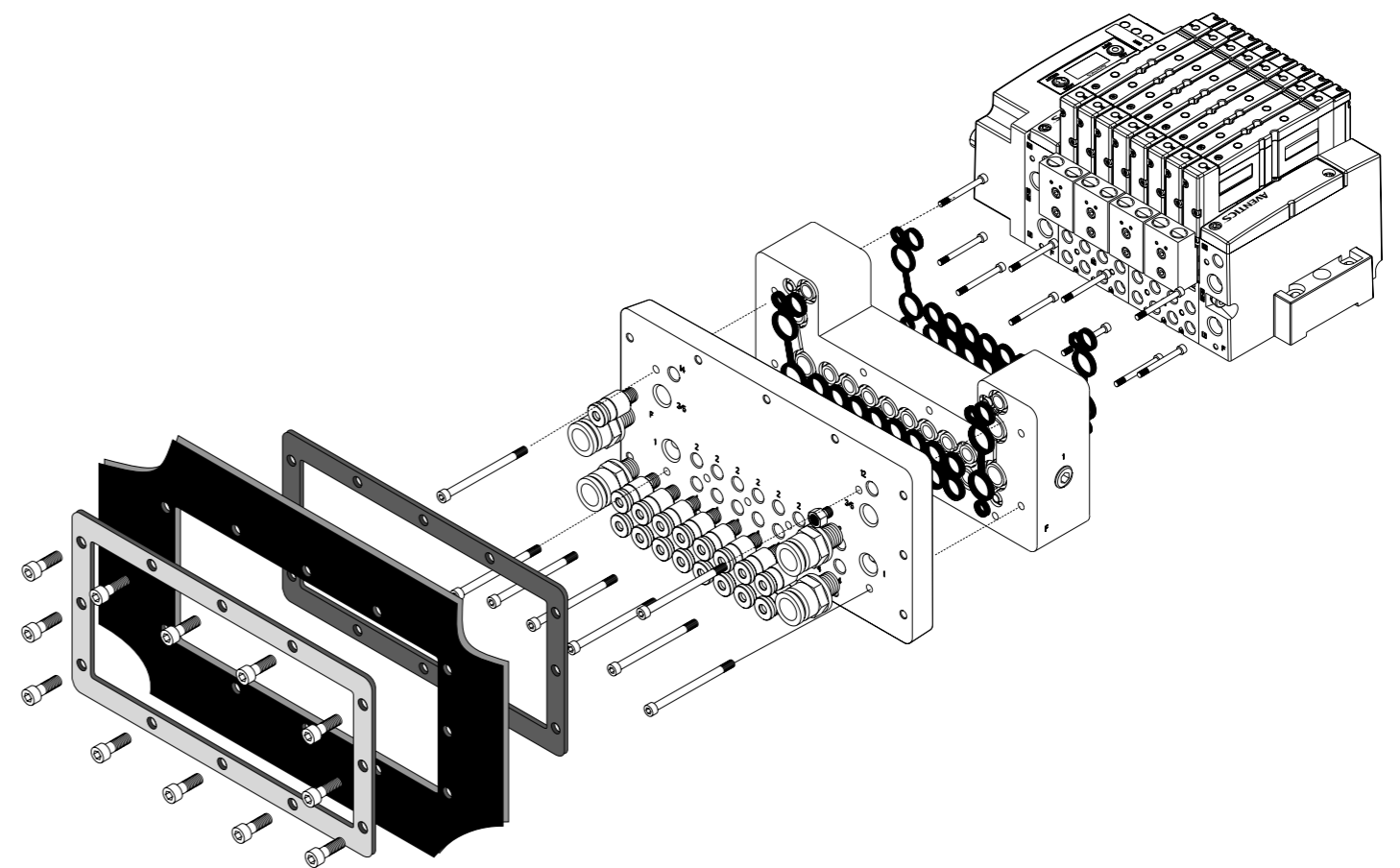
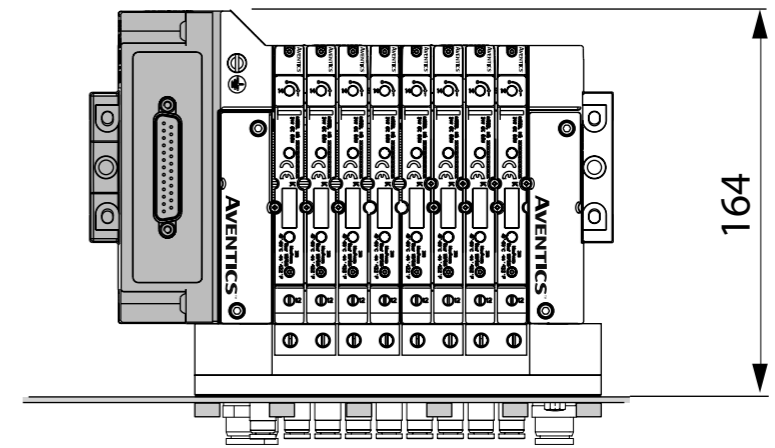
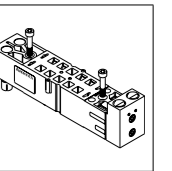

83F

506366-001



AVENTICS™ SERIES 501 CABINET VERSIONS

**Panel Mount Assembly
Version with Vertical Shut Off**

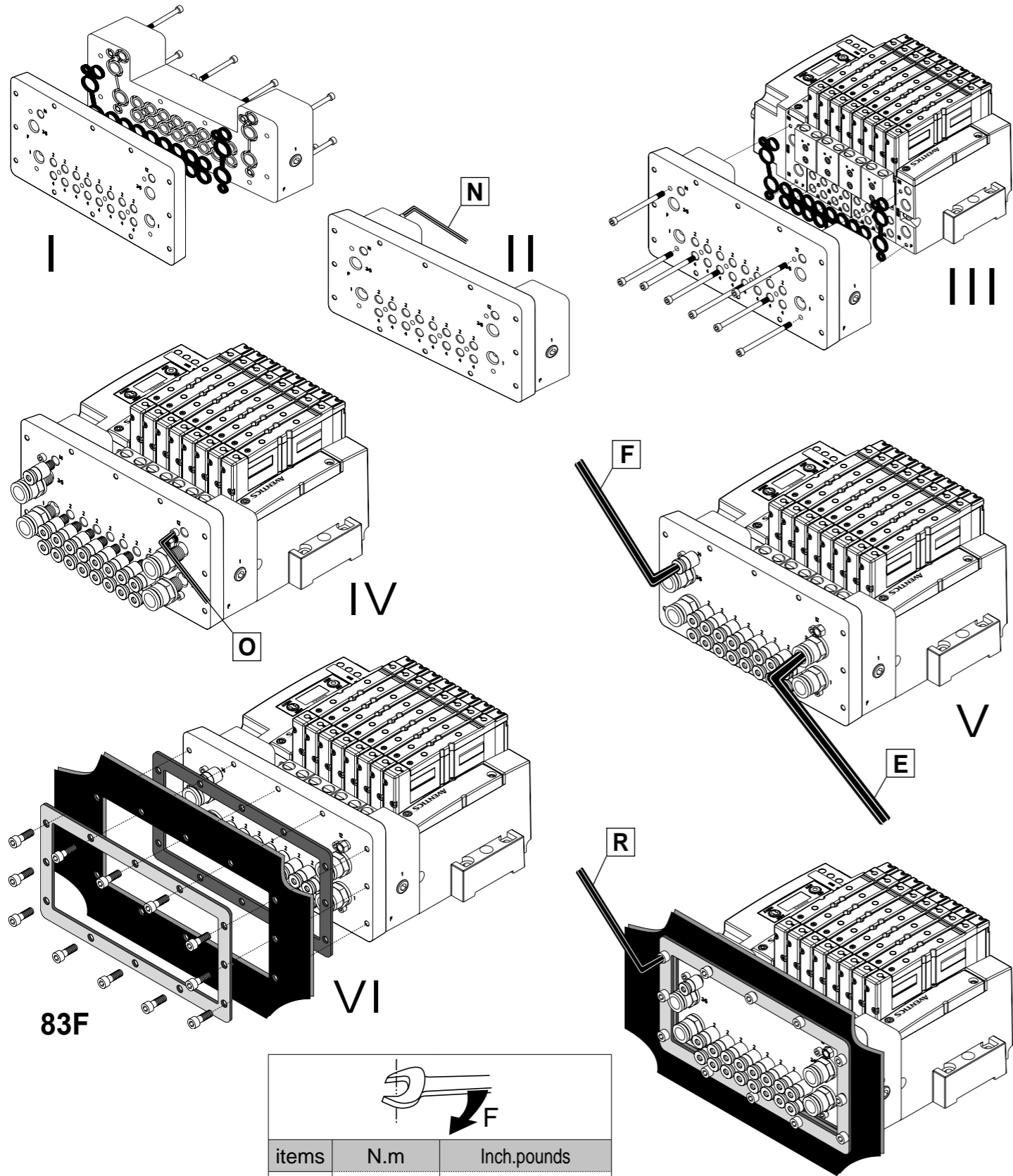
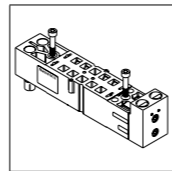

items	N.m	Inch.pounds
E	7,75 ±10%	68,6 ± 6,9
F	4,0 ±10%	35,4 ± 3,5
N	2,3 ±10%	20 ± 3
O	2,3 ±10%	20 ± 3
R	2,8 ±10%	25 ± 5

VII

506366-001



AVENTICS™ SERIES 501 CABINET VERSIONS

**Panel Mount Assembly
Version without Vertical Shut Off**

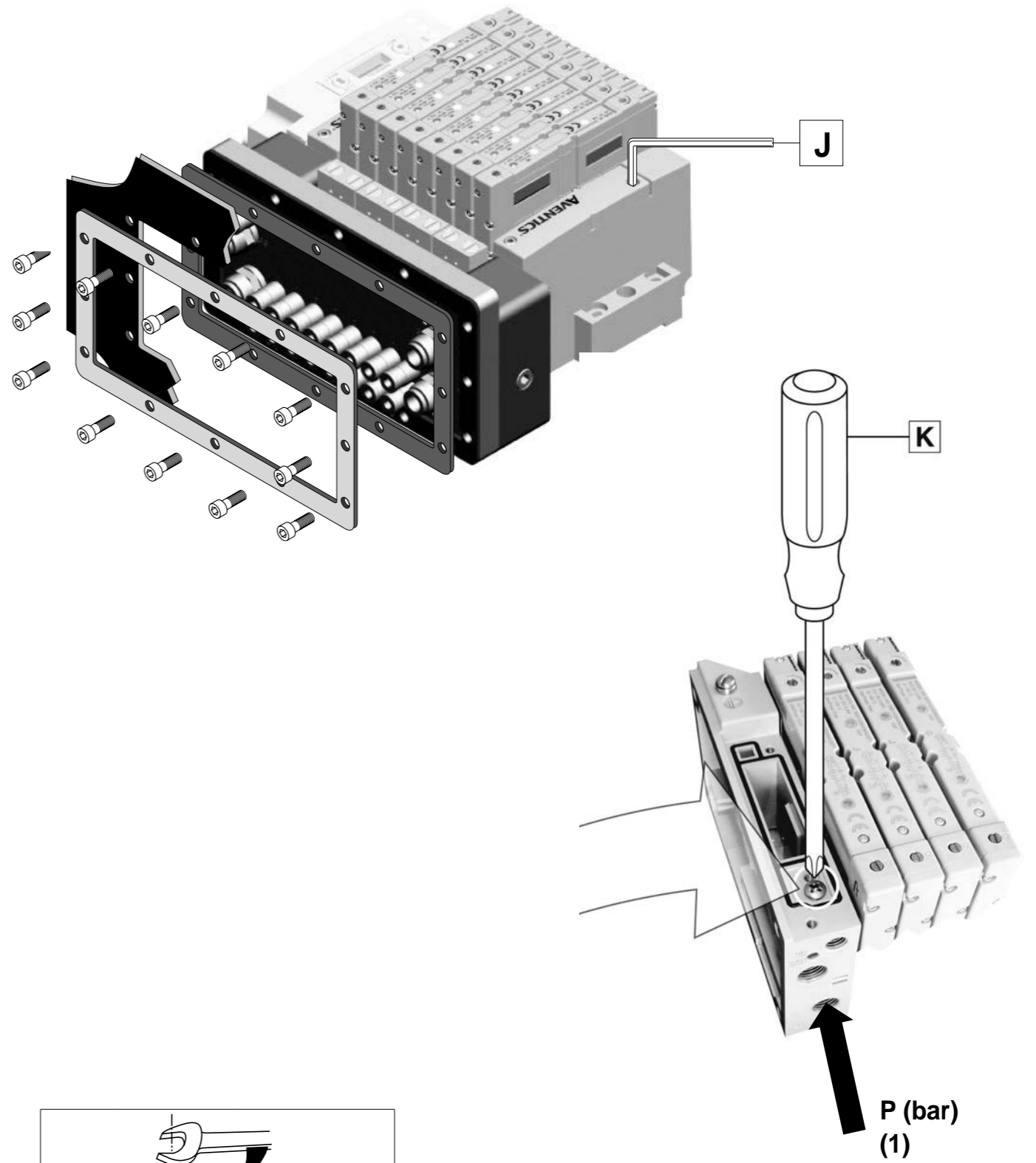
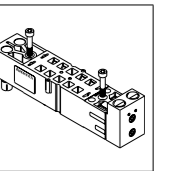

items	N.m	Inch.pounds
K	1,1 ±10%	10 ±1
J	2,4 ±10%	21 ±2.1

internal pilot supply

P (bar)
(1)

506366-001



AVENTICS™ SERIES 501 CABINET VERSIONS

Panel Mount Assembly

Version without Vertical Shut Off

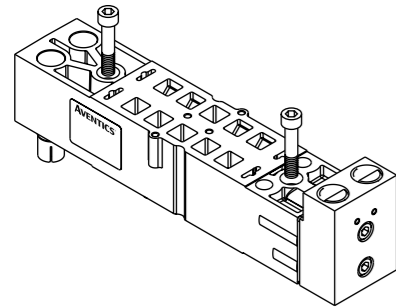
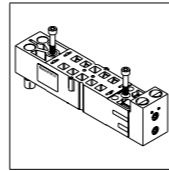

R501AY503875001

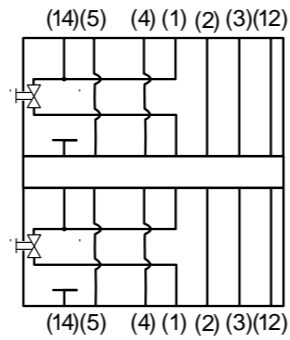

AVENTICS™ SERIES 501 CABINET VERSIONS

Accessories

Version with Vertical Shut Off

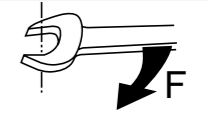
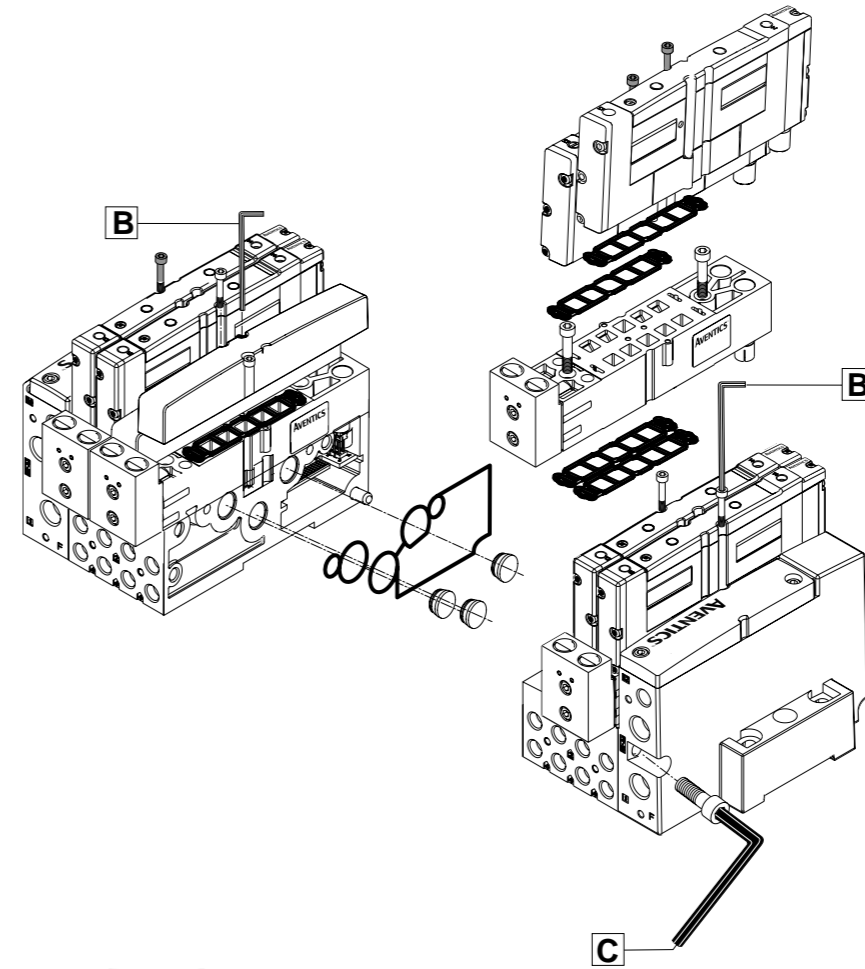
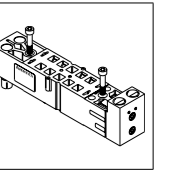

items	N.m	Inch.pounds
C	3,1 ±10%	27 ±2.7
B	0,45 ±10%	4 ±0.4



P501AB429685001

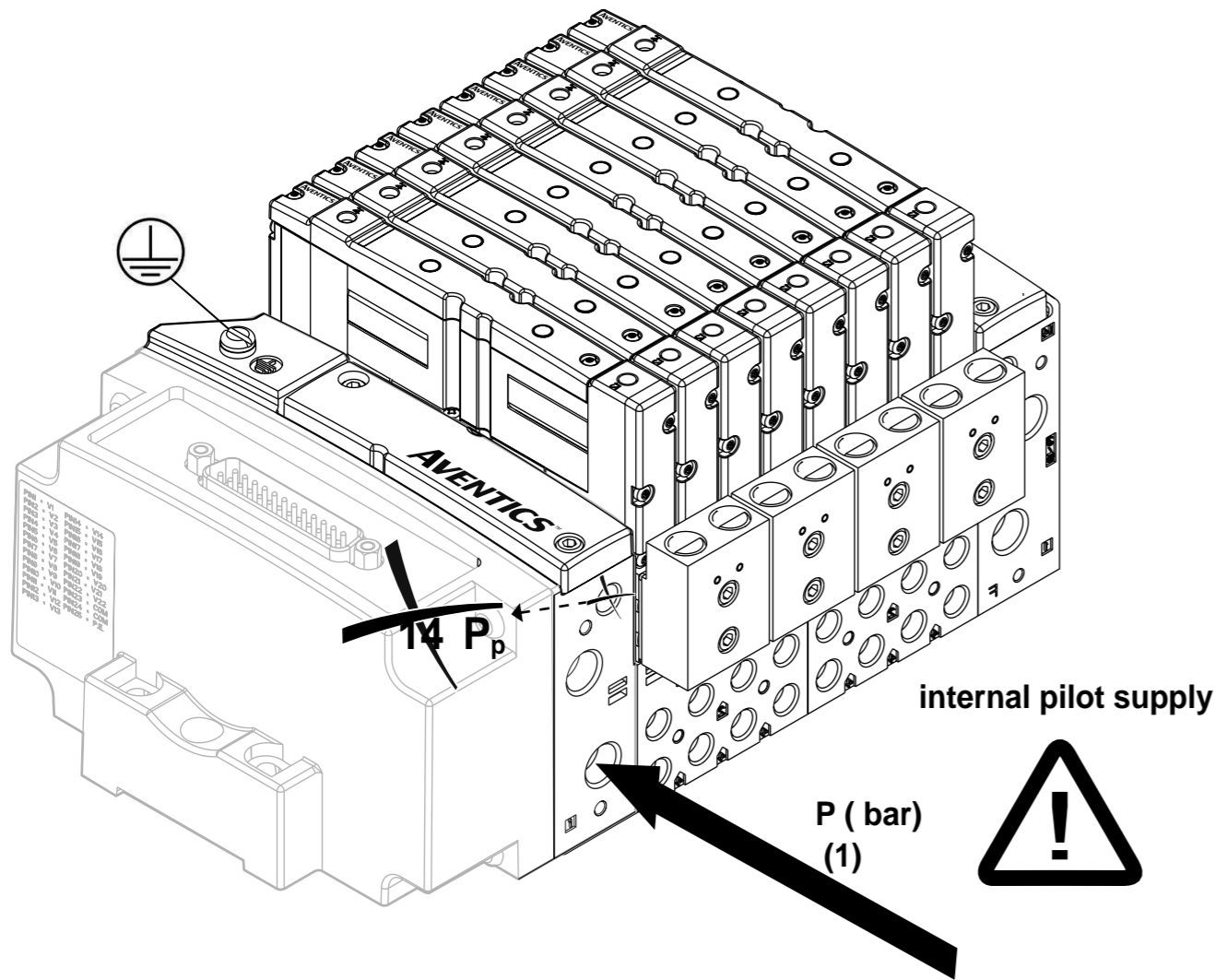
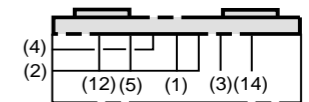

**P (bar)
(1)**



506366-001

P501AD431915001		+		•	1
P501AD431915002		+		•	3
P501AD431915003		+		•	5
P501AD431915004		+		•	1, 3
P501AD431915005		+		•	1, 5
P501AD431915006		+		•	3, 5
P501AD431915007		+		•	1, 3, 5

506366-001



AVENTICS™ SERIES 501 CABINET VERSIONS

Accessories

Version with Vertical Shut Off

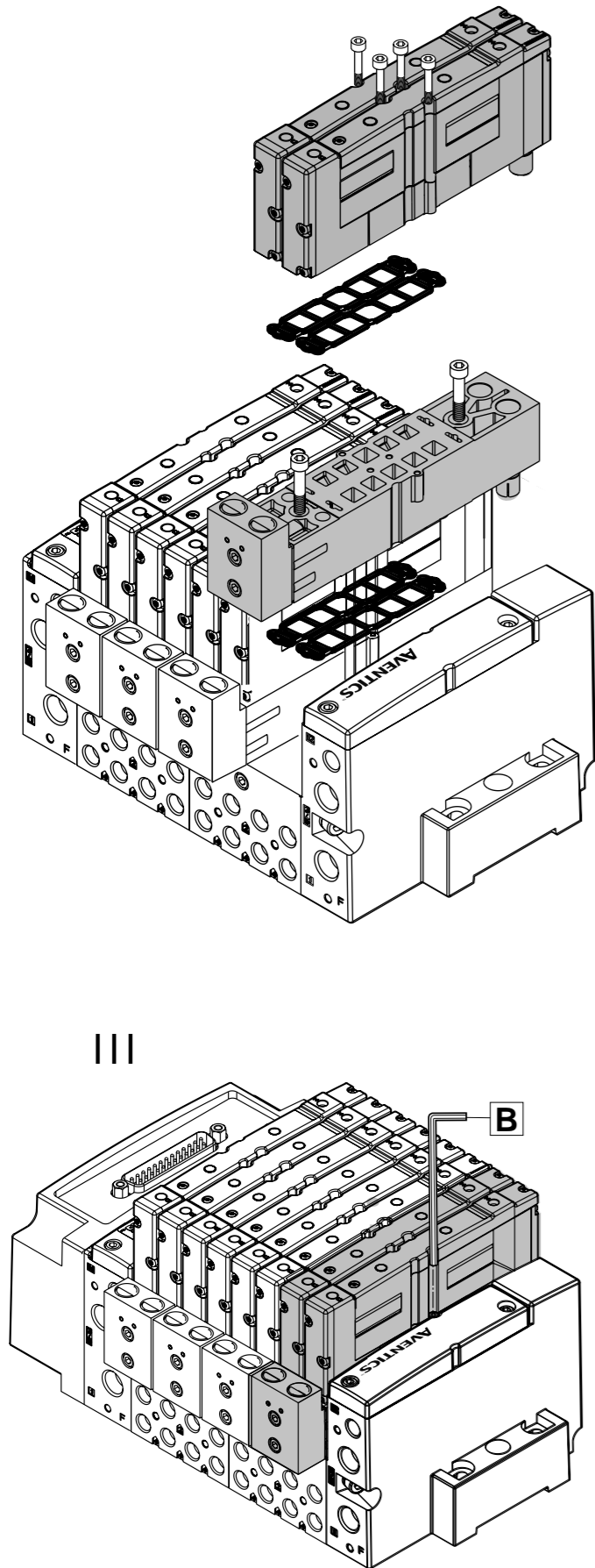
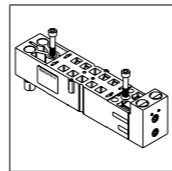

items	N.m	Inch.pounds
B	0,45 ±10%	4 ±0.4
M	1,7 ±10%	15.1 ±1.5

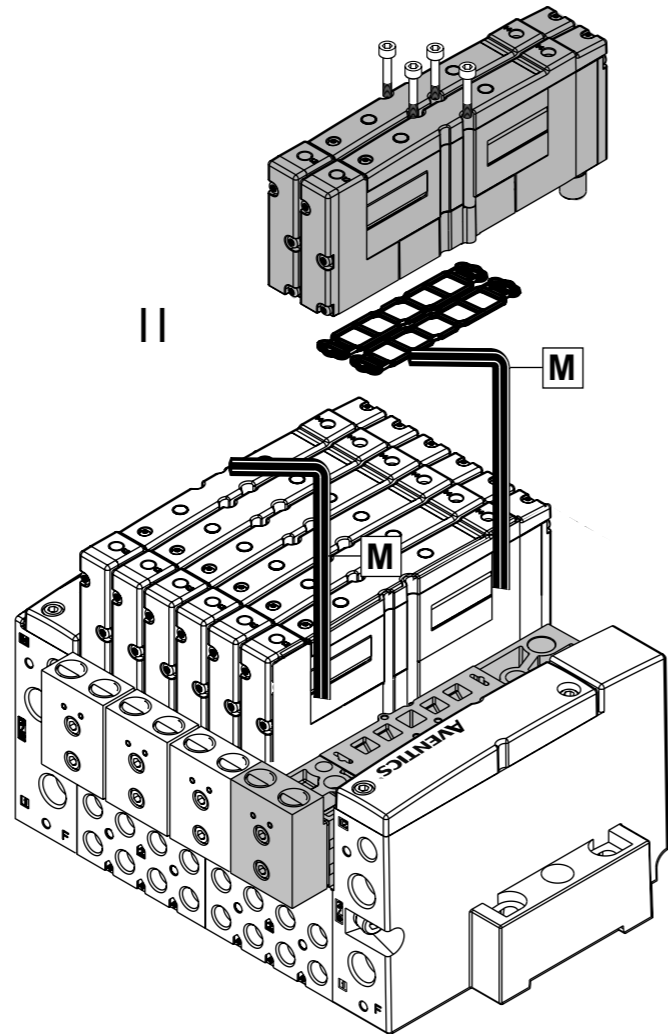

506366-001



AVENTICS™ SERIES 501 25 Pin Sub-D / 37 Pin Sub-D 1-32 Terminal Strip / 19 or 26 Pin Round Connector G3 / 580

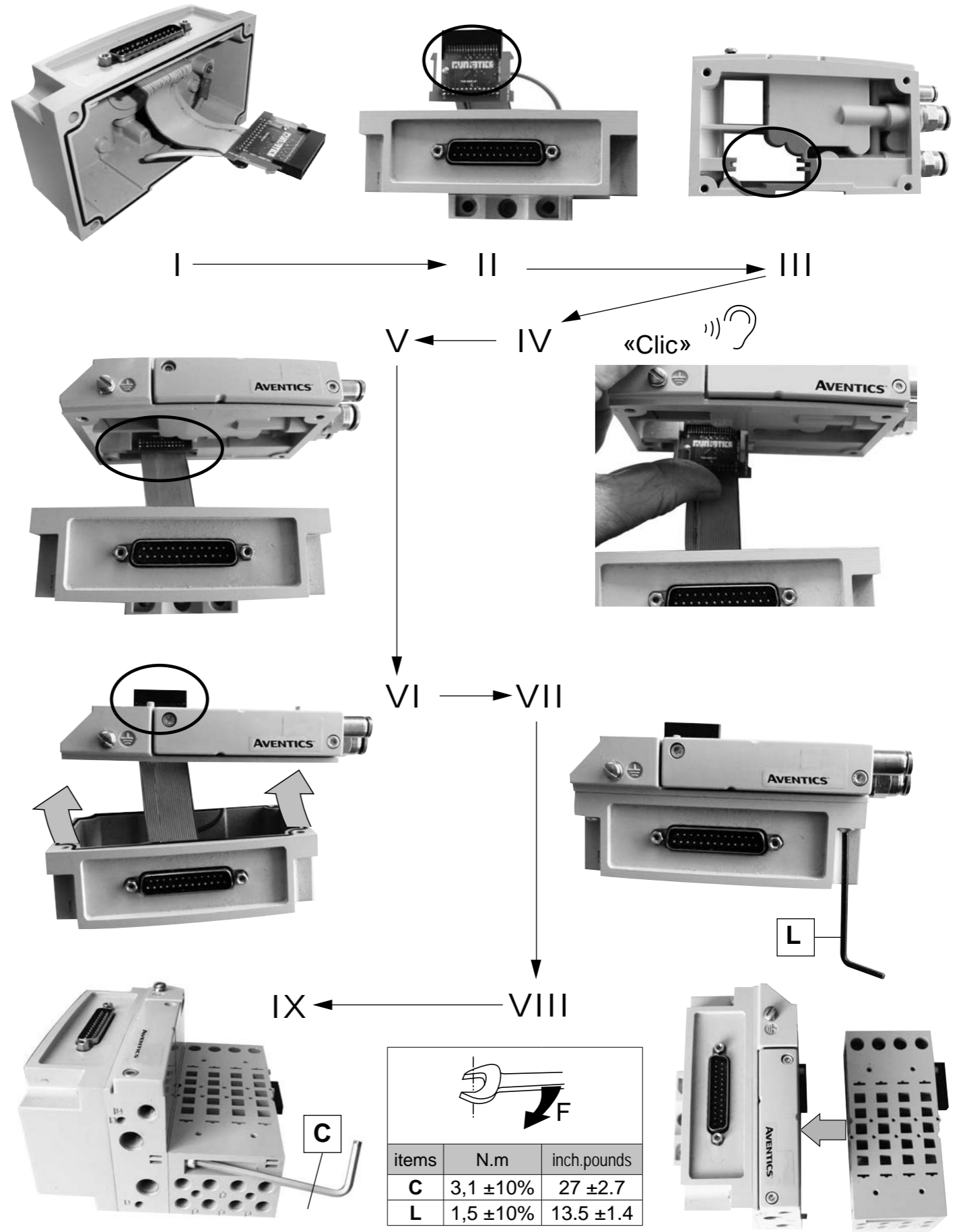





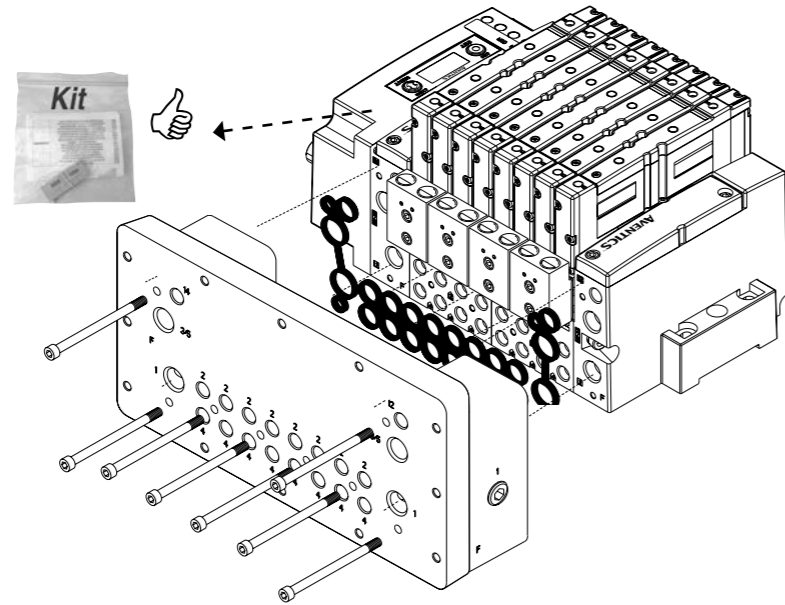
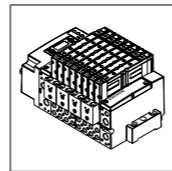

items	N.m	inch.pounds
C	3,1 ±10%	27 ±2.7
L	1,5 ±10%	13.5 ±1.4

506366-001



AVENTICS™ SERIES 501
CABINET VERSIONS
580



	DeviceNet™		EtherCAT®
	P580AEDN1010A00		P580AEEC1010A00
	PROFIBUS DP®		PROFINET®
	P580AEPT1010A00		P580AEPN1010A00
	EtherNET/IP™ DLR		SUB-BUS
	P580AEED1010A00		P580AEDS4010A00

506366-001

506366-001