

TRANSISTORIZED INVERTER FR-CV INSTRUCTION MANUAL

**POWER REGENERATION
COMMON CONVERTER**

**FR-CV-7.5K to 30K(-AT)
FR-CV-37K, 55K
FR-CV-H7.5K to H30K(-AT)
FR-CV-H37K, H55K
FR-CVL-7.5K to 55K
FR-CVL-H7.5K to H55K**

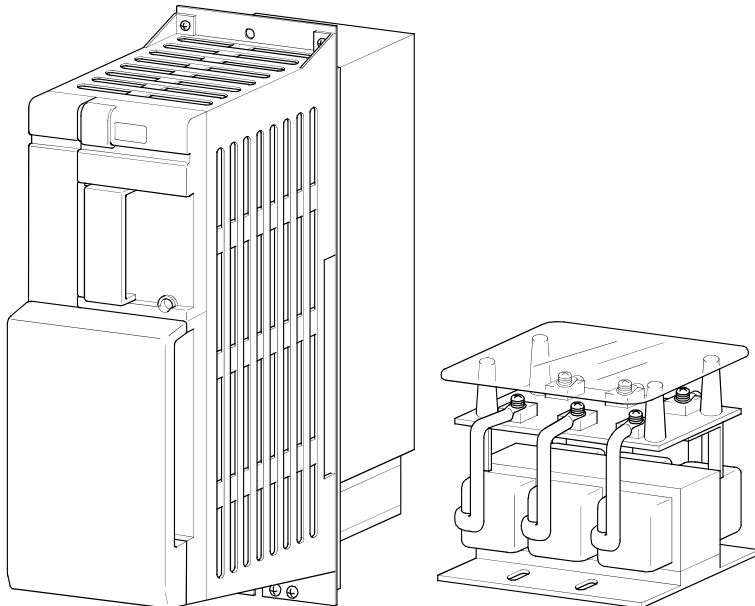

OUTLINE

1

**INSTALLATION
AND WIRING**

2

**PROTECTIVE
FUNCTIONS**

3

SPECIFICATIONS

4

Thank you for choosing this Mitsubishi transistorized inverter option unit. This instruction manual provides handling information and precautions for use of the equipment. Before using the inverter option, always read this instruction manual carefully to use the equipment to its optimum.

Please forward this instruction manual to the end user.

This instruction manual uses the International System of Units (SI). The measuring units in the yard and pound system are indicated in parentheses as reference values.

This section is specifically about safety matters

Do not attempt to install, operate, maintain or inspect the inverter until you have read through the instruction manual and appended documents carefully and can use the equipment correctly. In this instruction manual, the safety instruction levels are classified into "WARNING" and "CAUTION".

 **WARNING**

Assumes that incorrect handling may cause hazardous conditions, resulting in death or severe injury.

 **CAUTION**

Assumes that incorrect handling may cause hazardous conditions, resulting in medium or slight injury, or may cause physical damage only.

Note that even the  **CAUTION** level may lead to a serious consequence according to conditions. Please follow the instructions of both levels because they are important to personnel safety.

1. Electric Shock Prevention

 **WARNING**

- While power is on or when the inverter is running, do not open the terminal block cover. You may get an electric shock.
- Do not run the inverter with the terminal block cover removed. Otherwise, you may access the exposed high-voltage terminals or the charging part of the circuitry and get an electric shock.
- Before starting wiring or inspection, switch off power, check to make sure that the charge lamp is off, wait for at least 10 minutes after the power supply has been switched off, and check that there are no residual voltage using a tester or the like. The capacitor is charged with high voltage for some time after power off and it is dangerous.
- Earth (ground) the inverter.
- Any person who is involved in wiring or inspection of this equipment should be fully competent to do the work.
- Always install the inverter before wiring. Otherwise, you may get an electric shock or be injured.
- Perform setting dial and key operations with dry hands to prevent an electric shock.
- Do not subject the cables to scratches, excessive stress, heavy loads or pinching. Otherwise, you may get an electric shock.

2. Fire Prevention

 **CAUTION**

- Mount the power regeneration common converter unit and dedicated stand-alone reactor unit to incombustible material. Mounting it to or near combustible material can cause a fire.
- Do not connect a resistor directly to the DC terminals P/L+, N/L-. This could cause a fire.

3. Injury Prevention

 **CAUTION**

- Apply only the voltage specified in the instruction manual to each terminal to prevent damage etc.
- Ensure that the cables are connected to the correct terminals. Otherwise damage etc. may occur.
- Always make sure that polarity is correct to prevent damage etc.
- While power is on and for some time after power-off, do not touch the power regeneration common converter unit and dedicated stand-alone reactor unit as they are hot and you may get burnt.
- When changing the fan, take care not to get injured.

4. Additional Instructions

Also note the following points to prevent an accidental failure, injury, electric shock, etc.

1) Transportation and installation

CAUTION

- When carrying products, use correct lifting gear to prevent injury.
- Do not stack the inverter option boxes higher than the number recommended.
- Ensure that installation position and material can withstand the weight of the inverter.
- Do not operate if the power regeneration common converter is damaged or has parts missing.
- When carrying the inverter option, do not hold it by the terminal block cover or setting dial; it may fall off or fail.
- Do not stand or rest heavy objects on the inverter option.
- Check the inverter option mounting orientation is correct.
- Prevent screws, wire fragments, other conductive bodies, oil or other flammable substances from entering the power regeneration common converter.
- Do not drop the power regeneration common converter, or subject it to impact.
- Use the inverter option under the following environmental conditions. Using it outside the operating range can cause the power regeneration common converter to become faulty.

Environment	Ambient temperature	-10°C to +50°C (14°F to 122°F) (non-freezing)
	Ambient humidity	90%RH or less (non-condensing)
	Storage temperature	-20°C to +65°C* (-4°F to 149°F)
	Ambience	Indoors (free from corrosive gas, flammable gas, oil mist, dust and dirt)
	Altitude, vibration	Maximum 1000m (3280.80feet) above sea level for standard operation. After that derate by 3% for every extra 500m (1640.40feet) up to 2500m (8202.00feet) (91%). 5.9m/s ² or less

*Temperature applicable for a short time, e.g. in transit.

2) Operation

WARNING

- Do not modify the equipment.
- Do not perform parts removal which is not instructed in this manual. Doing so may lead to fault or damage of the product.

3) Maintenance, inspection and parts replacement

CAUTION

- Do not carry out a megger (insulation resistance) test on the control circuit of the power regeneration common converter unit.

4) Emergency stop

CAUTION

- When the breaker on the power regeneration common converter input side trips, check for the wiring fault (short circuit), damage to internal parts of the power regeneration common converter, etc. Identify the cause of the trip, then remove the cause and power on the breaker.

5) Disposing of the inverter

CAUTION

- Treat as industrial waste

6) General instructions

Many of the diagrams and drawings in this instruction manual show the inverter without a cover, or partially open. Never operate the inverter in this like. Always replace the cover and follow this instruction manual when operating the inverter.

CONTENTS

1	OUTLINE	1
1.1	Pre-Operation Information	2
1.1.1	Precautions for operation	2
1.2	Basic Configuration	4
1.2.1	Basic configuration	4
1.3	Structure	5
1.3.1	Appearance and structure	5
1.3.2	Removal and reinstallation	6
1.3.3	Structure of the power regeneration common converter	8
2	INSTALLATION AND WIRING	9
2.1	Installation	10
2.1.1	Instructions for installation	10
2.2	Wiring	12
2.2.1	Terminal connection diagram	12
2.2.2	Wiring of the main circuit	14
2.2.3	Wiring of the control circuit	21
2.2.4	Design information	22
2.3	Operation	23
2.3.1	Pre-operation checks	23
2.3.2	Power-on and operation	23
2.4	Other wiring	24
2.4.1	Power harmonics	24
2.4.2	Noise types and reduction techniques	25
2.4.3	Peripheral devices	26
2.4.4	Instructions for UL and cUL	28
3	PROTECTIVE FUNCTIONS	29
3.1	Errors (Alarms)	30
3.1.1	Error (alarm) definitions	30
3.1.2	Alarm symptoms and check points	31
3.2	Precautions for Maintenance and Inspection	32
3.2.1	Precautions for maintenance and inspection	32
3.2.2	Check items	32
3.2.3	Periodic inspection	32
3.2.4	Insulation resistance test using megger	33
3.2.5	Pressure test	33
3.2.6	Daily and Periodic Inspection	34
3.2.7	Replacement of parts	36
3.2.8	Measurement of main circuit voltages, currents and power	40

4.1	Standard Specifications	44
4.1.1	Model specifications	44
4.1.2	Internal block diagram	47
4.1.3	Outline drawings.....	48

CHAPTER 1

OUTLINE

This chapter gives information on the basic "outline" of this product.

Always read the instructions in this chapter before using the equipment.

1.1	Pre-Operation Information	2
1.2	Basic Configuration.....	4
1.3	Structure	5

1.1 Pre-Operation Information

1.1.1 Precautions for operation

Incorrect handling might cause the inverter option to operate improperly, its life to be reduced considerably, or at the worst, the inverter option to be damaged. Handle the power regeneration common converter properly in accordance with the information in each section as well as the precautions and instructions of this manual to use it correctly.

This manual is written for the power regeneration common converter FR-CV.

For handling information on the inverter, stand-alone options, etc., refer to the corresponding manuals.

(1) Unpacking and product check

Unpack the power regeneration common converter and check the capacity plate on the front cover and the rating plate on the inverter side face to ensure that the product agrees with your order and the inverter is intact.

1) Definition of the power regeneration common converter type

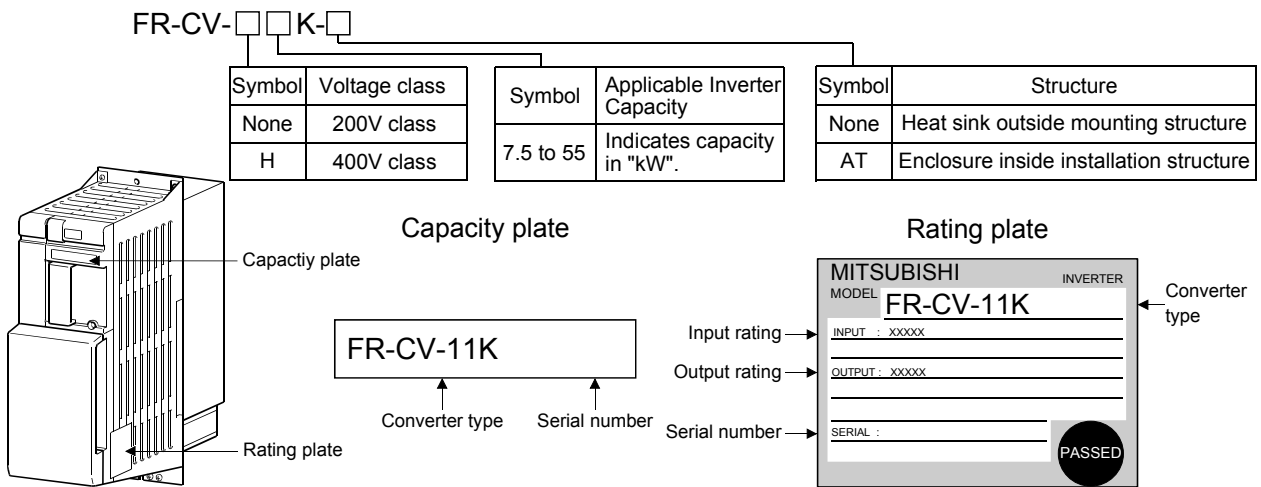

2) The power regeneration common converter accessory Instruction manual

3) Definition of the dedicated stand-alone reactor Remember to prepare the dedicated stand-alone reactor as it must be installed.

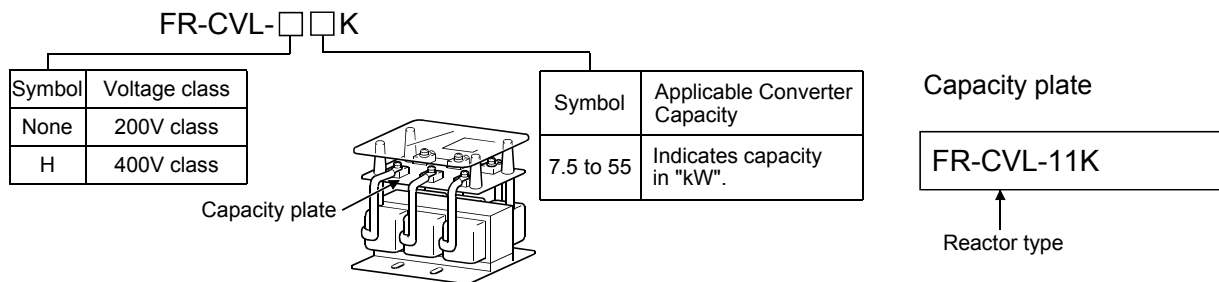

If you have found any discrepancy, damage, etc., please contact your sales representative.

(2) Confirmation of the peripheral device types

The dedicated stand-alone reactor must be installed.

Power regeneration common converter	Dedicated stand-alone reactor (required)
FR-CV-7.5K(-AT)	FR-CVL-7.5K
FR-CV-11K(-AT)	FR-CVL-11K
FR-CV-15K(-AT)	FR-CVL-15K
FR-CV-22K(-AT)	FR-CVL-22K
FR-CV-30K(-AT)	FR-CVL-30K
FR-CV-37K	FR-CVL-37K
FR-CV-55K	FR-CVL-55K

Note: 400Vclass devices have capacity numbers preceded by H in their type codes.

(3) Installation

To operate the power regeneration common converter with high performance for a long time, install the inverter in a proper place, in the correct direction, and with proper clearances. (Refer to page 10.)

(4) Wiring

Connect the power supply, inverter and control signals to the terminal block. Note that incorrect connection may damage the power regeneration common converter , inverter and peripheral devices. (Refer to page 10.)

1.2 Basic Configuration

1.2.1 Basic configuration

The following devices are required to operate the power regeneration common converter. Proper peripheral devices must be selected and correct connections made to ensure proper operation. Incorrect system configuration and connections can cause the inverter to operate improperly, its life to be reduced considerably, and in the worst case, the inverter to be damaged.

Please handle the product properly in accordance with the information in each section as well as the precautions and instructions of this manual. (For connections of the peripheral devices, refer to the corresponding manuals.)

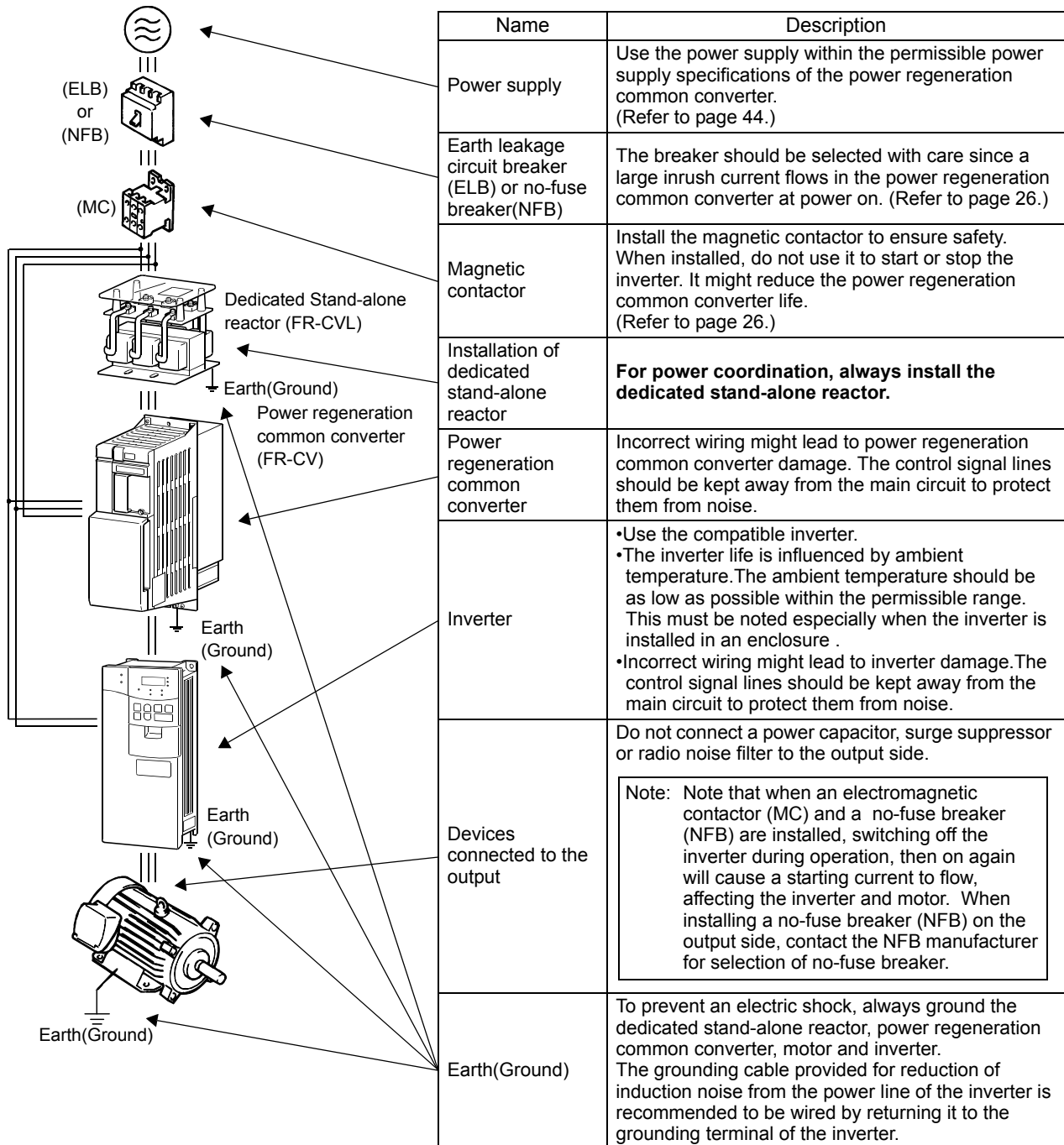

Note: If connected to the inverter, the power factor improving DC reactor (FR-BEL) does not produce an effect on power factor improvement. In addition, do not use the power factor improving AC reactor (FR-BAL) since using it may degrade the power regeneration function.

1.3 Structure

1.3.1 Appearance and structure

FR-CV-7.5K to 30K (-AT), FR-CV-H7.5K to H30K (-AT)

(1) Front view

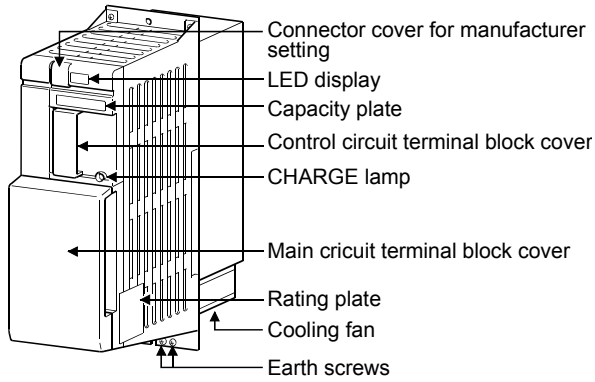

(2) Without front cover

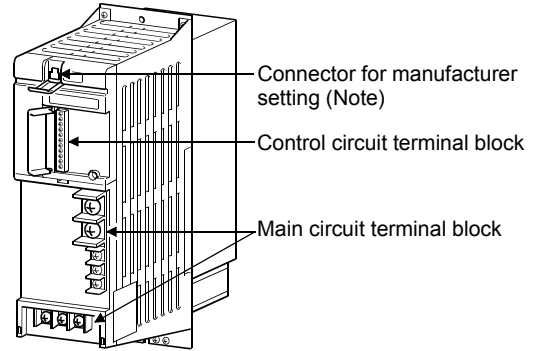

FR-CV-37K/55K, FR-CV-H37K/H55K

(1) Front view

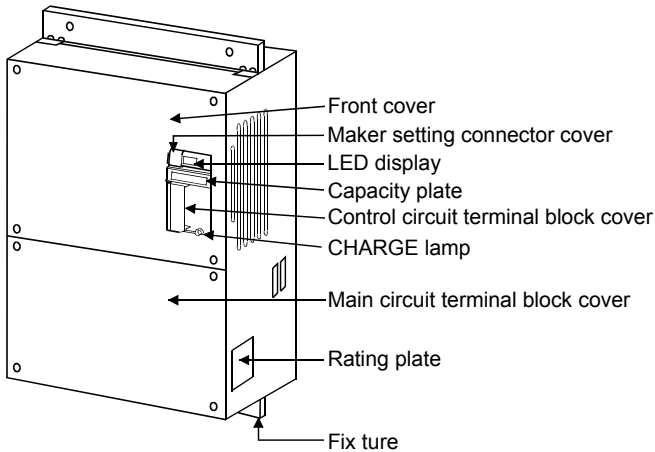

(2) Without front cover

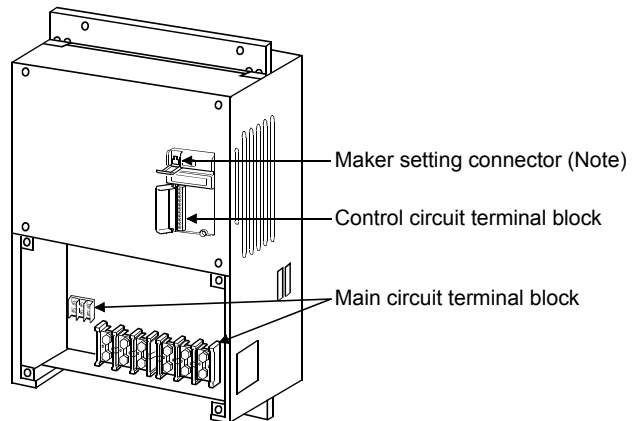

Note: Keep the connector for manufacturer setting open.

1.3.2 Removal and reinstallation

(1) Main circuit terminal block cover

FR-CV-7.5K to 30K (-AT), FR-CV-H7.5K to H30K(-AT)

●Removal

- 1) Hold both ends of the cover bottom and pull it toward you.
- 2) When the bottom of the cover has come off, hold both ends of the cover top and pull it toward you.

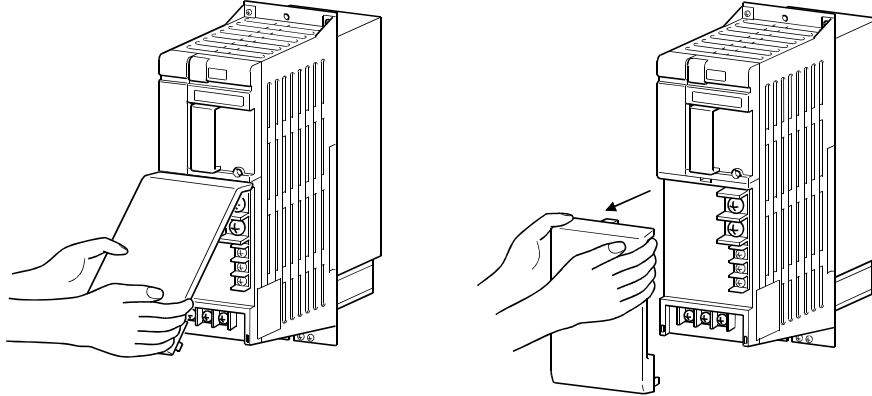

●Reinstallation

- 1) Insert the catch at the cover top into the socket in the unit.
- 2) Using the part of the catch as a support, securely press the catches at both ends of the cover bottom to the unit.

FR-CV-37K/55K, FR-CV-H37K/H55K

●Removal

- 1) Remove the installation screws at the top of the main circuit terminal block cover.

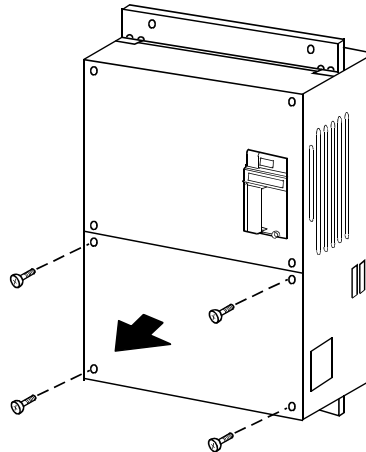

●Reinstallation

- 1) Fix the main circuit terminal block cover with the installation screws.

(2) Control circuit terminal block cover**●Opening**

- 1) Hold the right end of the cover and pull it toward you.
- 2) The cover opens, with the left-hand side of the cover acting as a support.

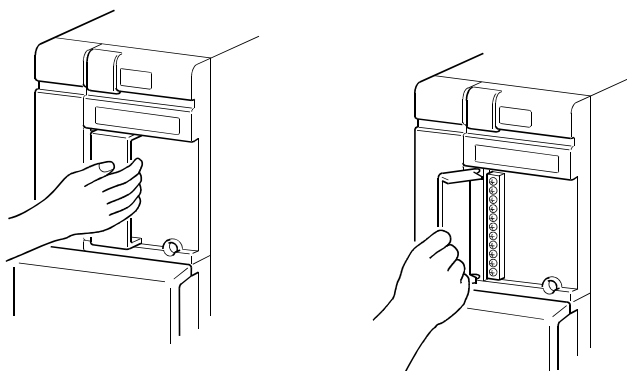
**●Closing**

- 1) Securely press the right end of the cover against the unit.

Note: Make sure that the cover has been fitted securely.

1.3.3 Structure of the power regeneration common converter

The power regeneration common converter is available in two types: a heat sink outside mounting structure model and an enclosure inside installation structure model.

(1) Heat sink outside mounting structure model (FR-CV-7.5K to 55K, FR-CV-H7.5 to H55K)

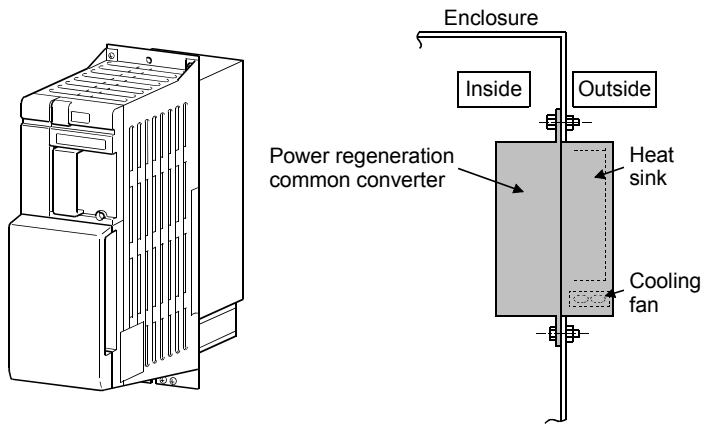

The FR-CV-37K, 55K and FR-CV-H37K, H55K can be used either as a heat sink outside mounting structure model or an enclosure inside installation structure model by changing its mounting foot position. It is shipped from the factory as a heat sink outside mounting structure model. Change the mounting foot position as shown below for installation.

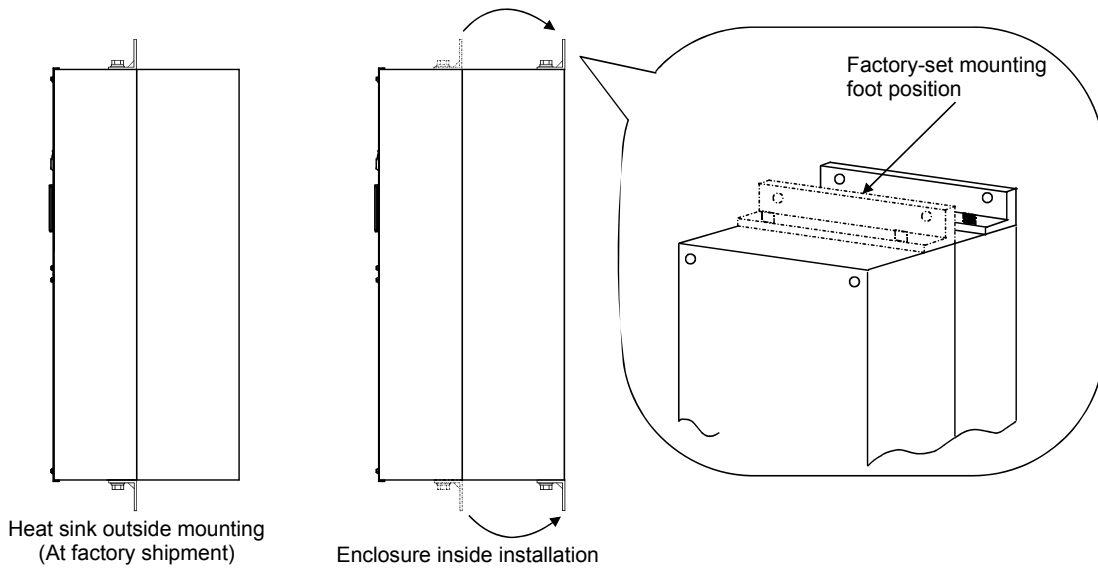

(2) Enclosure inside installation structure model (FR-CV-7.5K to 30K-AT, FR-CV-H7.5K to H30K-AT)

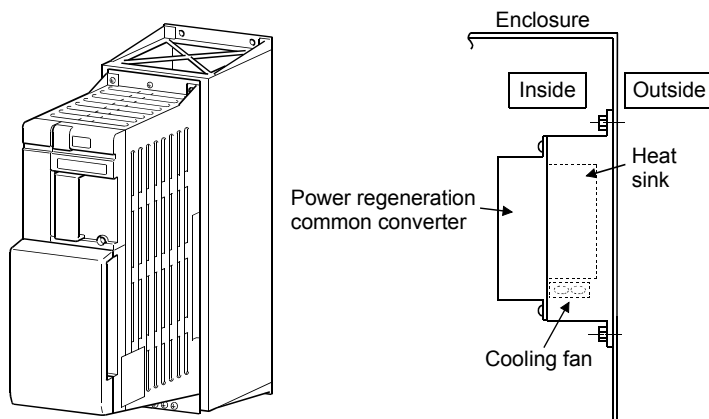

CHAPTER 2

INSTALLATION AND WIRING

This chapter gives information on the basic "Installation and wiring" of this product.
Always read the instructions in this chapter before using the equipment.

- 2.1 Installation 10
- 2.2 Wiring..... 12
- 2.3 Operation 23
- 2.4 Other wiring..... 24



2.1 Installation

2.1.1 Instructions for installation

- 1) Handle the unit carefully.
The power regeneration common converter uses plastic parts. Handle it gently to protect it from damage. Also, hold the unit with even strength and do not apply too much strength to the terminal block cover alone.
- 2) Install the inverter in a place where it is immune to vibration. (5.9 m/s² or less)
Also note the cart, press, etc.
- 3) Note on ambient temperature
The power regeneration common converter life is under great influence of ambient temperature. Exercise care so that the ambient temperatures of the installation place do not fall out of the permissible range (-10°C to +50°C (14°F to 120°F)). Make sure that the ambient temperatures are within the permissible range at the measurement positions given in 3) on the next page. It is important to check that not only the ambient temperatures of the power regeneration common converter but also those of the inverter contained in the same enclosure fall within the permissible range.
- 4) Notes on installation surface
The power regeneration common converter will be very hot (maximum about 150°C (302°F)).
The power regeneration common converter (heat sink outside mounting structure model) can be reduced in the enclosure inside temperature by mounting its heat sink outside the enclosure. Cut the mounting area according to the panel cutting dimensions. Since the cooling section located outside the enclosure has a cooling fan, do not use the equipment in the environment that has water drops, oil mists, dust particles, etc. For installation in an enclosure, use the enclosure inside installation structure model of the power regeneration common converter and install it on an incombustible (e.g. metal) mounting surface.
Also leave sufficient clearances around the inverter.
- 5) Avoid high temperature and high humidity.
Avoid direct sunlight and places of high temperature and high humidity.
- 6) Avoid places where the inverter option is exposed to oil mist, flammable gases, fluff, dust, dirt etc.
Install the inverter option in a clean place or inside a "totally enclosed" panel which does not accept any suspended matter.
- 7) Note the cooling method when the power regeneration common converter and inverter is installed in an enclosure.
When two or more power regeneration common converters and inverters are installed or a ventilation fan is mounted in an enclosure, the inverters and ventilation fan must be installed in proper positions with extreme care taken to keep the ambient temperatures of the power regeneration common converters and inverters below the permissible value. If they are installed in improper positions, the ambient temperatures of the power regeneration common converters and inverters will rise and ventilation effect will be reduced.
- 8) Install the power regeneration common converter and inverter securely in the vertical direction with screws or bolts.
- 9) Install the dedicated stand-alone reactor (FR-CVL) on horizontal plane. Failure to observe this may lead to damage of the reactor.

3) Note on ambient temperature

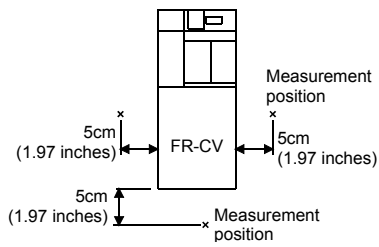

4) Clearances around the inverter

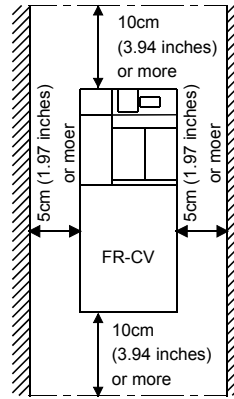

Clearances required to change the cooling fan of the enclosure inside installation structure model (-AT). (Refer to page 36 for fan replacement.)

7) For installation in an enclosure

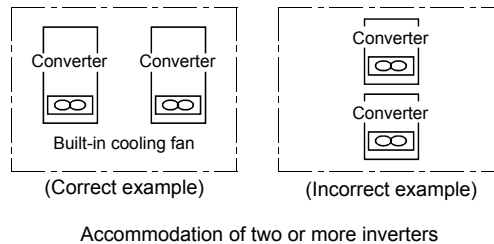
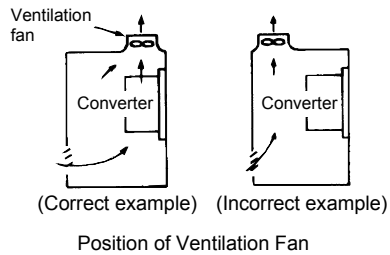

8) Vertical mounting
Power regeneration common converter

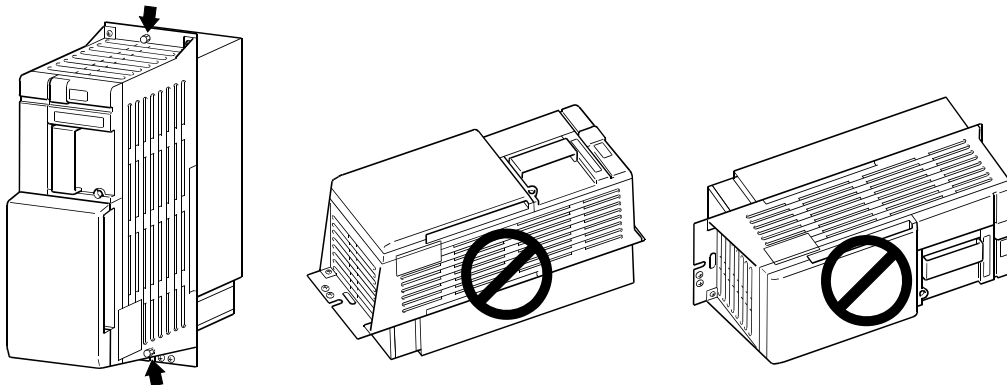

9) Horizontal plane installation
Dedicated stand-alone reactor

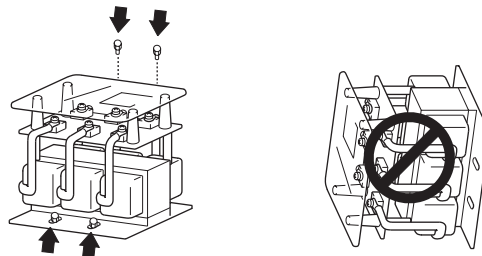

2.2 Wiring

2.2.1 Terminal connection diagram

- ⊙ Main circuit terminal
- Control circuit input terminal
- Control circuit output terminal

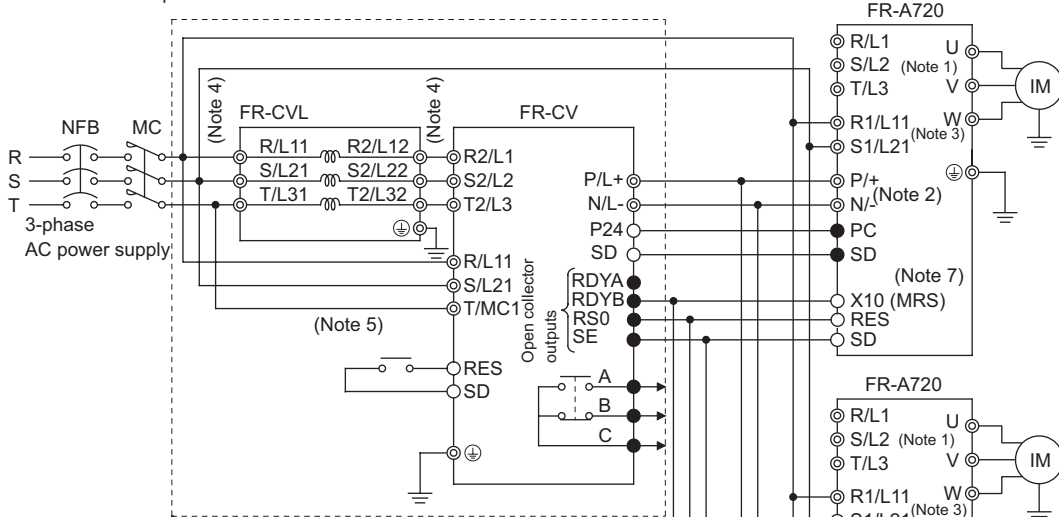

- Note : 1. Never connect a power supply to the inverter terminals R, S, T. Such a connection, even if accidental, will damage the inverter and power regeneration common converter.
2. Match the polarities of the P and N terminals by connecting terminal P of the inverter to terminal P of the power regeneration common converter and terminal N of the inverter to terminal N of the power regeneration common converter as shown in the connection example. Incorrect matching of the polarities of the P and N terminals will result in damage to the inverter.
- Do not remove a jumper across terminal P/+ and P1.
3. For the FR-A700, F700, A500, F500 and V500 series, remove the jumpers across terminals R-R1 and S-S1, and connect power supply to terminals R1, S1 for the control circuit. For the FR-E700, D700, E500, S500, C500 and F500J series, the inverter does not have terminals R1, S1. So you do not need to make this connection.
4. When wiring the dedicated stand-alone reactor and power regeneration common converter as well as when wiring the power supply and terminals R/L11, S/L21, T/MC1, strictly observe the wiring order as shown in the connection example (match phase sequence of the power supply). A wrong connection will damage the power regeneration common converter.
- Do not insert an MCCB nor MC. The power regeneration common converter functions abnormally.
5. Make sure terminals R/L11, S/L21, T/MC1 are connected to the power supply. Running the inverter without connecting these terminals will damage the power regeneration common converter.
6. Since power to the inverter is supplied by terminals P and N, set Pr.30 to 2 (for use with a high power factor converter, power regeneration common converter) for the FR-A700, F700, A500, F500 and V500 series. This setting disables the built-in brake resistor.
7. For the FR-A700, F700, E700, D700, A500, F500 and V500 series inverter, assign the X10 signal to any of input terminals to use the inverter.
8. You can connect up to six inverters to one power regeneration common converter.
9. Use sink logic (factory setting) when the FR-CV is connected. The FR-CV cannot be connected when source logic is selected.

⚠ CAUTION

⚠ Be sure to connect terminal RDY of the FR-CV to the X10 or MRS signal assigned terminal of the inverter, and connect terminal SE of the FR-CV to terminal SD of the inverter. Without proper connecting, FR-CV will be damaged.

(1) Description of main circuit terminals

Symbol	Terminal Name	Description
R2/L1, S2/L2, T2/L3	AC power input	Connect to the dedicated stand-alone reactor terminals R2/L12, S2/L22, T2/L32.
P/L+, N/L-	DC power output	Connect to the inverter terminals P, N, and keep the inverter terminals R, S, T open. For the FR-A700, F700, A500, F500 or V500 series, set 2 (for use of high power factor converter, power regeneration common converter) in Pr.30.
R/L11, S/L21, T/L31	Power supply phase detection	Terminals for power supply phase, power voltage detection and control power input. Connect to the dedicated stand-alone reactor terminals R/L11, S/L21, T/L31. Running the inverter without connecting these terminals will damage the power regeneration common converter.
	Ground	Securely connect to the earth.

(2) Description of control circuit terminals

Type	Symbol	Terminal Name	Description
Input signals Power input, contact	P24	24VDC input	Used to input 24VDC power for alarm output relay drive and reset drive signal drive. Connect to the inverter terminal PC. When you do not use the inverter terminal PC, prepare a 24VDC power supply. Permissible input voltage fluctuation: 22V to 26VDC
	RES	Reset	Used to reset the activated protective circuit. Turn the terminals RES-SD on for longer than 0.1 seconds, then turn them off.
	SD	24VDC power common Contact input common	Connect the common of the 24VDC power supply. Shorting the terminal RES and this terminal inputs the reset signal.
Output signals Open collector	RDYA	Ready output	Outputs a signal when the power regeneration common converter is ready to operate. This output has opposite logic to RDYB. Permissible load 24V 0.1ADC
	RDYB	Inverter operation enable	Outputs a signal when the power regeneration common converter is faulty or the reset signal is input. Connect to the X10 (MRS) signal of the inverter. This output has opposite logic to RDYA. Permissible load 24V 0.1ADC
	RSO	Converter reset	Outputs the reset signal to the inverter when the reset signal is input to the power regeneration common converter. Connect to the inverter terminal RES. Permissible load 24V 0.1ADC
	SE	Open collector output common	Common to the terminals RDYA, RDYB and RSO. Connect to the inverter terminal SD.
Contact	A, B, C	Alarm output	Change-over outputs which indicate that the protective function of the power regeneration common converter was activated to stop the output. Alarm: No continuity across B-C (continuity across A-C), normal: Continuity across B-C (no continuity across A-C) Permissible load 230V 0.3AAC, 30V 0.3ADC

(3) Description of inverter connection terminals

Type	Symbol	Terminal Name	Description
Main circuit	P, N	DC power input	Connect to the power regeneration common converter terminals P/L+, N/L-.
	R1, S1	Control circuit power input	For the FR-A700, F700, A500, F500 or V500 series, remove the jumpers across the inverter terminals R-R1 and S-S1, and input external power to these terminals. For the FR-E500, S500, C500 or F500J series, the inverter does not have the terminals R1, S1 so uses the DC power input from the terminals P, N as the control power.
		Ground	Securely connect to the earth.
Control circuit	X10 (MRS)	Output stop	Shuts off the inverter output when the power regeneration common converter is faulty or the converter reset signal is input. Connect to the power regeneration common converter terminal RDYB. For the FR-A700, F700, E700, D700, A500, F500 or V500 series, assign the X10 signal to any of the input terminals. For the FR-E500, S500, C500 or F500J series, use the terminal MRS as you cannot assign the X10 signal. If the terminal MRS is already used, assign another MRS signal to any of the input terminals.
	RES	Converter reset	When the reset signal is input to the power regeneration common converter, the reset signal is also input to the inverter. Connect to the power regeneration common converter terminal RSO. For the D700, S500, C500 and F500J series, assign the RES signal to any one of the input terminals.
	PC	24VDC power	24V 0.1ADC power. Connect to the power regeneration common converter terminal P24.(Note)
	SD	Contact input common	Common to the contact input terminals. Also acts as a common to the 24V 0.1ADC power (terminal PC).

Note: When used as the 24V power, the terminal PC cannot prevent a sneak path for transistor output.

2.2.2 Wiring of the main circuit

(1) Wiring instructions

- 1) Crimping terminals with insulation sleeves are recommended for use with the power and inverter cables.
- 2) Strictly observe the order of wiring in the connection example when performing wiring between the dedicated stand-alone reactor and power regeneration common converter and wiring between the power supply and terminals R/L11, S/L21, T/MC1. (Match the phase sequence of the power supply.) Incorrect connection will damage the power regeneration common converter.
- 3) Make sure to connect the terminal R/L11, S/L21, T/MC1 to the power supply.
Running the inverter without connecting the terminals will damage the power regeneration common converter.
- 4) Connect a DC power supply between the power regeneration common converter and inverter with correct polarity.
- 5) After wiring, wire off-cuts must not be left in the power regeneration common converter.
Wire off-cuts can cause an alarm, failure or malfunction. Always keep the power regeneration common converter clean.
When drilling mounting holes in a control box etc., exercise care to prevent chips and other foreign matter from entering the power regeneration common converter.
- 6) Electromagnetic wave interference
The input/output (main circuit) of the power regeneration common converter and inverter includes harmonic components, which may interfere with the communication devices (such as AM radios) used near the power regeneration common converter and inverter. In this case, install the FR-BIF optional radio noise filter (for use in the input side only) or FR-BSF01 or FR-BLF line noise filter to minimize interference.
- 7) When rewiring after operation, make sure that the CHARGE lamp has gone off, and when more than 10 minutes have elapsed after power-off, check with a meter that the voltage is zero. After that, start rewiring work. For some time after power-off, there is a dangerous voltage in the capacitor.
- 8) Be sure to connect terminal RDY of the FR-CV to the X10 or MRS signal assigned terminal of the inverter, and connect terminal SE of the FR-CV to terminal SD of the inverter. Without proper connecting, FR-CV will be damaged.

Notes on Grounding

- To prevent an electric shock, the dedicated stand-alone reactor, power regeneration common converter, inverter and motor must be grounded.
- Use the dedicated ground terminal to ground the power regeneration common converter. (Do not use the screws in the case, chassis, etc.)
- Use the reactor mounting screw to earth the dedicated stand-alone reactor.
Use the screw in the ⊕ marked .
- The ground cable should be as thick as possible. Its gauge should be equal to or larger than those indicated in the following table. The grounding point should be as near as possible to the power regeneration common converter to minimize the ground cable length.

(Unit: mm²)

Capacity	Ground Cable Gauge	
	200V class	400V class
7.5kW (10HP)	5.5	3.5
11kW, 15kW (15HP, 20HP)	14	8
22kW to 37kW (30 to 50HP)	22	14
55kW (75HP)	38	22

(2) Terminal block layout of the power circuit

In the main circuit of the power regeneration common converter, the terminals are arranged as shown below:

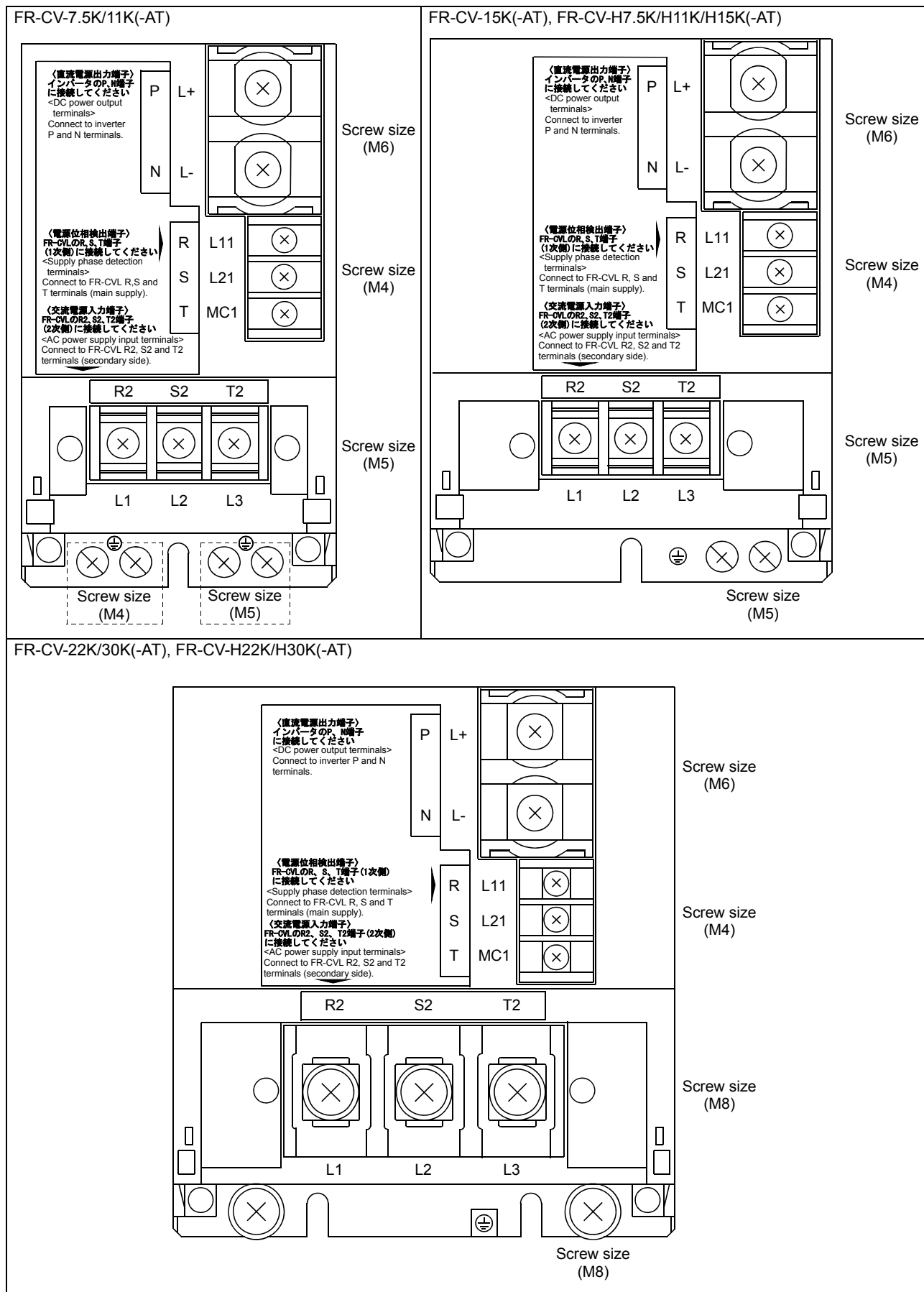

FR-CV-37K

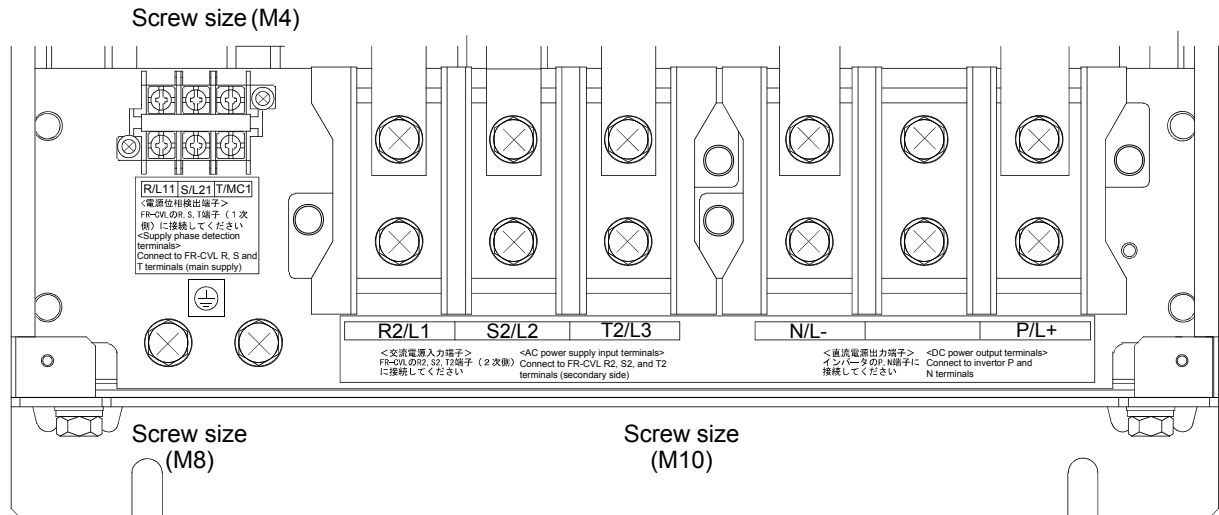

FR-CV-55K

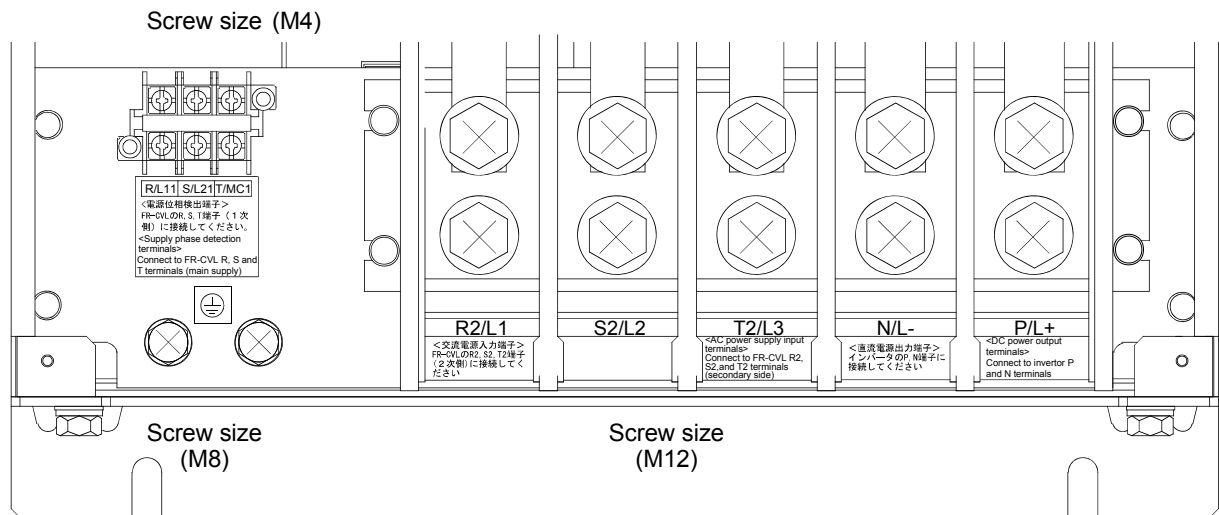

FR-CV-H37K/H55K

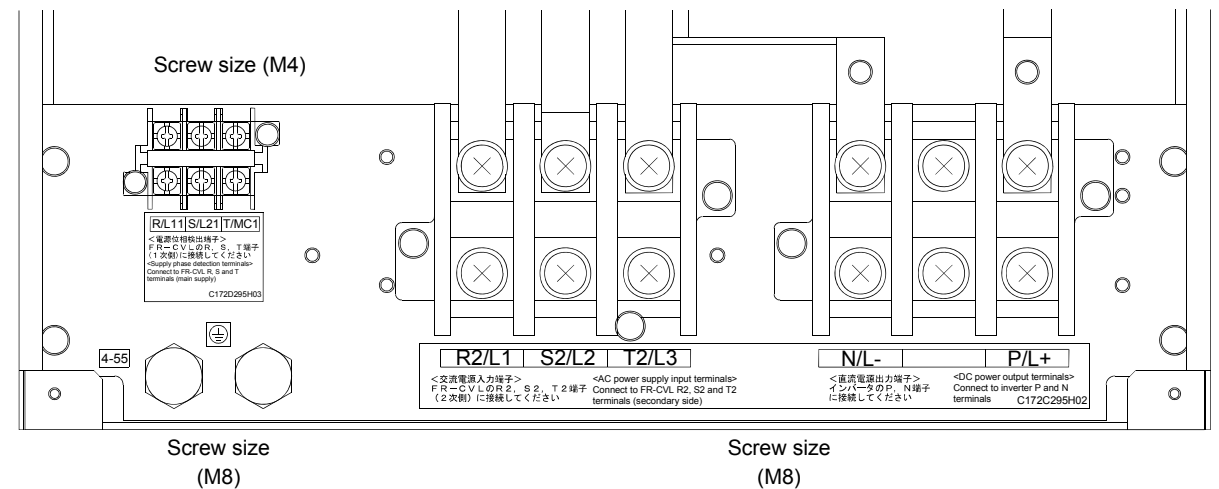

(3) Cables, crimping terminals, etc.

Refer to the following for the cables, crimping terminals and terminal tightening torques used for the power regeneration common converter.

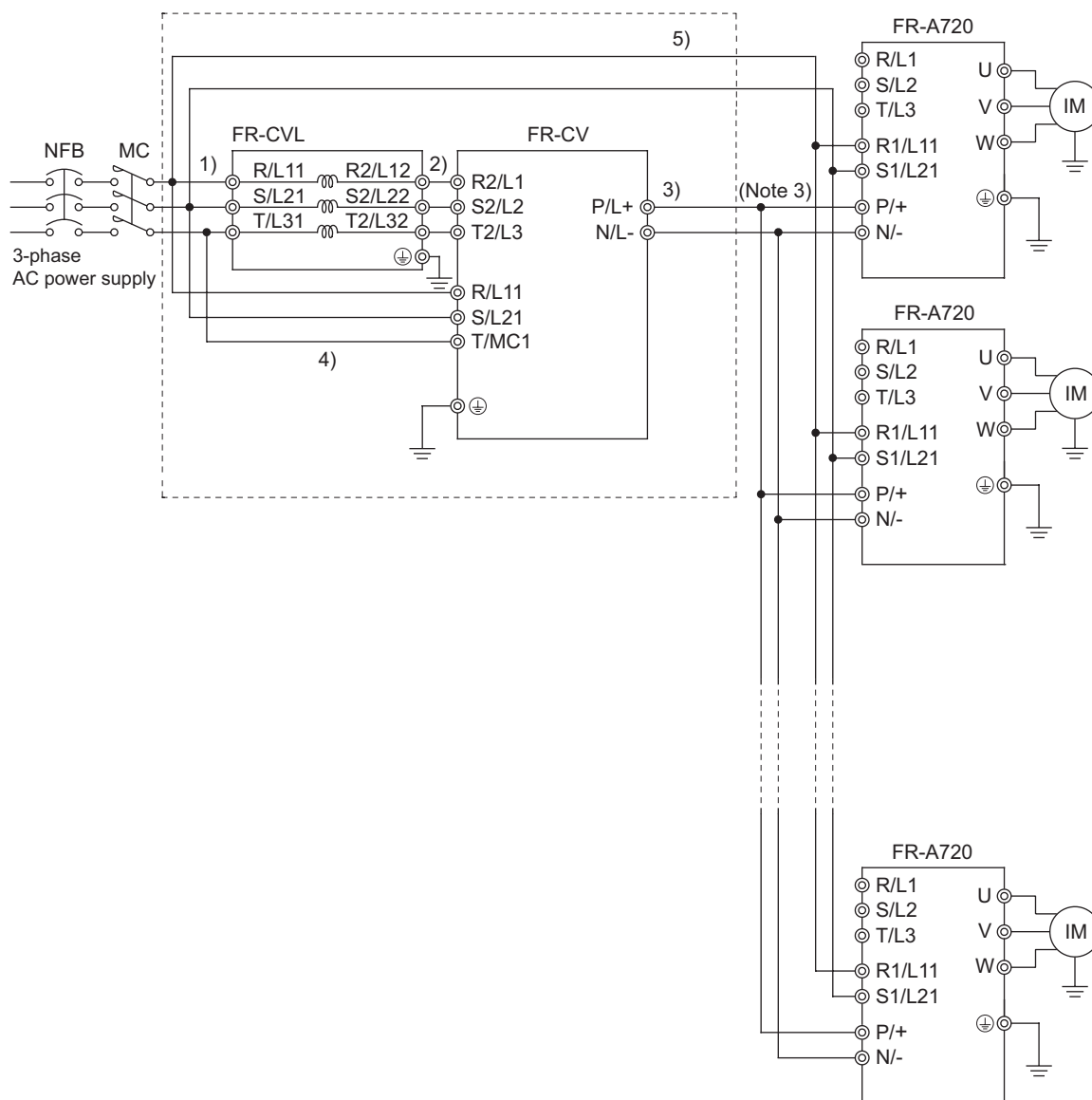

- Note: 1. The cables used should be 75°C (167F°) copper cables.
 2. Tighten the terminal screws to the specified torques.
 Undertightening can cause a short or misoperation.
 Overtightening can cause the screws and unit to be damaged, resulting in a short or misoperation.
 3. Do not insert the NFB between terminals P - N (P/L+ - P/+, N/L- - N/-).

Wiring

1) Connection of power supply and dedicated stand-alone reactor

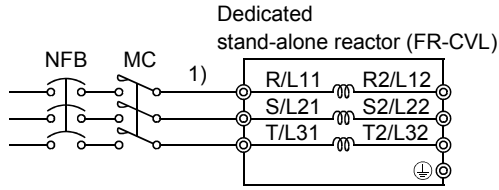

Dedicated Stand-Alone Reactor Model	Terminal Name	Terminal Screw Size	Tightening Torque N•m	Crimping Terminals	Cables	
					mm ²	AWG
FR-CVL-7.5K	R/L11, S/L21, T/L31	M5	2.5	14-5	14	6
FR-CVL-11K		M5	2.5	14-5	14	6
FR-CVL-15K		M6	4.4	22-6	22	4
FR-CVL-22K		M6	4.4	38-6	38	2
FR-CVL-30K		M6	4.4	60-6	60	1/0
FR-CVL-37K		M10	14.7	100-10	100	4/0
FR-CVL-55K		M10	14.7	150-10	150	MCM300
FR-CVL-H7.5K		M5	2.5	3.5-5	3.5	12
FR-CVL-H11K		M5	2.5	5.5-5	5.5	10
FR-CVL-H15K		M5	2.5	14-5	14	6
FR-CVL-H22K		M6	4.4	22-6	22	4
FR-CVL-H30K		M6	4.4	22-6	22	4
FR-CVL-H37K		M8	7.8	38-8	38	2
FR-CVL-H55K		M8	7.8	60-8	60	1/0

Note: Wire the cables so that the phase sequence is always identical to those of the wiring in 2) and 4). Connection in wrong phase sequence will damage the power regeneration common converter.

2) Connection of dedicated stand-alone reactor and power regeneration common converter

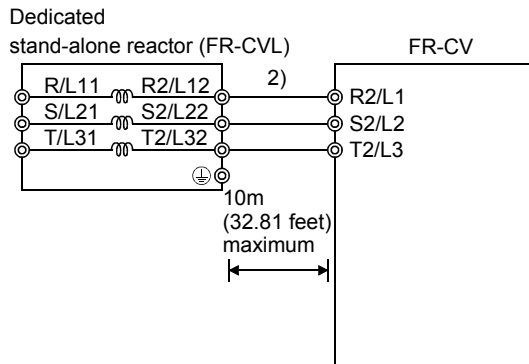

Dedicated Stand-Alone Reactor Model	Terminal Name	Terminal Screw Size	Tightening Torque N•m	Crimping Terminals	Cables	
					mm ²	AWG
FR-CVL-7.5K	R2/L12, S2/L22, T2/L32	M5	2.5	14-5	14	6
FR-CVL-11K		M5	2.5	14-5	14	6
FR-CVL-15K		M6	4.4	22-6	22	4
FR-CVL-22K		M6	4.4	38-6	38	2
FR-CVL-30K		M6	4.4	60-6	60	1/0
FR-CVL-37K		M10	14.7	100-10	100	4/0
FR-CVL-55K		M10	14.7	150-10	150	MCM300
FR-CVL-H7.5K		M5	2.5	3.5-5	3.5	12
FR-CVL-H11K		M5	2.5	5.5-5	5.5	10
FR-CVL-H15K		M5	2.5	14-5	14	6
FR-CVL-H22K		M6	4.4	22-6	22	4
FR-CVL-H30K		M6	4.4	22-6	22	4
FR-CVL-H37K		M8	7.8	38-8	38	2
FR-CVL-H55K		M8	7.8	60-8	60	1/0

Power Regeneration Common Converter Model	Terminal Name	Terminal Screw Size	Tightening Torque N•m	Crimping Terminals	Cables	
					mm ²	AWG
FR-CV-7.5K	R2/L1, S2/L2, T2/L3	M5	2.5	14-5	14	6
FR-CV-11K		M5	2.5	14-5	14	6
FR-CV-15K		M5	2.5	22-S6 (Note 2)	22	4
FR-CV-22K		M8	7.8	38-8	38	2
FR-CV-30K		M8	7.8	CB60-S8 (Note 2)	60	1/0
FR-CV-37K		M10	14.7	100-10	100	4/0
FR-CV-55K		M12	24.5	150-12	150	MCM300
FR-CV-H7.5K		M5	2.5	3.5-5	3.5	12
FR-CV-H11K		M5	2.5	5.5-5	5.5	10
FR-CV-H15K		M5	2.5	14-5	14	6
FR-CV-H22K		M8	7.8	22-8	22	4
FR-CV-H30K		M8	7.8	22-8	22	4
FR-CV-H37K		M8	7.8	38-8	38	2
FR-CV-H55K		M8	7.8	60-8	60	1/0

Note: 1. Wire the cables so that the phase sequence is always identical to those of the wiring in 1) and 4). Connection in wrong phase sequence will damage the power regeneration common converter.
 2. Manufactured by J.S.T.

3) Connection of power regeneration common converter and inverter

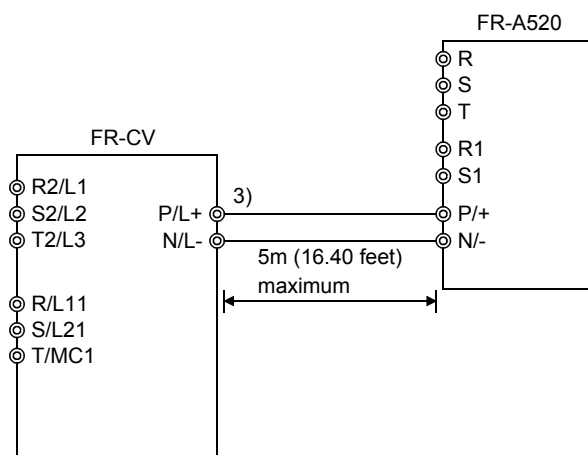

Note: Do not insert the NFB between terminals P - N (P/L+ - P/+, N/L- - N/-). Do not remove a jumper across terminal P/+ and P1.

Power Regeneration Common Converter Model	Terminal Name	Terminal Screw Size	Tightening Torque N•m	Crimping Terminals	Cables	
					mm ²	AWG
FR-CV-7.5K	P/L+, N/L-	M6	4.4	14-6	14	6
FR-CV-11K		M6	4.4	14-6	14	6
FR-CV-15K		M6	4.4	22-6	22	4
FR-CV-22K		M6	4.4	38-S6 (Note 2)	38	2
FR-CV-30K		M6	4.4	CB60-S6 (Note 2)	60	1/0
FR-CV-37K		M10	14.7	100-10	100	4/0
FR-CV-55K		M12	24.5	150-12	150	MCM300
FR-CV-H7.5K		M6	4.4	3.5-6	3.5	12
FR-CV-H11K		M6	4.4	5.5-6	5.5	10
FR-CV-H15K		M6	4.4	14-6	14	6
FR-CV-H22K		M6	4.4	22-6	22	4
FR-CV-H30K		M6	4.4	22-6	22	4
FR-CV-H37K		M8	7.8	38-8	38	2
FR-CV-H55K		M8	7.8	60-8	60	1/0

«Example of connecting two or more inverters»

You can connect up to six inverters to one power regeneration common converter. The capacity of the power regeneration common converter should always be greater than the sum of the connected inverter capacities or the sum of rated inverter currents.

- When connecting several inverters, pay attention to the selection of the cables sizes since junction terminals or jumper cables are used to wire the terminals P, N of the inverters. Make selection so that the inverter capacities are added in order, starting with the one of the remotest inverter.
- When connecting several inverters, connect the inverters in order of larger capacities.
- Specific example

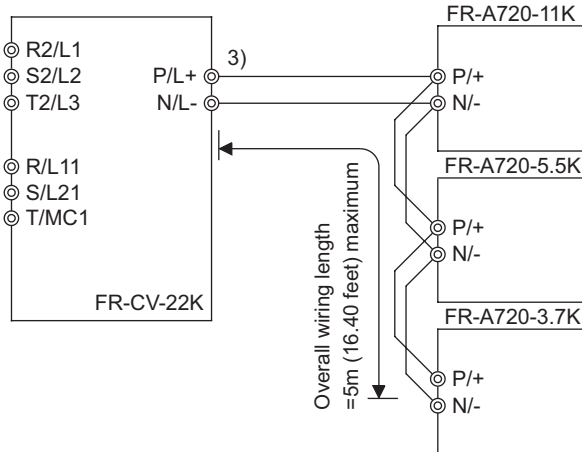

First inverter: Choose 38mm² assuming that the converter capacity is 22K according to the sum of inverter capacities, 11K+5.5K+3.7K=20.2K.

Second inverter: Choose 14mm² assuming that the converter capacity is 11K according to the sum of inverter capacities, 5.5K+3.7K=9.2K.

Third inverter: Choose 3.5mm² according to the inverter capacity, 3.7K.

- Note: 1. Correctly connect the terminals P/L+, N/L- with the inverter terminals P, N. Wrong connection will damage the power regeneration common converter.
 2. Do not insert the NFB between terminals P - N (P/L+ - P/+, N/L- - N/-, P/+ - P/+, N/- - N/-).
 3. Manufactured by J.S.T.

4) Connection of power supply and power regeneration common converter (power supply phase detection terminals)

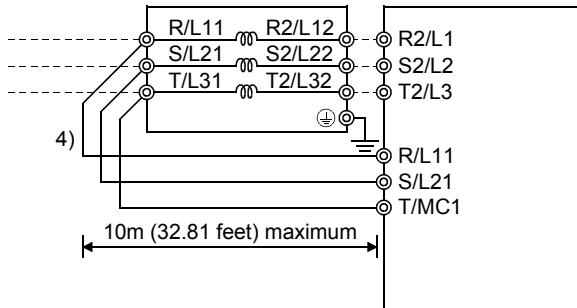

Dedicated Stand-Alone Reactor Model	Terminal Name	Terminal Screw Size	Tightening Torque N•m	Crimping Terminals	Cables	
					mm ²	AWG
FR-CVL-7.5K	R/L11, S/L21, T/L31	M5	2.5	1.25-5	1.25	16
FR-CVL-11K		M5	2.5	1.25-5	1.25	16
FR-CVL-15K		M6	4.4	1.25-6	1.25	16
FR-CVL-22K		M6	4.4	1.25-6	1.25	16
FR-CVL-30K		M6	4.4	1.25-6	1.25	16
FR-CVL-37K		M10	14.7	1.25-10	1.25	16
FR-CVL-55K		M10	14.7	1.25-10	1.25	16
FR-CVL-H7.5K		M5	2.5	1.25-5	1.25	16
FR-CVL-H11K		M5	2.5	1.25-5	1.25	16
FR-CVL-H15K		M5	2.5	1.25-5	1.25	16
FR-CVL-H22K		M6	4.4	1.25-6	1.25	16
FR-CVL-H30K		M6	4.4	1.25-6	1.25	16
FR-CVL-H37K		M8	7.8	1.25-8	1.25	16
FR-CVL-H55K		M8	7.8	1.25-8	1.25	16

Power Regeneration Common Converter Model	Terminal Name	Terminal Screw Size	Tightening Torque N•m	Crimping Terminals	Cables	
					mm ²	AWG
FR-CV-7.5K	R/L11, S/L21, T/MC1	M4	1.5	1.25-4	1.25	16
FR-CV-11K		M4	1.5	1.25-4	1.25	16
FR-CV-15K		M4	1.5	1.25-4	1.25	16
FR-CV-22K		M4	1.5	1.25-4	1.25	16
FR-CV-30K		M4	1.5	1.25-4	1.25	16
FR-CV-37K		M4	1.5	1.25-4	1.25	16
FR-CV-55K		M4	1.5	1.25-4	1.25	16
FR-CV-H7.5K		M4	1.5	1.25-4	1.25	16
FR-CV-H11K		M4	1.5	1.25-4	1.25	16
FR-CV-H15K		M4	1.5	1.25-4	1.25	16
FR-CV-H22K		M4	1.5	1.25-4	1.25	16
FR-CV-H30K		M4	1.5	1.25-4	1.25	16
FR-CV-H37K		M4	1.5	1.25-4	1.25	16
FR-CV-H55K		M4	1.5	1.25-4	1.25	16

Note: 1. Wire the cables so that the phase sequence of the wiring in 4) is always identical to those of the wiring in 1) and 2).
 Connection in wrong phase sequence will damage the power regeneration common converter.
 2. To prevent a malfunction due to noise, run the cables away from the main circuit wiring.
 3. Running the inverter without connecting terminals R/L11, S/L21 and T/MC1 to the power supply will damage the power regeneration common converter.

- 5) Connection of power supply and inverter
 When the model used is the one whose control power is input from R1 and S1, control circuit power must be input to R1 and S1 of the inverter. At this time, remove the jumpers across R-R1, S-S1.
 Cable size: 0.75mm² to 2mm²

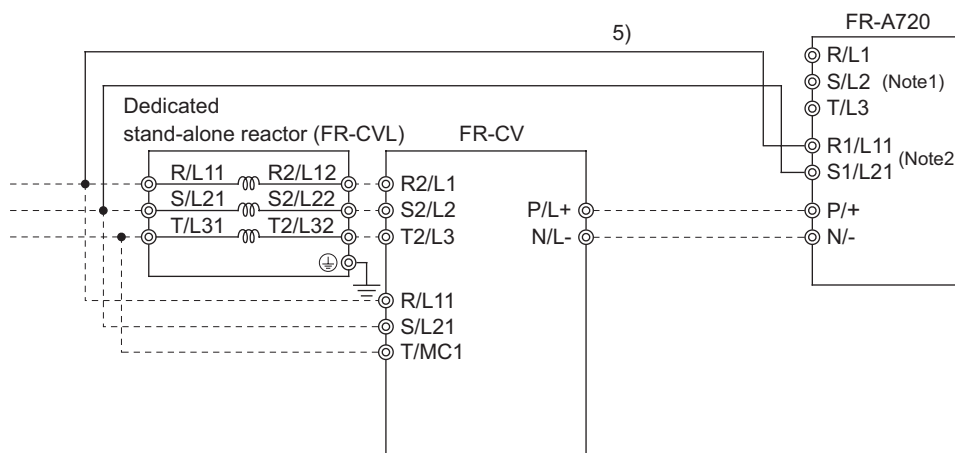

Note: 1. Never connect a power supply to the inverter terminals R, S, T. Accidental connection will damage the inverter and power regeneration common converter.
 2. For the FR-A700, F700, A500, F500 or V500 series, disconnect the jumpers across terminals R-R1, S-S1 and connect the control power supply to terminals R1, S1. For the FR-E700, D700, E500, S500, C500 or F500J series, there are no terminals R1, S1 and you need not make the above connection.

2.2.3 Wiring of the control circuit

(1) Wiring instructions

- 1) The terminals SD, SE are common to the I/O signals and are isolated from each other. Must not be earthed (grounded).
- 2) Shielded or twisted cables must be used for connection to the control circuit terminals, and also run away from the main and power circuits (including the 200V relay sequence circuit).
- 3) The input signals to the control circuit are micro currents. When contacts are required, use two or more parallel micro signal contacts or a twin contact to prevent a contact fault.
- 4) It is recommended to use the cables of 0.3mm² to 0.75mm² gauge for connection to the control circuit terminals.

(2) Terminal block layout

In the control circuit of the power regeneration common converter, the terminals are arranged as shown below:

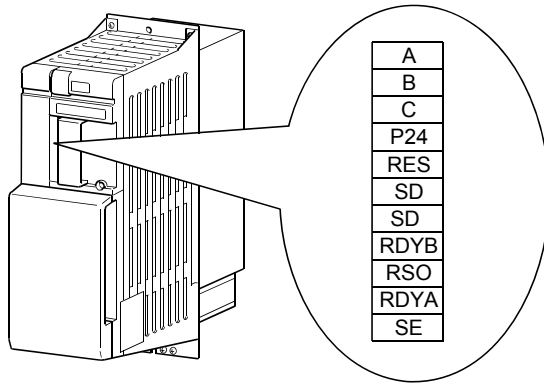

(3) Wiring procedure

- 1) For the wiring of the control circuit, strip the sheaths of the cables and use them as they are. Over-stripping may cause a short circuit with the neighboring cable. Under-stripping may cause cable disconnection.

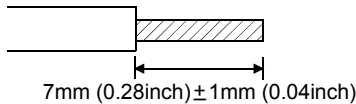

- 2) When using bar terminals or solid cables for wiring, use those of not more than 0.9mm (0.04inch) in diameter. If the diameter is greater than 0.9mm (0.04inch), the screw threads may be damaged when tightened.
- 3) Loosen the terminal screw and insert the cable into the terminal.
- 4) Tighten the screw to the specified torque.
Undertightening can cause cable disconnection or malfunction. Overtightening can cause the screw or unit to be damaged, resulting in a short circuit or malfunction.

Tightening torque: 0.25N•m to 0.49N•m

*Use a screwdriver of No. 0.

Note: Wire the stripped cable after twisting it to prevent it from becoming loose.

2.2.4 Design information

- 1) If the machine must be prevented from restarting at recovery of power after a power failure, provide a magnetic contactor in the primary side of the power regeneration common converter and also make up a sequence that will not turn on the start signal of the inverter.
If the start signal (start switch) of the inverter is held, the inverter will automatically restart at recovery of power.
- 2) Configure up a circuit that will always turn off the main circuit power supply terminals R2/L1, S2/L2, T2/L3 as soon as the power supply phase detection terminals R/L11, S/L21, T/MC1 turn off.
- 3) Since the input signals to the control circuit are on a low level, use two parallel micro signal contacts or a twin contact for contact inputs to prevent a contact fault.
- 4) Do not apply a voltage directly to the alarm output signal terminals (A, B, C).
Always apply a voltage to these terminals via a relay coil, lamp, etc.
- 5) Make sure that the specifications and rating match the system requirements.

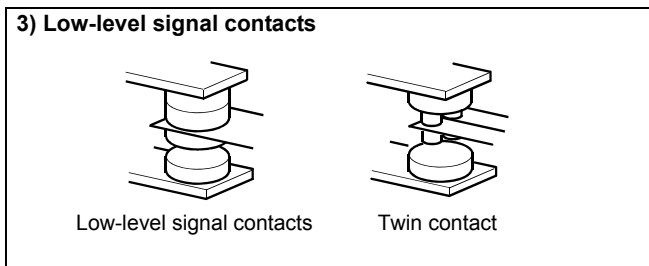

2.3 Operation

2.3.1 Pre-operation checks

When installation and wiring are over, make the following checks prior to power-on.

- 1) Check the wiring for incorrect connection. Especially check that the phase sequence and polarity of the main circuit wiring are correct.
- 2) Check for a short circuit caused by wire off-cuts.
- 3) Check for loose terminal screws.
- 4) Make sure that the machine is free of damage.
- 5) Set the parameter values to match the operating machine system environment.
For the FR-A700, F700, A500, F500 or V500 series, **set 2 (high power factor converter, power regeneration common converter) in Pr. 30 "Regenerative function selection"**.
- 6) Perform test operation after making sure that safety is ensured if the machine should become out of control.
- 7) Perform test operation and make sure that the machine operates safely under light load at a low frequency.
After that, start operation.

Note: Do not conduct an insulation resistance test with a megger in the power regeneration common converter.

2.3.2 Power-on and operation

Before switching power on, check the following:

- **Installation check**

Make sure that the inverter is installed correctly in a proper location. (Refer to page 10.)

- **Wiring check**

Make sure that the main and control circuits are wired correctly.

Make sure that the options and peripheral devices are selected and connected correctly.

(Refer to page 12.)

- **Switch power on.**

Power-on is complete when the CHARGE lamp is lit correctly and the LED displays correct data.

The LED display gives the following indications at power-on.

LED Display		→	(Flicker)	
Converter status	Power on During initialization	During alarm detection	If the DC voltage is higher than the input power supply voltage at power-on, regenerative operation is performed. At this time, the bottom segment flickers.	During normal operation (Driving status)

Note: If the cooling fan has stopped due to a fault, the LED display shows a flickering . (400V class only)
(Refer to page 30.)

- **Start operation.**

Turn on the start signal of the inverter. The motor accelerates to a given speed. At this time, the LED display of the power regeneration common converter shows .

Turn off the start signal of the inverter. The motor decelerates to a stop. The LED display of the power regeneration common converter shows according to the magnitude of the regenerative energy.

LED Display		(Flicker)
Converter status	During driving operation (During stop)	During regenerative operation When the regeneration converter performs switching operation, the bottom segment flickers.

Note: When the power regeneration common converter is regenerating power, the dedicated stand-alone reactor generates sound but it is not a fault.

2.4 Other wiring

2.4.1 Power harmonics

Power harmonics may be generated from the power regeneration common converter, affecting generators, power capacitors, etc. Power harmonics are different in generation source, frequency and transmission path from radio frequency (RF) noise and leakage currents.

● The differences between harmonics and RF noise indicated below:

Item	Harmonics	RF Noise
Frequency	Normally 40th to 50th degrees or less, (up to 3kHz or less)	High frequency (several 10kHz to 1GHz order)
Environment	To wire paths, power impedance	Across spaces, distance, laying paths
Quantitative understanding	Logical computation is possible	Occurs randomly, quantitative understanding is difficult.
Generated amount	Approximately proportional to load capacity	According to current fluctuation rate (larger with faster switching)
Immunity of affected device	Specified in standards for each device.	Differs according to maker's device specifications.

● Safeguard

The harmonic current generated from the power regeneration common converter to the power supply differs according to various conditions such as the wiring impedance, whether a power factor improving reactor is used or not, and output frequency and output current on the load side.

For the output frequency and output current, the adequate method is to obtain them under rated load at the maximum operating frequency.

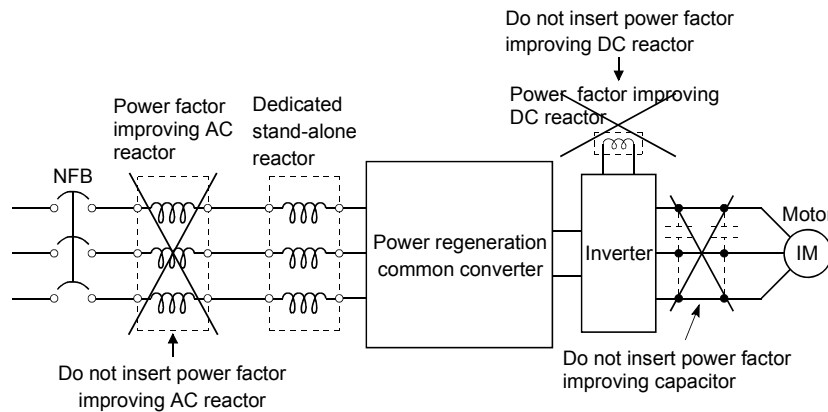

Note: A power factor improving capacitor or surge suppressor on the inverter's output may overheat or be damaged due to the harmonics of the inverter output. Also, when an overcurrent flows in the inverter, the overcurrent protection is activated, Hence, when the motor is driven by the inverter, do not install a capacitor or surge suppressor on the inverter's output. Do not use the power factor improving AC reactor (FR-BAL) since using it may degrade the power regeneration function.

2.4.2 Noise types and reduction techniques

Some noises enter the power regeneration common converter causing it to misoperate and others are radiated by the power regeneration common converter causing misoperation of peripheral devices. Though the power regeneration common converter is designed to be insusceptible to noise, it handles low-level signals, so it requires the following basic measures to be taken. Also, since the inverter chops the output at a high carrier frequency, it could generate noise. If these noises cause peripheral devices to misoperate, measures should be taken to suppress the noise. The measures differ slightly depending on noise propagation paths.

1) Basic measures

- Do not run the power cables (I/O cables) and signal cables of the power regeneration common converter in parallel with each other and do not bundle them.
- Use twisted shielded cables for the detector connection and control signal cables and connect the sheathes of the shielded cables to terminal SD.
- Ground the power regeneration common converter and inverter, motor, etc. at one point.

2) Measures against noises which enter and cause misoperation of the power regeneration common converter
When devices which generate many noises (which use magnetic contactors, magnetic brakes, many relays, for example) are installed near the power regeneration common converter and the inverter may be effected by noise, the following measures must be taken:

- Provide surge suppressors for devices that generate noise to suppress noise.
- Fit data line filters to signal cables.
- Ground the shields of the detector connection and control signal cables with cable clamp metal.

3) Measures against noise which is radiated by the power regeneration common converter causing misoperation of peripheral devices.

Power regeneration common converter-generated noise is largely classified into those radiated by the cables connected to the power regeneration common converter and power regeneration common converter main circuit (I/O), those electromagnetically and electrostatically inducted to the signal cables of the peripheral devices close to the main circuit power supply, and those transmitted through the power supply cables.

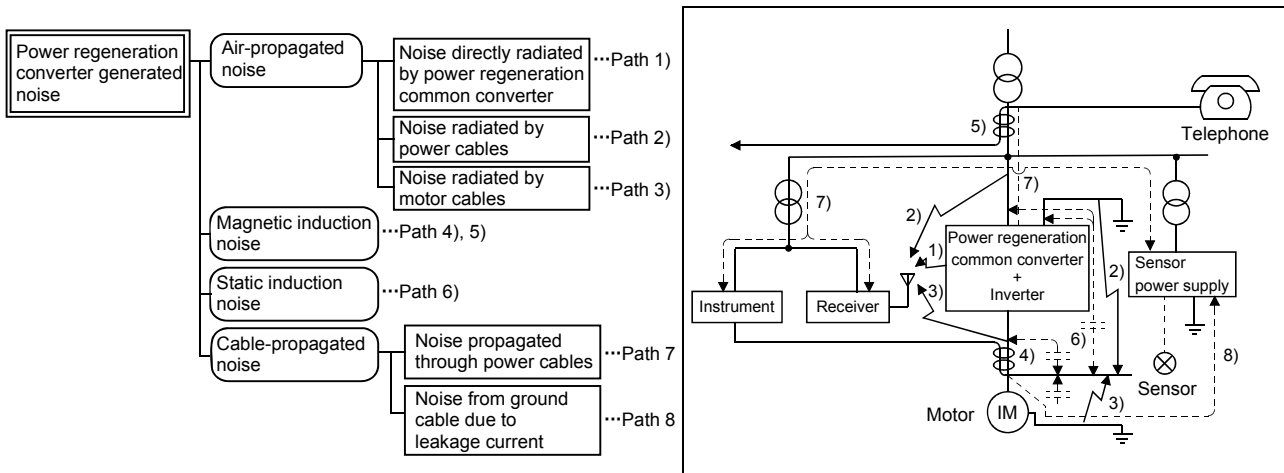

Noise Path	Measures
1) 2) 3)	<p>When devices which handle low-level signals and are susceptible to misoperation due to noise (such as instruments, receivers and sensors) are installed near the power regeneration common converter and their signal cables are contained in the same panel as the inverter or are run near the power regeneration common converter, the devices may be affected by air-propagated noises and the following measures must be taken:</p> <p>(1) Install easily affected devices as far away as possible from the power regeneration common converter.</p> <p>(2) Run easily affected signal cables as far away as possible from the power regeneration common converter.</p> <p>(3) Do not run the signal cables and power cables (power regeneration common converter I/O cables) in parallel with each other and do not bundle them.</p> <p>(4) Inset line noise filters into I/O and radio noise filters into input side to suppress cable-radiated noises.</p> <p>(5) Use shielded cables for signal cables and power cables and run them in individual metal conduits to reduce further effects.</p>

Noise Path	Measures
4) 5) 6)	When the signal cables are run in parallel with or bundled with the power cables, magnetic and static induction noise may be propagated to the signal cables to effect the devices and the following measures must be taken: (1) Install easily affected devices as far away as possible from the power regeneration common converter. (2) Run easily affected signal cables as far away as possible from the power regeneration common converter. (3) Do not run the signal cables and power cables (power regeneration common converter I/O cables) in parallel with each other and do not bundle them. (4) Use shielded cables for signal cables and power cables and run them in individual metal conduits to reduce further effects.
7)	When the power supplies of the peripheral devices are connected to the power supply of the power regeneration common converter within the same line, power regeneration common converter-generated noise may flow back through the power supply cables to misoperate the devices and the following measures must be taken: (1) Install the radio noise filter (FR-BIF) to the power cables (input cables) of the power regeneration common converter. (2) Install the line noise filter (FR-BLF, FR-BSF01) to the power cables (I/O cables) of the power regeneration common converter.
8)	When a closed loop circuit is formed by connecting the peripheral device wiring to the power regeneration common converter, leakage current may flow through the ground cable of the power regeneration common converter to affect the device. In such a case, disconnection of the ground cable of the device may cause the device to operate properly.

2.4.3 Peripheral devices

(1) Selection of peripheral devices

Refer to the following list and prepare appropriate peripheral devices:

1) 200V class

Power Regeneration Common Converter Type	Applicable Capacity (kW (HP))	Power Supply Capacity (kVA)	Rated current of Circuit Breaker	Magnetic Contactor
FR-CV-7.5K (-AT)	7.5 (10)	17	100AF 60A	S-N35
FR-CV-11K (-AT)	11 (15)	20	100AF 75A	S-N50
FR-CV-15K (-AT)	15 (20)	28	225AF 125A	S-N65
FR-CV-22K (-AT)	22 (30)	41	225AF 175A	S-N95
FR-CV-30K (-AT)	30 (40)	52	225AF 225A	S-N125
FR-CV-37K	37 (50)	66	400AF 250A	S-N150
FR-CV-55K	55 (75)	100	400AF 400A	S-N220

2) 400V class

Power Regeneration Common Converter Type	Applicable Capacity (kW (HP))	Power Supply Capacity (kVA)	Rated current of Circuit Breaker	Magnetic Contactor
FR-CV-H7.5K (-AT)	7.5 (10)	17	30AF 30A	S-N20
FR-CV-H11K (-AT)	11 (15)	20	50AF 50A	S-N20
FR-CV-H15K (-AT)	15 (20)	28	100AF 60A	S-N25
FR-CV-H22K (-AT)	22 (30)	41	100AF 100A	S-N50
FR-CV-H30K (-AT)	30 (40)	52	225AF 125A	S-N65
FR-CV-H37K	37 (50)	66	225AF 150A	S-N80
FR-CV-H55K	55 (75)	100	225AF 200A	S-N125

Note: 1. For installations in the United States or Canada, the circuit breaker must be inverse time or instantaneous trip type.

2. When the breaker on the primary side of the power regeneration common converter tripped, check for wiring fault (e.g. short circuit), damage to internal parts of the inverter (power regeneration common converter), etc. Identify the cause of the breaker trip, then power on the breaker after removing the cause of the trip.

(2) Selection the rated sensitivity current for the earth leakage circuit breaker

When using the earth leakage circuit breaker with the inverter circuit, select its rated sensitivity current as follows, independent of the carrier frequency setting:

● Breaker for harmonic and surge

Rated sensitivity current:

$$I\Delta n \geq 10 \times (I_{g1} + I_{gn} + I_{g2} + I_{gm})$$

● Standard breaker

Rated sensitivity current:

$$I\Delta n \geq 10 \times \{I_{g1} + I_{gn} + 3 \times (I_{g2} + I_{gm})\}$$

I_{g1}, I_{g2} : leakage currents of cable path during commercial power supply operation

I_{gn}^* : leakage current of noise filter on power regeneration common converter input side

I_{gm} : leakage current of motor during commercial power supply operation

Example of leakage current per 1km in cable path during commercial power supply operation when the CV cable is routed in metal conduit (200V 60Hz)

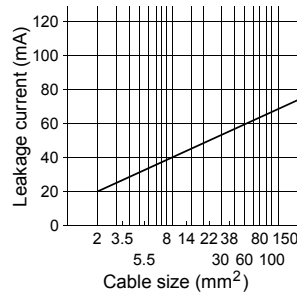

Leakage current example of 3-phase induction motor during commercial power supply operation (200V 60Hz)

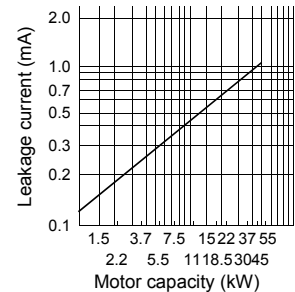

<Example>

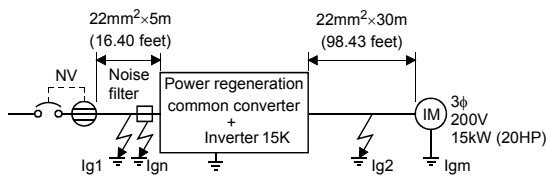

	Breaker for Harmonic and Surge	Standard Breaker
Leakage current I_{g1} (mA)	$50 \times \frac{5m (16.40 \text{ feet})}{1000m (3280.80 \text{ feet})} = 0.25$	
Leakage current I_{gn} (mA)	0 (without noise filter)	
Leakage current I_{g2} (mA)	$50 \times \frac{30m (98.43 \text{ feet})}{1000m (3280.80 \text{ feet})} = 1.50$	
Motor leakage current I_{gm} (mA)	0.57	
Total leakage current (mA)	2.32	6.46
Rated sensitivity current (mA) ($\geq I_g \times 10$)	30	100

- Note:
- The NV should be installed to the primary (power supply) side of the power regeneration common converter.
 - Ground fault in the secondary side of the inverter can be detected at the running frequency of 120Hz or lower.
 - In the Δ connection neutral point grounded system, the sensitivity current becomes worse for ground faults in the inverter secondary side. Hence, the protective grounding of the load equipment should be 10Ω or less.
 - When the breaker is installed on the secondary side of the inverter, it may be unnecessarily operated by harmonics if the effective value is less than the rating. In this case, do not install it since the eddy current and hysteresis loss increase and the temperature rises.
 - The following models are standard breakers
 BV-C1, BC-V, NVB, NV-L, NV-G2N, NV-G3NA, and NV-2F type leakage current relays (except for NV-ZHA), AA neutral wire, NV with open phase protection
 The following models are breakers for harmonic and surge
 NV-C/NV-S/MN series, NV30-FA, NV50-FA, BV-C2, leakage current alarm breaker(NF-Z), NV-ZHA, NV-H

* Be careful of the leakage current value of the noise filter installed on the power regeneration common converter input side.

2.4.4 Instructions for UL and cUL

(Standards to comply with: UL 508C, CSA C22.2 No. 14)

(1) Installation

The equipment has been approved as a product for use in an enclosure.

Design the enclosure so that the ambient temperature, humidity and ambience of the power regeneration common converter will satisfy the above specifications. (Refer to page 44.)

(2) Branch circuit protection

For installation in United States, branch circuit protection must be provided, in accordance with the National Electrical Code and any applicable local codes.

For installation in Canada, branch circuit protection must be provided in accordance with the Canada Electrical Code and any applicable provincial codes.

(3) Short circuit ratings

Suitable For Use in A Circuit Capable of Delivering Not More Than 10kA rms Symmetrical Amperes, 500V Maximum.

(4) Wiring of the power supply and motor

Screw the cables wired to the input (R, S, T) and output (P, N) terminals and control circuit of the power regeneration common converter to the specified tightening torque using UL-recognized, 75°C or higher rated copper wires and round crimping terminals. Crimp the crimping terminals with the crimping tool recommended by the terminal maker.

CHAPTER 3

PROTECTIVE FUNCTIONS

This chapter explains the "protective functions" of this product.

Always read the instructions before using the equipment.

- 3.1 Errors (Alarms)..... 30
- 3.2 Precautions for Maintenance and Inspection..... 32

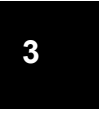
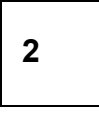

3.1 Errors (Alarms)

If any fault has occurred in the power regeneration common converter, the corresponding protective function is activated and the error (alarm) indication appears automatically on the LED display.

When the protective function is activated, find the cause and take proper action.

If an alarm stop has occurred, the power regeneration common converter must be reset to restart it.

●When the protective function is activated, take the corresponding corrective action, then reset the power regeneration common converter, and resume operation.

●Resetting method









When the protective function is activated and the power regeneration common converter has stopped its output, the inverter output is also shut off. Unless reset, the protective function of the power regeneration common converter cannot be deactivated. To reset, use either of the following two methods: switch power off once, then on again; short the reset terminal RES-SD for more than 0.1 seconds, then open.

( CPU alarm may be reset only by switching power off, then on again.)

If RES-SD are kept shorted, the LED shows  .

3.1.1 Error (alarm) definitions

(1) Major faults

LED Display	Name	Description	Check Point
	Overcurrent protection	The current of the power regeneration common converter module exceeded the specified value. (Detected only in the regeneration mode.)	Check for sudden acceleration/ deceleration. Check for sudden load change. Check for incorrect wiring. Check for occurrence of instantaneous power failure.
	Main circuit device overheat	The main circuit device overheated.	Check that the cooling fan is not at a stop. Check for operation under overload. Check for too high ambient temperatures.
	Overvoltage protection	The bus voltage (voltage across terminals P/L+ and N/L-) of the power regeneration common converter fell to or below the specified value.	Check for sudden deceleration. Check for sudden load change.
	Electronic overcurrent protection	Thermal protection of power regeneration common converter module.	Check for operation under overload.
	Undervoltage	The bus voltage (voltage across terminals P/L+ and N/L-) of the power regeneration common converter fell to or below the specified value.	Check for a start of large-capacity motor.
	Phase failure	A phase failure occurred in the input power supply.	Check for incorrect wiring.
	CPU alarm	The operation of the built-in CPU did not end with the predetermined time. An alarm was detected in the memory circuit or A/D converter of the power regeneration common converter.	Contact your sales representative or distributor.
	Instantaneous power failure alarm	An instantaneous power failure of more than 15ms and less than 100ms occurred. When an instantaneous power failure of not less than 100ms occurred, the same operation as in power-on reset is performed.	Find the cause of instantaneous power failure.
	Power supply alarm	The power supply frequency fell out of the specified value. Phase detection could not be made at power-on.	Check for incorrect wiring.

(2) Minor fault

LED Display	Name	Description	Check Point
	Fan fault (400V class only)	The cooling fan stopped due to a fault.	Check the cooling fan for a fault.

! CAUTION

! At occurrence of an instantaneous power failure alarm or power supply alarm, the inverter output may be shut off to coast the motor before the power regeneration common converter outputs an alarm. In a system where an alarm will cause an emergency stop, configure up a system that will not only provide alarm outputs of the power regeneration common converter and inverter but also make a stop if the RUN signal of the inverter turns off.

3.1.2 Alarm symptoms and check points

Symptom	Check point
Operation is not normal.	Check connection. <ul style="list-style-type: none"> ● Check for incorrect wiring. ● Check that a normal power supply voltage is applied. ● Check that the phase sequence matches. ● Check for a short across terminals RES-SD.
The CHARGE lamp is not lit.	Check connection. <ul style="list-style-type: none"> ● Check for incorrect connection. ● Check that the main circuit terminals R2/L1, S2/L2, T2/L3 are wired correctly.
The reactor becomes abnormally hot.	Check connection. <ul style="list-style-type: none"> ● Check for incorrect connection. ● Check that the phase sequence matches.
The inverter cannot be run.	Check setting. <ul style="list-style-type: none"> ● For the FR-A700, F700, A500, F500 or V500 series inverter, check that the Pr. 30 "Regenerative function select" setting is 2 (high power factor converter, power regeneration common converter).

3.2 Precautions for Maintenance and Inspection

The power regeneration common converter is a static unit mainly consisting of semiconductor devices. Daily inspection must be performed to prevent any fault from occurring due to adverse influence by the operating environment, such as temperature, humidity, dust, dirt and vibration, changes in the parts with time, service life, and other factors.

3.2.1 Precautions for maintenance and inspection

For some short time after the power is switched off, a high voltage remains in the smoothing capacitor. When accessing the power regeneration common converter for inspection, switch power off. When more than 10 minutes have elapsed, make sure that the voltage across the main circuit terminals P/L+-N/L- of the inverter is 30VDC or less using a tester, etc.

The dedicated stand-alone reactor is very hot. Exercise care not to get burnt.

3.2.2 Check items

(1) Daily inspections

- Check the following:
 - 1)Improper installation environment
 - 2)Cooling system fault
 - 3)Unusual vibration and noise
 - 4)Unusual overheating and discoloration
- During operation, check the power regeneration common converter input voltages using a tester.

(2) Cleaning

Always run the power regeneration common converter in a clean state.

When cleaning the inverter, gently wipe dirty areas with a soft cloth immersed in neutral detergent or ethanol.

Note: Do not use solvent, such as acetone, benzene, toluene and alcohol, as they will cause the power regeneration common converter surface paint to peel off.
Do not use detergent or alcohol to clean the LED display section, which is easily affected by them.

3.2.3 Periodic inspection

Check the areas inaccessible during operation and requiring periodic inspection. For periodic inspection, consult us.

- 1) Cooling system: Clean the air filter, etc.
- 2) Screws and bolts: These parts may become loose due to vibration, temperature changes, etc.
Check that they are tightened securely and retighten as necessary.
- 3) Conductors and insulating materials: Check for corrosion and damage.
- 4) Insulation resistance: Measure.
- 5) Cooling fan, relay: Check and change if necessary.

3.2.4 Insulation resistance test using megger

- 1) Before performing the insulation resistance test using a megger on the external circuit, disconnect the cables from all terminals of the power regeneration common converter so that the test voltage is not applied to the inverter.
- 2) For the continuity test of the control circuit, use a meter (high resistance range) and do not use the megger or buzzer.
- 3) For the power regeneration common converter, conduct the insulation resistance test on the main circuit only as shown below and do not perform the test on the control circuit. (Use a 500VDC megger.)

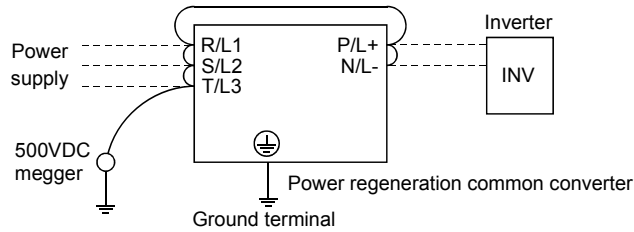

3.2.5 Pressure test

Do not conduct a pressure test. The power regeneration common converter's main circuit uses semiconductors, which may be deteriorated if a pressure test is made.

Precautions for Maintenance and Inspection

3.2.6 Daily and Periodic Inspection

Area of Inspection	Inspection Item	Description	Interval			Method	Criterion	Instrument	Customer setting
			Daily	Periodic					
				1 year	2 year				
General	Surrounding environment	Check ambient temperature, humidity, dust, dirt, etc.	○			(Refer to page 10)	Ambient temperature: (constant torque) -10°C to + 50°C (14°F to 122°F), non-freezing. (Variable torque) -10°C to + 40°C (14°F to 104°F), non-freezing. Ambient humidity: 90% or less, non-condensing.	Thermometer, hygrometer, recrder	
	Overall unit	Check for unusual vibration and noese.	○			Visual and auditory checks.	No fault.		
	Power supply voltage	Check that main circuit voltage is normal.	○			Measure voltage across power regeneration common converter terminals R2/L1, S2/L2, T2/L3.	Within permissible AC voltage fluctuation (Refer to page 44)	Meter, digital multimeter	
Mian circuit	General	(1) Check with megger (across main circuit terminals and ground terminal). (2) Check for loose screws and bolts. (3) Check for overheating of each part. (4)Clean.			○	(1) Disconnect all cables from power regeneration common converter and measure across terminals R2/L1, S2/L2, T2/L3, P/L+, N/L- and ground terminal with megger. (2) Re-tighten. (3) Visual check.	(1) 5M Ω or more. (2),(3) No fault.	500VDC class megger	
	Conductors, cables	(1) Check conductors for distortion. (2) Check cable sheaths for breakage.			○	(1), (2) Visual check.	(1), (2) No fault.		
	Terminal block	Check for damage.			○	Visual check.	No fault		
	Converter module	Check resistance across terminals.			○	Disconnect cables from inverter and measure across terminals R2/L1, S2/L2, T2/L3, P/L+, N/L- with a meter range of 100Ω.	(Refer to page 35)	Analog meter	
	Smoothing capacitor	(1) Check for liquid leakage. (2) Check the safety valve for projection or bulge. (3) Measure capacitance.	○			(1), (2) Visual check. (3) Use capacitance meter to make measurement.	(1), (2) No fault. (3) 85% or more of rated capacitance.	Capacitance meter	
	Relay	(1) Check for chatter during operation. (2) Check for rough surface on contacts.	○			(1) Auditory check. (2) Visual check.	(1) No fault. (2) No fault.		
	Resistor	(1) Check for crack in resistor insulation.	○			(1) Visual check. Cement resistor, wire-wound resistor.	(1) No fault.		

Area of Inspection	Inspection Item	Description	Interval			Method	Criterion	Instrument	Customer setting
			Daily	Periodic					
				1 year	2 year				
Control circuit Protective circuit	Operation check	(1) Perform sequence protective operation test to make sure of no fault in protective and display circuits.				(1) Simulatively connect or disconnect inverter protective circuit output terminals.	(1) Fault must occur because of sequence.		
Cooling system	Cooling fan	(1) Check for unusual vibration and noise. (2) Check for loose connection.	○			(1) Turn by hand with power off. (2) Re-tighten	No unusual vibration, unusual noise.		
Display	Display	(1) Check if LED lamp is blown. (2) Clean.	○			(1) Light indicator lamps on panel. (2) Clean with rag.	(1) Check that lamps are lit.		
	Meter	Check that reading is normal.	○			Check reading of meters on panel.	Must satisfy specified and management values.	Voltmeter, ammeter, etc.	

● **Checking the converter module**

<Preparation>

- (1) Disconnect the external power supply cables (R2/L1, S2/L2, T2/L3, P/L+, N/L-).
- (2) Prepare a meter. (Use 100Ω range.)

<Checking method>

Change the polarity of the tester alternately at the converter terminals R2/L1, S2/L2, T2/L3, P/L+, N/L- and check for continuity.

Note: 1. Before measurement, check that the smoothing capacitor is discharged.
 2. At the time of continuity, the measured value is several to several ten's-of ohms depending on the module type, circuit tester type, etc. If all measured values are almost the same, the modules are without fault.

<Module device numbers and terminals to be checked>

		Tester Polarity		Measured Value
		+	-	
Converter module	D1	R2/L1	P/L+	Discontinuity
		P/L+	R2/L1	Continuity
	D2	S2/L2	P/L+	Discontinuity
		P/L+	S2/L2	Continuity
	D3	T2/L3	P/L+	Discontinuity
		P/L+	T2/L3	Continuity
	D4	R2/L1	N/L-	Continuity
		N/L-	R2/L1	Discontinuity
	D5	S2/L2	N/L-	Continuity
		N/L-	S2/L2	Discontinuity
	D6	T2/L3	N/L-	Continuity
		N/L-	T2/L3	Discontinuity

(Assumes the use of an analog meter.)

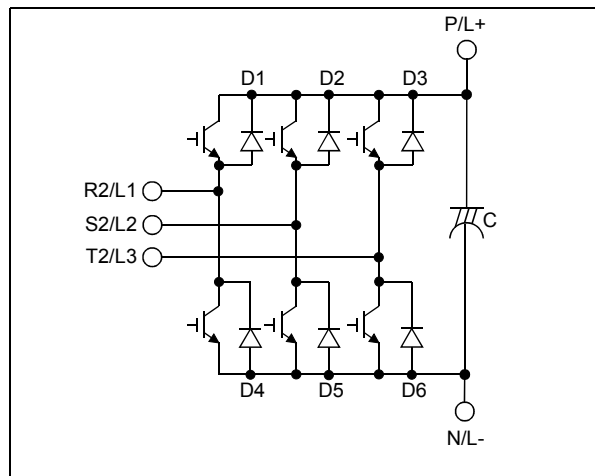

3.2.7 Replacement of parts

The power regeneration common converter consists of many electronic parts such as semiconductor devices. The following parts may deteriorate with age because of their structures or physical characteristics, leading to reduced performance or failure of the power regeneration common converter. For preventive maintenance, the parts must be changed periodically.

The part replacement guidelines for the power regeneration common converter are indicated in the following table. Lamps and other short-life parts must also be changed during periodic inspection.

Replacement Parts of the power regeneration common converter

Part Name	Standard Replacement Interval	Description
Cooling fan	2 to 3 years	Change (as required)
Smoothing capacitor in main circuit	5 years	Change (as required)
Smoothing capacitor on control board	5 years	Change the board (as required)
Relays	—	Change as required

Note: For part replacement, contact the nearest Mitsubishi FA center.

(1) Cooling fan

The cooling fan cools heat-generating parts such as the main circuit semiconductor devices. The life of the cooling fan bearing is usually 10,000 to 35,000 hours. Hence, the cooling fan must be changed every 2 to 3 years if the inverter is run continuously. When unusual noise and/or vibration is noticed during inspection, the cooling fan must be changed immediately. Change the cooling fan in the following procedure.

● Heat sink outside mounting structure model

FR-CV-7.5K to 30K, FR-CV-H11K to H30K

- 1) Disconnect the wiring of the power regeneration common converter unit and remove the unit from the enclosure.
- 2) Remove the screws that fasten the cooling fan.

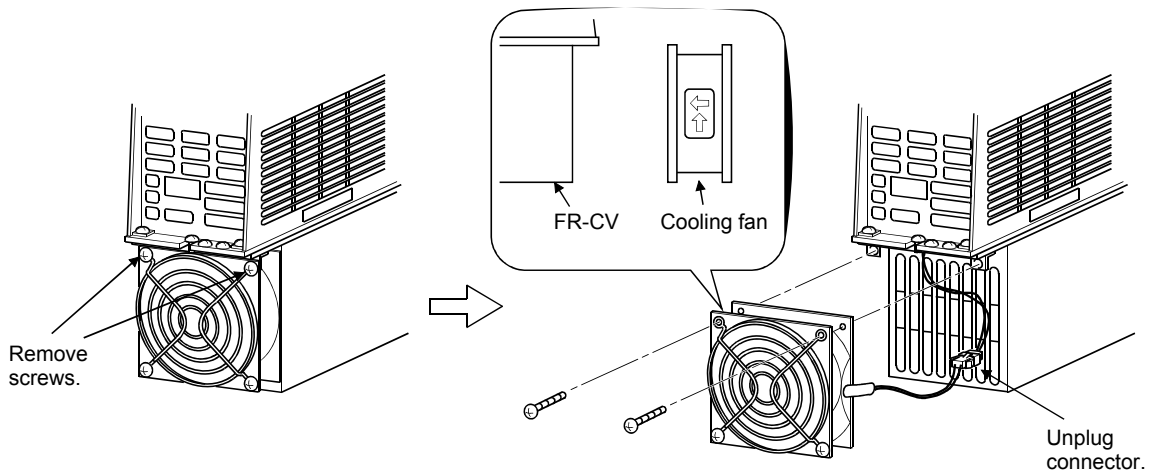

- 3) Unplugging the connector of the cooling fan removes the cooling fan from the unit.
- 4) Replace the cooling fan. Reinstall the cooling fan so that the arrows of the fan point in the directions as shown above.
- 5) Reinstall it to the power regeneration common converter unit in the reverse procedure.

Note: If the air flow is set in the wrong direction, the inverter life can be shorter.

FR-CV-37K/55K, FR-CV-H37K/H55K

- 1) Disconnect the wiring of the power regeneration common converter unit.
- 2) Remove the front cover.

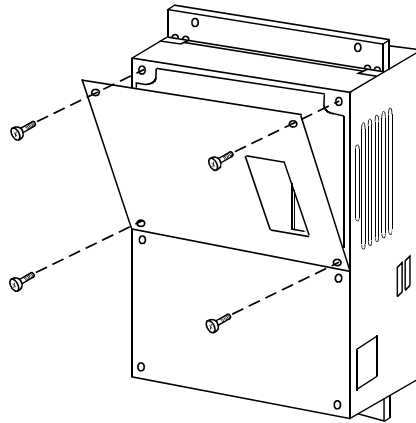

- 3) Unplug the cooling fan connector from the cooling fan connection cable fastening holder.

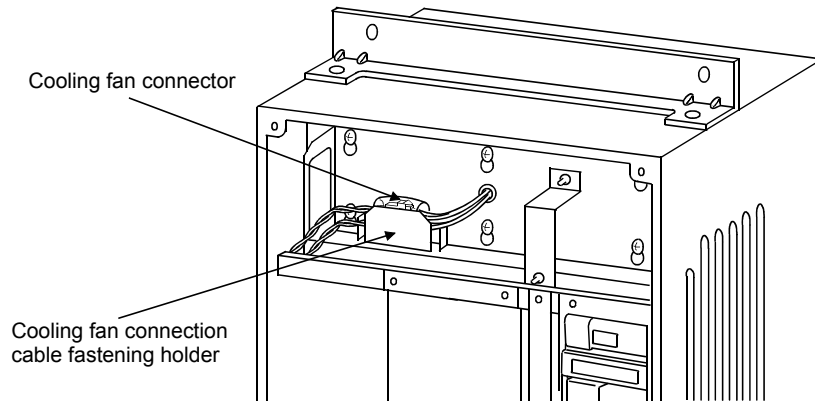

- 4) Shift the protective covers and unplug the connectors.

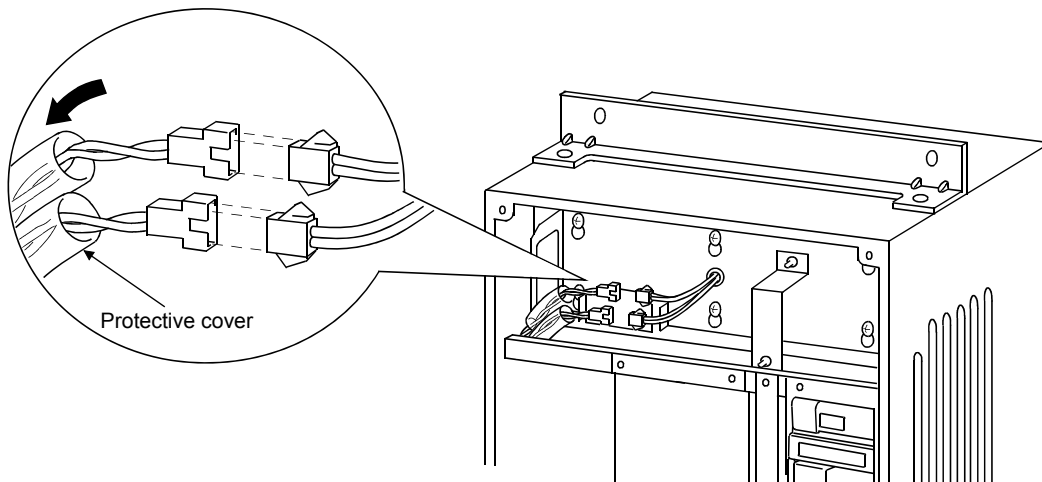

Precautions for Maintenance and Inspection

- 5) Loosen the screws that fasten the cooling fan mounting fixture and pull out the cooling fan mounting fixture. Pull it out slowly, exercising care not to bring the cooling fan into contact with the printed board. (The screw holes of the cooling fan mounting fixture are pear-shaped.)

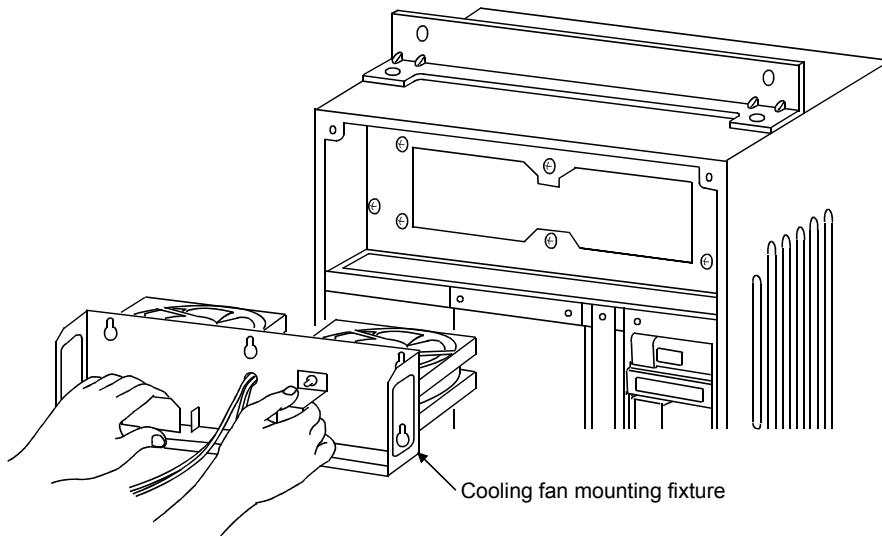

- 6) Pinch the cable bushing with a pair of long-nose pliers etc. and remove the cable bushing.

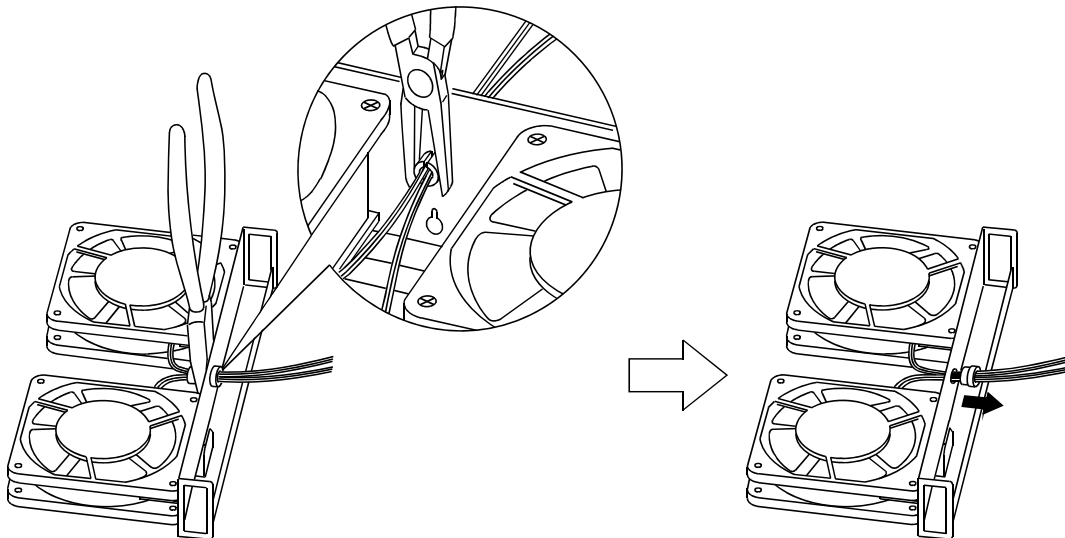

- 7) Remove the cooling fan from the cooling fan mounting fixture, and change the cooling fan. When reinstalling the cooling fan, take care so that the arrows given on the cooling fan point as shown below.

Note: If the air flow is set in the wrong direction, the inverter life can be shorter.

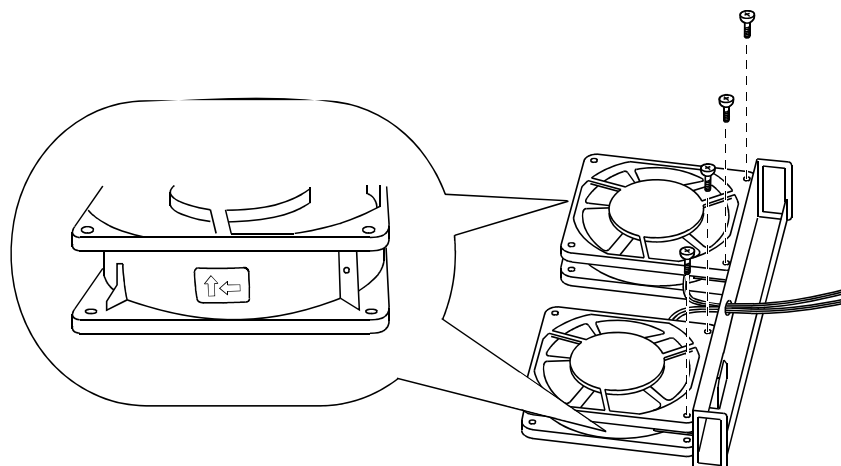

- 8) Reinstall the cooling fan to the power regeneration common converter unit in the reverse procedure.

● Enclosure inside installation structure model

FR-CV-7.5K to 30K(-AT), FR-CV-H7.5K to H30K(-AT)

- 1) Disconnect the wiring of the power regeneration common converter unit.
- 2) Remove the screws in the L-bracket that fasten the cooling fan.

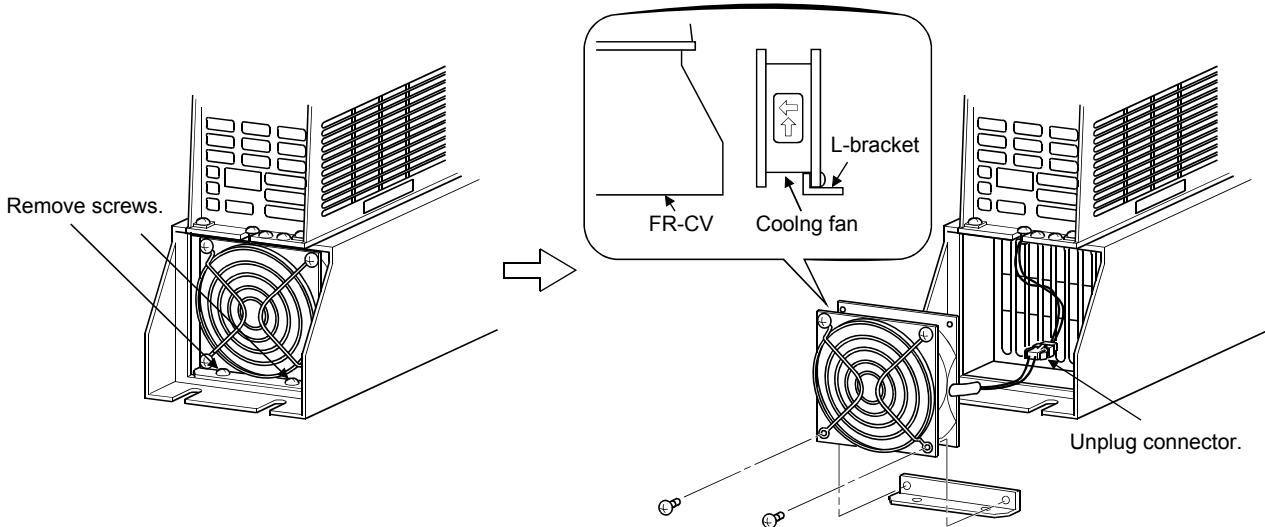

- 3) Unplugging the connector of the cooling fan removes the cooling fan from the unit.
- 4) Remove the L-bracket from the cooling fan to replace the cooling fan.
Reinstall the cooling fan so that the arrows of the fan point in the directions as shown above.
- 5) Reinstall it to the power regeneration common converter unit in the reverse procedure.

Note: If the air flow is set in the wrong direction, the inverter life can be shorter.

(2) Smoothing capacitors

A large-capacity aluminum electrolytic capacitor is used for smoothing the DC in the main circuit, and an aluminum electrolytic capacitor is also used for stabilizing the control power in the control circuit. Their characteristics are adversely affected by ripple current, etc. This is greatly influenced by the ambient temperature and operating conditions. When the inverter is operated in an ordinary, air-conditioned environment, change the capacitors about every 5 years.

Since the capacitors begin to deteriorate rapidly beyond a given period, check them at least once a year (desirably every six months or less when they are approaching the end of their useful life).

Check the following:

- 1) Case (side faces and bottom face for expansion)
- 2) Sealing plate (for remarkable warping and extreme cracks)
- 3) Explosion-proof valve (for excessive valve expansion and operation)
- 4) Appearance, external cracks, discoloration, leakage. When the measured capacitance of the capacitor has reduced below 85% of the rating, change the capacitor.

(3) Relays

To prevent a contact fault, etc., relays must be changed according to the number of accumulative switching times (switching life).

Precautions for Maintenance and Inspection

3.2.8 Measurement of main circuit voltages, currents and power

● Measurement of voltages and currents

When instruments for commercial frequency are used for measurement, measure the following circuits using the instruments given below.

When installing measuring instruments etc. on the output side of the power regeneration common converter, choose the measuring instruments that have allowance in current rating since they may generate heat under the influence of line-to-line leakage currents if the wiring distance between the power regeneration common converter and inverter is long.

The DC voltage, which is developed across the terminals P/L+ and N/L- of the power regeneration common converter, can be measured with a moving-coil instrument (tester). Though it varies with the power supply voltage, the voltage will reduce under load.

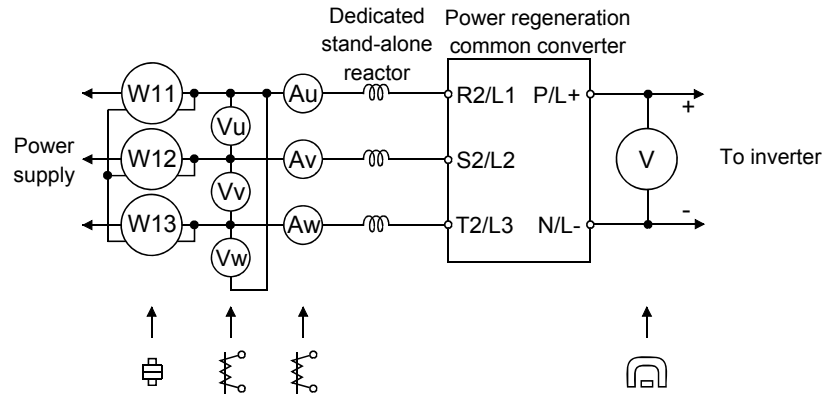

< Typical Measuring Points and Instruments >

● Classification and application by the operation principles of electrical indicator instruments

Type	Symbol	Principle	Indication	Applicable Instrument	Features
Moving-coil type		Utilizes the force that works between the magnetic field of the permanent magnet and the current flowing in the moving coil.	DC (Average value)	Voltmeter, ammeter, resistance meter, thermometer, flux meter, rotating meter	High in sensitivity and most often used. Affected little by consumed power and external magnetic field.
Moving-iron type		Utilizes the force that is produced between the magnetic field of the current flowing in the fixed coil and the moving iron.	AC (Effective value)	Voltmeter, ammeter	Rigidly structured and low priced. Affected greatly by external magnetic field, frequency and waveform.
Electrodyn amometer type	Air core 	Utilizes the force that works between the currents flowing in two coils.	AC/DC (Effective value)	Wattmeter, Voltmeter, ammeter	A wattmeter is graduated equally. Affected greatly by external magnetic field and large in power consumption. Usable as an AC/DC standard instrument.

Measuring Points and Instruments

Item	Measuring Point	Measuring Instrument	Remarks (Reference Measured Value) *
Power supply voltage V1	Across R2/L1-S2/L2, S2/L2-T2/L3, and T2/L3-R2/L1	Moving-iron type AC voltmeter	Commercial power supply Within permissible AC voltage fluctuation (Refer to page 44)
Power supply side current I1	R2/L1, S2/L2 and T2/L3 line currents	Moving-iron type AC ammeter	

MEMO

CHAPTER 4

SPECIFICATIONS

This chapter provides the "specifications" of this product. Always read the instructions before using the equipment.

4.1 Standard Specifications 44

1

2

3

4

4.1 Standard Specifications

4.1.1 Model specifications

● 200V class

Type	Heat sink outside mounting structure FR-CV-□□K	7.5	11	15	22	30	37 (Note 4)	55 (Note 4)		
	Enclosure inside installation structure FR-CV-□□K-AT									
Applicable inverter capacity (Note 1)	kW	7.5	11	15	22	30	37	55		
	HP	10	15	20	30	40	50	75		
Output	Applicable current (A) (Note 1)	33	46	61	90	115	145	215		
	Regenerative braking torque	Short-duration rating	150% torque 60s							
		Continuous rating	100% torque							
Power supply	Rated input AC voltage, frequency	Three phase 200 to 220V 50Hz, 200 to 230V 60Hz								
	Permissible AC voltage fluctuation	Three phase 170 to 242V 50Hz, 170 to 253V 60Hz								
	Permissible frequency fluctuation	±5%								
	Power supply system capacity (kVA) (Note 2)	17	20	28	41	52	66	100		
Protective structure (JEM 1030)		Open type (IP00)								
Cooling system		Forced air cooling								
Approximately weight (kg (lbs))	Heat sink outside mounting structure	5.0 (11.0)	5.0 (11.0)	6.0 (13.2)	9.5 (20.9)	10.5 (23.1)	34 (75.0)	38 (83.8)		
	Enclosure inside installation structure	6.5 (14.3)	6.5 (14.3)	7.5 (16.5)	12.5 (27.6)	13.5 (29.8)				
Input signal		Reset								
Output signal		Ready output signal, inverter run enable signal, converter reset, alarm signal								
Protective functions		Overcurrent protection, overvoltage protection, electronic overcurrent protection, undervoltage, phase failure, CPU alarm, instantaneous power failure alarm, power supply alarm								
Environment	Ambient temperature	-10°C to +50°C (14°F to 122°F) (non-freezing)								
	Ambient humidity	90%RH or less (non-condensing)								
	Storage temperature	-20°C to 50°C (-4°F to 122°F)								
	Ambience	Indoors (free from corrosive gas, flammable gas, oil mist, dust and dirt)								
Altitude		Maximum 1000m (3280.80feet) above sea level for standard operation. After that derate by 3% for every extra 500m (1640.40feet) up to 2500m (8202.00feet) (91%).								
Vibration		5.9m/s ² or less								
Dedicated stand-alone reactor		FR-CVL-7.5K	FR-CVL-11K	FR-CVL-15K	FR-CVL-22K	FR-CVL-30K	FR-CVL-37K	FR-CVL-55K		

● 400V class

Type	Heat sink outside mounting structure FR-CV-H□□K		7.5	11	15	22	30	37 (Note 4)	55 (Note 4)
	Enclosure inside installation structure FR-CV-H□□K-AT								
Applicable inverter capacity (Note 1)		kW	7.5	11	15	22	30	37	55
		HP	10	15	20	30	40	50	75
Output	Applicable current (A) (Note 1)		17	23	31	43	57	71	110
	Regenerative braking torque	Short-duration rating	150% torque 60s						
		Continuous rating	100% torque						
Power supply	Rated input AC voltage, frequency		Three phase 380 to 480V 50Hz/60Hz						
	Permissible AC voltage fluctuation		Three phase 323 to 528V 50Hz/60Hz						
	Permissible frequency fluctuation		±5%						
	Power supply system capacity (kVA) (Note 2)		17	20	28	41	52	66	100
Protective structure (JEM 1030)		Open type (IP00)							
Cooling system		Self-cooling	Forced air cooling						
Approximately weight (kg (lbs))	Heat sink outside mounting structure		6.0 (13.2)	6.0 (13.2)	6.0 (13.2)	10.0 (22.0)	10.0 (22.0)	32.5 (71.7)	32.5 (71.5)
	Enclosure inside installation structure		7.5 (16.5)	7.5 (16.5)	7.5 (16.5)	13.0 (28.7)	13.0 (28.7)		
Input signal		Reset							
Output signal		Ready output signal, inverter run enable signal, converter reset, alarm signal							
Protective functions		Overcurrent protection, overvoltage protection, electronic overcurrent protection, undervoltage, phase failure, CPU alarm, instantaneous power failure alarm, power supply alarm							
Environment	Ambient temperature		-10°C to +50°C (14°F to 122°F) (non-freezing)						
	Ambient humidity		90%RH or less (non-condensing)						
	Storage temperature		-20°C to 50°C (-4°F to 122°F)						
	Ambience		Indoors (free from corrosive gas, flammable gas, oil mist, dust and dirt)						
Altitude		Maximum 1000m (3280.80feet) above sea level for standard operation. After that derate by 3% for every extra 500m (1640.40feet) up to 2500m (8202.00feet) (91%).							
Vibration		5.9m/s ² or less							
Dedicated stand-alone reactor		FR-CVL-H7.5K	FR-CVL-H11K	FR-CVL-H15K	FR-CVL-H22K	FR-CVL-H30K	FR-CVL-H37K	FR-CVL-H55K	

Note: 1. The applicable inverter capacity is the sum total of the inverter capacities (up to six inverters). For the FR-V500 series inverter, the capacity of the main circuit smoothing capacitor is larger than that of other types of transistorized inverter with same capacity. Therefore, use the substituted inverter capacity in the table below for selection.

Actual capacity [K] of the FR-V500	1.5	2.2	3.7	5.5	7.5	11	15	18.5	22	30	37	45	55
Substituted capacity [K] of the FR-V500 for use in combination with the FR-CV.	2.2	3.7	5.5	7.5	11	15	18.5	22	30	37	45	55	55

Example: Applicable inverter capacity for the FR-CV-15K → •FR-A700 series

1) FR-A720-15K

2) FR-A720-11K + FR-A720-3.7K

•FR-V500 series

1) FR-V520-11K

2) FR-V520-7.5K + FR-V520-2.2K

Make selection so that the sum of the rated currents of the used motors does not exceed the applicable current.

- The power supply capacity changes with the values of the power supply side inverter impedances (including those of the input reactor and cables).
- Since the dedicated stand-alone reactor is connected, a voltage may drop to cause motor torque shortage or a current may increase to overheat the motor.
- The FR-CV-37K, 55K and FR-CV-H37K, H55K can be used as either a heat sink outside mounting structure model or an enclosure inside installation structure model by changing its mounting foot position. The mounting foot is factory-set in the heat sink outside mounting position.
(Refer to page 8 for changing the mounting foot position.)

4.1.2 Internal block diagram

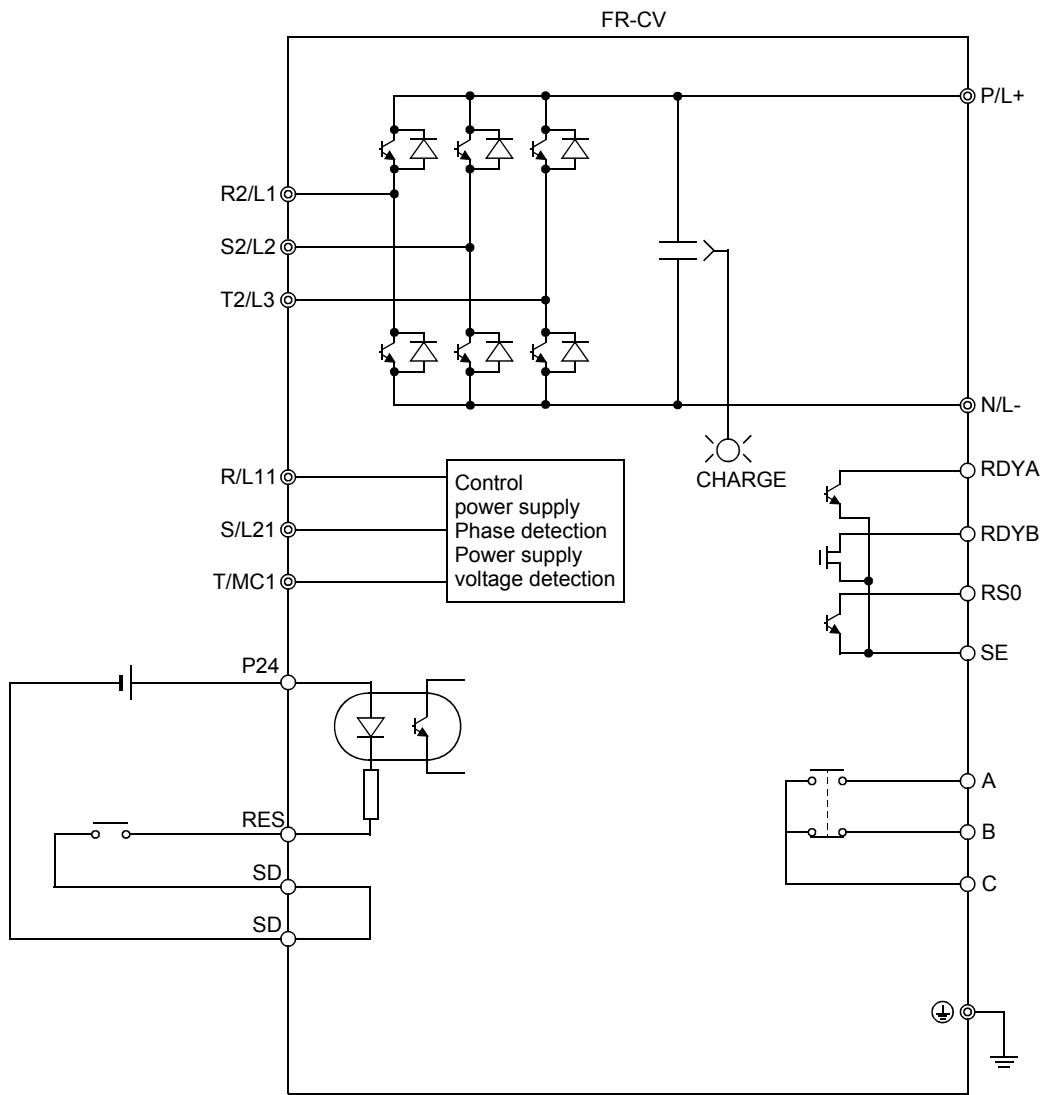

Standard Specifications

4.1.3 Outline drawings

(1) Heat sink outside mounting structure model

● FR-CV-7.5K/11K/15K, FR-CV-H7.5K/H11K/H15K

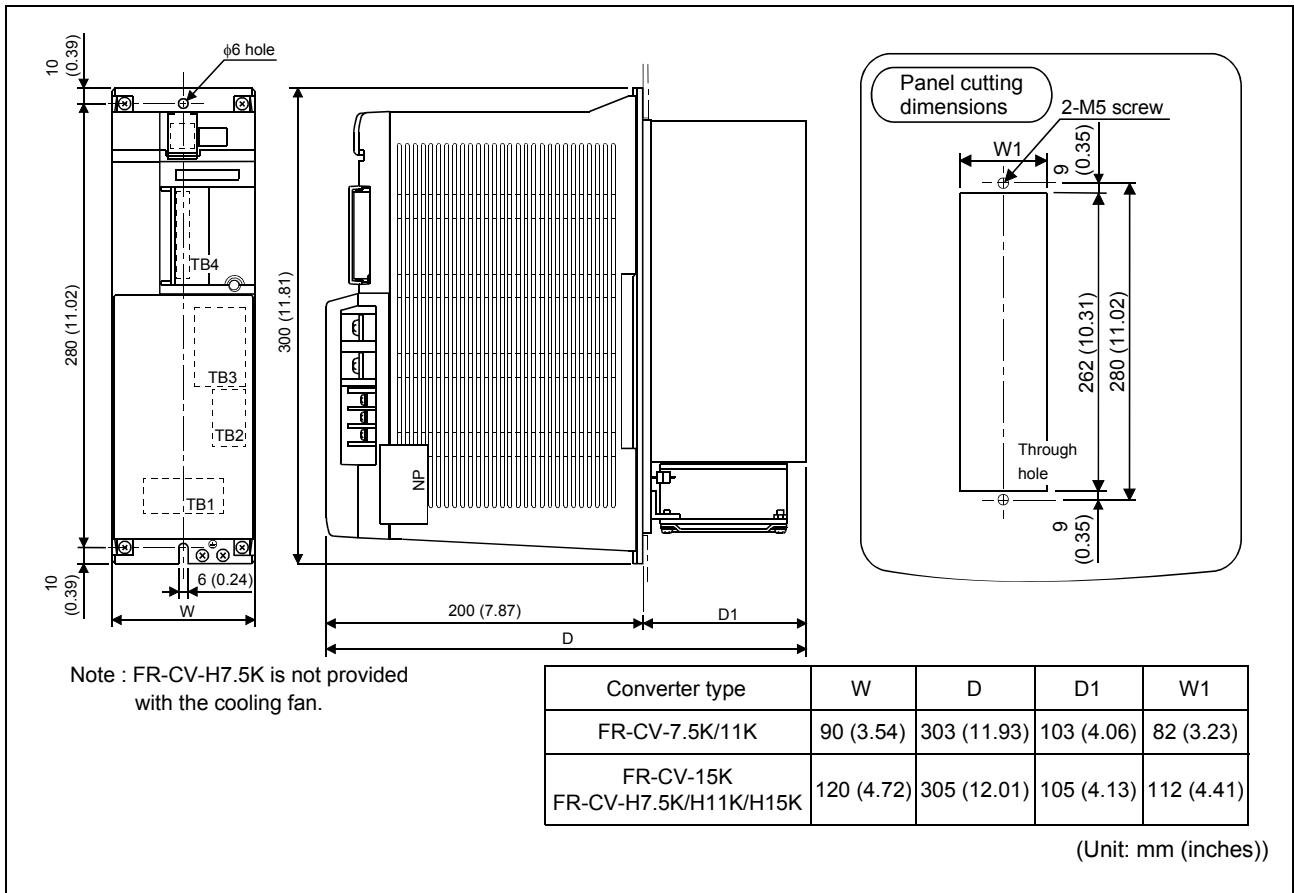

● FR-CV-22K/30K, FR-CV-H22K/H30K

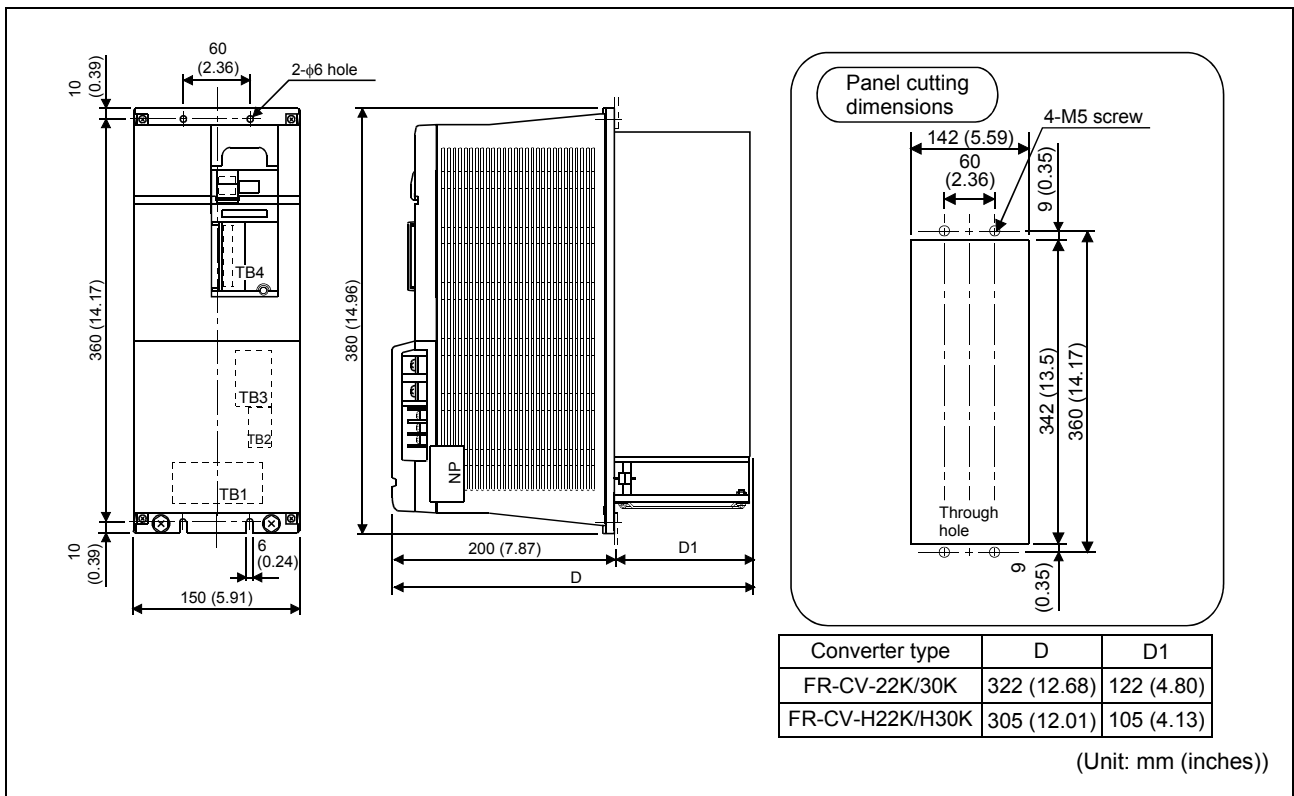

● FR-CV-37K/55K, FR-CV-H37K/H55K

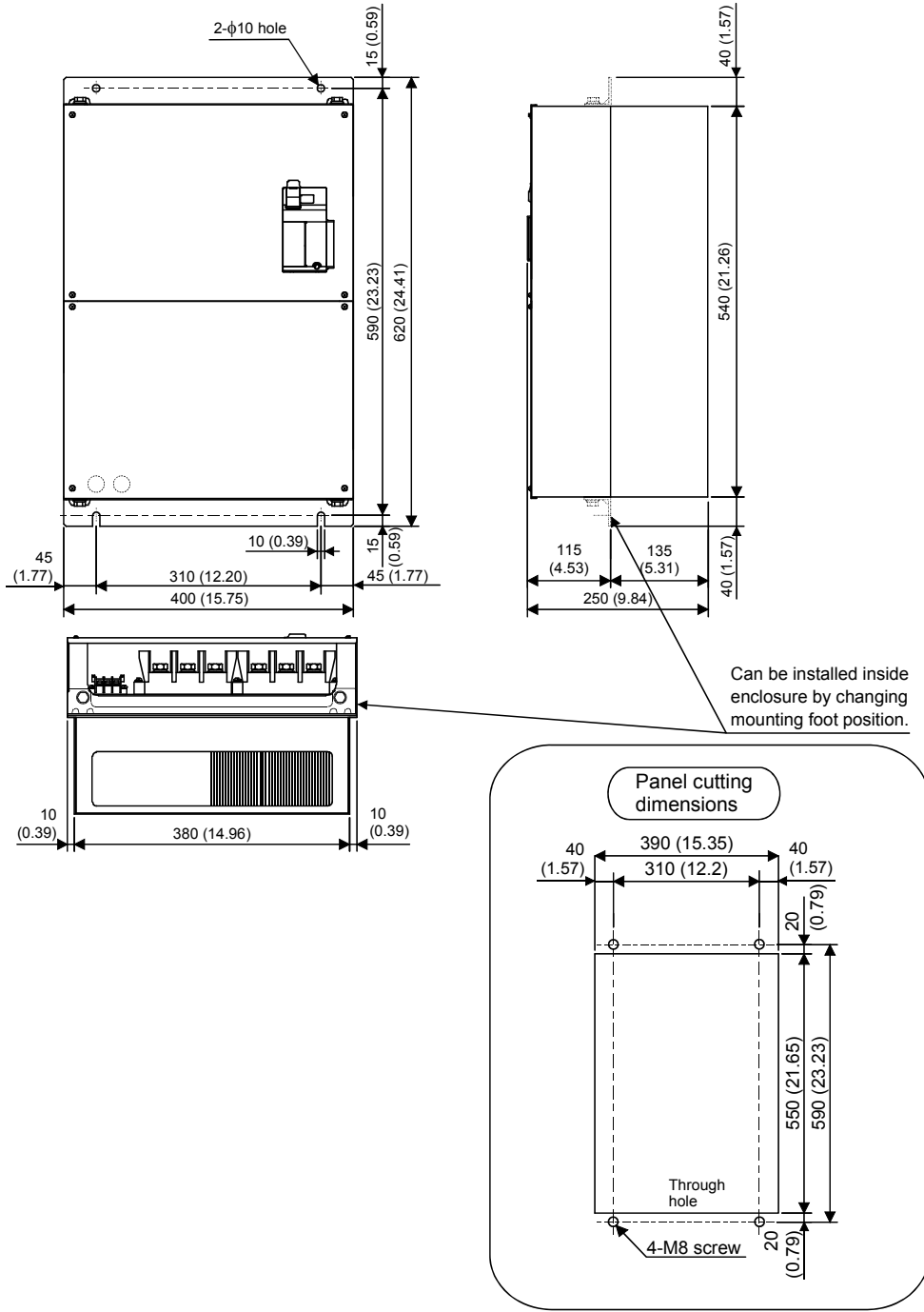

(Unit: mm (inches))

Standard Specifications

(2) Enclosure inside installation structure model

● FR-CV-7.5K/11K/15K-AT, FR-CV-H7.5K/H11K/H15K-AT

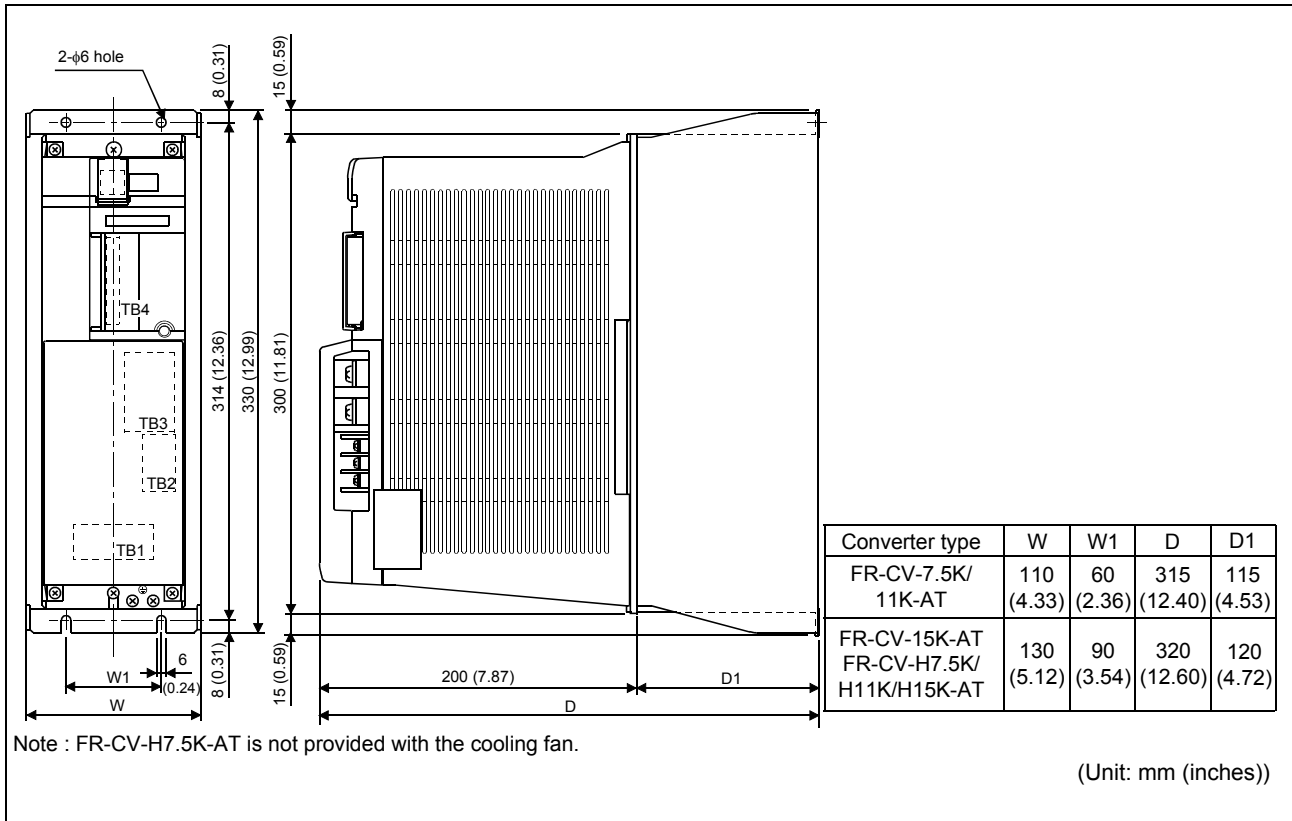

● FR-CV-22K/30K-AT, FR-CV-H22K/H30K-AT

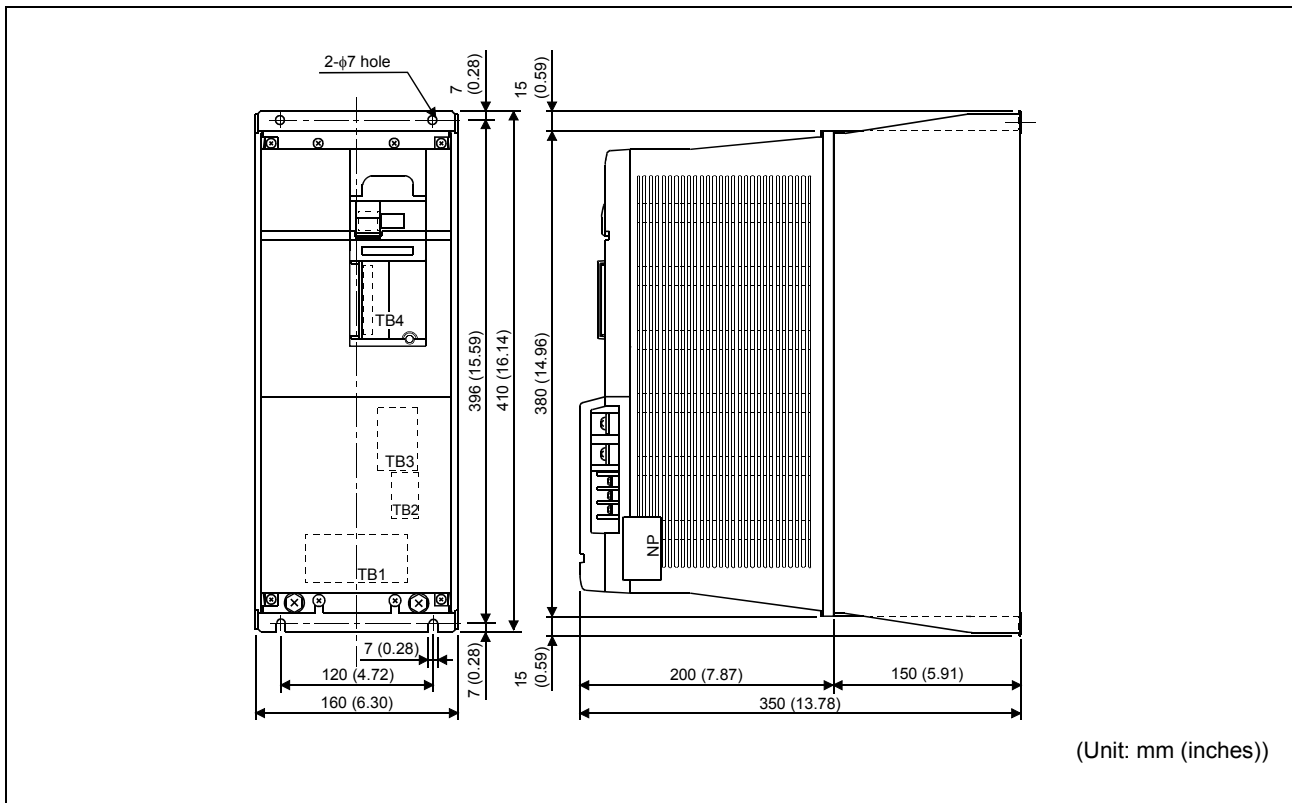

(3) Dedicated stand-alone reactor

1) 200V class

● FR-CVL-7.5K/11K/15K/22K

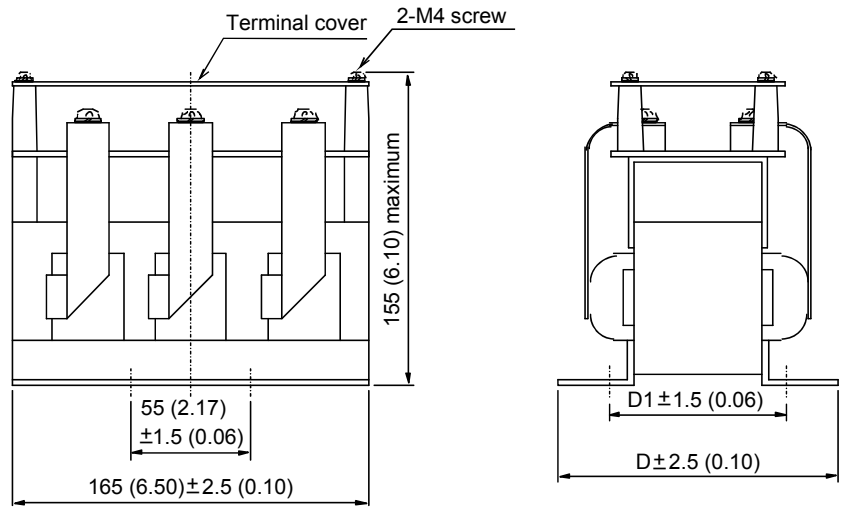
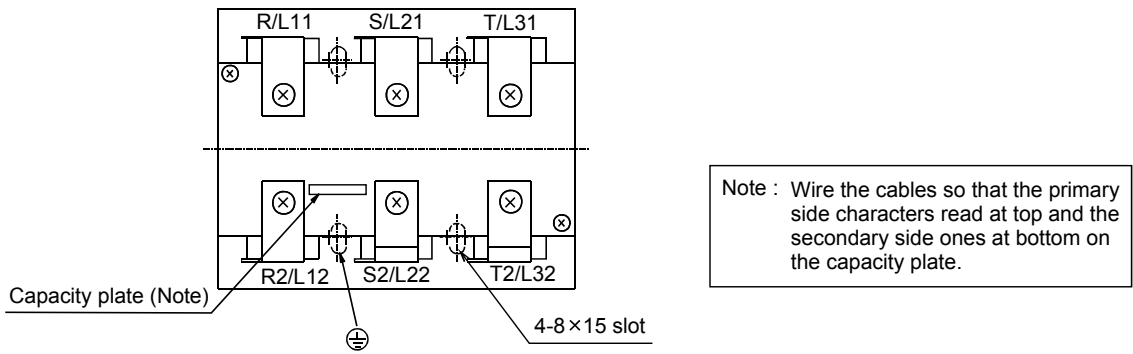

Reactor type	D	D1	Approximately weight (kg (lbs))
FR-CVL-7.5K	130 (5.12) maximum	82 (3.23)	4.5 (9.9)
FR-CVL-11K	130 (5.12) maximum	75 (2.95)	4.0 (8.8)
FR-CVL-15K	130 (5.12) maximum	105 (4.13)	5.5 (12.1)
FR-CVL-22K	140 (5.51) maximum	110 (4.33)	6.5 (14.3)

(Unit : mm (inches))

Standard Specifications

● FR-CVL-30K

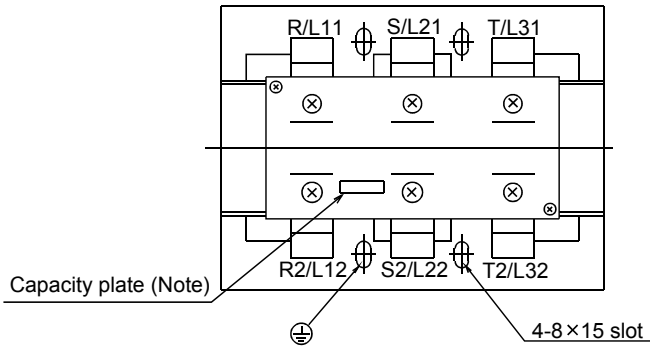

Note : Wire the cables so that the primary side characters read at top and the secondary side ones at bottom on the capacity plate.

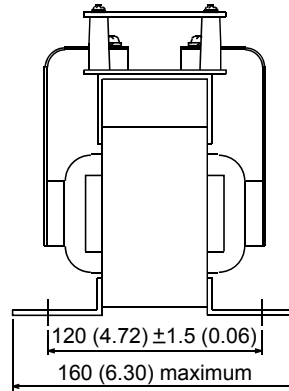
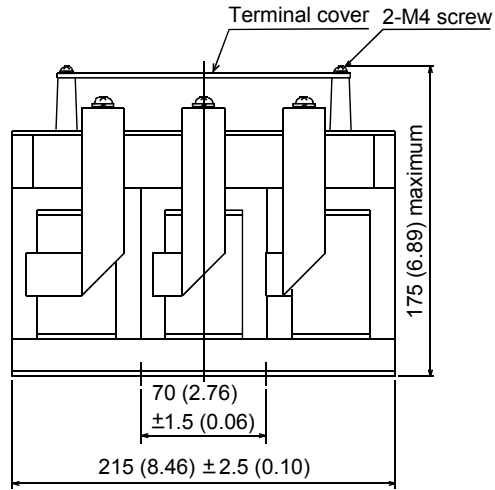

Approximately weight (kg (lbs))
11.0 (24.3)
(Unit : mm (inches))

● FR-CVL-37K/55K

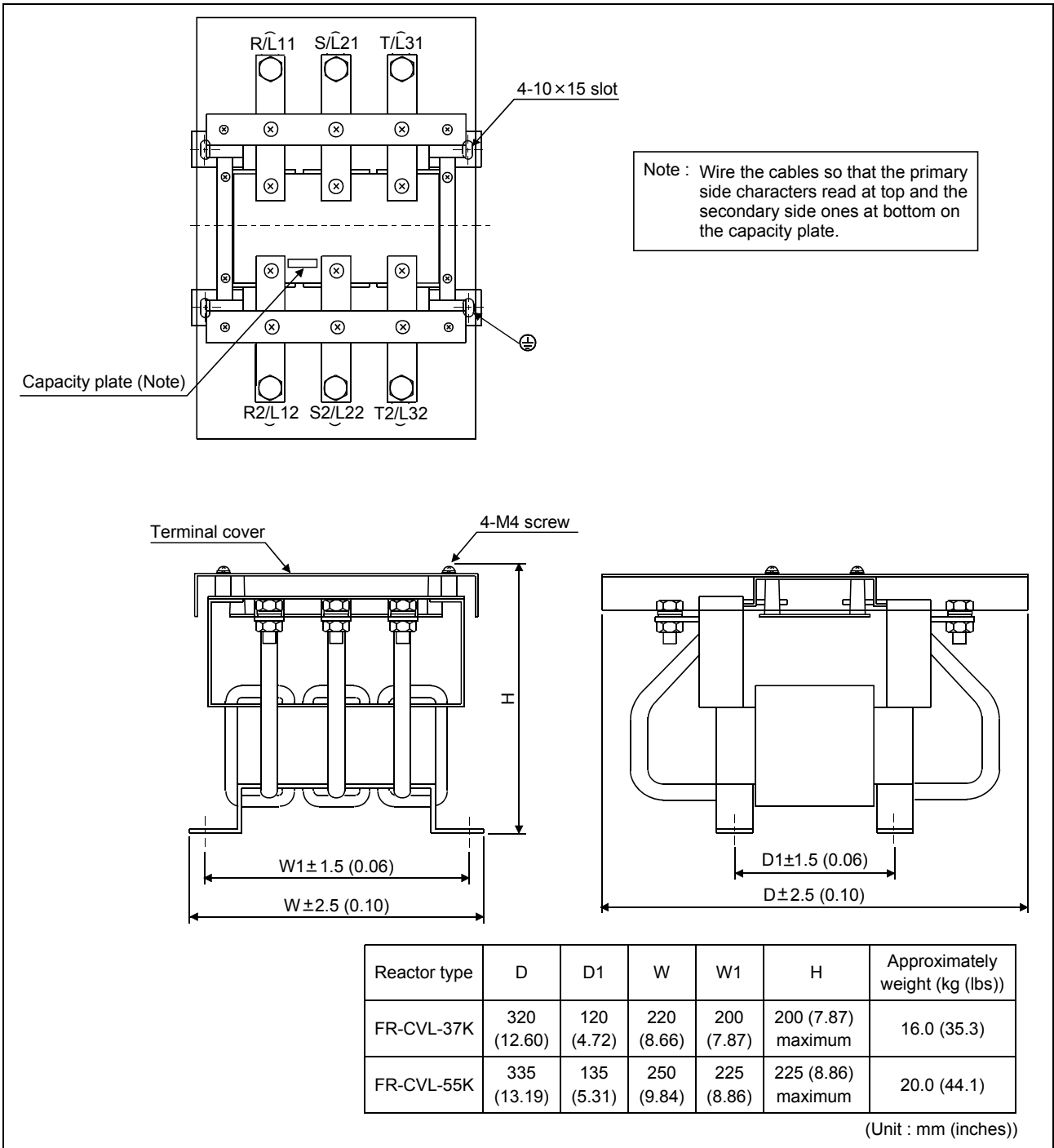

Standard Specifications

2) 400V class

● FR-CVL-H7.5K/H11K/H15K

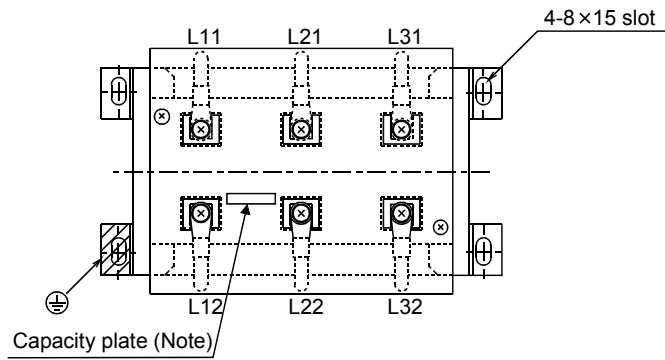

Note : Wire the cables so that the primary side characters read at top and the secondary side ones at bottom on the capacity plate.

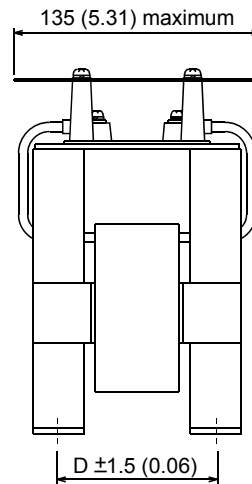
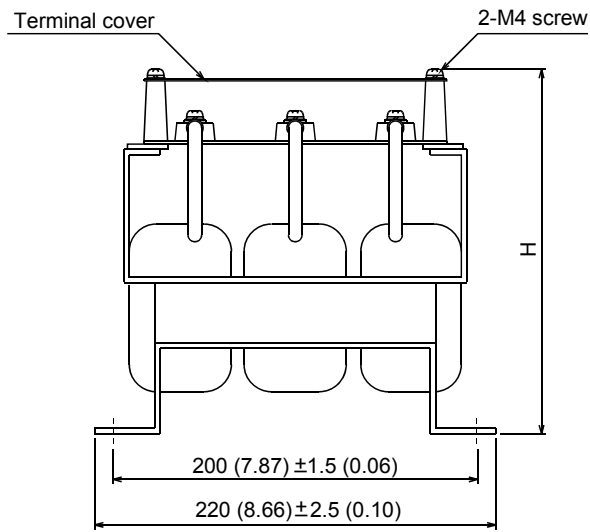

Reactor type	H	D	Approximately weight (kg (lbs))
FR-CVL-H7.5K	200 (7.87) maximum	88 (3.46)	7.0 (15.4)
FR-CVL-H11K	200 (7.87) maximum	98 (3.86)	7.5 (16.5)
FR-CVL-H15K	205 (8.07) maximum	98 (3.86)	8.0 (17.6)

(Unit : mm (inches))

● FR-CVL-H22K/H30K

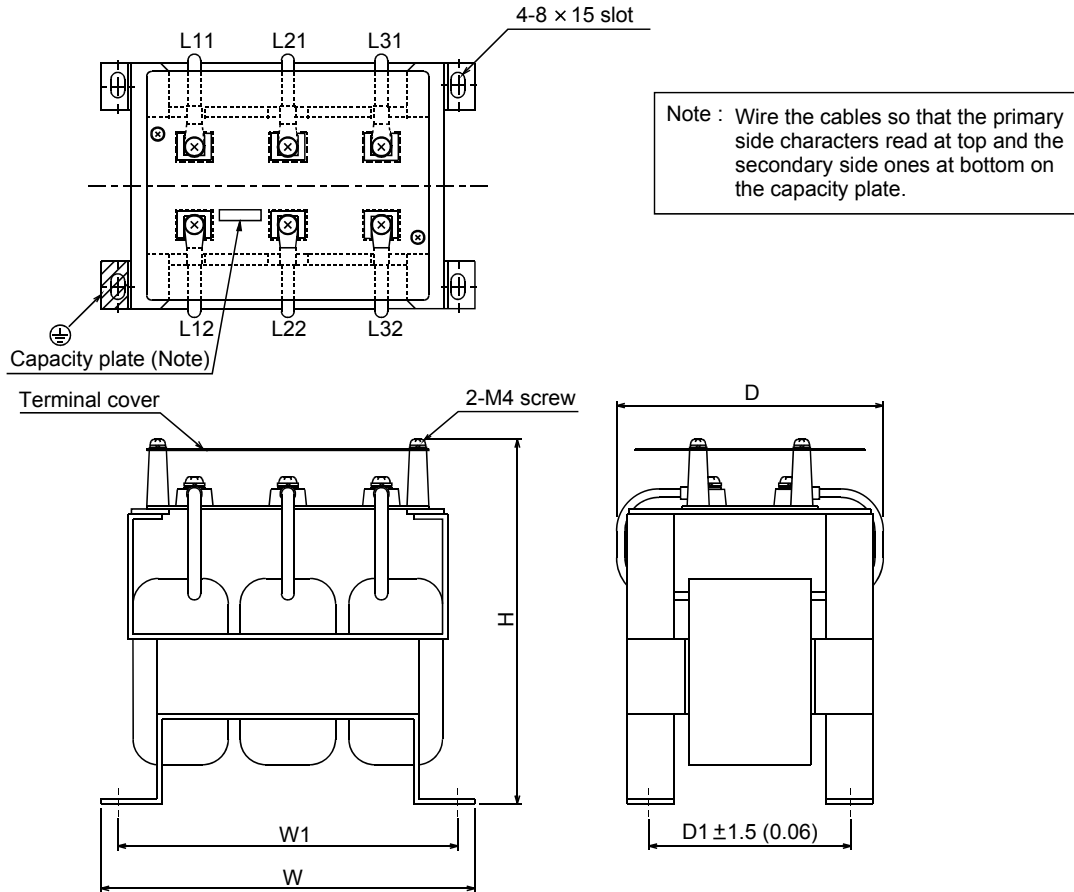

Reactor type	D	D1	W	W1	H	Approximately weight (kg (lbs))
FR-CVL-H22K	150 (5.91)	113 (4.45)	220 (8.66)	200 (7.87)	215 (8.46) maximum	10.5 (23.1)
FR-CVL-H30K	185 (7.28)	125 (4.92)	245 (9.65)	225 (8.86)	220 (8.66) maximum	12.0 (26.5)

(Unit : mm (inches))

Standard Specifications

● FR-CVL-H37K/H55K

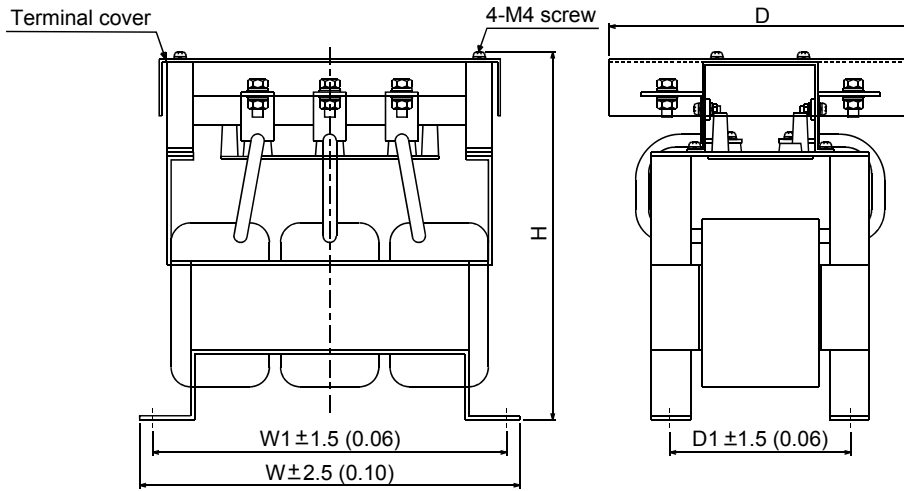
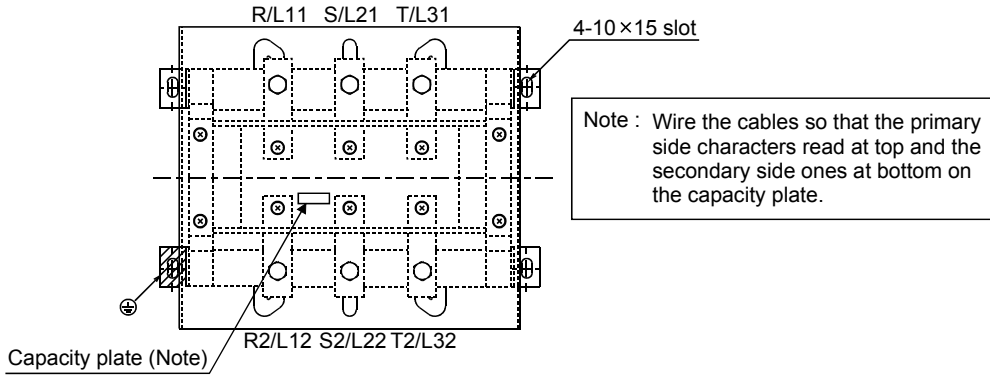

Reactor type	D	D1	W	W1	H	Approximately weight (kg (lbs))
FR-CVL-H37K	230 (9.06)	125 (4.92)	245 (9.65)	225 (8.86)	265 (10.43) maximum	16.0 (35.3)
FR-CVL-H55K	230 (9.06)	138 (5.43)	290 (11.42)	270 (10.63)	280 (11.02) maximum	22.5 (49.6)

(Unit : mm (inches))

MEMO

REVISIONS

* The manual number is given on the bottom left of the back cover.

Print Date	* Manual Number	Revision
Aug., 2001	IB(NA)-0600075-A	First edition
Jan., 2003	IB(NA)-0600075-B	<div data-bbox="544 309 676 340" style="border: 1px solid black; padding: 2px;">Additions</div> <ul style="list-style-type: none"> •Support the FR-V500, C500 and F500J. <div data-bbox="544 398 740 430" style="border: 1px solid black; padding: 2px;">Partial additions</div> <ul style="list-style-type: none"> •Wiring
Sep., 2008	IB(NA)-0600075-C	<div data-bbox="544 495 740 526" style="border: 1px solid black; padding: 2px;">Partial additions</div> <ul style="list-style-type: none"> •Note for terminal connection diagram •Instructions for installation

Additional notes for Instructions for UL and cUL

General precaution

CAUTION - Risk of Electric Shock -

The bus capacitor discharge time is 10 minutes. Before starting wiring or inspection, switch power off, wait for more than 10 minutes.

ATTENTION - Risque de choc électrique -

La durée de décharge du condensateur de bus est de 10 minutes. Avant de commencer le câblage ou l'inspection, mettez l'appareil hors tension et attendez plus de 10 minutes.