

4008 E / 4008 B / 4008 H / 4008 S

Hemodialysis system

Technical Manual

Edition: 5/03.09

Part no.: M40 618 1

Software 4.5/5.3 and higher



Caution!

These Operating Instructions in pdf-format are for information only.

They are not a replacement for the Operating Instructions supplied with the machine/device and options.



Fresenius Medical Care

Important information on the Technical Manual

How to use the Technical Manual

Identification	The document can be identified by the following information on the title page and on the labels, if any: <ul style="list-style-type: none">– Edition of the technical document– Part number of the technical document
Page identification	The page identification 1-3, for example, refers to: chapter 1, page 3.
Editorial information	The editorial information 1/01.05, for example, refers to the 1 st edition, January 2005.
Changes	Changes to the Technical Manual will be released as new editions or supplements. In general: This manual is subject to change without notice.
Significance of the safety precautions	Explanation of the Caution and Note symbols used:



Caution

Advises the operator against certain procedures or actions that could cause damage to the equipment or may have adverse effects on operators and patients.



Note

Informs the operator that if the steps are not followed as described, a specific function will be executed incorrectly or will not be executed at all, or will not produce the desired effect.

Important information on the system

Technician's qualification

Purpose	This Technical Manual is intended for service technicians and is to be used for first studies (to acquire a basic knowledge) and for reference purposes (for TSC, Maintenance and repair). The Technical Manual, however, does not replace the training courses offered by the manufacturer.
Requirements	Knowledge of the current Operating Instructions for the respective system. Background experience in mechanics, electrical and medical engineering.

Precautions for working on the system

Authorized persons	Assembly, extensions, adjustments, modifications or repairs may only be carried out by the manufacturer or persons authorized by him.
Test equipment and accessories	The activities described in this technical document require the availability of the necessary technical test equipment and accessories.
Specifications	For the specifications of the respective system, refer to the current Operating Instructions. Observe the information on the specifications.
Precautions	Before turning power on, repair any visible damage. Prior to opening the system and when working on the open system, the following precautions have to be observed: <ul style="list-style-type: none">– Protect the components against ingress of fluids.– Do not touch live parts (e.g. connectors of the power cable or heater).– Disconnect and connect all jacks, connectors and components only when the system is turned off.
ESD precautions	When repairing the system and replacing spare parts, observe the applicable ESD precautions.
Hygienic measures	The system and the consumables are generally considered to be contaminated and must therefore be sufficiently disinfected by the responsible organization as specified by the manufacturer.

Addresses

Please address any inquiries to:

Manufacturer Fresenius Medical Care AG & Co. KGaA
D-61346 Bad Homburg
+49 (0)6172-609-0
www.fmc-ag.com

**Service
Central Europe** Fresenius Medical Care
Deutschland GmbH
Geschäftsbereich Zentraleuropa
Kundendienst / Servicecenter
Steinmühlstraße 24
61352 Bad Homburg
Germany
Phone: +49 (0)6172-609-7100
Fax: +49 (0)6172-609-7102
E-mail: ServicecenterD@fmc-ag.com

**International
service** Fresenius Medical Care
Deutschland GmbH
Service Support International
Hafenstraße 9
D-97424 Schweinfurt
Germany
Phone: +49 (0)9721-678-333 (hotline)
Fax: +49 (0)9721-678-130

Local service



Table of contents

Section		Page
1	Description of system functions and malfunctions	1-
1.1	Description of the T1 test	1-3
1.2	Functional description of the modules	1-78
1.3	Functional description of the hydraulic unit	1-83
2	Technical Safety Checks / Maintenance	2-
2.1	Technical Safety Checks and Maintenance for 4008 hemodialysis systems and options	2-3
2.2	TSC report	2-25
3	Adjustment instructions	3-
3.1	Overview of the DIP switches in the 4008	3-9
3.2	Calibration mode	3-13
3.3	Hydraulics	3-15
3.4	Air detector	3-31
4	Calibration program	4-
5	Diagnostics program	5-
5.1	General notes	5-3
5.2	Menu structure	5-5
5.3	Reading the analog inputs of CPU I	5-7
5.4	Reading the analog inputs of CPU II	5-9
5.5	Reading the digital inputs of CPU I	5-10
5.6	Reading the digital inputs of CPU II	5-15
5.7	Writing the analog outputs of CPU I	5-19
5.8	Writing the analog outputs of CPU II	5-20
5.9	Writing the digital outputs of CPU I	5-21
5.10	Writing the digital outputs of CPU II	5-27
5.11	Writing/Reading the digital outputs of CPU I	5-30
5.12	ONLINE ^{plus} ™ module	5-31
5.13	HPU	5-32
6	Setup menu	6-
6.1	Overview Setup menu settings	6-3
6.2	Overview	6-7
6.3	Main menu 4008 E/B	6-9
6.4	Main menu 4008 H/S	6-37
7	Miscellaneous	7-

Section		Page
8	Circuit diagrams and circuit descriptions	8-
8.1	Block diagram 4008	8-3
8.2	Block diagram of voltage supply	8-4
8.3	Block diagram of screen 4008 H/S	8-5
8.4	Connection layout diagram	8-6
8.5	P.C.B. LP 450-2 Level detector control (LD)	8-9
8.6	P.C.B. LP 493 Blood leak detector	8-11
8.7	P.C.B. LP 624 Control board (BP)	8-12
8.8	P.C.B. LP 630 Motherboard	8-13
8.9	P.C.B. LP 631 CPU 1	8-14
8.10	P.C.B. LP 632 CPU 2	8-16
8.11	P.C.B. LP 633 Input board	8-18
8.12	P.C.B. LP 634 Output board	8-20
8.13	P.C.B. LP 635 Display board	8-22
8.14	P.C.B. LP 636 External connectors	8-24
8.15	P.C.B. LP 950 Control board (HEP)	8-25
8.16	P.C.B. LP 644-4 Display board (HEP)	8-26
8.17	P.C.B. LP 645 Position sensor membrane pump	8-27
8.18	P.C.B. LP 649-2 Display board (4008 B/S)	8-28
8.19	P.C.B. LP 742 Interference filter	8-30
8.20	P.C.B. LP 748 Display board (BP)	8-31
8.21	P.C.B. LP 763 Multi interface board (COMMCO III)	8-32
8.22	P.C.B. LP 922 Display board (4008 S)	8-33
8.23	P.C.B. LP 923 Traffic light (4008 H/S)	8-34
8.24	P.C.B. LP 924 Display board (4008 H)	8-35
8.25	P.C.B. LP 941 Hydraulics processor	8-36
8.26	Heater board (power supply unit 4008)	8-37
8.27	Power board (power supply unit 4008)	8-38

Table of contents

1 Description of system functions and malfunctions

Section		Page
1.1	Description of the T1 test	1-3
1.1.1	T1 test flow diagram, serial program steps	1-3
1.1.2	T1 test flow diagram, parallel program steps	1-5
1.1.3	Description of the T1 test incl. error messages	1-7
1.1.4	Description of system errors during the cleaning programs	1-53
1.1.5	Error messages after turning power on	1-70
1.1.6	Error messages during dialysis	1-71
1.2	Functional description of the modules	1-78
1.2.1	Blood pump (arterial)	1-78
1.2.2	Blood pump (Single-Needle), optional	1-79
1.2.3	Heparin pump	1-80
1.2.4	Air detector	1-82
1.3	Functional description of the hydraulic unit	1-83
	<i>Fig.: Flow diagram</i>	1-83
1.3.1	Description of the hydraulic unit	1-85
1.3.2	Theory of operation of the balancing chamber	1-87
1.3.3	Central delivery system option	1-91
1.3.4	Program sequences during the cleaning programs	1-92
	<i>Fig.: Flow chart of cleaning programs – overview</i>	1-92

1.1 Description of the T1 test

1.1.1 T1 test flow diagram, serial program steps

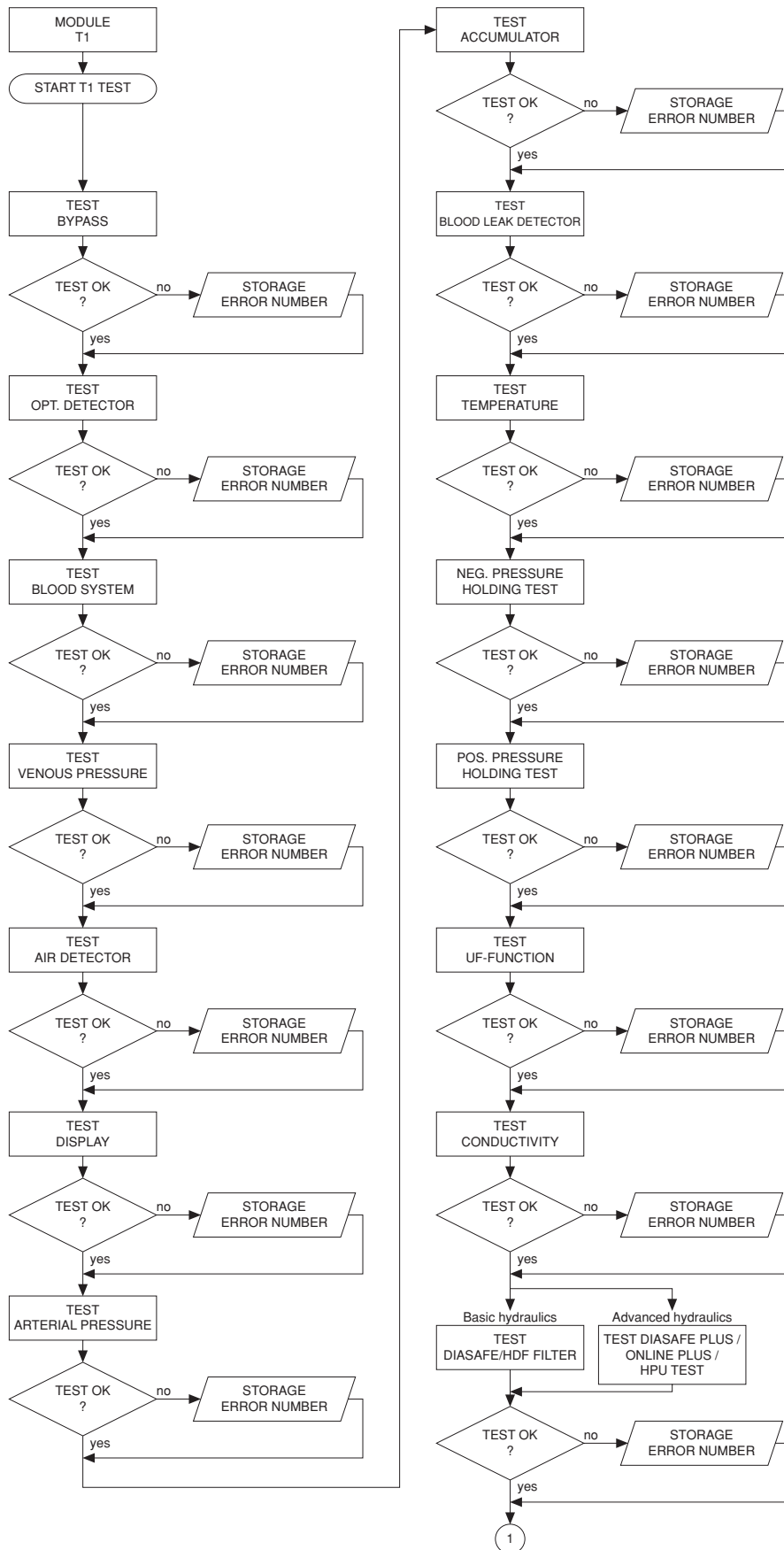

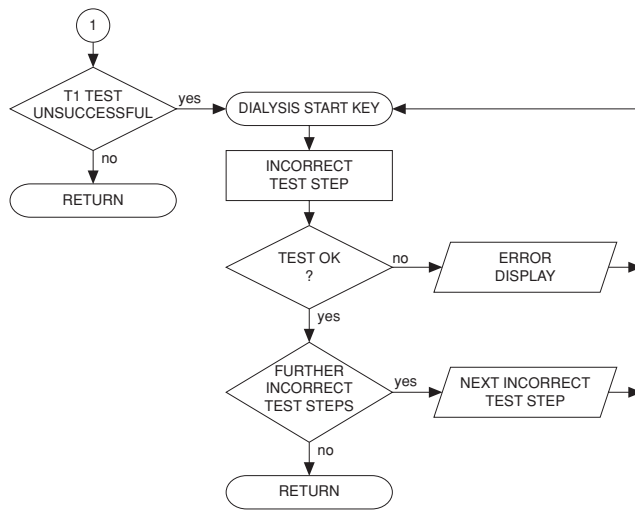

1.1.2 T1 test flow diagram, parallel program steps

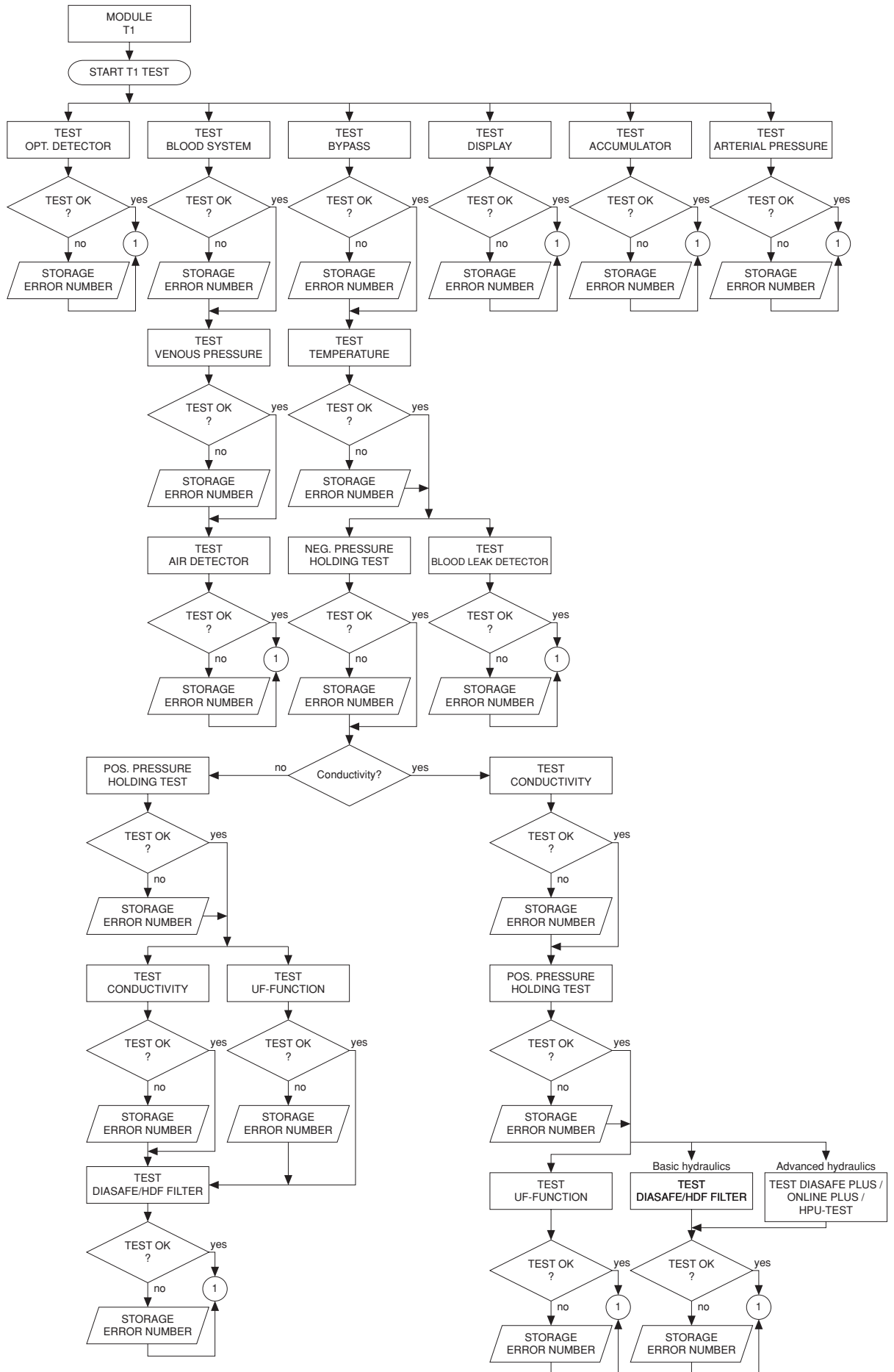

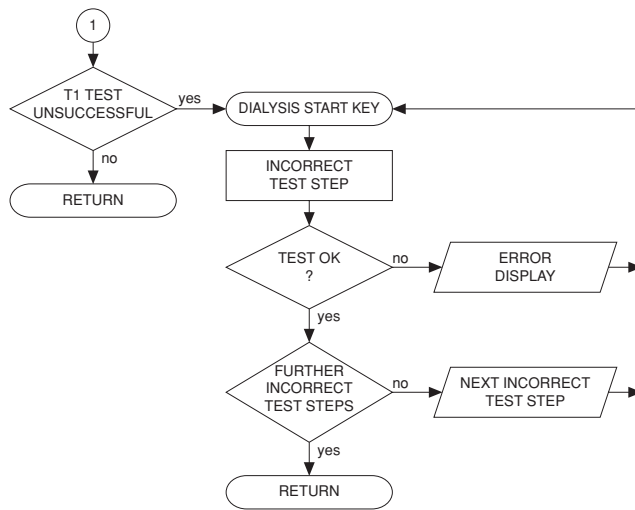

1.1.3 Description of the T1 test incl. error messages

- Prerequisites for starting and running the test

<i>Error message</i>	<i>Description</i>
Power failure	Power failure while the test is in progress
Dialines not conn	The dialysate lines are not in the interlock shunt.
Shunt Cover open	The interlock shunt is open.
Connect Conc.Line Wrong conc. supply	The concentrate connector is in the rinse chamber, or concentrate is not connected at all. The error message depends on the central delivery system preselected in the setup menu.
Blood Sensed by OD	The optical detector senses blood in the system.
Flow alarm	Line to or from the dialyzer kinked, malfunctions in the hydraulics.
Water alarm	Water supply interrupted.
XXX not calibrated	A valid calibration value is missing in the NOVRAM.

- Overview of the individual test steps

Bypass test	1-8
Optical detector test	1-10
Blood system test	1-12
Venous pressure system test	1-16
Air detector test	1-18
Display test	1-22
Arterial pressure system test	1-24
Battery test	1-26
Blood leak test	1-28
Temperature test	1-30
Negative pressure holding test	1-32
Positive pressure holding test	1-34
UF function test	1-39
Conductivity test	1-42
Diasafe/HDF filter test	1-44
Online plus / Diasafe plus filter / HPU test	1-48

- Bypass test

Test description:

Check of the following functions:

- Heater relay
- Bypass (electric)
- Check of the temperature range changeover

Illustration:

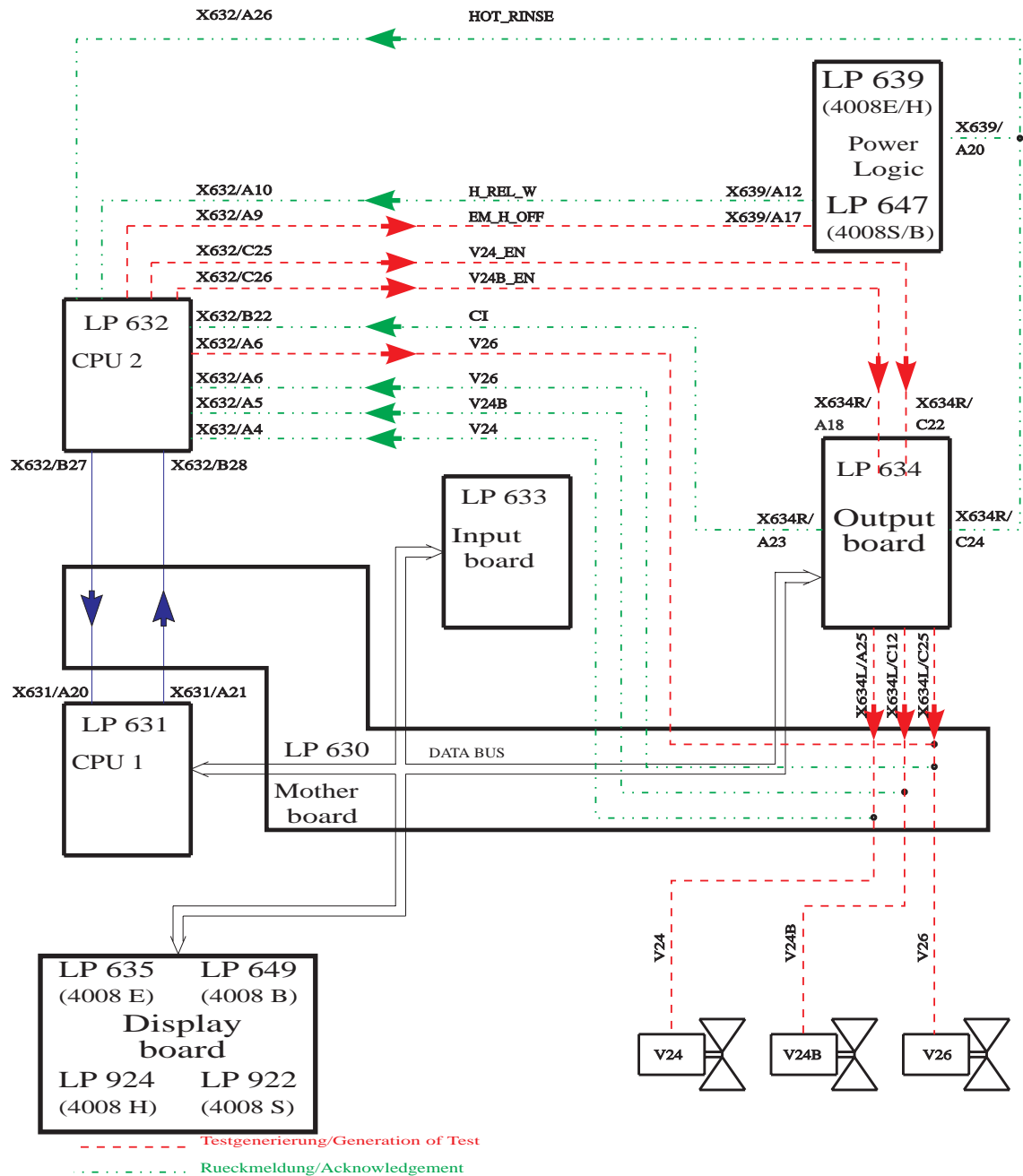

Error description:

<i>Error message</i>	<i>Description</i>
F 01 Bypass	The heater relay is switched off. <ul style="list-style-type: none">– Acknowledgement (H_REL_W, X639/A12) → X632/A10, 0 V are missing.
F 02 Bypass	The heater relay cannot be switched off by CPU2. <ul style="list-style-type: none">– Acknowledgement (H_REL_W, X639/Y12) → X632/A10, 12 V are missing.– Control line (EM_H_OFF, X632/A9) → X639/A17, 12 V are missing.
F 03 Bypass	The temperature measurement range is set to hot rinse. <ul style="list-style-type: none">– Control line (HOTRINSE, X634R/C24) → X639/A20, 0 V are missing.– Acknowledgement (HOTRINSE, X634R/C24) → X632/A26, 0 V are missing.
F 04 Bypass	The extended bypass cannot be correctly switched by CPU2 (V24 = off, V26 = on, V24B = off). <ul style="list-style-type: none">– Acknowledgement (V24, X637/C1) → X632/A4, 24 V are missing.– Acknowledgement (V26, X637/C2) → X632/A6, 0 V are missing.– Acknowledgement (V24B, X637/C23) → X632/A5, 24 V are missing.
F 05 Bypass	The extended bypass cannot be correctly switched off by CPU2 (V24 = on, V26 = off, V24B = on). <ul style="list-style-type: none">– Acknowledgement (V24, X637/C1) → X632/A4, 0 V are missing.– Acknowledgement (V26, X637/C2) → X632/A6, 24 V are missing.– Acknowledgement (V24B, X637/C23) → X632/A5, 0 V are missing.
F06 Bypass	CPU1 fails to set the temperature control to hot rinse. <ul style="list-style-type: none">– Control line (HOTRINSE, X634R/C24) → X639/A20, 12 V are missing.– Acknowledgement (HOTRINSE, X634R/C24) → X632/A26, 12 V are missing.
F 07 Bypass	The extended bypass cannot be correctly switched by CPU1 (V24 = off, V26 = on, V24B = off). <ul style="list-style-type: none">– Acknowledgement (V24, X637/C1) → X632/A4, 24 V are missing.– Acknowledgement (V26, X637/C2) → X632/A6, 0 V are missing.– Acknowledgement (V24B, X637/C23) → X632/A5, 24 V are missing.
F08 Bypass	CPU1 fails to reset the temperature control to dialysis. <ul style="list-style-type: none">– Control line (HOTRINSE, X634R/C24) → X639/A20, 0 V are missing.– Acknowledgement (HOTRINSE, X634R/C24) → X632/A26, 0 V are missing.
F09 Bypass	The extended bypass cannot be correctly switched off by CPU1 (V24 = on, V26 = off, V24B = on). <ul style="list-style-type: none">– Acknowledgement (V24, X637/C1) → X632/A4, 0 V are missing.– Acknowledgement (V26, X637/C2) → X632/A6, 24 V are missing.– Acknowledgement (V24B, X637/C23) → X632/A5, 0 V are missing.
F95 Bypass	System error

- **Optical detector test**

Test description:

Attenuation of the optical detector.
 Check of the acknowledgement of the optical detector.

Illustration:

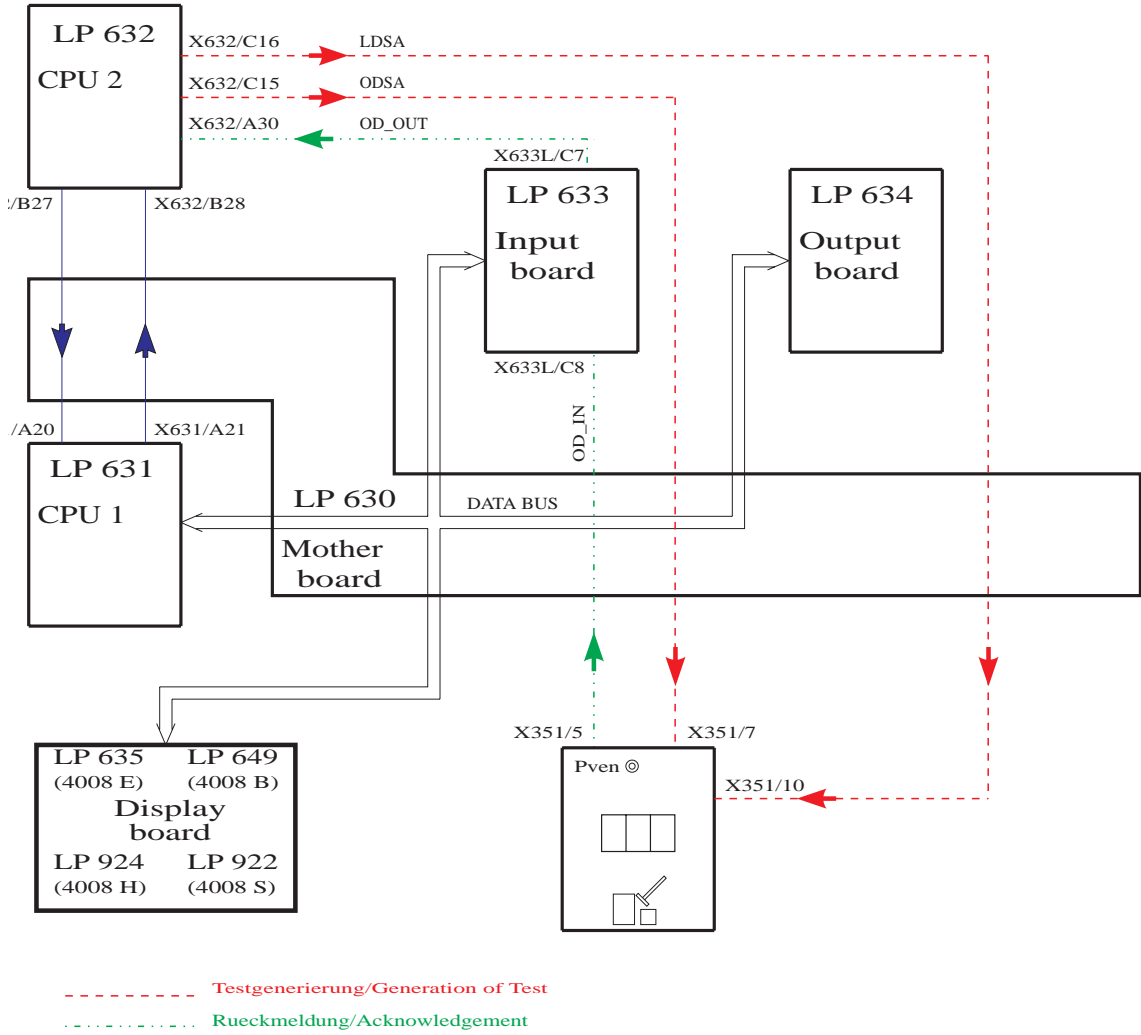

Error description:

<i>Error message</i>	<i>Description</i>
F01 opt. Detector	CPU1 interprets the optical detector in a different way than does CPU2. – Acknowledgement (OD_OUT, X633L/C7) → X632/A30 and the digital input of P.C.B. LP 633 measure different levels.
F02 opt. Detector	CPU2 fails to recognize blood in the system. – Acknowledgement (OD_OUT, X633L/C7) → X632/A30, 0 V are missing. – Detuning (ODSA, X632/C15) → X351/7 not 12V.
F03 opt. Detector	CPU1 fails to recognize blood in the system. – Acknowledgement (OD_OUT, X633L/C7) → digital input on P.C.B. LP 633. – Detuning (ODSA, X632/C15) → X351/7 not 12V.
F04 opt. Detector	CPU2 recognizes that the optical detector senses opaque fluid (required because of the test in the cleaning program). – Acknowledgement X632/A30 not 12V. – AD28 defective.
F96 opt. Detector	System error.

- Blood system test

Test description:

- Check of the following functions:
- Blood alarm acknowledgement
 - Blood pump switch-off

Illustration:

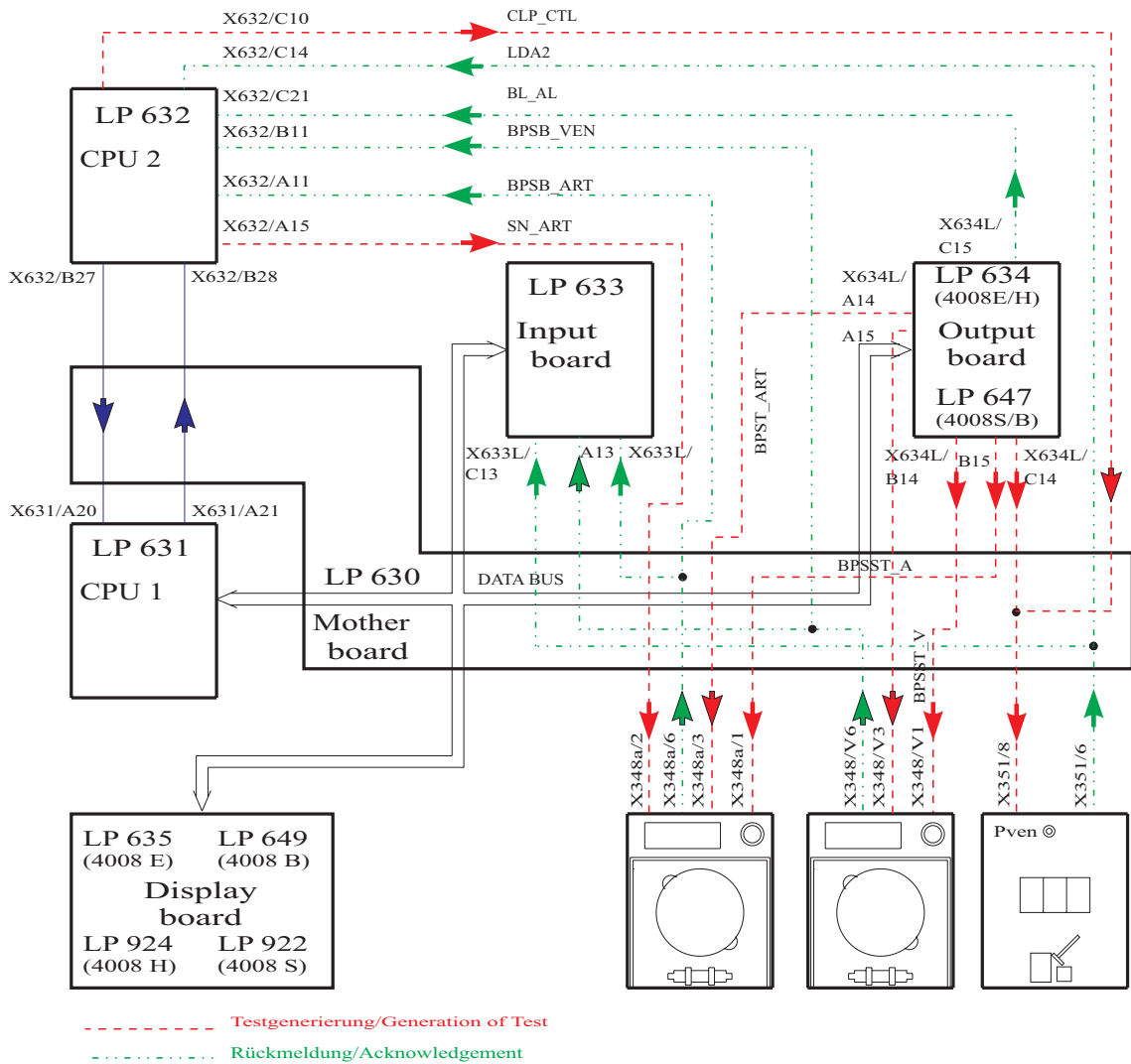

Error description:

Error message

Description

F09 Bloodsystem

Acknowledgement that CPU2 recognizes that the arterial blood pump is inactive (BP not running).

- Acknowledgement (BPSB_ART, X348a/6) → X632/A11, 12 V missing.
- Control line (BPSST_ART, X634L/B14) → X348a/1, 12 V missing or (BPST_ART, X634L/A14) → X348a/3, 12 V are missing.

F10 Bloodsystem

Acknowledgement that CPU1 recognizes that the arterial blood pump is inactive (BP not running).

- Acknowledgement (BPSB_ART, X348a/6) → X633L/A11, 12 V are missing.
- Control line (BPSTT_ART, X634L/B14) → X348a/1, 12 V missing or (BPST_ART, X634L/A14) → X348a/3, 12 V missing.
- Level is raised during the T1 test.

F11 Bloodsystem

The arterial blood pump cannot be stopped by CPU1.

CPU2 recognizes that the arterial blood pump remains active.

- Control line (BPSST_ART, X634L/B14) → X348a/1, 0 V missing, as well as (BPST_ART, X634L/A14) → X348a/3, 0 V missing.
- Acknowledgement (BPSB_ART, X348a/6) → X632/A11, 0 V are missing.
- The level is raised during the T1 test, or the up/down key on the air detector is blocked and the level is constantly raised.

F12 Bloodsystem

The arterial blood pump cannot be stopped by CPU1.

CPU1 recognizes that the arterial blood pump remains active.

- Control line (BPSST_A, X634L/B14) → X348a/1, 0 V missing, as well as (BPST_ART, X634L/A14) → X348a/3, 0 V missing.
- Acknowledgement (BPSB_ART, X348a/6) → X633L/A11, 0 V are missing.

F13 Bloodsystem

Applicable for SW 4.91/2.91 and higher if SN, ONLINE-HDF or 4008 HDF pump is connected (= ADKS active)

Acknowledgement that CPU2 detects that the pump is inactive (pump is not running).

- Acknowledgement (BPSB_VEN, X348V/6) → X632/ B11, 12V missing
- Control line (BPSST_VEN, X634L/B15) → X348V/1, 12V missing or (BPST_VEN, X634L/A15) → X348V/3, 12V missing
- Transistor T9 on P.C.B. LP 754 defective
- IC5 on P.C.B. LP 632 defective
- In 4008 HDF an HDF treatment was performed, followed by a cleaning program with the substitute pump running, then the T1 test has been re-started.

The substitute pump must be switched off because otherwise the test step will fail to be passed (problem was corrected with SW 3.20 in 4008 H/S systems: the substitute pump will be switched off automatically on starting a cleaning program).

F14 Bloodsystem

Applicable for SW 4.91/2.91 and higher if SN, ONLINE-HDF or 4008 HDF pump is connected (= ADKS active)

Acknowledgement that CPU1 detects that the pump is inactive (pump is not running).

- Acknowledgement (BPSB_VEN, X348V/6) → X633L/A13, 12V missing
- Control line (BPSST_VEN, X634L/B15) → X348V/1 not 12V or (BPST_VEN, X634L/A15) → X348V/3 not 12V
- IC16 on P.C.B. LP 633 defective
- P.C.B. LP 633 recognizes Single-Needle pump although it is not connected.

F15 Bloodsystem

Applicable for SW 4.91/2.91 and higher if SN, ONLINE-HDF or 4008 HDF pump is connected (= ADKS active)

CPU1 fails to stop the corresponding blood pump.

CPU2 detects that the pump remains active.

- Control line (BPSST_VEN, X634L/B15) → X348V/1, 0V missing as well as (BPST_VEN, X634L/A15) → X348V/3 not 0V
- Acknowledgement (BPSB_VEN, X348V/6) → X632/B11, 0V missing
- Transistor T9 on P.C.B. LP 754 defective
- IC5 on P.C.B. LP 632 defective
- During the test the lines are inserted on the corresponding pump using the Start/Stop key.
- P.C.B. LP 633 recognizes Single-Needle pump although it is not connected.

F16 Bloodsystem

Applicable for SW 4.91/2.91 and higher if SN, ONLINE-HDF or 4008 HDF pump is connected (= ADKS active)

CPU1 fails to stop the corresponding blood pump.

CPU1 detects that the pump remains active.

- Control line (BPSST_VEN, X634L/B15) → X348V/1 not 0V as well as (BPST_VEN, X634L/A15) → X348V/3 not 0V
- Acknowledgement (BPSB_VEN, X348V/6) → X633L/A13 not 0V
- IC16 on P.C.B. LP 633 defective
- P.C.B. LP 633 recognizes Single-Needle pump although it is not connected.

F17 Bloodsystem

Applicable for SW 4.91/2.91 and higher if SN, ONLINE-HDF or 4008 HDF pump is connected (= ADKS active)

Although the recognition of the venous blood pump (ADKS) is not acknowledged, the 24-V supply voltage of the pump can be switched off.

- Acknowledgement line (ADKS, X348V/7) → X633L/A10 not 12V
- Acknowledgement (BPSB_VEN, X348V/6) → X633L/A13 not 12V
- Acknowledgement (BPSB_VEN, X348V/6) → X632/B11 not 12V
- Online-HDF has already been switched on during the T1 test.
- IC16 on P.C.B. LP 633 defective.

F18 Bloodsystem	<p><i>Applicable for SW 5.00/4.10 and higher, check of the BPUS signal (CPU, P.C.B. LP 632)</i></p> <p>At the beginning of the test step a maximum of 40s may pass until rotation has stopped. If the blood pump is being activated, the rotation stop alarm must have been cleared.</p> <ul style="list-style-type: none"> - Acknowledgement line (BPUS, X348A/8) → X632/A13 not 0V - Acknowledgement line (BPUS, X348A/8) → X632/A13 not 12V - Blood pump speed is set to "0": preset speed during the T1 test.
F19 Bloodsystem	<p><i>Applicable for SW 5.00/4.10 and higher, check of the BPUS signal (CPU, P.C.B. LP 631 via LP 633)</i></p> <p>At the beginning of the test step a maximum of 40s may pass until rotation has stopped. If the blood pump is being activated, the rotation stop alarm must have been cleared.</p> <ol style="list-style-type: none"> 1. Acknowledgement line (BPUS, X348A/8) → X633L/A12 not 0V 2. Acknowledgement line (BPUS, X348A/8) → X633L/A12 not 12V
F20 Bloodsystem	<p>Check of the actual arterial BP rate.</p> <p>The actual rate of the arterial BP is not zero. The actual rate of the arterial BP does not increase.</p> <p>If SN is installed: The actual rate of the venous BP is not zero. The actual rate of the venous BP does not increase.</p> <ul style="list-style-type: none"> - Acknowledgement line (BPR_ART, X348A/10) → X633L/B3 not 0V or acknowledgement line (BPR_ART, X348A/10) → X632/A14 not 0V - Acknowledgement line (BPR_ART, X348A/10) → X633L/B3 no increase or acknowledgement line (BPR_ART, X348A/10) → X632/A14 no increase <p>If SN is installed:</p> <ul style="list-style-type: none"> - Acknowledgement line (BPR_VHDF, X348V/10) → X633L/B4 not 0V - Acknowledgement line (BPR_VHDF, X348V/10) → X633L/B4 no increase
F95 Bloodsystem	<p>System error.</p>

- Venous pressure system test

Test description:

Verification of the lower limit by checking the venous zero point.
 The upper limit is tested by detuning the venous pressure unit in positive direction.
 (The venous line clamp is closed during the test.)

Illustration:

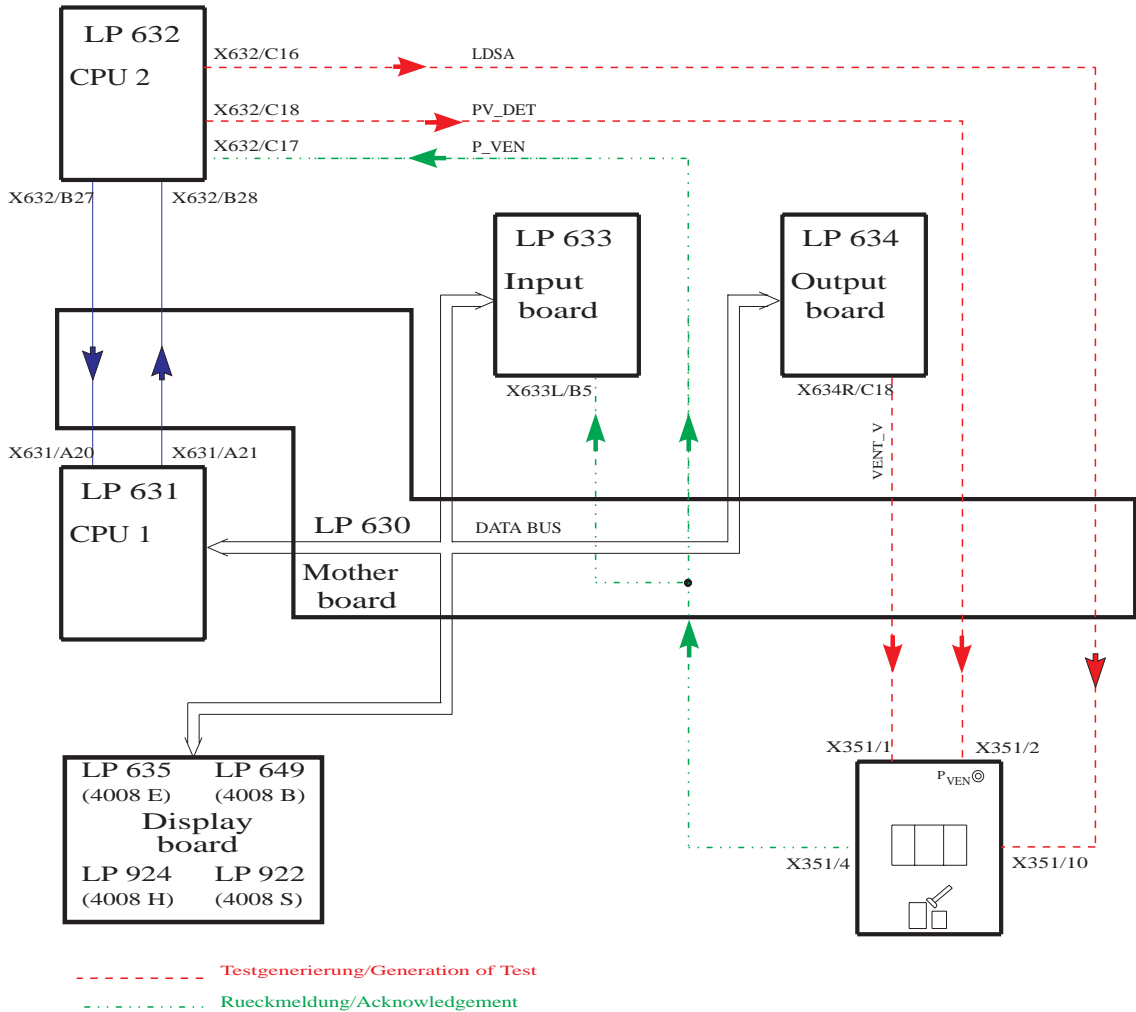

Error description

<i>Error message</i>	<i>Description</i>
F01 Venous	<p>CPU1 (input board) shows a venous zero point deviation of more than ± 12 mmHg (60 s).</p> <ul style="list-style-type: none">– Control (VENT_VALVE, X634R/C18) → X351/1 of the vent valve in the LD is defective.– Acknowledgement (P_VEN, X351/4) → X633L/B5 that the voltage value is outside the zero point tolerance.– P-venous has not been calibrated.
F02 Venous	<p>CPU2 shows a venous zero point deviation of more than ± 12 mmHg (60 s).</p> <ul style="list-style-type: none">– Control (VENT_VALVE, X634R/C18) → X351/1 of the vent valve in the LD is defective.– Acknowledgement (P_VEN, X351/4) → X632/C17, the voltage value is outside the zero point tolerance.– P-venous has not been calibrated.
F03 Venous	<p>With detuning in positive direction, the achieved change in the venous display is less than 100 mmHg (7 s).</p> <ul style="list-style-type: none">– The test detuning is defective (PV_DET, X632/C18) → X351/2.– Acknowledgement (P_VEN, X351/4) → X633L/B5, the change in voltage is too low.– P-venous has not been calibrated.
F04 Venous	<p>The deviation in the measured value between CPU1 and CPU2 is higher than ± 12 mmHg (if Pven > 100 mmHg).</p> <ul style="list-style-type: none">– Acknowledgement (P_VEN, X351/4) → X633L/B5 and X632/C17 measure different voltage values.– P-venous has not been calibrated.
F95 Venous	<p>System error.</p>

- Air detector test

Test description:

- Test of the air detector by checking the alarm state.
- Switch-off of the venous line clamp in the air detector module.

Illustration:

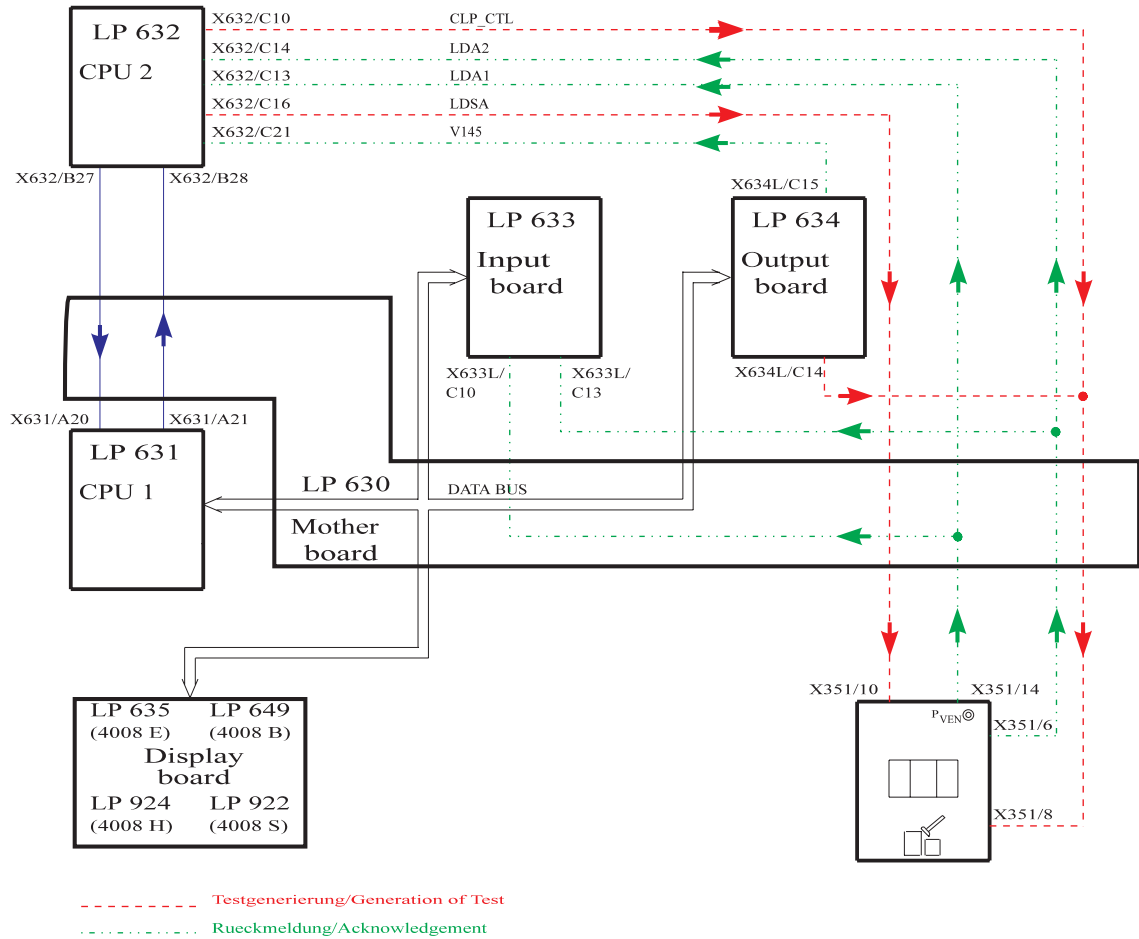

Error description:

<i>Error message</i>	<i>Description</i>
F01 Airdetector	<p>CPU1 interprets the air detector signal in a different way than does CPU2.</p> <ul style="list-style-type: none">– Acknowledgements (LDA1, X351/14) → X632/C13 and X633L/C10 recognize different signal levels.
F02 Airdetector	<p>The air detector alarm is not recognized by CPU2.</p> <ul style="list-style-type: none">– Acknowledgement (LDA1, X351/14) → X632/C13, 0 V are missing.– Transmission weakening (LDSA, X632/C16) → X351/10, 12 V are missing.
F03 Airdetector	<p>Air detector clamps acknowledgement (CPU2) activated (clamp closed).</p> <ul style="list-style-type: none">– Acknowledgement (LDA2, X351/6) → X632/C14, 24 V are missing.– Clamp control (CLP_CTL, X634L/C14) → X351/8, 12 V are missing.– Clamp control (CLP_CTL, X632/C10) → X351/8, 12 V are missing.
F04 Airdetector	<p>Air detector clamps acknowledgement (CPU1) activated (clamp closed).</p> <ul style="list-style-type: none">– Acknowledgement (LDA2, X351/6) → X633L/C13, 24 V are missing.– Clamp control (CLP_CTL, X634L/C14) → X351/8, 12 V are missing.– Clamp control (CLP_CTL, X632/C10) → X351/8, 12 V are missing.
F05 Airdetector	<p>The blood alarm signal has not been cleared (indicates an alarm).</p> <ul style="list-style-type: none">– Acknowledgement (BL_AL, X634L/C15) → X632/C21, 12 V are missing. <p>If the HDF option is used, this signal is not tested (special function).</p>
F06 Airdetector	<p>Closing of the air detector clamp via the CPU2 control line was not possible.</p> <ul style="list-style-type: none">– Clamp control (CLP_CTL, X632/C10) → X351/8, 0 V are missing.– Acknowledgement (LDA2, X351/6) → X632/C14, 0 V are missing.
F07 Airdetector	<p>Opening of the air detector clamp via the CPU2 control line was not possible.</p> <ul style="list-style-type: none">– Clamp control (CLP_CTL, X632/C10) → X351/8, 12 V are missing.– Acknowledgement (LDA2, X351/6) → X632/C14, 24 V are missing.
F08 Airdetector	<p>Closing of the air detector clamp via the CPU1 control line was not possible, or CPU2 acknowledgement is incorrect.</p> <ul style="list-style-type: none">– Clamp control (CLP_CTL, X634L/C14) → X351/8, 0 V are missing.– Acknowledgement (LDA2, X351/6) → X632/C14, 0 V are missing.

- F09 Airdetector** Closing of the air detector clamp via the CPU1 control line was not possible, or CPU1 acknowledgement is incorrect.
- Clamp control (CLP_CTL, X634L/C14) → X351/8, 0 V are missing.
 - Acknowledgement (LDA2, X351/6) → X633L/C13, 0 V are missing.
- F10 Airdetector** The blood alarm message is missing.
- Acknowledgement (BL_AL, X634R/C15) → X632/C21, 0 V are missing.
- If the HDF option is used, this signal is not tested (special function).
- F11 Airdetector** Air detector clamps acknowledgement (CPU2) activated (clamp closed).
- Acknowledgement (LDA2, X351/6) → X632/C14, 24 V are missing.
 - Clamp control (CLP_CTL, X634L/C14) → X351/8, 12 V are missing.
 - Clamp control (CLP_CTL, X632/C10) → X351/8, 12 V are missing.
- F12 Airdetector** Air detector clamps acknowledgement (CPU1) activated (clamp closed).
- Acknowledgement (LDA2, X351/6) → X633L/C13, 24 V are missing.
 - Clamp control (CLP_CTL, X634L/C14) → X351/8, 12 V are missing.
 - Clamp control (CLP_CTL, X632/C10) → X351/8, 12 V are missing.
- F13 Airdetector** The blood alarm signal has not been cleared (indicates alarm).
- Acknowledgement (BL_AL, X634L/C15) → X632/C21, 12 V are missing.
- If the HDF option is used, this signal is not tested (special function).
- F14 Airdetector** Raise level key on the air detector is constantly active.
- Acknowledgement (LEVEL_UP, X351/3) → X632/C11 not 0V.
- F15 Airdetector** Acknowledgement of the supply voltage for the ultrasonic output stage not between 6.5 and 13.5 V after 3 seconds.
- Adapter board AD28 not connected
 - Acknowledgement (X351/11 → X633L/25A jumper to X633L/B7) not 12V.
 - Relay on AD28 failed to drop.
- F16 Airdetector** Acknowledgement of the supply voltage for the ultrasound output stage not >14.5V after 3 seconds.
- Adapter board AD28 not connected.
 - Acknowledgement (X351/11 → X633L/25A jumper to X633L/B7) not 16V/24V.
 - Relay on AD28 is not controlled.
 - No 10-Hz signal at ALARM_REST (X351/12)

F17 Airdetector

Acknowledgement of the supply voltage for the ultrasound output stage not between 6.5 and 13.5 V after 3 seconds.

- Adapter board AD28 not connected
- Acknowledgement (X351/11 → X633L/25A jumper to X633L/B7) not 12V
- Relay on AD28 failed to drop

F95 Airdetector

System error.

- **Display test**

Test description:

Check of all displays and indicators on the monitor front

- Display test
- Status LED
- Alarm LED
- Seven-segment display, all dark
- Seven-segment display, all 8888
- Bar graph
- CPU1/CPU2 alarm tone

This display test must be monitored by the user!

Illustration:

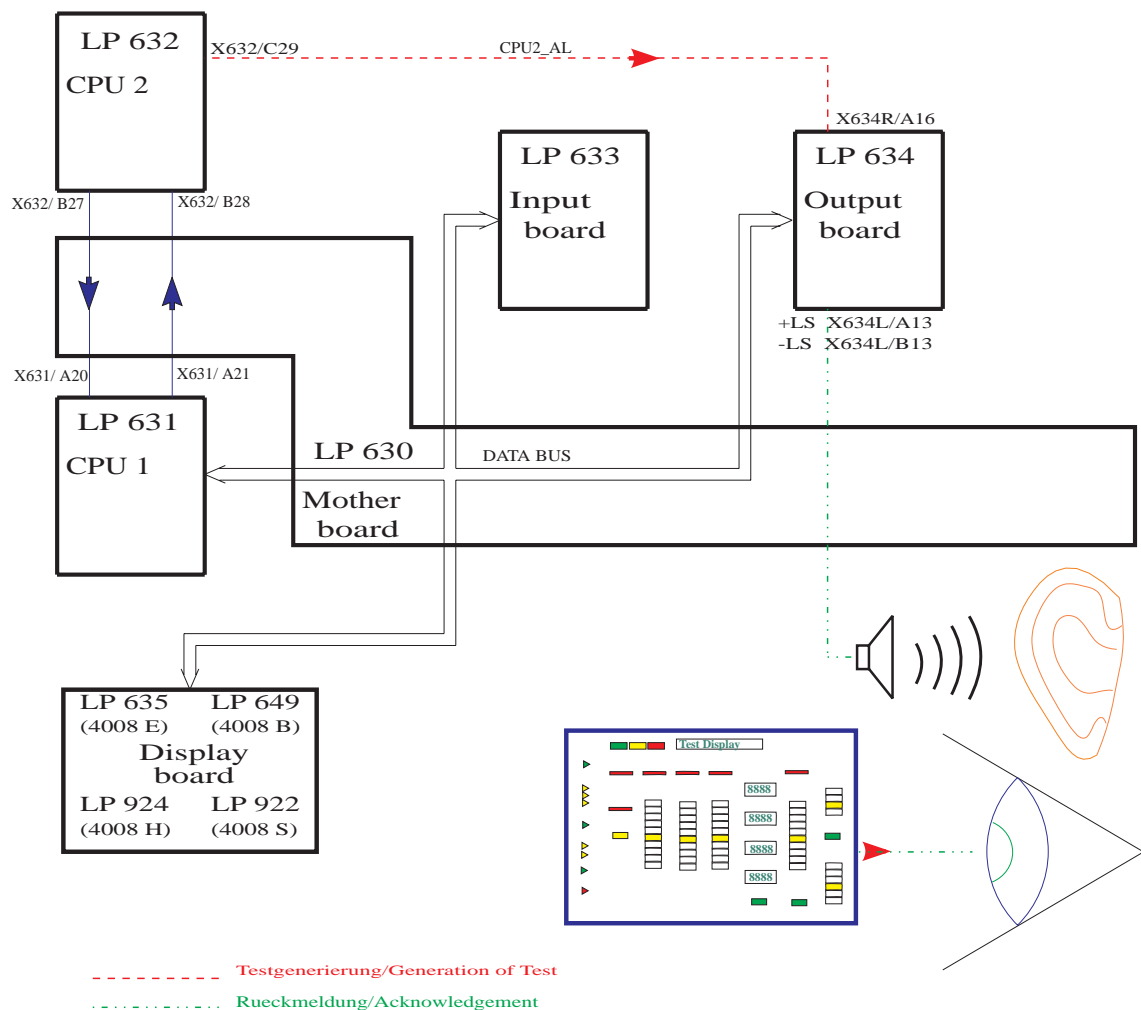

Error description:

<i>Error message</i>	<i>Description</i>
F01 Display	CPU1 failed to start the display test within 5 sec. – The “test started” information transmitted via the serial interface is missing.
F02 Display	CPU1 failed to complete the display test within 120 sec. – The “test completed” information transmitted via the serial interface is missing.
F95 Display	System error.

- Arterial pressure system test

Test description:

Test of the arterial pressure unit by electronic detuning in positive or negative direction.

Illustration:

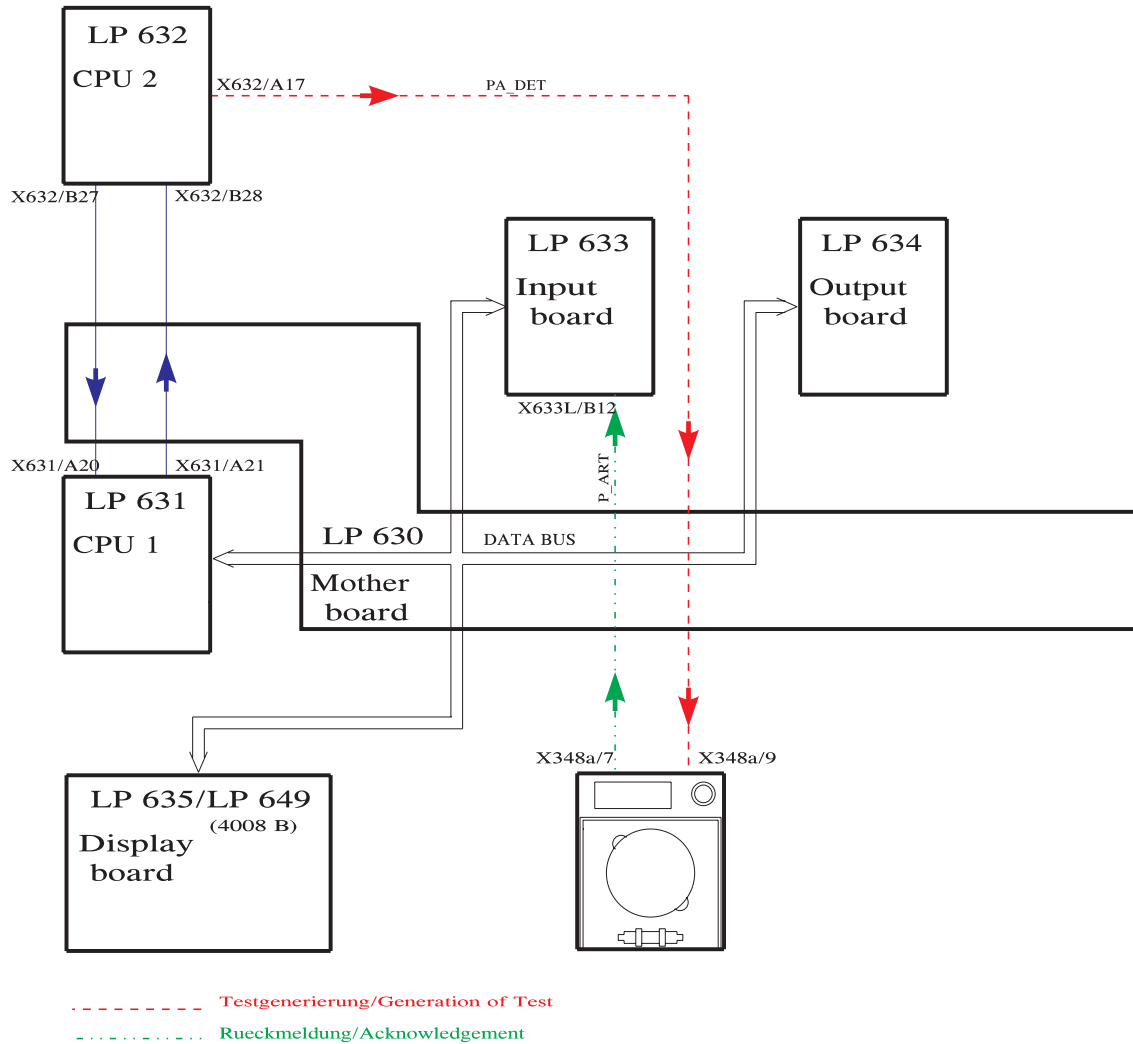

Error description:

<i>Error message</i>	<i>Description</i>
F01 Arterial	With detuning in negative direction, the change achieved on the arterial display is less than 100 mmHg (2 sec). <ul style="list-style-type: none">– Acknowledgement (P_ART, X348A/7) → X633L/B12, insufficient voltage change.– Test detuning defective (PA_DET, X632/A17) → X348A/9.
F02 Arterial	With detuning in positive direction, the change achieved on the arterial display is less than 100 mmHg (2 sec). <ul style="list-style-type: none">– Acknowledgement (P_ART, X348A/7) → X633L/B12, insufficient voltage change.– Test detuning defective (PA_DET, X632/A17) → X348A/9.
F95 Arterial	System error.

- **Battery test**

Test description:

Check of the battery voltage under load.

Illustration:

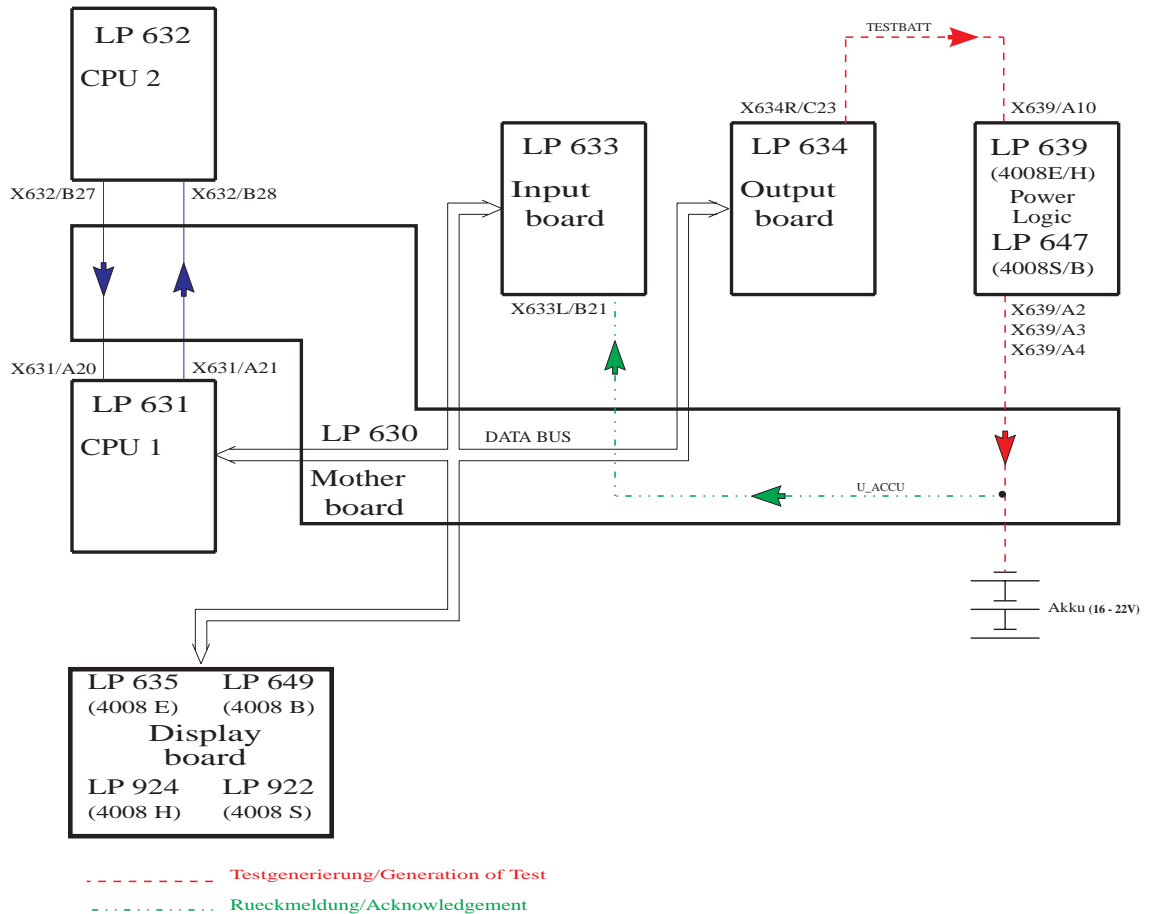

Error description:

<i>Error message</i>	<i>Description</i>
F01 Accumulator	CPU1 failed to complete the battery test within 5 sec. – The “test completed” information transmitted via the serial interface is missing.
F02 Accumulator	The battery charge is insufficient for 15 min emergency operation (maybe no battery connected). – The battery voltage (U_ACCU, ...) → X633L/B21 dropped below 17.6 V. – Acknowledgement (U_ACCU, ...) → X633L/B21 of the battery voltage defective.
F03 Accumulator	The test circuit on P.C.B. LP 639 defective. – The test level is incorrect (TESTBATT, X634R/C23) → X639/A10, the 12-V pulse is missing (100 ms). – Power supply unit LP 639 SI5 or in 4008B/S systems fuse in the base defective. – R39 on P.C.B. LP 639 (4008E/H) or P.C.B. LP 647 (4008B/S) defective, possibly caused by flickering power supply unit.
F95 Accumulator	System error.

- **Blood leak test**

Test description:

Test of the blood leak detector by lowering the capacity of the transmitting diode.

Illustration:

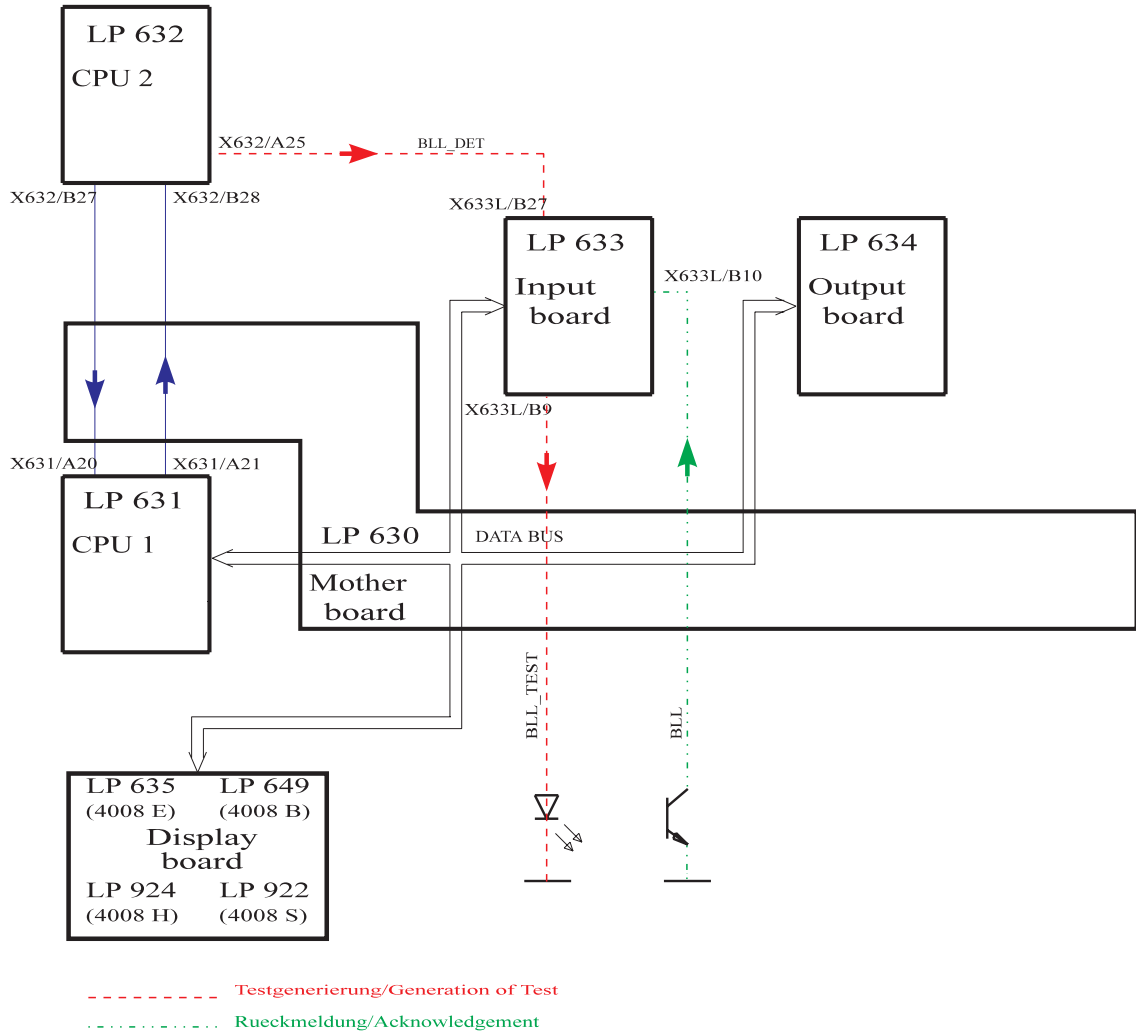

Error description:

Error message

Description

F01 Bloodleak

Blood leak channel and dimness not in alarm-free condition during the T1 test.

- Dimness channel contaminated (calcium precipitate, etc.)
- Acknowledgement (BLL, X637A/18) → X633L/B10 voltage value within the alarm tolerances (< 3V).
- Acknowledgement (BLL_DIM, X637A/21) → X633L/B11 voltage value within the alarm tolerances (<1.5V/ >8V).
- DAC_BLL or DAC_DIM not within the tolerances (check calibration)

F02 Bloodleak

The blood leak alarm/dimness alarm is not recognized during test detuning.

- Acknowledgement (BLL, X637A/18) → X633L/B10 voltage value not within the alarm tolerances.
- Acknowledgement (BLL_DIM, X637A/21) → X633L/B11 voltage value not within the alarm tolerances (<1.5V)
- Test detuning (BLL_DET, X632/A25) → X633L/B27 not 5V
- Calibration of DAC_BLL or DAC_DIM is too high
- Detuning (DAC_DIM, X634R/A11) → X633L/C3 impossible
- Dimness calibration is set to potentiometer calibration (BR6 from pos. 1/2 to 2/3).

F03 Bloodleak

After test detuning, the blood leak channel and dimness fail to enter the alarm-free state.

- Dimness channel contaminated (calcium precipitate, etc.)
- Acknowledgement (BLL, X637A/18) → X633L/B10 voltage value within the alarm tolerances
- Test detuning (BLL_DET, X632/A25) → X633L/B27 not 0V.
- Acknowledgement (BLL_DIM, X637A/21) → X633L/B11 voltage value within the alarm tolerances (<1.5V / >8V).
- DAC_BLL or DAC_DIM not within the tolerances (check calibration)

F95 Bloodleak

System error.

- Temperature test

Test description:

Test of the upper alarm limit by electronically detuning the temperature display in positive direction.

Illustration:

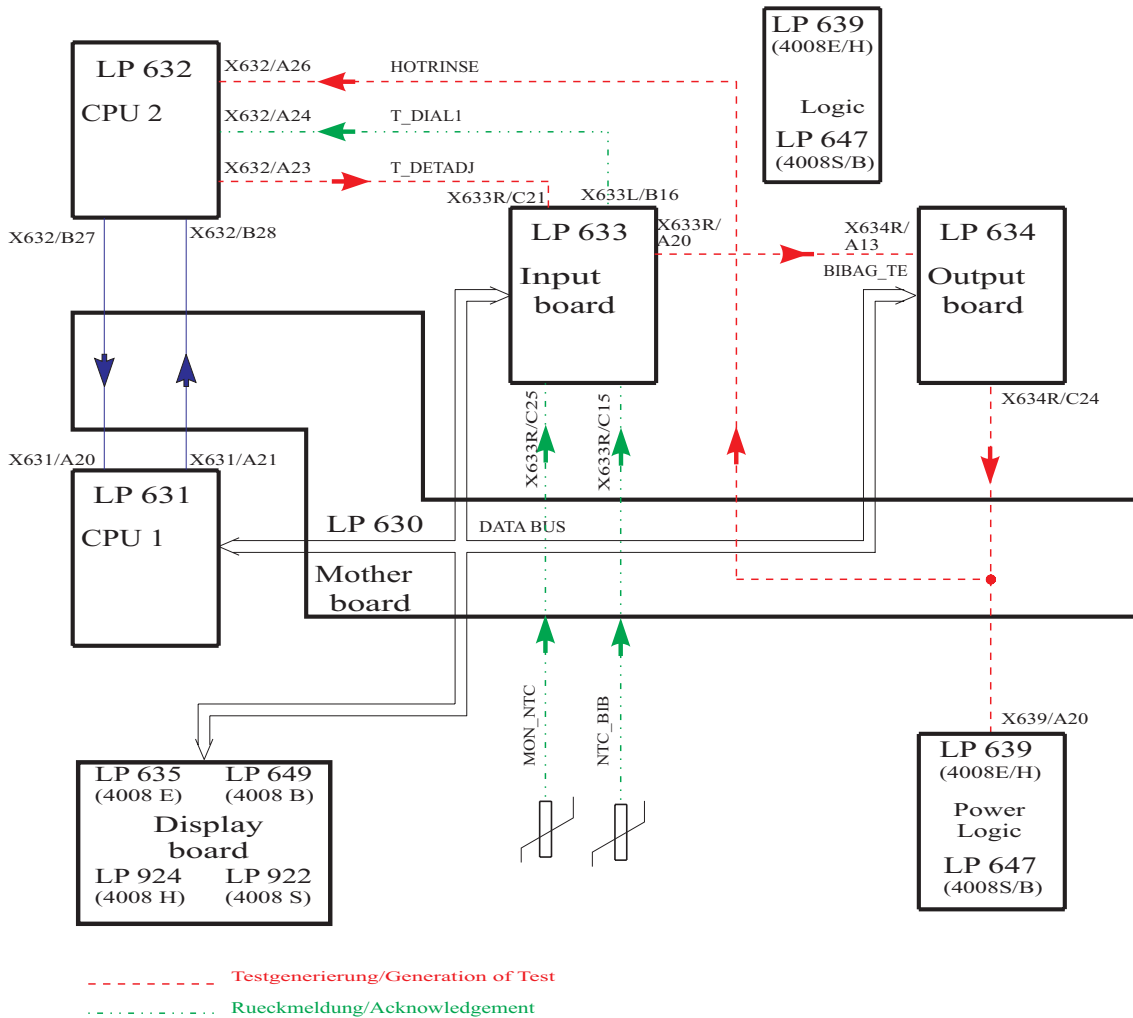

Error description:*Error message**Description*

F01 Temperature	The temperature measuring range is not set to hemodialysis. <ul style="list-style-type: none">– Control line (HOTRINSE, X634R/C24) → X639/A20, 0 V are missing.– Acknowledgement (HOTRINSE, X634R/C24) → X632/A26, 0 V are missing.
F02 Temperature	The actual temperature is less than 35.0 °C (test running time > 15 minutes). <ul style="list-style-type: none">– Calibrate the temperature.– The heater rod failed.– Acknowledgement (T_DIAL1, X633L/B16) → X632/A24, voltage got stuck.
F03 Temperature	The actual temperature is higher than 39.0 °C (test running time > 15 minutes). <ul style="list-style-type: none">– Calibrate the temperature.– The regulating sensor (NTC-2) is defective.– Acknowledgement (T_DIAL1, X633L/B16) → X632/A24, voltage got stuck.
F04 Temperature	The temperature failed to stabilize within 15 minutes. <ul style="list-style-type: none">– Acknowledgement (T_DIAL1, X633L/B16) → X632/A24 is steadily changing (change > 0.3 °C/15 sec).
F05 Temperature	Detuning in positive direction not higher than 3 °C (10 sec). <ul style="list-style-type: none">– Acknowledgement (T_DIAL1, X633L/B16) → X632/A24, change in voltage insufficient.– Detuning (T_DETADJ, X632/A23) → X633R/C21 insufficient.
F06 Temperature	The monitor sensor indicates a constant value. <ul style="list-style-type: none">– NTC-3 defective.
F07 Temperature	The test release is missing (max. test running time is 10 minutes). <ul style="list-style-type: none">– Run-time problem (software).
F08 Temperature	CPU1 failed to transmit a Bibag status message within 3 sec. <ul style="list-style-type: none">– Run-time problem (software).
F09 Temperature	Bibag NTC_BIB detuning not higher than 1 °C. <ul style="list-style-type: none">– Acknowledgement (NTC_BIB, X633R/C15) → ADW on P.C.B. LP 633, change in voltage insufficient.– Detuning (BIBAG_TE, X634R/A13) → X633R/A20 insufficient.
F10 Temperature	Bibag temperature display outside of measuring range (15 to 45 °C). <ul style="list-style-type: none">– Acknowledgement (NTC_BIB, X633R/C15) → ADW on P.C.B. LP 633.
F95 Temperature	System error.

- **Negative pressure holding test**

Test description:

Within a specific time period, the actual value of the dialysate pressure transducer should change within certain limits only.

Illustration:

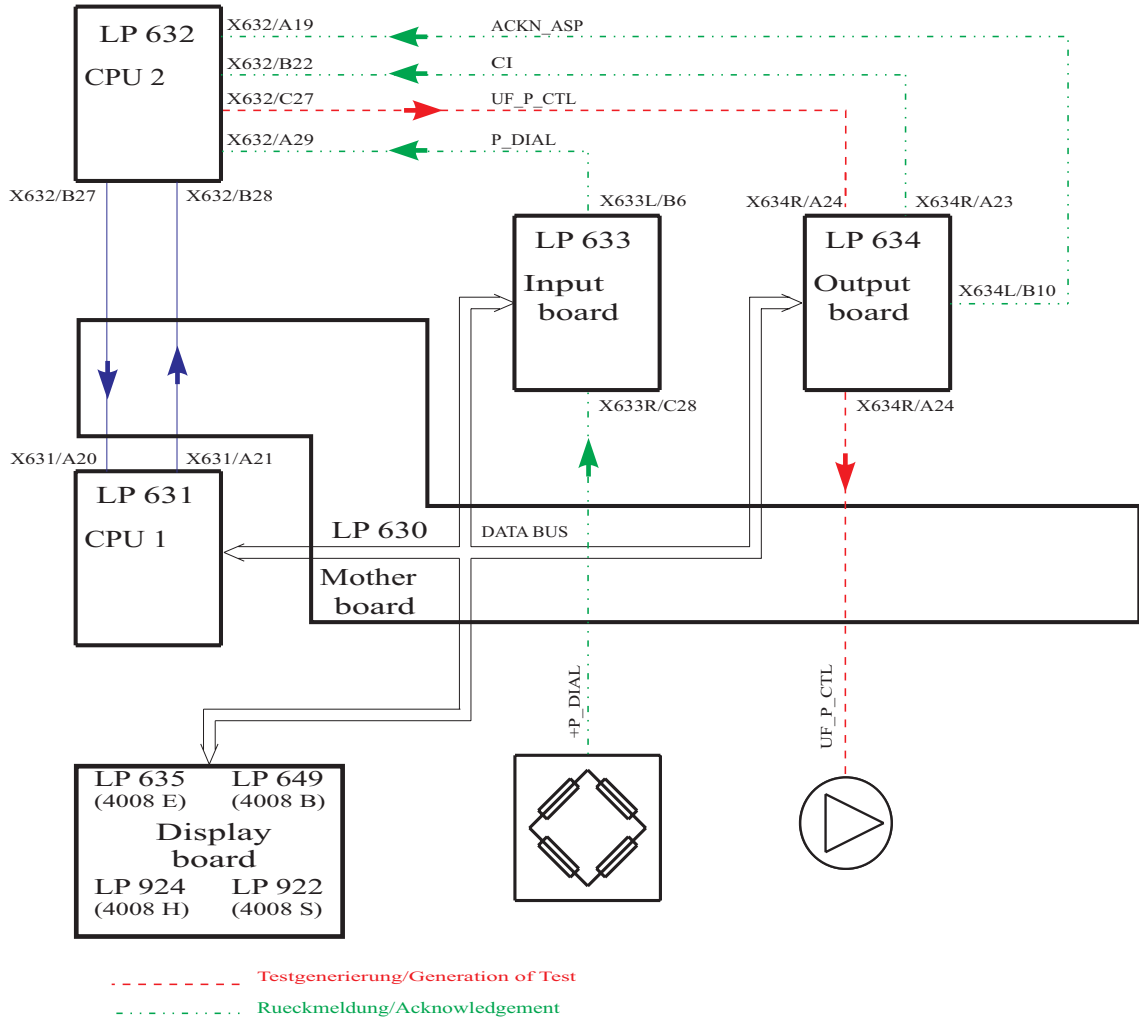

Error description:

<i>Error message</i>	<i>Description</i>
F01 neg. Pressure	During the start phase a negative pressure of more than 450 mmHg has developed (max. test running time 120 sec), <ul style="list-style-type: none">– the hydraulic system is contaminated,– the air separation pump started running.
F02 neg. Pressure	Setting the dialysate pressure to the test pressure (–300 mmHg to –450 mmHg) was not possible (max. test running time 120 sec). Upon repetition of measurement, the range was extended from –260 mmHg to 490 mmHg. <ul style="list-style-type: none">– Leakage in the hydraulic system.– The UF pump is defective.– If the HDF filter test was skipped: Clamp the HDF filter.
F03 neg. Pressure	The working point (116 digits) of the differential amplifier cannot be set correctly (max. test running time 120 sec). <ul style="list-style-type: none">– Pressure variations are too large.– The D-A converter (IC11) on P.C.B. LP 632 is defective.– The operational amplifier (IC1/IC3) on P.C.B. LP 632 is defective.– The acknowledgement (P_DIAL, X633L/B6) → X632/A29 is defective.– The CI signal is missing (LP 632 → X632/B22).
F04 neg. Pressure	Completion of pressure measurement was not possible (max. test running time 120 sec). <ul style="list-style-type: none">– The D-A converter (IC11) on P.C.B. LP 632 is defective.– The operational amplifier (IC1/IC3) on P.C.B. LP 632 is defective.– The acknowledgement (P_DIAL, X633L/B6) → X632/A29 is defective.
F05 neg. Pressure	The air separation pump started running during the measurement phase. <ul style="list-style-type: none">– Acknowledgement (ACKN_ASP, X634L/B10) → X632/A19, 0 V are missing.– ASP has been interrupted electrically.
F06 neg. Pressure	The negative pressure holding test failed to be passed. The dialysate pressure drop exceeds ±40 mmHg (related to ten balancing chamber switching). <ul style="list-style-type: none">– Leakage in the hydraulic system.
F07 neg. Pressure	Current increasing pulses were not recognized (min. 2x). <ul style="list-style-type: none">– 5-V balancing chamber pulses are missing (CI. X634R/A23) → X632/B22.
F95 neg. Pressure	System error.

In systems with HDF option, the negative pressure holding test is performed internally only; i.e. V24, V24B are closed and V26 is open.

- Positive pressure holding test

Test description:

Valves V24, V24B and V26 are checked for proper function (mechanical).

Test of the TMP unit by detuning it electronically in positive direction.

With the dialysate flow turned off, positive pressure is applied to the balancing system. The actual value of the dialysate pressure transducer is now monitored for a defined period of time.

Test of the pump segment of P97.

Illustration:

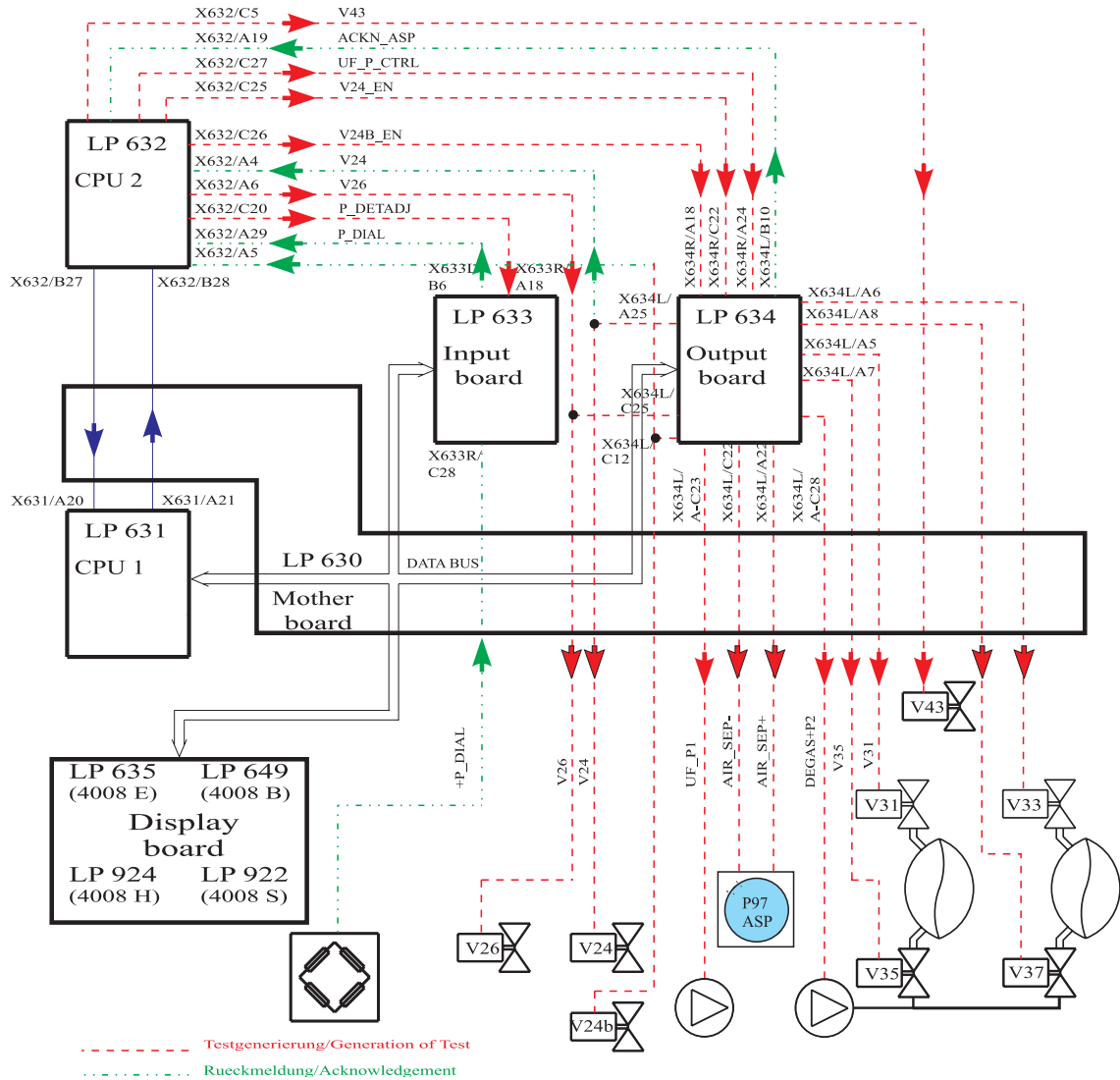

Error description:

<i>Error message</i>	<i>Description</i>
F01 pos. Pressure	The mandatory filling program of CPU1 has not been completed (10 sec). <ul style="list-style-type: none">– The solenoid valve V43 is not closed.
F24 pos. Pressure	V24 valve error. <ul style="list-style-type: none">– Acknowledgement (V24, X637/C1) → X632/A4, 24 V are missing.
F25 pos. Pressure	No pressure increase above 150 mmHg (change in pressure) after valve switching. <ul style="list-style-type: none">– Control signals of V24 and V24B mistaken for each other.– Leakage in the external system (shunt interlock, dialysate lines, etc.).– If the HDF filter test was skipped: Clamp the HDF filter.
F26 pos. Pressure	No pressure compensation after opening of V43 (–125 mmHg to 55 mmHg). <ul style="list-style-type: none">– V24 got stuck (mechanically open).– V43 not open.– V26 leaking.
F27 pos. Pressure	No pressure compensation after opening of V43 (–125 mmHg to 55 mmHg). <ul style="list-style-type: none">– V24 got stuck (mechanically open).– V43 not open.– V189 (retentate valve) leaking.
F02 pos. Pressure	The loading pressure cannot be measured via the solenoid valve V26 in the hydraulic system (P-Dial. < 600 mmHg, 15 sec). <ul style="list-style-type: none">– Solenoid valve V26 mechanically not open.– Solenoid valve V43 mechanically not closed. <p>The balancing chamber is switched to passage during this test sequence. V24, V24B and V43 are closed; V26 is open.</p>
F03 pos. Pressure	The hydraulic system cannot be deaerated via the solenoid valve V43; the zero point of –125 to 55 mmHg has not been reached (15 sec). <ul style="list-style-type: none">– Solenoid valve V26 mechanically not closed.– Solenoid valve V43 mechanically not open.– Zero point outside the –125 to 55 mmHg range. <p>The balancing chamber is switched to passage during this test sequence. V24, V24B and V26 are closed; V43 is open.</p>
F04 pos. Pressure	The first working point (220 digits) of the differential amplifier cannot be set. <ul style="list-style-type: none">– Pressure variations are too large.– The D-A converter (IC11) on P.C.B. LP 632 is defective.– The operational amplifier (IC1/IC3) on P.C.B. LP 632 is defective.– The acknowledgement (P_DIAL, X633L/B6) → X632/A29 is defective.

- F05 pos. Pressure** Test detuning results in a change in the measuring range of more than 95 mmHg (60 sec).
- The operational amplifier (IC2) on P.C.B. LP 632 is defective.
 - Acknowledgement (P_DIAL, X633L/B6) → X632/A29, change in voltage too large.
 - Detuning defective (P_DETADJ, X632/C20) → X633R/C22.
 - The balancing chamber valve V36 or V38 (waste water valve) is leaky.
- F06 pos. Pressure** Test detuning results in a change in the measuring range of less than 85 mmHg (60 sec).
- The D-A converter (IC11) on P.C.B. LP 632 is defective.
 - Acknowledgement (P_DIAL, X633L/B6) → X632/A29, change in voltage insufficient.
 - Detuning defective (P_DETADJ, X632/C20) → X633R/C22.
 - V26 is leaky.
- F07 pos. Pressure** After detuning in the test there is a difference (P.diff > ±9 mmHg) between the display and the differential amplifier.
- The voltage divider R23/R9 or the operational amplifier IC2 is defective.
 - The operational amplifier IC1/IC3 is defective.
 - The balancing chamber valve V36 or V38 (waste water valve) is leaky.
- F08 pos. Pressure** Test detuning results in a change in the measuring range of more than 400 mmHg (20 sec).
- The operational amplifier (IC2) on P.C.B. LP 632 is defective.
 - Acknowledgement (P_DIAL, X633L/B6) → X632/A29, change in voltage too large.
 - Detuning defective (P_DETADJ, X632/C20) → X633R/C22.
- F09 pos. Pressure** Test detuning results in a change in the measuring range of less than 350 mmHg (20 sec).
- The D-A converter (IC11) on P.C.B. LP 632 is defective.
 - Acknowledgement (P_DIAL, X633L/B6) → X632/A29, change in voltage insufficient.
 - Detuning defective (DIAL_DET_ADJ, X632/C20) → X633R/C22.
- F10 pos. Pressure** The second working point (116 digits) of the difference amplifier cannot be set correctly.
- The D-A converter (IC11) on P.C.B. LP 632 is defective.
 - The operational amplifier (IC1/IC3) on P.C.B. LP 632 is defective.
- F11 pos. Pressure** Change in the dialysate pressure after closing of the solenoid valve V43 (zero point change from –20 mmHg to +80 mmHg within 15 sec).
- The solenoid valve V24B is not closed.
 - The balancing chamber valve V36 or V38 (waste water valve) is leaky.
- The balancing chamber is switched to passage during this test sequence. V43, V24B and V26 are closed; V24 is open.

F12 pos. Pressure	<p>The loading pressure cannot be measured via the solenoid valves V24 and V24B in the hydraulic system (P-Dial. < 600 mmHg, 15 sec).</p> <ul style="list-style-type: none"> – Solenoid valve V24 or V24B mechanically not open. <p>The balancing chamber is switched to passage during this test sequence. V43 and V26 are closed; V24 and V24B are open.</p>
F13 pos. Pressure	<p>The hydraulic system cannot be deaerated via the solenoid valve V43 (P-Dial. not equal to –125 to 55 mmHg, 20 sec).</p> <ul style="list-style-type: none"> – The solenoid valve V24 is not closed. – V43 neither opens electrically nor mechanically. <p>The balancing chamber is switched to passage during this test sequence. V24 and V26 are closed; V24B and V43 are open.</p>
F14 pos. Pressure	<p>Zero point change after closing of solenoid valve V43 (20 sec). Standard: P-Dial. not equal to –125 to 55 mmHg. HDF option: P-Dial. not equal to –125 to 60 mmHg.</p> <ul style="list-style-type: none"> – The solenoid valve V24 is not closed. <p>The balancing chamber is switched to passage during this test sequence. V24, V26 and V43 are closed; V24B is open.</p>
F15 pos. Pressure	<p>The loading pressure is below 780 mmHg \pm30 mmHg (10 sec).</p> <ul style="list-style-type: none"> – The loading pressure is too low.
F16 pos. Pressure	<p>During the start phase, the pressure dropped below 620 mmHg (measuring tolerance: \pm30 mmHg, max. test running time 120 sec).</p> <ul style="list-style-type: none"> – Major leakage in the hydraulic system. – The UF pump spring is defective. – The loading pressure is too low. – The air separation pump fails to occlude. – Relief valve (78) or V43 is leaky.
F17 pos. Pressure	<p>During the start phase, it was not possible to reduce the dialysate pressure to a value below 760 mmHg (measuring tolerance: \pm30 mmHg, test running time 120 sec).</p> <ul style="list-style-type: none"> – The loading pressure is too high. – The UF pump is defective.
F18 pos. Pressure	<p>The working point (116 digits) of the differential amplifier cannot be set correctly (test running time 120 sec).</p> <ul style="list-style-type: none"> – The pressure variations in the system are too large.
F19 pos. Pressure	<p>Completion of the pressure measurement was not possible (max. test running time 120 sec).</p> <ul style="list-style-type: none"> – The D-A converter (IC11) on P.C.B. LP 632 is defective. – The acknowledgement (P_DIAL, X633L/B6) \rightarrow X632/A29 is defective.

F20 pos. Pressure	<p>The positive pressure holding test failed to be passed. While the flow was off, a pressure drop of more than ± 80 mmHg/min was detected in the hydraulic system.</p> <ul style="list-style-type: none"> – Leakage in the hydraulic system. – The UF pump spring is defective. – ASP fails to occlude. – Relief valve leaking. – V84 leaking.
F21 pos. Pressure	<p>The dialysate pressure cannot be set to a value between 460 and 760 mmHg ± 30 mmHg (10 sec).</p> <ul style="list-style-type: none"> – The heat exchanger is defective. – Problem in the hydraulic system.
F22 pos. Pressure	<p>The air separation pump is not running during the test phase (2 sec).</p> <ul style="list-style-type: none"> – Control line (AIR_SEP+, X634L/A22) → ASP/..., 24 V are missing. – Control line (AIR_SEP-, X634L/C22) → ASP/..., 0 V are missing. – Acknowledgement (ACKN_ASP, X634L/B10) → X632/A19, 12 V are missing.
F23 pos. Pressure	<p>Pressure drop in the hydraulic system during the measurement phase (8 sec). Change more than +4 digits or more than –8 digits.</p> <ul style="list-style-type: none"> – Leakage in the pump segment of the air separation pump. – Leakage in the heat exchanger. – Acknowledgement (P_DIAL, X633L/B6) → X632/A29, change in voltage too large.
F24 – F27	See between F01 and F02
F28 pos. Pressure	<p>ASP functional test (running and delivery test)</p> <ul style="list-style-type: none"> – ASP line segment is occluded – ASP line segment has been incorrectly inserted (check direction of delivery) – ASP is not running (electrically or mechanically) – V87 electrically or mechanically closed
F95 pos. Pressure	System error.

- **UF function test**

Test description:

CPU1 activates the UF pump at a defined rate.
 CPU2 checks the UF pump.
 CPU2 blocks the control line of the UF pump and checks whether the UF pump stops.
 Check of the UF counter.

The following is additionally applicable with built-in 4008 HDF option:

CPU1 activates the UF pump 2 at a defined rate.
 CPU2 checks the hydraulic and the electric function of the UF pump 2.
 CPU2 blocks the control line of the UF pump 2 and checks whether it stops.
 Check of the UF2 counter.

Illustration:

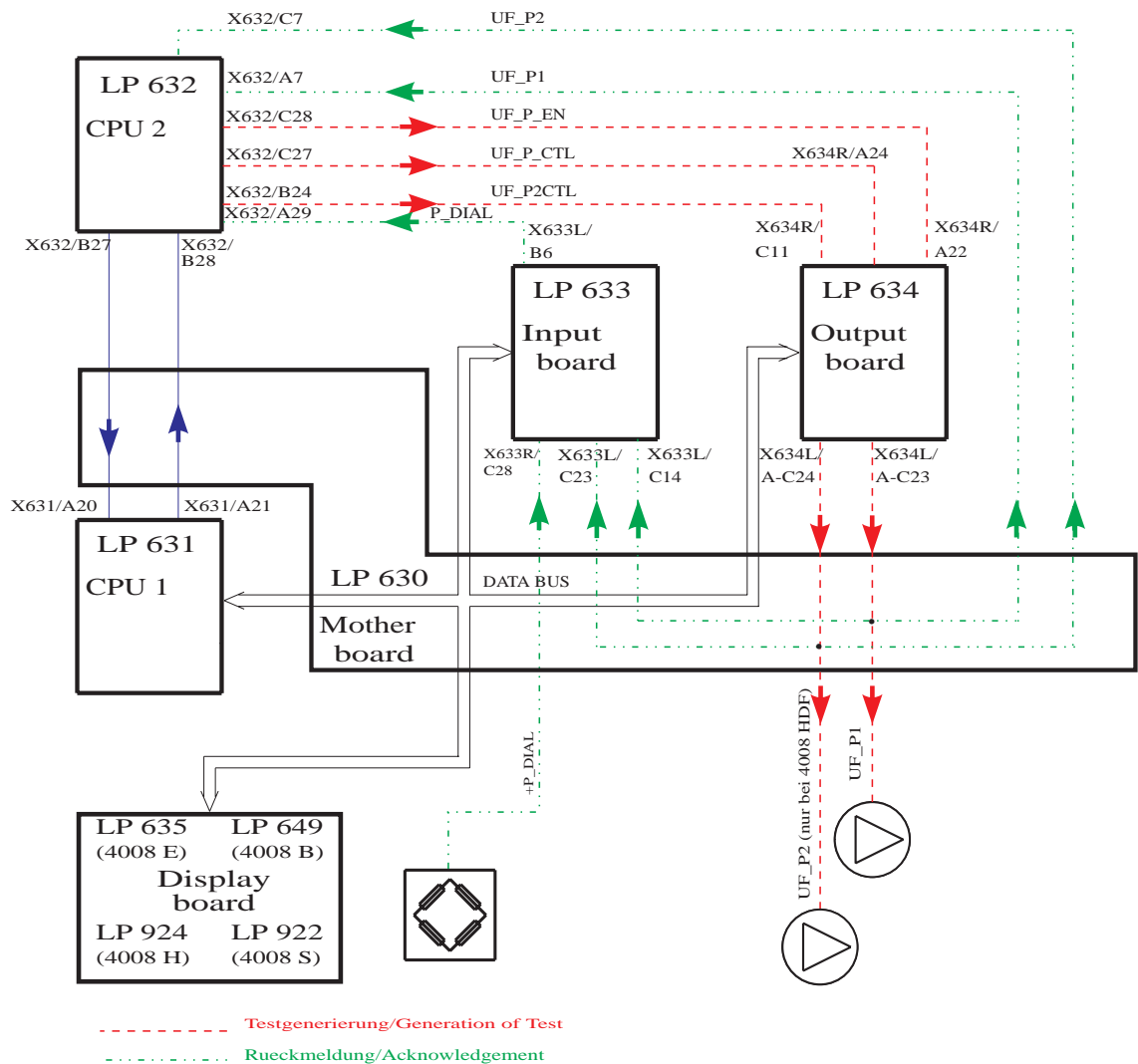

Error description:

<i>Error message</i>	<i>Description</i>
F01 UF-Function	The pause between the strokes of the UF pump 1 was shorter than 220 ms. Correct volume delivery is not ensured due to too short a return. <ul style="list-style-type: none">– CPU1 issued too high a pump rate.
F02 UF-Function	The pulse time for the UF pump 1 is shorter than 180 ms. Correct volume delivery is not ensured due to too short an emission time. <ul style="list-style-type: none">– The monoflop on P.C.B. LP 634 is defective (IC42/R82/C47).
F03 UF-Function	The pulse time for the UF pump 1 is longer than 500 ms. A maximum rate of 5000 ml/h is not possible. <ul style="list-style-type: none">– The monoflop on P.C.B. LP 634 is defective (IC42/R82/C47).
F04 UF-Function	No activity of the UF pump 1 during the test (5 sec). <ul style="list-style-type: none">– Acknowledgement (UF_P1, X637/B23) → X632/A7, no LOW pulses.– Control line (UF_P1, X634L/ABC23) → X637/B23, no LOW pulses.
F05 UF-Function	The UF pump 1 cannot be stopped by CPU2. <ul style="list-style-type: none">– Control line (UF_P_EN, X632/C28) → X634R/A22, 5 V are missing.– The reset input at IC42/pin 3 on P.C.B. LP 634 is defective.
F06 UF-Function	The UF pump acknowledgement of CPU1 is defective. <ul style="list-style-type: none">– Acknowledgement (UF_P1, X637/B23) → X622L/C14, no LOW pulses.
F07 UF-Function	The change in pressure after a stroke is less than 20 mmHg. <ul style="list-style-type: none">– The UF pump 1 is mechanically defective.– Control line (UF_P1_CTL, X632/C27) → X634R/A24, no LOW pulse.
F09 UF-Function	Dialysate pressure is outside the measuring range (15s). <ul style="list-style-type: none">– UF pressure transducer defective– D/A converter (IC11) on P.C.B. LP 632 defective– Operational amplifier (IC1/IC3) on P.C.B. LP 632 defective
F11 UF-Function	The pause between the strokes of the UF pump 2 was shorter than 220 ms. Correct volume delivery is not ensured due to too short a return. <ul style="list-style-type: none">– CPU1 issued too high a pump rate.
F12 UF-Function	The pulse time for the UF pump 2 is shorter than 180 ms. Correct volume delivery is not ensured due to too short an emission time. <ul style="list-style-type: none">– The monoflop on P.C.B. LP 634 is defective (IC42/R65/C45).

F13 UF-Function	The pulse time for the UF pump 2 is longer than 500 ms. A maximum rate of 5000 ml/h is not possible. <ul style="list-style-type: none"> – The monoflop on P.C.B. LP 634 is defective (IC42/R65/C45).
F14 UF-Function	No activity of the UF pump 2 during the test (4 sec). <ul style="list-style-type: none"> – Acknowledgement (UF_P2, X637/B26) → X632/C7, no LOW pulses. – Control line (UF_P2, X634L/ABC24) → X637/B26, no LOW pulses.
F15 UF-Function	The UF pump 2 cannot be stopped by CPU2. <ul style="list-style-type: none"> – Control line (UF_P_EN, X632/C28) → X634R/A22, 5 V are missing. – The reset input at IC42/pin 13 on P.C.B. LP 634 is defective.
F16 UF-Function	The UF pump acknowledgement of CPU1 is defective. <ul style="list-style-type: none"> – Acknowledgement (UF_P2, X637/B26) → X633L/C23, no LOW pulses.
F09 UF-Function	Dialysate pressure is outside the measuring range (15s). <ul style="list-style-type: none"> – UF pressure transducer defective – D/A converter (IC11) on P.C.B. LP 632 defective – Operational amplifier (IC1/IC3) on P.C.B. LP 632 defective
F17 UF-Function	The change in pressure after a stroke of the UF pump 2 is less than 20 mmHg. <ul style="list-style-type: none"> – The UF pump 2 is mechanically defective. – Control line (UF_P2_CTL, X632/B24) → X634R/C11, no HIGH pulse.
F20 UF-Function	The difference in volume between UF pump 1 and UF pump 2 is higher than 25% (range of tolerance 15% to 35%). <ul style="list-style-type: none"> – The stroke volume of UF pump 1 or UF pump 2 has been misadjusted.
F95 UF-Function	System error.

- **Conductivity test**

Test description:

Test of the alarm limits by electronically detuning the conductivity by +5% or by -5%.

Illustration:

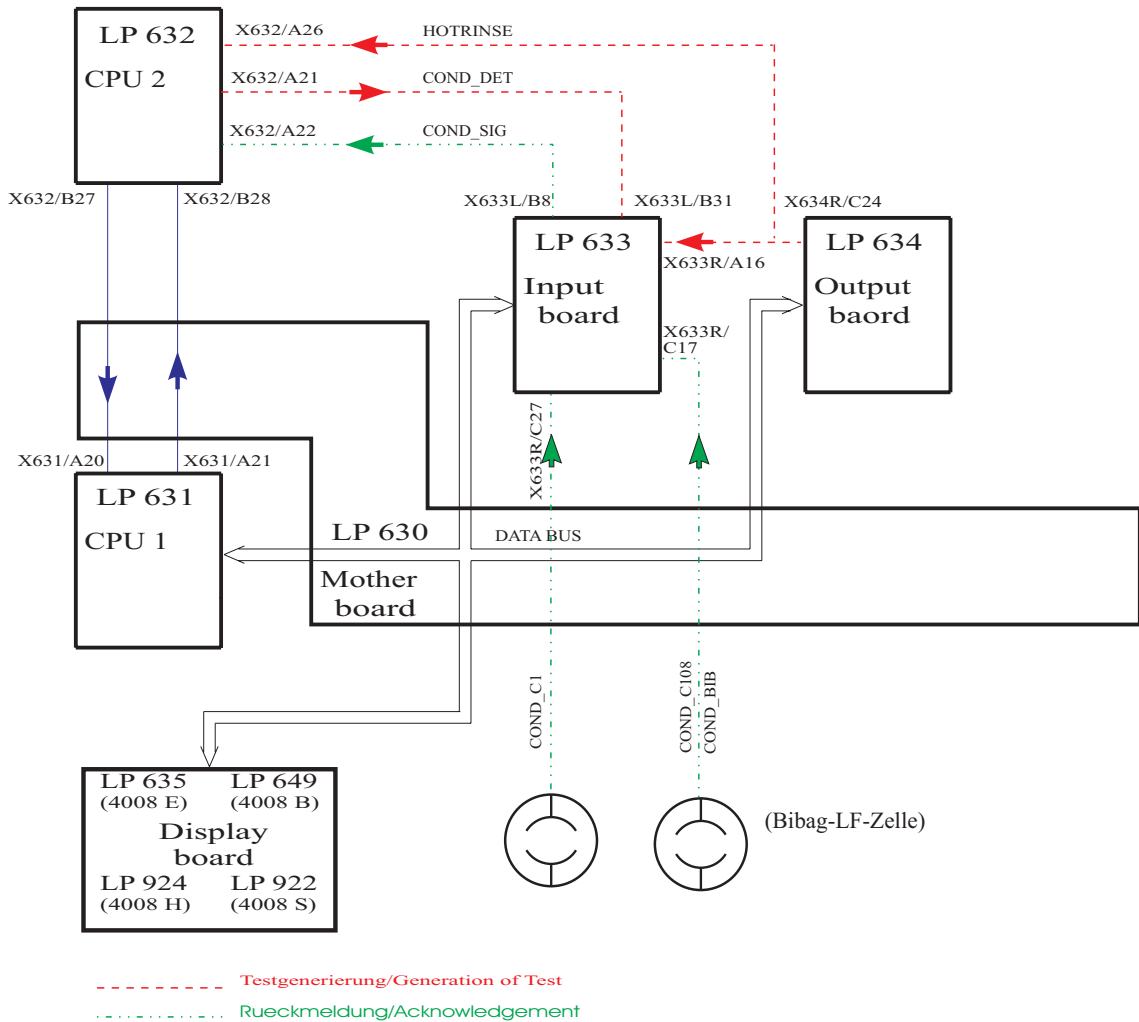

Error description:

<i>Error message</i>	<i>Description</i>
F01 Conductivity	The conductivity failed to be within the scale limits or to stabilize within 10 minutes (± 0.1 mS/10 sec). <ul style="list-style-type: none">– Concentrate is not connected.– Acknowledgement (COND_SIG, X633L/B8) → X632/A22, voltage outside the measuring range or unstable.
F02 Conductivity	Detuning in positive direction not more than 0.5 mS (10 sec). <ul style="list-style-type: none">– Acknowledgement (COND_SIG, X633L/B8) → X632/A22 insufficient.– Detuning (COND_DET, X632/A21) → X633L/B31 insufficient.
F03 Conductivity	Detuning in negative direction not more than 0.5 mS (10 sec). <ul style="list-style-type: none">– Acknowledgement (COND_SIG, X633L/B8) → X632/A22 insufficient.– Detuning (COND_DET, X632/A21) → X633L/B31 insufficient.
F04 Conductivity	The conductivity cell indicates a constant value. <ul style="list-style-type: none">– The CD cell is defective.
F05 Conductivity	CPU1 failed to transmit a Bibag status message within 3 sec. <ul style="list-style-type: none">– Run-time problem (software).
F08 Conductivity	CPU 1 fails to increase the working point (when the conductivity is < 40 mS/cm uncompensated) for the bibag conductivity by > 5 digits. <ul style="list-style-type: none">– Detuning (HOT_RINSE, X634R/C24 → X633R/A16) not 12V– P.C.B. LP 633 T2 or IC26 defective
F06 Conductivity	The Bibag CD detuning is not more than 1 mS/cm. <ul style="list-style-type: none">– Acknowledgement (COND_SIGNAL3, X633R/A12) → MP TP3 on P.C.B. LP 633, change in voltage insufficient.– Detuning (COND_DET, X632/A21) → X633L/B31 insufficient.
F07 Conductivity	The Bibag CD display is outside of the measuring range. <ul style="list-style-type: none">– Acknowledgement (COND_SIGNAL3, X633R/A12) → MP TP3 on P.C.B. LP 633.– Conductivity outside the expected detuning range caused by wrong concentrate on the bicarbonate port or temperature too low.
F95 Conductivity	System error.

- Diasafe/HDF filter test

Test description:

Test of the filters by testing the volume of the internal capillary and pressure holding test.

Illustration:

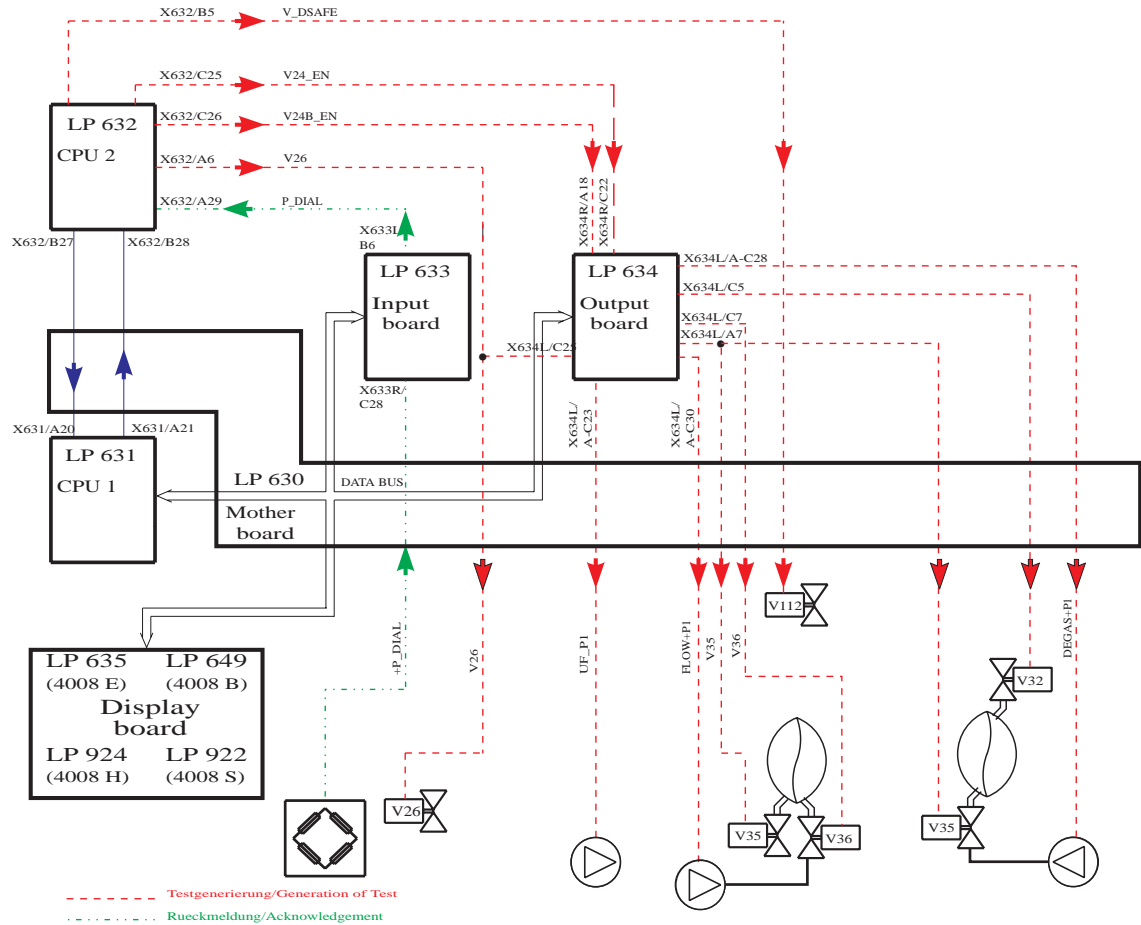

Error description:

<i>Error message</i>	<i>Description</i>
F02 Diasafe	The balancing chamber was not stopped by CPU1 (24 sec). <ul style="list-style-type: none">– The message via the serial interface from CPU1 to CPU2 is missing.– The current rise pulse is missing (CI, X634R/A23) → X633L/C31, no 5-V pulse.
F04 Diasafe	CPU1 failed to complete one balancing chamber switching within 20 sec (30 ml fluid not removed?). <ul style="list-style-type: none">– The message via the serial interface from CPU1 to CPU2 is missing.– The current rise pulse is missing (CI, 634R/A23) → 633L/C31, no 5-V pulse.
F06 Diasafe	During the pressure built-up phase, a negative pressure of less than –450 mmHg has developed (24 sec). <ul style="list-style-type: none">– Diasafe valve not open, control line (V_DSAFE, X632/B5) → X637/C16, 0 V are missing.
F07 Diasafe	After the maximum fluid volume of 145 ml + 30 ml has been removed, the expected negative pressure of –300 mmHg to –450 mm Hg failed to build up. <ul style="list-style-type: none">– Major leakage in the Diasafe filter membrane and/or filter housing.– Major leakage in the O-rings on filter holder/couplings.– V26 electrically or mechanically not closed.
F08 Diasafe	The negative test pressure of more than –300 mmHg has developed before the minimum fluid removal of 145 ml –30 ml has been achieved. <ul style="list-style-type: none">– The Diasafe filter is contaminated.– The Diasafe filter was not correctly deaerated upon start of the test.– V112 electrically or mechanically not open.
F09 Diasafe	The zero point for pressure measurement cannot be set. The maximum test time has been exceeded (max. test time 5 min). <ul style="list-style-type: none">– Leakage in the Diasafe filter membrane and/or filter housing.– Leakage in the O-rings on filter holder/couplings.– P.C.B. LP 632, IC3/pin 12 not in socket or IC defective (differential amplifier).
F10 Diasafe	The negative pressure to be achieved in the test failed to stabilize within the maximum test time of 5 minutes (change > ±16.7 mmHg/min). <ul style="list-style-type: none">– Leakage in the Diasafe filter membrane and/or filter housing.– Leakage in the O-rings on filter holder/couplings.– Leakage in the hydraulic system.– V 26 electrically or mechanically not closed.
F20 Diasafe	It was not possible to prime (deaerate) the dialysate filter within 2 minutes. <ul style="list-style-type: none">– Flow problems.– The priming program is permanently active (level sensor, osmosis water, or P.C.B. LP 633, IC36 defective).
F95 Diasafe	System error.

<i>Error message</i>	<i>Description</i>
F01 HDF-Filter	The Diasafe option has not been set although ON-LINE HDF has been selected. <ul style="list-style-type: none"> – CPU 2: DIP switch array 2, switch 1 not set to ON.
F02 HDF-Filter	CPU1 failed to stop the balancing chamber (24 sec). <ul style="list-style-type: none"> – The message via the serial interface from CPU1 to CPU2 is missing. – The current rise pulse is missing (CI, X634/A23) → X633L/C31, no 5-V pulse.
F04 HDF-Filter	CPU1 failed to complete one balancing chamber switching within 20 sec (30 ml fluid not removed?). <ul style="list-style-type: none"> – The message via the serial interface from CPU1 to CPU2 is missing. – Verify the current rise pulse.
F06 HDF-Filter	During the pressure-buildup phase, a negative pressure of less than –370 mmHg has developed (24 sec). <ul style="list-style-type: none"> – The HDF filter is clamped/clogged. – The Diasafe valve is not open, control line (V_DSAFE, X632/B5) → X637/C16, 0 V are missing.
F07 HDF-Filter	After the maximum fluid volume of 255 ml +60 ml has been removed the expected negative pressure of –220 mmHg up to 370 mmHg failed to build up. <ul style="list-style-type: none"> – Major leakage in the Diasafe/HDF filter membrane and/or filter housing. – Major leakage in the O-rings on filter holder/couplings. – V26 electrically or mechanically not closed.
F08 HDF-Filter	The negative test pressure of less than –220 mmHg has developed, before the minimum fluid removal of 255 ml –60 ml has been achieved. <ul style="list-style-type: none"> – The Diasafe/HDF filters are contaminated. – The Diasafe/HDF filters were not correctly deaerated upon start of the test. – V112 electrically or mechanically not open.
F09 HDF-Filter	The zero point for pressure measurement cannot be set. The max. test time has been exceeded (10 min). <ul style="list-style-type: none"> – Leakage in the Diasafe/HDF filter membrane and/or filter housing. – Leakage in the O-rings on filter holder/couplings.
F10 HDF-Filter	The negative pressure to be achieved in the test failed to stabilize within the maximum test time of 10 minutes (change > ±13.3 mmHg/min). <ul style="list-style-type: none"> – Leakage in the Diasafe/HDF filter membrane and/or filter housing. – Leakage in the O-rings on filter holder/couplings. – Leakage in the hydraulic system. – V26 electrically or mechanically not closed.

- F20 HDF-Filter** It was not possible to prime (deaerate) the Diasafe filter within 2 minutes.
- Flow problems.
 - The priming program is permanently active (level sensor, osmosis water, or P.C.B. LP 633, IC36 defective).
- F21 HDF-Filter** It was not possible to correctly rinse/prime the HDF filter within 5 minutes (before the test).
- Flow problems.
 - No conductivity.
 - Conductivity at the upper or lower end of the scale range.
 - The HDF pump is not running (e.g. open door).
 - The delivery rate of the HDF pump is less than 380 ml/min.
 - Line diameter not set to 8 mm.
 - NTC6 permanently fails to detect fluid.
 - Sieve on V43 clogged.
- F22 HDF-Filter** It was not possible to correctly rinse/prime the HDF filter within 5 minutes (after the test).
- Flow problems.
 - No conductivity.
 - Conductivity at the upper or lower end of the scale range.
 - Especially with biBag systems: check filter on V43
 - The HDF pump is not running (e.g. open door).
 - The delivery rate of the HDF pump is less than 380 ml/min.
 - Line diameter not set to 8 mm.
 - NTC6 permanently fails to detect fluid.
 - Sieve on V43 clogged.
- F95 HDF-Filter** System error.

- **Online plus / Diasafe plus filter / HPU test**

F01 ONLINE plus
F01 DIASAFE plus
F01 HPU

Present options and DIP switch settings do not match.
 CPU1 system status (MST), HPU status and DIP switch/Array2 changed during the test running time.

- **ONLINE plus:**
 CPU 2: Array 2, DipSw2 not set to OFF
 CPU 2: Array 2, DipSw3 not set to ON
- **DIASAFE plus:**
 CPU 2: Array 2, DipSw2 not set to OFF
 CPU 2: Array 2, DipSw3 not set to OFF
- MST transmitted by CPU1 not matching with the set DIP switch of array 2.
- DIP switch/Array2 changed while the test was in progress.
- HPU logged off.

F34 ONLINE plus
F34 DIASAFE plus

Pressure holding test not passed. Max. number of treatments exceeded?

- Diasafe and HDF filter membranes leaking/worn.

F02 ONLINE plus
F02 DIASAFE plus
F02 HPU

Dialysate outlet pressure (DA1) outside the permissible range (10s).

- DA1 test range: $-125\text{mmHg} \leq P_{\text{dial}} \leq 55\text{ mmHg}$
- Acknowledgement DA 1 (P_DIAL, X633L/B6) → X632/A29
 - Acknowledgement line DA 2 (see HPU diagram)

F03 ONLINE plus
F03 DIASAFE plus
F03 HPU

Cross comparison of both pressure transducers (DA1 / DA2) is outside the acceptable tolerance (10s).

- $P(\text{DA}2) == P(\text{DA}1) \pm 20\text{mmHg}$
- Acknowledgement DA 1 (P_DIAL, X633L/B6) → X632/A29
 - Acknowledgement DA 2 (see HPU diagram)

F41 ONLINE plus
F41 DIASAFE plus
F41 HPU

The test valve V183 is leaking. Pressure increase in the system of $\Delta P(\text{DA}2) > 30\text{ mmHg}$ within 4s.

- V183 open, contaminated, or mechanically defective
- HPU, output stage etc. defective

F42 ONLINE plus
F42 DIASAFE plus
F42 HPU

No pressure increase of $\Delta P(\text{DA}2) > 200\text{ mmHg}$ within 4s after opening the test valve V183 in the system.

- V183 fails to open or mechanically defective.
- Air pump defective, is not running
- HPU, V183 and/or air pump output stage etc. defective

**F43 ONLINE plus
F43 DIASAFE plus
F43 HPU**

The lower pressure test range of $\Delta P(\text{DA}2) > 300$ mmHg failed to be achieved within 1s after closing the test valve V183.

- HPU, output stage etc. defective
- ONLINE filter leaking

**F44 ONLINE plus
F44 DIASAFE plus
F44 HPU**

The upper pressure test range of $\Delta P(\text{DA}2)$ 750 mmHg was exceeded within 4s after closing of the test valve V183.

- HPU, output stage etc. defective

**F04 ONLINE plus
F04 DIASAFE plus**

The air pump is running although valve V43 is closed.

- HPU, output stage etc. defective

F05 ONLINE plus

The door on the Online Sys module is open during the rate test.

- Close module door.

F06 ONLINE plus

Port 1 is open during the first pressure build-up phase.

- Close port 1 (substitute port).

F07 ONLINE plus

Port 2 is open during the first pressure build-up phase.

- Close port 2 (rinse port).

F08 ONLINE plus

Failure to reach the test pressure PDIAL2 > 795 mmHg within 12s.

- Calibrate dialysate pressure.
- Replace DA 2 (re-calibration required)
- Air pump (185) or test valve (V183) defective
- Hydraulic system or valve ONL3 (191) leaking
- Air pump control (185) based on V43 status defective (HPU defective)

F09 ONLINE plus

The ONLINE system pump failed to comply with the first test rate of 100 ml/min ± 9 ml/min.

- ONLINE system pump control defective

F10 ONLINE plus

Monitoring unit (Hall sensor) of the pump rotor detects incorrect rotation of the rotor (desired rate 300 ml/min $\pm 25\%$).

- ONLINE system pump control defective (outside the tolerance of $\pm 25\%$)
- Hall sensor /electronics defective

F11 ONLINE plus

The ONLINE system pump failed to comply with the second test rate of 300 ml/min ± 9 ml/min.

- ONLINE system pump control defective

F12 ONLINE plus

After the ONLINE system pump was switched off in the test, the monitoring unit (Hall sensor) detects that the rotor failed to stop correctly.

- Pump stop (output stage) defective
- Hall sensor /electronics defective

F13 ONLINE plus	<p>After the ONLINE system pump was switched off in the test, the actual rate of the module is > 0 ml/min.</p> <ul style="list-style-type: none"> – Pump stop (output stage) defective – Synchro-transmitter electronics defective
F14 ONLINE plus	<p>After activation of the substitute pump the monitoring unit (Hall sensor) of the pump rotor detects incorrect rotation of the rotor (desired rate 300 ml/min).</p> <ul style="list-style-type: none"> – Pump control defective (outside the tolerance of $\pm 25\%$) – Hall sensor /electronics defective
F15 ONLINE plus	<p>After activation of the substitute pump the system pump failed to comply with the test rate of 300 ml/min ± 9ml/min.</p> <ul style="list-style-type: none"> – Pump control defective
F16 ONLINE plus	<p>Port 1 open during ONL valve test sequence.</p> <ul style="list-style-type: none"> – Close port 1 (substitute port).
F17 ONLINE plus	<p>Port 2 open during ONL valve test sequence.</p> <ul style="list-style-type: none"> – Close port 2 (rinse port).
F18 ONLINE plus	<p>Acknowledgement of ONL1 (V193) differs from the desired state of the valve.</p> <ul style="list-style-type: none"> – Valve control in the ONLINE Sys module defective – Valve acknowledgement in the ONLINE Sys module defective
F19 ONLINE plus	<p>Acknowledgement of ONL2 (V192) differs from the desired state of the valve.</p> <ul style="list-style-type: none"> – Valve control in the ONLINE Sys module defective – Valve acknowledgement in the ONLINE Sys module defective
F20 ONLINE plus	<p>Acknowledgement of ONL3 (V191) differs from the desired state of the valve.</p> <ul style="list-style-type: none"> – Valve control in the ONLINE Sys module defective – Valve acknowledgement in the ONLINE Sys module defective
F21 ONLINE plus	<p>Leakage test ONL3 (V191) failed to be passed. The permitted pressure drop of $\Delta P < -10$ mmHg has been exceeded or the test pressure is $P \leq 710$ mmHg.</p> <ul style="list-style-type: none"> – Valve ONL3 (V191) in the ONLINE Sys module leaking – Leaking system / tubing connections – Port 1 or 2 in the ONLINE Sys module leaking
F22 ONLINE plus	<p>Leakage test ONL2 (V192) failed to be passed. The permitted pressure drop of $\Delta P < -10$ mmHg has been exceeded or the test pressure is $P \leq 710$ mmHg.</p> <ul style="list-style-type: none"> – Valve ONL2 (V192) in the ONLINE Sys module leaking – Leaky system /tubing connections – Port 1 in the ONLINE Sys module leaking
F23 ONLINE plus	<p>Leakage test ONL1 (V193) failed to be passed. The permitted pressure drop of $\Delta P < -10$ mmHg has been exceeded or the test pressure is $P \leq 710$mmHg.</p> <ul style="list-style-type: none"> – Valve ONL1 (V193) in the ONLINE Sys module leaking – Leaky system /tubing connections

F24 ONLINE plus	<p>After the valves ONL1 to 3 opened, the pressure drop in the system was insufficient ($\Delta P < -100$ mmHg).</p> <ul style="list-style-type: none"> - Valve ONL1/ONL2/ONL3 electrically or mechanically not open - Kinked tubing - HDF filter strongly contaminated
F25 ONLINE plus	<p>No pressure change of $\Delta P > 40$ mmHg within 15s.</p> <ul style="list-style-type: none"> - HDF filter membrane leaking (major leakage) - No HDF filter installed
F26 ONLINE plus F26 DIASAFE plus	<p>Insufficient test pressure ($P < 750$mmHg) in the system.</p> <ul style="list-style-type: none"> - HDF filter membrane leaking (major leakage) - No HDF filter installed - Hydraulics system leaking
F27 ONLINE plus F27 DIASAFE plus	<p>After the valve V189 opened, the pressure drop in the system was insufficient ($\Delta P < -70$ mmHg).</p> <ul style="list-style-type: none"> - Valve V189 electrically or mechanically not open - Diasafe filter strongly contaminated - Filter before/after V43 strongly contaminated
F28 ONLINE plus F28 DIASAFE plus	<p>Pressure increase in the system fails to exceed $P > 760$ mmHg.</p> <ul style="list-style-type: none"> - Diasafe filter membrane leaking (major leakage) - No Diasafe filter installed
F29 ONLINE plus F29 DIASAFE plus	<p>Pressure holding test failed to be passed. Excess pressure drop within a measurement time of 30s ($\Delta P > -10$ mmHg).</p> <ul style="list-style-type: none"> - Diasafe and/or HDF filter membrane leaking
F30 ONLINE plus F30 DIASAFE plus	<p>During the pressure holding test valve(s) ONL1, 2 or 3 and/or V189 was (were) closed (according to electronic acknowledgement).</p> <ul style="list-style-type: none"> - Valve control failed
F31 ONLINE plus F31 DIASAFE plus F31 HPU	<p>Fill phase has been stopped.</p> <p>Valve(s) V26 open and/or V24, V24b closed (according to electronic acknowledgement), or failure to perform 25 or 15 balancing chamber switchings within 120s.</p> <ul style="list-style-type: none"> - Valve control failed - Balancing chamber switchings failed (e.g. only "Eigentakt")
F32 ONLINE plus	<p>Valve(s) ONL1, 2 or 3 closed and/or V24 open or port 1 or 2 open during the rinse phase (according to electronic acknowledgement).</p> <ul style="list-style-type: none"> - Valve control failed - Operator opened ports too early.

F33 ONLINE plus	Rinse phase has been aborted. Valve V189 open (according to electronic acknowledgement), or failure to perform 34 balancing chamber switchings within 240s.
	<ul style="list-style-type: none"> – Valve control failed – Failure to detect current rise pulse – Conductivity not within the scale range
	Possible cause: Concentrate and/or bicarbonate level sensor do not recognize CD, although present.
F34 ONLINE plus F34 DIASAFE plus	See error message between F01 and F02 ONLINE plus /DIASAFE plus
F41 ONLINE plus F41 DIASAFE plus	See error message between F01 and F02 ONLINE plus /DIASAFE plus
F42 ONLINE plus F42 DIASAFE plus	See error message between F03 and F04 ONLINE plus /DIASAFE plus
F43 ONLINE plus F43 DIASAFE plus	See error message between F03 and F04 ONLINE plus /DIASAFE plus
F44 ONLINE plus F44 DIASAFE plus	See error message between F03 and F04 ONLINE plus /DIASAFE plus
F95 ONLINE plus F95 DIASAFE plus F95 HPU	System error

1.1.4 Description of system errors during the cleaning programs

- **V84 monitoring**

<i>Error message</i>	<i>Description</i>
Rinse Failure F01	End of the rinse-free program in Dis I to V. Conductivity has been recognized via V84, although the valve is still closed. This error message can be acknowledged by pressing the Rinse key.
Rinse Failure F21	Disinfectant suction phase in Dis I – IV. Maximum permissible UF pump strokes (160) during the suction phase) exceeded. Error message cannot be acknowledged. Turn the system off and on again.
Rinse Failure F02	Disinfectant suction phase in Dis I to IV. Conductivity has not been recognized via V84, and the “Disinfectant empty ?” message has been acknowledged twice. This error message cannot be acknowledged. Switch the system off and on again. Program Dis V (only on systems with advanced hydraulics) No conductivity detected via concentrate level sensor, and “Disinfectant empty ?” message acknowledged twice. Error message cannot be acknowledged. Turn the system off and on again.
Rinse Failure F03	End of the suction phase in Dis I to IV. Conductivity has been recognized via V84, although the valve is already closed. This error message can be acknowledged by pressing the Disinfection key.
Rinse Failure F04	End of the suction phase in Dis I to IV. The float switch does not recognize any fluid after the disinfectant has been drawn in. Aeration of the disinfectant container! This error message cannot be acknowledged. Turn the system off and on again.

F01, F02 and F03 cause the V84 monitoring flag to be set. I.e. after one of these error messages has occurred, Bergström or ISO-UF dialysis is no longer possible, since it is not possible to switch the flow off. The V84 malfunction can be eliminated by correctly performing Dis I to IV. The problem can also be corrected using the calibration program (by a service technician only), menu item NOVRAM (Reset V84).

● **PSW (pressure switch) monitoring during free rinsing (only with systems with CDS)**

The following requirements must be fulfilled to run the PSW test:

- DIP switch 8 Dip array 2 on P.C.B. LP631 must be set to ON.
- Rinse free followed by disinfection or heat disinfection (Dis. I-V)
or
Mandatory rinse as individual program

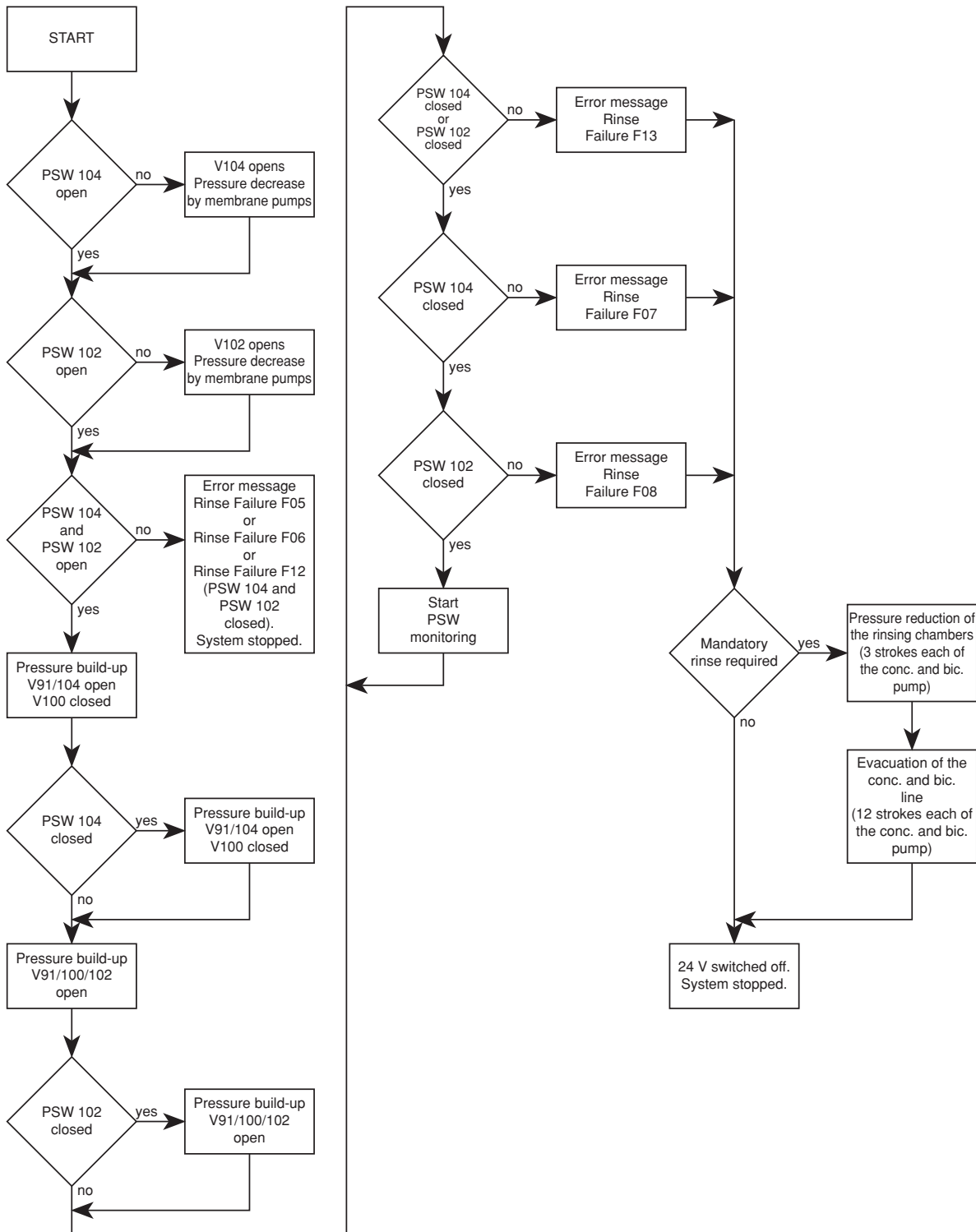

The pressure switches are designed as make contacts.

Specifications:

Delta pressure switch: Switching point 700 mbar \pm 20 mbar
Alcatel-SEL-pressure switch: Switching range 675 – 805 mbar
Envec pressure switch: Switching range 700 mbar \pm 20 mbar

Error message

Description

Rinse Failure F05

Rinse-free program with following Dis or HDIS or mandatory rinse as individual program in Dis I to V.

It was impossible to open the pressure switch for PSW_104 (S124) (bicarbonate).

- Pressure on distribution piping > 500 mbar (according to specification, the permissible pressure is max. 500 mbar) pressure peaks on distribution piping: Frequently occurs in distribution pipings with user points if e.g. several patients are disconnected simultaneously and disinfection is started.
- Switching point of pressure switch too low:
Desired value = 700 mbar \pm 20 mbar
- Check acknowledgement of pressure switch on P.C.B. LP 633:
Bicarbonate: X633L/ A19

Rinse Failure F06

Rinse-free program with following Dis or HDIS or mandatory rinse as individual program in Dis I to V.

It was impossible to open the pressure switch for PSW_102 (S123) (concentrate).

- Pressure on distribution piping > 500 mbar (according to specification, the permissible pressure is max. 500 mbar) pressure peaks on distribution piping: Frequently occurs in distribution pipings with user points if e.g. several patients are disconnected simultaneously and disinfection is started.
- Switching point of pressure switch too low:
Desired value = 700 mbar \pm 20 mbar
- Check acknowledgement of pressure switch on P.C.B. LP 633:
Concentrate: X633L/ A20

Rinse Failure F07

Rinse-free program, Dis, HDIS, or mandatory rinse in Dis I to V.

Pressure drop during the monitoring phase on PSW_104 (S124) (bicarbonate) or pressure build-up impossible.

- Check switching point of pressure switch
- Check loading pressure
(possibly splinter or contamination in orifice 151, remove tube and purge tube from both ends).
- Check negative pressure and test orifice (89).
(For this purpose, remove and purge the tubing from both ends)
- Check check valve (118) and filter (120).
- Check CDS valve (104).
- Verify tightness of CDS path.
- Check acknowledgement of pressure switch on P.C.B. LP 633:
Bicarbonate: X633L/ A19
- Cartridge filter upstream of degassing pump clogged or wrong filter (filter for disinfectant container) installed. Filters can be distinguished by different adapters.

Rinse Failure F08

Rinse-free program, Dis, HDIS, or mandatory rinse in Dis I to V.
Pressure drop during the monitoring phase on PSW_102 (S123) (concentrate) or pressure build-up impossible.

- Check switching point of pressure switch.
- Check loading pressure.
(possibly splinter or contamination in orifice 151, remove tube and purge tube from both ends)
- Check negative pressure and orifice (89).
(For this purpose, remove and purge the tubing from both ends)
- Check check valve (117) and filter (119).
- Check CDS valve (102).
- Verify tightness of CDS path.
- Check acknowledgement of pressure switch on P.C.B. LP 633:
Concentrate: X633L/ A20
- Cartridge filter upstream of degassing pump clogged or wrong filter (filter for disinfectant container) installed. Filters can be distinguished by different adapters.

Rinse Failure F09

Five minutes before the end of the mandatory rinse in Dis I to V.
Pressure switch PSW_104 (S124) (bicarbonate) or PSW_102 (S123) (concentrate) did not open after pressure reduction.
See Rinse Failure F12.

Rinse Failure F12

Rinse-free program with following Dis or HDIS or mandatory rinse as individual program in Dis I to V.

The pressure switches for PSW_104 (S124) (bicarbonate) and for PSW_102 (S123) (concentrate) could not be opened.

- Membrane pumps fail to run.
- V 102 or 104 fails to open.
- Pressure on distribution piping > 500 mbar (according to specification, the permissible pressure is max. 500 mbar) pressure peaks on distribution piping: Frequently occurs in distribution pipings with user points if e.g. several patients are disconnected simultaneously and disinfection is started.
- Switching point of pressure switch too low:
desired value = 700 mbar ± 20 mbar
- Check acknowledgement of pressure switch on P.C.B. LP 633:
Bicarbonate: X633L/ A19

Rinse Failure F13

Rinse-free program with following Dis or HDIS or mandatory rinse as individual program in Dis I to V.

Pressure drop during the monitoring phase on PSW_104 (S124) (bicarbonate) or PSW_102 (S123) (concentrate) or pressure build-up impossible.

- Check switching point of pressure switch.
- Check loading pressure.
(Possibly splinter or contamination in orifice 151; remove tube and blow through tube from both ends)
- Check negative pressure and orifice (89).
(For this purpose, remove and purge the tubing from both ends)
- Check check valve (117/118) and filter (119/120).
- Check CDS valve (102/104).
- Verify tightness of CDS path.
- Check acknowledgement of pressure switch on P.C.B. LP 633:
Bicarbonate: X633L/ A19
Concentrate: X633L/ A20
- Cartridge filter upstream of degassing pump clogged or wrong filter (filter for disinfectant container) installed. Filters can be distinguished by different adapters.

In case of F07, F08 and F13, the "DO NOT SWITCH OFF !!" message can, in addition, be alternately displayed.

However, this message is displayed only if a mandatory rinse program is requested, since the concentrate and bicarbonate lines still have to be emptied before the system is switched off.

● **Hydraulics test (check of V91, V99, V100) in systems with central delivery system**

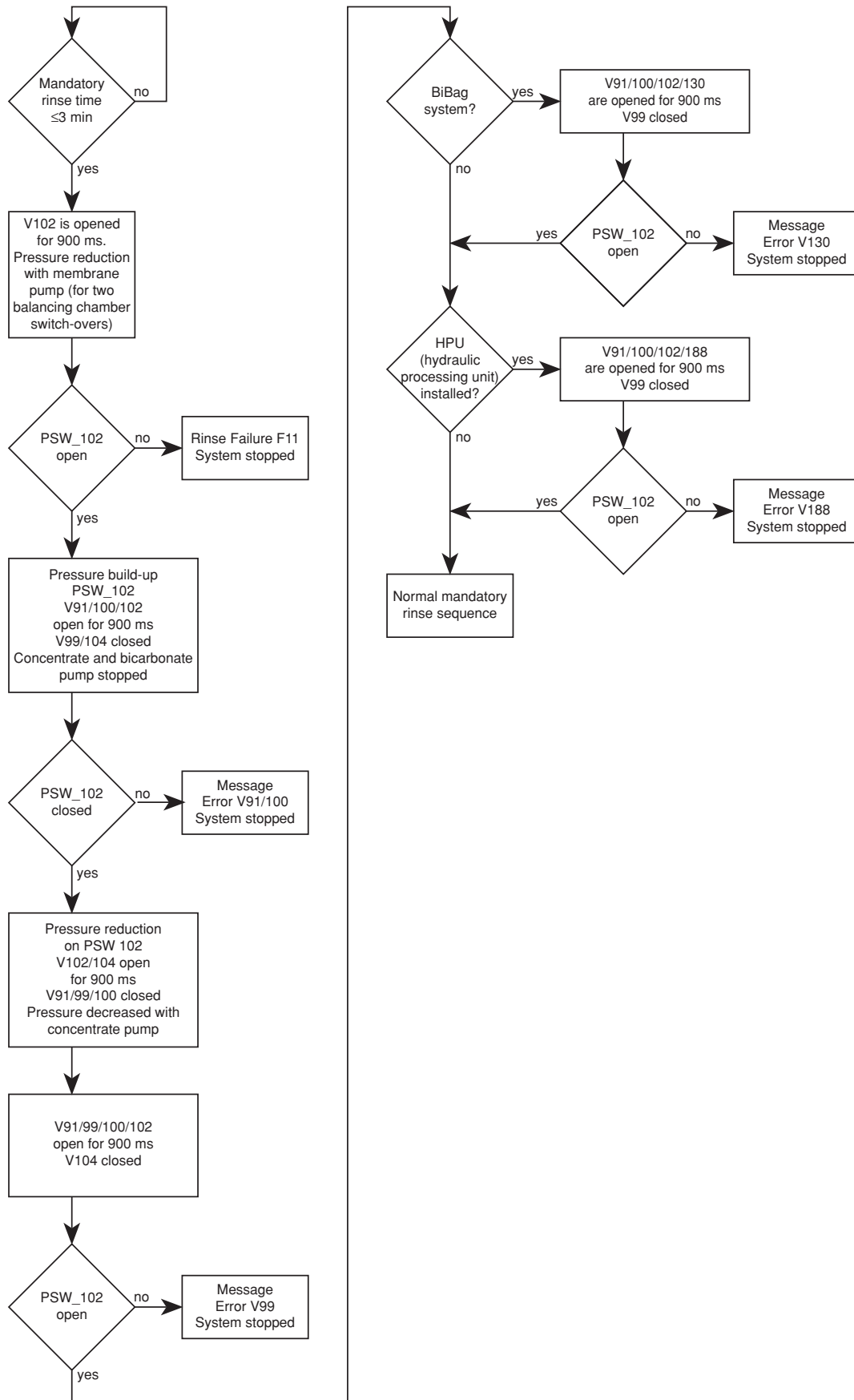

<i>Error message</i>	<i>Description</i>
Rinse Failure F11	<p>Three minutes before the end of the mandatory rinse in Dis I to V. The pressure switch PSW_102 (S123) (concentrate) did not open after pressure reduction.</p> <ul style="list-style-type: none"> – Pressure on distribution piping > 500 mbar (according to specification, the permissible pressure is max. 500 mbar). Pressure peaks on distribution piping: Frequently occurs in distribution pipings with user points if e.g. several patients are disconnected simultaneously and disinfection is started. – Switching point of pressure switch too low: desired value = 700 mbar ± 20 mbar – Membrane pumps fail to run – V102 fails to open electrically or mechanically – Check acknowledgement of pressure switch on P.C.B. LP 633: X633L/ A20
V91/V100 Failure	<p>Three minutes before the end of the mandatory rinse in Dis I to V. V91 or V100 cannot be opened.</p> <ul style="list-style-type: none"> – V91 or V 100 fail to open electrically: P.C.B. LP 634: V91 = X634L/A12; V100 = X634L/C13 – V 91 or V 100 mechanically not open: check sieve (148) upstream of V100, or valves clogged – V99 constantly open (electrically P.C.B. LP 634: X634L/B12 or mechanically) – V 102 not open – Pressure switch for PSW_102 (S 123) fails to switch
V99 Failure	<p>Three minutes before the end of the mandatory rinse in Dis I to V. V99 cannot be opened.</p> <ul style="list-style-type: none"> – V 99 fails to open electrically: P.C.B. LP 634: X634L/ B12. – V 99 fails to open mechanically: check sieve (149) before V99, or V99 clogged. – Pressure switch for PSW_102 (S 123) fails to open.
V130 Failure	<p>Three minutes before the end of the mandatory rinse in Dis I to V. V130 cannot be opened (applicable to systems with BIBAG only).</p> <ul style="list-style-type: none"> – V130 electrically defective: P.C.B. LP 634: X634L/ A4 – V130 mechanically defective or clogged – Pressure switch for PSW_102 (S 123) fails to open. – Check tubing for bicarbonate suction line and bibag block.
V188 Failure	<p>V188 fails to open.</p> <ul style="list-style-type: none"> – V188 electrically defective. – V188 mechanically defective or clogged – Pressure switch for PSW_102 (S123) fails to open.
F14	<p>Shortly before the end of the mandatory rinse in Dis I to V (CDS: Dis I to IV). The hydraulics test has not been completed correctly, possibly caused by flow problems.</p>

- **Hydraulics test (check of V91 and valve 98) in systems without central delivery system**

<i>Error message</i>	<i>Description</i>
F14	Three minutes before the end of the mandatory rinse in Dis I to V. It was not possible to readjust the flow to 750 ml/min \pm 50 ml/min. V91 defective.
V91 Failure	Three minutes before the end of the mandatory rinse in Dis I to V. After V91 has opened, a flow > 950 ml/min failed to develop. V91 or valve V98 defective.
F14	Shortly before the end of the mandatory rinse in Dis I to V. The hydraulics test has not been completed correctly, possibly caused by flow problems.

- **Hydraulics test (check of V91, V99, V100, V130) in systems with BIBAG and without central delivery system**

The following requirements must be fulfilled to run the hydraulics test:

1. The test is run during the last 3 minutes of the mandatory rinse program only.
2. DIP switch 7 DIP array 2 on PCB LP 631 must be set to ON.

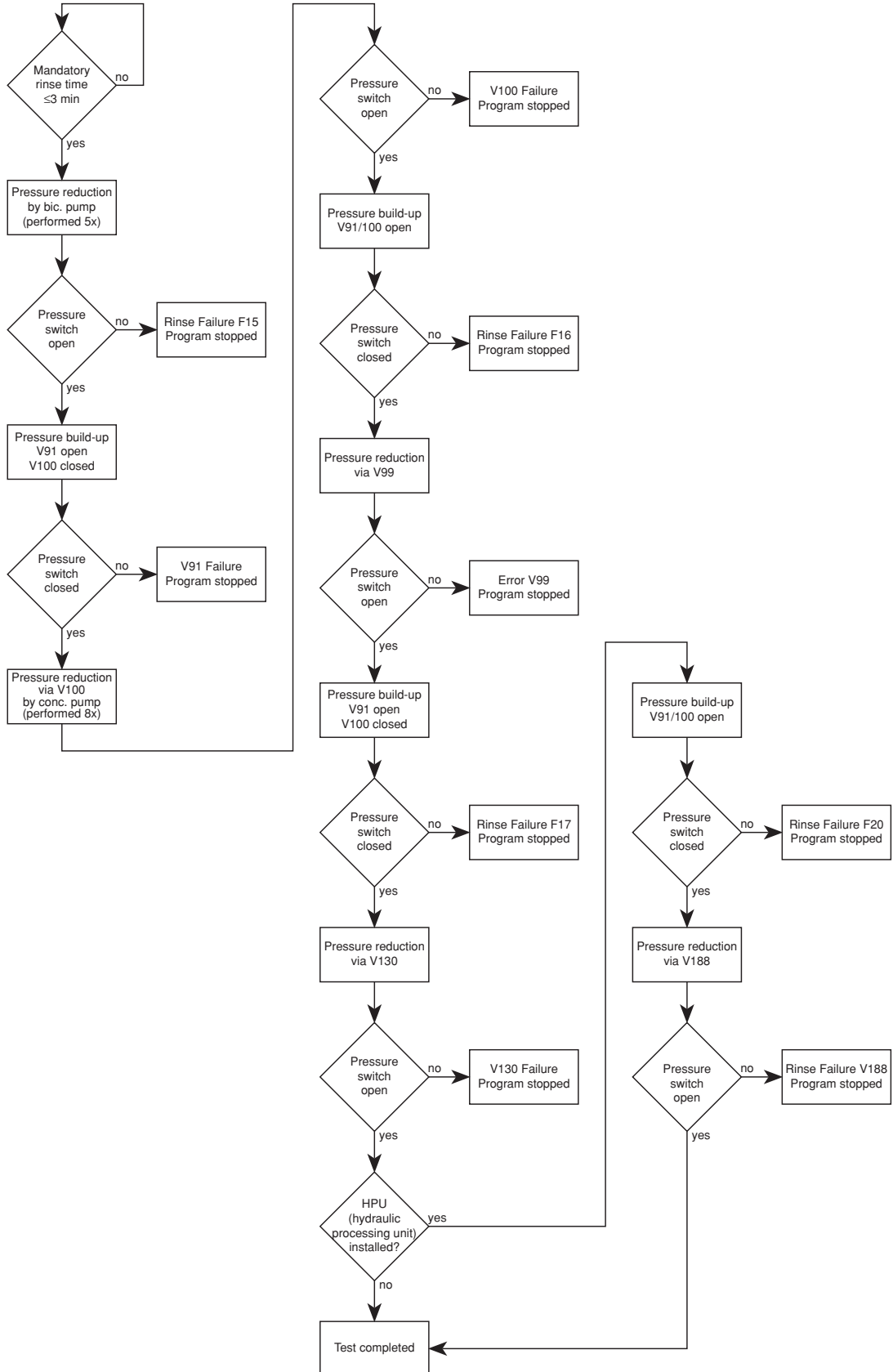

<i>Error message</i>	<i>Description</i>
Rinse Failure F15	<p>Three minutes before the end of the mandatory rinse in Dis I to V. DS (BIBAG pressure switch 134) could not be opened at the beginning of the test.</p> <ul style="list-style-type: none"> – Check pressure switch: Switching point: desired value: 130 mbar + 30 – Suction error of bicarbonate pump – V91 constantly electrically or mechanically open – V99/100 constantly electrically or mechanically closed
V91 Failure	<p>Three minutes before the end of the mandatory rinse in Dis I to V. It is impossible to build up pressure on DS (BIBAG pressure switch 134) via V91.</p> <ul style="list-style-type: none"> – Pressure switch fails to close mechanically: check switching point. – V91 fails to open electrically: P.C.B. LP 634: X634L/A12. – V91 fails to open mechanically (possibly clogged) – V130 electrically not closed: P.C.B. LP 634: X634L/ A4 – V130 fails to close mechanically (possibly clogged). – Bibag connector leaking (check O rings) – Sealing on the bicarbonate suction tube leaking. – Check acknowledgement of pressure switch on P.C.B. LP 633: X633L/A8. – V99 constantly electrically or mechanically open.
V100 Failure	<p>Three minutes before the end of the mandatory rinse in Dis I to V. It is impossible to build up pressure on DS (BIBAG pressure switch 134) via V100.</p> <ul style="list-style-type: none"> – V100 fails to open electrically: P.C.B. LP 634: X634L/C13. – V100 fails to open mechanically (possibly clogged). – V91 constantly electrically or mechanically open – Concentrate pump fails to pump. – Filter (148) clogged. – Pressure switch fails to open.
Rinse Failure F16	<p>Three minutes before the end of the mandatory rinse in Dis I to V. DS (BIBAG pressure switch 134) cannot be closed. V99 or V130 is leaking.</p> <ul style="list-style-type: none"> – V91 fails to open electrically or mechanically. – V99 constantly electrically or mechanically open – V130 constantly electrically or mechanically open – Sealing on the concentrate suction tube leaking. – Pressure switch fails to close.
V99 Failure	<p>Three minutes before the end of the mandatory rinse in Dis I to V. DS (BIBAG pressure switch 134) cannot be opened. V99 does not open.</p> <ul style="list-style-type: none"> – V99 fails to open electrically or mechanically. – V100 fails to open electrically or mechanically. – Pressure switch fails to open. – V91 electrically or mechanically open – Filter (149) upstream of V99 clogged

- Rinse Failure F17** Three minutes before the end of the mandatory rinse in Dis I to V. DS (BIBAG pressure switch 134) cannot be closed.
- V91 fails to open electrically or mechanically.
 - V130 electrically or mechanically open
 - V100 electrically or mechanically open
 - Pressure switch fails to close.
- V130 Failure** Three minutes before the end of the mandatory rinse in Dis I to V. DS (BIBAG pressure switch 134) cannot be opened.
- V130 fails to open electrically or mechanically.
 - Pressure switch fails to open.
 - Check tubing for bicarbonate suction line and bibag block.
 - Bicarbonate line squeezed at strain relief.
 - Narrowing in the reducer on the bibag connector
- Rinse Failure F 20** Impossible to close the pressure switch (134) via V91/100.
- V91 fails to open electrically or mechanically.
 - V130/V188 electrically or mechanically open.
 - Pressure switch fails to close.
- V188 Failure** The pressure on pressure switch (134) cannot be reduced via V188.
- V188 fails to open electrically or mechanically
 - Pressure switch fails to open
 - Check tubing for carbonate suction line and air separator block.
 - Concentrate line squeezed at strain relief.
- Rinse Failure F14** Shortly before the end of the mandatory rinse in Dis I to V. The hydraulics test has not been completed correctly, possibly caused by flow problems.

● **V39 test**

The following requirements must be fulfilled to run the V39 test:

1. The test is run during the last minute of the mandatory rinse program only.
2. DIP switch 5 DIP array 2 on PCB LP 632 must be set to OFF.

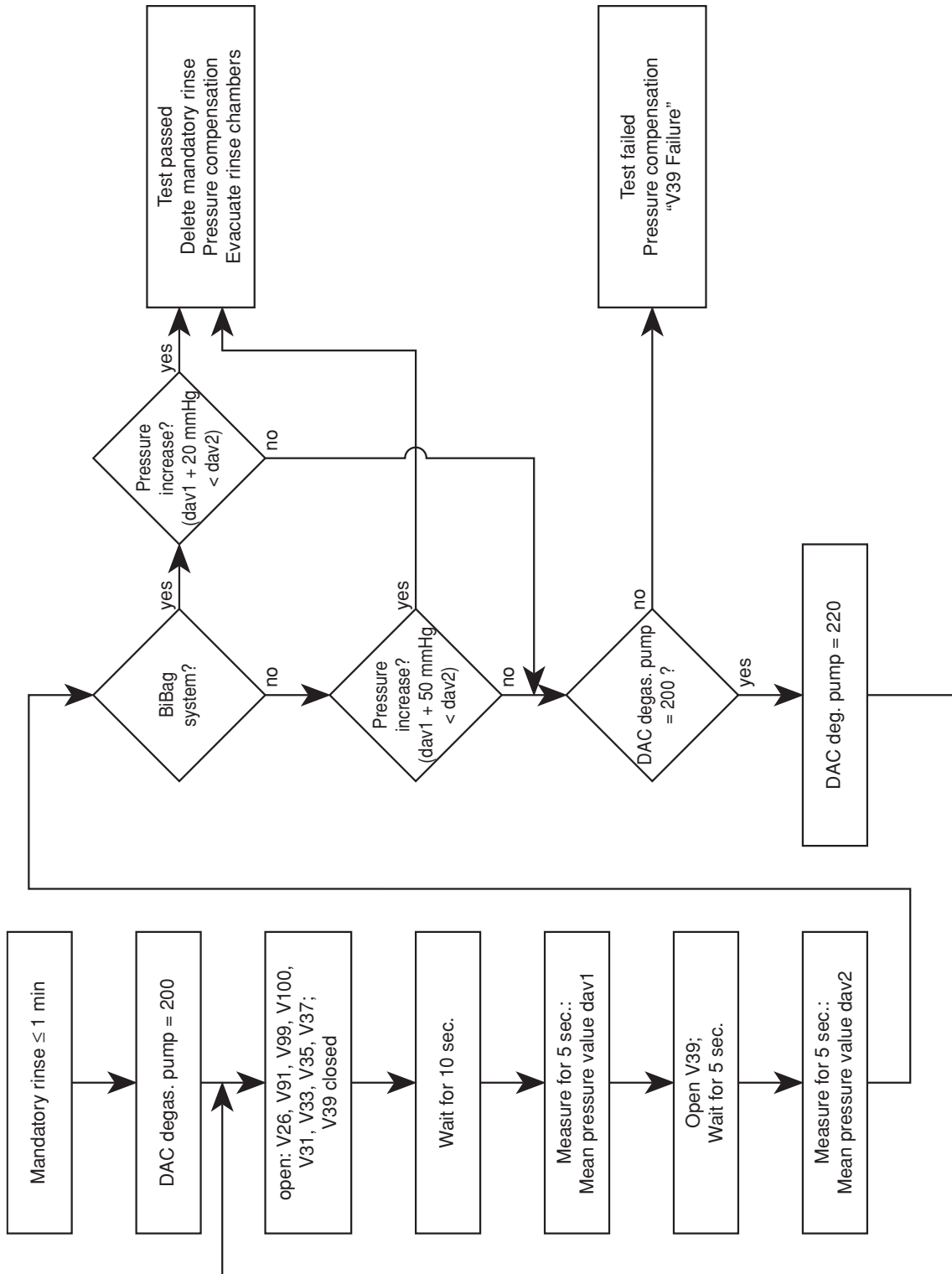

Error message

Description

V39 Failure

On opening V39 a difference in pressure (averaged value V39 open – averaged value V39 closed) is detected on the dialysate pressure transducer (182):

Standard system: < 50 mmHg

bibag system: < 20 mmHg

- V39 fails to open / close electrically or mechanically (possibly hydraulic processing unit defective).
- It is impossible to re-adjust the degassing pump (P.C.B. LP 634).
- V91, V99, V100 fail to open electrically or mechanically.
- Dialysate pressure transducer (182) defective or not calibrated (possibly HPU P.C.B. LP 941 defective)
- Filter 210 (upstream of degassing pump) clogged.

- **Further messages which may be displayed before or during a cleaning program**

<i>Error message</i>	<i>Description</i>
Blood Sensed by OD	Start of a cleaning program in RI I to II, HR I to III, Dis I to V. The optical detector in the air detector module recognizes blood.
Shunt Cover open	Start of a cleaning program or during a cleaning program in RI I to II, HR I to III, Dis I to V. The shunt interlock is not closed.
Dialines not conn	Start of a cleaning program in RI I to II, HR I to III, Dis I to V. The dialysate couplings are not connected to the shunt interlock.
No LD alarm	Priming of the blood line system in RI I to II, HR I to III, Dis I to V. The drip chamber in the air detector module does not recognize any alarm.
Conc line not conn	Start of a cleaning program in RI I to II, HR I to III, Dis I to V, or end of the disinfectant suction phase in Dis V. The concentrate plug is not connected to the rinse chamber. Reconnect the concentrate plug to the rinse chamber.
Bic line not conn	Start of a cleaning program in RI I to II, HR I to III, Dis I to V, or end of the disinfectant suction phase in Dis V. The bicarbonate plug is not connected to the rinse chamber. Reconnect the bicarbonate plug to the rinse chamber.
Voltage Failure	During a cleaning program in RI I to II, HR I to III, Dis I to V. The 24-V/12-V supply voltages are drifting. This error can be acknowledged for 8 sec by pressing the respective program key.
CPU-II failed	During a cleaning program in RI I to II, HR I to III, Dis I to V. The watchdog relay has dropped. Communication (RxD or TxD) may be disturbed.
High temperature	During a cleaning program in RI I to II, HR I to III, Dis I to V. Temperature > 41 °C; > 90 °C during HR; > 91 °C during IHR. The system continues to run. The alarm tone can be acknowledged. Upon error elimination, the message is automatically cleared.
Low temperature	During a cleaning program in RI I to II, HR I to III, Dis I to V. Temperature < 33 °C; < 78.5 °C during HR. The system continues to run. The alarm tone can be acknowledged. Upon error elimination, the message is automatically cleared.

Water alarm	<p>During a cleaning program in RI I to II, HR I to III, Dis I to V. The float switch transmits the “no water available” message for more than 10 seconds. The balancing chamber has stopped; V41 is permanently open. Upon error elimination, the message is automatically cleared.</p>
Water alarm	<p>During a cleaning program in RI I to II, HR I to III, Dis I to V. For more than 30 seconds, the float switch fails to signal that water is required (not applicable to recirculation programs). The system continues to run. Upon error elimination, the message is automatically cleared.</p>
Flow alarm	<p>During a cleaning program in RI I to II, HR I to III, Dis I to V. A current rise pulse is not recognized for more than 12 seconds. The system continues to run at “Eigentakt” (10 seconds). Upon error elimination, the message is automatically cleared.</p>
Upper Flow Alarm	<p>During a cleaning program in RI I to II, HR I to III, Dis I to V. The cleaning flow increases to > 1000 ml/min. The program has stopped. The error can be acknowledged by pressing the respective cleaning program key.</p>
UF-Pump failed	<p>During a cleaning program in RI I to II, HR I to III, Dis I to V. The UF pump has stopped or the rate deviates (2800 ml/h < UFR < 6000 ml/h). The program has stopped. The error can be acknowledged by pressing the respective cleaning program key.</p>
UF-Pump 2 failed	<p>During a cleaning program in RI I to II, HR I to III, Dis I to VI. The UF2 pump has stopped (applicable only to systems with 4008 HDF). The error can be acknowledged by pressing the respective cleaning program key.</p>
Dial. Valve failed	<p>During a cleaning program in RI I to II, HR I to III, Dis I to V. V24 or V24B is closed although it should be open. The program has stopped. The error message can be acknowledged by pressing the respective program key.</p>
Bypass Valve failed	<p>During a cleaning program in RI I to II, HR I to III, Dis I to V. V26 is closed although it should be open. The program has stopped. The error message can be acknowledged by pressing the respective program key.</p>

V102 Failure	During a cleaning program in RI I to II, HR I to III, Dis I to V. V102 has been opened electrically. 24 V are switched off. The error cannot be acknowledged.
V104 Failure	During a cleaning program in RI I to II, HR I to III, Dis I to V. V104 has been opened electrically. 24 V are switched off. The error cannot be acknowledged.
HDF-Pump failure	During a cleaning program in RI I to II, HR I to III, Dis I to V. The HDF pump has stopped, or the speed deviates (rated value: 400 ml/min, actual value: ≤ 300 ml/min; rated value: 150 ml/min, actual value: ≤ 100 ml/min). The error message can be acknowledged for one complete cleaning program run by pressing the respective program key. The prompt: "Are you sure ?" is displayed.
Float-Switch Failure	During a disinfectant program in the suction phase in Dis I to V (CDS: Dis I to IV). The lower switching point of the float switch is not reached within 20 sec. The program has stopped.
Connect Disinfectant	Disinfectant suction phase in Dis V. Request to connect the disinfectant.
Press CONFIRM key	Disinfectant suction phase in Dis V. After the disinfectant has been connected, the Confirm key on the menu panel must be pressed to start the suction procedure. The program has stopped.
Please Wait	Disinfectant suction phase in Dis V. Disinfectant is drawn in via the concentrate pump.
Disinfectant empty ?	Disinfectant suction phase in Dis I to V. Dis V: After the disinfectant has been drawn in, the float switch does not recognize any fluid. Dis I to IV, Dis VI: The V84 monitoring unit does not recognize any conductivity.
Disinf-Temp. too high	Transition to disinfection in Dis I to V. Temperature at the end of the rinse-free procedure > 40 °C. Again and again, the rinse-free procedure is prolonged by 1 minute. An audible warning is sounded after 4 minutes. The message is automatically cleared, and it cannot be acknowledged.

Rinse required !	During stored mandatory rinse in Dis I to V. The mandatory rinse has been interrupted (e.g. the system has been switched off).
Rinse after Disinf.	Selection of a cleaning program, although a mandatory rinse has been requested in HR. A disinfection program has been stopped and subsequently a rinsing or hot rinsing program started.
Power Failure	During a cleaning program in RI I to II, HR I to III, Dis I to V. Line voltage failed.
BIBAG connect. open	Upon start of a cleaning program in RI I to II, HR I to III, Dis I to V. The BIBAG connector is not closed (cap not attached).
Heater error	During the CDS rinsing phase at the end of a hot rinsing program or a hot disinfection program in CDS: HR I to III, Dis II to IV. The heater signal (P.C.B. LP 633: X633R/A26) is not changing for > 40 sec.
Accumulator empty!	Battery voltage <17.2 V \pm 2.5 % Only in the event of a power failure during the cleaning programs. If the voltage drops below 17 V, the system will switch off.

1.1.5 Error messages after turning power on

<i>Error message</i>	<i>Description</i>
EPROM ERROR	System error. Check the plugs and the EPROM for proper connection. Replace the EPROM, if necessary.
BRAM_#_XXXX_XXXX_XXXX	System error. Switch the system off and on again. Check the plugs and the BRAM of P.C.B. LP 631 and P.C.B. LP 632 for proper connection. Replace the BRAM, if necessary. Then recalibrate.
RAM ERROR	System error. Switch the system off and on again. Check the plugs and the RAM for proper connection. Replace the RAM, if necessary.
Keyboard Error	Short-circuit on the keyboard. Switch the system off and on again. Check the plugs for proper connection. Possible short-circuit on the keys. Replace the front panel, if necessary.
Watchdog Error	This error message can only be displayed shortly after switch-on. Switch the system off and on again. Check the WD relay and components. Check CPU2/CPU1. Check the plug connectors on the monitor.
XX (not calibrated)	NOVRAM error upon test request. Switch the system off and on again. Recalibrate the function indicated. Replace the NOVRAM, if necessary.
NTC109 switched off	No valid value has been filed during start in the NOVRAM. The difference in temperature between NTC 109 and NTC 3 is too large. Switch off NTC 109 in the setup menu, or recalibrate the temperature.

1.1.6 Error messages during dialysis

<i>Error message</i>	<i>Description</i>
Voltage Failure	<p>The 24-V/12-V supply voltages are drifting. The system enters the safe state and must be switched off/on.</p> <ul style="list-style-type: none">– The 12-V or 24-V operating voltage is outside of the permissible range: 24 V: > 26 V / < 22.5 V 12 V: > 13.5 to 15 V / < 10.5 V– Check the power supply unit.– Power supply unit okay: Check the voltages applied to P.C.B. LP 633: +12 V: X633R/A, C31 +24 V: 24V_EM: X633L/B20
24 V Switched Off	<p>The 24-V supply voltage has fallen below 5 V. The system enters the safe state and must be switched off/on.</p> <ul style="list-style-type: none">– Check the power supply unit.– Power supply unit okay: Check the voltages at P.C.B. LP 633: +24V_EM: X633L/B20– Remove all plug-in modules. As soon as the system is running: reconnect each plug-in module individually with the system switched off; determine the defective module and repair it.– Completely loosen the hydraulic compartment connections. <i>Caution:</i> J1 must now be fitted on P.C.B. LP 630 since, without it, the system would not be able to perform the watchdog test. Be absolutely sure to remove the jumper again for hemodialysis operation. With the system running, check the short circuit in the hydraulic compartment for 24-V supply and the valves and pumps for short circuit.
CPU-II failed	<p>CPU2 fails to communicate via the serial interface. The system enters the safe state and must be switched off/on.</p> <ul style="list-style-type: none">– The software versions of CPU1 and CPU2 are mismatching.– Hardware defect on CPU2.
Profile time diff.	<p>Deviation in time between CPU1 and CPU2. The error message is emitted 60 seconds after the start of the profile.</p> <ul style="list-style-type: none">– The clock module on CPU1 (IC14) is defective; or calibrate the time in case of layout < D.
Cyclical PHT F01	<p>Balancing error.</p> <ul style="list-style-type: none">– System leakage.– Applicable to Diasafe systems: On CPU II, the DIP switch array 2, switch 1, is not set to “ON”.
Cyclical PHT F02	<p>Balancing error.</p> <ul style="list-style-type: none">– System leakage.– Applicable to Diasafe systems: On CPU II, the DIP switch array 2, switch 1, is not set to “ON”.

Cyclical PHT F03	IC1 or IC3 on P.C.B. LP 632 is defective, or system leakage.
Cyclical PHT F04	It was not possible to complete the test within a specific time interval.
V84 faultiness !	<p>Conductivity is recognized at the V84 electrodes. This error message is emitted for the first time at the end of the T1 test. The error can be acknowledged for the duration of one hemodialysis procedure by pressing the Dialysis Start key. It is, however, not possible to switch off the flow (Bergström-/ISO-UF operating mode). Should the error occur during Flow OFF, the flow is switched on automatically.</p> <ul style="list-style-type: none"> – First of all, it must be verified whether a Rinse Failure F01, F02 or F03 occurred during the previous disinfection procedure (see listing of cleaning program errors). Should this be the case, a disinfection program I to IV (not Dis V) must be completed correctly. The problem can also be corrected using the calibration program, NOVRAM menu item (Reset V84). – Should this not be possible, the error memory of the system can be read out. – Should this neither be possible, the test described below can be performed: Remove the disinfectant. Switch the system off and on again. Perform or skip the T1 test. Should the error message be displayed again at the end of the test, it was generated by a Rinse Failure F01, F02 or F03 and can be cleared only by taking the measures described above. Should the message not be displayed again, a second test can be performed: Reconnect the disinfectant. Set the UF rate and switch on the UF unit. Should the error occur at this moment, there is a leakage on V84 (see listing of cleaning program errors).
Shunt Cover open (temporarily)	<ul style="list-style-type: none"> – P.C.B. LP 633 C24 (100n) temporarily short-circuited. – Shunt interlock defective (check switches).
Voltage Failure (temporarily)	P.C.B. LP 633 C84 (100n) temporarily short-circuited.
UF1 volume - Error UF2 volume - Error	<p>Failure to pass the test for an UF pump. The fill volume for the secondary air separator is outside the tolerance of 100 ml \pm4 ml. Possible cause:</p> <ul style="list-style-type: none"> – The affected UF pump fails to deliver correctly (not calibrated or mechanical defect) – If the test result is >104 ml, the problem can also be caused by air coming from a poorly deaerated dialyzer.

F327 UF-failure	Pause between two UF1 pump strokes less than 220 ms. Possible cause: – CPU-1 defective
F328 UF-failure	Pulse time of one UF1 pump stroke less than 180 ms. Possible cause: – Controlling monoflop on LP 634 defective
F329 UF-failure	Pulse time of one UF1 pump stroke exceeds 500 ms Possible cause: – Controlling monoflop on LP 634 defective.
F330 UF-failure	Pick-up time of the UF1 pump exceeds 10 sec. Possible cause: – Controlling output stage on LP 634 defective.
F331 UF-failure	Theoretical/actual rate of the UF1 pump deviates by more than $\pm 10\%$. Possible cause: – System error
F332 UF-failure	UF1 pump stopped for more than the maximum time period. Possible cause: – Controlling output stage on LP 634 defective. – UF pump interruption – System error
F333 UF-failure	Volume changes by more than 10 ml during prescribed standstill (only monitored if OD is dark). Possible cause: – System error
F334 UF-failure	Pause between two UF2 pump strokes less than 220 ms. Possible cause: – CPU-1 defective
F335 UF-failure	Pulse time of one UF2 pump stroke less than 180 ms. Possible cause: – Controlling monoflop on LP 634 defective.
F336 UF-failure	Pulse time of one UF2 pump stroke exceeds 500 ms. Possible cause: – Controlling monoflop on LP 634 defective.
F337 UF-failure	Starting time of the UF2 pump exceeds 10 sec. Possible cause: – Controlling output stage on LP 634 defective.
F338 UF-failure	Desired/actual rate of the UF2 pump deviates by more than 10%. Possible cause: – System error
F339 UF-failure	UF2 pump stopped for more than the maximum time period. Possible cause: – Controlling output stage on LP 634 defective. – UF pump interruption – System error

F340 UF-failure	UF2 volume change more than 10 ml although UF is switched off. Possible cause: – System error
F341 UF-failure	Mechanical UF1 pump failure. Possible cause: – Broken spring – Contaminated filter
F342 UF-failure	Mechanical UF2 pump failure. Possible cause: – Broken spring – Contaminated filter
F343 UF-failure	UF1/UF2 pump volume difference Possible cause: – Delivery volume altered
F350 UF-failure	A difference of more than 100 ml between the CPU1 and the CPU2 volume is detected during an UF data transfer after turning the UF unit on. Possible cause: – System error
F351 UF-failure	CPU2 could not detect plausibility of the CPU1 UF parameters. Possible cause: – System error
F352 UF-failure	CPU2 UF deviation compared to the theoretical UF target volume. Possible cause: – System error
F354 UF-failure	UF rate exceeds the maximum rate allowed. Possible cause: – System error
F361 UF-failure	CPU1 sent the UF parameter set to CPU2 and has not received a release from CPU2 after a timeout of 30 s. Possible cause: – System error
F363 UF-failure	CPU2 did repeatedly not receive a complete UF parameter set. Possible cause: – System error
F364 UF-failure	UF1 volume change although the UF goal has already been reached. Possible cause: – System error
F370 UF-failure	UF2 volume change although the UF goal has already been reached. Possible cause: – System error

- **HPU error**

<i>Error message</i>	<i>Description</i>
HPU Error F00	The HPU logs off with index STATUS_ER; no bit is set in the error bit field. <ul style="list-style-type: none">– Problem on P.C.B. LP 941– Problem on CAN distributor board– Problem on P.C.B. LP 763– Problem on P.C.B. LP 630
HPU Error F01	The cyclic communication has failed for more than 2 seconds. <ul style="list-style-type: none">– System error
HPU Error F02	The response to an event violated the time-out. <ul style="list-style-type: none">– System error
HPU Error F03	An error occurred in the program sequence. <ul style="list-style-type: none">– System error
HPU Error F04	Voltage drop (24V_SW) during HPU operation. <ul style="list-style-type: none">– 24V voltage supply on P.C.B. LP 941 failed (watchdog dropped).
HPU Error F05	Watchdog test failed to be passed. <ul style="list-style-type: none">– Watchdog circuit on P.C.B. LP 941
HPU Error F06	Reference voltage monitoring detected an error. <ul style="list-style-type: none">– Reference voltage circuit on P.C.B. LP 941 is defective.
HPU Error F07	The HPU was logged off by the monitor. Will not be displayed since CPU1 has already stopped the communication. <ul style="list-style-type: none">– System error
HPU Error F08	General valve malfunction: may occur in HPU SW 2.01 or 3.00. (Software versions before evaluation of the HPU errors). <ul style="list-style-type: none">– System error
HPU Error F09	Malfunction of the compressor (185) <ul style="list-style-type: none">– MV43 defective or activated– Compressor 185 defective or activated– Error on P.C.B. LP 941
HPU Error F10	Malfunction of valve MV39 <ul style="list-style-type: none">– MV39 defective or activated– Error on P.C.B. LP 941
HPU Error F11	Malfunction of test valve (183) <ul style="list-style-type: none">– MV43 defective or activated– MV183 defective or activated– Error on P.C.B. LP 941

- HPU Error F12** Malfunction of evacuation valve (188)
- MV188 defective or activated
 - Error on P.C.B. LP 941
- HPU Error F13** Malfunction of retentate valve (189)
- MV189 defective or activated
 - Error on P.C.B. LP 941
- HPU Error F14** Defective component on P.C.B. LP 941
- Error on P.C.B. LP 941
- HPU Error F15** Error in the HPU software. Valves are activated incorrectly.
- System error
- HPU Error F98** Proceeding to the T1 test is not allowed after restart.
- System error
- HPU Error F99** HPU fails without logging off.
- Damaged cable or similar problem
 - HPU logged off by CPU1
 - CRC error in the transfer HPU → CPU1
 - BVM is connected via CAN and software <3.20 is installed in the BVM.
 - The VDE test was performed directly after turning the system on. Turn the system on at least 2 minutes before the test.

- **ONLINE module errors**

<i>Error message</i>	<i>Description</i>
ONL Error F00	Online module error
ONL Error F01	Watchdog error
ONL Error F02	Watchdog error
ONL Error F03	Watchdog error
ONL Error F04	Error in the program sequence
ONL Error F05	+24V_WD dropped to less than 17V or was switched off
ONL Error F06	Time-out of the communication watchdog exceeded
ONL Error F07	A transmission from the module was not confirmed by the dialysis system
ONL Error F08	General valve error
ONL Error F09	T1 test skipped
ONL Error F10	T1 test for ONLINEplus failed to be passed
ONL Error F11	Reference voltage is outside the tolerance
ONL Error F12	CRC error
ONL Error F13	EEPROM error
ONL Error F14	The monitor disabled the ONLINEplus module
ONL Error F16	Valve error ONL1
ONL Error F17	Valve error ONL2
ONL Error F18	Valve error ONL3

1.2 Functional description of the modules

1.2.1 Blood pump (arterial)

The blood pump ensures a sufficient blood flow in the extracorporeal blood circuit. It is absolutely necessary that sterility is maintained and that the blood is prevented from becoming contaminated.

The blood pump is designed as roller pump provided in an exchangeable plug-in module integrated in the hemodialysis system. The blood line is installed between a stator, which, with its rolling surface bent in a circle, represents a thrust bearing, and a rotor, which is provided with rollers and pivoted in the stator. The pressure of the rollers causes the development of a narrow or seal. If the rollers are moving in the direction of delivery, the blood is pushed in this direction.

A microprocessor controls the stepper motor with quartz accuracy, depending on the selected delivery rate, the set line diameter, and the monitor signals.

The pressure measuring equipment comprises a piezo-resistive pressure transducer. The pressure-proportional voltage is indicated on the monitor on a quasi-analog LED scale.

Functions of the blood pump:

- RAM and CRC test after turning power on,
- control and monitoring of the function by a dual processor system,
- emergency switchoff in case of an alarm: stop recognition (15 or 30 sec),
- setting of the speed to 180 ml/min during priming,
- measurement of the arterial pressure or the Single-Needle pressure (depending on the model concerned),
- semi-automatic loading and unloading of the line segment.

Error messages:

- E.01 Line diameter outside the permissible range
- E.02 Undefined hex switch position
- E.03 Uncalibrated arterial pressure transducer
- E.04 Run-time monitoring error during SN operation
- E.05 SN stroke volume outside the permissible range
- E.06 SN pressure thresholds outside the range of values of the A-D converter
- E.08 Stop alarm
- E.09 Error during A-D conversion
- E.12 Rotary monitoring error (Hall sensor)
- E.13 Monitoring error with regard to current sensing resistors
- E.14 Monitoring error with regard to current sensing resistors
- E.15 Speed monitoring error

1.2.2 Blood pump (Single-Needle), optional

Essentially, the blood pump (Single-Needle) is identical with the arterial blood pump. The difference lies in the Single-Needle control. During SN operation, the pressure outlet of the compliance vessel is connected to the pressure connector of the SN pump. The pressure transducer is protected by a hydrophobic filter both in the external and the internal tubing system.

The SN stroke volume can be set within a range from 10 ml to 50 ml in increments of 5 ml.

To adjust it, first press the **Start/Stop** key and the ▼ key simultaneously. Then change the value by using the ▲ and ▼ keys.

The lower changeover point is fixed to 75 mmHg.

The upper changeover point depends on the stroke volume:

Stroke volume (ml)	10	15	20	25	30	35	40	45	50
Changeover point (mmHg) ± 7 mmHg	110	130	150	172	195	219	244	270	299

1.2.3 Heparin pump

Since the blood flows through an extracorporeal circuit during hemodialysis, coagulation would occur within a short time. The heparin pump allows continuous heparinization of the blood causing the coagulation time to be prolonged. Since the heparin volume required during hemodialysis depends on the respective patient concerned, it must be determined by the attending physician.

A syringe plunger is moved by a drive rod, which is connected to a threaded spindle via a sliding block. A microprocessor-controlled stepper motor causes the spindle to rotate. Depending on the type of activation, the plunger moves up or down. A Hall sensor indicates the upper end position of the plunger. The protective system of the pump comprises a speed monitoring unit (slotted disc with optical sensor) as well as a motor current monitoring unit.

The different syringe types can be selected by means of a coding switch:

- 0 20 ml B&D syringe
- 1 30 ml Fresenius syringe
- 2 50 ml Fresenius syringe
- 3 10 ml B&D syringe
- 4 30 ml B&D syringe
- 5 50 ml B&D syringe
- 6 20 ml Terumo syringe
- 7 30 ml Terumo syringe
- 8 50 ml Terumo syringe
- 9 20 ml JMS syringe
- A 20 ml Nipro syringe
- B – F not used



Caution

Do not change the coding switch position during operation.

Function of the heparin pump:

- RAM and CRC test after turning power on,
- delivery rate adjustable from 0.1 ml to 10 ml in increments of 0.1 ml,
- delivery time preselection (stopwatch) adjustable from 1 min to 9 h 59 min,
- bolus administration.

Error codes:

E01	<i>Hardware error, gate array defective</i>
E02	<i>Hardware error, reset by spike or test alarm</i>
E03	Checksum error, data loss
E04	First start-up
E05	Incorrect hex switch position
E06	Missing or incorrect data for the variable syringe
E07	Selection of wrong syringe
E11 to E13	<i>Step error</i>
E12	Overdelivery during fast return
E14 to E15	<i>Error in direction of rotation</i> (software not equal to hardware!)
E16	<i>Software error</i>
E19	<i>Optical sensor error</i> (stop of syringe holder or optical sensor defective)
E20	<i>Error in direction of rotation</i>
E33	<i>Step error</i> (impermissible range)
E37	<i>Slotted disc error</i>
E40	<i>Division error</i> (division by zero)
E41 to E42	<i>Error in direction of rotation</i> (fast return)
E43 to E44	<i>Error in direction of rotation</i> (slow return)
E45 to E46	<i>Error in direction of rotation</i> (fast advance)
E47 to E48	<i>Error in direction of rotation</i> (slow advance)
E49	<i>Step error</i> (underdelivery during slow advance)
E50	<i>Step error</i> (underdelivery during slow return)
E51	<i>Step error</i> (overdelivery during fast advance)
E55	<i>Error in step counting</i> (optical sensor defective or mechanics too sluggish; no pulses from the slotted disc)
E56	<i>Error in step counting</i> (more than 8 pulses during transition of the slotted disc; the slotted disc is oscillating)
E90	<i>Display error</i>

1.2.4 Air detector

The penetration of air into the patient's extracorporeal blood circuit may cause an air embolism. In order to catch limited amounts of air and to separate accompanying air bubbles, the venous blood line is expanded (venous drip chamber). A major task of the air detector is to monitor the filling level in the venous drip chamber.

Ultrasonic air detector

The protection system against air infusion uses the method of ultrasonic transmission. Ultrasonic converters are attached on either side of the venous bubble catcher. At periodic intervals of approx. 90 ms, a transmitting resonator generates attenuated ultrasonic vibrations at a natural resonance of approx. 90 kHz, which are absorbed by a receiving resonator. The amplitude of the signal received is dependent upon the medium between the converters. Its value is at its minimum with the bubble catcher empty (air) and at its maximum with bubble-free fluids. The amplitude decreases with increasing air content (foam). The signal path is fail-safe up to and including the receiving resonator, i.e. the failure of any component always leads to a smaller amplitude and, thus, to an alarm. Starting at the receiving resonator, the signal voltage is always sent onto two independent receiver paths. As soon as the signal is too weak, one of these receiver paths causes the blood pump to stop and the other the venous line clamp to close.

The ▲ and ▼ keys are used to both raise and lower the blood level in the venous bubble catcher. As long as the ▲ key is pressed, the venous line clamp closes. The vent valve in the air detector module opens, and the blood level rises. The blood pump runs at reduced speed (180 ml/min). As long as the ▼ key is pressed, the venous line clamp remains open. The vent valve in the air detector module opens, the ventilation pump is running, and the blood level sinks. The blood pump runs at the preselected speed.

Optical detector

The optical detector serves to detect if there is blood or saline solution or air in the venous return line downstream of the bubble catcher. In the hemodialysis system, the hemodialysis phase is defined by presence of a dark medium and the preparation phase by presence of a clear medium.

Venous pressure measurement

The venous pressure measuring equipment comprises a piezo-resistive pressure sensor provided on the P.C.B. with following operational amplifier. The pressure-proportional output voltage is supplied onto the logic P.C.B. in the monitor. There, the pressure is indicated on a quasi-analog LED scale, and the transmbrane pressure is computed by determining the difference between the dialysate pressure and the venous pressure.

Legend

2	Temperature sensor	97	Air separating pump
3	Temperature sensor	98	Rinse valve
4	Temperature sensor (OCM option)	99	Rinse valve
5	Float switch	100	Rinse valve
6	Level sensor	102	CDS, concentrate valve
7	Conductivity cell	104	CDS, bicarbonate valve
8	Blood leak detector	109	Temperature sensor
9	Pressure transducer	110	Conductivity cell (OCM option)
10	Reed contact for concentrate	111	Hydrophobic filter (advanced hydraulics)
12	Reed contact for bicarbonate	112	Vent valve (advanced hydraulics)
21	Flow pump	114	Dialysate filter
22	UF pump	115	Disinfection valve sensor
23	Concentrate pump	116	Fluid sample valve
24	Dialyzer valve 1	117	Check valve (concentrate)
24b	Dialyzer valve 2	118	Check valve (bicarbonate)
25	Bicarbonate pump	119	Filter (concentrate)
26	Bypass valve	120	Filter (bicarbonate)
29	Degassing pump	121	CDS, concentrate connector
30	Outlet valve	122	CDS, bicarbonate connector
31	Balancing chamber valve 1	123	Pressure switch for V102
32	Balancing chamber valve 2	124	Pressure switch for V104
33	Balancing chamber valve 3	125	Temperature compensation plate
34	Balancing chamber valve 4	130	Bibag drain valve
35	Balancing chamber valve 5	132	Bibag conductivity cell
36	Balancing chamber valve 6	133	Bibag temperature sensor
37	Balancing chamber valve 7	134	Bibag pressure transducer
38	Balancing chamber valve 8	136	Bibag connector
39	Negative pressure valve	137	Bibag microswitch 1
41	Water inlet valve	138	Bibag microswitch 2
43	Fill valve	148	Filter (rinse valve 100)
54	Heater rod	149	Filter (rinse valve 99)
61	Pressure reduction valve	151	Orifice
63	Filter/water inlet	182	Pressure transducer 2 (advanced hydraulics)
65	Loading pressure valve	183	Test valve (advanced hydraulics)
66	Heater block	184	Hydrophobic filter
66a	Water inflow chamber	185	Compressor (advanced hydraulics)
66b	Heater rod chamber	188	Evacuation valve
66c	Float switch chamber	189	Retentate valve
68	Balancing chamber	190	Online filter (Online plus option)
71	Filter/concentrate	191	Online 3 valve (Online plus option)
72	Filter/bicarbonate	192	Online 2 valve (Online plus option)
73	Filter/dialysate	193	Online 1 valve (Online plus option)
74	Filter/UF	194	Rinse port (Online plus option)
75	External flow indicator	195	Substitute port (Online plus option)
76	Filter/fill valve	201	Concentrate air separator
77	Heat exchanger	202	Concentrate level sensor
78	Relief valve	203	Bicarbonate air separator
84	Disinfection valve	204	Bicarbonate level sensor
85	Disinfection connector	205	Concentrate / bicarbonate mixing point
86	Recirculation valve	210	Filter
87	Drain valve		
88	Multifunction block		
88a	Degassing chamber		
88b	Secondary air separator		
88c	Primary air separator		
89	Degassing orifice		
90a	Concentrate rinse chamber		
90b	Bicarbonate rinse chamber		
91	Rinse valve		
92	Vent valve		
94	Concentrate suction tube		
95	Bicarbonate suction tube		

Hydraulics measuring points

- A Reduced water inlet pressure
- B Loading pressure
- C Pressure of flow pump
- D Pressure of degassing pump

1.3.1 Description of the hydraulic unit

As soon as the inlet valve (41) opens, the water flows through the pressure reducing valve (61) into the chamber (66a) of the heater block and across the heat exchanger (77) into the heater rod chamber (66b).

The concentrate pump (23) admixes concentrate to the inflowing water per balancing chamber phase.

The vent tubing prevents pressure from building up in chambers b and c. In the hot rinse mode, the developing vapor can escape through the vent tubing.

While it is rising, the fluid is warmed up to the preset temperature by the heater (54). The heater is controlled by the temperature sensor (2).

From chamber b, the dialysate flows into the chamber (66c). Incorporated in this chamber is a float switch (5), which controls the solenoid valve (41), thus ensuring the correct fluid level.

The degassing pump (29) draws in the dialysate via the degassing orifice (89). This generates a negative pressure of approx. 0.8 bar.

In the lines and the following chamber (88a), the dialysate is degassed to a level which is sufficient for hemodialysis.

Via the degassing pump (29), dialysate and released air are directed tangentially into the primary air separator (88c), where air bubbles and the airless dialysate are separated. The air accumulates at the top of the chamber (88c). Then, together with the recirculation flow and via the loading pressure valve (65) as well as the chamber (66c), the air escapes into the atmosphere.

Chamber 88c is provided with a separating disc (standard hydraulics only), which serves to prevent bicarbonate, if added, from being recirculated via the heater rod chamber (66b).

At the bottom of chamber 88c, the degassed dialysate is pressed out and into the balancing chamber (68) by means of the loading pressure.

Together with the eight solenoid valves (31 to 38), the balancing chamber (68) constitutes the balancing system. Each of the two sections of the balancing chamber comprises two compartments separated by an elastic membrane each. Hence, there are two chambers with four spaces:

- **F1** and **F2**: fresh fluid
- **A1** and **A2**: waste fluid (used)

As soon as one of the chambers (A1 or A2) is filled with dialysate, the solenoid valves are reversed in groups of four. The valves are reversed by the electronic evaluation of the current rise pulse of the drive motor of the pump (21), which receives this pulse upon membrane abutment. Within the filling phase, F1 or F2 is filled with fresh dialysate by means of the loading pressure. In order to obtain a continuous flow, a second chamber is switched parallel to the first chamber. The second chamber is operated at an inverse sequence.

Each time the chamber is changed over (maximum deflection of the membrane), all valves are closed for approx. 100 ms (dead time).

From the balancing chamber, the dialysate flows through the conductivity cell (7) with integrated temperature sensor (3). The measured conductivity values are indicated on the monitor in ms/cm, related to 25 °C.

The temperature sensor (3) has the following functions:

- temperature compensation of the conductivity display,
- indication of the dialysate temperature.

Should the actual values (temperature or conductivity) of the dialysate exceed or fall below the limit settings, the bypass valve (26) opens, and the dialyzer valve (24) is closed. The system is now in the bypass mode. The dialysate is discharged into the drain not via the dialyzer, but via the secondary air separator (88b) and the balancing chamber (68).

If the actual conductivity and temperature values of the dialysate are within the set limits, the dialyzer valve (24) opens. The valve (26) is closed. The dialysate flows to the dialyzer.

After the dialyzer, the dialysate which is now loaded with the substances usually eliminated with the urine flows into the secondary air separator (88b) via a filter (73), the valve (24b) and the blood leak detector (8). The secondary air separator (88b) comprises the pressure transducer (9) and the level sensor (6).

With a hematocrit of 0.25, blood losses of 0.5 ml per minute are recognized in the dialysate by the blood leak detector.

Together with the venous back pressure, the signal of the pressure transducer (9) is evaluated and indicated on the monitor as TMP. The fluid level in the secondary air separator (88b) is monitored by the level sensor (6). Due to the secondary air separator (88b), only airless dialysate is always delivered into the balancing chamber (68). Any presence of air bubbles in the balancing chamber (68) would cause balancing errors.

The dialysate is pressed into the balancing chamber (68) by the flow pump (21). As mentioned above, the balancing chamber valves are reversed by the current rise pulses of the drive motor of the flow pump. Using the speed of this pump, the dialysate flow can be adjusted in the dialysis program: 300, 500, and 800 ml/min. In the cleaning programs, the flow of the dialysate is fixed.

The relief valve (78) is used to limit the pressure of the flow pump before the balancing chamber to approx. 2 bar.

After the balancing chamber, the dialysate flows through the valve (30), the heat exchanger (77) and the valve (87) into the drain.

The valves (86) and (87) serve to recirculate fluid during the hot rinsing and disinfection programs.

1.3.2 Theory of operation of the balancing chamber

- (Standard program)

1st cycle:

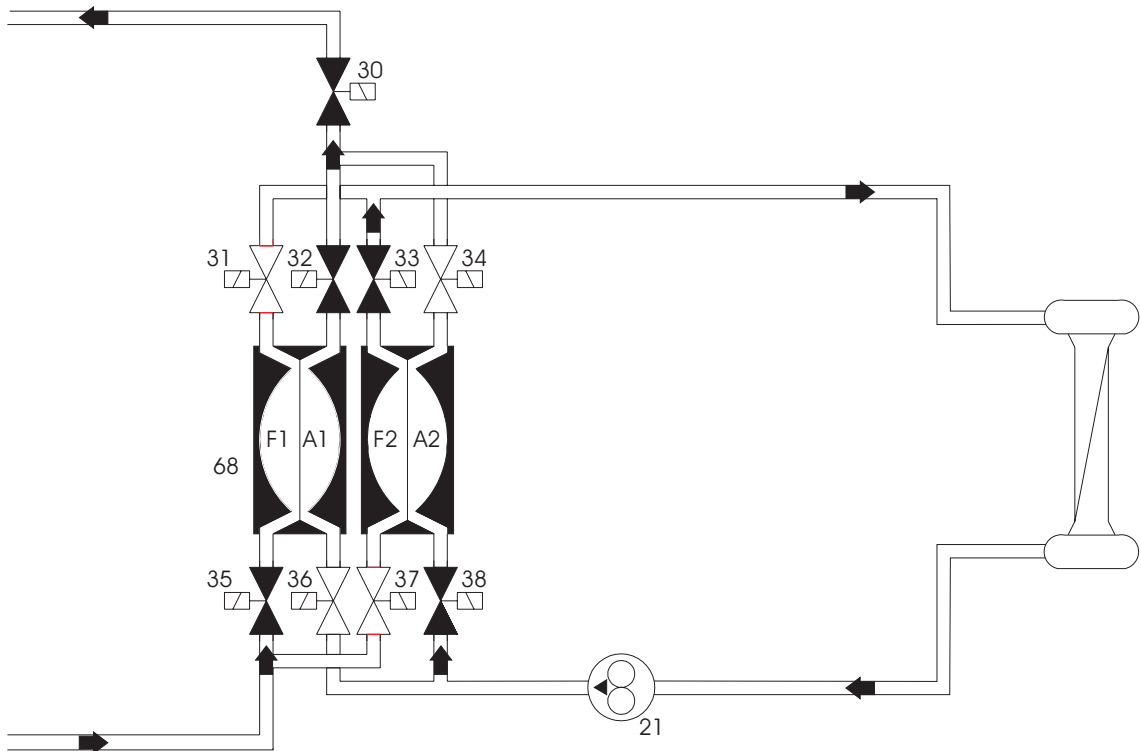

2nd cycle:

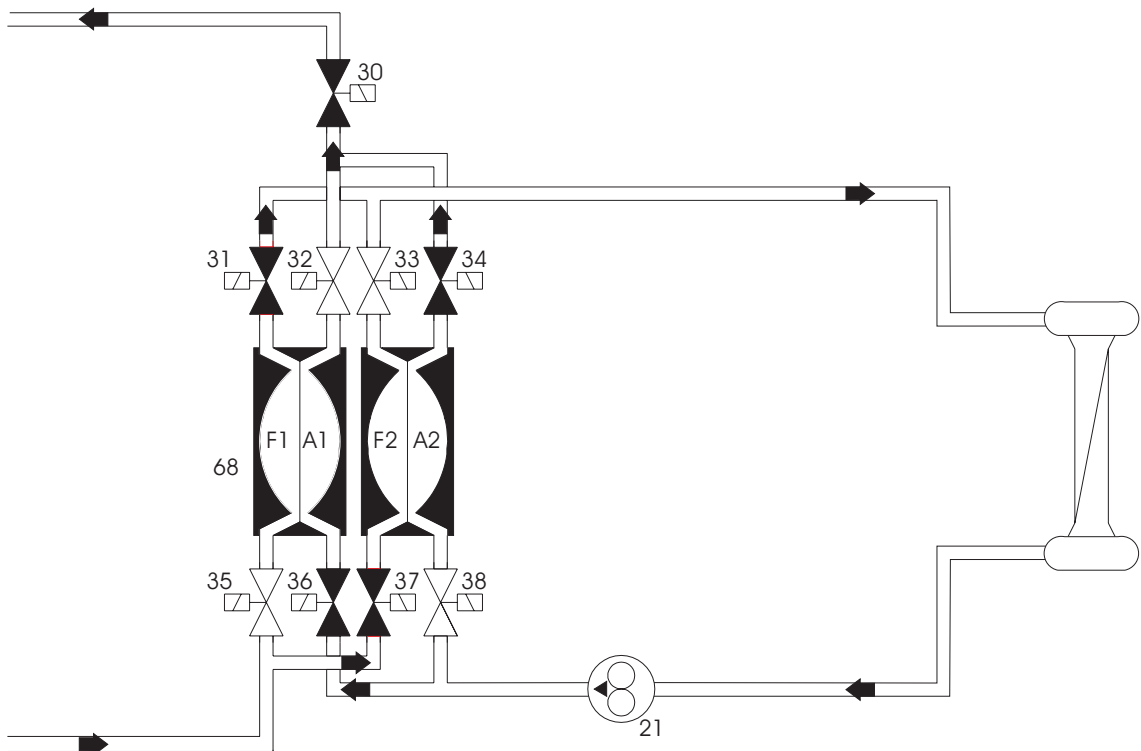

1st cycle: Closed valves: 31, 34, 36, and 37
F1 is filled with fresh dialysate.
A1 used dialysate is discharged into the drain.
F2 fresh dialysate is forced into the dialyzer.
A2 is filled with used dialysate.

2nd cycle: Closed valves: 32, 33, 35, and 38
F1 fresh solution is forced into the dialyzer.
A1 is filled with used dialysate.
F2 is filled with fresh dialysate.
A2 used dialysate is discharged into the drain.

This system ensures that equal amounts of fluid enter and exit the dialyzer. This leads to an exact balancing of the dialysate and, in conjunction with the ultrafiltration pump (22), a controlled volumetric ultrafiltration.

- **Secondary air purging by the air separation pump 97**

As soon as the fluid level in the secondary air separator (88b) has dropped below the level sensor (6), this sensor activates the air separation pump (97). Should the fluid level not have reached the level sensor (6) within a given time period, the FILL PROGRAM is started.



Note

In order to recognize the fluid level, the level sensor (6) requires fluid with a certain minimum conductivity, which is definitely achieved in all dialysis programs. Separation of air is only required in the dialysis programs. In all other programs, the air separation pump (97) and the valve (43) are force-actuated.

- **FILL PROGRAM: air separation by valve 43 at atmospheric pressure**

1st cycle:

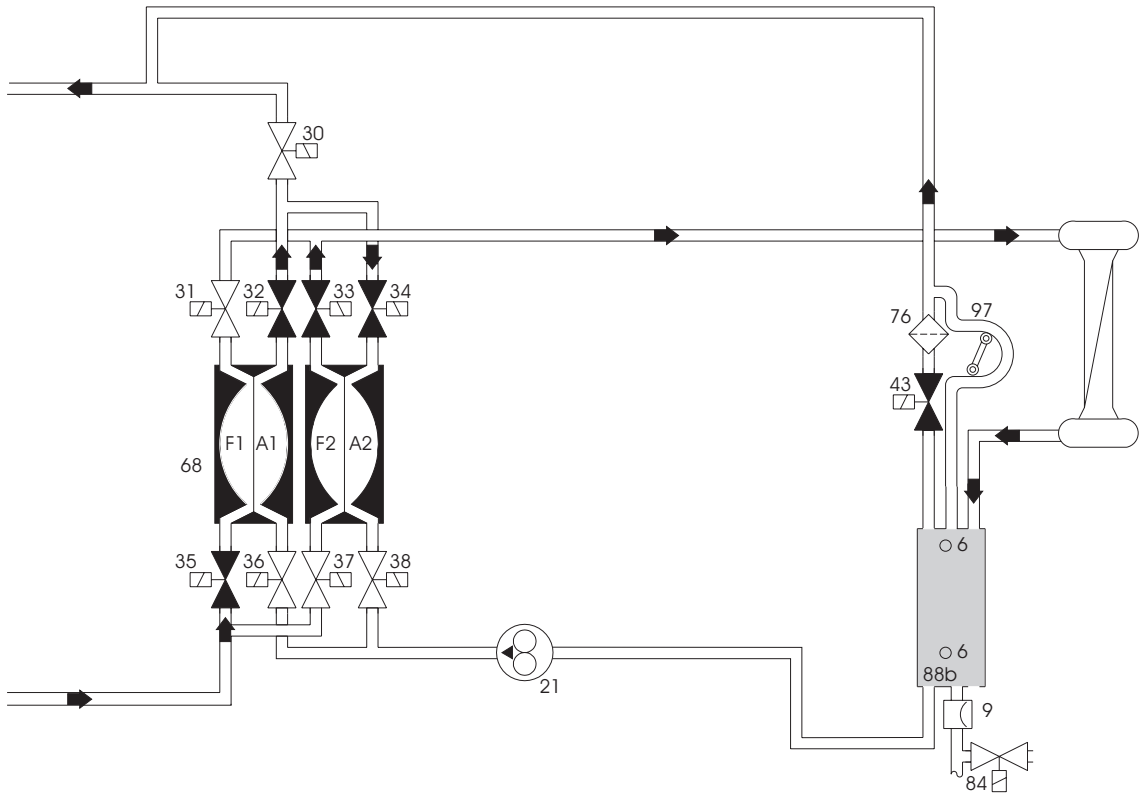

2nd cycle:

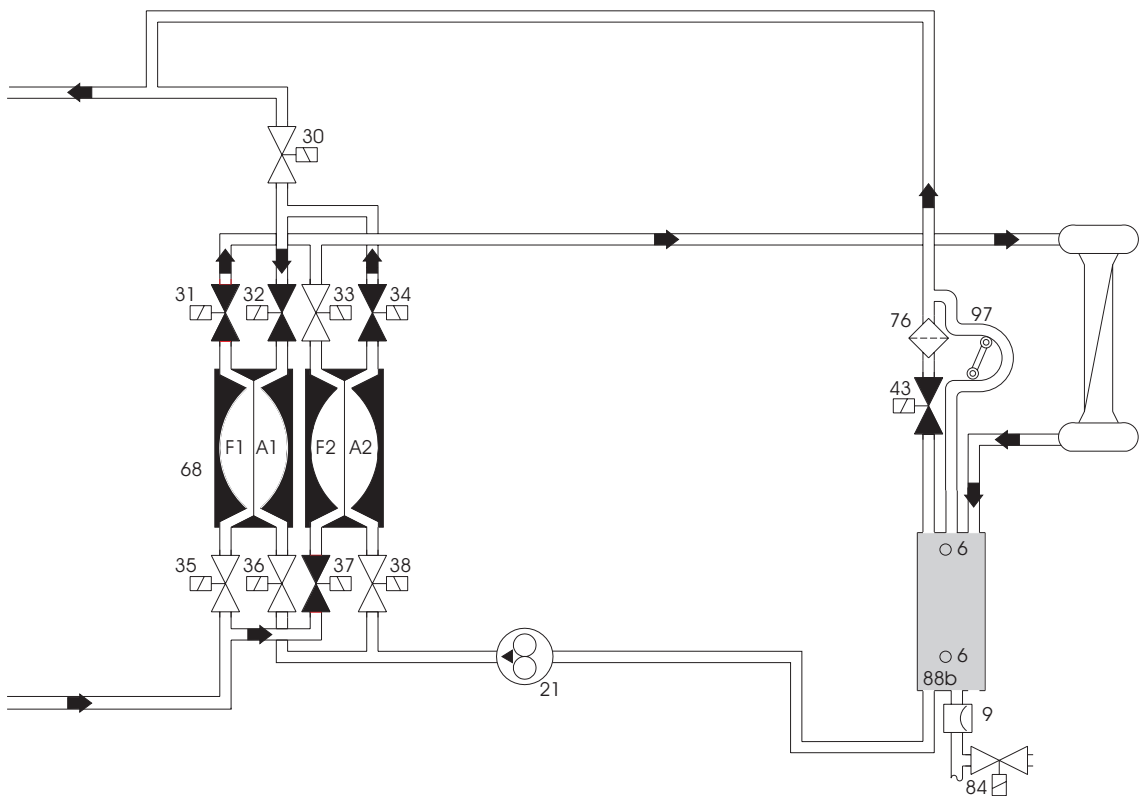

If not enough air was separated and the fluid level is still below the level sensor (6), the FILL PROGRAM is activated.

The pump (21) fills either chamber A1 or chamber A2. Valves (36), (38), and (30) are closed. The valve (43) opens. The air can escape into the drain.

1st cycle: Chamber F1 is filled. This forces the fluid from chamber A1 into chamber A2. The fluid is then forced into the secondary air separator (88b) by chamber A2 via the dialyzer.

2nd cycle: Chamber F2 is filled. This forces the fluid from chamber A2 into chamber A1. The fluid is then forced into the secondary air separator (88b) by chamber A1 via the dialyzer.

Filling is performed in this way to prevent a change in conductivity. As is the case in the standard program, here as well one stroke of the concentrate pump is still accomplished per balancing chamber cycle (30 ml).

A fill program is always activated at the beginning of hemodialysis (to fill the dialyzer). Should it be activated during the hemodialysis procedure (OD dark), this is shown on the display.



Note

Repeated activation of the fill program during treatment indicates a defect (leakages).

1.3.3 Central delivery system option

The central delivery system is connected to the connectors 121/122. The concentrate flows into the rinse chambers via the inlet filters and the valves 102/104. Through the connected concentrate suction tubes, the concentrate pumps deliver the concentrate to the mixing point.

During hemodialysis, the valves 91/99 and 100 are closed. Depending on the central delivery system, V102 and/or V104 are open.

During the cleaning programs, the valves 102 and 104 are closed. During the suction phase of concentrate pump and bicarbonate pump, the valves 91 and 99 open for 500 ms upon each balancing chamber changeover. Valve 100 is open.

In order to check the tightness of the valves 102 and 104, the pressure switch is tested during the rinse-clear phase with following disinfection or hot disinfection or a mandatory rinse. To perform this test, pressure is applied to the two lines between the check valves 117/118 and the valves 102/104. The pressure switches P123 and P124 are used to monitor the pressure. Three minutes before the mandatory rinse program is completed, a functional check of the valves 91/99 and 100 is performed.

1.3.4 Program sequences during the cleaning programs

Fig.: Flow chart of cleaning programs – overview

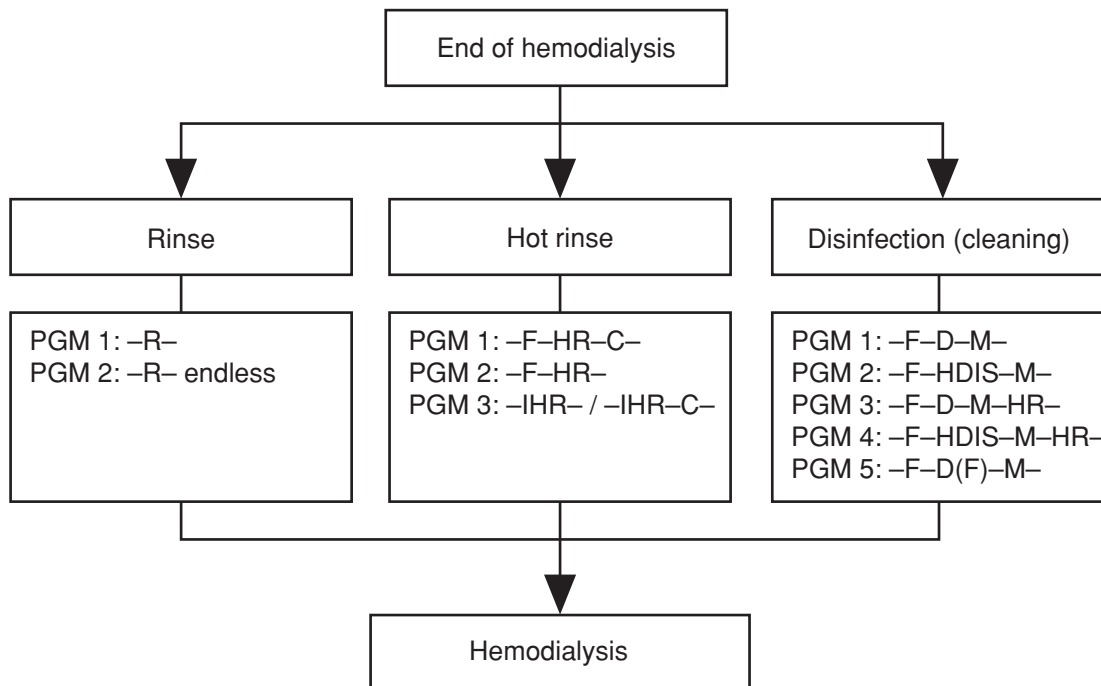

- **Explanation of the abbreviations used**

PGM	Program
R	Rinse
R endless	Endless rinse
F	Rinsing clear
HR	Hot rinsing
C	Cooling rinse
D	Disinfection
D(F)	Disinfection Disinfectant drawn in from the front (concentrate suction tube).
HDIS	Hot disinfection
M	Mandatory rinse
IHR	Integrated hot rinsing

- **Notes on program runs**

At the end of the set program, the rinse chamber is evacuated for approx. 1 min.

Any statements on time refer to the factory setting. Shorter or longer program times can be set at any time by means of the SETUP menu (see Technical Manual, chapter 6).

- Rinse

PGM 1: -R-

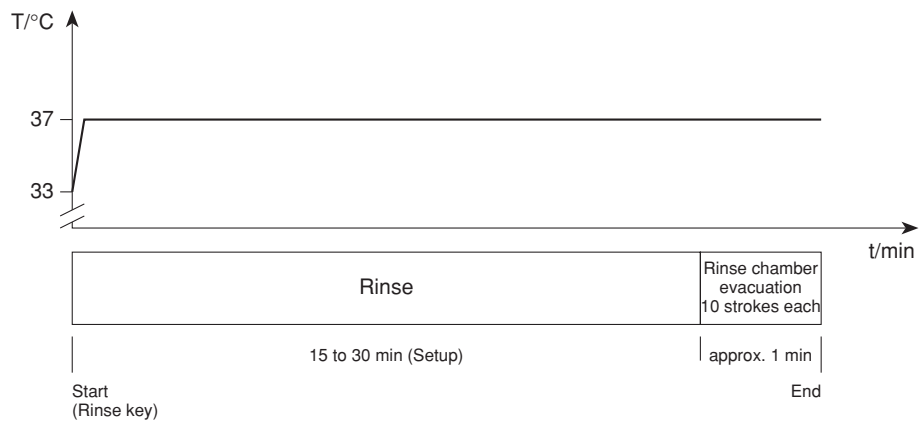

PGM 2: -R- endless

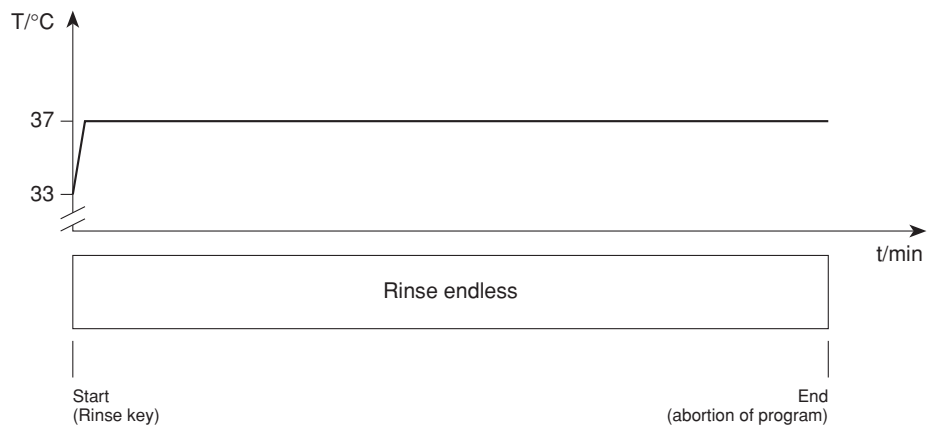

● Hot rinsing

PGM 1: -F-HR-C-

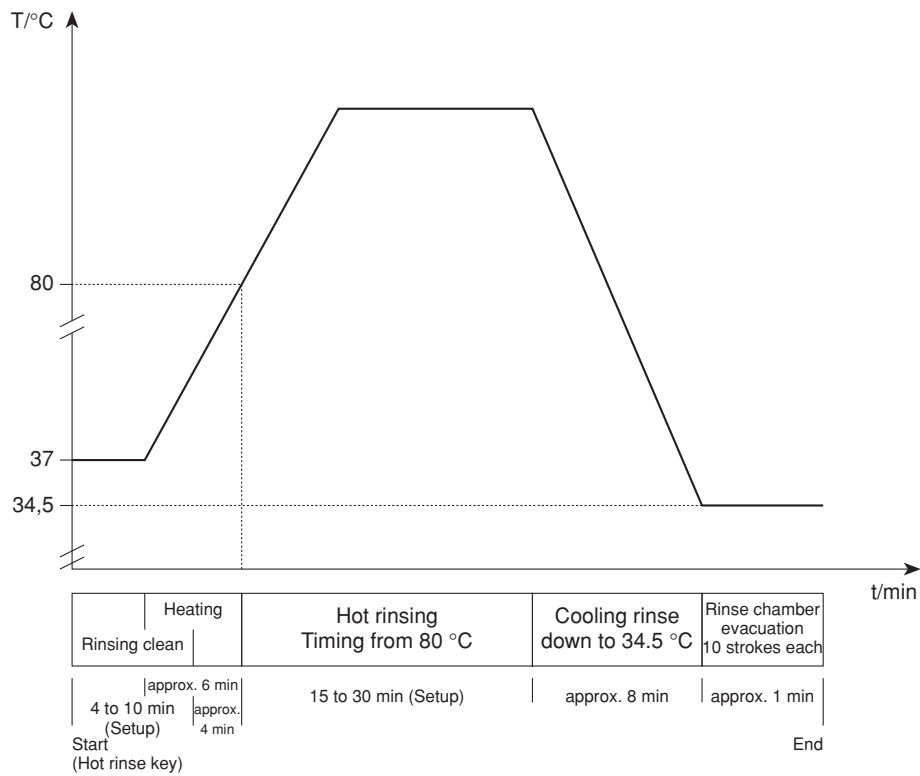

PGM 2: -F-HR-

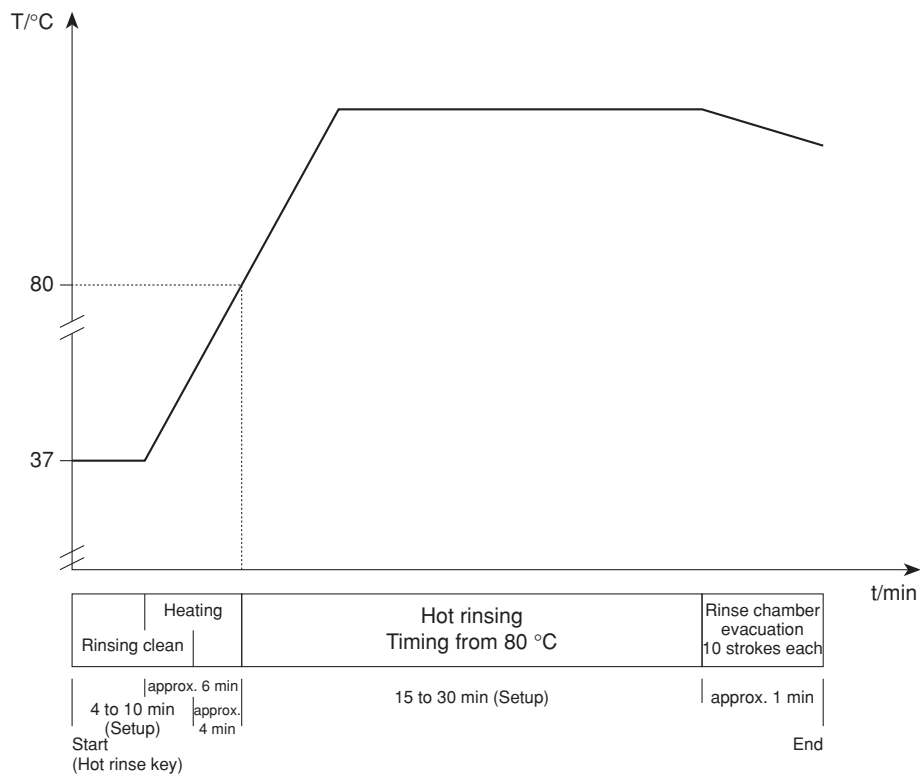

PGM 3: -IHR-

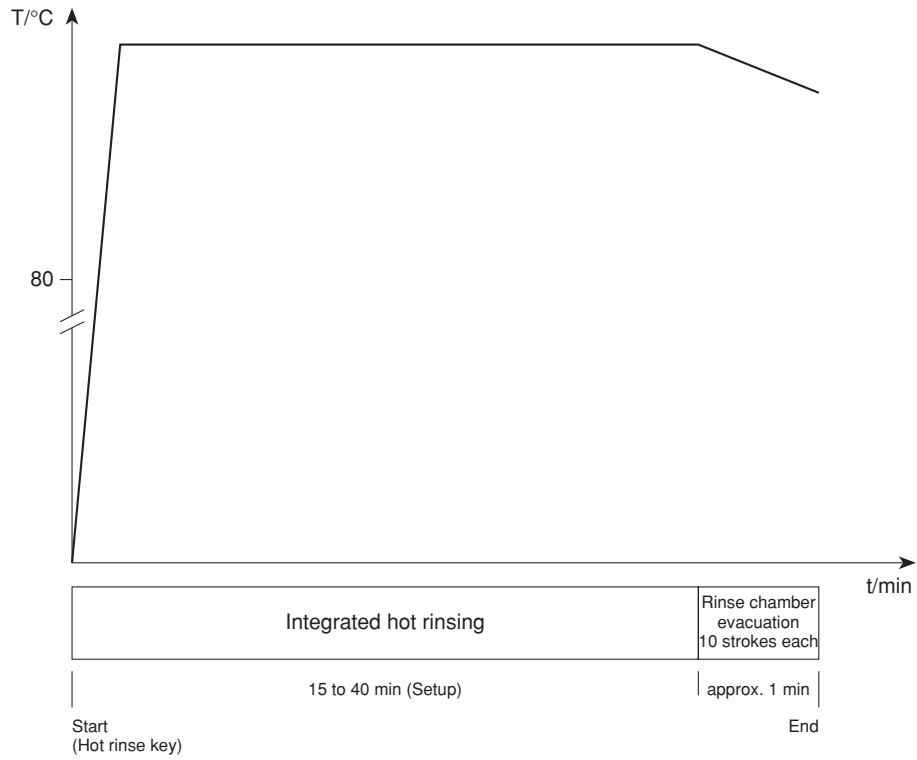

PGM 3: -IHR-C-

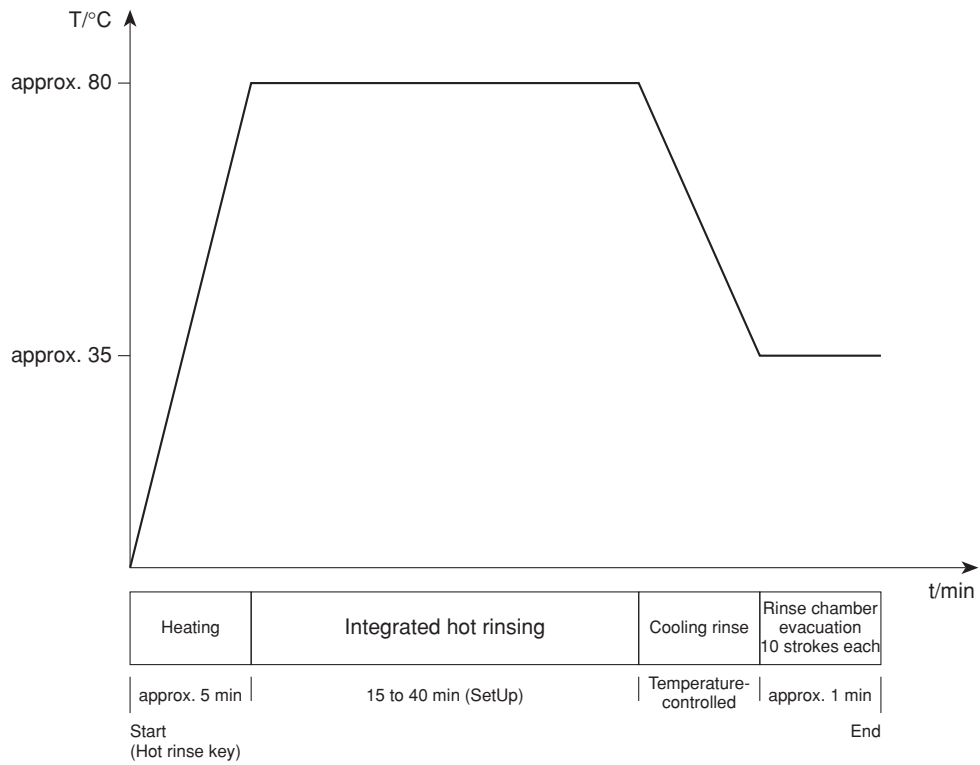

● **Disinfection**

PGM 1: -F-D-M-

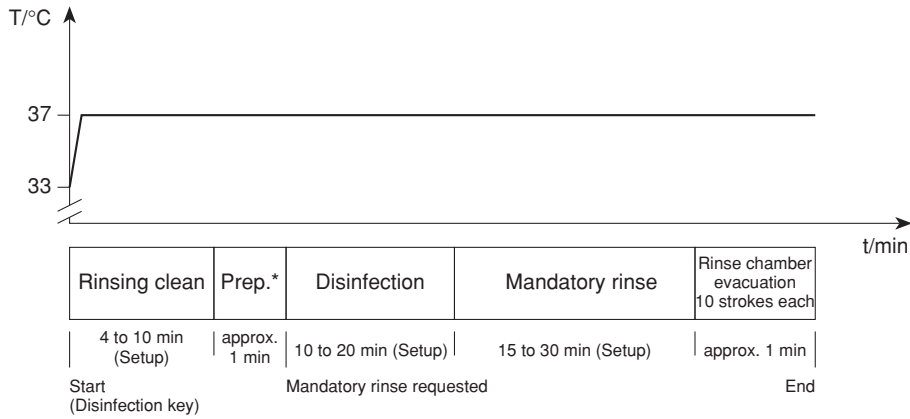

*Prep.: preparation phase:
 Heater off
 Set the level of the float switch chamber below the lower switching point of the float switch by
 1 balancing chamber changeover and
 4 UF pump strokes.
 Aspiration of disinfectant for 50 UF-pump strokes.

PGM 2: -F-HDIS-M-

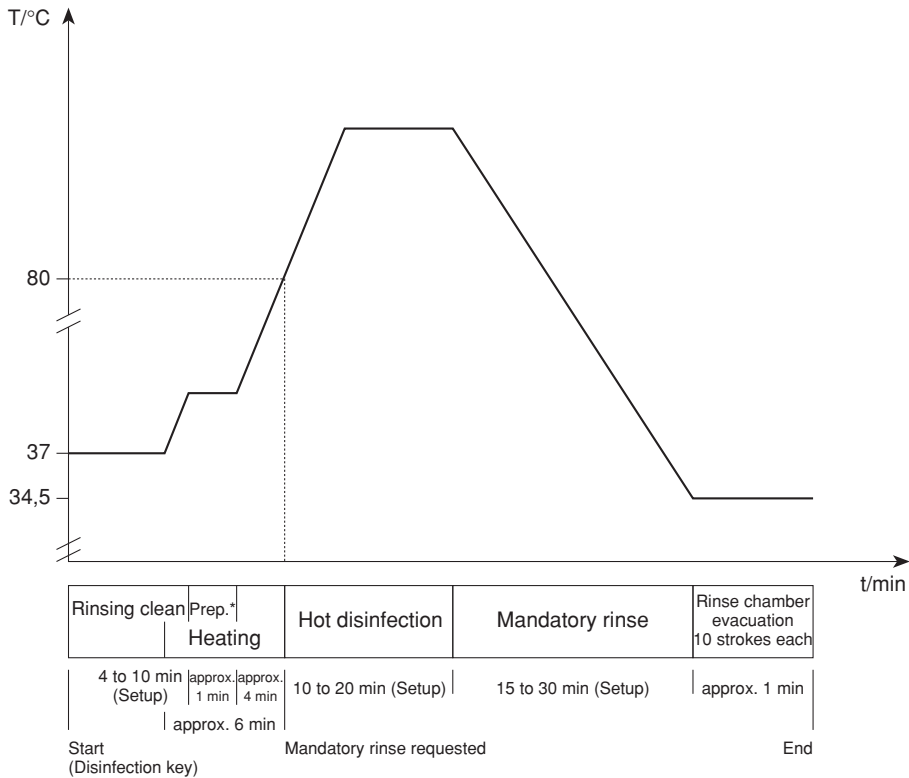

*Prep.: preparation phase:
 Heater off
 Set the level of the float switch chamber below the lower switching point of the float switch by
 1 balancing chamber changeover and
 4 UF pump strokes.
 Aspiration of disinfectant for 50 UF-pump strokes.

PGM 3: -F-D-M-HR

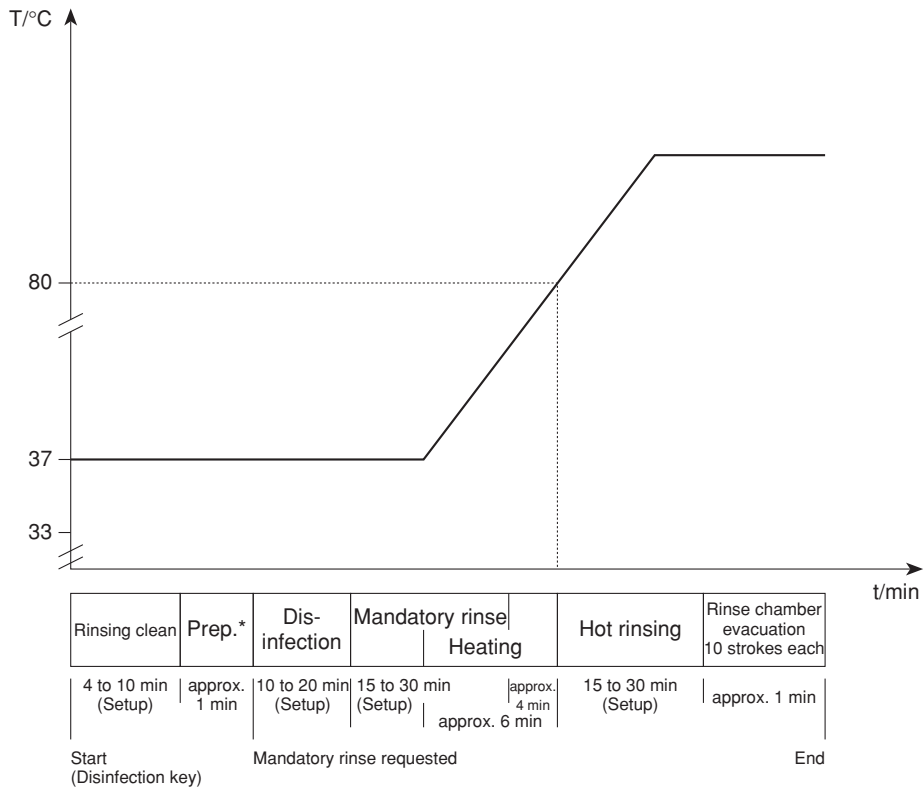

*Prep.: preparation phase:
 Heater off
 Set the level of the float switch chamber below the lower switching point of the float switch by
 1 balancing chamber changeover and
 4 UF pump strokes.
 Aspiration of disinfectant for 50 UF-pump strokes.

PGM 4: -F-HDIS-M-HR-

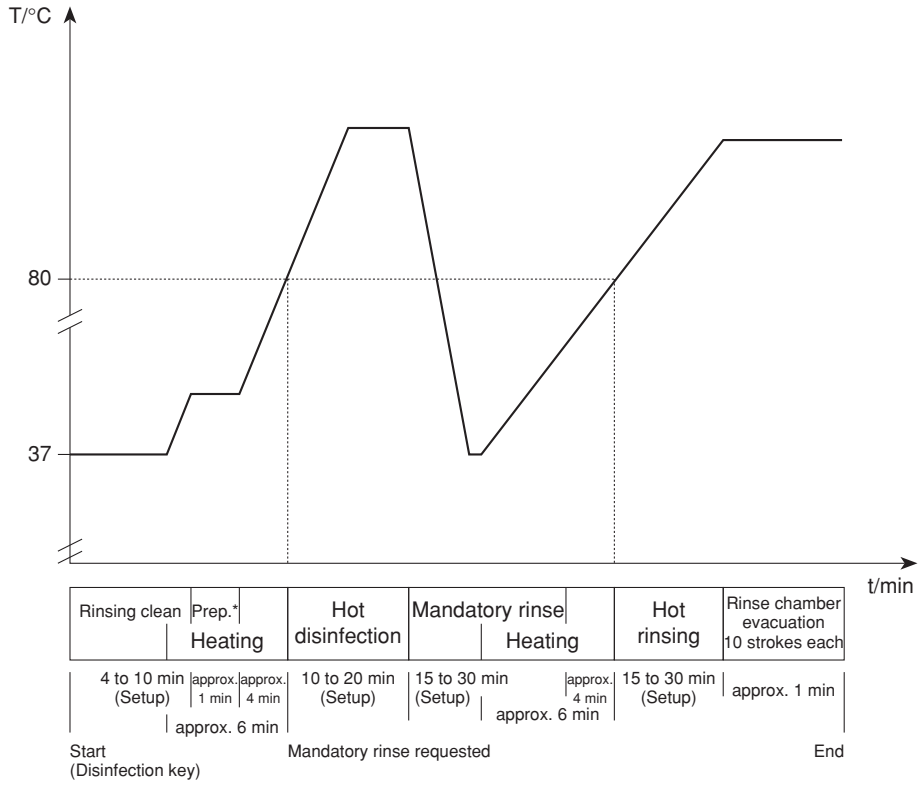

*Prep.: preparation phase:
 Heater off
 Set the level of the float switch chamber below the lower switching point of the float switch by 1 balancing chamber changeover and 4 UF pump strokes.
 Aspiration of disinfectant for 50 UF-pump strokes.

PGM 5: -F-D(F)-M-

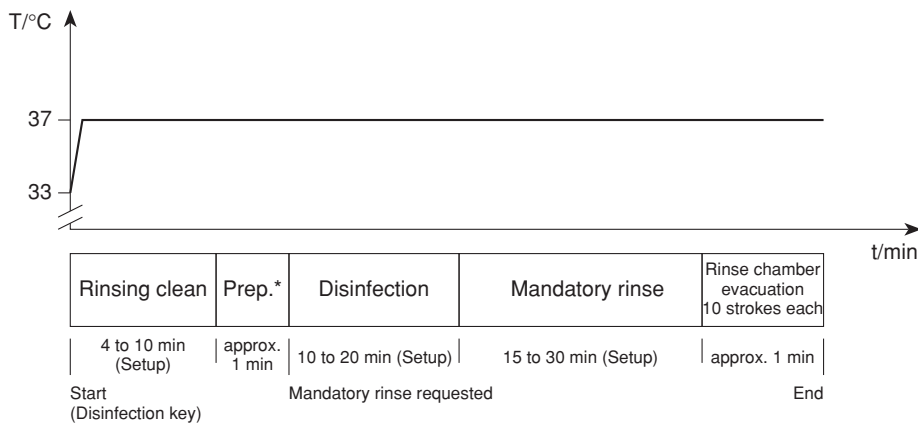

*Prep.: preparation phase:
 Heater off
 Set the level of the float switch chamber below the lower switching point of the float switch by 23 UF pump strokes.
 Aspiration of disinfectant for 32 concentrate pump strokes à 330 steps.

Table of Contents

2 Technical Safety Checks / Maintenance

Section		Page
2.1	Technical Safety Checks and Maintenance for 4008 hemodialysis systems and options	2-3
2.1.1	Important notes	2-3
2.1.2	Description – Technical Safety Checks and Maintenance	2-5
2.1.3	Report – Technical Safety Checks and Maintenance	2-16
2.1.4	Notes – Check of the electrical safety	2-21
2.2	TSC report	2-25

2.1 Technical Safety Checks and Maintenance for 4008 hemodialysis systems and options

2.1.1 Important notes

This chapter lists all necessary Technical Safety Checks (**TSC**) and Maintenance procedures (**MA**).

These checks must be performed every **24 months** if all of the following requirements have been met:

- Unique assignment of the rotors to the appropriate line roller pumps
- Software:
 - 4008 E/B systems: from 4.951 to < 5.00 or with 5.201 or higher
 - 4008 H/S systems: from 2.951 to < 3.00 or with 4.311 or higher
- DIP switch P.C.B. LP 632 array 2 SW 5 set to OFF.
- DIP switch P.C.B. LP 631 array 2 SW 7 set to ON.
- DIP switch P.C.B. LP 631 array 2 SW 8 set to ON. (With CDS option only)
- Heater rod made of Titanium

If one of the requirements mentioned above has not been met, the checks have to be performed every **12 months**.

Performance of the Technical Safety Checks must be recorded in the Medical Device Register.

Please refer to page 2-5 to page 2-14 for the description of the Technical Safety Checks and Maintenance.

Please refer to the pages 2-29 and 2-30 for the report for the Technical Safety Checks and Maintenance. Numbers not listed are not part of the TSC. These are part of the Maintenance procedures (MA).

Instructions to be observed when servicing the system

Assembly, extensions, adjustments, modifications or repairs may only be carried out by the manufacturer or persons authorized by him.

The activities described in the Technical Manual require the availability of the necessary technical test equipment and accessories.

When working on the open system, the following precautions must be respected:

- Protect the components against ingress of fluids.
- Do not touch live parts (e. g. connectors of the power cable or heater).

When repairing and when replacing spare parts, observe the applicable ESD precautions (e.g. EN 100 015-1).

2.1.2 Description – Technical Safety Checks and Maintenance

<p>These checks must be performed every 24 months if all of the following requirements have been met:</p> <ul style="list-style-type: none"> <input type="checkbox"/> Unique assignment of the rotors to the appropriate line roller pumps <input type="checkbox"/> Software: <ul style="list-style-type: none"> 4008 E/B systems: from 4.951 to < 5.00 or with 5.201 or higher 4008 H/S systems: from 2.951 to < 3.00 or with 4.311 or higher <input type="checkbox"/> DIP switch P.C.B. LP 632 array 2 SW 5 set to OFF. <input type="checkbox"/> DIP switch P.C.B. LP 631 array 2 SW 7 set to ON. <input type="checkbox"/> DIP switch P.C.B. LP 631 array 2 SW 8 set to ON. (With CDS option only) <input type="checkbox"/> Heater rod made of Titanium <p>If one of the requirements mentioned above has not been met, the checks have to be performed every 12 months.</p>	<p>Interval:</p> <ul style="list-style-type: none"> <input type="checkbox"/> 24 months <input type="checkbox"/> 12 months <p>(please check)</p>
---	--

These inspections must be carried out by persons who are qualified to properly perform the specified Technical Safety Checks owing to their educational background and training, their knowledge and experience gained in practice and who are not subject to any directions with regard to this inspection activity.

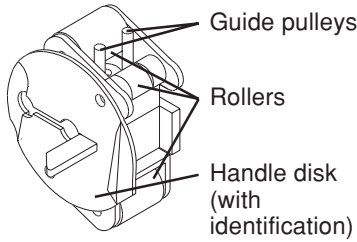
TSC	MA	No.	Description	Expected value / function
1 Visual inspections				
TSC		1.1	Fuses accessible from the outside	Must comply with the maximum permissible values.
TSC		1.2	Labels and identification	Must be present and legible.
TSC		1.3	Mechanical condition	Must permit further safe use.
TSC		1.4	Damage and contaminations	There must not be any detectable damage or contamination.
TSC		1.4.1	Rotors of the line roller pumps 	The rotors show no signs of damage. Check the rotors of the line roller pumps. <ul style="list-style-type: none"> – Rotors installed in the proper location and identification present. – Handle disks tight and undamaged. – Check the rollers for smooth running. – No mechanical damage on the guide pulleys an other parts of the rotors (see drawing) Damaged rotors must be replaced by new ones.
TSC		1.5	Power cable	Must not be damaged.

TSC	MA	No.	Description	Expected value / function
	MA	1.6	Preventive Maintenance procedures	
	MA	1.6.1	Replace the sealing in the concentrate/bicarbonate suction tubes and lubricate with silicone paste. Replace the rivet in the suction tubes, if necessary.	
	MA	1.6.2	Check the rubber in the rinse chambers for proper function.	
	MA	1.6.3	Replace the filters of the suction tubes (71/72).	
	MA	1.6.4	Retighten the rinse chamber (90a/90b) screws.	
	MA	1.6.5	Replace the check valve (92).	
	MA	1.6.6	When using CDS, replace the check valves (117/118) and the filters 119/120. Replace the filter sieves; upstream of the UF pump (filter 74), downstream of MV43 (filter 76), between MV99 and rinse chamber (filter 149), between MV100 and rinse chamber (filter 148).	
	MA	1.6.7	Replace the filter sieve in the dialyzer line; replace the complete filter (73), if necessary.	
	MA	1.6.8	Replace the O-rings in the dialyzer couplings.	
	MA	1.6.9	Check the line in the sampling valve (116) dialysate circuit for proper function, replace the complete valve, if necessary.	
	MA	1.6.10	Clean or replace the fan filter in the monitor.	
	MA	1.6.11	Check the air separation pump (97): replace the belt ribbon and the line segment. Observe direction of delivery.	
	MA	1.6.12	MV 84 must be replaced after 2 years. <i>Only if Puristeril is used.</i>	
	MA	1.6.13	Replace the connecting piece or equilibration chamber. <i>Only for systems in which the ONLINE_{plus}TM option or the DIASAFE[®]_{plus} option is not used.</i>	
	MA	1.6.14	Replace filter 210 (if present).	
	MA	1.6.15	Replace the filter of the disinfectant suction tube.	
	MA	1.6.16	Replace worn or dirty tubings.	
2 General checks				
TSC		2.1	Power failure alarm	Dialysis mode; Continuous sound after removing the power plug. Text displayed: Emergency operation The extracorporeal blood circuit incl. all monitoring functions is maintained.
TSC		2.2	Check level sensor	Draw in air via the dialysate couplings. The air separation pump is activated. If more air is detected, the system will switch to the fill program, depending on the dialysate flow. Text displayed when the OD senses opaque fluid: Fillprogram
TSC		2.3	Check DIP switches	P.C.B. LP 631 (CPU1) DIP switch array 2 SW7 is set to ON. With central delivery system: P.C.B. LP 631 (CPU1) DIP switch array 2 SW8 is set to ON.

TSC	MA	No.	Description	Expected value / function
3 Check of the hydraulics				
<i>Check all pressures with undamped pressure gauges!</i>				
	MA	3.1	Check the water inlet pressure (reduced) and correct, if necessary.	Connect a pressure gauge before MV41 to measuring point A in the hydraulic unit. With the valve MV41 closed the pressure should range between 0.9 and 1.4 bar.
	MA	3.2	Check the balancing chamber loading pressure and correct, if necessary.	Connect a pressure gauge to the pressure side of the degassing pump (measuring point B in the hydraulic unit). The pressure should be between 1.2 and 1.3 bar. In case of the equipment codes 4008B - EC495 4008H - EC295 4008S - EC275 and higher, the pressure must be 1.45 bar \pm 0.05 bar.
	MA	3.3	Check the negative degassing pump pressure	Connect a pressure gauge to the suction side of the degassing pump (measuring point D in the hydraulic unit). The negative pressure should be between 0.81 and 0.85 bar.
	MA	3.4	Check the balancing chamber relief pressure at a flow of 800 ml/min (relief valve 78).	Connect a pressure gauge to the pressure side of the flow pump (measuring point C in the hydraulic unit). The relief pressure depends on the loading pressure set (\rightarrow MA 3.2): Loading pressure: Relief pressure: 1.2 to 1.3 bar 1.9 to 2.1 bar 1.45 \pm 0.05 bar 2.2 \pm 0.05 bar
4 Ultrafiltration system and membrane pumps				
STK		4.1	Check the delivery volume of the UF pump.	In the dialysis mode collect 60 ml of dialysate in an appropriate graduated cylinder. 60 strokes = 60 ml (\pm 0.5 ml). Correct the setting of the UF pump, if necessary.
	WA	4.2	Check the balancing chamber volume.	Collect the volume of two consecutive balancing chamber switchings. The average volume must be 30 ml \pm 1 ml.
	WA	4.3	Test the concentrate pump volume or compare it with an appropriate reference.	Adjust according to calibration instructions, if necessary.
	WA	4.4	Test the bicarbonate pump volume or compare it with an appropriate reference.	Adjust according to calibration instructions, if necessary.

TSC	MA	No.	Description	Expected value / function
5 Dialysis mode				
	MA	5.1	Temperature	Use a reference meter connected between the dialyzer couplings to verify that the temperature is 37 °C ±0.5 °C. Correct any deviations with the calibration program.
	MA	5.2	Temperature display (not applicable for 4008 B / 4008 S)	The temperature shown on the monitor front panel must be 37 °C ±0.5 °C. Correct any deviations with the calibration program.
	MA	5.3	Verify the dialysate flow 300/500/800 ml/min	Collect fluid on the drain using a measuring cylinder. 800 ml/min (desired value: 765 to 837 ml/min) 500 ml/min (desired value: 471 to 528 ml/min) 300 ml/min (desired value: 279 to 321 ml/min) Adjust according to calibration instructions, if necessary.
	MA	5.4	Dialysate pressure	Perform a TMP test according to the calibration instructions. (part 14 CAL. DIAL. PRESSURE)
TSC		5.5	Verify the conductivity display	When the <i>bi/bag</i> [®] option is used, connect a <i>bi/bag</i> [®] ! Measure the conductivity with a reference meter connected between the dialyzer couplings. The conductivity measured must agree with the value on the reference meter. Correct any deviations with the calibration program.

TSC	MA	No.	Description	Expected value / function
6 Extracorporeal components				
	MA	6.1	Arterial pressure transducer	Check the slope of the pressure transducer. After applying a pressure of approx. 200 mmHg to the pressure transducer the value displayed must agree with the reading shown on the external reference meter (tolerance ± 10 mmHg). Correct any deviations with the calibration program.
	MA	6.2	Venous pressure transducer	Check the slope of the pressure transducer. After applying a pressure of approx. 300 mmHg to the pressure transducer the value displayed on the system must agree with the reading shown on the external reference meter (tolerance ± 10 mmHg). Correct any deviations with the calibration program.
TSC		6.3	Arterial and Single-Needle blood pump rate	Check the blood pump rate (calibration program: BP-Rate CHECK).
TSC		6.4	SN switching points	Check the switching points according to the table in the TM.
TSC		6.5	Check the blood pump stop alarm.	Opening the blood pump door will trigger the blood pump stop alarm after 30 s (factory setting).
TSC		6.6	Air detector	In the event of a blood alarm, the venous line clamp must close. Generate a pressure of about 2 bar in the venous bubble catcher. Ensure that the pressure does not drop by more than 0.1 bar within 3 minutes. (See chapter 3, Adjustment instructions.)
TSC		6.7		

TSC	MA	No.	Description	Expected value / function
7 Options				
7.1 <i>bi/bag</i> [®]				
	MA	7.1.1	<i>bi/bag</i> [®] connector	Replace the O-rings.
	MA	7.1.2	PSW 134	Check the switching pressure. The maximum switching pressure is 130 mbar + 30 mbar.
7.2 DIASAFE				
	MA	7.2.1	DIASAFE filter life	Check the filter life. Filter life: 12 weeks
	MA	7.2.2	Hydrophobic filter 111	Replace the filter.
	MA	7.2.3	O-rings in the dialysate couplings of the DIASAFE	Replace the O-rings.
7.3 <i>DIASAFE^{®plus}</i>				
	MA	7.3.1	<i>DIASAFE^{®plus}</i> filter life	Check the filter life. Filter life: 12 weeks
	MA	7.3.2	Hydrophobic filter 111	Replace the filter.
7.4 4008 HDF				
TSC		7.4.1	Check the delivery rate of the 2 nd UF pump.	Collect 60 ml of dialysate in the dialysis mode using an appropriate measuring cylinder. 60 strokes = 60 ml (±0.5 ml) If necessary, correct the value.

TSC	MA	No.	Description	Expected value / function
7.5 ON-LINE-HDF (and DIASAFE)				
	MA	7.5.1	Filter life of DIASAFE and ON-LINE filter	Check the filter life. Filter life of the DIASAFE: 12 weeks Filter life of ON-LINE filter: 8 weeks or 50 treatments
	MA	7.5.2	Hydrophobic filter 111	Replace the filter.
	MA	7.5.3	O-rings in the dialysate couplings of the DIASAFE	Replace the O-rings.
	MA	7.5.4	HDF pump rotor	Check the rotor for smooth running and wear.
	MA	7.5.5	Fastening strap	Check the fastening strap for Luer-lock.
TSC		7.5.6	Substitute pump (part no. 672 521 1) with DC motor <i>or</i> Substitute pump (part no. 674 982 1) with stepper motor	Speed 150 ml/min To determine the delivery volume: the volume of fluid delivered must agree with the preset value ($\pm 10\%$). To check the speed: with the above setting the blood pump rotor must turn at 13.5 rpm. (See Technical Manual ON-LINE-HDF, chapter 3). Check the pump rate (calibration program: BP-Rate CHECK).
TSC		7.5.7	Substitute pump stop	Stop the substitute pump by – triggering a blood alarm, – triggering the bypass function, – opening the blood pump door.
TSC		7.5.8	Substitute pump function – Rinse – Hot rinse – Disinfection	Start the rinse program; the pump will deliver at 400 ml/min. Start the hot rinse program; the pump will deliver at 150 ml/min. Start the disinfection program; the pump will deliver at 400 ml/min.

TSC	MA	No.	Description	Expected value / function
7.6 ONLINE _{plus} TM (and DIASAFE ^{®plus})				
	MA	7.6.1	Filter life of DIASAFE ^{®plus} and ONLINE _{plus} TM filter	Check the filter life. Filter life of DIASAFE ^{®plus} and ONLINE _{plus} TM filter: 12 weeks or 100 treatments
	MA	7.6.2	Hydrophobic filters 111 and 184	Replace the filters.
	MA	7.6.3	Substitute port (195) and rinse port (194)	Replace the O-rings.
TSC		7.6.4	Line pinch valve 193 (ONL1)	Replace the line.
TSC		7.6.5	Check DIP switch	With HPU (hydraulic processing unit) P.C.B. LP 632 (CPU2) DIP switch array 2 switch 5 is set to OFF.
7.7 OCM				
	MA		Perform OCM PULSE calibration.	

TSC	MA	No.	Description	Expected value / function
7.8 BPM 4008				
	MA	7.8.1	Labels and indications	Must be present and clearly legible. Check of the actual condition.
	MA	7.8.2	Mechanical condition	Must permit further safe use.
	MA MA MA	7.8.2.1 7.8.2.2 7.8.2.3	Check whether the line connector is correctly attached to the system. Check whether the internal blood pressure module, the printed circuit boards and all cable connections are correctly fixed. Replace damaged lines or cuffs.	
	MA	7.8.2.4	Indicating elements	Visual and audible functional checks after turn-on. (See Operating Instructions BPM 4008, chapter 2.2)
	MA	7.8.2.5	Touch panel	Check whether the touch panel is functioning correctly.
TSC		7.8.3	Leakage test	Perform the leakage test with cuff and pressure line connected. The pressure leakage rate must be less than 6 mmHg/min. (See Technical Manual BPM 4008, chapter 3.1)
TSC		7.8.4	Calibration	Calibration: Pressure values: Tolerance: 250 mmHg ±5 mmHg 200 mmHg ±4 mmHg 150 mmHg ±3 mmHg 100 mmHg ±3 mmHg 50 mmHg ±3 mmHg (See Technical Manual BPM 4008, chapter 3.2)
TSC		7.8.5	Safety valve	Check the safety valve. The system must be discharged at 320 mmHg ± 10 mmHg. (See Technical Manual BPM 4008, chapter 3.3)
TSC		7.8.6	Measuring of blood pressure	Measure the blood pressure in the manual mode. Check the results for plausibility.
7.9 BTM 4008				
			No further Technical Safety Checks and Maintenance procedures must be performed.	
7.10 BVM 4008				
			No further Technical Safety Checks and Maintenance procedures must be performed.	

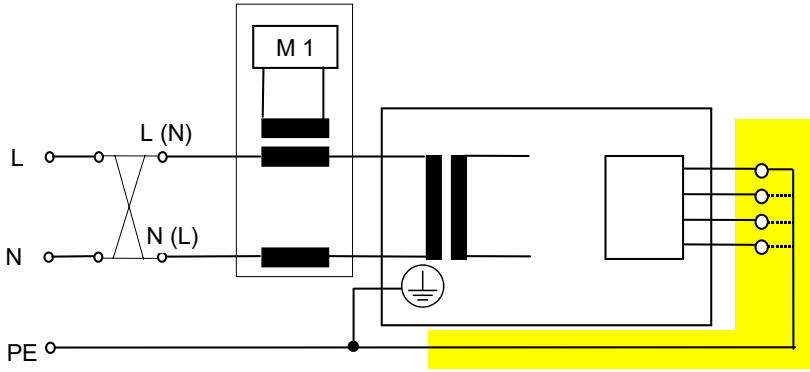
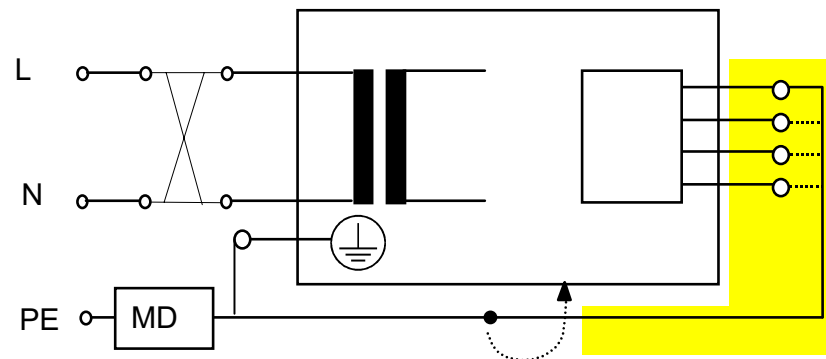
TSC	MA	No.	Description	Expected value / function
<p>8 Check of the electrical safety In Germany according to DIN VDE 0751 standard – 1st edition 10/2001. In other countries, observe the local regulations!</p>				
<p>For measuring points, see 2.1.4 Notes – Check of the electrical safety.</p>				
TSC		8.1	Visual inspections performed	see item 1 Visual inspections
TSC		8.2	Protective earth resistance	Max. 0.3 Ω (with power cable)
TSC		8.3	Measurement of the leakage current (device leakage current) Differential current measurement according to fig. C.6  <p><i>or</i></p> Direct measurement according to fig. C.5 	
<p>Basic conditions:</p> <ul style="list-style-type: none"> – Measurement of the protective earth resistance has been completed. – Perform the measurement with the system being at operating temperature in the Dialysis or Preparation operation mode. – Dialysate: Dialysis temperature $\geq 37^{\circ}\text{C}$ Dialysate flow ≥ 300 ml/min Conductivity ≥ 13 mS/cm – When performing a direct measurement, the following precautions must be observed: The system must be installed under insulated conditions. All external connections must have been removed from the system. 				

TSC	MA	No.	Description	Expected value / function
			<p>Documentation covers the line voltage during the measurement and the maximum device leakage current of both mains polarities scaled to the line voltage of the power supply. Maximum device leakage current: 500 µA</p> <p>Example: Line voltage during measurement: 225 V Device leakage current for mains polarity 1: 180 µA for mains polarity 2: 120 µA Maximum value of both mains polarities: 180 µA Nominal voltage of the power supply: 230 V Scaled to nominal voltage: 184 µA (180 µA : 225 V • 230 V = 184 µA) Device leakage current < 500 µA: OK</p> <p>Additional conditions: If the device leakage current is higher than 90 % of the admissible alarm limit (450 µA), the last measured value or the first measured value must additionally be considered for the rating. If the device leakage current considerably increased since the last measurement or continuously increased since the first measurement (creeping deterioration of the insulation), or if the sum composed of the current value plus the difference since the last measurement is > 500 µA, the measurement has not been passed.</p> <p>Example 1: Leakage current: 470 µA Last measured value: 450 µA $470 + (470 - 450) = 470 + 20 = 490 \rightarrow \text{OK}$</p> <p>Example 2: Leakage current: 470 µA Last measured value: 390 µA $470 + (470 - 390) = 470 + 80 = 550 \rightarrow \text{not passed}$</p>	
9 Functional check				
TSC		9.1	Perform the functional test	Press the Test key. The system must successfully pass the T1 test.
	MA	9.2	Hot rinse / disinfection	Run a disinfection program.

2.1.3 Report – Technical Safety Checks and Maintenance

<p>These checks must be performed every 24 months if all of the following requirements have been met:</p> <ul style="list-style-type: none"> <input type="checkbox"/> Unique assignment of the rotors to the appropriate line roller pumps <input type="checkbox"/> Software: <ul style="list-style-type: none"> 4008 E/B systems: from 4.951 to < 5.00 or with 5.201 or higher 4008 H/S systems: from 2.951 to < 3.00 or with 4.311 or higher <input type="checkbox"/> DIP switch P.C.B. LP 632 array 2 SW 5 set to OFF. <input type="checkbox"/> DIP switch P.C.B. LP 631 array 2 SW 7 set to ON. <input type="checkbox"/> DIP switch P.C.B. LP 631 array 2 SW 8 set to ON. (With CDS option only) <input type="checkbox"/> Heater rod made of Titanium <p>If one of the requirements mentioned above has not been met, the checks have to be performed every 12 months.</p>	<p>Interval:</p> <ul style="list-style-type: none"> <input type="checkbox"/> 24 months <input type="checkbox"/> 12 months <p>(please check)</p>
---	--

Customer/Customer no.:		Service report no.:
Serial no.:	Inventory no.:	Operating hours:
System type: 4008 <input type="checkbox"/> 4008 B <input type="checkbox"/> 4008 H <input type="checkbox"/> 4008 S <input type="checkbox"/>		
With option: SN <input type="checkbox"/> bi bag ® <input type="checkbox"/> 4008 HDF <input type="checkbox"/> ON-LINE-HDF <input type="checkbox"/> ONLINE ^{plus} ™ <input type="checkbox"/> BTM <input type="checkbox"/> BPM <input type="checkbox"/> BVM <input type="checkbox"/> DIASAFE <input type="checkbox"/> DIASAFE ^{plus} <input type="checkbox"/> OCM <input type="checkbox"/>		

1 Visual checks

- TSC 1.1 Fuses accessible from the outside comply with the indicated values.....
- TSC 1.2 Labels and identifications present and legible
- TSC 1.3 Mechanical conditions permits further safe use
- TSC 1.4 No damage or contaminations detectable
- TSC 1.4.1 The rotors of the line roller pumps show no signs of damage
- TSC 1.5 Power cable not damaged
- 1.6 Preventive Maintenance procedures
- MA 1.6.1 Sealing in the suction tubes changed and lubricated, rivet replaced
- MA 1.6.2 Rubber in rinse chambers checked for proper function
- MA 1.6.3 Suction tube filters replaced
- MA 1.6.4 Rinse chamber screws tight
- MA 1.6.5 Check valve replaced
- MA 1.6.6 Pre-UF pump filter, filter downstream of MV43, filter between rinse chambers, and on MV99, MV100, CDS and disinfectant port replaced
- MA 1.6.7 Dialysate filter replaced or sieve changed
- MA 1.6.8 O-rings in dialyzer couplings replaced
- MA 1.6.9 Sampling valve functions properly
- MA 1.6.10 Fan filter replaced
- MA 1.6.11 Ribbon belt and line segment in air separation pump changed
- MA 1.6.12 MV84, replaced after 2 years. (Only if Puristeril is used.)
- MA 1.6.13 Connecting piece or equilibration chamber replaced. (Only if ONLINE^{plus}™ or DIASAFE^{plus} option is not used.)
- MA 1.6.14 Filter 210 replaced (if present)
- MA 1.6.15 Filter of the disinfectant suction tube replaced
- MA 1.6.16 No dirty or worn tubings

	2	General checks	
TSC	2.1	Power failure alarm – continuous sound – display: Emergency operation	<input type="checkbox"/>
TSC	2.2	Air separation by air separation pump activated; display if more air must be separated and OD senses opaque fluid: fill program	<input type="checkbox"/>
TSC	2.3	Check DIP switches P.C.B. LP 631 (CPU1) DIP switch array 2 SW7 is set to ON. With central delivery system: P.C.B. LP 631 (CPU1) DIP switch array 2 SW8 is set to ON.	<input type="checkbox"/>
	3	Check of the hydraulics	
MA	3.1	Water inlet pressure (reduced) 0.9 bar to 1.4 bar	<i>Measured value:</i> _____ <input type="checkbox"/>
MA	3.2	Loading pressure 1.25 bar ±0.05 bar	<i>Measured value:</i> _____ <input type="checkbox"/>
		With EC495 (4008B); EC295(4008H), EC 275 (4008S) and higher Loading pressure 1.45 bar ±0.05 bar	<i>Measured value:</i> _____ <input type="checkbox"/>
MA	3.3	Negative degassing pump pressure 0.81 to 0.85 bar	<i>Measured value:</i> _____ <input type="checkbox"/>
MA	3.4	Balancing chamber relief pressure at 800 ml/min	<i>Measured value:</i> _____ <input type="checkbox"/>
		Loading pressure: Relief pressure: 1.2 to 1.3 bar 1.9 to 2.1 bar 1.45 ± 0.05 bar 2.2 ± 0.05 bar	
	4	Ultrafiltration system and membrane pumps	
TSC	4.1	UF pump, 1 stroke = 1 ml, 60 strokes = 60 ml ±0.5 ml	<i>Measured value:</i> _____ <input type="checkbox"/>
MA	4.2	Average balancing chamber volume 30 ± 1 ml	<i>Measured value:</i> _____ <input type="checkbox"/>
MA	4.3	Concentrate pump calibration volume removal / number of strokes	<i>Measured value:</i> _____ <input type="checkbox"/>
MA	4.4	Bicarbonate pump calibration volume removal / number of strokes	<i>Measured value:</i> _____ <input type="checkbox"/>
	5	Dialysis mode	
MA	5.1	Expected temperature 37 °C ± 0.5 °C	<i>Measured value:</i> _____ <input type="checkbox"/>
MA	5.2	Temperature display 37 °C ± 0.5 °C	<i>Measured value:</i> _____ <input type="checkbox"/>
MA	5.3	Dialysate flow check 800 ml/min (desired value: 765 to 837 ml/min)	<i>Measured value:</i> _____ <input type="checkbox"/>
		500 ml/min (desired value: 471 to 528 ml/min)	<i>Measured value:</i> _____ <input type="checkbox"/>
		300 ml/min (desired value: 279 to 321 ml/min)	<i>Measured value:</i> _____ <input type="checkbox"/>
MA	5.4	Dialysate pressure – Check zero point with flow off	<input type="checkbox"/>
		– Slope checked	<input type="checkbox"/>
TSC	5.5	Conductivity display checked with reference meter	<input type="checkbox"/>
		If the bi bag ® option is used, connect a bi bag ®! – CD system	<i>Measured value:</i> _____ <input type="checkbox"/>
		– CD ref.	<i>Measured value:</i> _____ <input type="checkbox"/>
	6	Extracorporeal components	
MA	6.1	Arterial pressure displayed checked with reference meter	<input type="checkbox"/>
MA	6.2	Venous pressure displayed checked with reference meter	<input type="checkbox"/>
TSC	6.3	Blood pumps: blood pump rate checked (calibration program: BP-Rate CHECK)	<input type="checkbox"/>
TSC	6.4	SN switching pressure checked according to table in TM	<input type="checkbox"/>
TSC	6.5	Blood pump stop alarm checked	<input type="checkbox"/>
TSC	6.6	Venous line clamp closes after blood alarm	<input type="checkbox"/>
TSC	6.7	Pressure of about 2 bar in the venous bubble catcher	<input type="checkbox"/>
		Pressure must not drop by more than 0.1 bar within 3 minutes.	<input type="checkbox"/>

7 Options

- 7.1 *bi.bag*[®]
- MA 7.1.1 *bi.bag*[®] connector, O-rings replaced
- MA 7.1.2 Switching pressure of PSW134 checked,
130 mbar, + 30 mbar *Measured value:* _____
- 7.2 DIASAFE
- MA 7.2.1 DIASAFE filter life checked
- MA 7.2.2 Hydrophobic filter 111 replaced
- MA 7.2.3 O-rings in the dialysate couplings of the DIASAFE replaced
- 7.3 DIASAFE^{®plus}
- MA 7.3.1 DIASAFE^{®plus} filter life checked
- MA 7.3.2 Hydrophobic filter 111 replaced
- 7.4 4008 HDF
- TSC 7.4.1 2nd UF pump 1 stroke = 1 ml, 60 strokes = 60 ml ± 0.5 ml *Measured value:* _____
- 7.5 ON-LINE-HDF (and DIASAFE)
- MA 7.5.1 Filter life of the DIASAFE and ON-LINE filter checked
- MA 7.5.2 Hydrophobic filter 111 replaced
- MA 7.5.3 O-rings in the dialysate couplings of the DIASAFE replaced
- MA 7.5.4 HDF pump rotor checked (smooth running, wear)
- MA 7.5.5 Fastening strap for Luer-lock checked
- TSC 7.5.6 Substitute pump
- (part no. 672 521 1) with DC motor:
volume delivered by the pump checked *desired/actual:* ____/____
- or**
- (part no. 674 982 1) with stepper motor:
pump rate checked (calibration program: HDF-P.-Rate CHECK)
- TSC 7.5.7 Substitute pump stop
– after blood alarm
- after triggering the bypass function
- after opening the blood pump door
- TSC 7.5.8 Check substitute pump for proper function
– Rinse program, delivery rate: 400 ml/min
- Hot rinse program, delivery rate: 150 ml/min
- Disinfection program, delivery rate: 400 ml/min
- 7.6 ONLINE^{plus}[™] (and DIASAFE^{®plus})
- MA 7.6.1 Filter life of DIASAFE^{®plus} and ONLINE^{plus}[™] checked
- MA 7.6.2 Hydrophobic filters 111 and 184 replaced
- MA 7.6.3 O-rings in substitute port 195 and in rinse port 194 replaced
- TSC 7.6.4 Line in the line pinch valve 193 (ONL1) replaced
- TSC 7.6.5 Check DIP switch
With HPU (hydraulic processing unit)
P.C.B. LP 632 (CPU2) DIP switch array 2 switch 5 is set to OFF.
- 7.7 OCM
- MA OCM PULSE calibration performed

- 7.8 BPM 4008
- MA 7.8.1 Labels and indications are present and legible
- MA 7.8.2 Mechanical condition permits further safe use
- MA 7.8.2.1 Line connector is correctly fixed to the system
- MA 7.8.2.2 Internal blood pressure module, printed circuit boards, cable connections are correctly fixed
- MA 7.8.2.3 Damaged lines or cuffs have been replaced
- MA 7.8.2.4 Indicating elements checked
- MA 7.8.2.5 Touch panel checked
- TSC 7.8.3 Leakage test: pressure leakage rate less than 6 mmHg/min
- TSC 7.8.4 Calibration:

Pressure values	Tolerance	
250 mmHg	±5mmHg <i>Measured value:</i> _____ <input type="checkbox"/>
200 mmHg	±5mmHg <i>Measured value:</i> _____ <input type="checkbox"/>
150 mmHg	±3mmHg <i>Measured value:</i> _____ <input type="checkbox"/>
100 mmHg	±3mmHg <i>Measured value:</i> _____ <input type="checkbox"/>
50 mmHg	±3mmHg <i>Measured value:</i> _____ <input type="checkbox"/>
- TSC 7.8.5 Safety valve: discharge at 320 mmHg, ±10 mmHg
- TSC 7.8.6 Blood pressure measured

7.9 BTM 4008
No further Technical Safety Checks and Maintenance procedures must be performed.

7.10 BVM 4008
No further Technical Safety Checks and Maintenance procedures must be performed.

8 Check of the electrical safety

In Germany according to DIN VDE 0751 standard – 1st Edition 10/2001.

In other countries, observe the local regulations!

For measuring points, see 2.1.4 VDE check.

For 4008 HDF option, check additional measuring point!

- TSC 8.1 Visual inspections performed according to item 1
- TSC 8.2 Protective earth resistance max. 0.3 Ω (with power cable) *Measured value:* _____
- TSC 8.3 Measurement of the leakage current
 - Differential current measurement according to fig. C.6
 - or**
 - Direct measurement according to fig. C.5

Nominal voltage of power supply	_____	<i>Volt</i>
Device leakage current mains polarity 1	_____	<i>µA</i>
for line voltage	_____	<i>Volt</i>
scaled to nominal voltage (maximum 500 µA, see also Additional conditions)	_____	<i>Measured value:</i> _____
Device leakage current mains polarity 2	_____	<i>µA</i>
for line voltage	_____	<i>Volt</i>
scaled to nominal voltage (maximum 500 µA, see also Additional conditions)	_____	<i>Measured value:</i> _____

Test equipment used: _____

9 Final checks

- TSC 9.1 T1 test performed
- MA 9.2 Hot rinse / disinfection performed

Date:	Signature:	Stamp:
--------------	-------------------	---------------

The system has been released for further use <input type="checkbox"/> Yes <input type="checkbox"/> No
--

Remarks:

Date:	Signature:	Stamp:
--------------	-------------------	---------------

2.1.4 Notes – Check of the electrical safety

- Test 4008 E, 4008 H

1. Protective earth resistance measuring points

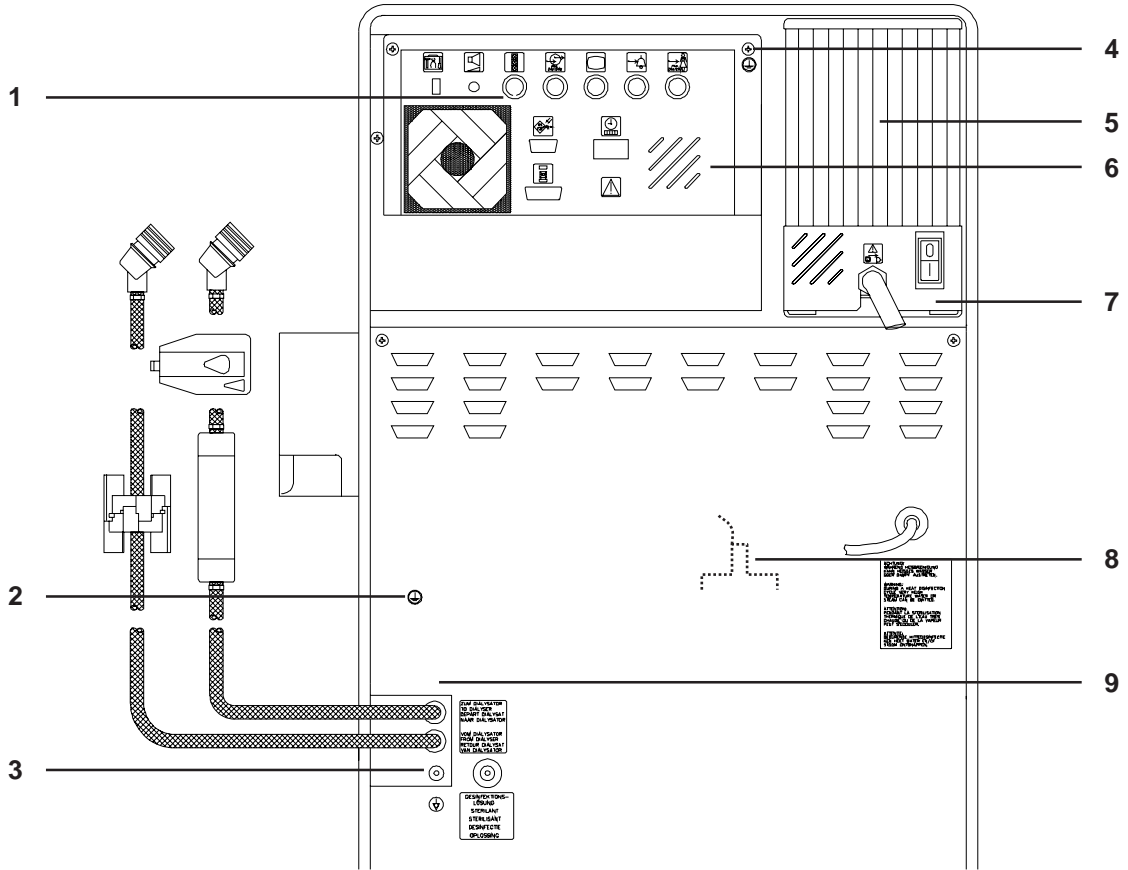

Legend

- | | | | |
|---|---|---|--|
| 1 | Monitor rear panel (ports housing) | 4 | Upper rear panel (screw) |
| 2 | Hydraulic unit rear panel (plate on the push-on blade inside) | 5 | Heat sink (power supply unit) |
| | Caution: The grounding cable must be connected. | 6 | Monitor rear panel (plate) |
| 3 | Ground stud for potential equalization | 7 | Power supply plate |
| | | 8 | Heater rod housing (hydraulic unit open) |
| | | 9 | Dialyzer line ports (hydraulic unit open / earthing screw) |

2. Use a meter (e.g. SECUTEST 0701) to check the leakage current.

- Test 4008 B, 4008 S

1. Protective earth resistance measuring points

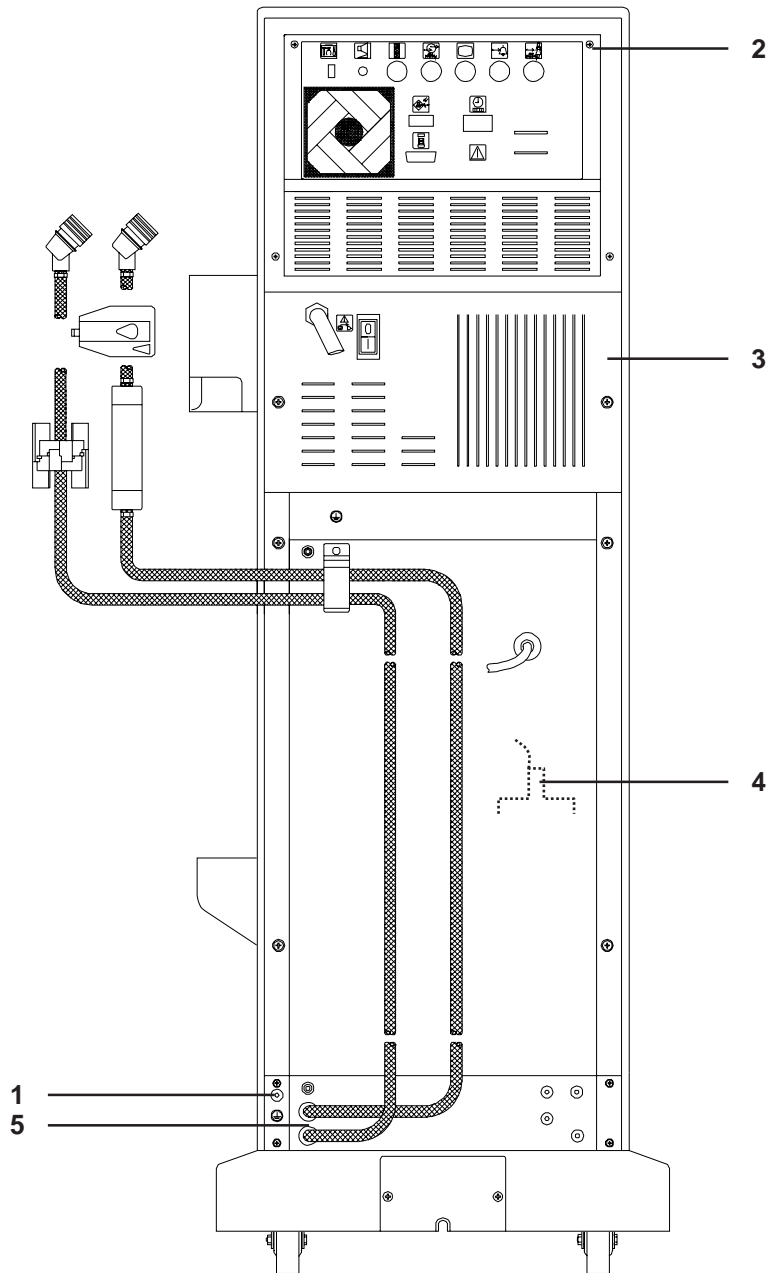

Legend

- | | | | |
|---|--|---|--|
| 1 | Ground stud for potential equalization | 3 | Heat sink (power supply unit) |
| 2 | Upper rear panel (screw) | 4 | Heater rod housing (hydraulic unit open) |
| 5 | Dialyzer line ports (adapters) | | |

2. Use a meter (e.g. SECUTEST 0701) to check the leakage current.

- **Test 4008 HDF (option)**

- 1. Protective earth resistance measuring point**

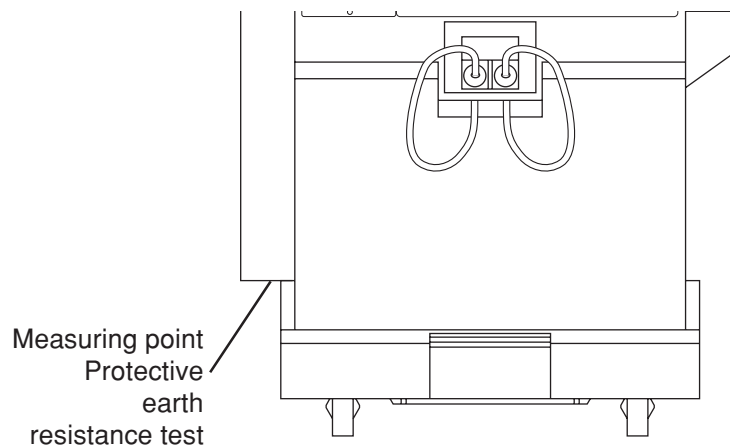

- 2. Use a meter (e.g. SECUTEST 0701) to check the leakage current.**

- 3. Measurement conditions**

The measurements must be taken in the dialysis mode in the “ON phase” of the heater control system.

The scales must be moved out to such an extent that neither of the two end switches are actuated (middle position).

2.2 TSC report

4008	TSC report Page 1/2	 Fresenius Medical Care
-------------	--------------------------------	---

<p>These checks must be performed every 24 months if all of the following requirements have been met:</p> <ul style="list-style-type: none"> <input type="checkbox"/> Unique assignment of the rotors to the appropriate line roller pumps <input type="checkbox"/> Software: <ul style="list-style-type: none"> 4008 E/B systems: from 4.951 to < 5.00 or with 5.201 or higher 4008 H/S systems: from 2.951 to < 3.00 or with 4.311 or higher <input type="checkbox"/> DIP switch P.C.B. LP 632 array 2 SW 5 set to OFF. <input type="checkbox"/> DIP switch P.C.B. LP 631 array 2 SW 7 set to ON. <input type="checkbox"/> DIP switch P.C.B. LP 631 array 2 SW 8 set to ON. (With CDS option only) <input type="checkbox"/> Heater rod made of Titanium <p>If one of the requirements mentioned above has not been met, the checks have to be performed every 12 months.</p>	<p>Interval:</p> <p><input type="checkbox"/> 24 months <input type="checkbox"/> 12 months</p> <p>(please check)</p>
---	---

Name of technician:		Service report no.:	
Customer/Customer no.:			
Inventory no.:	Serial no.:	Operating hours:	
System type: With option(s):			

No.	Description	Measured value	✓
1	Visual inspections		
1.1	Fuses accessible from the outside comply with the indicated values	-	<input type="checkbox"/>
1.2	Labels and identifications are present and legible	-	<input type="checkbox"/>
1.3	Mechanical condition permits further safe use	-	<input type="checkbox"/>
1.4	No damage or contaminations detectable	-	<input type="checkbox"/>
1.4.1	No signs of damage on the line roller pump rotors	-	<input type="checkbox"/>
1.5	Power cable not damaged	-	<input type="checkbox"/>
2	General checks		
2.1	Power failure alarm – continuous sound – text displayed: Emergency operation	-	<input type="checkbox"/>
2.2	Air separation by air separation pump activated; text displayed if more air must be separated and OD senses opaque fluid: Fill program	-	<input type="checkbox"/>
2.3	Check of DP switches P.C.B. LP 631 (CPU1) DIP switch array 2 SW7 is set to ON. With Central Delivery System: P.C.B. LP 631 (CPU1) DIP switch array 2 SW8 is set to ON.	-	<input type="checkbox"/>
4	Ultrafiltration system and membrane pumps		
4.1	UF pump, 1 stroke = 1 ml, 60 strokes = 60 ml ± 0.5 ml	<input type="checkbox"/>
5	Dialysis mode		
5.5	Conductivity display checked using a reference meter (If the <i>bi/bag</i> ® option is used, connect a <i>bi/bag</i> ®.)	CD system/CD ref. /	<input type="checkbox"/>
6	Extracorporeal components		
6.3	Blood pumps: check the blood pump rate (calibration program: BP-Rate CHECK)	-	<input type="checkbox"/>
6.4	SN switching pressure checked according to table in TM	-	<input type="checkbox"/>
6.5	Blood pump stop alarm checked	-	<input type="checkbox"/>
6.6	Venous line clamp closes after blood alarm	-	<input type="checkbox"/>
6.7	Pressure of approx. 2 bar in the venous bubble catcher. Pressure must not drop by more than 0.1 bar within 3 minutes.	-	<input type="checkbox"/>
7	Options		
7.4	4008 HDF		
7.4.1	Volume delivered by the 2 nd UF pump checked: 60 strokes = 60 ml ± 0.5 ml	<input type="checkbox"/>
7.5	Online-HDF		
7.5.6	<input type="checkbox"/> Substitute pump (part no. 672 521 1) with DC motor: check volume delivered by the pump <div style="text-align: right; margin-right: 20px;">desired/actual</div> /		<input type="checkbox"/>
	or <input type="checkbox"/> Substitute pump (part no. 674 982 1) with stepper motor: check the pump rate (calibration program:BP-Rate CHECK)	-	<input type="checkbox"/>

Nr.	Bezeichnung	Meßwert	✓
7.5.7	Substitute pump stop: – after blood alarm – after triggering the bypass function – after opening the blood pump door	– – –	<input type="checkbox"/> <input type="checkbox"/> <input type="checkbox"/>
7.5.8	Check substitute pump for proper function: – Rinse program, delivery rate: 400 ml/min – Hot rinse program, delivery rate: 150 ml/min – Disinfection program, delivery rate: 400 ml/min	– – –	<input type="checkbox"/> <input type="checkbox"/> <input type="checkbox"/>
7.6	ONLINE ^{plus} ™		
7.6.4	Line in the line pinch valve 193 (ONL1) replaced	–	<input type="checkbox"/>
7.6.5	Check of DP switch With HPU (hydraulic processing unit) P.C.B. LP 632 (CPU2) DIP switch array 2 SW5 is set to OFF.	–	<input type="checkbox"/>
7.8	BPM 4008		
7.8.3	Leakage test: pressure leakage rate less than 6 mmHg/min	<input type="checkbox"/>
7.8.4	Calibration 250 mmHg ± 5 mmHg 200 mmHg ± 5 mmHg 150 mmHg ± 3 mmHg 100 mmHg ± 3 mmHg 50 mmHg ± 3 mmHg	<input type="checkbox"/> <input type="checkbox"/> <input type="checkbox"/> <input type="checkbox"/> <input type="checkbox"/>
7.8.5	Safety valve: discharge at 320 mmHg ± 10 mmHg	<input type="checkbox"/>
7.8.6	Blood pressure measured	–	<input type="checkbox"/>
8	Checking the electrical safety In Germany according to DIN VDE 0751 standard –1 st edition 10/2001. In other countries, observe the local regulations!		
8.1	Visual inspection performed according to item 1.		<input type="checkbox"/>
8.2	Protective earth resistance maximum 0.3 ohms (with power cable) Ω	<input type="checkbox"/>
8.3	Measurement of the leakage current (device leakage current) <input type="checkbox"/> Differential current measurement according to fig. C.6 or <input type="checkbox"/> Direct measurement according to fig. C.5 Nominal voltage of power supply: V Device leakage current mains polarity 1 µA for line voltage V scaled to nominal voltage (maximum 500 µA, see also Additional conditions) µA Device leakage current mains polarity 2 µA for line voltage V scaled to nominal voltage (maximum 500 µA, see also Additional conditions) µA Test equipment used		<input type="checkbox"/>
9	Functional test		
9.1	T1 test performed	–	<input type="checkbox"/>

Date:	Signature:	Stamp:
-------	------------	--------

The system has been released for further use	<input type="checkbox"/> Yes <input type="checkbox"/> No
--	--

Remarks:

Date:	Signature:	Stamp:
-------	------------	--------

Table of contents

3 Adjustment instructions

Section	Page
Fig.: Measuring equipment	3-2
Fig.: Flow diagram hydraulics incl. DIASAFE ^{®plus} (Option) with basic hydraulics	3-4
Fig.: Flow diagram hydraulics 4008 with advanced hydraulics	3-6
Fig.: P.C.B. overview	3-8
3.1 Overview of the DIP switches in the 4008	3-9
3.1.1 P.C.B. LP 631 (CPU 1) DIP switch array 1	3-9
3.1.2 P.C.B. LP 631 (CPU 1) DIP switch array 2	3-10
3.1.3 P.C.B. LP 632 (CPU 2) DIP switch array 1	3-11
3.1.4 P.C.B. LP 632 (CPU 2) DIP switch array 2	3-12
3.2 Calibration mode	3-13
3.2.1 Basic conditions	3-13
3.2.2 Messages on the displays on the UF monitor (4008 E/B) or on the screen (4008 H/S)	3-13
3.3 Hydraulics	3-15
3.3.1 Reduced water inlet pressure	3-16
3.3.2 Degassing pump pressure	3-18
3.3.3 Balancing chamber loading pressure	3-20
3.3.4 Flow pump pressure	3-22
3.3.5 UF pump volume	3-24
3.3.6 CDS pressure switch	3-26
3.3.7 bi [®] bag [®] pressure transducer calibration	3-28
3.4 Air detector	3-31

Fig.: Measuring equipment



Pos.	Measuring equipment
1	Pressure gauge HMED with carrying case (set)
2	Universal measuring device UMED (set) (conductivity, pressure, temperature)
3	Secutest VDE tester (without printer module) Printer module (not ill.) Carrying case (not ill.)
4	Calibration kit for 22 mm AD
5	4008 Service Software set
6	Electronic pocket scales Test weight with spirit level and certificate
7	Measuring cylinder, 100 ml (not ill.)
8	Special tool for installation and removal of modules (not ill.)
9	ESD service kit
10	ESD work station kit
11	IC extraction tool

The current list of the measuring equipment with part numbers can be found in the electronic Spare Parts Catalog.

Fig.: Flow diagram hydraulics incl. DIASAFE[®]plus (Option) with basic hydraulics

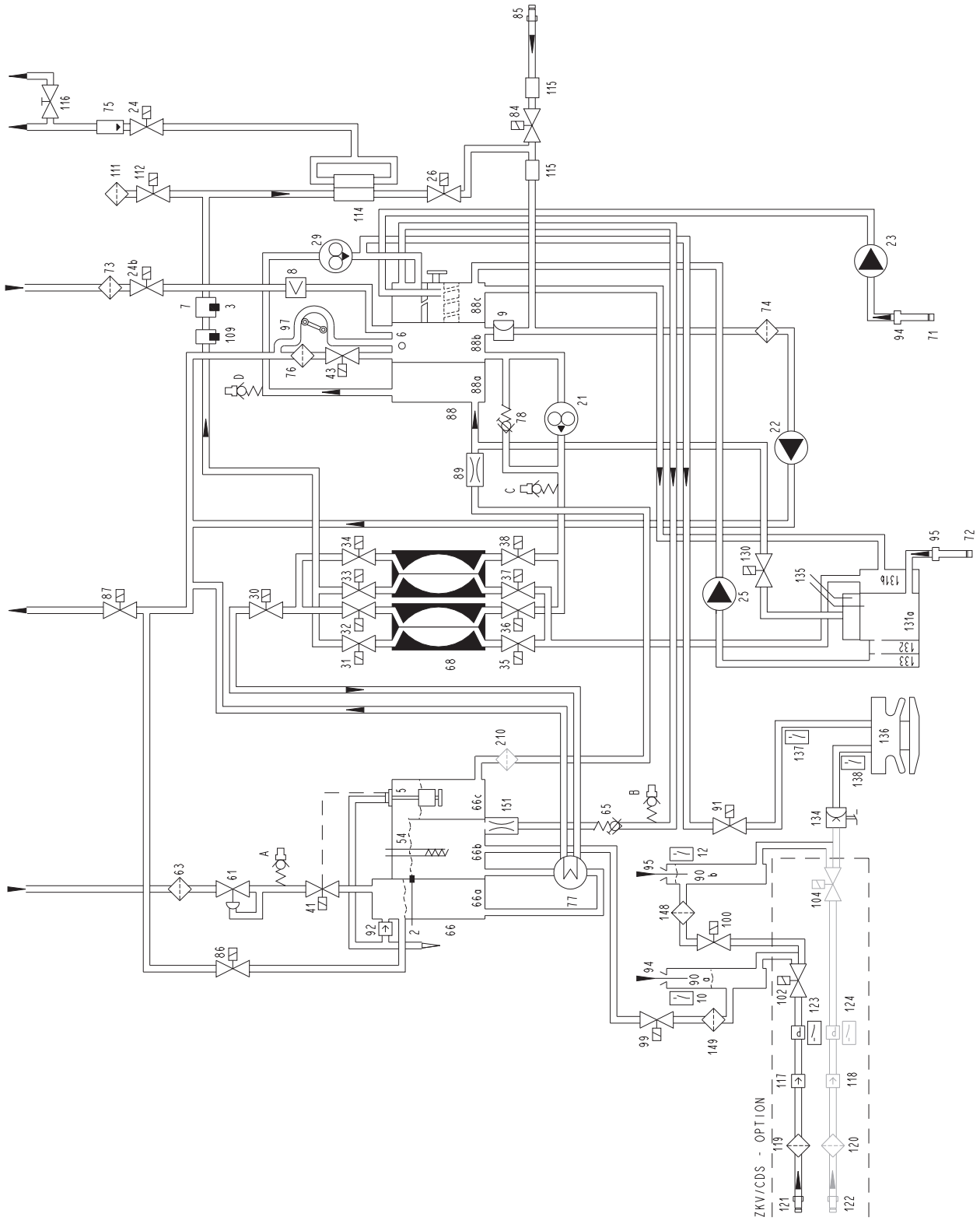

Legend

2	Temperature sensor	86	Recirculation valve
3	Temperature sensor	87	Drain valve
5	Float switch	88	Multifunction block
6	Level sensor	88a	Degassing chamber
7	Conductivity cell	88b	Secondary air separator
8	Blood leak detector	88c	Primary air separator
9	Pressure transducer	89	Degassing orifice
10	Reed contact for concentrate	90a	Rinse chamber concentrate
12	Reed contact for bicarbonate	90b	Rinse chamber bicarbonate
21	Flow pump	91	Rinse valve
22	UF pump	92	Vent valve
23	Concentrate pump	94	Concentrate suction tube
24	Dialyzer valve 1	95	Bicarbonate suction tube
24b	Dialyzer valve 2	97	Air separation pump
25	Bicarbonate pump	99	Rinse valve
26	Bypass valve	100	Rinse valve
29	Degassing pump	102	Central concentrate delivery valve
30	Outlet valve	104	Central bicarbonate delivery valve
31	Balancing chamber valve 1	109	Temperature sensor
32	Balancing chamber valve 2	111	Hydrophobic filter
33	Balancing chamber valve 3	112	Vent valve
34	Balancing chamber valve 4	114	Dialysate filter
35	Balancing chamber valve 5	115	Sensor disinfection valve
36	Balancing chamber valve 6	116	Sampling valve
37	Balancing chamber valve 7	117	Check valve (concentrate)
38	Balancing chamber valve 8	118	Check valve (bicarbonate)
41	Water inlet valve	119	Filter (concentrate)
43	Fill valve	120	Filter (bicarbonate)
54	Heater rod	121	Central concentrate delivery connector
61	Pressure reducing valve	122	Central bicarbonate delivery connector
63	Water inlet filter	123	Pressure switch for V102
65	Loading pressure valve	124	Pressure switch for V104
66	Heater block	130	bi bag [®] drain valve
66a	Water inflow chamber	131	bi bag [®] block
66b	Heater rod chamber	131a	bi bag [®] air sep. chamber
66c	Float chamber	131b	bi bag [®] mixing chamber
68	Balancing chamber	132	bi bag [®] conductivity cell
71	Filter/concentrate	133	bi bag [®] temperature sensor
72	Filter/bicarbonate	134	bi bag [®] pressure transducer
73	Filter/dialysate ext.	135	bi bag [®] level sensor
74	Filter/UF	136	bi bag [®] connector
75	External flow indicator	137	bi bag [®] microswitch 1
76	Filter/fill valve	138	bi bag [®] microswitch 2
77	Heat exchanger	148	Filter/rinse valve 100
78	Relief valve	149	Filter/rinse valve 99
84	Disinfectant valve	151	Orifice
85	Disinfectant connector	210	Filter (degassing orifice)

Hydraulics measuring points

- A Reduced water inlet pressure
- B Balancing chamber loading pressure
- C Flow pump pressure
- D Degassing pump pressure

Fig.: Flow diagram hydraulics 4008 with advanced hydraulics

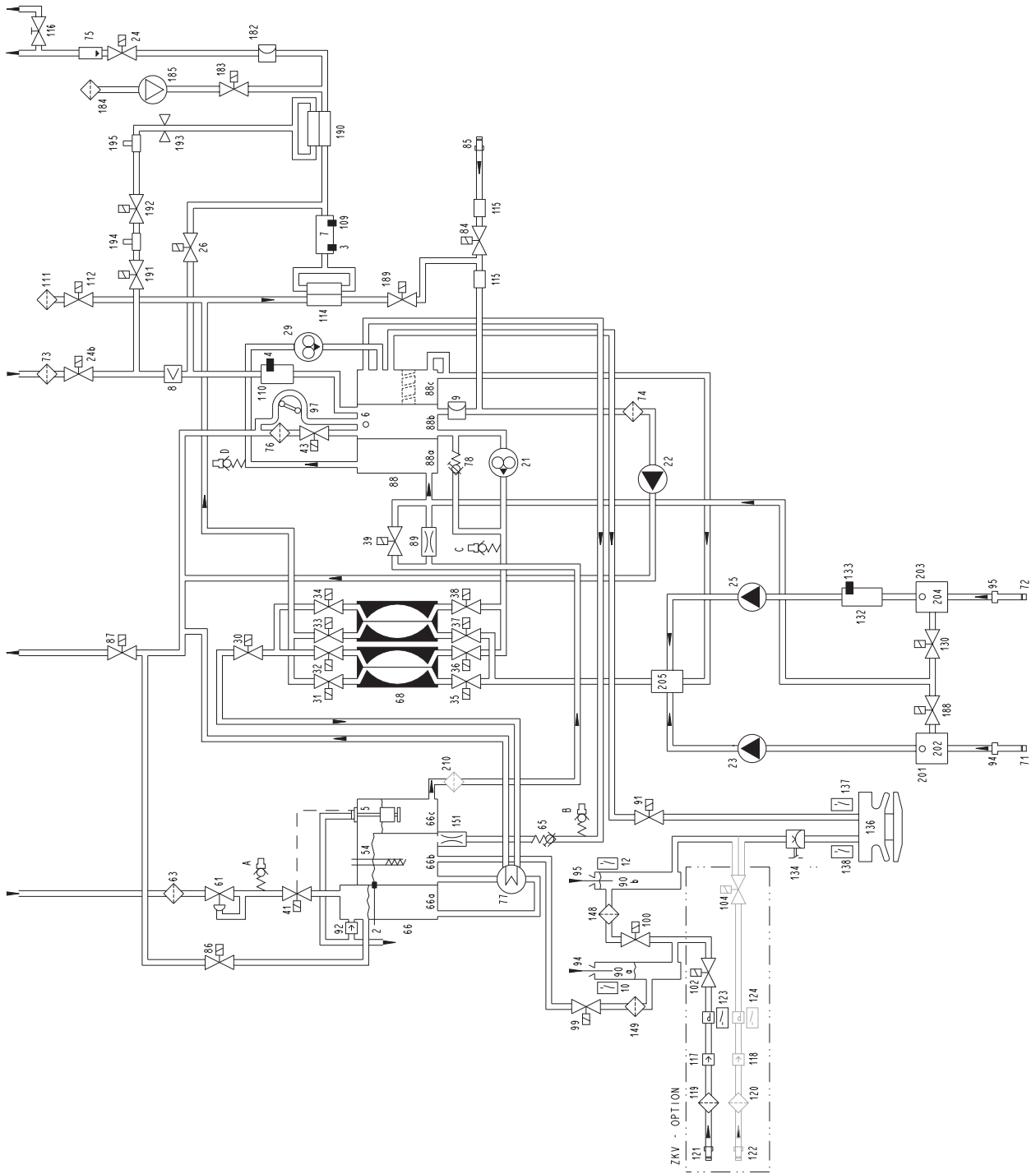

Legend

2	Temperature sensor	92	Vent valve
3	Temperature sensor	94	Concentrate suction tube
4	Temperature sensor (OCM option)	95	Bicarbonate suction tube
5	Float switch	97	Air separation pump
6	Level sensor	99	Rinse valve
7	Conductivity cell	100	Rinse valve
8	Blood leak detector	102	Central concentrate delivery valve
9	Pressure transducer	104	Central bicarbonate delivery valve
10	Reed contact for concentrate	109	Temperature sensor
12	Reed contact for bicarbonate	110	Conductivity measuring cell (OCM option)
21	Flow pump	111	Hydrophobic filter (advanced hydraulics)
22	UF pump	112	Vent valve (advanced hydraulics)
23	Concentrate pump	114	Dialysate filter (Diasafe plus option)
24	Dialyzer valve 1	115	Sensor disinfection valve
24b	Dialyzer valve 2	116	Sampling valve
25	Bicarbonate pump	117	Check valve (concentrate)
26	Bypass valve	118	Check valve (bicarbonate)
29	Degassing pump	119	Filter (concentrate)
30	Outlet valve	120	Filter (bicarbonate)
31	Balancing chamber valve 1	121	Central concentrate delivery connector
32	Balancing chamber valve 2	122	Central bicarbonate delivery connector
33	Balancing chamber valve 3	123	Pressure switch for V102
34	Balancing chamber valve 4	124	Pressure switch for V104
35	Balancing chamber valve 5	125	Temperature compensation plate
36	Balancing chamber valve 6	130	bi bag [®] drain valve
37	Balancing chamber valve 7	132	bi bag [®] conductivity measuring cell
38	Balancing chamber valve 8	133	bi bag [®] temperature sensor
39	Negative pressure valve	134	bi bag [®] pressure transducer
41	Water inlet valve	136	bi bag [®] connector
43	Fill valve	137	bi bag [®] microswitch 1
54	Heater rod	138	bi bag [®] microswitch 2
61	Pressure reducing valve	148	Filter/rinse valve 100
63	Water inlet filter	149	Filter/rinse valve 99
65	Loading pressure valve	151	Orifice
66	Heater block	182	Pressure transducer 2 (advanced hydraulics)
66a	Water inflow chamber	183	Test valve (advanced hydraulics)
66b	Heater rod chamber	184	Test valve filter
66c	Float chamber	185	Compressor (advanced hydraulics)
68	Balancing chamber	188	Evacuation valve
71	Filter/concentrate	189	Retentate valve
72	Filter/bicarbonate	190	Online filter (Online plus option)
73	Filter/dialysate external	191	Online 3 valve (Online plus option)
74	Filter/UF	192	Online 2 valve (Online plus option)
75	External flow indicator	193	Online 1 valve (Online plus option)
76	Filter/fill valve	194	Rinse port (Online plus option)
77	Heat exchanger	195	Substitute port (Online plus option)
78	Relief valve	201	Air separator
84	Disinfectant valve	202	Level sensor
85	Disinfectant connector	203	Air separator
86	Recirculation valve	204	Level sensor
87	Drain valve	205	Concentrate / bicarbonate mixing point
88	Multifunction block	210	Filter (degassing orifice)
88a	Degassing chamber		
88b	Secondary air separator		
88c	Primary air separator		
89	Degassing orifice		
90a	Rinse chamber, concentrate		
90b	Rinse chamber, bicarbonate		
91	Rinse valve		

Hydraulics measuring points

- A Reduced water inlet pressure
- B Balancing chamber loading pressure
- C Flow pump pressure
- D Degassing pump pressure

Fig.: P.C.B. overview

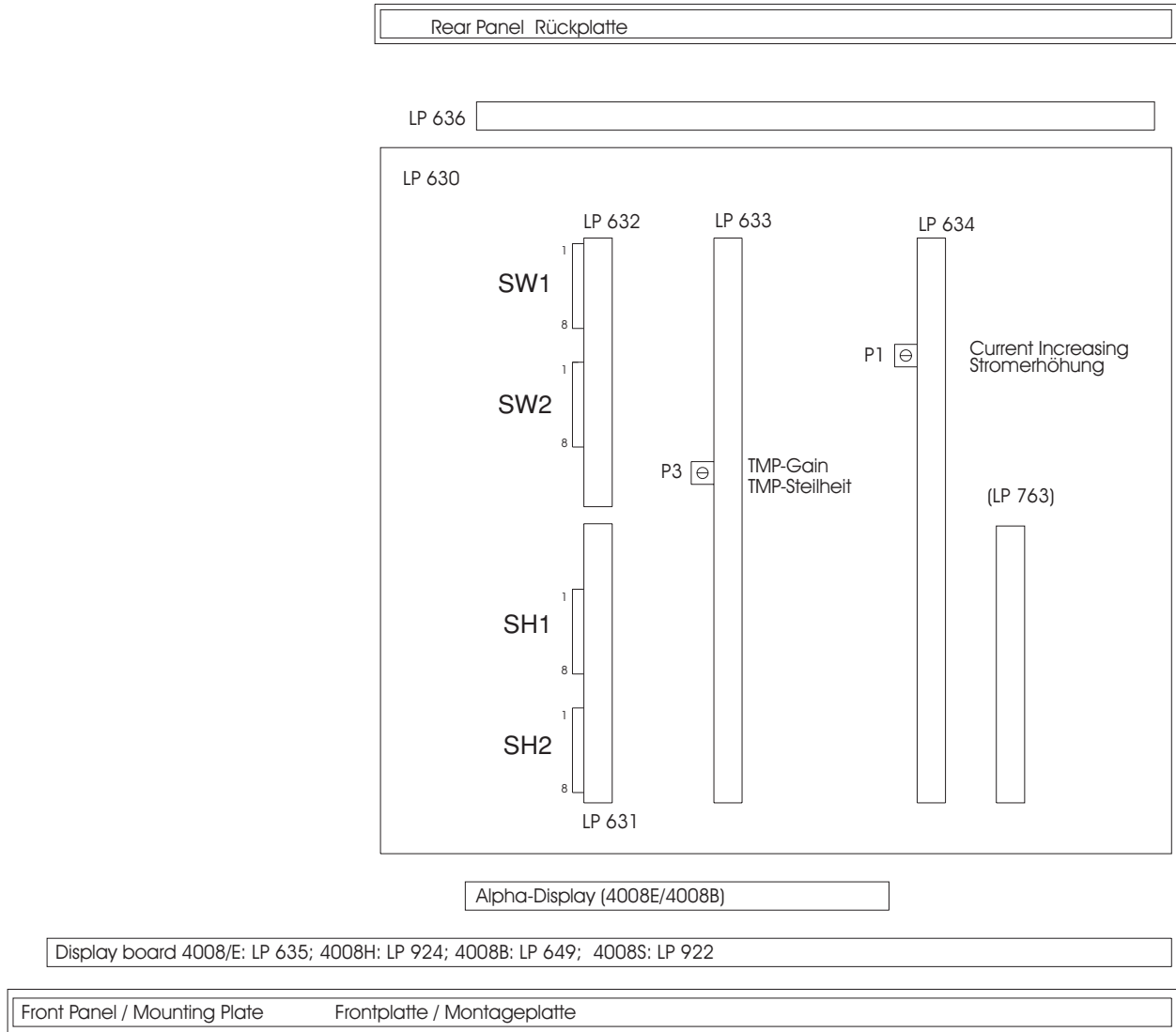

- LP 630 Motherboard
- LP 631 CPU 1 (operating system)
- LP 632 CPU 2 (safety system)
- LP 633 Input board
- LP 634 Output board
- LP 635 Display board
- LP 636 External connectors
- LP 649 Display board 4008 B
- LP 763 Interface board
- LP 924 Display board 4008 H
- LP 922 Display board 4008 S

3.1 Overview of the DIP switches in the 4008

3.1.1 P.C.B. LP 631 (CPU 1) DIP switch array 1



Note

Dip switch 6 is provided for service purposes/troubleshooting only and must be set to the OFF position for dialysis mode.

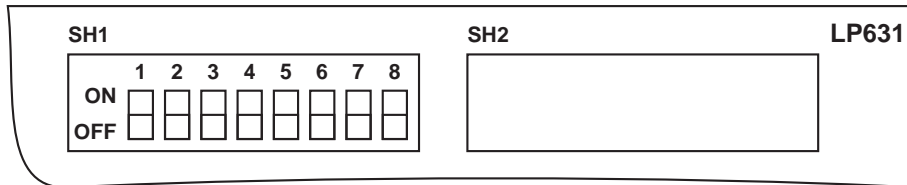

Switch / Position	Function																																																															
<table border="0"> <tr> <td>SW 1</td> <td>SW 2</td> <td></td> </tr> <tr> <td>ON</td> <td>ON</td> <td>max. UF rate</td> </tr> <tr> <td>OFF</td> <td>ON</td> <td>1000 ml/h</td> </tr> <tr> <td><i>ON</i></td> <td><i>OFF</i></td> <td>2000 ml/h</td> </tr> <tr> <td>OFF</td> <td>OFF</td> <td><i>3000 ml/h</i></td> </tr> <tr> <td></td> <td></td> <td>4000 ml/h</td> </tr> </table>	SW 1	SW 2		ON	ON	max. UF rate	OFF	ON	1000 ml/h	<i>ON</i>	<i>OFF</i>	2000 ml/h	OFF	OFF	<i>3000 ml/h</i>			4000 ml/h																																														
SW 1	SW 2																																																															
ON	ON	max. UF rate																																																														
OFF	ON	1000 ml/h																																																														
<i>ON</i>	<i>OFF</i>	2000 ml/h																																																														
OFF	OFF	<i>3000 ml/h</i>																																																														
		4000 ml/h																																																														
<table border="0"> <tr> <td>SW 3</td> <td>SW 4</td> <td>SW 5</td> <td>Language 1</td> <td>Language 2</td> <td>Language 3</td> <td>Language 4</td> </tr> <tr> <td>ON</td> <td>ON</td> <td>ON</td> <td>English</td> <td>English</td> <td>English</td> <td>English</td> </tr> <tr> <td>OFF</td> <td>ON</td> <td>ON</td> <td>German</td> <td>Finnish</td> <td>Japanese</td> <td>Hungarian*</td> </tr> <tr> <td>ON</td> <td>OFF</td> <td>ON</td> <td>French</td> <td>Czech</td> <td>Bulgarian</td> <td></td> </tr> <tr> <td>OFF</td> <td>OFF</td> <td>ON</td> <td>Portuguese</td> <td>Danish</td> <td>Greek</td> <td></td> </tr> <tr> <td>ON</td> <td>ON</td> <td>OFF</td> <td>Dutch</td> <td>Russian</td> <td>Arabic*</td> <td></td> </tr> <tr> <td>OFF</td> <td>ON</td> <td>OFF</td> <td>Italian</td> <td>Turkish</td> <td>Norwegian*</td> <td></td> </tr> <tr> <td>ON</td> <td>OFF</td> <td>OFF</td> <td>Swedish</td> <td>Polish</td> <td>Slovenian*</td> <td></td> </tr> <tr> <td>OFF</td> <td>OFF</td> <td>OFF</td> <td>Spanish</td> <td>Slovakian</td> <td>Ex-Yugoslavian*</td> <td></td> </tr> </table>	SW 3	SW 4	SW 5	Language 1	Language 2	Language 3	Language 4	ON	ON	ON	English	English	English	English	OFF	ON	ON	German	Finnish	Japanese	Hungarian*	ON	OFF	ON	French	Czech	Bulgarian		OFF	OFF	ON	Portuguese	Danish	Greek		ON	ON	OFF	Dutch	Russian	Arabic*		OFF	ON	OFF	Italian	Turkish	Norwegian*		ON	OFF	OFF	Swedish	Polish	Slovenian*		OFF	OFF	OFF	Spanish	Slovakian	Ex-Yugoslavian*		
SW 3	SW 4	SW 5	Language 1	Language 2	Language 3	Language 4																																																										
ON	ON	ON	English	English	English	English																																																										
OFF	ON	ON	German	Finnish	Japanese	Hungarian*																																																										
ON	OFF	ON	French	Czech	Bulgarian																																																											
OFF	OFF	ON	Portuguese	Danish	Greek																																																											
ON	ON	OFF	Dutch	Russian	Arabic*																																																											
OFF	ON	OFF	Italian	Turkish	Norwegian*																																																											
ON	OFF	OFF	Swedish	Polish	Slovenian*																																																											
OFF	OFF	OFF	Spanish	Slovakian	Ex-Yugoslavian*																																																											
<table border="0"> <tr> <td>SW 6</td> <td></td> <td>CRC/RAM test</td> </tr> <tr> <td>ON</td> <td></td> <td>skip</td> </tr> <tr> <td><i>OFF</i></td> <td></td> <td><i>perform</i></td> </tr> </table>	SW 6		CRC/RAM test	ON		skip	<i>OFF</i>		<i>perform</i>																																																							
SW 6		CRC/RAM test																																																														
ON		skip																																																														
<i>OFF</i>		<i>perform</i>																																																														
<table border="0"> <tr> <td>SW 7</td> <td></td> <td>Heater rod</td> </tr> <tr> <td>ON</td> <td></td> <td>1300 W (at 100 to 120 V)</td> </tr> <tr> <td><i>OFF</i></td> <td></td> <td><i>1600 W (at 220 to 240 V)</i></td> </tr> </table>	SW 7		Heater rod	ON		1300 W (at 100 to 120 V)	<i>OFF</i>		<i>1600 W (at 220 to 240 V)</i>																																																							
SW 7		Heater rod																																																														
ON		1300 W (at 100 to 120 V)																																																														
<i>OFF</i>		<i>1600 W (at 220 to 240 V)</i>																																																														
<table border="0"> <tr> <td>SW 8</td> <td></td> <td>Test and cleaning flow</td> </tr> <tr> <td>ON</td> <td></td> <td>500 ml/min</td> </tr> <tr> <td><i>OFF</i></td> <td></td> <td><i>800 ml/min</i></td> </tr> </table>	SW 8		Test and cleaning flow	ON		500 ml/min	<i>OFF</i>		<i>800 ml/min</i>																																																							
SW 8		Test and cleaning flow																																																														
ON		500 ml/min																																																														
<i>OFF</i>		<i>800 ml/min</i>																																																														

The basic position upon delivery is shown in italics.
For "not used" the switch must be set to OFF.

* 4008 H/S only

3.1.2 P.C.B. LP 631 (CPU 1) DIP switch array 2

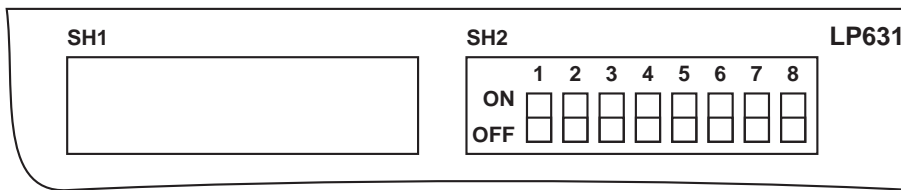

Switch / Position	Function
SW 1 ON <i>OFF</i>	CAL mode Mode 0 <i>Mode 1</i>
SW 2 SW 3 ON ON OFF ON ON OFF <i>OFF</i> <i>OFF</i>	Ext. alarm input Invalid RO system Patient bell <i>Ext. alarm</i>
SW 4 ON <i>OFF</i>	Remote control System with remote control <i>System without remote control</i>
SW 5 ON <i>OFF</i>	COMMCO LP 763 or LP 758 or LP 729 Enabled <i>Disabled</i>
SW 6 ON <i>OFF</i>	COMMCO Special record <i>Standard record</i>
SW 7 ON OFF	Hydraulics test (not CDS) Active Inactive
SW 8 ON OFF	Central delivery system Installed Not installed

*The basic position upon delivery is shown in italics.
 For "not used" the switch must be set to OFF.*

3.1.3 P.C.B. LP 632 (CPU 2) DIP switch array 1



Note

DIP switches 3 and 8 permit to skip test steps which are requested by the system.
 If the switches are set to the “can be skipped” position, it is important to know that the operator can then bypass the automatic test of the safety systems.
 The person demanding this switch position shall be solely responsible for such a procedure.

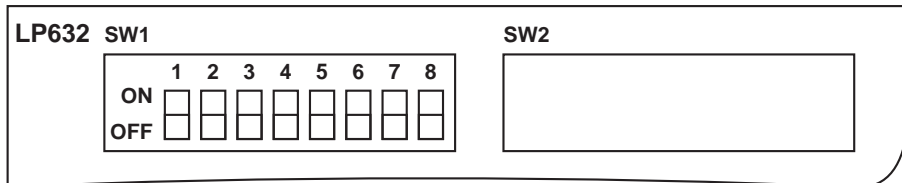

Switch / Position	Function
SW 1 ON <i>OFF</i>	<i>Not used</i>
SW 2 ON <i>OFF</i>	T1 test serial sequence <i>parallel sequence</i>
SW 3 ON <i>OFF</i>	T1 test skip <i>mandatory</i>
SW 4 ON <i>OFF</i>	Test service “ON” (individual test steps can be selected, dialysis not possible) “OFF” (<i>automatic T1 test</i>)
SW 5 ON <i>OFF</i>	Cyclic PHT every 2 minutes and indication of the test result (service) <i>every 12.5 minutes, alarm emission only with cyclical PHT alarm</i>
SW 6 <i>ON</i> OFF	Cyclic PHT “ON” “OFF”
SW 7 ON <i>OFF</i>	Air detector with PCB LP 450 without AD28 <i>with PCB LP 450-2 or with AD28</i>
SW 8 ON <i>OFF</i>	HDF test can be skipped <i>mandatory</i>

*The basic position upon delivery is shown in italics.
 For “not used” the switch must be set to OFF.*

3.1.3 P.C.B. LP 632 (CPU 2) DIP switch array 2

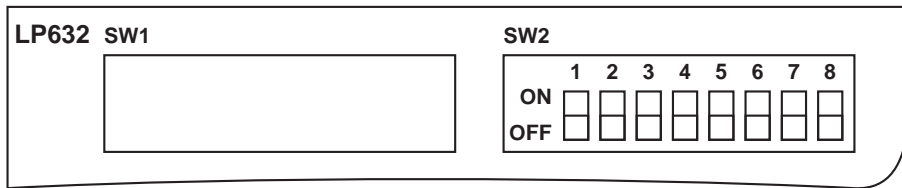

Switch / Position	Function
SW 1 ON OFF	DIASAFE / DIASAFE^{®plus} On Off
SW 2 ON OFF	ON-LINE-HDF On Off
SW 3 ON OFF	ONLINE^{plus}™ On Off
SW 4 ON OFF	Hydraulics with WTR withoutWTR
SW 5 ON <i>OFF</i>	V39 Test On <i>Off</i>
SW 6 ON <i>OFF</i>	Fast heating HDIS deactivated <i>activated</i>
SW 7 ON <i>OFF</i>	<i>Not used</i>
SW 8 ON <i>OFF</i>	<i>Not used</i>

*The basic position upon delivery is shown in italics.
For "not used" the switch must be set to OFF.*

3.2 Calibration mode

3.2.1 Basic conditions

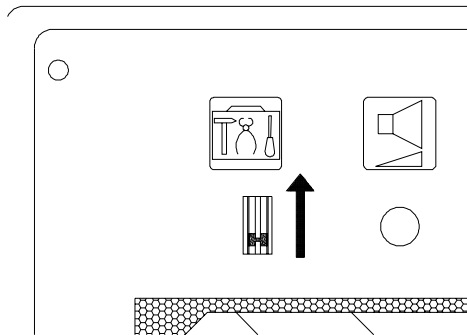

- The hemodialysis system must be switched off.
- The service switch must be in the **ON** (up) position.
- Turn the hemodialysis system on.



Caution

If the Service switch is set to ON during the treatment or the cleaning program, the heater relay will be turned off.

3.2.2 Messages on the displays on the UF monitor (4008 E/B) or on the screen (4008 H/S)

- 4008/E/B

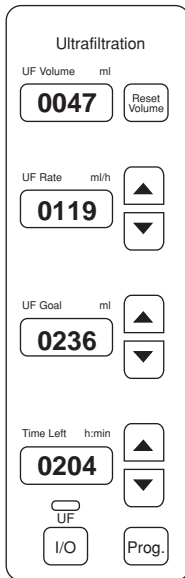

Watchdog supply voltage
(4.5 V to 5.5 V)

12-V voltage (11.5 V to 12.5 V)

24-V voltage (23 V to 25 V)

Battery charging voltage (> 20 V)

The values indicated on the display must be divided by the factor 10.

Values in brackets: tolerances

- 4008 H/S

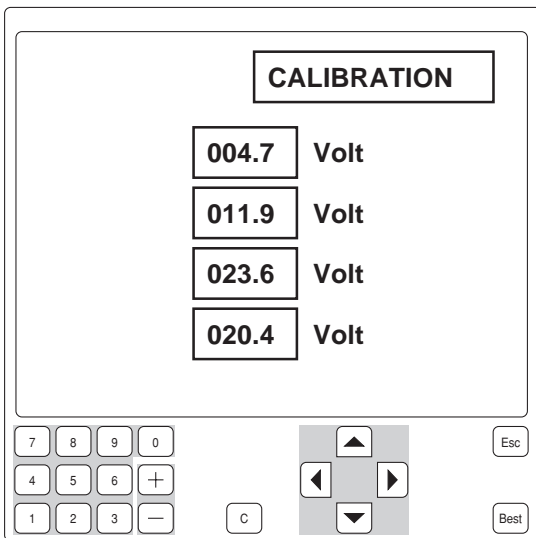

Watchdog supply voltage (4.5 V – 5.5 V)

12 V voltage (11.5 V – 12.5 V)

24 V voltage (23 V – 25 V)

Battery charging voltage (> 20 V)

3.3 Hydraulics



Note

Measuring equipment for measurement points in the hydraulic unit:
UMED, HMED or pressure gauge with a measuring range of
-1 to +2.2 bar, min. quality class 1.6.

3.3.1 Reduced water inlet pressure

Measuring equipment: UMED, HMED or pressure gauge

Place of measurement: Hydraulics, measurement port A

Condition: Flow on

Check/adjustment:

– **Checking the reduced water inlet pressure**

Connect the measuring equipment to measurement port A.

Measure the water pressure with MV 41 closed.

Rated value of water inlet pressure: 0.90 to 1.40 bar

If it deviates from the rated value, the water inlet pressure must be adjusted.

– **Adjusting the reduced water inlet pressure**

Pull back the knurled nut on the pressure reducing valve (16).

Turn the knurled nut to set the water pressure to the desired value (clockwise: +, counter-clockwise: –).

Push the knurled nut back in.

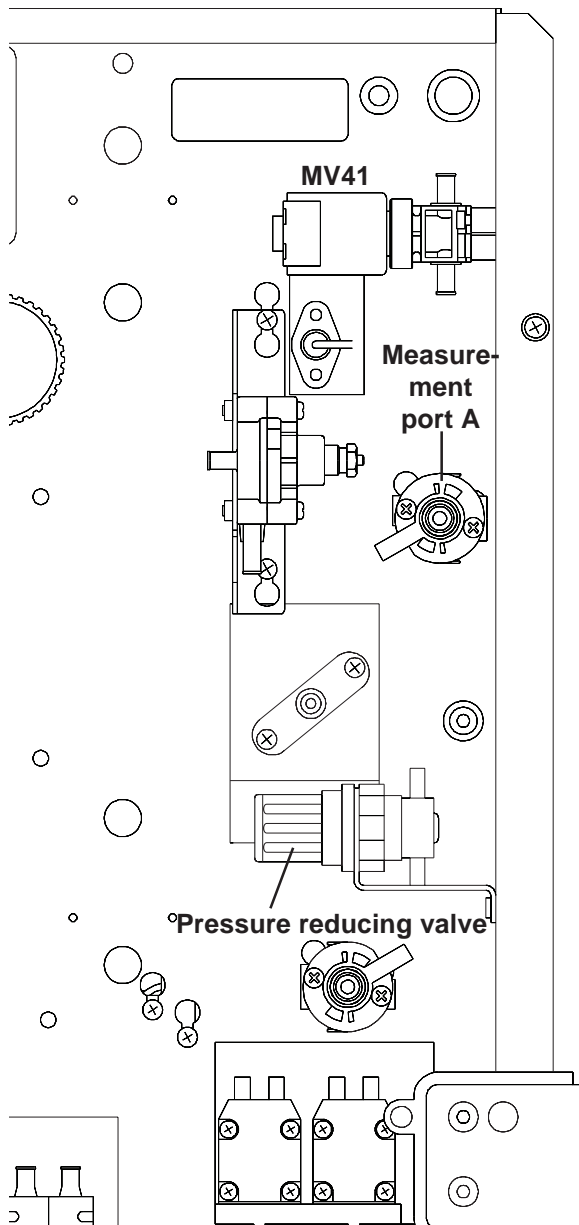

4008 E/H

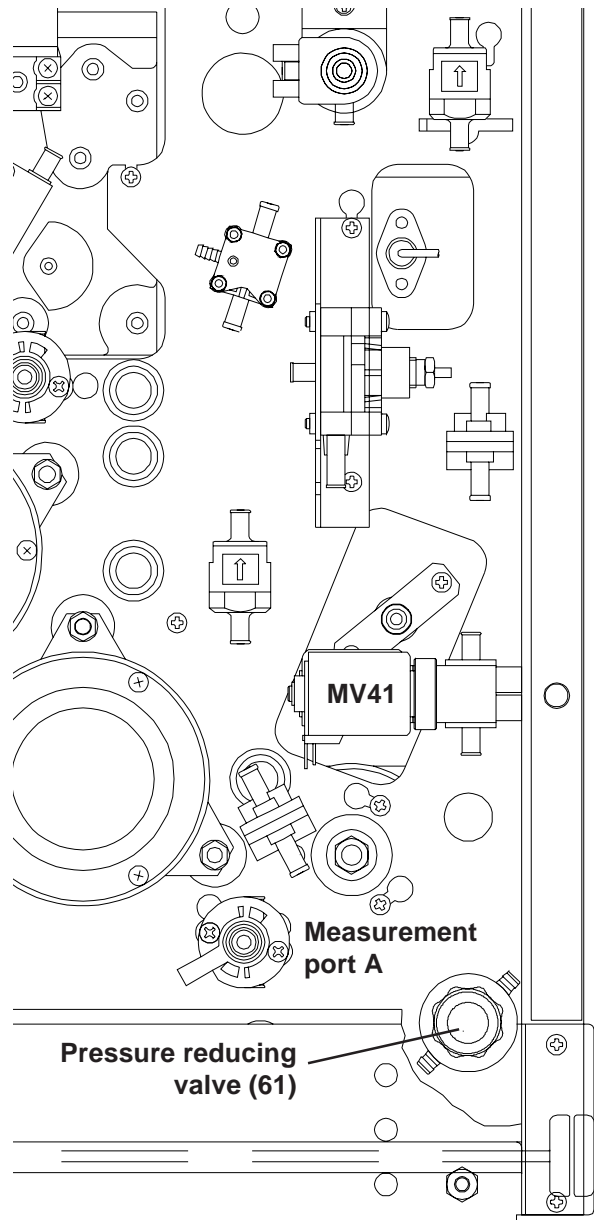

4008 B/S

3.3.2 Degassing pump pressure

Measuring equipment: UMED, HMED or pressure gauge

Place of measurement: Hydraulics, measurement port D

Check/adjustment:

– **Checking the pressure of the degassing pump**

Connect the measuring equipment to the measurement port D.

Measure the pressure of the degassing pump.

Rated value of degassing pump pressure: -0.81 to -0.85 bar

If it deviates from the rated value, the pressure of the degassing pump must be adjusted.

– **Adjusting the pressure of the degassing pump**

Enter the **CALIBRATION** menu, select and start the option **CAL. DEGAS. PRESSURE**

(→ Calibration, chapter 4, section 7).



Note

If the pressure of the degassing pump was changed, make sure to check the loading pressure and readjust, if necessary.

● **Calibration of the negative degassing pressure on higher situated installation sites**

If 4008 systems are operated on higher situated sites (observe sea level), the specified negative degassing pressure can not be reached. The calibration has to be performed as follows:

The setting for the degassing pump has to be increased in increments from a low speed until no significant increase of the negative pressure can be detected anymore.

This setting can also be stored.

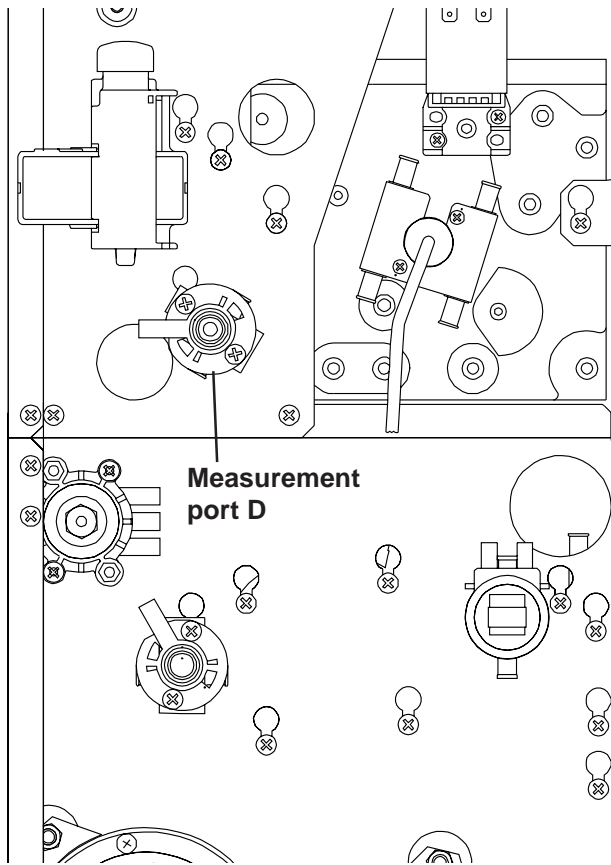

4008 E/H

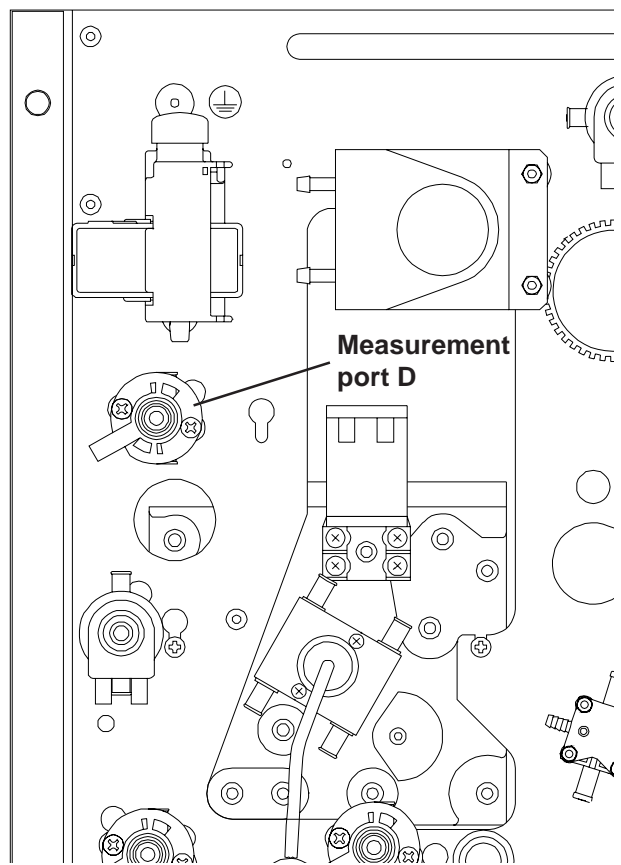

4008 B/S

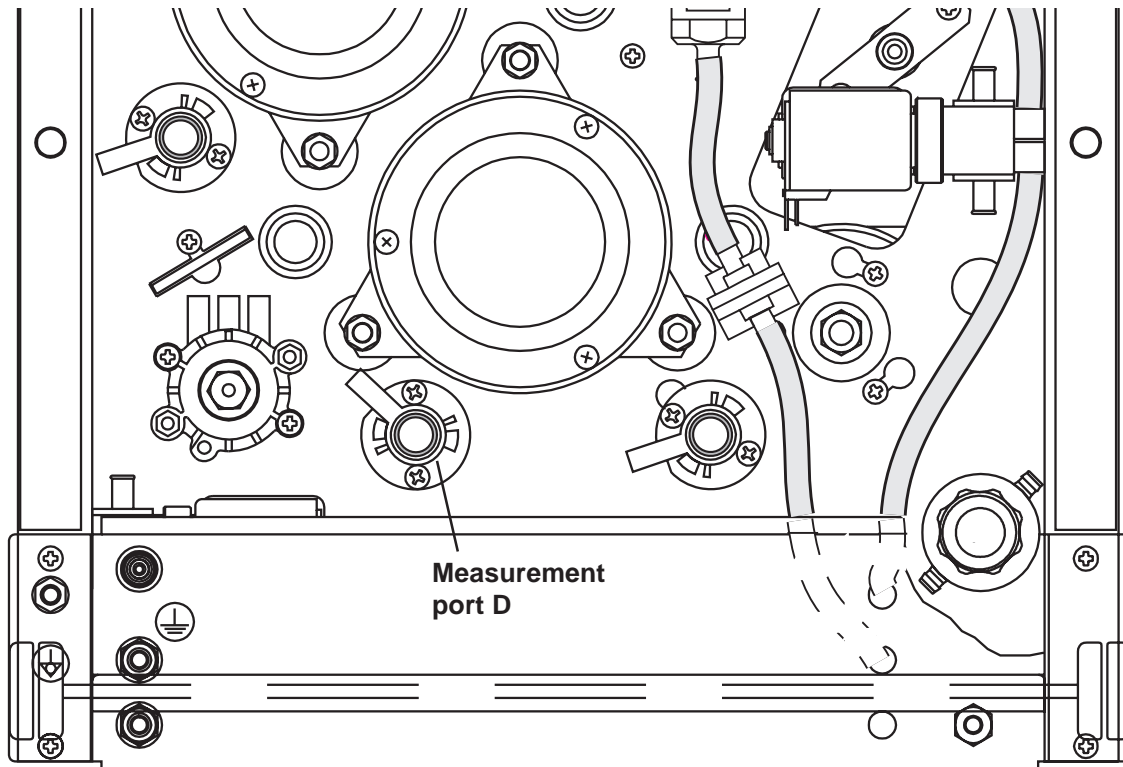

4008 B/S ONLINE^{plus}™

3.3.3 Balancing chamber loading pressure

Measuring equipment: UMED, HMED or pressure gauge

Place of measurement: Hydraulics, measurement port B

Check/adjustment:

– **Checking the loading pressure of the balancing chamber**

Connect the measuring equipment to the measurement port B.

Measure the loading pressure of the balancing chamber.

Rated value of the balancing chamber loading pressure: 1.2 to 1.3 bar

With 4008 B EC495, 4008 H EC 295, 4008 S EC 275 or higher (change of the compression spring in the loading pressure valve): The loading pressure of the balancing chamber has been increased to 1.45 bar \pm 0.05 bar.

If it deviates from the rated value, the loading pressure of the balancing chamber must be adjusted.

– **Adjusting the loading pressure of the balancing chamber**

Use the loading pressure valve (65) to adjust the loading pressure to the rated value.

Turning the adjusting screw clockwise will increase the loading pressure.



Note

During the balancing chamber fill phase, the loading pressure drops to approx. 1.0 bar.



Note

If the loading pressure was changed, make sure to check the degassing pump pressure and readjust, if necessary.

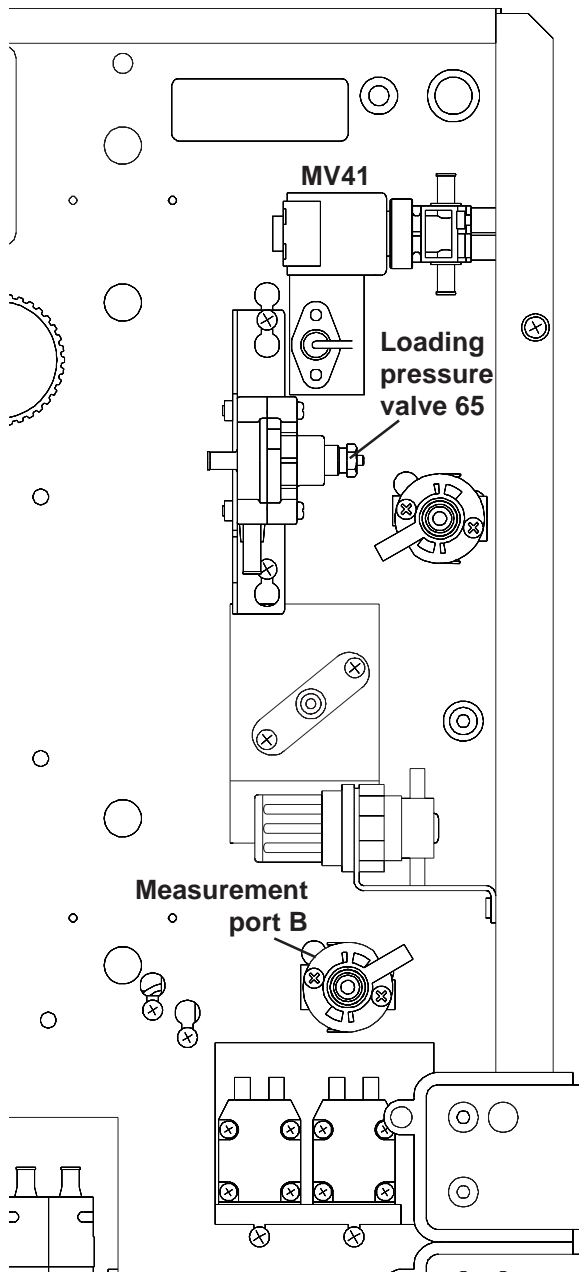

4008 E/H

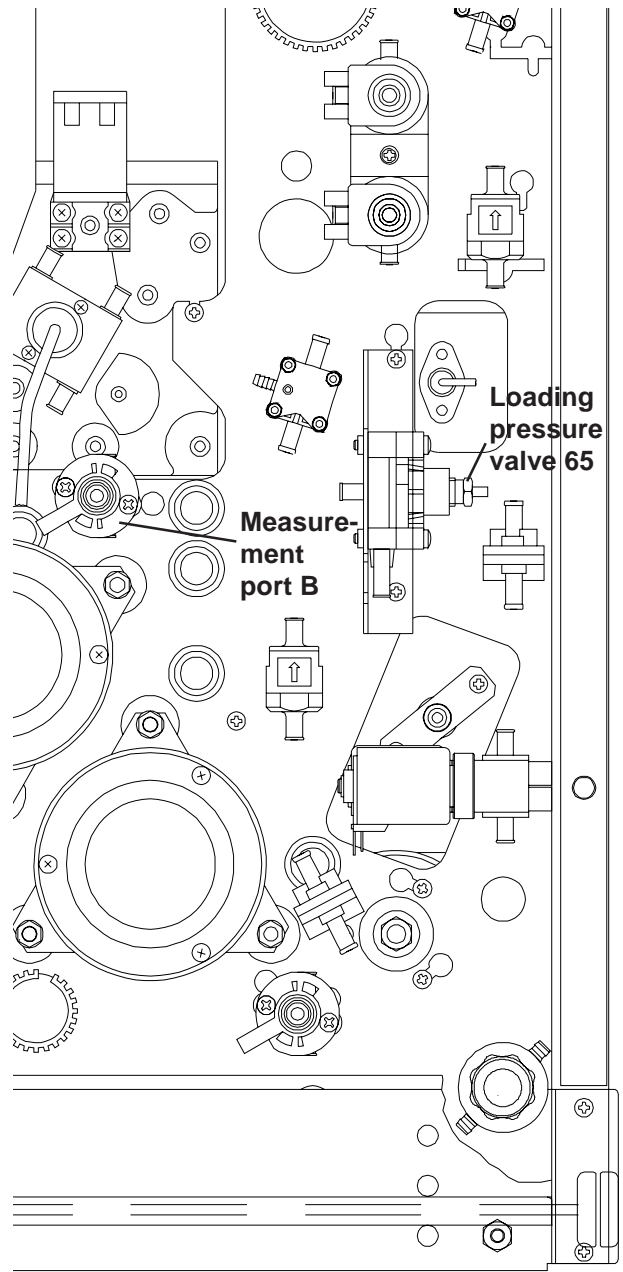

4008 B/S

3.3.4 Flow pump pressure

Measuring equipment: UMED, HMED or pressure gauge

Place of measurement: Hydraulics, measurement port C

Prerequisite: A dialysate flow of 800 ml/min must have been preselected.

Check/adjustment:

– **Checking the pressure of the flow pump**

Connect the measuring equipment to the measurement port C.

Turn the water supply off; water alarm; balancing chamber inactive.

Measure the pressure of the flow pump.

The desired pressure value of the flow pump depends on the loading pressure set:

Loading pressure: 1.2 to 1.3 bar 1.9 to 2.1 bar

Flow pump pressure: 1.45 ± 0.05 bar 2.2 ± 0.05 bar

If it deviates from the rated value, the pressure of the flow pump must be adjusted.

– **Adjusting the pressure of the flow pump**

Use the relief valve (78) to adjust the rated value.

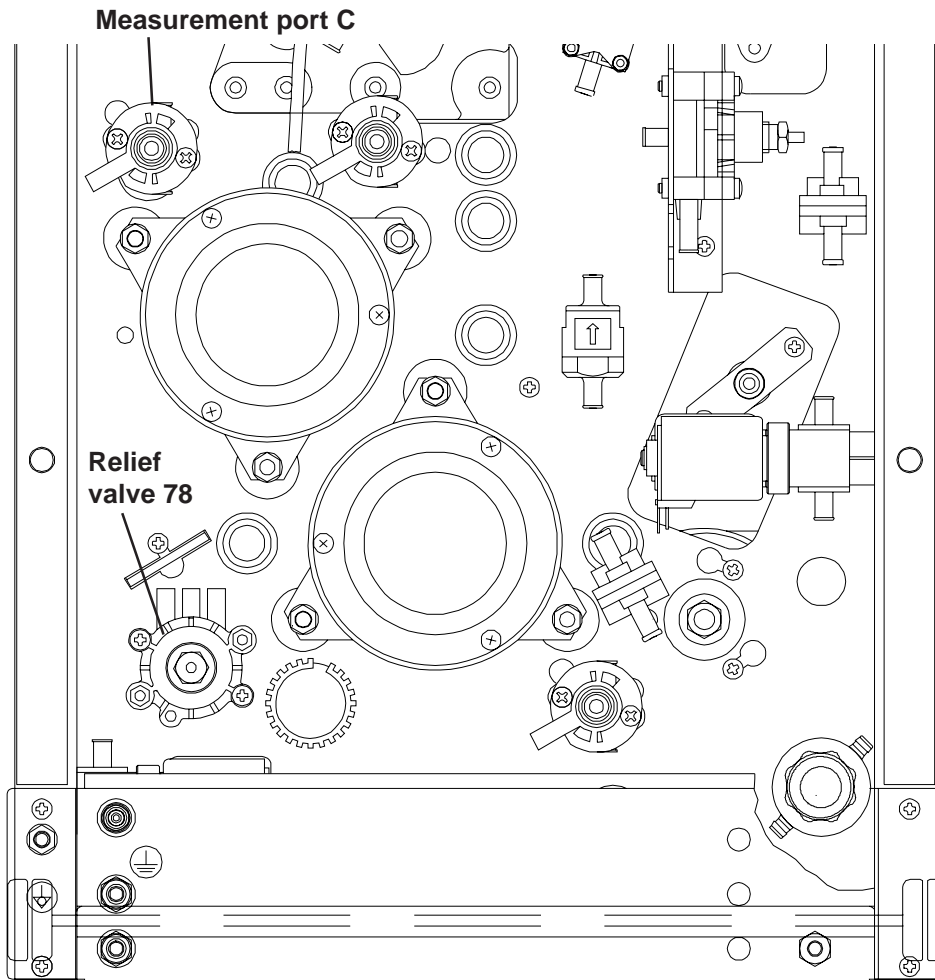

4008 B/S

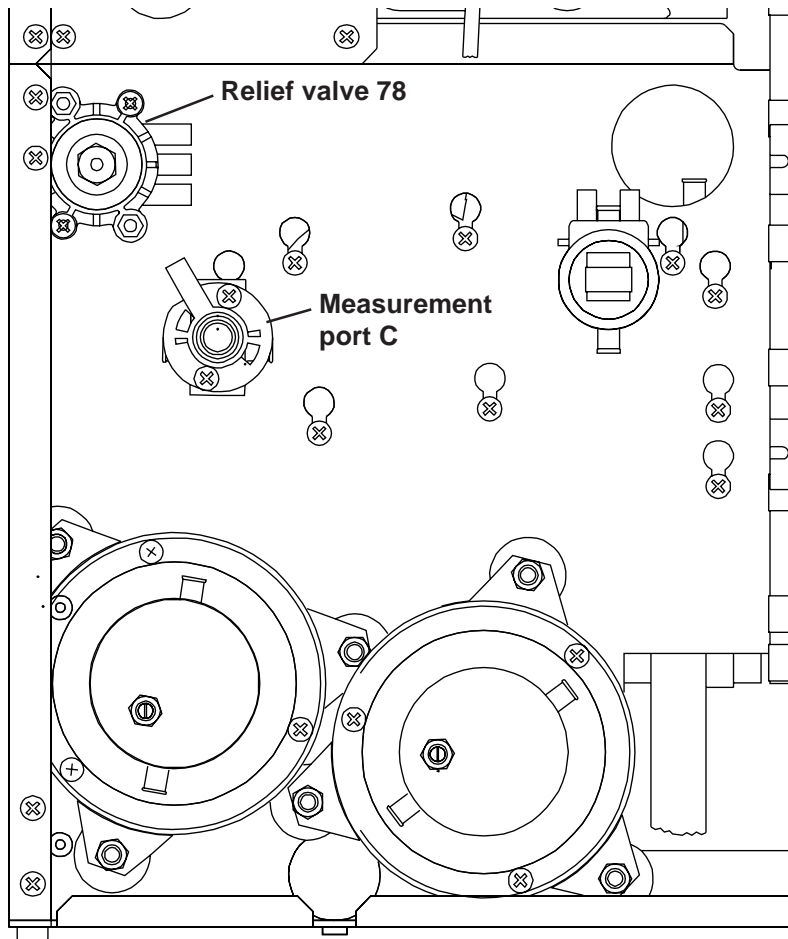

4008 E/H

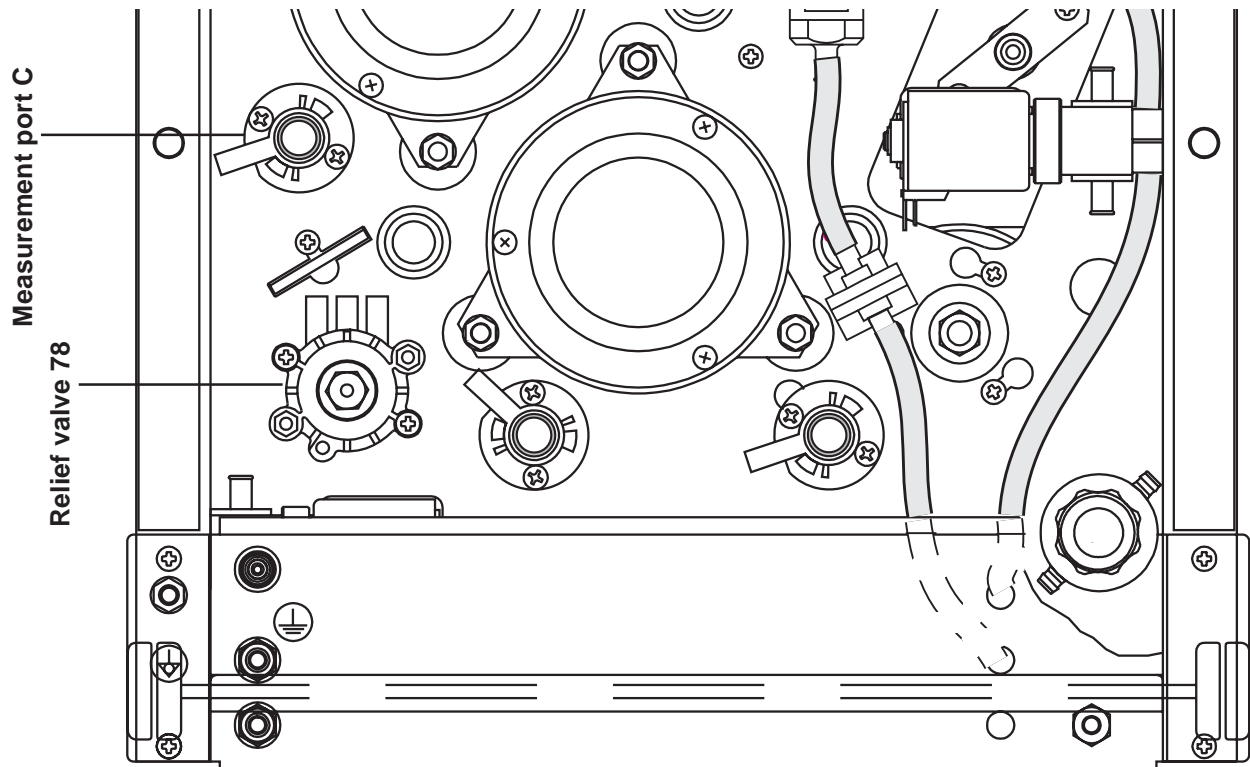

4008 B/S ONLINEplus™

3.3.5 UF pump volume

**Note**

If scales are used for measuring, it must be ensured that no concentrate is connected.

Measuring equipment: Scales or measuring cylinder, tolerance $\pm 0.5\%$

Place of measurement: Hydraulic unit open

Condition: Calibration program selected

Check/adjustment:**– Checking the UF pump volume**

Remove the drain line of the UF pump from the T-piece (close the T-piece).

Place the drain line in the measuring cylinder.

Access the **CALIBRATION** menu, select and start the **ADJ. UF-PUMP VOLUME** option (→ Calibration, chapter 4, Part 6).

Rated value: number of strokes in ml or g $\pm 1\%$.

– Adjusting the UF pump

Remove the protective cover.

Unscrew the lock nut.

Change the delivery volume, using the adjusting screw (turning the adjusting screw clockwise reduces, turning it counter-clockwise increases the stroke volume).

Retighten the lock nut.

Verify the delivery volume.

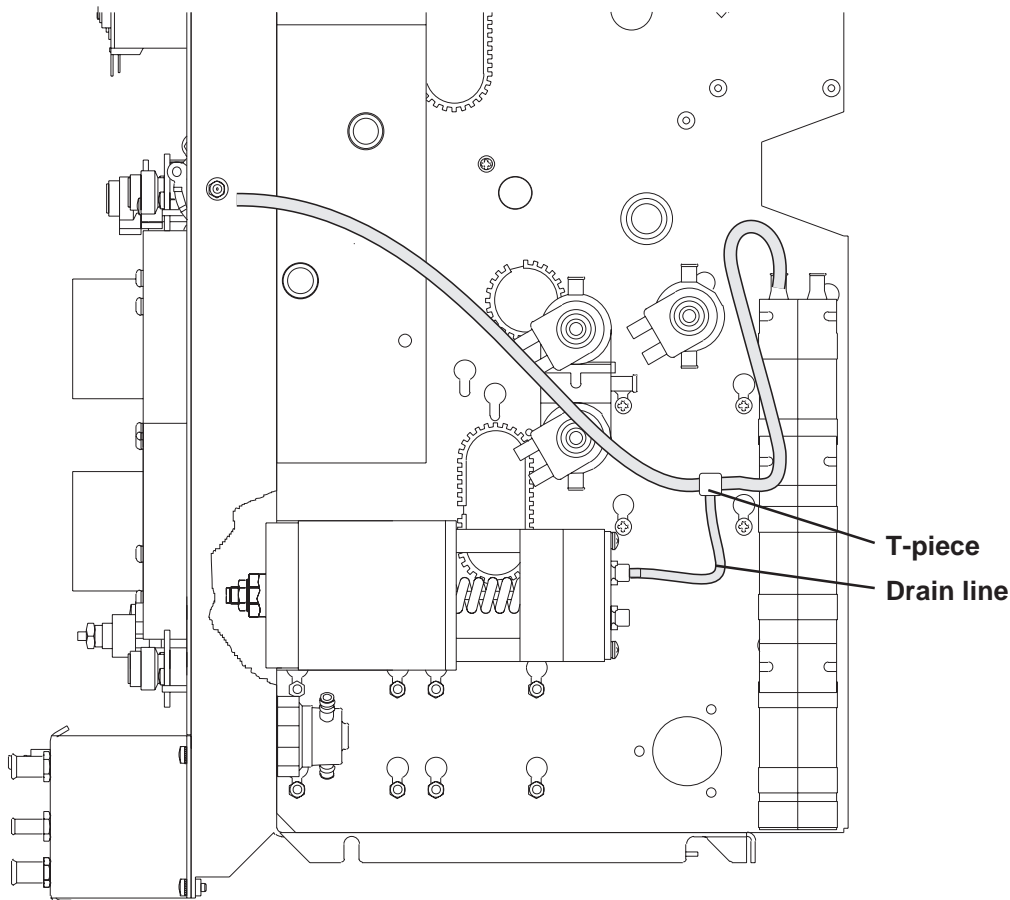

4008 B/S

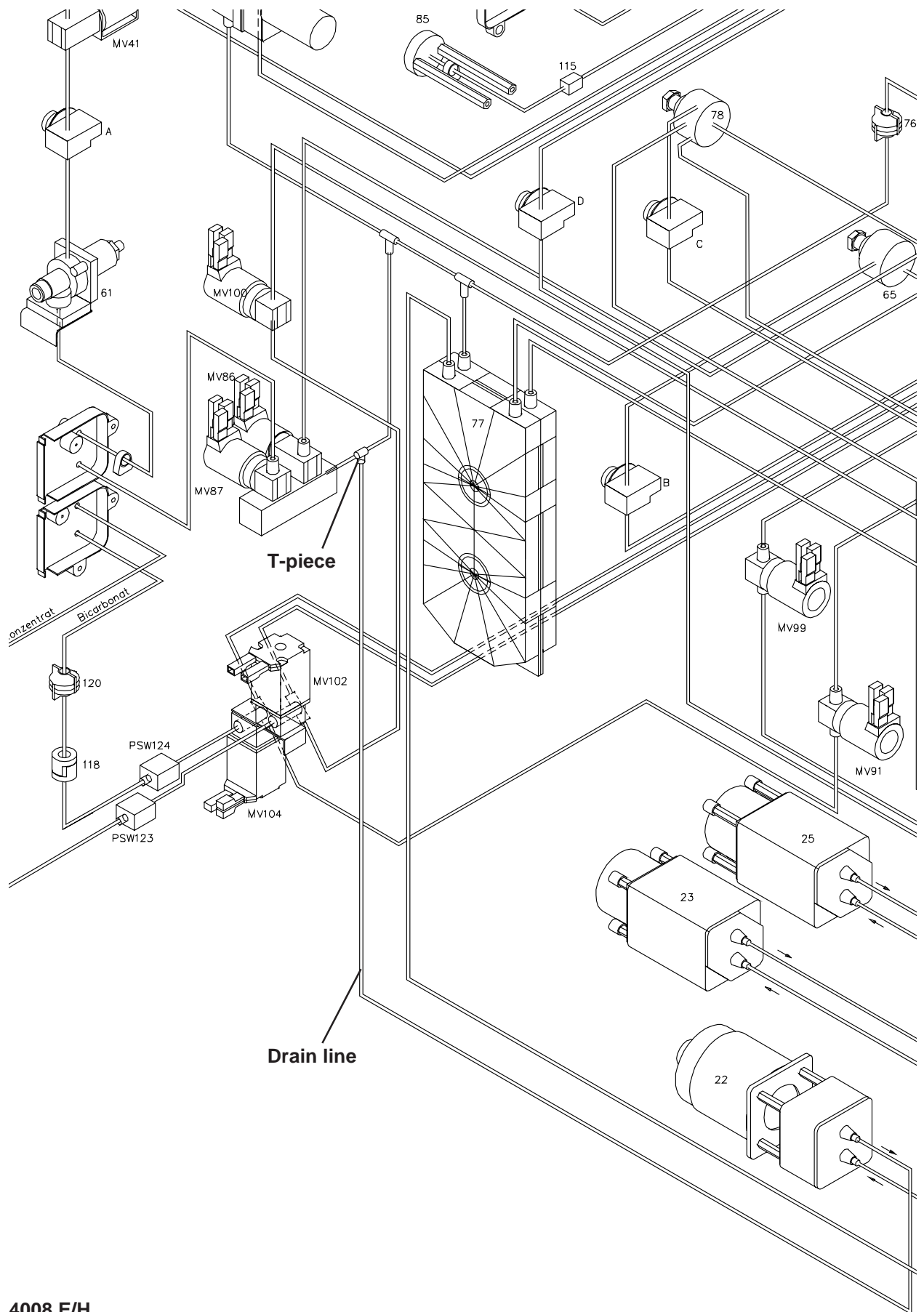

4008 E/H

3.3.6 CDS pressure switch

Measuring equipment: Measurement setup according to diagram, UMED, HMED or pressure gauge (e.g. 0 to 1 bar, accuracy $\pm 1\%$), syringe

Place of measurement: Hydraulic unit open

Condition: The CDS connectors in position 121 and position 122 must be depressurized.
The pressure compensation port on the pressure switch must be open to air (atmospheric pressure).
The lines of the measuring equipment should be as short as possible.
The service mode must be selected.

Check/adjustment:

- Connect the measuring equipment as illustrated in the diagram.
- Select the DIAGNOSTICS menu:
READ INPUTS
READ DIGITAL INPUTS
CPU1: RD DIGITAL INP
I: CPU1_PSW_V102 or I: CPU1_PSW_104
- Activate the audible alarm by pressing the **(Alarm) Tone Mute** key (depressurized: alarm on).
- During these menu options, the solenoid valves MV102 and MV104 are closed.
- Use the syringe to create a pressure of 0.7 bar.
- Use forceps to clamp the line at point **a**, so that the pressure switch remains loaded with 0.7 bar.
- Verify the switching point by means of the audible alarm
Rated values:
Alcatel pressure switch (part no.: 674 322 1) (yellow): 0.68 – 0.80 bar
Delta pressure switch, dark grey: 0.68 – 0.72 bar
Envec pressure switch: 0.68 – 0.72 bar
If the switching point deviates, adjust with the adjusting screw **b** (make sure there is no mechanical load on the pressure switch while adjusting).
- After completed adjustment, depressurize the measuring equipment and repeat the check. If necessary, repeat the adjustment procedure.

This adjustment procedure simultaneously checks the tightness of the check valves 117 and 118 and the solenoid valves 102 and 104.

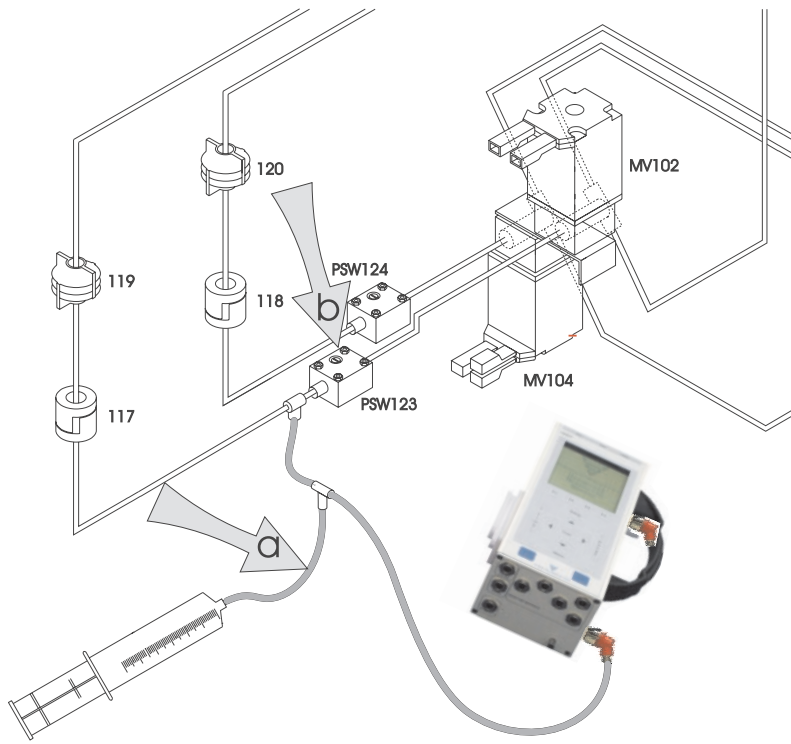

4008 E/H

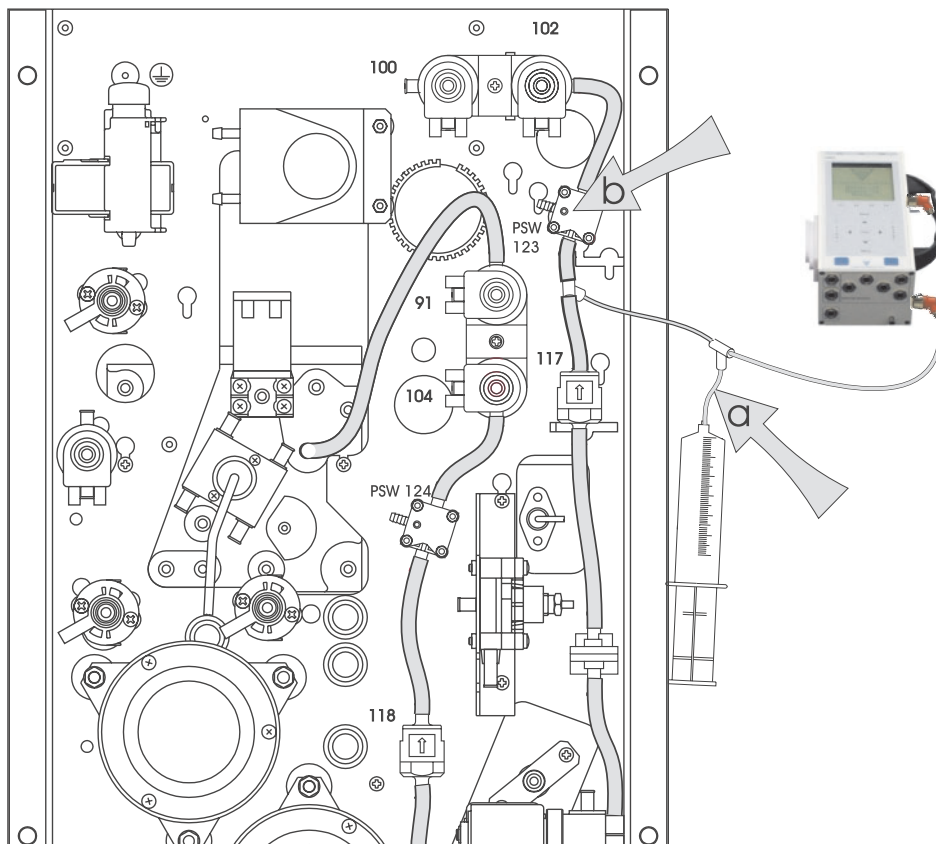

4008 B/S

3.3.7 *bi*bag® pressure transducer calibration

- **General Notes on *bi*bag® pressure transducer calibration**

The calibration described below can be performed by means of a multimeter or the diagnostics program.

In order to read in the corresponding signal, the voltage of AD22 must be measured at pin 1 or the **E: CPU1_BIBAG_PSW** menu item must be selected in the diagnostics program.

The ALCATEL pressure switch is calibrated in the diagnostics program of the dialysis system.

The calibration of the Envec pressure switch is neither possible nor required. These pressure switches are set to a fixed position and can be checked in the diagnostics program.

The audible signal can be activated by pressing the **TONE MUTE** key.

- **Selection in the Diagnostics program**

Turn the hemodialysis system off.
Set the Service switch to **ON** (up).
Turn the hemodialysis system on.



Use the ▲ and ▼ keys to select **DIAGNOSTICS**.
Press the **Confirm** key.



Use the ▲ and ▼ keys to select **READ INPUTS**.
Press the **Confirm** key.



Use the ▲ and ▼ keys to select **READ DIGITAL INPUTS**.
Press the **Confirm** key.



Use the ▲ and ▼ keys to select **CPU1: RD DIGITAL INP**.
Press the **Confirm** key.



Use the ▲ and ▼ keys to select **E: CPU1_BIBAG_PSW**.
Press the **Confirm** key.

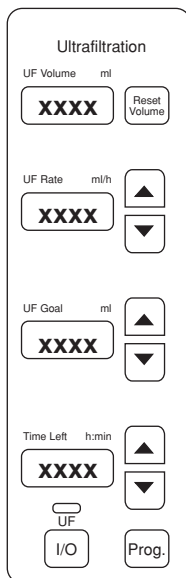

Watchdog supply voltage
(4.5 V to 5.5 V)

12-V voltage (11.5 V to 12.5 V)

24-V voltage (23 V to 25 V)

Battery charging voltage (> 20 V)

The active levels **0000** or **1111** are shown on all UF displays or on the display of dialysis systems with a monitor.



Note

In the menu items **E: CPU1_BIBAG_PSW**, the active level is identified by **1111**.

The active level of the circuit output is LOW (< 1 V).

● Calibration of the ALCATEL pressure switch

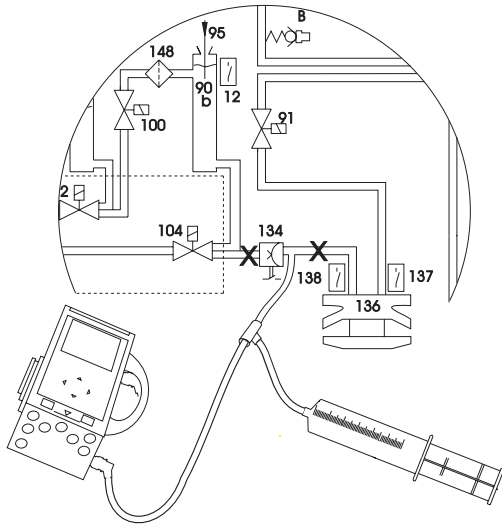

Clamp the lines (X).

Connect the pressure gauge and the syringe and build up a pressure of 100 mbar + 10 mbar.

Turn the potentiometer (AD22 or directly on the pressure switch) until Low Level (< 1 V) (**1111**) is displayed on the UF displays.

Slowly turn the potentiometer into the opposite direction until the High level (> 10 V) (**0000**) is shown on the UF displays.

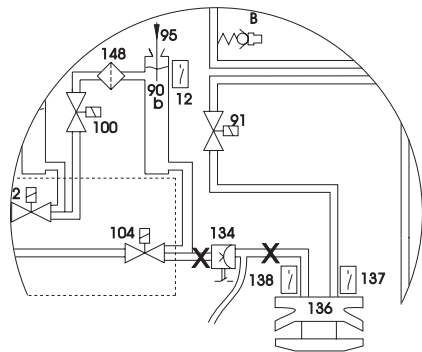

No pressure at the pressure transducer.

UF displays must show High level (**0000**).

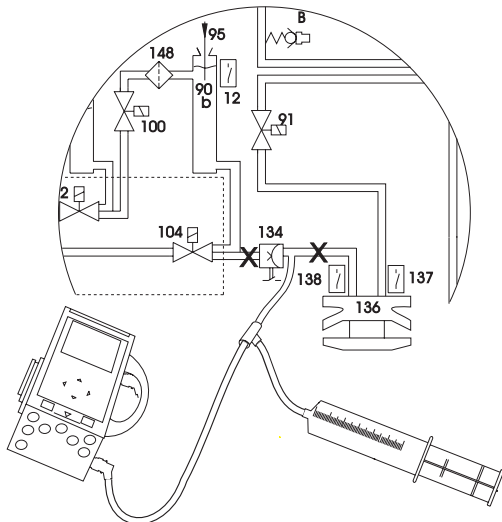

Clamp the lines (X).

Connect the pressure gauge and the syringe and build up a pressure of 160 mbar.

UF displays must show Low level (**1111**).

Slowly reduce the pressure. UF displays must show High level (**0000**) at a minimum of 100 mbar.

If necessary, repeat calibration.

Pressure transducer calibration completed.

3.4 Air detector



Caution

For adjusting the air detector, the system must be in “Calibration” mode. The ambient temperature should range between 15 and 35 °C.



Caution

The calibration using the set for the air detector calibration is only valid for systems used together with Fresenius tubing systems. Observe the “use by” date!

- **Adjusting the air detector LD 22, using the set for the air detector calibration (see also adjustment instructions no. M36 067)**

The system must be in Service mode and the bridge J1 / LP 450 in the calibration position.

Fill the spherical hollow in the adjusting block with grease; remove excess grease with the spatula, so that only the hollows are filled to the brim with grease.

Introduce the greased adjusting block into the drip chamber holder (the slant edges first). During this process, make sure that the ultrasonic sensors neatly engage into the spherical hollows of the normal. The normal must not touch the walls of the holder but hang freely between the sensors.

Turn the potentiometer 1 and then the potentiometer 2 on LP 450 clockwise until LED D5 and LED D10 on LP 450 have turned dark.

Slowly (caution: time constant) turn back the potentiometer 1 / LP 450 until LED D5 on LP 450 is illuminated.

Slowly (caution: time constant) turn back the potentiometer 2 / LP 450 until LED D10 on LP 450 is illuminated.

Plug bridge J1 / LP 450 to the ‘operating’ position.

LED D5 and LED D10 must both be dark.

Take the adjusting block out of the drip chamber and completely remove the grease from the drip chamber holder, using only lint-free cloth and permissible disinfectants.

Check:

Fill the spherical hollows of the checking block with grease and remove any excess grease with a spatula, so that only the hollows are filled to the brim with grease.

Insert the greased checking block into the drip chamber holder. During this process, make sure that the ultrasonic sensors neatly engage into the spherical hollows of the normal. The normal must not touch the walls of the holder but hang freely between the sensors.

Both LED D5 and LED D10 must be illuminated. If one or two of the LEDs is not illuminated, repeat the adjustment process.

Take the checking block out of the drip chamber and completely remove the grease from the drip chamber holder, using only lint-free cloth and permissible disinfectants.

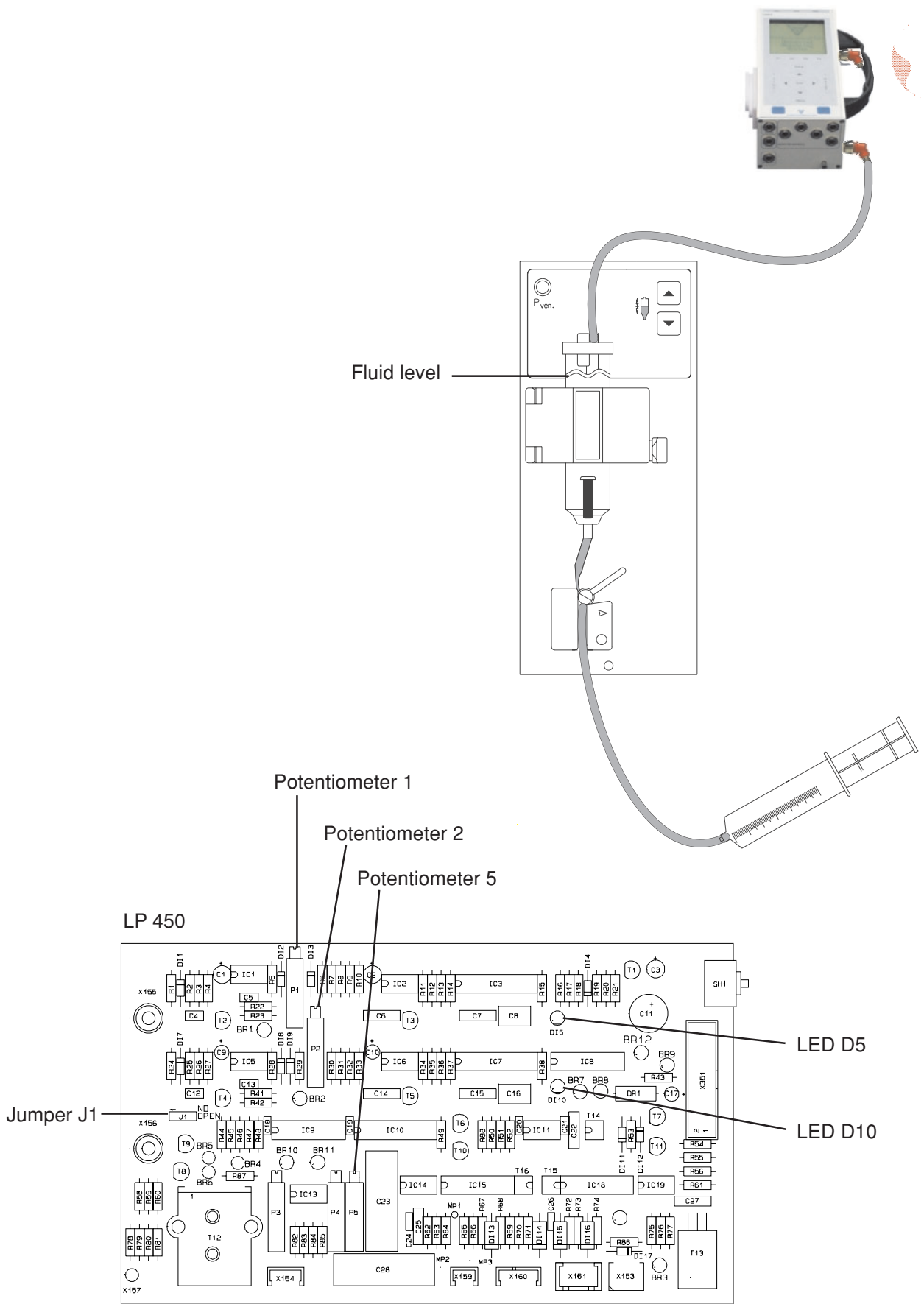

- **Alternative: Adjusting the air detector without the set for the air detector calibration**

Measuring equipment: Measurement setup according to diagram
UMED, HMED or pressure gauge, bubble catcher, syringe filled with degassed water or saline solution

Place of measurement: Air detector

Check / adjustment:

– **Adjusting the ultrasonic detector**

Install the measurement set-up before checking / adjusting the air detector. Do not yet place the line in the occlusion clamp.

Jumper J1 / P.C.B. LP 450 set to calibration.

Fill the bubble catcher. The fluid level must be set to approx. 10 mm above the top edge of the sensor holder.

Turn potentiometer 1 and potentiometer 2 on P.C.B. LP 450 clockwise, until the LED DI5 and LED DI10 on P.C.B. LP 450 are dark.

Slowly (attention: time constant) turn potentiometer 1 on P.C.B. LP 450 counterclockwise, until the LED DI5 on P.C.B. LP 450 lights.

Slowly (attention: time constant) turn the potentiometer 2 on P.C.B. LP 450 counterclockwise, until the LED DI10 on P.C.B. LP 450 lights.

After completion of the calibration procedure, set the jumper J1 / P.C.B. LP 450 back to the operation position.

– **Check**

Lower the level in the bubble catcher: an alarm must be emitted.

Raise the level in the bubble catcher: it must be possible to clear the alarm; both LEDs must be off!

– **Checking the venous line clamp (→ Fig.)**

Place the line in the venous line clamp.

Open the clamp and, using the syringe, generate a pressure of approx. 2 bar.

Close the clamp.

The pressure must not drop by more than 0.1 bar within 3 minutes.

– **Adjusting the optical detector**

Use the gray filter, double-laid, part no. 640 560 1.

Diagnostics menu; reading of digital inputs by CPU 1; item E: CPU1_OD_IN.

Install the gray filter, double-laid; close the hinged cover.

Slowly turn potentiometer P5 on P.C.B. LP 450 clockwise, until the UF display indicates 1111.

Slowly turn potentiometer P5 counterclockwise, until the display jumps to 0000. Continue to turn the potentiometer counterclockwise for half a turn.

Avoid incident light from external sources.

4 Calibration program

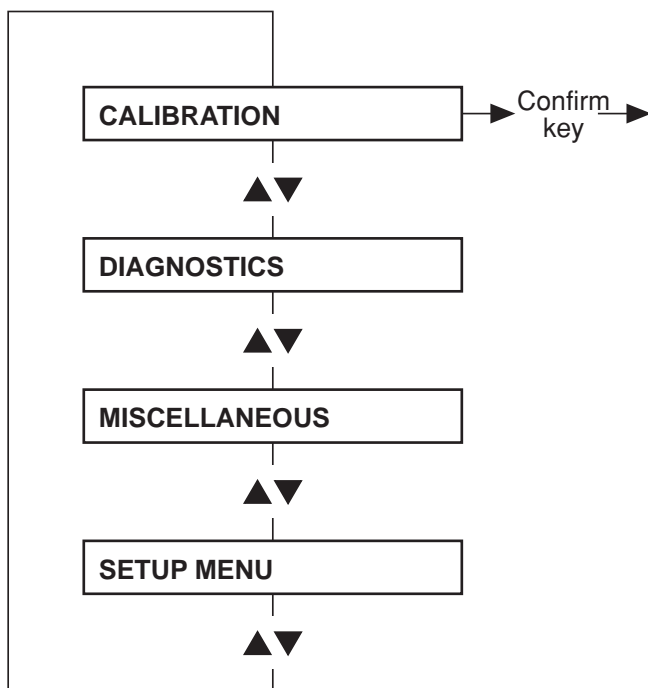

Adjustments made without display messages:

Adjusting the blood pump stop alarm (blood pump or HDF pump)	4-5
Calibrating the Single-Needle blood pump	4-11
Adjusting the current rise pulse	4-15
Adjusting the Hall sensor in the heparin pump	4-43

In the Calibration, Diagnostics, Setup and Miscellaneous program the function of the keys differs between 4008 E/B and 4008 H/S systems.

Function	4008 E/B	4008 H/S
Scrolling through menu options	▲▼	▲▼
Selecting a menu option	Confirm	Conf
Changing values and functions in a menu	▲▼	+/-
Saving changes	Override	Tone Mute
Exiting a menu without saving the data	Select	Esc

In the description of the steps, the differing keys to be used on 4008 H/S systems are shown in brackets.

● Main menu

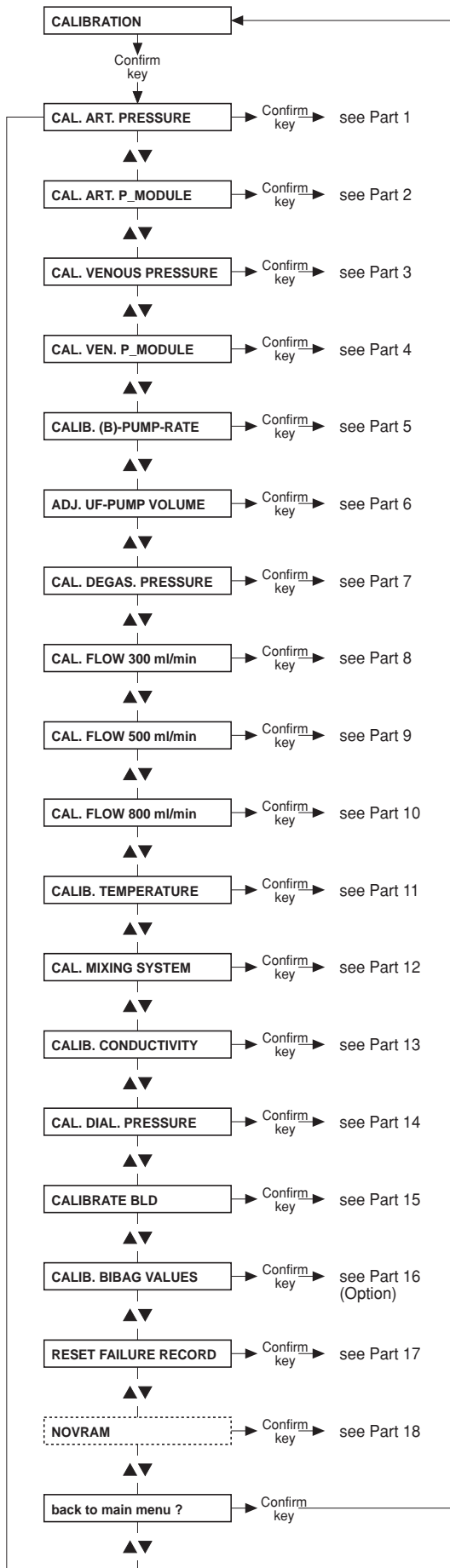

Note

Before calibrating the hydraulics, remove possibly existing precipitate by running an appropriate disinfection program.

● Part 1: Calibrating the arterial pressure

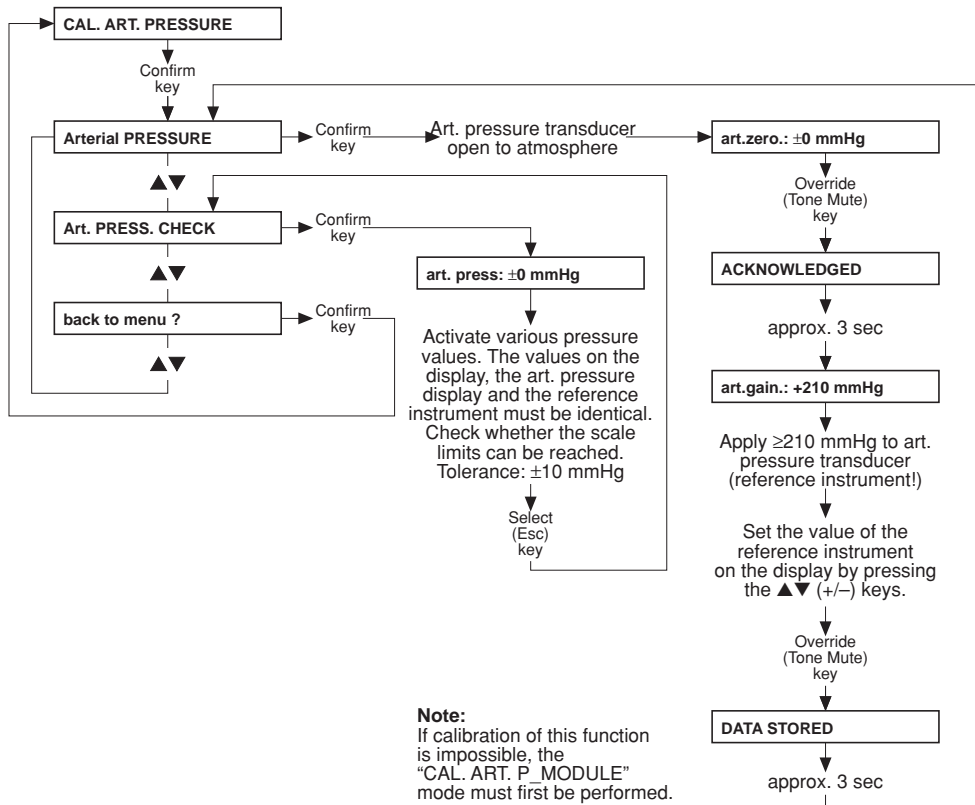

Note
Pressure gauge accuracy: ±1 % of the measured value.

- **Part 2: Calibrating the pressure in the arterial blood pump**

Set the hex switch in the module (P.C.B. LP 624, pos. 1) to position F.
 Should the error message E02 appear on the blood pump display, clear the message by pressing the **Start/Stop** key.

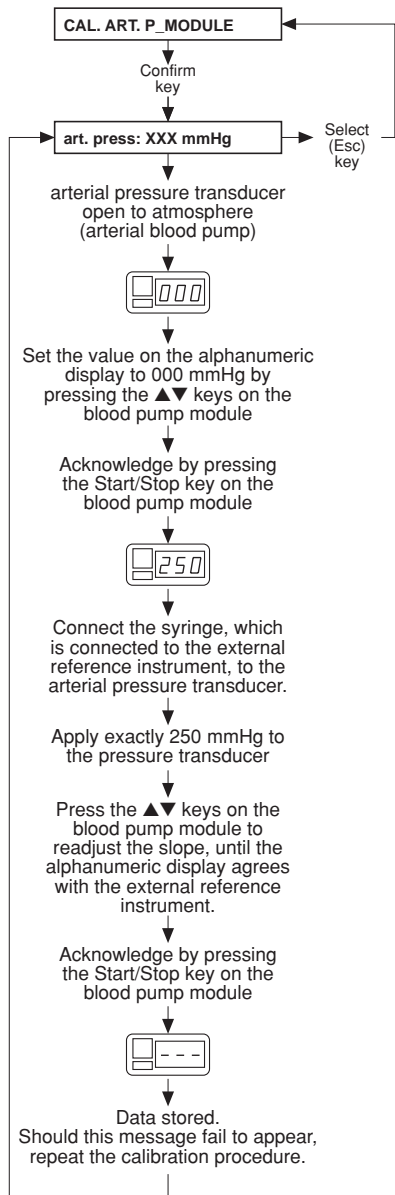

Return the hex switch to position 0.

- **Without display messages: adjusting the blood pump stop alarm (blood pump or HDF pump)**

Set the hex switch in the module (P.C.B. LP 624, pos. 1) to position B.
Should the error message E02 appear on the blood pump display, clear the message by pressing the **Start/Stop** key.

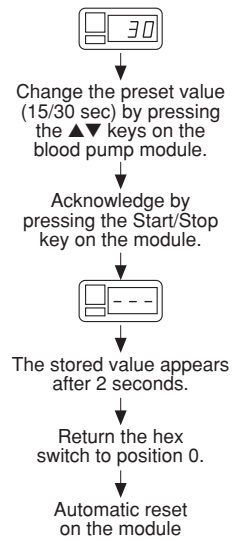

● Part 3: Calibrating the venous pressure

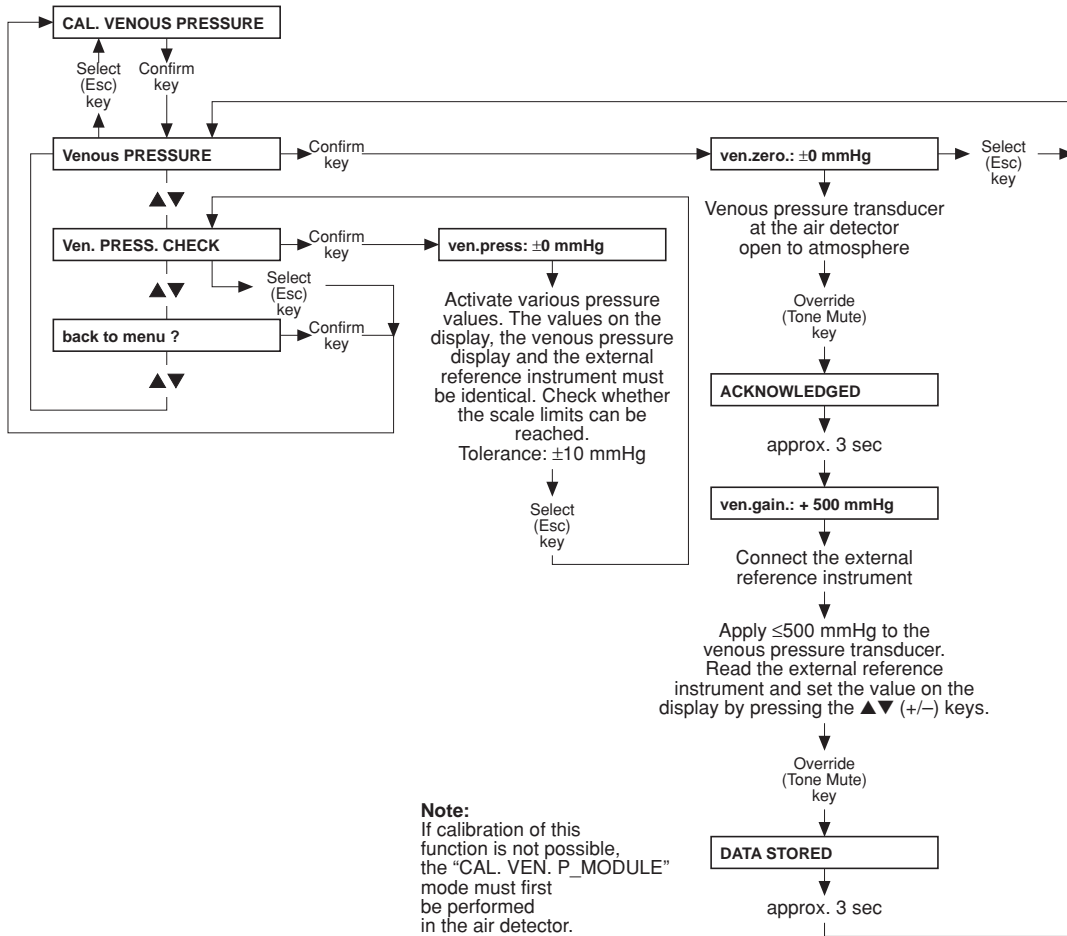

Note

Pressure gauge accuracy: ± 1 % of the measured value.

● **Part 4: Calibrating the venous pressure measurement in the air detector**

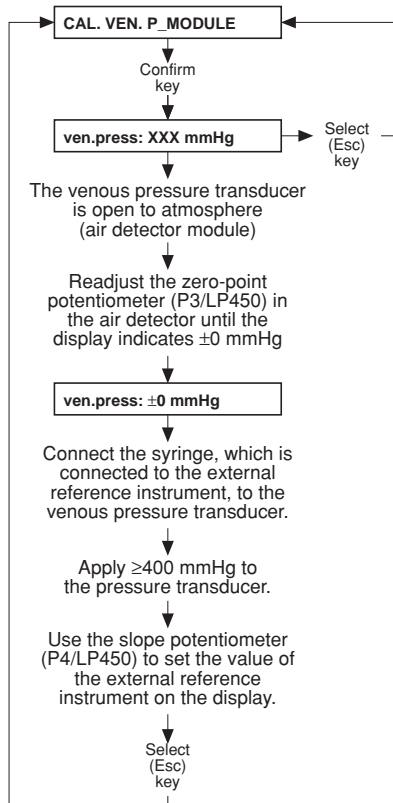

Note:
Check zero point and slope;
if necessary, repeat the procedure.

Note:
When adjusting the
air detector,
execute the
CAL. VENOUS PRESSURE
menu item.

LP 450

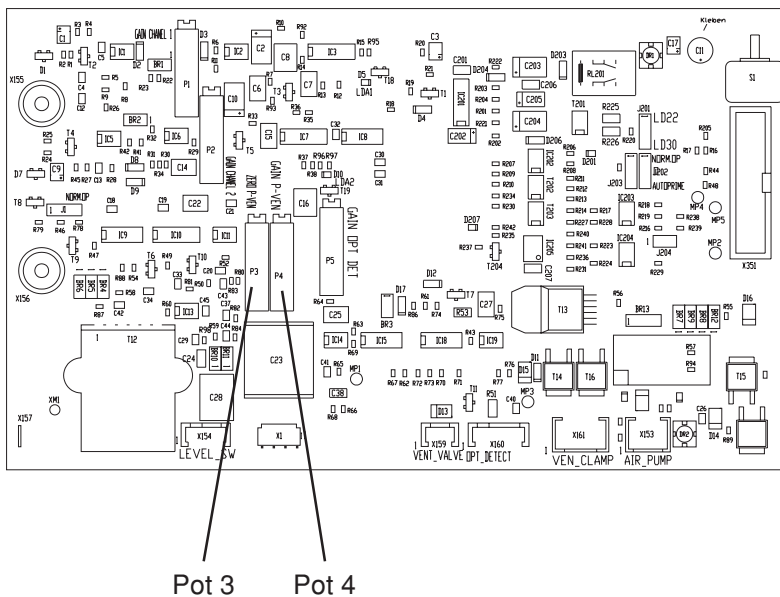

● **Part 5: Calibrating the blood pump rates**

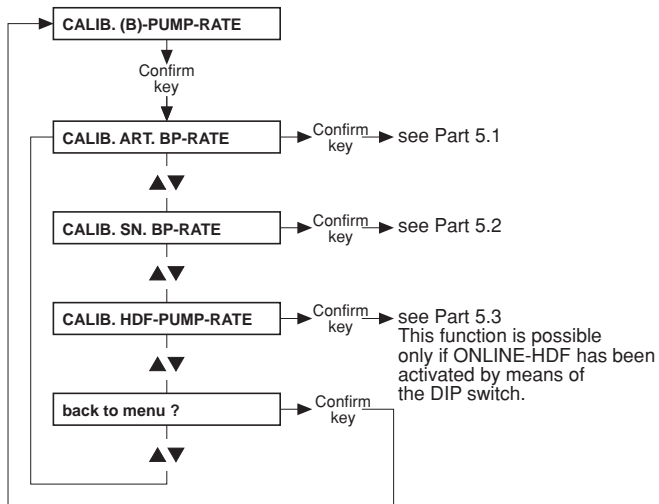

● **Part 5.1: Calibrating the arterial blood pump**

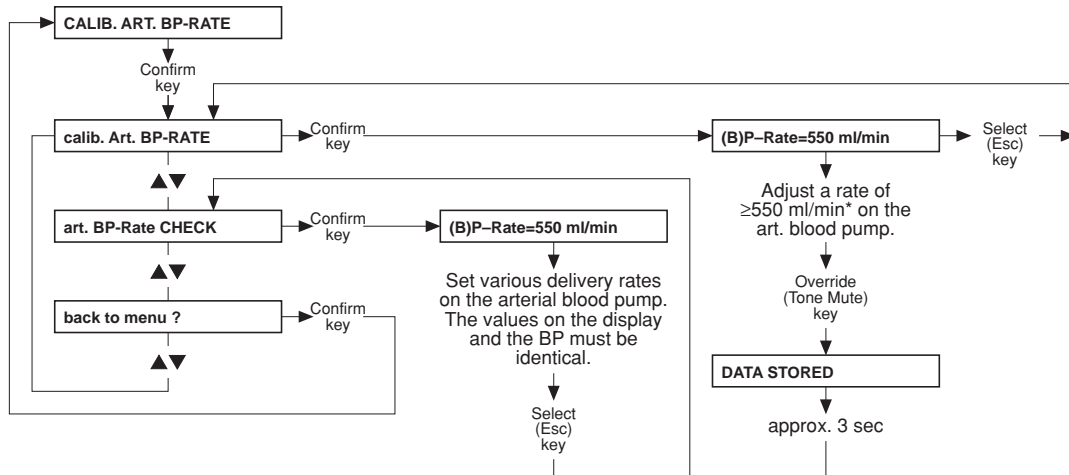

Note: Set the line diameter to 8 mm before starting the calibration procedure and press **Start/Stop** on the blood pump.

* The BP rate of 550 ml/min represents a default value. It can be changed using the ▲▼ (+/-) keys.

● **Part 5.2: Calibrating the Single-Needle blood pump rate**

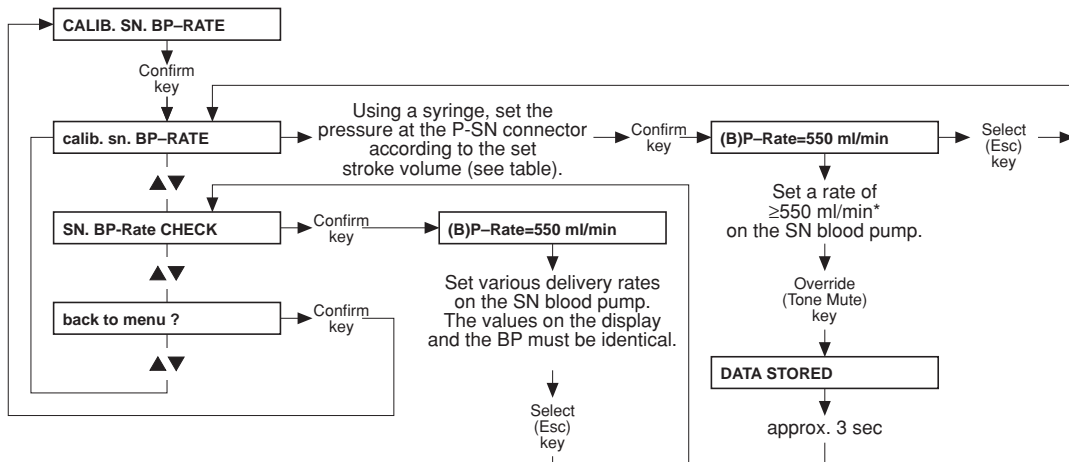

Note: Set the line diameter to 8 mm before starting the calibration procedure and press **Start/Stop** on the blood pump.

* The BP rate of 550 ml/min represents a default value. It can be changed using the ▲▼ (+/-) keys.

SN pump: lower switching point fixed to 75 mmHg

Stroke volume (ml)	10	15	20	25	30	35	40	45	50
Upper switching point (mmHg) ± 7 mmHg	110	130	150	172	195	219	244	270	299

● **Setting the Single-Needle stroke volume**

Press the ▼ and the **Start/Stop** key simultaneously.

Use the ▲ and ▼ keys to adjust the stroke volume and the **Start/Stop** key to confirm the value.

● **Part 5.3: Calibrating the ONLINE-HDF pump (option)**

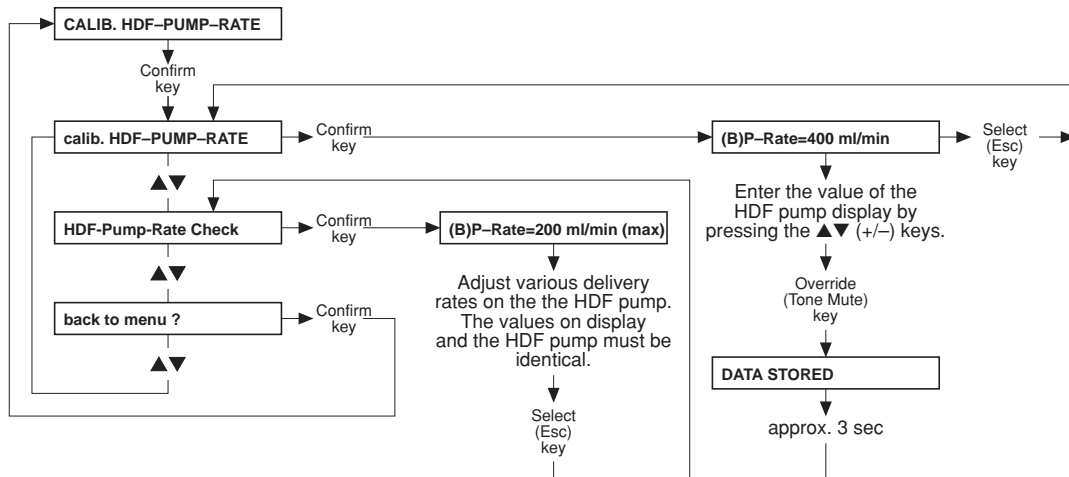

Note: This function is possible only if ONLINE-HDF has been activated by means of the DIP switch.

- **Without display messages: Calibrating the Single-Needle blood pump (SN pressure) (option)**

Set the hex switch in the module (P.C.B. LP 624, pos. 1) to position F.
Should the error message E02 appear on the blood pump display, clear the message by pressing the **Start/Stop** key.

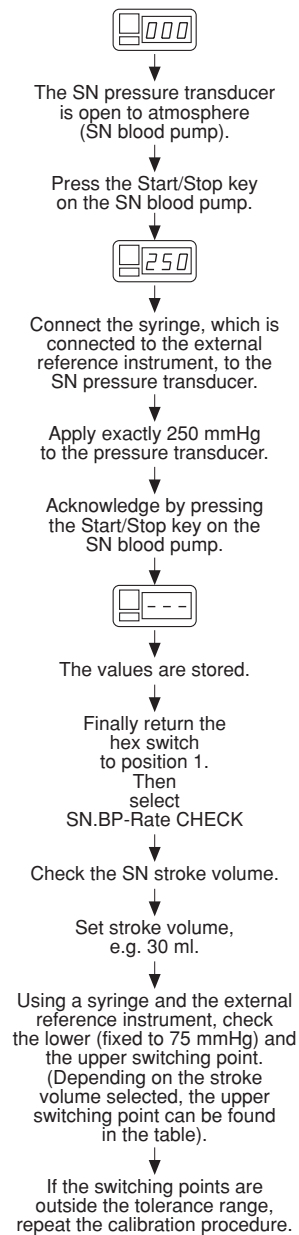

SN pump: lower switching point fixed to 75 mmHg

Stroke volume (ml)	10	15	20	25	30	35	40	45	50
Upper switching point (mmHg) \pm 7 mmHg	110	130	150	172	195	219	244	270	299



Note

It may be necessary to change the Single-Needle stroke volume:
Press the ▼ and the **Start/Stop** key simultaneously.
Use the ▲ and ▼ keys to adjust the stroke volume and the **Start/Stop** key to confirm the value.

● Part 6: Adjusting the UF pump volume

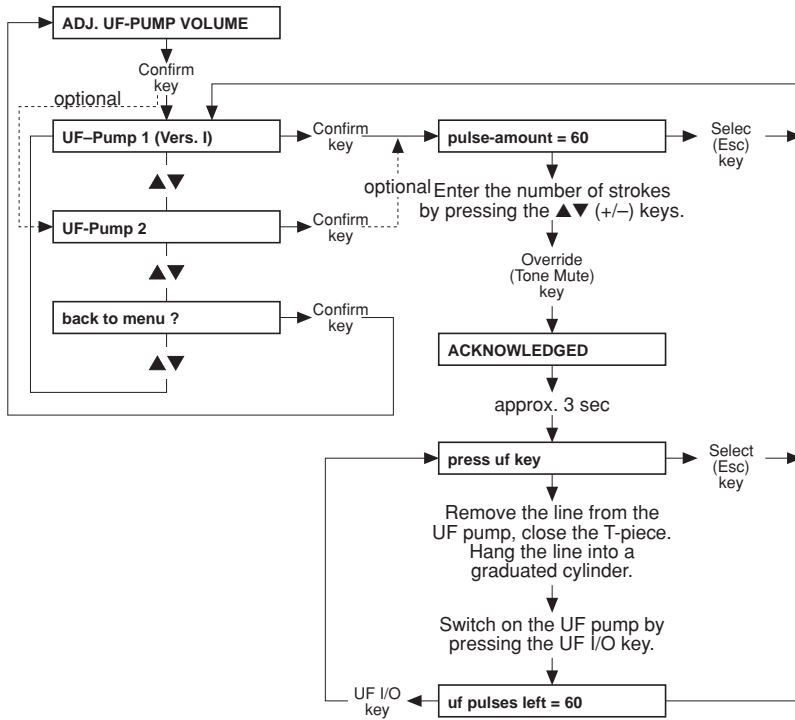

Note:
Check the volume.
If necessary, readjust the UF pump
and repeat the procedure.
(See 3.3.5)

The remaining UF strokes are
indicated on the display.
The "UF Goal" display
indicates the number of
preselected strokes.



Note

Graduated cylinder accuracy: $\pm 0.5\%$.



Note

If a scale is used as measurement instrument it must be ensured that no concentrate is connected.

● **Part 7: Calibrating the degassing pressure**

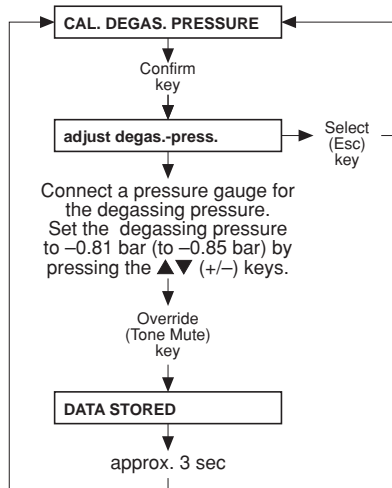

At this point, the following messages may appear:

- fill program active
- set flow on

See also 3.3.2 Degassing pump pressure

● **Part 8: 300 ml/min flow**

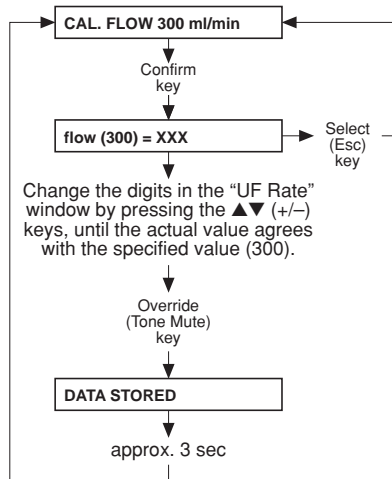

Important:

If it is impossible to adjust the 300 – 500 – 800 flow volumes, or if problems caused by flow alarms occur after the “calibrate flow” message has appeared, this can be caused by the setting of the current rise pulse.

Note:

(only for systems with advanced hydraulics)

For the flow selected first, the message “DIASAFE-filling act.” is displayed for 17 balancing chamber switchings.

Adjusting the current rise pulse:

- Select “**CAL.FLOW 300 ml/min**”; display: flow (300) = XXX.
- The actual flow XXX must be approx. 300; if necessary, correct it using the ▲ and ▼ keys.
- Connect an oscilloscope to MP8 and MP1, and the ground MP7 to P.C.B. LP 634.
- Use P1 to set the current rise pulse as shown in the diagram below. Make sure that the actual flow (display XXX) remains at approx. 300; if necessary, correct it using the ▲ and ▼ keys.

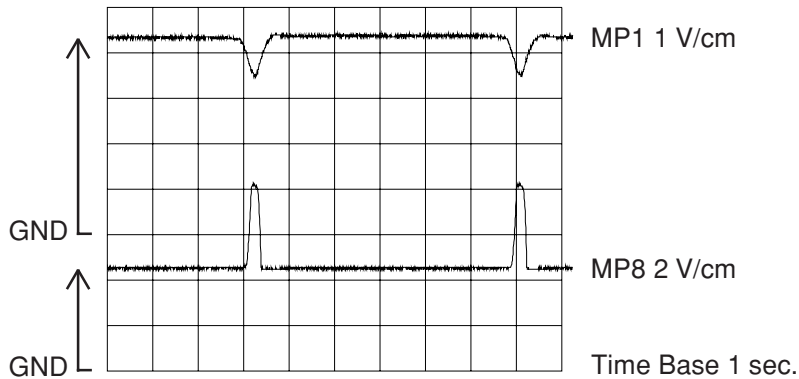

Alternative adjustment of the current rise (if an oscilloscope is not available):

- Select “calibrate flow 300 ml/min”.
- There are two possibilities of reaction by the system:
 1. The system runs with regular balancing chamber switching.
Display: flow (300) = XXX.
 - If necessary, correct the flow using the ▲ and ▲ keys, until the actual flow indicates approx. 300.
 - Turn the potentiometer P1 counter-clockwise (wait for at least 10 sec after each rotation!), until the system switches to “Eigentakt”.
 - Display: flow (300) = 147.
 - Now turn the potentiometer P1 clockwise (wait for at least 10 sec after each half-rotation!), until the actual flow again indicates approx. 300.
 - Turn the potentiometer P1 clockwise for another 2 rotations.
 2. The system is in the “Eigentakt” mode.
Display: flow (300) = 147.
 - Turn the potentiometer P1 clockwise, until the system switches from “Eigentakt” to regular balancing chamber switching (wait for approx. 10 sec after each rotation!).
 - Display: flow (300) = XXX.
 - If necessary, correct the flow using the ▲ and ▲ keys, until the actual flow indicates approx. 300.
 - Turn the potentiometer P1 counter-clockwise (wait for at least 10 sec after each rotation), until the system switches to “Eigentakt”.
 - Display: flow (300) = 147.
 - Now turn the potentiometer P1 clockwise (wait for at least 10 sec after each half-rotation!), until the actual flow again indicates approx. 300.
 - Turn the potentiometer P1 clockwise for another 2 rotations.

After adjusting the current rise pulse, check and, if necessary, readjust the 300/500/800 flow settings.

● **Part 9: Calibrating the 500 ml/min flow**

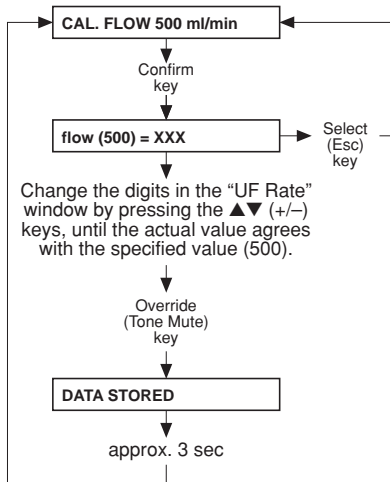

● **Part 10: 800 ml/min flow**

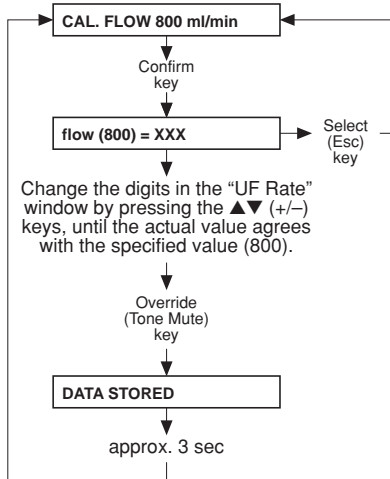

● **Part 11: Calibrating the dialysate temperature**

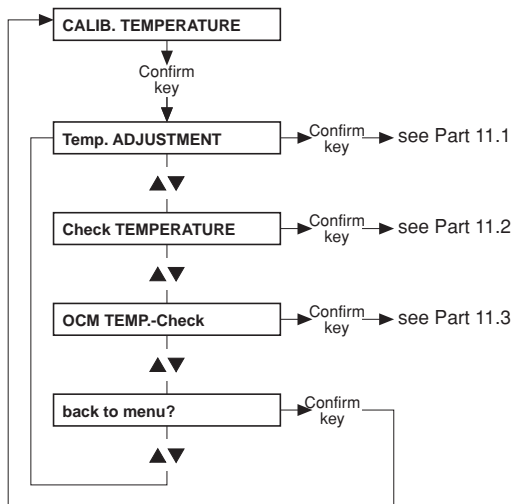

Note

Accuracy of the measuring instrument to be connected externally: ± 0.2 °C.

● Part 11.1: Adjusting the dialysate temperature

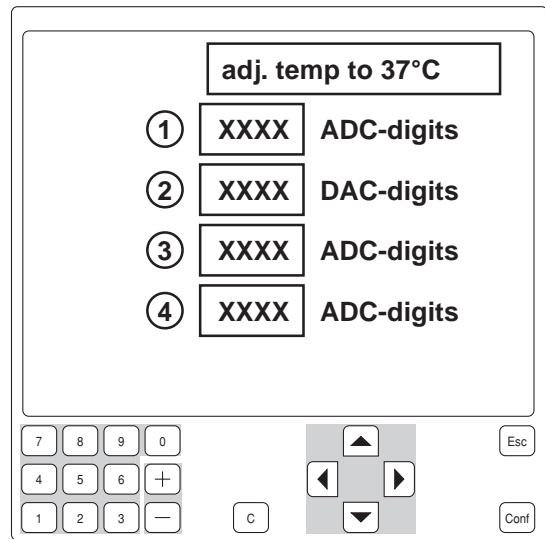
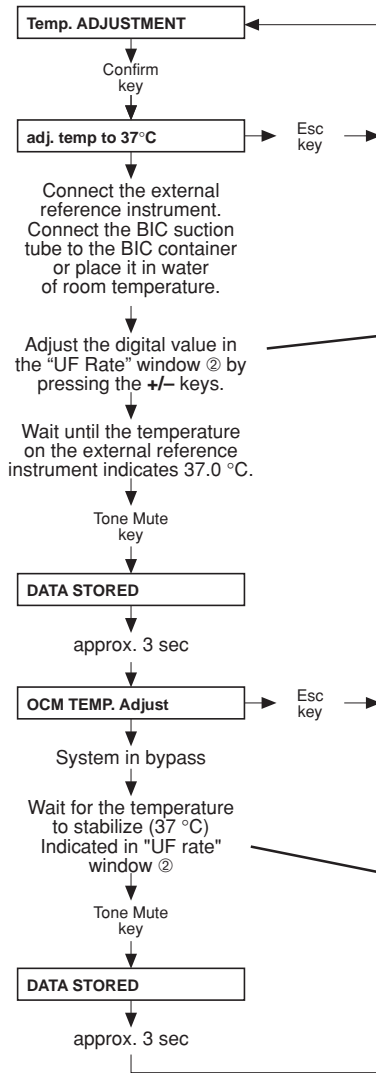

- ① NTC3; 8 bit
- ② Control 8 bit
- ③ NTC3; 12 bit (with OCM option only)
- ④ NTC109; 8 bit, if NTC 109 is activated in SETUP

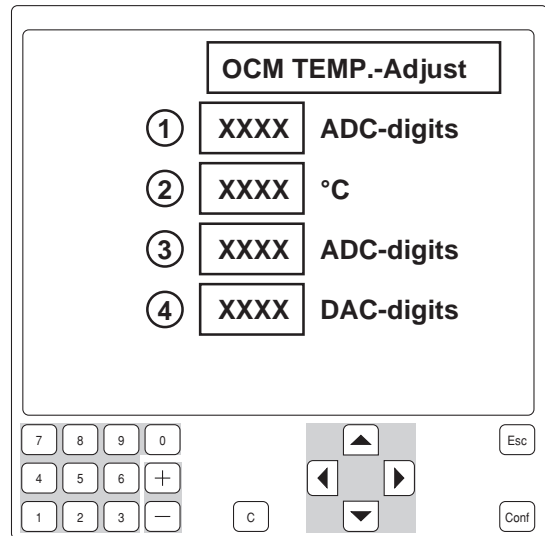

- ① NTC3; 8 bit (with OCM option: 12 bit)
- ② NTC3 temperature
- ③ NTC4; 12 bit (with OCM option only)
- ④ Dynamic measurement range switching

● Part 11.2: Checking the dialysate temperature

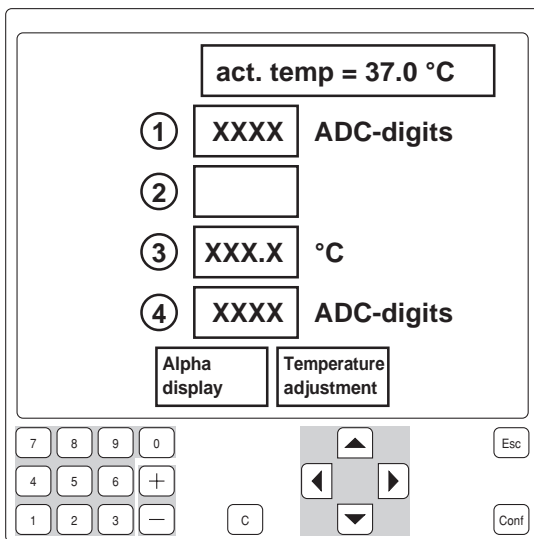
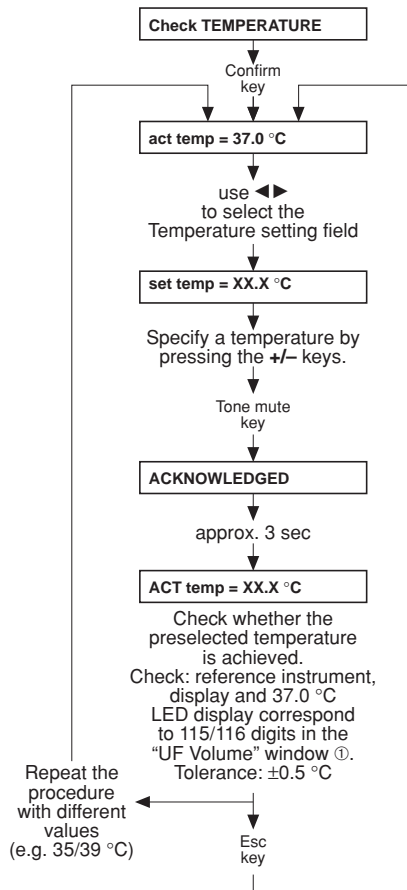

- ① NTC3; 8 bit
- ②
- ③ NTC109; temperature
- ④ NTC109; 8 bit

● Part 11.3: Checking the dialysate temperature for the OCM option

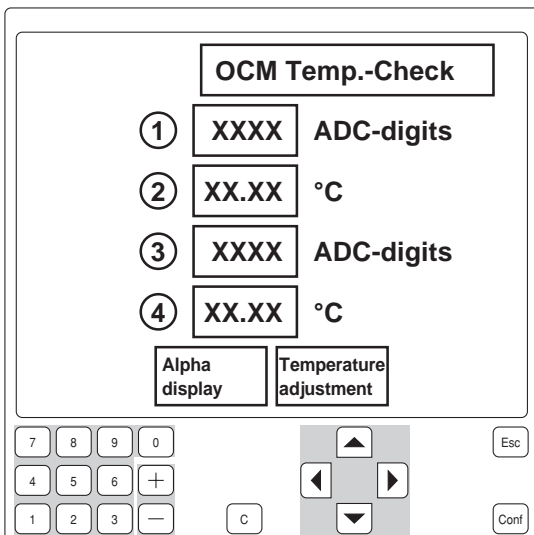
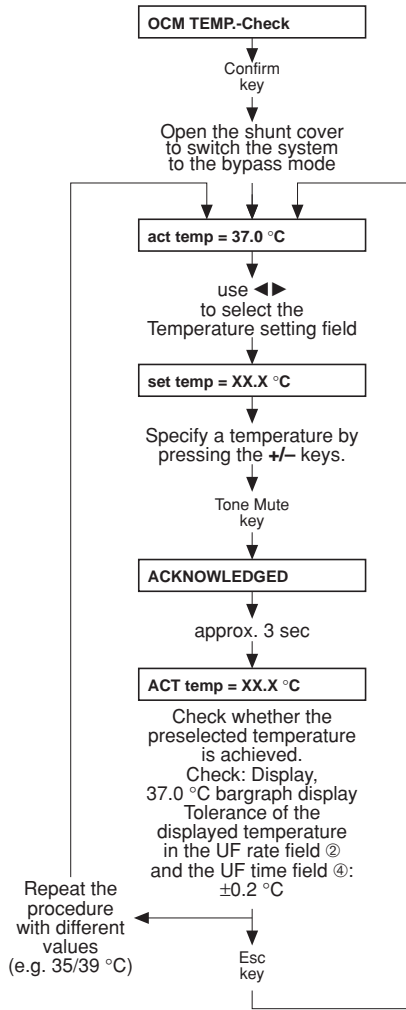

- ① NTC3; 12 bit
- ② NTC3; temperature
- ③ NTC4; 12 bit
- ④ NTC4; temperature

● **Part 12: Calibrating the mixing system**

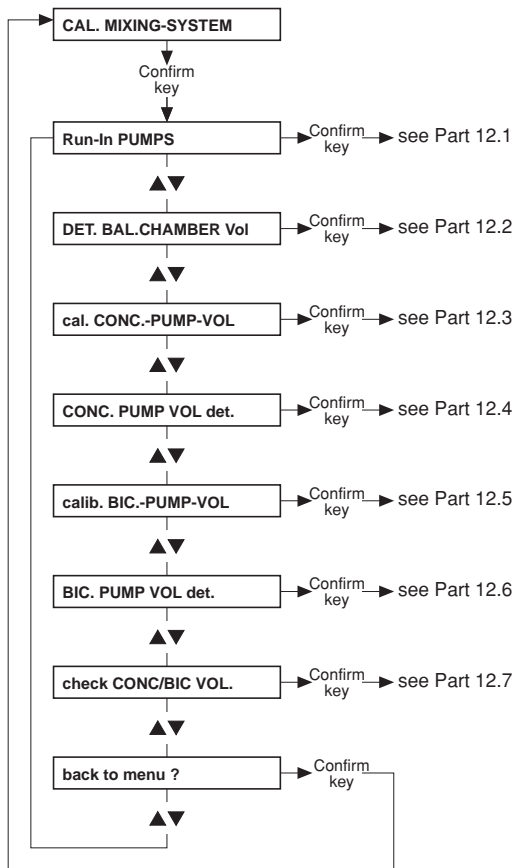

● **Part 12.1: Running-in of the membrane pumps**

The membrane pumps have to run-in so that the concentrate/bicarbonate pumps reach their operating temperatures before the pump volume is verified.

The concentrate suction tubes are in a container filled with water

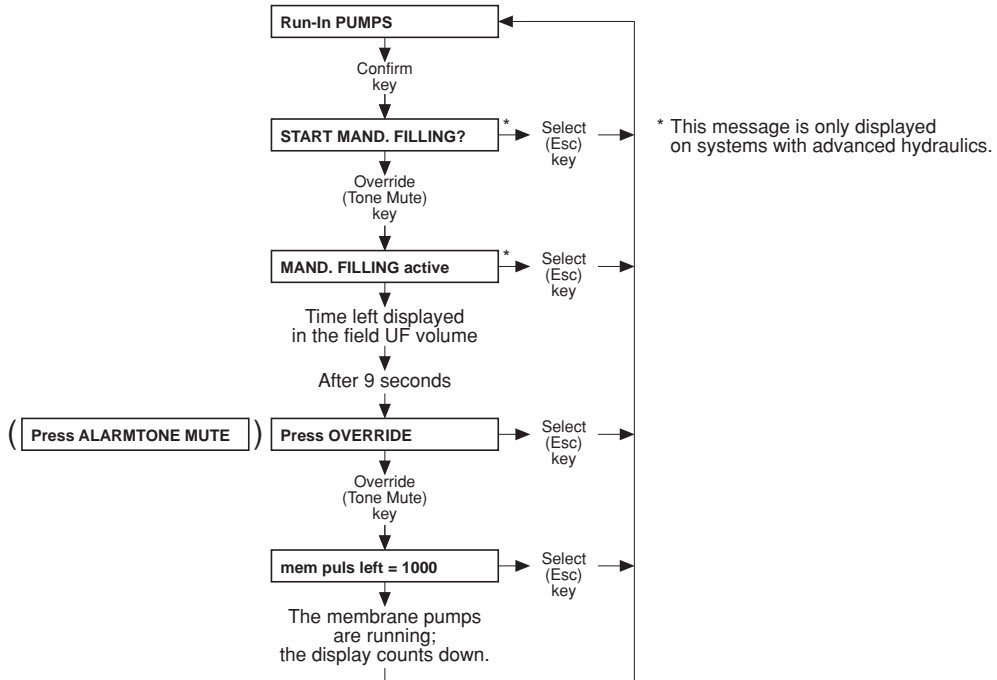

● Part 12.2: Determining the balancing chamber volume

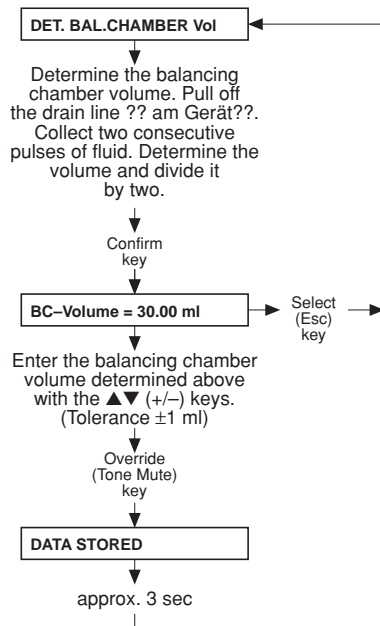

Note

Accuracy of the measuring cylinder: $\pm 0.5\%$.



Note

If a scale is used as measurement instrument it must be ensured that no concentrate is connected.

● Part 12.3: Calibrating the concentrate pump stroke

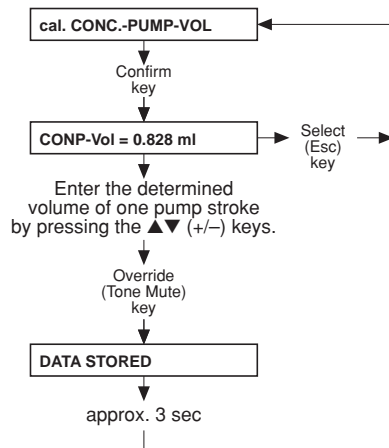

Note

Accuracy of the measuring cylinder: $\pm 0.5\%$.

● Part 12.4: Determining the concentrate pump volume

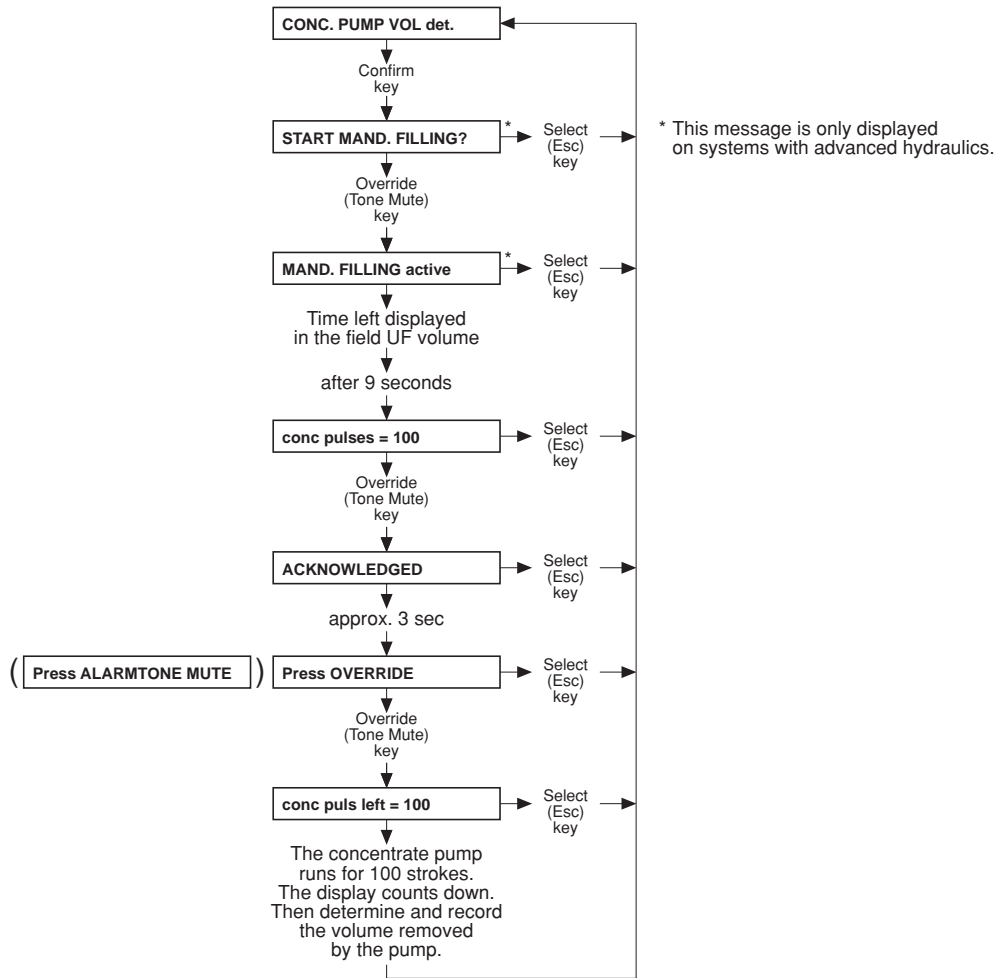

Notes:

100 strokes are factory-set. This setting can be changed by pressing the ▲▼ (+/-) keys (depending on the graduated cylinder used). However, when returning to "CAL. MIXING-SYSTEM", the display will indicate the factory setting again.

Check the volume and, if necessary, repeat the procedure.



Note

Accuracy of the measuring cylinder: ±0.5 %.



Note

If a scale is used as measurement instrument it must be ensured that no concentrate is connected.

● Part 12.5: Calibrating the bicarbonate pump stroke

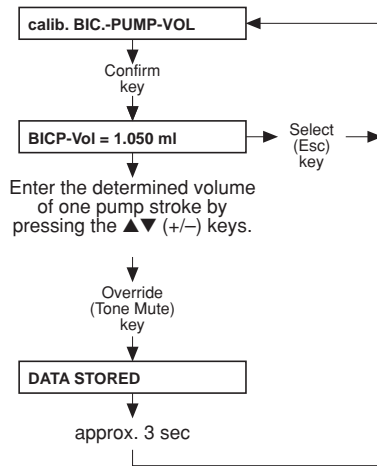

Note

Accuracy of the measuring cylinder: $\pm 0.5\%$.



Note

If a scale is used as measurement instrument it must be ensured that no concentrate is connected.

● Part 12.6: Determining the bicarbonate pump volume

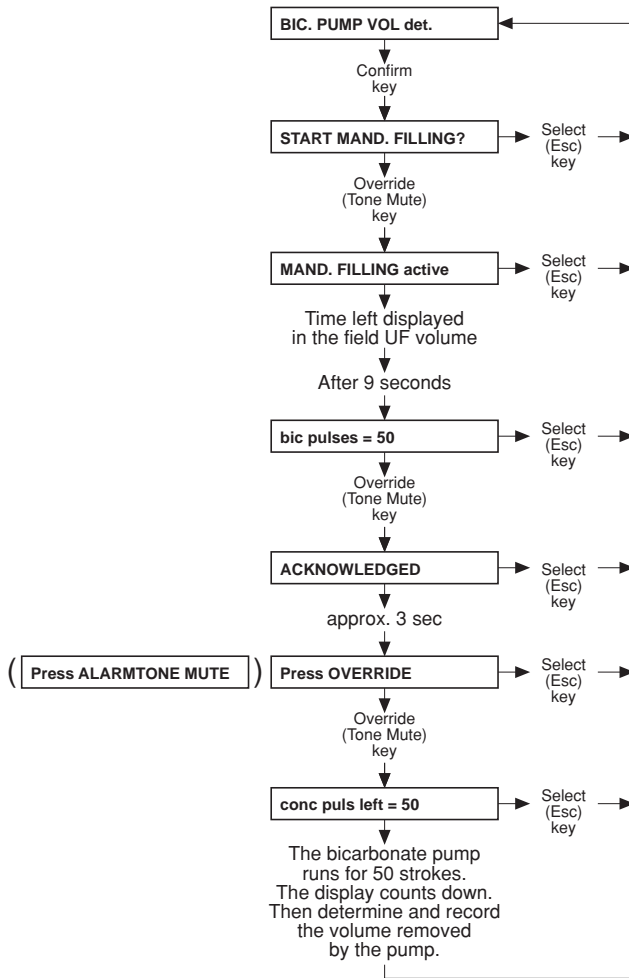

Notes:

50 strokes are factory-set. This setting can be changed by pressing the ▲▼ (+/-) keys (depending on the graduated cylinder used). However, when returning to "CAL. MIXING-SYSTEM", the display will indicate the factory setting again.

Check the volume and, if necessary, repeat the procedure.



Note

Accuracy of the measuring cylinder: ±0.5 %.



Note

If a scale is used as measurement instrument it must be ensured that no concentrate is connected.

● Part 12.7: Checking the concentrate and/or bicarbonate volume

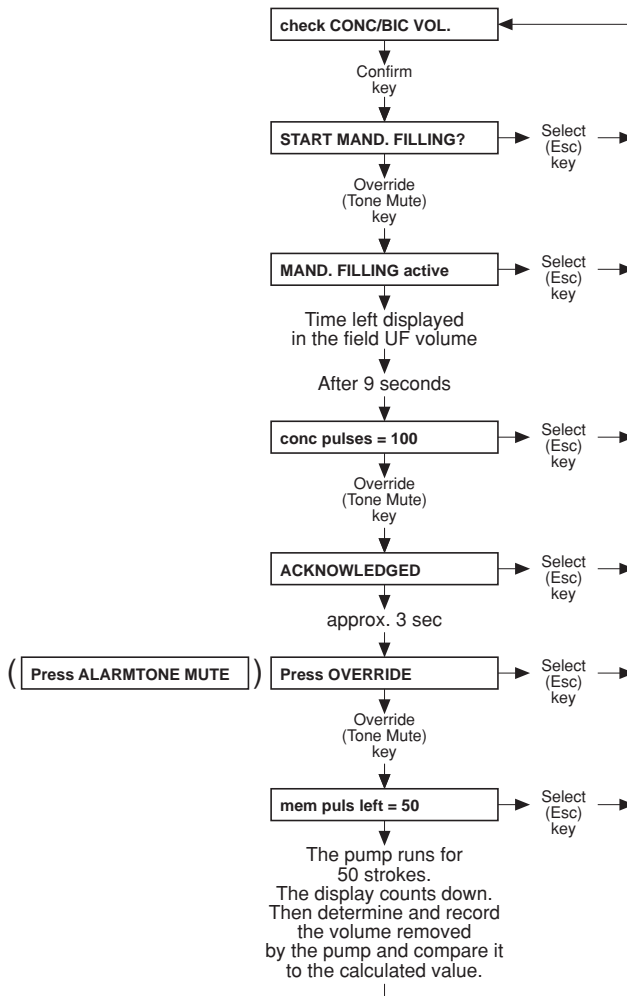

Check mixing ratio

Notes:

This test step permits verification of the concentrate or bicarbonate pump volumes in accordance with the parameters entered for the mixing system (mixing ratio, BC volume, conc. and bic. pump volume).

The pump whose concentrate suction tube is pulled off is activated.

50 strokes are factory-set. This setting can be changed by pressing the ▲▼ (+/-) keys (depending on the graduated cylinder used). However, when returning to "CAL. MIXING-SYSTEM", the display will indicate the factory setting again.



Note

Accuracy of the measuring cylinder: ±0.5 %.



Note

If a scale is used as measurement instrument it must be ensured that no concentrate is connected.

● **Part 13: Calibrating the conductivity**

The indicated values are examples

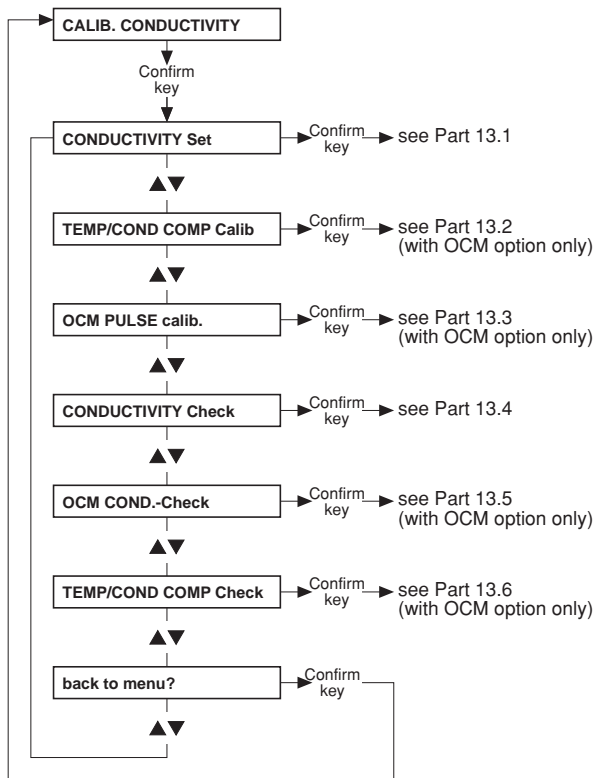

● Part 13.1: Setting the conductivity

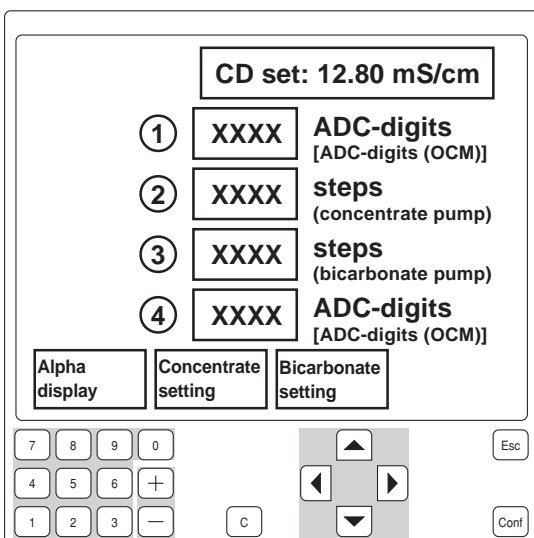
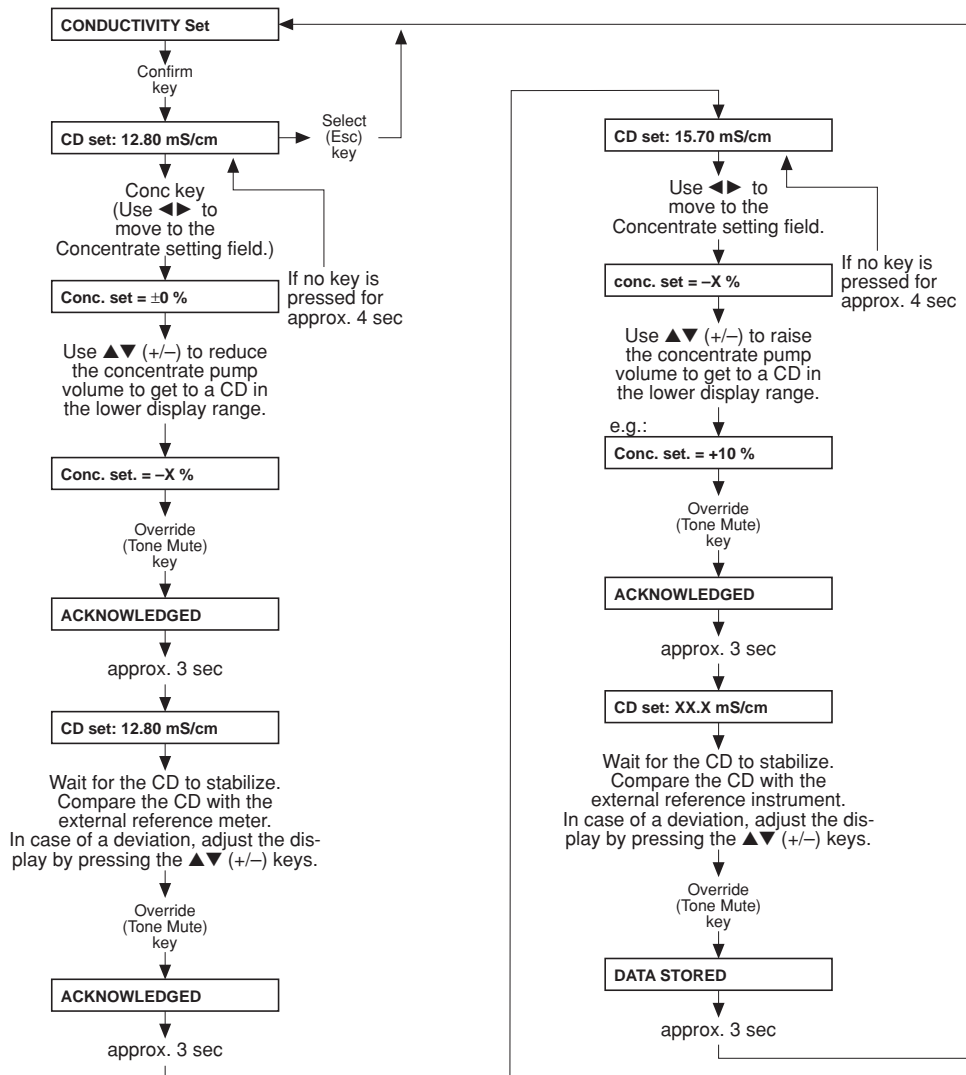

- ① CD cell 7; 12 bit / 8 bit alternating (with OCM option only)
- ②
- ③
- ④ CD cell 110; 12 bit/ 8 bit alternating (with OCM option only)

● Part 13.2: Setting the temperature/conductivity compensation (with OCM option only)

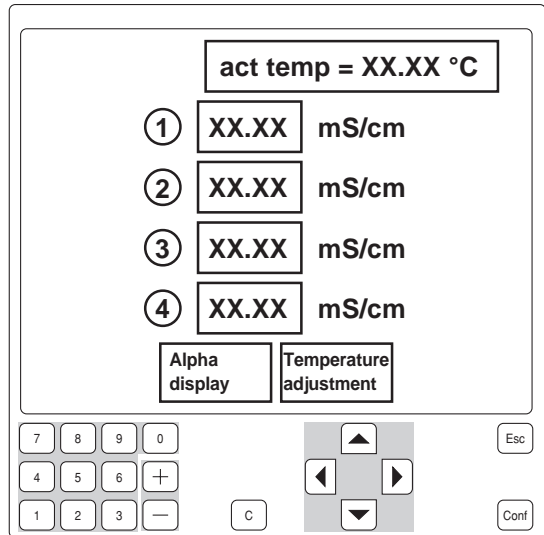
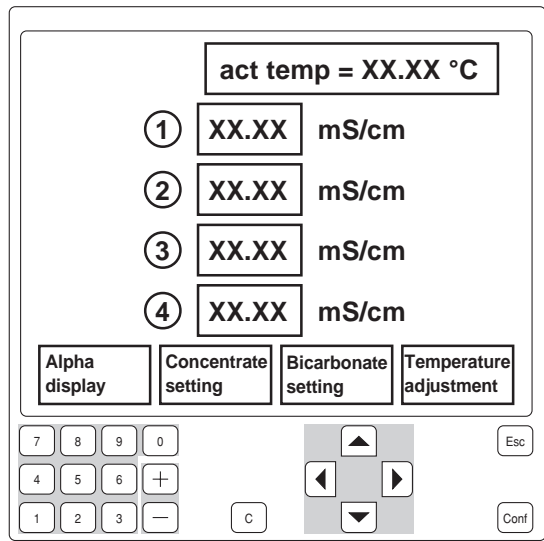
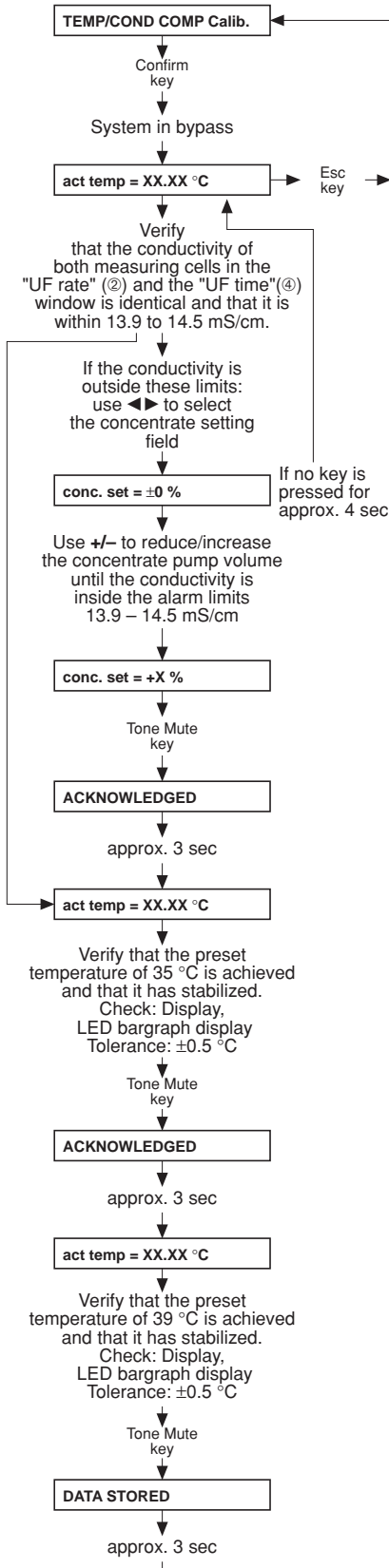

- ① CD cell 7, Value in mS/cm after confirmation of 35°C
- ② CD cell 7, current value in mS/cm
- ③ CD cell 110, Value in mS/cm after confirmation of 35°C
- ④ CD cell 110, current value in mS/cm

● Part 13.3: Calibrating the OCM pulse (with OCM option only)

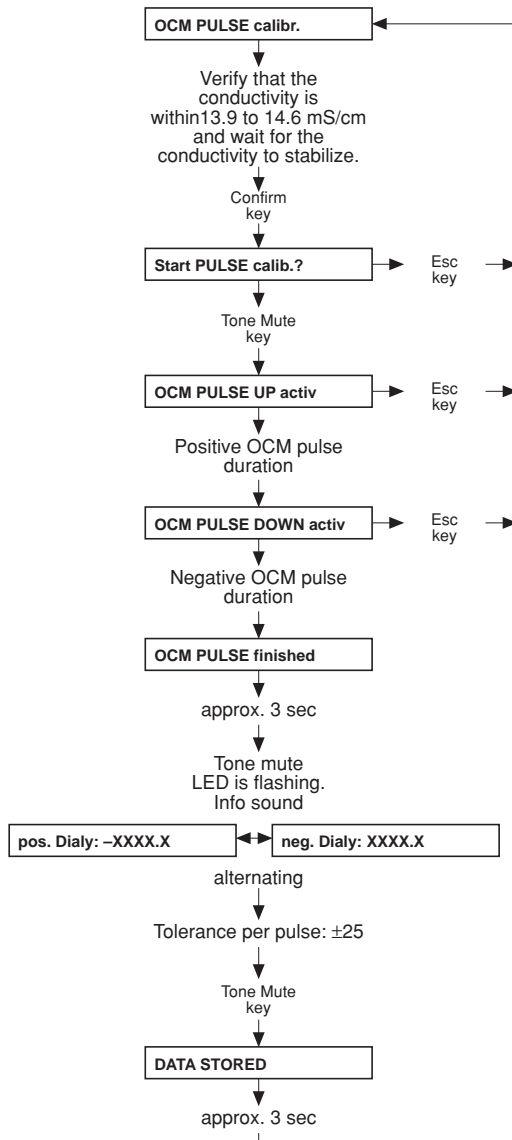

Note
If the value is outside ± 25 , check the conductivity measuring system of the dialysis system.

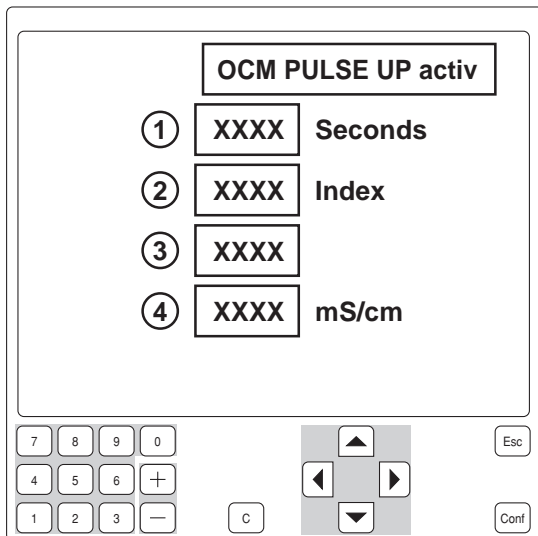

- ① Time elapsed since the pulse calibration was started
- ② Counter
- ③ Concentrate setting
- ④ CD cell 7, compensated CD value

● Part 13.4: Checking the conductivity

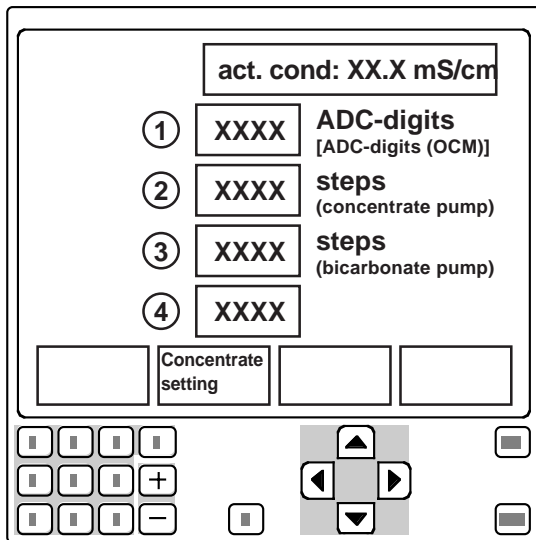
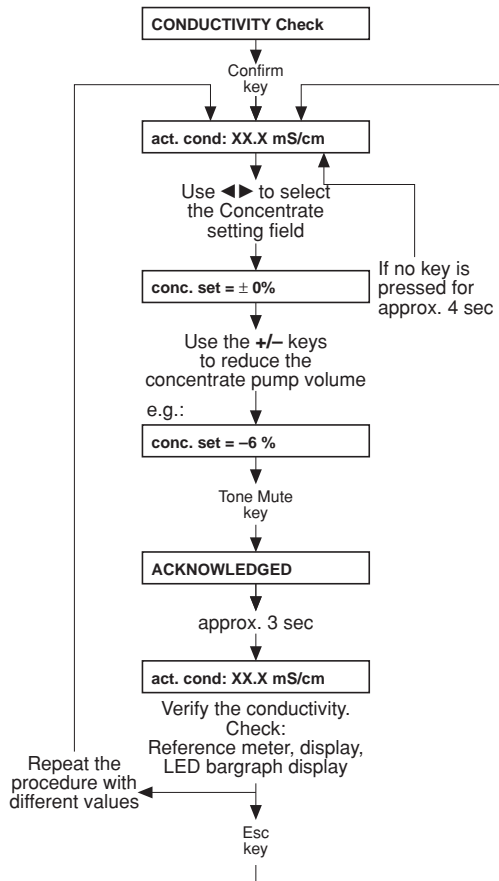

- ① CD cell 7;
12 bit / 8 bit
alternating
(with OCM option only)
- ②
- ③
- ④ CD cell 110;
12 bit / 8 bit
alternating
(with OCM option only)

● Part 13.5: Checking the OCM conductivity (with OCM option only)

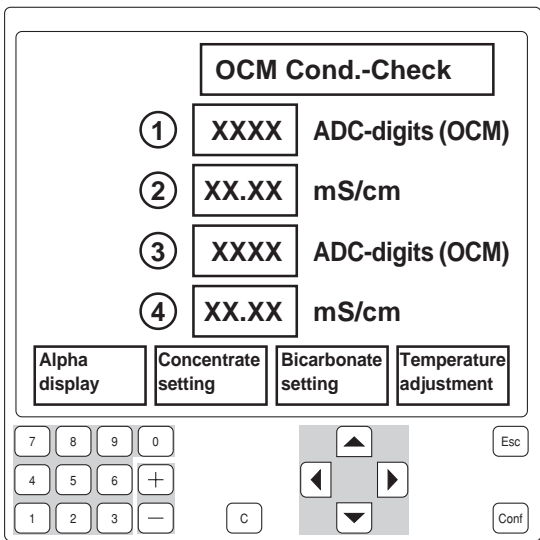
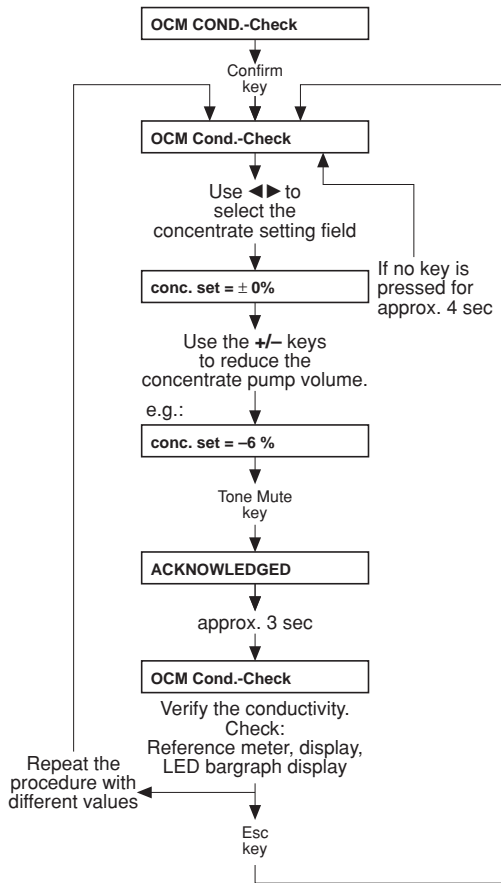

- ① CD cell 7; 12 bit
- ② CD cell 7
- ③ CD cell 110;12 bit
- ④ CD cell 110

● Part 13.6: Temperature/conductivity compensation test (with OCM option only)

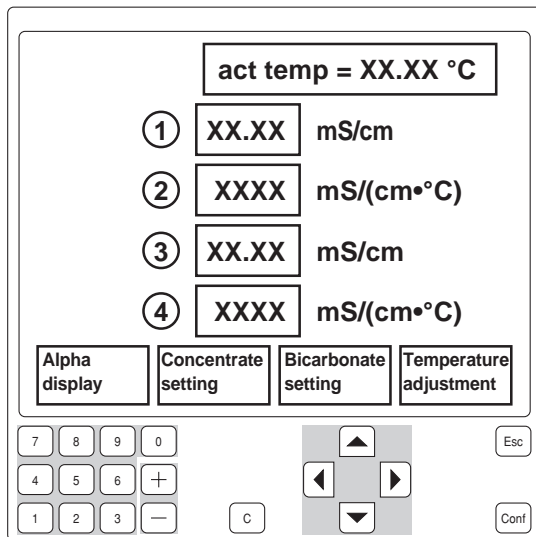
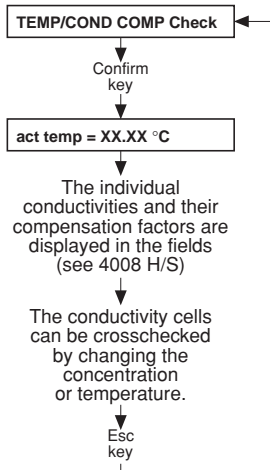

- ① CD cell 7, compensated
- ② CD cell 7, compensation factor
- ③ CD cell 110, compensated
- ④ CD cell 110, compensation factor

● **Part 14: Calibrating the dialysate pressure (stainless steel pressure transducer)**

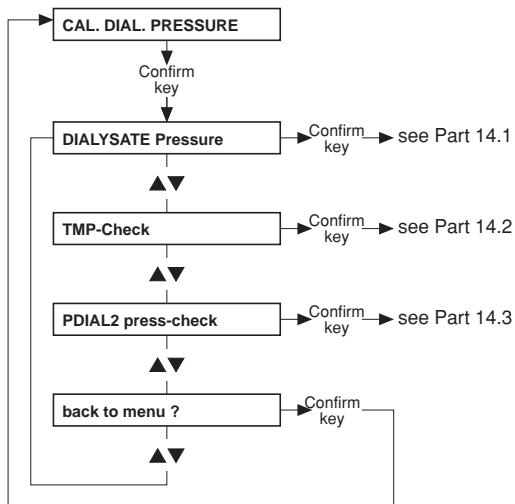

Note

Measuring instrument accuracy: $\pm 1\%$ of the measured value.

● Part 14.1: Dialysate pressure

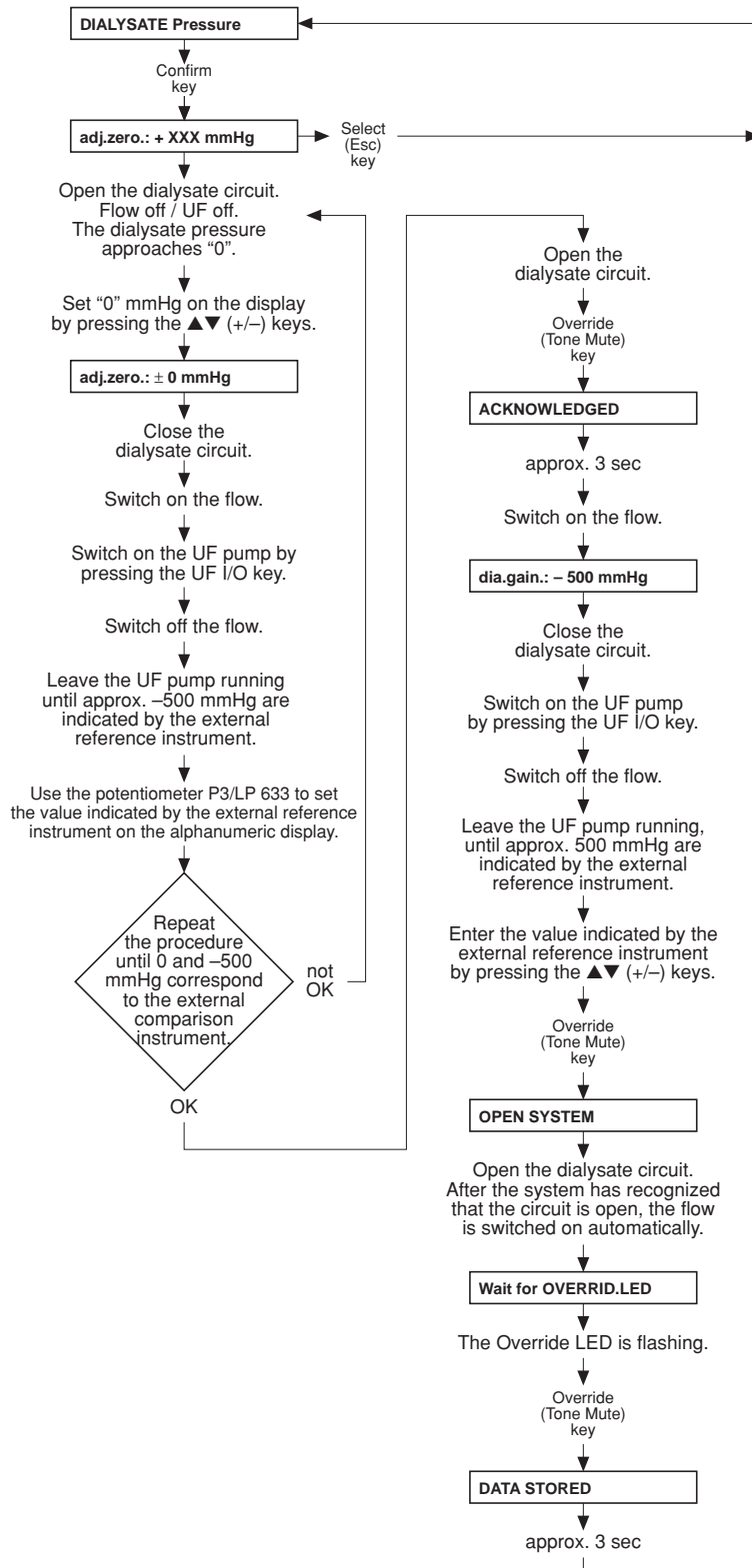

● **Part 14.2: TMP check**

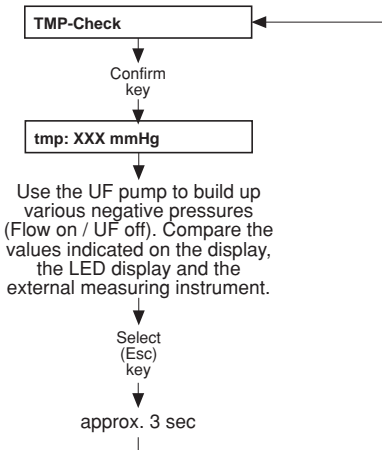

Note:
Observe the venous pressure!

Note:
Switch the flow on and off again once in a while, to maintain the operating temperature of the pressure transducer.

● **Part 14.3: PDIAL2 pressure check (for systems with advanced hydraulics only)**

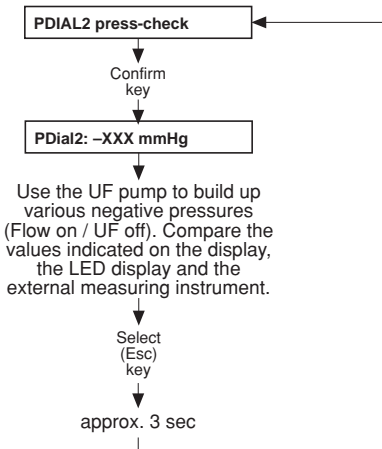

Note:
Observe the venous pressure!

4008 H/S:

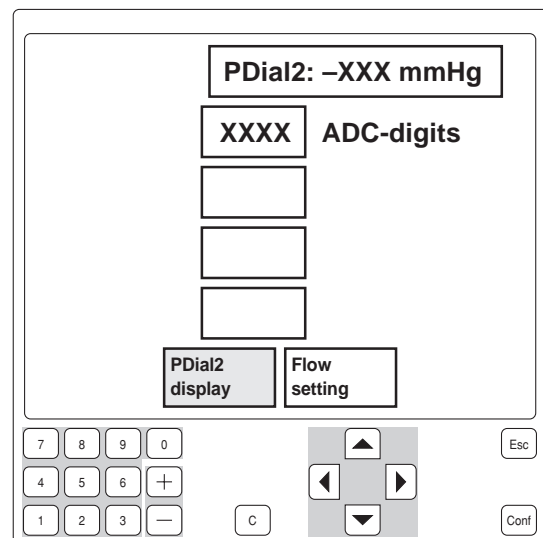

In 4008 H/S systems the temperature compensation function can also be checked: Press ◀▶ to select the field **Flow setting**. Adjust the flow by pressing +/- . Confirm by pressing the **Tone Mute** key.

● Part 15: Blood leak voltage

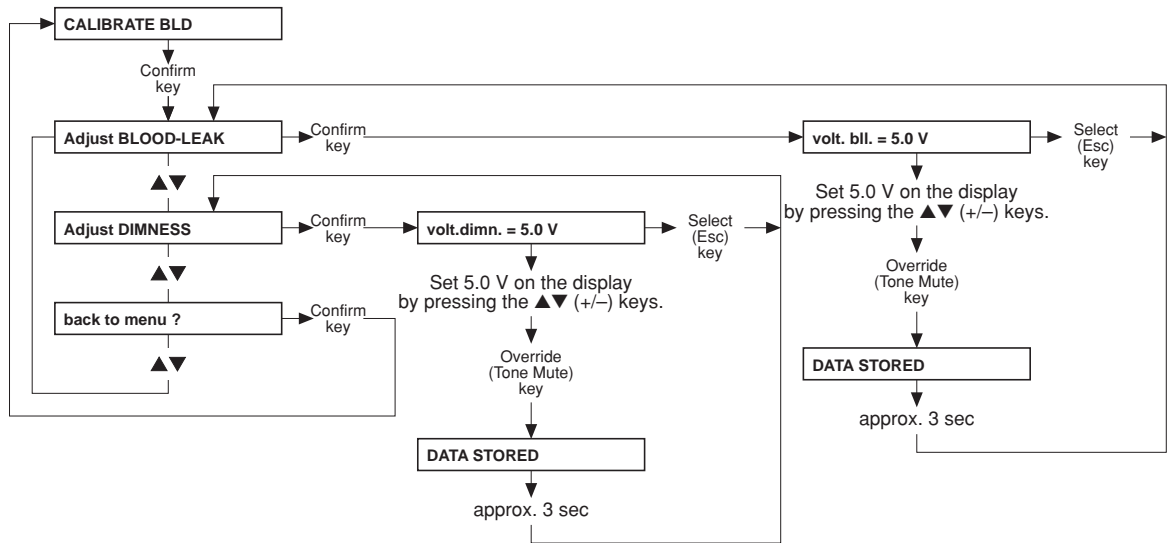

Tolerance for dimness voltage: 5 V ± 0.3 V.

Note: If values deviate check the glass burette for contamination.
Close the housing; temperature 37 °C; avoid incident light from an external source.

● Part 16: Calibrating the BIBAG values (optional)

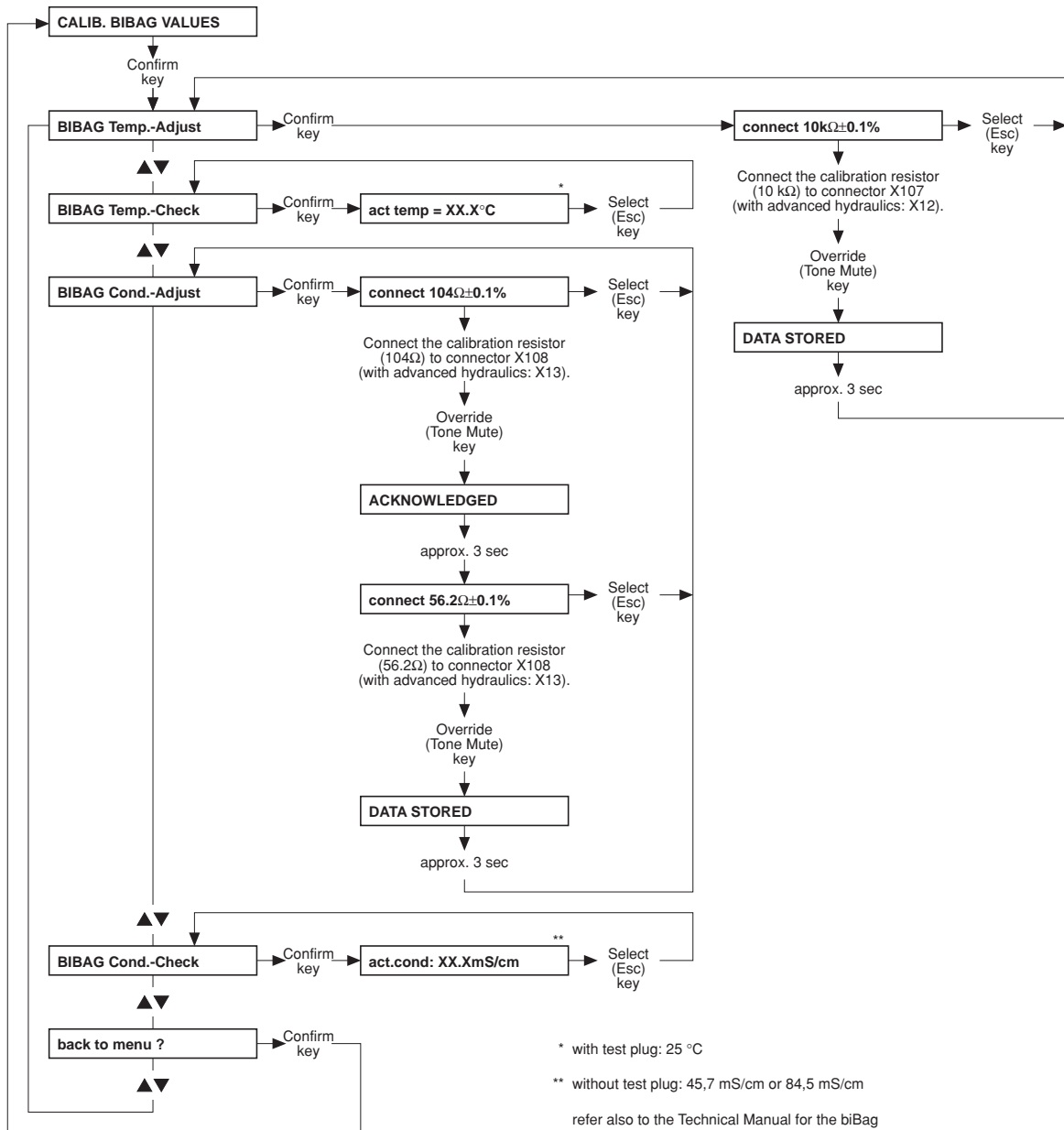

- **Part 17: Resetting the failure record**

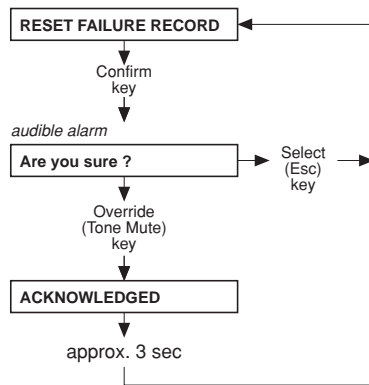

- **Part 18: Initializing the NOVRAM, resetting the mandatory rinse, resetting the V84 malfunction**

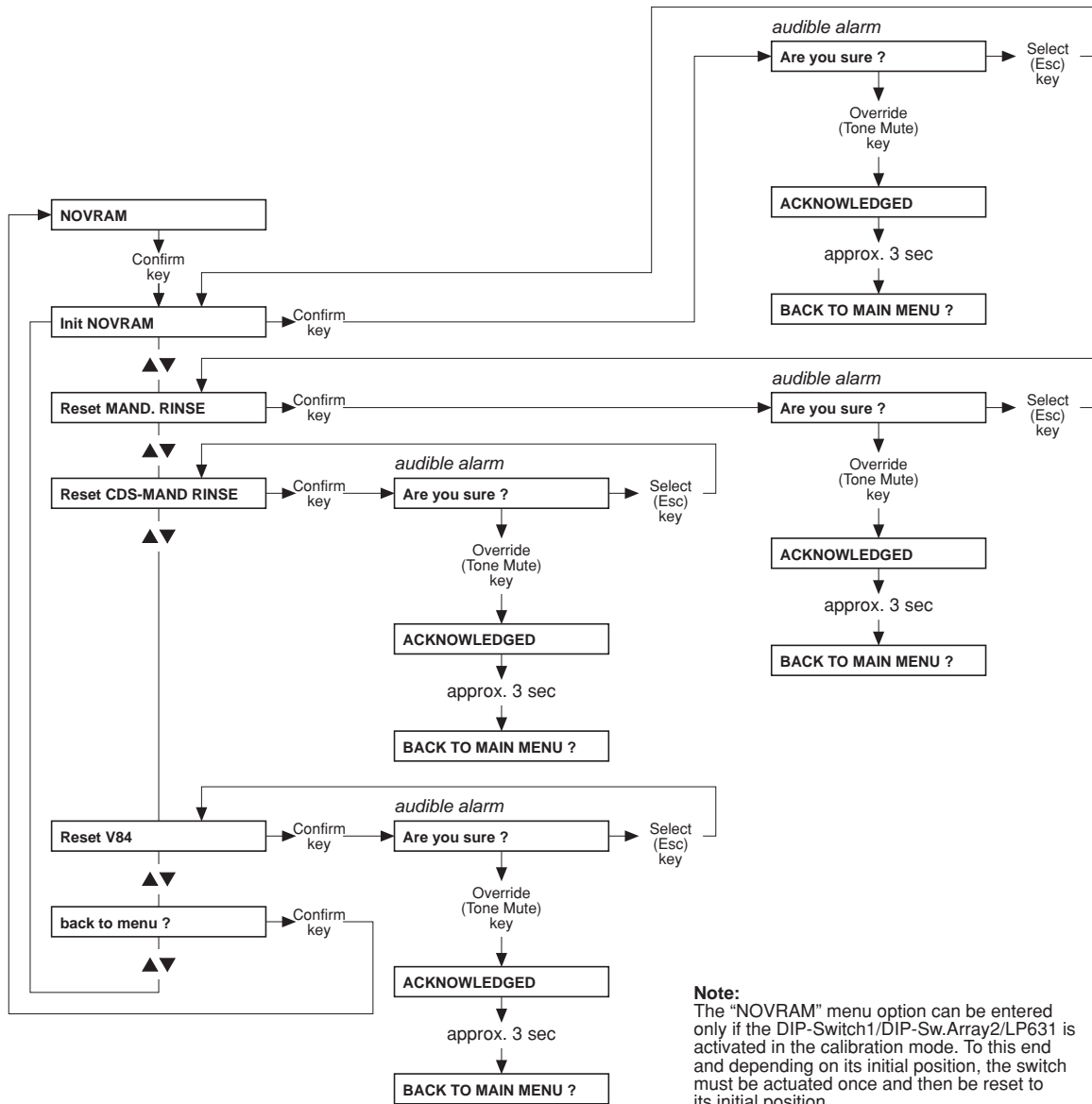

- **Without menu display: Adjusting the Hall sensor in the heparin pump**

Adjustment of Hall sensor 1

- Remove plug connector from Hall sensor 2.
- Move the slide carriage down over Hall sensor 1.
- Move the slide carriage up to its fully open position.
- Move the slide carriage down again to the end of its travel.
- The free motion between the slide carriage and the housing should be approx. 0.5 mm. If necessary, change the position of Hall sensor 1 and repeat the procedure.

Adjustment of Hall sensor 2

- Reconnect plug connector for Hall sensor 2.
- Move the slide carriage down to approx. 2 cm before the end of its travel.
- Manually turn the threaded spindle approx. 2-3 rotations in delivery direction.
- Move the slide carriage down.
- The slide carriage must stop before the mechanical end of its travel. If necessary, change the position of Hall sensor 2 and repeat the procedure several times.

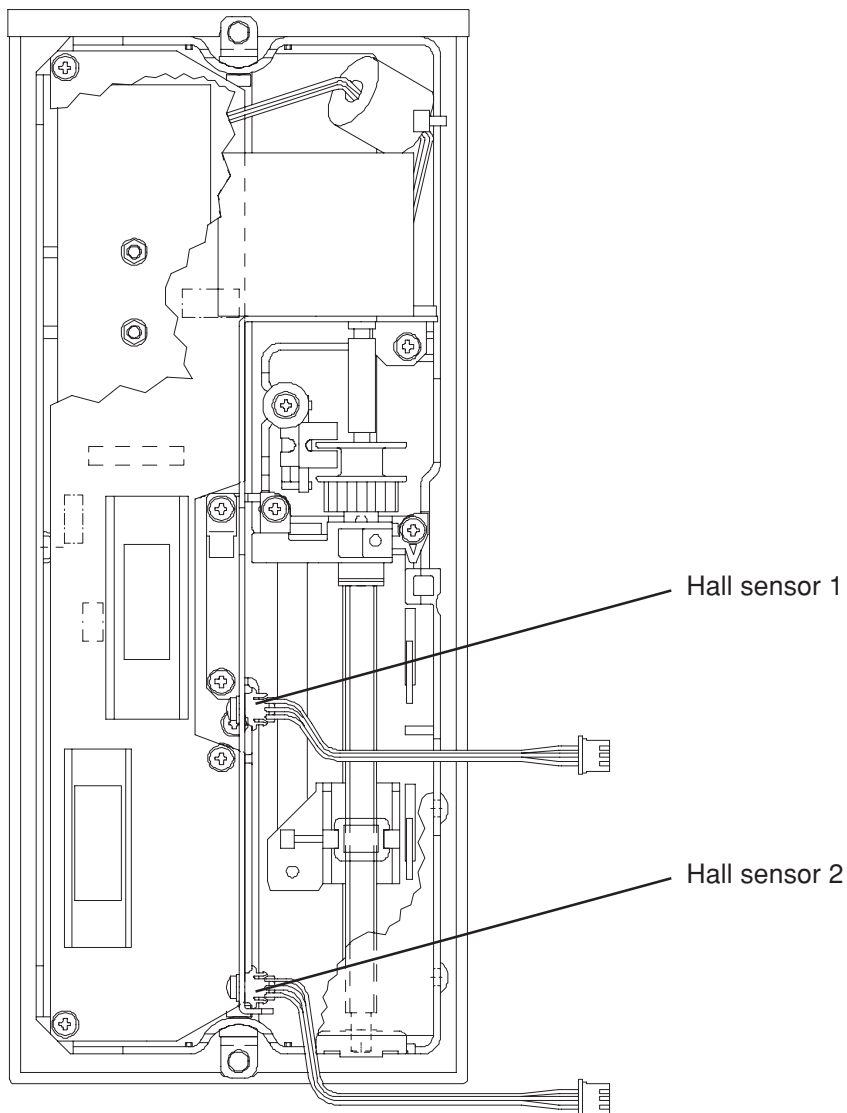

Table of contents

5 Diagnostics program

Section	Page
5.1 General notes	5-3
5.2 Menu structure	5-5
5.3 Reading the analog inputs of CPU I	5-7
5.4 Reading the analog inputs of CPU II	5-9
5.5 Reading the digital inputs of CPU I	5-10
5.6 Reading the digital inputs of CPU II	5-15
5.7 Writing the analog outputs of CPU I	5-19
5.8 Writing the analog outputs of CPU II	5-20
5.9 Writing the digital outputs of CPU I	5-21
5.10 Writing the digital outputs of CPU II	5-27
5.11 Writing/Reading the digital outputs of CPU I	5-30
5.12 ONLINE ^{plus} ™ module	5-31
5.13 HPU	5-32

5.1 General notes

The diagnostics program serves to activate all inputs and outputs of the hemodialysis system. Activation is related to CPU1 (P.C.B. LP 631), CPU2 (P.C.B. LP 632), as well as to the output board (P.C.B. LP 634) and the input board (P.C.B. LP 633).

Using this program, the technician is able to program his own settings for testing of error images.

The diagnostics program is divided into the following menus:

- READ INPUTS
 - READ ANALOG INPUTS
 - CPU1: RD ANALOG INP.
 - CPU2: RD ANALOG INP.
 - READ DIGITAL INPUTS
 - CPU1: RD DIGITAL INP
 - CPU2: RD DIGITAL INP
- WRITE OUTPUTS
 - WRITE ANALOG OUTPUTS
 - CPU1: WR ANALOG OUTP
 - CPU2: WR ANALOG OUTP
 - WRITE DIGIT. OUTPUTS
 - CPU1: WR DIGIT. OUTP
 - CPU2: WR DIGIT. OUTP
- INP/OUTP COMBINATION
 - CPU1: COMBINATION
- CAN-COMPONENTS
 - HPU
 - ONLINE-PLUS-MODUL

In order to indicate the corresponding levels, *a//UF*-seven-segment displays as well as the status indicator (monitor), the external traffic light and the loudspeaker are used in the "READ DIGITAL INPUTS" menu.

The *active* signal state (which may correspond to both present and absent voltage) is indicated by 1111 on the UF displays, activated traffic light (status indicator) and audible signal.

An audible signal can be deactivated by pressing the **(Alarm) Tone Mute** key. With the audible signal deactivated, the **(Alarm) Tone Mute** LED is flashing as a reminder.

The audible signal indication can be used to evaluate the state of the signal without having to look at the monitor. This may be advantageous in case measurements have to be made behind the system (e.g. hydraulic unit).



Note

In the diagnostics program, the signals are listed in the order of their electric connection, i.e. in latch groups of 8 signals each, according to the 8-bit data bus and according to the latch numbering on the circuit diagram (e.g. P.C.B. LP 633: CS_LATCH0 – CS_LATCH6).

They are *not* divided into groups of pertinency (e.g. all Bibag signals one after the other). The only exception here is the activation of the solenoid valves. These are listed in the menu in the order of their numbers. This facilitates finding each individual valve since, as a rule, several valves must be simultaneously activated for trouble shooting.

Since the signals are assigned to their respective connections (latch groups), it is possible at any time, by using the circuit diagram, to locate the respective signal in the menu, even if the signal name should have changed. Within one latch group, only *one* known signal suffices to find the renamed signal by counting through the menu.

Deviations of all voltage values indicated are possible due to tolerances and depending on the various systems.

The “CPU1: RD DIGITAL INP” menu item includes the “I:CPU1_KEY_TESTING” item, which serves to perform the key test.

The key actuated is indicated on the alphanumeric display.

The UP, DOWN, CONFIRM, SELECT and I/O keys have not been implemented, since their function can be tested by selecting the corresponding menu.

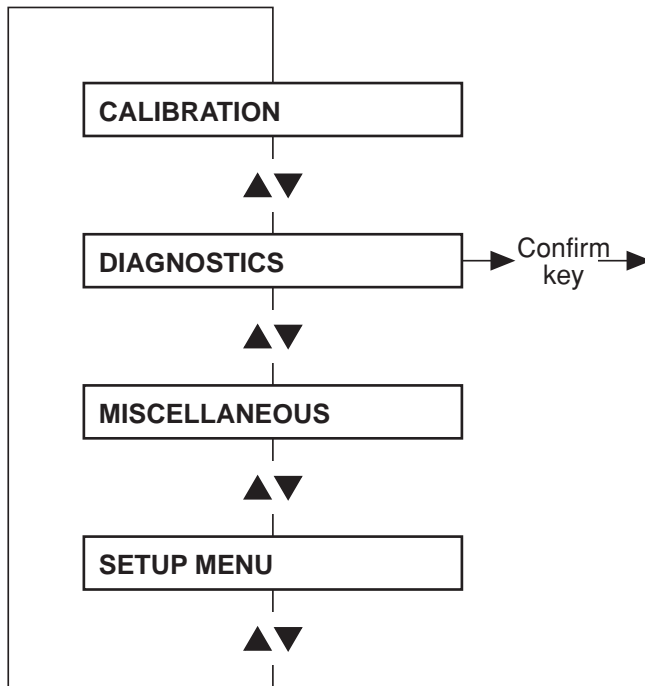

5.2 Menu structure

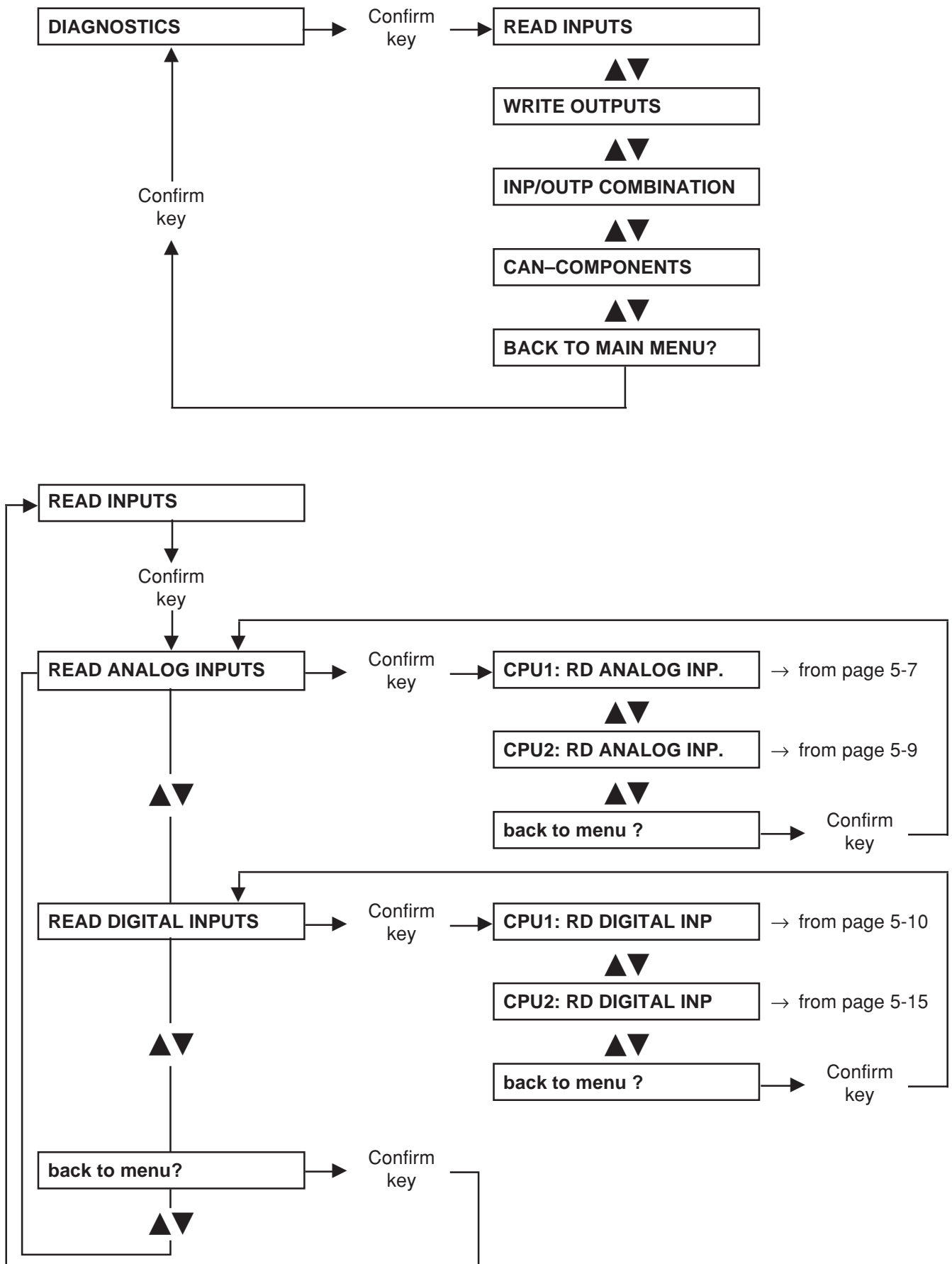

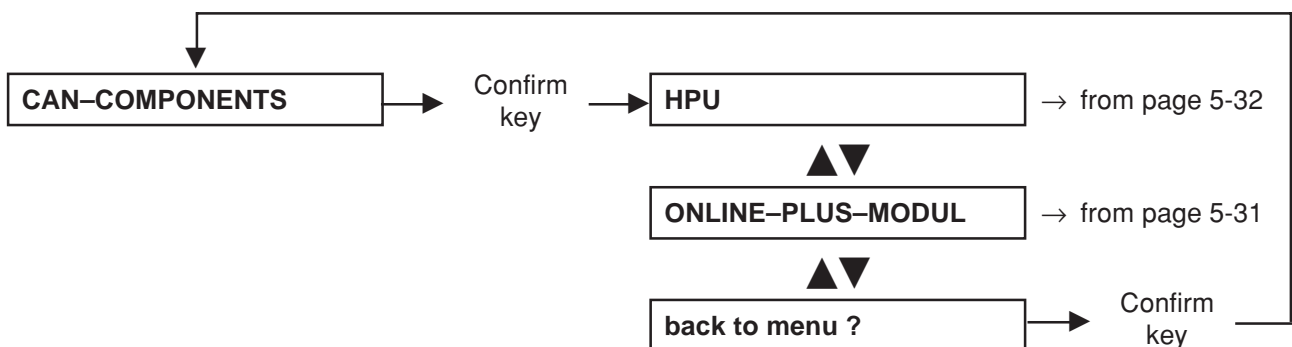
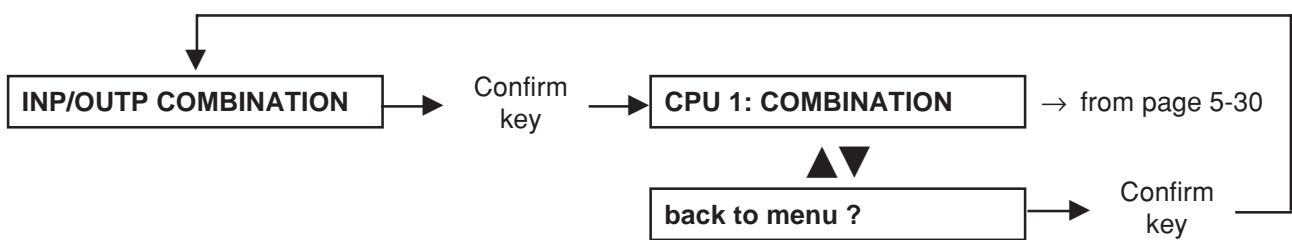
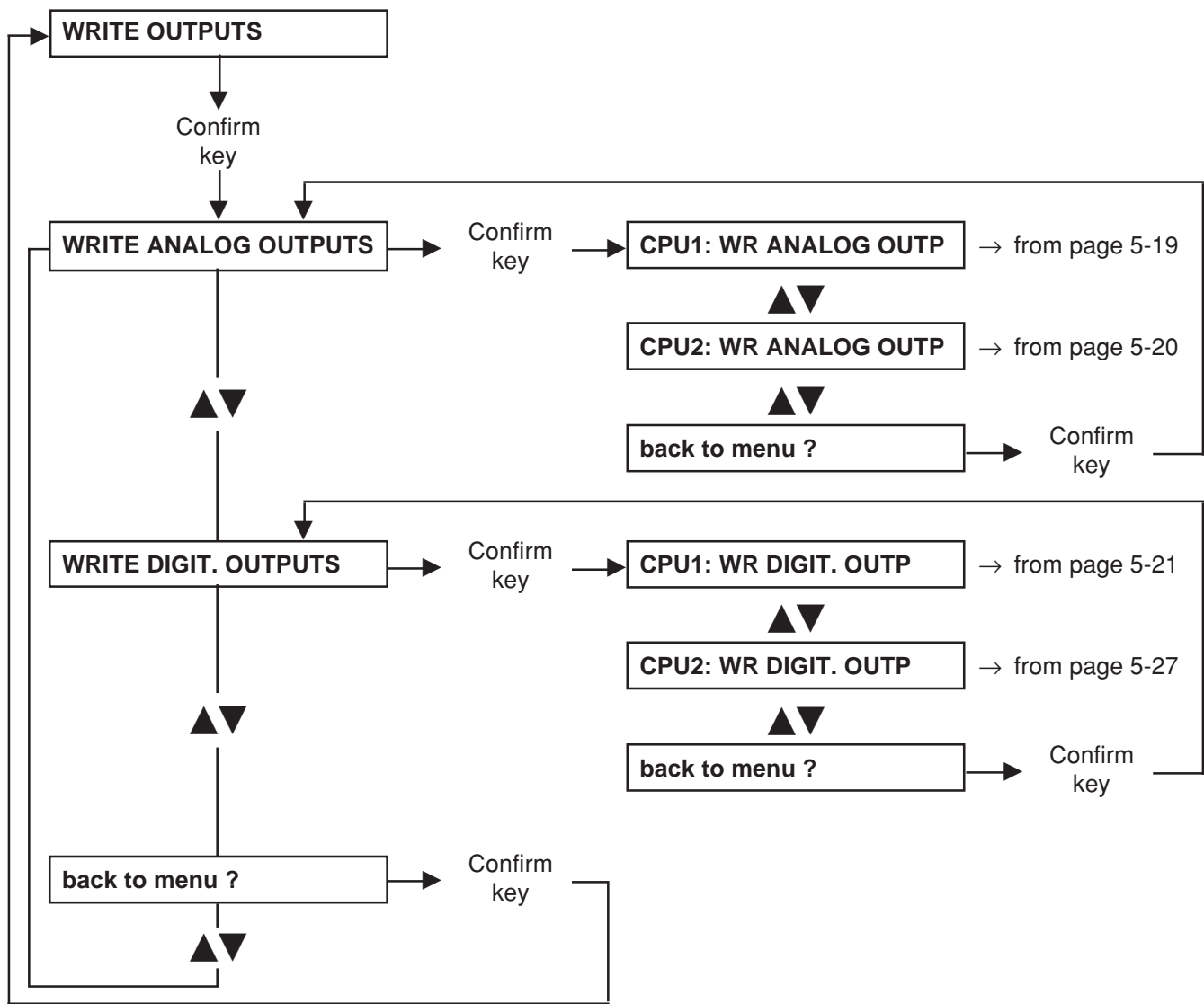

5.3 Reading the analog inputs of CPU I

Explanation:

UF Volume display: ADC value

Time Left display: Analog voltage (in 0.1 V), converted to the value at the input of P.C.B. LP 633

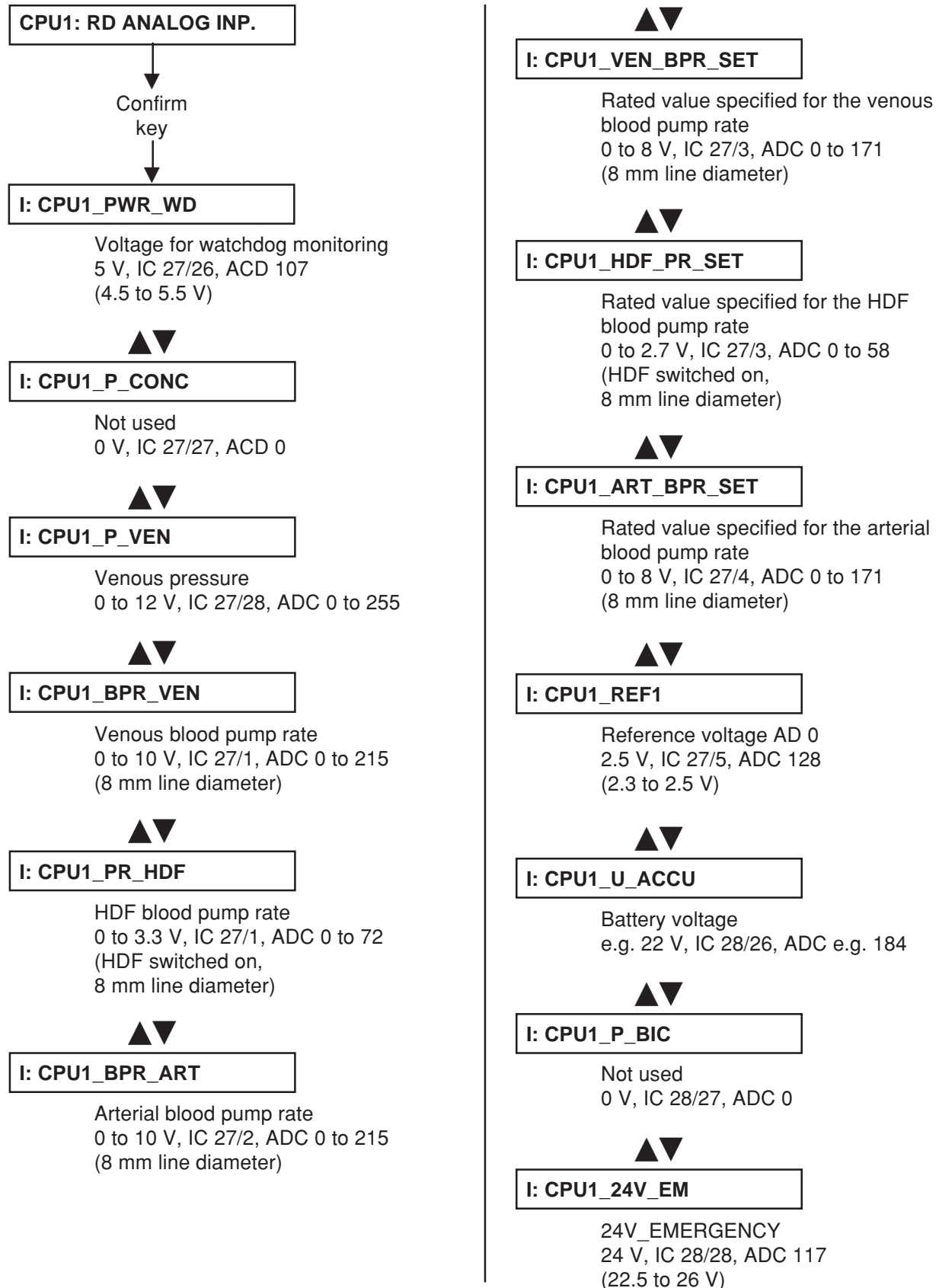



I: CPU1_P_ART

Arterial pressure
0 to 10.5 V, IC 28/1, ADC 0 to 225



I: CPU1_BLL_DIM

Blood leak dimness voltage
5.0 V, IC 28/2, ADC 108



I: CPU1_BLL

Blood leak voltage
5.0 V, IC 28/3, ADC 108



I: CPU1_COND_SIGNAL1

CD display
0 to 10.8 V, IC 28/4, ADC 0 to 231



I: CPU1_REF2

Reference voltage AD1
2.5 V, IC 28/5, ADC 128
(2.3 V to 2.5 V)



I: CPU1_FREE1

Not used
0 V, IC 29/26, ADC 0



I: CPU1_TEMP_DIAL2

Temperature NTC 109
0 to 12 V, IC 29/27, ADC 0 to 255



I: CPU1_COND_SINGAL2

Not used
0 V, IC 29/28, ADC 0



I: CPU1_TEMP_DIAL3

Temperature NTC
(slot X107 / LP 747)
0 – 12 V, IC 29/1, ADC 0 – 255



I: CPU1_COND_SIGNAL3

CD cell (slot X108 / LP 747)
0 – 10,8 V, IC 29/2, ADC 0 – 231



I: CPU1_FREE2

Not used, open input
IC 29/3



I: CPU1_U_BATT_SW

Voltage for alarm tone, if battery relay
is off
10.6 V, IC 29/4, ADC 110



I: CPU1_REF3

Reference voltage AD2
2.5 V, IC 29/5, ADC 128
(2.3 to 2.5 V)



back to menu ?

Confirm
key

CPU1: RD ANALOG INP.

5.4 Reading the analog inputs of CPU II

Explanation:

UF Volume display: ADC value

Time Left display: Analog voltage (in 0.1 V), converted to the value at the input of P.C.B. LP 632

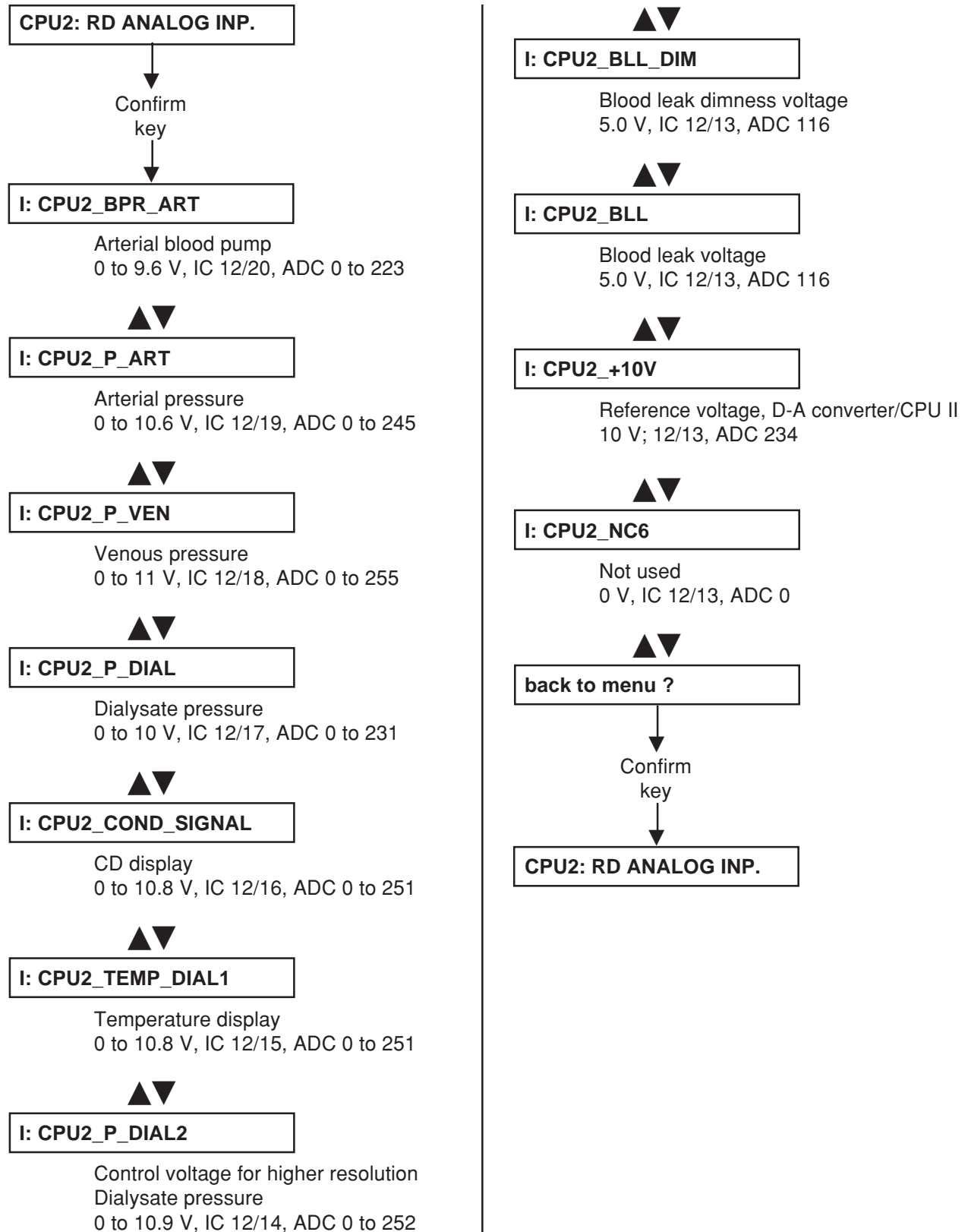

5.5 Reading the digital inputs of CPU I

Explanation:

All UF displays show 0000; red, yellow, green traffic light off: low level at latch on P.C.B. LP 633

All UF displays show 1111; red, yellow, green traffic light on: high level at latch on P.C.B. LP 633

If high level is applied, an audible alarm is simultaneously sounded. This tone can be suppressed by pressing the Alarm Tone Mute key. In this case, the Alarm Tone Mute LED is illuminated.

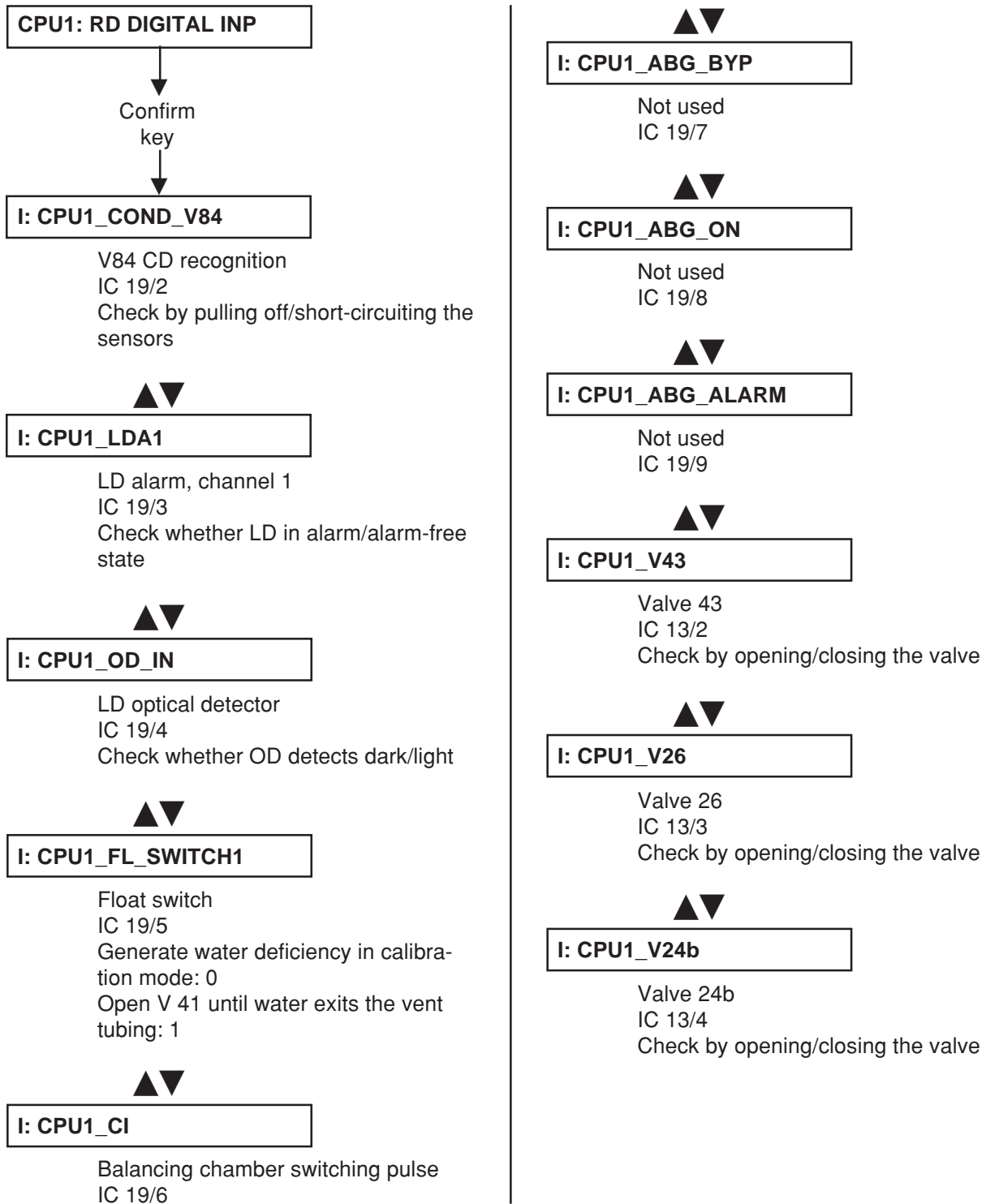

**I: CPU1_V24**

Valve 24
IC 13/5
Check by opening/closing the valve

**I: CPU1_UF_P1**

Acknowledgement of UF pump 1
IC 13/6
Check possible only in the combination menu

**I: CPU1_LDA2**

LD alarm, channel 2
IC 13/7
Preparation:
LD alarm-free and set CLAMP_CTRL
(CPU1: WR DIGIT. OUTP) to 1
Check: initiate an LD alarm

**I: CPU1_SUB_W_P**

Acknowledgement of UF pump 2
IC 13/8

**I: CPU1_LC11**

IC 13/9

**I: CPU1_REED_BIC**

Bicarbonate reed contact
IC 14/2
Actuate rinse chamber/bicarbonate reed contact

**I: CPU1_BIBAG**

Microswitch 137 / connector
IC 14/3
Check by connecting/removing the BIBAG

**I: CPU1_REED_RINSE**

Concentrate reed contact
IC 14/4
Actuate rinse chamber/concentrate reed contact

**I: CPU1_BIBAG_C**

Microswitch 138 / connector
IC 14/5
Check by connecting/removing the cap

**I: CPU1_PSW_V102**

Concentrate pressure switch
IC 14/6
Check by increasing/decreasing the pressure at the pressure switch

**I: CPU1_PSW_V104**

Bicarbonate pressure switch
IC 14/7
Check by increasing/decreasing the pressure at the pressure switch

**I: CPU1_PWR_OFF**

Power off
IC 14/8

**I: CPU1_HEP_ON**

Heparin pump on
IC 14/9
Switch heparin pump on/off

**I: CPU1_LA32**

IC 15/2

**I: CPU1_SW_ON_OFF**

On/off key on system
IC 15/3
Brief key actuation

**I: CPU1_PWR_FAIL**

Power failure recognition
IC 15/4

**I: CPU1_SHUNT_OUTP**

Microswitch, interlock shunt
IC 15/5
Both lines in the interlock shunt and interlock shunt closed: 0

**I: CPU1_SHUNT_INP**

Microswitch, interlock shunt
IC 15/6
Red line only in the interlock shunt and interlock shunt closed: 0

**I: CPU1_SHUNT**

Microswitch, interlock shunt
IC 15/7
Open/close interlock shunt

**I: CPU1_SERV_EN**

Not used
IC 15/8

**I: CPU1_LEV_SIGNAL**

Level sensor (NTC 6 – replacement)
IC 15/9
Check by removing/short-circuiting the sensor pins

**I: CPU1_SN**

Single-Needle changeover
IC 16/2
Changeover pressure of SN blood pump reached: 0

**I: CPU1_ADKS**

Single-Needle blood pump recognition connected
IC 16/3
Connect/remove the blood pump (only with the system off)

**I: CPU1_BPSB_ART**

Arterial blood pump stop confirmation
IC 16/4
Actuation of Start/Stop key on the arterial blood pump

**I: CPU1_BPUS_ART**

Arterial blood pump revolution stop
IC 16/5
Arterial blood pump alarm field on: 0 (cleared by pressing the Start/Stop key on the blood pump)

**I: CPU1_BPSB_VEN**

Venous blood pump stop confirmation
IC 16/6
Actuation of the Start/Stop key on the venous blood pump

**I: CPU1_BPUS_VEN**

Venous blood pump revolution stop
IC 16/7
Preparation:
Set SNST (CPU1: WR DIGIT. OUTP) to 1 and wait for the alarm field.
Venous blood pump on.
Check: clearing of the alarm field by pressing the Start/Stop key on the venous blood pump

▲▼
E. CPU1_HEP_ALARM

Heparin pump alarm
IC 16/8
Generate a heparin pump alarm
(e.g. by blocking the syringe slide)

▲▼
I: CPU1_BIB_LEVEL

Level sensor 135
IC 16/9
Check by removing/shorting the sensor
pins

▲▼
I: CPU1_EXT_ALARM

External alarm
IC 20/2
Release of an external alarm

▲▼
I: CPU1_SERVICE_MODE

Dialysis/calibration changeover
IC 20/3
Reset the service switch

▲▼
I: CPU1_LEVEL_UP

Raise the LD level
IC 20/4
Press the "Raise level" key

▲▼
I: CPU1_LEVEL_DOWN

Lower the LED level
IC 29/5
Preparation:
LD alarm-free, set CLAMP_CTRL
(CPU1: WR DIGIT. OUTP) to 1
Check: press the "Lower level" key

▲▼
I: CPU1_ADS_SN

Not used
IC 20/6

▲▼
I: CPU1_ACKN_CONC

Not used
IC 20/7

▲▼
I: CPU1_ACKN_BIC

Not used
IC 20/8

▲▼
I: CPU1_BIBAG_PSW

BIBAG pressure switch
IC 20/9
Check by increasing/decreasing pres-
sure on the pressure switch

▲▼
I: CPU1_RA21

Not used
IC 21/2

▲▼
I: CPU1_HDF_ON

HDF on
IC 21/3
Actuation of HDF On/Off switch

▲▼
I: CPU1_V102

Acknowledgement, valve 102
IC 21/4
Open/close the valve

▲▼
I: CPU1_V104

Acknowledgement, valve 104
IC 21/5
Open/close the valve

▲▼
I: CPU1_CSS_REED

IC 21/6

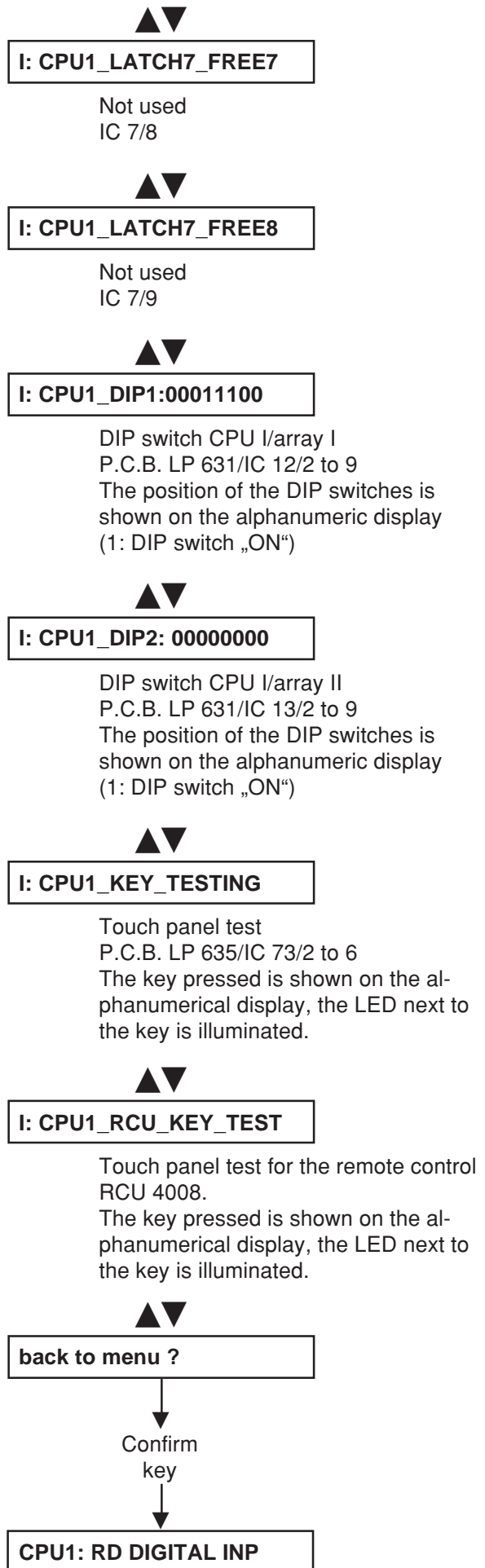
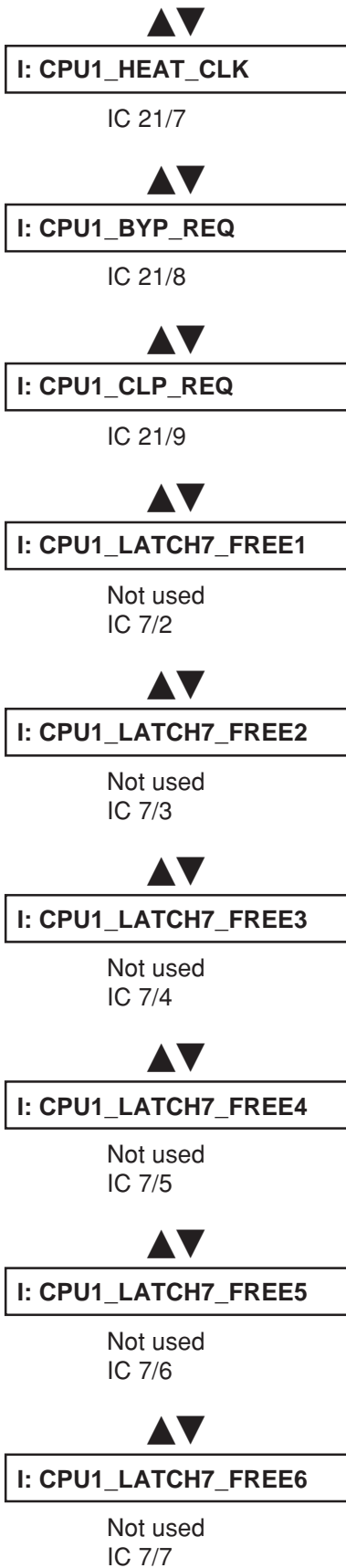

5.6 Reading the digital inputs of CPU II

Explanation:

All UF displays show 0000; red, yellow, green traffic light off: low level at latch on P.C.B. LP 632

All UF displays show 1111; red, yellow, green traffic light on: high level at latch on P.C.B. LP 632

If high level is applied, an audible alarm is simultaneously sounded. This tone can be suppressed by pressing the Alarm Tone Mute key. In this case, the Alarm Tone Mute LED is illuminated.

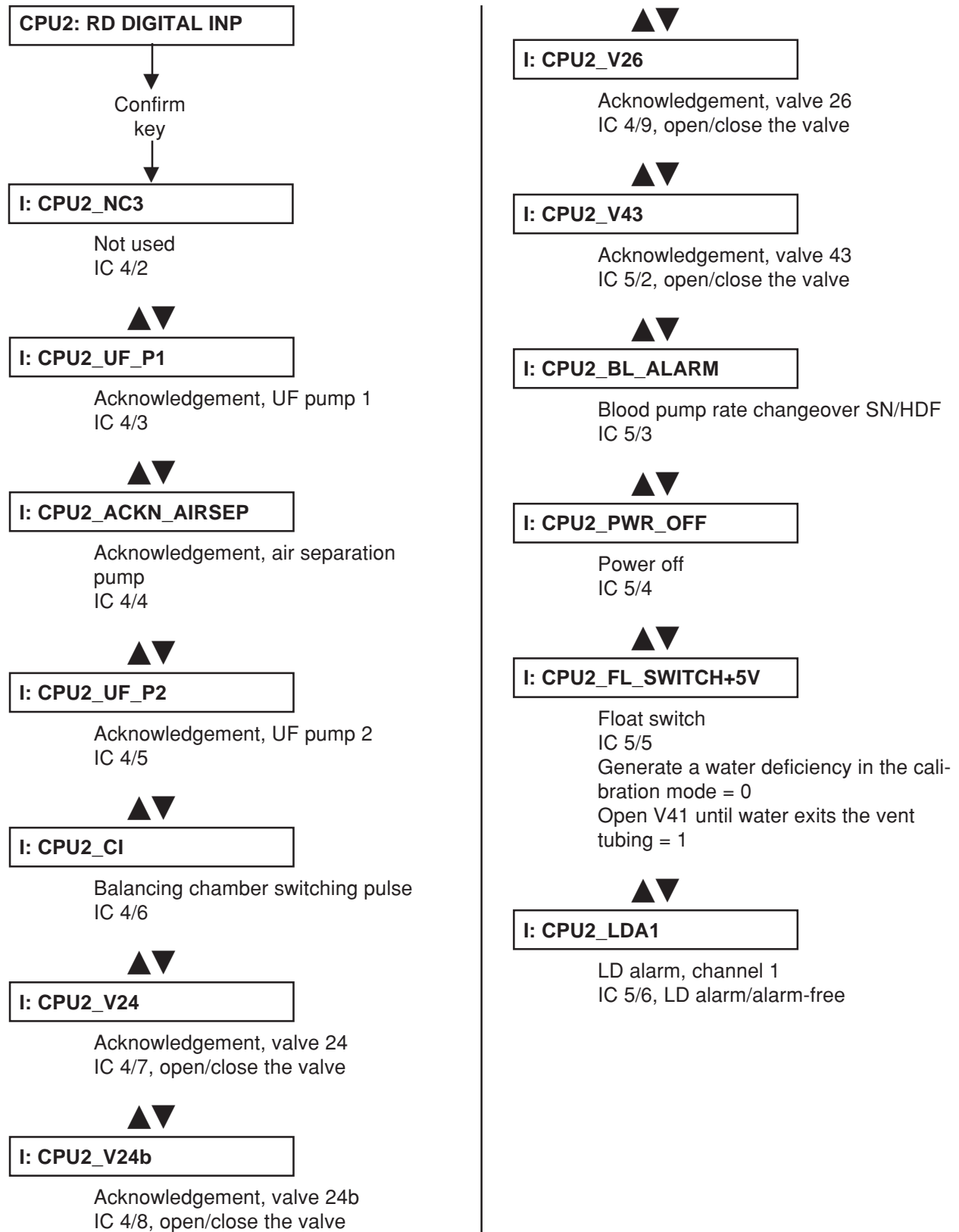

**I: CPU2_LDA2**

LD alarm, channel 2
 IC 5/7
 Preparation:
 LD alarm-free and set CLAMP_CTRL
 (CPU1: WR DIGIT. OUP) to 1
 Check: generate an LD alarm

**I: CPU2_BPSB_VEN**

Venous blood pump stop confirmation
 IC 5/8
 Actuation of the Start/Stop key on the
 venous blood pump

**I: CPU2_BPSB_ART**

Arterial blood pump stop confirmation
 IC 5/9
 Actuation of the Start/Stop key on the
 arterial blood pump

**I: CPU2_V42**

Not used
 IC 6/2

**I: CPU2_BPST_ART**

Acknowledgement, special control of
 the arterial blood pump
 IC 6/3
 Check by setting BPST_ART
 (CPU1: WR DIGIT. OUP) to 1/0

**I: CPU2_BPUS_ART**

Arterial blood pump revolution stop
 IC 6/4
 Alarm field of the arterial blood pump
 on = 0
 (cleared by pressing the Start/Stop key
 on the blood pump)

**I: CPU2_BPST_VEN**

Acknowledgement, special control of
 the venous blood pump
 IC 6/5
 Check by setting BPST_VEN
 (CPU1: WR DIGIT. OUP) to 1/0

**I: CPU2_BPUS_VEN**

Venous blood pump revolution stop
 IC 6/6
 Preparation:
 Set SNST (CPU1: WR DIGIT. OUP)
 to 1 and wait for the alarm field of the
 venous blood pump to turn on
 Check: clear the alarm field by press-
 ing the Start/Stop key on the venous
 blood pump

**I: CPU2_ADKS**

Single-Needle blood pump recognition
 connected
 IC 6/7
 Connect/remove the blood pump (with
 the system off only)

**I: CPU2_LEVEL_UP**

Raise LD level
 IC 6/8, press the "Raise level" key

**I: CPU2_LEVEL_DOWN**

Lower LD level
 IC 6/9
 Preparation:
 LD alarm-free, set CLAMP_CTRL
 (CPU1: WR DIGIT. OUP) to 1
 Check: press the "Lower level" key

**I: CPU2_RINSE**

Concentrate reed contact
 IC 7/2
 Actuate rinse chamber/concentrate
 reed contact

▲▼
I: CPU2_V147

IC 7/3

▲▼
I: CPU2_REED_BIC

Bicarbonate reed contact
IC 7/4
Actuate rinse chamber/bicarbonate reed contact

▲▼
I: CPU2_PSW_104

Bicarbonate pressure switch
IC 7/5
Check by increasing/decreasing pressure at the pressure switch

▲▼
I: CPU2_V145

IC 7/6

▲▼
I: CPU2_SHUNT_OUTP

Microswitch, interlock shunt
IC 7/7
Both lines in the interlock shunt and interlock shunt closed: 0

▲▼
I: CPU2_SHUNT_INP

Microswitch, interlock shunt
IC 7/8
Red line only in the interlock shunt and interlock shunt closed: 0

▲▼
I: CPU2_SHUNT

Microswitch, interlock shunt
IC 7/9, open/close the interlock shunt

▲▼
I: CPU2_ABG_ON

Not used
IC 8/2

▲▼
I: CPU2_SERVICE_MODE

Changeover dialysis/calibration
IC 8/3, reset the service switch

▲▼
I: CPU2_HOT_RINSE

Changeover hot rinsing
IC 8/4
Check by setting HOT_RINSE
(CPU1: WR DIGIT. OUTP) to 0/1

▲▼
I: CPU2_OD_OUT

LD optical detector
IC 8/5, optical detector light/dark

▲▼
I: CPU2_SNST

Single-Needle control
IC 8/6

▲▼
I: CPU2_24V_SW

24-V switch
IC 8/7

▲▼
I: CPU2_SN

Single-Needle changeover
IC 8/8, SN switching pressure reached: 0

▲▼
I: CPU2_HEAT_RL_WATCH

Acknowledgement, heater relay
IC 8/9

▲▼
I: CPU2_DIP1: 01100110

DIP switch CPU II/array I
IC 9/2 to 9
DIP switch position shown on the alphanumeric display
(1: DIP switch „ON“)



I: CPU2_DIP2: 11000001

DIP switch CPU II/array II
IC 10/2 to 9
DIP switch position shown on the
alphanumeric display
(1: DIP switch „ON“)



back to menu ?



CPU2: RD DIGITAL INP

5.7 Writing the analog outputs of CPU I

Explanation:

UF Rate display: DAC value (can be changed with: 4008/E/B: ▲▼ UF Rate, 4008 H/S: +/-)

Time Left display: Analog voltage on P.C.B. LP 634, in 0.1 V

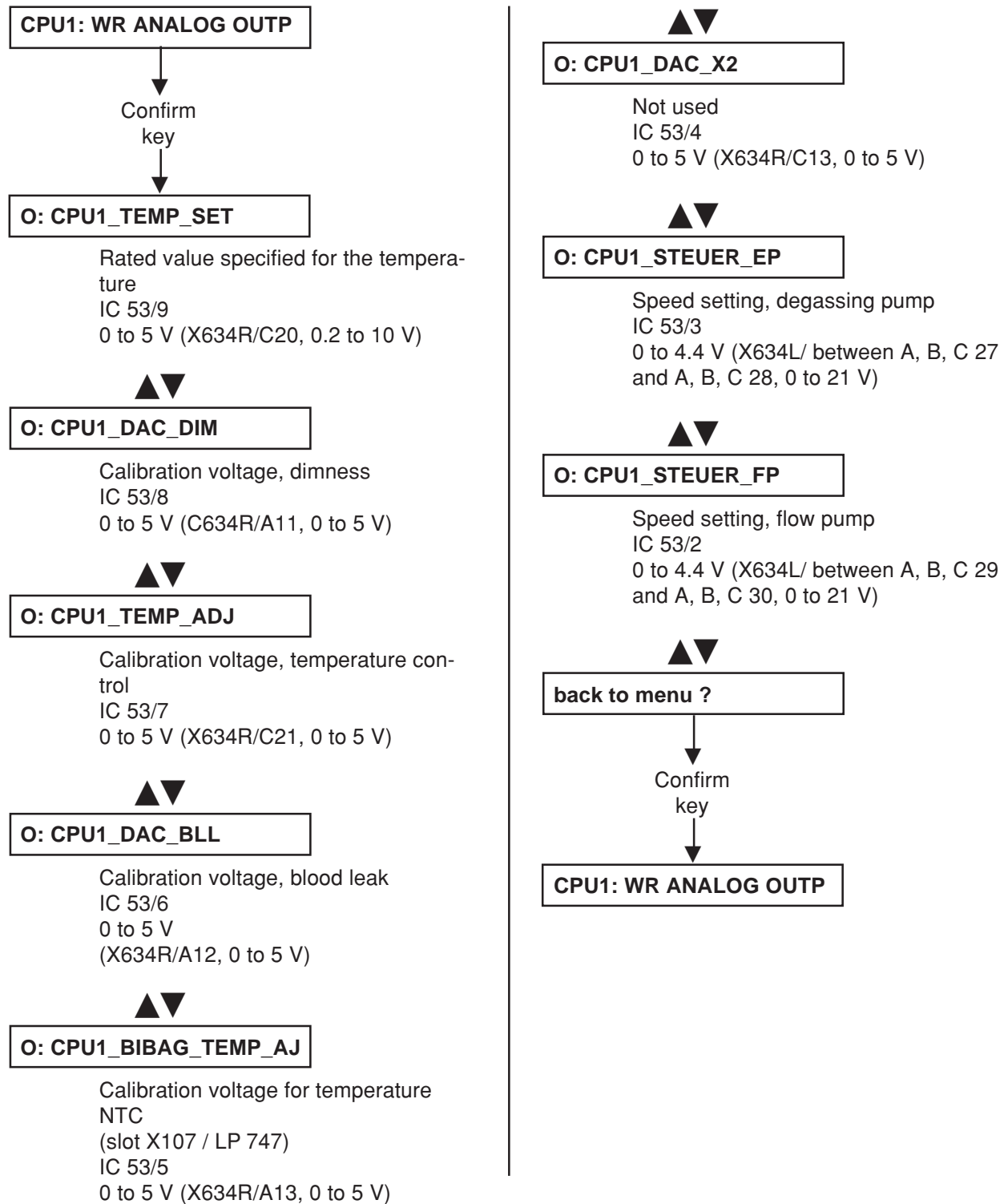

5.8 Writing the analog outputs of CPU II

Explanation:

UF Rate display: DAC value (can be changed with: 4008/E/B: ▲▼ UF Rate, 4008 H/S: +/-)

Time Left display: Analog voltage on P.C.B. LP 632, in 0.1 V

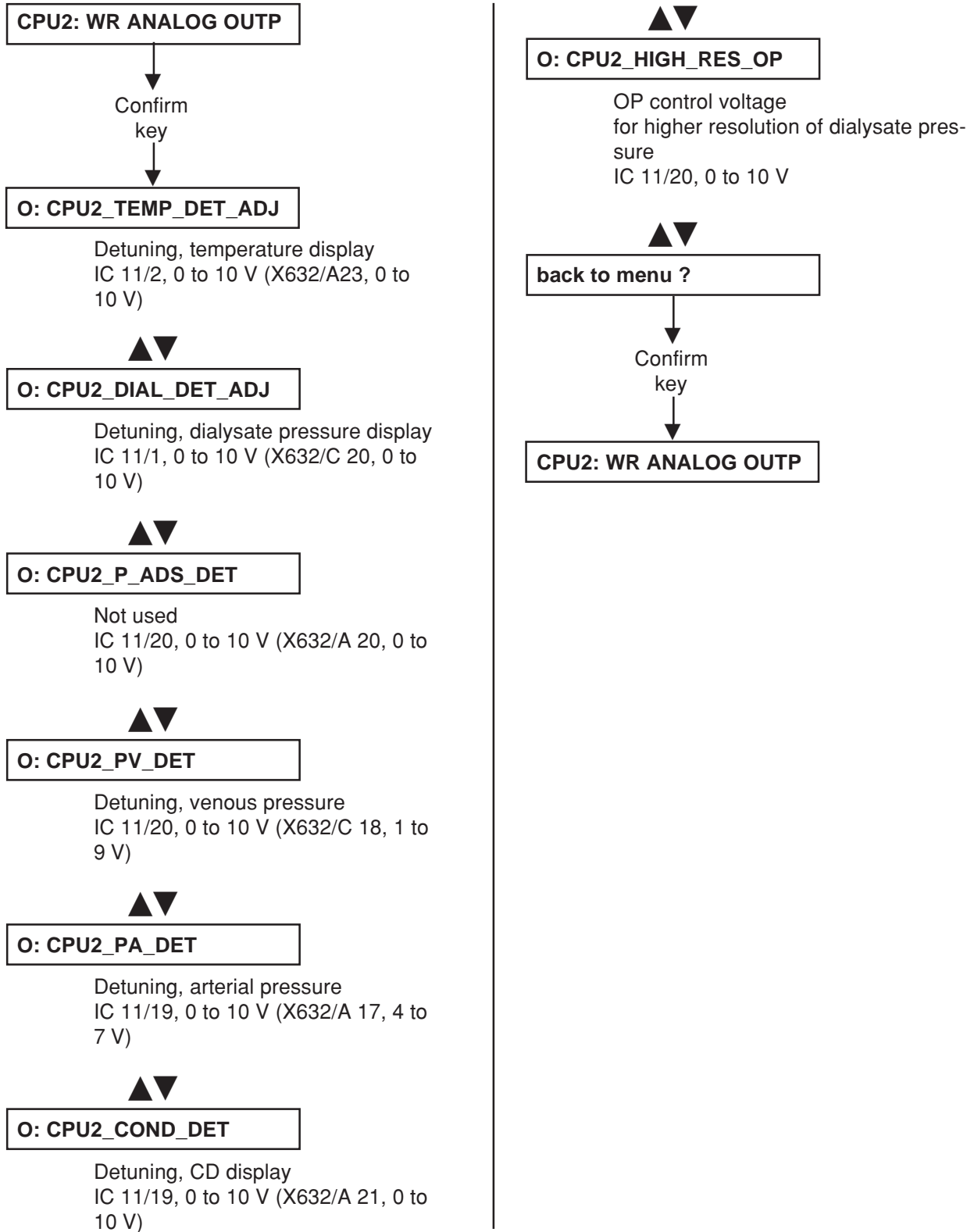

5.9 Writing the digital outputs of CPU I

Explanation:

UF Rate display: 0000 = not active
 1111 = active (P.C.B. LP 634 level)
 (can be changed with: 4008/E/B: ▲▼ UF Rate, 4008 H/S: +/-)

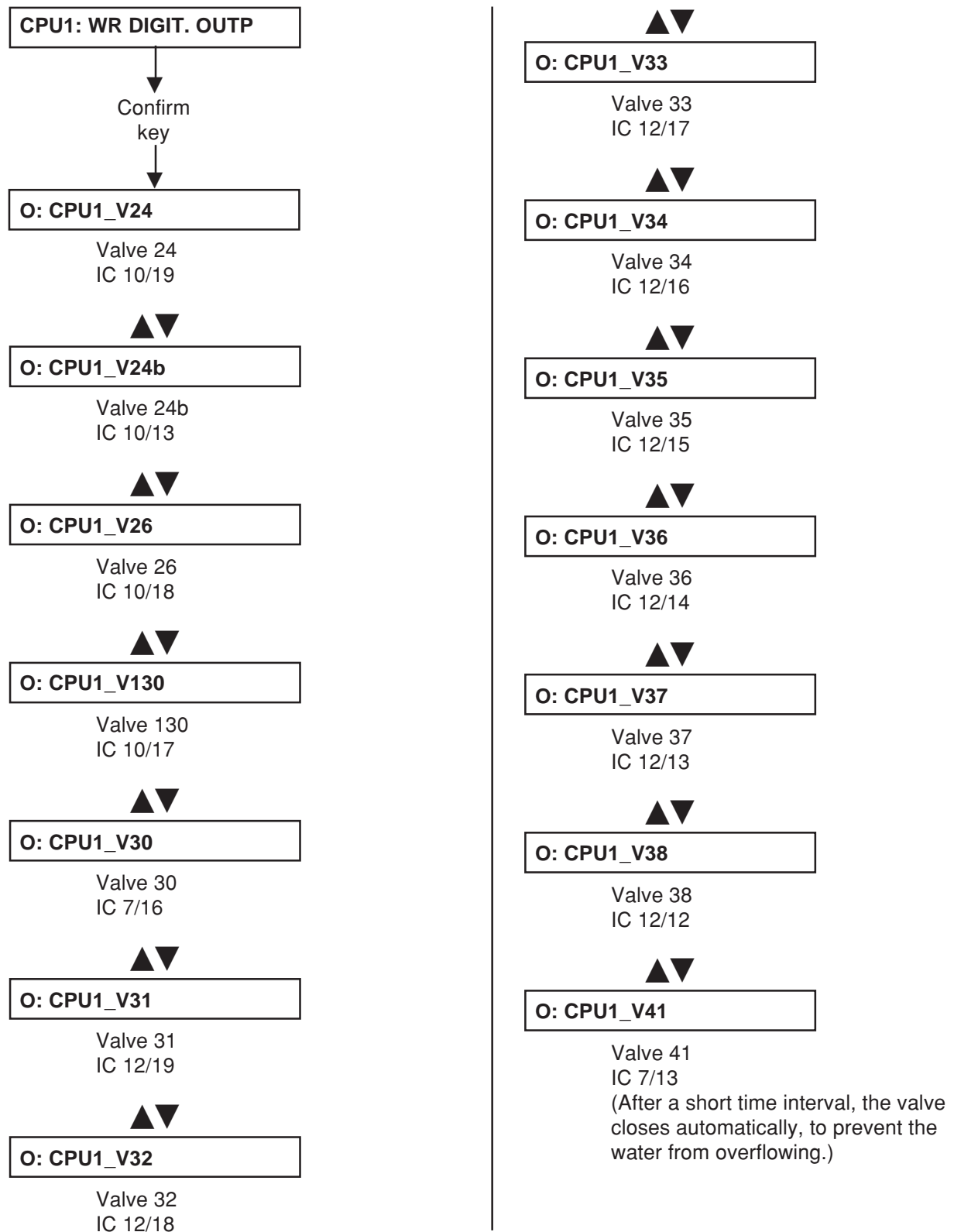



O: CPU1_V43

Valve 43
IC 7/15



O: CPU1_V84

Valve 84
IC 7/18
Note: After the valve V84 has been activated, rinsing is mandatory.



O: CPU1_V86

Valve 86
IC 7/17



O: CPU1_V87

Valve 87
IC 10/15



O: CPU1_V91

Valve 91
IC 10/14
Note: When exiting this menu option (return to „CPU1: WR DIGIT. OUTP“) the valve will be closed.



O: CPU1_V99

Valve 99
IC 7/19
Note: When exiting this menu option (return to „CPU1: WR DIGIT. OUTP“) the valve will be closed.



O: CPU1_V100

Valve 100
IC 4/17
Note: When exiting this menu option (return to „CPU1: WR DIGIT. OUTP“) the valve will be closed.



O: CPU1_V102

Valve 102
IC 10/12
(Activation of the valve is possible only if a mandatory rinse is not requested.)



O: CPU1_V104

Valve 104
IC 7/14
(Activation of the valve is possible only if a mandatory rinse is not requested.)



O: CPU1_V126

Not used



O: CPU1_V145

Not used



O: CPU1_V147

Not used



O: CPU1_V172

Not used



O: CPU1_V173

Not used



O: CPU1_AIR_SEP_PUMP

Air separation pump
IC 4/18, 19
(1111: clockwise)
Note: When exiting the menu option, the ASP stops

▲▼

O: CPU1_STOP_EP

Stopping of the degassing pump
IC 4/16

▲▼

O: CPU1_STOP_FP

Stopping of the flow pump
IC 4/15

▲▼

O: CPU1_SET_UF1_ON

Activation of UF pump 1
IC 4/14
(0/1 jump = 1 stroke)

▲▼

O: CPU1_SET_UF2_ON

Activation of UF pump 2
IC 4/13
(0/1 jump = 1 stroke)

▲▼

O: CPU1_SET_EN_UF2

Not used
IC 4/12

▲▼

O: CPU1_SET_FLOW_ON

Flow on
Dataword to Gal 23:
0000 0010 (active, V 32 open)
0000 0011 (inactive, V 31, 32 open)

▲▼

O: CPU1_SET_FILL_PRG

Fill program
Dataword to Gal 23:
0000 1010 (V 32, 34 open)

▲▼

O: CPU1_EMPTYING_PRG

Emptying program:
Dataword to Gal 23:
0001 0010 (V 32, 35 open)

▲▼

O: CPU1_FILL_ONE_CHAM

Filling of a balancing chamber compartment
Dataword to Gal 23:
0100 0010 (V 32, 37 open)

▲▼

O: CPU1_EMPTY_ONE_CHA

Emptying of a balancing chamber compartment
Dataword to Gal 23:
1100 0010 (V 32, 37, 38 open)

▲▼

O: CPU1_CO:L:XXXXXXXX

Step number of concentrate pump
The dataword to IC 2 is indicated on the alphanumeric display and can be changed by pressing the UF Rate UP/DOWN keys.
Prerequisite: reed contact of concentrate connector open

▲▼

O: CPU1_BI_L:XXXXXXXX

Step number of bicarbonate pump
Prerequisite: reed contact of bicarbonate connector open

▲▼

O: CPU1_ALARM_SOUND

Alarm tone
IC 5/18, 19 set to 1: active

▲▼

O: CPU1_WARN_SOUND

Warning tone
IC 5/18 set to 1, 19 to 0: active

▲▼

O: CPU1_INFO_SOUND

Infosound
IC 5/18 set to 0, 19 to 1: active

▲▼

O: CPU1_CLK_OVERLAP

Changeover of dead time of balancing chamber
IC 5/17 set to 0: 1 kHz; to 1: 2 Hz

**O:CPU1_EN_IN_PULSE**

Changeover, "Eigentakt"
 IC 5/16 set to 0: "Eigentakt"; to 1:
 changover current rise

**O: CPU1_BC_PULSE**

Balancing chamber switching
 IC 5/15

**O: CPU1_EN_STEP_PULS**

Gal changeover
 IC 5/14

**O: CPU1_BC_FUNCTION**

Activation of balancing chamber gal
 IC 5/13

**O: CPU1_STEPPER_PULS**

"Eigentakt"
 IC 5/12

**O: CPU1_FL_SWITCH_EN**

V41 release
 IC 7/12
 Check:
 Set level to 1 and float switch down:
 V 41 open
 Set level to 0 and float switch down:
 V 41 closed

**O: CPU1_SNST**

Single-Needle control
 IC 13/19
 Preparation:
 LD alarm-free and set CLAMP_CTRL
 (CPU1: WR DIGIT. OUTP) to 1
 Check:
 SNST set to 1: as soon as the SN
 changeover pressure is reached, the
 venous blood pump is running

**O: CPU1_CPU_OFF**

Automatic switchoff
 IC 13/18
 In position 1, the system switches off

**O: CPU1_EN_PF_AT**

Release of audible power failure alarm
 IC 13/17
 Preparation: set WD_SET
 (CPU2: WR DIGIT. OUTP)
 Check: with EN_PF_AT set to 0/1, the
 power failure alarm can be switched
 on/off

**O: CPU1_PIC_RA3**

Not used
 IC 13/16

**O: CPU1_PROG_LOG1**

Program logic 1, HDF pump
 IC 13/14
 (0: speed 200; 1: speed 400)

**O: CPU1_PROG_LOG2**

Program logic 2, HDF pump
 IC 13/13
 (0: speed 200; 1: speed 150)

**O: CPU1_VENT_VALVE**

LD vent valve
 IC 13/12

**O: CPU1_CLR_ALARM**

Clearing of the alarm
 IC 11/18
 Check: generate a heparin pump alarm; by setting CLR_ALARM from 0 to 1, the alarm is cleared.

**O: CPU1_HOT_RINSE**

Changeover, hot rinsing
 IC 11/17

**O: CPU1_TEST_BATT**

Battery test
 IC 11/16

**O: CPU1_CPU_AKKU**

Battery relay
 IC 11/15

**O: CPU1_HEAT_OFF**

Heater blocking
 IC 11/14

**O: CPU1_STAFF_CALL**

Staff call
 IC 11/13

**O: CPU1_TL_RED**

Traffic light red
 IC 11/12
 (The pertinent status indicator on the front panel lights simultaneously.)

**O: CPU1_BPST_ART**

Special control of the arterial blood pump
 IC 6/19

**O: CPU1_BPSST_ART**

Arterial blood pump system stop
 IC 6/18

**O: CPU1_CLAMP_CTRL**

LD clamp control
 IC 6/17
 Preparation: LD in no alarm state

**O: CPU1_BPST_VEN**

Special control of the venous blood pump
 IC 6/16

**O: CPU1_BPSST_VEN**

Venous blood pump system stop
 IC 6/15
 Preparation:
 Set SNST (CPU1: WR DIGIT. OUTP) to 1
 Check: apply pressure to the SN blood pump; with BPSST_VEN, the blood pump can be switched on/off.

**O: CPU1_BL_ALARM**

Changeover, blood pump rate
 Single-Needle/HDF
 IC 6/14

**O: CPU1_TL_YELLOW**

Traffic light yellow
 IC 6/13
 (The pertinent status indicator on the front panel lights simultaneously.)

**O: CPU1_TL_GREEN**

Traffic Light green
 IC 6/12
 The pertinent status indicator on the front panel lights simultaneously.



O: PUMP FASTER

4008 H/S: **O: CPU1_BP_FASTER**

Increase blood pump rate +
(RCU 4008)
LP 649/X4.4; LP 635/X4.4;
LP 922/X5.4; LP 924/X6.4



O: PUMP SLOWER

4008 H/S: **O: CPU1_BP_SLOWER**

Decrease blood pump rate –
(RCU 4008)
LP 649/X4.5; LP 635/X4.5;
LP 922/X5.5; LP 924/X6.5



O: CPU1_OVERLAP_VALUE

Charging of the dead time counter
IC 3/12 to 19
(DAC adjustable from 0 to 255)



O: CPU1_V_ADS

Not used



O: CPU1_NC_I

Not used



O: CPU1_NC_II

Not used



O: CPU1_NC_III

Not used



O: CPU1_ACKN_FLOW

Not used



O: CPU1_ACKN_BL_ALARM

Not used



O: CPU1_DISPLAY_TEST

All LED indicators are tested.
The display on the UF monitor counts
from 1 to 0.



back to menu ?

Confirm
key

CPU1: WR DIGIT. OUTP

5.10 Writing the digital outputs of CPU II

Explanation:

UF Rate display: 0000 = not active
 1111 = active (P.C.B. LP 632 level)
 (can be changed with: 4008/E/B: ▲▼ UF Rate, 4008 H/S: +/-)

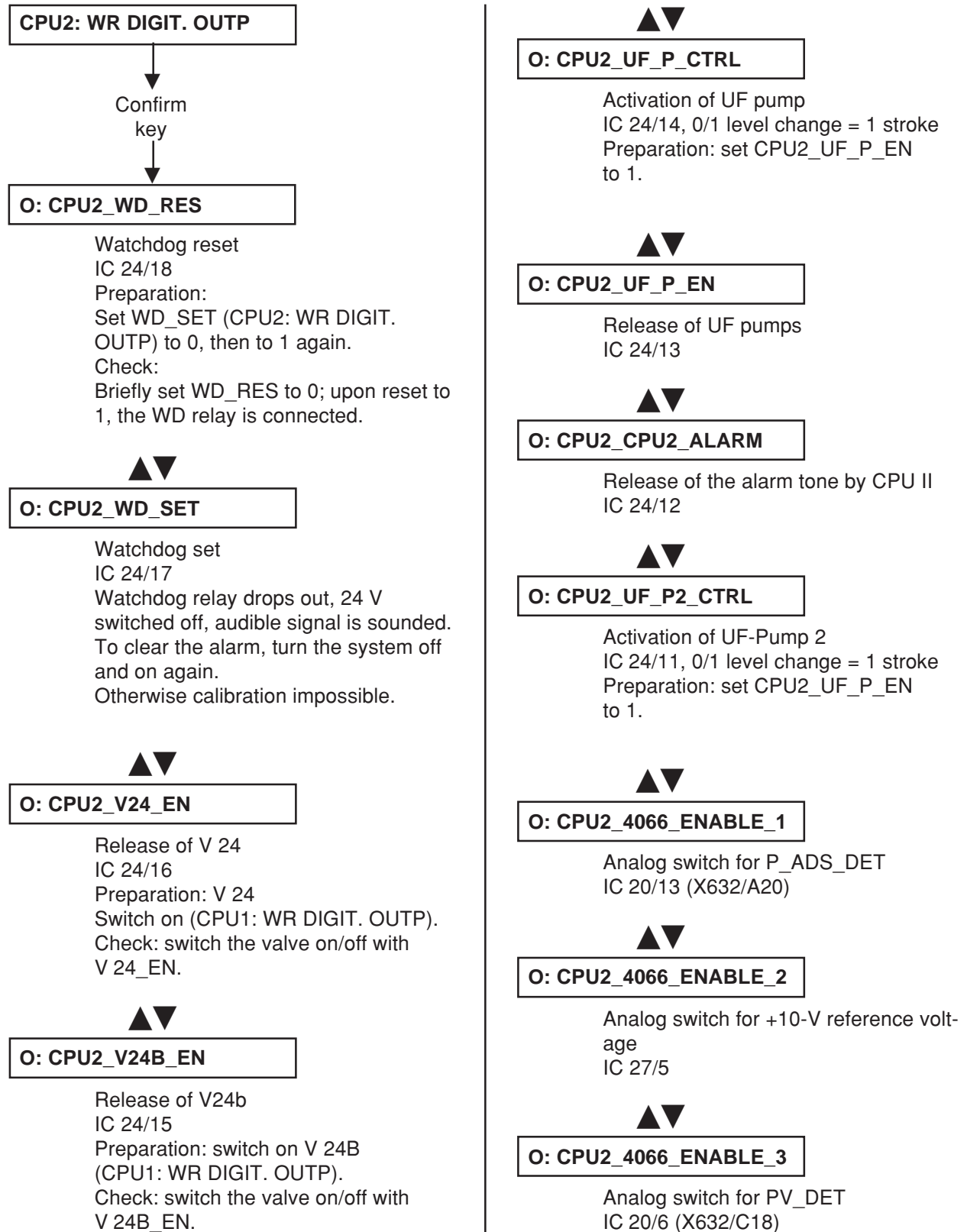



O: CPU2_4066_ENABLE_4

Analog switch for PA_DET
IC 20/12 (X632/A17)



O: CPU2_4066_ENABLE_5

Analog switch, not used
IC 27/13



O: CPU2_4066_ENABLE_6

Analog switch for COND_DET
IC 20/5 (X632/A21)



O: CPU2_4066_ENABLE_7

Analog switch for BLL_DIM
IC 27/6



O: CPU2_4066_ENABLE_8

Analog switch for BLL
IC 27/12



O: CPU2_SN_ART

Single-Needle control, arterial
X632/A15



O: CPU2_LDSA

Attenuation of LD ultrasonic sensor
X632/C16
Preparation:
LD alarm-free and set CLAMP_CTRL
(CPU1: WR DIGIT. OUTP) to 1.
Check: by setting LDSA to 1, the
clamp at the LD closes.



O: CPU2_ODSA

Attenuation of LD optical sensor
X632/C15



O: CPU2_CLAMP_CTRL

Clamp control, air detector
X632/C10
Preparation: LD in no alarm state



O: CPU2_NC5

Not used
X632/B25



O: CPU2_NC7

Not used
X632/B10



O: CPU2_BLL_DET

Detuning of blood leak detector
X632/A25



O: CPU2_SN_EN

Release of Single-Needle
X632/C19



O: CPU2_NC10

Not used
X632/B4



O: CPU2_V26

Valve 26
X632/A6



O: CPU2_V42

Not used
X632/C4



O: CPU2_V43

Valve 43
X632/C5

▲▼
O: CPU2_VENT_DSAFE

Vent valve, Diasafe
X632/B5

▲▼
O: CPU2_EM_HEAT_OFF

Heater relay
X632/A9
For safety reasons, the relay switches
off again after having been activated.

▲▼
O: CPU2_NC8

Not used
X632/B9

▲▼
O: CPU2_NC9

X632/C6
IC 29/13

▲▼
O: CPU2_LED1

P.C.B. LP 632, LED 1
IC 21/19

▲▼
O: CPU2_LED2

P.C.B. LP 632, LED 2
IC 21/18

▲▼
O: CPU2_LED3

P.C.B. LP 632, LED 3
IC 21/17

▲▼
O: CPU2_LED4

P.C.B. LP 632, LED 4
IC 21/16

▲▼
O: CPU2_LED5

P.C.B. LP 632, LED 5
IC 21/15

▲▼
O: CPU2_LED6

P.C.B. LP 632, LED 6
IC 21/14

▲▼
O: CPU2_LED7

P.C.B. LP 632, LED 7
IC 21/13

▲▼
O: CPU2_LED8

P.C.B. LP 632, LED 8
IC 21/12

▲▼
back to menu ?

↓
Confirm
key
↓

CPU2: WR DIGIT. OUTP

5.11 Writing/Reading the digital outputs of CPU I

Explanation:

UF Volume display: Acknowledgement/input (in case of 1111, the three status LEDs of the traffic light are also illuminated)

UF Rate display: Activation/output (can be changed with: 4008/E/B: ▲▼ UF Rate, 4008 H/S: +/-)

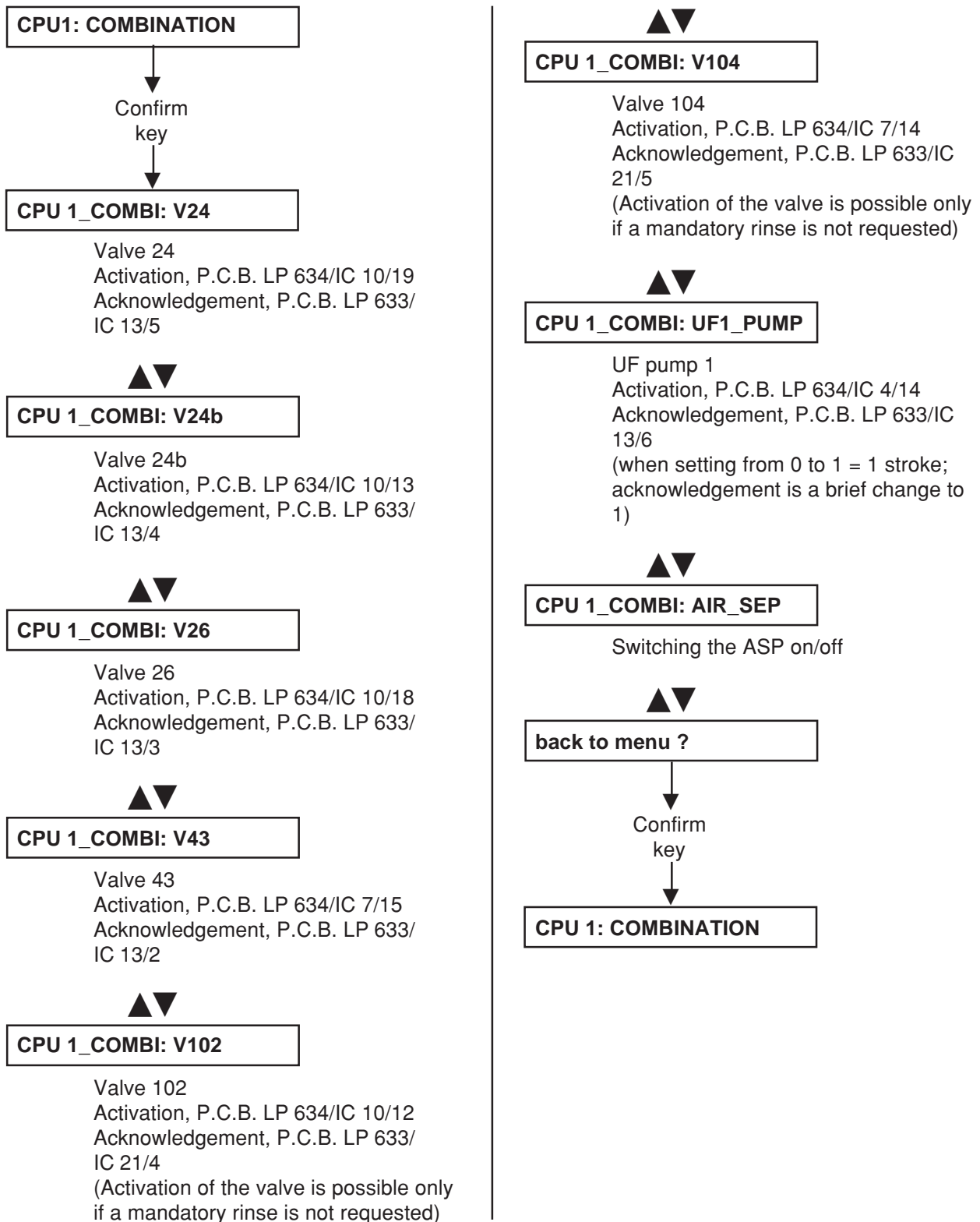

5.12 ONLINE^{plus}™ module

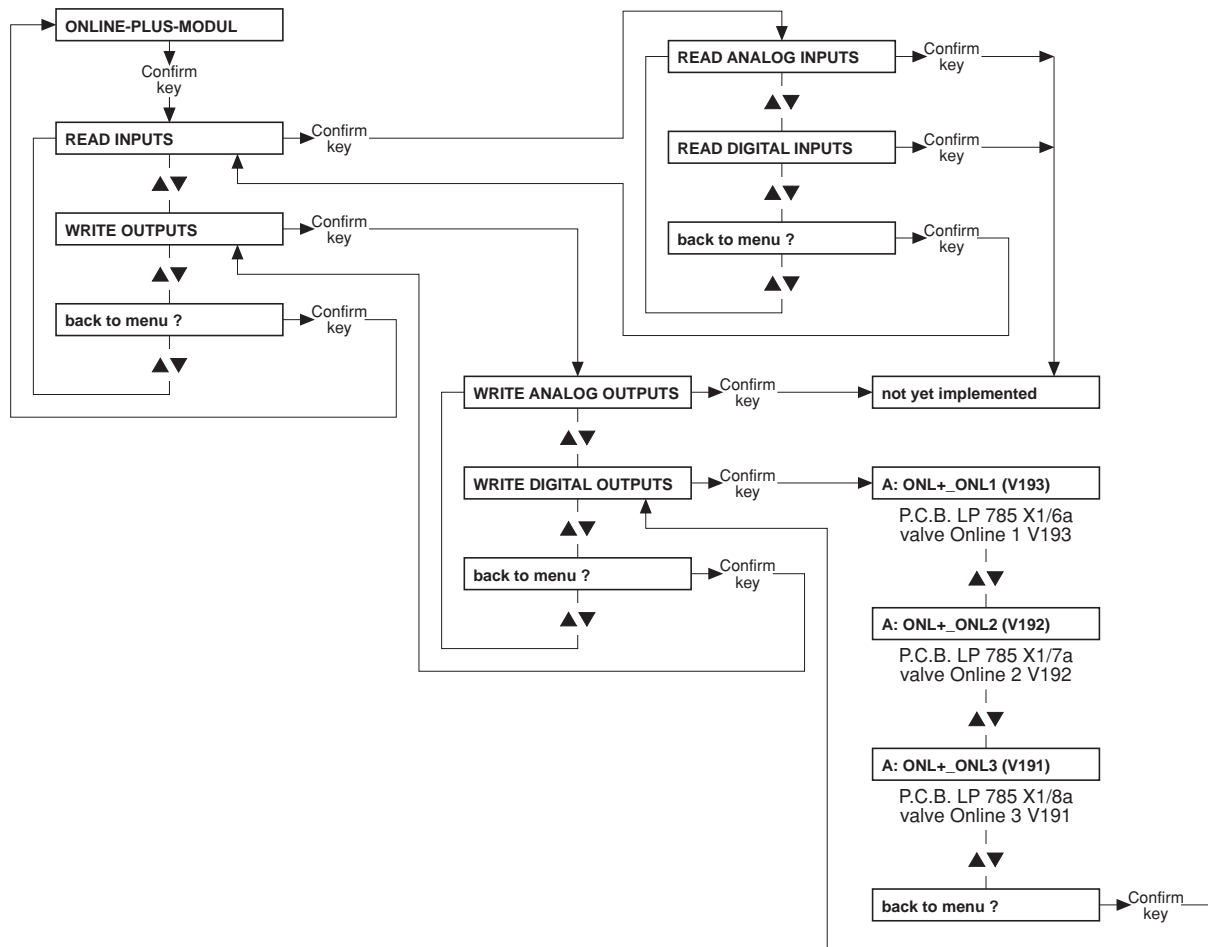

5.13 HPU

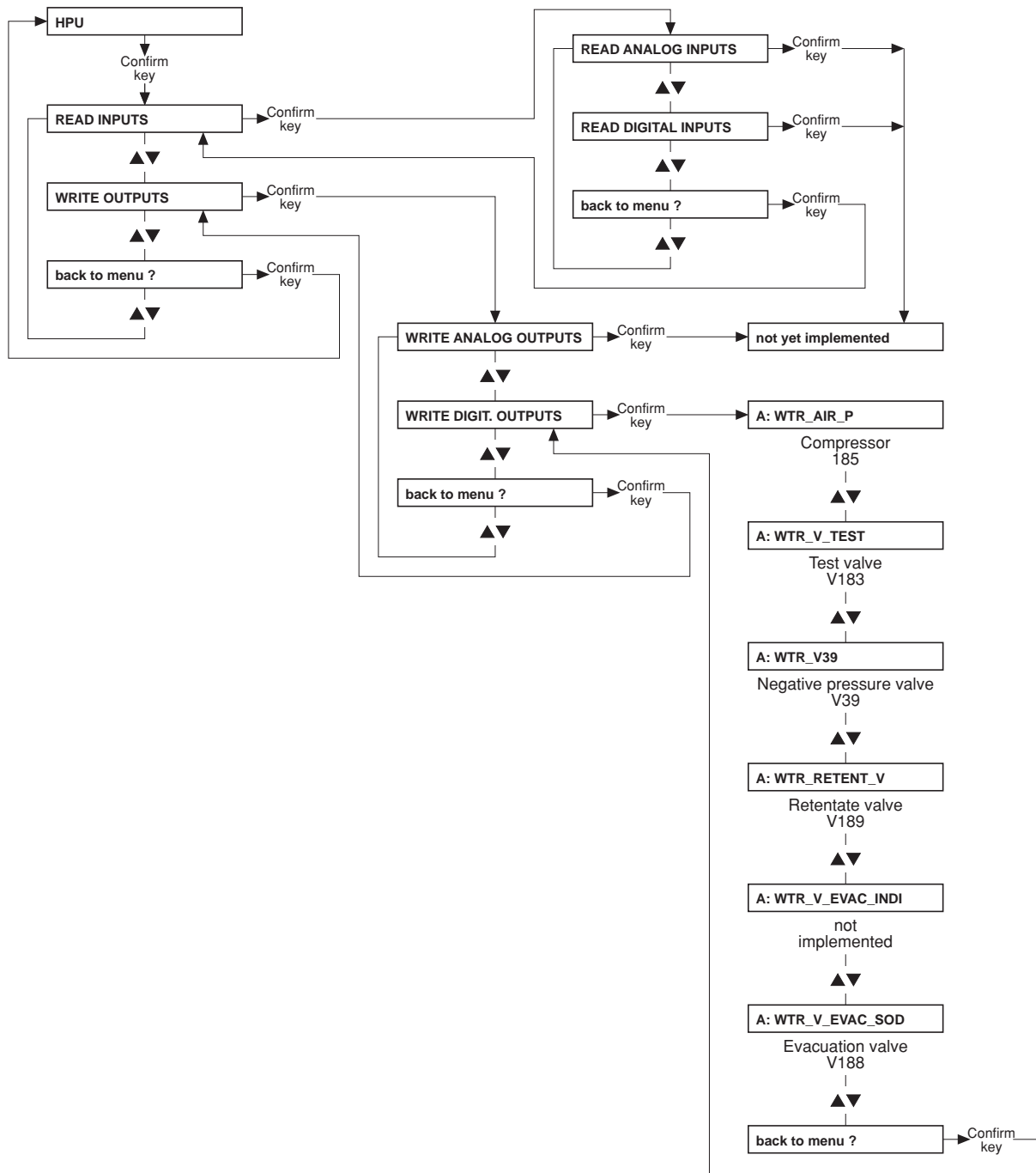

Table of contents

6 Setup menu

Section		Page
6.1	Overview Setup menu settings	6-3
6.2	Overview	6-7
6.3	Main menu 4008 E/B	6-9
6.4	Main menu 4008 H/S	6-37

6.1 Overview Setup menu settings

Menu item	Submenu	Default value	Value range	Resolution
SET ALARM/WARN TIME	Set ART-AL DELAYTIME	5 sec	0 – 5 sec	1 sec
	Set VEN-AL DELAYTIME	5 sec	0 – 5 sec	1 sec
	Set FLOW-OFF W-TIME	30 min	30 – 60 min	15 min
	Set UF-WARNING-TIME	10 min	10/30 min	20 min
	Set MUTE-TIME	1 min	1 – 2 min	1 min

Menu item	Submenu	Default value	Value range	Resolution	
SETUP CLEANING PGM					
CLEANING Times	Rinsing TIME	15 min	5 – 30 min	1 min	
	Hotrinse TIME	15 min	15 – 30 min	1 min	
	Disinfection TIME	10 min	10 – 20 min	1 min	
	Rinsing Free TIME	CPU1: DIP switch array 1, SW8 set to OFF (Test flow 800 ml/min)	3 min	3 – 10 min	1 min
			for CDS: 5 min	5 – 10 min	1 min
		CPU1: DIP switch array 1, SW8 set to ON (Test flow 500 ml/min)	4 min	4 – 10 min	1 min
			for CDS: 6 min	6 – 10 min	1 min
	Hot-Disinf TIME	10 min	10 – 20 min	1 min	
	Mandatory Rinse TIME	CPU1: DIP switch array 1, SW8 set to OFF (Test flow 800 ml/min)	15 min	15 – 30 min	1 min
			for ON-LINE-HDF: 20 min	20 – 30 min	1 min
		for ONLINE ^{plus} ™: 17 min	17 min	17 – 30 min	1 min
			CPU1: DIP switch array 1, SW8 set to ON (Test flow 500 ml/min)	15 min	15 – 30 min
	CITRO-Mandat-Ri-Time	CPU1: DIP switch array 1, SW8 set to OFF (Test flow 800 ml/min)	10 min	10 – 25 min	1 min
			for ON-LINE-HDF: 20 min	20 – 25 min	1 min
for ONLINE ^{plus} ™: 17 min		17 min	17 – 25 min	1 min	
		CPU1: DIP switch array 1, SW8 set to ON (Test flow 500 ml/min)	10 min	10 – 25 min	1 min
INTEGRATED-HR Time	for ON-LINE-HDF: 20 min	20 min	20 – 25 min	1 min	
		for ONLINE ^{plus} ™: 20 min	20 – 25 min	1 min	
	20 min	20 min	20 – 25 min	1 min	
		20 min	20 – 25 min	1 min	

Continued on the next page

Menu item	Submenu	Default value	Selectable options
SETUP CLEANING PGM (Continued)			
Pgm COMBINATION only for 4008 E/B	RINSE Pgm	PGM 1: -R-	PGM 1: -R- PGM 2: -R- endless
	HOTRINSE Program	PGM 1: -F-HR-C-	PGM 1: -F-HR-C- PGM 2: -F-HR- PGM 3: -IHR- PGM 4: -IHR-C-
	DISINFECTION Pgm	PGM 2: -F-HDIS-M-	PGM 1: -F-D-M- PGM 2: -F-HDIS-M- PGM 3: -F-D-M-HR- PGM 4: -F-HDIS-M-HR-
DEFAULT Cleaning Pgm only for 4008 E/B		PGM 1: -R-	PGM 1: -R- PGM 2: -R- endless PGM 1: -F-HR-C- PGM 2: -F-HR- PGM 3: -IHR- PGM 4: -IHR-C- PGM 1: -F-D-M- PGM 2: -F-HDIS-M- PGM 3: -F-D-M-HR- PGM 4: -F-HDIS-M-HR-

Menu item	Submenu	Default value	Selectable options	
SETUP DILUTION	canister	canister 1+34	canister 1+34 1+35.83 (NaCl 20) 1+35.83 (NaCl 26) 1+35.83 (Belgium) canister 1+44 C canister 1+44 ACF VARIABLE SETTING	
	CDS	CDS 1+34	CDS 1+34 CDS 1+44 C CDS 1+44 ACF	
	VARIABLE SETTING	Default value	Value range	Resolution
		-	0.800 – 2.500	0.001
		-	30.000 – 45.000	0.001
		-	25 – 45	1
		-	25 – 80	1

Menu item	Submenu	Default value	Selectable options
HDF-DILUTION only for ON-LINE-HDF (option)		HDF-PRE-dilution	HDF-PRE-dilution HDF-POST-dilution

Menu item	Submenu	Default value	Value range	Resolution
SET CONDUCT. LIMIT	Cd Limit: 12.8 mS/cm	12.8 mS/cm	12.8 – 14.0 mS/cm	0.1 mS/cm

Menu item	Submenu	Default value	Selectable options
INFO SOUND (C-PGM)		Info-Sound: ON	Info-Sound: ON Info-Sound: OFF

Menu item	Submenu	Default value	Value range	Resolution
SET DIAL PARAMETERS				
SET Flow Parameter	Flow[ml/min]: 500	500 ml/min	300 / 500 / 800 ml/min or value set in Dial	
SET Temp. Parameter	Temp.[°C]: 37.0	37 °C	35 – 39 °C or value set in Dial	0.5 °C
SET Na/Bic Parameter	Base Na+ 135mmol	135 mmol	125 – 150 mmol or value set in Dial	1 mmol
	Prescr. Na+ 135mmol	135 mmol	125 – 150 mmol (±13 mmol around the basic value)	1 mmol
	Bicarbonate ±0mmol	0 mmol	–8 to +8 mmol or value set in Dial	1 mmol
	Limit Na/Base: 13 mmol only for 4008 H/S	13 mmol	0 – 13 mmol however prescribed Na ⁺ , Base Na ⁺	1 mmol

Menu item	Submenu	Default value	Selectable options
DIALYSIS TIME only for 4008 E/B		Effect. dialysis time	Effect. dialysis time UF time

Menu item	Submenu	Default value	Selectable options
CALC.CUMUL.BLOOD-VOL		during seq DIAL: YES	during seq DIAL: YES during seq DIAL: NO

Menu item	Submenu	Default value	Selectable options
HAEMOGLOBIN UNIT only for BVM (option) and 4008		g/dl	g/dl mmol/l

Menu item	Submenu	Default value	Selectable options	
OCM SETTINGS only for OCM (option) and 4008 H/S	OCM MEASUREMENT	OCM Measurement: OFF	OCM Measurement: OFF OCM Measurement: ON	
	OCM MEASURE DEL.TIME		Default value	Value range
		4008 H with advanced hydraulics: 15 sec		1 – 70 sec
		4008 H with ONLINE ^{plus} ™: 65 sec		1 – 70 sec
		4008 S with advanced hydraulics: 18 sec		1 – 70 sec
4008 S with ONLINE ^{plus} ™: 67 sec		1 – 70 sec		
OCM KT/V WARNLEVEL		85 %	0 – 99 %	

Menu item	Submenu	Default value	Selectable options
AUTOM. SN-START		autom. SN: OFF	autom. SN: OFF autom. SN: ON

Menu item	Submenu	Default value	Selectable options
ACTIV. MONIT_NTC109		MONIT_NTC109: YES	MONIT_NTC109: YES MONIT_NTC109: NO

Menu item	Submenu	Default value	Selectable options
ACTIV. STD UF-DATA		std UF-DATA: NO	std UF-DATA: NO std UF-DATA: YES

Menu item	Submenu	Default value	Value range	Resolution
SET STD. PRIME-TIME	Prime-Time = 2min	2 min	1 – 5 min	1 min

Menu item	Submenu	Default value	Selectable options
SOUND I/O-SWITCH		I/O-Warnsound: ON	I/O-Warnsound: ON I/O-Warnsound: OFF

Menu item	Submenu	Default value	Selectable options
SET KEY-CLICK only for 4008 H/S		key-click: ON	key-click: ON key-click: OFF

Menu item	Submenu	Default value	Selectable options
BPR/UFR-WARNING		BPR/UFR-Warning: ON	BPR/UFR-Warning: ON BPR/UFR-Warning: OFF

Menu item	Submenu	Default value	Value range	Resolution
SET RINSE-VOLUME	RINSE-VOL: 1000 ml	1000 ml	0 – 5000 ml	100 ml

Menu item	Submenu	Default value	Selectable options
T1-TEST AUTOSTART		T1-T. Autostart: OFF	T1-T. Autostart: OFF T1-T. Autostart: ON

Menu item	Submenu	Default value	Value range	Resolution
ONLINE plus SETTINGS only for ONLINE ^{plus} ™ (option)				
ONLINE plus HD	SET UF-Volume F/R	0 ml	0 – 1000 ml	100 ml
	SET Rinsing Volume	1000 ml	0 – 5000 ml	100 ml
ONLINE plus HDF	SET UF-Volume F/R	500 ml	0 – 1000 ml	100 ml
	SET Rinsing Volume	1000 ml	0 – 5000 ml	100 ml
	SET Substit.-Volume	12 l	0 – 210 l	1 l
ONLINE plus HF	SET UF-Volume F/R	1000 ml	0 – 5000 ml	100 ml
	SET Rinsing Volume	1000 ml	0 – 5000 ml	100 ml
	SET Substit.-Volume	20 l	0 – 210 l	1 l
ONLINE plus MISC.	SET Reinf.-Volume	240 ml	90 – 480 ml	30 ml

Menu item	Submenu	Default value	Selectable options
SET CENTRAL-DELIVERY		NO central-delivery	NO central-delivery central Bic central Acid central Acid + Bic centr acetate-supply

Menu item	Submenu	Default value	Selectable options
AutoOFF after AutoON		OFF	OFF ON

Menu item	Submenu	Default value	Selectable options
Init. CAMUS-baudrate		2400 baud	2400 baud 9600 baud

Menu item	Adjustment
STORE DEFAULT VALUES	Press VERRIDE only for 4008 E/B Press ALARMTONE MUTE only for 4008 H/S

6.2 Overview

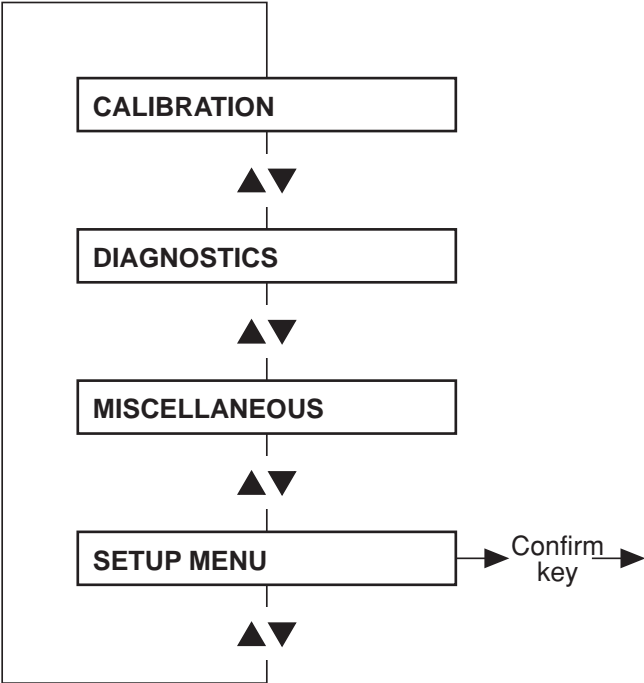

6.3 Main menu 4008 E/B

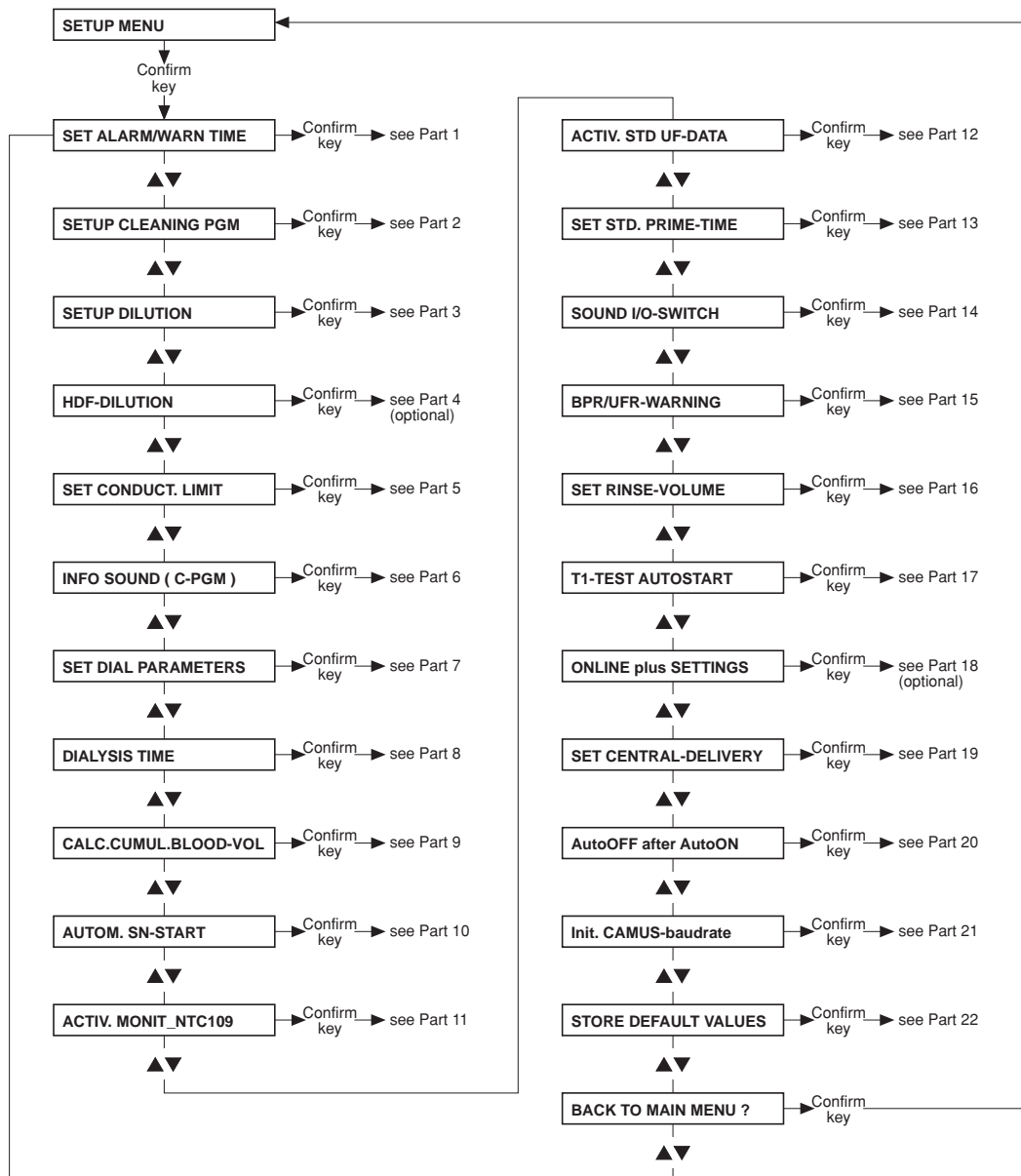

- **Part 1: Setting the alarm and warning time**

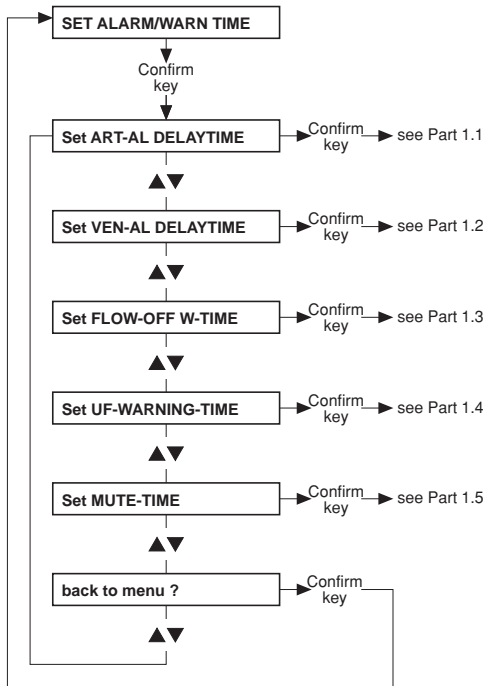

- **Part 1.1: Setting the delay time of the arterial alarm**

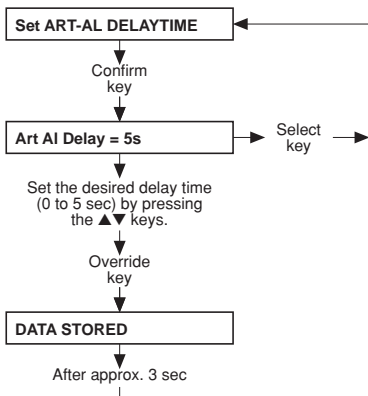

- **Part 1.2: Setting the delay time of the venous alarm**

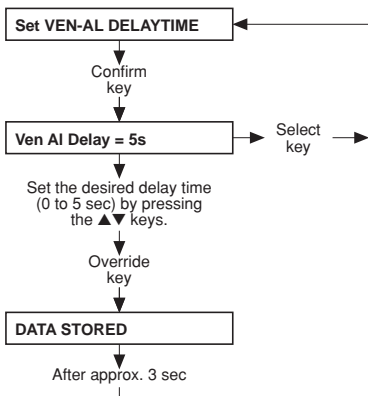

- **Part 1.3: Setting the flow-off warning time**

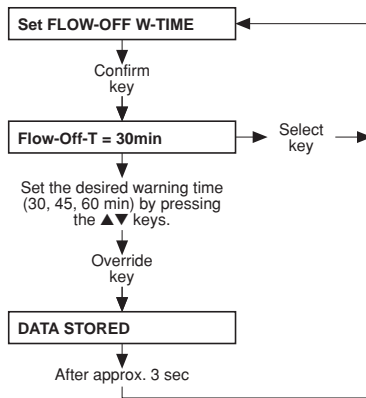

- **Part 1.4: Setting the UF warning time**

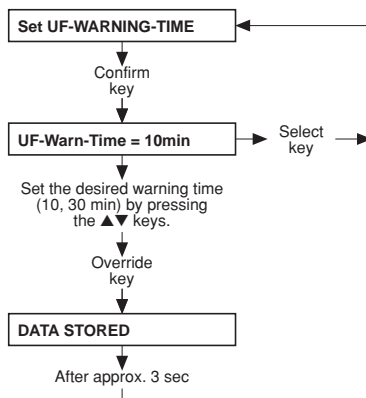

- **Part 1.5: Setting the mute time**

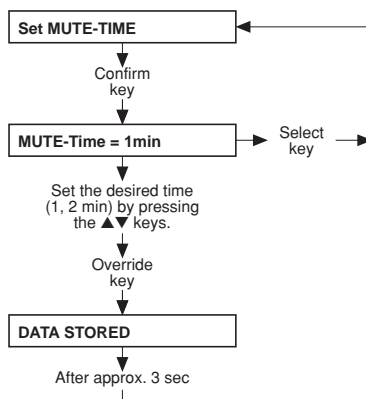

- **Part 2: Setting up the cleaning program**

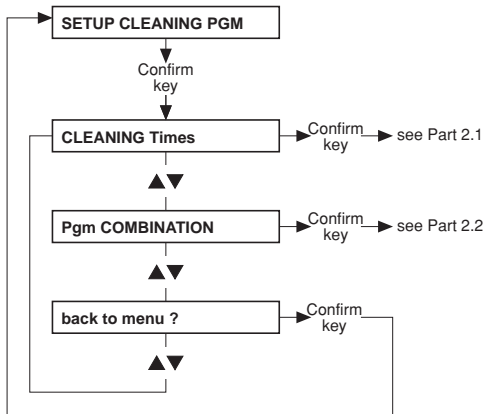

- **Part 2.1: Cleaning times**



Note

The default values and the adjustable range for the cleaning times are not indicated, as they depend on the particular system options.

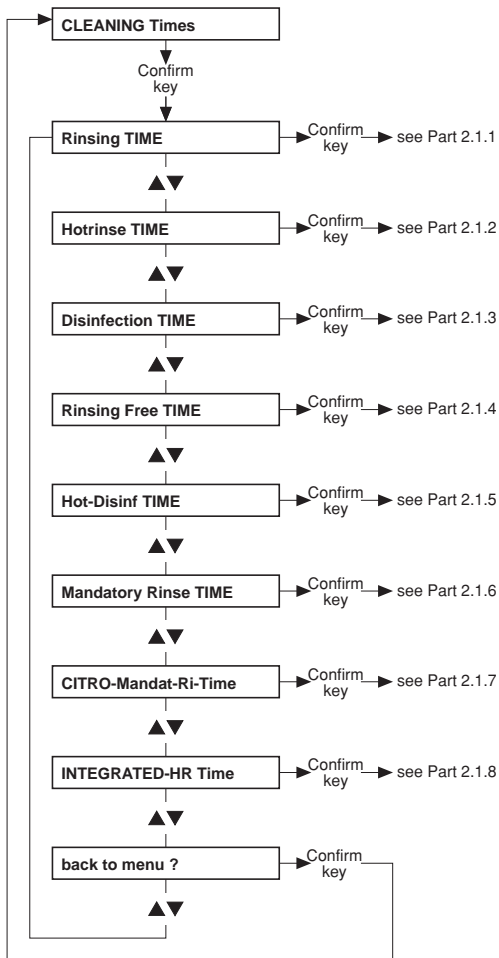

- **Part 2.1.1: Rinsing time**

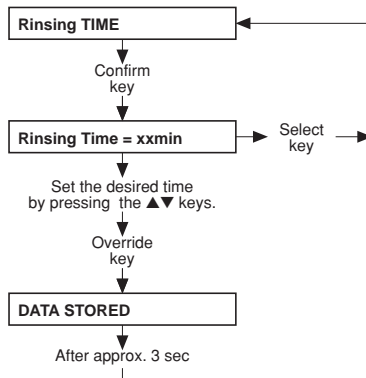

- **Part 2.1.2: Hot rinsing time**

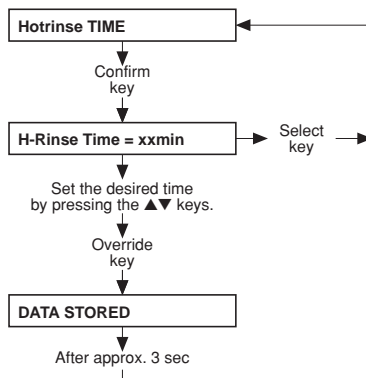

- **Part 2.1.3: Disinfection time**

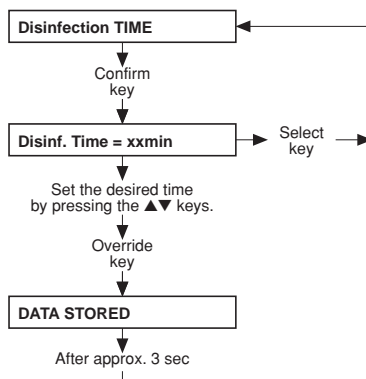

- **Part 2.1.4: Rinsing free time**

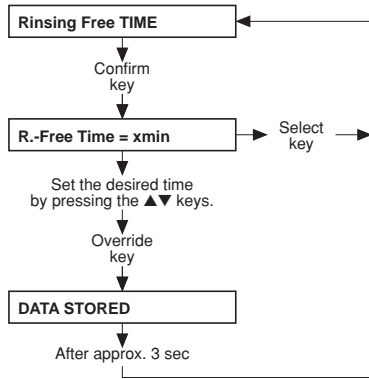

- **Part 2.1.5: Hot disinfection time**

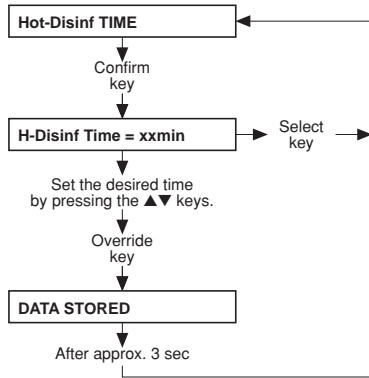

- **Part 2.1.6: Mandatory rinse time**

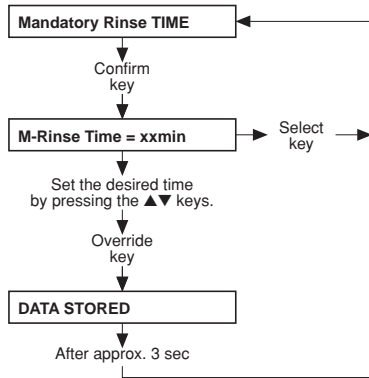

- **Part 2.1.7: Citro mandatory rinse time**

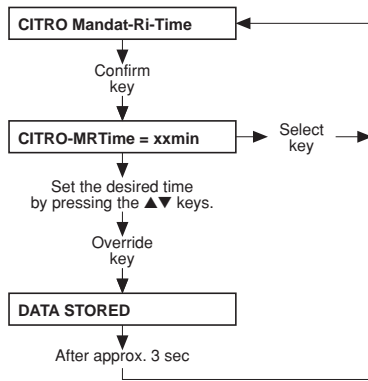

- **Part 2.1.8: Integrated hot rinse time**

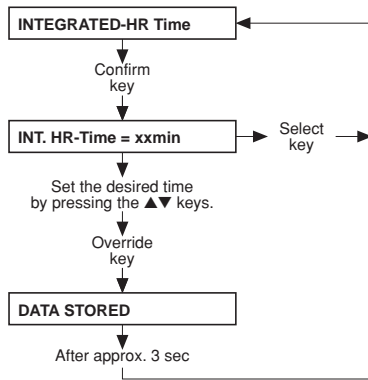

● Part 2.2: Cleaning program combination

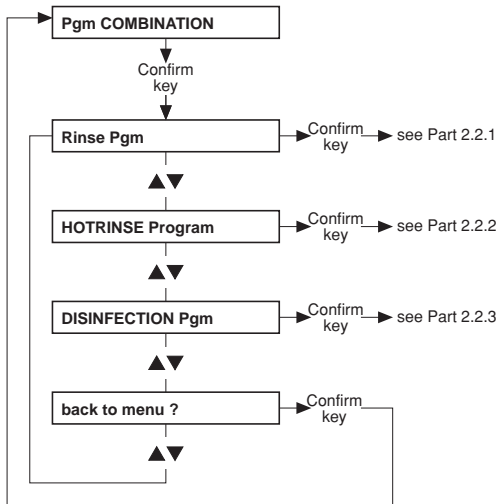

● Part 2.2.1: Rinse program

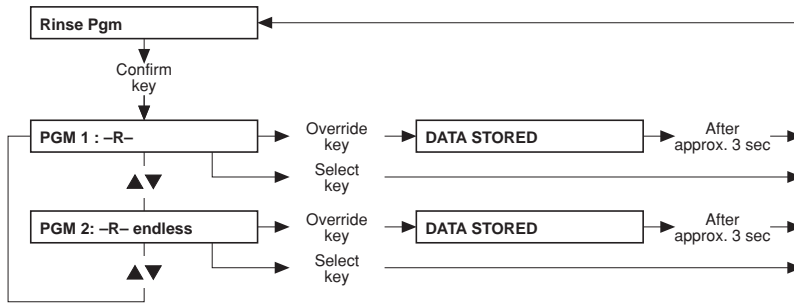

● Part 2.2.2: Hot rinse program

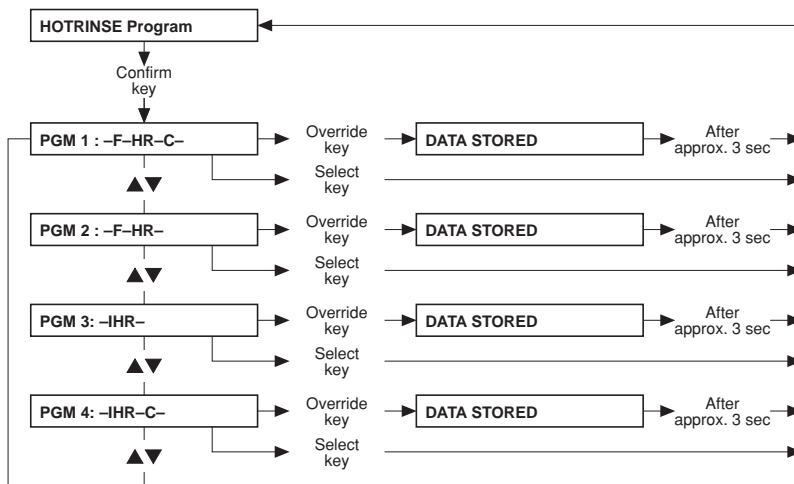

● Part 2.2.3: Disinfection program

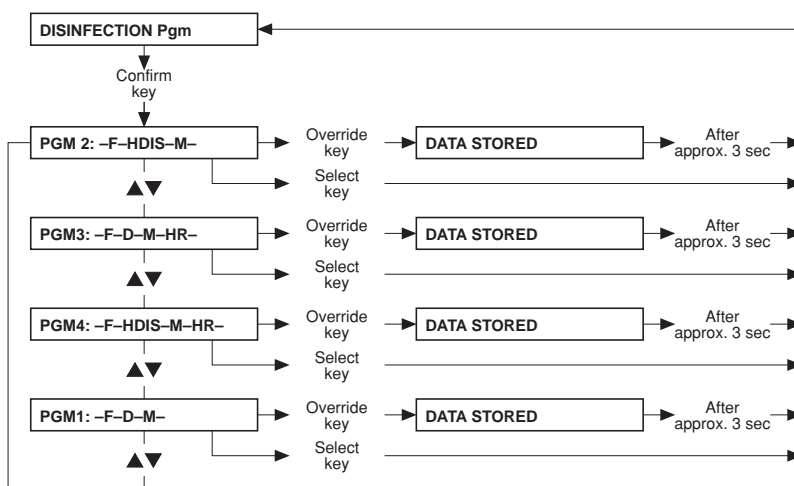

● **Part 3: Mixing ratio with „NO central-delivery“, „central Bic“ (setting → Part 19)**

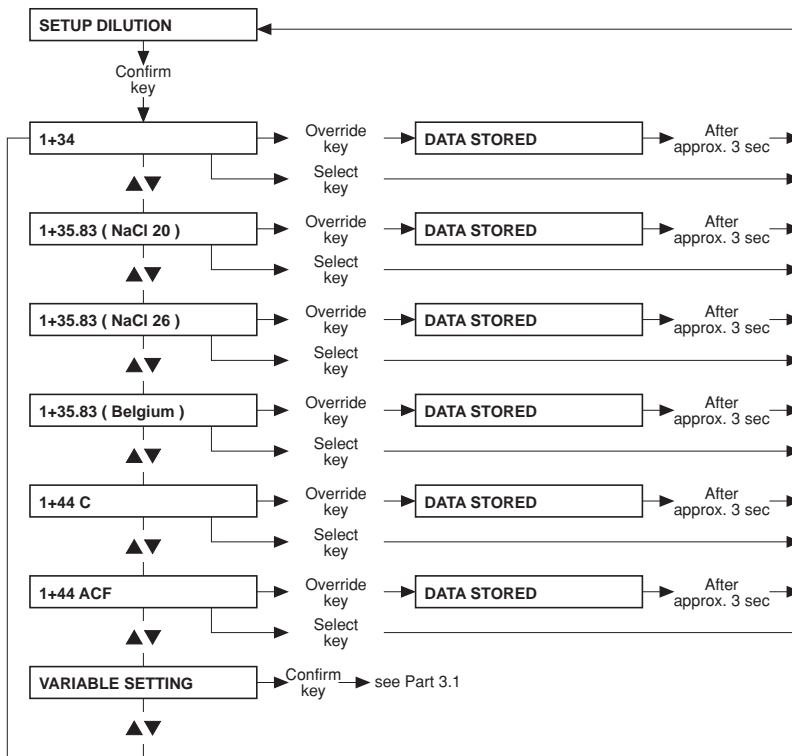

● **Part 3: Mixing ratio with „central Acid“, „central Acid + Bic“ (setting → Part 19)**

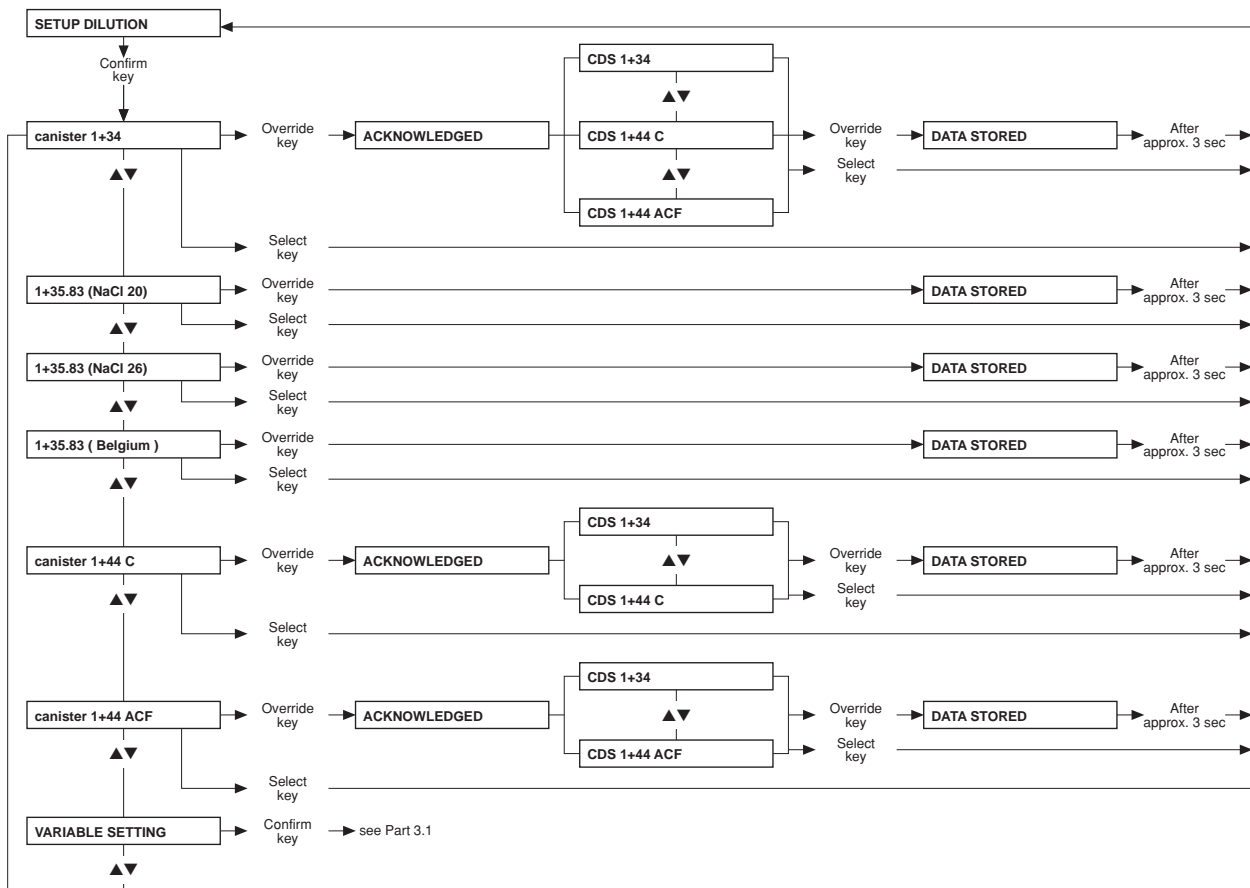

● Part 3: Mixing ratio with „centr acetate-supply“ (setting → Part 19)

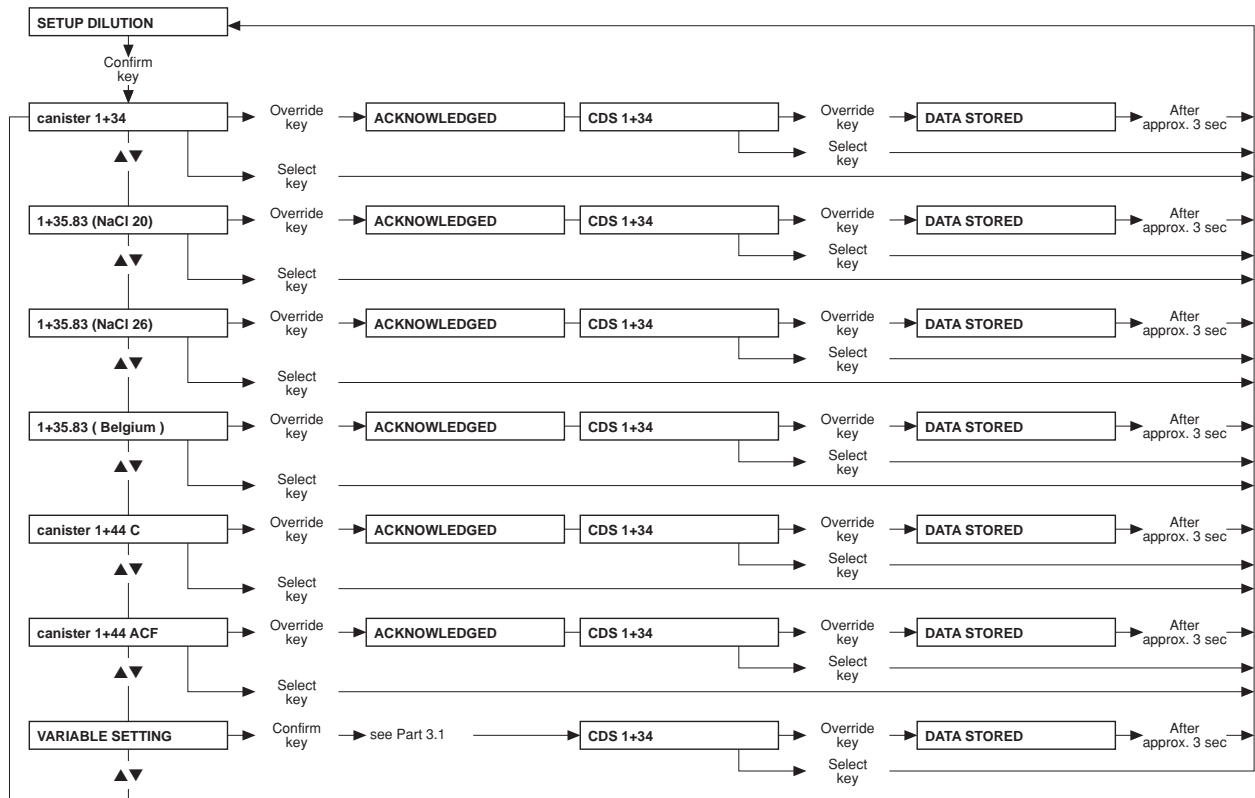

● **Part 3.1: Programmable mixing ratio (dilution)**



Caution

The operator or technician is informed about his duty of care to enter the component parameters and settings correctly or to check them and to set the CD alarm window to the expected conductivity value.

When using the programmable mixing ratio (dilution), make sure to use the right concentrate.

Using a bi**bag**® in combination with the programmable mixing ratio (dilution) is not allowed.

Only enter authorized, programmable mixing ratios (dilutions).

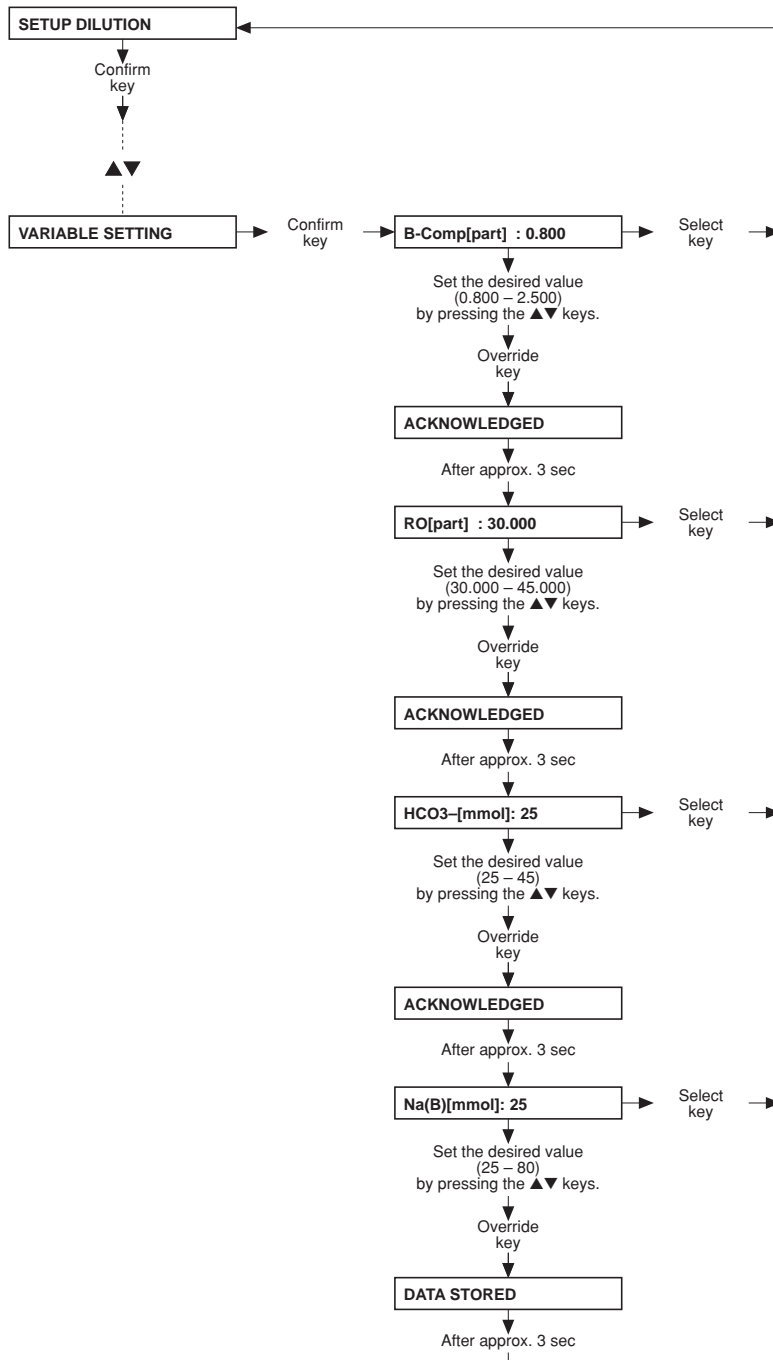

● **Part 4: Setting the HDF dilution – only for ON-LINE-HDF (option)**

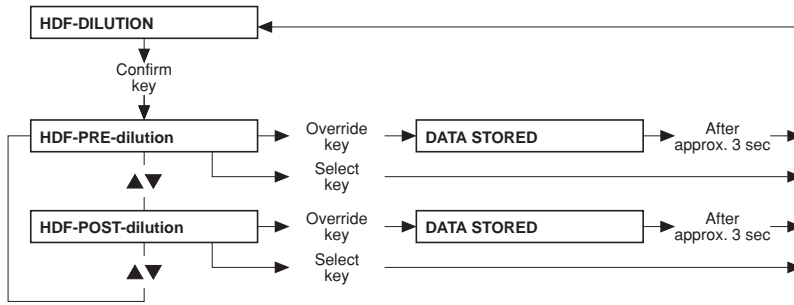

● **Part 5: Setting the conductivity limit**

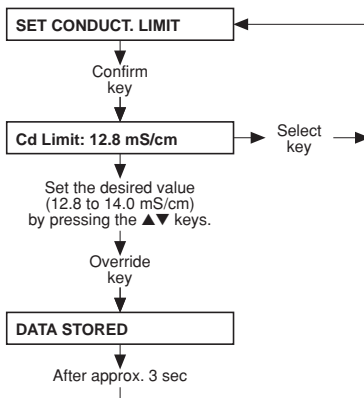

● **Part 6: Infosound cleaning program**

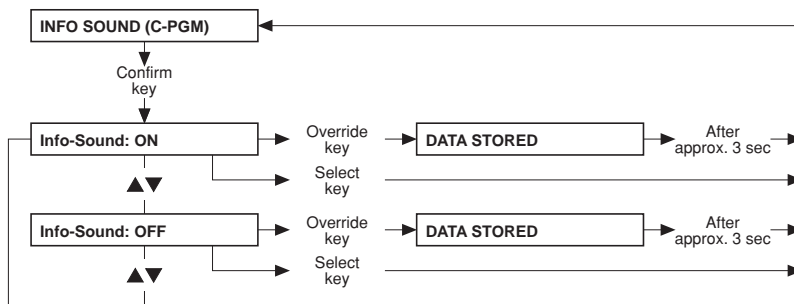

- **Part 7: Setting the dialysis parameters**

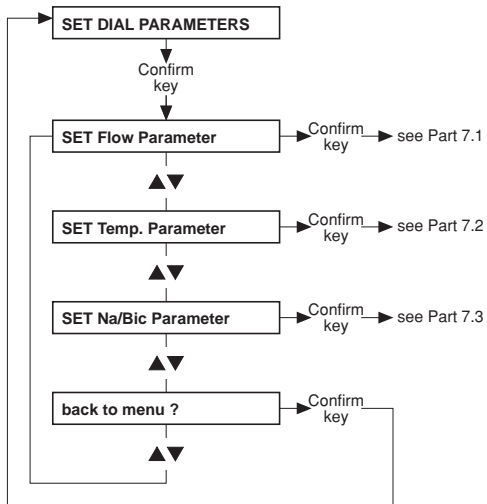

- **Part 7.1: Setting the dialysate flow**

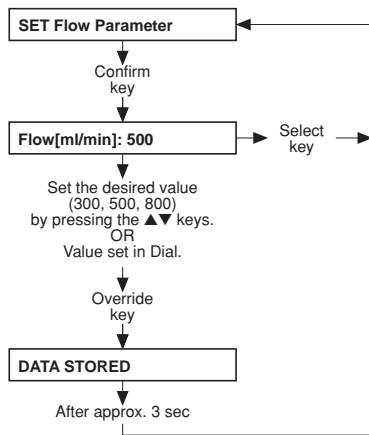

- **Part 7.2: Setting the dialysate temperature**

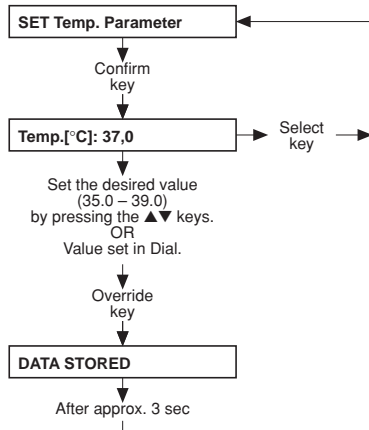

● **Part 7.3: Setting the Na/Bic**

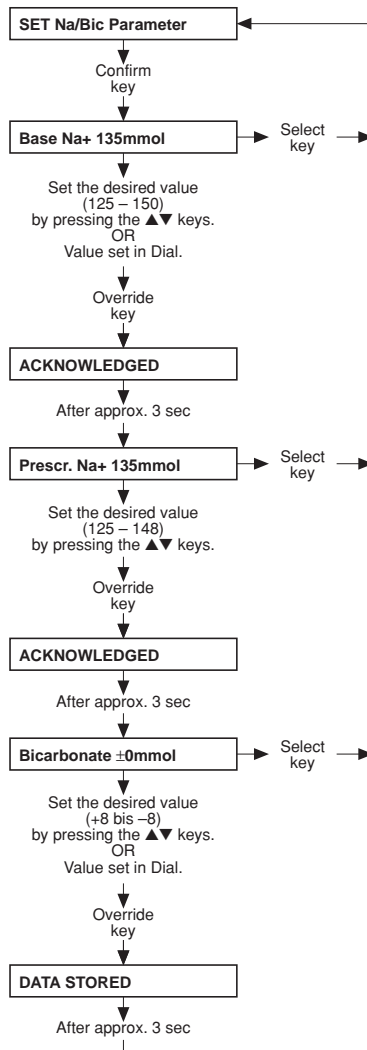

● **Part 8: Dialysis time**

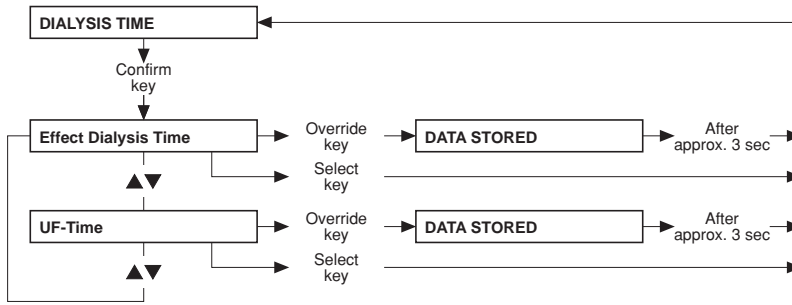

● **Part 9: Cumulated blood volume**

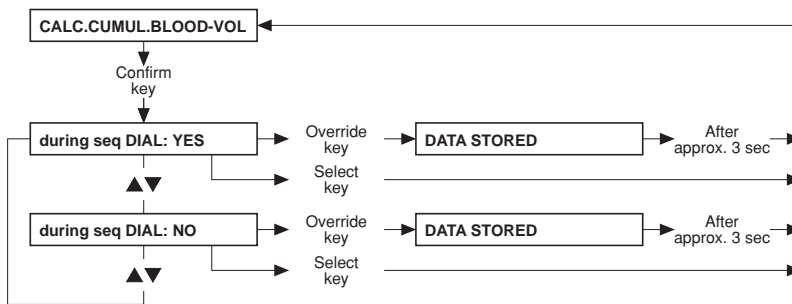

● **Part 10: Automatic Single-Needle start**

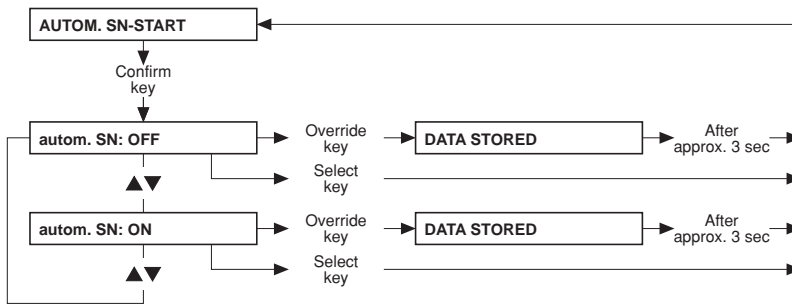

● **Part 11: Activation of Monit_NTC 109**

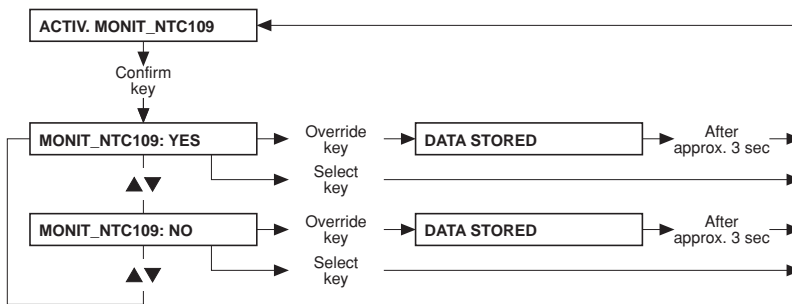

● **Part 12: Activation of standard UF data**

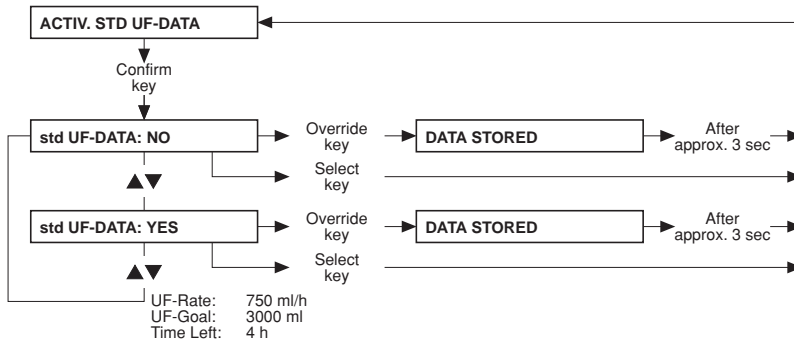

● **Part 13: Setting the priming time**

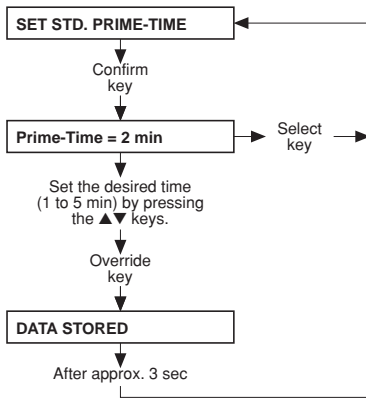

● **Part 14: Warning sound I/O key**

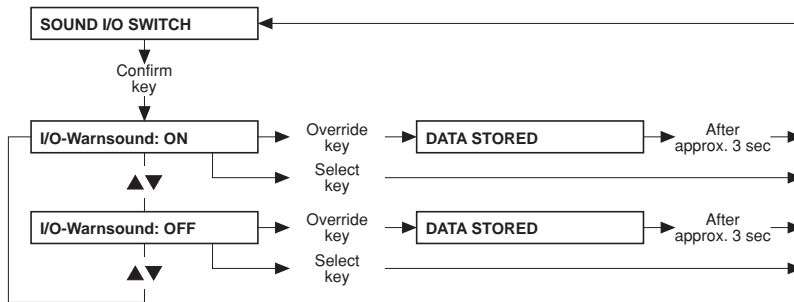

● **Part 15: Setting the BPR/UFR warning**

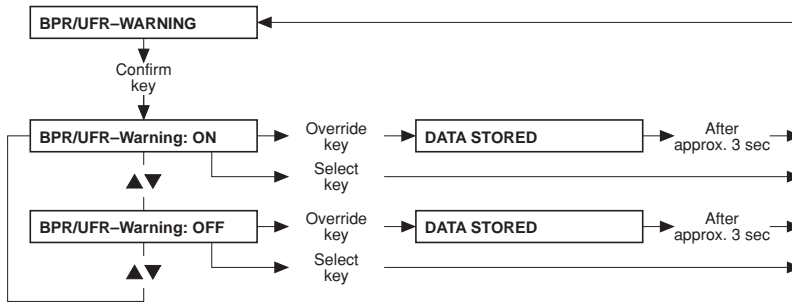

● **Part 16: Setting the rinse volume**

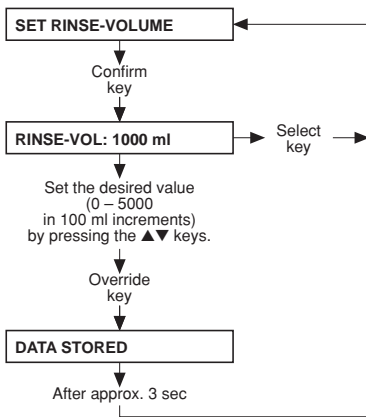

● **Part 17: T1 test autostart**

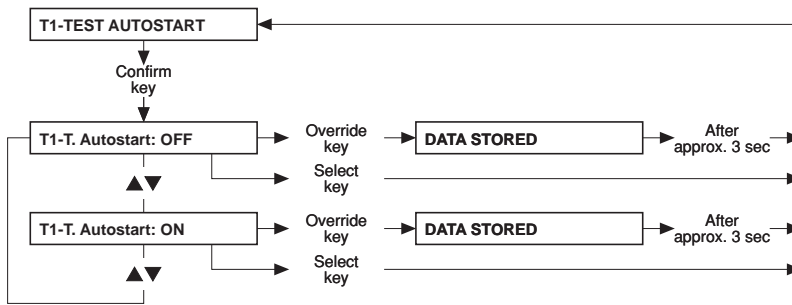

● Part 18: ONLINEplus™ settings – only for ONLINEplus™ (option)

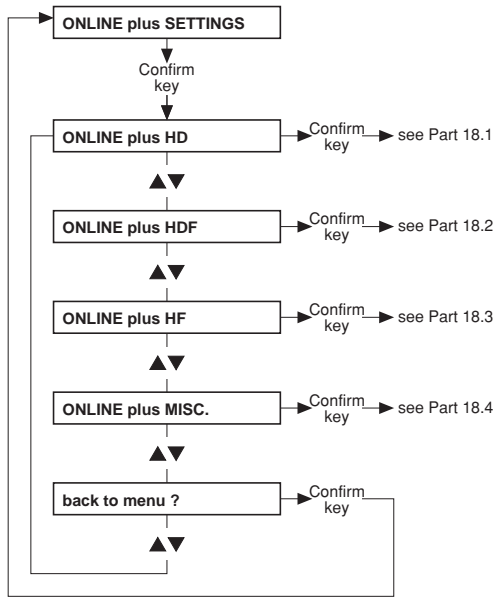

● **Part 18.1: ONLINE^{plus}™ HD**

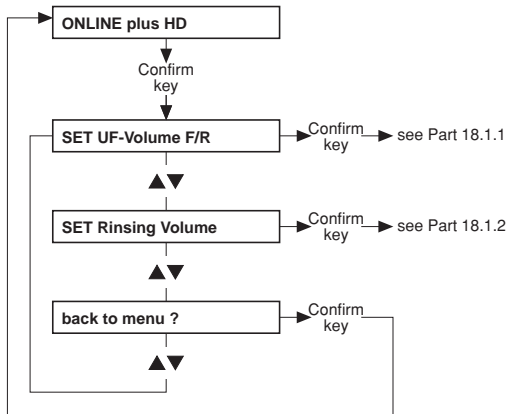

● **Part 18.1.1: Setting the UF volume (filling/rinsing)**

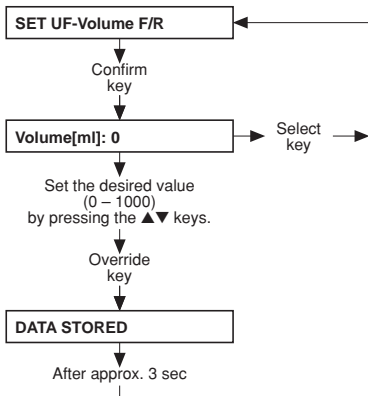

● **Part 18.1.2: Setting the rinse volume**

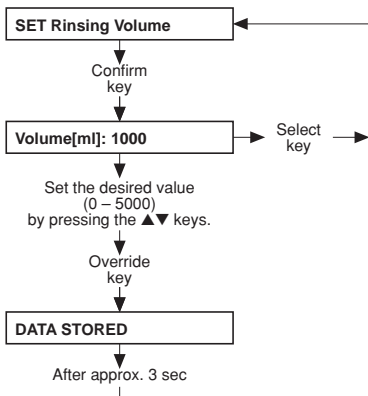

● **Part 18.2: ONLINE^{plus}™ HDF**

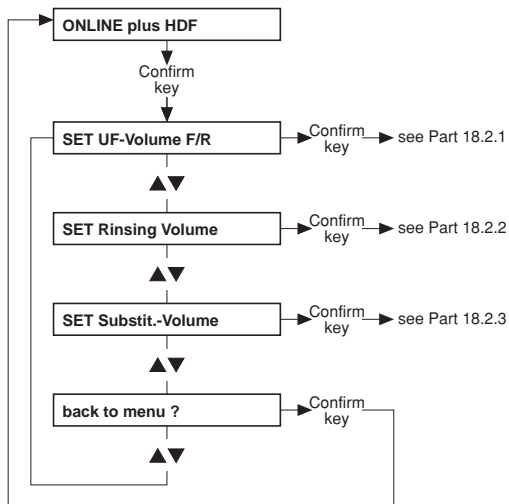

● **Part 18.2.1: Setting the UF volume (filling/rinsing)**

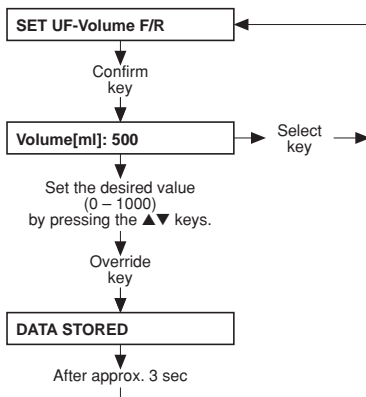

● **Part 18.2.2: Setting the rinse volume**

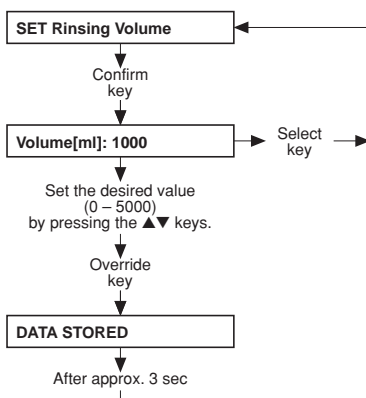

● Part 18.2.3: Setting the substitute volume

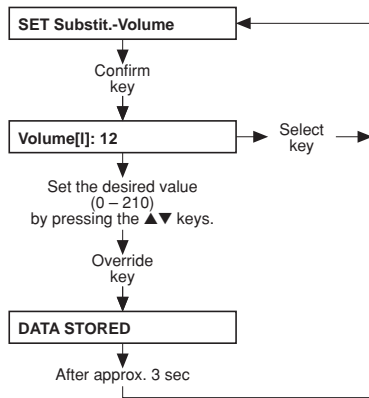

● **Part 18.3: ONLINE^{plus}™ HF**

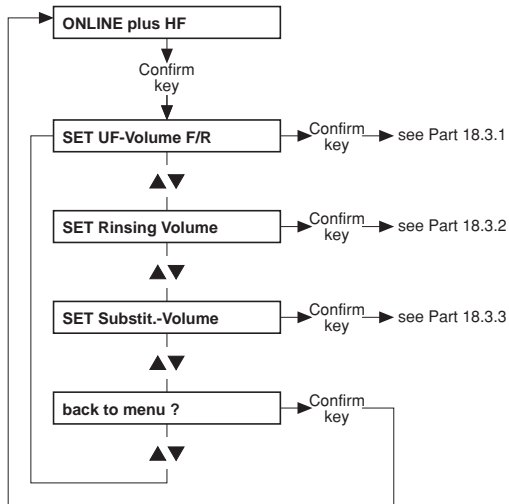

● **Part 18.3.1: Setting the UF volume (filling/rinsing)**

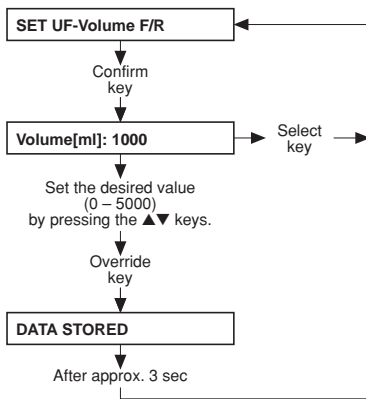

● **Part 18.3.2: Setting the rinse volume**

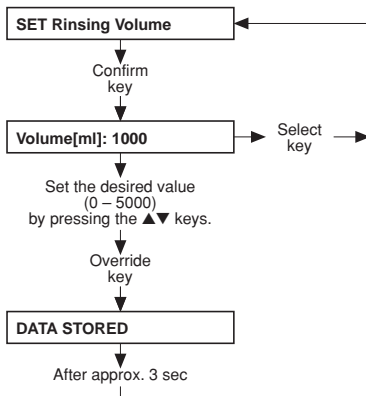

● **Part 18.3.3: Setting the substitute volume**

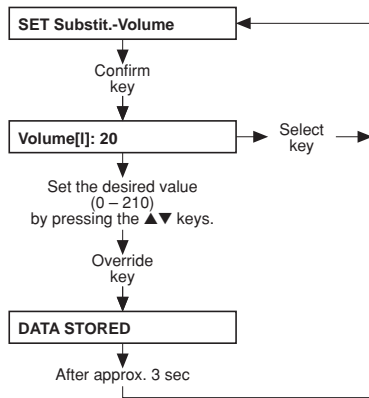

● **Part 18.4: ONLINE^{plus}™ miscellaneous**

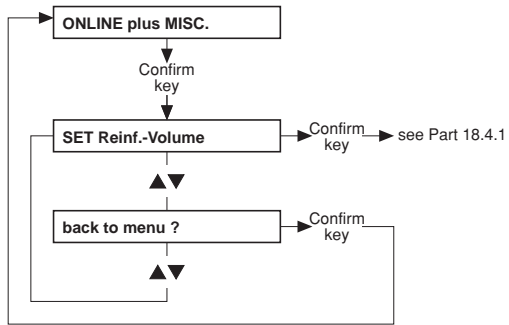

● **Part 18.4.1: Setting the reinfusion volume**

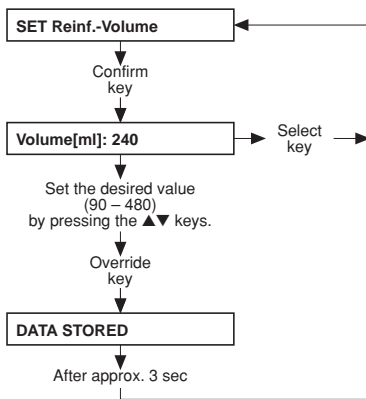

● **Part 19: Setting the parameters for central delivery system**

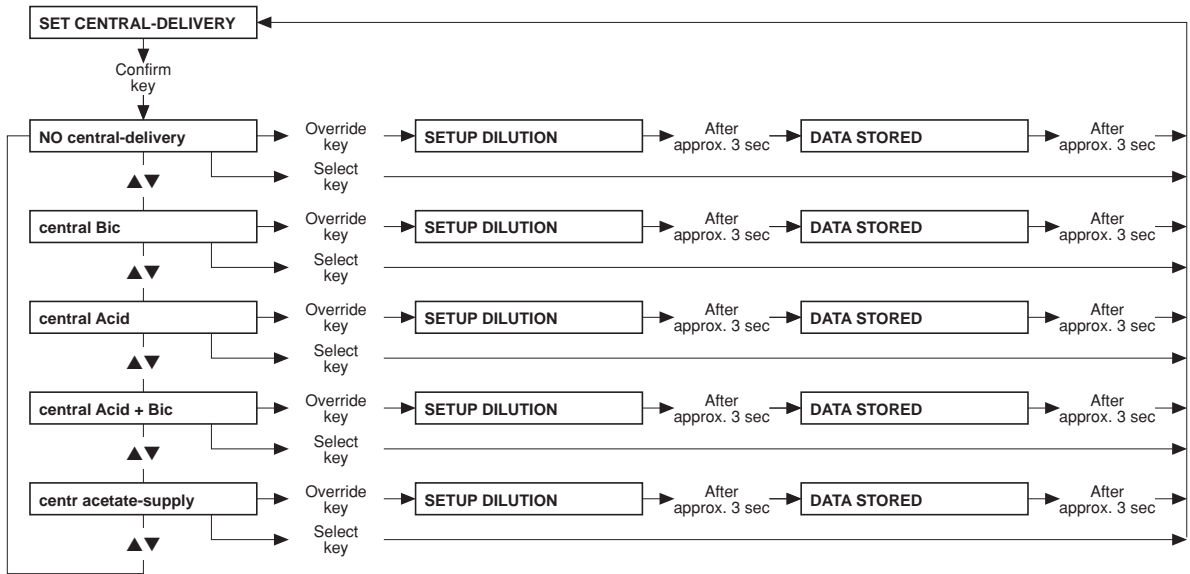

● **Part 20: AutoOFF after AutoON**

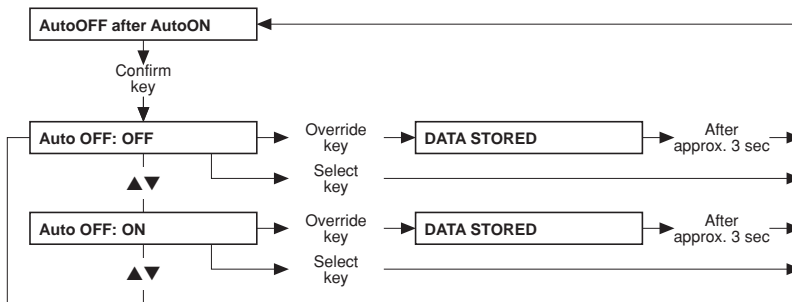

● **Part 21: CAMUS-baudrate**

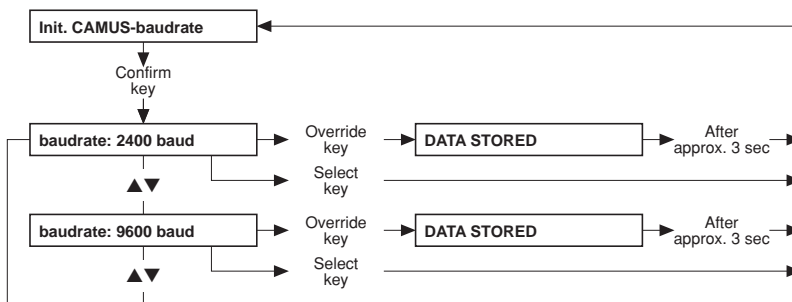

- **Part 22: Storing the default values**

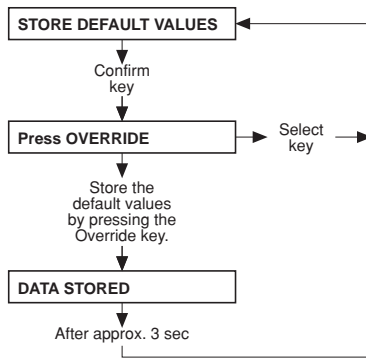

6.4 Main menu 4008 H/S

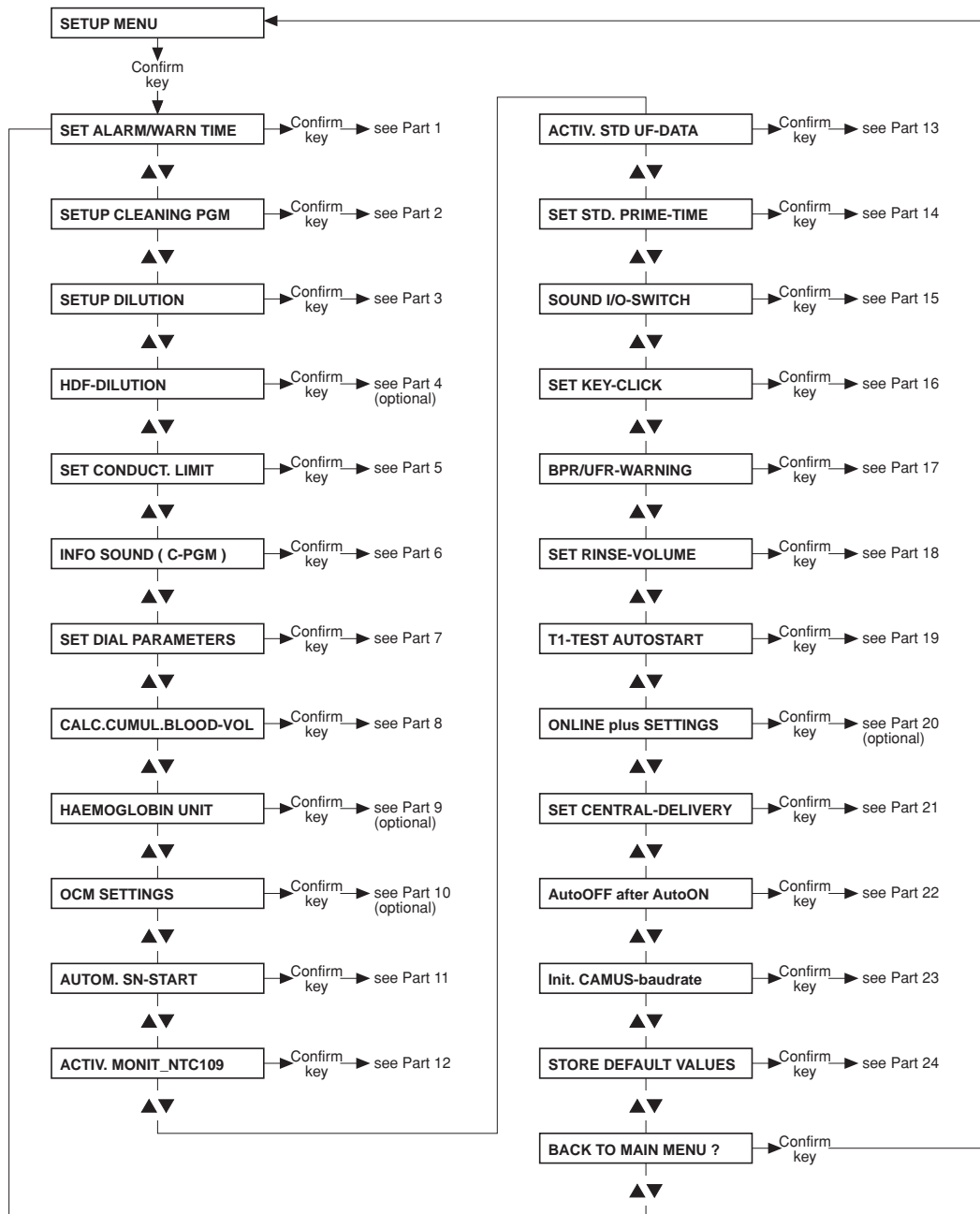

- **Part 1: Setting the alarm and warning time**

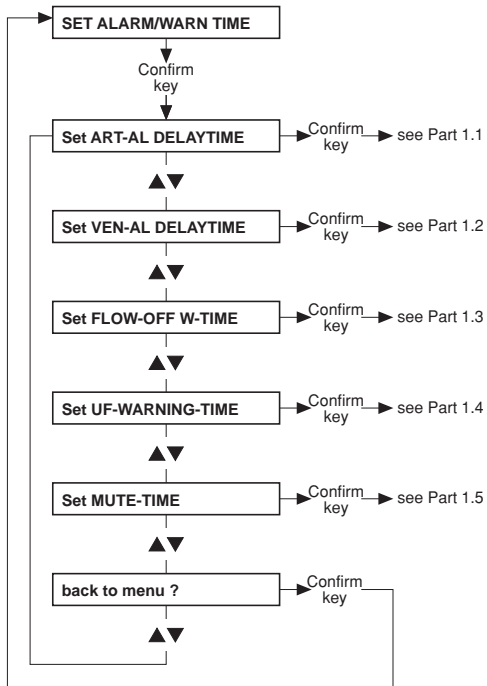

- **Part 1.1: Setting the delay time of the arterial alarm**

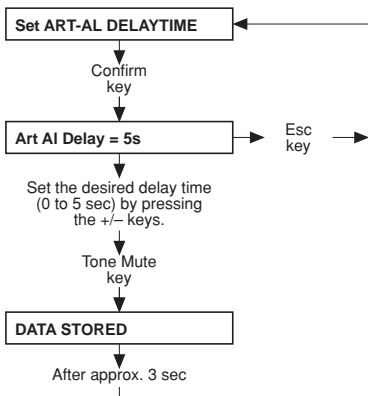

- **Part 1.2: Setting the delay time of the venous alarm**

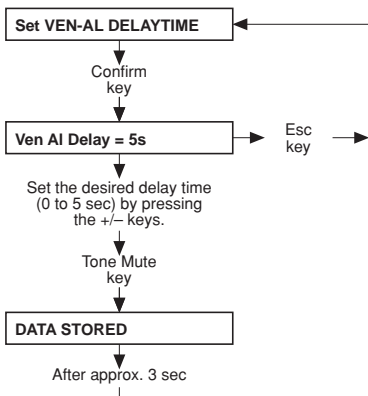

- **Part 1.3: Setting the flow-off warning time**

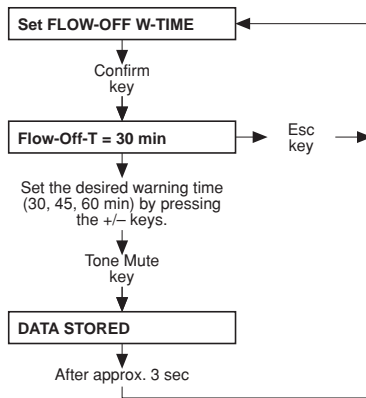

- **Part 1.4: Setting the UF warning time**

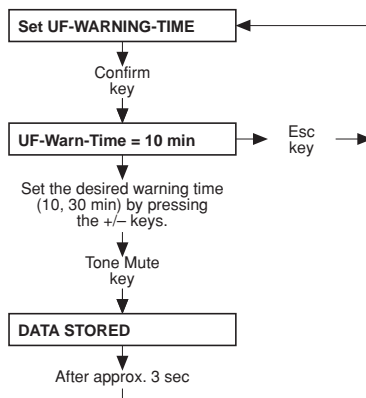

- **Part 1.5: Setting the mute time**

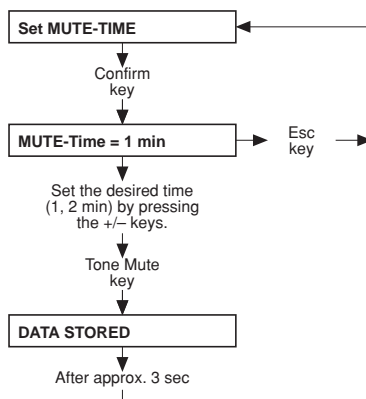

● **Part 2: Setting up the cleaning program**

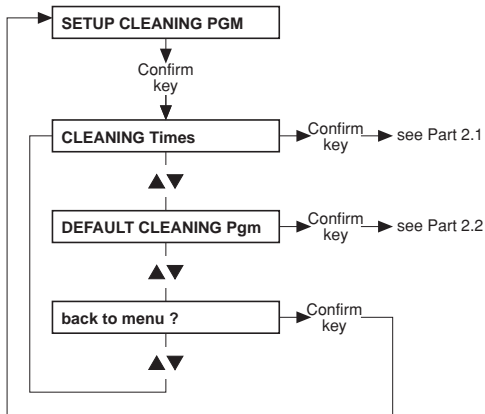

● **Part 2.1: Cleaning times**



Note

The default values and the adjustable range for the cleaning times are not indicated, as they depend on the particular system options.

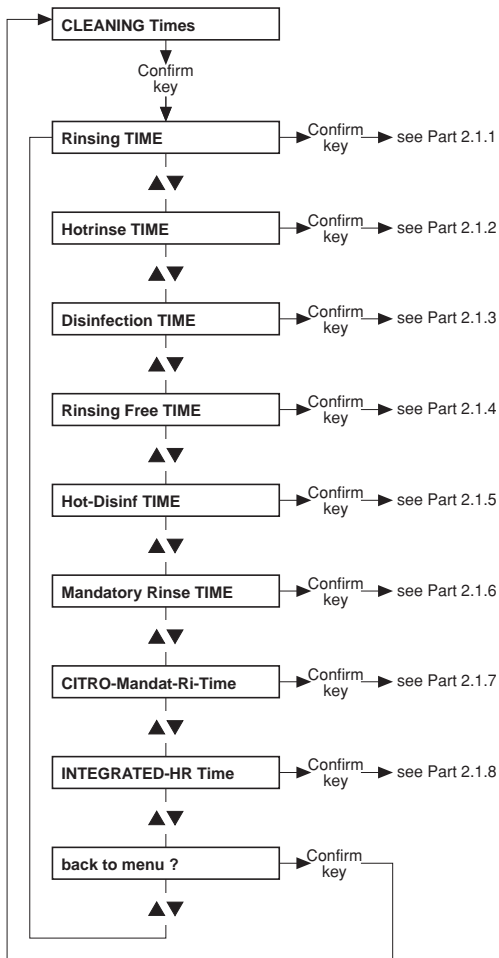

- **Part 2.1.1: Rinsing time**

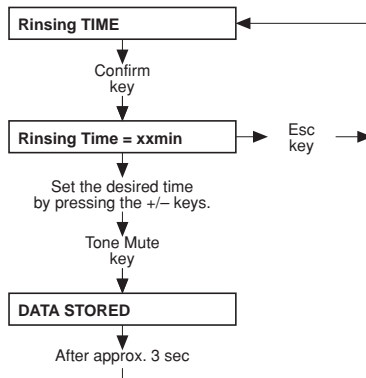

- **Part 2.1.2: Hot rinsing time**

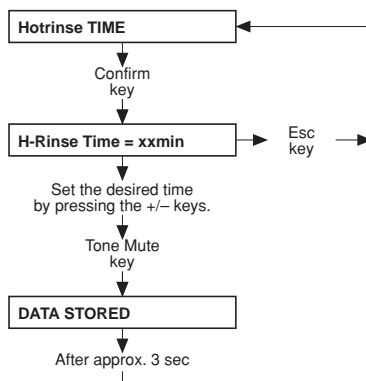

- **Part 2.1.3: Disinfection time**

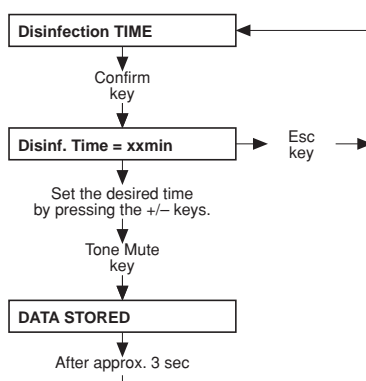

- **Part 2.1.4: Rinsing free time**

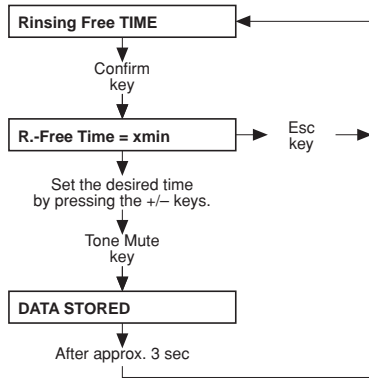

- **Part 2.1.5: Hot disinfection time**

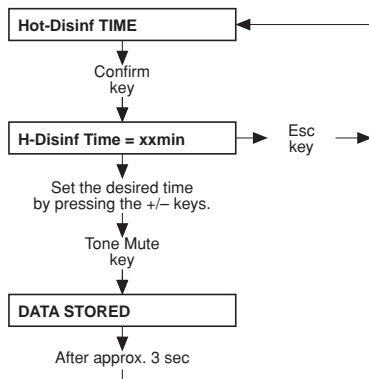

- **Part 2.1.6: Mandatory rinse time**

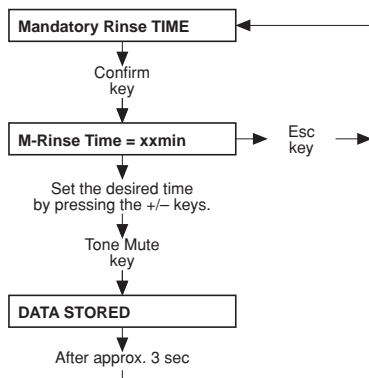

- **Part 2.1.7: Citro mandatory rinse time**

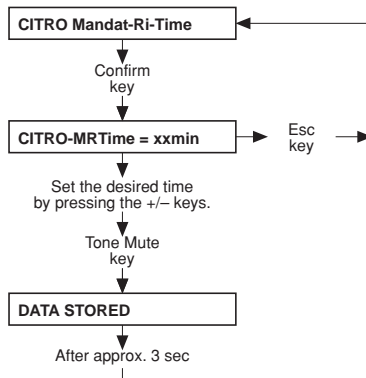

- **Part 2.1.8: Integrated hot rinsing time**

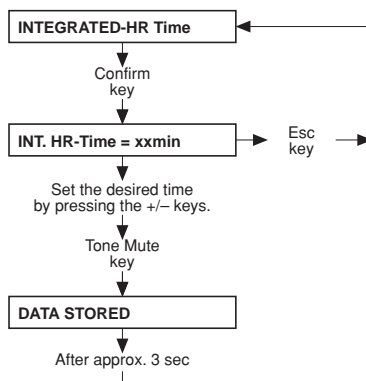

● Part 2.2: Setting the default cleaning program

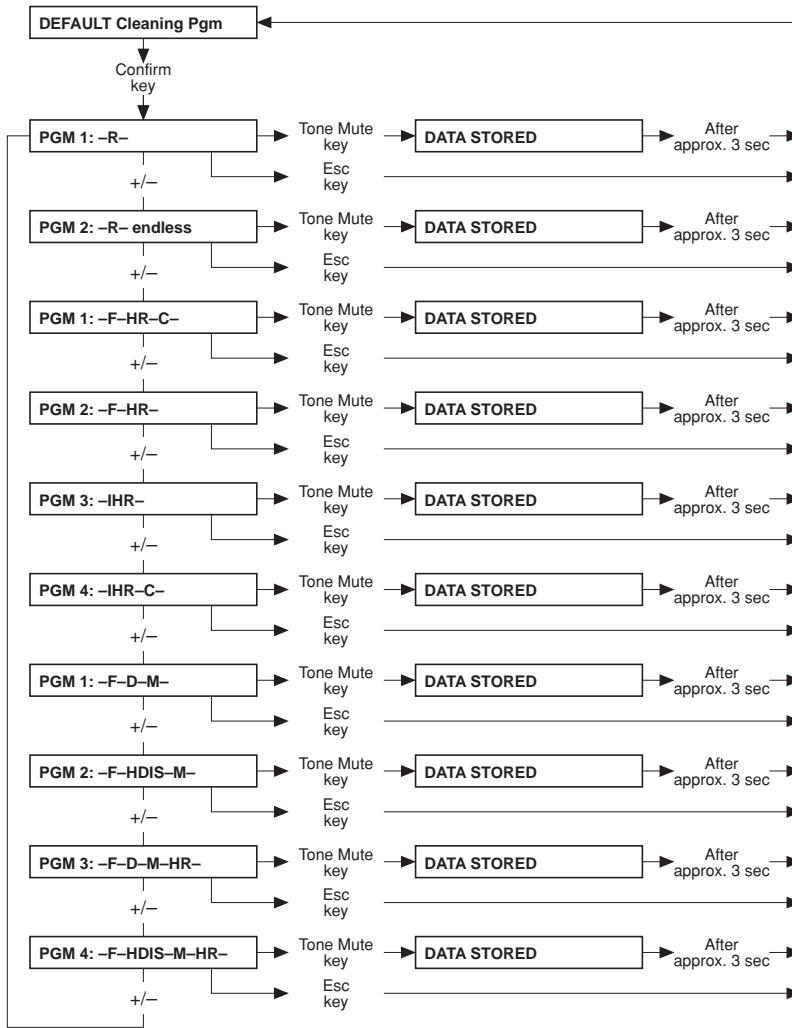

● **Part 3: Mixing ratio with „NO central-delivery“, „central Bic“ (setting → Part 21)**

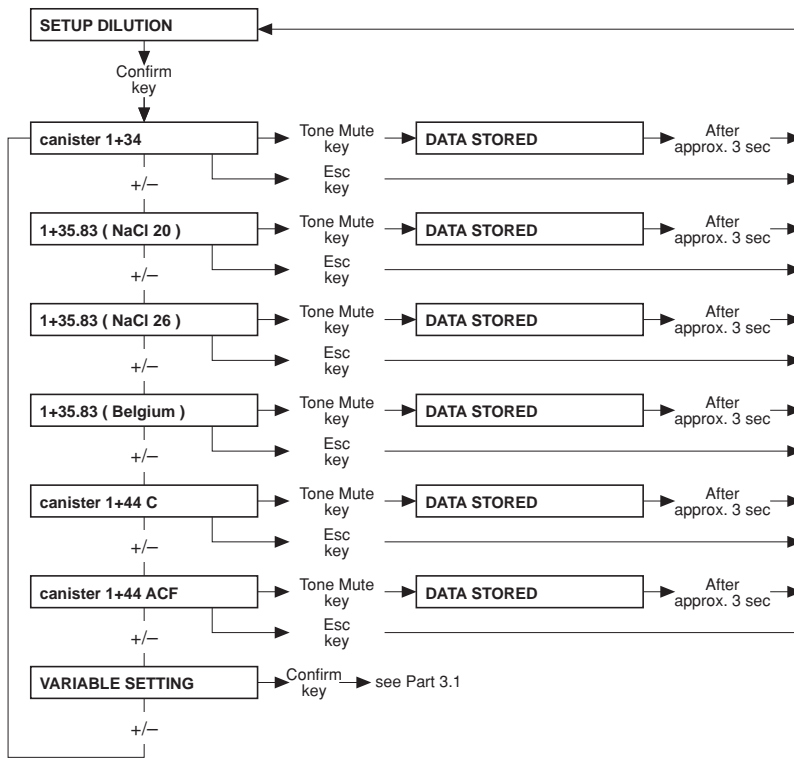

● **Part 3: Mixing ratio with „central Acid“, „central Acid + Bic“ (setting → Part 21)**

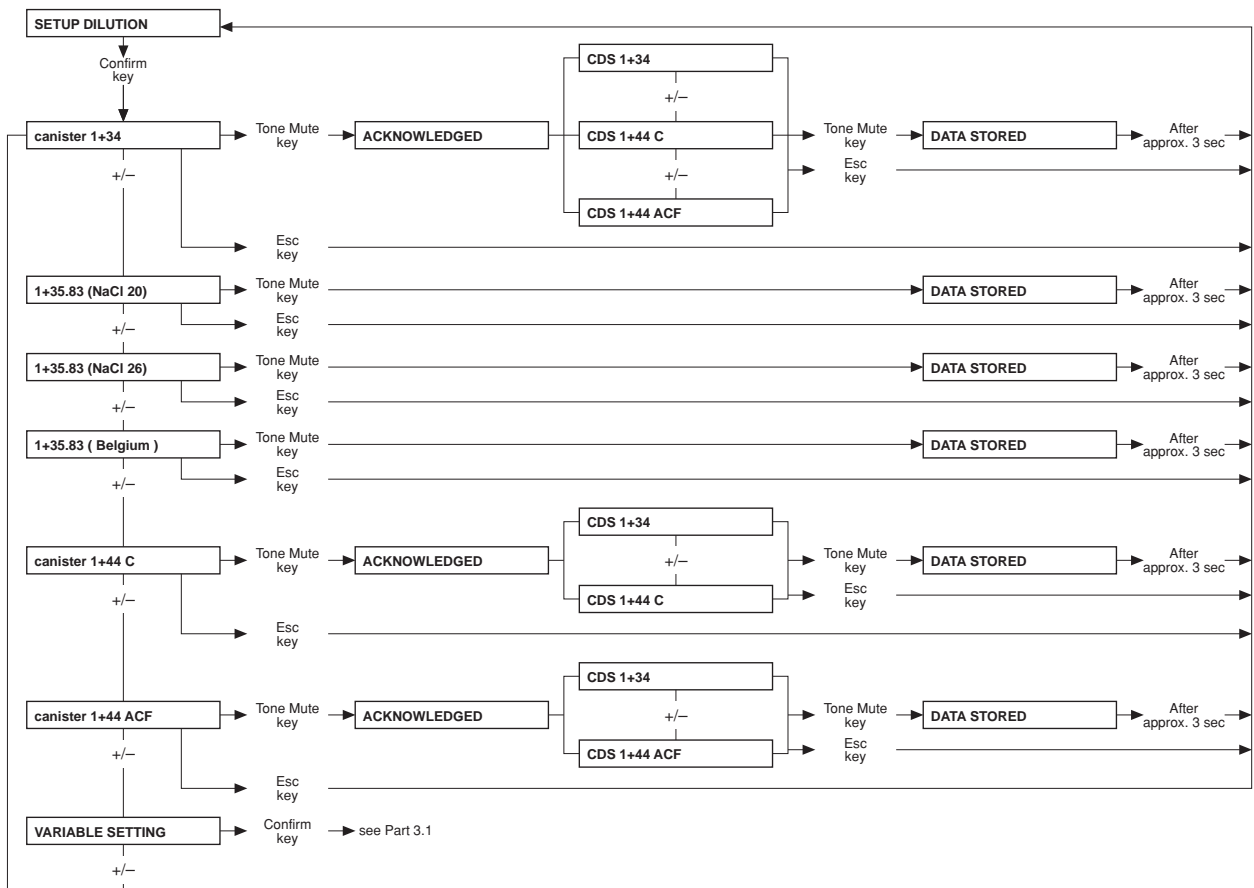

● Part 3: Mixing ratio with „centr acetate-supply“ (setting → Part 21)

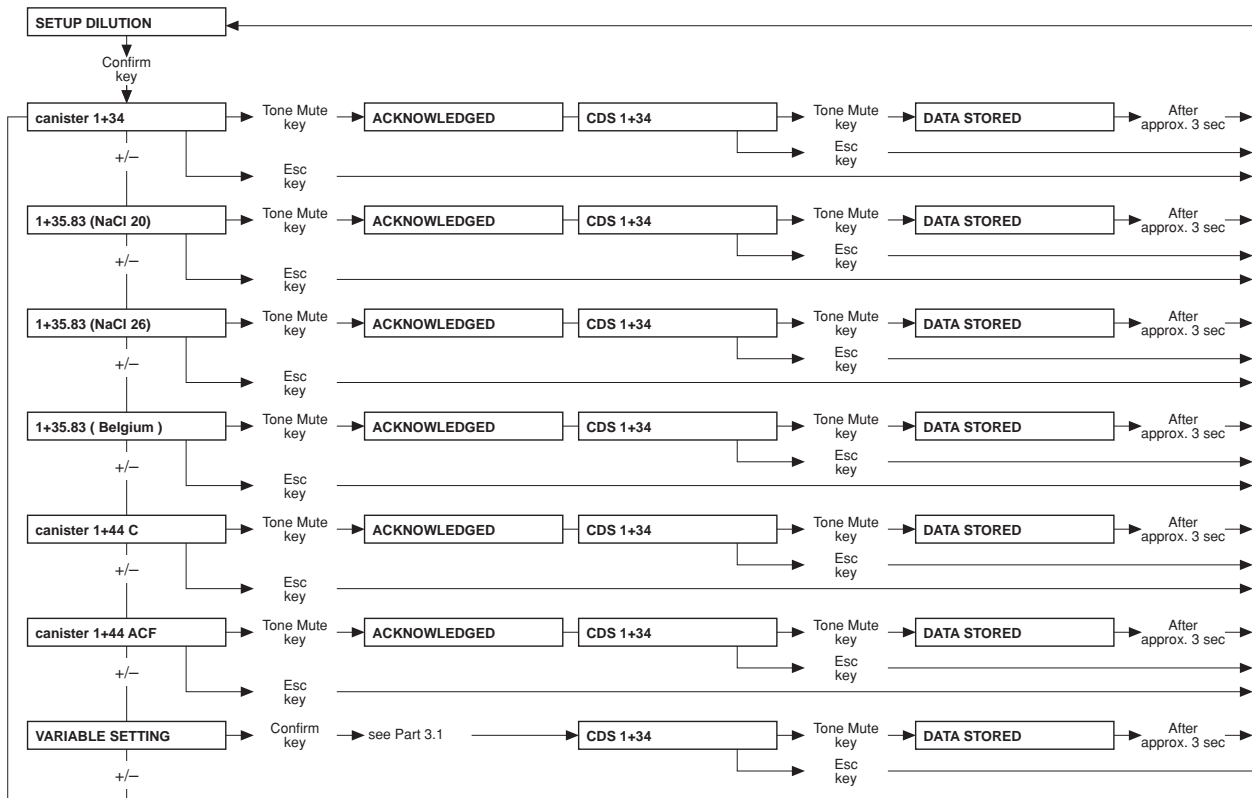

● **Part 3.1: Programmable mixing ratio (dilution)**



Caution

The operator or technician is informed about his duty of care to enter the component parameters and settings correctly or to check them and to set the CD alarm window to the expected conductivity value.

When using the programmable mixing ratio (dilution), make sure to use the right concentrate.

Using a bi_obag[®] in combination with the programmable mixing ratio (dilution) is not allowed.

Only enter authorized, programmable mixing ratios (dilutions).

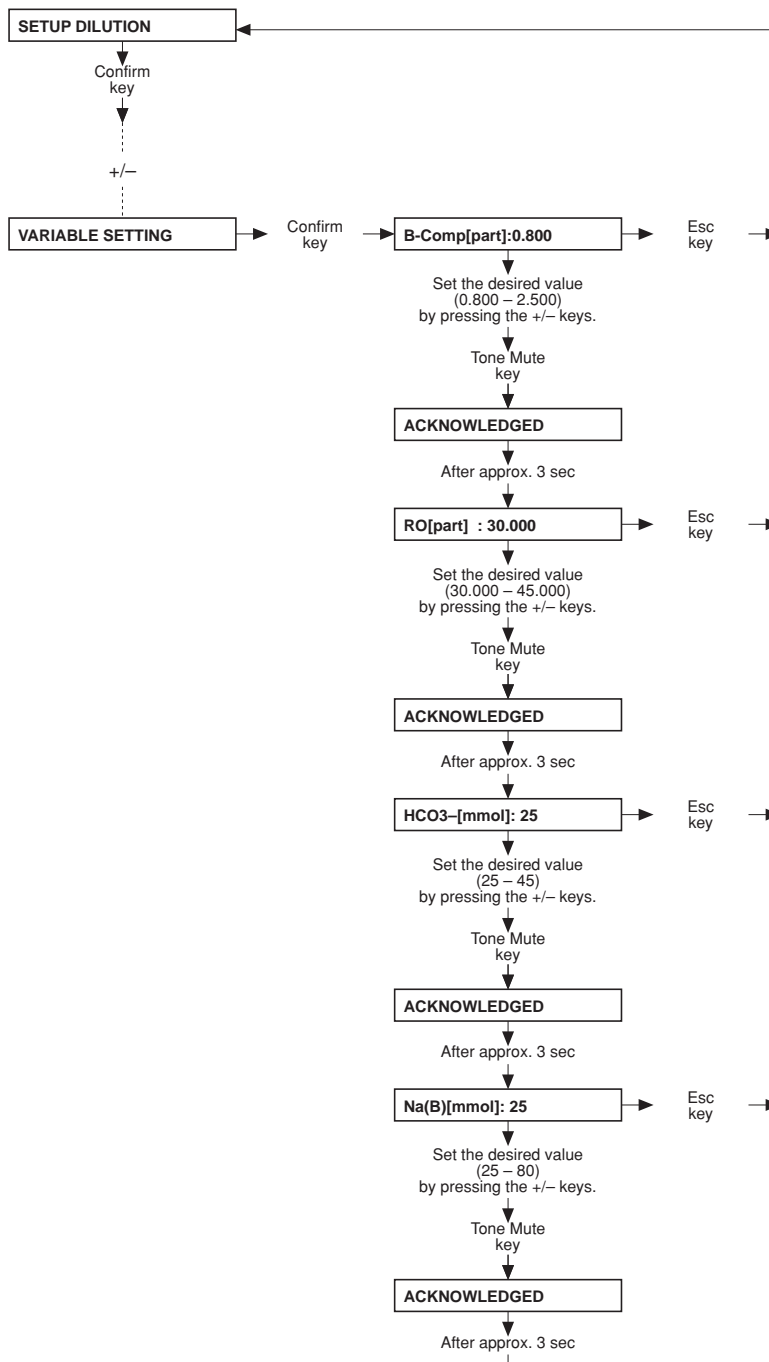

● **Part 4: Setting the HDF dilution – only for ON-LINE-HDF (option)**

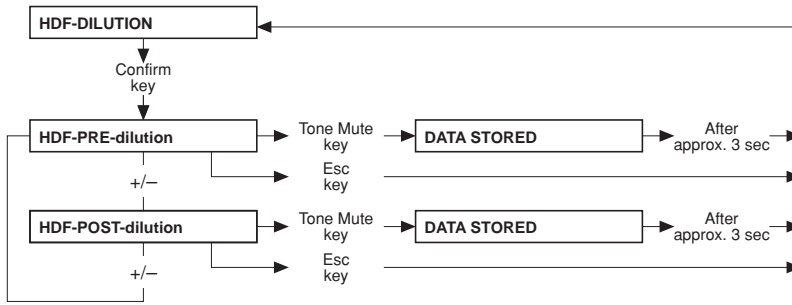

● **Part 5: Setting the conductivity limit**

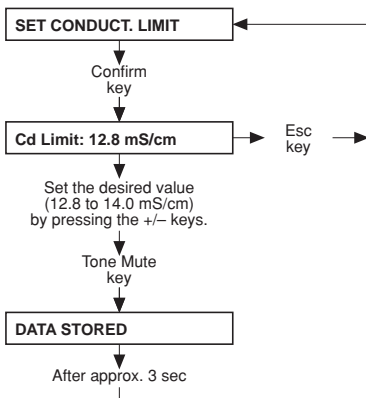

● **Part 6: Infosound cleaning program**

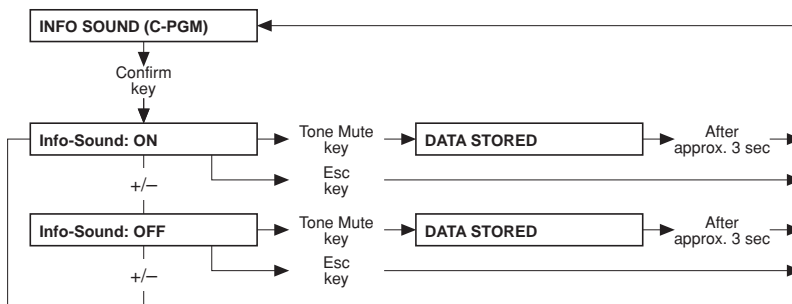

- **Part 7: Setting the dialysis parameters**

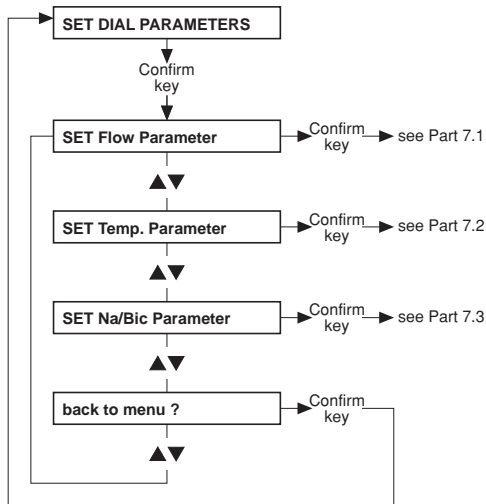

- **Part 7.1: Setting the dialysate flow**

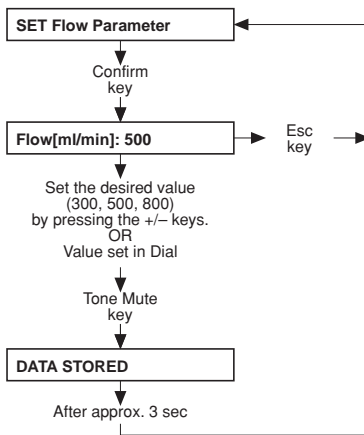

- **Part 7.2: Setting the dialysate temperature**

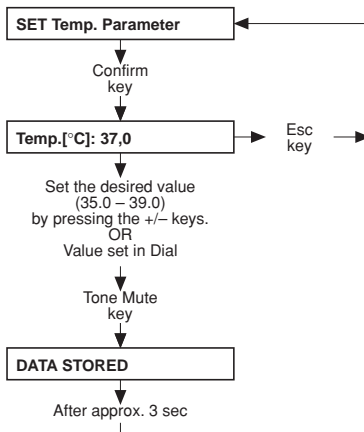

● **Part 7.3: Setting the Na/Bic**

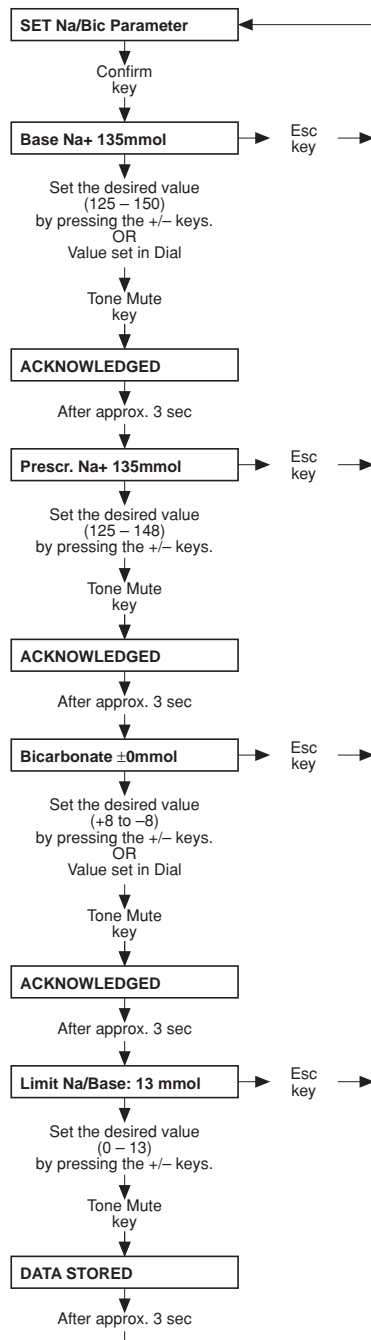

● **Part 8: Cumulated blood volume**

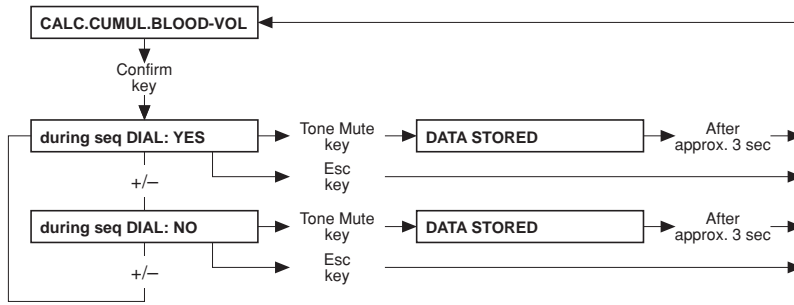

● **Part 9: Haemoglobin unit – only for BVM (option)**

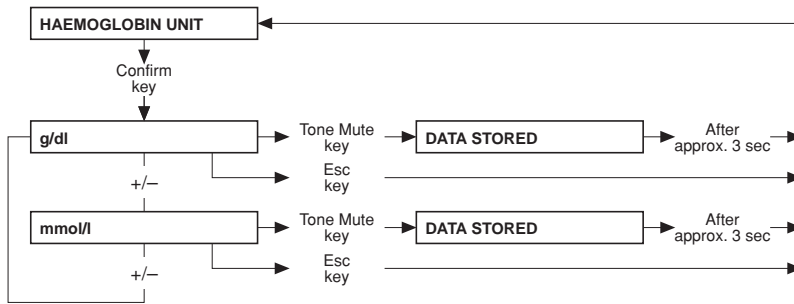

● Part 10: OCM settings – only for OCM (option)

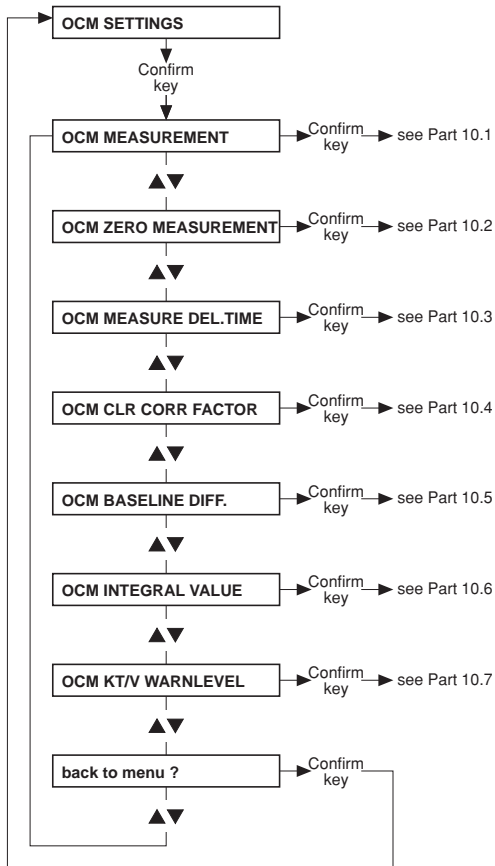

● **Part 10.1: Activating the OCM measurement**

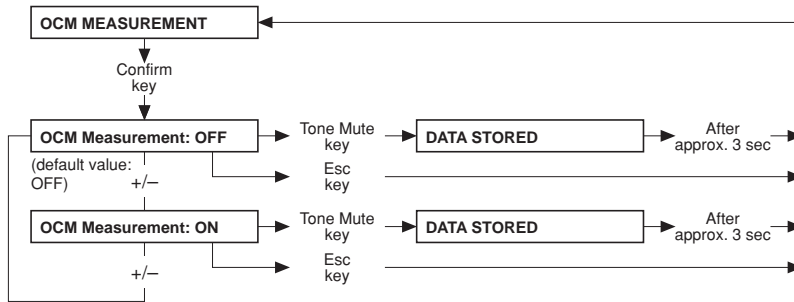

● **Part 10.2: Activating the OCM zero measurement**



Note

If the OCM zero measurement is set to “OFF”, the OCM option is deactivated. If the OCM option is reactivated (“ON”), an OCM pulse calibration must be performed.

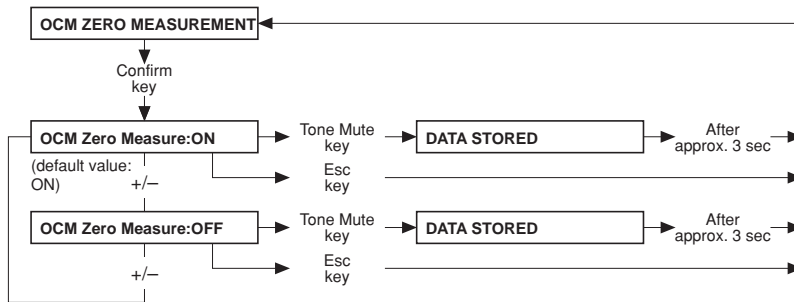

● **Part 10.3: Setting the OCM measurement delay time**

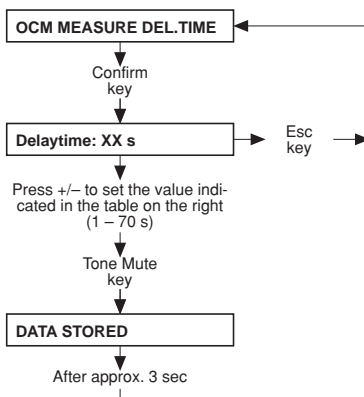

System	Time
4008 H with advanced hydraulics	15 Sec
4008 H with ONLINE ^{plus} TM	65 Sec
4008 S with advanced hydraulics	18 Sec
4008 S with ONLINE ^{plus} TM	67 Sec

- **Part 10.4: Setting the OCM correction factor**



Note
Do not change the default value.



Note
The 4008 H/S offers the theoretical possibility of defining a correction value for all clearance measurements. The intention is to be able to adapt the system to to the latest state of technology resulting from the on-going scientific discussion. According to the current standard of knowledge, this correction value has to be set to “1” (factory setting) for Fresenius polysulfone membranes. The indicated accuracy specifications are valid only for Fresenius polysulfone membrane combined with this correction value setting of “1”.

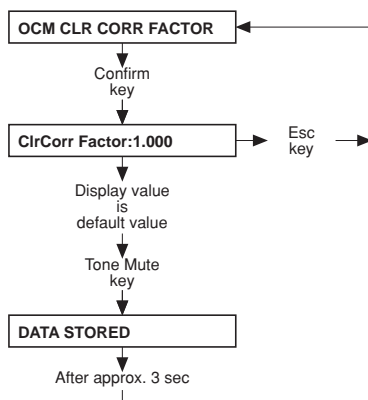

- **Part 10.5: Setting the OCM baseline difference**



Note
Do not change the default value.

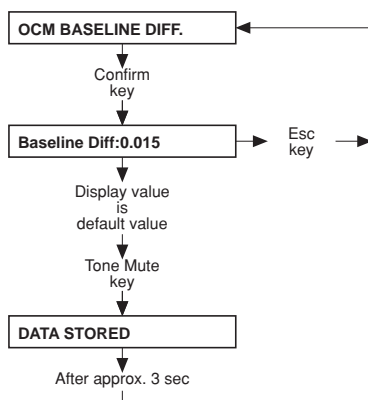

● **Part 10.6: Setting the OCM integral value**



Note
Do not change the default value.

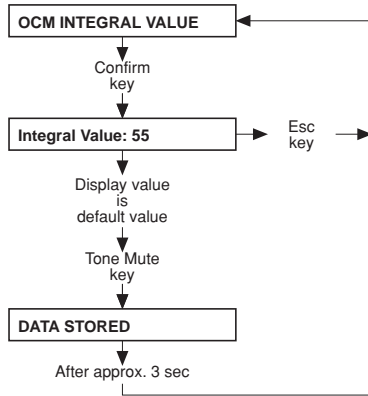

● **Part 10.7: Setting the OCM Kt/V warning level**

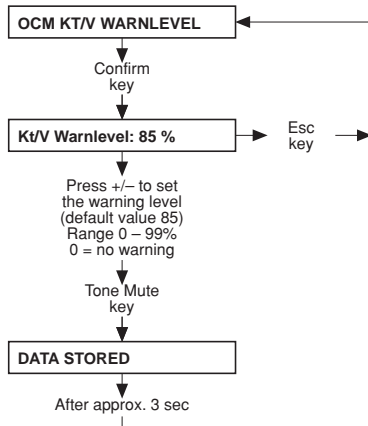

● **Part 11: Automatic Single-Needle start**

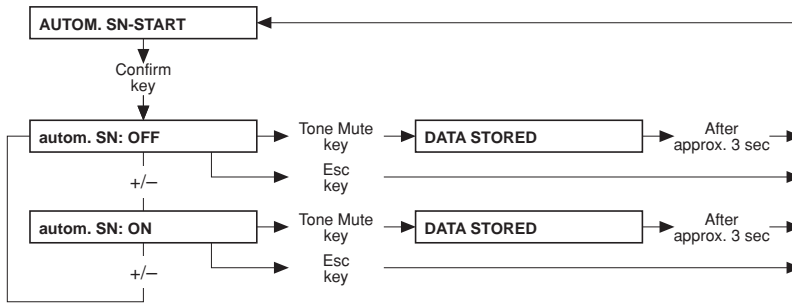

● **Part 12: Activation of Monit_NTC 109**

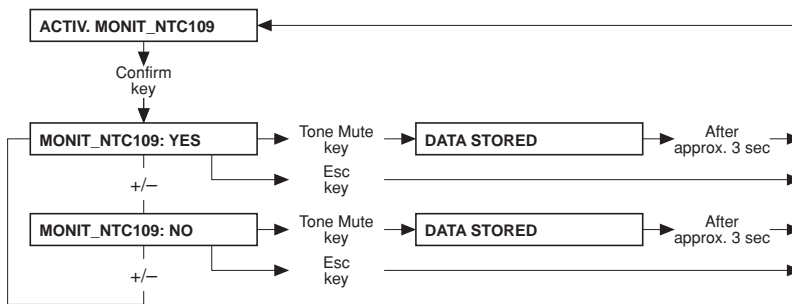

● **Part 13: Activation of standard UF data**

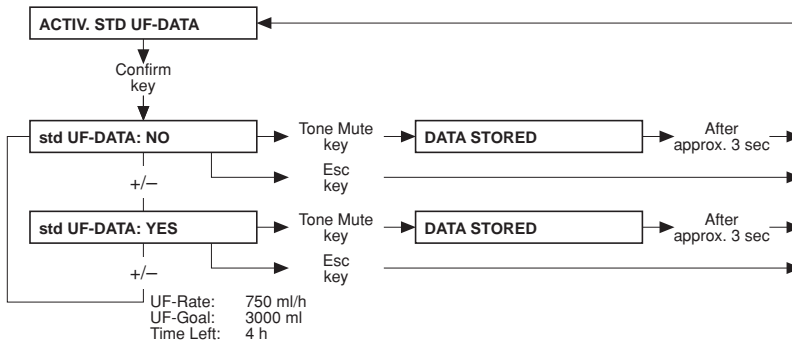

- **Part 14: Setting the priming time**

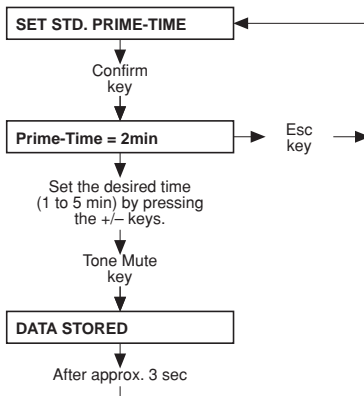

- **Part 15: Warning sound I/O key**

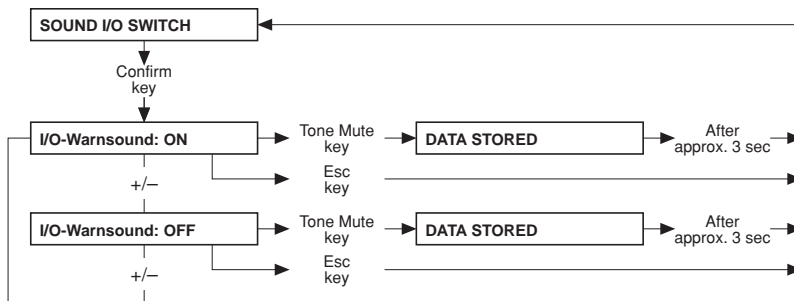

- **Part 16: Setting the key-click**

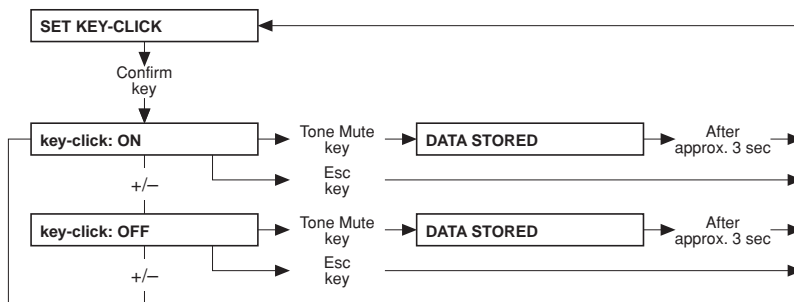

● **Part 17: Setting the BPR/UFR warning**

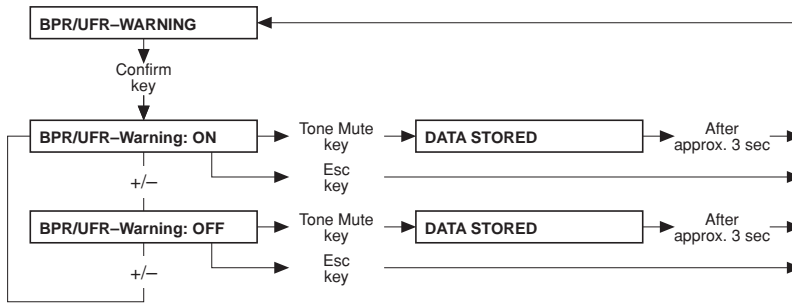

● **Part 18: Setting the rinse volume**

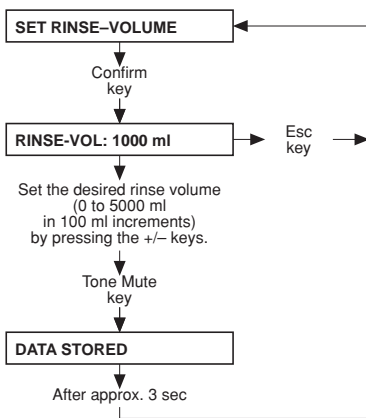

● **Part 19: T1-Test Autostart**

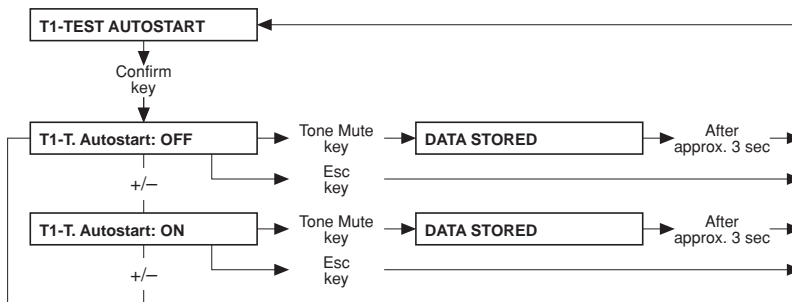

● Part 20: ONLINEplus™ settings – only for ONLINEplus™ (option)

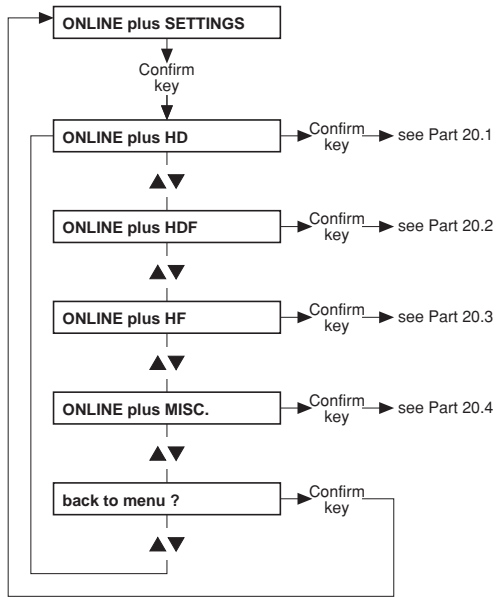

● **Part 20.1: ONLINE^{plus}™ HD**

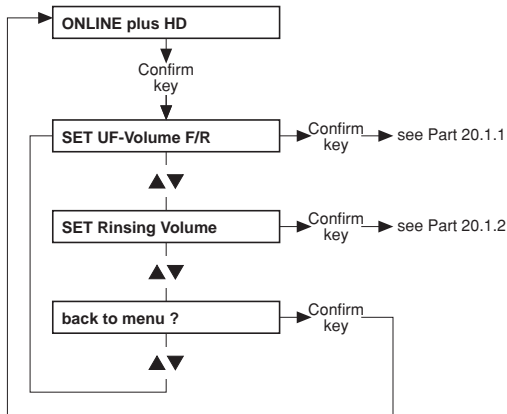

● **Part 20.1.1: Setting the UF volume (filling/rinsing)**

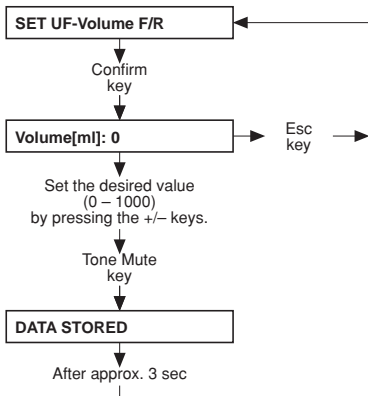

● **Part 20.1.2: Setting the rinse volume**

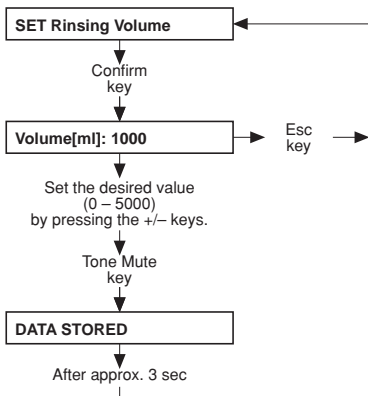

● **Part 20.2: ONLINE^{plus}™ HDF**

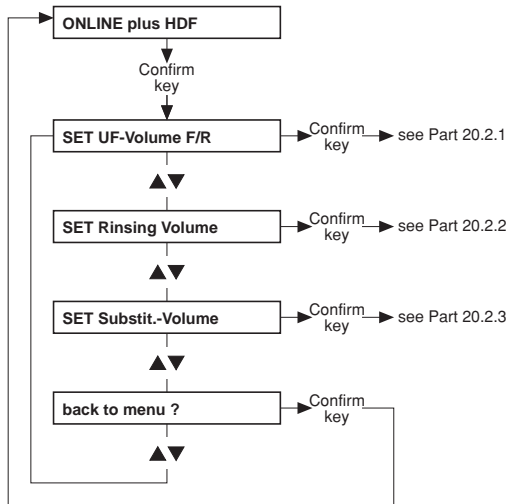

● **Part 20.2.1: Setting the UF volume (filling/rinsing)**

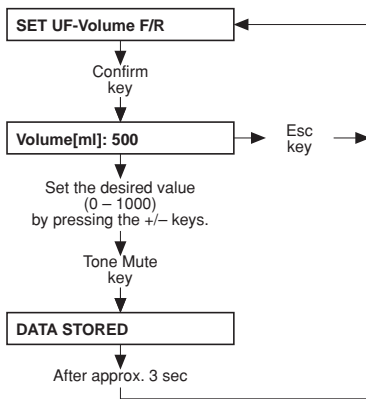

● **Part 20.2.2: Setting the rinse volume**

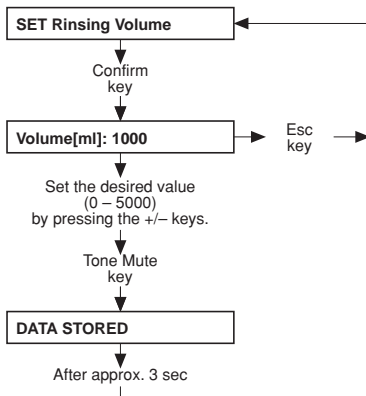

● **Part 20.2.3: Setting the substitute volume**

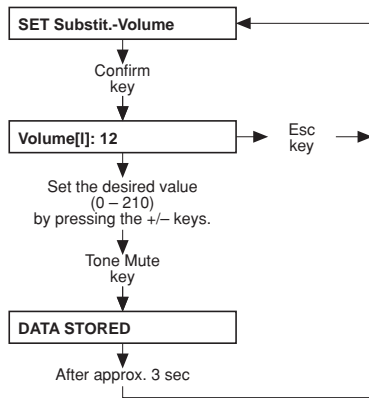

● **Part 20.3: ONLINE^{plus}™ HF**

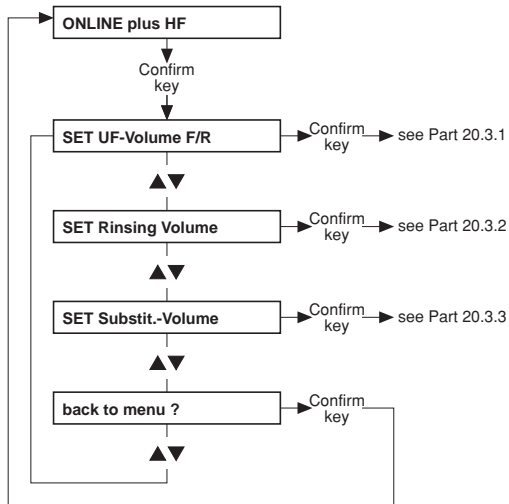

● **Part 20.3.1: Setting the UF volume (filling/rinsing)**

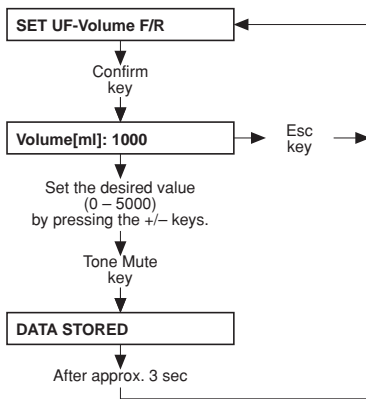

● **Part 20.3.2: Setting the rinse volume**

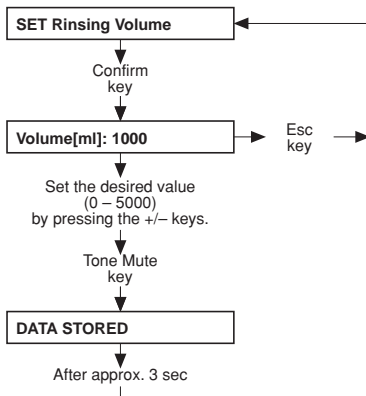

● **Part 20.3.3: Setting the substitute volume**

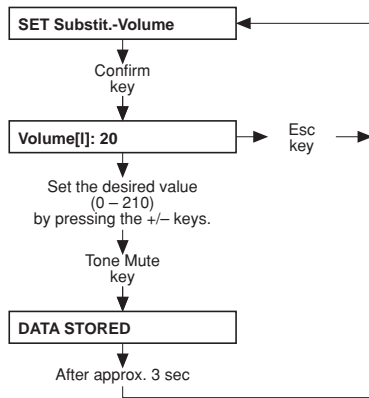

● **Part 20.4: ONLINE^{plus}™ miscellaneous**

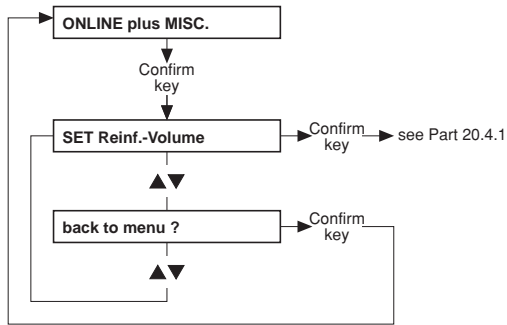

● **Part 20.4.1: Setting the reinfusion volume**

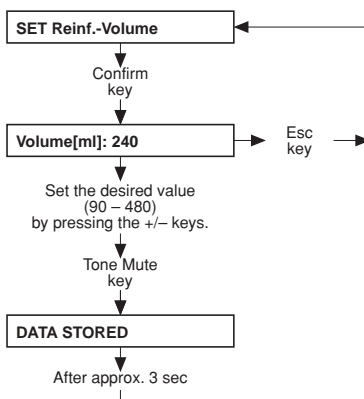

- **Part 21: Setting the parameters for central delivery system**



Note
Central delivery is not available for the 3mix option.

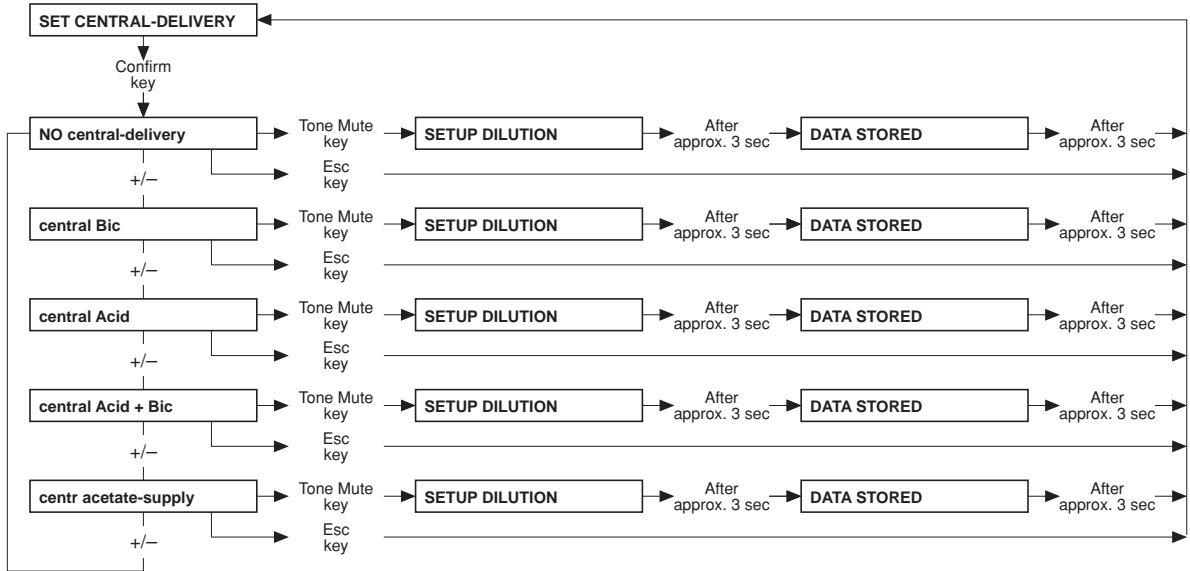

- **Part 22: AutoOFF after AutoON**

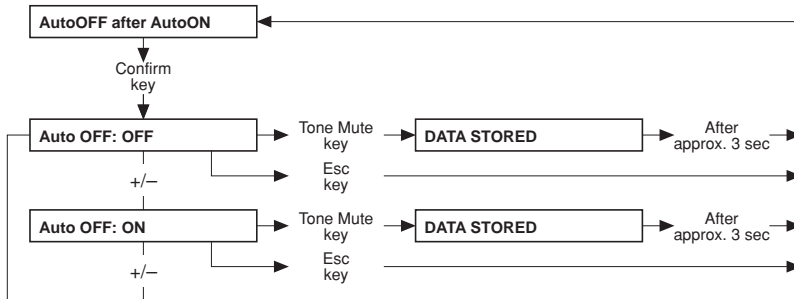

- **Part 23: CAMUS-baudrate**

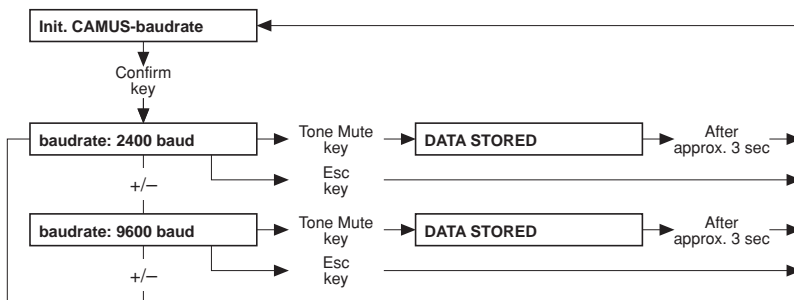

- **Part 24: Storing the default values**

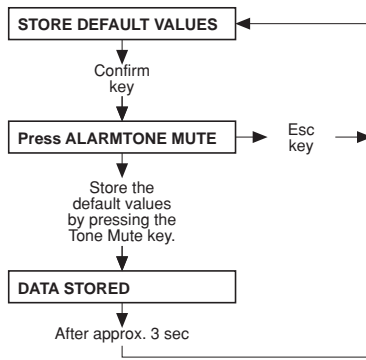

7 Miscellaneous

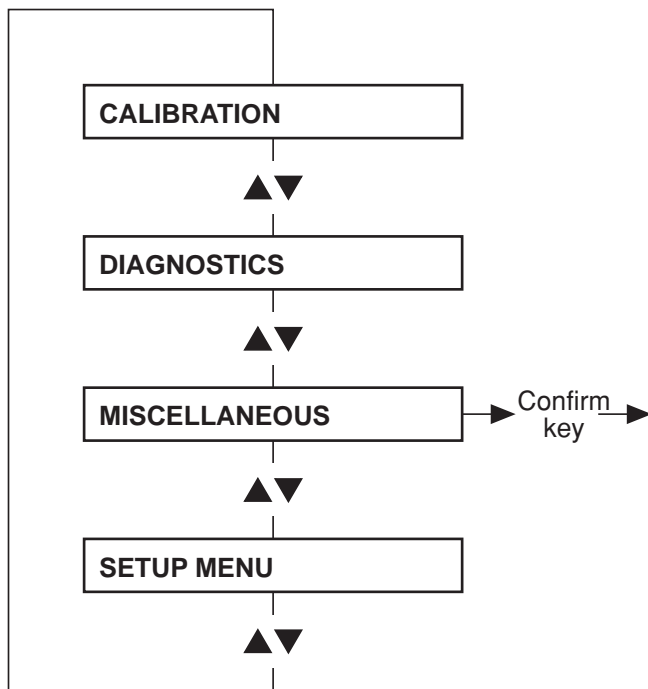

- Main menu

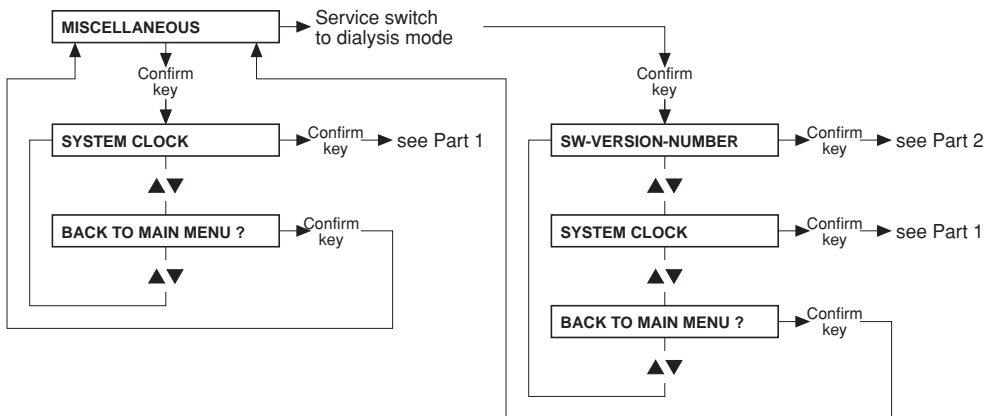

● Part 1

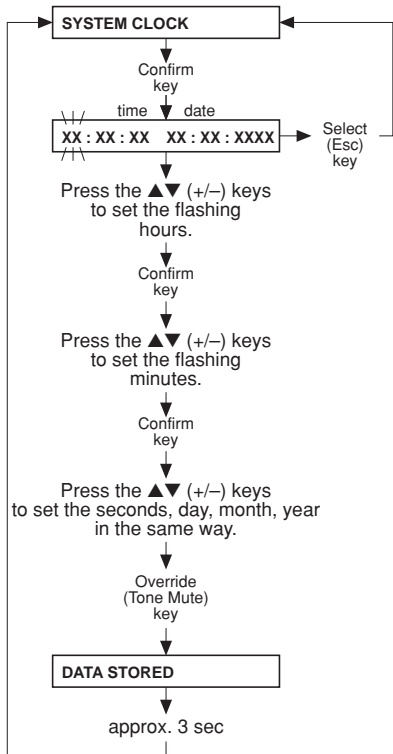

● Part 2

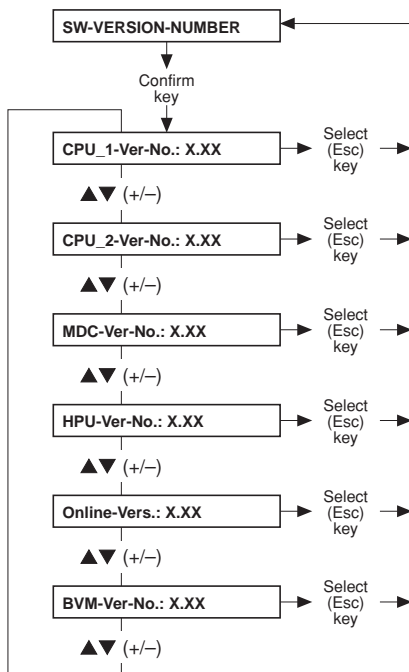

Table of contents

8 Circuit diagrams and circuit descriptions

Section	Page
8.1	Block diagram 4008 8-3
8.2	Block diagram of voltage supply 8-4
8.3	Block diagram of screen 4008 H/S 8-5
8.4	Connection layout diagram 8-6
8.4.1	Connection diagram CAN communication 8-7
8.4.2	Hydraulics processor block diagram 8-8
8.5	P.C.B. LP 450-2 Level detector control (LD) 8-9
8.6	P.C.B. LP 493 Blood leak detector 8-11
8.7	P.C.B. LP 624 Control board (BP) 8-12
8.8	P.C.B. LP 630 Motherboard 8-13
8.9	P.C.B. LP 631 CPU 1 8-14
8.10	P.C.B. LP 632 CPU 2 8-16
8.11	P.C.B. LP 633 Input board 8-18
8.12	P.C.B. LP 634 Output board 8-20
8.13	P.C.B. LP 635 Display board 8-22
8.14	P.C.B. LP 636 External connectors 8-24
8.15	P.C.B. LP 950 Control board (HEP) 8-25
8.16	P.C.B. LP 644-4 Display board (HEP) 8-26
8.17	P.C.B. LP 645 Position sensor membrane pump 8-27
8.18	P.C.B. LP 649-2 Display board (4008 B/S) 8-28
8.19	P.C.B. LP 742 Interference filter 8-30
8.20	P.C.B. LP 748 Display board (BP) 8-31
8.21	P.C.B. LP 763 Multi interface board (COMMCO III) 8-32
8.22	P.C.B. LP 922 Display board (4008 S) 8-33
8.23	P.C.B. LP 923 Traffic light (4008 H/S) 8-34
8.24	P.C.B. LP 924 Display board (4008 H) 8-35
8.25	P.C.B. LP 941 Hydraulics processor 8-36

Section		Page
8.26	Heater board (power supply unit 4008)	8-37
8.27	Power board (power supply unit 4008)	8-38

8.1 Block diagram 4008

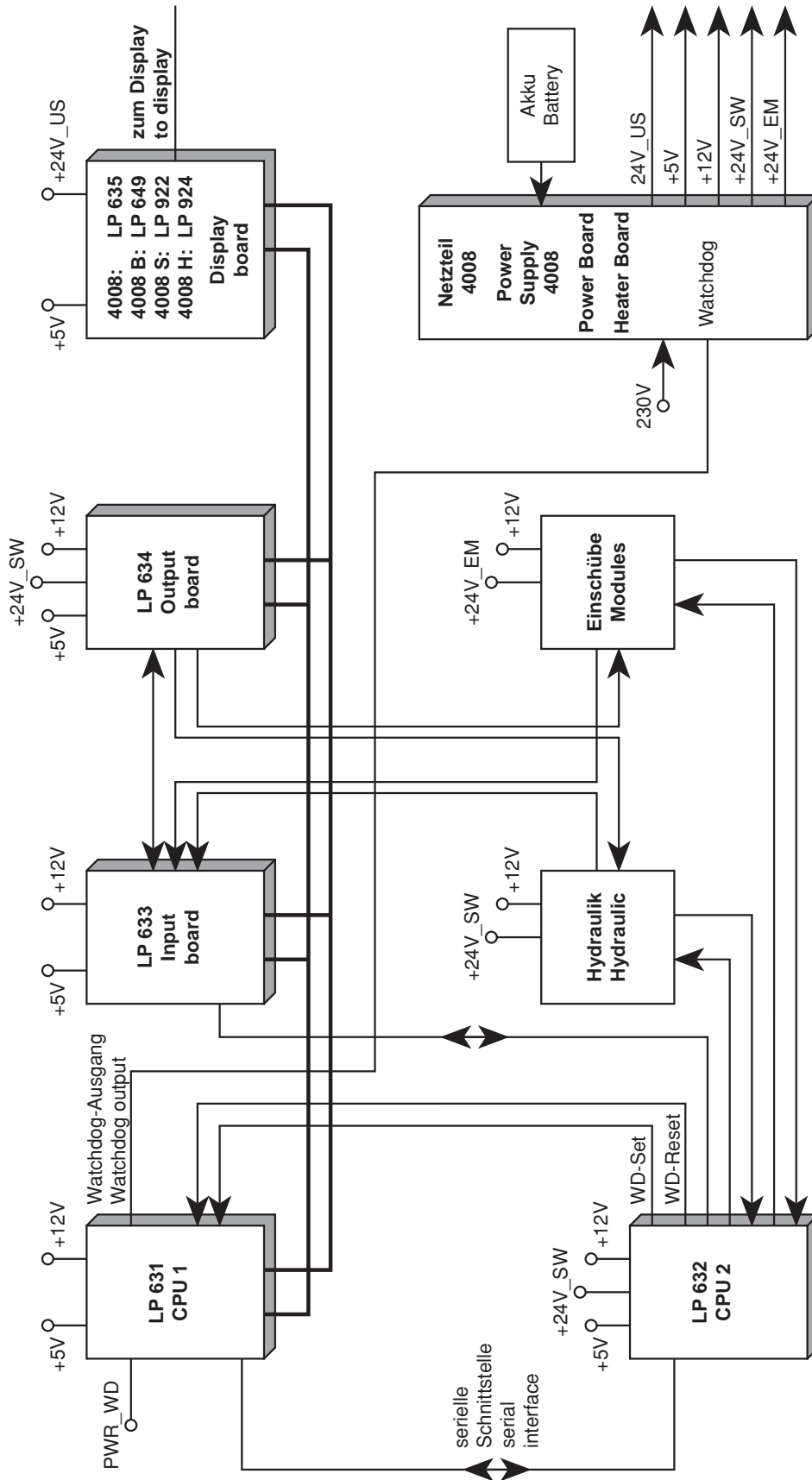

8.2 Block diagram of voltage supply

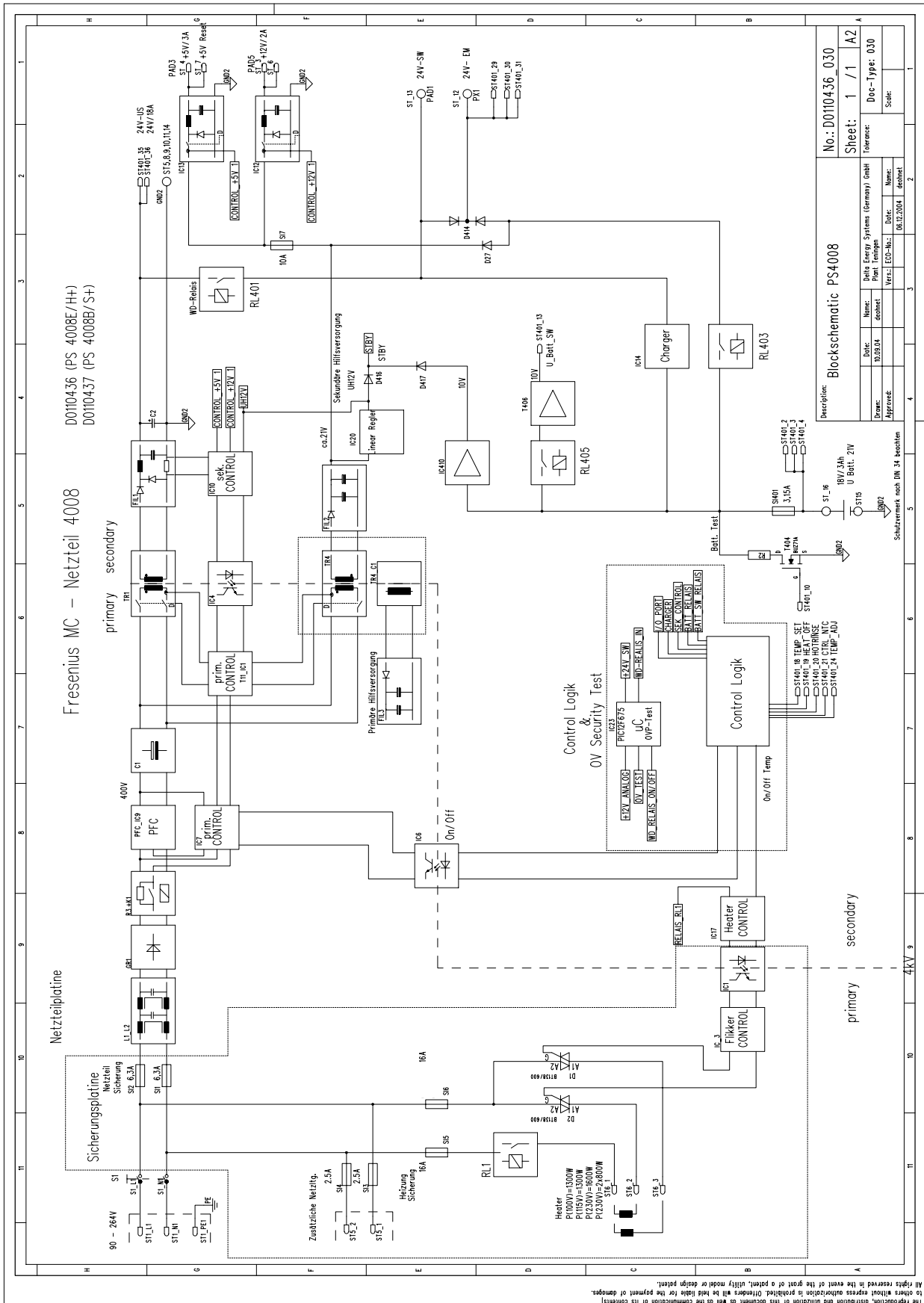

8.3 Block diagram of screen 4008 H/S

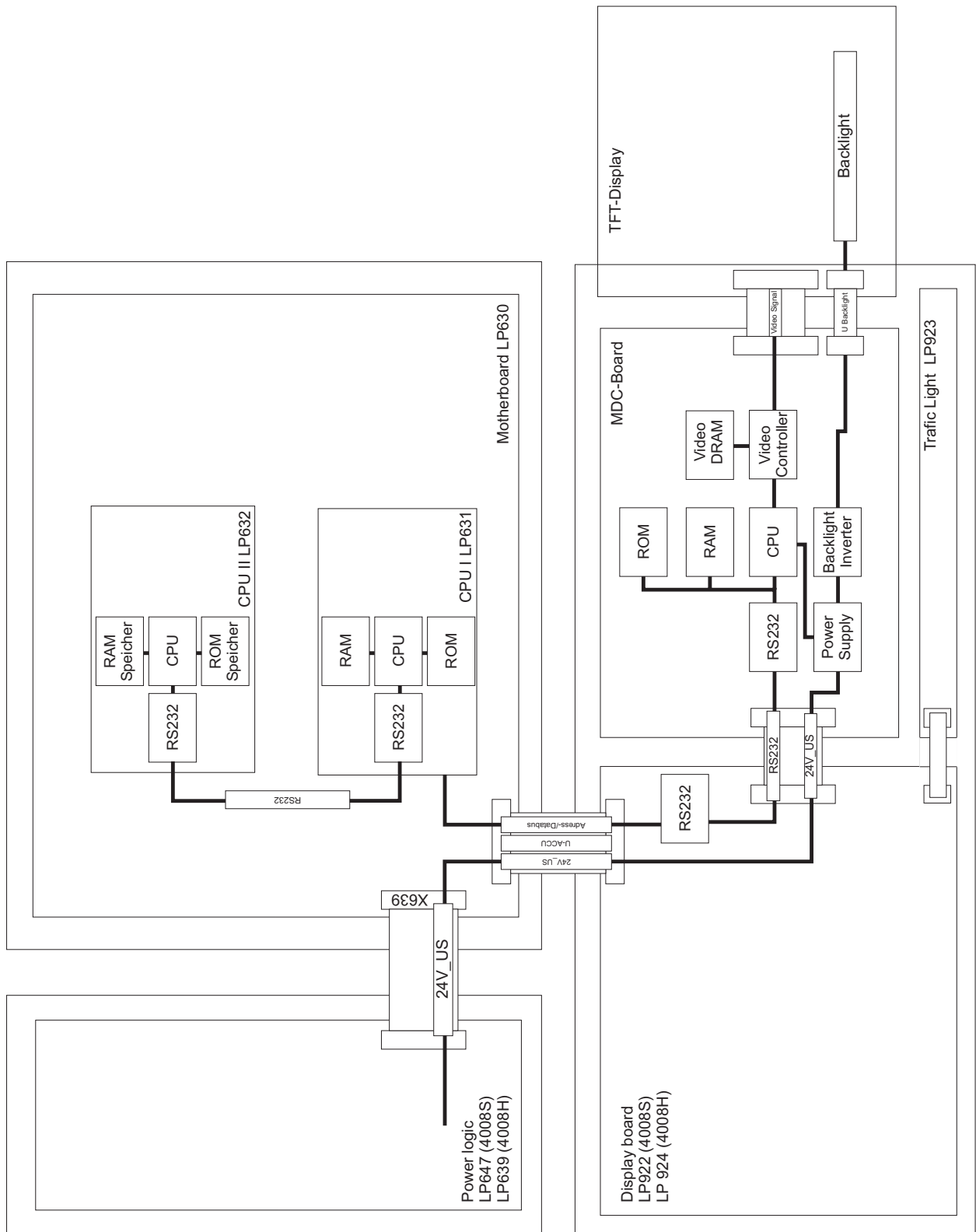

8.4 Connection layout diagram

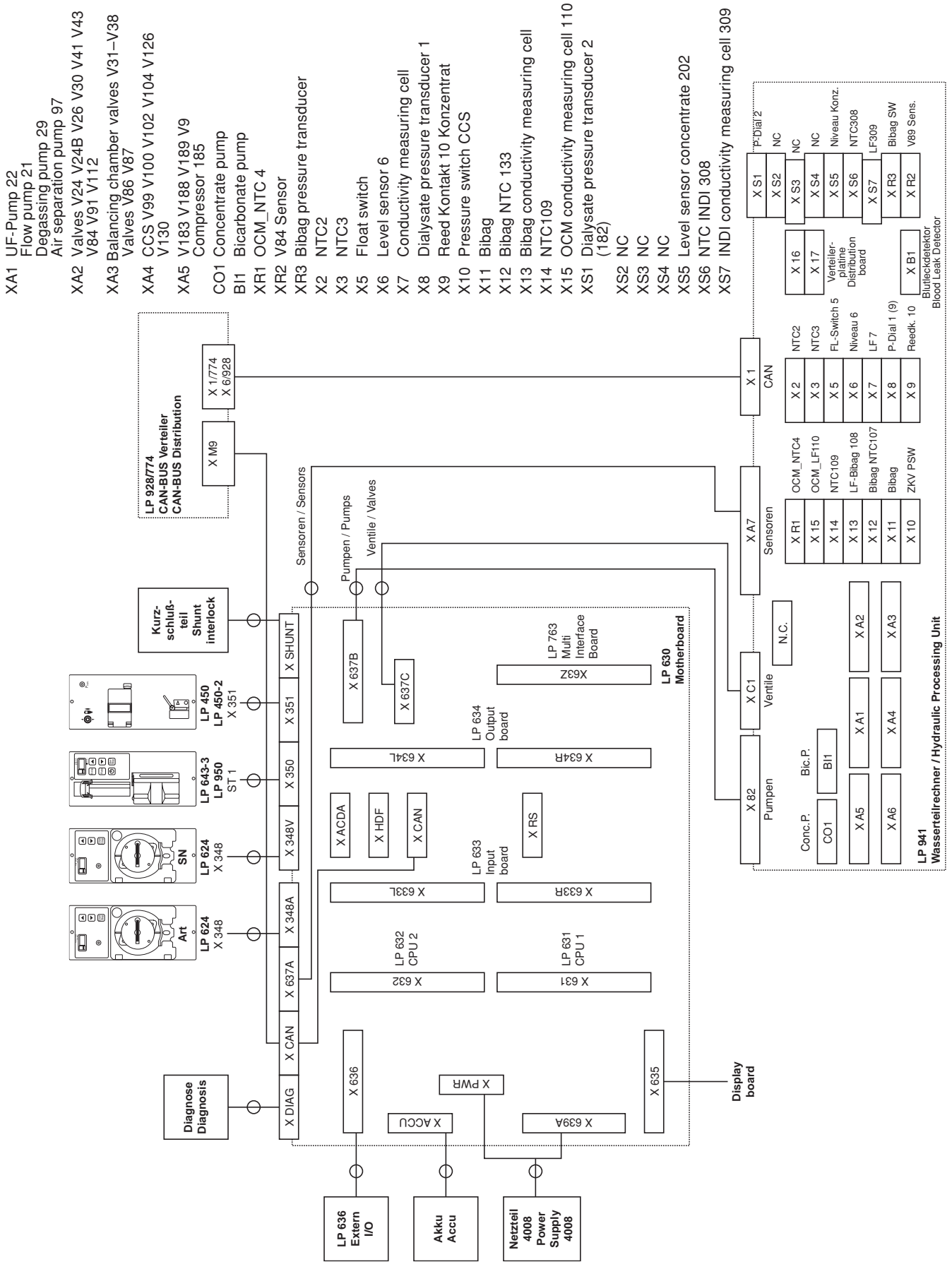

8.4.1 Connection diagram CAN communication

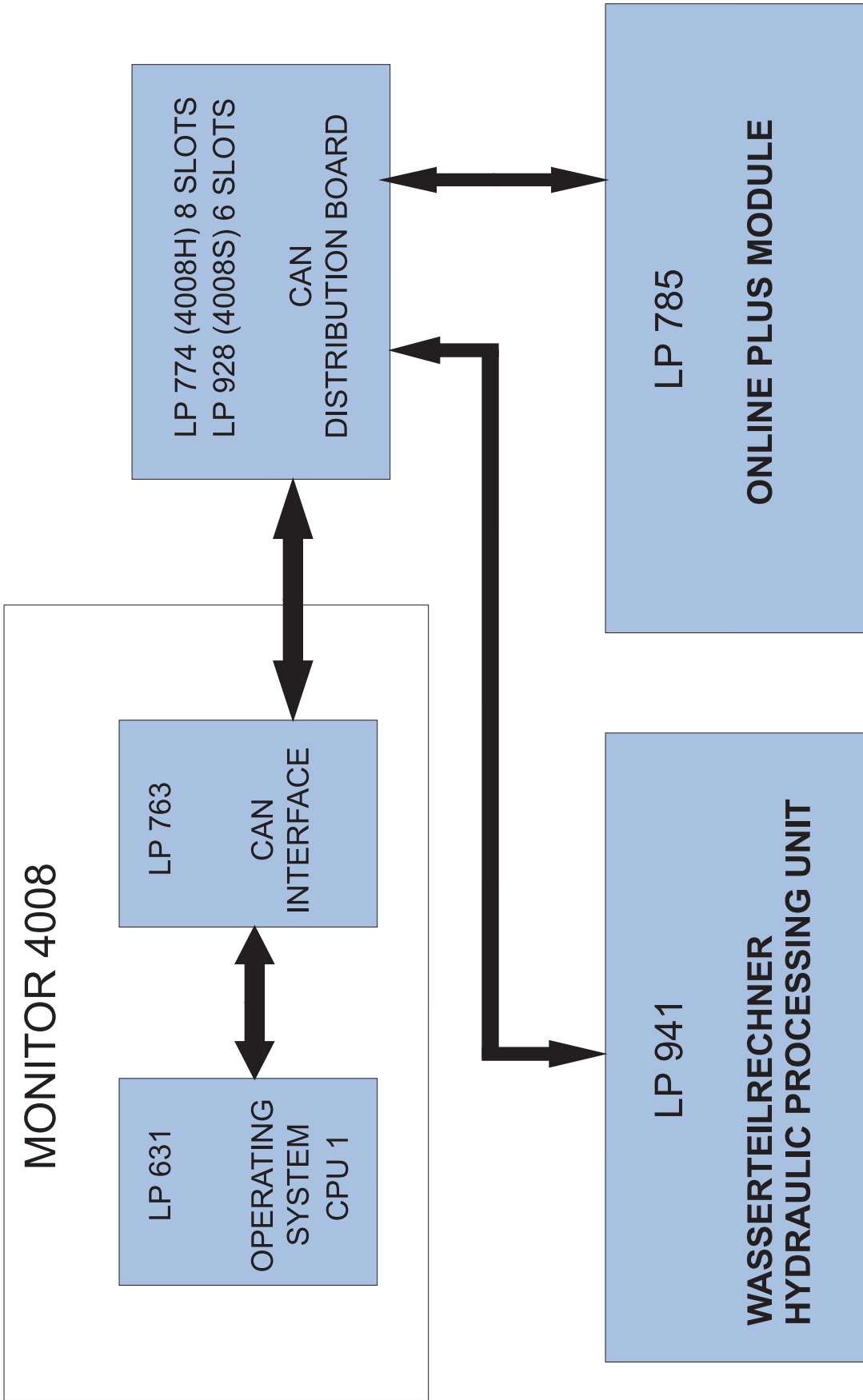

8.4.2 Hydraulics processor block diagram

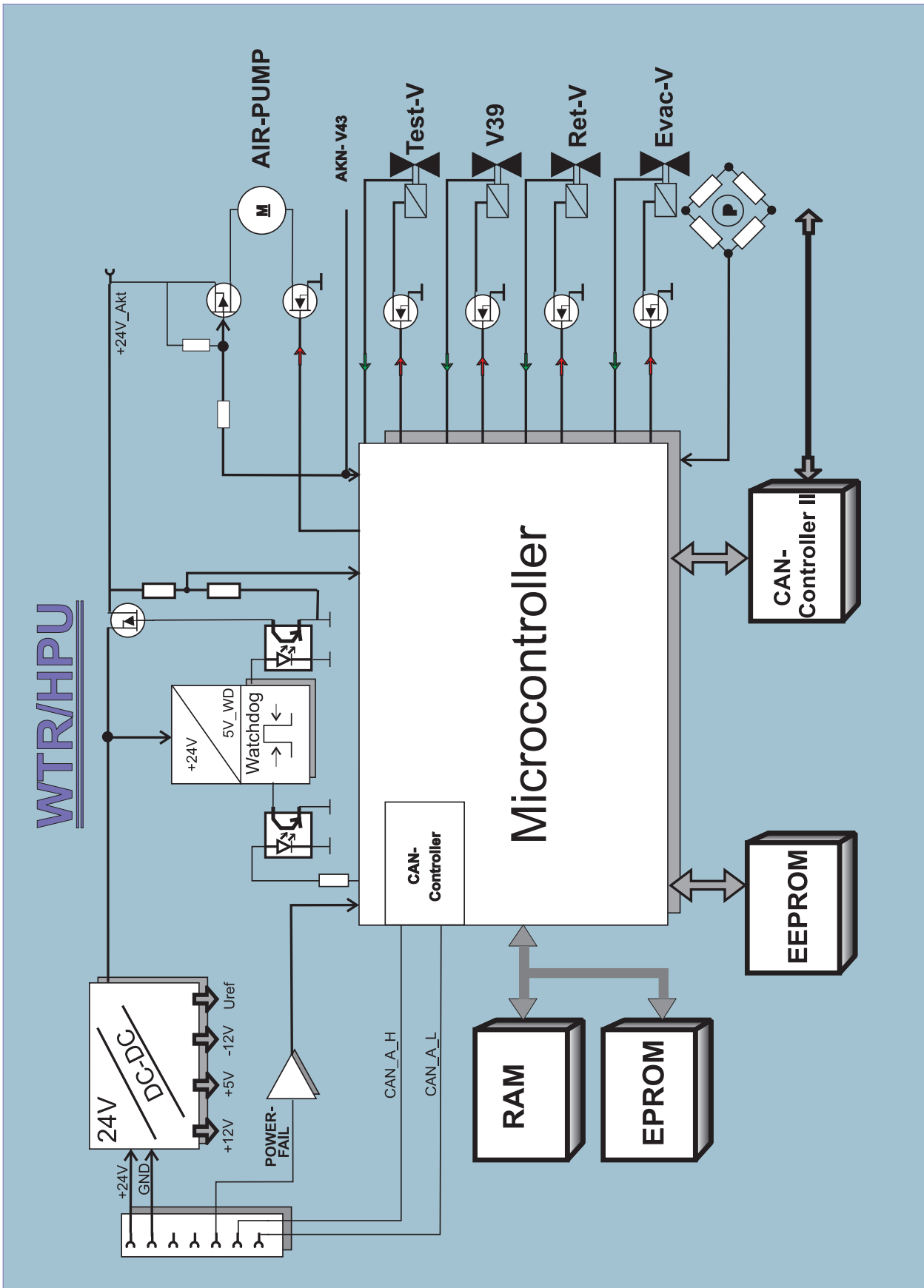

8.5 P.C.B. LP 450-2 Level detector control (LD)

Fig.: Signal plan P.C.B. LP 450-2

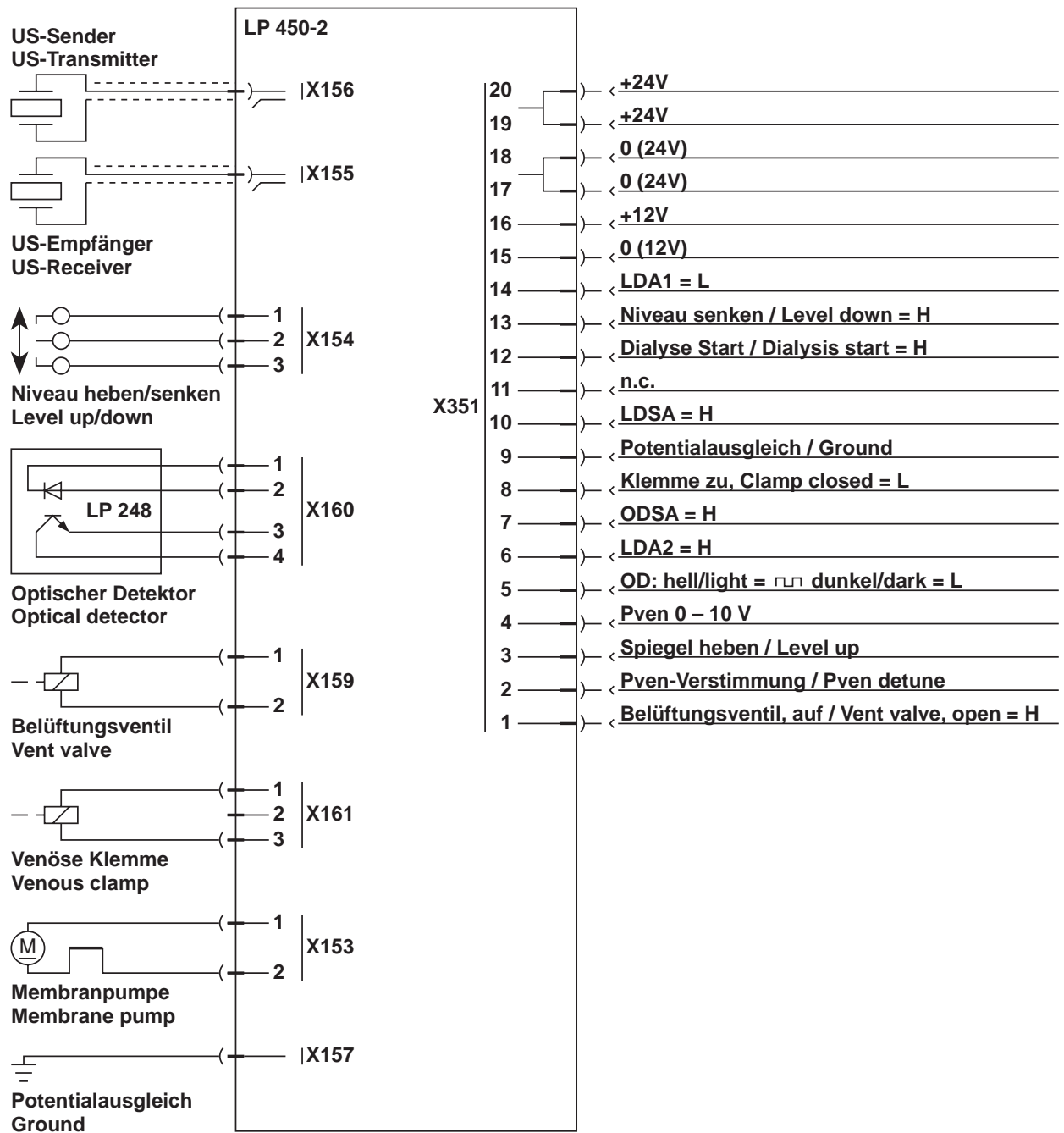

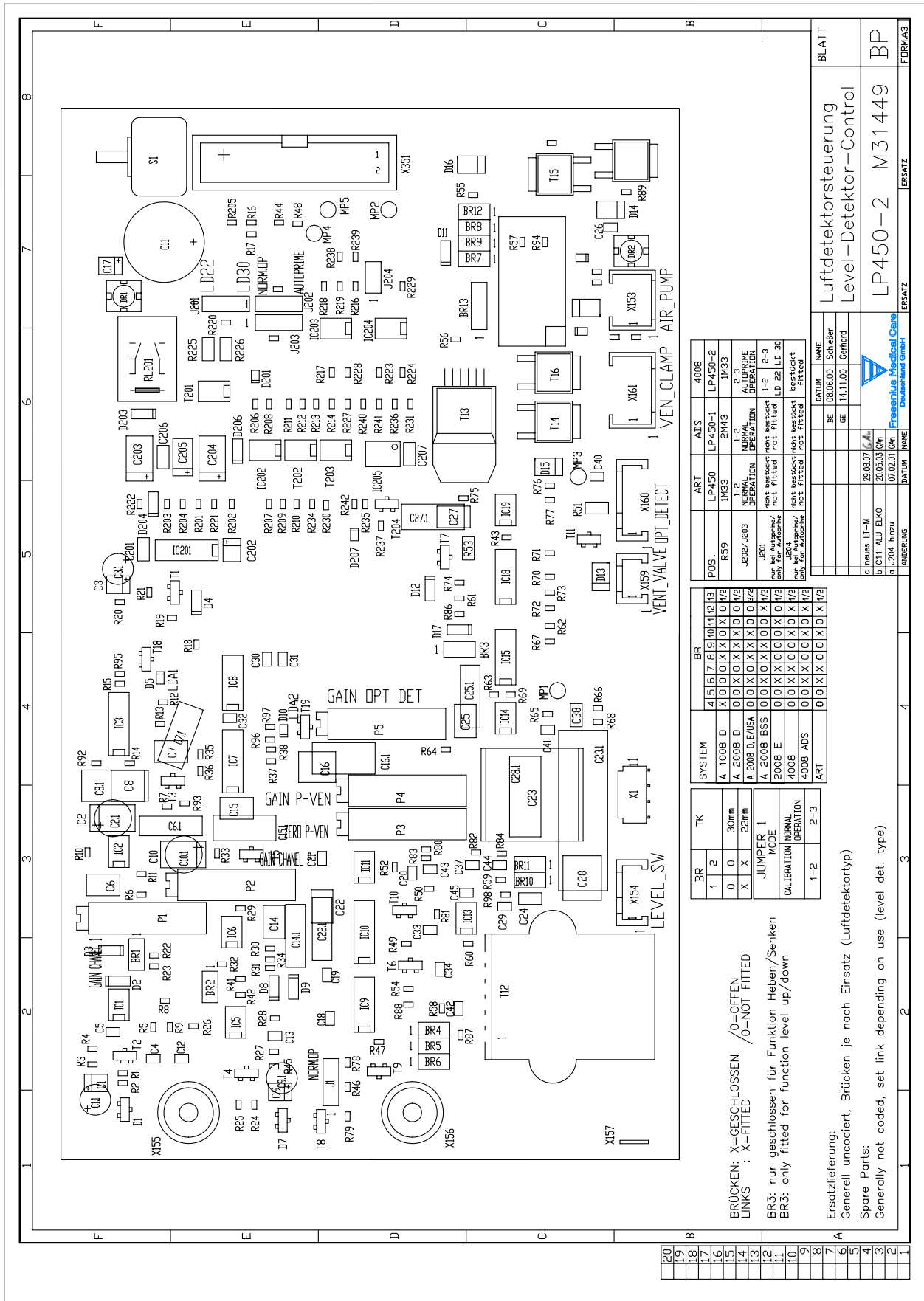

POS.	ART	NAME	DATUM	NAME
R59	LP450	LP450-1	BE 08.06.00	Schleier
J002/J003	M33	2M43	GE 14.11.00	Gerhard
J001	NORMAL OPERATION	NORMAL OPERATION		
J004	not bestückt	not fitted		
J005	not bestückt	not fitted		
J006	not bestückt	not fitted		
J007	not bestückt	not fitted		
J008	not bestückt	not fitted		
J009	not bestückt	not fitted		
J010	not bestückt	not fitted		

BR	TK	SYSTEM	BR
1	2	A 100B D	4
0	0	A 200B D	5
X	X	A 200B D/E/A	6
0	0	A 200B BSS	7
0	0	200B E	8
0	0	400B	9
0	0	400B AUS	10
0	0	ART	11

BR	TK	MODE	OPERATION
1	2	JUMPER 1	
0	0	30mm	
X	X	22mm	
0	0	CALIBRATION	
0	0	NORMAL	
0	0	OPERATION	
1-2	2-3		

BRÜCKEN: X=GESCHLOSSEN /0=OFFEN
 LINKS : X=FITTED /0=NOT FITTED

BR3: nur geschlossen für: Funktion Heben/Senken
 BR3: only fitted for function level up/down

Ersatzlieferung:
 Generell uncodiert, Brücken je nach Einsatz (Luftdetektortyp)
 Spare Parts:
 Generally not coded, set link depending on use (level det. type)

INFORMATION	DATUM	NAME	ERSATZ
c neues LI-M	29.08.07	6	
b C11 ALU ECKO	20.05.03	5	
g U204 hinzu	07.02.01	5	

INFORMATION	DATUM	NAME	ERSATZ
Luftdetektorsteuerung			BLATT
Level-Detektor-Control			
LP450-2		M31449	

8.6 P.C.B. LP 493 Blood leak detector

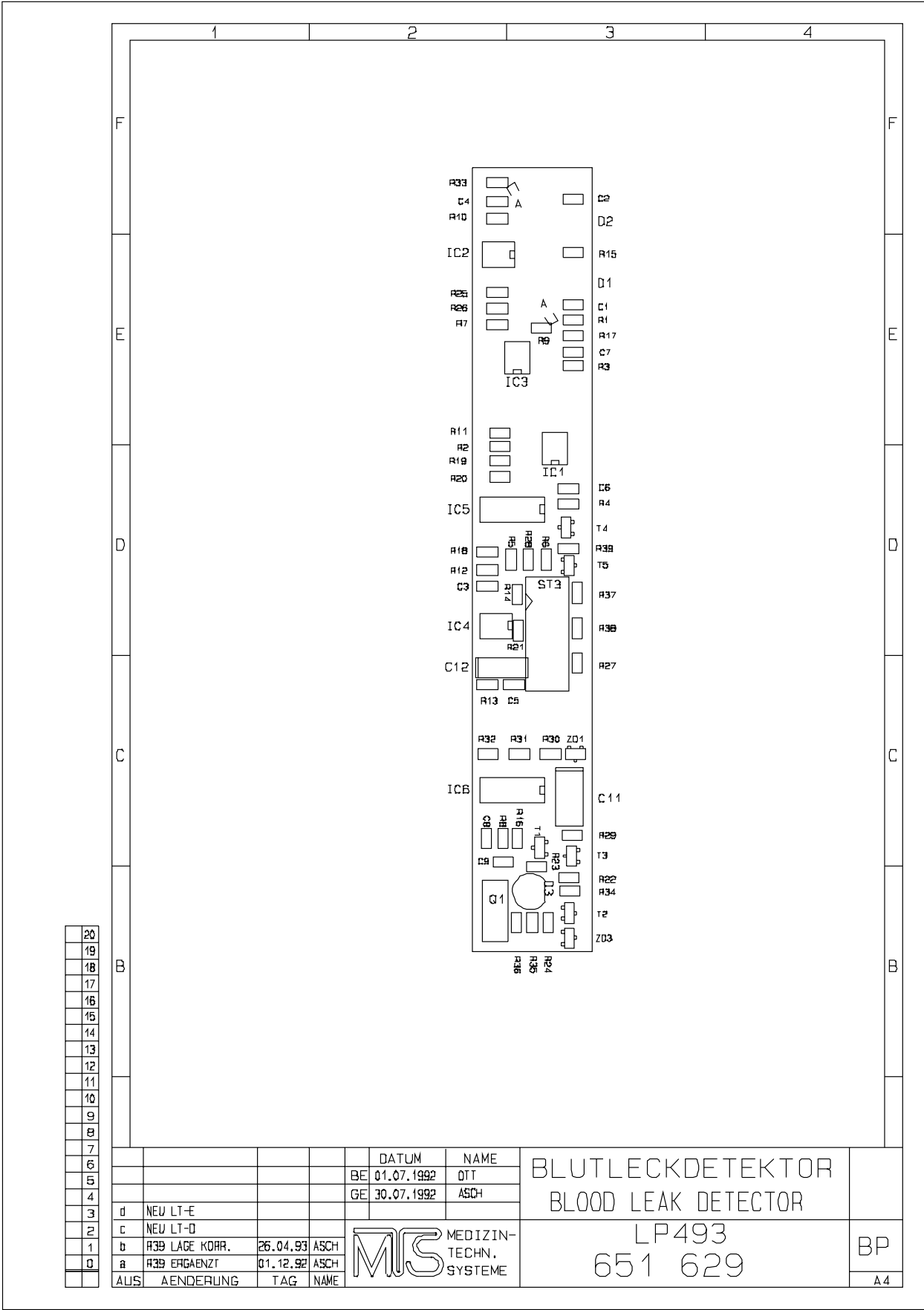

8.7 P.C.B. LP 624 Control board (BP)

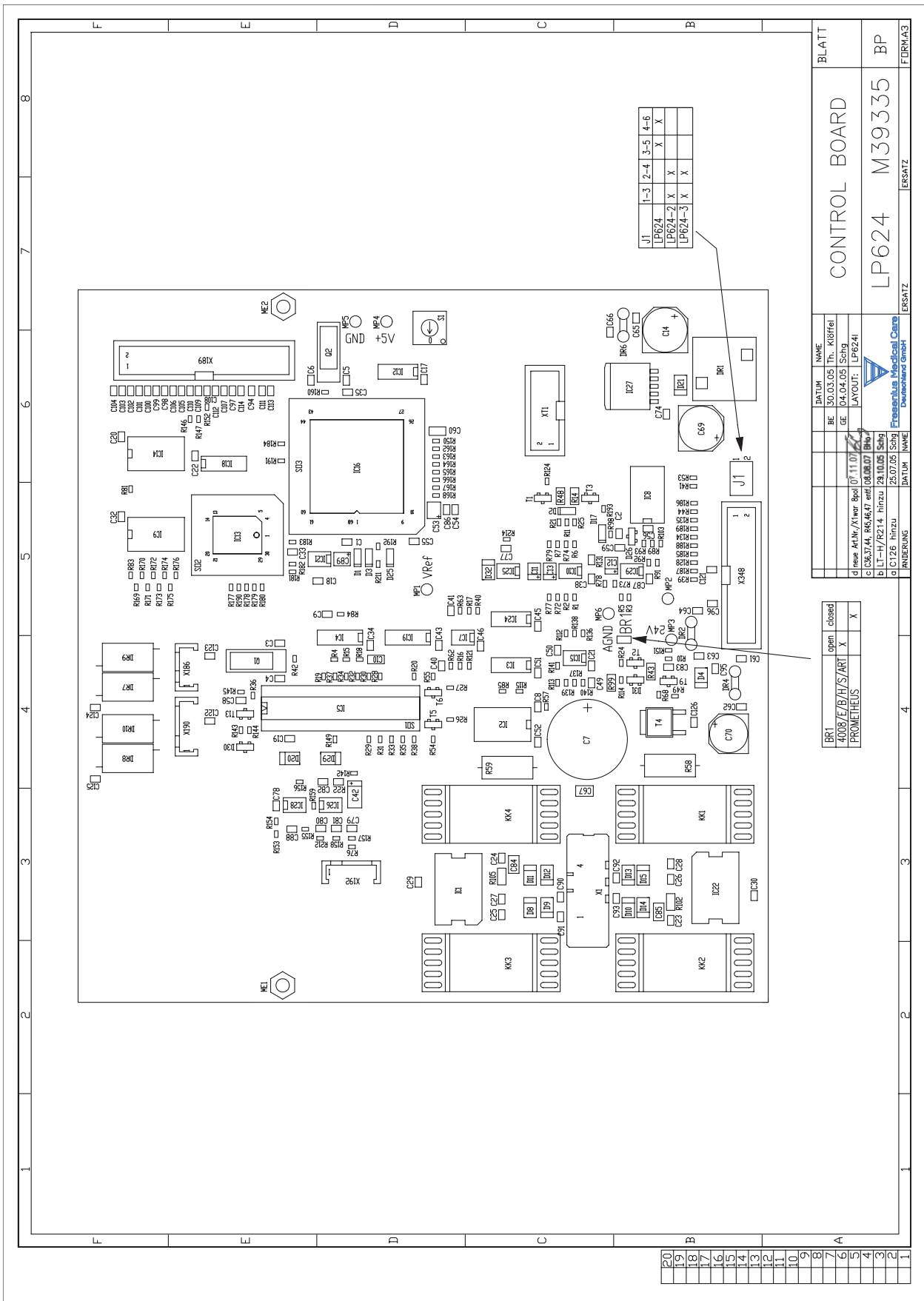

RE	10.03.05	Th. Küsterfel
GE	04.04.05	ES:cg
LAYOUT:	LP624	
d) neue Art.Nr./Y1wert	8941	01.11.01
e) C66,374, R63,67 entf.	08.08.07	BP6
b) L1-H/R214 hinzü	29.10.08	Schg
a) C126 hinzü	25.07.05	Schg
ÄNDERUNG	DATUM	NAMME
ERSATZ	ERSATZ	FORMIA3

CONTROL BOARD
 LP624 M39335

8.8 P.C.B. LP 630 Motherboard

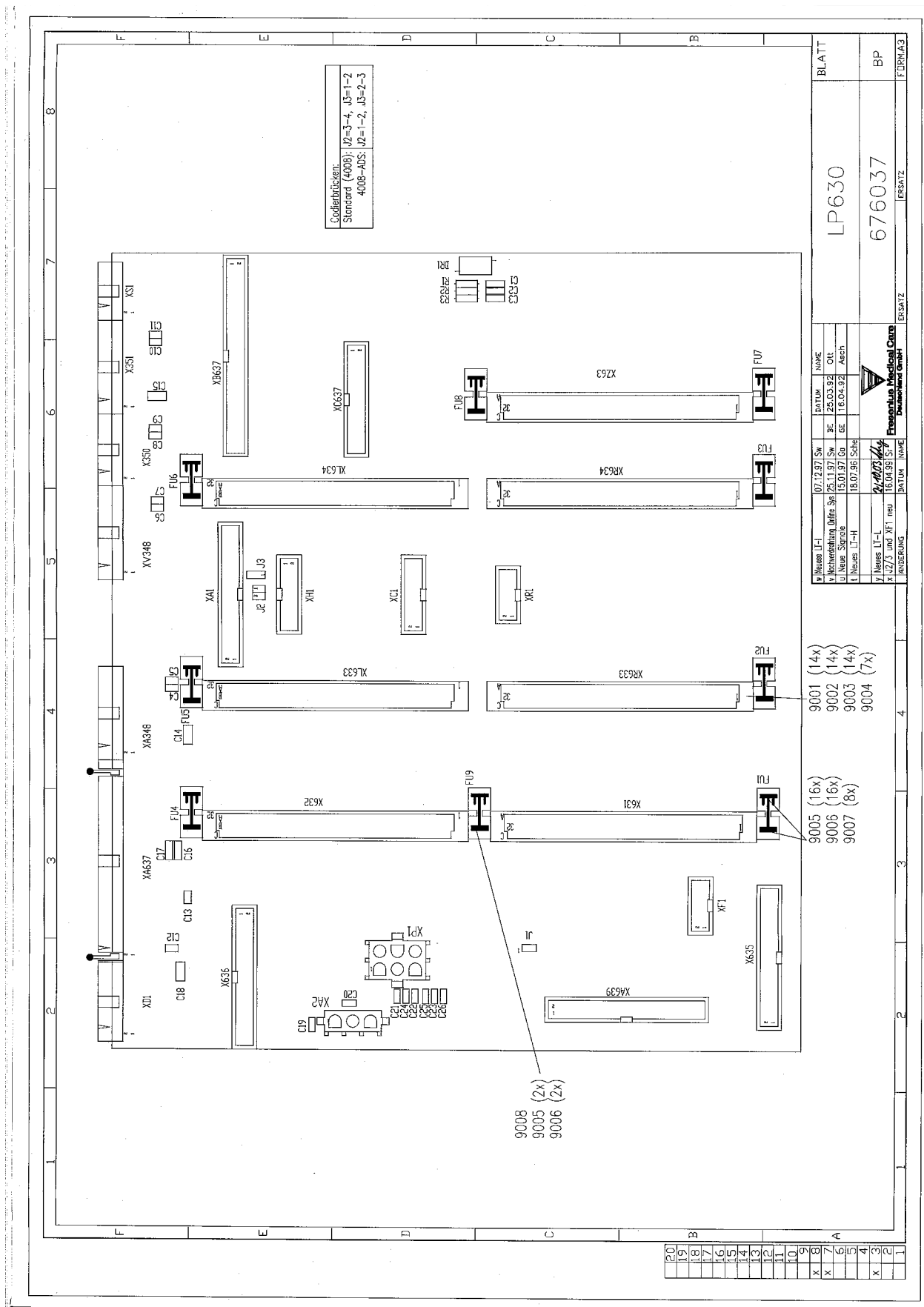

8.9 P.C.B. LP 631 CPU 1

Fig.: Block diagram P.C.B. LP 631 CPU 1

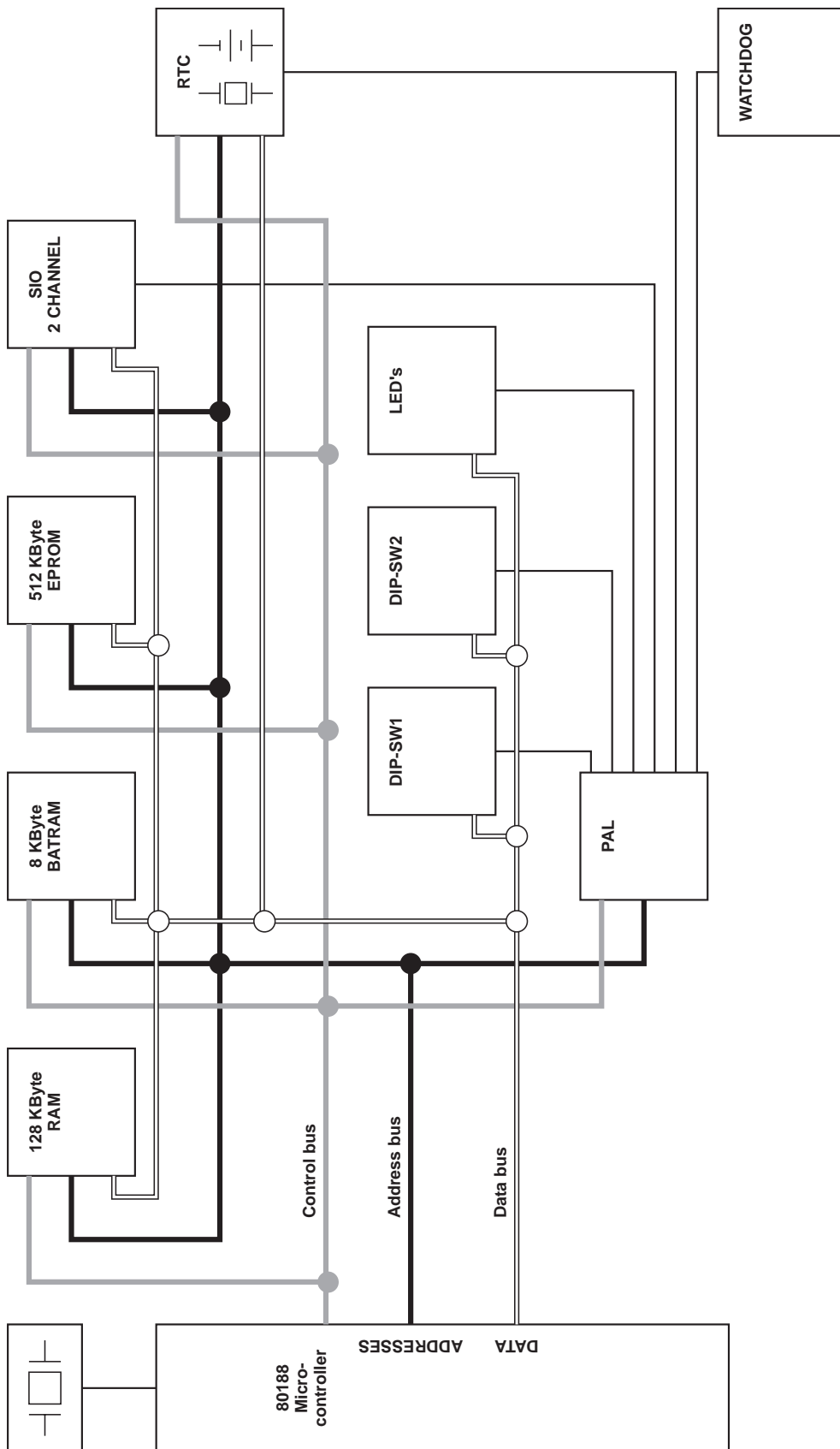

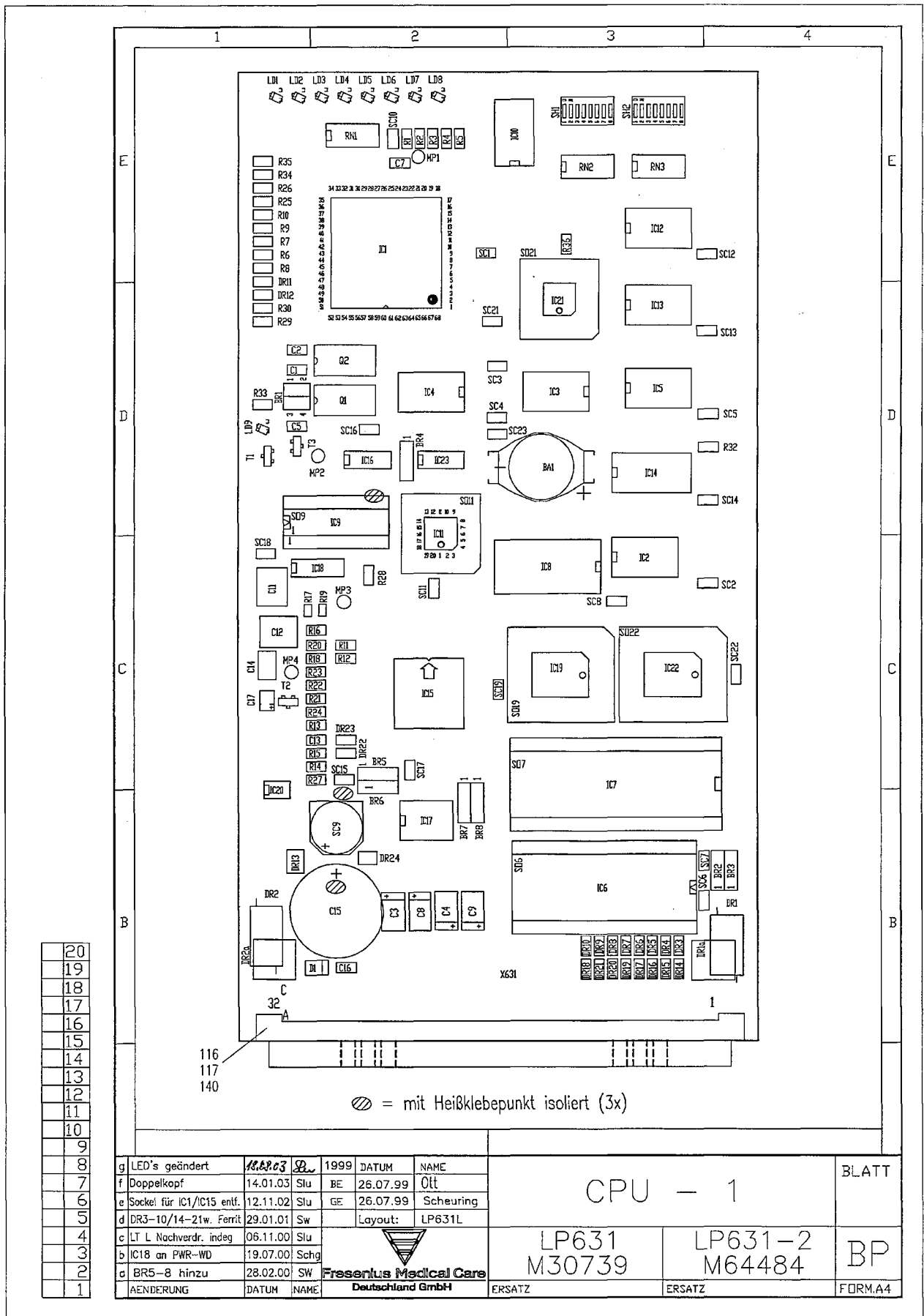

20
19
18
17
16
15
14
13
12
11
10
9
8
7
6
5
4
3
2
1

g	LED's geändert	14.01.03	Slu	1999	DATUM	NAME	CPU - 1		BLATT
f	Doppelkopf	14.01.03	Slu	BE	26.07.99	Ott			
e	Socket für IC1/IC15 entf.	12.11.02	Slu	GE	26.07.99	Scheuring			
d	DR3-10/14-21w. Ferrit	29.01.01	Sw			Layout: LP631L			
c	LT L Nachverdr. indog	06.11.00	Slu				LP631	LP631-2	BP
b	IC18 an PWR-WD	19.07.00	SchG				M30739	M64484	
a	BR5-8 hinzu	28.02.00	SW						
	AENDERUNG	DATUM	NAME	Fresenius Medical Care Deutschland GmbH			ERSATZ	ERSATZ	FORM.A4

8.10 P.C.B. LP 632 CPU 2

Fig.: Block diagram P.C.B. LP 632 CPU 2

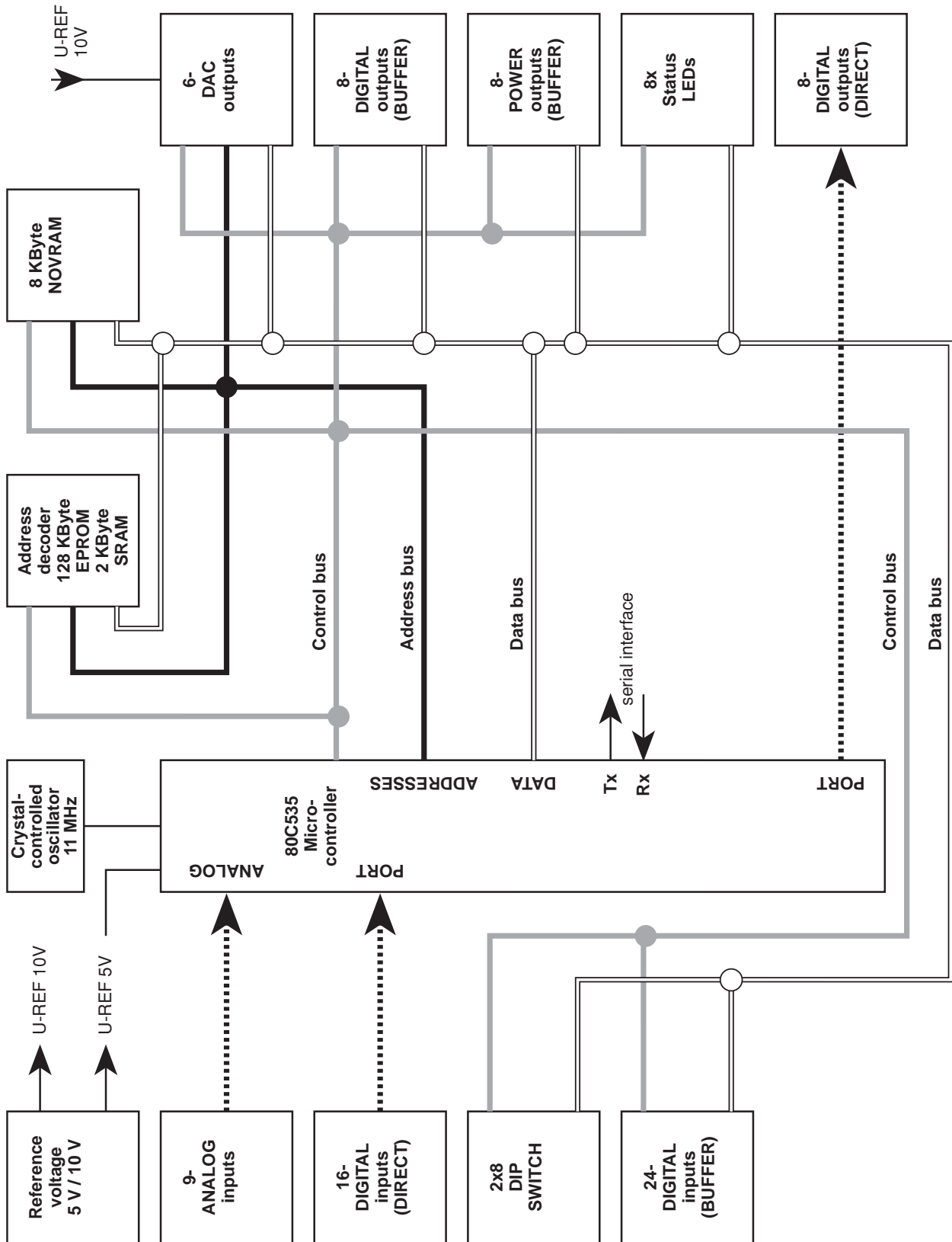

20
19
18
17
16
15
14
13
12
11
10
9
8
7
6
5
4
3
2
1

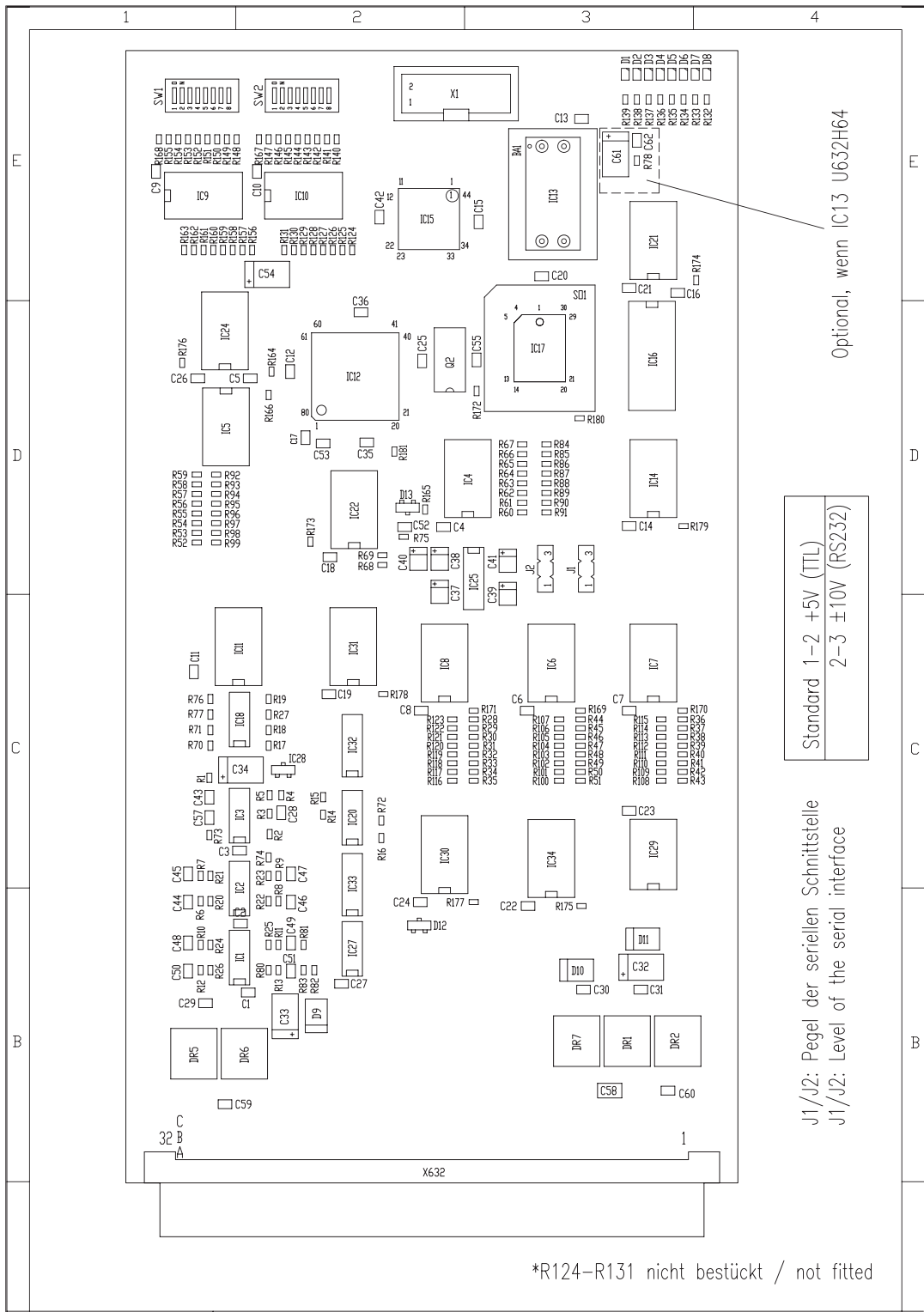

*R124-R131 nicht bestückt / not fitted

Standard 1-2 +5V (TTL)
2-3 ±10V (RS232)

J1/J2: Pegel der seriellen Schnittstelle
J1/J2: Level of the serial interface

Optional, wenn IC13 U632H64

			DATUM	NAME	CPU2 LP632	BLATT
			BE	24.02.99		
e	R181 neu / LT-L	20.08.07	GE	03.03.99	Schg	
d	neues LT-K	01.08.05	Schg	Layout:	LP632 L	
c	IC16 u. LED geändert	18.08.03	Slu			
b	Sockel IC12 entf.	12.11.02	Slu			
a	neues LT-J/SMT	04.04.00	Schg			
ÄNDERUNG			DATUM	NAME	ERSATZ	FORM.A4



M38975

8.11 P.C.B. LP 633 Input board

Fig.: Block diagram P.C.B. LP 633

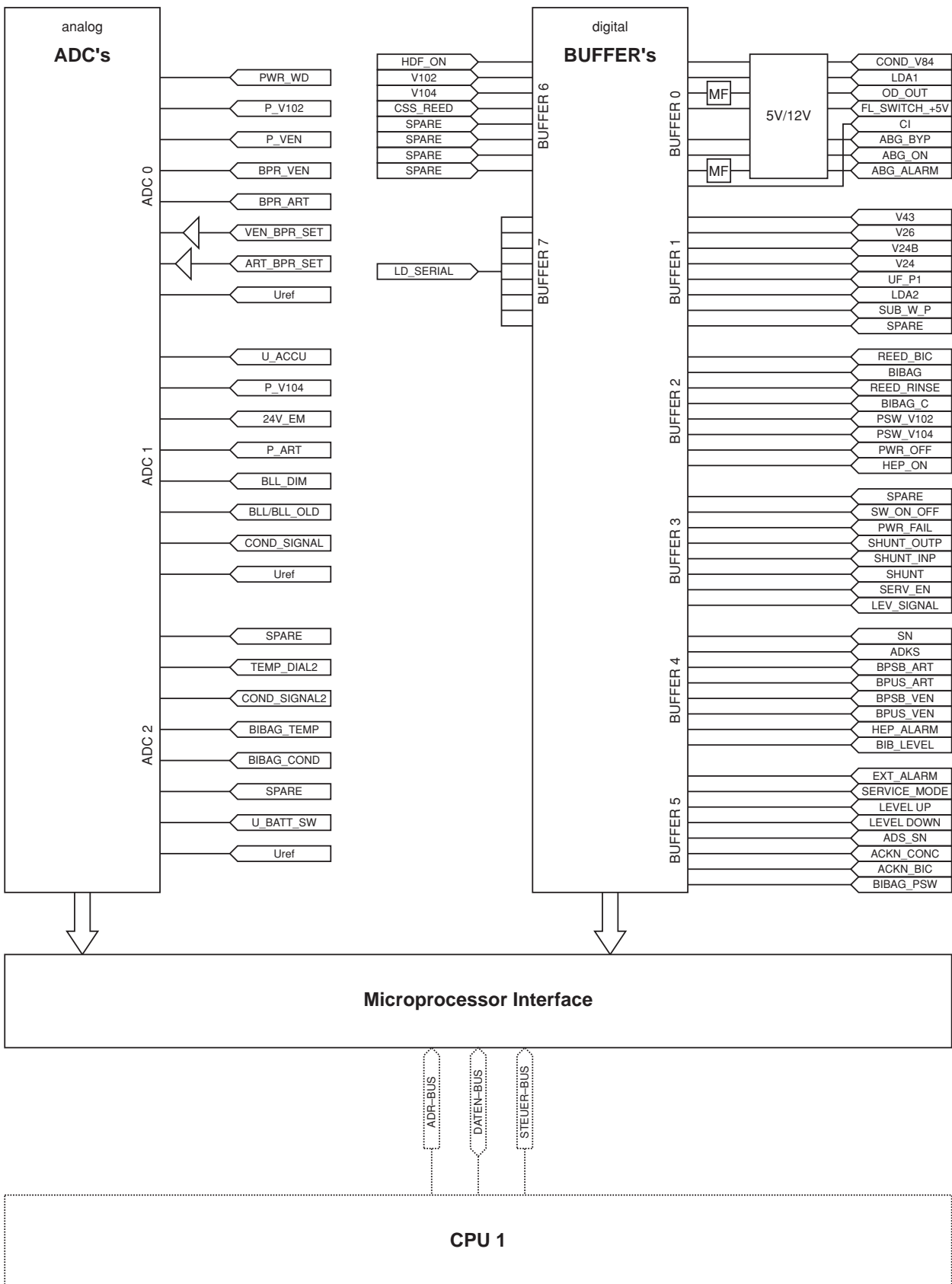

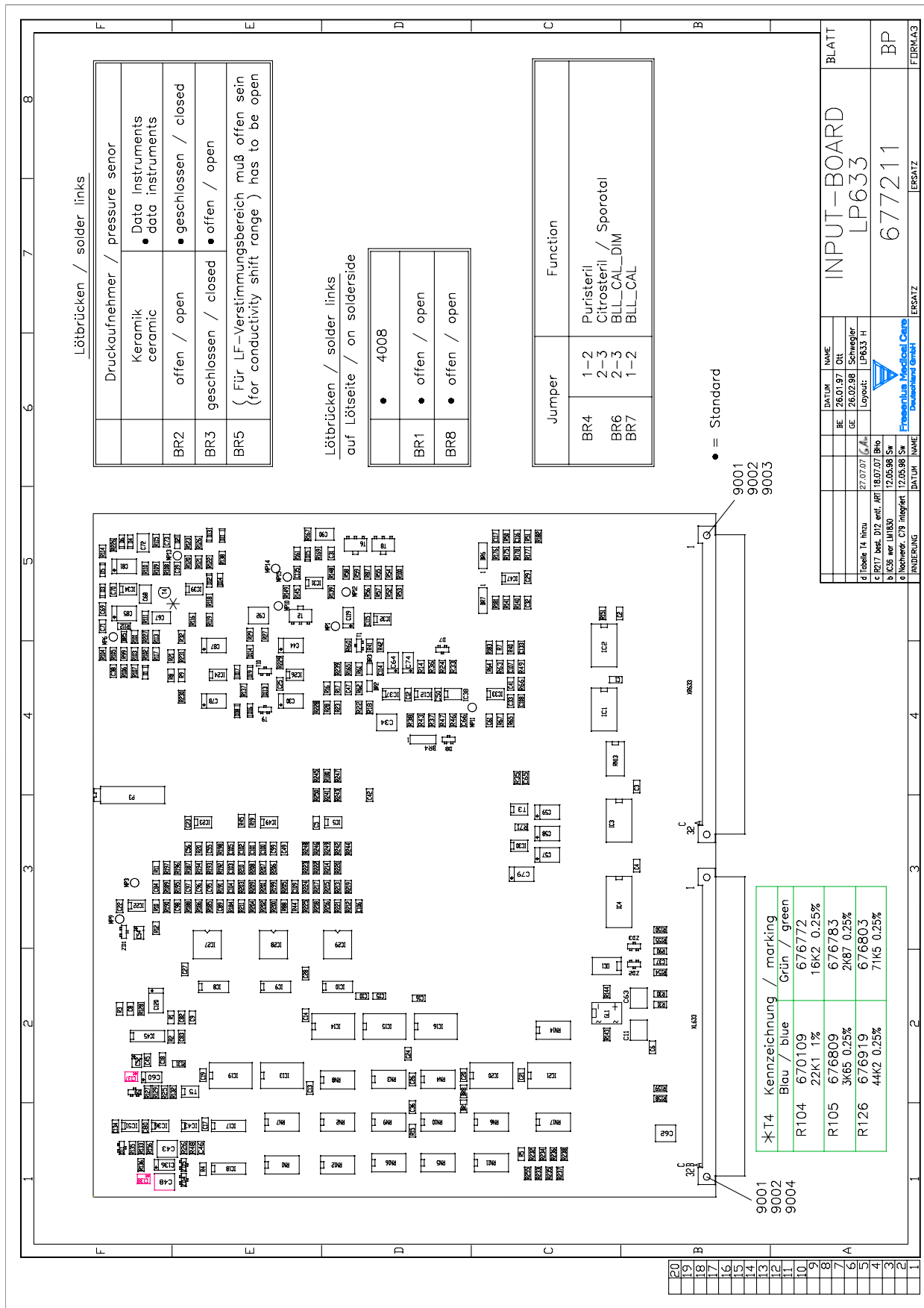

Lötbrücken / solder links

Druckaufnehmer / pressure sensor	
Keramik ceramic	Data Instruments data instruments
BR2	• offen / open
BR3	• geschlossen / closed
BR5	• offen / open

(Für LF-Verstimmungsbereich muß offen sein (for conductivity shift range) has to be open

Lötbrücken / solder links auf Lötseite / on solder side

• 4008	
BR1	• offen / open
BR8	• offen / open

Jumper	Function
BR4	1-2 Puristeril / Sporotal
BR6	2-3 Citrosteril / Sporotal
BR7	2-3 BLL_CAL_DIM
	1-2 BLL_CAL

• = Standard

*T4	Kennzeichnung / marking	Grün / green
R104	670109	676772
	22K1 1%	16K2 0.25%
R105	676809	676783
	3K65 0.25%	2K87 0.25%
R126	676919	676803
	44K2 0.25%	71K5 0.25%

9001
9002
9003

9001
9002
9004

DATEI	NAME	BLATT
BE	26.01.97	ORL
GE	26.02.99	Schwäger
Layout:	LP633 H	
d	Tabelle T4 hinzu	27.07.07
c	R217 best. D12, entf. ART	18.07.07
b	IC36 wer M1830	12.05.98
a	Nochwend. C79 inoptiert	12.05.98
ÄNDERUNG	NAME	ERSATZ
		ERSATZ
Fresenius Medical Care Deutschland GmbH		
INPUT-BOARD LP633		
677211		
BP		
FDRM.A3		

8.12 P.C.B. LP 634 Output board

Fig.: Block diagram P.C.B. LP 634 Output board

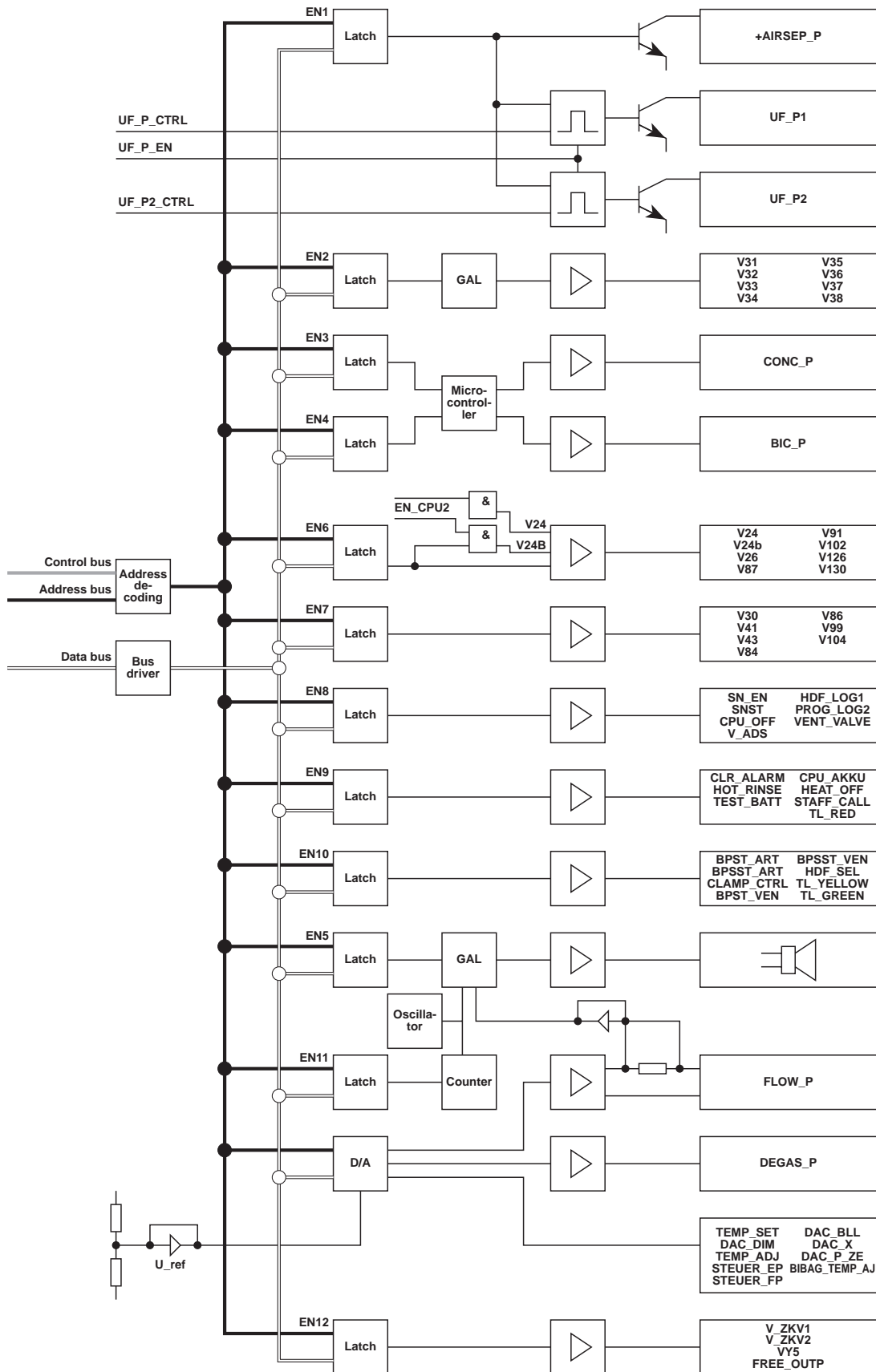

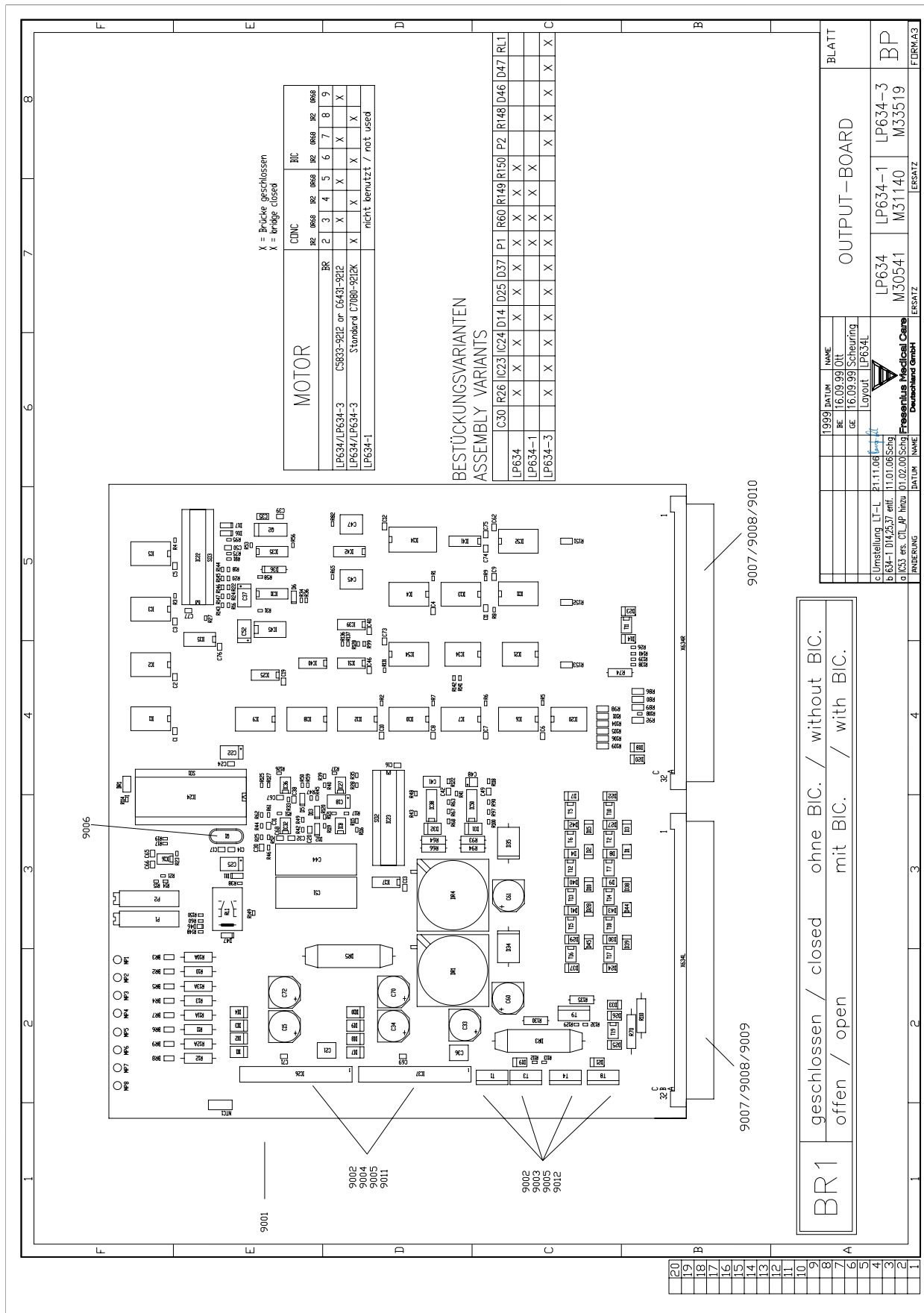

MOTOR

X = Brücke geschlossen
X = bridge closed

	CINC		BIC							
	BR	2	3	4	5	6	7	8	9	
LP634/LP634-3	C5833-922 or G6431-922	X	X	X	X	X	X	X	X	
LP634/LP634-3	Standard C7080-922K	X	X	X	X	X	X	X	X	
LP634-1										

nicht benutzt / not used

**BESTÜCKUNGSVARIANTEN
ASSEMBLY VARIANTS**

	C30	R26	IC23	IC24	D14	D25	D37	P1	R60	R149	R150	P2	R148	D46	D47	RL1
LP634	X	X	X	X	X	X	X	X	X	X	X	X	X	X	X	X
LP634-1	X	X	X	X	X	X	X	X	X	X	X	X	X	X	X	X
LP634-3	X	X	X	X	X	X	X	X	X	X	X	X	X	X	X	X

BR1 geschlossen / closed ohne BIC. / without BIC.
 offen / open mit BIC. / with BIC.

1999	DATUM	NAM	BLATT
BE	16.09.99	Olt	OUTPUT-BOARD
GE	16.09.99	Scheuring	
		Layout	LP634
			LP634 LP634-1 LP634-3
			M30541 M31140 M33519
			ERSATZ
			ERSATZ
			FORM A3

INBENUTZUNG	DATUM	NAM
c Umstellung LT-L	P1.11.08	Wingert
b B34-1 D14,23,7 entf.	11.01.06	Schig
g IC53 ers. C1L AP	01.02.00	Schig
		Fresenius Medical Care Deutschland GmbH

8.13 P.C.B. LP 635 Display board

Fig.: Block diagram P.C.B. LP 635 Display board

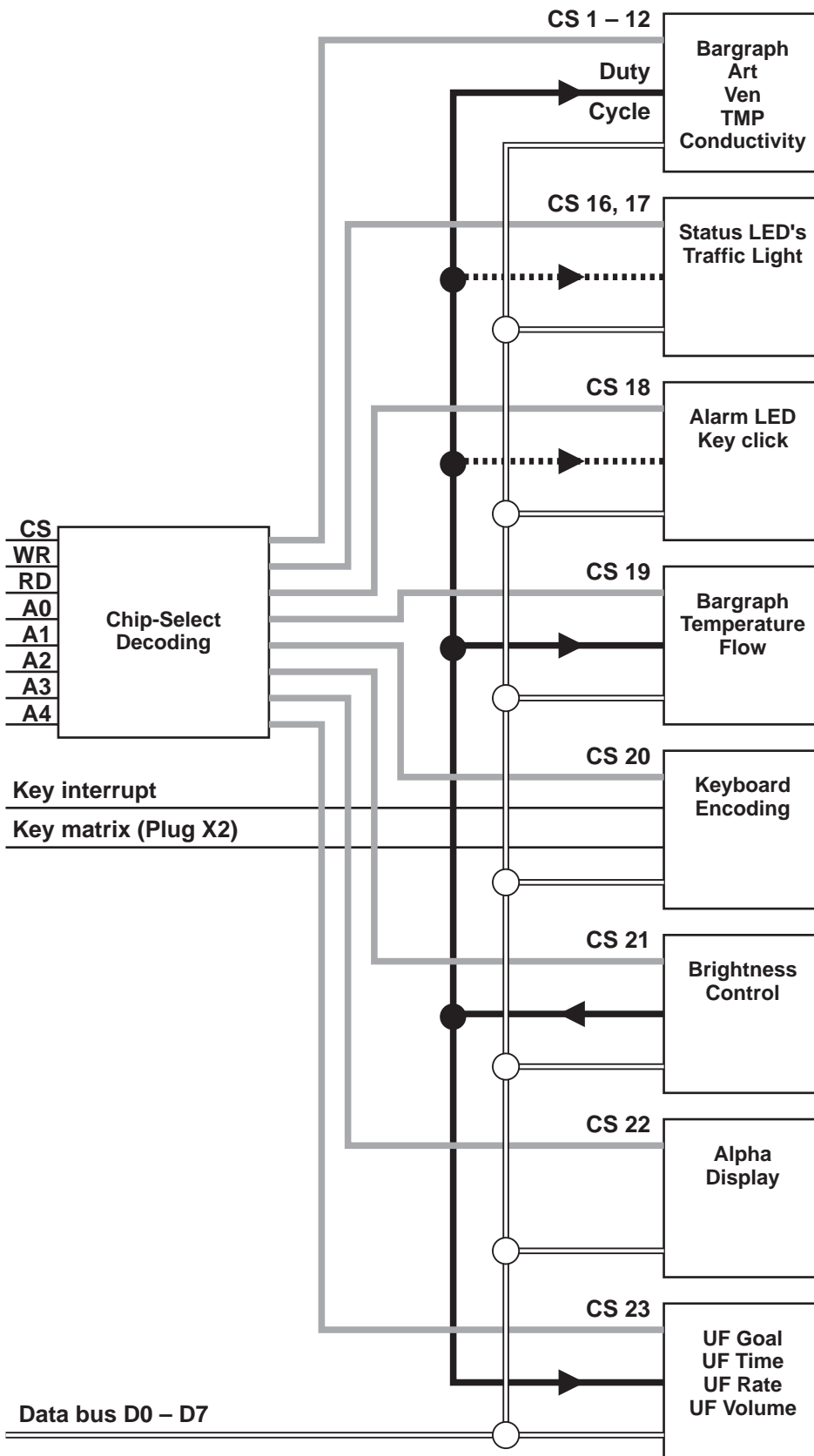

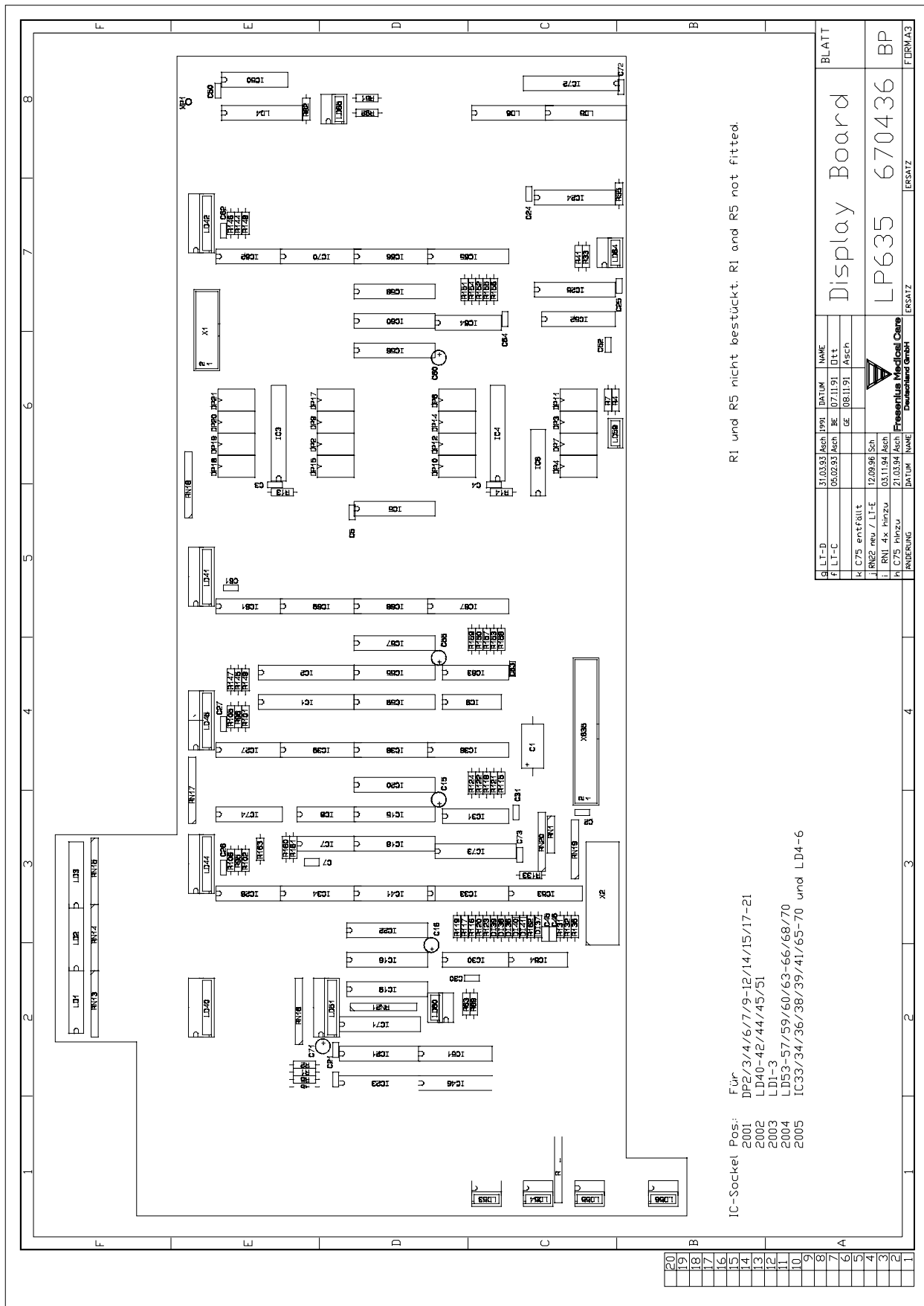

R1 und R5 nicht bestückt. R1 and R5 not fitted.

IC-Sockel Pos.:
 2001 DP2/3/4/6/7/9-12/14/15/17-21
 2002 LD40-42/44/45/51
 2003 LD1-3
 2004 LD53-57/59/60/63-66/68/70
 2005 IC33/34/36/38/39/41/65-70 und LD4-6

GRUNDZUG	DATUM	NAMEN
G LT-D	31.03.93	Asch, Jpsl
F LT-C	05.02.93	Asch, BE
	07.11.91	Dtt
	08.11.91	Asch
	GE	
M C75 erfüllt	12.09.96	Sch
J RN2 neu / LT-E	03.11.94	Asch
I RN1 4x hinzu	21.03.94	Asch
M C75 hinzu		

ANFORDERUNG	DATUM	NAMEN	ERSATZ	FORM.A3
Fresenius Medical Care Deutschland GmbH				
Display Board				
LP635 670436 BP				
ERSATZ				

20
19
18
17
16
15
14
13
12
11
10
9
8
7
6
5
4
3
2
1

8.14 P.C.B. LP 636 External connectors

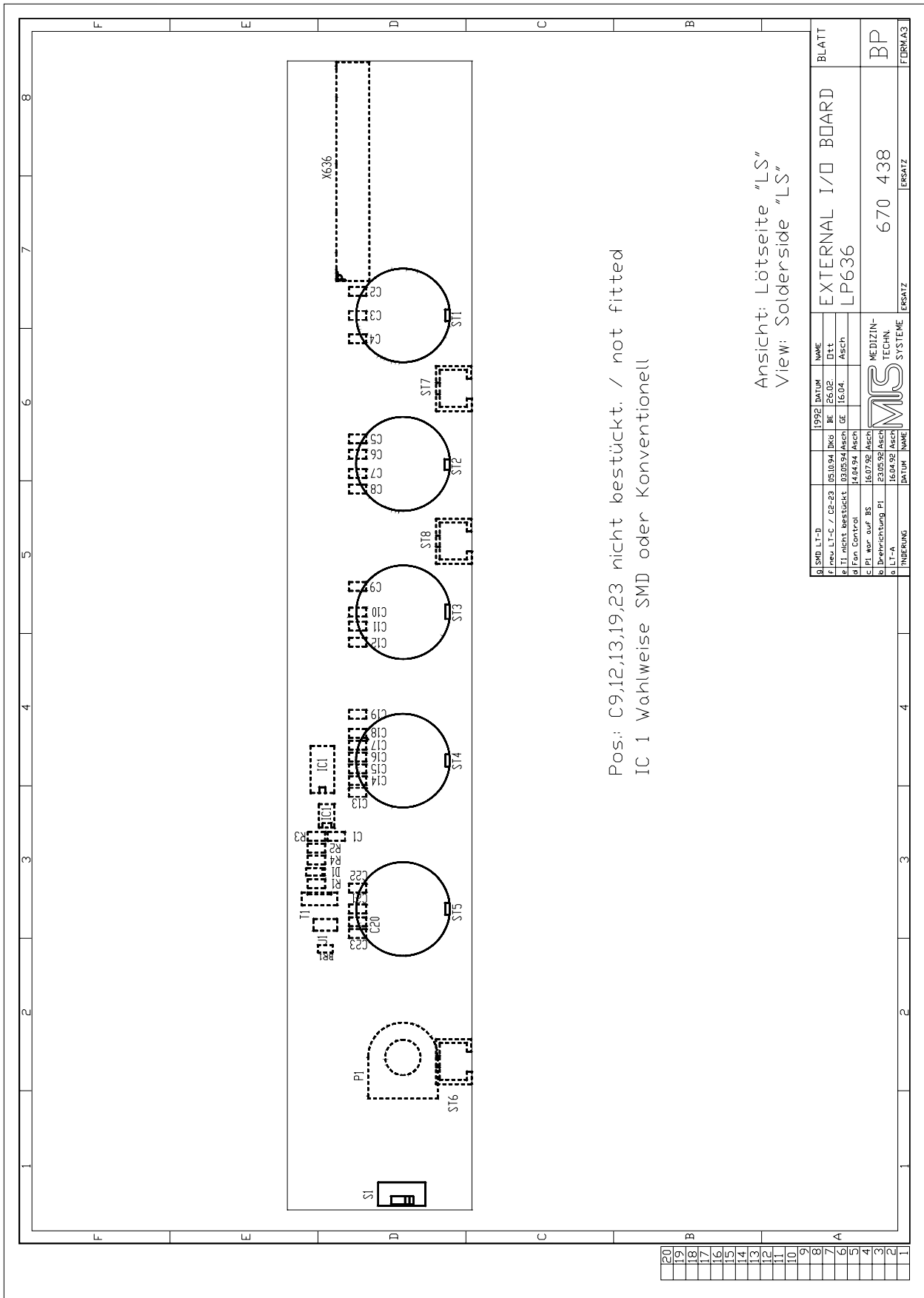

8.16 P.C.B. LP 644-4 Display board (HEP)

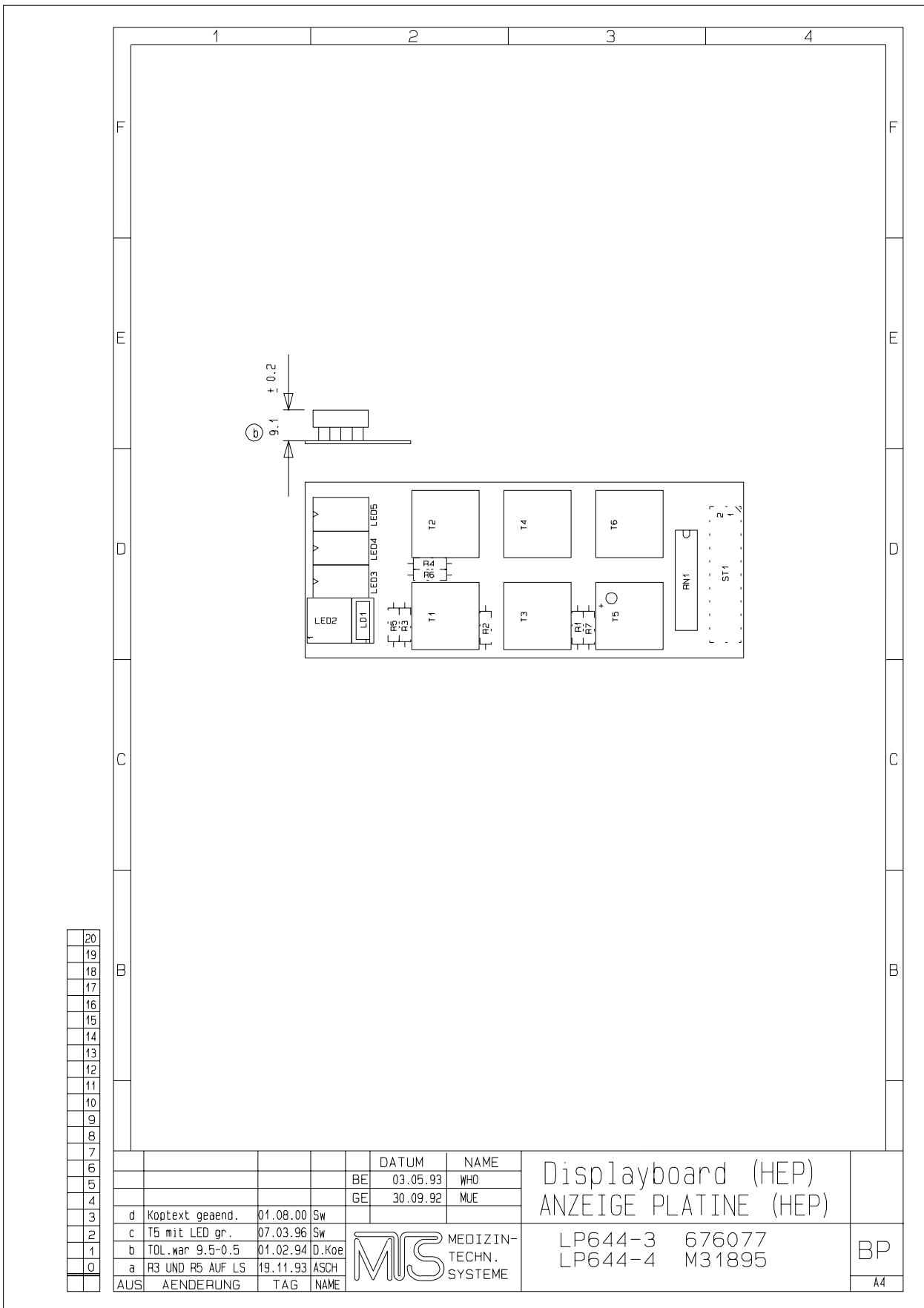

8.17 P.C.B. LP 645 Position sensor membrane pump

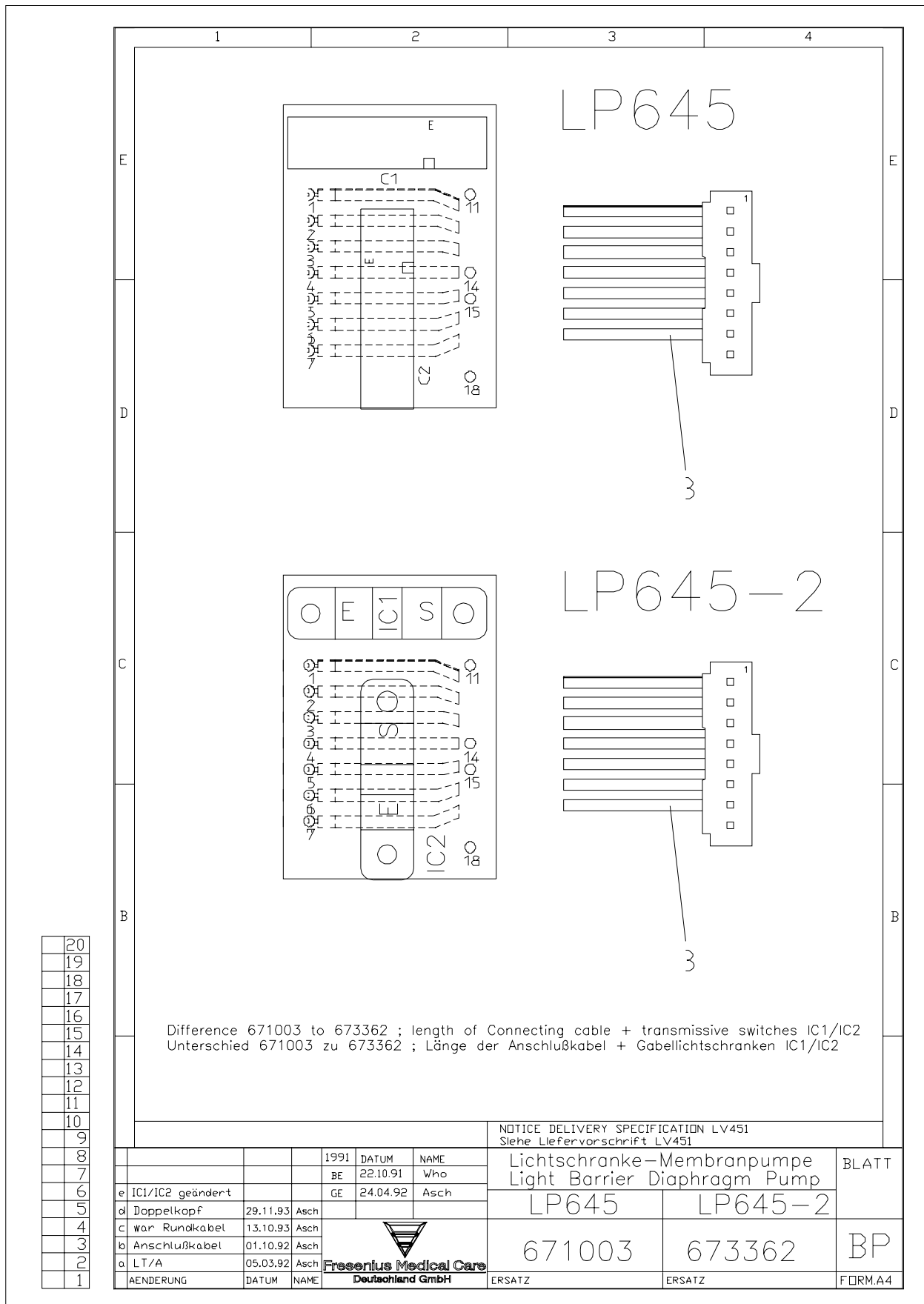

8.18 P.C.B. LP 649-2 Display board (4008 B/S)

Fig.: Block diagram P.C.B. LP 649-2 Display board

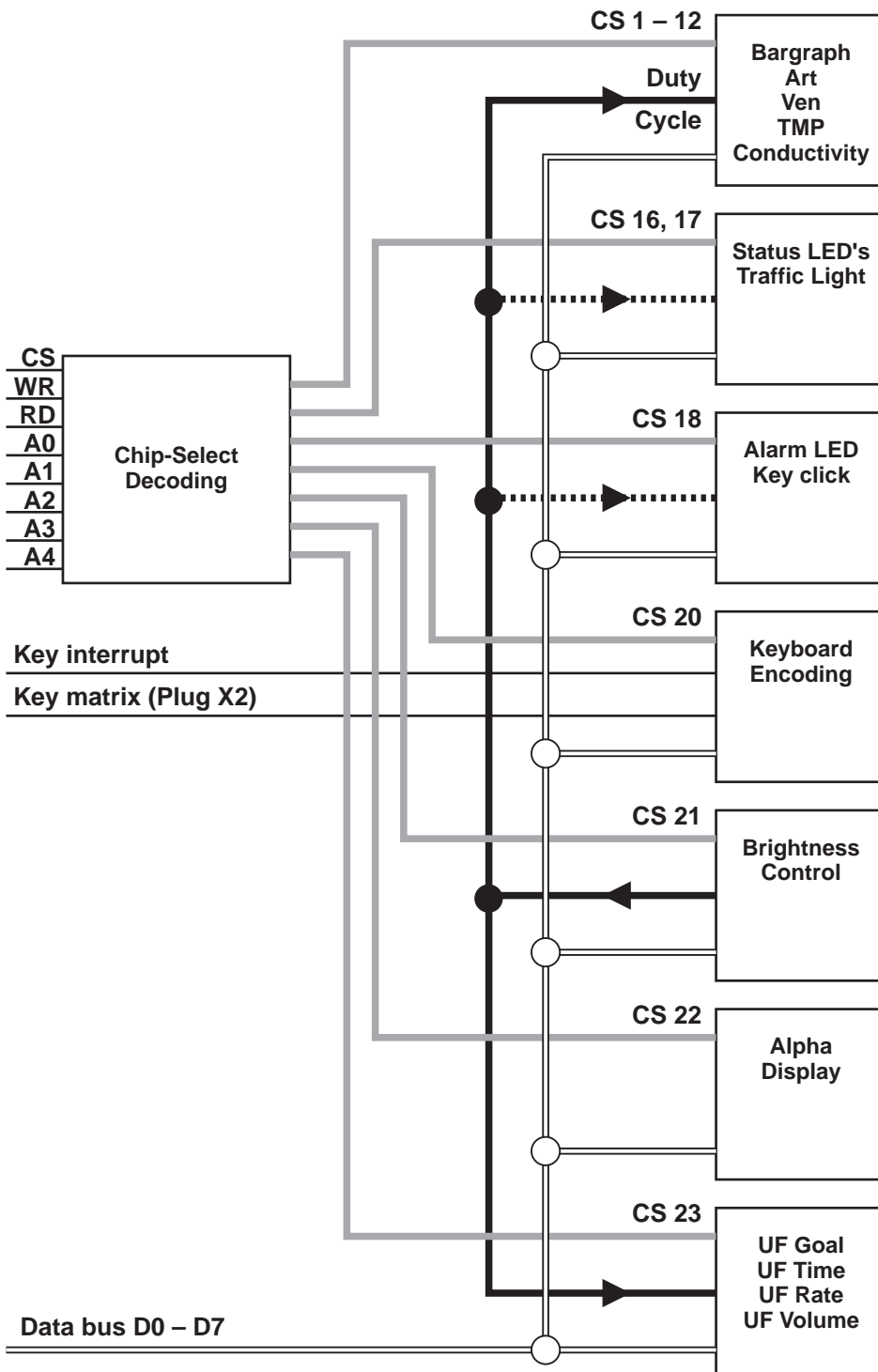

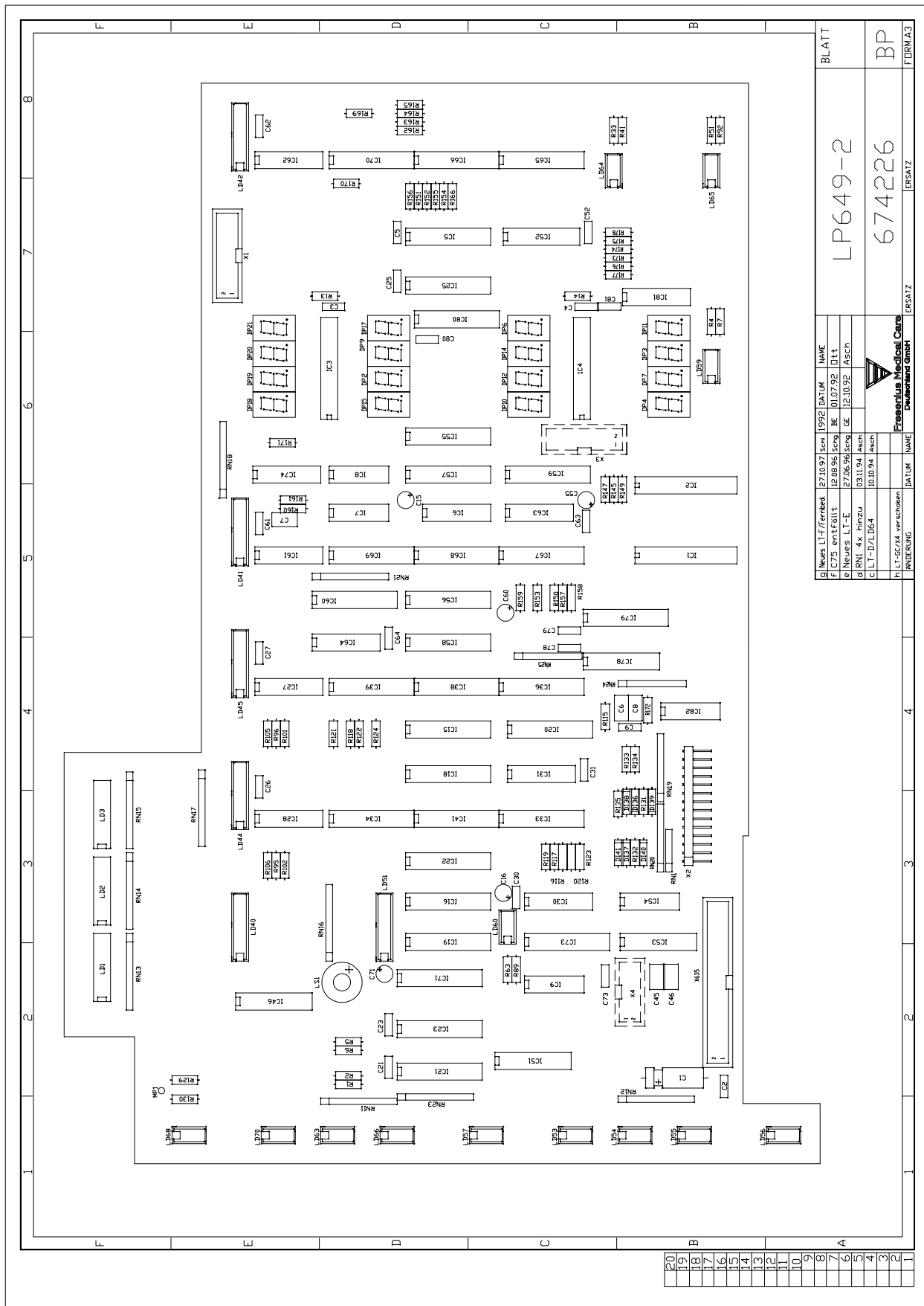



g) Neues LT-E/verbod	27.10.97	Scn	1992	DA/UM	NAME
f) Neues LT-E	12.08.96	Scng	BE	01.07.92	Ditt
e) Neues LT-E	27.06.96	Scng	GE	12.10.92	Asch
d) RNI 4x hinzu	03.11.94	Asch			
c) LT-D/L.DG4	10.10.94	Asch			
b) LT-GC7/4, ver-schoben					
a) RINDECKUNG					

LP649-2		ERSATZ		FORM.A3	
674226		ERSATZ		BP	
 Fresenius Medical Care Deutschland GmbH					

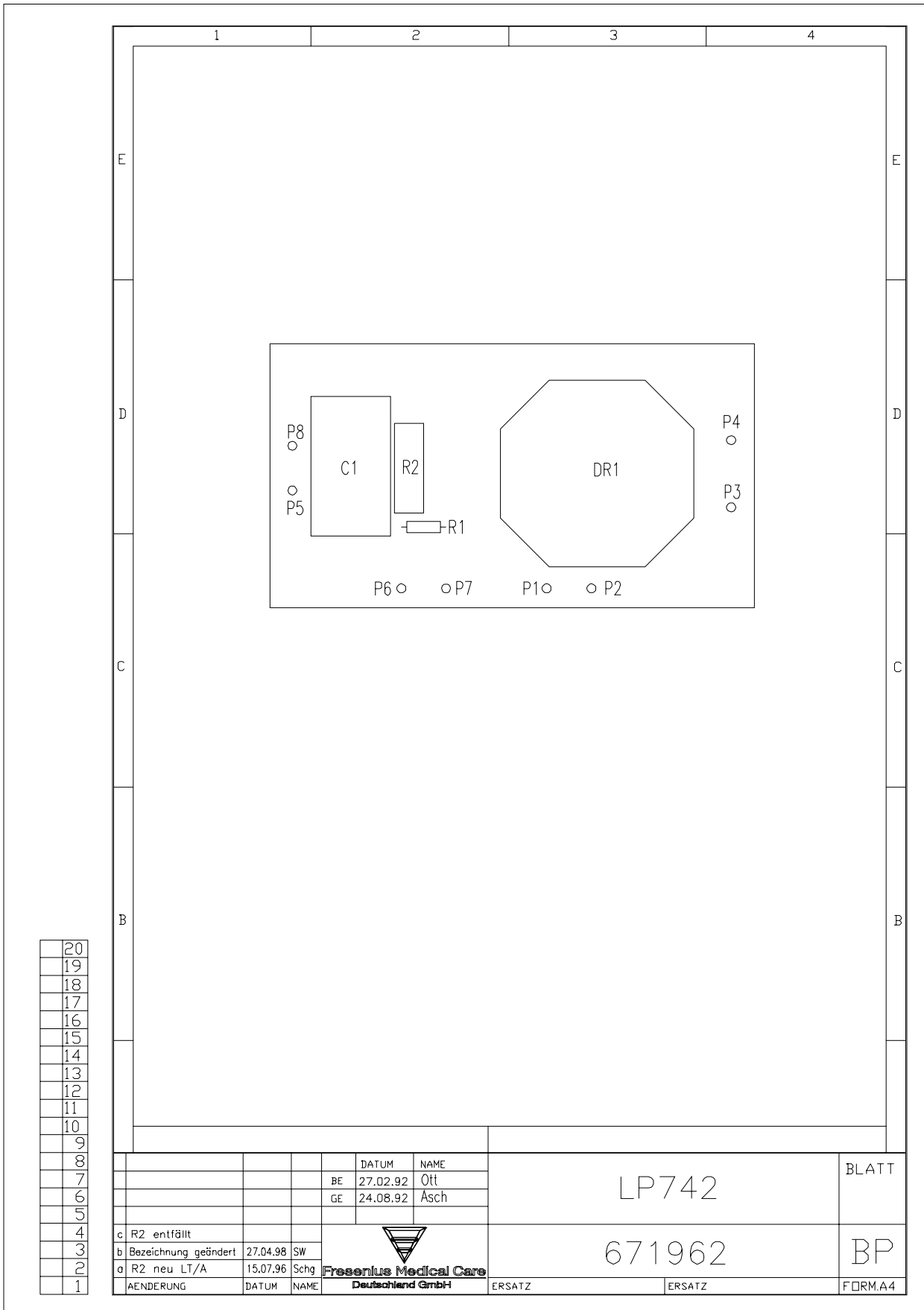
8.19 P.C.B. LP 742 Interference filter



20
19
18
17
16
15
14
13
12
11
10
9
8
7
6
5
4
3
2
1

				DATUM	NAME	LP742	BLATT
			BE	27.02.92	Ott		
			GE	24.08.92	Äsch		
						671962	BP
c	R2 entfällt						
b	Bezeichnung geändert	27.04.98	SW				
a	R2 neu LT/A	15.07.96	Schg				
	ÄNDERUNG	DATUM	NAME			ERSATZ	FORM.A4

8.20 P.C.B. LP 748 Display board (BP)

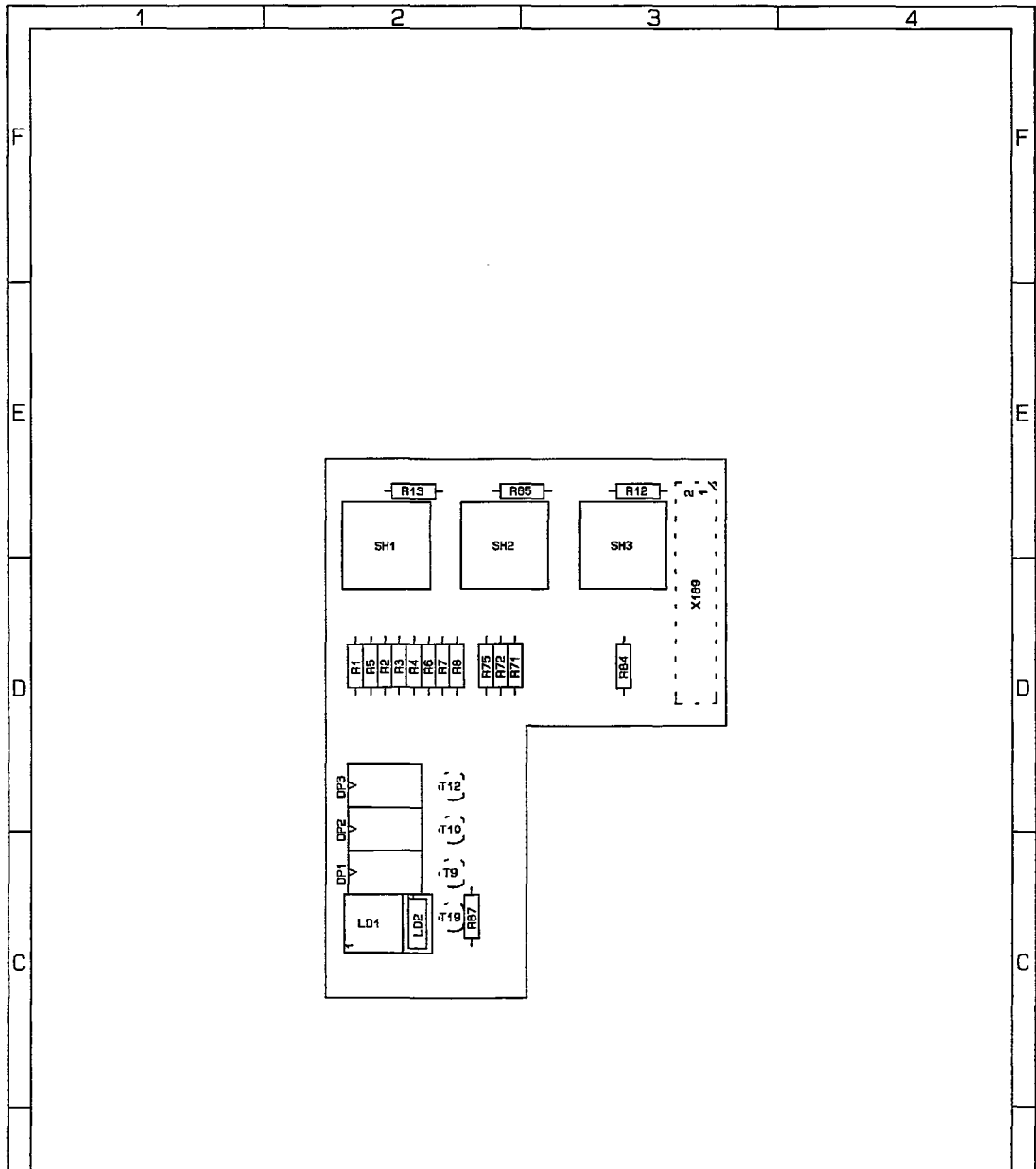

HOEHE VON LD1, LD2; DP1-DP3, SH1-SH3: 8.8 ± 0.2 mm
 HEIGHT OF LD1, LD2; DP1-DP3, SH1-SH3: 8.8 ± 0.2 mm

20
19
18
17
16
15
14
X 13
X 12
11
10
9
X 8
X 7
X 6
X 5
4
X 3
2
1
0

				DATUM	NAME	DISPLAY BOARD LP748	BP
				BE 29.01.93	WHD		
				GE 15.03.93	ASCH		
c	HOEHE war 9.5	27.01.94	2.6			672421	BP
b	LT-B (LP-BREITE)	18.11.93	KOE				
a	EINBAUHOEHE	22.10.93	ASCH				
AUS	AENDERUNG	TAG	NAME				A4



8.21 P.C.B. LP 763 Multi interface board (COMMCO III)

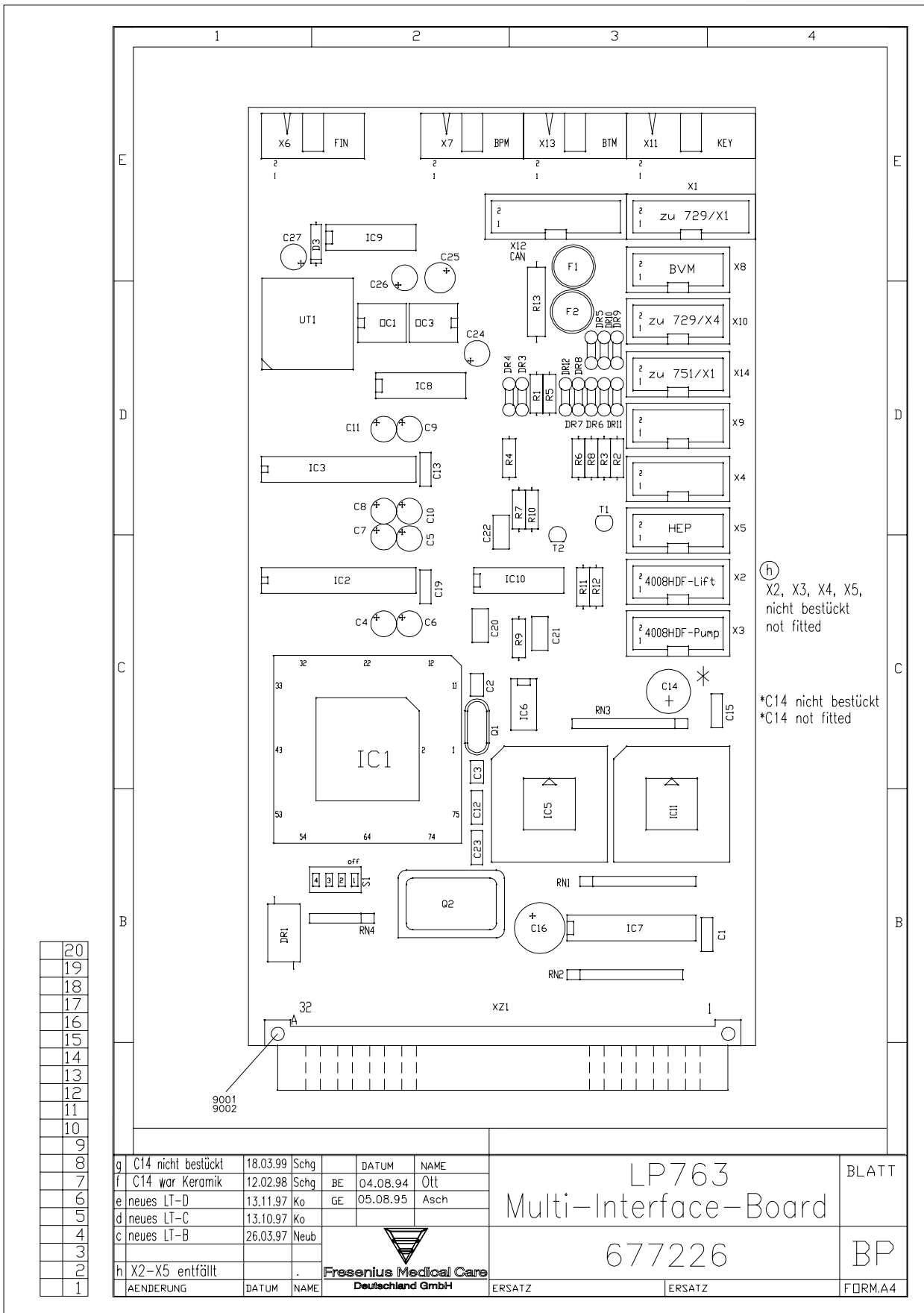

20
19
18
17
16
15
14
13
12
11
10
9
8
7
6
5
4
3
2
1

g	C14 nicht bestückt	18.03.99	Schq		DATUM	NAME
f	C14 war Keramik	12.02.98	Schq	BE	04.08.94	Ott
e	neues LT-D	13.11.97	Ko	GE	05.08.95	Asch
d	neues LT-C	13.10.97	Ko			
c	neues LT-B	26.03.97	Neub			
h	X2-X5 entfällt					
	ÄNDERUNG	DATUM	NAME			



LP763 Multi-Interface-Board		BLATT
677226		BP
ERSATZ	ERSATZ	FORM.A4

8.22 P.C.B. LP 922 Display board (4008 S)

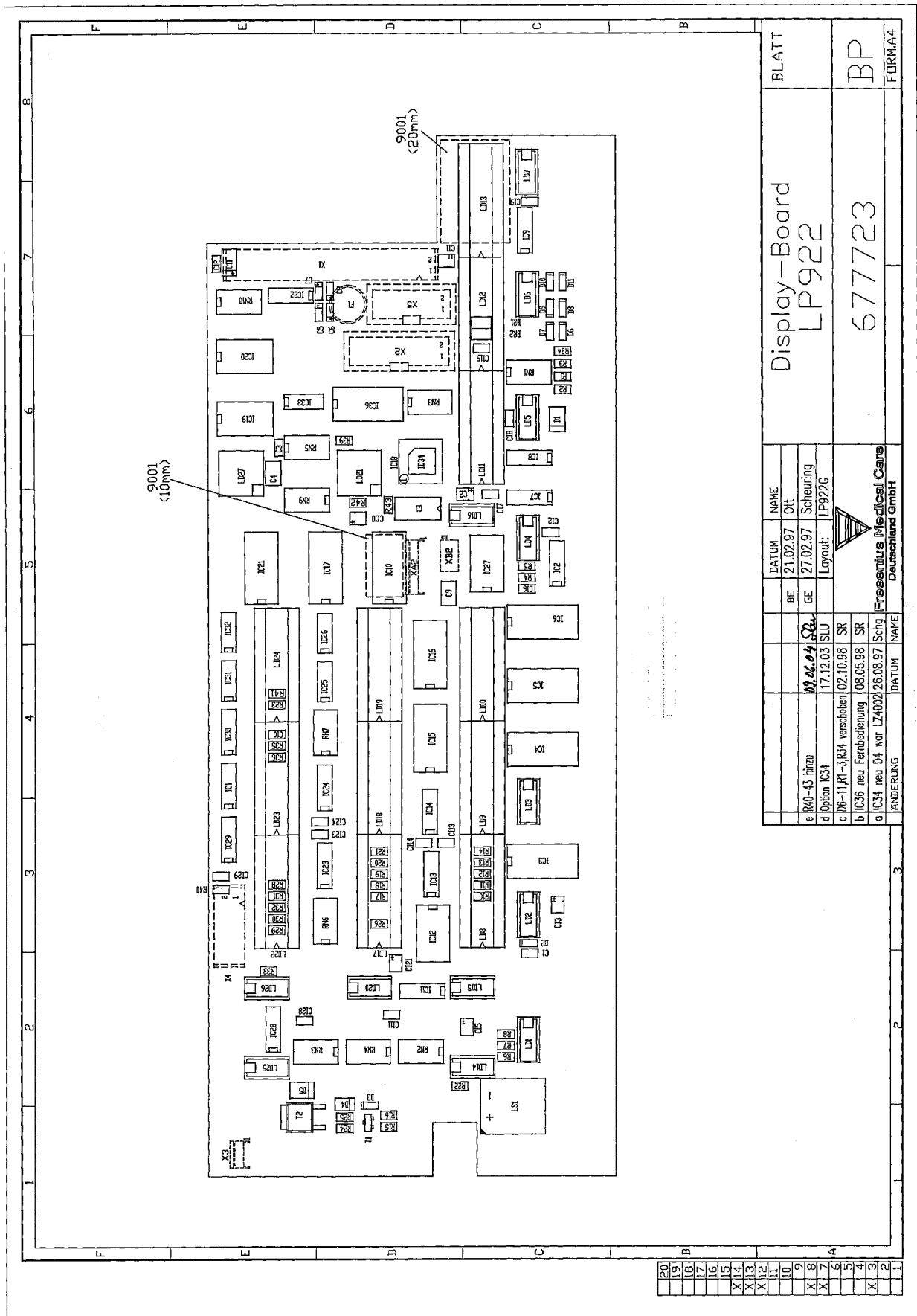

BLATT		Display-Board LP922		FORMA4	
DATE		21.02.97		BP	
BY		GE		677723	
NAME		Scheuring		Fresenius Medical Care Deutschland GmbH	
LAYOUT		LP922G			
DATE		17.12.03			
BY		SR			
NAME		Schg			
DATE		08.05.98			
BY		SR			
NAME		Schg			
DATE		26.08.97			
BY		SR			
NAME		Schg			
DATE		02.10.98			
BY		SR			
NAME		Schg			
DATE		17.12.03			
BY		SR			
NAME		Schg			
DATE		27.02.97			
BY		GE			
NAME		Scheuring			
DATE		21.02.97			
BY		GE			
NAME		Scheuring			

20	X
19	X
18	X
17	X
16	X
15	X
14	X
13	X
12	X
11	X
10	X
9	X
8	X
7	X
6	X
5	X
4	X
3	X
2	X
1	X

8.23 P.C.B. LP 923 Traffic light (4008 H/S)

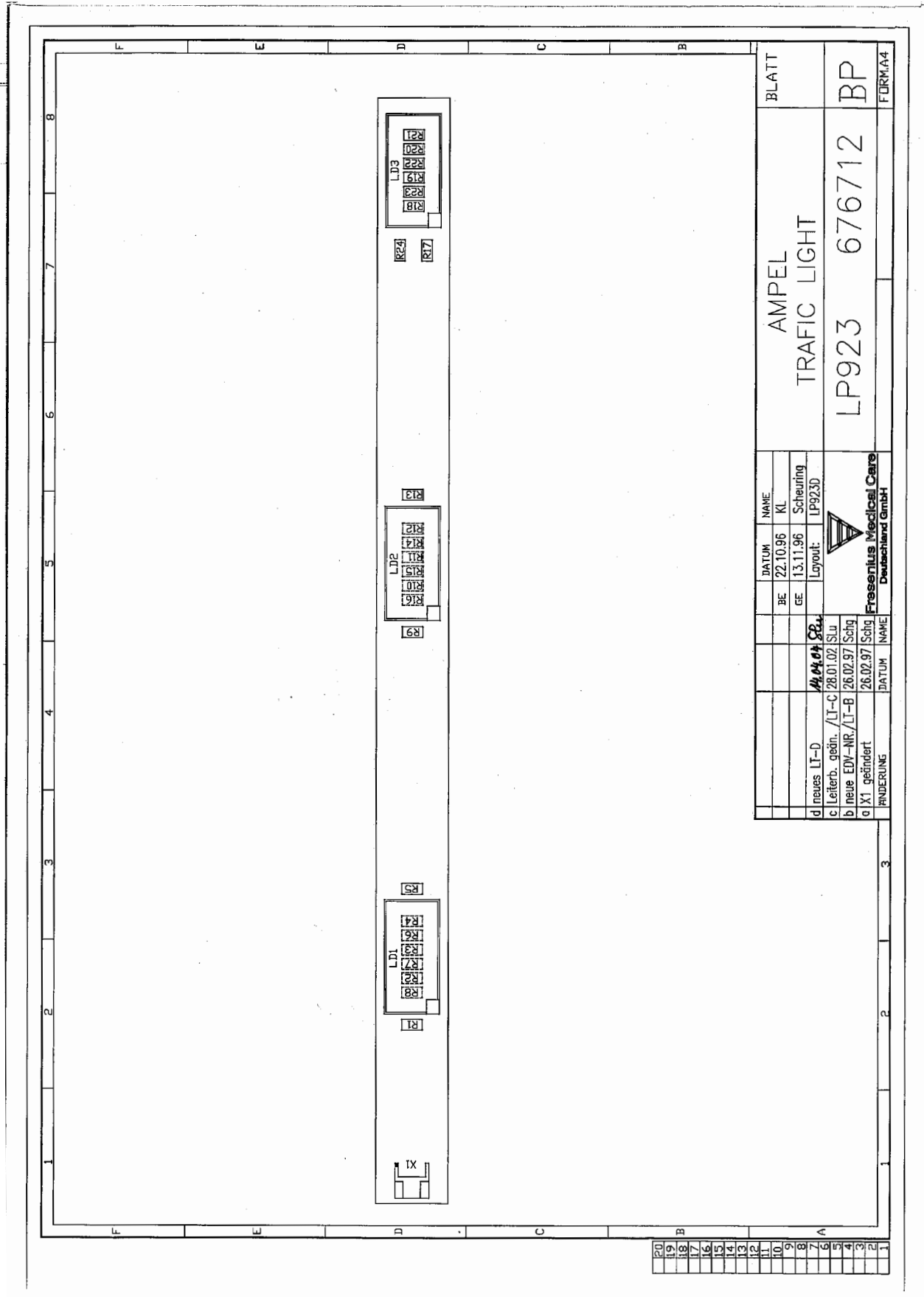

BLATT		AMPEL TRAFIC LIGHT	
LP923		676712	
BP		FORM A4	
DATUM	NAME	DATUM	NAME
BE 22.10.96	KL	BE 22.10.96	KL
GE 13.11.96	Scheuring	GE 13.11.96	Scheuring
	Layout: LP923D		Layout: LP923D
d neues LI-D	11.04.98		
c Leiterb. geänd. / LI-C	26.01.02	SLu	
b neue EDV-NR. / LI-B	26.02.97	Schlg	
a X1 geändert	26.02.97	Schlg	
ÄNDERUNG	DATUM	ÄNDERUNG	DATUM
		Fresenius Medical Care Deutschland GmbH	

8.24 P.C.B. LP 924 Display board (4008 H)

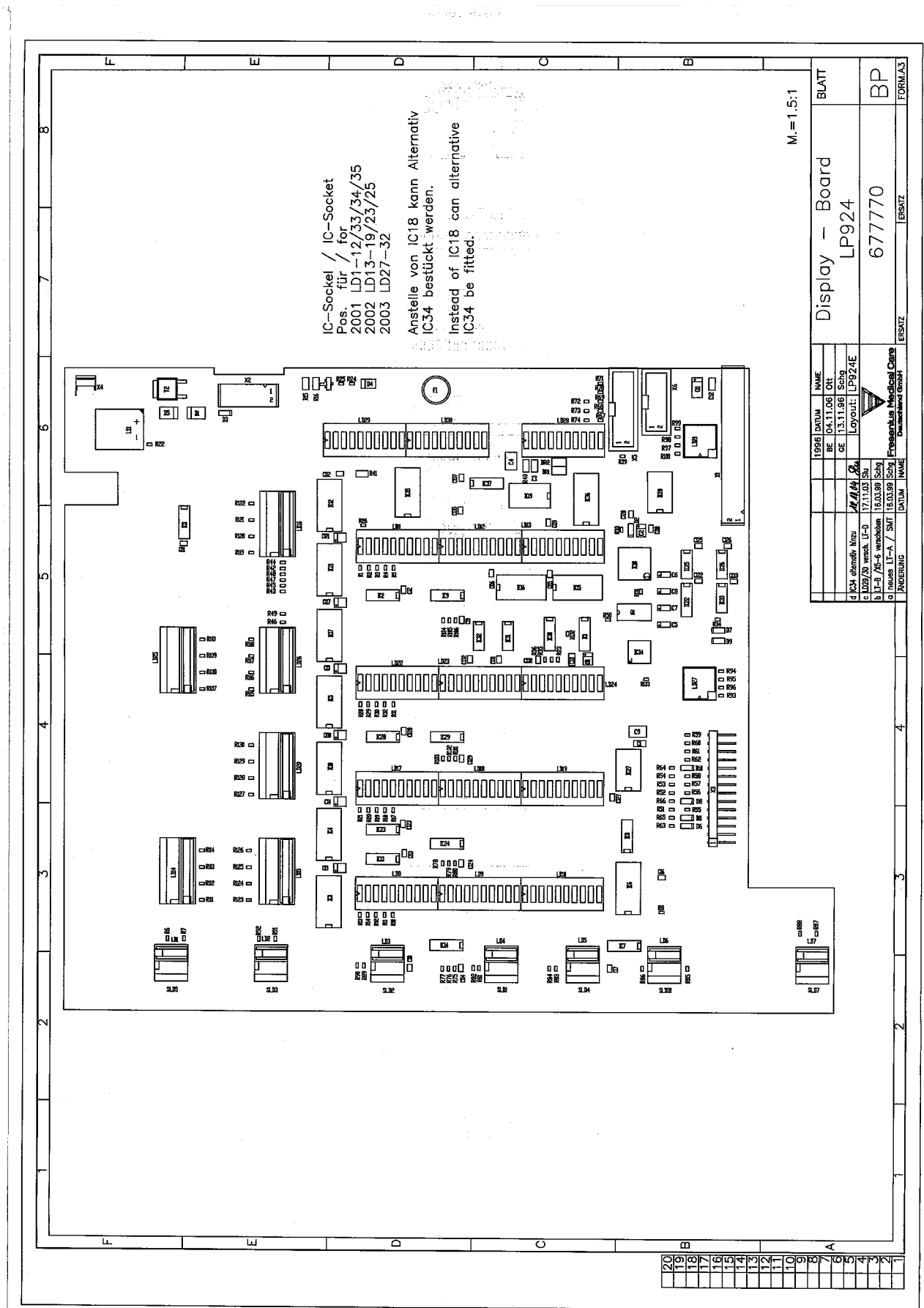

8.25 P.C.B. LP 941 Hydraulics processor

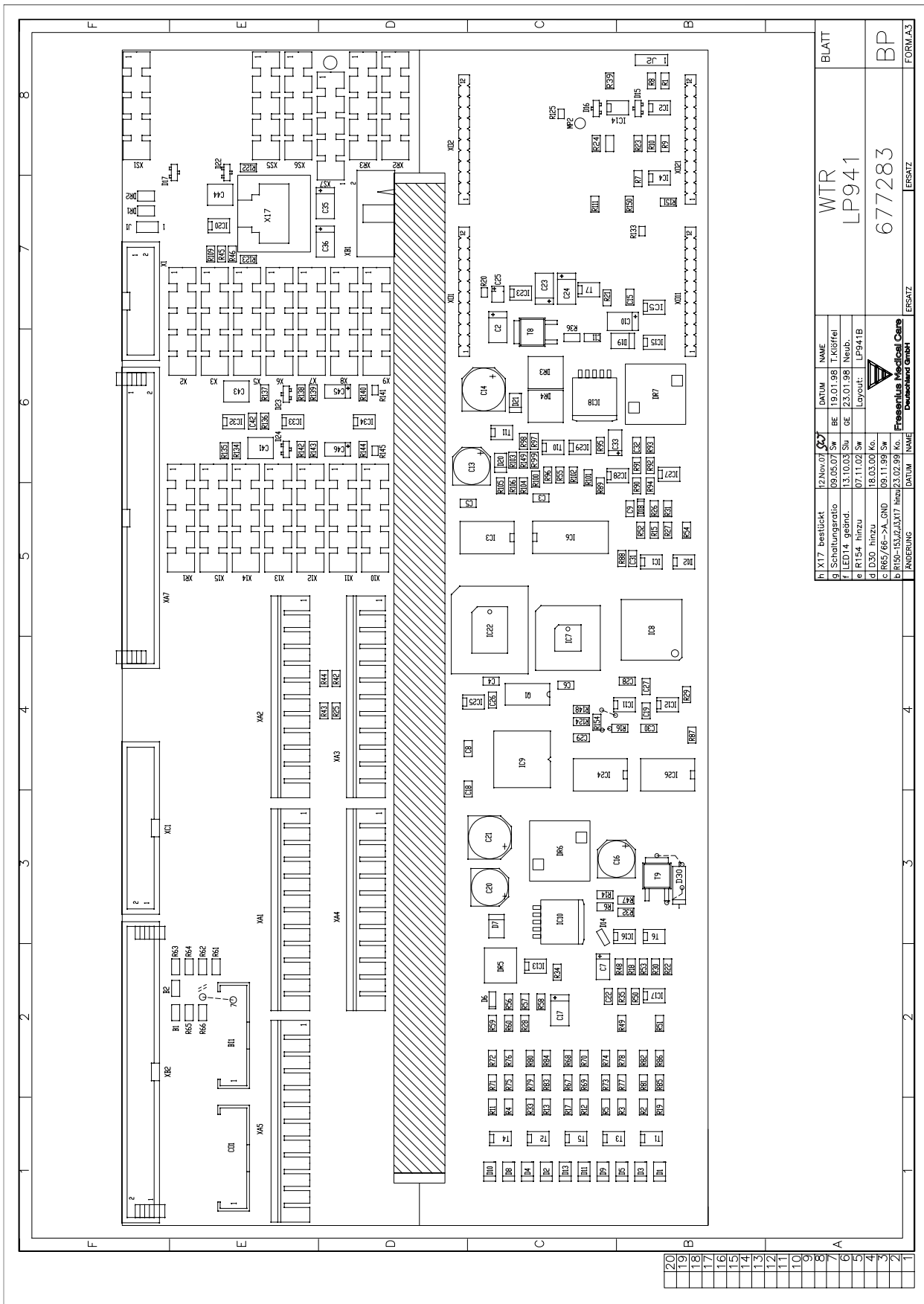

h) X17 bestückt	12.Nov.07	GE	DATUM	NAME
i) Schaltungsverstoß	09.05.07	Sw	13.10.03	Su
j) LED14. abänd.	13.10.03	Su	07.11.03	Sw
k) FR154. hinzu	07.11.03	Sw	16.05.08	Ko.
l) D30. hinzu	16.05.08	Ko.	09.11.99	Sw
m) R85/66->A_GND	09.11.99	Sw	11.03.99	Ko.
n) R190->15k, J33X17	11.03.99	Ko.		

WTR LP941	BLATT
677283	ERSATZ
	FORM A3

8.26 Heater board (power supply unit 4008)

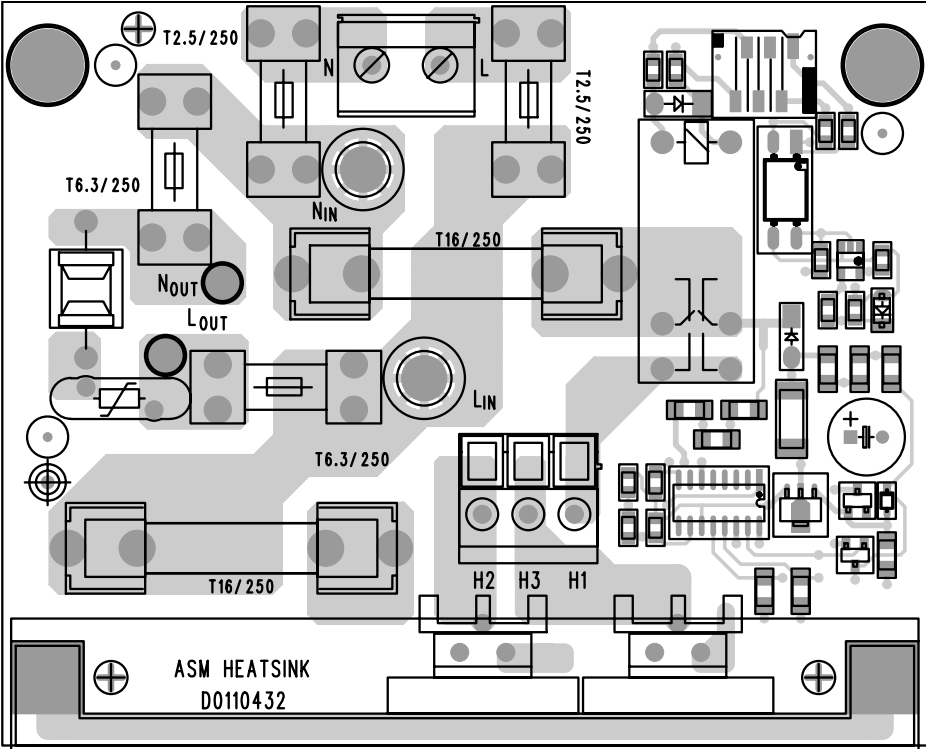

8.27 Power board (power supply unit 4008)

