

CONCORD
CONNECTING TOGETHER

DVR Manual

Index

Title	Page	Title	Page	Title	Page
Safety Precautions	5	4.3 Network Configuration	15	5.5.1 Information	29
Chapter 1 Product Overview		4.4 Set Date & Time	16	5.5.2 Channel Information	30
1.1 What's in the box?	6	4.5 Camera Configuration	17	5.5.3 Record Info	31
1.2 What's what on the box?	7	4.6 Configure Storage	18	5.5.4 Network State	32
Chapter 2 DVR Installation & Connection		4.7 Configure Resolution	19	System Setup	33
2.1 Connection Diagram	8	4.8 Configure Mobile App	20	Chapter 6 Channel Setup	
2.2 Power Supply Connection	9	4.9 Finish Set-Up	21	6.1 General Controls	34
Chapter 3 Common Operations		Chapter 5 Live View		6.2 Channel Menu	35
3.1 Using the Supplied Mouse	10	5.0 Live View	22	6.2.1 Channel Live Menu	36
3.2 Using the Virtual Keyboard	11	5.1 Live View Iconography	24	6.2.2 Channel Live Display Setup Menu	37
3.3 Start Menu	12	5.2 Camera Quick Toolbar	25	6.3 Channel Image Control Menu	38
Chapter 4 DVR Setup		5.3 Live View Task Bar	27	6.4 Channel Pan-Tilt-Zoom (PTZ) Menu	39
4.1 Before You Begin	13	5.4 Manual Record	28	6.5 Video Capture Menus	40
4.2 Create a Password	14	5.5 System Information	29	6.6 Video Cover Menu	41

Index

Title	Page	Title	Page	Title	Page
6.7 Motion Menu	42	7.3.1 Record Schedule	59	9.1.2 General – Port Configuration	86
6.7.1 Motion Detection Set-up	43	7.4 Capture Setup	60	9.2 DDNS	87
6.8 PIR Set-up	44	7.5 Motion & PIR Alarm Setup	61	9.3 Email	88
6.9 Intelligent Set-up	46	7.6 Exception Setup	64	9.3.1 Email Schedule	92
Chapter 7 Record Setup	47	Chapter 8 Playback & Search	65	9.4 FTP	93
7.1 Stream Type	48	8.1 Using Search Function	65	9.4.1 FTP Schedule	94
7.2 Encode	49	8.2 Search & Play Video in the General Menu	68	Chapter 10 Device Setup	
7.2.1 Encode Resolution	50	8.2.1 Video Clip Backup	69	10.1 Disk	95
7.2.2 Encode FPS	51	8.2.2 Event Search, Playback & Backup	72	10.2 S.M.A.R.T	96
7.2.3 Video Encode Type	52	8.2.3 Sub-periods Playback	76	10.3 Cloud	97
7.2.4 Encode Bitrate Control	53	8.3 Tag Search and View	78	Chapter 11 System	
7.2.5 Encode Bitrate Mode	55	Chapter 9 Network Setup		11.1 System General Menu	101
7.2.6 I Frame Interval	57	9.1 General	84	11.1.1 General	101
7.3 Record	58	9.1.1 General - PPPoE	85	11.1.2 Date and Time	102

Index

Title	Page	Title	Page
11.1.3 Output Configuration	103	11.5.3 Record Info	119
11.2 Multi-User	106	11.5.4 Network State	119
11.2.1 Changing Admin Password	107		
11.2.2 Add New Users	108		
11.2.3 New Users	109		
11.3 Maintenance	110		
11.3.1 Log	111		
11.3.2 Load Default	112		
11.3.3 System Upgrade	113		
11.3.4 Parameter Management	114		
11.3.5 Auto Reboot	115		
11.4 IP Camera Maintain	116		
11.5 IP Information	117		
11.5.1 Channel Info	118		

Safety Precautions

Please carefully read the following safety precautions so as to avoid personal injuries and prevent the equipment and other connection devices from being damaged.

1. Power supply

Never operate the equipment with any power supply other than the one supplied in the box.

2. Never push objects of any kind through the openings of the DVR

Never push objects of any kind through any openings of the DVR to avoid electric shock or damage to your DVR.

3. Do not place the DVR in a dusty environment

Dust could affect the connections and damage the electronics.

4. Do not place the DVR in a wet or humid environment

Do not position the DVR in a location that is likely to get wet or humid such as outdoors or in a basement. If the DVR comes into contact with water, unplug the power cable immediately and contact your local dealer.

5. Keep the surface of the equipment clean and dry

Use a soft slightly damp cloth to clean the outer case of DVR and make sure it is dried straight away (do not use liquid aerosol cleaners).

6. Do not operate if you notice any unusual problems

If you notice any strange smells, sounds or smoke coming from your DVR, unplug the power cable immediately and contact an authorised dealer or service centre.

7. Do not try to remove the upper cover

Warning: Do not remove the cover of your DVR to avoid electric shock or damage to the electronics.

8. Handle with care

If your DVR does not work normally after dropping it or being hit by a hard object, disconnect the power immediately and contact an authorised dealer or service centre.

9. Position the equipment in a place with good ventilation

The DVR system includes a HDD, which can produce a significant amount of heat during normal operation. As a result, do not block the ventilation openings (on the top, bottom, both sides and the reverse side) for cooling the system during operation. Make sure your DVR is kept in a well ventilated area and that the cables are kept tidy and do not obstruct air flow.

10. The included power supply can only be used for one DVR system, do not connect more equipment to the power supply, it will not have enough power to operate correctly.

11. Do not place objects containing water, such as a flower vase, on or near the equipment.

Chapter 1 Product Overview

1.1 What's in the box?

Congratulations on your new Concord Professional Surveillance System. Inside the box you will find everything you need to connect your DVR and cameras to your TV or monitor.



DVR Recorder Unit



Cameras (4, 6 or 8)



HDMI cable



Ethernet Cable



USB Mouse



Mounting accessories



Camera cable (4, 6 or 8)



12V Power Supply with Adapters (see below)

Check below for the power supply that comes with your model.



CDK4242P-V2 & CDK8242P-V2



CDK8845P-V2 & CDK8848P-V2



CDK8262P-V2 & CDK8868P-V2

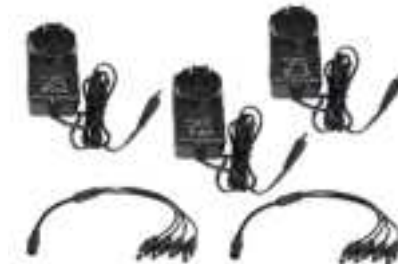

CDK8282P-V2

Chapter 1 Product Overview

1.2 What's what on the box?

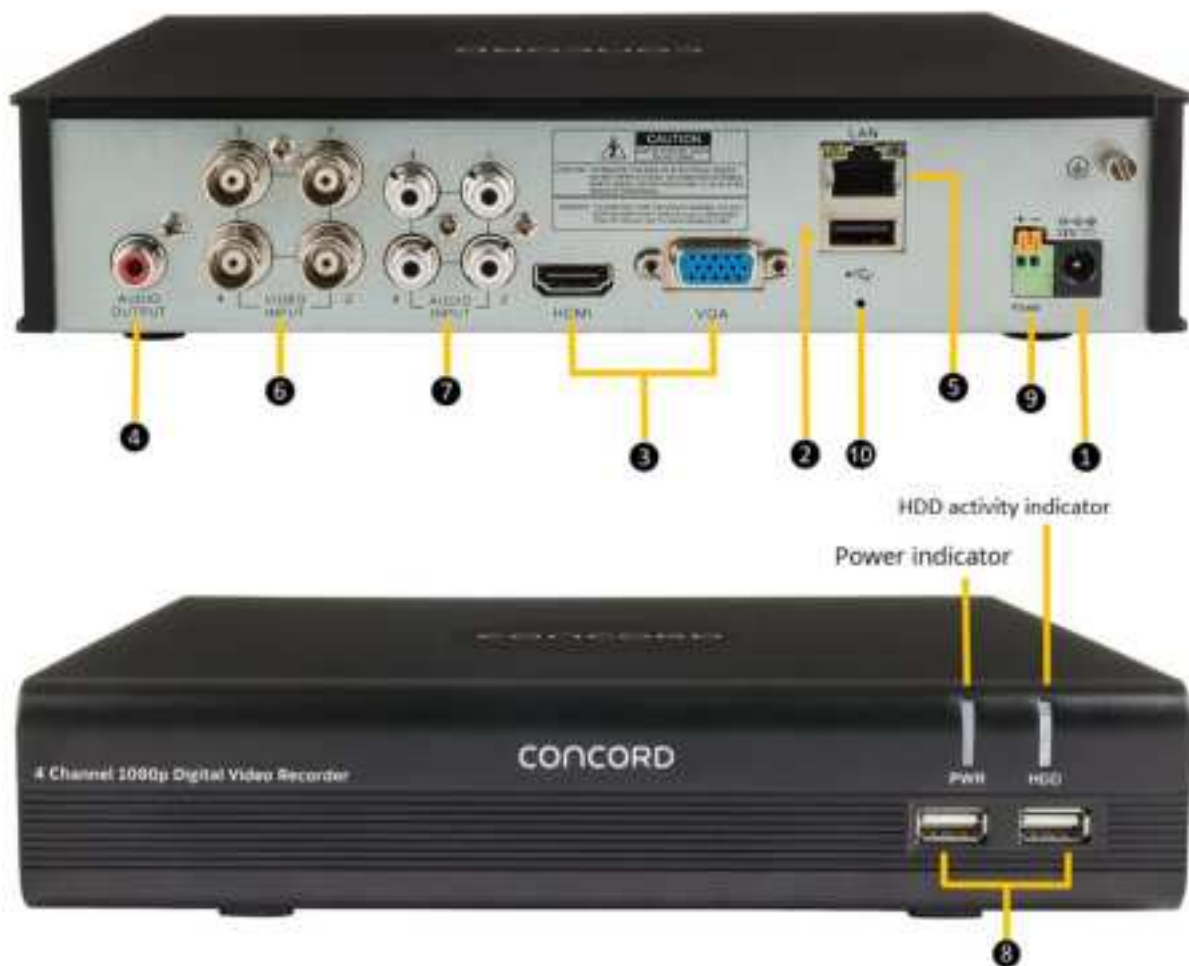

1	Power Input	Connect to the supplied mains power adaptor
2	USB Port	Connect the supplied mouse or external USB Hard Drive.
3	Connect Monitor	Connect to your TV or monitor, using either supplied HDMI or, if not available use the VGA Output (cable not supplied).
4	Audio Output	Connect to an amplifier or active speakers. RCA connection.
5	LAN Port	Connect to your network router using supplied RJ45 Ethernet cable.
6	Camera Ports	BNC camera video inputs.
7	Audio Input	Microphone input. RCA Connection.
8	USB Ports	Connect the supplied mouse or external USB Hard Drive.
9	RS485/PTZ	Connect to third-party cameras that have a Pan-Tilt-Zoom function
10	Reset Button	Manual reset button for the unit.

Chapter 2 DVR Installation & Connection

2.1 Connection Diagram

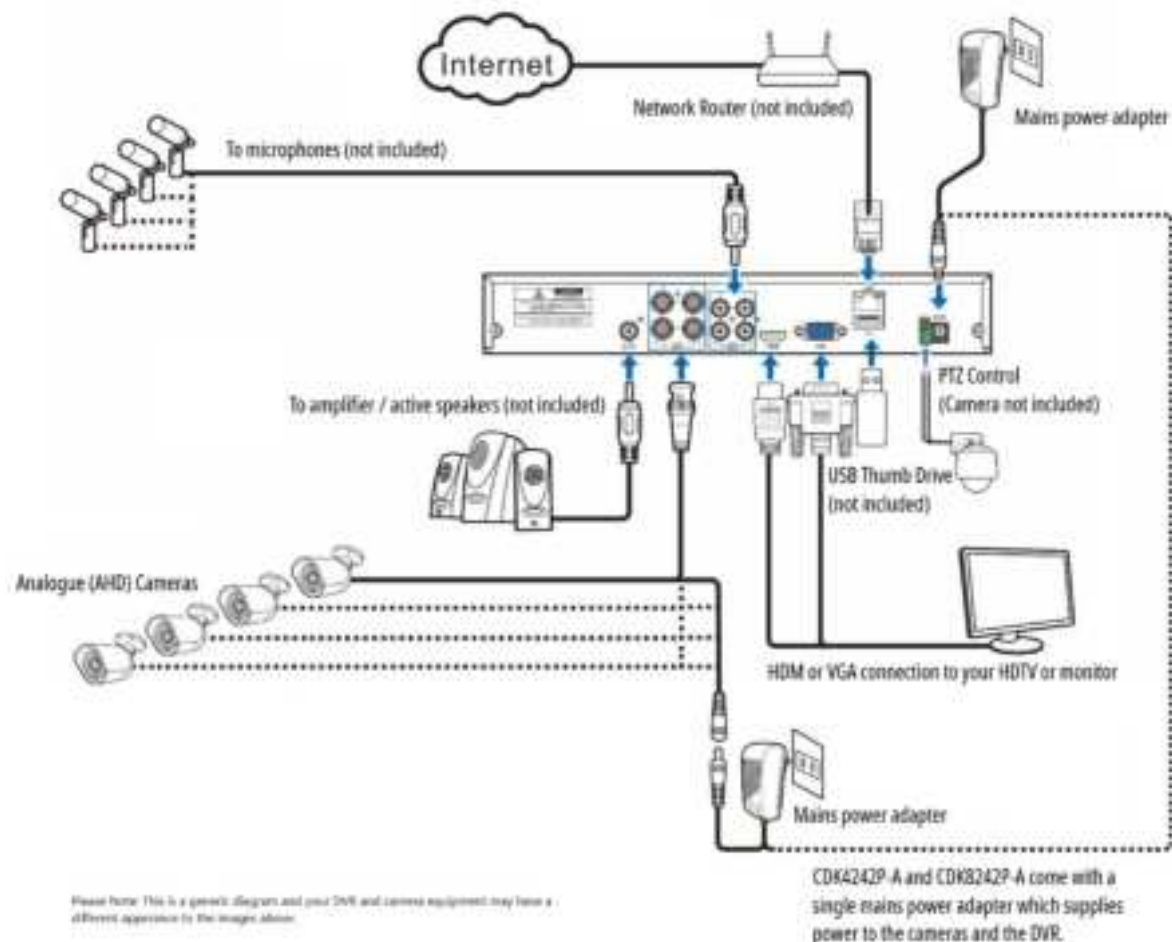

Note:

The above diagram is for reference purposes only, and uses a 4 channel DVR for the example. Your connections and setup may differ from this description. **Any DVR with more than four cameras will come with an extra power supply.**

Chapter 2 DVR Installation & Connection

2.2 Power Supply Connection

A mains power adaptor is included in the kit. Plug the adaptor into an available mains power outlet and the other end into the power socket on the back of the DVR.

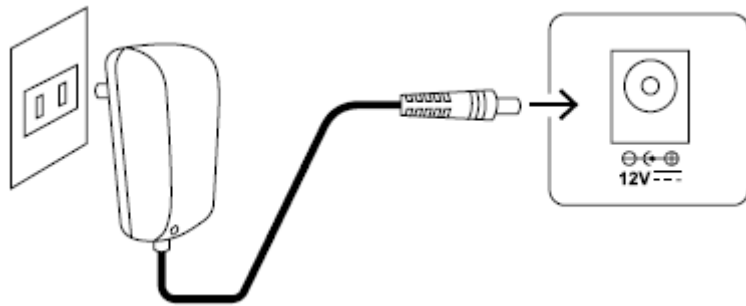

Chapter 3 DVR Common Operations

3.1 Using the Supplied Mouse

A USB Mouse is supplied to navigate the on-screen menus. Plug the mouse into an available USB port on the front or back of the DVR.

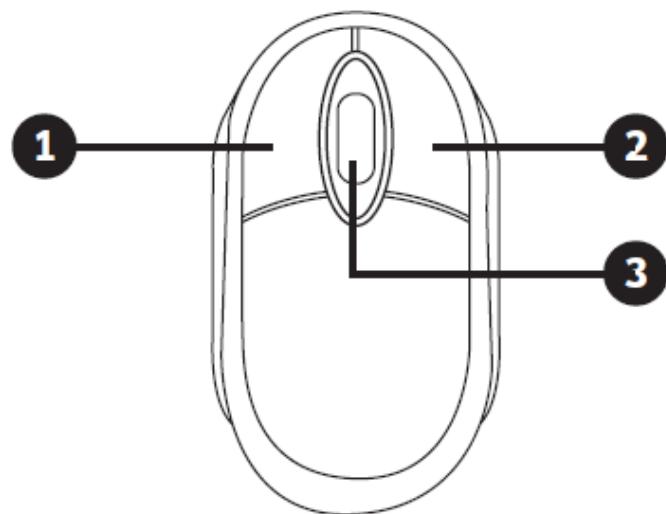

1. Left Button:

Click to select menu options.

During live viewing in split-screen view, double-click on a channel to view it in full-screen. Double-click the channel again to return to split-screen viewing.

Click on a channel on Live Viewing screen to open Camera Quick Toolbar.

Click and hold to drag sliders and scales on menu mode

2. Right Button:

Click once to open the Taskbar on the Live Viewing screen. In menus, click to go back / close menus.

3. Scroll Wheel:

In menus, scroll to move up / down through the menu content.

While hovering over the volume control wheel, scroll to turn system volume up / down.

Chapter 3 DVR Common Operations

3.2 Using the Virtual Keyboard

A virtual keyboard will automatically appear on the screen when you need to enter data. Use the mouse to operate this keyboard.

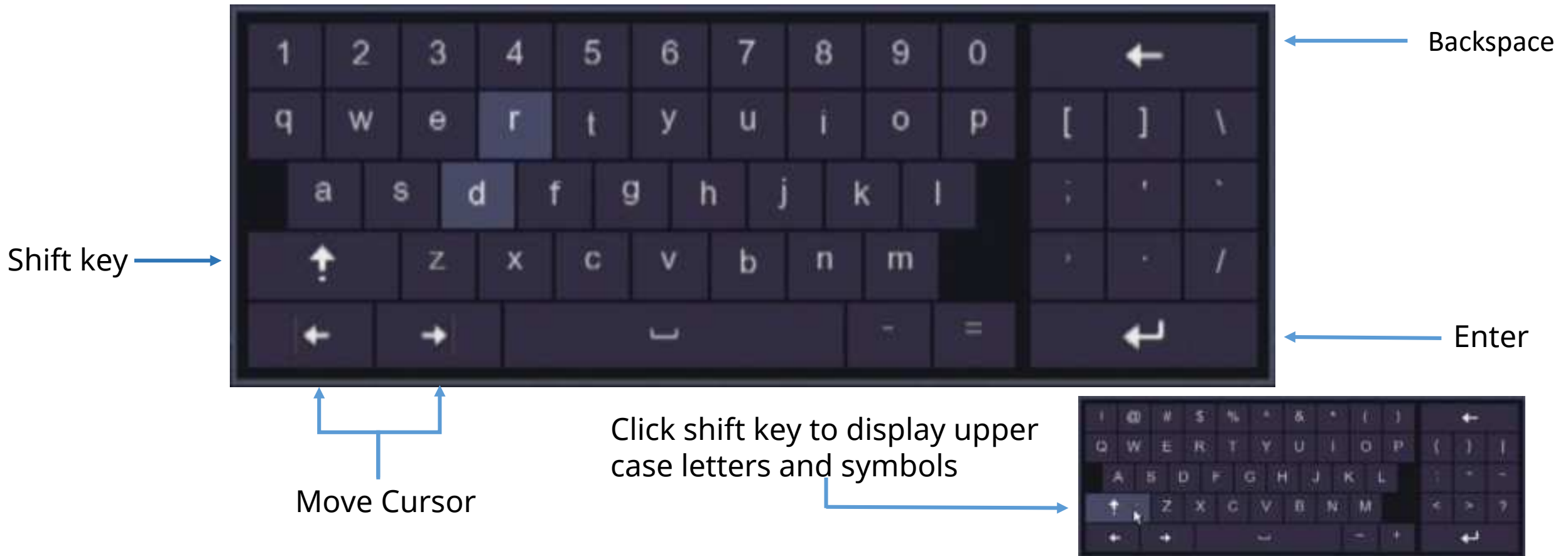

Chapter 3 DVR Common Operations

3.3 Start Menu

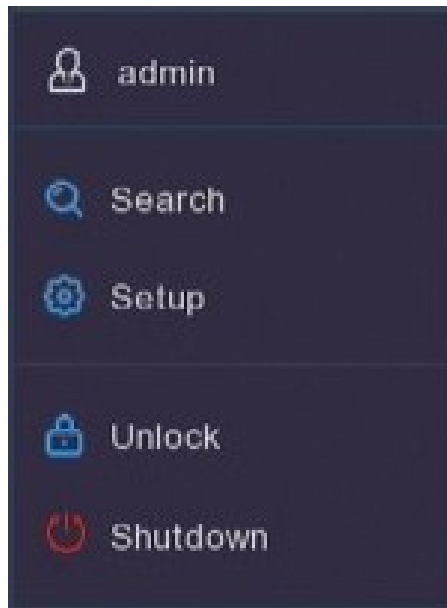

In this menu you can switch users, search videos, set up your DVR/NVR, manually lock the screen and shutdown, reboot or logout of the system.

Whenever you want to make changes to the way your system operates you will need to use your password to unlock the screen. You will only need to enter this once in a session, however if you are inactive for five minutes you will need to re-enter the password.

To switch on and off features and to make adjustments to how they work click on the Setup  icon, this icon appears throughout the menus indicating where to click you can make changes.

Chapter 4 DVR Setup

4.1 Before You Begin

Before you begin setting up your DVR make sure:

1. You complete the hardware installation.
2. Your DVR/NVR is connected to a display.
3. The DVR/NVR is connected to the Internet.
4. Cameras are connected to the DVR/NVR and powered up.

ATTENTION

This initial Setup Guide is intended to provide a minimal effort guide to setting up a basic operational DVR system with default settings. More in-depth instructions for fine tuning your system can be found further in this manual.

Chapter 4 DVR Setup

4.2 Create a Password

The screenshot shows a dark-themed web interface for DVR setup. It includes the following fields and controls:

- Language:** A dropdown menu currently set to "ENGLISH".
- Device ID:** A text input field containing "000000" with a "(000000)" label to its right.
- New Admin Name:** A text input field containing "admin".
- Password Strength:** A progress indicator consisting of three bars, with the first two filled.
- New Admin Password:** A password input field with a "Show Password" checkbox to its right.
- Confirm Password:** A password input field with a "Show Password" checkbox to its right.
- Unlock Pattern Enable:** A dropdown menu currently set to "No".
- Apply:** A button located at the bottom center of the form.

Language	English is default
Device ID	If you have more than one DVR it is useful to give each device a unique ID
Admin Name	Choose a login name, such as John, or Mary, etc., or any other name that you will easily remember. Generally, 'admin' is a common login name to use here
Admin Password	The password needs to be a minimum of six characters and can contain a mixture of numbers and letters. Use a password that you are familiar with, but is not easily known to others.
Apply	Click Apply to save your settings

ATTENTION

Be sure to write down your login credentials in a secure place. If you forget your password you will not be able to access the DVR, and you will need to contact Concord customer support to reset the DVR password if you have not set up e-mail notifications.

Chapter 4 DVR Setup

4.3 Network Configuration

After setting up your password the next step is the Network Configuration Screen.

There isn't much you should need to do here but ensure the **"DHCP"** checkbox is ticked.

The DVR/NVR automatically configures all other network parameters.

Click the 'Next' button.

ATTENTION

If you need to change the network settings, refer to the network section in this manual.



The screenshot shows the 'Network' configuration screen in a 'Wizard' window. The 'Local Connection' section has the 'DHCP' checkbox checked and highlighted with a red box. Below it, the IP Address, Subnet Mask, and Gateway are all set to 192.168.1.1. The DNS section shows DNS1 and DNS2 both set to 192.168.1.1. The Port section contains a table with four rows of port configurations.

	Service	Protocol	Internal Port	External Port	UPnP Status	UPnP
1	Web	TCP	8080	8080	Inactive	<input type="checkbox"/>
2	Client	TCP	8000	8000	Inactive	<input type="checkbox"/>
3	RTSP	TCP	5554	5554	Inactive	<input type="checkbox"/>
4	HTTP	TCP	4443	4443	Inactive	<input type="checkbox"/>

Below the table, there are sections for 'PPPoE' (with 'Enable PPPoE' checked), 'User' and 'Password' fields (with a 'Show Password' checkbox), and '3G' (with 'Enable 3G' checked and an 'APN' field containing '3gnet'). 'Next' and 'Cancel' buttons are at the bottom right.

Chapter 4 DVR Setup

4.4 Set Date & Time

This menu will set the system date and time, click the tabs to make adjustments.

Date and Time: Set date, time, formats and time zone.

NTP: You can also choose NTP (network time protocol) to automatically set the time using the network.

DST: Set when DST (daylight saving time) begins and ends so the system will automatically adjust itself.

Click the **Next** button at the bottom of the screen to confirm changes.

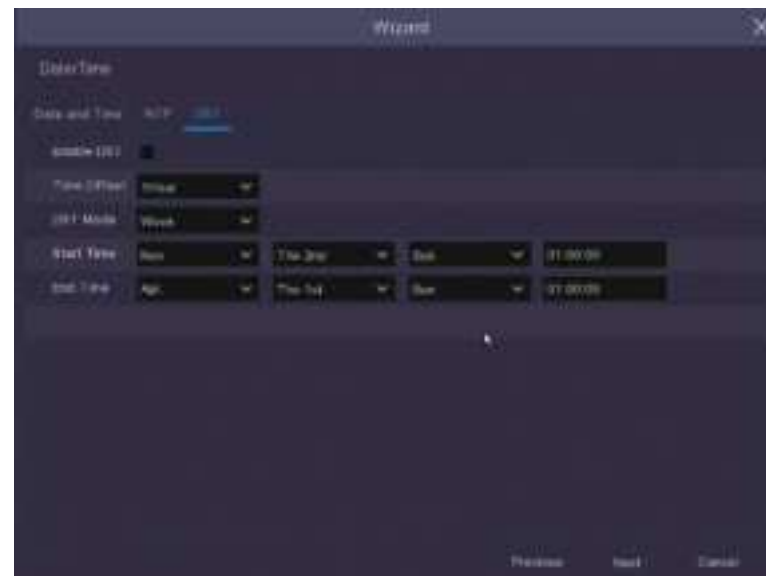
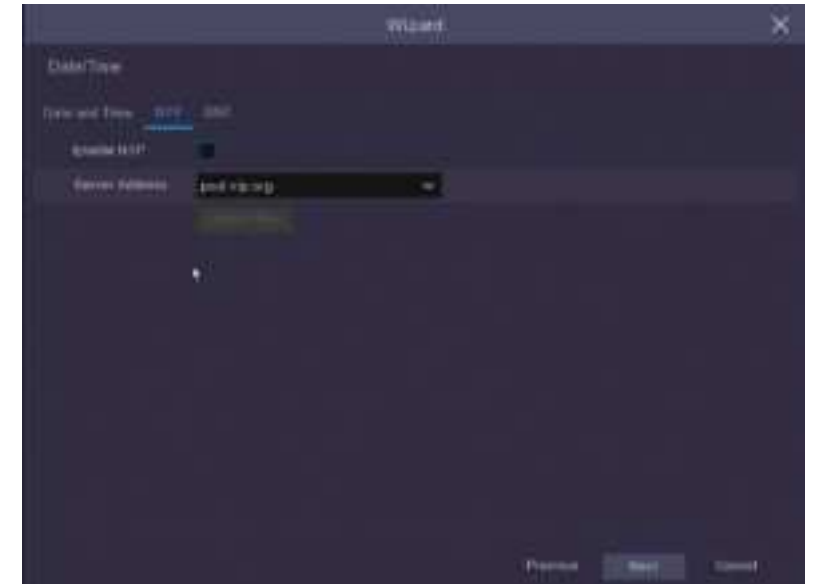
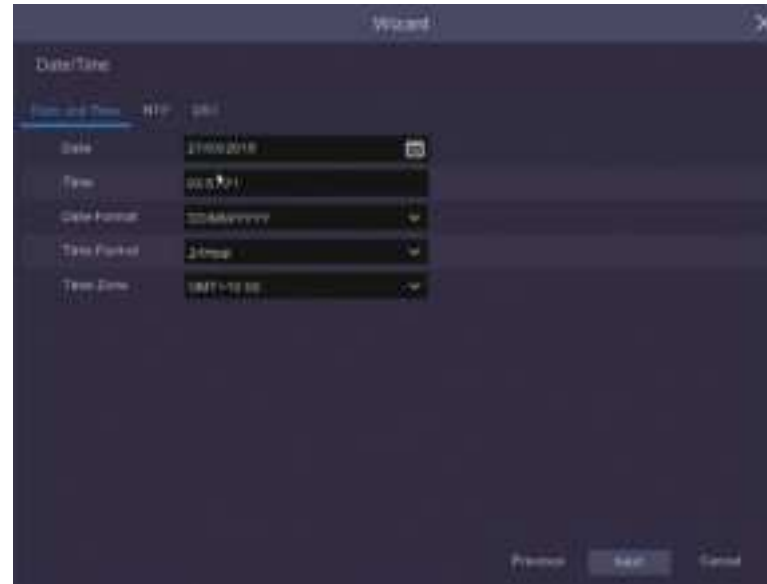

Chapter 4 DVR Setup

4.5 Camera Configuration

This menu is for use when adding IP cameras through a router, it will not be necessary for most users so simply click **Next.**

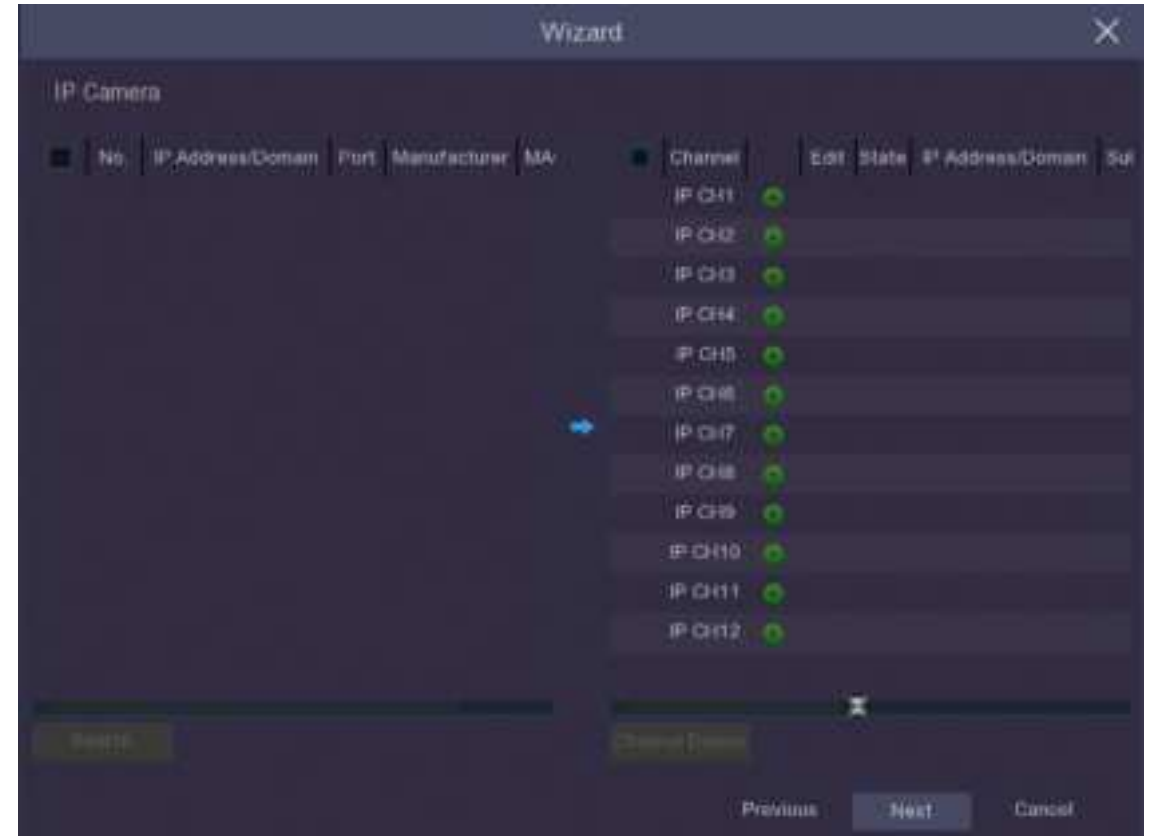

Chapter 4 DVR Setup

4.6 Configure Storage

It is recommended to **Format** the **HDD** before first use – this will erase all stored data on the HDD.

Auto Overwrite makes new data overwrite the old data as the HDD fills up.

If you disable the **Auto Overwrite** feature, no new footage will be captured once the HDD is full.

You can also choose to automatically overwrite the data at different time periods from once a day to every ninety days. This ensures you keep your recordings for the period of time you think is most suitable.

When you have finished making your selection click **Next** to continue.

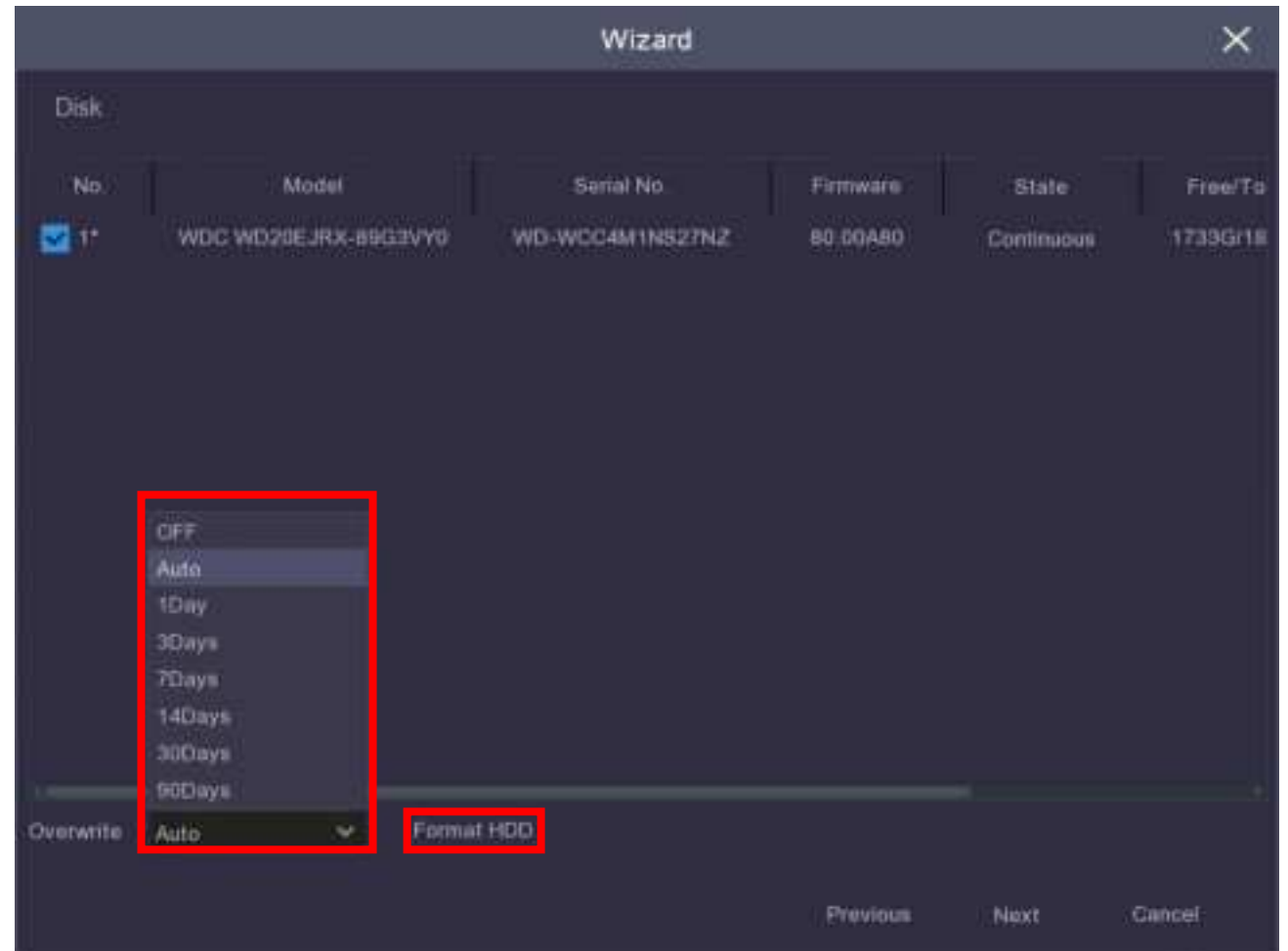

Chapter 4 DVR Setup

4.7 Configure Resolution

Output Resolution drop down menu sets the image resolution displayed on the monitor or TV screen. This sets automatically when using the HDMI cable but can be adjusted manually if using the VGA option or if you intend to display a lot of channels on your screen.

Once you have completed selecting the output resolution in this window click **Apply** and a window will pop up asking you to confirm that you want to change the Output Resolution, confirm this and when the window closes click **Next** and you will be taken to the **Mobile** screen where you can begin setting up the **Mobile App** on your phone or tablet.

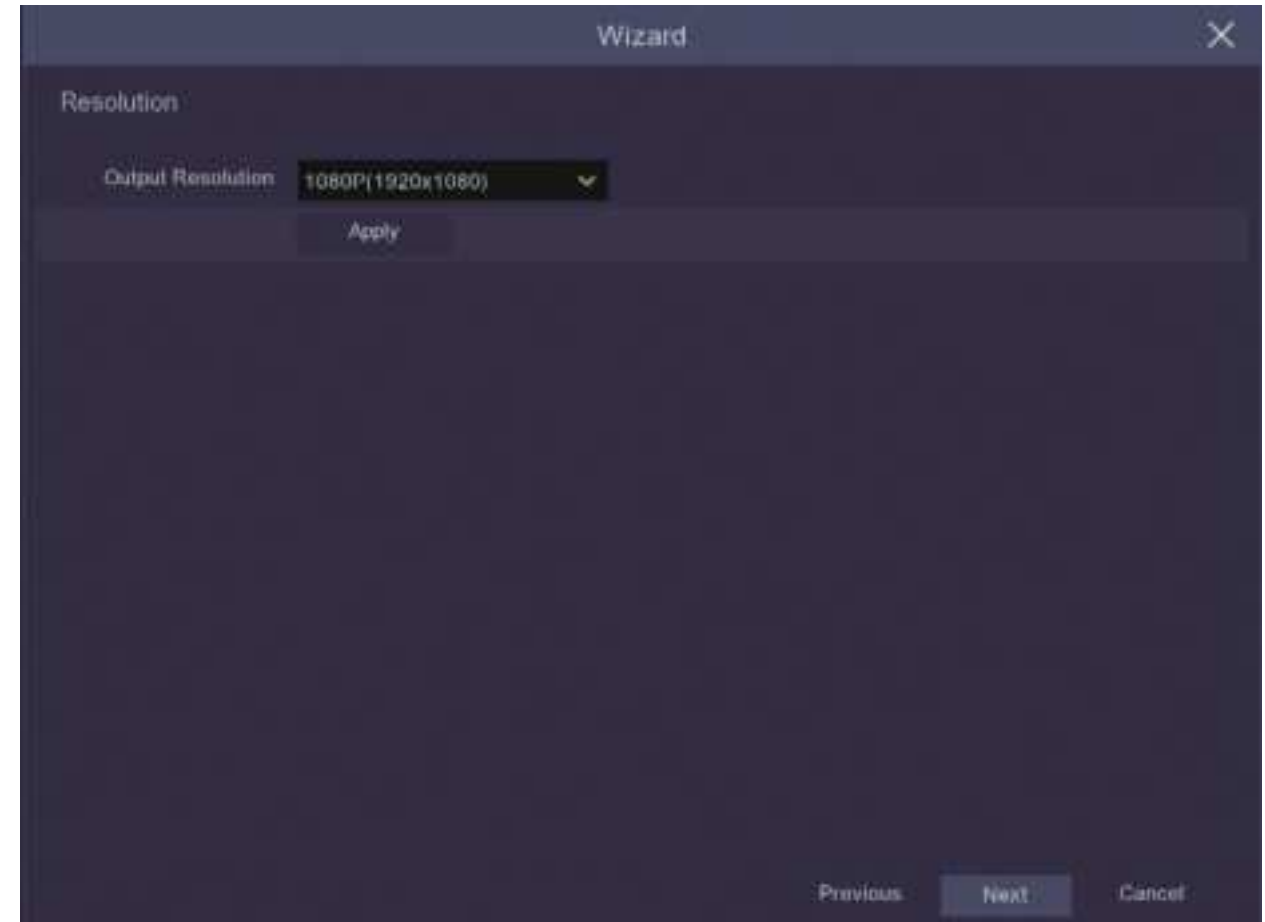

Chapter 4 DVR Setup

4.8 Configure Mobile App

1. Download the **Concord Security App** Available on **Google Play™** and **Apple App Store™**.



2. When you first open the Concord Security App, you will see a blank screen, on the top right hand click on the '+' symbol.

3. The smart phone camera will be activated, position your phone in front of the DVR screen over the QR code.

4. Once the Concord App has successfully scanned the QR code it will automatically populate the network configuration for your DVR into the smart phone App.

5. You will need to enter the user name and password exactly as it was set up in the DVR and remember that these fields are case sensitive.

6. Once you have successfully logged in, you will be able to view your DVR from anywhere using your smart phone.



Chapter 4 DVR Setup

4.9 Finish Set-Up

Review the settings and if you are happy with everything simply click the “Finish” button to save & exit the Wizard.



Chapter 5 Live View

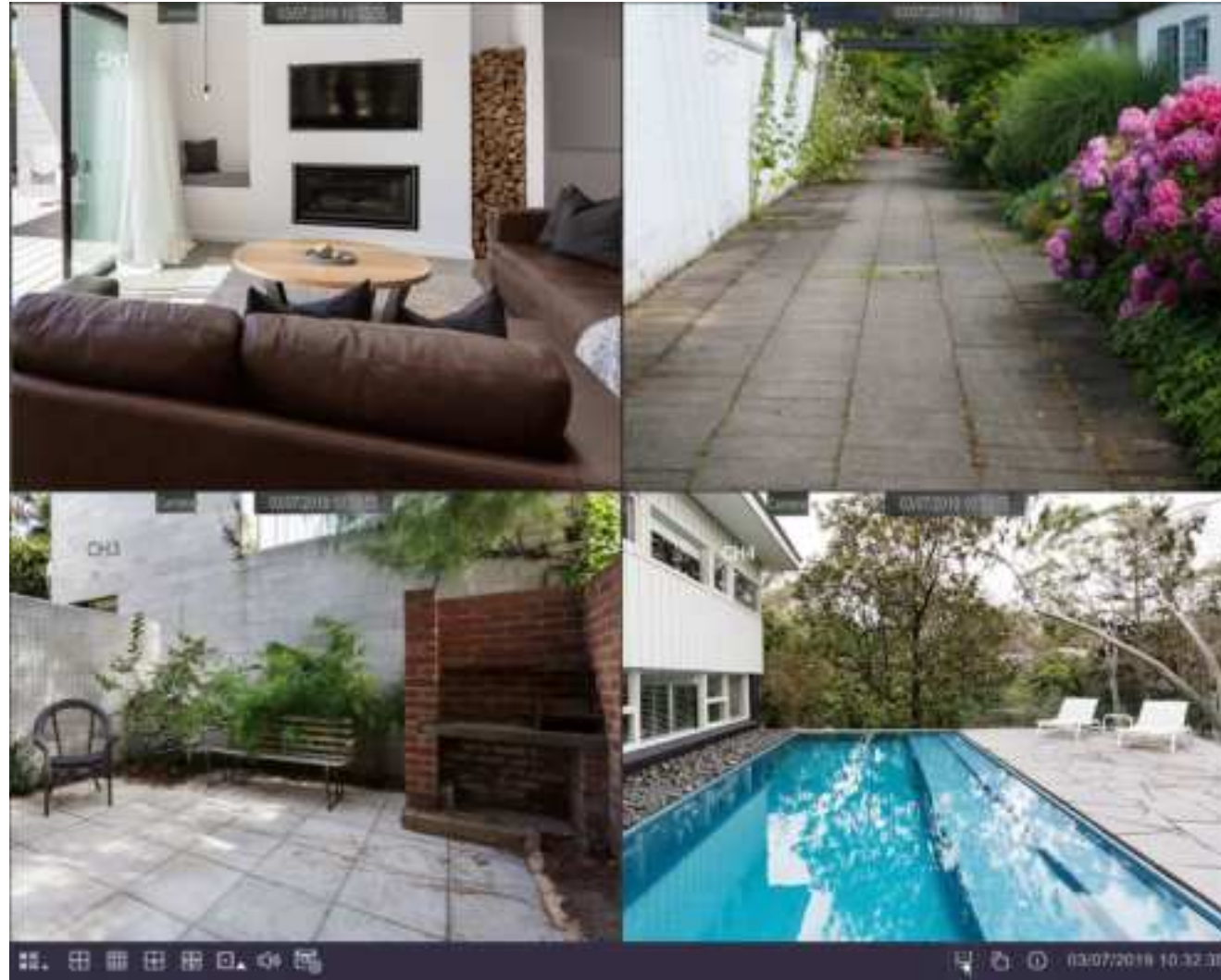





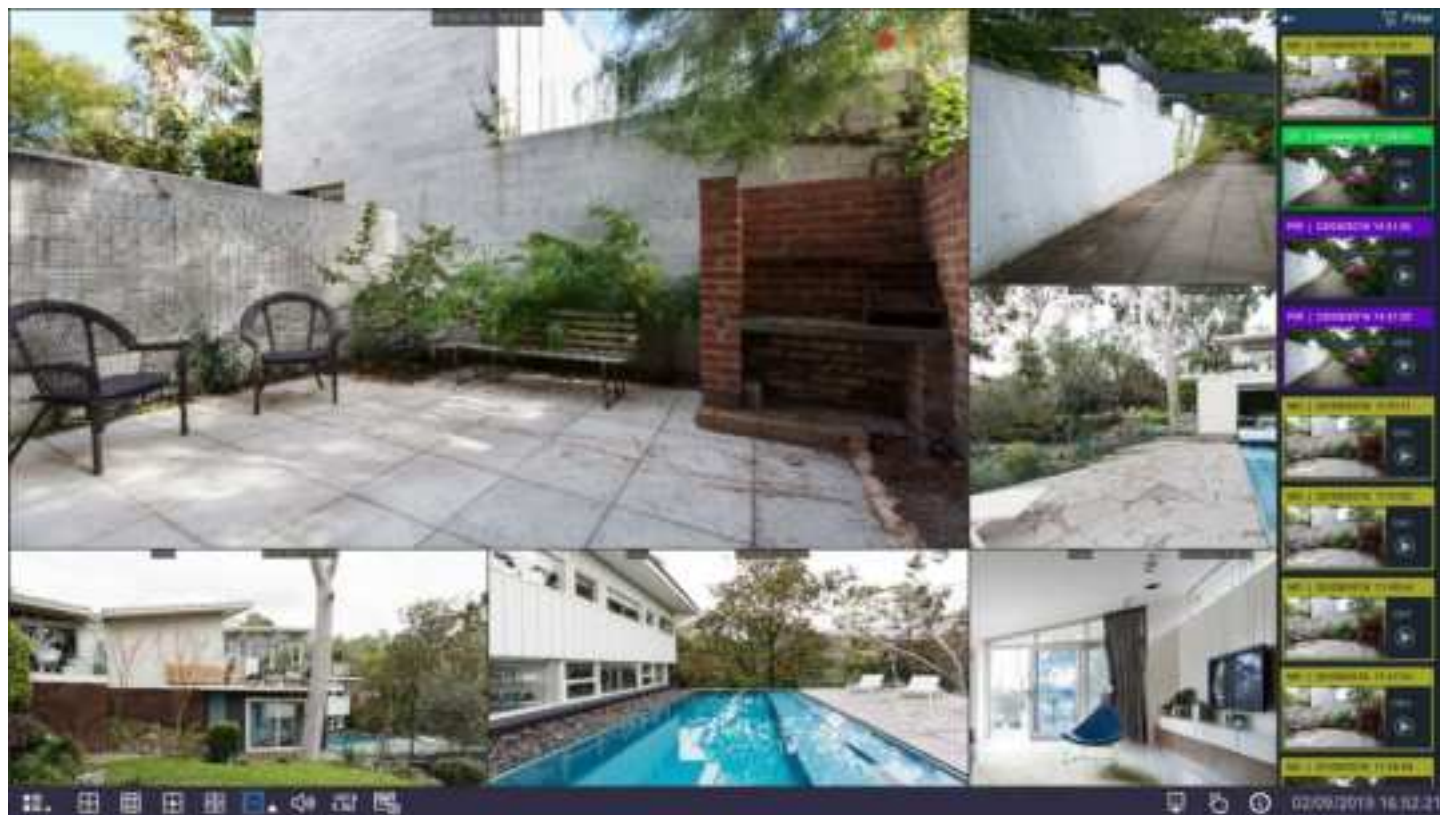



Chapter 5 Live View

5.0 Live View



The Live View screen is the default display you will see when the DVR is on. You will be able to see each of the connected cameras and you can select the format in which they are displayed with either single images, scrolling single images or multiple images on the one screen.

If there have been recent recordings on any of the channels, these will show up on a scroll bar on the right hand side of the screen. This will show the channel name, a still image of the channel, the time of the activity and will be colour coded to the type of recording that has been made. You can also click on the play button  to view the recording. You can choose to pin  this menu otherwise it will collapse after a few minutes until the next activity is recorded.

- | | |
|--|---|
|  Continuous recording |  Intelligent |
|  Motion detection |  Alarm (Combined Motion detection and PIR) |
|  IO (Smart) |  Manual |
|  PIR detection | |

Chapter 5 Live View

5.1 Live View Iconography

Channel Status Icon

 DVR is recording on this channel.

 A PIR detection has been made on this channel.

 Camera has detected motion.

 Alarm has been triggered.

 Error on HDD.

 HDD unformatted.

 HDD is full.

 HDD is set to read only.

A-CH#: An AHD protocol camera is connected to this channel.

IP-CH#: An IP camera is connected to this channel.

Check the status, date and time of your DVR with icons and text on the Live View screen

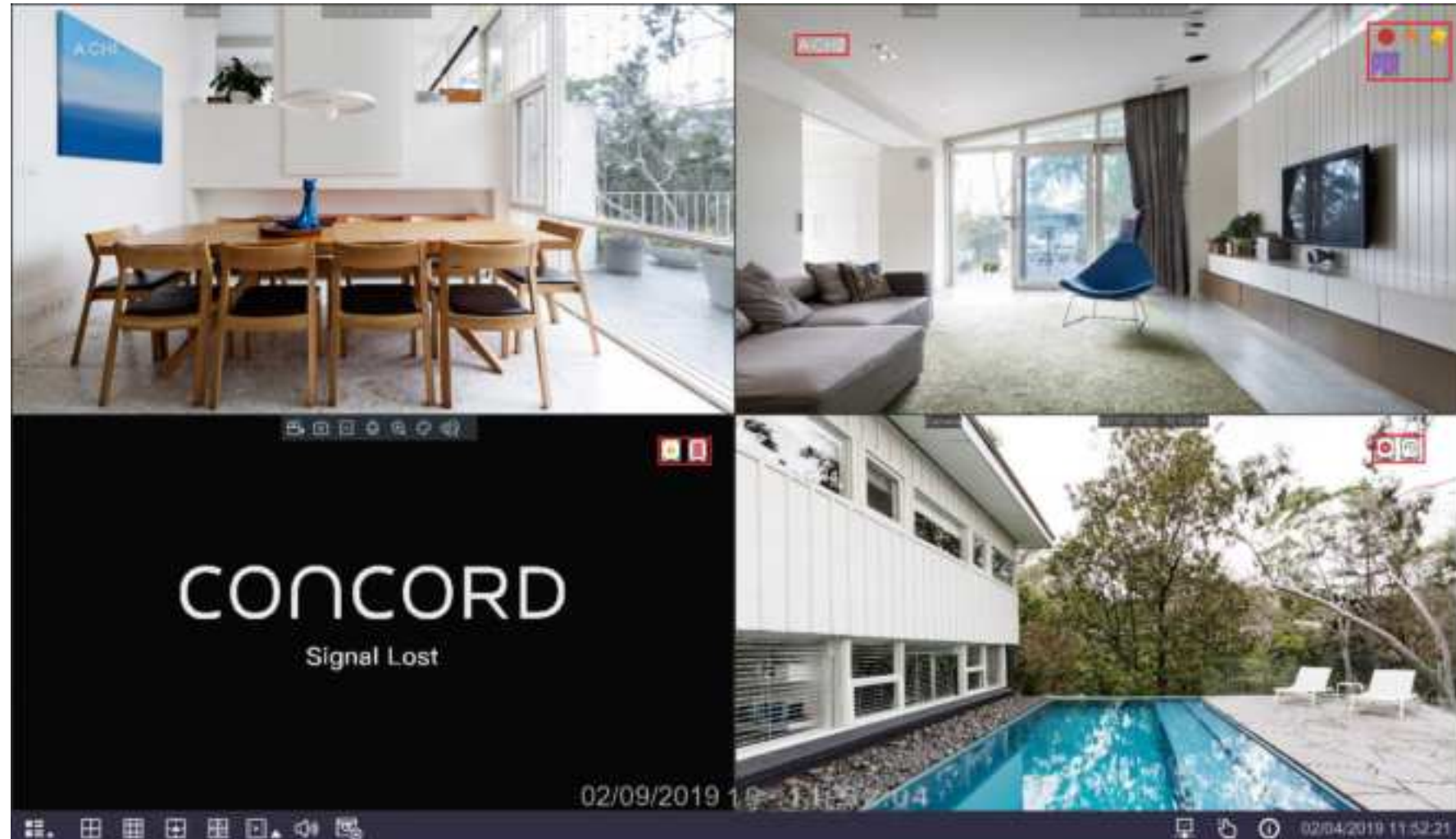

Chapter 5 Live View

5.2 Camera Quick Toolbar

 Manually record this channel. Click once to start and again to stop.

 Manually capture an image. Must be enabled in Capture Menu.

 Play back the last five minutes of recorded footage.

 Open PTZ control window.

 Zoom in on the image. (See following page for instructions.)

 Adjust the colour settings for this channel.

 Add a manual tag to this channel.

If you see **Signal Lost** on a channel it means the camera has stopped communicating with the DVR, this is usually because the it has come unplugged.

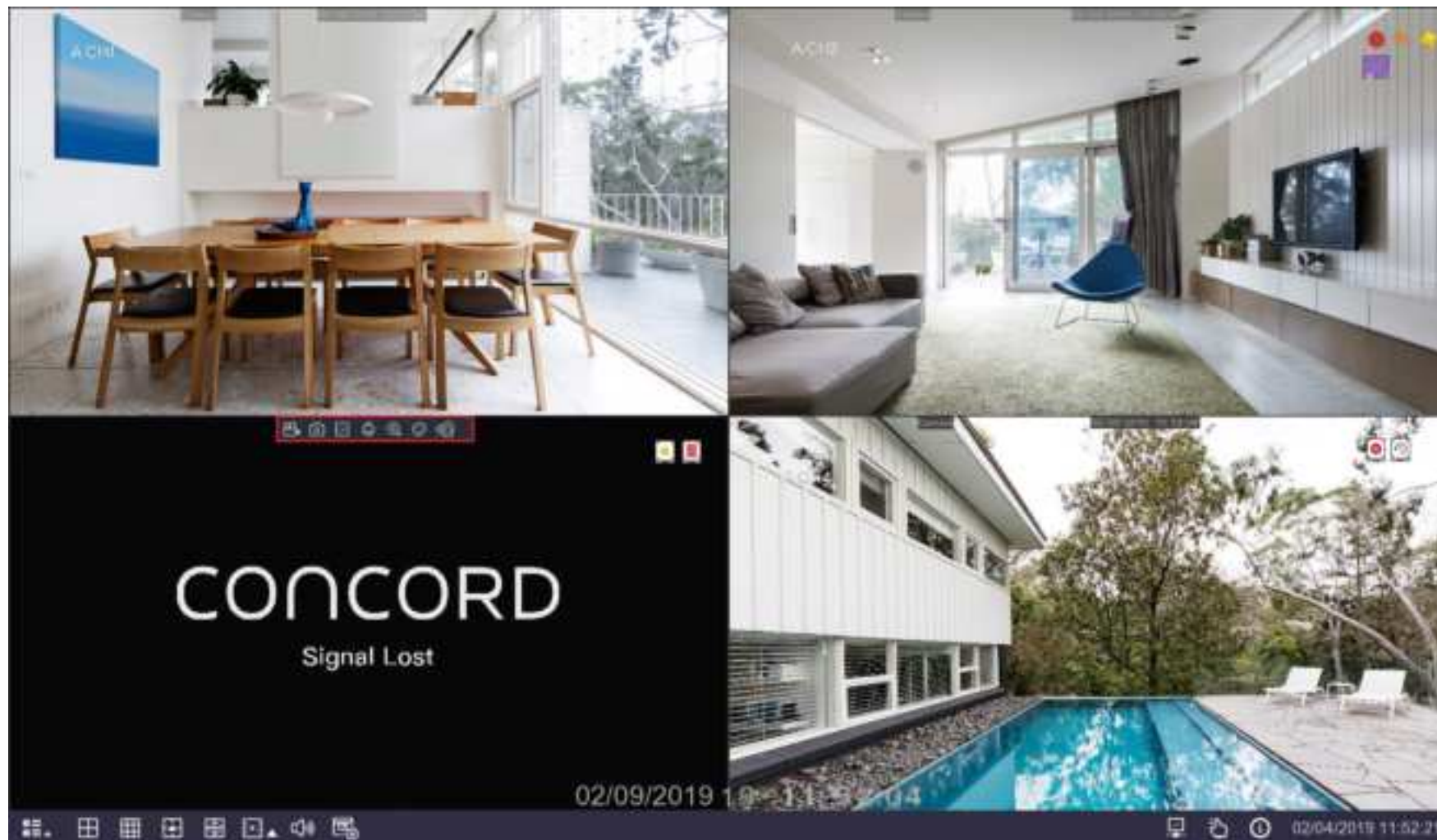

Chapter 5 Live View

5.2 Camera Quick Toolbar







When you click on the  zoom icon channel that you have selected will expand to full screen and a small screen will appear in the bottom right hand corner showing the full channel image. To zoom in and out use the mouse scroll wheel, a smaller rectangle will appear in the full channel image showing the area you are zooming in on, you can move this area by left-clicking on the rectangle area and moving it around the image.



Chapter 5 Live View

5.3 Live View Task Bar

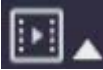
Left Hand Side

-  Open the Start Menu to access Shutdown, Unlock, Setup, Search and Admin.
-  Four channel layout view.
-  Select alternate channel layout views.
-  Scrolls between full screen views of each channel.
-  Play back latest recordings from each channel. You can select last 5s, 10s, 30s, 1min, or 5min.
-  Adjust audio volume.
-  Switch view modes based on bitrate, available modes are Real Time Balanced and Smooth View. This does not affect recording quality.

Right Hand Side

-  Network disconnected.
-  Network connected.
-  Manual record.
-  System information.

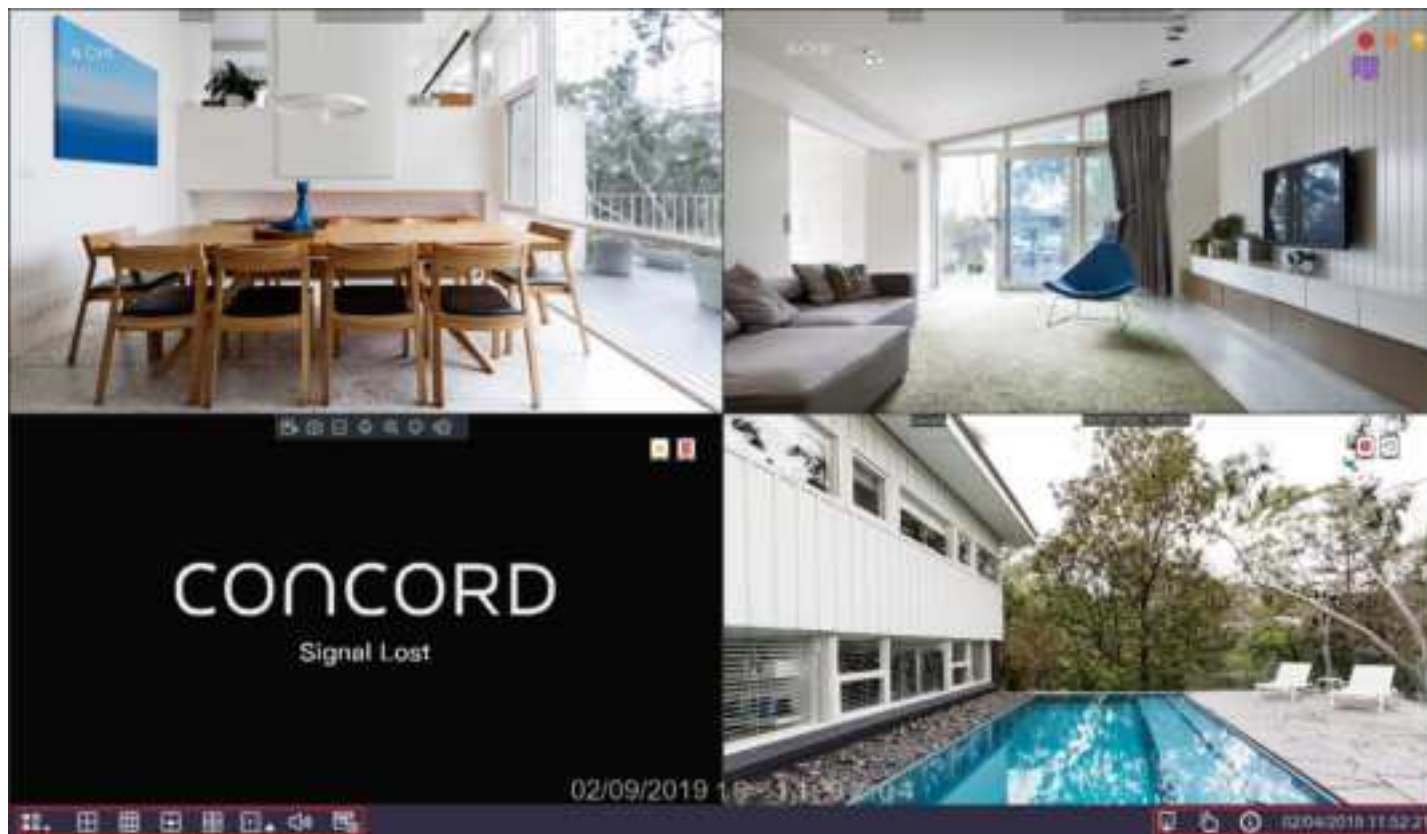

Chapter 5 Live View

5.4 Manual Record

When you click on the Manual Record icon  in the taskbar a menu will pop up that allows you to immediately begin recording on any of the channels by clicking on the slider next to the channel you wish to record.

This is a handy tool if you want to quickly change to constant recording or if you want to test the channel.

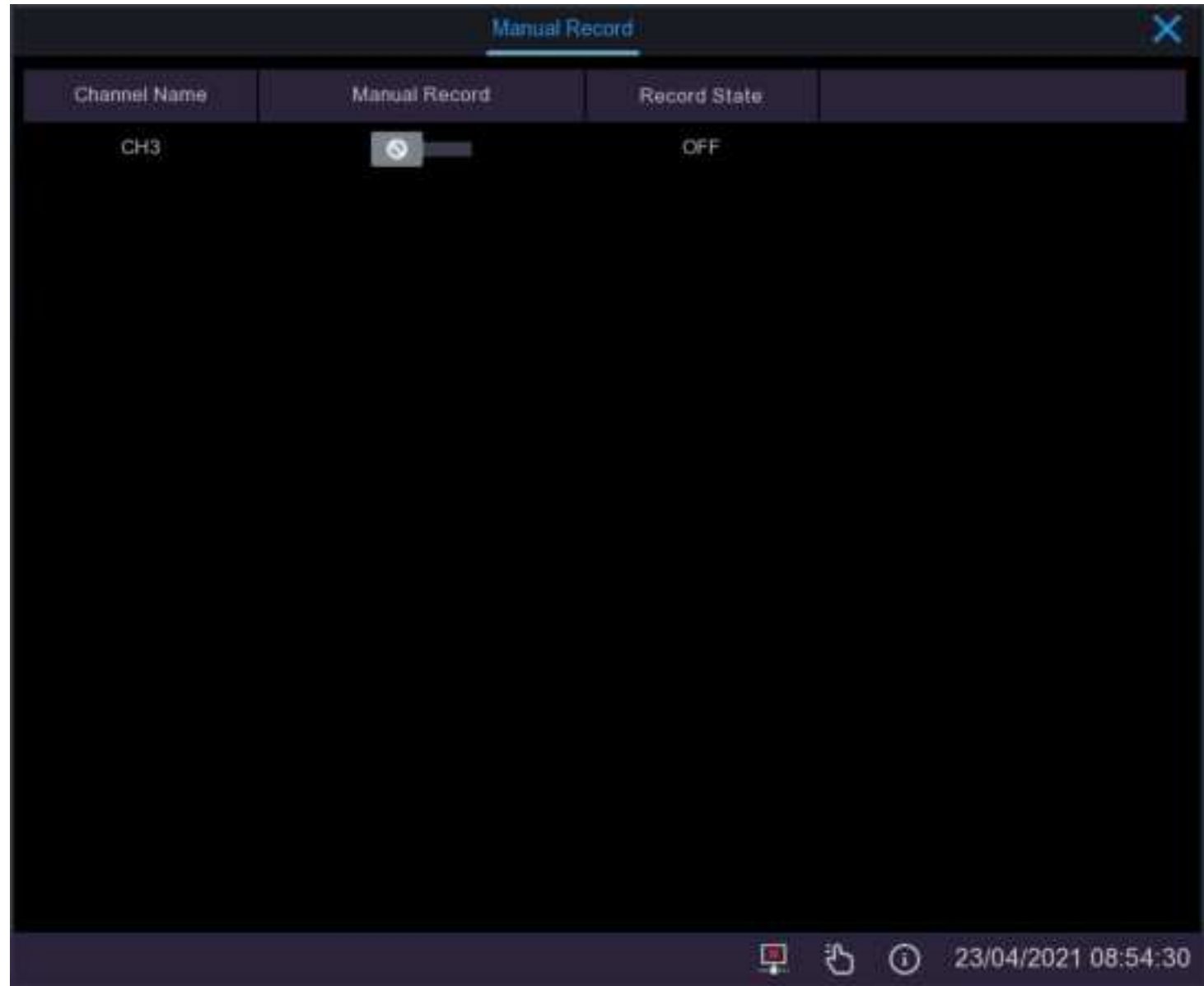

Chapter 5 Live View

5.5 System Information

5.5.1 Information

When you click on the Information icon  in the taskbar a window will pop up with a summary of your system settings and the versions you are running.

This is a useful resource if you are upgrading cameras or if you have forgotten your password and need the MAC address to get us to reset your password.

This window also includes a copy of your machine's unique QR code that you can use to add your system to the phone app.

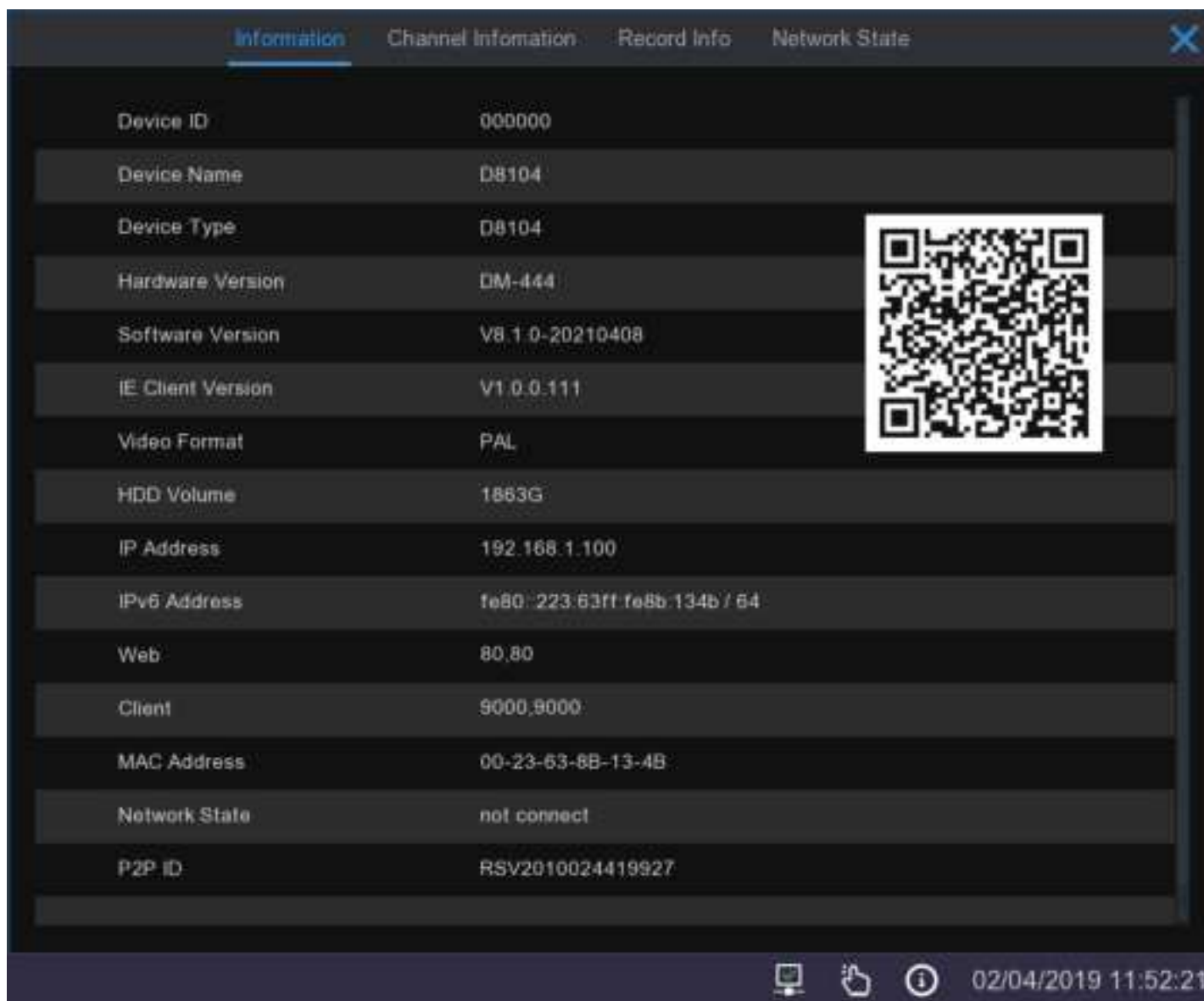

The screenshot shows a dark-themed window titled "Information" with a close button (X) in the top right corner. The window displays a list of system settings and a QR code. The settings are as follows:

Device ID	000000
Device Name	D8104
Device Type	D8104
Hardware Version	DM-444
Software Version	V8.1.0-20210408
IE Client Version	V1.0.0.111
Video Format	PAL
HDD Volume	1863G
IP Address	192.168.1.100
IPv6 Address	fe80::223:63ff:fe8b:134b / 64
Web	80,80
Client	9000,9000
MAC Address	00-23-63-6B-13-4B
Network State	not connect
P2P ID	RSV2010024419927

A QR code is displayed on the right side of the window, which can be used to add the system to a phone app. The bottom of the window shows a taskbar with icons for a monitor, a hand, an information icon, and a timestamp: 02/04/2019 11:52:21.

Chapter 5 Live View

5.5.2 Channel Information

The next tab in the System Information window is Channel Information which gives you a summary of the settings for each channel including online status, resolution for each stream, frame rate set for each stream and the amount of bandwidth (Mbps) being used for each stream.

This window makes it easy to see which channels and streams you can adjust to reduce the amount of storage being used.

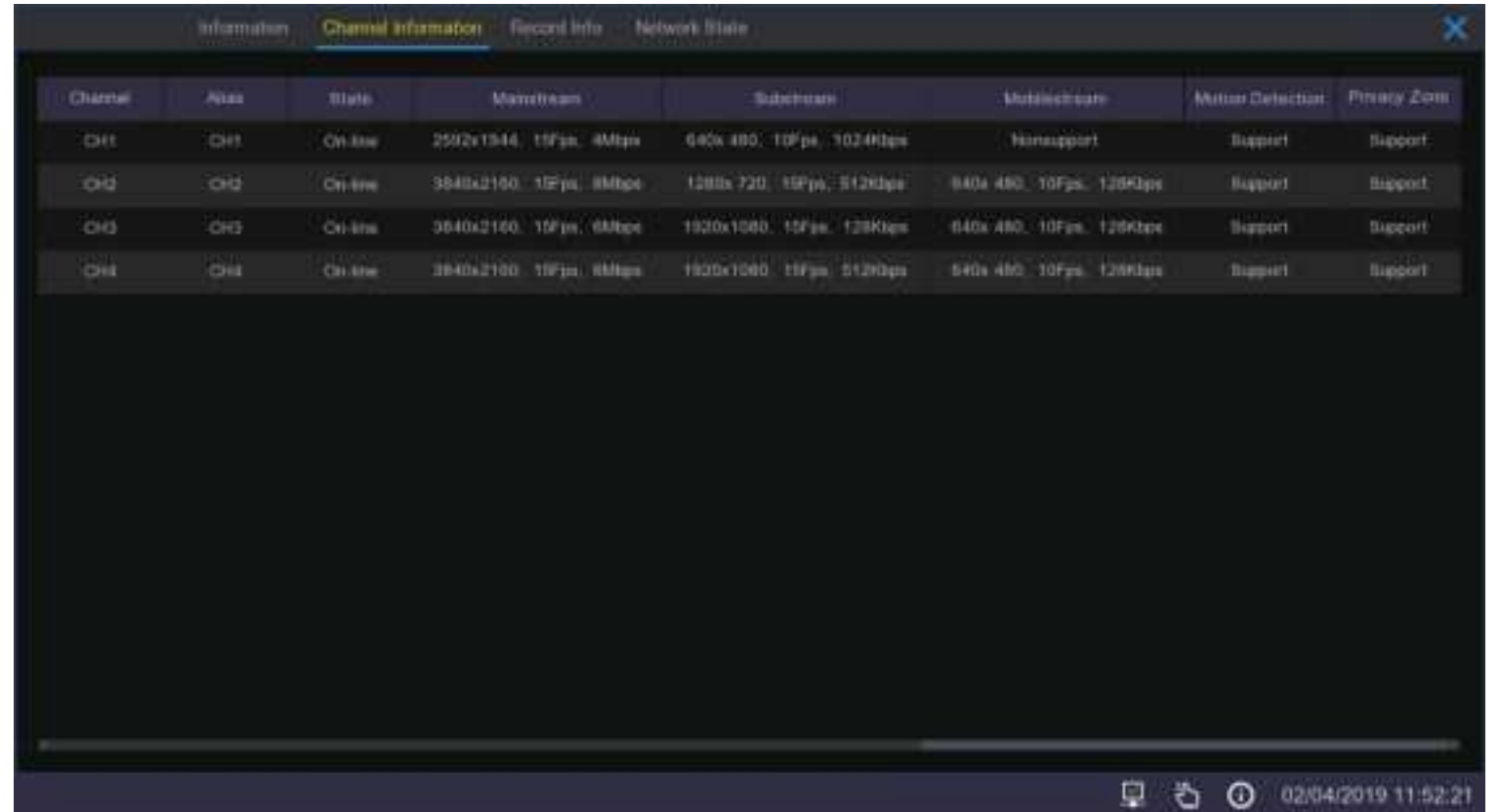

The screenshot shows a window titled 'Channel Information' with a dark theme. It contains a table with the following columns: Channel, Alias, State, Mainstream, Substream, Multistream, Mutual Detection, and Privacy Zone. The table lists four channels (CH1, CH2, CH3, CH4) with their respective settings.

Channel	Alias	State	Mainstream	Substream	Multistream	Mutual Detection	Privacy Zone
CH1	CH1	On-line	2592x1544, 15Fps, 4Mbps	640x 480, 10Fps, 1024Kbps	None	Support	Support
CH2	CH2	On-line	3840x2160, 15Fps, 8Mbps	1280x 720, 15Fps, 512Kbps	640x 480, 10Fps, 128Kbps	Support	Support
CH3	CH3	On-line	3840x2160, 15Fps, 8Mbps	1920x1080, 15Fps, 128Kbps	640x 480, 10Fps, 128Kbps	Support	Support
CH4	CH4	On-line	3840x2160, 15Fps, 8Mbps	1920x1080, 15Fps, 512Kbps	640x 480, 10Fps, 128Kbps	Support	Support

The window also has a status bar at the bottom right showing the date and time: 02/04/2019 11:52:21.

Chapter 5 Live View

5.5.3 Record Info

Under the **Record Info** tab you will find information on any channels that are currently recording. It will show you the weather or not the channel is recording under **Record State**, which stream it is recording at under **Stream Type** and the **Resolution** at which it is recording. For each channel that is recording you can also check the frame rate (**FPS**) and the **Bitrate** that it is being used.

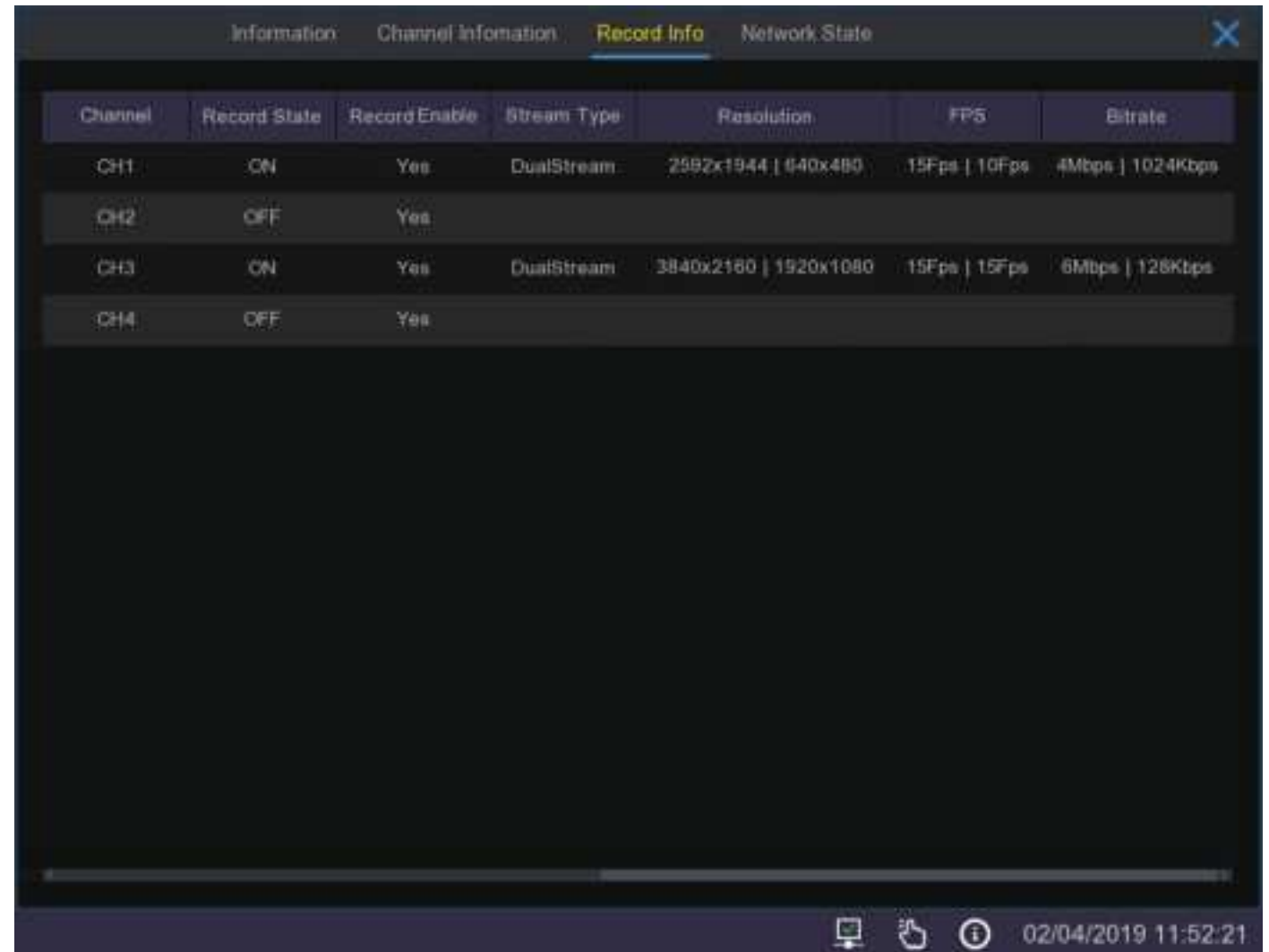

Channel	Record State	Record Enable	Stream Type	Resolution	FPS	Bitrate
CH1	ON	Yes	DualStream	2992x1944 640x480	15Fps 10Fps	4Mbps 1024Kbps
CH2	OFF	Yes				
CH3	ON	Yes	DualStream	3840x2160 1920x1080	15Fps 15Fps	6Mbps 128Kbps
CH4	OFF	Yes				

Chapter 5 Live View

5.5.4 Network State

Under the **Network State** tab you will find a summary of the network settings for your system.

You may need this information when connecting to your system through a network.

Attribute	Value
WAN	
IP Address	192.168.1.100
Subnet Mask	255.255.255.0
Gateway	0.0.0.0
MAC Address	00-23-63-88-13-48
IPv6 Address	fe80::223:63ff:fe8b:134b/64
IPv6 Gateway	fe80::64
DHCP	Enable
DNS1	192.168.1.1
DNS2	8.8.8.8
PPPoE	Disable
3G	Disable
Port	
Web	80,80,Inactive,Disable
Client	9000,9000,Inactive,Disable
RTSP	554,554,Inactive,Disable
Https	443,443,Inactive,Disable
Total Band Width:	8Mbps
Used Band Width:	0bps

System Setup

When you click on the setup icon  in the start menu, after you have entered your password you will be taken to this screen where you can select where you want to go in the System Setup Menu. Here you are able to configure the settings for Channel, Record, Alarm, Network, Device & System.

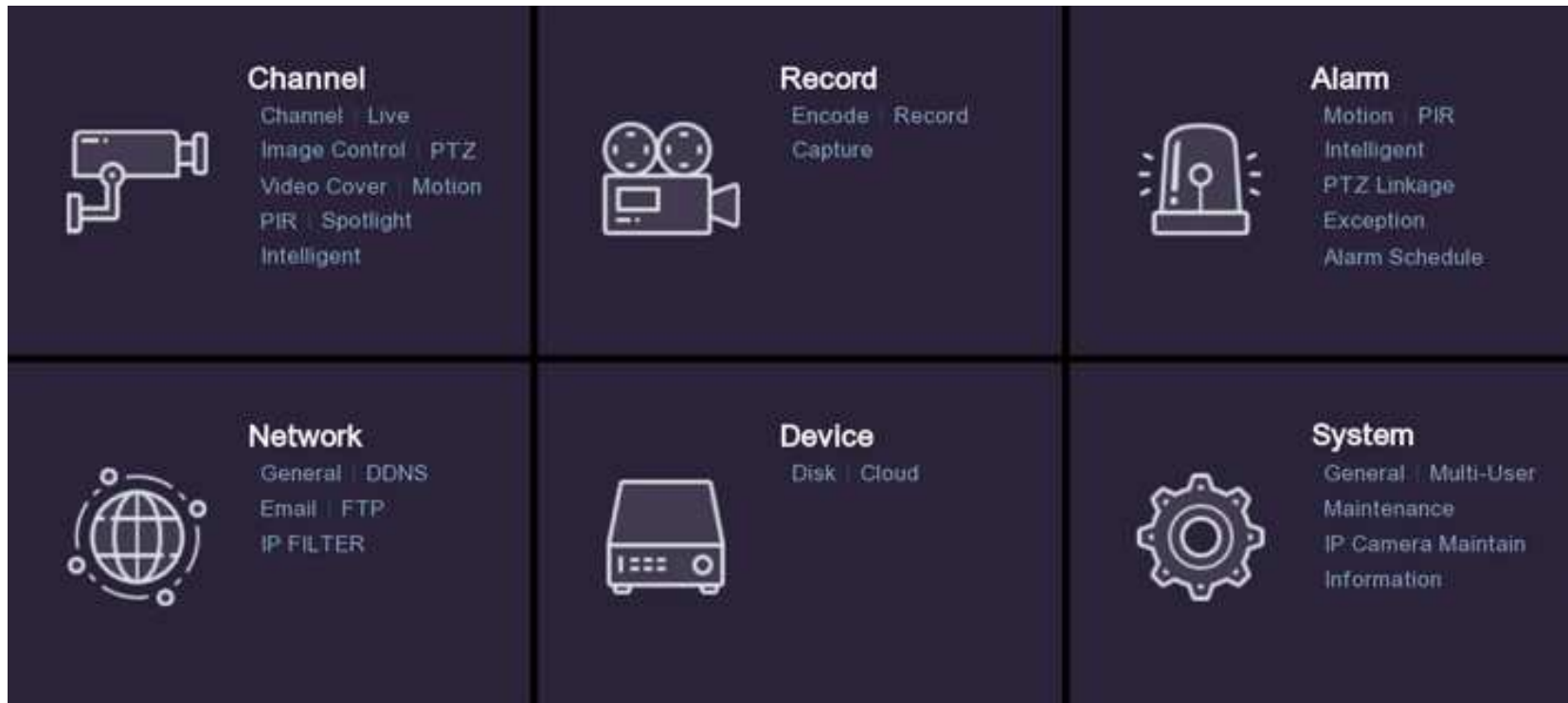

Chapter 6 Channel Setup

6.1 General Controls

When you are setting up your system there are a few processes that are common throughout that are worth remembering:

1. Wherever you see the **Setup** symbol  means you are able to make further adjustments to this feature by clicking on the symbol.
2. To make a change in settings active, in most menus, you will need to click on the **Apply** button.
3. Many settings can be changed in the main menu of a feature by ticking a selection box or selecting a drop down menu next to the relevant channel. So if you don't have anything else to change you can make it quickly and simply in this menu.



4. To exit a menu and go back to the previous menu simply click on the right mouse button.
5. Some menus will not have an **Apply** button to make them active, in these menus your selection will be made active when you exit the menu using the right click button on the mouse.
6. Whenever you set a feature such as **Motion Detect** or **PIR Detect** you need to make sure that it is scheduled to operate through the **Record / Record Schedule**.
7. The **Copy** button can be used to apply all settings to the other cameras on all days or specific days.

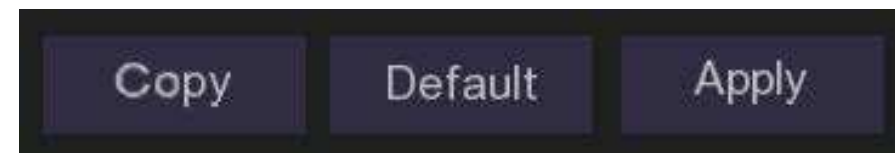

Chapter 6 Channel Setup

6.2 Channel Menu

Under the top Channel Menu tab you can click on the lower Channel menu on the left of the screen and this will bring up three tabs to the right for:

Analogue Channels

IP Channels

Protocol Management

These tabs give you a summary of your settings including AHD cameras, IP connections and sub-stream connections. You shouldn't have to change anything here.

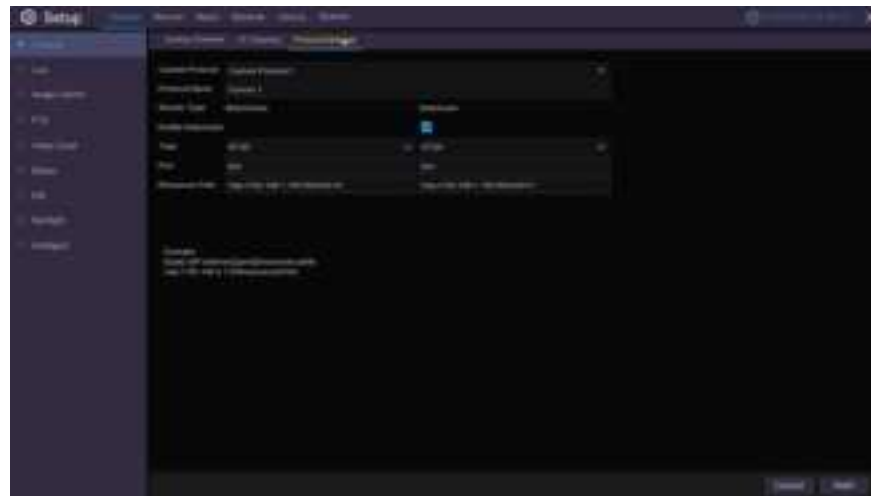
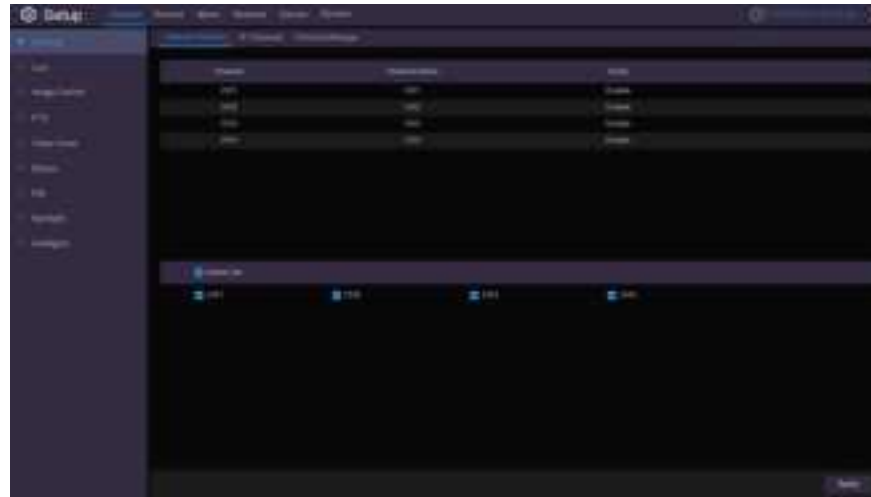

Chapter 6 Channel Setup

6.2.1 Channel Live Menu

The next menu on the left of the screen is the Live menu, in this menu you can adjust various parameters of the cameras.

Each camera is identified by their channel number.

In order to change settings for a camera click on the Setup  icon.

You can also select to show the camera name, show the time, select camera type and adjust EQ Levels from the tick boxes and drop down menus to the right instead of going through the Setup menu.

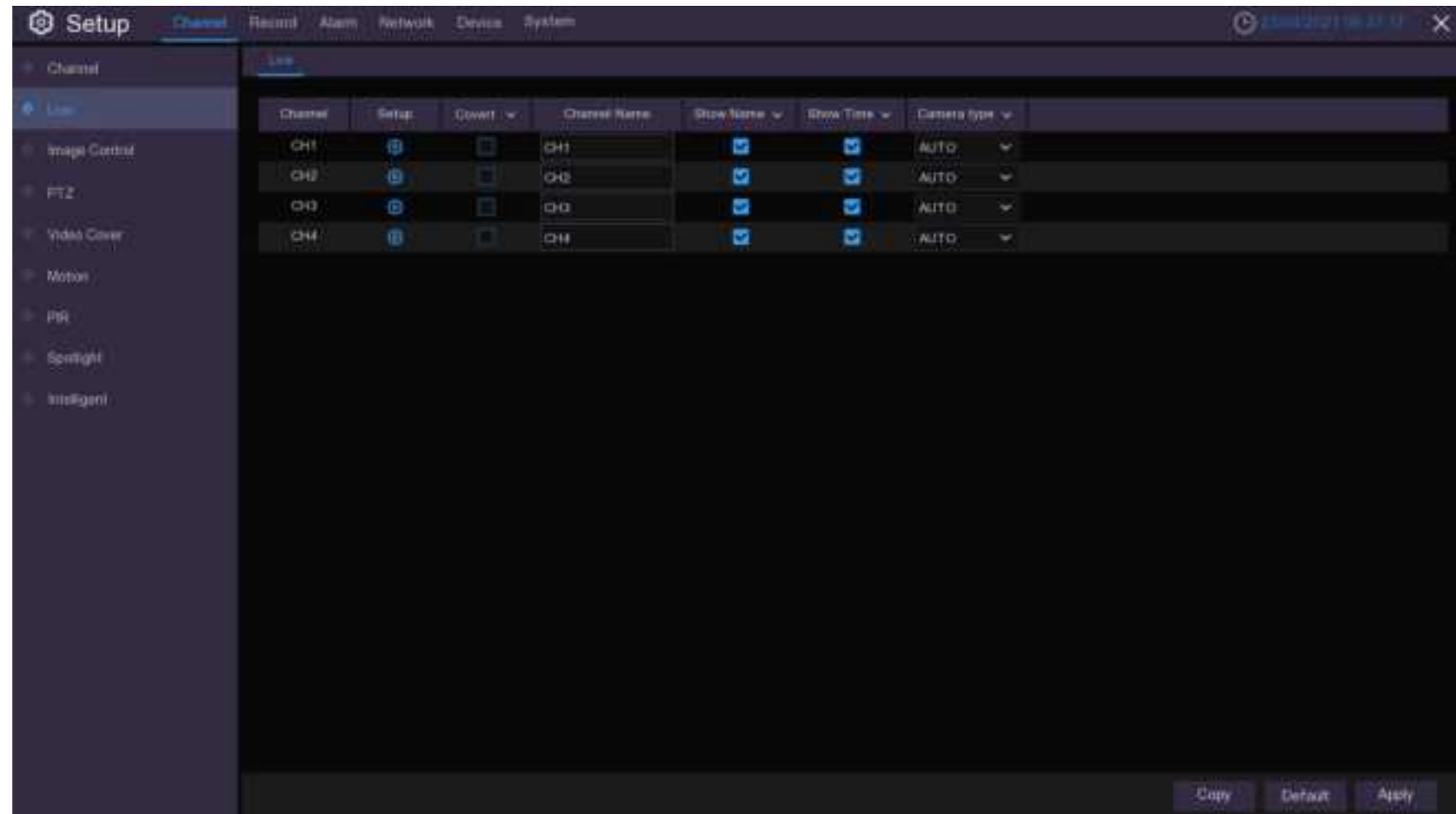

Chapter 6 Channel Setup

6.2.2 Channel Live Display Setup Menu

This menu allows you to configure how the cameras display themselves on screen, including name, date and colour controls.

You can add a name to the channel numbers to identify each camera. Simply click in the **Channel Name** box and type the name you want to use and click **Apply**.

You can change the camera protocol if you have a camera that you want to add to the network you can select from four different AHD formats, TVI and CVI, this is only necessary if you are adding a non-Concord camera.

The **EQ Level** is usually best left at **AUTO**, however if you are running extra long cables you can select a specific length for a better picture, if that is the cause.

If you want to hide the live image of a channel you can tick the **Covert** box, likewise if you want to hide the channel name or the time from the live screen you can untick them on this screen.

Your Concord cameras will automatically adjust to the ambient light conditions, however you may still find you want to adjust the hue, brightness, contrast and colour saturation. You can do this with the sliders at the bottom of the menu and check the effect this has on the live image to the right.



Chapter 6 Channel Setup

6.3 Channel Image Control Menu

This menu is only available for supported IP cameras. If you are using IP cameras refer to one of the Concord NVR manuals for details on how to use this menu.

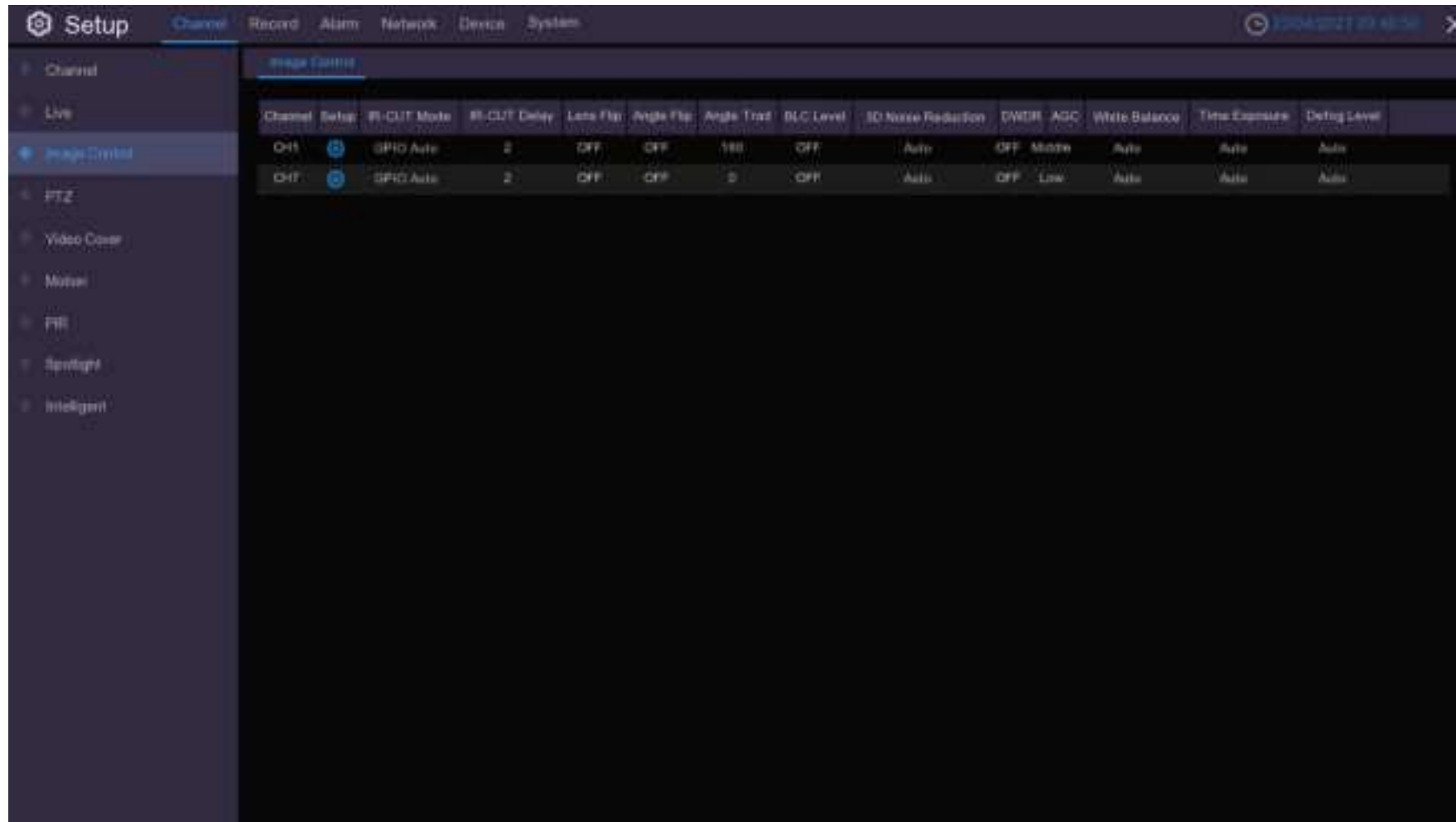

Chapter 6 Channel Setup

6.4 Channel Pan-Tilt-Zoom (PTZ) Menu

This menu is for setting up Pan-Tilt-Zoom cameras which are covered in a separate manual.

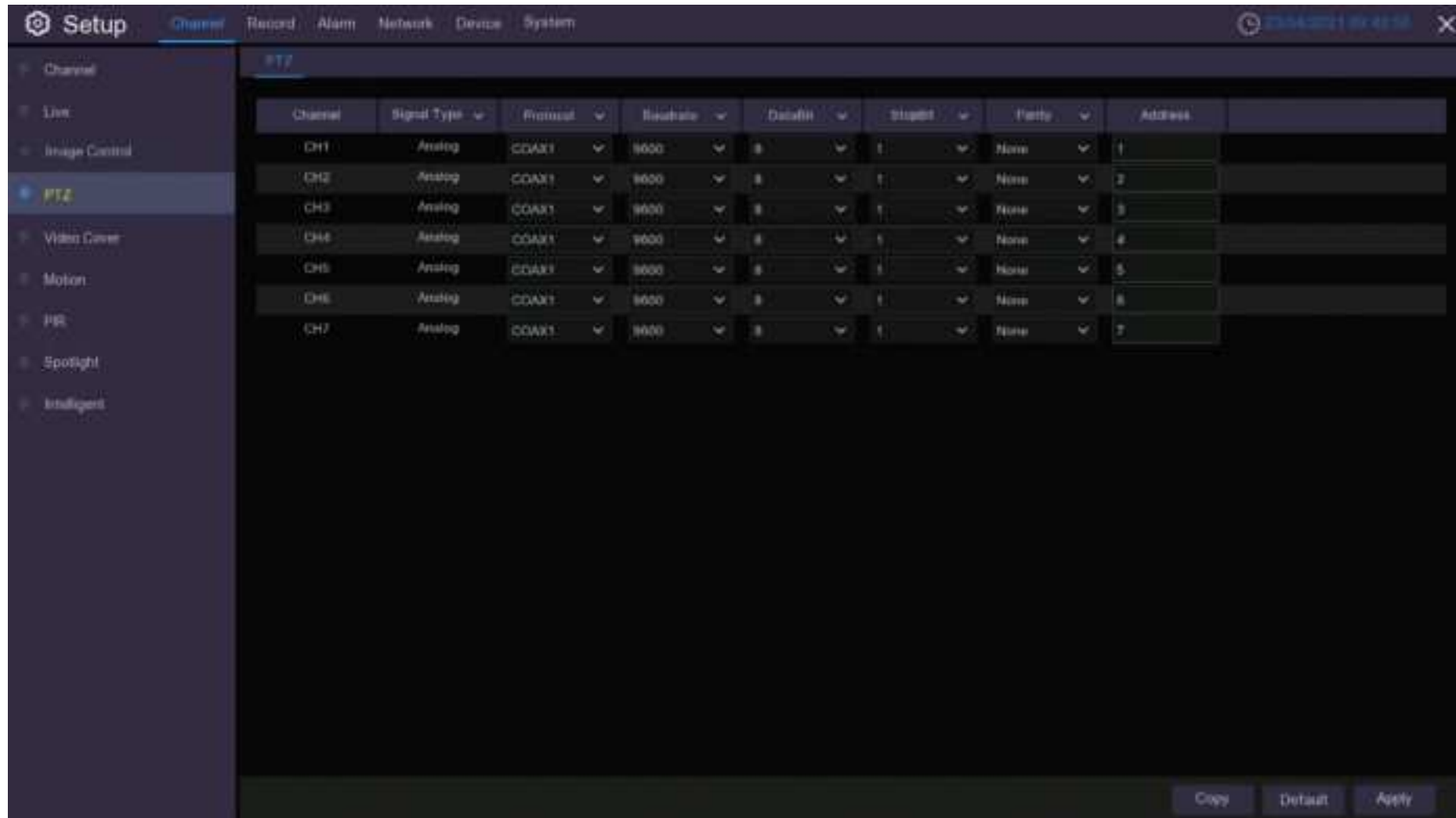

The screenshot shows the PTZ menu in a camera setup interface. The interface has a dark theme with a sidebar on the left and a main content area on the right. The sidebar contains the following menu items: Channel, Live, Image Control, PTZ (highlighted), Video Cover, Motion, IR, Spotlight, and Intelligent. The main content area displays a table with 7 columns: Channel, Signal Type, Protocol, Baudrate, DataBit, StopBit, Parity, and Address. The table contains 7 rows of data, each representing a channel configuration.

Channel	Signal Type	Protocol	Baudrate	DataBit	StopBit	Parity	Address
CH1	Analog	COAX1	9600	8	1	None	1
CH2	Analog	COAX1	9600	8	1	None	2
CH3	Analog	COAX1	9600	8	1	None	3
CH4	Analog	COAX1	9600	8	1	None	4
CH5	Analog	COAX1	9600	8	1	None	5
CH6	Analog	COAX1	9600	8	1	None	6
CH7	Analog	COAX1	9600	8	1	None	7

At the bottom right of the main content area, there are three buttons: Copy, Default, and Apply.

Chapter 6 Channel Setup

6.5 Video Capture Menus

Before going on in this manual it is important to understand that **Concord Digital Video Recorders** are capable of recording and sending alerts of events in three different ways:

1. **Continuous recording** – the camera records continuously until it fills up your **Hard Disk Drive (HDD)** storage and begins recording over the old videos from the beginning.
2. **Motion** – the camera records only if a moving object is detected by the camera.
3. **PIR** – using the signal from the PIR sensor the camera utilises its **Thermal Detect** algorithm to determine if the moving object is a different temperature to the surrounding area, only if it fits that profile will it begin recording.

The following menus allow you to set up these recording methods and fine tune them so you only record events that are relevant to you and minimise how much of your storage you are using.

Chapter 6 Channel Setup

6.6 Video Cover Menu

Video cover can be used to mask off areas that you don't want recorded for privacy reasons, such as a children's play area or a neighbour's yard whose privacy you wish to respect or areas such as footpaths and streets to minimise false triggers from passing traffic. You can set up to four areas to cover.

To create a cover click a number and then draw a rectangle on the screen by drawing down on the bottom right hand corner. To move the mask, click and hold down on the number and move it the location you want to cover.

When you are finished, click apply and the masked area will turn black, then right click to return to the previous menu.

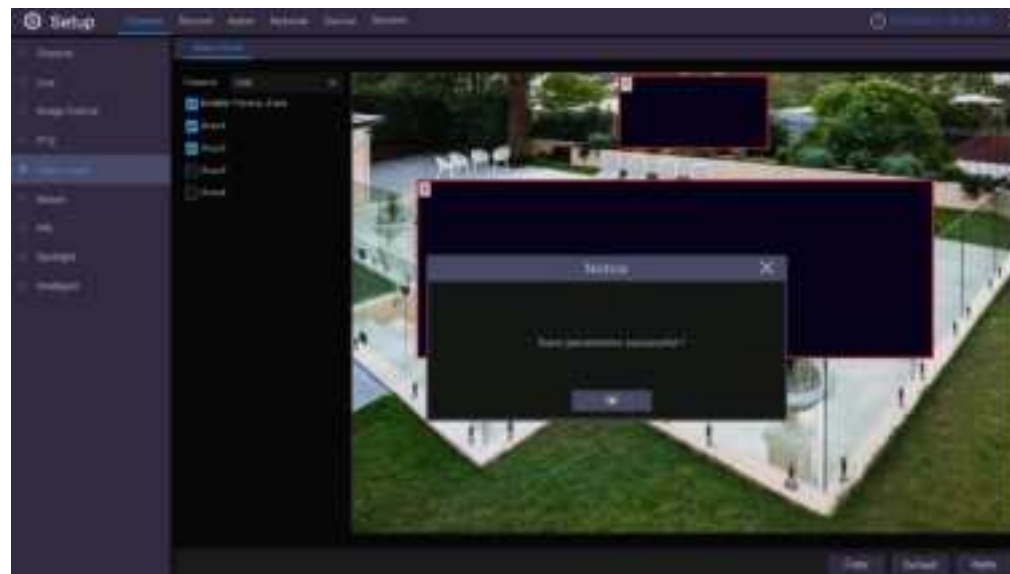
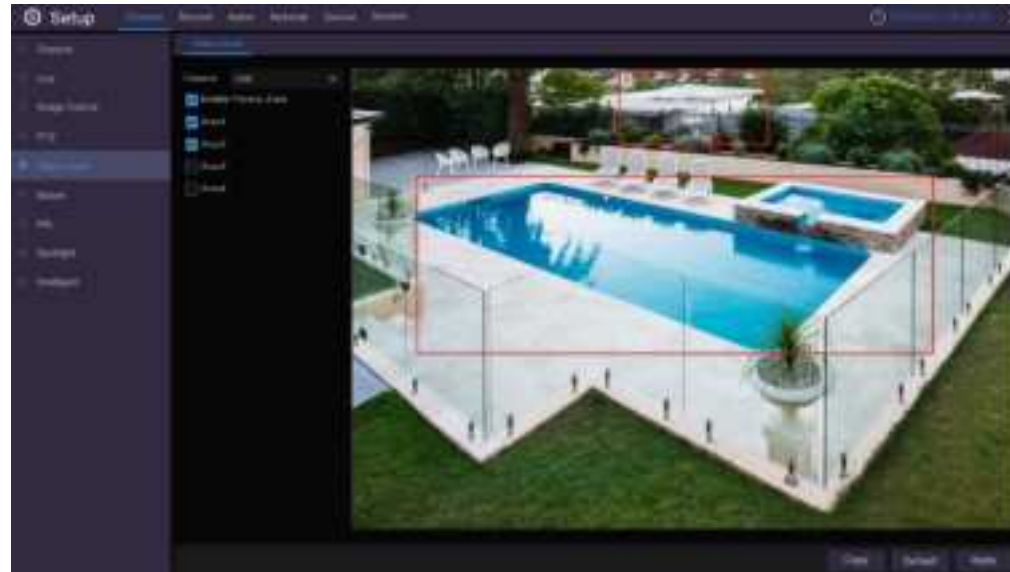

Chapter 6 Channel Setup

6.7 Motion Menu

This menu allows you to configure motion detection parameters for when your cameras are sensing motion only.

When motion has been detected by one or more cameras, your DVR will begin recording and alert you to a potential threat by sending a push notification via the mobile app and/or sending you an email alert with an attached image from the camera to use as a reference (if this option is enabled).

There are various settings within the Motion Setup menu to help minimise the number of false alerts that are recorded and sent. Click on the setup  button to adjust the settings for motion detection.

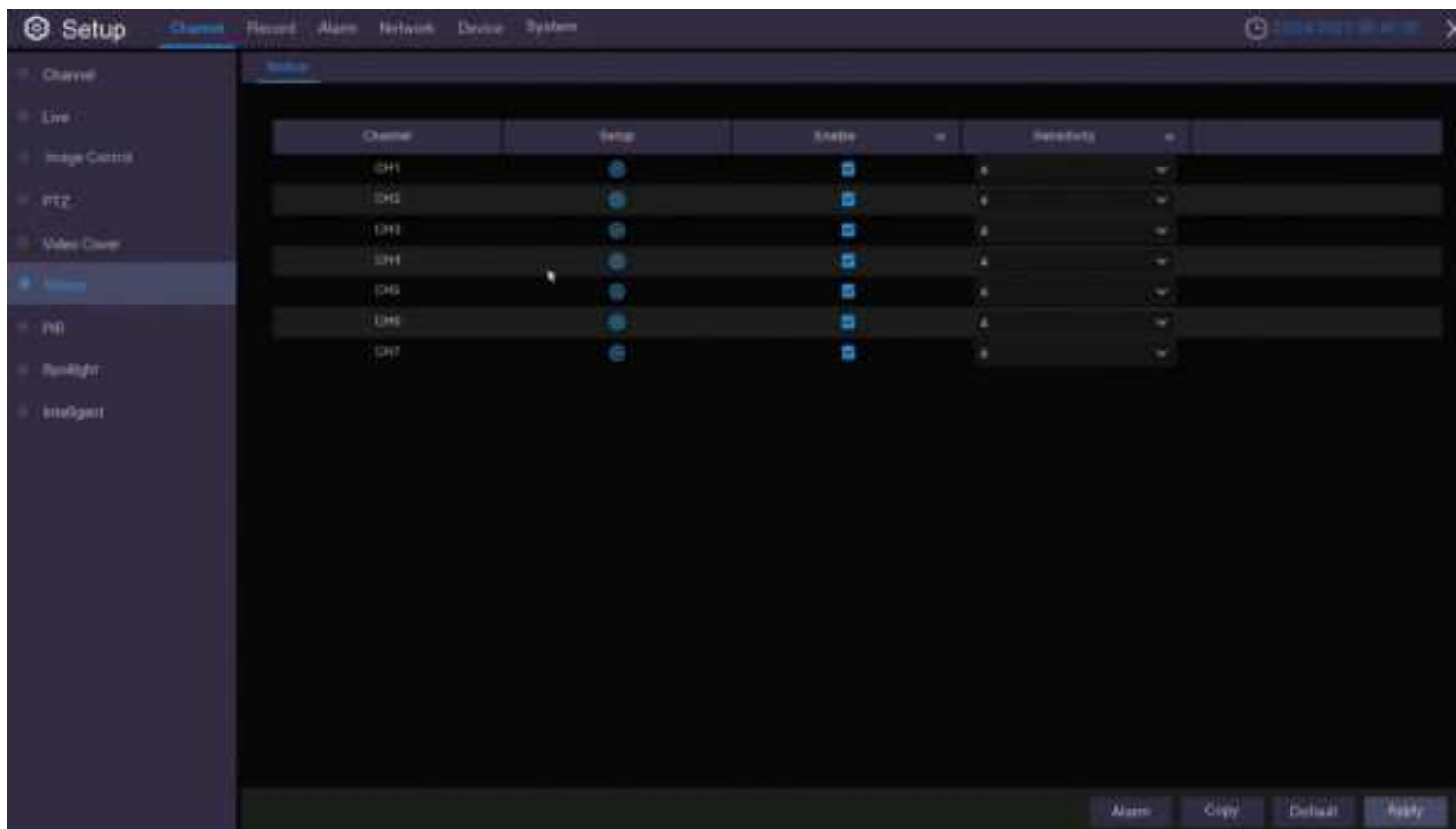

Chapter 6 Channel Setup

6.7.1 Motion Detection Set-up

To minimize the number of events that are recorded and alerted you can filter out unwanted detections. You can do this by limiting the area of detection or reducing the sensitivity of the motion detection.

The image covered in red squares is a live image from the camera you are editing, anything that moves in an area covered by a red square will trigger an event. To reduce the number of triggers you can simply change the motion detection area so it is only covering areas that you want detected. To remove motion detection, click on a square where you want to start, this will remove the red from that square, and drag the cursor to clear the desired non-detection area of red squares. This area will now not be detected. This is a useful tool if you want to mask off an area such as a footpath or street.

If you want to reduce the chance of an alert being triggered by a dog or cat passing or something far away, you can reduce the sensitivity level in the Sensitivity drop down menu.

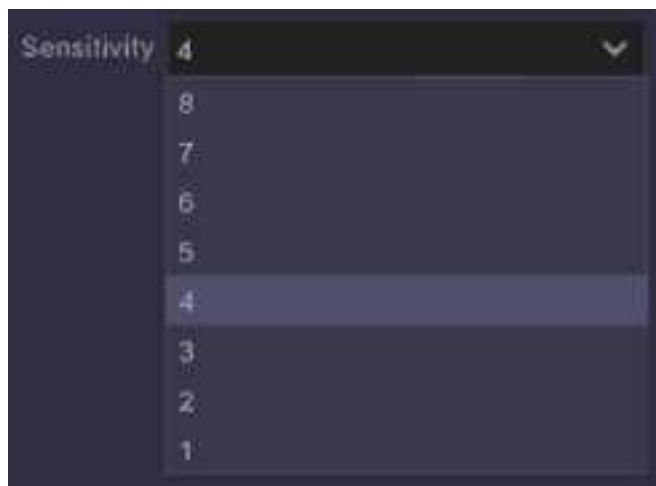

Chapter 6 Channel Setup

6.8 PIR Set-up

While Motion Detection is ideal for areas where there usually isn't any motion such as the interior of a home when everyone is out, the same isn't necessarily true for the exteriors. Here you could have trees moving in the wind, or washing on the clothes line or any number of objects that move regularly that you don't need to record. This is when you use your camera's Passive Infrared sensor (PIR sensor), which will detect whether a moving object is a different temperature to the ambient temperature around.

All Concord cameras include PIR sensors at the front, these sensors detect the infrared radiation that is emitted from the surfaces in front of them. If an object moves through the area the sensor is detecting and the temperature of that object is different to the rest of the area, this will trigger an event. We call this technology Thermal Detect. This means only warm blooded animals (not reptiles) and vehicles will be detected because their radiated heat will be different to the surrounding area.

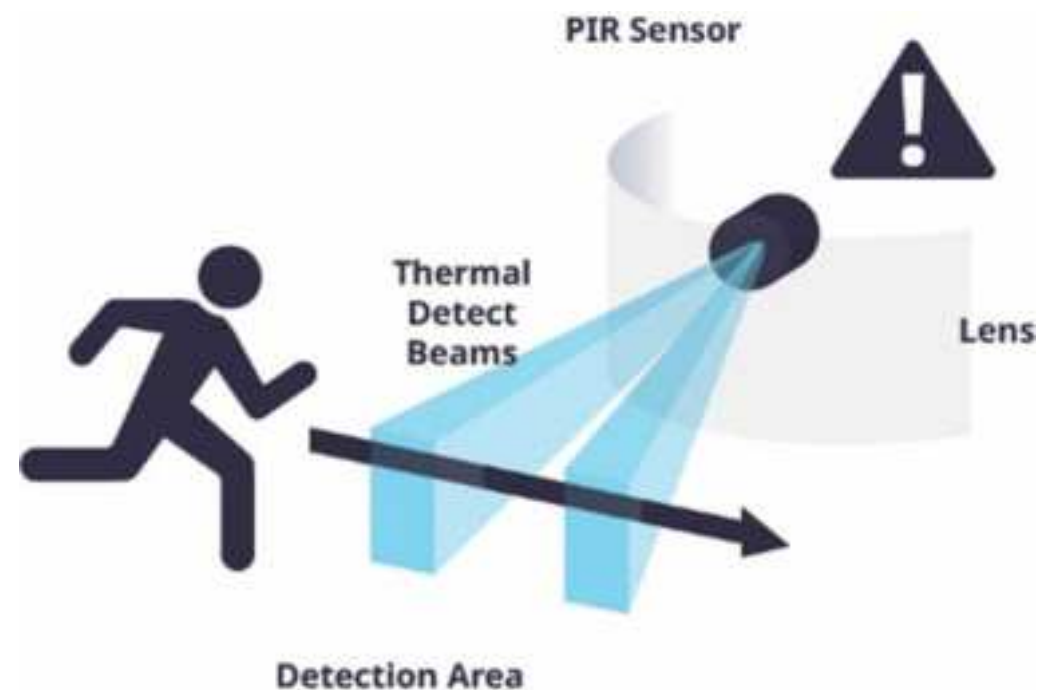

Chapter 6 Channel Setup

6.8 PIR Setup

As with the Motion Detection setup, you are able to adjust the sensitivity of the Thermal Detect so there is less chance that a smaller animal such as a cat or dog will trigger an event. Once you have finished your settings right click on the mouse and click apply in the main menu.

The screenshot shows the 'Setup' menu with 'Channel' selected. The 'PIR' sub-menu is active, displaying a table with columns for 'Channel', 'Setup', 'Enable', and 'Sensitivity'. The 'PIR' menu item in the left sidebar is highlighted with a red box. The 'Setup' column in the table for 'CH3' is also highlighted with a red box, showing a gear icon.

Channel	Setup	Enable	Sensitivity
CH3		<input checked="" type="checkbox"/>	4

Chapter 6 Channel Setup

6.8 PIR Setup

The PIR setup menu uses a line drawing method to determine the area. Simply click on a point to start the shape of the Thermal Detect is active, drag the yellow line across to a point that will form a corner of the detection area, release the mouse button and then click and drag to the next point, repeat this process five times until you have drawn the shape you require to cover the area you wish to detect within. There are six points that you need to connect so you are not limited to simply drawing a four sided rhombus, when complete click in the red square and the lines will turn red indicating the active area.



6.9 Intelligent Set-up

When using 4K cameras with a Network Video Recorder there are a number of functions that become available to you; however these functions, although visible on some menus are not available with Digital Video Recorders.

Chapter 7 Record Setup

In Channel Setup the aim was to fine tune your system so it was only recording events that you actually wanted to keep in the Record section of System Setup it is all about how you want to store your event recordings and how you can best use your space. This is all about the balance between high quality images and storage space; generally the higher quality the image the more space it takes up, but there are adjustments you can make that can keep storage low and still maintain image quality.

In this chapter you will find explanations and settings for:

Stream Type

Resolution

Frame Rate

Video Compression

Bitrate Control

Bitrate Mode

Record

Capture

Alarm

You can also choose to record video and still images. Setup for video recording is done in the **“Record”** menu, setup for still images is done in the **“Capture”** menu.

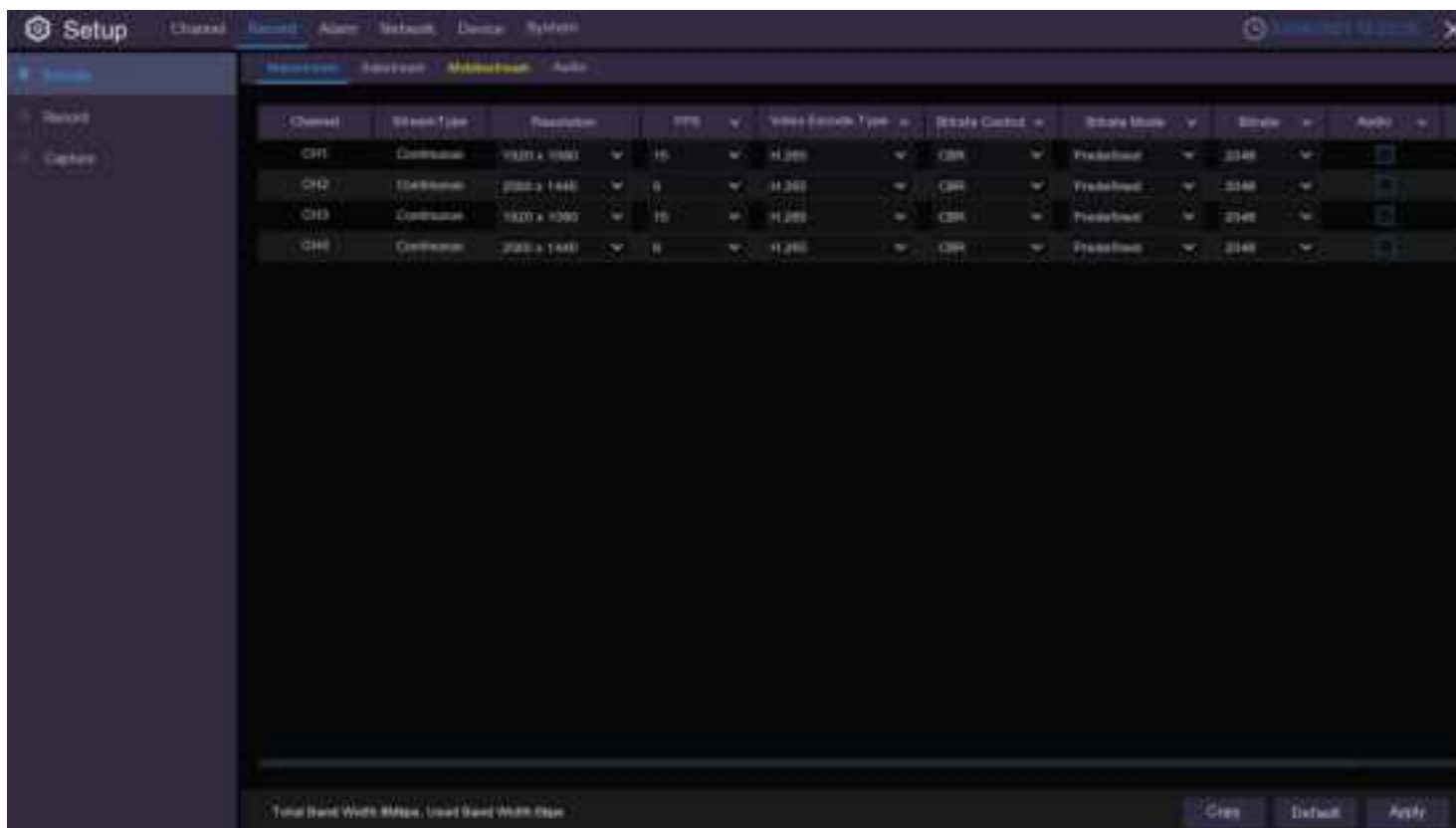

Chapter 7 Record Setup

7.1 Stream Type

The first page you will see under the Record tab is the Encode page this is where you will make adjustments to the recording streams, recording resolution and how your recordings are encoded.

In your system there are three streams that you can record to, this is done so that you can store different bit rates for different viewing devices. There is a “Mainstream” that you can record at your highest resolution and bit rate to view on your monitor, a “Substream” to view via the online portal and a “Mobile Stream” to view on the mobile app. If you have good internet connection where you would normally use an online portal or don’t intend to use the portal and only use the mobile app when you wish to check alerts then you could select not to record on the “Substream” or “Mobile Stream”, this will save you a lot of storage space.

The streams are set to default as below but you can adjust these :

Mainstream – defaults to highest resolution

Substream – defaults to a lower resolution

Mobile stream – defaults to the lowest resolution

Each stream can be modified through the Encode menu which is detailed in the next section of this manual.

Channel	StreamType	Resolution
CH1	Continuous	1920 x 1080
CH2	Continuous	2560 x 1440

Chapter 7 Record Setup

7.2 Encode

The purpose of the Encode menu is to fine tune the resolution, frame rate, compression and bitrate settings at which each channel (camera) records. It is very likely you will not need each channel to be recording at exactly the same resolution, frame rate and bitrate and reducing the settings of some of these elements can greatly assist you in reducing the amount of data that you store on your HDD or cloud storage. These settings can be individually adjusted in Mainstream, Substream and Mobilestream.

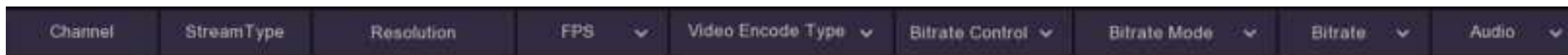

Total Band Width: Your DVR has a maximum bandwidth that it can process, depending on the model and the number of channels being used this will be either 8Mbps – 24Mbps or 16Mbps – 48Mbps or 32Mbps – 96Mbps. Adjusting settings within the Encode menu will affect how much you are using. It is a good idea to check how much bandwidth you are using with your current settings by looking at the message at the bottom of the Encode page. “Total Band Width” is the total you have available and “Used Band Width” is how much of the available capacity you are using.

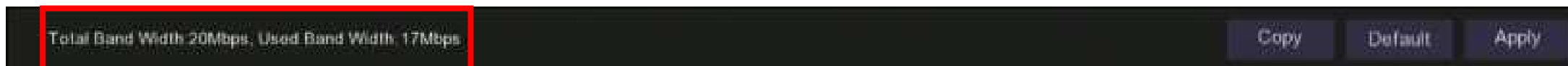

Chapter 7 Record Setup

7.2.1 Encode Resolution

One of the biggest contributors to how much data you use in a recording is the resolution at which you record it. You may find, especially if the camera is close to the subject such as a cash area in a store or monitoring a front door, that you don't need all the resolution you have available to be able to see the detail you need. In this case a lot of space can be saved by reducing the resolution being used or just using a lower resolution camera in that area.

Resolution: You can select the resolution you wish to use from the drop down menu under Resolution. This field will default to the highest resolution possible for the camera that is connected to that channel. However there is nothing stopping you from setting this to the very lowest value that can be selected or anything in between, it's up to you to decide what works for you.

Channel	StreamType	Resolution	▼
CH1	Normal	1920 x 1080	▼
CH2	Normal	1280 x 1944	▼
CH3	Normal	1920 x 1080	▼
CH4	Normal	1280 x 1944	▼
CH5	Normal	1920 x 1080	▼
CH6	Normal	1280 x 1944	▼
CH7	Normal	1280 x 1944	▼

Chapter 7 Record Setup

7.2.2 Encode FPS (Frames Per Second)

Frame rate is the amount of individual images that are put together to make one second of video or frames per second (FPS). In CCTV cameras you can adjust the number of images that are used to make up a second of video, less images used equals less storage used.

There is a trade off in video quality when reducing the frame rate, keeping in mind that 24fps is the standard for cinema so video around this frame rate will look natural, anything below about 15fps will start to look a little jerky and unnatural. However, the purpose of CCTV is not to make cinematic masterpieces, it is to record events to check for details later on. So long as the frame rate is high enough to capture images to be able to identify an intruder the smoothness of the video doesn't really matter.

FPS: To adjust your frame rate select the value you want from the FPS drop down menu.

The menu will automatically update the rates based on the camera being used and the resolution selected; generally the lower the resolution the higher the available frame rate will be.

You may notice in the machine specifications there is a difference between the maximum FPS of your recorder and your camera, this is because your recorder is designed to work with a higher rate in case you add a camera that has the ability to work at a higher rate.

Reducing frame rate is one of the biggest savings you can make on storage space and is definitely one of the first things you should adjust when trying to minimise bandwidth. You will need to use a bit of trial and error to determine what is the optimum setting for your situation.

Channel	StreamType	Resolution	FPS
CH1	Normal	1920 x 1080	15
CH2	Normal	1280 x 1944	15
CH3	Normal	1920 x 1080	15
CH4	Normal	1280 x 1944	15
CH5	Normal	1920 x 1080	15
CH6	Normal	1280 x 1944	15
CH7	Normal	1280 x 1944	15

Chapter 7 Record Setup

7.2.3 Video Encode Type (H.264, H.265)

Video compression is a means of encoding a digital video file in a way that reduces the size of the file by removing unnecessary or unimportant information. There are many types of video compression, however the two standards that have been adopted by most CCTV manufacturers are called H.264 and H.265.

H.265 is the newer of the two compression formats and it has considerable compression advantages over H.264; it can achieve nearly twice the compression amount at the same video quality. However, not all video playback programs and devices can accept it so you should check the device you are going to play your saved videos on before deciding which standard you are going to use.

Video Encode Type: To change the compression type simply select the type you want from the drop-down menu and click Apply in the bottom right of the page.

Changing to H.265 can make significant savings to your storage space.



FPS	Video Encode Type	Bitrate Control
15	H.265	CBR
15	H.265	CBR
15	H.265	CBR
15	H.265	CBR
15	H.265	CBR
15	H.265	CBR
15	H.265	CBR

Chapter 7 Record Setup

7.2.4 Encode Bitrate Control (Constant or Variable)

One of the main contributors to the amount of bandwidth your system uses is the amount of movement and complexity of the image. The more that is going on in the image, the more storage is required. So a complex garden or interior scene is going to need a more data than a blank grey wall and a busy urban street is going to consume more space than a quiet driveway.

Bitrate Control: Allows you to adjust the bitrate to suit the scene you are recording by switching between CBR and VBR modes:

Constant Bit Rate (CBR): The default setting for your recorder is CBR, in this mode your recorder is always recording at the same bitrate which means the quality of the image will be consistently the same. This is ideal for areas with a lot of movement such as hallways and roads.

Video Encode Type ▾	Bitrate Control ▾	Bitrate Mode ▾	Bitrate ▾
H.265 ▾	CBR ▾	Predefined ▾	2048 ▾
H.265 ▾	CBR ▾	Predefined ▾	2048 ▾
H.265 ▾	CBR ▾	Predefined ▾	2048 ▾
H.265 ▾	CBR ▾	Predefined ▾	2048 ▾
H.265 ▾	CBR ▾	Predefined ▾	2048 ▾
H.265 ▾	CBR ▾	Predefined ▾	2048 ▾
H.265 ▾	CBR ▾	Predefined ▾	2048 ▾

Chapter 7 Record Setup

7.2.4 Encode Bitrate Control (Constant or Variable)

Variable Bit Rate (VBR): If the scene in front of the camera does not vary a lot over time then VBR is ideal and can save you a lot of bandwidth. VBR allows a higher bitrate (and therefore more storage space) to be allocated to more complex images while less space is allocated to less complex images. So while nothing is happening and the image being recorded is constant the recorder will use a lower bitrate but when there is movement in the image, the image becomes more complex so the recorder will use a higher bit rate to capture greater detail.

Video Quality: When you select VBR a new drop-down menu will appear where you can adjust Video Quality to further reduce bandwidth. As with frame rate settings you will need to use a bit of trial and error to determine what are the best settings for you.

Bitrate Control	Bitrate Mode	Bitrate
CBR	Predefined	2048
VBR	Predefined	2048
VBR	Predefined	2048
CBR	Predefined	2048

Chapter 7 Record Setup

7.2.5 Encode Bitrate Mode & Bitrate

Different resolutions use different ranges of bitrate in order to display the best image possible, by default your recorder will select the highest bitrate for the resolution you are using. You can reduce this bitrate to reduce the amount of storage being used, just remember the higher the resolution the higher the bitrate needs to be, so if you drop a 4K camera down too far it will start to look very blurry, on the other hand if you put the bitrate up too high on a lower resolution camera at a certain point it will make no difference to the image quality so you will just be using up bandwidth for no reason.

Bitrate Mode There are two methods to set the bitrate in your DVR:

Predefined: Uses predefined values based on standard bitrate increments.
(Recommended)

User-defined: Here you can set your own bit rate. (Advanced users only)

If you make any changes on this screen make sure you click on the Apply button at the bottom right of the screen to save the changes.

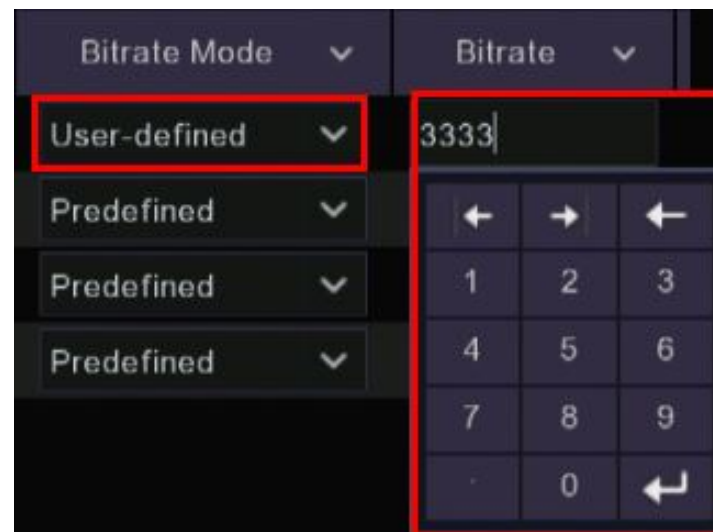
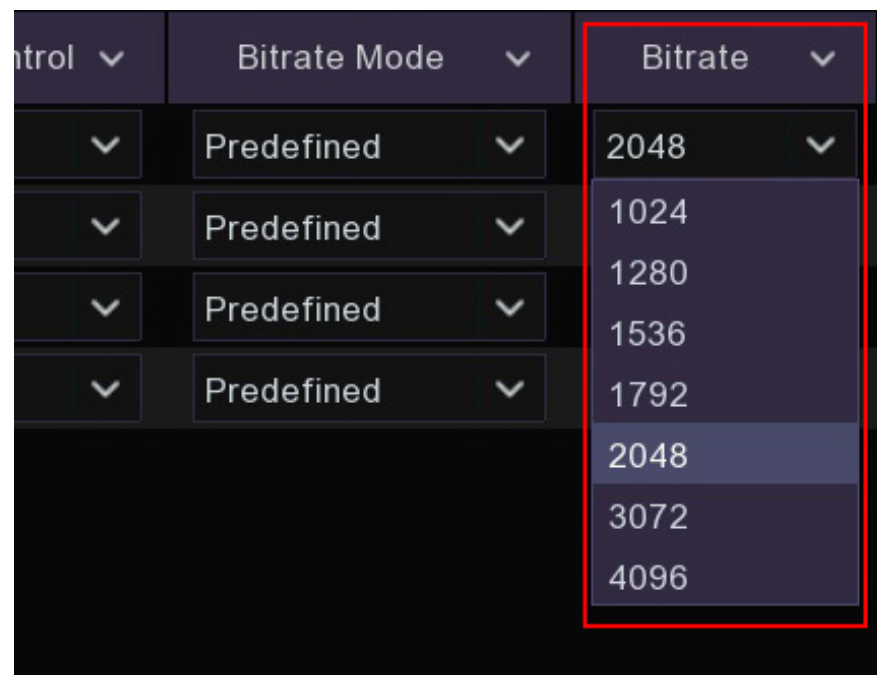

Chapter 7 Record Setup

7.2.5 Encode Bitrate Mode & Bitrate

This table gives recommended bit rates based on the resolution to which you have set the channel. It is intended as a guide to help you fine tune your settings based on optimum frame rates for low bandwidth.

Resolution	Max FPS	Good Bit Rate	Better Bit Rate	Best Bit Rate
1280x720	8	512	640	768
	10	1024	1280	1536
	15	2048	4096	5120
1280x960	8	512	896	1024
	10	1024	1280	1536
	15	2048	4096	5120
1920x1080	8	768	896	1024
	10	1280	1536	2048
	15	4096	5120	6144
2048x1536	8	1280	1536	2048
	10	3072	5120	6144
	15	4096	6144	8192
2304x1296	8	1280	1536	2048
	10	3072	5120	6144
	15	4096	6144	8192
2592x1520	8	3072	5120	6144
	10	4096	6144	8192
	15	4096	6144	8192
2592x1944	8	3072	5120	6144
	10	3072	5120	6144
	15	4096	6144	8192
3840x2160	8	3072	4096	5120
	10	4096	5120	6144
	15	6144	8192	10240

Chapter 7 Record Setup

7.2.6 I Frame Interval

An **I Frame** is an image frame used in video compression as a reference image, typically every 20-30 frames. The compression compares the next frames after the I Frame for any changes and only sends those pixels that have changed. If you find h.264 or h.265 compression is reducing the quality too much you can try to fine tune this by increasing the number of I Frames that are used.

I Frame Interval is adjusted simply by changing the number in the field under I Frame Interval. The lower the number the more frequent the I Frame is used and theoretically the better the video quality. Keep in mind that this adjustment works best with higher frame rates as there are more frames per second with which to work. For example if you have the frame rate set at 5 frames per second and you set the I Frame Interval to 5 then the compression is only able to use one I Frame per second, but if you have the frame rate set at 25 frames per second and the I Frame Interval set to 5 then the compression will use I Frames per second.

Most users should leave the I Frame Interval at the default settings.

Bitrate	Audio	I Frame Interval
8192		30
8192	<input type="checkbox"/>	30
6144	<input type="checkbox"/>	30
6144		30

Chapter 7 Record Setup

7.3 Record

In this menu you can select the cameras you want recording, what their Stream Mode is and whether you want them to Pre-record.

Record Enable can be deselected if you have a camera that you want to use for live view only. Your recorder will detect motion but it will not keep a recording, you will also not be able to use manual record.

Stream Mode is where you select whether to record in DualStream, which will record both the Mainstream resolution and the Substream resolution or Mainstream only. If you intend to use the Mobile App then it is best to keep this set at DualStream.

PreRecord function can also be deactivated in this menu. This function allows your recorder to record a few seconds before an event occurs, this is a useful feature as there could be important footage that occurred just before the recording was triggered, especially if the person triggering the recording has their back to the camera once the recording begins. We recommend you leave this box ticked.

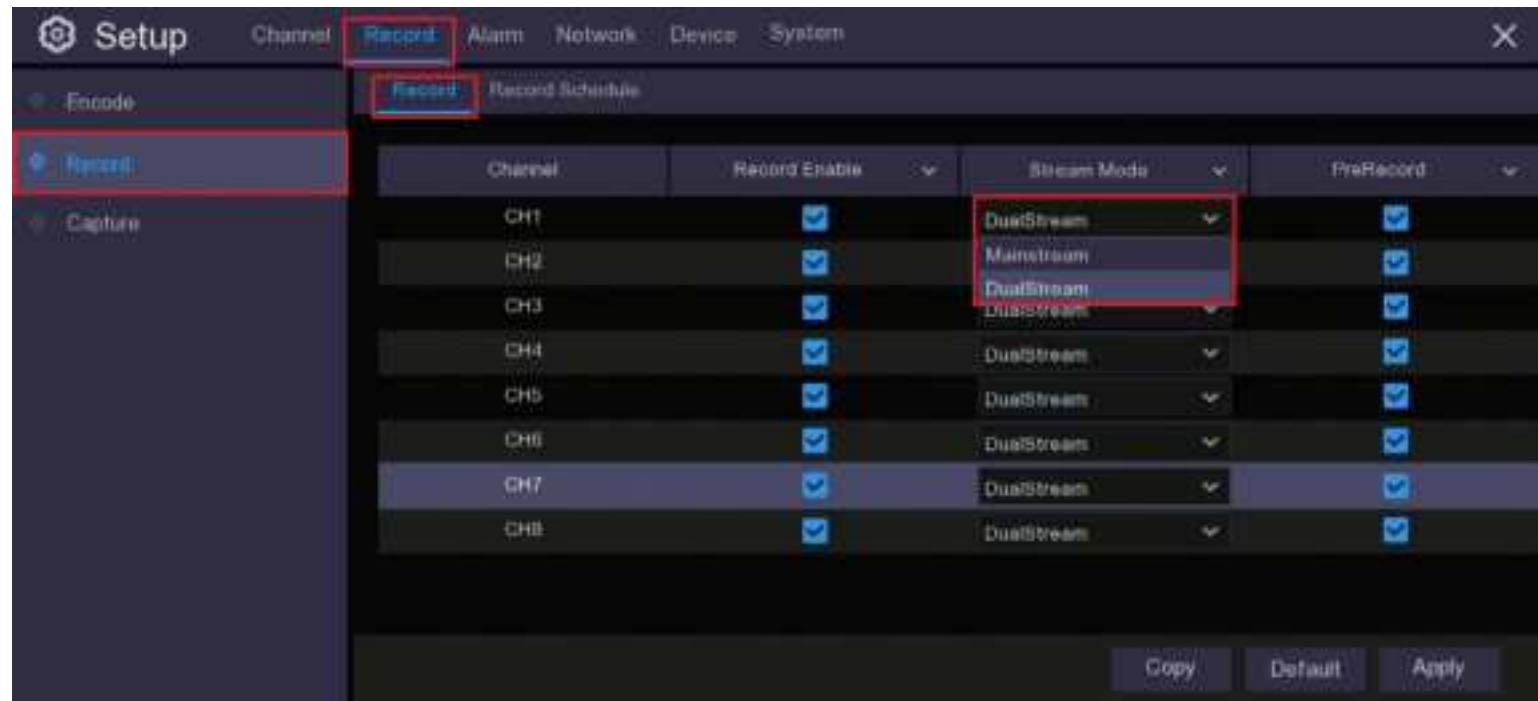

Chapter 7 Record Setup

7.3.1 Record Schedule

Using this function you can access and change the default recording schedule. The Record Schedule is shown as a 7 day grid divided into 48 half hour blocks for each day, you can select which camera you want to schedule by using the Channel drop down menu at the top. The various recording triggers are shown as color coded rings; click inside the ring corresponding to the recording trigger you want to use and then drag the cursor across the days and times you want to select, to deselect an area click or drag across on the cells or you want to remove in the same manner.

You can choose to record all three methods at the same time or separately, it is up to you to decide what best suits your needs. You can filter out the trigger methods in the search and playback menus, however the more methods and times you select the more HDD space you will use.

There are three types of recording that you can schedule:

Continuous – this is continuous recording and fills up your hard drive the fastest.

Motion – this will only trigger a recording when movement is detected by the camera within the defined Motion area.

PIR – this will only trigger a recording when an object that has a different temperature to the back ground temperature passes through the PIR beam.

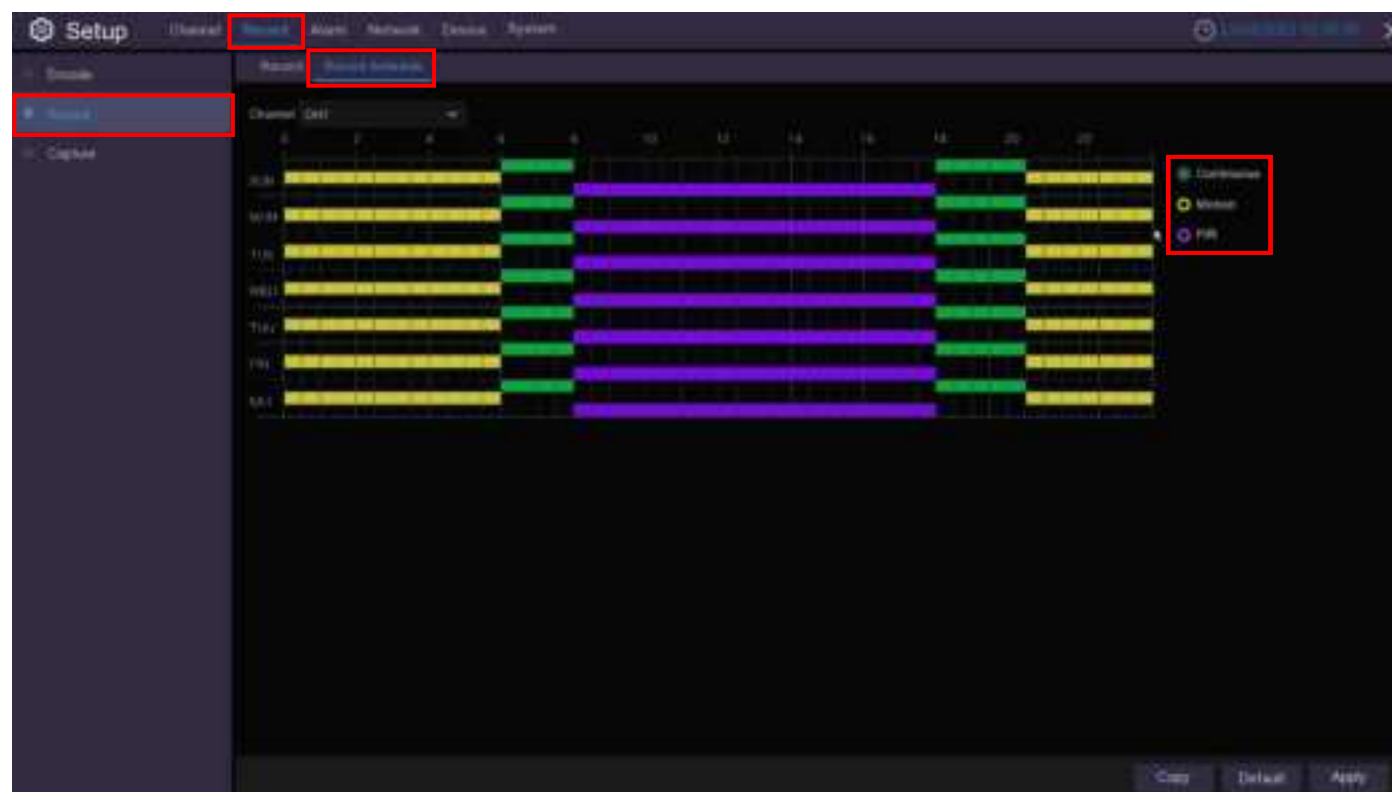

Chapter 7 Record Setup

7.4 Capture Setup

Your Concord recorder has the ability to capture still images of events which can be used to find motion events more quickly, to send to your email as an alarm or to take time lapse images of a scene. Maximum resolution for still image captures is 1080P HD.

Auto Capture: You can choose to turn this feature off by deselecting in this column.

Stream Type: Allows you to select “Mainstream” for high resolution images or “Substream” for lower resolution images; selecting “Substream” can help save space on the HDD.

Normal Interval is the time between taking photographs, for instance at 30s means an image will be taken every 30 seconds.

Alarm Interval is used to set the gap between taking photographs after an alarm has been raised.

The screenshot displays the 'Setup' interface for a Concord recorder, specifically the 'Record' > 'Capture' configuration page. The interface is dark-themed and features a sidebar on the left with 'Capture' selected. The main area contains a table with the following columns: Channel, Auto Capture, Stream Type, Normal Interval, Alarm Interval, Alarm Resolution, and Alarm Quality. The table lists channels CH1 through CH6 and IP CH1 through IP CH6. The 'Stream Type' dropdown for CH1 is open, showing options for Mainstream, Substream, and Mainstream. The 'Auto Capture' column has checkboxes, and the 'Normal Interval' and 'Alarm Interval' columns have dropdown menus set to 5s. The 'Alarm Resolution' column is set to 1280 x 720, and the 'Alarm Quality' column is set to Medium.

Channel	Auto Capture	Stream Type	Normal Interval	Alarm Interval	Alarm Resolution	Alarm Quality
CH1	<input checked="" type="checkbox"/>	Mainstream	5s	5s	1280 x 720	Medium
CH2	<input type="checkbox"/>	Mainstream	5s	5s	1280 x 720	Medium
CH3	<input type="checkbox"/>	Substream	5s	5s	1280 x 720	Medium
CH4	<input type="checkbox"/>	Mainstream	5s	5s	1280 x 720	Medium
IP CH1	<input type="checkbox"/>	Mainstream	5s	5s		
IP CH2	<input type="checkbox"/>	Mainstream	5s	5s		
IP CH3	<input type="checkbox"/>	Mainstream	5s	5s		
IP CH4	<input type="checkbox"/>	Mainstream	5s	5s		
IP CH5	<input type="checkbox"/>	Mainstream	5s	5s		
IP CH6	<input type="checkbox"/>	Mainstream	5s	5s		

Chapter 7 Record Setup

7.5 Motion & PIR Alarm Setup

You can set up your DVR to alert you to a potential threat at your home using the Alarm function to send an email to you and two other recipients, you can also use this function to upload pictures and videos using a file transfer protocol or to a cloud server and to trigger other cameras in your system to begin recording. This function is independent of the App push notifications.

Menu layout and functions for **Alarm** are the same for Motion and **PIR**, so if you want to have the same settings they are easy to copy, or you can turn alarms off for one alert type and on for another, it is up to you and the type of alarms you want to have.

You can also, use the **Copy** button at the bottom right of the screen to copy the settings from one channel to others. To the left of the **Copy** button is a button for **Motion**, **PIR** or Intelligent, this button will take you directly to the settings page for that particular function in case you want to check or change settings for the function while you are setting the alarm.

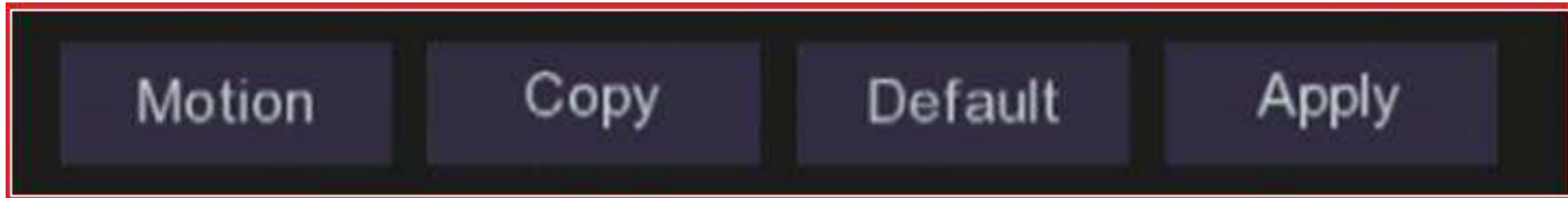

Chapter 7 Record Setup

7.5 Motion & PIR Alarm Setup

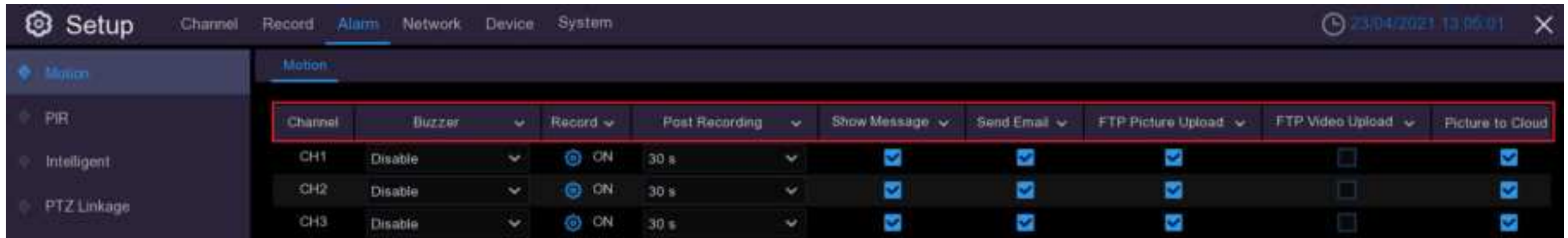

Channel: Channel number being setup.

Buzzer: Internal DVR audible buzzer will sound every time an alarm is triggered.

Record: Switches recording on for other channels and gives you the option to nominate on which channels to begin recording. This increases the chances of capturing an identifying image of an intruder if you missed it on one camera, as another camera will already be recording if they come into its view.

Post Recording: Sets the length of time to record after an alarm. You can choose to record for 30 sec, 1 min, 2 min or 5 min after an alarm has been triggered.

Show Message: Show alarm icons on the live view screen.

Send Email: Send an email alert to the designated email addresses. Under “Network” settings there is an option to setup one to three email addresses. You can choose to have an alert sent to these email addresses when an alarm is triggered through this menu.

Full Screen: Displays the full screen video feed of the triggered camera in Live View mode when alert is activated.

FTP Picture Upload / FTP Video Upload: Upload pictures or upload video captures using File Transfer Protocol. Although largely replaced by cloud servers these days, some people may prefer to upload their alert pictures or alert videos using a FTP server, this can be set up in the Network settings menu.

Picture to Cloud / Video to Cloud: Upload recorded pictures or video captures to Dropbox. You can find details on how to set up a Dropbox account and link your recorder to it can be found in the Device setup menu section of this manual.

Chapter 7 Record Setup

7.5 Motion & PIR Alarm Setup

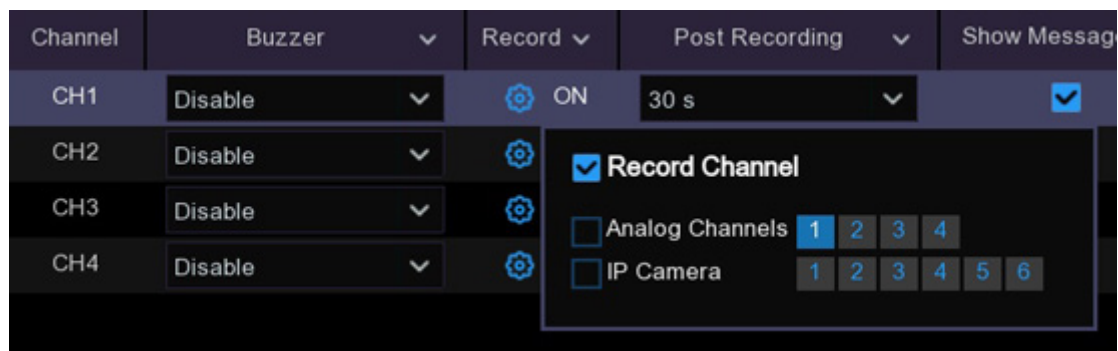

Record Channel: You can set your **DVR** to automatically begin recording on other channels if an alarm is triggered. This function is particularly useful if you have cameras that follow egress paths around your premises or cover blind spots of other cameras as you have a greater chance of capturing an identifying image of the intruder or their vehicle.

To set the other channels that will begin recording when an alarm is triggered on the channel you are setting up, click on the settings button under **Record** and click on the relevant channel/s.

Chapter 7 Record Setup

7.6 Exception Setup

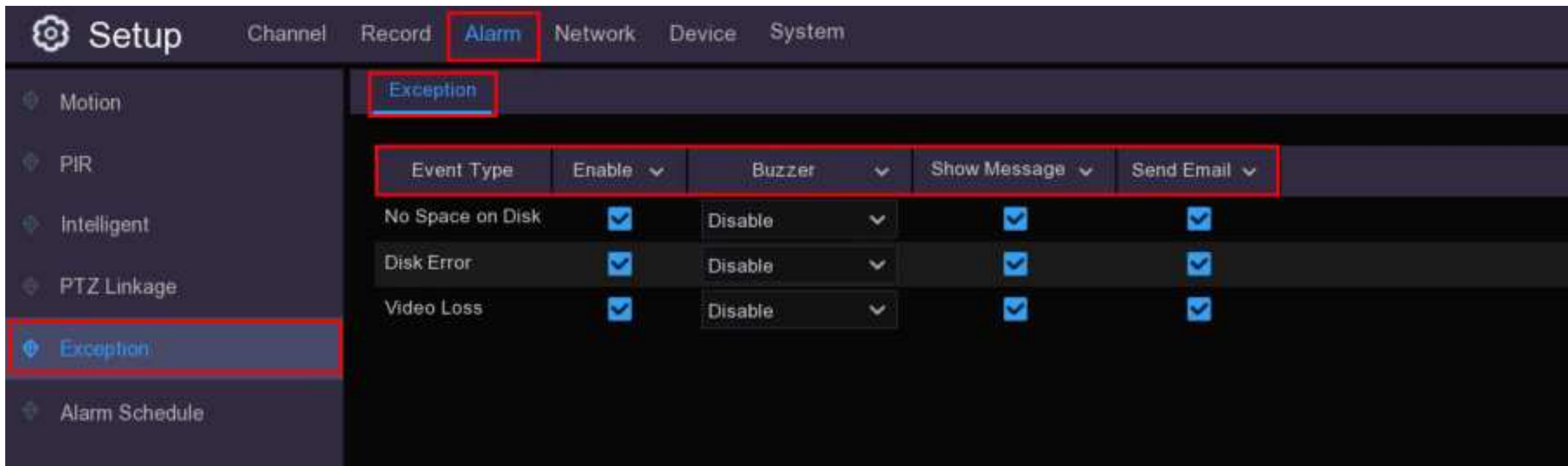

Event Type: Your DVR can be set to alert you if it runs out of HDD space (No Space on Disk), there is an error on the HDD (Disk Error) or if one or more cameras have stopped sending a signal to the DVR (Video Loss).

Enable: It is recommended that you select enable for all the event types.

Buzzer: When enabled an internal DVR audible buzzer will sound every time an exception alarm is triggered.

Show Message: If ticked a message will appear on your live screen monitor.

Send Email: An email will be sent to your nominated email account/s every time an exception alarm is triggered.

Chapter 8 Playback & Search

The Search function gives you the ability to search for and play previously recorded videos as well as snapshots that are stored on your DVR's hard drive. You have the choice of playing video that matches your recording schedule, manual recordings or motion events only. The Backup function gives you the ability to save important events (both video and snapshots) to a USB flash drive or USB Hard drive.

8.1 Using Search Function

Click the Search button  in the Start Menu to enter the search menu.

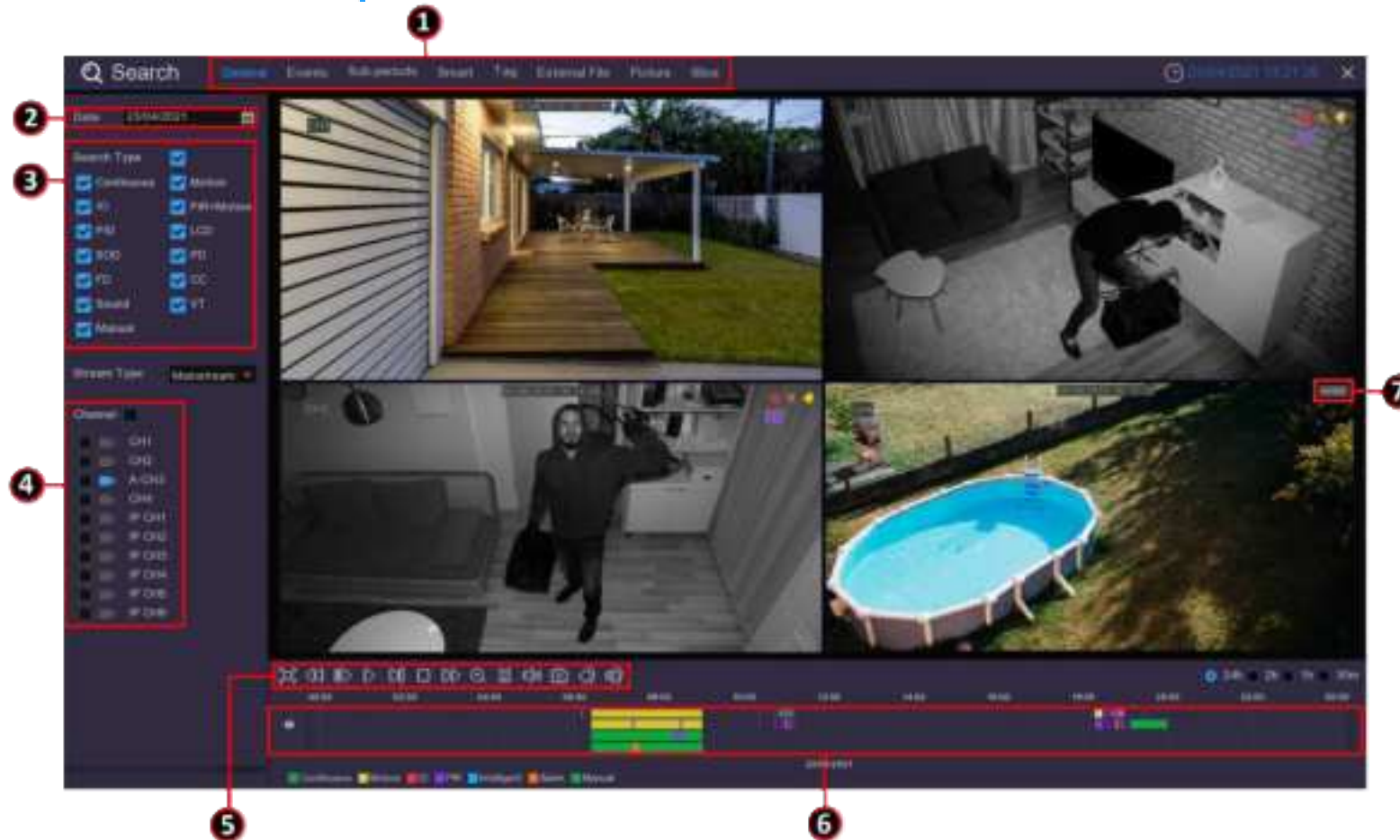













- 1. Search Options:** the system provides various search & playback methods: General, Events, Sub-periods, Smart & Pictures
- 2. Search Date:** search by a date to play back.
- 3. Search Type:** the system provides different search types to narrow your search.
- 4. Channel Selection:** to choose the channels you want to search & play.

Chapter 8 Playback & Search

5. Video Playback Controls: to control the video playback.







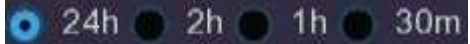

-  Enlarge the video playback to full screen
-  Rewind, x2, x4, x8 and x16
-  Slow Play, 1/2, 1/4 and 1/8, 1/16 speed
-  Play
-  Pause
-  Play frame by frame. Click once to play a frame of the video
-  Stop
-  Fast Forward, x2, x4, x8 and x16
-  Digital Zoom: Click to zoom in then click-and-drag on a camera image during playback to zoom in on the selected area. Right-click to return to regular playback.
-  Video Clip. Quickly save a section of video to a USB flash drive. View more on [8.2.1 Video Clip Backup](#)
-  Save Video Clip.
-  Volume Control: scroll the slider bar to increase or decrease volume.
-  Snapshots: to capture a snapshot image to your external USB data storage. If the video playback is in split-screen view, move the mouse cursor to the channel you want to capture, and then click the icon to save the snapshot.

Chapter 8 Playback & Search

6. **Timeline:** Recordings are shown with coloured bars to represent different types of recording (legend shown in the bottom-right corner of the display). Use the timeframe  options to view a smaller or larger time period.

Different types of recording shown in different colours:

-  Continuous recording
-  Motion detection
-  IO (Smart)
-  PIR detection
-  Intelligent
-  Alarm (Combined Motion detection and PIR)
-  Manual

7. **Playback Status:** displays how the video is playing, normal speed, paused or fast forward etc.

Chapter 8 Playback & Search

8.2 Search & Play Video in the General Menu

This menu gives you options to search & play recordings for a selected date.

1. Select a date to search for video recordings from the calendar. A red line on the date indicates there are recordings available. **2**

2. Choose a search type. **3**

3. Select the channels you would like to search, or check Channel to search all connected channels. **4**

4. The search result will display on the timeline from 00:00 to 24:00. **6**

5. Click play button  to start playback.

6. Control the playback with the buttons on the Video Playback Controls. **5**

7. Use the time frame options  to view a smaller or larger time frame.

8. If you want to quickly save a section of video during playing back to a USB flash drive, use the Video Clip backup function. 

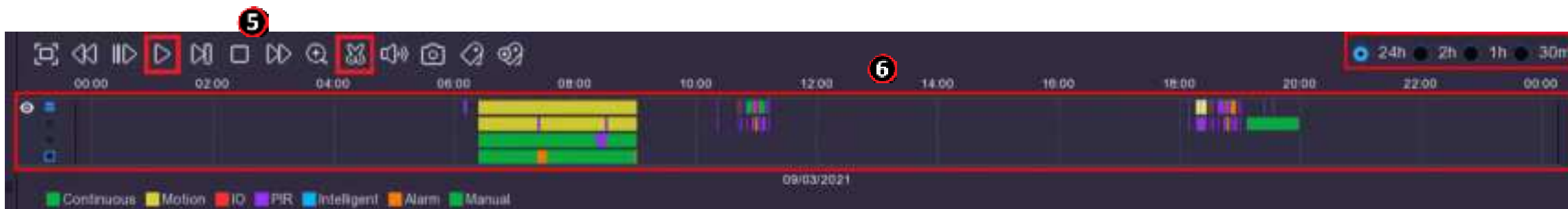
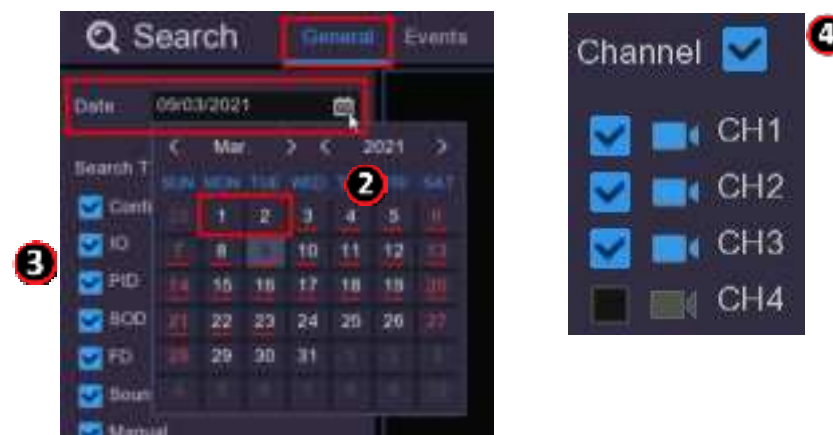

Chapter 8 Playback & Search

8.2.1 Video Clip Backup

1. Insert your external USB drive to the DVR.
2. Start a video recording playback.
3. Click  icon.
4. Check the channel(s) you want to use to make video clip backups.

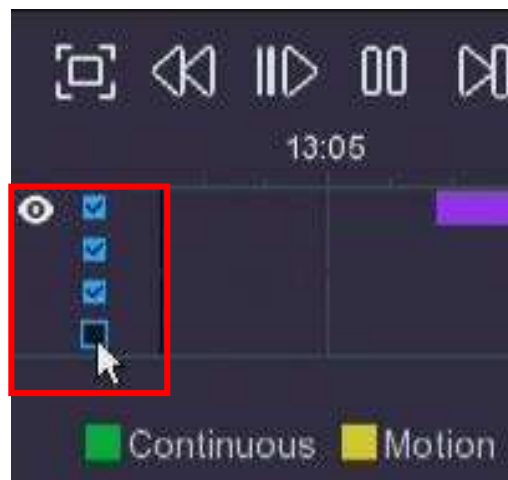

5. Move the mouse cursor to the timeline where you want to start the video clip.

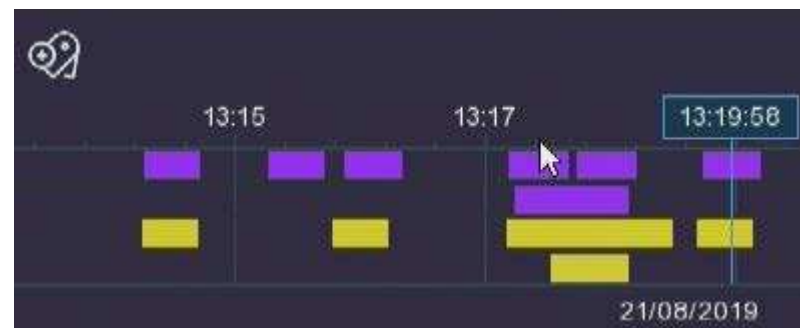

6. Press and hold the left button of your mouse, and drag the cursor to the timeline where you want to end the video clip.

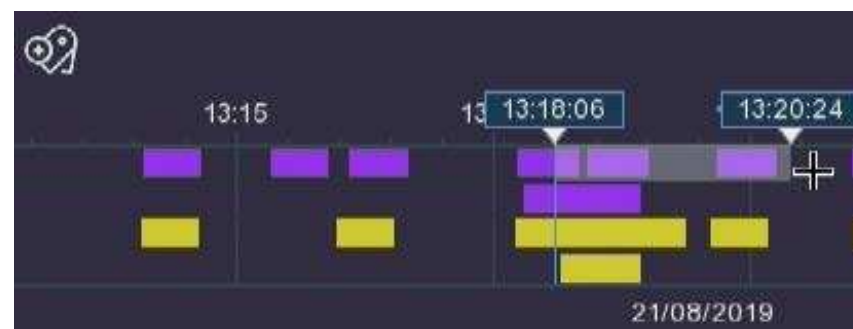

Chapter 8 Playback & Search

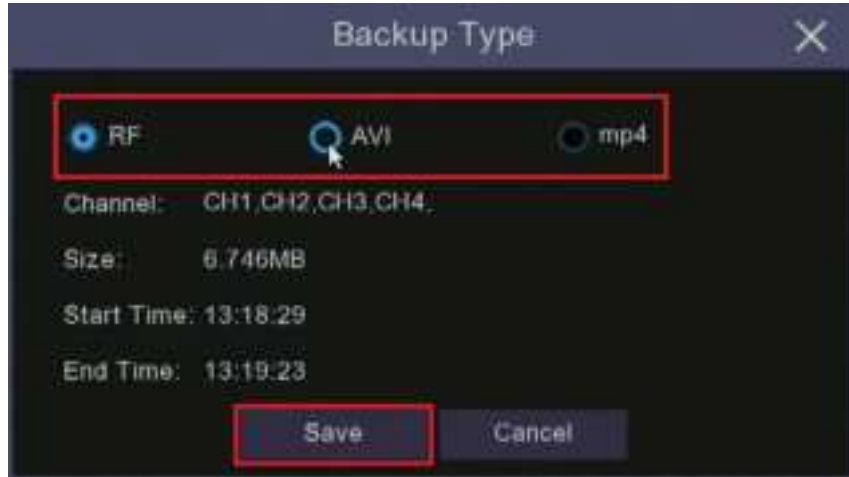

7. When you have finished selecting the recordings you want to back up the Video Clip icon will change to the Save Video Clip icon , clicking on this icon will bring up the Backup Type window. Select a file type for your backup files, when you click the Save button the Backup window will open.

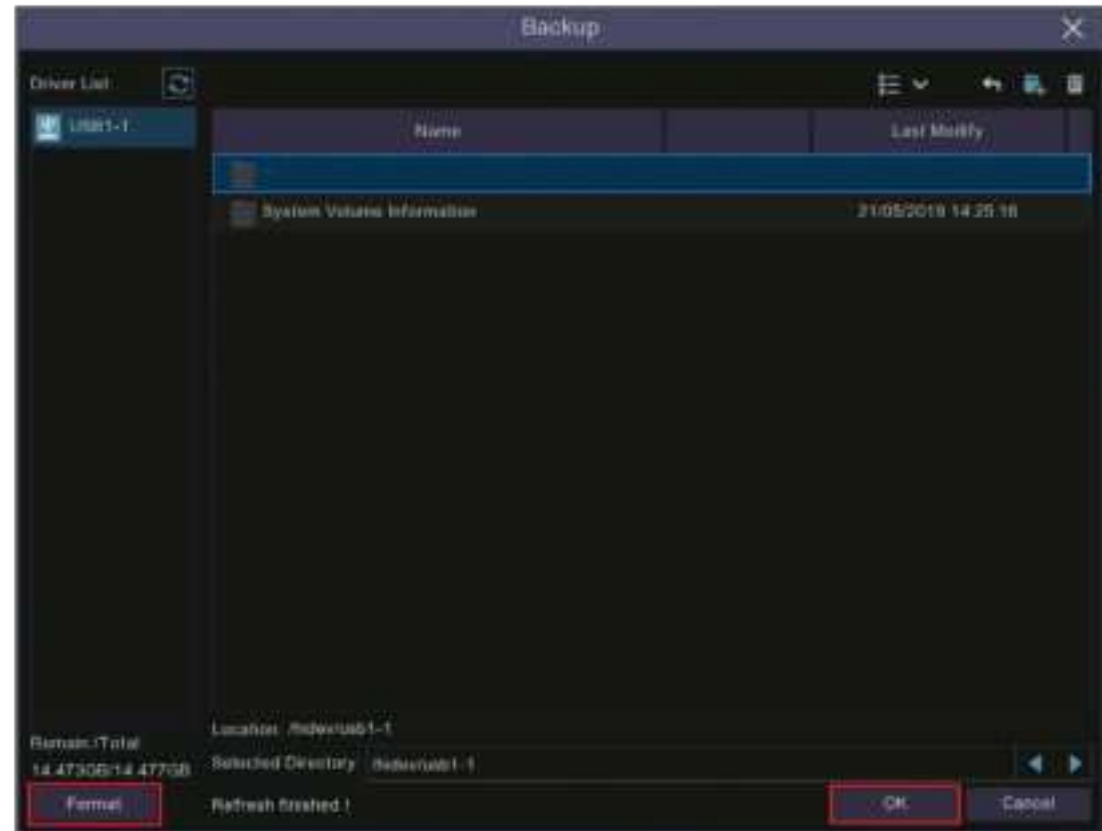

8. If you are unsure whether your USB storage is correctly formatted click the Format button. Check the directory to make sure the video is being saved to the correct location and click OK. The system will automatically assign file names to your video clips.

Chapter 8 Playback & Search

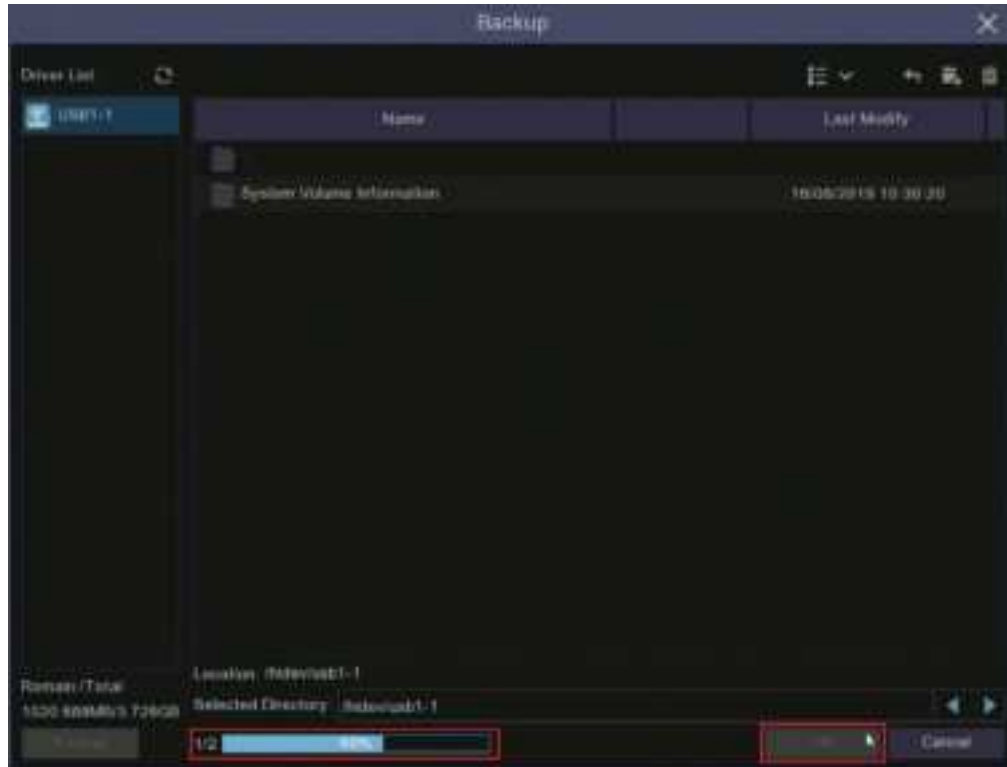

9. After clicking OK a progress bar will appear showing the number of files uploaded and the total progress.

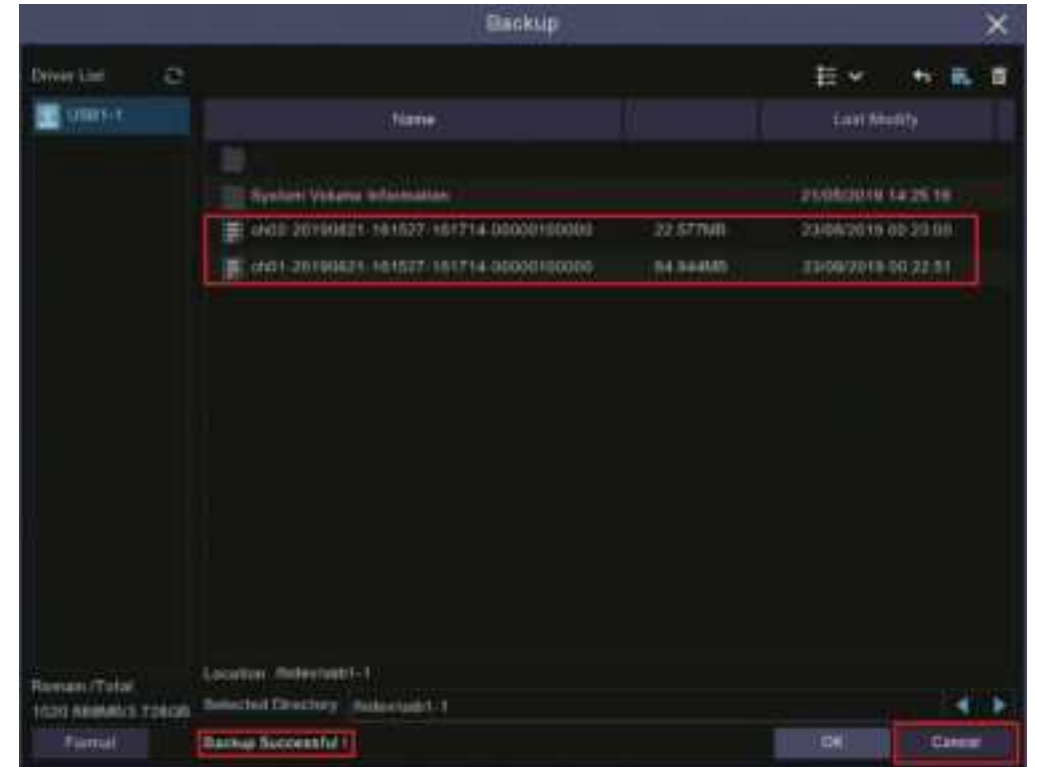



10. Once the files have been uploaded to your USB the progress bar will be replaced by the message "Backup Successful". You can now close the Backup window by clicking Cancel.

Chapter 8 Playback & Search

8.2.2 Event Search, Playback & Backup

Event search lets you view a list of video recordings with the channel, start and end time, and recording type conveniently summarised. You can also quickly back up events to an external USB thumb drive or HDD.

1. Choose the date and time you want to search.
2. Select the recording types you want to search, you can tick **Search Type** to choose all.
3. Choose the channels you want to search, or check **Channel** to choose all channels. Channels with available recordings will have  next to it, if the camera is greyed out there is no recording.
4. Click the  icon to start a search.
5. Events fitting your search criteria are displayed in list form. Double click on a tile to watch that recording.

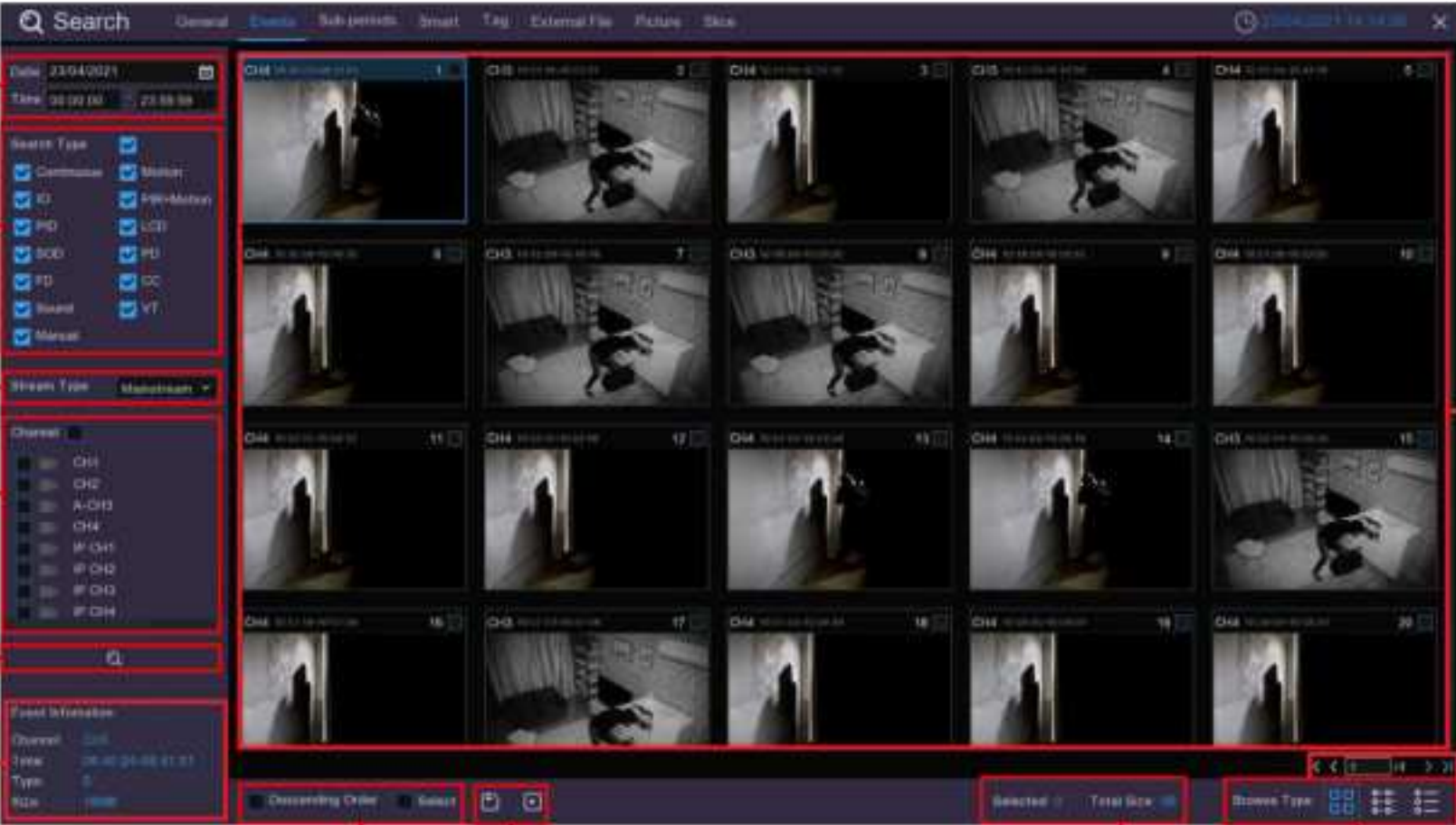

The screenshot shows the event search interface with the following numbered callouts:

- 1**: Date and time selection fields.
- 2**: Search Type selection area with checkboxes for various recording types.
- 3**: Channel selection list.
- 4**: Search button (magnifying glass icon).
- 5**: Grid of video thumbnails for selected channels.
- 6**: Playback controls at the bottom right of the grid.
- 7**: Playback controls at the bottom right of the grid.
- 8**: Event information panel on the left side.
- 9**: Sorting options (Descending Order, Select).
- 10**: Selected and Total Size information.
- 11**: Playback controls at the bottom left of the grid.
- 12**: Stream Type dropdown menu.

Chapter 8 Playback & Search

6. Click the  icons in the bottom-right corner of the menu to browse between pages of events, or input the page you want to browse.
7. You can switch the view of list form by clicking below the icons which are shown at the bottom right corner of the screen:



















Thumbnail view. Shows large snapshots of the events with 20 thumbnail images per page. This is the default view as shown on the previous page.





List view. Recorded events will be displayed in a list with the channel and the time as below.









































General	Events	Sub-periods	Smart	Tag	External File	Picture	Slice												
	1	CH3	09:01:28		2	CH3	10:21:14		3	CH3	10:31:08		4	CH3	10:34:04		5	CH3	10:38:54
	6	CH3	10:40:10		7	CH3	10:43:19		8	CH3	10:43:47		9	CH3	10:44:07		10	CH4	10:44:07
	11	CH4	10:46:37		12	CH4	10:47:27		13	CH3	10:48:31		14	CH3	10:49:37		15	CH4	10:50:01
	16	CH3	10:51:59		17	CH3	10:53:57		18	CH3	10:54:07		19	CH3	10:55:11				

Chapter 8 Playback & Search



Detailed view. In this view the Events will be listed lineally and include the date, start time, end time, file size and a playback button. In this view you can lock the video events to keep events from being overwritten in the hard drive. The  icon indicates the file is unlocked, if you click on this icon it will change to the locked icon  and the file will be locked from erasure.

	Channel	Type	Date	Start Time	End Time	Size	Playback	Lock
1	CH3	P	27/08/2019	09:01:28	09:02:02	27MB		
2	CH3	P	27/08/2019	10:21:14	10:21:50	27MB		
3	CH3	F	27/08/2019	10:31:08	10:31:44	20MB		
4	CH3	P	27/08/2019	10:34:04	10:34:40	20MB		
5	CH3	F	27/08/2019	10:38:54	10:39:30	20MB		
6	CH3	P	27/08/2019	10:40:10	10:40:47	20MB		
7	CH3	F	27/08/2019	10:43:19	10:43:47	21MB		
8	CH3	P	27/08/2019	10:43:47	10:43:55	0MB		
9	CH3	P	27/08/2019	10:44:07	10:44:43	27MB		
10	CH4	F	27/08/2019	10:44:07	10:46:24	61MB		
11	CH4	F	27/08/2019	10:46:37	10:47:11	16MB		
12	CH4	P	27/08/2019	10:47:27	10:49:24	52MB		
13	CH3	F	27/08/2019	10:48:31	10:49:35	49MB		
14	CH3	P	27/08/2019	10:49:37	10:51:16	74MB		
15	CH4	F	27/08/2019	10:50:01	10:50:51	23MB		
16	CH3	F	27/08/2019	10:51:59	10:53:55	80MB		
17	CH3	P	27/08/2019	10:53:57	10:54:07	9MB		
18	CH3	F	27/08/2019	10:54:07	10:54:59	40MB		
19	CH3	F	27/08/2019	10:55:11	10:56:27	57MB		

Chapter 8 Playback & Search

8. When you click the left button of your mouse on one of the events, the system will show the **Event Information** on the left bottom corner of the screen.



9. In order to export your recorded videos to an external storage device such as a USB thumb drive, check the box next to the number of the event to select individual files, or check the box next to **Select** to select all events in the page.

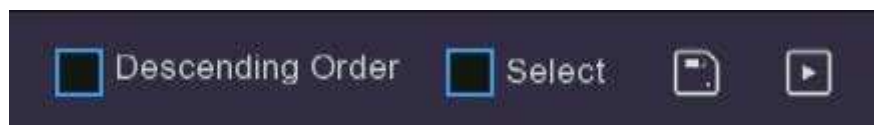

If you tick the **Descending Order** box the list will change order from earliest to latest video to latest to earliest event.

10. The number of selected files, total size information will be displayed at the right bottom of the screen.

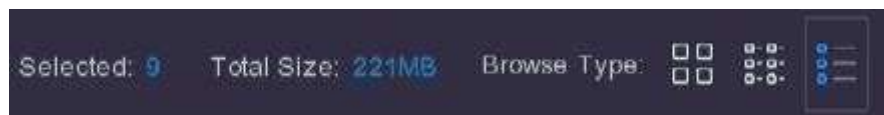

11. After selecting the file, click the  icon to save the video to USB drive or click the  icon to play the event in a separate playback control window.

12. You can choose to select Mainstream or Substream videos, this may help you if your storage device has low capacity.

Chapter 8 Playback & Search

8.2.3 Sub-periods Playback

Sub-periods playback allows you to play multiple normal recordings and motion events simultaneously from a single channel. With normal and event recordings, the video is divided evenly depending on the split-screen mode that has been selected. For example, if the video is an hour long and you have selected Split-screens x 4, each split-screen will play for 15 minutes.



1. Choose the date & time you want to search.
2. Choose the split-screens you want the videos to be played in.
3. Check the recording types you want to search, or check Search Type to choose all.
4. Choose the channels you want to search. Please note that this function only supports search & play one channel at a time.
5. Click the play button to start playing. Control the playback with buttons on Video Playback Controls.
6. Videos are being played in split-screens.

Chapter 8 Playback & Search

7. Click the left button of your mouse upon a particular split-screen, the time period of the video split-screen will be displayed on the timeline. The color bar on the top of the timeline indicates the time span of the video split-screen you have clicked. The color bar on the bottom of the timeline indicates the time span for the whole videos you have searched.
8. Use the timeframe options  to view a smaller or larger time period.

Chapter 8 Playback & Search

8.3 Tag Search and View

A simple way of saving videos to view or download later is to use tags to identify these recordings. This is a handy tool if you have a lot of stored recordings but you are only interested in downloading videos that contain particular content.

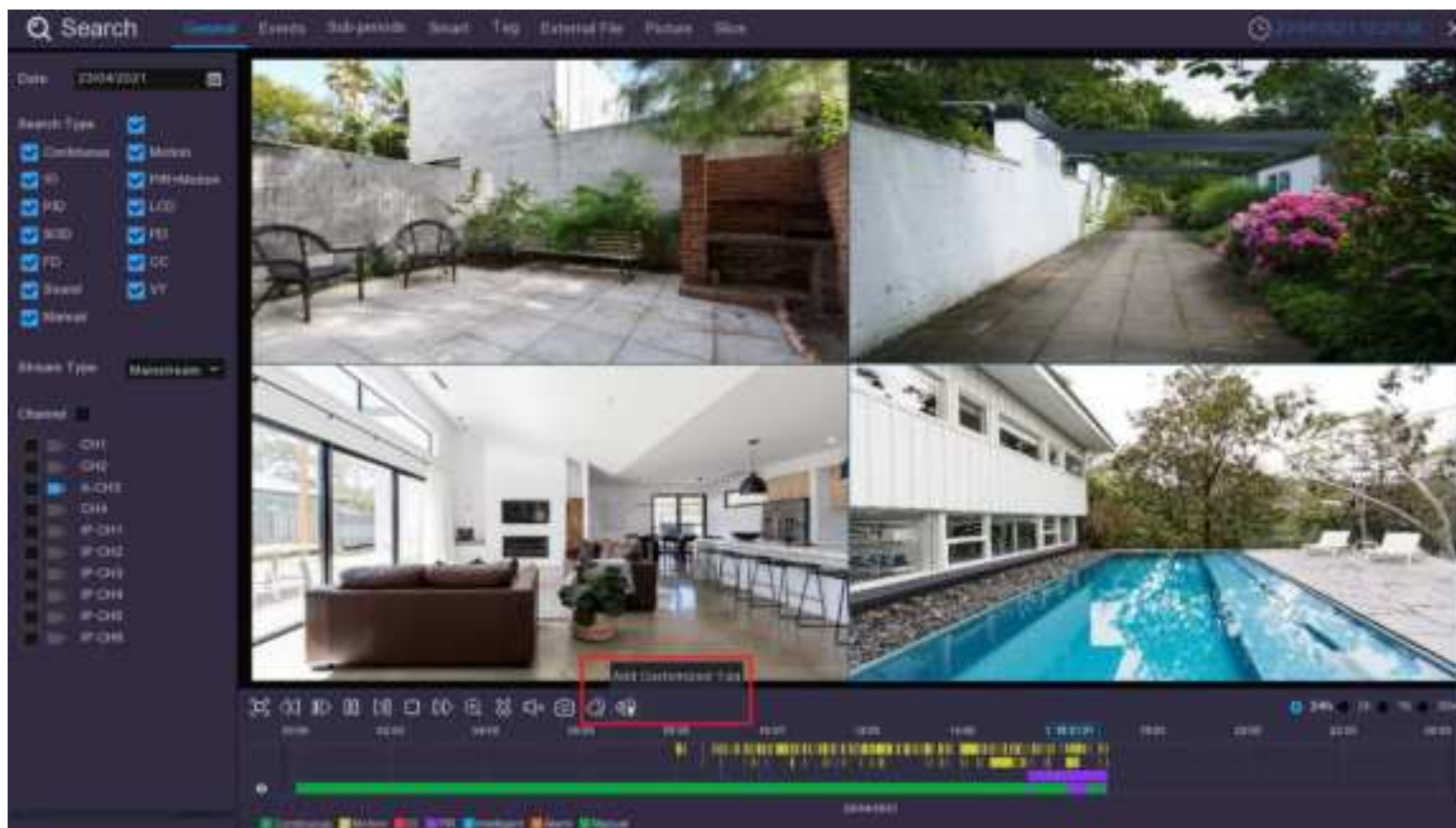

1. While in the Search General view, click on the recording you want to tag in the timeline.

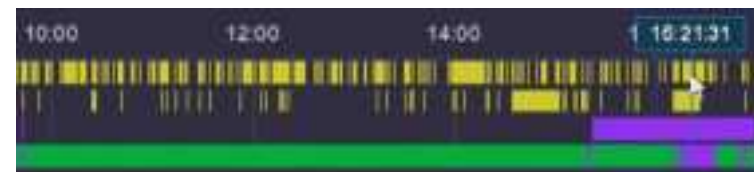

Then either click:

 **Add Default Tag**

Or

 **Add Customized Tag**

2. A **Default Tag** will save with a default file name of Tag, Tag1, Tag2 etc.

3. A **Customized Tag** will allow you to create an individual name for the tag to make it easier to identify in the Tag menu.

Chapter 8 Playback & Search

8.3 Tag Search and View

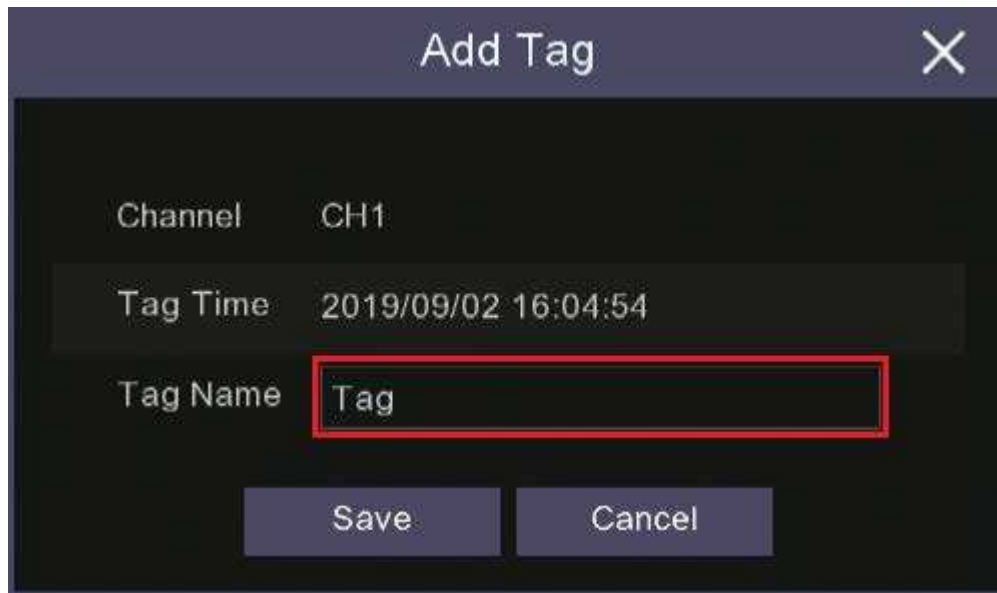

4. If you choose to create a **Customized Tag** this window will pop up, if you click in the **Tag Name** box and the keyboard will appear to let give the Tag a name.

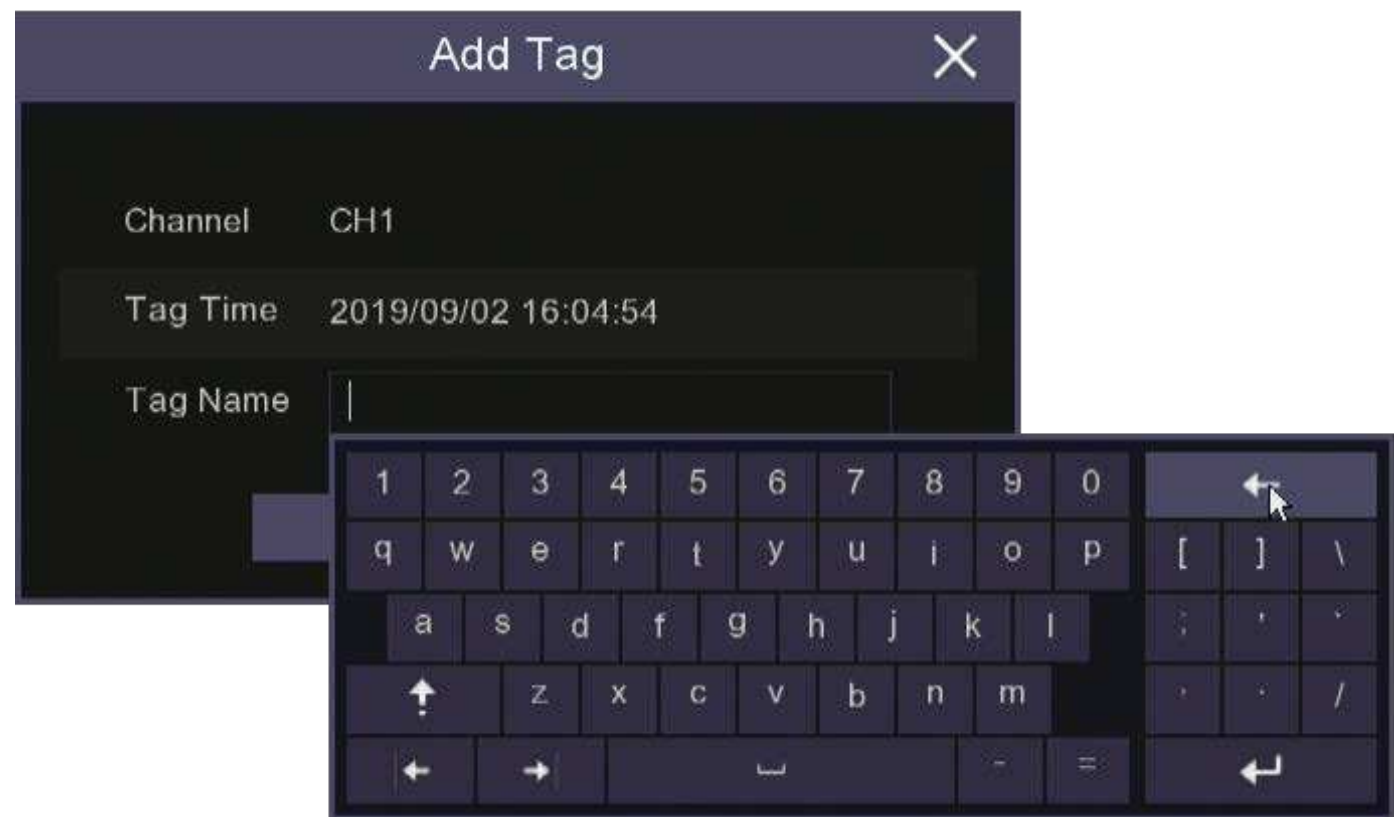

5. Use the keyboard backspace button to clear the space then you can start writing in the name you want use.

Chapter 8 Playback & Search

8.3 Tag Search and View

6. When you have finished typing the file name click on the **Enter** button and then click **Save** on the next window. Your Tag is now saved under the date and channel that appeared in the Add Tag window.

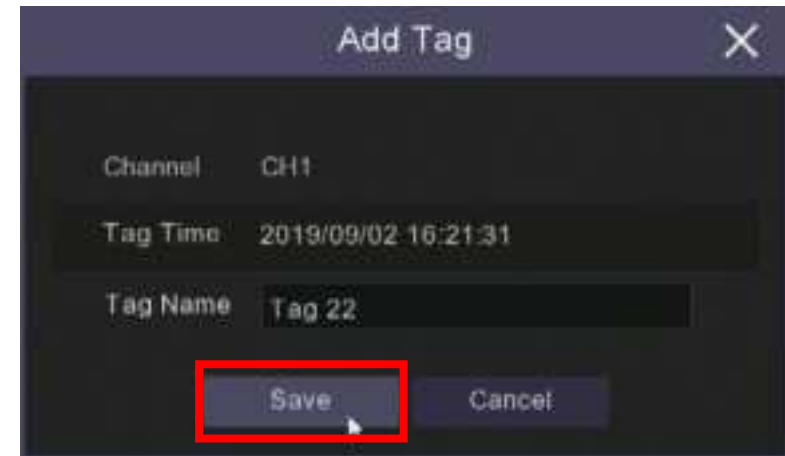
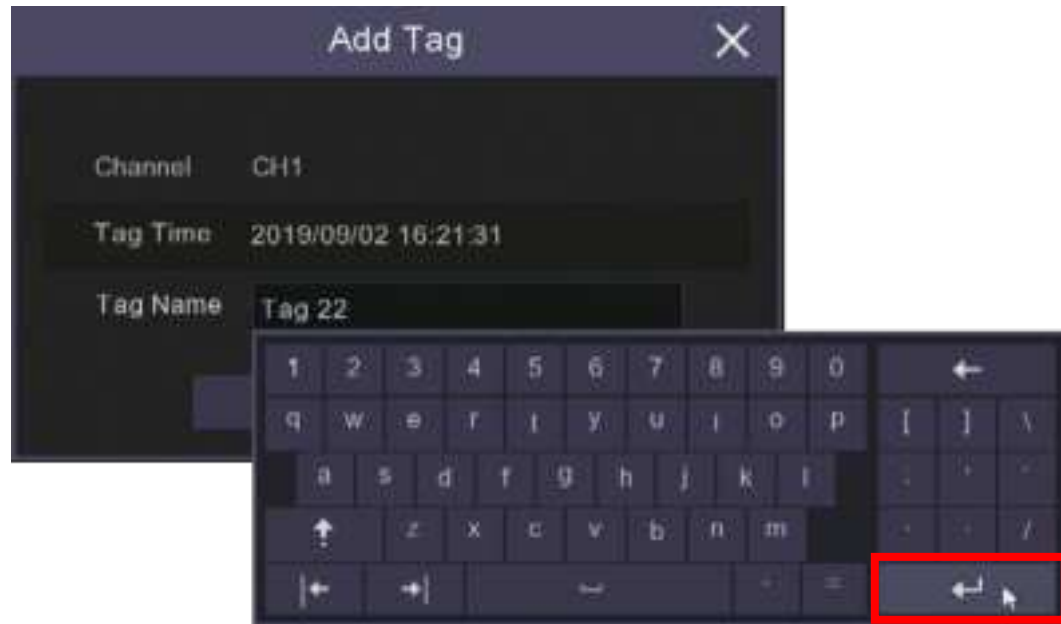

Chapter 8 Playback & Search

8.3 Tag Search and View

7. To view your tagged recordings first the **Tag** sub-menu in the **Search** menu.

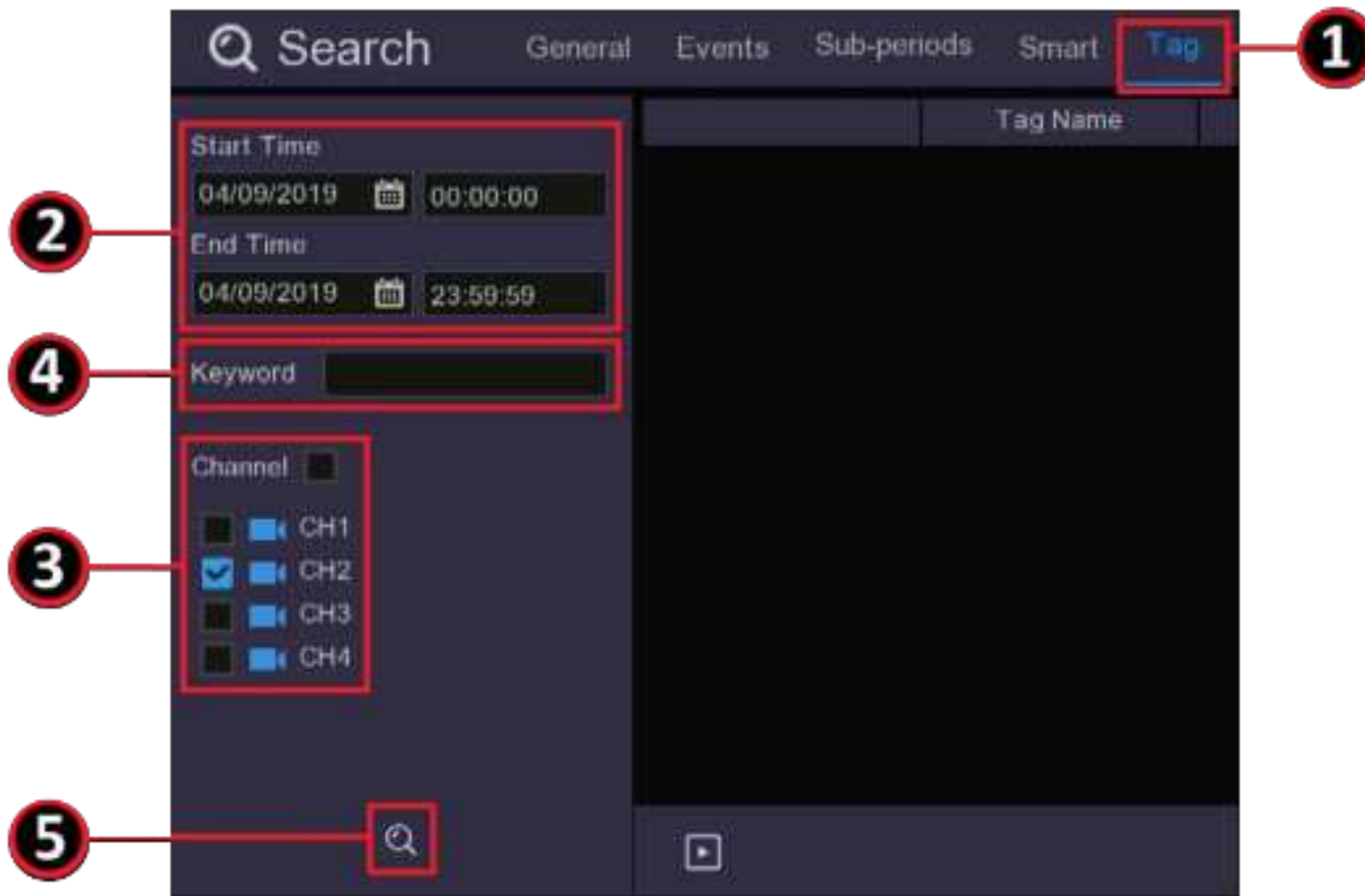



1. Click **Tag**.
2. Select the date or date range you wish to search for **Tags**.
3. Select the **Channels** you wish to search.
4. You can also search by **Keyword**, this is useful if you have a lot of tags and you only want to find those that have a specific name.
5. Click the search icon  and your results will appear on the right hand side of the screen.

Chapter 8 Playback & Search

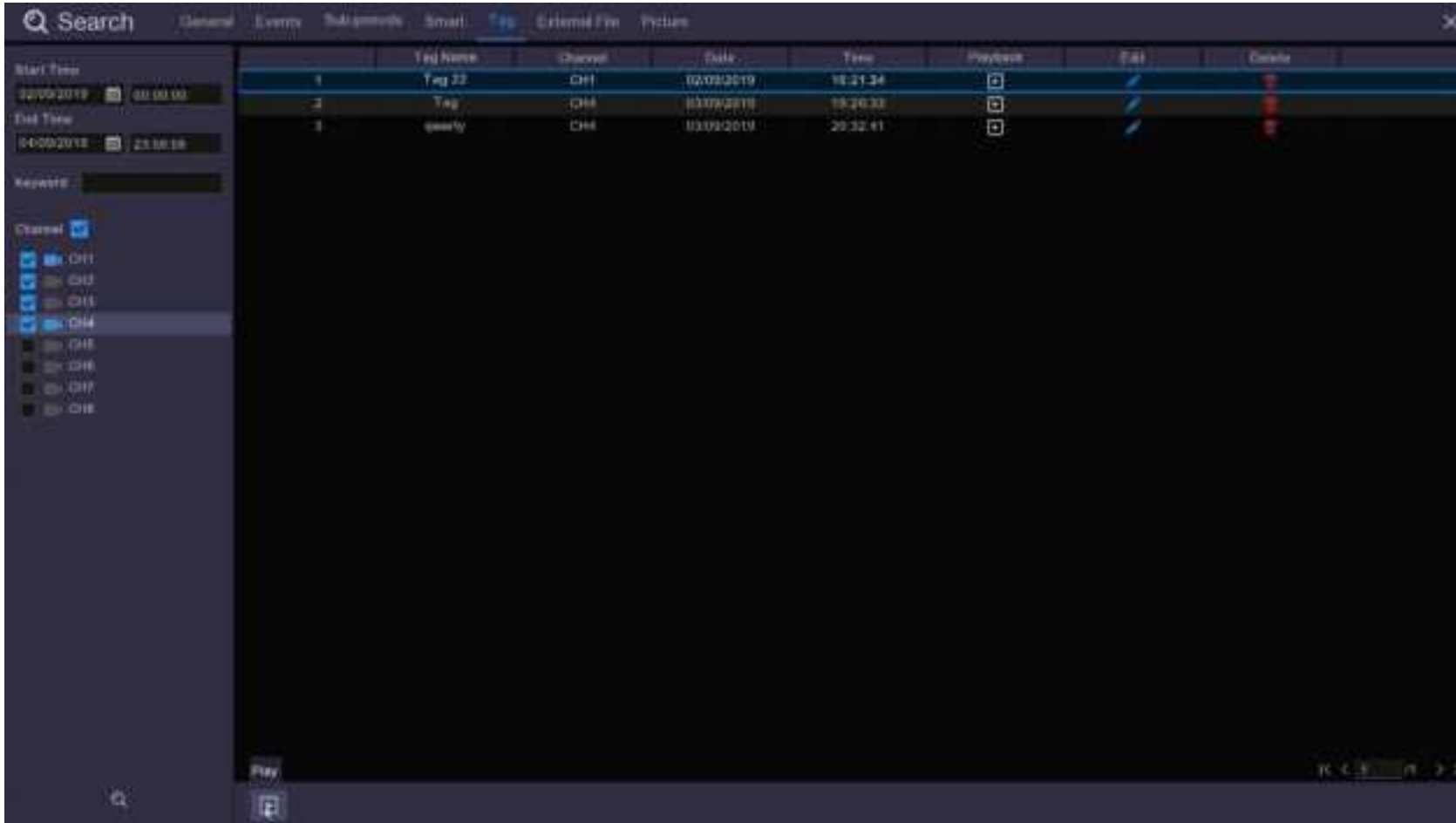
8.3 Tag Search and View



From here you can select the videos you wish to view by clicking **Play** at the bottom of the screen to play all videos in sequence or click the **Playback** button  on the line containing the **Tag** you wish to view.

If you want to change the name of the **Tag** you do this by clicking on the  symbol.

You can also choose to delete **Tags** from this menu by clicking on the  symbol. Deleting the **Tag** does not delete the recording on the **Tag** you have used to identify the recording.

When you **Play** a tagged video it will open in a larger screen.

Chapter 8 Playback & Search

8.3 Tag Search and View

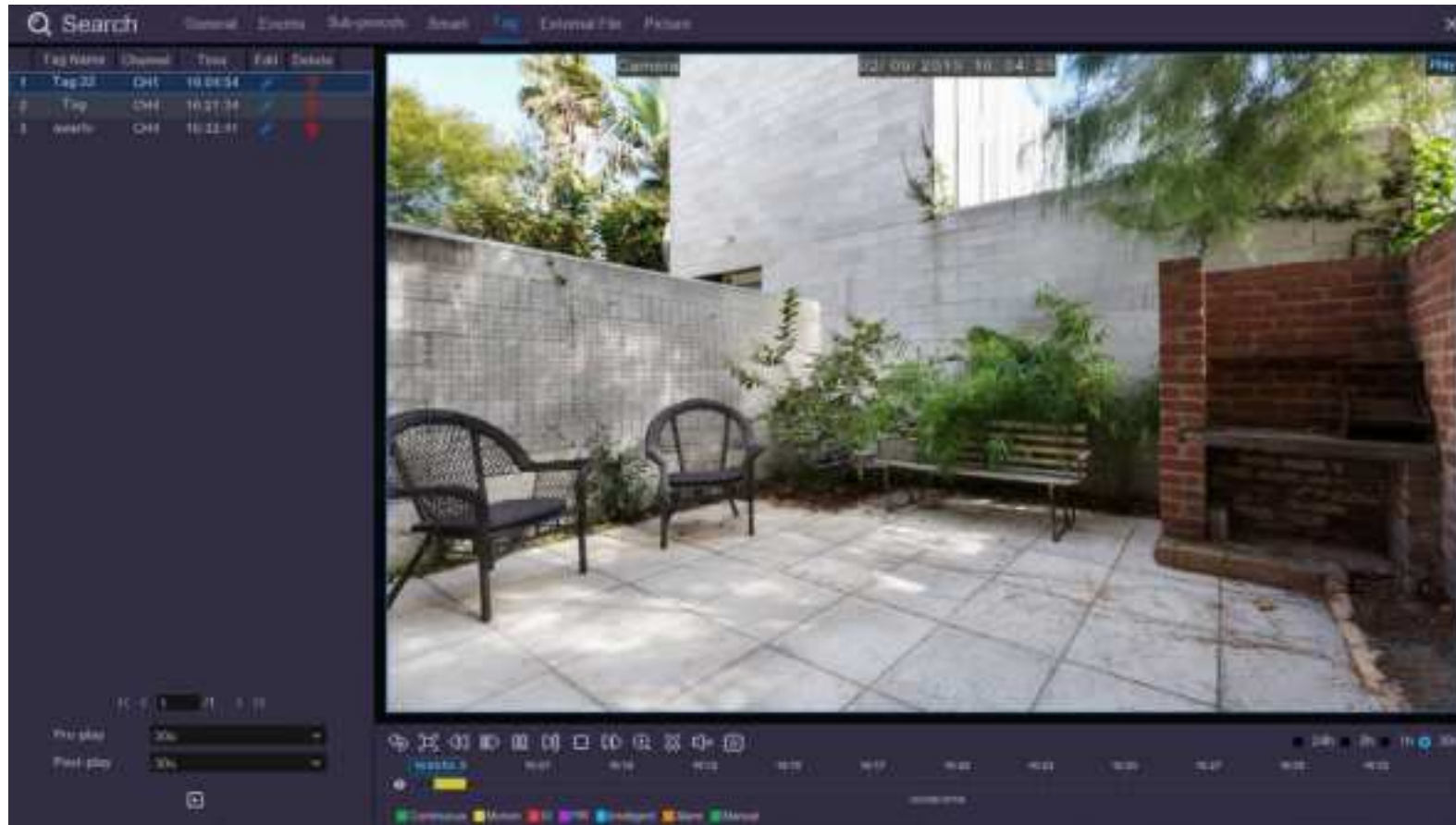

From the **Tag** menu you have all the functions available in the **General** search menu including **Zoom** and **Save** to a USB device.

The difference to the **General Playback** menu is in the **Tag** menu you will only see those videos you have tagged.

Chapter 9 Network Setup

9.1 General

This menu allows you to configure network parameters, using **DHCP** or **PPPoE**. Your home network type is most likely DHCP, in this case simply ensure DHCP box is ticked and the system will set itself up.

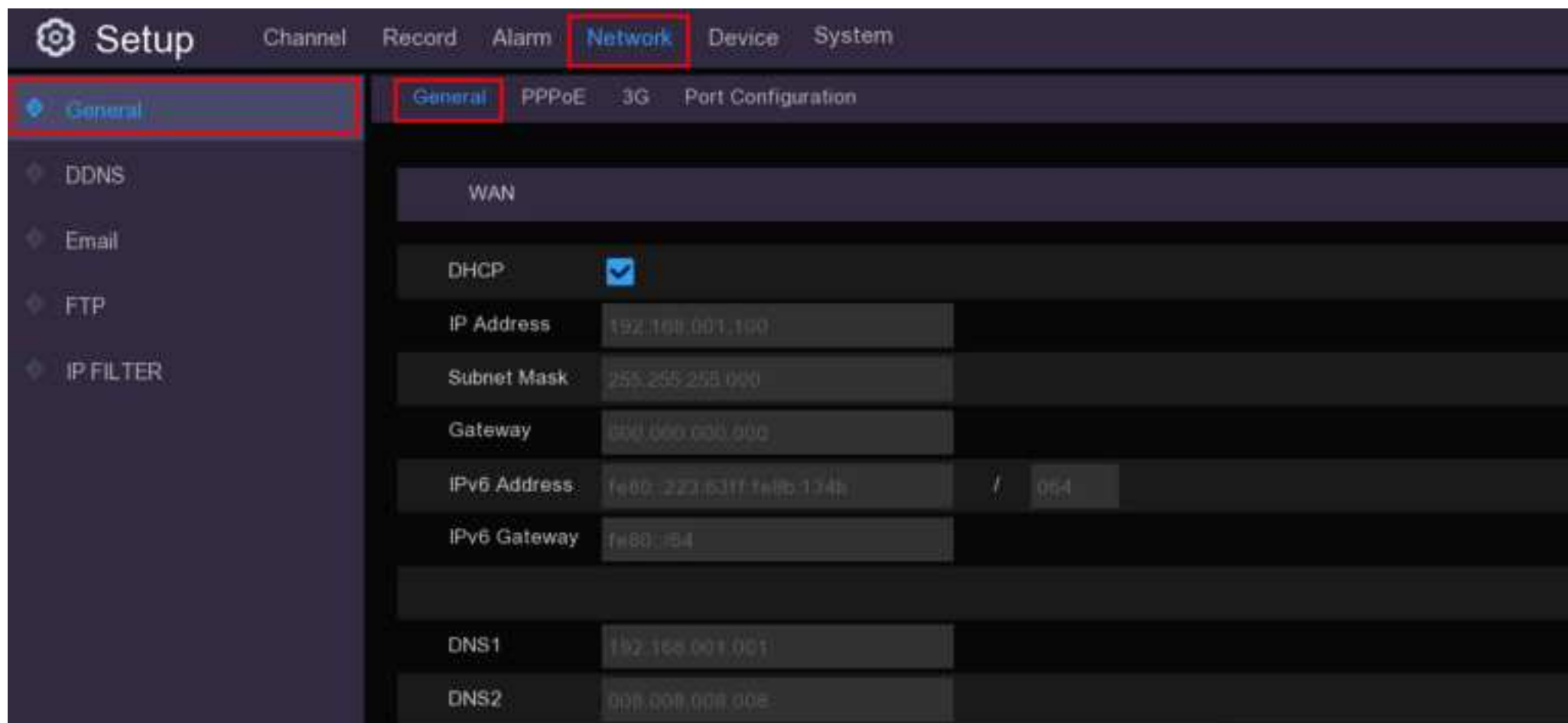

Chapter 9 Network Setup

9.1.1 General - PPPoE

If your network is manually addressed you need to choose PPPoE and you will need your network authentication user name and password to the Internet.

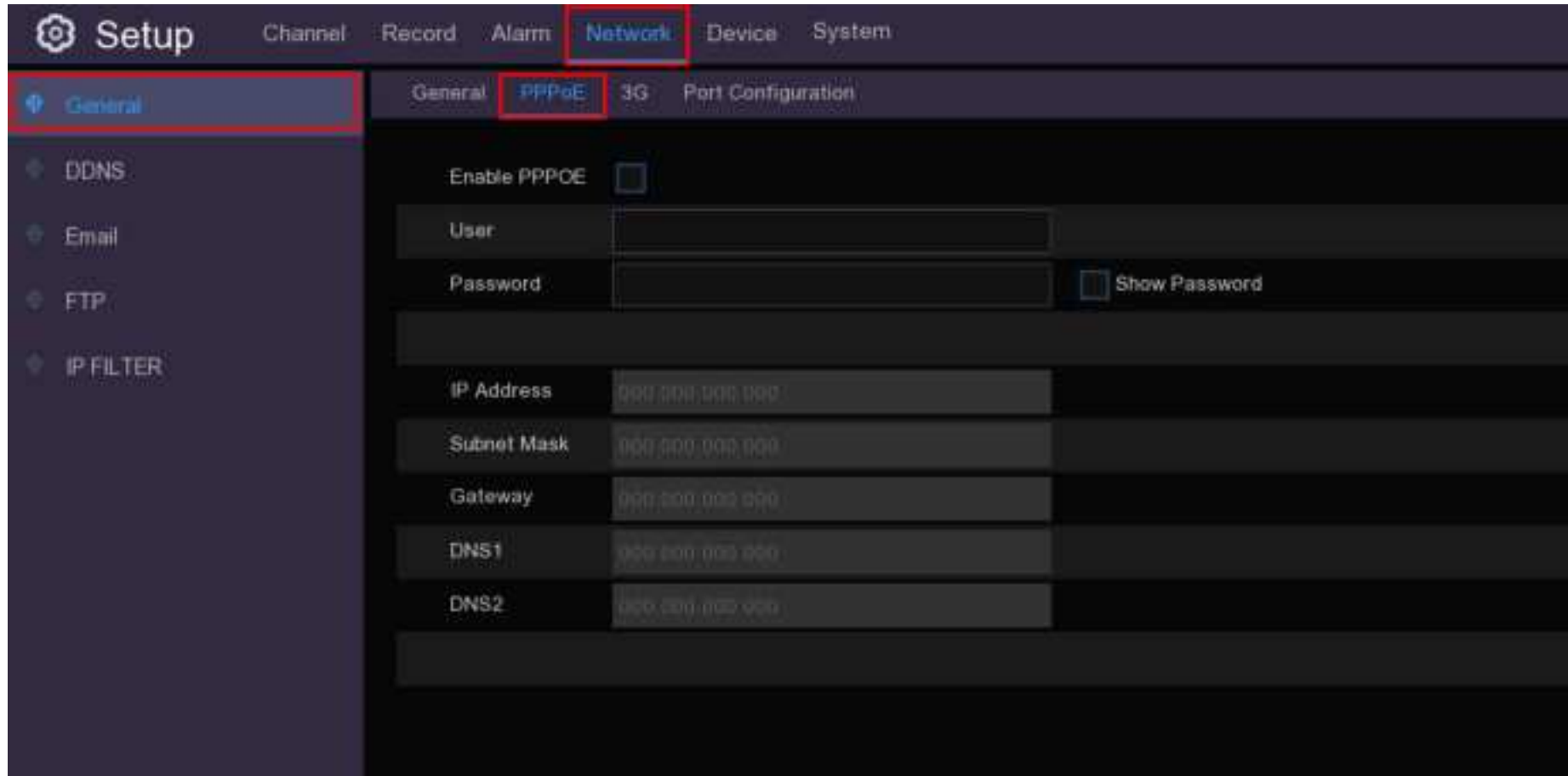

The screenshot displays the 'Setup' interface for network configuration. The 'Network' tab is selected, and the 'PPPoE' sub-tab is active. The 'General' sub-tab is also highlighted in the left sidebar. The main configuration area includes the following fields:

- Enable PPPOE:** A checkbox that is currently unchecked.
- User:** A text input field.
- Password:** A text input field with a 'Show Password' checkbox to its right.
- IP Address:** A text input field with a placeholder value of '000.000.000.000'.
- Subnet Mask:** A text input field with a placeholder value of '000.000.000.000'.
- Gateway:** A text input field with a placeholder value of '000.000.000.000'.
- DNS1:** A text input field with a placeholder value of '000.000.000.000'.
- DNS2:** A text input field with a placeholder value of '000.000.000.000'.

Chapter 9 Network Setup

9.1.2 General – Port Configuration

Web Port: This is the port that you will use to log in remotely to the DVR when using the **Web Client**. If the default port 80 is already taken by other applications, please change it.

Client Port: This is the port that the DVR will use to send information through. If the default port 9000 is already taken by other applications, please change it.

RTSP Port: Default is 554, if the default port 554 is already taken by other applications, please change it.

UPnP: If you want to log in remotely to the DVR using the Web Client, you need to complete the port forwarding. Enable this option if your router supports the UPnP. You need to enable UPnP both, on DVR and router, this will need to be done manually. If your router does not support UPnP, make sure the port forwarding is completed manually.

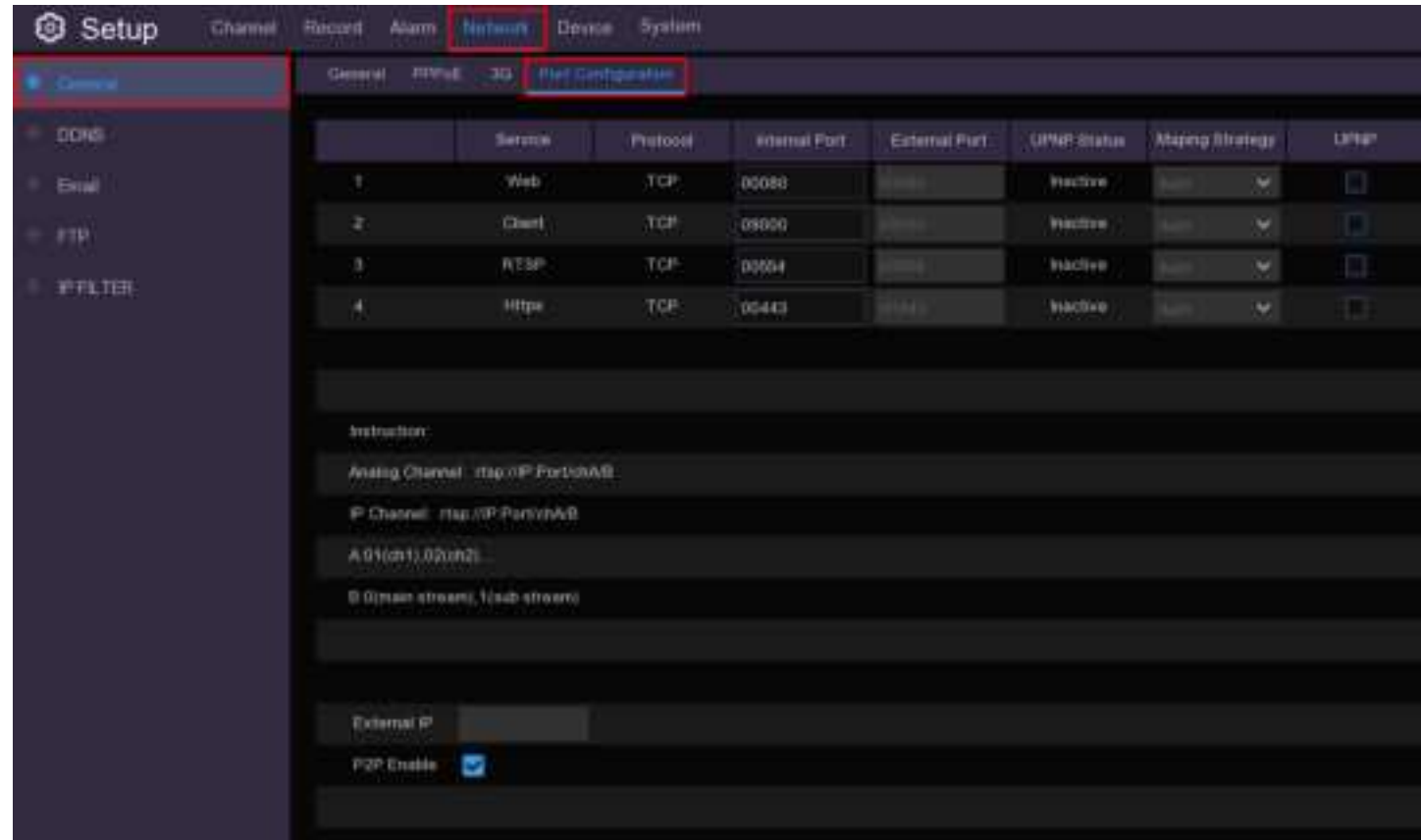

Chapter 9 Network Setup

9.2 DDNS

With current internet systems it is highly unlikely that you will need to use DDNS because we use a peer-to-peer technology, however there may be some unusual circumstances that will require the use of DDNS. DDNS provides a static address to simplify remote connection to your DVR and menu allows you to configure these settings. To use the DDNS, you first need to open an account on a DDNS service provider's web page.

DDNS: Check to enable DDNS.

Server: Select the preferred DDNS server. Your system will work with these well known DDNS providers: *DDNS_3322*, *DYNDNS*, *NO_IP*, *CHANGEIP*, *DNSEXIT*.

Domain: Enter the domain name you created on the DDNS service provider's web page. This will be the address you type in the URL box when you want to connect remotely to the WIRELESS NVR via PC. For example: *NVR.no-ip.org*.

User/Password: Enter the user name and password you obtained when creating an account on the DDNS service provider's web page.

After all parameters are entered, click **Test DDNS** to test the DDNS settings. If the test result is "Network is unreachable or DNS is incorrect", please check whether the network works fine, or the DDNS information is correct or not.

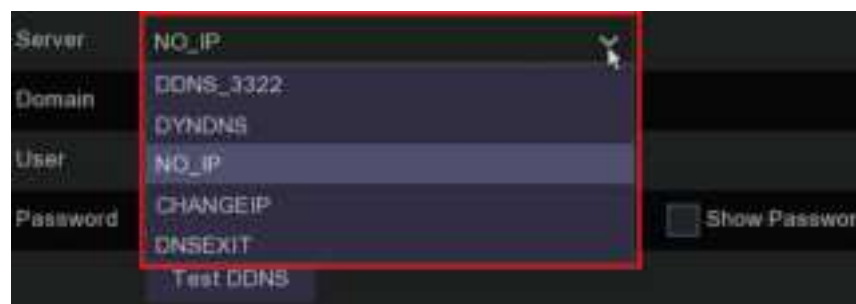
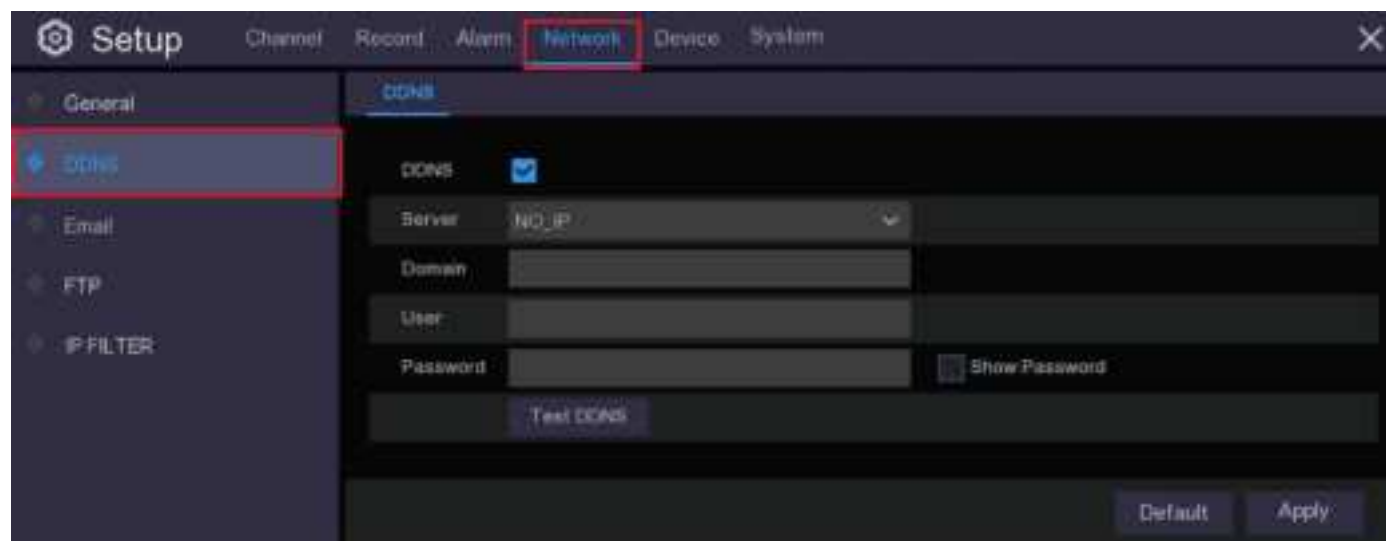

Chapter 9 Network Setup

9.3 Email

To use the email notification you need to set up your device with an email account to use when sending alerts, this can be any email address you currently use or you could use one you specifically set up for your recorder to use. If you wish to use the Cloud Storage function of your DVR you will need use the email address you use for your **Dropbox** or **Google Drive** accounts as these are the two cloud services that are recognised by your DVR. Details on how to setup cloud storage are in section **10.3** of this manual, **Setup > Device > Cloud**.

You then need to nominate the email address or addresses of up to three receivers to whom you wish to send alarm email notifications.

If you forget your password, the nominated email addresses can be used to reset the master password for the DVR. If this is not completed, you will need to contact Concord Support for assistance.

In order to set your device up to send emails you will need to know the **Outgoing SMTP Port** and **Outgoing SMTP Server** for your particular email provider, also check what your email user name is, it is usually just your email address but with some providers it can be an alternative name. You can usually find this information on your provider's website.

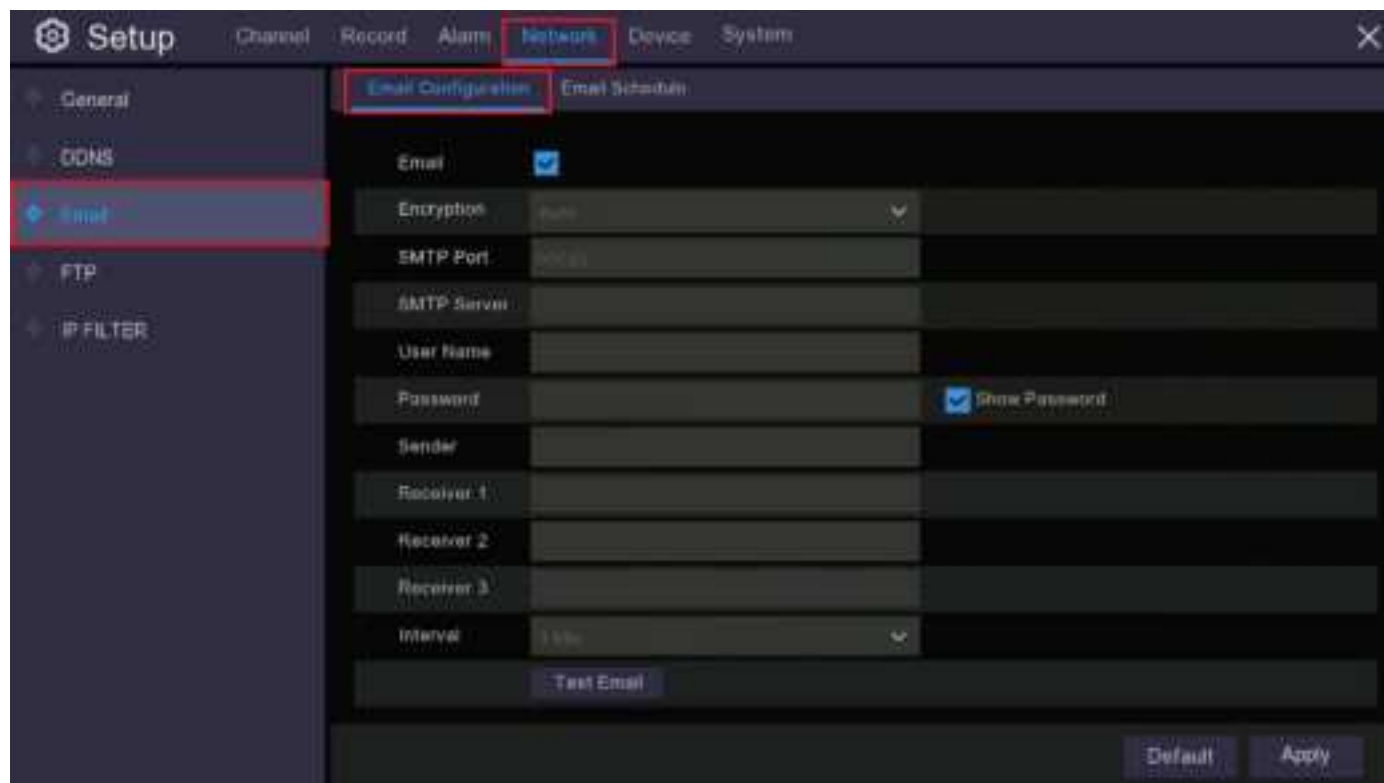

Chapter 9 Network Setup

9.3 Email

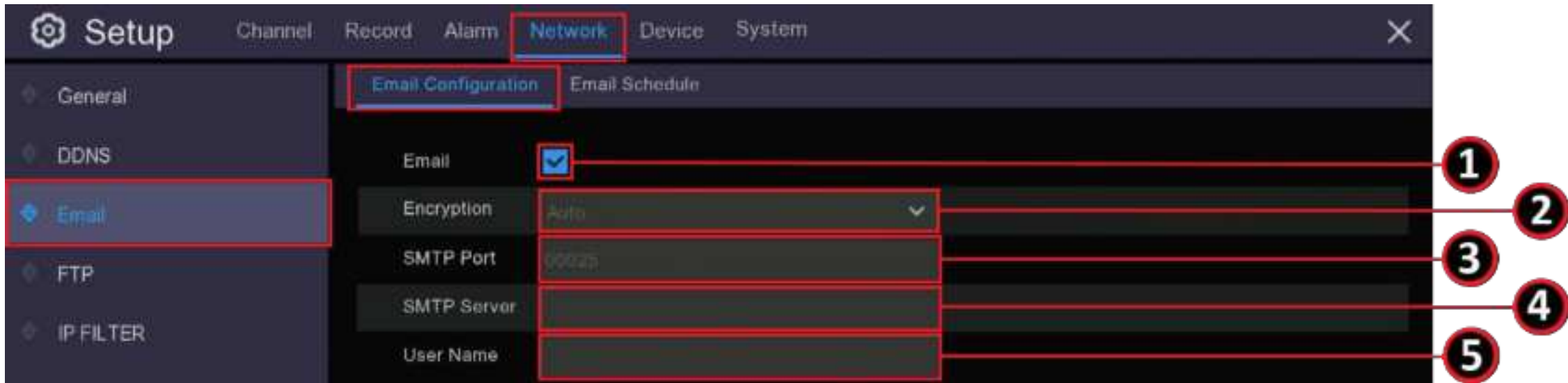

1. **Email:** Click "Enable" to input your email details and activate email alerts.
2. **Encryption:** It is advisable to leave this on "Auto". However in some circumstances it may be necessary if your email server requires the SSL or TLS verification to select one of these here.
3. **Outgoing SMTP Port:** Enter the SMTP port of your email server.
4. **Outgoing SMTP Server:** Enter the SMTP server address of your email.
5. **User Name:** Enter your email address or email user name.



Chapter 9 Network Setup

9.3 Email

The screenshot shows a configuration panel for email settings. It includes fields for Password, Sender, Receiver 1, Receiver 2, Receiver 3, and Interval. A 'Show Password' checkbox is next to the Password field. A 'Test Email' button is located below the Interval field. At the bottom right, there are 'Default' and 'Apply' buttons. Red lines connect numbered callouts (6-10) to specific elements: 6 points to the Password field, 7 to the Sender field, 8 to the Receiver 1 field, 9 to the Interval dropdown menu, and 10 to the Test Email button.

- 6. Password:** Enter the password of your email. Click the “Show” checkbox if you would like to see your password.
- 7. Sender:** Input a name you would like displayed when the email arrives, such as “Home CCTV Alert”.
- 8. Receiver1-3:** Enter the email addresses to which you would like alerts sent. You can send to up to three email addresses.
- 9. Interval:** This is the length of time that must elapse after your NVR sends an email alert before it will send another.

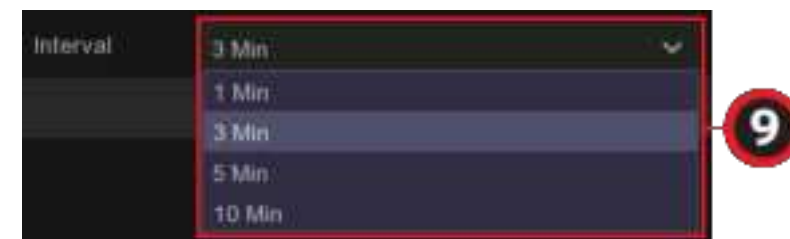

Chapter 9 Network Setup

9.3 Email

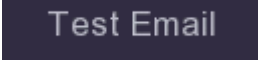
10. Test Email: To make sure all settings are correct, click . The system sends an automated email message to your inbox. If you received the test email, it means the configuration parameters are correct. Click "OK" to continue. If you do not receive the test email, check your junk or spam folder.

Email not working? Please try the following:

1. Check that your email user name and password are correct.
2. Located at the back of your NVR, you should see one or two flashing LEDs (above the Ethernet port). If you don't see this, disconnect then reconnect the Ethernet cable or try either different port on your router or a different Ethernet cable.
3. If you are using a Gmail account and you are sure all the settings are correct and you haven't received an email, or you have received an email from Google with "Sign-in attempt was blocked" you will need to go to myaccount.google.com/security and enable "Allow less secure apps".

Chapter 9 Network Setup

9.3.1 Email Schedule

You need to configure the schedule to fully implement the email notification. The various email triggers are shown as color coded rings on the right hand side of the schedule; click inside the ring corresponding to the email trigger you want to use and then drag the cursor across the days and times you want to select, to deselect an area click or drag across on the cells or you want to remove in the same manner.

The colour codes on the email schedule have the following meanings:

Green: Motion detection.

Blue: Intelligent analysis (not supported by this DVR).

Red: Exception (HDD full, HDD error, or Video Loss).

Purple: PIR (Thermal Detect).

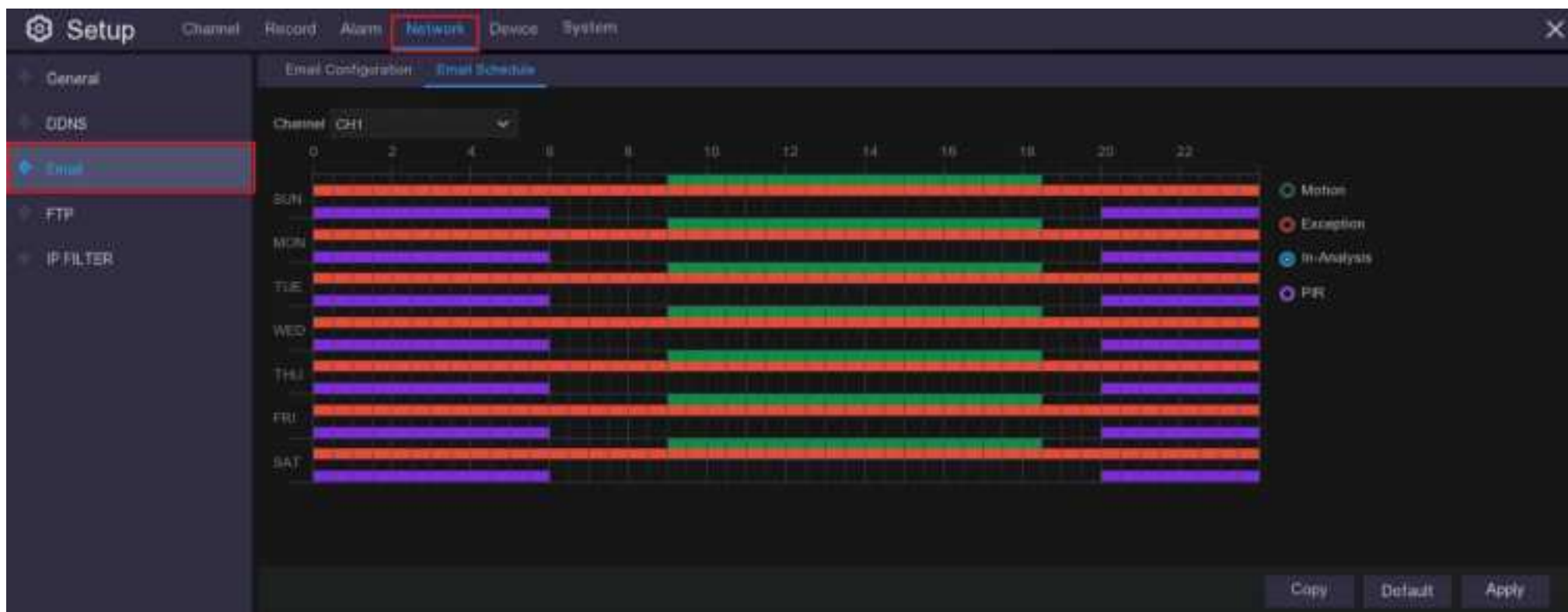

Chapter 9 Network Setup

9.4 FTP

Some customers may prefer to use an FTP client to upload their recordings, This menu allows you to enable FTP function to view and load captured snapshots from the DVR to your storage device over FTP.

FTP Enable: Click to enable FTP function.

Server IP: Enter your FTP server IP address or domain name.

Port: Enter the FTP port for file exchanges.

Name/ Password: Enter your FTP server user name and password.

Directory Name: Enter the default directory name for the FTP file exchanges.

Test FTP: Click to test the FTP settings.

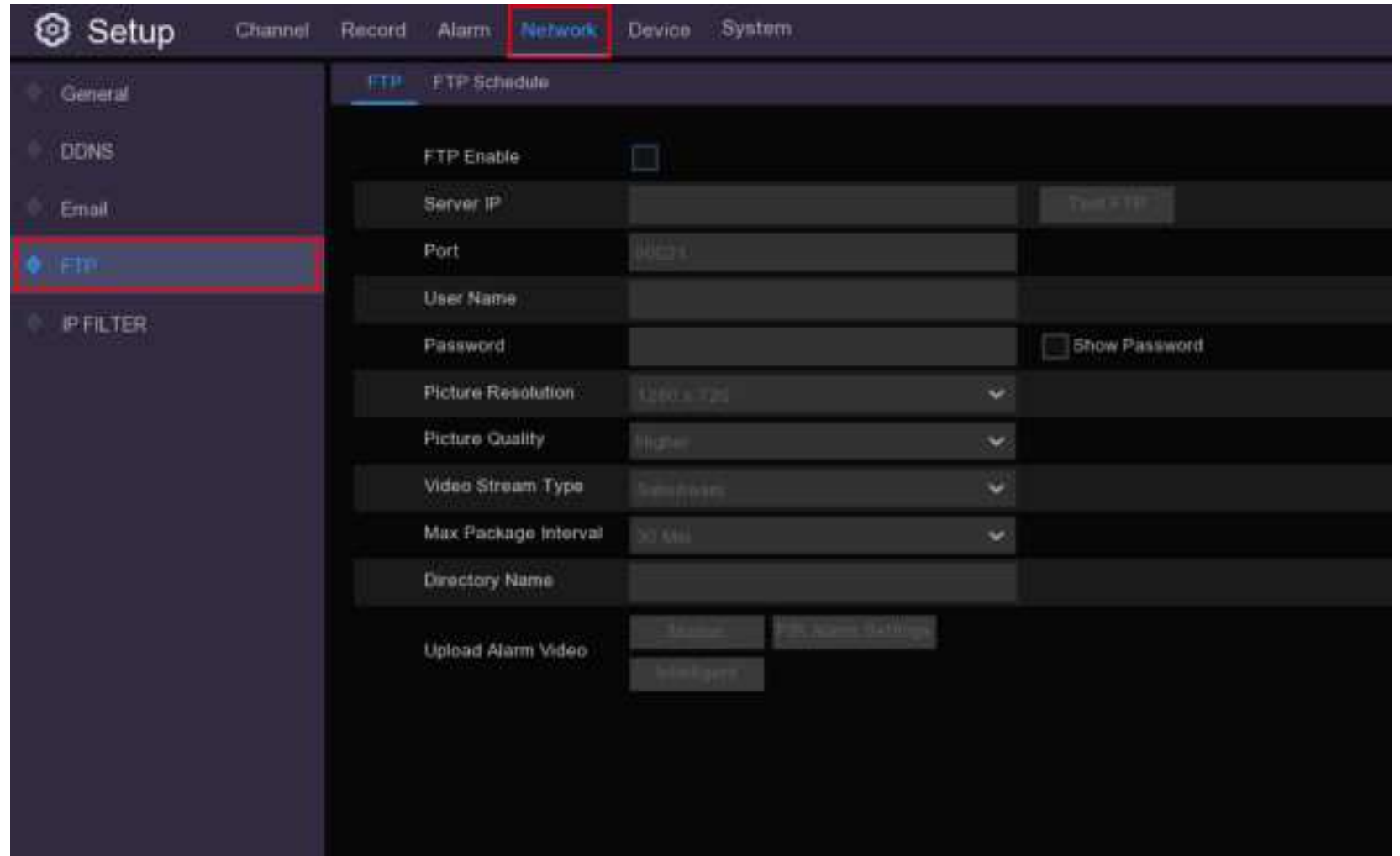

The screenshot shows the 'Setup' interface with the 'Network' tab selected. The 'FTP' sub-tab is active, displaying the following configuration options:

Field	Value	Action
FTP Enable	<input type="checkbox"/>	
Server IP	<input type="text"/>	Test FTP
Port	<input type="text"/>	
User Name	<input type="text"/>	
Password	<input type="password"/>	<input type="checkbox"/> Show Password
Picture Resolution	1280 x 720	▼
Picture Quality	Higher	▼
Video Stream Type	Snapshot	▼
Max Package Interval	30 s	▼
Directory Name	<input type="text"/>	
Upload Alarm Video	<input type="checkbox"/>	File Name Settings

Chapter 9 Network Setup

9.4.1 FTP Schedule

You need to configure the schedule to fully implement the FTP uploads. The various recording triggers are shown as color coded rings on the right hand side of the schedule; click inside the ring corresponding to the recording trigger you want to use and then drag the cursor across the days and times you want to select, to deselect an area click or drag across on the cells or you want to remove in the same manner.

The colour codes on the email schedule have the following meanings:

Yellow: Motion.

Purple: PIR (Thermal Detect).

Blue: Intelligent analysis (not supported by this DVR).



Chapter 10 Device Setup

In this menu you will find options that apply to your HDD and Cloud storage functions.

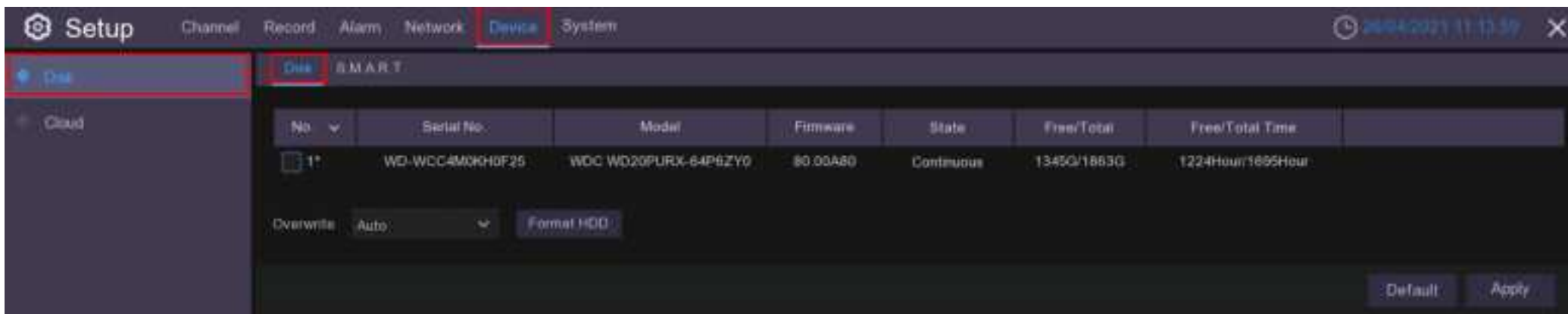

10.1 Disk

If you click **Format the HDD** you will erase all stored data on the **HDD**, you want to do this to make sure you have a fresh start.

Auto Overwrite makes new data overwrite the old data as the **HDD** fills up.

If you disable the **Auto Overwrite** feature, no new footage will be captured once the HDD is full.

You can also choose to automatically overwrite the data at different time periods from once a day to every ninety days. This ensures you keep your recordings for the period of time you think is most suitable.

When you have finished making your selection click **Apply** to continue. Clicking **Default** will reset to factory settings.

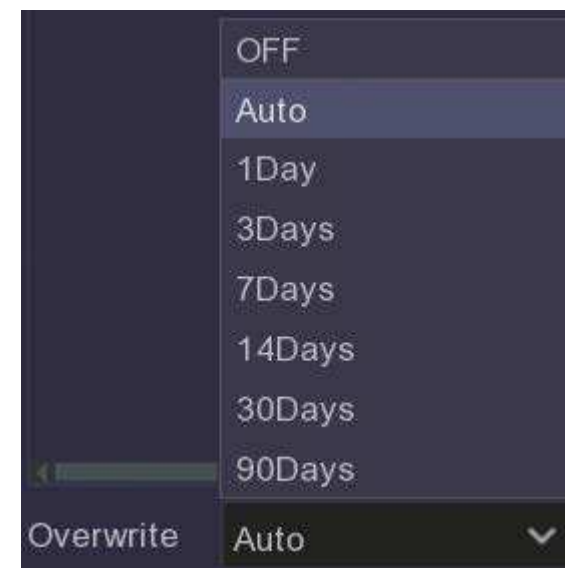

Chapter 10 Device Setup

10.2 S.M.A.R.T.

S.M.A.R.T. (Self-Monitoring, Analysis and Reporting Technology) is used to detect and report various indicators of **HDD** reliability, so you can save data to another source if the HDD is at risk of failure. You can also perform a test (there are three types available) to evaluate and detect potential drive errors.

Self-check Type: There are three types available:

Short: This test verifies major components of the hard drive such as read/write heads, electronics and internal memory.

Long: This is a longer test that verifies the above as well as performing a surface scan to reveal problematic areas (if any) and forces bad sector relocation

Conveyance: This is a very quick test that verifies the mechanical parts of the hard drive are working.

Note: When performing a test, your DVR will continue to work as normal. If an **HDD S.M.A.R.T** error is found, the **HDD** can continued to be used, but there will be a risk of losing recorded data. It is recommended to replace the HDD with a new one. **Talk to your place of purchase about this procedure, do not attempt it yourself.**

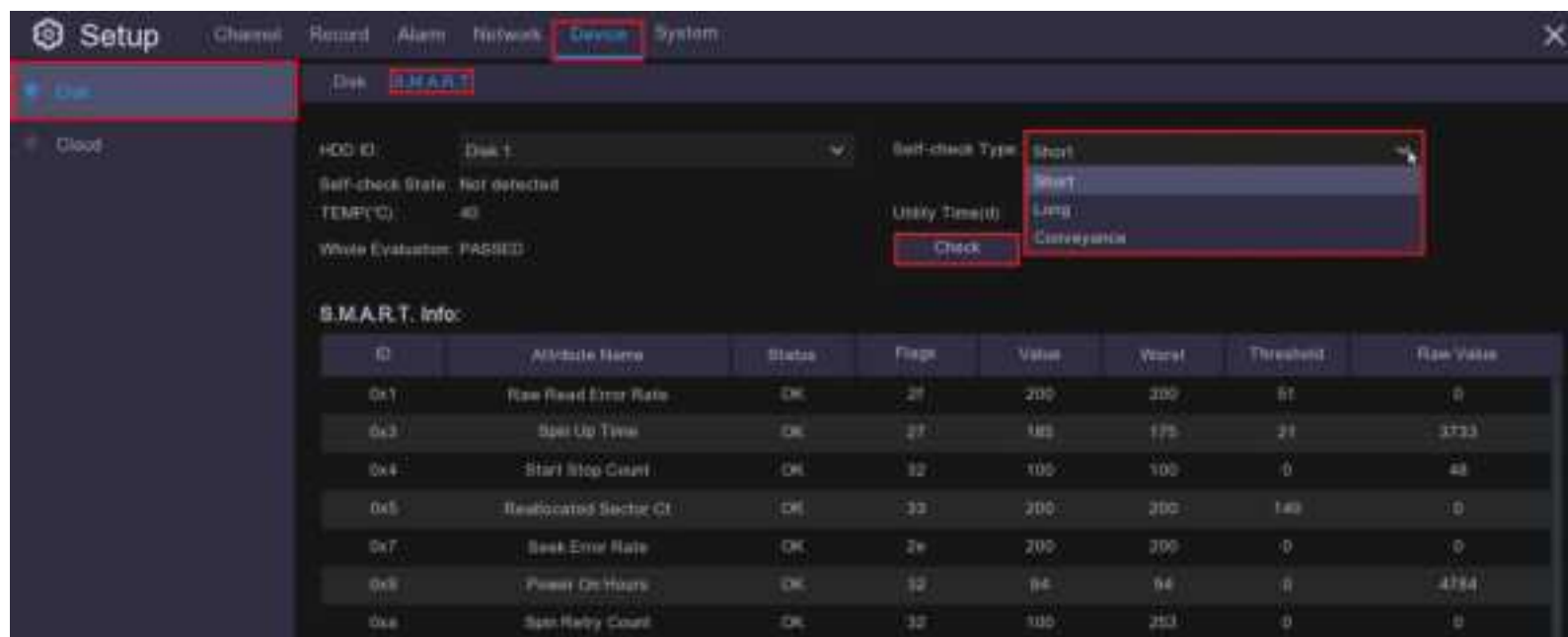

Chapter 10 Device Setup

10.3 Cloud

Your DVR can upload videos and image captures to either Dropbox or Google Drive which are both free services that allow you to easily store and share snapshots and always have them on hand when you need them. Because the free cloud space is fairly limited you should clear out your recordings fairly frequently as, depending on your recording settings, you can use a lot space quickly.

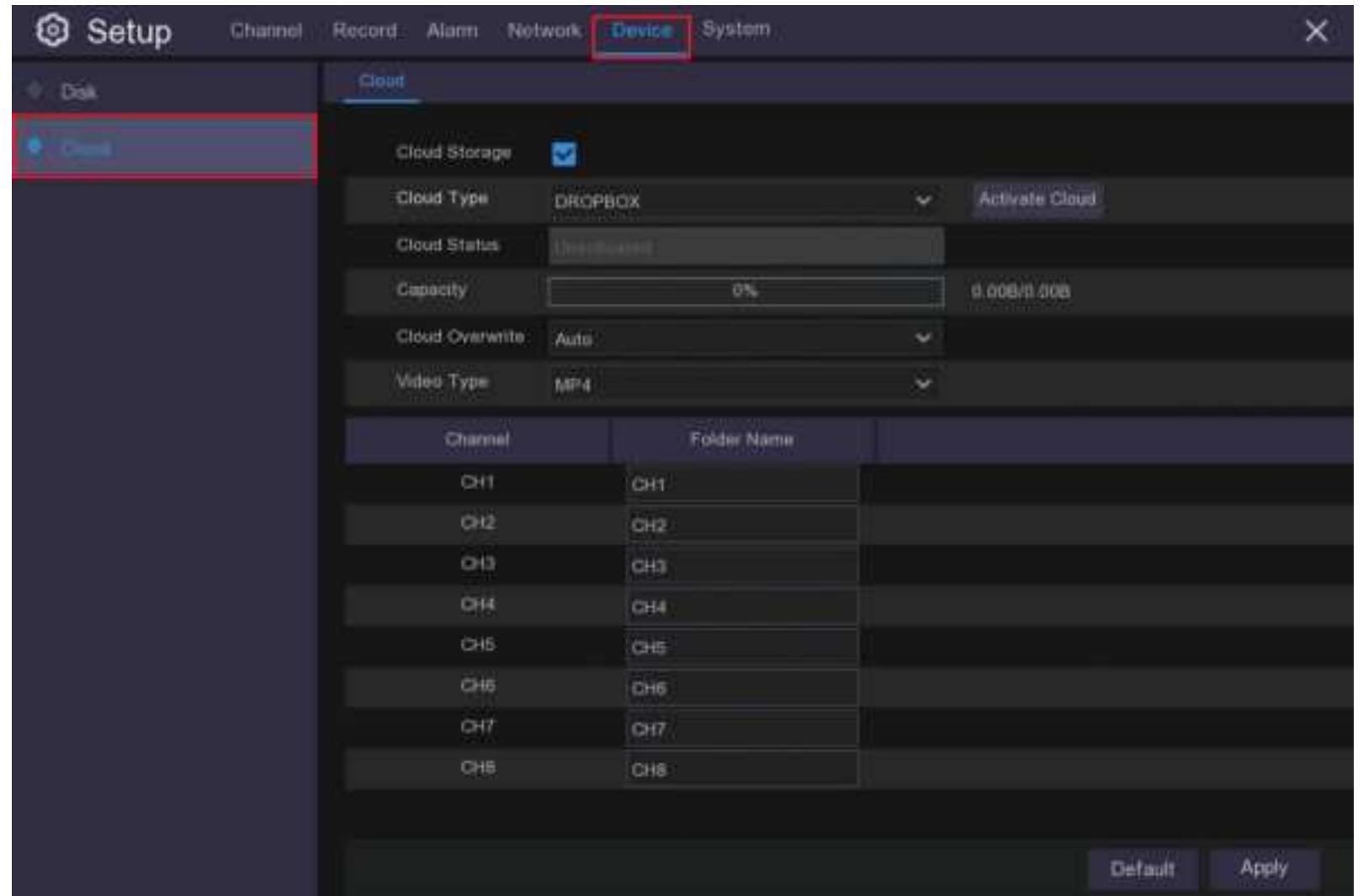

Chapter 10 Device Setup

10.3 Cloud

The cloud function on your DVR will only work with **Dropbox** or **Google Drive** so you need to have setup an account with one of these services before you can activate the function on your DVR. The account must use the same email address and password used for the **Email** setup in your DVR (see **9.3 Email**).

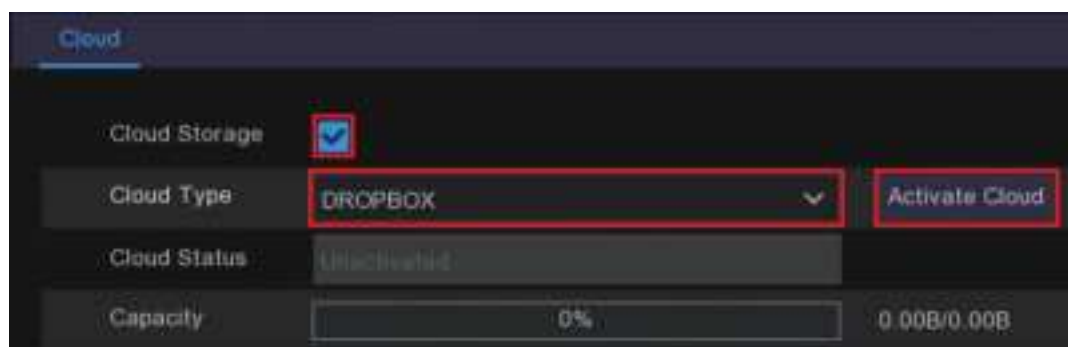

Cloud Storage: Check to enable the function.

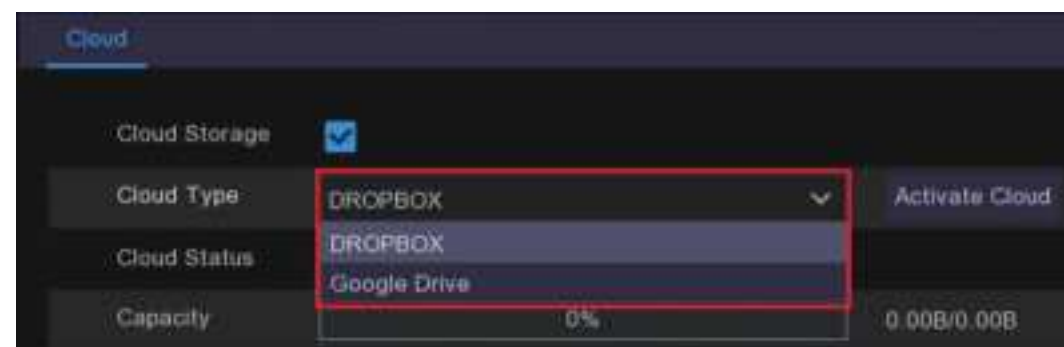

Cloud Type: Select Dropbox or Google Drive.

Activate Cloud: Click to activate the function. After a short moment, you will see a message on-screen. An activation link has been sent to your email (the email address which you had set to receive email alerts in **9.3 Email**). Check your email then click the link to activate. Just follow the steps provided by your chosen service and you are done.

Chapter 10 Device Setup

10.3 Cloud

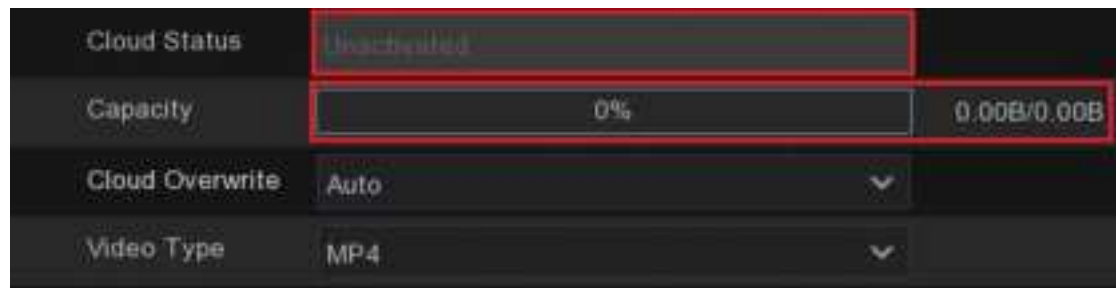

Cloud Status: After you have successfully completed the cloud service activation process this box will be changed to Activated.

Capacity: The amount of capacity you have available in your cloud storage will be shown here.

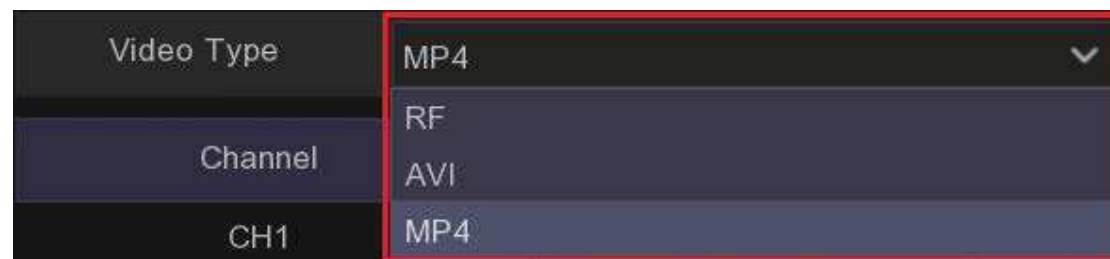
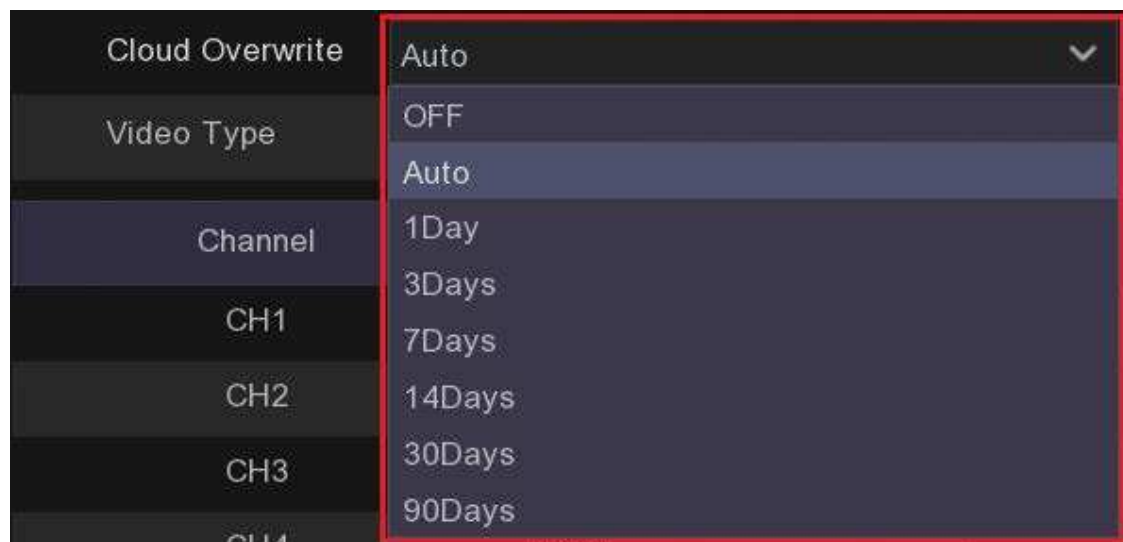

Video Type: This drop down menu allows you to specify what type of video you wish to save.

Cloud Overwrite: You can choose to regularly overwrite your cloud storage so you aren't wasting space with recordings you don't need, the same as you can do with your HDD storage. Select the period of time for which you wish to retain recordings.

Chapter 10 Device Setup

10.3 Cloud

Channel	Folder Name
CH1	CH1
CH2	CH2
CH3	CH3
CH4	CH4
CH5	CH5
CH6	CH6
CH7	CH7
CH8	CH8

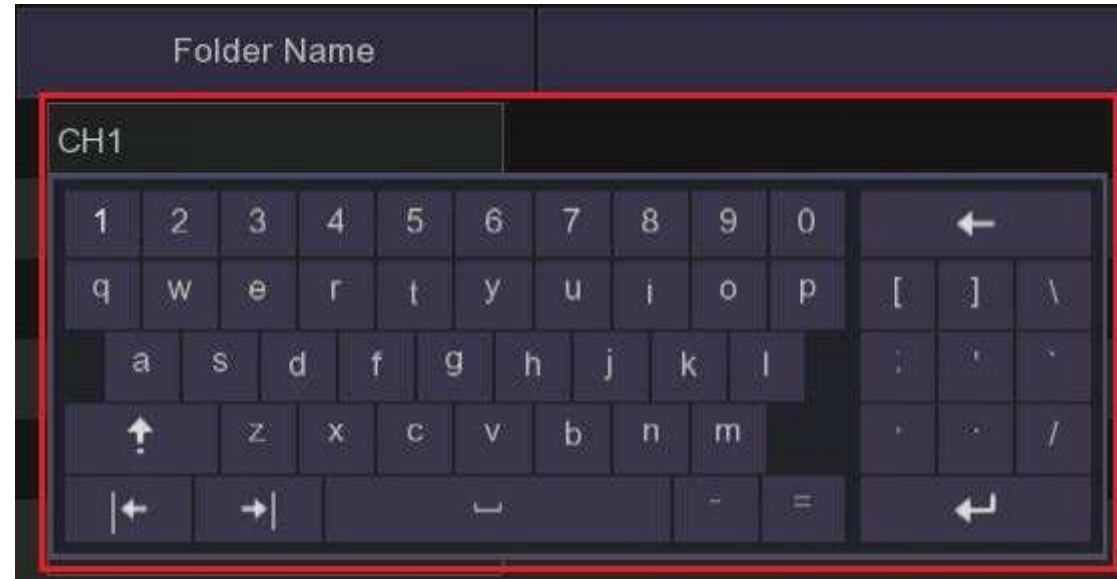

Folder Name: Each channel will have its own folder within your cloud service, you can change the name of these folders by clicking on them and using the on screen keyboard to give them a name that is more relevant to you.

Chapter 11 System

11.1 System General Menu

In this menu you change general system information such as date, time and region, edit passwords and permissions, and more.

11.1.1 General

Device Name: In this field you can change the name of your DVR using the on-screen keyboard.

Device ID: You can choose to allocate an ID number in this field.

Language: You can choose a different language for your DVR to use on-screen.

Video Format: Some monitors and TVs may work better with PAL or NTSC, you can select which protocol to use in this menu.

Menu Timeouts: This drop down allows you to select the amount of time when using the Setup and Playback that your DVR is idle before it reverts back to the live view. You can choose from **30secs, 1, 2, 5 or 10 minutes** or turn **OFF Timeouts**.

Show wizard: If this is ticked your DVR will run the Start-up Wizard every time you restart it. Untick to turn this off.

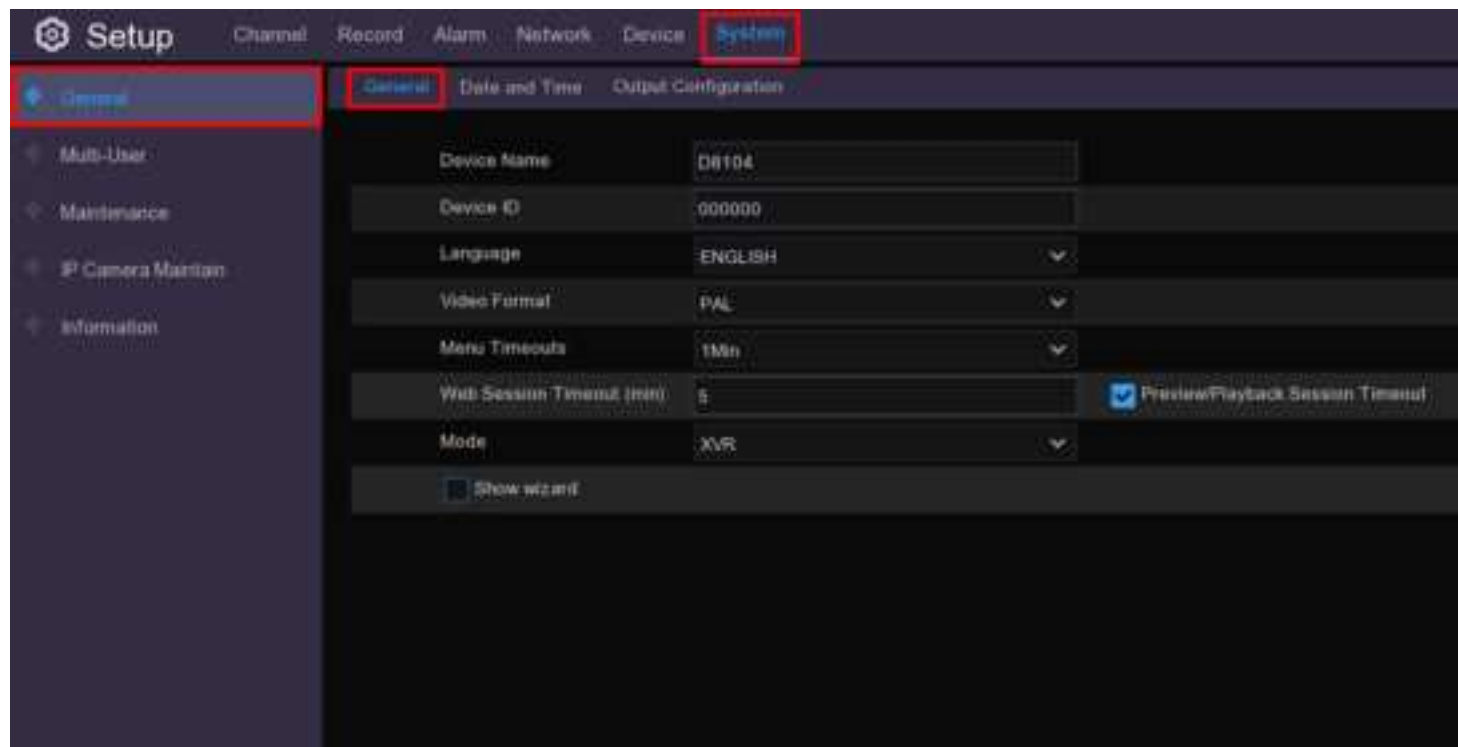

Chapter 11 System

11.1.2 Date and Time

This menu will set the system date and time, click the tabs to make adjustments.

Date and Time: Set date, time, formats and time zone.

NTP: You can also choose NTP (network time protocol) to automatically set the time using the network.

DST: Set when DST (daylight saving time) begins and ends so the system will automatically adjust itself.

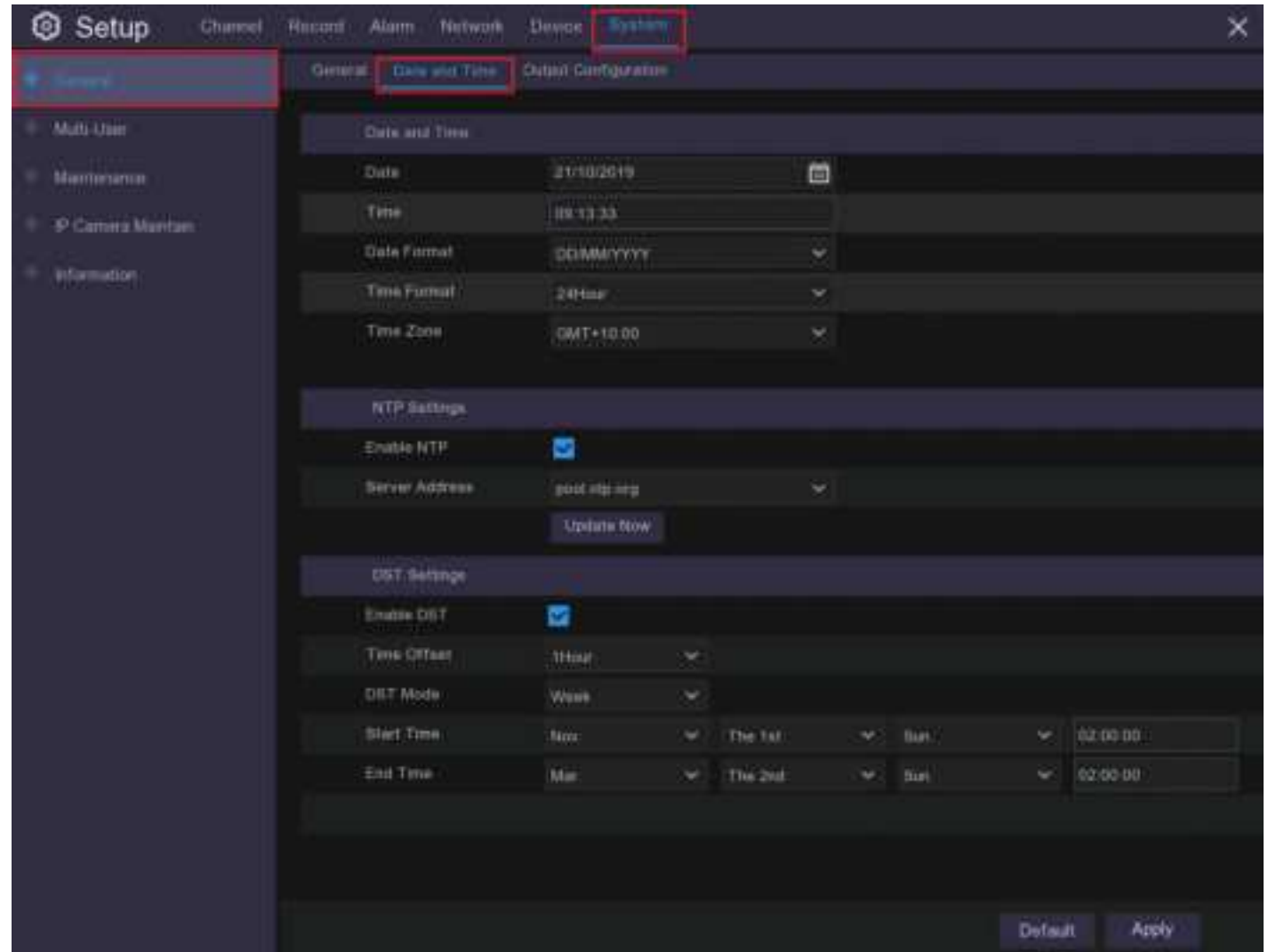

Chapter 11 System

11.1.3 Output Configuration

This menu is used to create the default format for the **Live View** screen.

Your DVR only has **LIVE-OUT** from the **Video Output** drop-down menu.

SEQ Mode: The **SEQ Mode**  is a mode available in the **Live View** where the feed from each camera is scrolled on the screen either as a single camera view or four or six cameras at a time. Most people will choose **Layout 1** which will show one channel at a time but you can choose **Layout 4** or **Layout 6**, which are more relevant if you have six or more cameras operating.

SEQ Dwell Time is the amount of time that each channel is displayed. Using the on-screen keyboard enter the number of seconds you would like to display a video channel in the sequence mode before displaying the next video channel (300 seconds is the maximum).

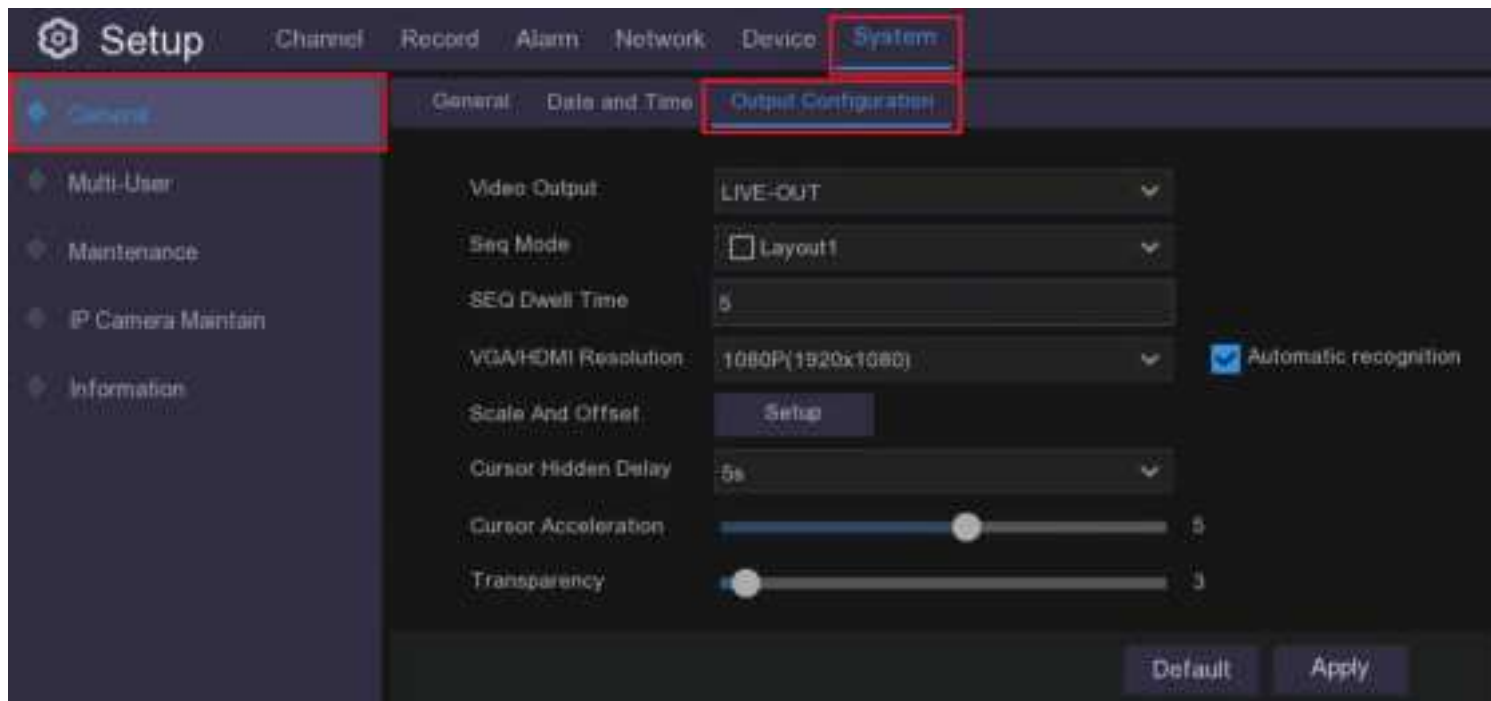

Chapter 11 System

11.1.3 Output Configuration

Output Resolution: Select a display resolution that is suitable for your TV. 1920 x 1080 will suit most TVs.

Scale and Offset: The DVR supports to adjust the size & position of the display screen to match your monitor or TV. Click Setup button to adjust.

Scale And Offset

Setup



Scale and Offset: Use this function to adjust the size & position of the display screen to match your monitor or TV. Click Setup button to adjust. This can be useful if you have a screen in screen option on your TV and you want to be able to make the CCTV image smaller than the whole screen.

Scale will adjust X & Y axes relative to each other.

X Offset and **Y Offset** will adjust X & Y axes independently. Use the  buttons to adjust.



Chapter 11 System

11.1.3 Output Configuration

Cursor Hidden Delay: Use this drop down menu to specify the amount of time the cursor is visible on the Live View screen when not in use, up to four minutes.

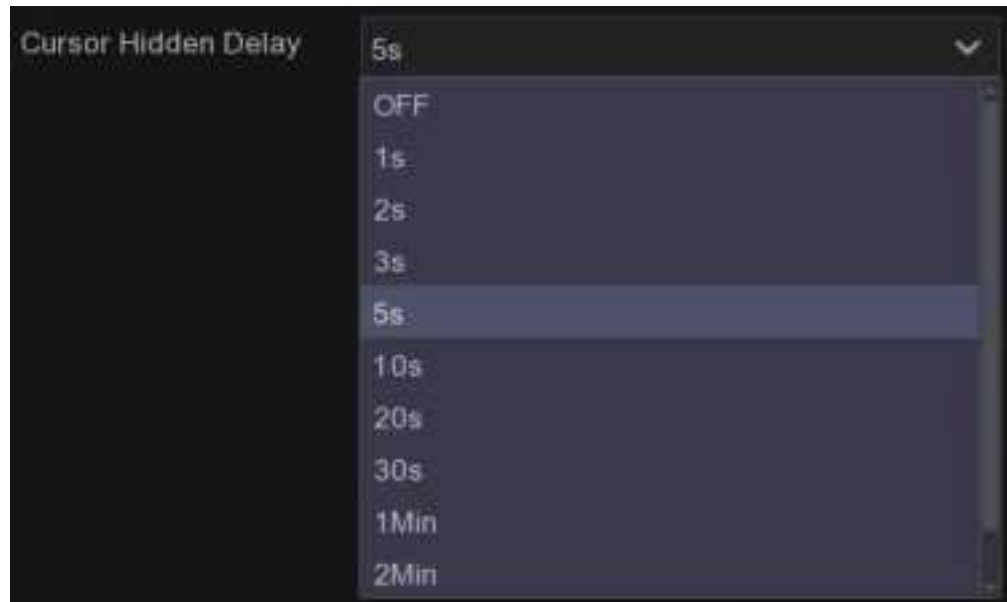

Cursor Acceleration: This slider adjusts the speed at which the cursor moves relative to mouse movement.

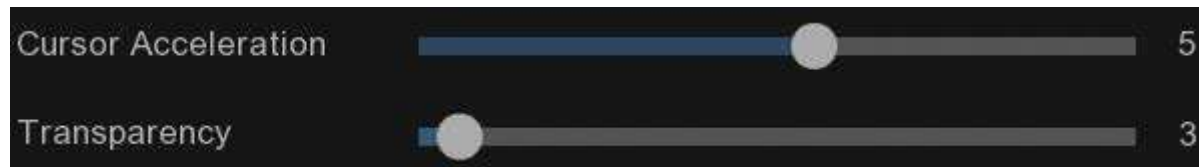

Transparency: This slider adjusts the transparency of the Menu Bar and Main Menu. The higher the number the more see-through the menus become. This is purely an aesthetic preference.

Chapter 11 System

11.2 Multi-User

This menu allows you to configure the user name, password and user permission.

The system supports two account types:

- **ADMIN — System Administrator:** The administrator has full control of the system, and can change both administrator and user passwords and enable/disable password
- **USER — Normal User:** Users only have access to live viewing, search, playback, and other functions. You may set up multiple user accounts with varying levels of access to the system.

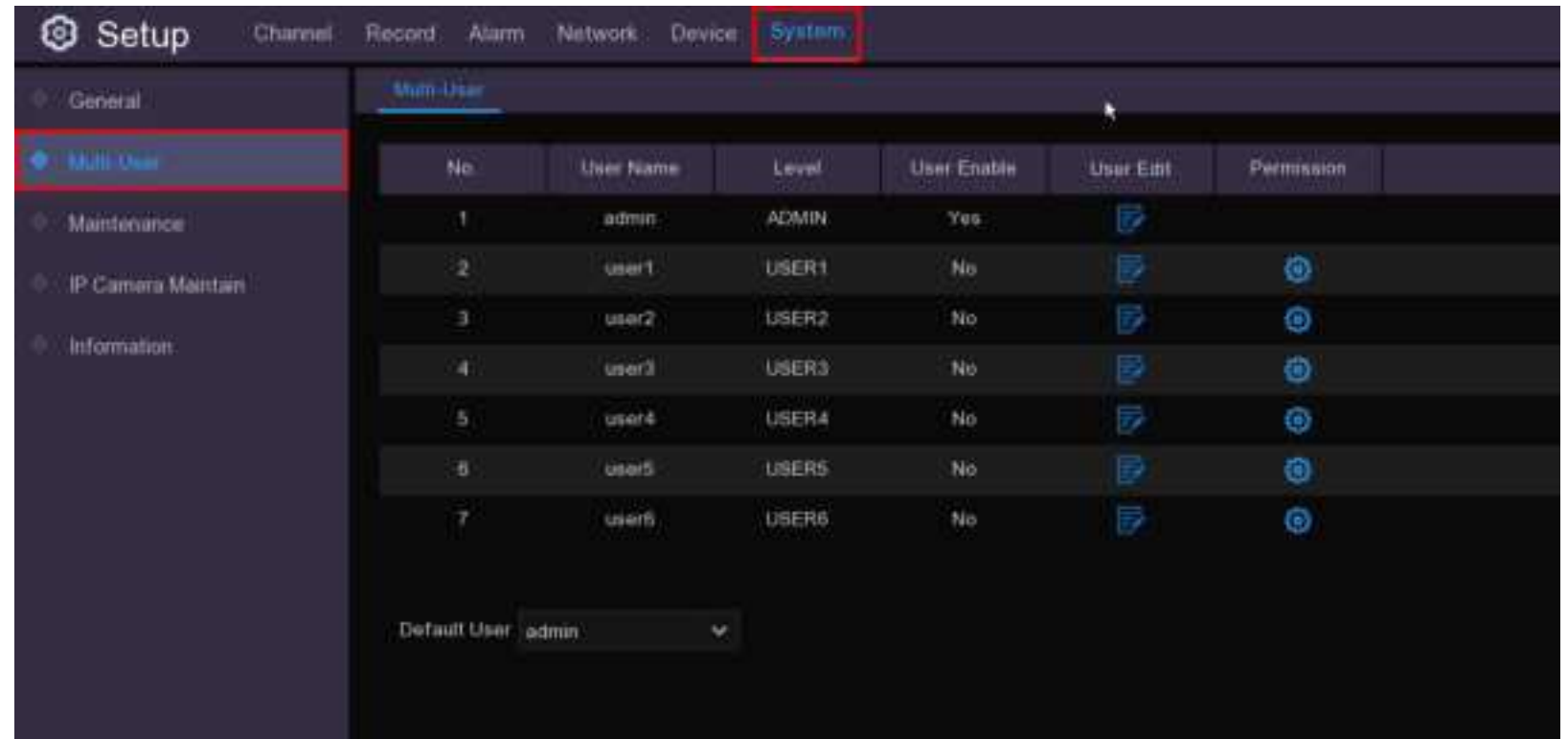

The screenshot shows the 'System' setup page in a dark-themed interface. The 'System' menu item is highlighted in the top navigation bar. On the left sidebar, the 'Multi-User' option is selected and highlighted with a red border. The main content area displays a table of users with the following columns: No., User Name, Level, User Enable, User Edit, and Permission. Below the table, there is a 'Default User' dropdown menu set to 'admin'.

No.	User Name	Level	User Enable	User Edit	Permission
1	admin	ADMIN	Yes		
2	user1	USER1	No		
3	user2	USER2	No		
4	user3	USER3	No		
5	user4	USER4	No		
6	user5	USER5	No		
7	user6	USER6	No		

Default User: admin

Chapter 11 System

11.2.1 Changing Admin Password

To change the password for the administrator or user accounts, click the User Edit icon . The password has to be a minimum of 8 characters and can contain a mixture of numbers and letters. Enter your new password again to confirm, and then click Save to save your new password. You will be required to input your old password to authenticate

User Name: You can change your username to any combination of letters and numbers using the onscreen keyboard.

Password Enable: It's strongly recommended to enable the password to protect your privacy. If you want to disable the password protection, please ensure your DVR is placed in a secure place.

Unlock Pattern Enable: You can choose to use a pattern instead of a password, if you prefer.

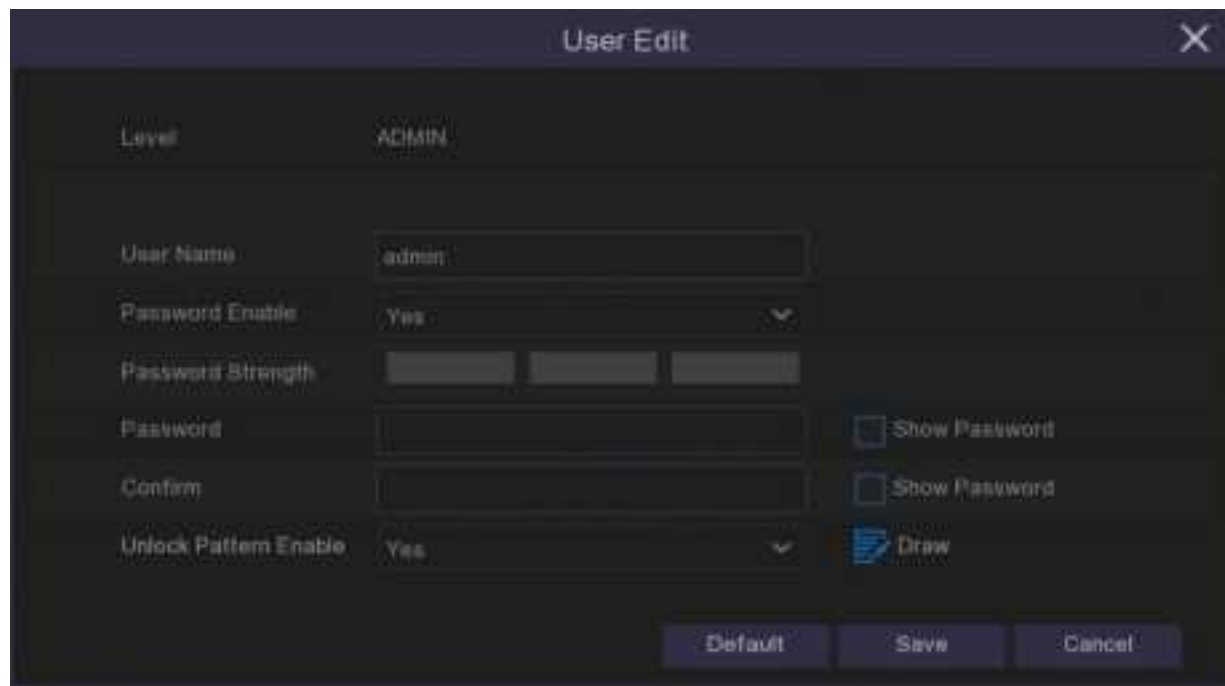

The image shows a 'User Edit' dialog box with a dark background. At the top, it says 'User Edit' with a close button (X). Below this, there are several fields and options:

- Level:** ADMIN
- User Name:** admin
- Password Enable:** Yes (with a dropdown arrow)
- Password Strength:** Three progress bars of varying lengths.
- Password:** A text input field with a 'Show Password' checkbox to its right.
- Confirm:** A text input field with a 'Show Password' checkbox to its right.
- Unlock Pattern Enable:** Yes (with a dropdown arrow)
- Draw:** A blue icon representing a drawing tool.

At the bottom right, there are three buttons: 'Default', 'Save', and 'Cancel'.



The image shows a 'Set Unlock Pattern' dialog box with a dark background. At the top, it says 'Set Unlock Pattern' with a close button (X). Below this, there is a 3x3 grid of nine circles, which is used for setting a pattern. The circles are arranged in three rows and three columns.

Chapter 11 System

11.2.2 Add New Users

1. Select one of the user accounts that is currently disabled, click the User Edit icon .
2. Select Enable from the drop-down next to User Enable.
3. Click the field next to User Name to change the user name for the account.
4. Select Enable from the drop-down next to Password Enable.
5. Click the field next to Password to enter the desired password.
6. Click the field next to Confirm to reenter the password.
7. Click Save. You will be required to input your Admin password to authenticate.

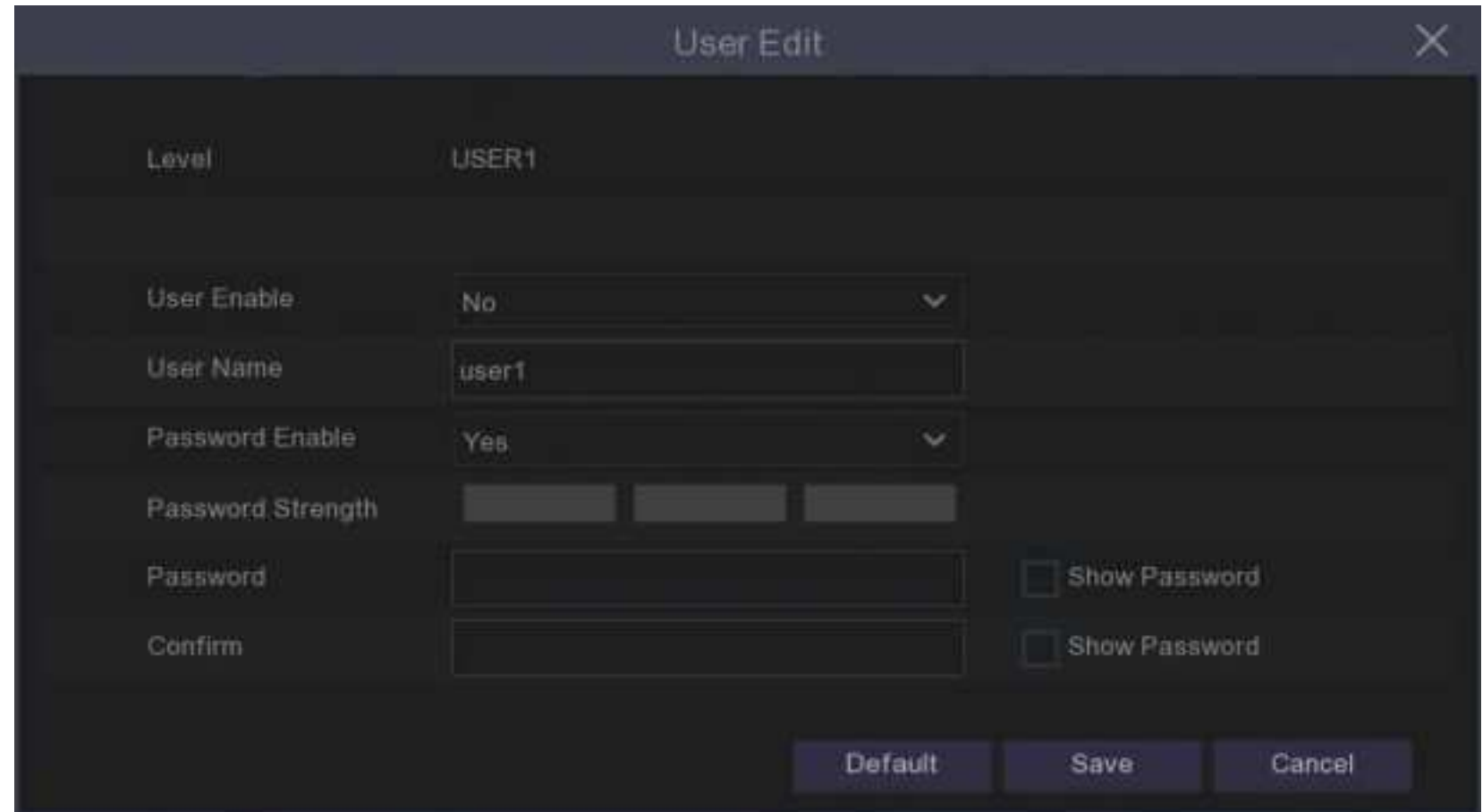





The image shows a 'User Edit' dialog box with a dark theme. At the top, it says 'User Edit' and has a close button (X). Below that, the user's level is shown as 'USER1'. The form contains several fields and controls:

- User Enable:** A drop-down menu currently set to 'No'.
- User Name:** A text input field containing 'user1'.
- Password Enable:** A drop-down menu currently set to 'Yes'.
- Password Strength:** Three progress bars representing password strength indicators.
- Password:** A text input field for the password.
- Confirm:** A text input field for re-entering the password.
- Show Password:** Two checkboxes, one for the Password field and one for the Confirm field, both currently unchecked.
- Buttons:** At the bottom right, there are three buttons: 'Default', 'Save', and 'Cancel'.

Chapter 11 System

11.2.3 New Users

The administrator account is the only account that has full control of all system functions. You can enable or disable access to certain menus and functions of each user account using the **User Permission** menu.

No.	User Name	Level	User Enable	User Edit	Permission
1	admin	ADMIN	Yes		
2	user1	USER1	No		
3	user2	USER2	No		

1. To enter this menu click the edit icon  under the **Permission** tab on the **System > Multi-User** menu.
2. Once in this menu you can allocate various permissions to the individual user to access system menus such as **Manual Record** and **Capture**.
3. You can also give them access individual channels within **Live View**, **Playback** and **Backup** menus.
4. If you click the **All** button all the **Permission** boxes will be ticked, conversely if you click **Clear** all the **Permission** boxes will be cleared.
5. Remember to click **Save** when you have finalised your selections.

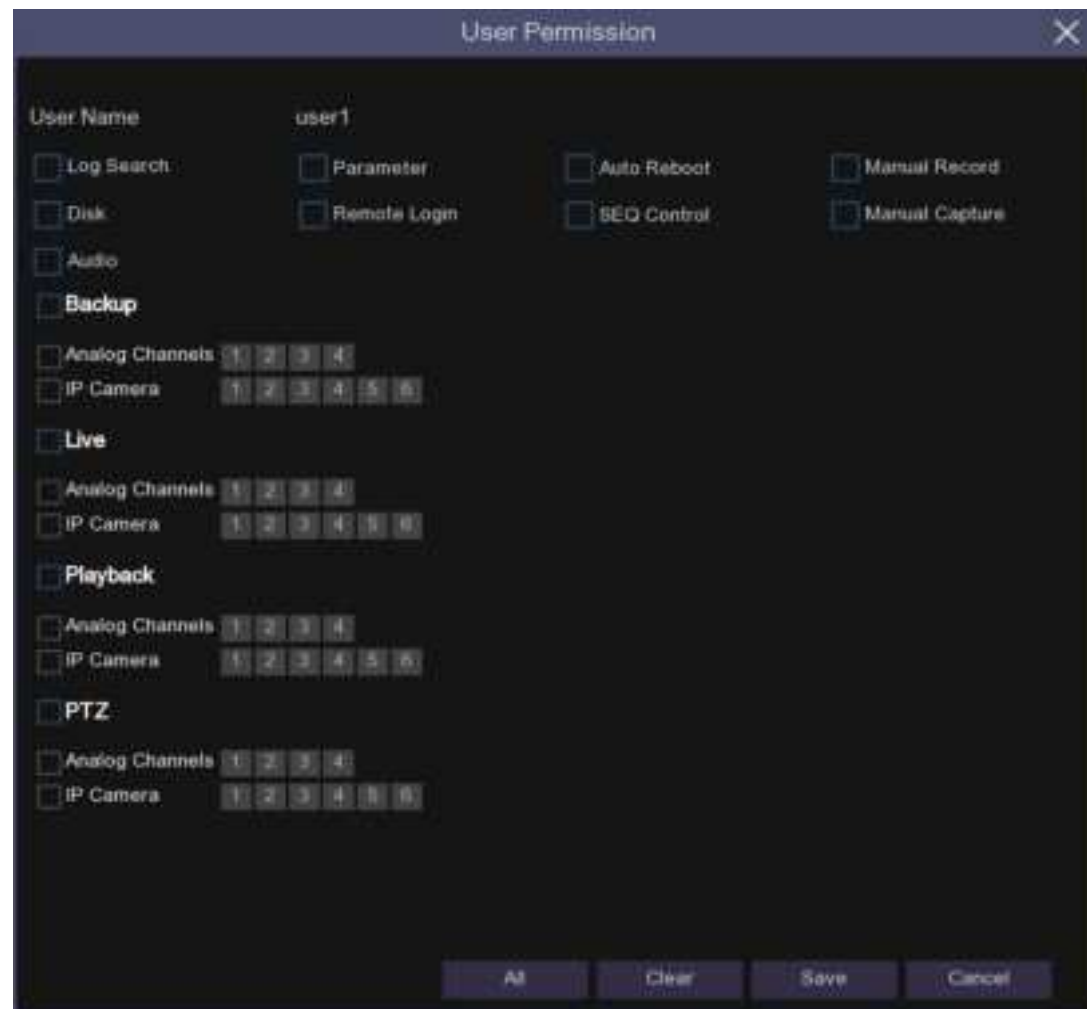

User Permission

User Name: user1

Log Search Parameter Auto Reboot Manual Record
 Disk Remote Login SEQ Control Manual Capture
 Audio
 Backup
 Analog Channels 1 2 3 4
 IP Camera 1 2 3 4 5 6
 Live
 Analog Channels 1 2 3 4
 IP Camera 1 2 3 4 5 6
 Playback
 Analog Channels 1 2 3 4
 IP Camera 1 2 3 4 5 6
 PTZ
 Analog Channels 1 2 3 4
 IP Camera 1 2 3 4 5 6

Chapter 11 System

11.3 Maintenance

In this section, you will be able to search & view the system log, load default settings, upgrade the system, export & import system parameters and manager system auto reboot.



Channel	Type	TIME	CON	RECORD	Playback
	System	01/10/2019 00:07:50	NTP		
	System	01/10/2019 00:07:50	NTP		
CH3	Alarm	01/10/2019 00:26:08	Motion Start	Yes	<input type="checkbox"/>
CH3	Alarm	01/10/2019 00:26:38	Motion End	Yes	<input type="checkbox"/>
CH3	Alarm	01/10/2019 03:55:50	Motion Start	No	
CH3	Alarm	01/10/2019 03:56:20	Motion End	No	
CH3	Alarm	01/10/2019 03:56:47	Motion Start	No	

Chapter 11 System

11.3.1 Log

The system log shows you important system events, such as motion alarms and system warnings. You can easily create a backup file of the system log for a set time period to a USB flash drive.

Log Searching and Backing Up:

1. Click the  icon next to **Start Date & Start Time** to choose the start of your search from the on-screen calendar.
2. Click the  icon next to **End Date & End Time** to choose the end of your search from the on-screen calendar.
3. Select the type of events you would like to search for from the dropdown next to **Log Type**, or select **All** to see the entire system log for the selected time period.
4. Click **Search**.
5. Browse system log events from your search period:
 - Video events can be played back instantly by clicking in the **Playback**  icon. Right-click to return to your search results.
 - Use the / buttons in the bottom-right corner of the menu to move between pages of system log events.
6. Click **Backup** to create a backup of the system log for your search period. Please make sure your flash drive has been connected to the DVR's USB port.
7. The backup drive menu appears. Navigate to the folder you want the backup file to be saved in, then click OK to begin.

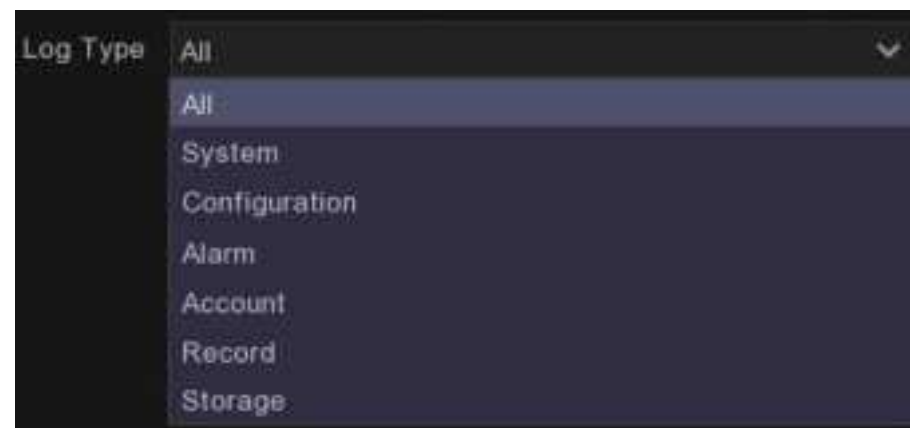

Chapter 11 System

11.3.2 Load Default

In this menu you can reset the DVR to its out-of-box settings. This can be helpful if your system is not operating the way it used to and you can't work out which changes you have made have affected its behavior.

You can choose to reset all settings at once, or just settings on specific menus. Restoring default settings will not delete recordings and snapshots saved to the hard drive.

When you have selected the settings you want to return to default simply click **Apply** to activate this change.

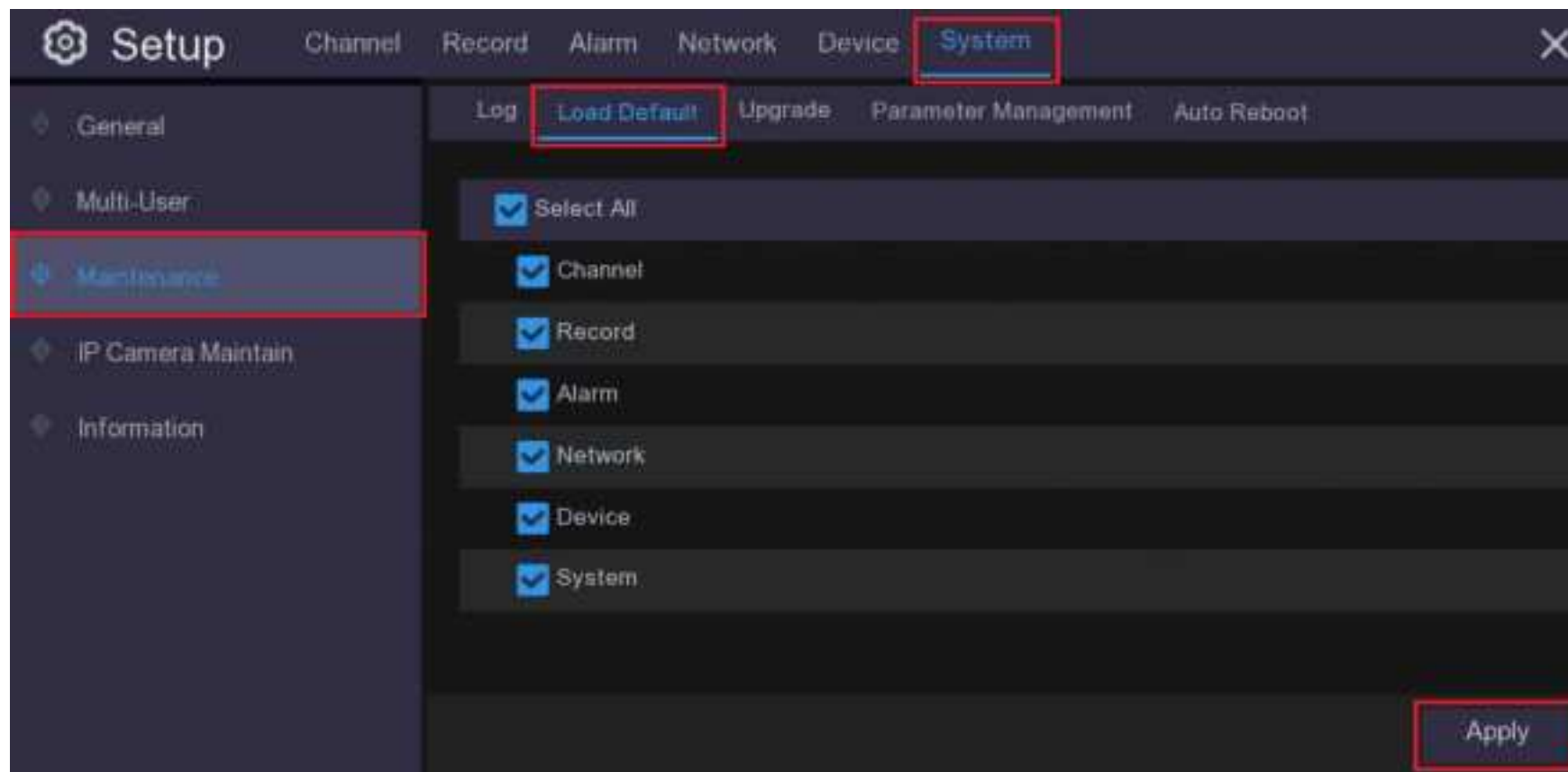

Chapter 11 System

11.3.3 System Upgrade

If our engineers come up with some major changes to the software that we believe all customers will benefit from you will be able to upload this software directly to your DVR. If there is an upgrade available on the website simply download that to a clean **USB storage device** and connect that storage device to one of the **USB ports** on your DVR. Now open up the **Upgrade** tab within **Maintenance**, click on the **Select File** button and an **Update** window will pop up, select the USB device you are using in the **Driver List** on the left (you may need to refresh the list using the  button) then select the file you saved from the website and click OK. You will then return to the previous window with the file you have just selected showing, now click on **Upgrade** and the system will automatically update. *Note: you will lose all settings.*

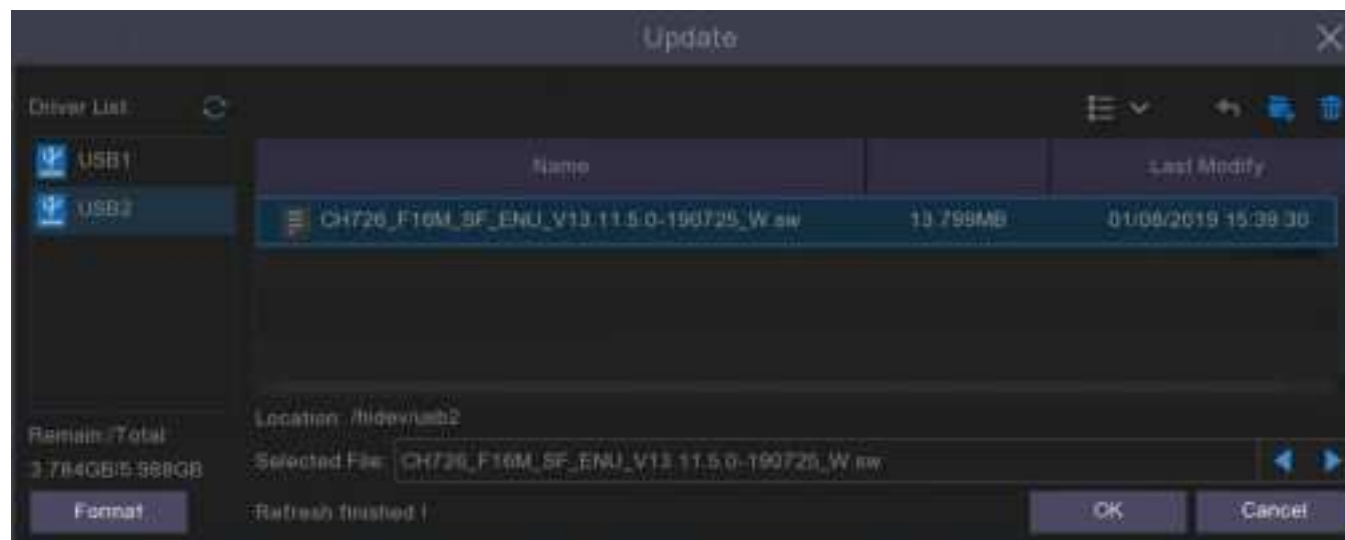
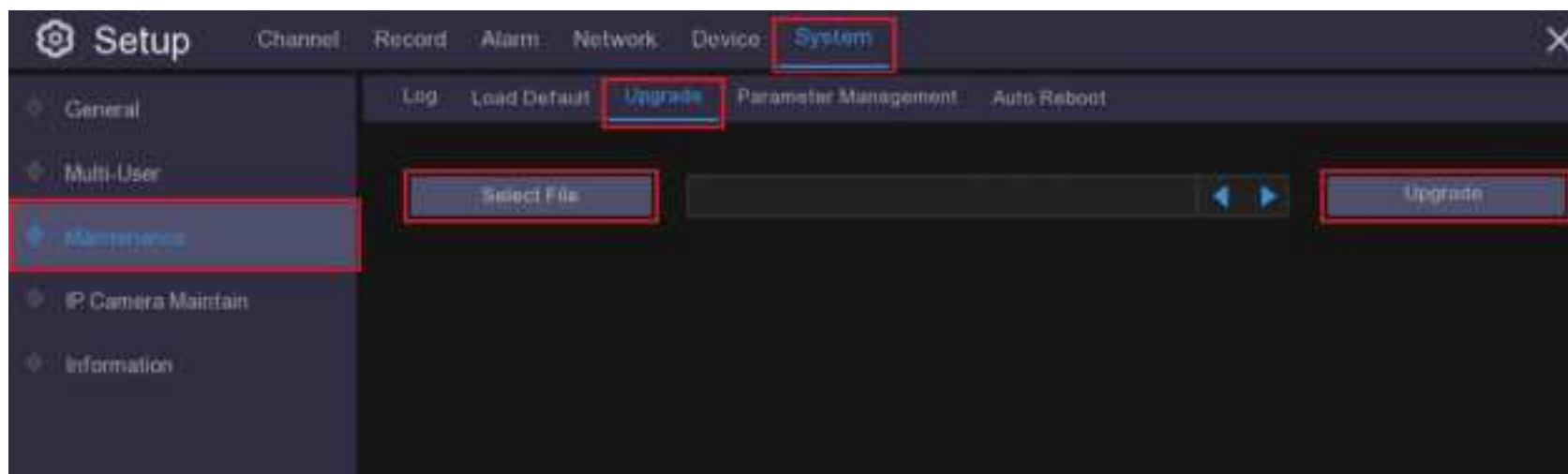

Chapter 11 System

11.3.4 Parameter Management

You can export the main menu settings you have configured to a **USB flash drive**, or import an exported setting file from a USB flash drive to the DVR. It is a good idea to do this prior to doing an upgrade or if you want to copy your settings to another DVR.

Save Settings: Click to save the current DVR system settings to the USB device. You will be required to input the Admin password to authenticate.

Load Settings: Click the **Load Settings** button to navigate to the system settings file you want to import from your USB flash driver. You will be required to input the Admin password to authenticate.

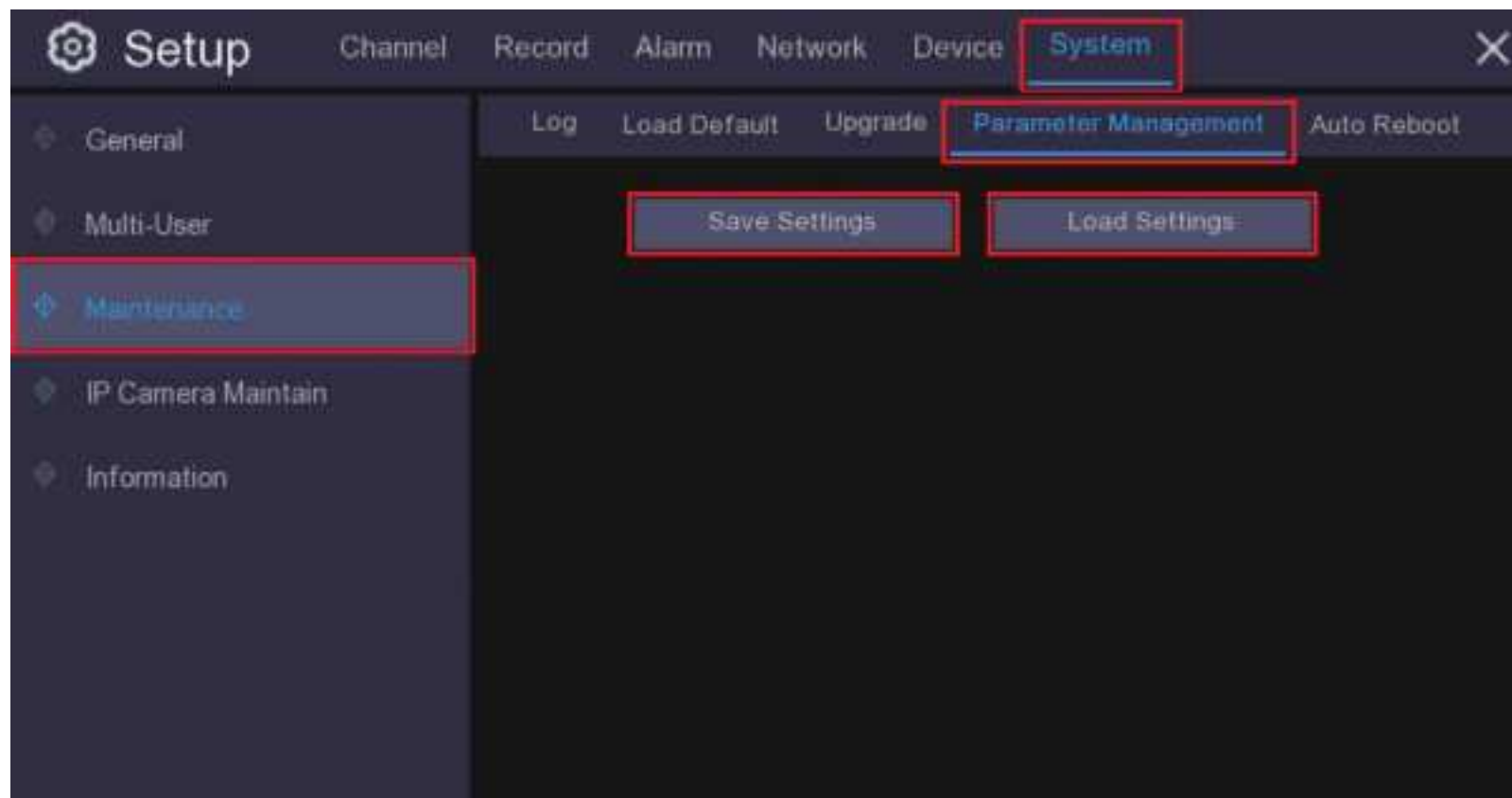

Chapter 11 System

11.3.5 Auto Reboot

This menu allows the system to auto reboot the DVR regularly. It is recommended to leave this function enabled, as it maintains the operational integrity of your DVR.

Auto Reboot: Check to enable.

Time: You can set the DVR to reboot every day, week or month.

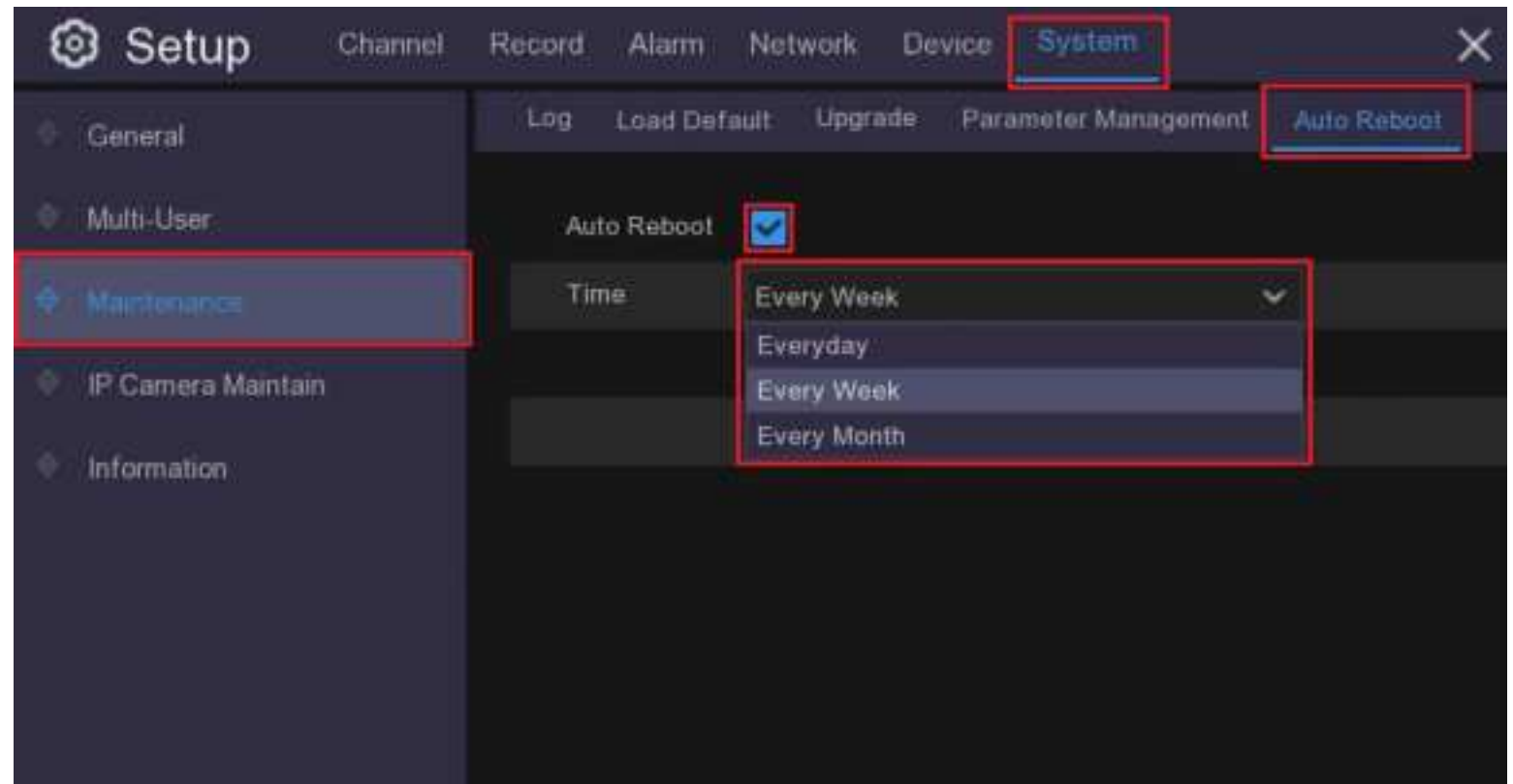

Chapter 11 System

11.4 IP Camera Maintain

This menu applies to systems that are using IP cameras through a network router and do not apply to standard DVR cameras using a BNC connector. If you would need information on maintaining IP cameras please use the NVR manual.

Chapter 11 System

11.5 Information

This menu allows you to view the system information, channel information, record information & network status.

The most important part of this page is you will find the P2P ID & P2P QR code here. You can scan this QR code with the mobile app to remotely view the DVR.

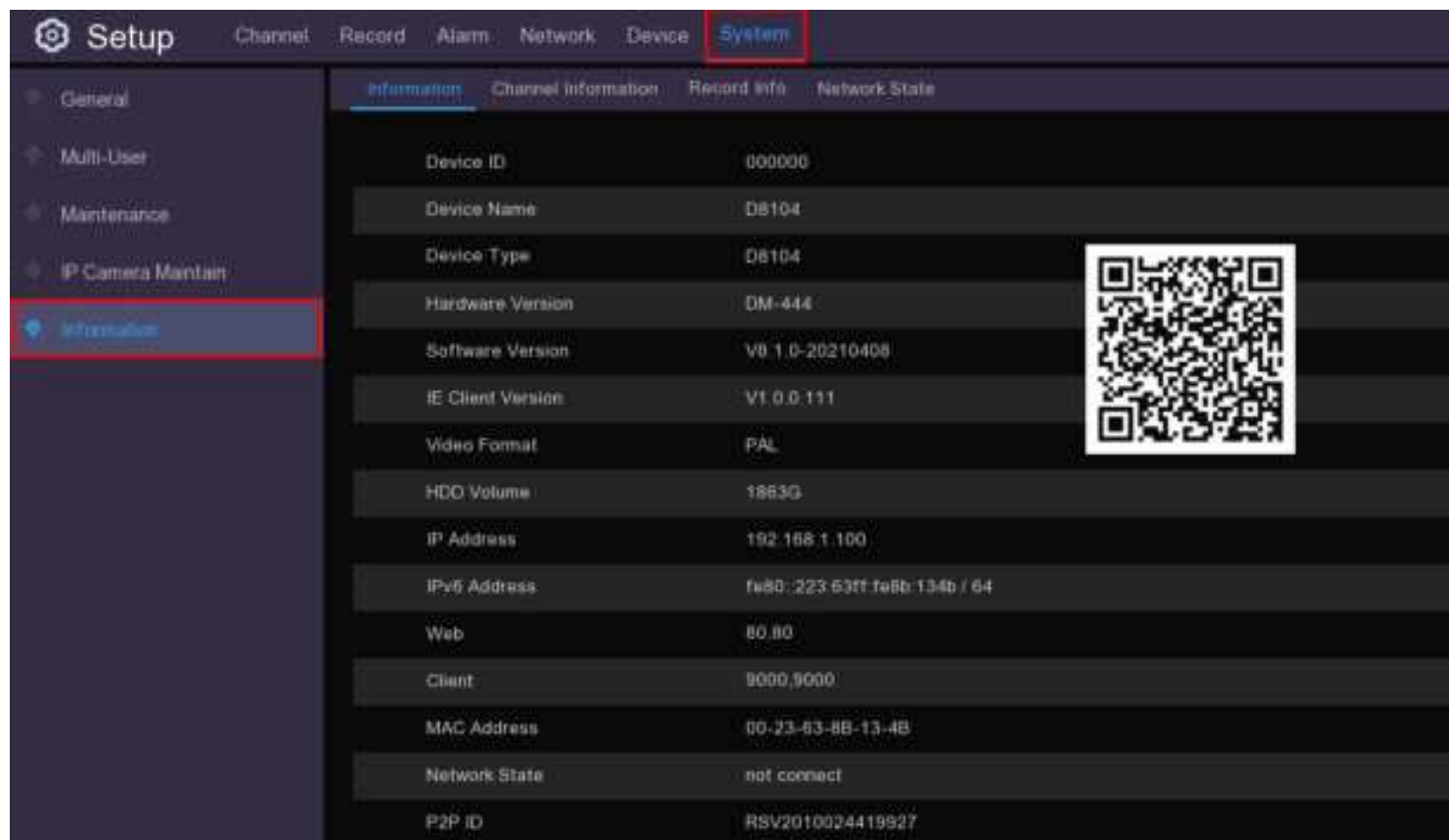

The screenshot shows the 'Setup' menu with 'System' selected. The 'Information' sub-menu is active, displaying various system parameters. A QR code is visible on the right side of the page, which is used for remote access via a mobile app. The P2P ID is also displayed at the bottom of the list.

Information	Channel Information	Record Info	Network State
Device ID		000000	
Device Name		DB104	
Device Type		DB104	
Hardware Version		DM-444	
Software Version		V8.1.0-20210408	
IE Client Version		V1.0.0.111	
Video Format		PAL	
HDD Volume		1863G	
IP Address		192.168.1.100	
IPv6 Address		fe80::223:63ff:fe8b:134b / 64	
Web		80.80	
Client		9000,9000	
MAC Address		00-23-63-8B-13-4B	
Network State		not connect	
P2P ID		RSV2010024419927	

Chapter 11 System

11.5.1 Channel Info



The screenshot shows the 'System' tab in the Setup menu. The 'Channel Information' sub-tab is active, displaying a table with the following data:

Channel	Alias	State	Mainstream	Substream	Addressable	Motion Detection	Privacy Zone
CH1	CH1	On-line	2560x1944, 15Fps, 4Mbps	640x 480, 15Fps, 1024Kbps	Non-support	Support	Support
CH2	CH2	On-line	3840x2160, 15Fps, 8Mbps	1280x 720, 15Fps, 512Kbps	640x 480, 10Fps, 128Kbps	Support	Support
CH3	CH3	On-line	3840x2160, 15Fps, 8Mbps	1920x1080, 15Fps, 128Kbps	640x 480, 10Fps, 128Kbps	Support	Support
CH4	CH4	On-line	3840x2160, 15Fps, 8Mbps	1920x1080, 15Fps, 512Kbps	640x 480, 10Fps, 128Kbps	Support	Support

View channel information for each connected camera such as alias, mainstream and substream recording specifications, motion detection status & privacy zone.

Chapter 11 System

11.5.3 Record Info

View recording information for each connected camera such as bitrate, stream type, recording resolution and frame rate (FPS).

11.5.4 Network State

This page gives you a summary of the network settings for your DVR.

CONCORD

www.concordconnect.com.au