



OPERATING INSTRUCTIONS

EN

Translation of the Original

MVP 030-3 DC

Diaphragm Pump

PFEIFFER  **VACUUM**

Copyright

This document is the intellectual property of Pfeiffer Vacuum and all contents of this document are protected by copyright. They may not be copied, altered, reproduced or published without the prior written permission of Pfeiffer Vacuum.

We reserve the right to make changes to the technical data and information in this document.

Table of contents

1	About this manual	7
1.1	Validity	7
	1.1.1 Applicable documents	7
	1.1.2 Variants	7
1.2	Target group	7
1.3	Conventions	7
	1.3.1 Instructions in the text	7
	1.3.2 Pictographs	8
	1.3.3 Product labels	8
	1.3.4 Abbreviations	8
2	Safety	10
2.1	General safety instructions	10
2.2	Safety instructions	10
2.3	Safety precautions	13
2.4	Product usage limits	13
2.5	Proper use	14
2.6	Foreseeable improper use	14
3	Product description	15
3.1	Product identification	15
3.2	Shipment	15
3.3	Function	15
4	Transportation and Storage	16
4.1	Transporting the vacuum pump	16
4.2	Storing the vacuum pump	16
5	Installation	17
5.1	Installing the vacuum pump	17
5.2	Connecting the vacuum side	17
5.3	Connecting the exhaust side	17
5.4	Interfaces	18
	5.4.1 Voltage supply	20
	5.4.2 Inputs	20
	5.4.3 Outputs	21
	5.4.4 RS-485 interface allocation	21
	5.4.5 Cross-linked via the RS-485 connection	22
	5.4.6 Connection options via interface RS-485	22
5.5	Pfeiffer Vacuum protocol for RS-485 interface	23
	5.5.1 Telegram frame	23
	5.5.2 Telegram description	23
	5.5.3 Telegram example 1	23
	5.5.4 Telegram example 2	24
	5.5.5 Data types	24
6	Operation	26
6.1	Putting the vacuum pump into operation	26
6.2	Operating modes	26
6.3	Switching on the vacuum pump	27
6.4	Operation with Pfeiffer Vacuum parameter set	27
	6.4.1 General	27
	6.4.2 Control commands	28
	6.4.3 Status requests	28
	6.4.4 Reference value inputs	29
	6.4.5 Configuring the connections with the PV parameter set	29
	6.4.6 Speed actuator operation	30

6.4.7	Standby mode	30
6.4.8	Normal operation	31
6.5	Operation monitoring	31
6.5.1	Operating mode display via LED	31
6.5.2	Temperature monitoring	31
6.6	Pumping condensable vapors	31
6.7	Switching off the vacuum pump	32
7	Maintenance	33
7.1	Maintenance instructions	33
7.2	Checklist for inspection and maintenance	33
7.3	Replace the diaphragms and valves	34
7.4	Check the ultimate pressure	38
8	Decommissioning	39
8.1	Decommissioning the vacuum pump for longer periods	39
8.2	Disposing of the vacuum pump	39
9	Malfunctions	40
9.1	General	40
9.2	Error codes	40
9.3	Warning and error messages when operating with DCU	40
10	Service solutions from Pfeiffer Vacuum	42
11	Spare parts packs	44
12	Accessories	45
13	Technical data and dimensions	46
13.1	General	46
13.2	Technical data	46
13.3	Substances in contact with the media	47
13.4	Dimensions	47
	Declaration of conformity	49

List of tables

Tbl. 1:	Product labels	8
Tbl. 2:	Abbreviations used in this document	9
Tbl. 3:	Usage limits of the vacuum pump	13
Tbl. 4:	Ambient conditions	17
Tbl. 5:	Connection plug arrangement Simple Pump Interface D-Sub-socket, 15-pin	18
Tbl. 6:	Definition of the RS-485 interface	21
Tbl. 7:	Factory setting of the electronic drive unit for diaphragm pumps when delivered	26
Tbl. 8:	Parameter set Control commands	28
Tbl. 9:	Parameter set Status requests	29
Tbl. 10:	Parameter set Reference value inputs	29
Tbl. 11:	Configuration with parameters [P:019] and [P:024]	30
Tbl. 12:	Configuration with parameters [P:060] and [P:061]	30
Tbl. 13:	Behavior and meaning of the LED of the electronic drive unit	31
Tbl. 14:	Maintenance intervals for diaphragm pumps	34
Tbl. 15:	Error messages for the vacuum pump	40
Tbl. 16:	Warning messages for the vacuum pump	40
Tbl. 17:	Warning and error messages when using a DCU	41
Tbl. 18:	Spare parts of the MVP 030-3 DC	44
Tbl. 19:	MVP 030-3 DC accessories	45
Tbl. 20:	Conversion table: Pressure units	46
Tbl. 21:	Conversion table: Units for gas throughput	46
Tbl. 22:	Technical data, MVP 030-3 DC	47
Tbl. 23:	Materials that make contact with the process media inside the diaphragm pump	47

List of figures

Fig. 1:	Design of the MVP 030-3 DC	15
Fig. 2:	Pin assignment of the D-Sub socket, 15-pin	18
Fig. 3:	Connection example: MVP 030-3 DC – DCU/TPS	19
Fig. 4:	Connection example: MVP 030-3 DC – HiPace/DCU/TPS	20
Fig. 5:	Networking via the RS-485 interface	22
Fig. 6:	Connection options via interface RS-485	22
Fig. 7:	Mounting the flushing gas nozzle	32
Fig. 8:	Dismantle the pump head and replace the valves	35
Fig. 9:	Replacing the diaphragms	36
Fig. 10:	Mounting the pump head	37
Fig. 11:	Spare parts of the MVP 030-3 DC	44
Fig. 12:	Dimension diagram of the MVP 030-3 DC (SPI)	48

1 About this manual



IMPORTANT

Read carefully before use.
Keep the manual for future consultation.

1.1 Validity

These operating instructions are for customers of Pfeiffer Vacuum. They describe the function of the designated product and provide the most important information for safe usage of the product. The descriptions comply with applicable directives. All information provided in these operating instructions refer to the current development status of the product. The documentation remains valid as long as the customer does not modify the product in any way.

1.1.1 Applicable documents

Designation	Document
Declaration of conformity	A component of these operating instructions

1.1.2 Variants

These instructions apply to diaphragm pumps of the DC series:

- MVP 030-3 DC as standard version
- MVP 030-3 DC in the version for the integration in a pumping station (without handle and rubber feet)

1.2 Target group

These operating instructions are aimed at all persons performing the following activities on the product:

- Transportation
- Setup (Installation)
- Usage and operation
- Decommissioning
- Maintenance and cleaning
- Storage or disposal

The work described in this document is only permitted to be performed by persons with the appropriate technical qualifications (expert personnel) or who have received the relevant training from Pfeiffer Vacuum.

1.3 Conventions

1.3.1 Instructions in the text

Usage instructions in the document follow a general structure that is complete in itself. The required action is indicated by an individual step or multi-part action steps.

Individual action step

A horizontal, solid triangle indicates the only step in an action.

- ▶ This is an individual action step.

Sequence of multi-part action steps

The numerical list indicates an action with multiple necessary steps.

1. Step 1
2. Step 2
3. ...

1.3.2 Pictographs

Pictographs used in the document indicate useful information.



Note



Tip

1.3.3 Product labels

This section describes all the labels on the product along with their meaning.

	<p>Rating plate</p> <p>The rating plate is located on the cover of the electronics.</p>
	<p>Warning of hot surfaces</p> <p>The label warns of hot surfaces during operation or immediately after switching off the vacuum pump.</p>
	<p>Closure seal</p> <p>The diaphragm heads are sealed at the factory. Damaging or removing a closure seal results in loss of the warranty.</p>

Tbl. 1: Product labels

1.3.4 Abbreviations

Abbreviation	Meaning in this document
DC	Direct current
DCU	Display Control Unit (Pfeiffer Vacuum display and control unit).
DN	Nominal diameter (from the French: diamètre nominal)
f	Rotation speed value of a vacuum pump (frequency, in rpm or Hz)
HPU	Handheld Programming Unit. Aid for control and monitoring of pump parameters
LED	Light emitting diode
MVP	Diaphragm vacuum pump
NN	Mean sea level
[P:xxx]	Electronic drive unit control parameters. Printed in bold as a three-digit number in square brackets. Frequently displayed in conjunction with a short description. Example: [P:312] software version

Abbreviation	Meaning in this document
PE	Earthed conductor (protective earth)
PWM	Pulse width modulation (Type of modulation where one technical variable (e.g. electrical voltage) changes between two values.)
SPI	Simple Pump Interface
T	Temperature (in °C), property abbreviation of the vacuum pump
TC	Turbopump electronic drive unit (turbo controller)
TPS	Voltage supply (turbo power supply)

Tbl. 2: Abbreviations used in this document

2 Safety

2.1 General safety instructions

This document includes the following four risk levels and one information level.

⚠ DANGER
<p>Imminent danger</p> <p>Indicates a hazardous situation which, if not avoided, will result in death or serious injury.</p> <ul style="list-style-type: none"> ▶ Instructions on avoiding the hazardous situation

⚠ WARNING
<p>Possibly imminent danger</p> <p>Indicates a hazardous situation which, if not avoided, could result in death or serious injury.</p> <ul style="list-style-type: none"> ▶ Instructions on avoiding the hazardous situation

⚠ CAUTION
<p>Possibly imminent danger</p> <p>Indicates a hazardous situation which, if not avoided, could result in minor or moderate injury.</p> <ul style="list-style-type: none"> ▶ Instructions on avoiding the hazardous situation

NOTICE
<p>Danger of property damage</p> <p>Notice is used to address practices not related to physical injury.</p> <ul style="list-style-type: none"> ▶ Instructions on avoiding property damage

i	Notes, tips or examples indicate important information on the product or on this document.
----------	--

2.2 Safety instructions

All safety instructions in this document are based on the results of the risk assessment carried out in accordance with Machinery Directive 2006/42/EC Annex I and EN ISO 12100 Section 5. As far as applicable, all unit life cycle phases have been considered.

Risks during transport

NOTICE
<p>Damage caused during transport</p> <p>Transport in unsuitable packaging can damage the product.</p> <ul style="list-style-type: none"> ▶ Observe the transport instructions. ▶ Always transport the vacuum pump in the original packaging or in a respective impact-proof packaging. ▶ Transport the vacuum pump using only the transport handles provided. ▶ Seal inlet and outlet ports with blind plugs or protective caps.

Risks during storage

NOTICE**Damage caused by improper storage**

Improper storage leads to damage to the vacuum pump.

- ▶ Store the vacuum pump in a cool, dry, dust-free place, where it is protected against impacts.
- ▶ Seal inlet and outlet ports (e.g. using transport caps).
- ▶ Maintain the permissible storage temperature. (See technical data)

Risks during installation

⚠ DANGER**Danger to life from electric shock**

When establishing the voltages that exceed the specified safety extra-low voltage (according to IEC 60449 and VDE 0100), the insulating measures will be destroyed. There is a danger to life from electric shock at the communication interfaces.

- ▶ Connect only suitable devices to the bus system.

⚠ CAUTION**Danger of injury from bursting as a result of high pressure in the exhaust line**

Faulty or inadequate exhaust pipes lead to dangerous situations, e.g. increased exhaust pressure. There is a danger of bursting. Injuries caused by flying fragments, the escaping of high pressure, and damage to the unit cannot be excluded.

- ▶ Route the exhaust line without shut-off units.
- ▶ Observe the permissible pressures and pressure differentials for the product.
- ▶ Check the function of the exhaust line on a regular basis.

NOTICE**Property damage on the electronics**

Separating all plug-and-socket connections within the bus system with voltage supply switched on may lead to the destruction of electronic components.

- ▶ Always disconnect the voltage supply before removing the connecting plug.
- ▶ After switching off the power supply pack, wait until the residual load has dispersed completely before disconnecting the plug-and-socket connection.

Risks during operation

⚠ WARNING**Danger of poisoning due to toxic process media escaping from the exhaust pipe**

During operation with no exhaust line, the vacuum pump allows exhaust gases and vapors to escape freely into the air. There is a risk of injury and fatality due to poisoning in processes with toxic process media.

- ▶ Observe the pertinent regulations for handling toxic process media.
- ▶ Safely purge toxic process media via an exhaust line.
- ▶ Use appropriate filter equipment to separate toxic process media.

⚠ WARNING**Risk of explosion from reactive, explosive or other hazardous gas / air mixtures.**

Uncontrolled inlet of gas at the flushing gas nozzle leads to sparks generated mechanically following diaphragm rupture, hot surfaces or to explosive gas / air mixtures in the vacuum system caused by static electricity.

- ▶ If necessary, use inert gas for supplying the flushing gas in order to avoid a potential ignition.

⚠ CAUTION

Danger of burns on hot surfaces

Depending on the operating and ambient conditions, the surface temperature of the vacuum pump can increase to above 70 °C.

- ▶ Provide suitable touch protection.

⚠ CAUTION

Risk of poisoning due to toxic process gases escaping

For intake pressures > 500 hPa, process gas may escape from the flushing gas nozzle.

- ▶ If necessary, use an extraction line.

NOTICE

Vacuum pump damage caused by overpressure

Mixing up the connections causes overpressure overload. The vacuum pump can be started only against max. 1 bar differential pressure between inlet and outlet; otherwise the motor jams and sustains damage.

- ▶ Make sure that the distributor is installed correctly on the diaphragm heads, before connecting the vacuum pump to the vacuum equipment.
- ▶ Before commissioning, make completely sure that the pressure side pressure is below the permissible limit.

Risks during maintenance, decommissioning and in event of malfunctions

⚠ WARNING

Health hazard through poisoning from toxic contaminated components or devices

Toxic process media result in contamination of devices or parts of them. During maintenance work, there is a risk to health from contact with these poisonous substances. Illegal disposal of toxic substances causes environmental damage.

- ▶ Take suitable safety precautions and prevent health hazards or environmental pollution by toxic process media.
- ▶ Decontaminate affected parts before carrying out maintenance work.
- ▶ Wear protective equipment.

⚠ CAUTION

Danger of injury from moving parts

After a power failure or a standstill as a result of overheating, the motor restarts automatically. There is a risk of injury to fingers and hands if they enter the operating range of rotating parts.

- ▶ Safely disconnect motor from the mains.
- ▶ Secure the motor against reactivation.
- ▶ Dismantle the vacuum pump for inspection, away from the system if necessary.

⚠ CAUTION

Danger of burns on hot surfaces

In the event of a fault, the surface temperature of the vacuum pump can increase to above 105 °C.

- ▶ Allow the vacuum pump to cool down before carrying out any work.
- ▶ Wear personal protective equipment if necessary.

NOTICE

Property damage from incorrect installation

Changed dead volume from incorrect installation of the original spacer disks worsens the final vacuum or leads to bearing damage.

- ▶ During disassembly, keep the existing spacer disks separate per installation location.
- ▶ Reinstall the original spacer disks back in-between the supporting washer and connection rod.

NOTICE**Danger of property damage from improper maintenance**

Unprofessional work on the vacuum pump will lead to damage for which Pfeiffer Vacuum accepts no liability.

- ▶ We recommend taking advantage of our service training offering.
- ▶ When ordering spare parts, specify the information on the nameplate.

2.3 Safety precautions

**Duty to provide information on potential dangers**

The product holder or user is obliged to make all operating personnel aware of dangers posed by this product.

Every person who is involved in the installation, operation or maintenance of the product must read, understand and adhere to the safety-related parts of this document.

**Infringement of conformity due to modifications to the product**

The Declaration of Conformity from the manufacturer is no longer valid if the operator changes the original product or installs additional equipment.

- Following the installation into a system, the operator is required to check and re-evaluate the conformity of the overall system in the context of the relevant European Directives, before commissioning that system.

General safety precautions when handling the product

- ▶ Observe that the **current supply** of the vacuum pump must meet the requirements for double isolation between mains input voltage and operating voltage, as per IEC 61010 and IEC 60950. Pfeiffer Vacuum recommends that only original power supply packs are used.
Pfeiffer Vacuum guarantees compliance with the requirements of European and North American guidelines only in this case.
- ▶ Prevent process gases and their reaction and ancillary products that are harmful to health and the environmental from escaping, or dispose of these according to the applicable regulations.
- ▶ Avoid contact with process gases that are harmful to health and if required, wear personal protective clothing.
- ▶ Check the media compatibility of parts carrying media.
- ▶ Observe all applicable safety and accident prevention regulations.
- ▶ Check that all safety measures are observed at regular intervals.
- ▶ Do not expose body parts to the vacuum.
- ▶ Never disconnect plug connections during operation.
- ▶ Never fill or operate the unit with cleaning agents or cleaning agent residues.
- ▶ Do not carry out your own conversions or modifications on the unit.
- ▶ Observe the unit protection class prior to installation or operation in other environments.
- ▶ Provide suitable touch protection, if the surface temperature exceeds 70 °C.
- ▶ Keep lines and cables away from hot surfaces (> 70 °C).
- ▶ Before returning the vacuum pump, observe the notes in the chapter Service solutions. .

2.4 Product usage limits

Operations condition, status	Intake pressure	Permissible intake temperature of medium to be pumped
Continuous operation	> 100 hPa (high gas load)	+10 °C to +40 °C
Continuous operation	< 100 hPa (low gas load)	0 °C to +60 °C
short-term (< 5 minutes)	< 100 hPa (low gas load)	-10 °C to +80 °C

Tbl. 3: Usage limits of the vacuum pump

2.5 Proper use

- The vacuum pump may only be used for vacuum generation.
- It is not permissible to operate the vacuum pump with accessories not recommended by Pfeiffer Vacuum.
- Always observe installation, commissioning, operating, and maintenance instructions.

2.6 Foreseeable improper use

Improper use of the product invalidates all warranty and liability claims. Improper use is any, even unintended, use, which is contrary to the product purpose; and in particular:

- Pumping of corrosive media
- Pumping explosive media
- Pumping corrosive, explosive, radioactive, or volatile media
- Pumping of gases that introduce an ignition source to the suction chamber
- Pumping of gases that contain impurities such as particles, dust, or condensate
- Pumping of fluids
- Pumping FPM-solubilizing media
- Pumping vapors from combustible liquids
- Pumping pressurized media (> atmospheric pressure)
- Pumping media that can condense or cause adhering deposits to form in the suction chamber
- Use of the vacuum pump outside the specified area of application
- Using the vacuum pump below ground
- Using the vacuum pump to generate pressure
- Using the vacuum pump in systems in which sporadic loads and vibrations or periodic forces act on the unit
- Using the vacuum pump in strong electrical, magnetic, or electromagnetic fields
- Connection to vacuum pumps or equipment which are not suitable for this purpose according to their operating instructions
- Connection to devices with exposed live parts
- Connecting to sockets without earthing contact
- Using lubricants not specified by Pfeiffer Vacuum
- Using pipes to lift the vacuum pump
- Use of accessories or spare parts that are not listed in these instructions
- Using the vacuum pump as a climbing aid
- Using the connection lines between the diaphragm heads as carrying handles
- Using the vacuum pump in ambient conditions that do not meet the specified IP protection class limits

3 Product description

3.1 Product identification

To ensure for a clear identification of the product when communicating with Pfeiffer Vacuum, always keep all of the information on the rating plate to hand.

The following information is shown on the rating plate:

- Pump model
- Model number
- Date of manufacture

Certification

Certification can be identified on a test seal on the vacuum pump. Respective information for this can be found online at:

- www.tuvdotcom.com
- with the company ID no. 000021320

3.2 Shipment

- Vacuum pump with drive
- Silencer
- Operating instructions
- Blind plug on the vacuum connection

3.3 Function

The diaphragm pump of the MVP 030-3 DC series is a dry compressing vacuum pump with 3 pumping stages. The vacuum pump is a positive displacement pump with a periodic change in suction chamber size, produced by the movement of the diaphragm. The gas flow causes the valves to open and close automatically. The pump units are directly connected to the drive motor.

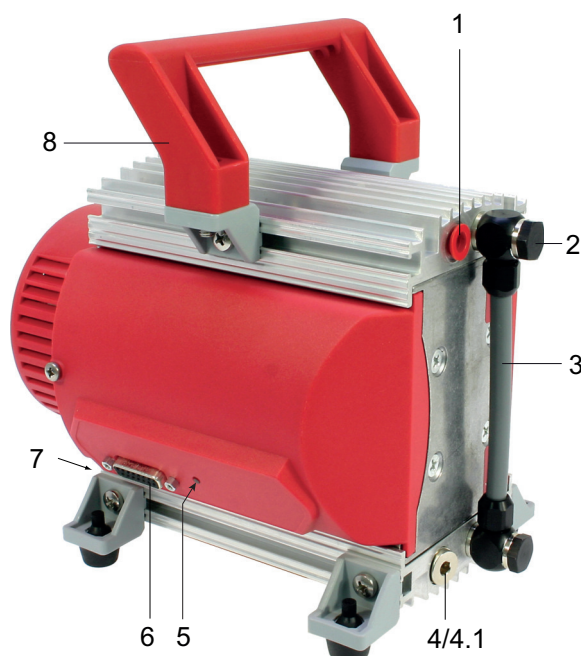

Fig. 1: Design of the MVP 030-3 DC

- | | | | |
|-----|--------------------------------|---|-----------------------|
| 1 | Vacuum connection, G 1/8" | 5 | LED |
| 2 | Banjo bolt | 6 | Connecting socket |
| 3 | Interhead connection | 7 | Exhaust with silencer |
| 4 | Locking screw | 8 | Retainer |
| 4.1 | Flushing gas nozzle (optional) | | |

4 Transportation and Storage

4.1 Transporting the vacuum pump



Pfeiffer Vacuum recommends keeping the transport packaging and original protective cover.

Procedure

In order to prevent dirt and foreign matter from entering the pump interior, it is important that the protective cap is kept on the vacuum connection during transport.

1. Unpack the vacuum pump.
2. Lift the vacuum pump out of the transport packaging by hand using the handle.
3. Make sure that no forces are acting on the piping system.

4.2 Storing the vacuum pump



Pfeiffer Vacuum recommends storing the products in their original transport packaging.

Procedure

1. Seal the vacuum connection with the blind plug.
2. Store the vacuum pump only in dry, dust-free rooms, within the specified ambient conditions.
3. Hermetically shrink-wrap the vacuum pump together with a drying agent in a plastic bag if the vacuum pump is to be stored in areas with damp or aggressive atmospheres.

5 Installation

5.1 Installing the vacuum pump

Installation location	Inside, protected against the accumulation of dust and weather influences
Protection category	IP 20
Installation altitude	max. 2000 m above sea level, at an installation location above 1000 meters above sea level, there is a risk of insufficient cooling. if necessary, take measures according to Directive DIN EN 61010.
Ambient temperature	+12 °C to +40 °C
Relative air humidity	80% at T ≤ 31 °C, to max. 50% at T ≤ 40 °C
Degree of contamination	2
Excess voltage category	II

Tbl. 4: Ambient conditions

Procedure

1. Place the vacuum pump on a flat, horizontal surface.
2. For stationary installation, screw the vacuum pump direct to the mounting surface if necessary.
 - For this purpose, dismantle the rubber feet.
3. When installing the pump in a closed housing, ensure adequate air circulation.
 - The vacuum pump does not have a fan.
4. Keep the specifications on the motor rating plate visible and freely accessible.

5.2 Connecting the vacuum side



Preventing pressure losses

Using the shortest possible vacuum connection lines with large nominal diameter prevents pressure losses.



Condensate separator

Pfeiffer Vacuum recommends the installation of a condensate separator in case vapors are formed from moisture during evacuation.

Procedure

1. Remove the locking cap from the vacuum connection.
2. Install the connection between vacuum pump and vacuum system so that it is as short as possible.
3. Install a condensate separator upstream of the vacuum pump.
4. Connect the vacuum pump to the vacuum system using the vacuum connection.

5.3 Connecting the exhaust side

⚠ CAUTION

Danger of injury from bursting as a result of high pressure in the exhaust line

Faulty or inadequate exhaust pipes lead to dangerous situations, e.g. increased exhaust pressure. There is a danger of bursting. Injuries caused by flying fragments, the escaping of high pressure, and damage to the unit cannot be excluded.

- ▶ Route the exhaust line without shut-off units.
- ▶ Observe the permissible pressures and pressure differentials for the product.
- ▶ Check the function of the exhaust line on a regular basis.

Procedure

The silencer is mounted as standard. With higher gas throughput, an optional exhaust line can be mounted.

1. Check the installed silencer for free passage.
2. Choose a minimum exhaust line cross section equal to the connection nominal diameter.
3. Depending on the pump type, use metallic hoses or PVC hoses with flange connections.
4. Route the piping downwards from the vacuum pump, to prevent condensate return.
5. Support or suspend the piping to the vacuum pump so that no piping system forces act on the vacuum pump.

5.4 Interfaces

NOTICE

Property damage on the electronics

Separating all plug-and-socket connections within the bus system with voltage supply switched on may lead to the destruction of electronic components.

- ▶ Always disconnect the voltage supply before removing the connecting plug.
- ▶ After switching off the power supply pack, wait until the residual load has dispersed completely before disconnecting the plug-and-socket connection.

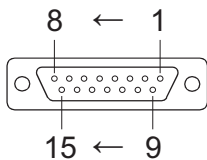

Fig. 2: Pin assignment of the D-Sub socket, 15-pin

Pin	Function	Description, factory setting
1	+24 VDC input	Voltage supply for drive and interface
2	DI access request	V+: Control via DIs, --> GND/open: Control unlocked
3	DI1	V+: Rotation speed setting mode, --> GND/open: no rotation speed setting mode
4	n.c.	
5	DI pumping station	V+: Vacuum pump on, --> GND/open: Vacuum pump off
6	DI standby	V+: standby, --> GND/open: no standby
7	V+	24 V output
8	DO1	GND: Error, V+: no error
9	DO2	GND: Vacuum pump off, V+: Vacuum pump on
10	n.c.	
11	n.c.	
12	n.c.	
13	RS-485	D+
14	RS-485	D-
15	Earth (GND)	Body contact of the voltage supply; reference earth for all digital inputs and outputs

Tbl. 5: Connection plug arrangement Simple Pump Interface D-Sub-socket, 15-pin

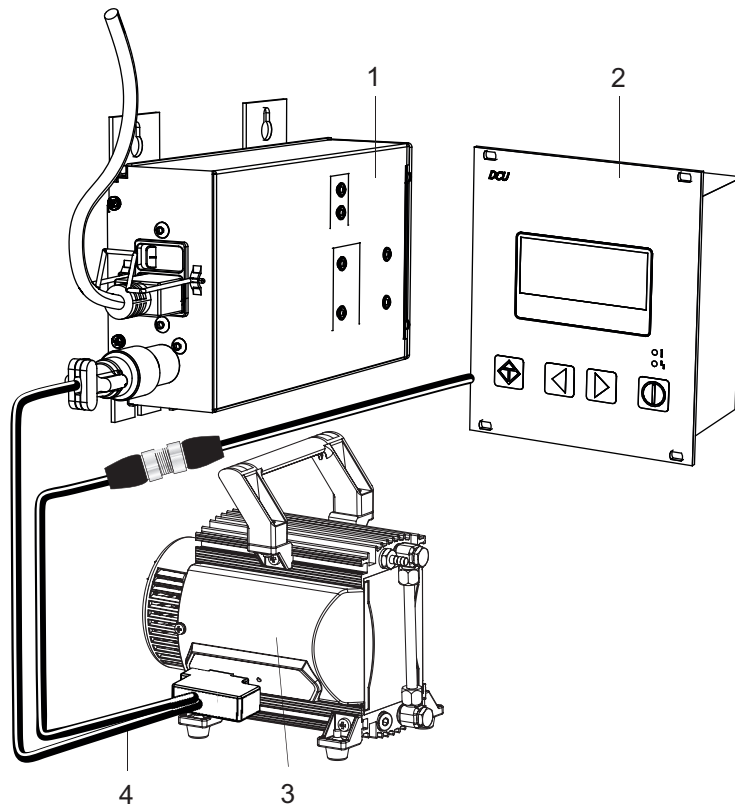

Fig. 3: Connection example: MVP 030-3 DC – DCU/TPS

- | | | | |
|---|---------|---|---|
| 1 | TPS | 3 | MVP |
| 2 | DCU/HPU | 4 | Connecting cable, order number: PM 061 350 -T |

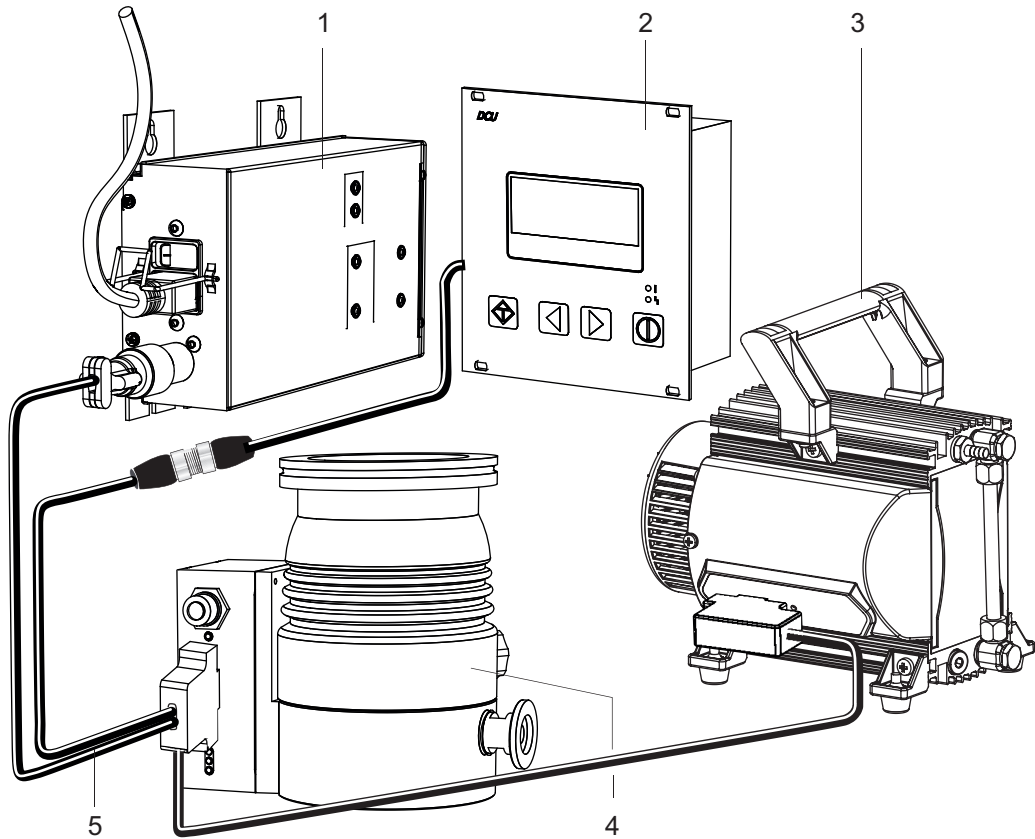

Fig. 4: Connection example: MVP 030-3 DC – HiPace/DCU/TPS

- | | |
|-----------|---|
| 1 TPS | 4 Turbopumpe HiPace |
| 2 DCU/HPU | 5 Connecting cable, order number: PE 100 013 -T |
| 3 MVP | |

5.4.1 Voltage supply

24 V DC input: The voltage supply is carried out using a connecting cable from the Pfeiffer Vacuum accessories or using a cable provided by the customer.

- Pin 1: +24 V DC
- Pin 15: Earth (GND)

24 V DC output / pin 7: Inputs 2 to 6 are activated if they are connected to pin 7 (active high) with +24 VDC. They can also be activated via an external SPS. The functions are deactivated by "SPS high level" and by "SPS low level".

- PLC High level: +13 V to +33 V
- PLC High level: -33 V to +7 V
- Ri: 7 kΩ
- I_{max} < 200 mA

5.4.2 Inputs

The digital inputs serve the switching of different functions of the electronic drive unit:

DI (remote priority)/pin 2

V+: The connection has an operating supremacy before all other digital inputs.

open: Remote priority "inactive"

DI1 (rotation speed setting mode)/pin 3

V+: Rotation speed setting mode "active"

open: Rotation speed setting mode "inactive"

DI vacuum pump/pin 5

The vacuum pump is switched on

V+: Vacuum pump on
 open: Vacuum pump off

DI Standby

The stand-by speed can be selected in the range **30 to 100%** of the nominal speed.

V+: Standby activated (rotation speed setting mode is "inactive")

GND/open: Standby off, operation at nominal rotation speed

5.4.3 Outputs

The digital outputs on 15-pin D-Sub connection can be loaded with maximum 24 V/50 mA per output. All outputs listed below are configurable with the Pfeiffer Vacuum parameter set via the RS-485 interface (description relates to factory settings).

DO1 (error)/pin 8

After applying the voltage supply, the digital output DO1 permanently outputs V+ meaning which means "no error". "Active low" means error (common error message).

V+: no error

GND: Defect

DO2 (set rotation speed)/pin 9

"Active high" means "Set rotation speed reached". The signal can, for example, be used for a "Vacuum pump ready for operation" message.

V+: Target speed reached

GND: Set rotation speed not reached

5.4.4 RS-485 interface allocation

⚠ DANGER

Danger to life from electric shock

When establishing the voltages that exceed the specified safety extra-low voltage (according to IEC 60449 and VDE 0100), the insulating measures will be destroyed. There is a danger to life from electric shock at the communication interfaces.

- ▶ Connect only suitable devices to the bus system.

The connection of a Pfeiffer Vacuum display and control panel (DCU or HPU) or an external PC is possible at pin 13 and pin 14 respectively.

- One external control unit each can be connected at the RS-485 interface.
- The group address of the electronic drive unit is 902.
- All devices connected to the bus must have different RS-485 device addresses **[P:797]**.
- A USB interface (PC) can be connected via the USB/RS-485-converter.

Designation	Value
Serial interface	RS-485
Baudrate	9600 Baud
Data word length	8 bit
Parity	none (no parity)
Start bits	1
Stop bits	1

Tbl. 6: Definition of the RS-485 interface

5.4.5 Cross-linked via the RS-485 connection

⚠ DANGER

Danger to life from electric shock

When establishing the voltages that exceed the specified safety extra-low voltage (according to IEC 60449 and VDE 0100), the insulating measures will be destroyed. There is a danger to life from electric shock at the communication interfaces.

- ▶ Connect only suitable devices to the bus system.

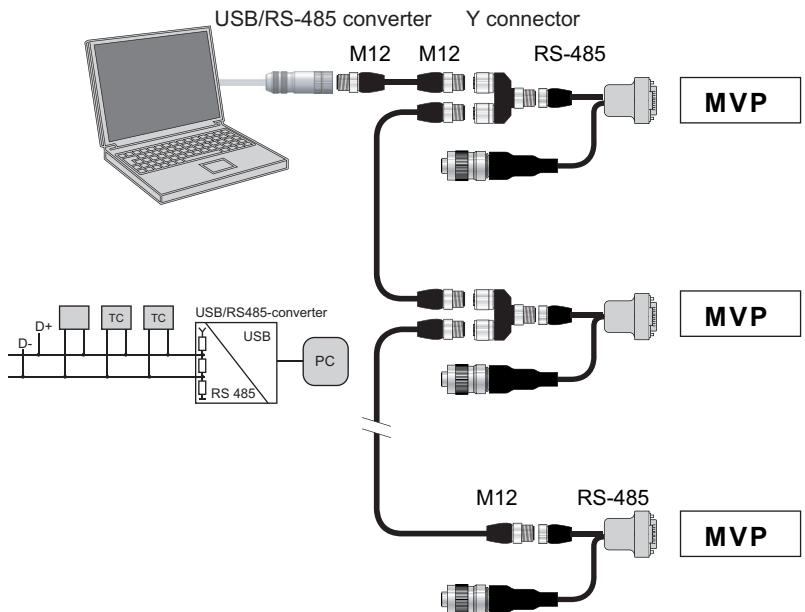

Fig. 5: Networking via the RS-485 interface

5.4.6 Connection options via interface RS-485

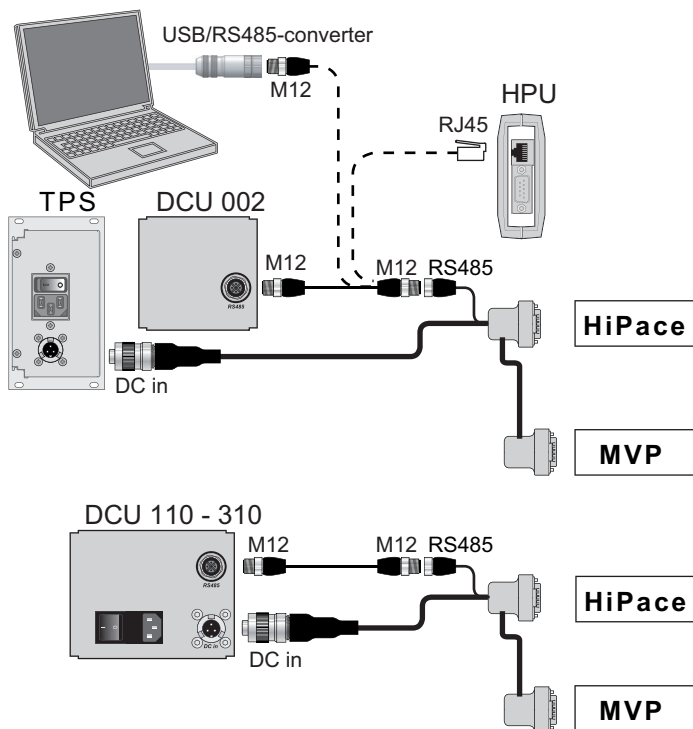

Fig. 6: Connection options via interface RS-485



Connecting Pfeiffer Vacuum display and control panels or PC

At interface RS-485, one external control panel can be connected in each case.

1. Use the respective connection cable supplied with the control panel or from the range of accessories.
2. Use the option to connect a PC via the USB/RS-485 converter.

5.5 Pfeiffer Vacuum protocol for RS-485 interface

5.5.1 Telegram frame

The telegram frame of the Pfeiffer Vacuum protocol contains only ASCII code characters [32; 127], the exception being the end character of the telegram C_R . Basically, a master  (e.g. a PC) sends a telegram, which is answered by a slave  (e.g. electronic drive unit or transmitter).

a2	a1	a0	*	0	n2	n1	n0	l1	l0	dn	...	d0	c2	c1	c0	C_R
a2 – a0				Unit address for slave 												
				<ul style="list-style-type: none"> • Individual address of the unit ["001";"255"] • Group address "9xx" for all identical units (no response) • global address "000" for all units on the bus (no response) 												
*				Action according to telegram description												
n2 – n0				Pfeiffer Vacuum parameter numbers												
l1 – l0				Data length dn to d0												
dn – d0				Data in the respective data type (see chapter "Data types", page 24).												
c2 – c0				Checksum (sum of ASCII values of cells a2 to d0) modulo 256												
C_R				carriage return (ASCII 13)												

5.5.2 Telegram description

Data query  -->  ?

a2	a1	a0	0	0	n2	n1	n0	0	2	=	?	c2	c1	c0	C_R
----	----	----	---	---	----	----	----	---	---	---	---	----	----	----	-------

Control command  -->  !

a2	a1	a0	1	0	n2	n1	n0	l1	l0	dn	...	d0	c2	c1	c0	C_R
----	----	----	---	---	----	----	----	----	----	----	-----	----	----	----	----	-------

Data response / Control command understood  --> 

a2	a1	a0	1	0	n2	n1	n0	l1	l0	dn	...	d0	c2	c1	c0	C_R
----	----	----	---	---	----	----	----	----	----	----	-----	----	----	----	----	-------

Error message  --> 

a2	a1	a0	1	0	n2	n1	n0	0	6	N	O	_	D	E	F	c2	c1	c0	C_R	
											_	R	A	N	G	E				
											_	L	O	G	I	C				

- NO_DEF Parameter number n2–n0 no longer exists
- _RANGE Data dn–d0 outside the permissible range
- _LOGIC Logical access error

5.5.3 Telegram example 1

Data query

Current rotation speed (parameter [P:309], device address slave: "123")

☐ --> ○ ?	1	2	3	0	0	3	0	9	0	2	=	?	1	1	2	C _R
ASCII	49	50	51	48	48	51	48	57	48	50	61	63	49	49	50	13

Data response: 633 Hz

Current rotation speed (parameter [P:309], device address Slave: "123")

○ --> ☐	1	2	3	1	0	3	0	9	0	6	0	0	0	6	3	3	0	3	7	C _R
ASCII	49	50	51	49	48	51	48	57	48	54	48	48	48	54	51	51	48	51	55	13

5.5.4 Telegram example 2

Control command

Switch on the pumping station (parameter [P:010], device address Slave: "042")

☐ --> ○ !	0	4	2	1	0	0	1	0	0	6	1	1	1	1	1	1	0	2	0	C _R
ASCII	48	52	50	49	48	48	49	48	48	54	49	49	49	49	49	49	48	50	48	13

Control command understood

Switch on the pumping station (parameter [P:010], device address Slave: "042")

○ --> ☐	0	4	2	1	0	0	1	0	0	6	1	1	1	1	1	1	0	2	0	C _R
ASCII	48	52	50	49	48	48	49	48	48	54	49	49	49	49	49	49	48	50	48	13

5.5.5 Data types

No.	Data type	Description	Length I1 – I0	Example
0	boolean_old	Logical value (false/true)	06	000000 corresponds with false 111111 corresponds with true
1	u_integer	Positive whole number	06	000000 to 999999
2	u_real	Positive fixed point number	06	001571 corresponds with 15.71
3	u_expo	Positive exponential number	06	1.2E-2 corresponds with $1,2 \cdot 10^{-2}$ 005E8 corresponds with $5 \cdot 10^8$
4	string	Any character string with 6 characters. ASCII codes between 32 and 127	06	TC_110, TM_700
6	boolean_new	Logical value (false/true)	01	0 corresponds with false 1 corresponds with true
7	u_short_int	Positive whole number	03	000 to 999
10	u_expo_new	Positive exponential number. The last of both digits are the exponent with a deduction of 20.	06	100023 corresponds with $1,0 \cdot 10^3$ 100000 corresponds with $1,0 \cdot 10^{-20}$

No.	Data type	Description	Length l1 – l0	Example
11	string16	Any character string with 16 characters. ASCII codes between 32 and 127	16	this-is-an-example
12	string8	Any character string with 8 characters. ASCII codes between 32 and 127	08	Example

6 Operation

6.1 Putting the vacuum pump into operation

Important settings and function-related variables are factory-programmed into the vacuum pump electronic drive unit as parameters. Each parameter has a three-digit number and a description. Parameter-driven operation and control is supported via Pfeiffer Vacuum displays and control units, or externally via RS-485 using Pfeiffer Vacuum protocol.

WARNING

Danger of poisoning due to toxic process media escaping from the exhaust pipe

During operation with no exhaust line, the vacuum pump allows exhaust gases and vapors to escape freely into the air. There is a risk of injury and fatality due to poisoning in processes with toxic process media.

- ▶ Observe the pertinent regulations for handling toxic process media.
- ▶ Safely purge toxic process media via an exhaust line.
- ▶ Use appropriate filter equipment to separate toxic process media.

NOTICE

Vacuum pump damage caused by overpressure

Mixing up the connections causes overpressure overload. The vacuum pump can be started only against max. 1 bar differential pressure between inlet and outlet; otherwise the motor jams and sustains damage.

- ▶ Make sure that the distributor is installed correctly on the diaphragm heads, before connecting the vacuum pump to the vacuum equipment.
- ▶ Before commissioning, make completely sure that the pressure side pressure is below the permissible limit.

Parameter	Name	Designation	Adjustment, setting
[P:707]	SpdSVal	Speed-control operation specification	75 %

Tbl. 7: Factory setting of the electronic drive unit for diaphragm pumps when delivered

Procedure

1. Compare the frequency specifications on the rating plate with the available supply voltage.
2. Adequately protect the vacuum pump from sucking in impurities through appropriate measures (e.g. dust filter).
3. Check the exhaust connection for free passage (max. permissible pressure: 1100 hPa absolute).
4. Actuate the shut-off units so that the shut-off units open before or at the same time as the pump starts up.

6.2 Operating modes

The following operating modes are possible:

- Operation without control unit
- Operation via an external control unit
- Operation via RS-485 and Pfeiffer Vacuum display and control unit or PC



Automatic start

After bypassing the contacts at pins 2, 7, 5 on the connecting plug or when using a connecting cable with respective bridges and applying the supply voltage, the vacuum pump starts up immediately.

Pfeiffer Vacuum therefore recommends switching on the voltage supply immediately before operation.

Operation without control unit

1. Connect the respective connecting cable with bridges to the connecting plug.
2. Provide the current supply for the power supply pack.
3. Switch on the power supply pack with switch S1.

After applying the operating voltage, the vacuum pump carries out a self-test to check the supply voltage. After a successfully completed self-test, the vacuum pump starts.

Operation via an external control unit

- ▶ Connect the remote control via the 15-pin D-Sub socket.

The control is carried out by means of "PLC level".

Operation with the peripheral devices DCU or HPU

1. Connect the respective peripheral device to the 15-pin D-Sub socket.
2. Switch on the power supply pack with switch S1 or on the peripheral device.
3. Make the desired settings via the RS-485 using the peripheral device.



Observe the following documents when operating with a Pfeiffer Vacuum display and control panel in the [DownloadCenter](#).

- Operating manual "DCU" (PT0250)
- Operating manual "HPU" (PT0101)

6.3 Switching on the vacuum pump

The vacuum pump can be switched on in each pressure range, between atmospheric pressure and ultimate pressure.

When pumping down dry gases, no special precautions are required.

CAUTION

Danger of burns on hot surfaces

Depending on the operating and ambient conditions, the surface temperature of the vacuum pump can increase to above 70 °C.

- ▶ Provide suitable touch protection.

Switching on the vacuum pump

Once all necessary cable connections have been established, the following options are available for switching on the pump:

- using a mains switch on the power supply pack with respective bridges on the 15-pin D-Sub socket
 - via the peripheral devices DCU/HPU
 - using the PLC control unit on the 15-pin D-Sub socket
- ▶ Allow the vacuum pump to warm up prior to process start, with the vacuum flange closed.
 - The running warm time depends on the ambient temperature and may take between 15 and 30 minutes.

The vacuum pump achieves the specified throughput and ultimate pressure values once the operating temperature has been reached.

6.4 Operation with Pfeiffer Vacuum parameter set

6.4.1 General

All variables of the vacuum pump relevant for the function are stored as parameters in the electronic drive unit. Each parameter has a three-digit number and a description. Parameters can be used via Pfeiffer Vacuum display and control panels or via RS-485 with the Pfeiffer Vacuum protocol.

Conventions

Parameters are printed in bold as **three-digit numbers in square brackets**. The designation can also be specified.

Example: **[P:312] Software version**

Factory settings

The electronic drive unit is pre-programmed in the factory. This makes a more direct and safe operation of the vacuum pump possible without additional configuration.

You can configure the following parameters for the specific process:

- **[P:026]**: rotation speed setting mode on/off.
- **[P:707]**: specification of the rotation speed setting mode with 25 to 134% of the nominal rotation speed.
- **[P:002]**: stand-by mode on/off.

6.4.2 Control commands

#	Display	Designations	Functions	Data type	Access type	Unit	min.	max.	de-fault	can be stored
002	Standby	Standby	0 = off 1 = on	0	RW		0	1	0	x
010	Pumpg-Statn	Pump	0 = off 1 = on	0	RW		0	1	0	x
019	Cfg DO2	Configuration output DO2	1 = No error 2 = Error 5 = Set rotation speed reached 6 = Pump on 9 = "0" 10 = "1" 11 = Remote priority active	7	RW		0	20	6	x
024	Cfg DO1	Configuration output DO1	Settings, see [P:019]	7	RW		0	20	1	x
026	SpdSet-Mode	Speed actual operation	0 = off 1 = on	7	RW		0	1	0	x
060	CtrlVialnt	Operation of the interface	1 = remote 2 = RS-485 4 = PV.can 32 = Keys on the front panel 255 = Interface selection	7	RW		1	255	1	x
061	IntSelLckd	Interface selection locked	0 = off 1 = on	0	RW		0	1	0	x

Tbl. 8: Parameter set | Control commands

6.4.3 Status requests

#	Display	Designations	Functions	Data type	Access type	Unit	min.	max.	de-fault	can be stored
303	Error code	Error code		4	R					
309	ActualSpd	Actual rotational speed (Hz)		1	R	Hz				

#	Display	Designations	Functions	Data type	Access type	Unit	min.	max.	de-fault	can be stored
310	DrvCurrent	Drive current		2	R	A	0	9999.99		
311	OpHrsPump	Pump operating hours		1	R	h				x
312	Fw version	Software version interface circuit board		4	R					
313	DrvVoltage	Supply voltage	Voltage in x.xx V	2	R	R				
315	Nominal Spd	Nominal rotational speed (Hz)		1	R	Hz				
316	DrvPower	Drive power	Output in xW	1	R	W				
330	TempPump	Pump temperature		1	R	°C	0	999999		
349	ElecName	Device name designation		4	R					
352	FWVERSDRV	Firmware of the FC		4	R					
354	HW Version	Hardware version interface circuit board		4	R					
398	ActualSpd	Actual speed (rpm)		1	R	rpm				
399	NominalSpd	Nominal rotation speed (rpm)		1	R	rpm				

Tbl. 9: Parameter set | Status requests

6.4.4 Reference value inputs

#	Display	Designations	Functions	Data type	Access type	Unit	min.	max.	de-fault	can be stored
707	SpdSVal	Setpoint in speed-control operation	Set rotation speed in x.x% of the nominal rotation speed	2	RW	%	25	170	75	x
717	StdbySVal	Rotational speed setpoint in standby operation		2	RW	%	30	100	66.7	x
797	RS485Adr	RS-485 Interface address		1	RW		1	255	1	x

Tbl. 10: Parameter set | Reference value inputs

6.4.5 Configuring the connections with the PV parameter set

The electronic drive unit is pre-configured with the factory default basic functions and is ready for operation. For individual requirements, you can configure most connections for the electronic drive unit with the parameter set.

Configure the digital outputs

- Perform the configuration as per the following table:

Option	Description
1 = No error	active, with trouble-free operation
2 = Error	active, if the error message is active
5 = Set rotation speed reached	active, once the set rotation speed is reached
6 = Pump on	active, if pump on, motor on and no error
9 = always 0	GND for the control of an external device
10 = always 1	V+ for the control of an external device
11 = Remote	active, if the remote priority is active

Tbl. 11: Configuration with parameters [P:019] and [P:024]

Configure the interface

► Perform the configuration as per the following table:

Option [P:060]	Description
1 = remote	Operation via connection "remote"
2 = RS-485	Operation via connection "RS-485"
4 = PV.can	For service purposes only
32 = Keys on the front panel	Manual operation
Option [P:061]	
0 = off	Interface selection can be set via [P:060].
1 = on	Interface selection locked

Tbl. 12: Configuration with parameters [P:060] and [P:061]

6.4.6 Speed actuator operation

The set rotation speed is selected via the parameter [P:707] in the range **30 to 134%** of the set rotation speed. If the speed is higher than the set rotation speed (> 100%), an increased pump wear is possible. The rotation speed setting mode has priority over the stand-by mode.



Permissible rotation speed range of the vacuum pump

Parameterization in rotation speed setting mode is subject to the permissible rotation speed range of the respective vacuum pump. The electronic drive unit regulates automatically to the next valid value.

Set the rotation speed setting mode

1. Set the parameter [P:707] to the required value in %.
2. Set the parameter [P:026] to "1".
3. Check the set rotation speed (parameter [P:308] or [P:397]).

6.4.7 Standby mode

Pfeiffer Vacuum recommends standby mode for during process and production stops. With active stand-by mode, the electronic drive unit reduces the speed of the vacuum pump in the range of **30 to 100%** of the nominal speed. The factory setting is 66.7% of the nominal speed.

Setting the related parameters

1. Set the parameter [P:717] to the required value in %.
2. Set the parameter [P:026] to "0".
3. Set the parameter [P:002] to "1".
4. Check the set rotation speed (parameter [P:308] or [P:397]).

6.4.8 Normal operation

The vacuum pump starts in boost mode for max. 5 minutes with the maximum speed. The current is monitored at the same time. If the current is below a threshold value, the speed is controlled down to nominal rotation speed. In case the power input increases again, automatic increase of the speed does not take place. An increase in speed is reached again after vacuum pump stop / start.





Setting the related parameters

1. Set the parameter **[P:002]** to "0".
2. Set the parameter **[P:026]** to "0".
3. Check the set rotation speed (parameter **[P:308]**).

6.5 Operation monitoring

6.5.1 Operating mode display via LED

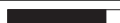
The LED on the electronic drive unit indicates the basic operating conditions. A differentiated malfunction and warning display is possible only for operation with DCU or HPU.

Display	Activity	Meaning
	None	<ul style="list-style-type: none"> • No adequate power supply
	10% active, 1 Hz	<ul style="list-style-type: none"> • No errors • Vacuum pump "OFF" • Vacuum pump stationary
	50 % active, 1 Hz	<ul style="list-style-type: none"> • No errors • Vacuum pump "OFF" • Vacuum pump still rotating
	90 % active, 1 Hz	<ul style="list-style-type: none"> • No errors • Vacuum pump "ON" • Set rotation speed not reached
	100% active	<ul style="list-style-type: none"> • No errors • Vacuum pump "ON" • Target speed reached
	50% active, 10, Hz	<ul style="list-style-type: none"> • Defect

Tbl. 13: Behavior and meaning of the LED of the electronic drive unit

6.5.2 Temperature monitoring

In event of impermissibly high pump temperature (> 75 °C), the motor speed is reduced to a nominal rotation speed ($n_N = 1800^{rpm}$) in order to avoid the vacuum pump from overheating.

After cooling down (< 72 °C), the vacuum pump starts to run at set rotation speed.

6.6 Pumping condensable vapors

Vapors or moisture from pumped media impair the throughput after condensation in the vacuum pump.

WARNING

Risk of explosion from reactive, explosive or other hazardous gas / air mixtures.

Uncontrolled inlet of gas at the flushing gas nozzle leads to sparks generated mechanically following diaphragm rupture, hot surfaces or to explosive gas / air mixtures in the vacuum system caused by static electricity.

- ▶ If necessary, use inert gas for supplying the flushing gas in order to avoid a potential ignition.

⚠ CAUTION

Risk of poisoning due to toxic process gases escaping

For intake pressures > 500 hPa, process gas may escape from the flushing gas nozzle.

- ▶ If necessary, use an extraction line.

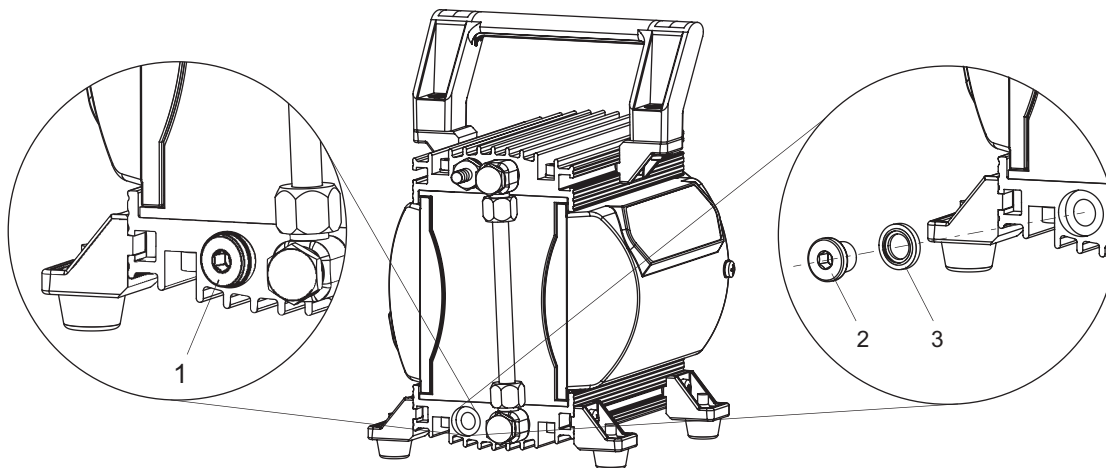

Fig. 7: Mounting the flushing gas nozzle

- | | |
|--------------------------------|--------|
| 1 Locking screw, G 1/8" | 3 Seal |
| 2 Flushing gas nozzle (0.3 mm) | |

Mounting the flushing gas nozzle

Using the optional flushing gas nozzle improves the discharge of condensate, and the pump achieves the specified final vacuum more quickly.

Required tools

- Allen key, WAF 5 mm

1. Screw in the flushing gas nozzle instead of the locking screw.
2. Bring the vacuum pump to operating temperature before starting the process.
3. Continue to operate the vacuum pump approx. 30 minutes after finishing the process before switching it off.

6.7 Switching off the vacuum pump

Procedure

You can switch off the vacuum pump in any pressure range.

1. Allow the vacuum pump to run on for a few more minutes with the intake port open.
2. Disconnect the voltage supply on the power supply pack.

7 Maintenance

7.1 Maintenance instructions

WARNING

Health hazard through poisoning from toxic contaminated components or devices

Toxic process media result in contamination of devices or parts of them. During maintenance work, there is a risk to health from contact with these poisonous substances. Illegal disposal of toxic substances causes environmental damage.

- ▶ Take suitable safety precautions and prevent health hazards or environmental pollution by toxic process media.
- ▶ Decontaminate affected parts before carrying out maintenance work.
- ▶ Wear protective equipment.

CAUTION

Danger of injury from moving parts

After a power failure or a standstill as a result of overheating, the motor restarts automatically. There is a risk of injury to fingers and hands if they enter the operating range of rotating parts.

- ▶ Safely disconnect motor from the mains.
- ▶ Secure the motor against reactivation.
- ▶ Dismantle the vacuum pump for inspection, away from the system if necessary.

NOTICE

Danger of property damage from improper maintenance

Unprofessional work on the vacuum pump will lead to damage for which Pfeiffer Vacuum accepts no liability.

- ▶ We recommend taking advantage of our service training offering.
- ▶ When ordering spare parts, specify the information on the nameplate.

The following section describes the tasks for cleaning and maintaining the vacuum pump.

Servicing the vacuum pump

1. Switch off the vacuum pump.
2. Allow the vacuum pump to cool if needed.
3. Vent the vacuum pump to atmospheric pressure via the intake side.
4. Disconnect the vacuum pump from the voltage supply.
5. Secure the motor against reactivation.
6. If you are carrying out maintenance work, disassemble the pump only to the extent necessary.
7. Do not use alcohol or other cleaning agents to clean the diaphragms and valves; use only a dry cloth.

7.2 Checklist for inspection and maintenance

Pfeiffer Vacuum recommends that all maintenance work is carried out by the manufacturer's service department. If the required intervals listed below are exceeded, or if maintenance work is carried out improperly, no warranty or liability claims are accepted on the part of Pfeiffer Vacuum. This also applies if original spare parts are not used.

Action	Inspection		Maintenance level 2	Required material
Interval	daily	as required; at least once every six months	as required; after 15000 hours at the latest	
Check silencer for contamination		■		
Clean the vacuum pump			■	Overhaul kit
Change the valves and diaphragms				
Change silencer			■	

Depending on the operating conditions, the required maintenance intervals can be shorter than the reference values specified in the table. Please consult Pfeiffer Vacuum if necessary.

Valves and diaphragms are wear parts. At the latest when the reached pressure values decrease, the suction chamber, the diaphragms as well as the valves should be cleaned and checked for cracks.

You can find the corresponding spare parts in the chapter Spare parts.

Tbl. 14: Maintenance intervals for diaphragm pumps

7.3 Replace the diaphragms and valves

NOTICE

Property damage from incorrect installation

Changed dead volume from incorrect installation of the original spacer disks worsens the final vacuum or leads to bearing damage.

- ▶ During disassembly, keep the existing spacer disks separate per installation location.
- ▶ Reinstall the original spacer disks back in-between the supporting washer and connection rod.

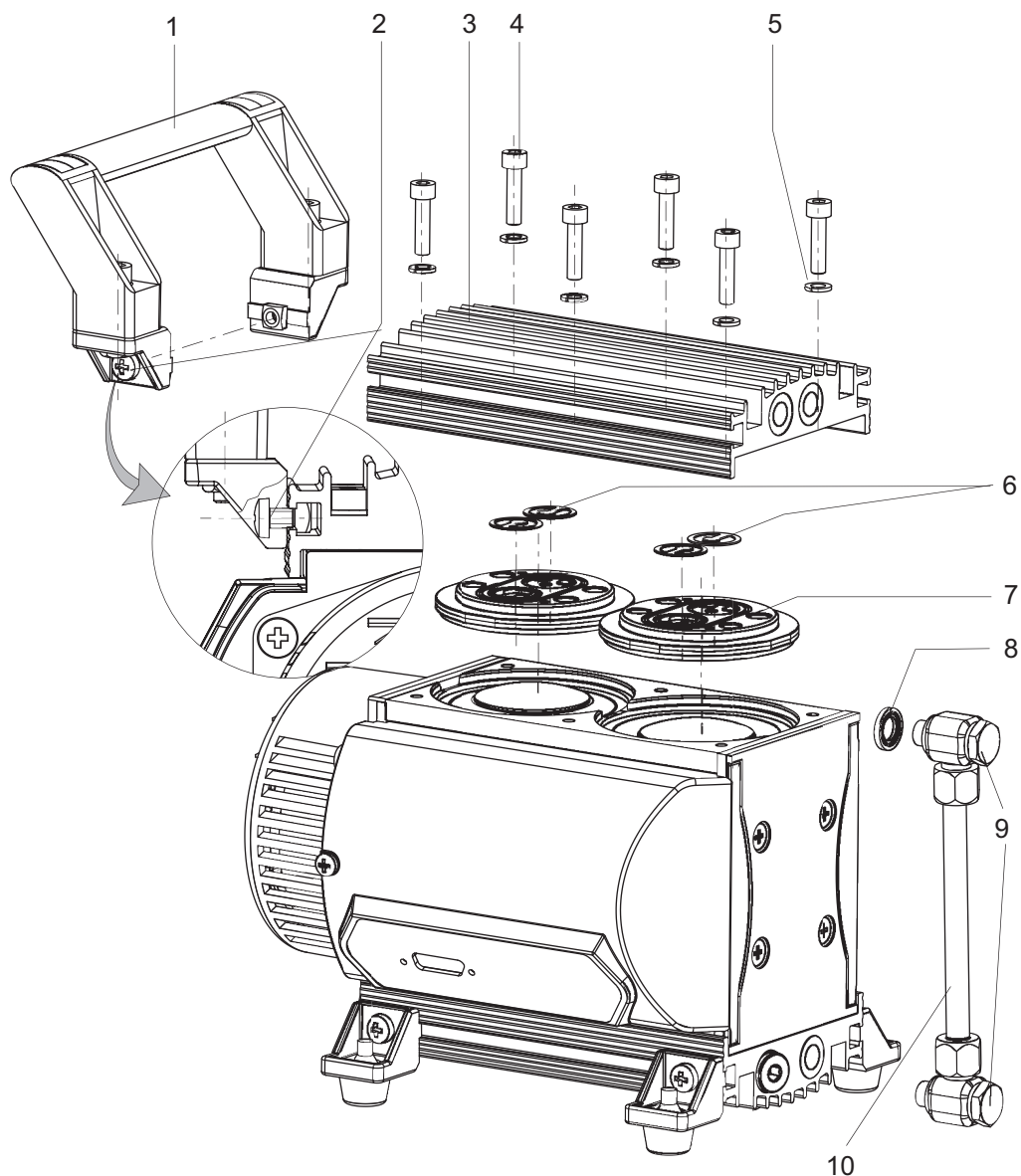

Fig. 8: Dismantle the pump head and replace the valves

1 Retainer	6 Valve (4×)
2 Crosshead screw (2×)	7 Head cover (2×)
3 Housing cover I	8 Sealing ring (2×)
4 Cheesehead screw (6×)	9 Banjo bolt (2×)
5 Lock washer (6×)	10 Hose connection



Avoid interchanging components

Always dismantle and mount only the pump head on one pump side in order to avoid interchanging the components.

Required tools

- Open-end wrench, 14 mm WAF
- Open-end wrench, 16 mm WAF
- Crosshead screw, size 2
- Allen key, 4 mm

Dismantle the pump head and valves

1. Switch off the vacuum pump.
2. Allow the vacuum pump to cool down.
3. Vent the vacuum pump to atmospheric pressure via the intake side.
4. Dismantle the hose connection by loosening the Banjo bolts.

5. Loosen the screws and push the handle from the groove in the housing cover I.
6. Unscrew the cylinder screws on the housing cover.
7. Remove the housing cover I.
8. Remove the head cover each with both valves.
 - If the valves stick to the housing cover I, carefully release the valves; otherwise, remove the valves from the head covers.

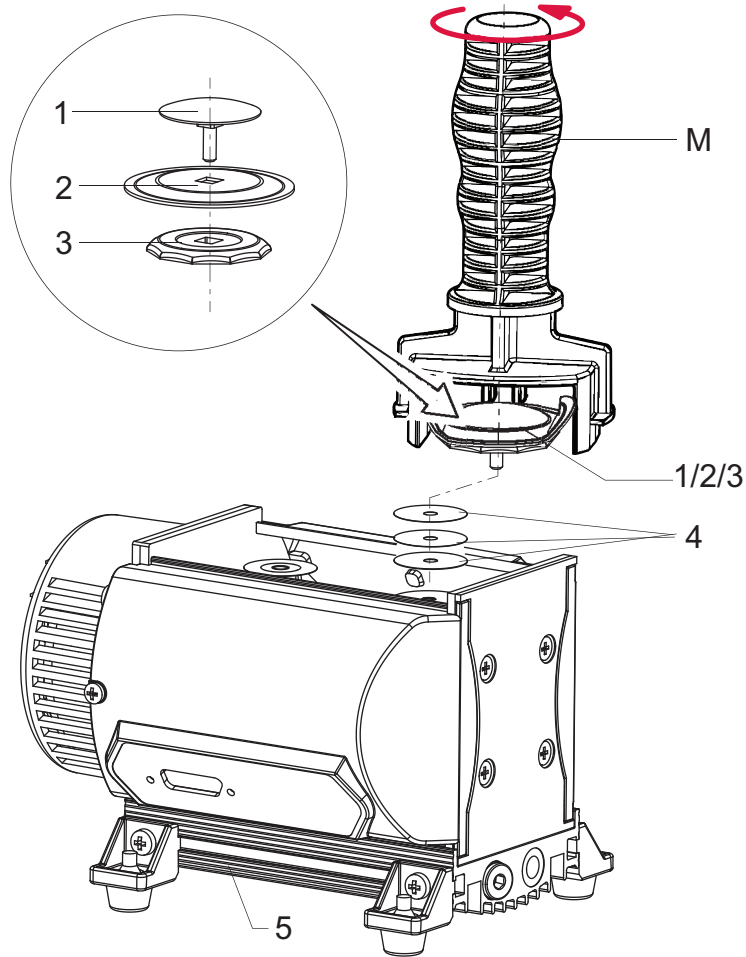

Fig. 9: Replacing the diaphragms

M	Diaphragm key	3	Supporting disk
1	Spring washer	4	Spacer disks
2	Diaphragm	5	Housing cover II

Prerequisites

- Housing cover and head cover have been dismantled.

Required tools

- Diaphragm key, 46 mm WAF

Dismantle the diaphragm

1. Carefully bend the diaphragm up to the side and in doing so, place the diaphragm key on the supporting disk;
 - do not use a sharp-edged tool.
2. If necessary, unscrew the supporting disk, diaphragm and spring washer.
3. Observe the spacer disk under the diaphragm;
 - reuse the original spacer disks per installation location when remounting.
4. Remove the supporting disk and the diaphragm from the square of the connecting screws of the spring washer.
 - If the diaphragm is stuck to the supporting disk, use alcohol or cleaning solvent to release it.

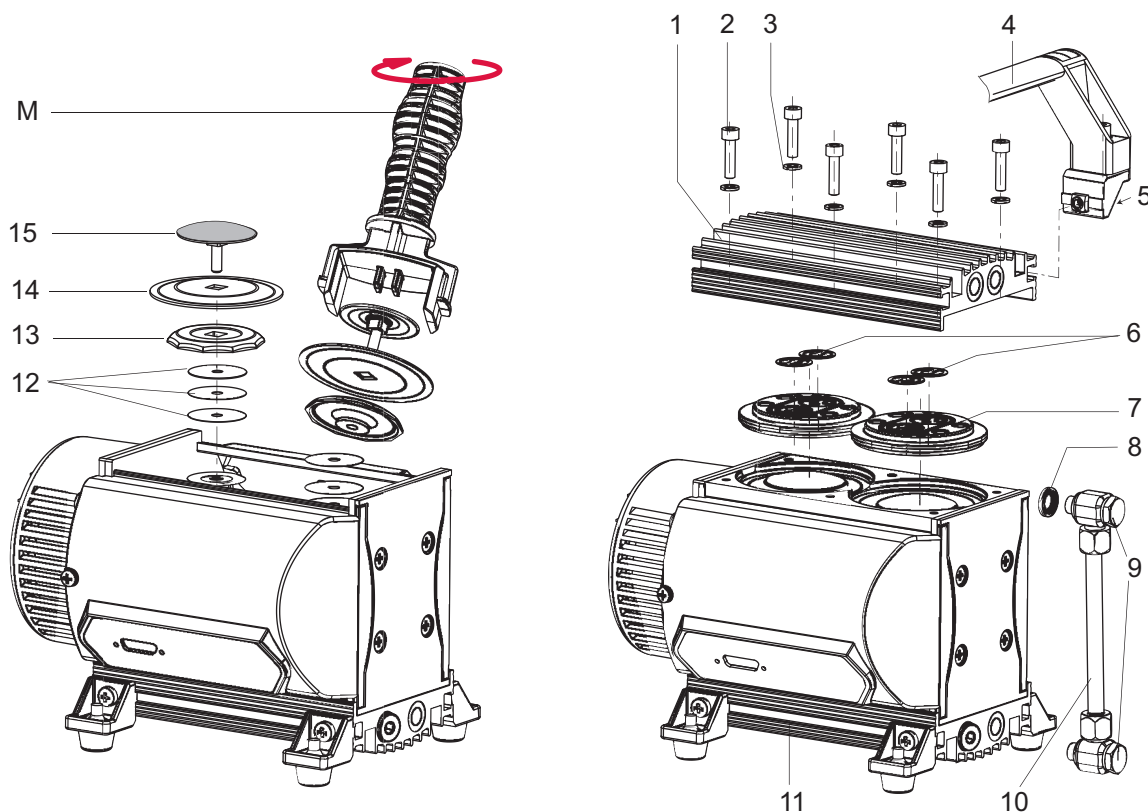

Fig. 10: Mounting the pump head

1 Housing cover	9 Banjo bolt (2×)
2 Cheesehead screw (6×)	10 Hose connection
3 Lock washer (6×)	11 Pump head 2
4 Retainer	12 Spacer disk (3×)
5 Crosshead screw (2×)	13 Supporting disk
6 Valve (4×)	14 Diaphragm
7 Head cover	15 Spring washer
8 Sealing ring (2×)	M Diaphragm key

Required tools

- Diaphragm key, 46 mm WAF
- Open-end wrench, 15 mm WAF
- Open-end wrench, 16 mm WAF
- Crosshead screw, size 2
- Allen key, 4 mm
- Calibrated torque wrench (tightening factor ≤ 1.6)

Mounting the pump head

1. Clean all parts.
2. Replace the wearing parts (valves and diaphragms) as per the spare parts pack.
3. Place the diaphragm (blue side upwards) and the supporting disk onto the square of the spring washer connecting screw; in doing so, observe the seat of the diaphragm in the square of the connecting screw.
4. Place the original spacer disks on the respective connection rod.
5. Use the diaphragm key and screw the supporting disk tight to the connection rod.
6. Mount the head cover and the valves; in doing so, observe the correct installation position of the valves.
7. Mount the housing cover.
8. Screw the cylinder screws on offset diagonally, hand tight first and then tight.
 - Tightening torque: **max. 6.0 ±1 Nm**
9. Mount the hose connection.
10. Push the handle into the intended grooves and screw the crosshead screws tight; in doing so, ensure the correct position of the handle above the center of gravity of the vacuum pump.

To change the valves and diaphragms on pump head 2, rotate the vacuum pump by 180° and proceed in the same manner.

7.4 Check the ultimate pressure

After working on the device (e.g. maintenance), check the **ultimate pressure of the vacuum pump**. Only where the vacuum pump reaches the specified ultimate pressure can the leakage rate, and thus the formation of potentially explosive mixtures in the pump interior, be avoided.



Observe the separate test specification for the vacuum pump!

Test values

- with gas ballast: < 3 hPa
- without gas ballast: < 2.5 hPa

Prerequisites

- The vacuum pump is mounted and correctly installed electrically.

Measure the ultimate pressure

Before the vacuum pump is reinserted, the final pressure should be checked and the final pressure values measured be compared with specifications in the Technical Data.

The vacuum pump reaches the specified ultimate pressure value after the diaphragm or valve are replaced, only after having been run in for several hours.

1. Connect a vacuum chamber (approx. 3 l) to a vacuum connection.
2. On the vacuum side, also connect a vacuum chamber and a pressure gauge (e.g. Pirani transmitter).
3. Operate the vacuum pump with flushing gas nozzle mounted for at least 2 hours.
4. In case of the unusual development of noise, switch the vacuum pump off immediately and check the position of the spring washers.
5. Measure the ultimate pressure and compare it with the test value.

If the vacuum pump does not reach the specified ultimate pressure

If, after replacing the diaphragm and valve, the values differ significantly from the specified values, and no changes result from the running in, proceed as follows:

1. Check the compression couplings of the connection hoses to the pump heads.
2. Check the valve seats and the suction chambers and repeat the ultimate pressure test.

8 Decommissioning

8.1 Decommissioning the vacuum pump for longer periods

Observe the following notes before shutting down the vacuum pump for a longer period of time:

Brief procedure after condensate forming

1. Allow the vacuum pump to run on for a few more minutes with the vacuum connection open.
2. In case media has entered the vacuum pump that may attack the pump materials or lead to deposits, clean the inside of the diaphragm heads.

Procedure for shutting down for longer periods

1. Disconnect the vacuum pump from the vacuum system.
2. Remove the vacuum pump from the vacuum system if necessary.
3. Close the vacuum and exhaust flanges with the original screw caps.
4. Store the vacuum pump only in dry, dust-free rooms, within the specified ambient conditions.
5. In rooms with humid or aggressive atmospheres: Hermetically seal the vacuum pump together with a drying agent in a plastic bag.

8.2 Disposing of the vacuum pump

WARNING

Health hazard through poisoning from toxic contaminated components or devices

Toxic process media result in contamination of devices or parts of them. During maintenance work, there is a risk to health from contact with these poisonous substances. Illegal disposal of toxic substances causes environmental damage.

- ▶ Take suitable safety precautions and prevent health hazards or environmental pollution by toxic process media.
- ▶ Decontaminate affected parts before carrying out maintenance work.
- ▶ Wear protective equipment.

Procedure

- ▶ Dispose safely of all substances according to local regulations.

9 Malfunctions

9.1 General

⚠ CAUTION

Danger of injury from moving parts

After a power failure or a standstill as a result of overheating, the motor restarts automatically. There is a risk of injury to fingers and hands if they enter the operating range of rotating parts.

- ▶ Safely disconnect motor from the mains.
- ▶ Secure the motor against reactivation.
- ▶ Dismantle the vacuum pump for inspection, away from the system if necessary.

⚠ CAUTION

Danger of burns on hot surfaces

In the event of a fault, the surface temperature of the vacuum pump can increase to above 105 °C.

- ▶ Allow the vacuum pump to cool down before carrying out any work.
- ▶ Wear personal protective equipment if necessary.

Vacuum pump and electronic drive unit malfunctions always result in a warning or error message. In both cases, you will receive an error code that you can read out via the interface of the electronic drive unit. If an error occurs, the vacuum pump switches off.

9.2 Error codes

Errors (** Error E—— **) always cause the vacuum pump to be switched off.

Warnings (* Warning F —— *) do not cause the vacuum pump to be switched off.

Handling malfunction messages

1. Read out the error codes via the display and control panel or the PC.
2. Remove the cause of the malfunction.
3. Reset the error message with parameter **[P:009]** or by pressing the button  on the DCU.

Error code	Problem	Possible causes	Remedy
Err098	Internal communication error between interface board and drive	–	<ul style="list-style-type: none"> • Contact Pfeiffer Vacuum Service.
Err117	Vacuum pump excess temperature (> 90 °C)	<ul style="list-style-type: none"> • Insufficient cooling 	<ul style="list-style-type: none"> • Improve the cooling • Check the operating conditions
Err174	Vacuum pump blocked	–	<ul style="list-style-type: none"> • Contact Pfeiffer Vacuum Service.

Tbl. 15: Error messages for the vacuum pump

Error code	Problem	Possible causes	Remedy
Wrn117	High temperature vacuum pump (> 75 °C)	<ul style="list-style-type: none"> • Insufficient cooling 	<ul style="list-style-type: none"> • Improve the cooling • Check the operating conditions

Tbl. 16: Warning messages for the vacuum pump

9.3 Warning and error messages when operating with DCU

Besides the device-specific warning and error messages on the electronic drive unit, additional messages are displayed with the connected display and control panel.

Display in DCU	Problem	Possible causes	Remedy
* Warning F110 *	Pressure gauge	<ul style="list-style-type: none"> • Pressure gauge faulty • Connection to the pressure gauge disconnected during operation 	<ul style="list-style-type: none"> • Check the cable connection • Carry out a restart with pressure gauge connected • Replace the pressure gauge completely
** Error E040 **	Hardware error	<ul style="list-style-type: none"> • external RAM faulty 	<ul style="list-style-type: none"> • Contact Pfeiffer Vacuum Service.
** Error E042 **	Hardware error	<ul style="list-style-type: none"> • EPROM checksum incorrect 	<ul style="list-style-type: none"> • Contact Pfeiffer Vacuum Service.
** Error E043 **	Hardware error	<ul style="list-style-type: none"> • E²PROM write error 	<ul style="list-style-type: none"> • Contact Pfeiffer Vacuum Service.
** Error E090 **	Internal device error	<ul style="list-style-type: none"> • RAM not large enough • DCU is connected to incorrect electronic drive unit 	<ul style="list-style-type: none"> • Contact Pfeiffer Vacuum Service. • Connect the DCU to the correct electronic drive unit
** Error E698 **	Communication error	<ul style="list-style-type: none"> • Electronic drive unit is not responding 	<ul style="list-style-type: none"> • Contact Pfeiffer Vacuum Service.

Tbl. 17: Warning and error messages when using a DCU

10 Service solutions from Pfeiffer Vacuum

We offer first class service

Long vacuum component service life, coupled with low downtimes, are clear expectations that you have of us. We satisfy your needs with capable products and outstanding service.

We are consistently striving to perfect our core competence, service for vacuum components. And our service is far from over once you've purchased a product from Pfeiffer Vacuum. It often enough really just begins then. In proven Pfeiffer Vacuum quality, of course.

Our professional sales engineers and service technicians stand ready to provide hands-on support to you worldwide. Pfeiffer Vacuum offers a complete portfolio of service offerings, ranging from genuine spare parts right through to service agreements.

Take advantage of Pfeiffer Vacuum Service

Whether for preventative on-site service from our field service, fast replacement with as-new replacement products or repair in a Service Center close to you; you have various options for upholding your equipment availability. Detailed information and addresses can be found on our website in the Pfeiffer Vacuum Service section.

Advice on the optimum solution is available from your Pfeiffer Vacuum contact partner. For quick and smooth handling of the service process, we recommend the following steps:



1. Download the current form templates.
 - Declaration of Service Request
 - Service Request
 - Declaration of Contamination

- a. Dismantle all accessories and keep them (all external mounted parts as valve, inlet screen, etc.).
- b. Drain the operating fluid/lubricant as necessary.
- c. Drain the cooling medium as necessary.



2. Fill out the service request and the declaration of contamination.



3. Send the forms via email, fax or post to your local Service Center.



4. You will receive a response from Pfeiffer Vacuum.

PFEIFFER VACUUM

Sending of contaminated products

No units will be accepted if they are contaminated with micro-biological, explosive or radioactive substances. If products are contaminated or if the declaration of contamination is missing, Pfeiffer Vacuum will contact the customer before starting maintenance. In addition, depending on the product and the level of contamination **additional decontamination costs** may be required.

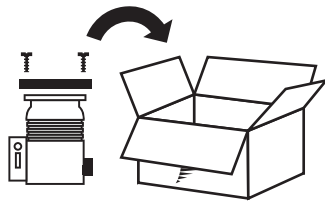

5. Prepare the product for transport in accordance with the details in the declaration of contamination.
 - a) Neutralize the product with nitrogen or dry air.
 - b) Close all openings with airtight blank flanges.
 - c) Seal the product in appropriate protective film.
 - d) Only pack the product in suitable, stable transport containers.
 - e) Observe the applicable transport conditions.

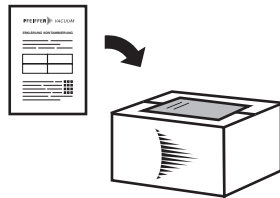

6. Affix the declaration of contamination to the **outside** of the packaging.

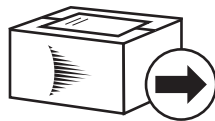

7. Then send your product to your local [Service Center](#).



8. You will receive a confirmation message/a quotation from Pfeiffer Vacuum.

PFEIFFER VACUUM

For all service orders, our [General Terms and Conditions of Sales and Supply](#) and [General Terms and Conditions of Repair and Maintenance](#) apply to vacuum equipment and components.

11 Spare parts packs

Ordering spare parts packs

1. Have the vacuum pump part number to hand, along with other details from the rating plate if necessary.
2. Only use original spare parts.
3. When ordering the overhaul kit, observe the respective part number of the diaphragm pump.

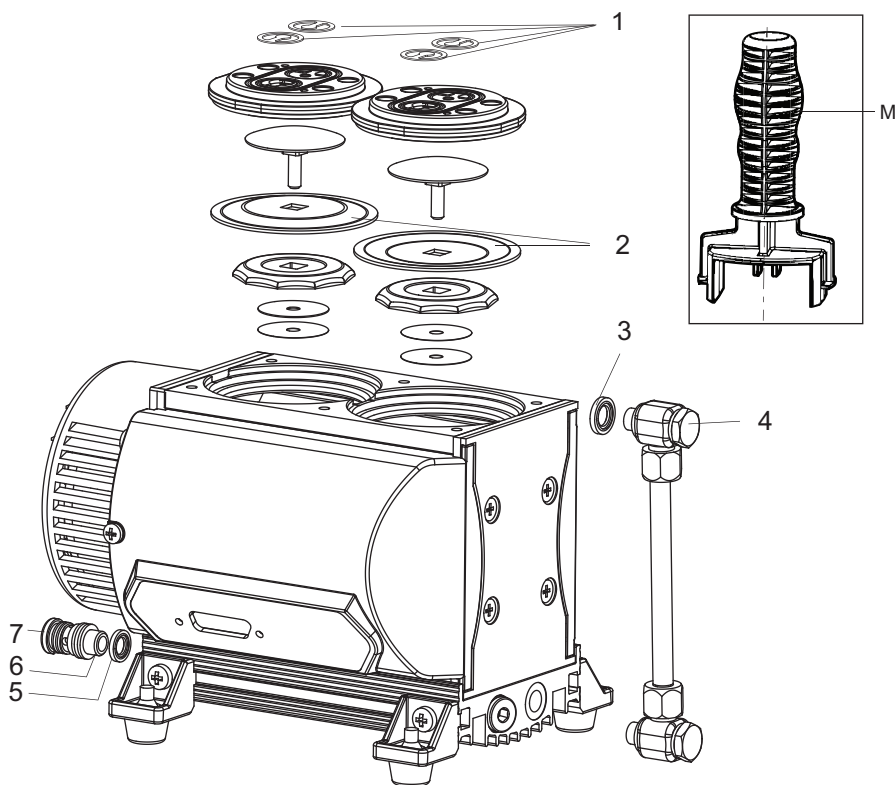

Fig. 11: Spare parts of the MVP 030-3 DC

- | | |
|----------------|--------------|
| 1 Valves | 5 Seal |
| 2 Diaphragm | 6 Silencer |
| 3 Sealing ring | 7 Hose piece |
| 4 Banjo bolt | |

Spare parts pack	Order no.	comprising the following parts
Overhaul kit incl. diaphragm key	PU E22 003 -T	Pos. 1 (8×) Pos. 2 (4×) Pos. 7 (1×) Pos. M
Sealing ring	P 3529 133 -P	Pos. 3
Banjo bolt	P 0995 943	Pos. 4
Silencer incl. hose piece	P 0995 942	Pos. 6, 7
Diaphragm key	P 0995 941	Pos. M

Tbl. 18: Spare parts of the MVP 030-3 DC

12 Accessories

Accessories for MVP 030-3 DC	order number
Hose Connection DN 6 x 400 mm with G 1/8" and G 1/4" Straight Fitting	P 0920 739 E
Hose Connection DN 6 x 1000 mm with G 1/8" and G 1/4" Straight Fitting	P 0920 817 E
Hose DN 6; (ø 8/6 mm)	P 0991 939
Push-In Fitting G 1/8" including Seal	P 4131 029 G
Mains Cable, 230 V AC, CEE 7/7 to C13	P 4564 309 ZA
Mains Cable, 115 V AC, NEMA 5-15 to C13	P 4564 309 ZE
Mains Cable, 115/230 V, without plug, socket (straight)	P 4564 309 ZH
Y-Connector M12	P 4723 010
Connection Cable MVP-TC-TPS	PE 100 013 -T
Screw-In Flange DN 16 ISO-KF / G 1/8" incl. Seal	PK 050 108 -T
Flushing Gas Nozzle for MVP 020-3 / MVP 030-3	PK 050 122
HPU 001, Handheld Programming Unit	PM 051 510 -T
RJ 45 Interface Cable on M12	PM 051 726 -T
Accessories Package for HPU	PM 061 005 -T
USB Converter to RS-485 Interface	PM 061 207 -T
Interface Cable, M12 m Straight/M12 m Straight	PM 061 283 -T
TPS 110, Power Supply Pack for Wall/Standard Rail Fitting	PM 061 340 -T
Wall Rail Fitting for TPS 110/180/310/400	PM 061 392 -T
Supply Cable DigiLine, M12, 4-pole to TPS, 1 m	PT 348 162 -T
Supply Cable DigiLine, M12, 4-pole to TPS, 3 m	PT 348 163 -T
Supply Cable DigiLine, M12, 4-pole to TPS, 6 m	PT 348 164 -T
Supply Cable DigiLine, M12, 4-pole to TPS, 10 m	PT 348 165 -T
DCU 002, Display Control Unit	PM 061 348 AT
Connection Cable with RS-485 Interface for TC 110/120 to power supply pack	PM 061 350 -T
Connection Cable for HiPace®	PM 061 543 -T
DCU 180, Display Control Unit	PM C01 821

Tbl. 19: MVP 030-3 DC accessories

13 Technical data and dimensions

13.1 General

Basis for the technical data of Pfeiffer Vacuum diaphragm pumps:

- Specifications according to PNEUROP committee PN5
- ISO 21360:2012: "Vacuum technology - Standard methods for measuring vacuum-pump performance - General description"

The following harmonized standards are fulfilled:

- IEC 61010-1
- UL 61010-1
- CSA 61010-1

	mbar	bar	Pa	hPa	kPa	Torr mm Hg
mbar	1	$1 \cdot 10^{-3}$	100	1	0.1	0.75
bar	1000	1	$1 \cdot 10^5$	1000	100	750
Pa	0.01	$1 \cdot 10^{-5}$	1	0.01	$1 \cdot 10^{-3}$	$7.5 \cdot 10^{-3}$
hPa	1	$1 \cdot 10^{-3}$	100	1	0.1	0.75
kPa	10	0.01	1000	10	1	7.5
Torr mm Hg	1.33	$1.33 \cdot 10^{-3}$	133.32	1.33	0.133	1

1 Pa = 1 N/m²

Tbl. 20: Conversion table: Pressure units

	mbar l/s	Pa m ³ /s	sccm	Torr l/s	atm cm ³ /s
mbar l/s	1	0.1	59.2	0.75	0.987
Pa m ³ /s	10	1	592	7.5	9.87
sccm	$1.69 \cdot 10^{-2}$	$1.69 \cdot 10^{-3}$	1	$1.27 \cdot 10^{-2}$	$1.67 \cdot 10^{-2}$
Torr l/s	1.33	0.133	78.9	1	1.32
atm cm ³ /s	1.01	0.101	59.8	0.76	1

Tbl. 21: Conversion table: Units for gas throughput

13.2 Technical data

Classification	MVP 030-3 DC
Order number	PK T01 500
Flange (in)	G 1/8"
Flange (out)	G 1/8" with silencer
Pumping speed	1.8 m ³ /h
Ultimate pressure without gas ballast	≤ 2 hPa
Ultimate pressure with gas ballast	≤ 3 hPa
Intake pressure max.	1100 hPa
Exhaust pressure, max.	1100 hPa
Integral leak rate	1 Pa m ³ /s
Operating voltage: DC	24 V
Input voltage: tolerance	±10 %

Classification	MVP 030-3 DC
Rated current absorption	1.5 A
Current max.	7,0 A
Rotation speed	600 – 2 400 rpm
I/O interfaces	RS-485
Cooling method, standard	Convection cooled
Operating altitude, max.	2000 m
Protection category	IP20
Ambient temperature	10 – 40 °C
Temperature: Storage	-10 – 60 °C
Sound pressure level	48 dB(A)
Weight	4.3 kg

Tbl. 22: Technical data, MVP 030-3 DC

13.3 Substances in contact with the media

MVP 030-3 DC	Substances in contact with the media
Housing cover	Aluminum alloy (AlMgSi)
Head cover	Aluminum alloy (AlMgSi)
Diaphragm clamping disk	Aluminum alloy (AlMgSi)
Diaphragm	PTFE
Valves	FPM
Inlet	Aluminum alloy (AlMgSi)
Outlet / silencer	Aluminum / silicon rubber
Threaded hose couplings	Anodized aluminum
Hose	PE

Tbl. 23: Materials that make contact with the process media inside the diaphragm pump

13.4 Dimensions

All dimensions in mm

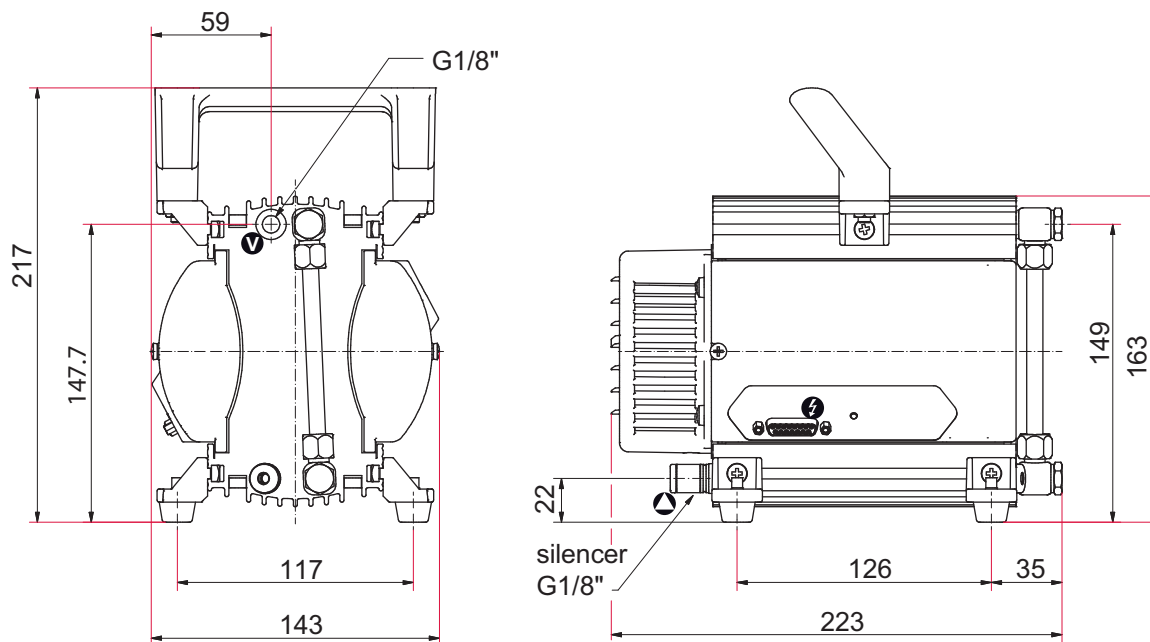

Fig. 12: Dimension diagram of the MVP 030-3 DC (SPI)

Declaration of conformity

We hereby declare that the product cited below satisfies all relevant provisions of the following EC Directives:

Machinery 2006/42/EC (Annex II, no. 1 A)

Electromagnetic compatibility 2014/30/EU

Restriction of the use of certain hazardous substances 2011/65/EU

The authorized representative for the compilation of technical documents is Mr. Sebastian Oberbeck, Pfeiffer Vacuum GmbH, Berliner Straße 43, 35614 Asslar, Germany.

MVP 030-3 DC

Harmonized standards and applied national standards and specifications:

EN ISO 12100: 2011

DIN EN 50581: 2013

EN 1012-2: 2011

EN 61010-1: 2011

EN 61326-1: 2013

EN 61010-1: 2010 (Ed. 3)

Signature:



Pfeiffer Vacuum GmbH
Berliner Straße 43
35614 Asslar
Germany

(Dr. Ulrich von Hülsen)
Managing Director

2018-03-16



VACUUM SOLUTIONS FROM A SINGLE SOURCE

Pfeiffer Vacuum stands for innovative and custom vacuum solutions worldwide, technological perfection, competent advice and reliable service.

COMPLETE RANGE OF PRODUCTS

From a single component to complex systems:

We are the only supplier of vacuum technology that provides a complete product portfolio.

COMPETENCE IN THEORY AND PRACTICE

Benefit from our know-how and our portfolio of training opportunities!

We support you with your plant layout and provide first-class on-site service worldwide.

ed. B - Date 1905 - P/N:PU0076BEN



Are you looking for a
perfect vacuum solution?
Please contact us

Pfeiffer Vacuum GmbH
Headquarters • Germany
T +49 6441 802-0
info@pfeiffer-vacuum.de

www.pfeiffer-vacuum.com

PFEIFFER  **VACUUM**