



SERVICE BULLETIN

Classification:

EC19-002

Reference:

NTB19-017

Date:

February 25, 2019

2016-2019 TITAN XD DIESEL; MIL ON WITH DTC P0299 FOR BOOST PRESSURE

APPLIED VEHICLES: 2016-2019 Titan XD Diesel (A61)

APPLIED ENGINE: Cummins 5.0 V8 Diesel

IF YOU CONFIRM

The MIL is ON with DTC **P0299** (BOOST PRESSURE) stored

And

- The engine air cleaner box and air filter:
 - Are free from debris
 - Are not damaged or have any restrictions
- The engine charge air cooler tube clamps are tight and tubes are free from leaks at the following locations:
 - The turbocharger compressor outlet
 - The charge air cooler inlet
 - The charge air cooler outlet
 - The intake manifold inlet
- The Boost Pressure Absolute is within +/- 1.5 PSI of ambient air pressure with ignition ON and engine OFF (observed in Data Monitor).

ACTION

Refer to Repair Overview on page 2.

IMPORTANT: The purpose of ACTION (above) is to give you a quick idea of the work you will be performing. You **MUST** closely follow the entire SERVICE PROCEDURE as it contains information that is essential to successfully completing this repair.

Nissan Bulletins are intended for use by qualified technicians, not 'do-it-yourselfers'. Qualified technicians are properly trained individuals who have the equipment, tools, safety instruction, and know-how to do a job properly and safely. NOTE: If you believe that a described condition may apply to a particular vehicle, DO NOT assume that it does. See your Nissan dealer to determine if this applies to your vehicle.

Repair Overview

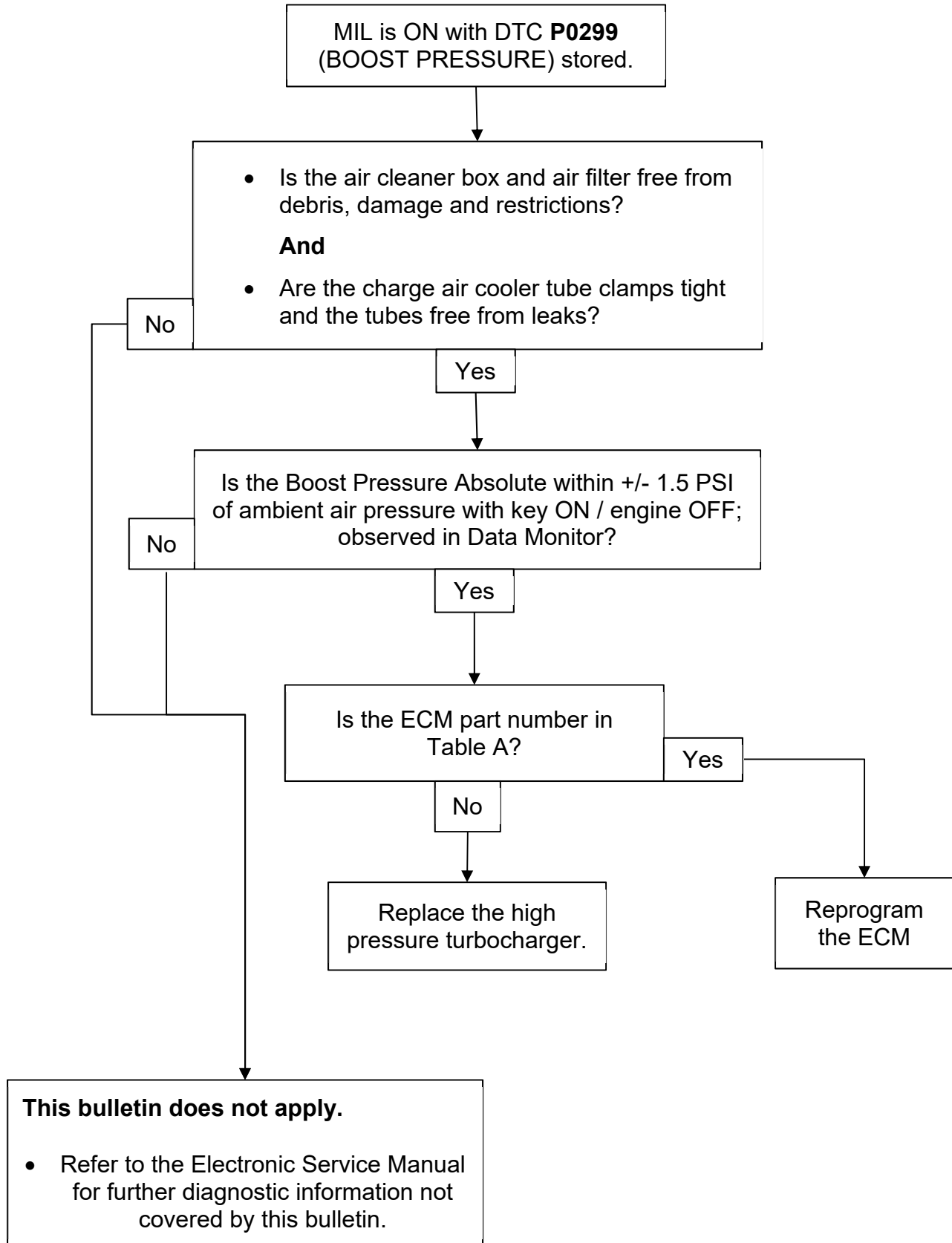

Required Special Tools

Special Tools – J-54423, J-54427, J-51951, and J-45695-A

J-54423: Air Handling System Clean Care Kit (see Figure 1)

J-54427: Fuel System Clean Care Kit (see Figure 2)

If needed – J-51951: Tech Cam (borescope – see Figure 3)

J-45695-A: Coolant Refill Tool (see page 4, Figure 4)

- These special tools have been previously sent to each dealer.
- Additional kits and components can be ordered from TECH•MATE at:
 - 1-800-662-2001
 - OR
 - nissantechmate.com

J-54423 & J-54427

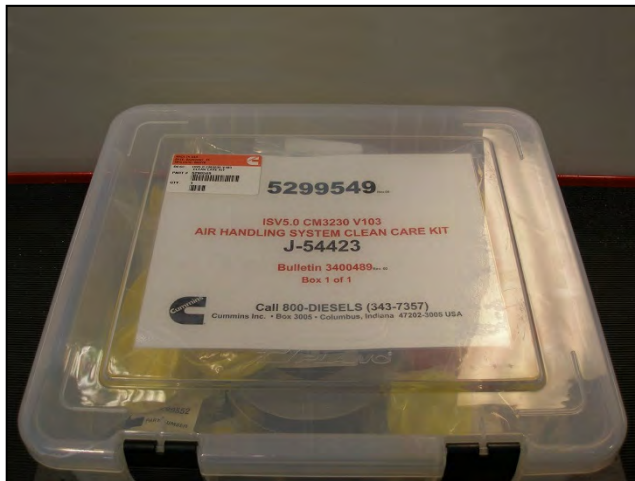

Figure 1



Figure 2

J-51951

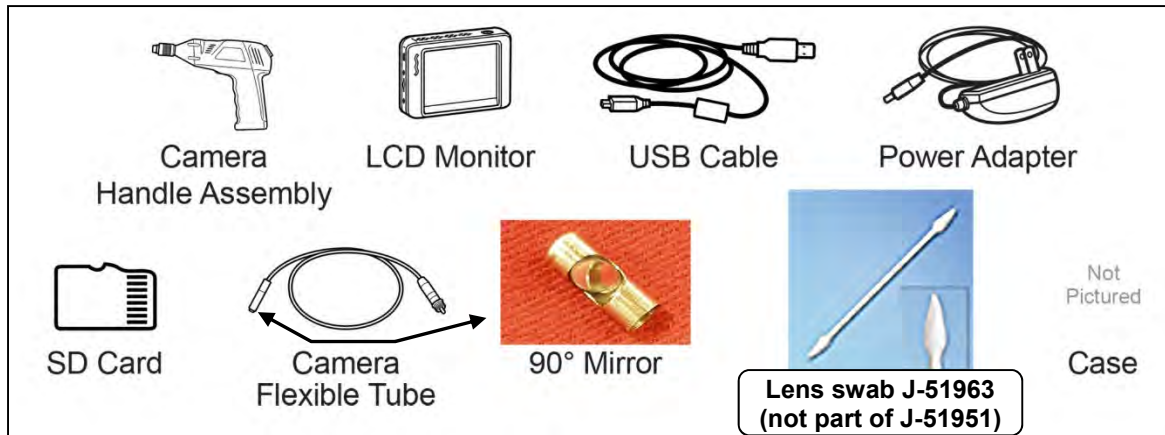

Figure 3

Required Special Tools (continued)

J-45695-A

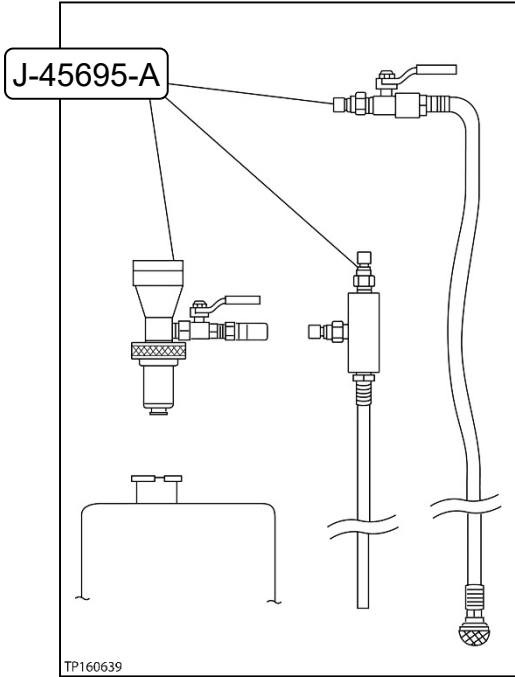

Figure 4

SERVICE PROCEDURE

Reprogram ECM

1. Using CONSULT-III plus (C-III plus), confirm the current ECM part number and write it on the repair order.
 - If it matches one of the part numbers in the **Current ECM Part Number** column in **Table A**, proceed to step 2.

NOTE: If a reprogram is available, do not replace the high pressure turbocharger.

 - If there is not a match, proceed to page 7; Replace High Pressure Turbocharger.

Table A

MODEL	CURRENT ECM PART NUMBER: 23710 -
2016-2019 Titan XD Diesel	EZ41C, EZ41D, EZ41E
	EZ42A, EZ42B, EZ42C

2. Navigate C-III plus to **ENGINE > Work Support**.
3. Select **SAVE COMPUTER DATA** and then select **Start**.

IMPORTANT: Before starting the reprogramming procedure, make sure:

- ASIST on the CONSULT PC has been synchronized (updated) to the current date.
- All CONSULT-III plus (C-III plus) software updates (if any) have been installed.
- The CONSULT PC is connected to the Internet (Wi-Fi or cable).

NOTE:

- If you are not familiar with the reprogramming procedure, [click here](#). This will link you to the "CONSULT- III plus (C-III plus) ECM Reprogramming" general procedure.
- For the Titan XD Diesel, the GR8 set to ECM power supply mode can be attached to either 12 volt battery.

CAUTION:

- Connect the GR8 to the 12V battery and select ECM Power Supply Mode. If the vehicle battery voltage drops below 12.0V or above 15.5V during reprogramming, the ECM may be damaged.
- Be sure to turn OFF all vehicle electrical loads. If a vehicle electrical load remains ON, the ECM may be damaged.
- Be sure to connect the AC Adapter. If the CONSULT PC battery voltage drops during reprogramming, the process will be interrupted and the ECM may be damaged.
- Turn OFF all external Bluetooth® devices (e.g., cell phones, printers, etc.) within range of the CONSULT PC and the plus VI. If Bluetooth® signal waves are within range of the CONSULT PC and the plus VI during reprogramming, reprogramming may be interrupted and the ECM may be damaged.

4. Reprogram the ECM.
5. After completing Erase ALL DTCs, print a copy of the C-III plus screen showing the before and after part numbers of the control unit and attach it to the repair order.
6. Navigate C-III plus to **ENGINE > Work support**.
7. Write the data saved in step 3.
 - Select **WRITE SAVED DATA** and then select **Start**.

END; Service Procedure complete.

Remove High Pressure Turbocharger

IMPORTANT: Follow all cautions, warnings, and notes in the **Electronic Service Manual (ESM)** when working on or near the fuel system, turbocharger system, and all parts and components related to the repair procedure in this bulletin.

CAUTION:

- Cover the surrounding areas of the engine bay with suitable protection to avoid damage to paint and all other surrounding exterior parts.
- When removing components such as hoses, tubes, fuel lines, etc., be sure to cap, plug, or tape these openings to prevent fluid from spilling or debris from entering.
 - Refer to special tools J-54423 and J-54427 for caps, plugs, and tape (see page 3).
 - The caps and plugs can be reused. Make sure to put them back in the kits when they are not needed.
 - When told to use tape, use the tape supplied in kit J-54423 only. When removed, this tape does not leave a residue. Tape residue may cause leaks.

1. Clean all loose dirt and debris from the engine bay area and wherever work is to be performed with a maximum of 30 psi compressed air.

WARNING: Wear appropriate eye protection and protective clothing. Failure to use protective eyewear and/or operating compressed air above 30 psi may increase the possibility of physical injury.

2. Record all audio presets.

Presets	1	2	3	4	5	6
AM						
FM 1						
FM 2						
SAT 1						
SAT 2/3						
Bass	Treble	Balance	Fade	Speed	Sen.	Vol.

3. Set the vehicle on a suitable lift, and then remove all tire and wheel assemblies.

NOTE: Removing the tire and wheel assemblies will allow the vehicle to be further lowered for easier access in the engine bay area.

4. Open the hood, and then place suitable covering protection over the fenders and all areas where leaning over and into the engine bay area.
5. Disconnect all battery cables, negative cables first.

6. Raise the vehicle, and then remove the front under cover (see Figure 5).

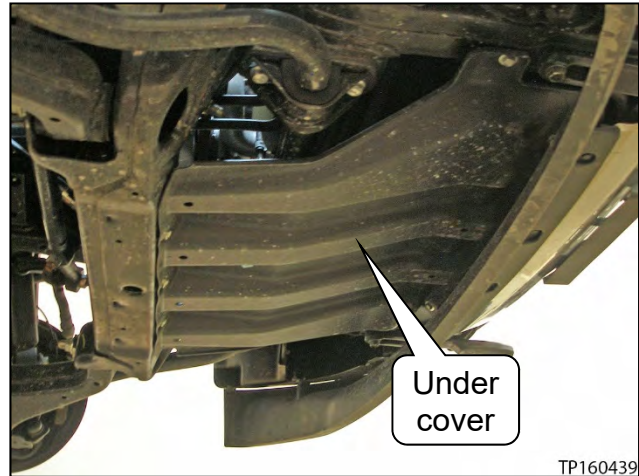

Figure 5

7. Drain the coolant from the radiator drain plug in a clean drain pan.

Tip: Reduce coolant spillage by first attaching a hose to the drain plug nipple.

- Remove the radiator cap and reservoir tank cap after opening the drain plug.
 - Reinstall both caps and tighten the drain plug once the coolant has finished draining.

NOTE: The coolant will be reused. Store the coolant in an area where it will not get contaminated.

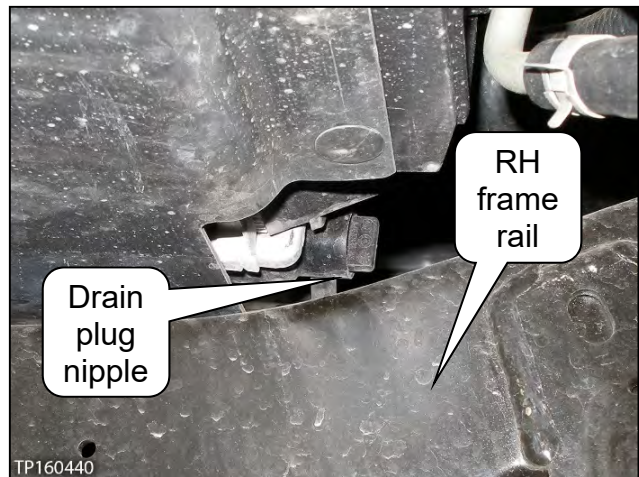

Figure 6

8. Disconnect the end of the reservoir tank coolant line shown in Figure 7.



Figure 7

9. Remove the cowl.
 - a. Make sure the wiper arms are in the auto stop, or “parked”, position.
 - b. Remove the wiper arm covers (see Figure 8).
 - c. Remove the wiper arm nuts, and then remove the wiper arms.
 - The wiper arms may need to be carefully rocked back and forth on their pivot shafts before coming loose.

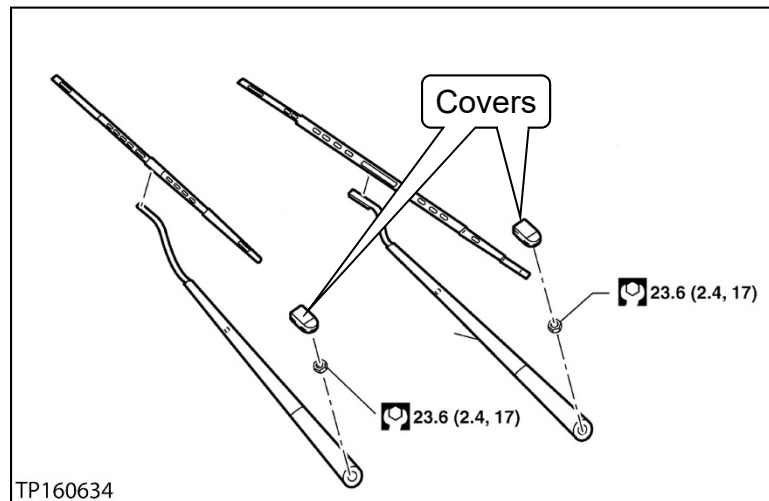

Figure 8

- d. Disconnect the washer nozzle supply hose (see Figure 9).

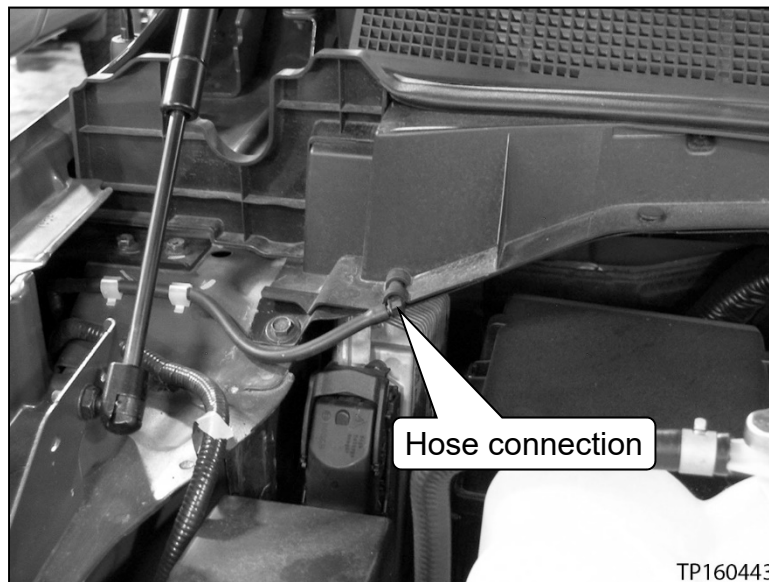

Figure 9

- e. Using a suitable tool, unsnap all pawls and clips, and then carefully remove the cowl top cover (see Figure 10, # 1).
- NOTE:** Remove the cowl top side trim cover(s) as needed (see Figure 10, # 2).
- f. Remove the cowl top extension bracket (see Figure 10, # 4).
 - g. Disconnect the electrical connector, remove the three (3) bolts, and then remove the wiper drive assembly (see Figure 11).
 - h. Remove the eight (8) bolts and both drain pipes, and then remove the cowl top extension (see Figure 10, # 3 & 5, and Figure 12 and Figure 13).

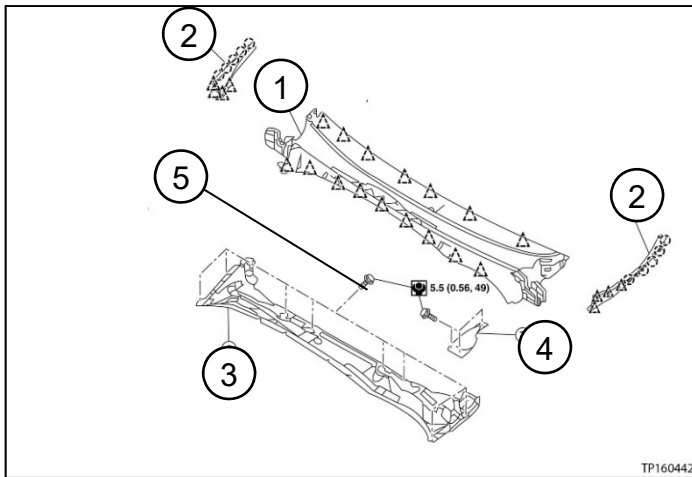

Figure 10

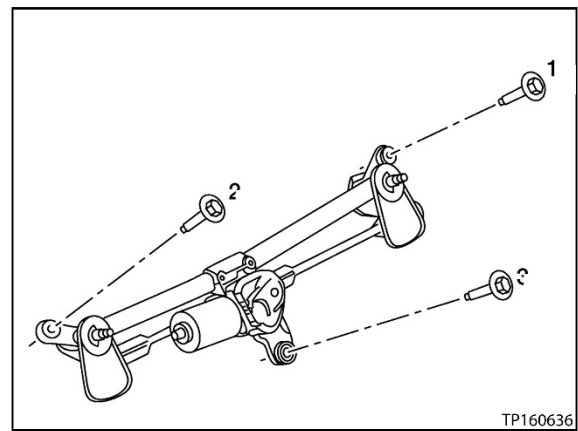

Figure 11

- 1. Cowl top cover
- 2. Cowl top side trim cover
- 3. Cowl top extension
- 4. Cowl top extension bracket
- 5. Cowl top extension bracket bolts

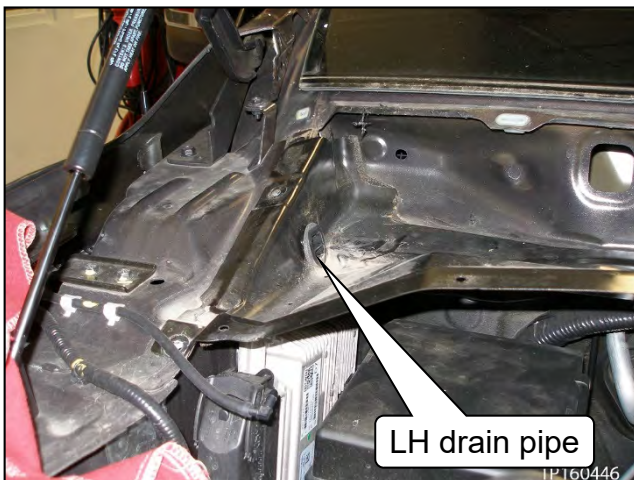

Figure 12

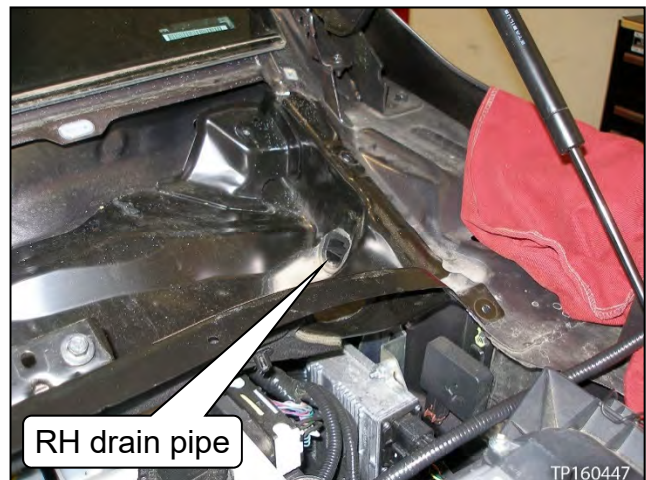

Figure 13

10. Remove the nine (9) bolts, and then remove all three heat shields (see Figure 14).

- The center heat shield needs to be removed first.
- The vehicle will need to be raised to access some of the bolts.

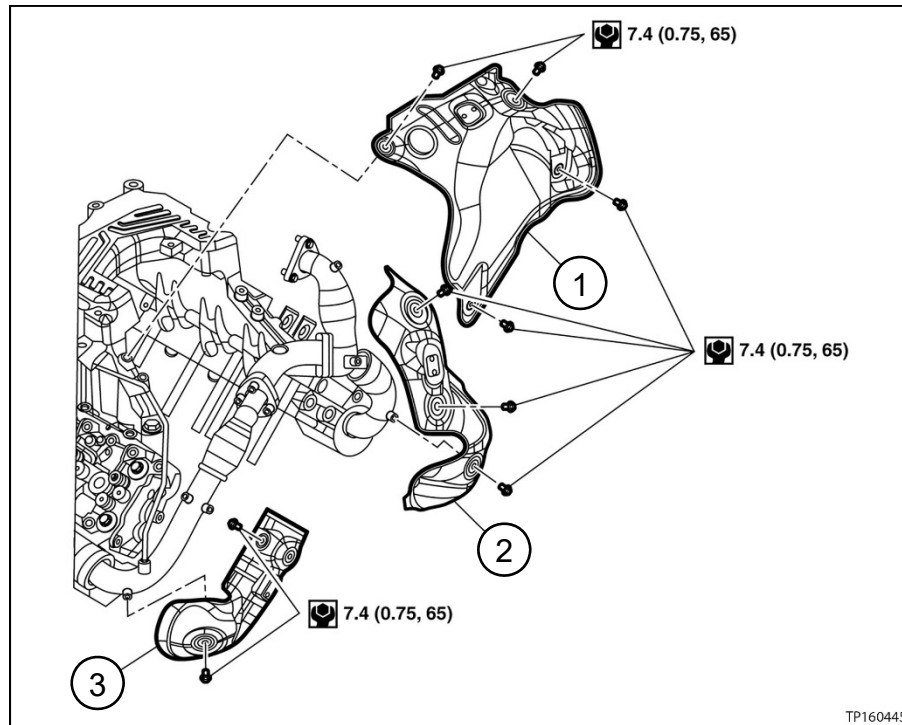

Figure 14

1. Center heat shield

2. RH heat shield

3. LH heat shield

11. Remove the air duct with upper air cleaner case (see Figure 15).

- The mass air flow sensor and turbocharger compressor intake pressure/temperature sensor will need to be disconnected.
- Make sure to cover the intake opening (see Figure 16).
- Place the air cleaner element where it will not be exposed to dirt or debris.

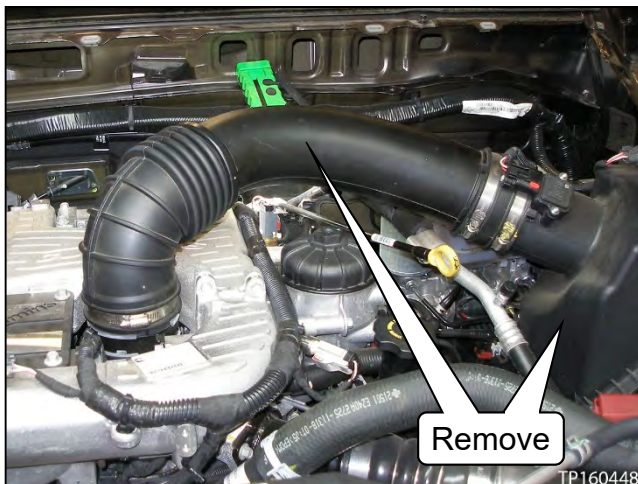

Figure 15



Figure 16

12. Disconnect the EGR valve actuator electrical connector (see Figure 17).

13. Disconnect the engine control harness connectors, and then move the section of engine control harness out of the way (see Figure 17).

- Figure 18 - Figure 20 shows how to unfasten the different types of connectors.

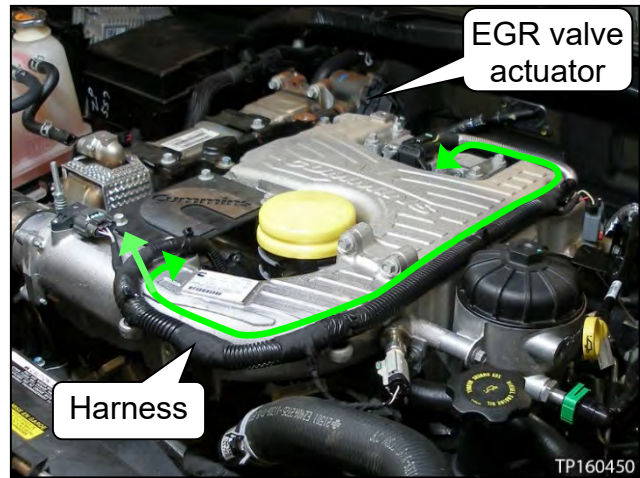

Figure 17

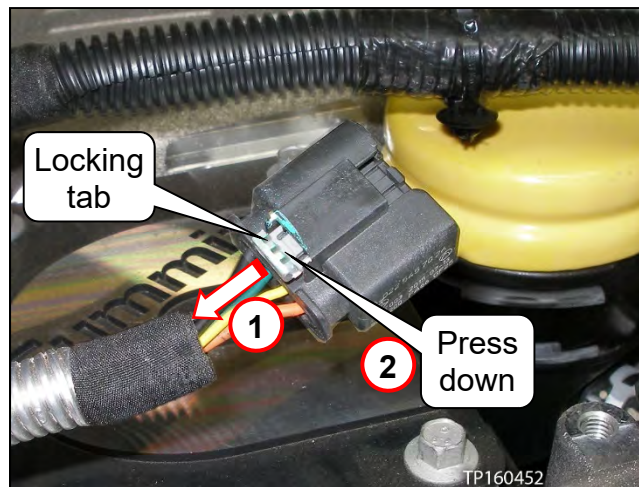

Figure 18

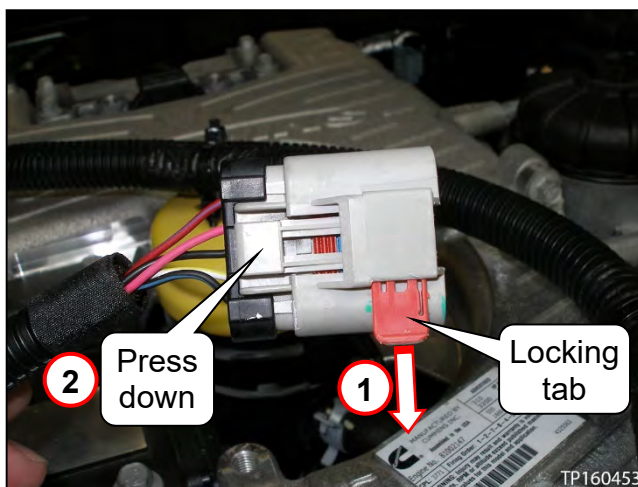

Figure 19

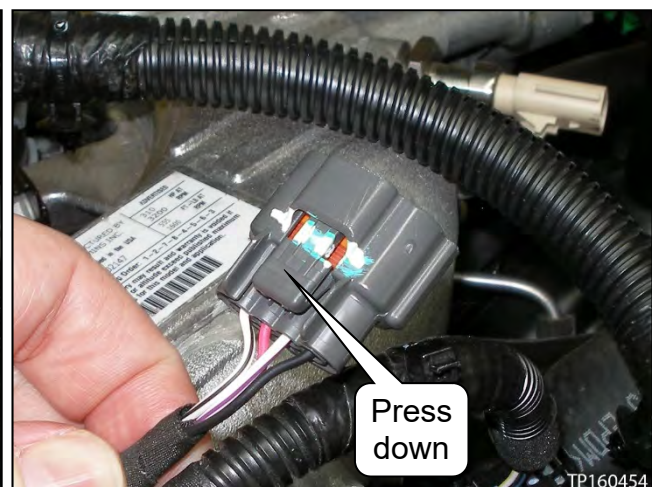

Figure 20

14. **IMPORTANT:** Check the engine oil level **NOW**, record the results.

- It is important to check the oil level at this time. See **CAUTION** on page 41, step 38.

15. Carefully remove the oil dipstick with tube.

a. Remove the bolt where shown in Figure 21.

- Figure 21 is viewed by looking down behind the rear of the turbocharger assemblies.

Tip: Use a magnet with extension to keep from losing the bolt.

b. Unclip the fuel lines from their clips (see Figure 22).

c. Remove the four (4) bolts where shown in Figure 22.

d. Carefully remove the oil dipstick and tube.

- Make sure the O-ring seal is attached to the oil dipstick tube.

NOTE: The fuel line bracket stays bolted to the oil dipstick tube.

CAUTION:

- Do not put side pressure on the fuel injector drain line (drain line). See page 15, Figure 27. If side pressure is applied, the drain line may be damaged.
- Be careful not to bend or kink the oil dipstick tube while removing.

e. Install a plug into the oil dipstick tube's engine block hole (see Figure 23).

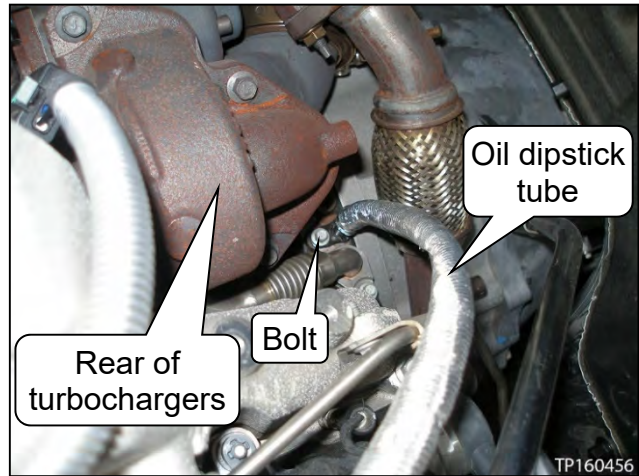

Figure 21

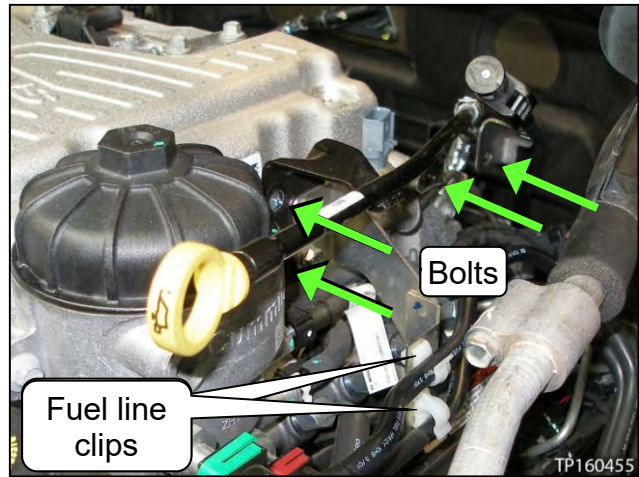

Figure 22

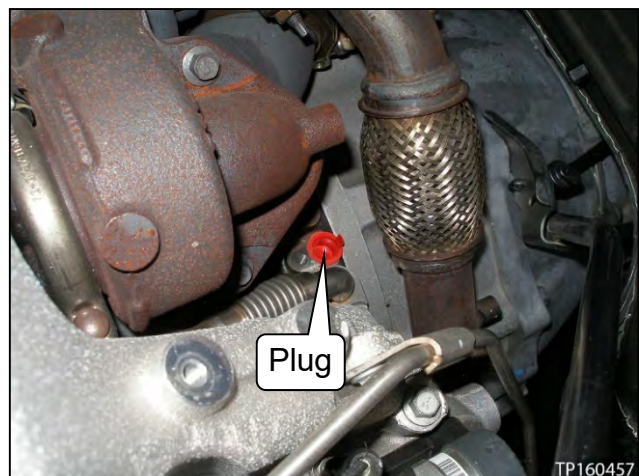

Figure 23

16. Unfasten the stage 2 fuel filter assembly from the intake manifold assembly.

a. Drain fuel from the primary fuel lines, stage 2 fuel filter assembly, and stage 1 fuel filter assembly.

- Open the drain valve and allow fuel to drain in a suitable container until the fuel slows down to a trickle (see Figure 24).
- Dispose of the drained fuel following local regulations.

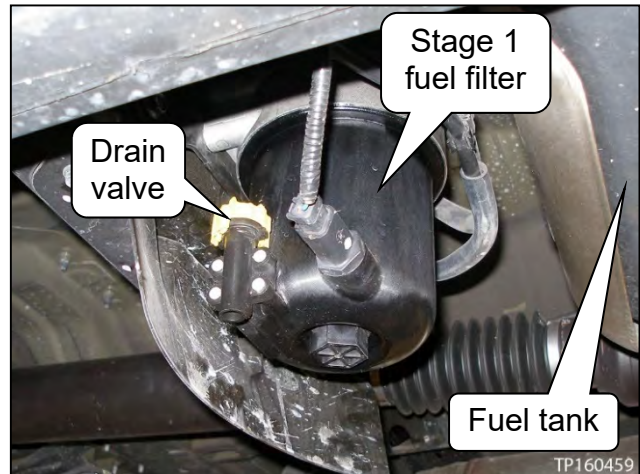

Figure 24

b. Place clean shop cloths under the stage 2 fuel filter assembly fuel line (see Figure 25).

NOTE: Although the fuel lines and fuel filter assemblies have been drained, some residual fuel may still drain out.

c. Disconnect the fuel line shown in Figure 25 and Figure 26.

- To remove the fuel line, pinch the tabs on both sides of the fuel line connector, and then pull off (see Figure 26).

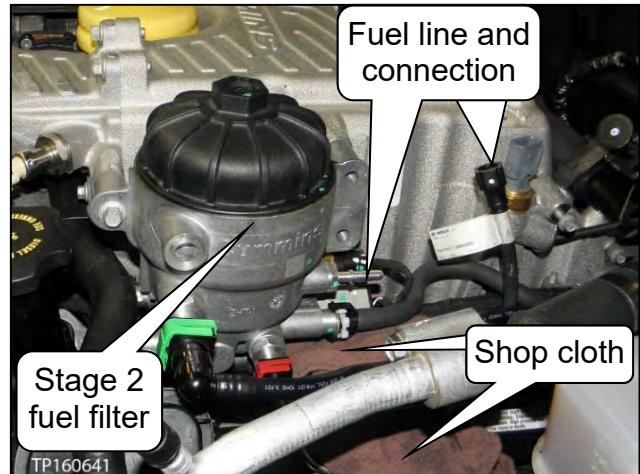

Figure 25

CAUTION: Make sure nothing (dirt, debris, etc.) gets inside the fuel system. Particles as small as 3 microns may damage the fuel system components.

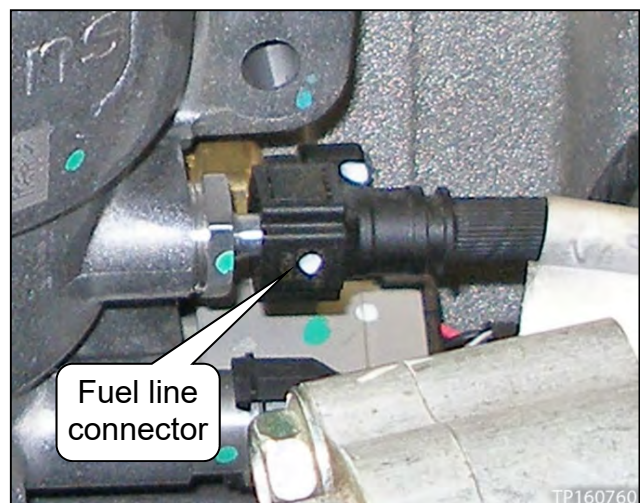

Figure 26

- d. Carefully move and secure the fuel line out of the way with a tie strap (see Figure 27).
- Put a plug in the fuel line.
 - Cap the fuel line's connection on the stage 2 fuel filter assembly (no picture shown).

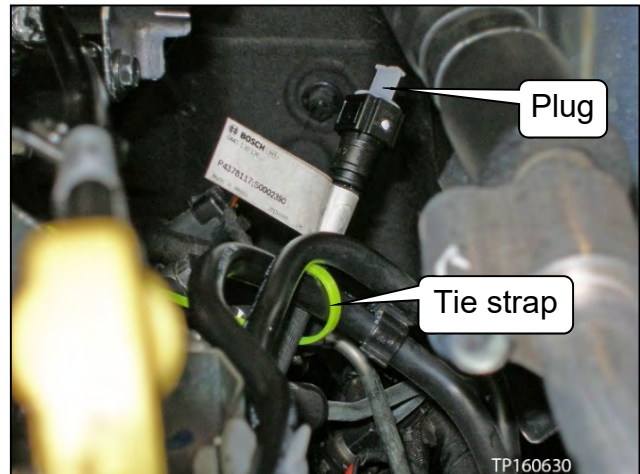

Figure 27

- e. Remove the last stage 2 fuel filter assembly bolt (see Figure 28).
- The stage 2 fuel filter assembly will sit close to its normally bolted-on position.
- CAUTION:** Do not lean on the stage 2 fuel filter assembly at any time while it is unbolted.

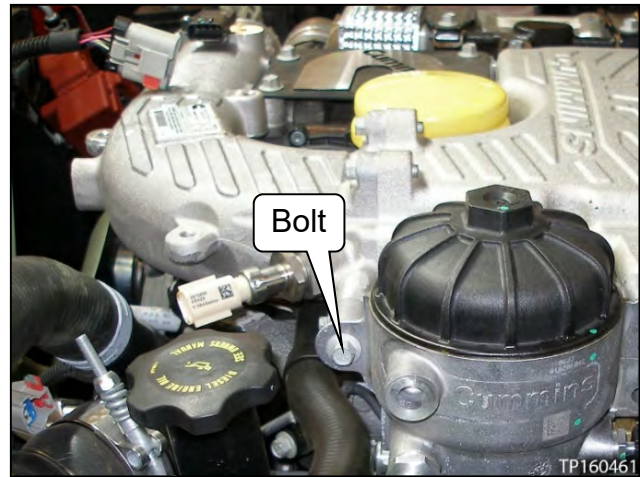

Figure 28

17. Remove the bolt, and then unclamp and disconnect the breather tube from the valve cover (see Figure 29).
- The breather tube will be removed with the air inlet connection assembly later on.

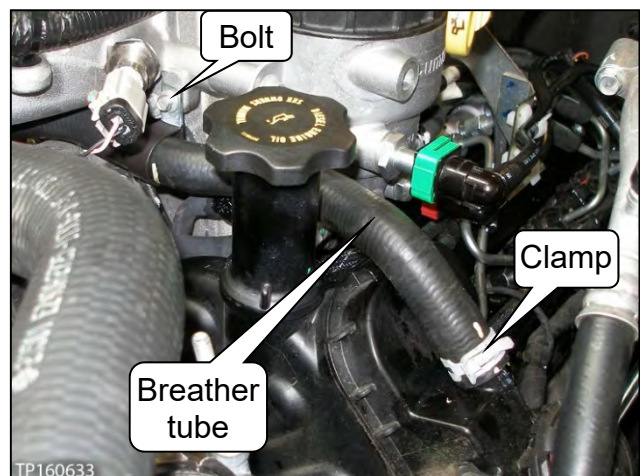

Figure 29

18. Remove the three (3) EGR valve inlet pipe bolts (see Figure 30).

- The third bolt cannot be seen in Figure 30.

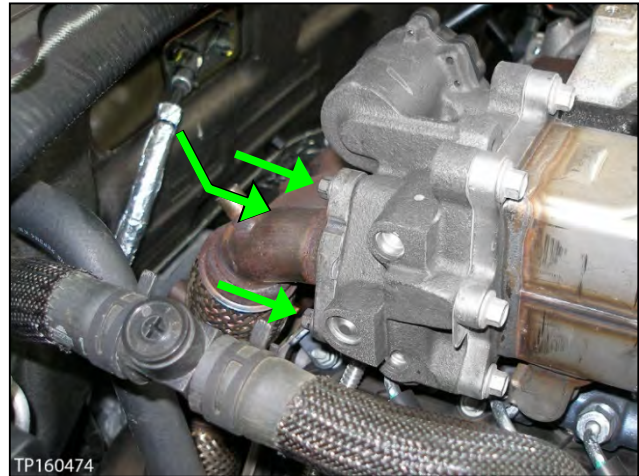

Figure 30

19. Remove the exhaust pressure sensor tube (see Figure 31 and Figure 32).

- Unfasten the flare nut.
 - The flare nut can be accessed from the engine bay area or from under the vehicle.
- Remove Bolt 1.
- Remove Bolt 2.

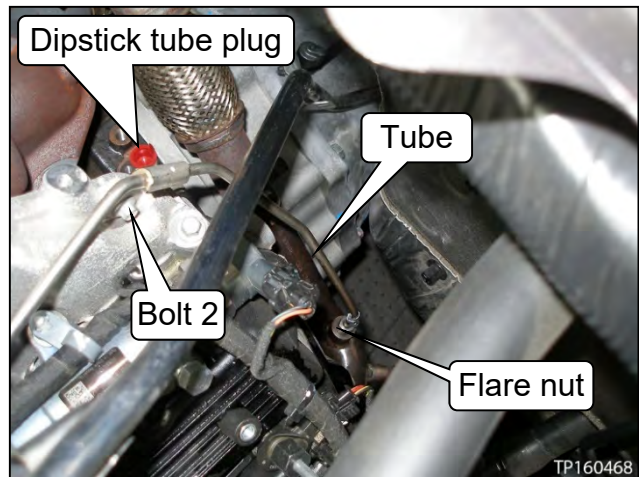

Figure 31

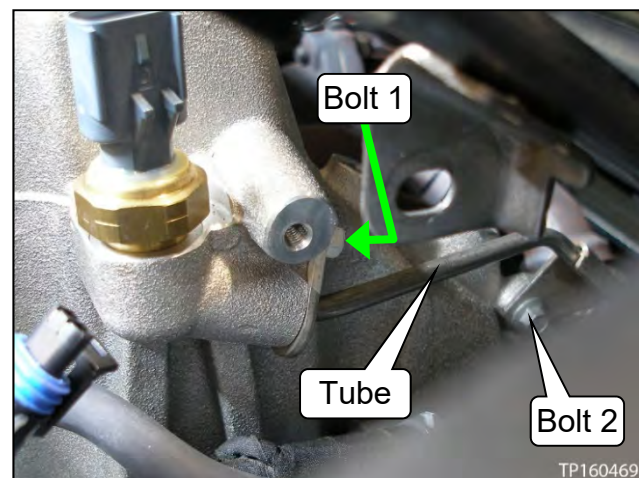

Figure 32

20. Remove the three (3) EGR bypass tube bolts (see Figure 33).

- The third bolt cannot be seen in Figure 33.

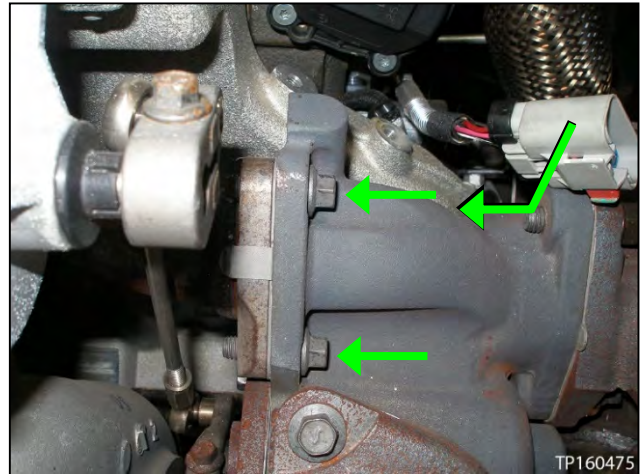

Figure 33

21. Loosen the bolt, and then dismount the **UPPER** rotary turbine control valve linkage (see Figure 34).

CAUTION: Do not unbolt the LOWER rotary turbine control valve linkage. If unbolted, the rotary turbine control valve linkage must be replaced.

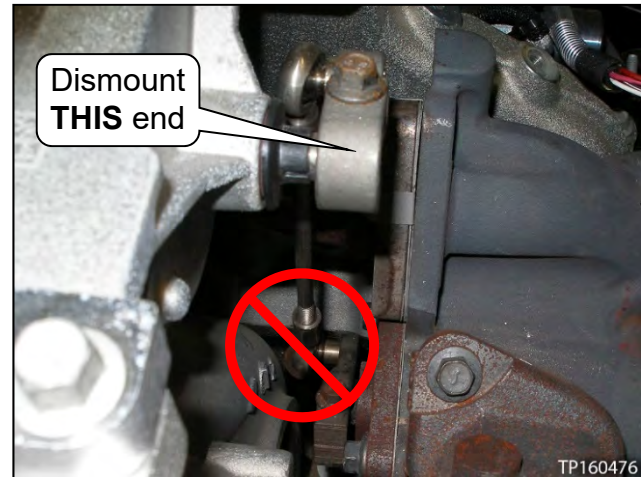

Figure 34

22. Remove both water transfer connection bolts (see Figure 35).

23. Remove the EGR bypass valve coolant tube bolt (see Figure 35).

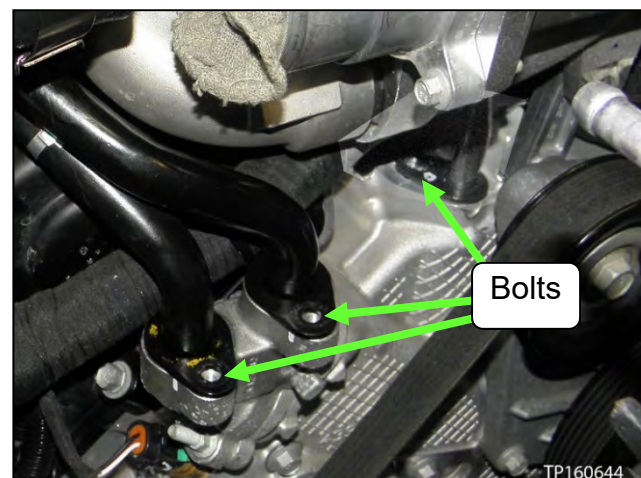

Figure 35

24. Remove the air intake connection bolt (see Figure 36).

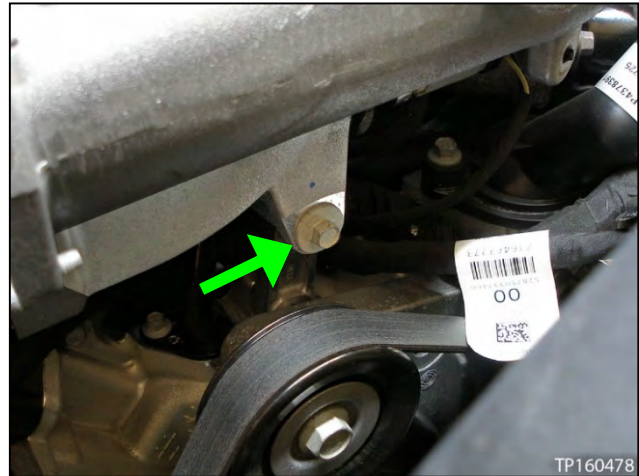

Figure 36

25. Remove the air inlet connection assembly bolt (see Figure 37).



Figure 37

26. Loosen the air outlet hose clamp nut, and then separate from the intake manifold inlet (see Figure 38).

- Make sure to cover both openings with tape.



Figure 38

27. Disconnect the EGR temperature sensor connector (see Figure 39 and Figure 40).

- This sensor is located under the front of the intake manifold.

NOTE: The EGR temperature sensor may need to be disconnected during removal of the intake manifold. Its locking tab may not be accessible otherwise.

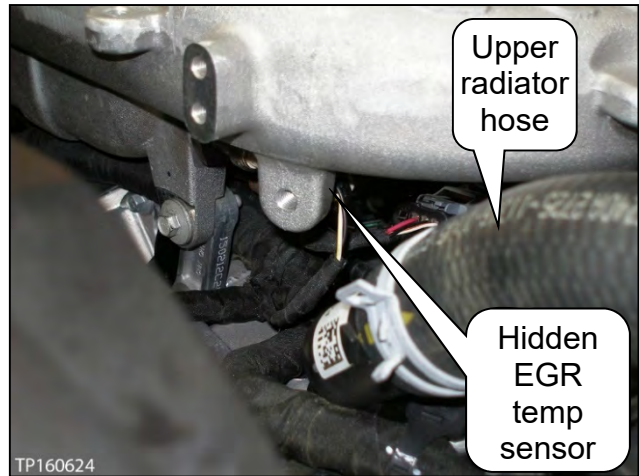

Figure 39

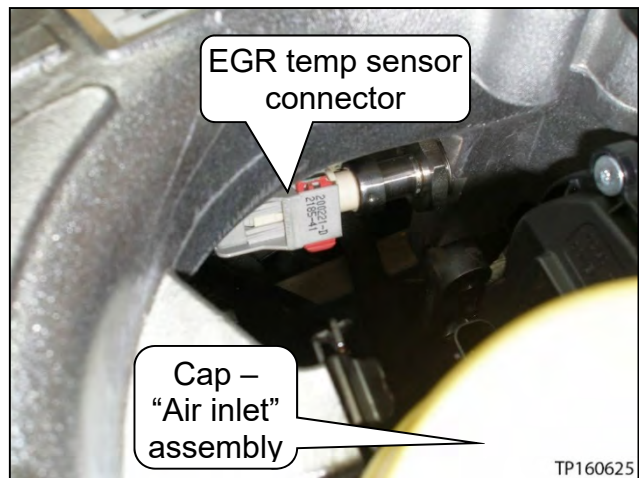

Figure 40

28. Remove the eight (8) intake manifold bolts, and then carefully remove the intake manifold assembly.

- See bolt locations in Figure 41 and Figure 42.
- If not done yet, disconnect the EGR temperature sensor connector during intake manifold removal (see page 19, step 27).

CAUTION: Due to its weight and location, use proper lifting equipment or assistance when lifting and removing the intake manifold assembly.

NOTE: The EGR bypass valve coolant tube may come out with the intake manifold assembly. This is okay.

- See page 17, step 23 for tube identification.

NOTE: Three of the intake manifold bolts on the “EGR valve” side cannot be seen in Figure 42.

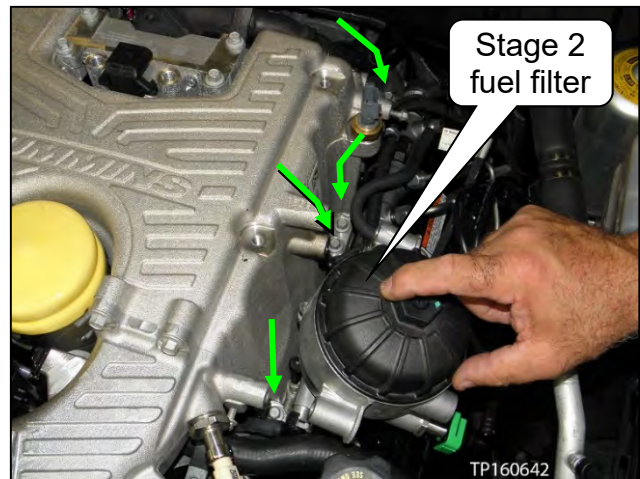

Figure 41

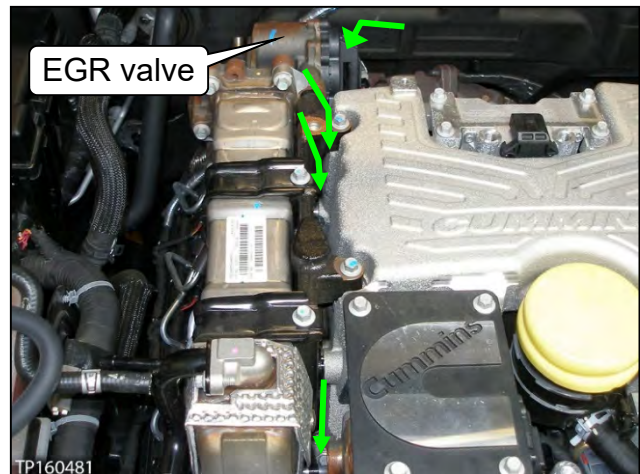

Figure 42

29. Remove any remaining intake manifold gaskets, and then install the plugs and caps (yellow and red colored) where shown in Figure 43.

CAUTION: Failure to cover all engine, coolant, and fuel system openings may allow dirt/debris to enter, causing engine and/or fuel system damage.

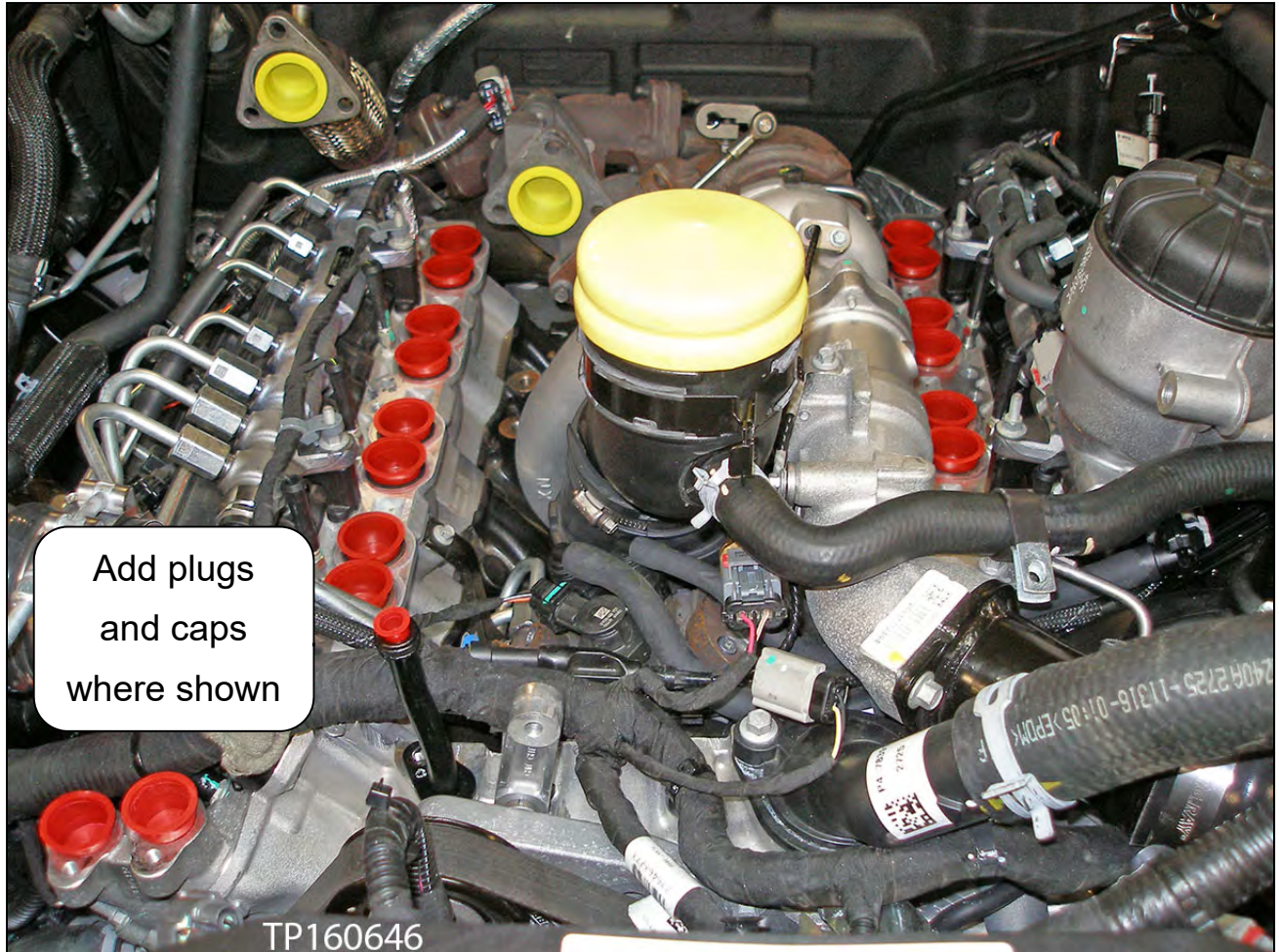

Figure 43

30. Unbolt the high pressure turbocharger from the low pressure turbocharger (see Figure 44).

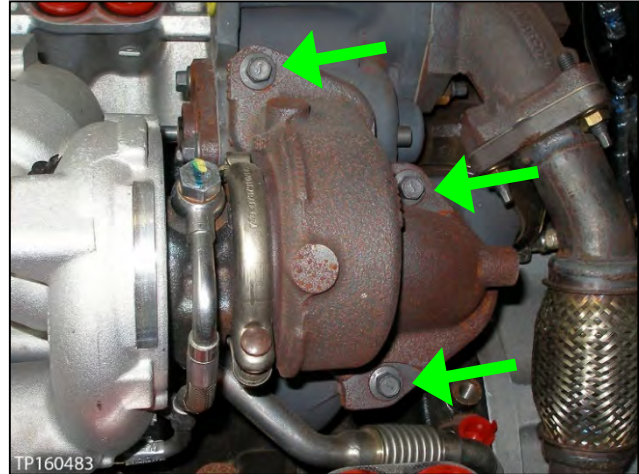

Figure 44

31. Disconnect the vacuum hose (see Figure 45).

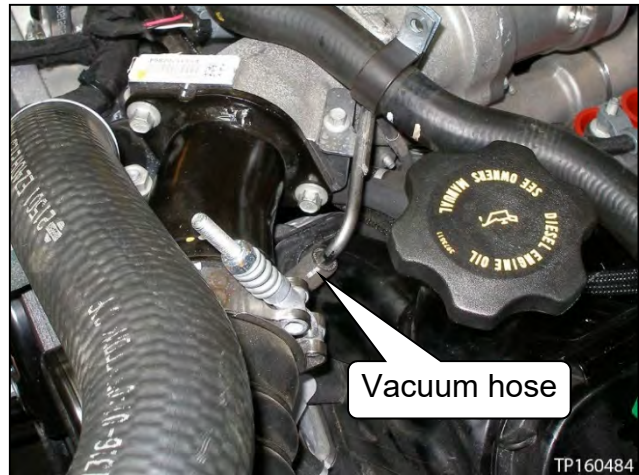

Figure 45

32. Loosen the charge-air cooler outlet tube clamp, and then separate it from the turbocharger compressor outlet (see Figure 46).

- Make sure to cover both openings with tape.



Figure 46

33. Disconnect the connectors for the low pressure turbocharger boost pressure sensor and high pressure turbocharger speed sensor (see Figure 47).

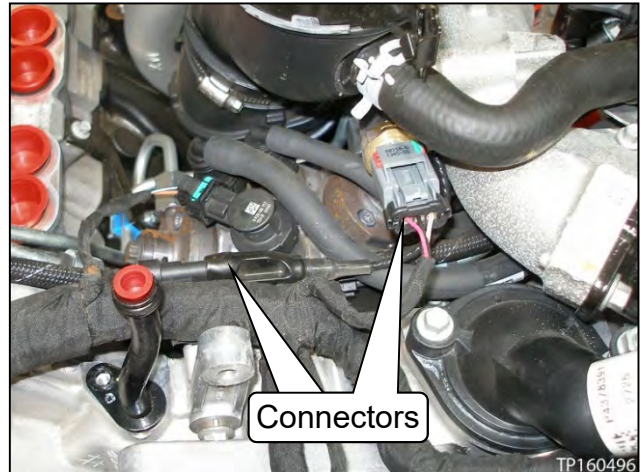

Figure 47

34. Loosen the clamp, and then remove the air inlet connection assembly (see Figure 48).

- Leave the cap on.

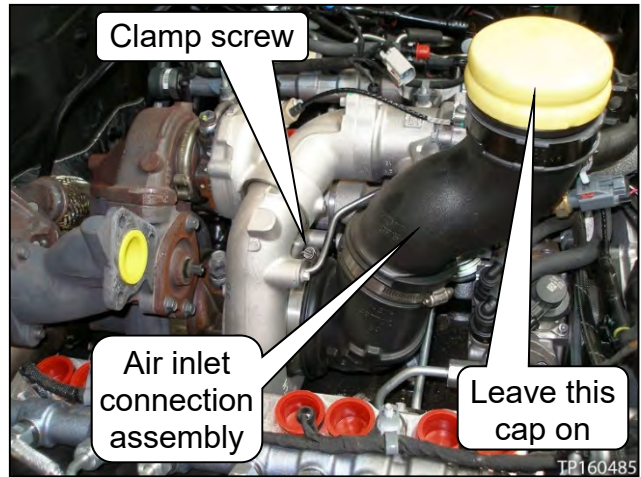

Figure 48

35. Cover the low pressure turbocharger inlet (see Figure 49).



Figure 49

36. Remove the banjo bolts for the high pressure and low pressure turbochargers (see Figure 50 and Figure 51).

- Also remove the banjo bolts' copper gaskets.
 - These gaskets will not be reused.
- Cover the low pressure turbocharger oil hole with tape.

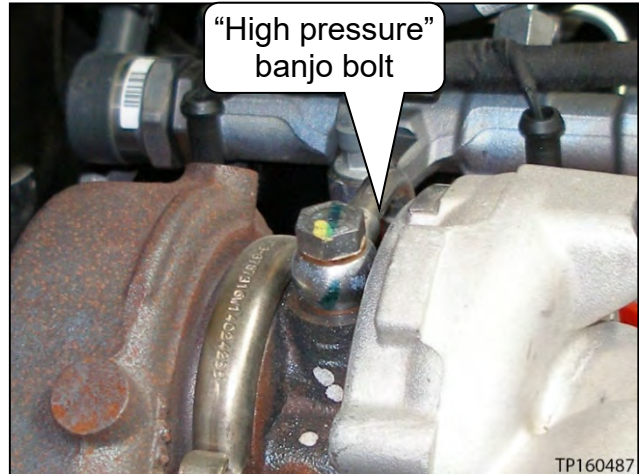

Figure 50

IMPORTANT: Both banjo bolts must be removed in order to remove the HP turbocharger assembly.

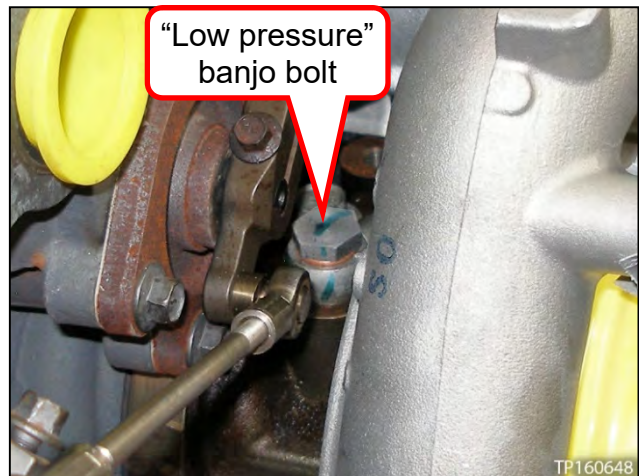

Figure 51

37. Remove the three (3) bolts, and then remove the low pressure turbocharger boost pressure sensor tube (see Figure 52).

- Cover the hole with tape (see Figure 53).

38. Unbolt, unclamp, and then remove the high pressure turbocharger speed sensor (see Figure 52).

- Cover the hole with tape (see Figure 53).

High pressure turbocharger speed sensor

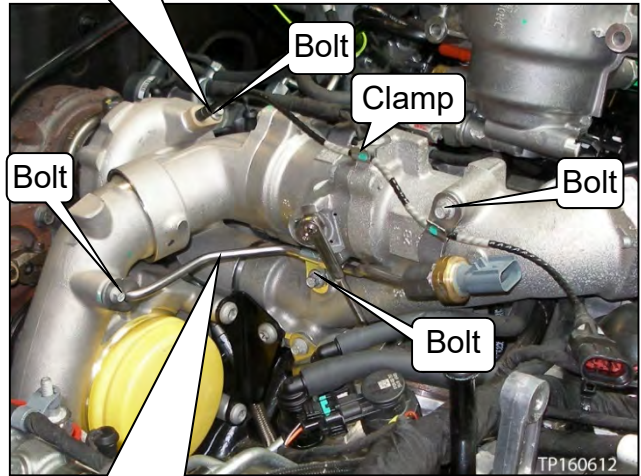

Figure 52

Low pressure turbocharger boost pressure sensor tube

39. Remove the T45 TORX® bolt (see Figure 53).

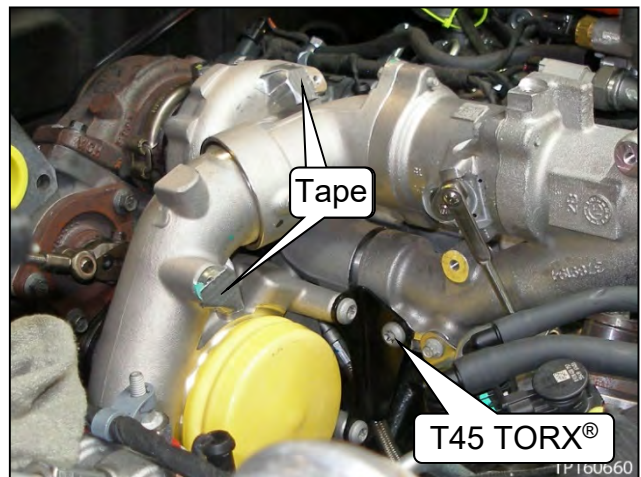

Figure 53

40. Unfasten the oil drain line bolt (see Figure 54).

41. Remove the high pressure turbocharger assembly from the vehicle.

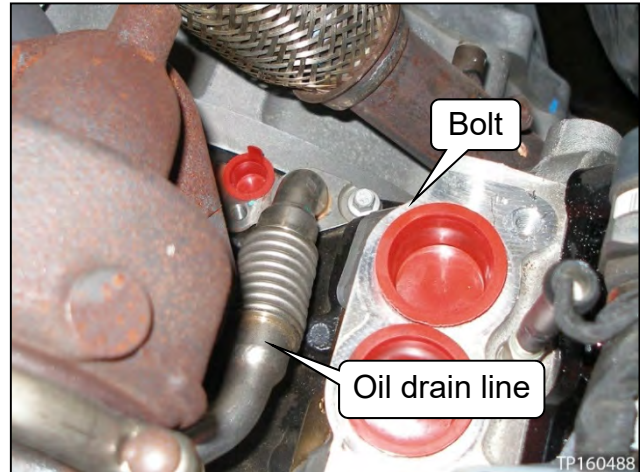

Figure 54

42. Cover the following openings:

- Oil drain line-to-block hole
- Low pressure turbocharger exhaust port
- Low pressure turbocharger outlet
 - See Figure 55 and Figure 56 for all locations.

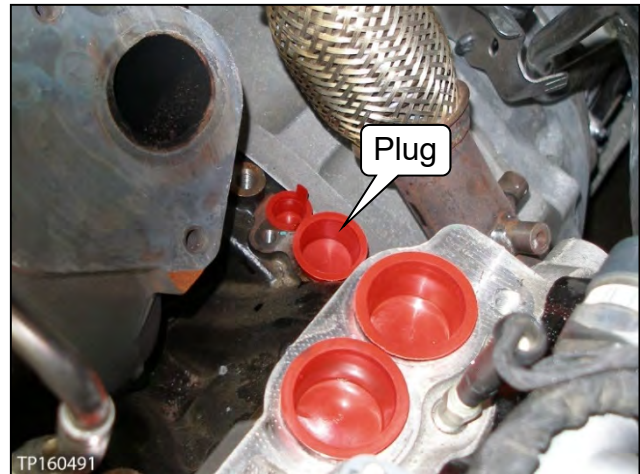

Figure 55

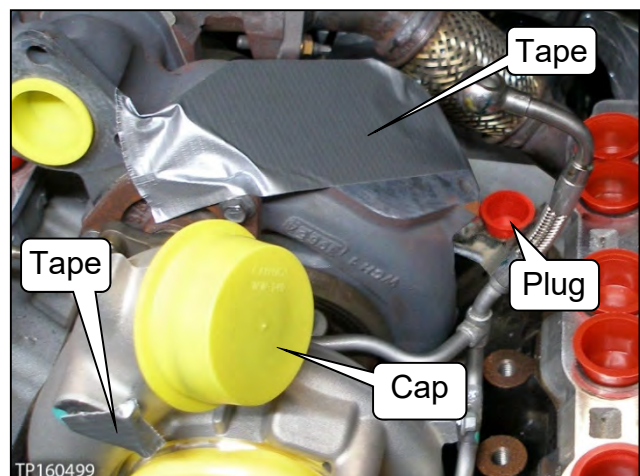

Figure 56

43. Remove the bolts, and then remove the oil drain line (see Figure 57).

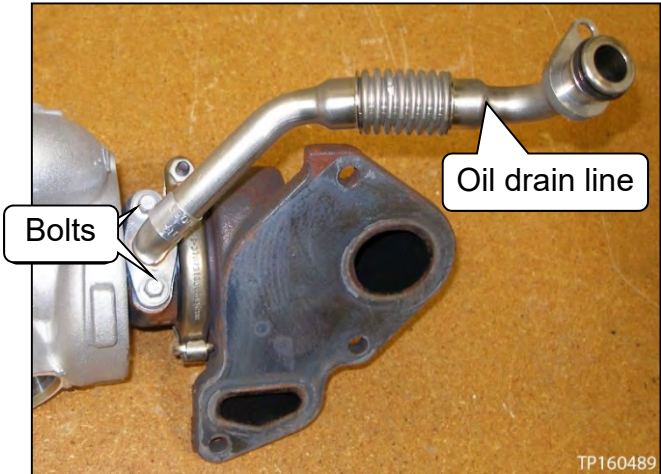

Figure 57

44. Remove the bolts, and then separate the high pressure turbocharger from the turbocharger compressor outlet connection assembly (see Figure 58 and Figure 59).

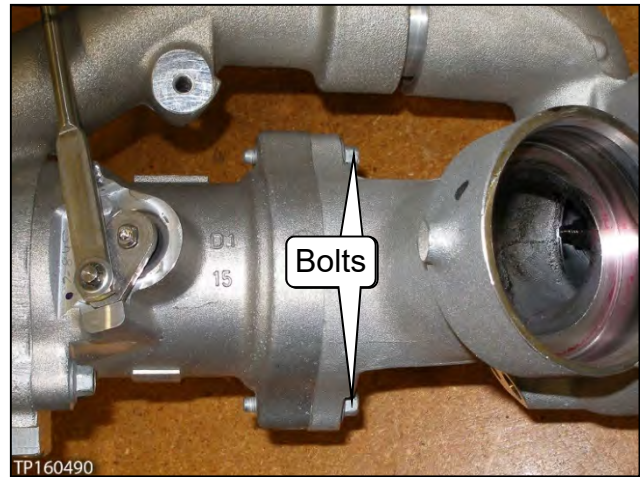

Figure 58

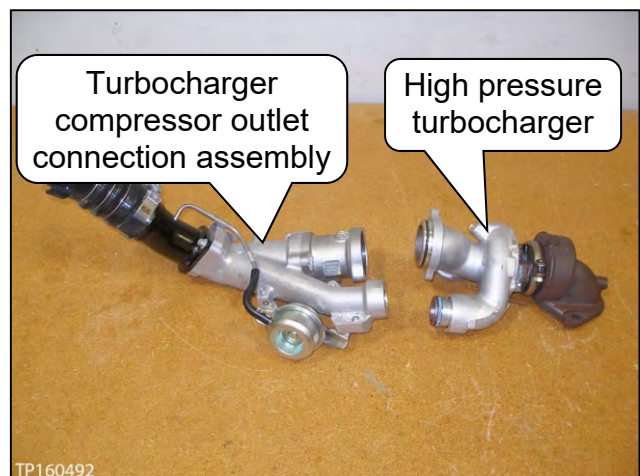

Figure 59

Install High Pressure Turbocharger Assembly

1. Remove the high pressure turbocharger from its packaging, and then install tape where shown in Figure 60.

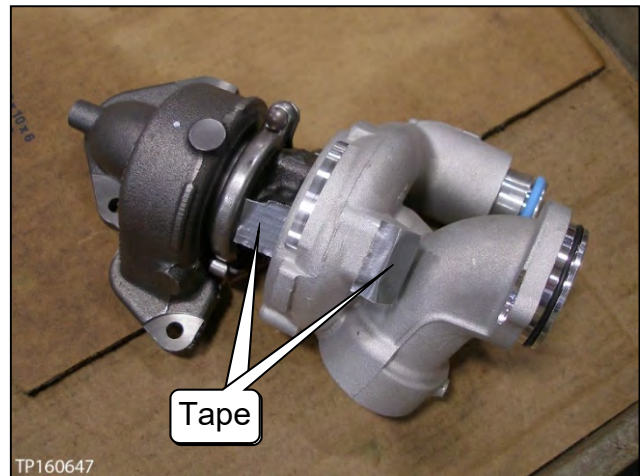

Figure 60

2. Install the oil drain line (see Figure 61).
 - Use a new gasket and O-ring.
 - Cummins O-ring P/N: 3029820.

NOTE: All parts in the parts kit are labeled with Cummins part numbers. See **Parts Cross Reference List**.

 - Bolt torque: 9.8 N•m (1.0 kg-m, **87 in-lbs**)
 - Coat the O-ring with clean engine oil.

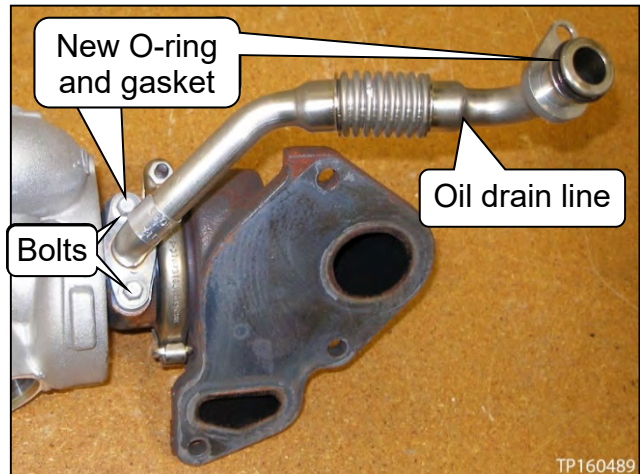

Figure 61

3. Remove the cap, tape, and plug shown in Figure 62.
4. Replace the low pressure turbocharger's O-ring with a new one (see Figure 62).
 - Cummins P/N: 2835314.
 - See **Parts Cross Reference List**.
 - Coat the O-ring with P80[®] Emulsion (see **PARTS INFORMATION** and the **CAUTION** below it).

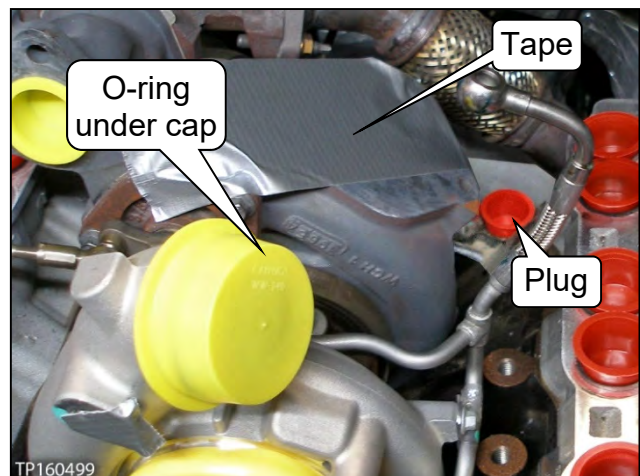

Figure 62

5. Position the new high pressure turbocharger on the low pressure turbocharger (see Figure 63).
 - a. Install a new gasket.
 - A gasket fits between the two turbochargers.
 - b. Apply suitable anti-seize to the bolts' threads.
 - c. Loosely install the three (3) bolts (see Figure 64).

NOTE: There are extra bolts in the parts kit. Replace as needed.

CAUTION: Do not lean on the stage 2 fuel filter assembly at any time while it is unbolted (see Figure 63).

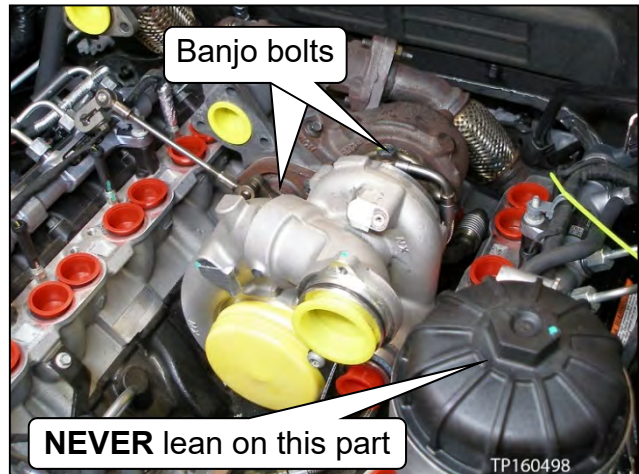

Figure 63

6. Remove the tape, and then install both banjo bolts finger tight with new copper gaskets (see Figure 64).
 - Do not use the old copper gaskets.
 - The “low pressure” banjo bolt cannot be seen in Figure 63 or Figure 64.
 - Do not torque the banjo bolts at this time.

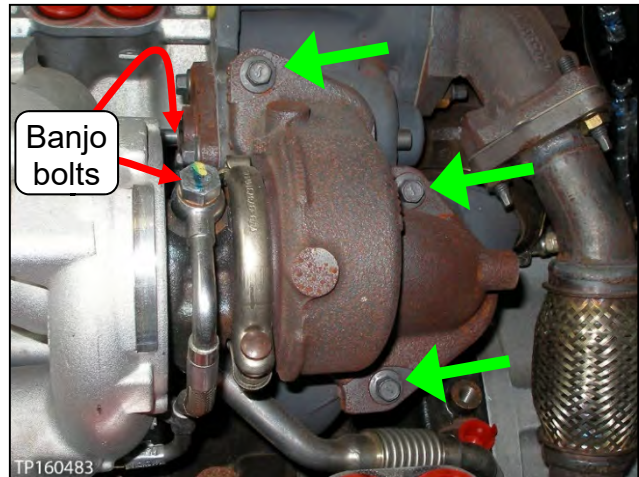

Figure 64

7. Fully insert the oil drain line with new O-ring into the engine block, and then install the bolt (see Figure 65).
 - Make sure the O-ring is coated with engine oil.
 - Bolt torque: 9.8 N•m (1.0 kg-m, **87 in-lbs**)

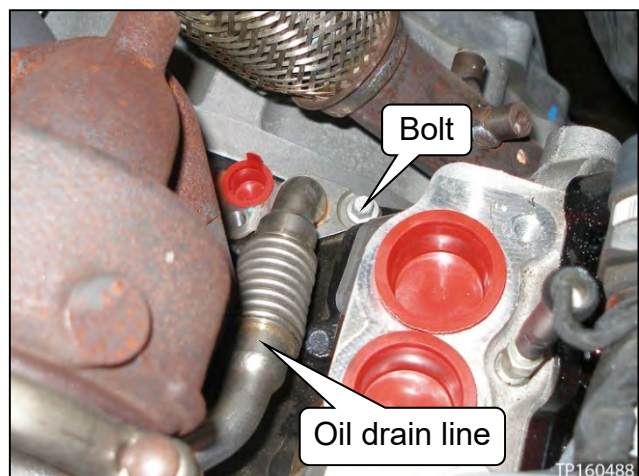

Figure 65

8. Install the turbocharger compressor outlet connection assembly.
 - a. Remove the cap and plug from the high pressure turbocharger.
 - b. Coat the O-rings with P80[®] Emulsion (see **CAUTION** under **PARTS INFORMATION**).
 - c. Put the turbocharger compressor outlet connection assembly in place.
 - d. Install two new bolts (see Figure 66).
 - Do not reuse the old bolts. The new bolts come with a thread lock coating.
 - e. Install the T45 TORX[®] bolt finger tight (see Figure 66).
 - There are extra TORX[®] bolts in the parts kit. Replace this bolt as needed.

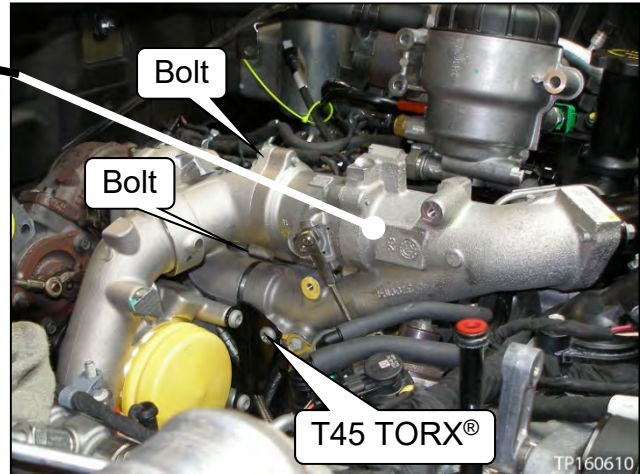

Figure 66

9. Torque the three (3) bolts shown in Figure 67.
 - Bolt torque: 32 N•m (3.3 kg-m, **24 ft-lbs**)

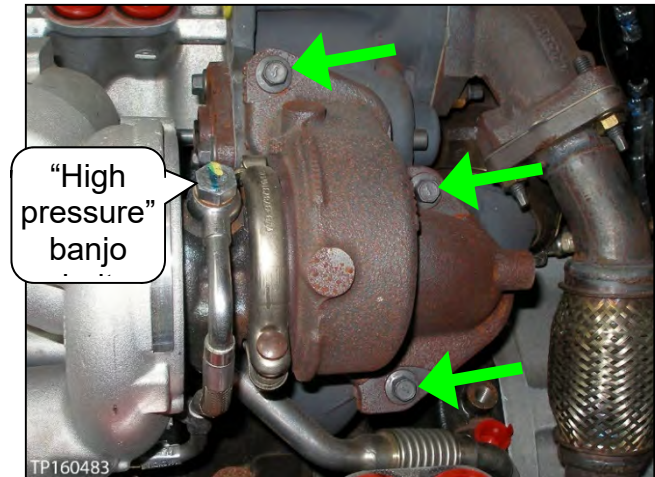

Figure 67

10. Torque the banjo bolts (see Figure 67 and Figure 68).
 - “High Pressure” banjo bolt torque: 22 N•m (2.2 kg-m, **16 ft-lbs**)
 - “Low Pressure” banjo bolt torque: 34 N•m (3.5 kg-m, **25 ft-lbs**)

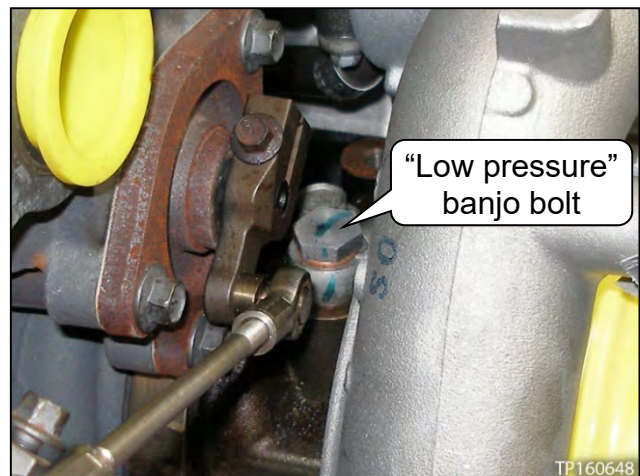

Figure 68

11. Torque the T45 TORX® bolt, and two (2) new bolts shown in Figure 69.

- T45 TORX® torque: 18 N•m (1.8 kg-m, **13 ft-lbs**)
- Bolt torque: 10 N•m (1.0 kg-m, **84 in-lbs**)

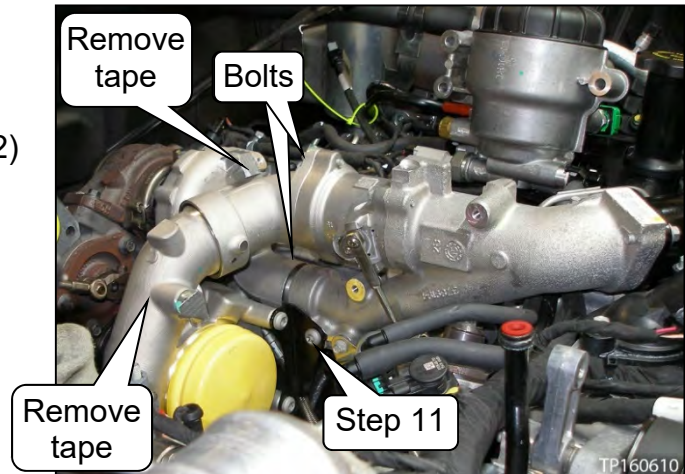

Figure 69

12. Install the low pressure turbocharger boost pressure sensor tube (see Figure 70).

- Remove the tape (see Figure 69).
- Replace the O-ring with a new one and coat it with P80® Emulsion.
 - See **PARTS INFORMATION** and the **CAUTION** below it.
- Cummins P/N: 3779750
 - See **Parts Cross Reference List**.
- Bolt **A** torque: 10.2 N•m (1.0 kg-m, **96 in-lbs**)

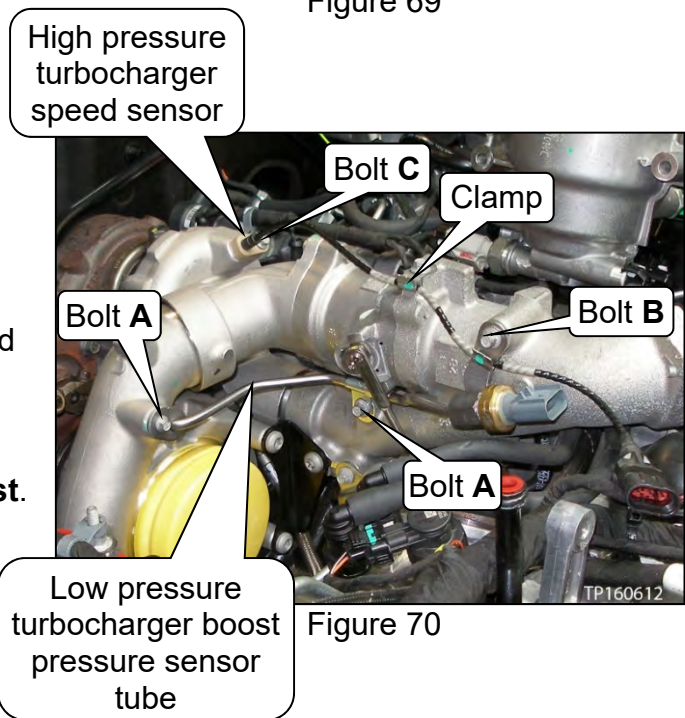

Figure 70

13. Install the high pressure turbocharger speed sensor (see Figure 70).

- Remove the tape (see Figure 69).
- Replace the O-ring with a new one and coat it with P80® Emulsion.
 - Cummins P/N: 3787623
 - See **PARTS INFORMATION** and the **CAUTION** below it.
- Bolt **B** torque: 10.2 N•m (1.0 kg-m, **96 in-lbs**)
- Bolt **C** torque: 5.5 N•m (0.56 kg-m, **49 in-lbs**)

14. Remove the cap from the low pressure turbocharger, and then install the air inlet connection assembly (see Figure 71).

- Clamp screw torque: 4.5 N•m (0.46 kg-m, **40 in-lbs**)

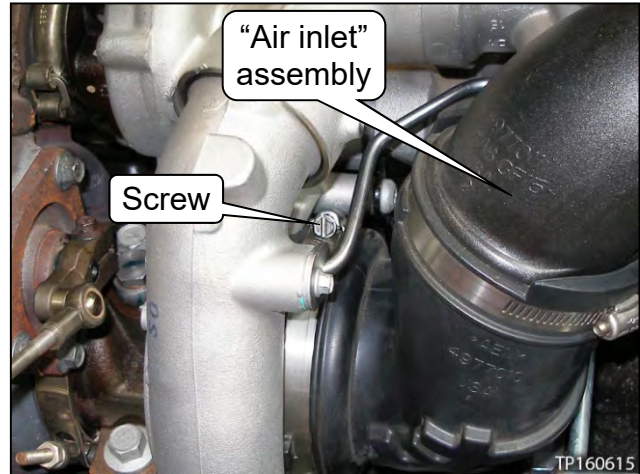

Figure 71

- The air inlet connection assembly is properly mated to the low pressure turbocharger when the notch is seated in the cut-out (see Figure 72 and Figure 73).

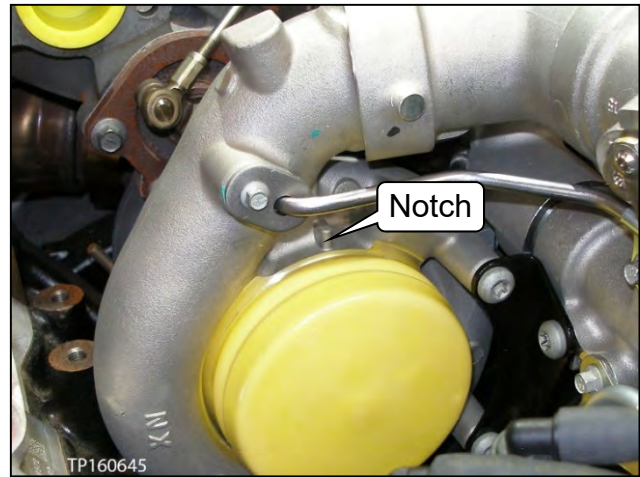

Figure 72

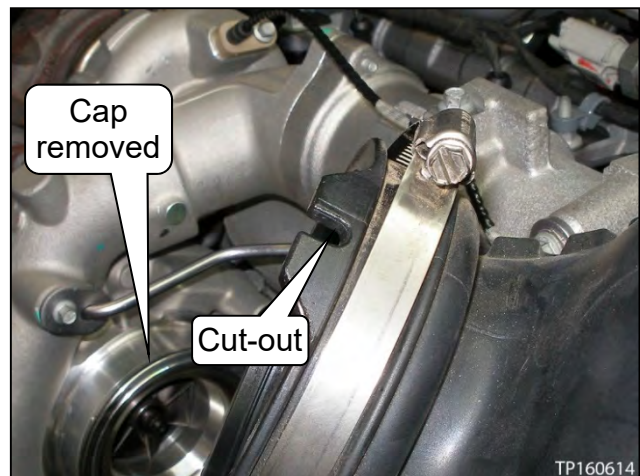

Figure 73

15. Connect the two (2) connectors (see Figure 74).

- Low pressure turbocharger boost pressure sensor
- High pressure turbocharger speed sensor

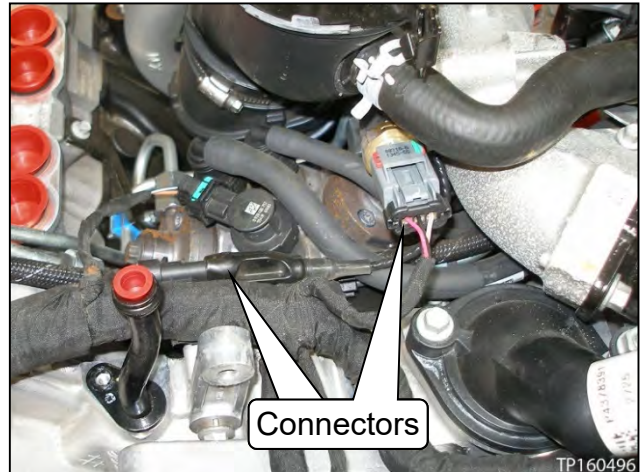

Figure 74

16. Connect the vacuum hose (see Figure 75).

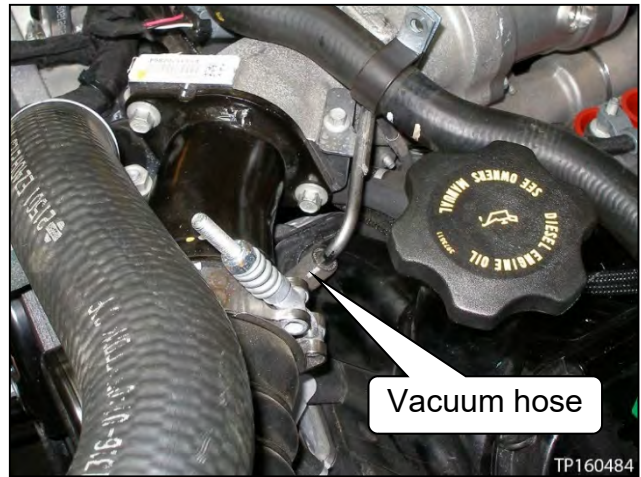

Figure 75

17. Remove the tape, and then connect the charge-air cooler tube to the charge-air cooler outlet hose (see Figure 76).

- Clamp nut torque: 10 N•m (1.0 kg-m, **84 in-lbs**)

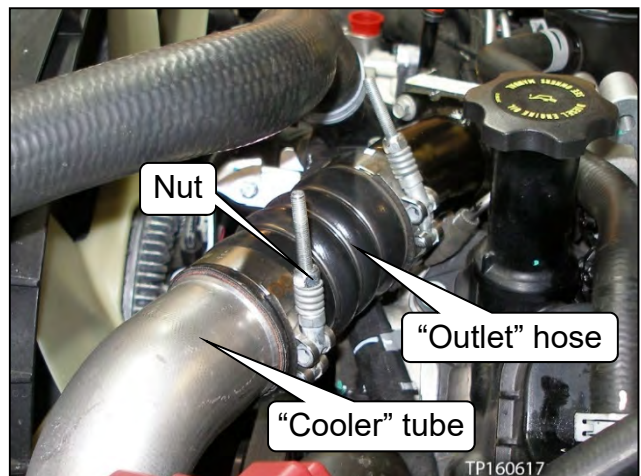

Figure 76

18. Remove the plug, and then remove the EGR bypass valve coolant tube (see Figure 77).

- Replace both O-rings with new ones (# 4977258), and then coat them with P80® Emulsion.
 - See the **Parts Cross Reference List, PARTS INFORMATION,** and the **CAUTION** below it.

19. Fully insert the EGR bypass valve coolant tube to the intake manifold (see Figure 78).

- The upper O-ring will hold the EGR bypass valve coolant tube in place.

NOTE: The EGR bypass valve coolant tube does not need to be in the exact position. The final position will be set in step 25.

NOTE: Make sure the paint mark(s) are facing upward as shown in Figure 77 once the intake manifold is installed.

- For additional reference, also see page 37, Figure 87.

20. Replace the two water transfer connection tube O-rings with new ones (see Figure 78).

- Coat the O-rings (# 5266152) with P80 Emulsion.
 - See the **Parts Cross Reference List, PARTS INFORMATION** and the **CAUTION** below it.

21. Install all O-ring gaskets in the intake manifold (see Figure 78).

- Make sure the surfaces the O-ring gaskets come in contact with are clean.
- Make sure all O-rings are in place and properly seated (see Figure 79).

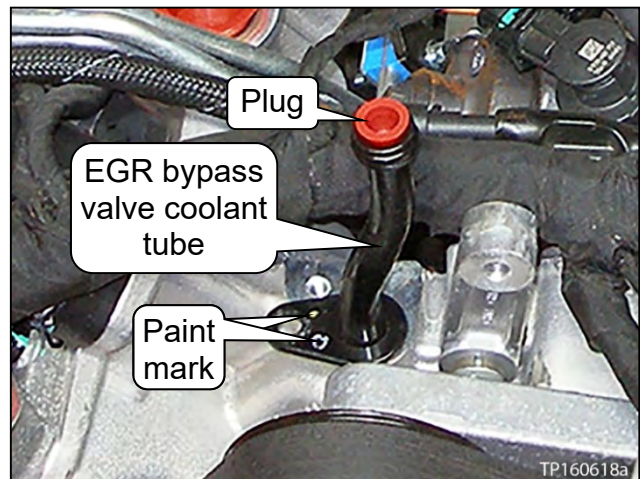

Figure 77

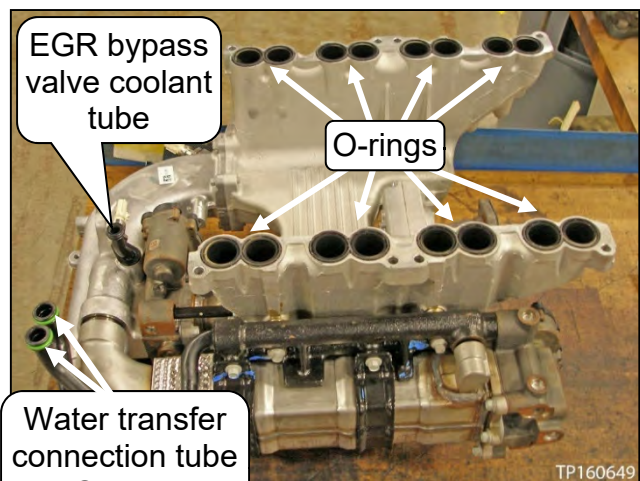

Figure 78

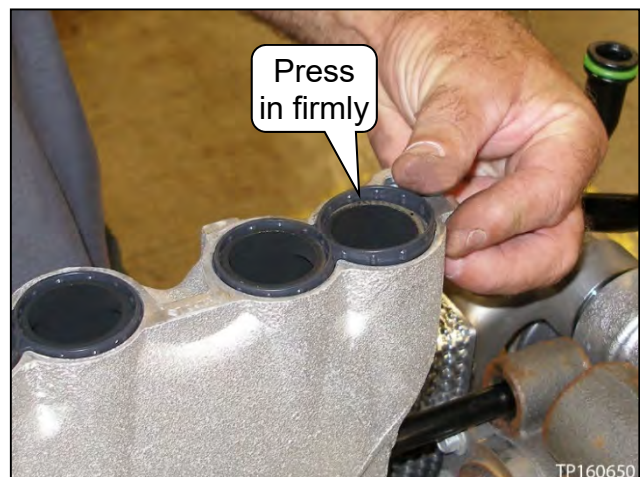

Figure 79

22. Replace the EGR bypass tube gasket with a new one (see Figure 80).

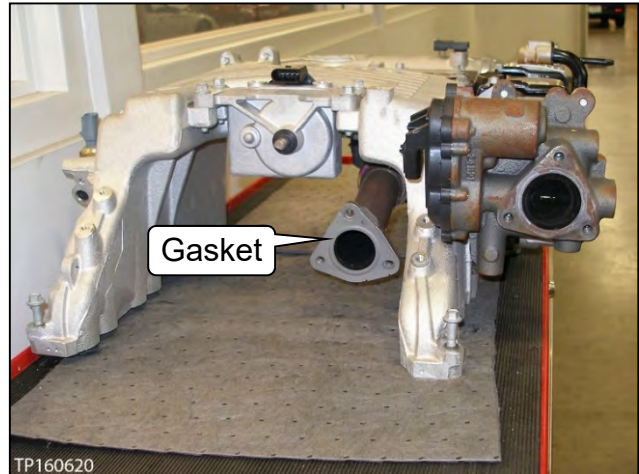

Figure 80

23. Install all eight (8) intake manifold bolts in place (see Figure 81).

- Use new bolts from the parts kit. These bolts come with O-rings. They are to hold the bolts in place.
- Figure 81 does not show the four bolts on the other side of the intake manifold.

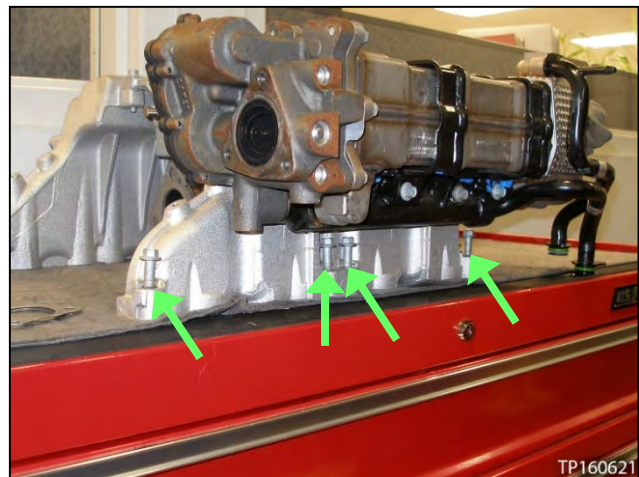

Figure 81

- Push down enough for the O-rings to hold the bolts in place, but not enough for the bolts to stick out the bottom (see Figure 82).

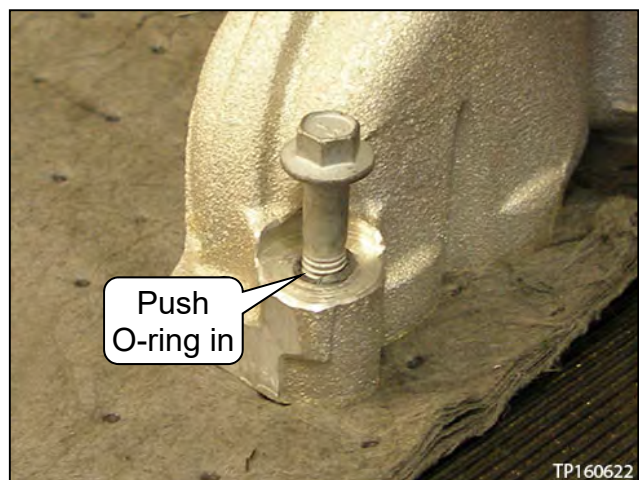

Figure 82

24. Remove all plugs shown in Figure 83 now.

- Do not remove the cap on the air inlet connection assembly.
- Plugs can be reused. Put them back in Kit J-54423 (see page 3).
- Position the rotary turbine control valve linkage as far as possible on the driver side of the EGR bypass flange.

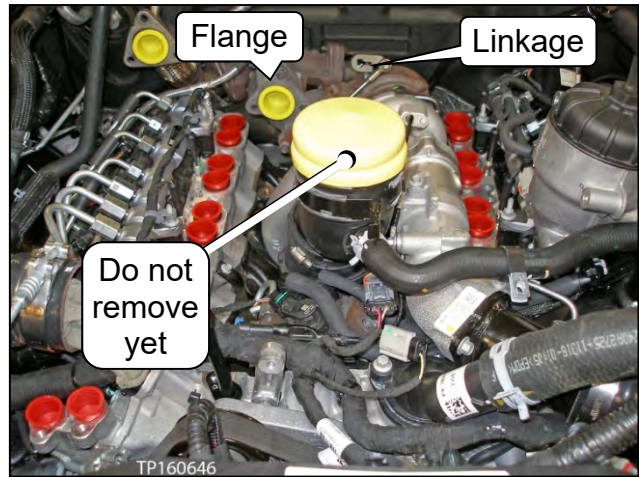

Figure 83

25. Put the intake manifold in place (no picture shown).

- Make sure:
 - All intake manifold O-ring gaskets are properly seated.
 - The engine control harness is not being pinched by the intake manifold.
 - The EGR bypass coolant tube and both water transfer connection tubes are properly positioned and inserted (see next page, Figure 87).
 - All bolts thread in/start by hand.

CAUTION: Due to its weight and location, use proper lifting equipment or assistance when lifting and installing the intake manifold assembly.

26. Torque the bolts.

- Bolt torque: 18 N•m (1.8 kg-m, **13 ft-lbs**)
- See Figure 84 for torque sequence.

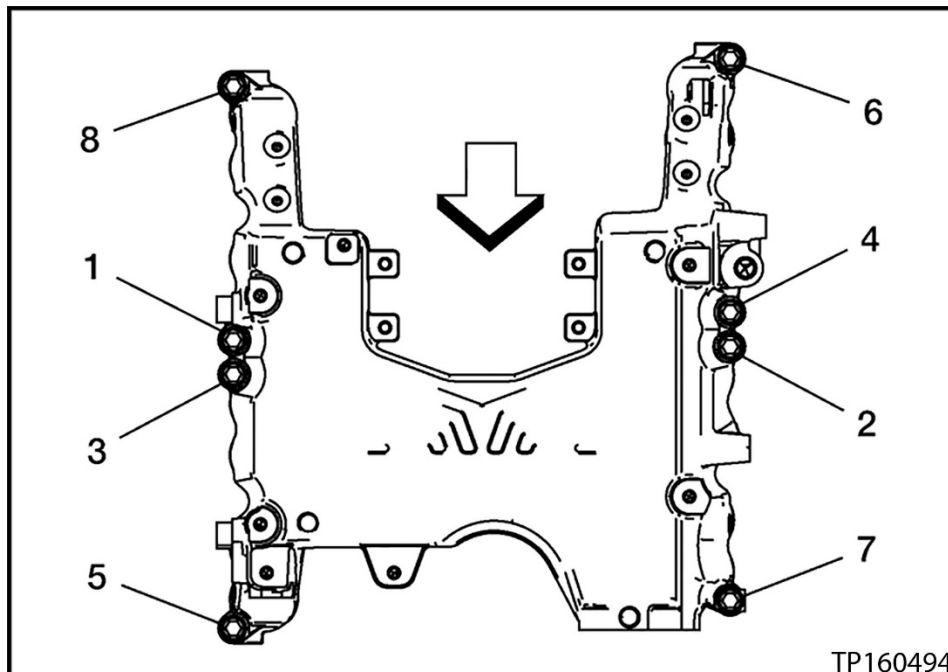

Figure 84

27. Connect the EGR temperature sensor connector (see Figure 85 and Figure 86).

- This sensor is located under the front of the intake manifold.

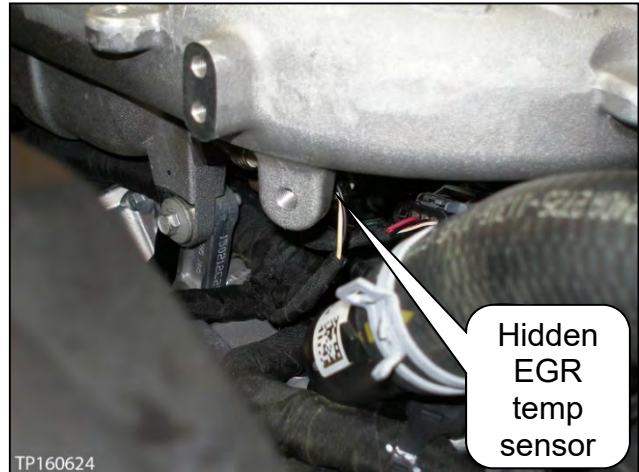

Figure 85

- Figure 86 shows the EGR temperature sensor connector when viewed between the front of the intake manifold and the air inlet connection assembly.

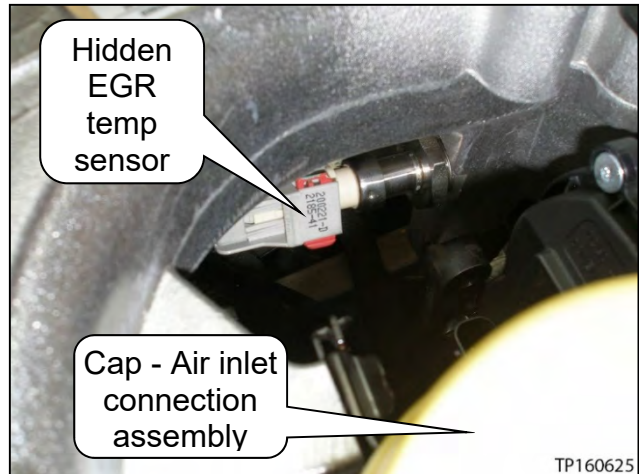

Figure 86

28. Install the bolts for the EGR bypass coolant tube and both water transfer connection tubes (see Figure 87).

- Bolt torque: 7.4 N•m (0.75 kg-m, **65 in-lbs**)

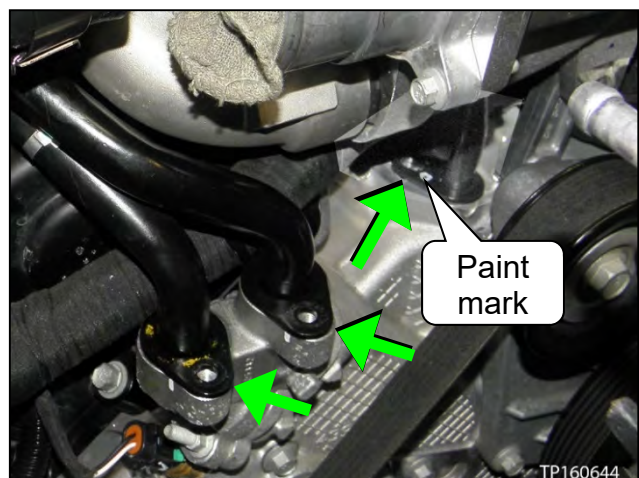

Figure 87

29. Install the air intake connection bolt (see Figure 88).

- Bolt torque: 18 N•m (1.8 kg-m, **13 ft-lbs**)



Figure 88

30. Install the air inlet connection bolt (see Figure 89).

- Bolt torque: 18 N•m (1.8 kg-m, **13 ft-lbs**)

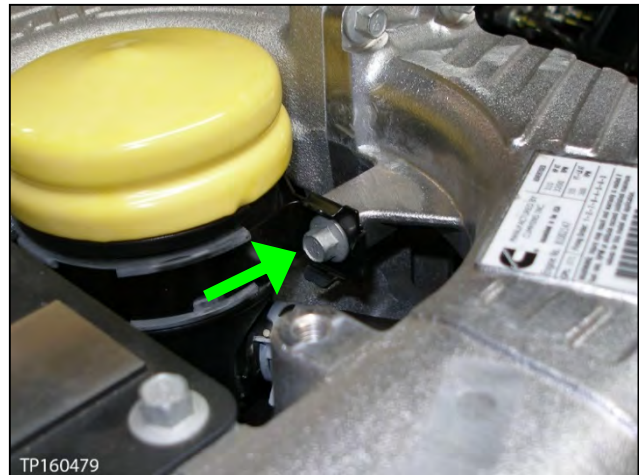

Figure 89

31. Remove the tape, and then connect the air outlet hose to the air intake connection (see Figure 90).

- Clamp nut torque: 10 N•m (1.0 kg-m, **84 in-lbs**)



Figure 90

32. Install the three (3) EGR valve inlet pipe bolts (see Figure 91).

- Bolt torque: 23 N•m (2.3 kg-m, **17 ft-lbs**)
- Replace the gasket. Do not reuse the old gasket.

NOTE: There are extra bolts in the parts kit. Replace as needed.

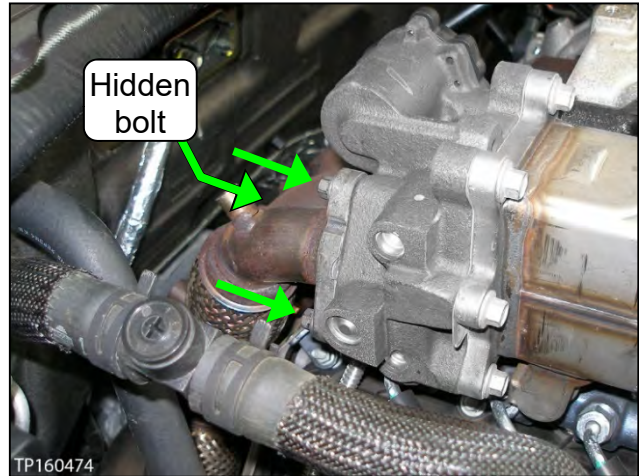

Figure 91

33. Install the three (3) EGR bypass tube bolts (see Figure 92).

- Bolt torque: 18 N•m (1.8 kg-m, **13 ft-lbs**)
 - Apply suitable anti-seize to the bolts' threads before installing.
 - Make sure the gasket has been replaced (see page 35, step 22). Do not reuse the old gasket.

NOTE: There are extra bolts in the parts kit. Replace as needed.

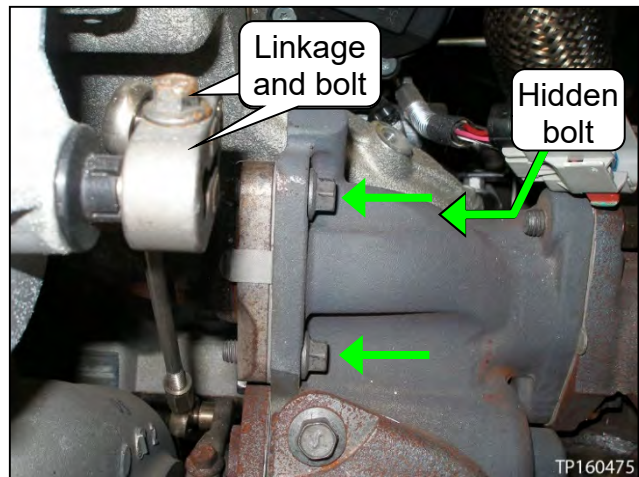

Figure 92

34. Mount and secure the rotary turbine control valve upper linkage (see Figure 92 and Figure 93).

- Bolt torque: 10 N•m (1.0 kg-m, **84 in-lbs**)

35. Connect the EGR valve actuator connector (see Figure 93).

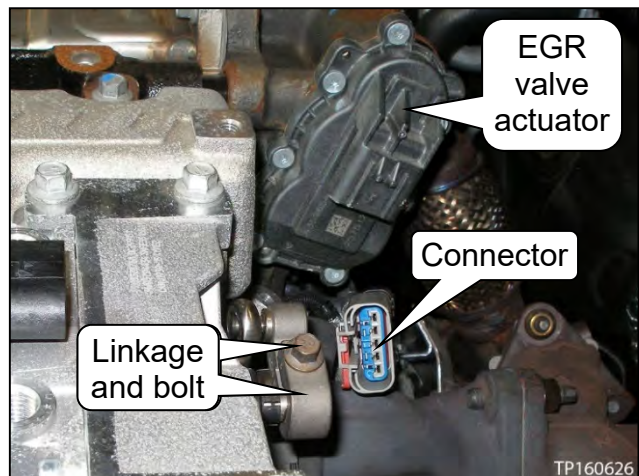

Figure 93

36. Install the exhaust pressure sensor tube (see Figure 95 and Figure 96).

- Replace the O-ring with a new one.
 - Coat the O-ring with P80 Emulsion (see **CAUTION** under **PARTS INFORMATION**).
- Fully insert the tube in the intake manifold first.
- Bolt 1 and 2 torque: 7 N•m (0.7 kg-m, **62 in-lbs**)
- Flare nut torque: 19 N•m (1.9 kg-m, **14 ft-lbs**)

NOTE: The flare nut torque specification is an adjusted value when using a torque wrench 11-15 inches long and a flare nut type “crow’s foot” 1-1.5 inches long.

- The “crow’s foot” is measured from the center of the square hole to the center where the flare nut fits (see Figure 94).

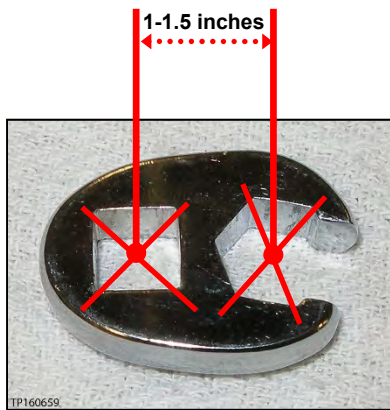

Figure 94

37. Mount the stage 2 fuel filter assembly with the one bolt (see Figure 97).

- At this time, install the bolt finger tight.

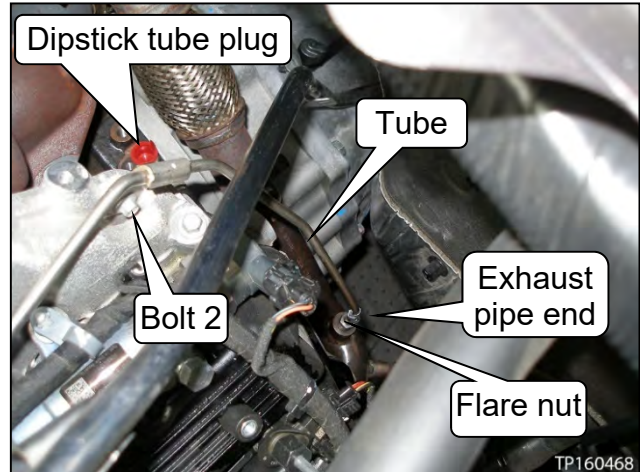

Figure 95

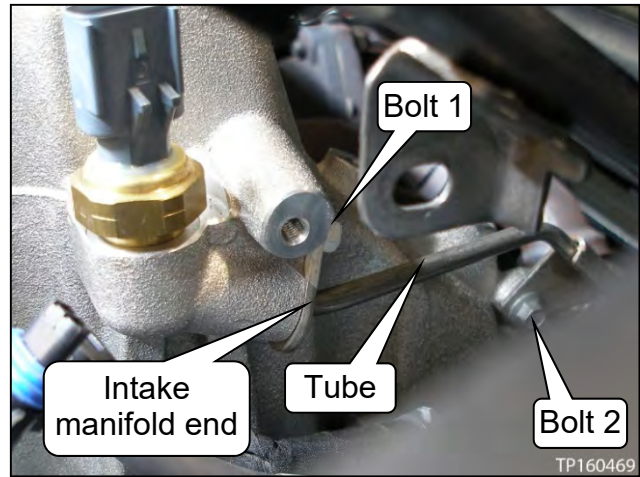

Figure 96

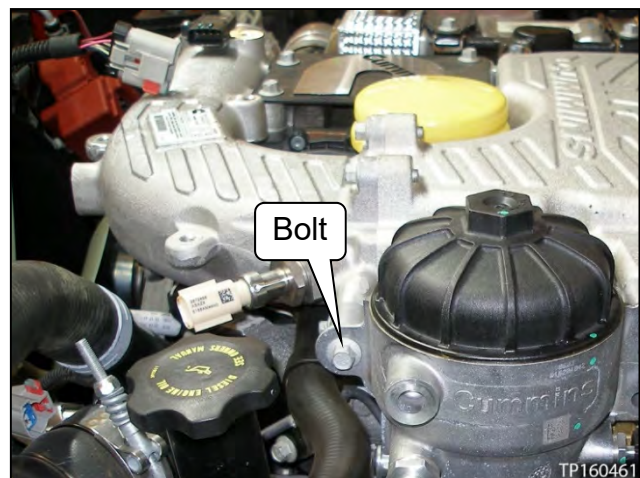

Figure 97

38. Install the oil dipstick with tube.

- a. Remove the plug (see Figure 98).
- b. Install a new O-ring on the oil dipstick tube.
 - Coat the O-ring with engine oil.
- c. Insert the oil dipstick tube into the first engine block hole.
- d. Guide the oil dipstick tube further into the first hole at an angle, and then into the second engine block hole until fully seated (see Figure 98, Figure 99, and Figure 101).
- e. To verify the oil dipstick tube is properly installed, check the engine oil level.
 - If the oil level registers the same as recorded on page 13, step 14, the oil dipstick tube is properly installed.
 - If NO oil registers, the oil dipstick tube missed the second engine block hole. Remove and correctly install.

CAUTION: The oil dipstick tube goes through the converter housing area before entering the second engine block hole. It is possible to insert the oil dipstick tube in the converter housing area and not the second engine block hole.

- f. When the oil dipstick tube is fitted correctly, install the bolt (see Figure 100).
 - Bolt torque: 7.4 N•m (0.75 kg-m, **65 in-lbs**)

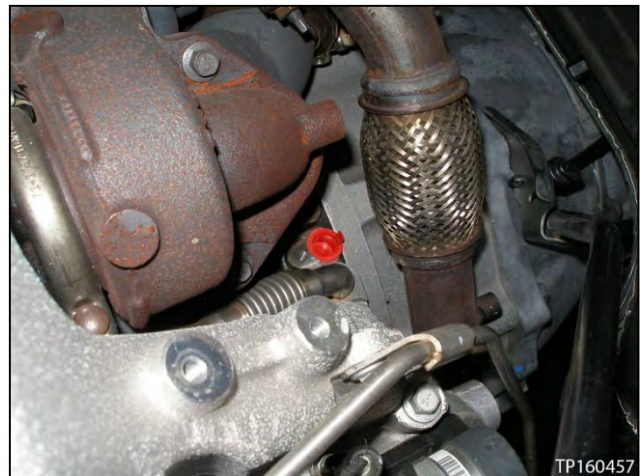

Figure 98

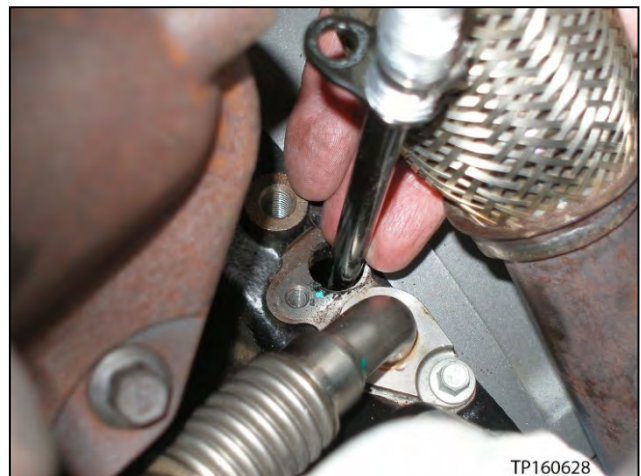

Figure 99

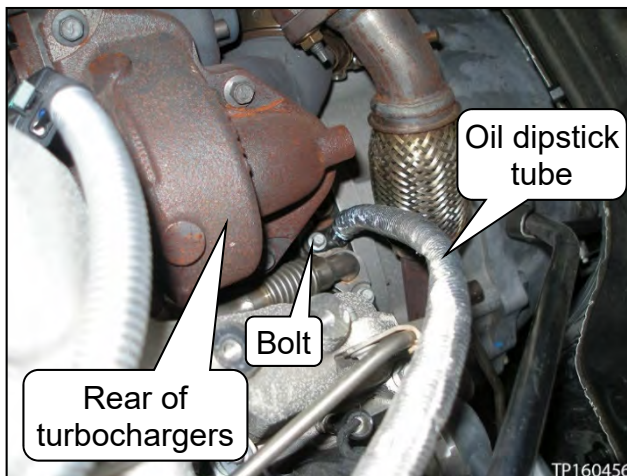

Figure 100

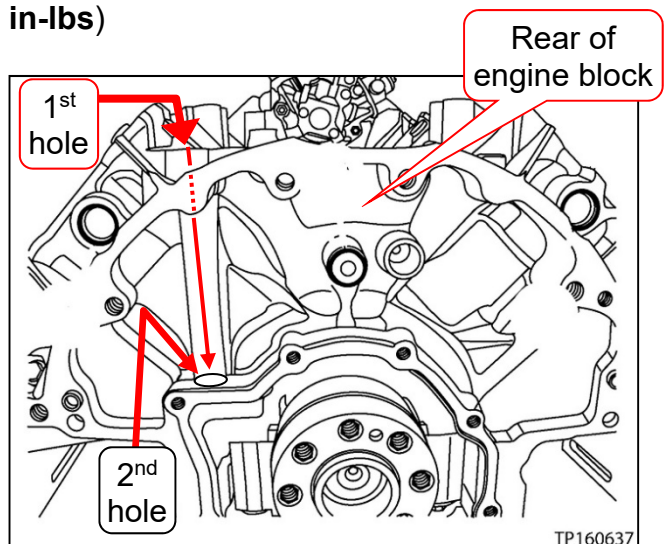

Figure 101

39. Carefully cut, and then remove the tie strap (see Figure 102).

40. Remove the plug and cap, and then connect the fuel line to the stage 2 fuel filter assembly (see Figure 102, Figure 103, and Figure 104).

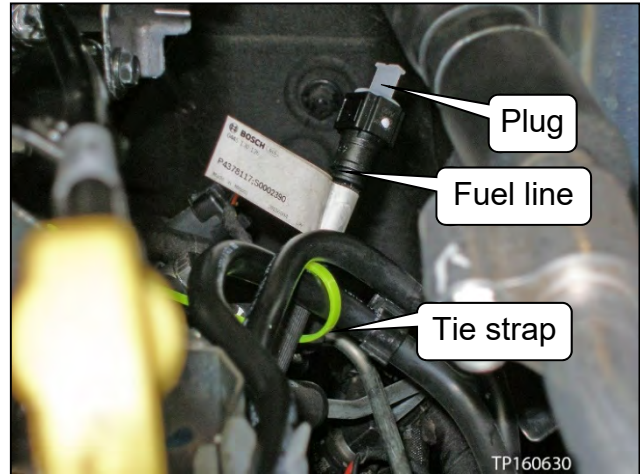

Figure 102

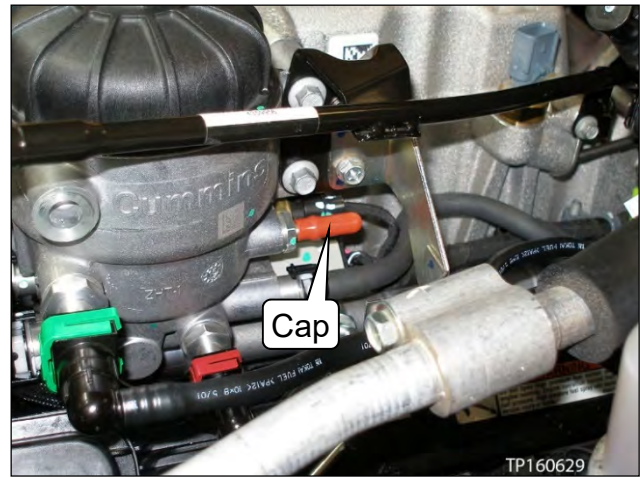

Figure 103

41. Install the four (4) bolts. See Figure 104.

NOTE: Two of the bolts also secure the stage 2 fuel filter assembly.

- Stage 2 fuel filter assembly bolts torque: 18 N•m (1.8 kg-m, **13 ft-lbs**)
 - Also apply the torque above to the bolt shown on page 40, Figure 97.
- Remaining bolts torque: 7.4 N•m (0.75 kg-m, **65 in-lbs**)

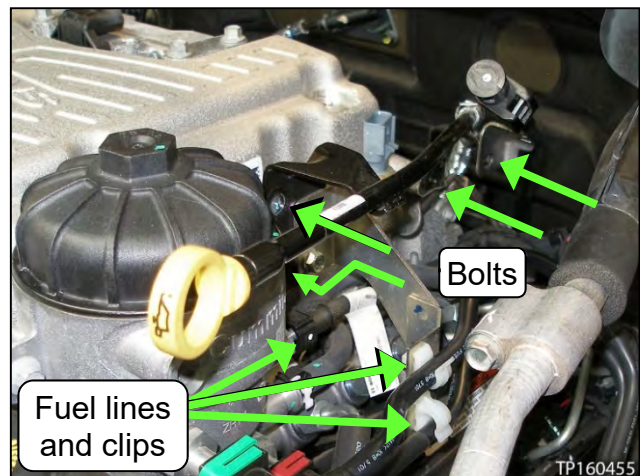

Figure 104

42. Snap the two fuel lines in their clips (see Figure 104).

43. Connect the breather tube to the valve cover, and then install the clamp and bolt (see Figure 105).

- Bolt torque: 7.4 N•m (0.75 kg-m, **65 in-lbs**)

44. Route the engine control harness, and then connect and lock all the related connectors (see Figure 106).

- Figure 107 - Figure 109 shows how to secure the different types of connectors.

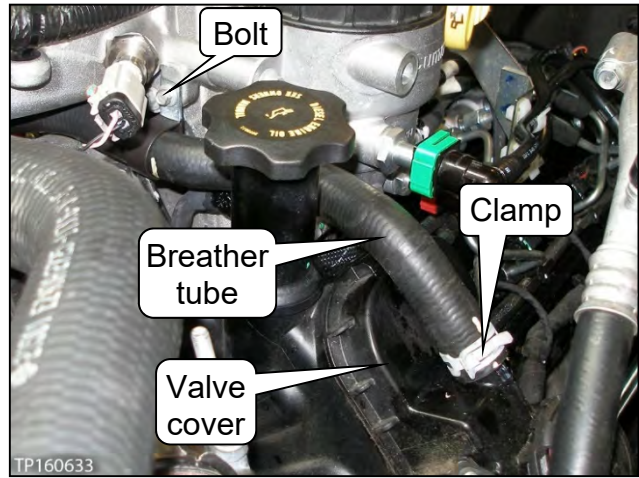

Figure 105



Figure 106

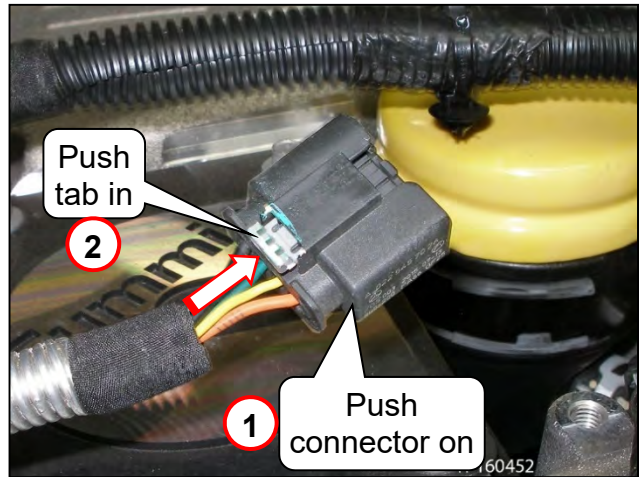

Figure 107

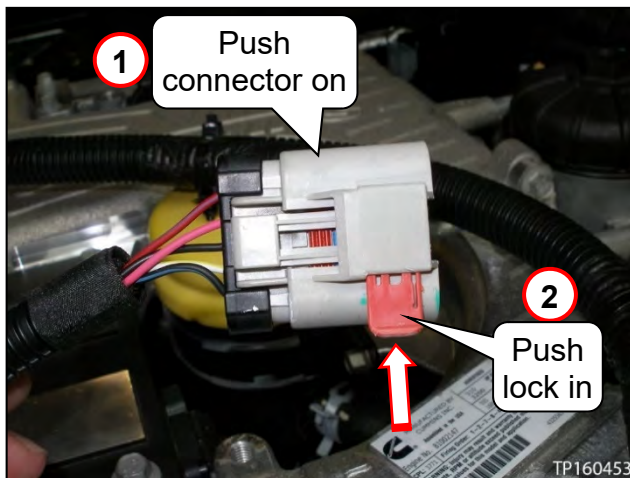

Figure 108



Figure 109

45. Remove the cap, install the air filter element, and then install the air duct with upper air cleaner case (see Figure 110 and Figure 111).

- Make sure to connect the mass air flow sensor and turbocharger compressor intake pressure/temperature sensor.



Figure 110

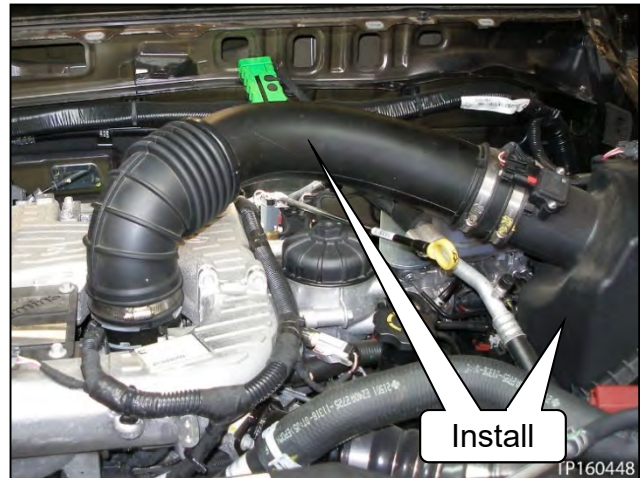

Figure 111

46. Install all three (3) heat shields, center heat shield last (see Figure 112).

- The vehicle will need to be raised to access some of the bolts.
- Bolt torque: 7.4 N•m (0.75 kg-m, **65 in-lbs**)

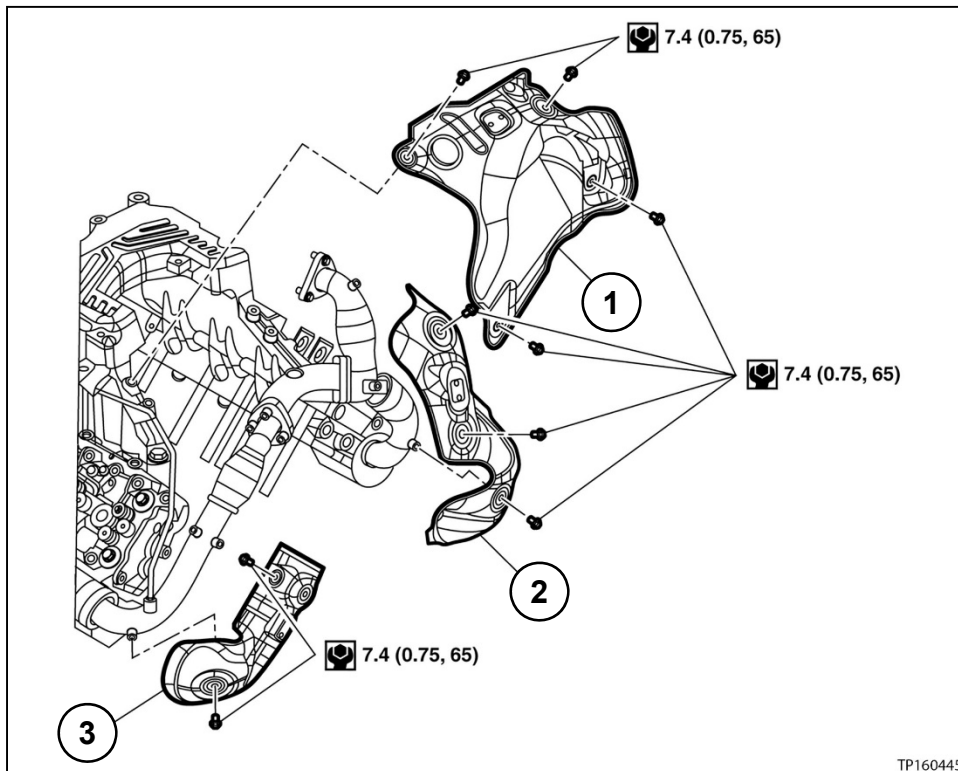

Figure 112

1. Center heat shield

2. RH heat shield

3. LH heat shield

47. Install the cowl.

a. Install the cowl top extension with the eight (8) bolts, and then install both drain pipes (see Figure 113, # 3 & 5, and Figure 115 and Figure 116).

- Bolt torque: 5.5 N•m (0.56 kg-m, **49 in-lbs**)

b. Install the wiper drive assembly (see Figure 114).

- Bolt torque: 5.74 N•m (0.59 kg-m, **51 in-lbs**)
- Torque the bolts in the order shown in Figure 114.

c. Install the cowl top extension bracket (see Figure 113, # 4).

- Bolt torque: 5.5 N•m (0.56 kg-m, **49 in-lbs**)

d. Install the cowl top cover (see Figure 113, # 1).

NOTE: Install the cowl top side trim cover(s) separately as needed (see Figure 113, # 2).

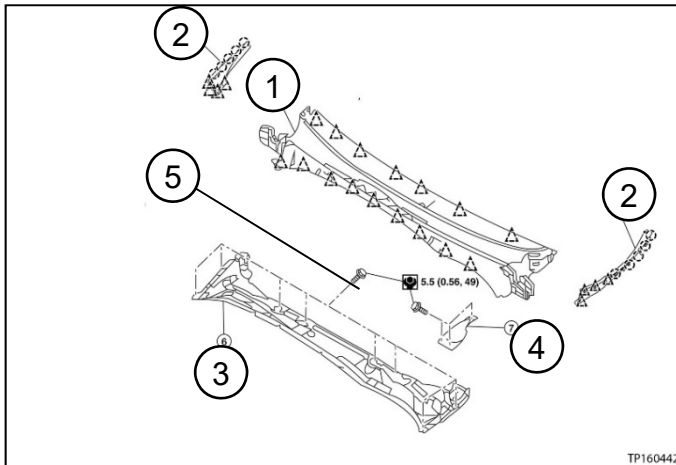

Figure 113

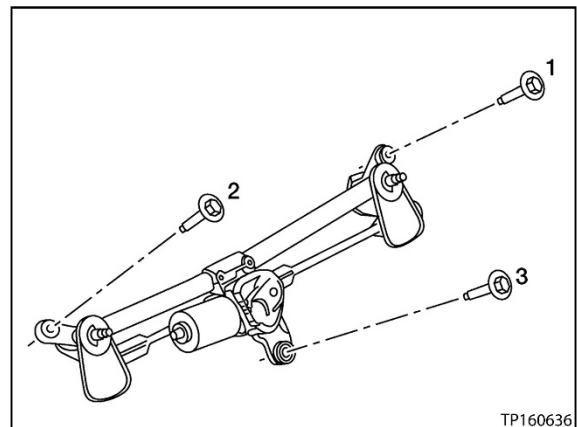

Figure 114

1. Cowl top cover

2. Cowl top side trim cover

3. Cowl top extension

4. Cowl top extension bracket

5. Cowl top extension bracket bolts

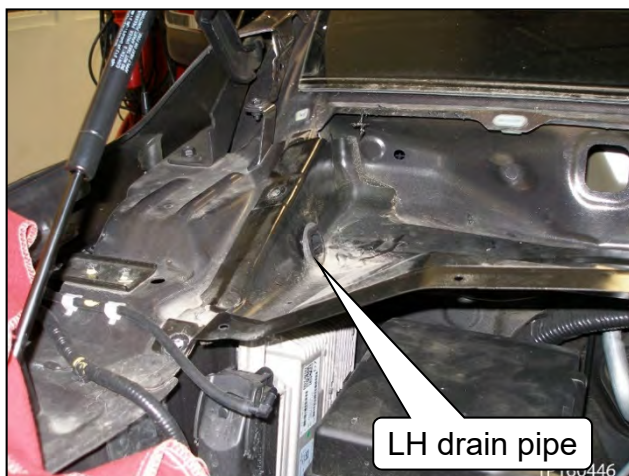

Figure 115

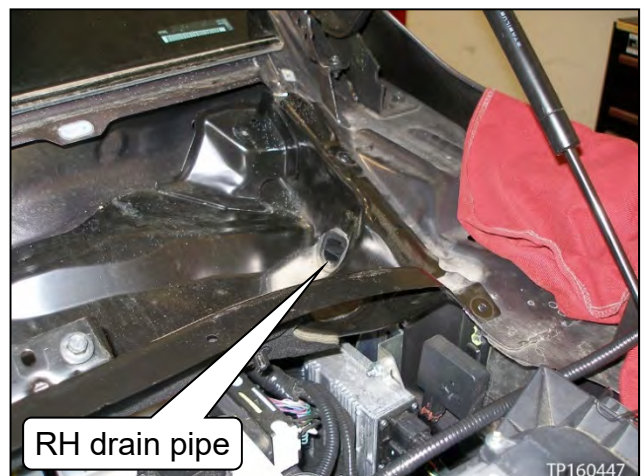

Figure 116

- e. Connect the washer nozzle supply hose (see Figure 117).

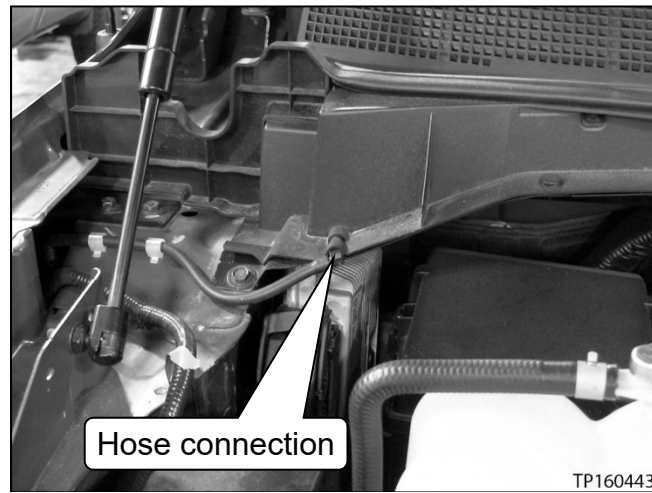

Figure 117

- f. Install the wiper arms with nuts and covers (see Figure 118).

- Nut torque: 23.6 N•m (2.4 kg-m, **17 ft-lbs**)

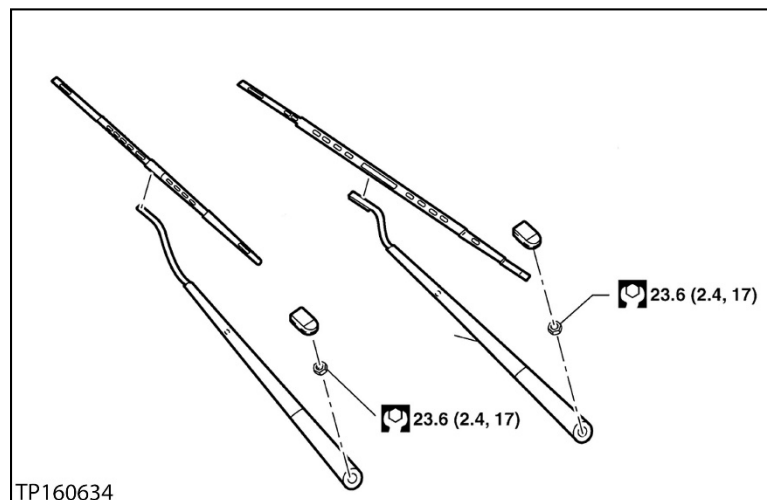

Figure 118

48. Connect the reservoir tank coolant line (see Figure 119).



Figure 119

49. Install the engine under cover (see Figure 120).

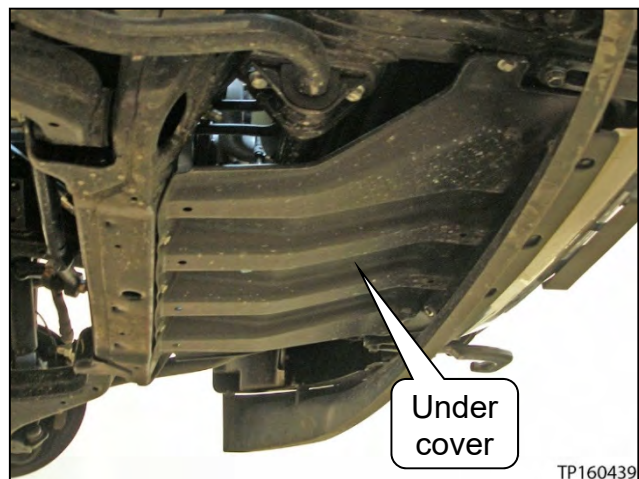

Figure 120

50. Connect all battery cables, both positive cables first.

- Refer to the ESM for battery removal: **ELECTRICAL & POWER CONTROL > POWER SUPPLY, GROUND & CIRCUIT ELEMENTS > REMOVAL AND INSTALLATION – BATTERY.**

51. Fill (prime) the primary fuel system.

- a. Turn the ignition ON, but do not start the engine.
- b. Wait for the primary fuel pump to stop running, and then turn the ignition OFF.
- c. Repeat step **a** and **b** a second time.

Check for fuel leaks.

52. Fill the cooling system.

- a. Set the heater controls to the full HOT and heater ON positions.
 - Turn the ignition ON with the engine OFF as necessary to activate the heater mode.
- b. Fill the cooling system with the coolant drained earlier.
 - Use Coolant Refill Tool J-45695-A, follow the tool's instructions.
- c. Remove Tool J-45695-A and top off the cooling system with coolant as necessary.
- d. Start and run the engine until it reaches normal operating temperature.

CAUTION: Do not allow the engine to exceed normal operating temperature or engine damage may occur.

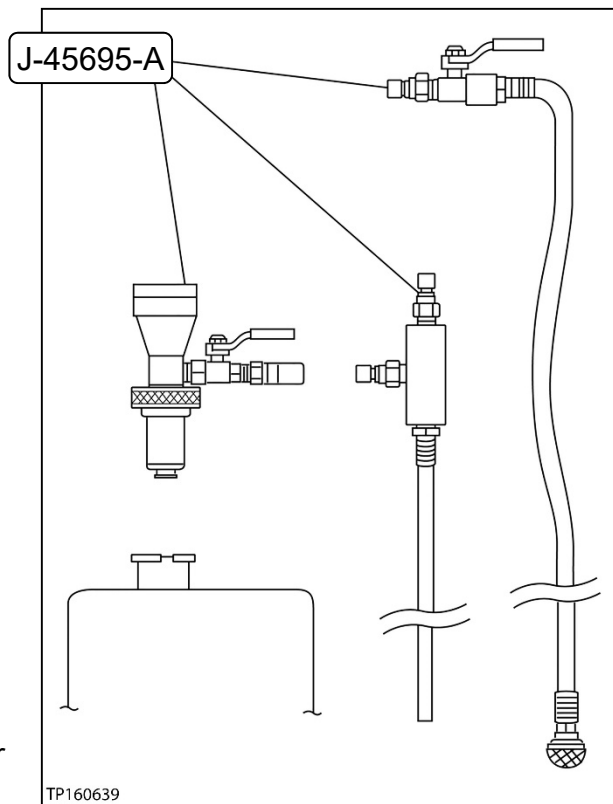

Figure 121

53. Check for fluid leaks (oil/fuel/coolant).

54. Install the tire and wheel assemblies.

- Lug nut's torque: 177 N•m (18 kg-m, **131 ft-lbs**)

55. Perform rotary turbine control valve actuator calibration.

- Refer to page 49, **Calibrate Rotary Turbine Control Valve Actuator**.

56. Reset/initialize electrical systems as needed.

- Refer to the Electronic Service Manual (ESM), section **ELECTRICAL & POWER CONTROL > POWER SUPPLY, GROUND & CIRCUIT ELEMENTS > BASIC INSPECTION > INSPECTION AND ADJUSTMENT > ADDITIONAL SERVICE WHEN REMOVING BATTERY NEGATIVE TERMINAL**, for a listing of systems that may lose settings or memory when disconnecting the 12V battery.

➤ This list often includes items such as audio, HVAC, power windows, clock, etc.

57. Test drive the vehicle, check for DTCs:

- Refer to the ESM, section **Engine Control System**, for further diagnostic information.

58. Close C-III plus.

59. Turn the ignition OFF.

60. Disconnect the plus VI from the vehicle.

Calibrate Rotary Turbine Control Valve Actuator

NOTE: The rotary turbine control valve actuator must be calibrated whenever the rotary turbine control valve linkage is replaced or dismantled at the UPPER linkage.

CAUTION: The rotary turbine control valve linkage must be replaced IF it is dismantled at the LOWER linkage or removed completely.

1. Connect the plus VI to the vehicle.
2. Turn the ignition ON with the engine OFF.
 - **The engine must not start or run during the recalibration procedure.**
3. Turn the hazard warning flashers ON.
4. Turn OFF all other vehicle electrical loads such as interior lights, HVAC, blower, rear defogger, audio, NAVI, seat heater, steering wheel heater, etc.
5. Turn ON the CONSULT PC.
6. Select CONSULT-III plus (open C-III plus).
7. Wait for the plus VI to be recognized / connected.
 - The serial number will display when the plus VI is recognized / connected.
8. Select **Diagnosis (All Systems)**.

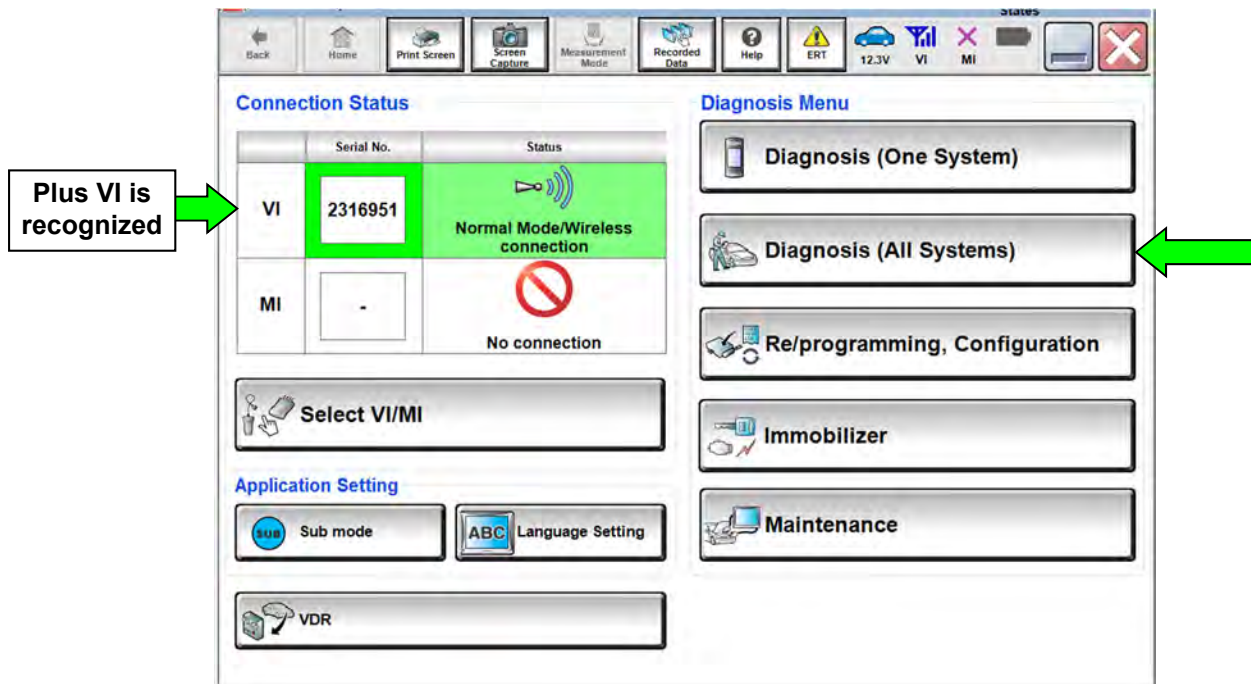

Figure 122

9. Select **Confirm**.

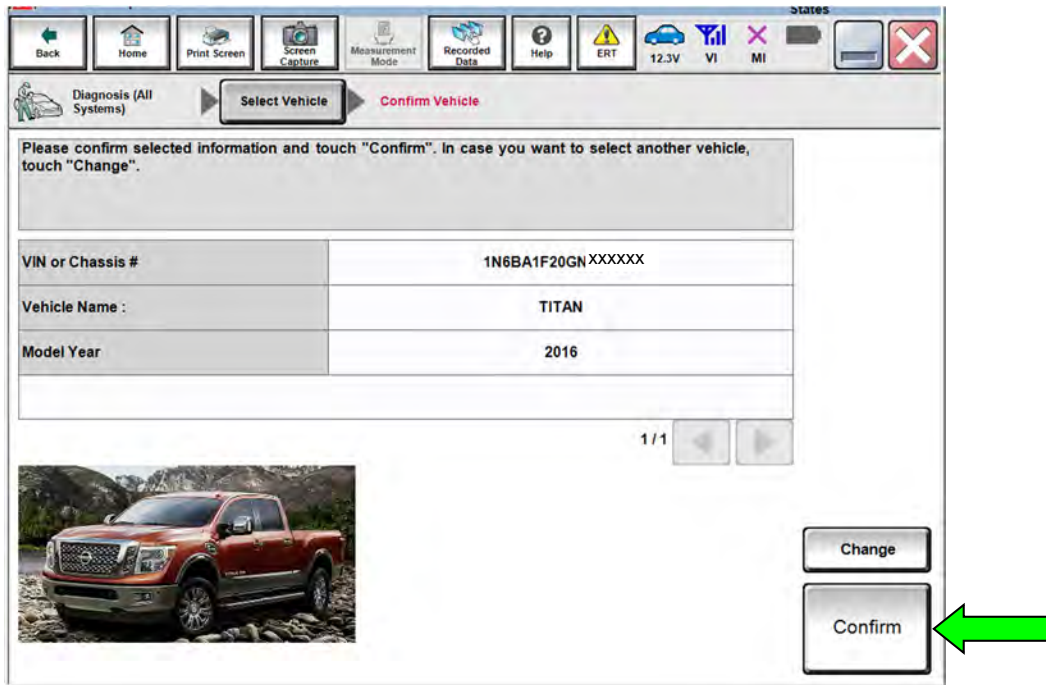

Figure 123

10. If DTC P2560-00 displays, erase the DTC (select **ERASE**).

- If DTC P2560-00 does not display, go to step 11.

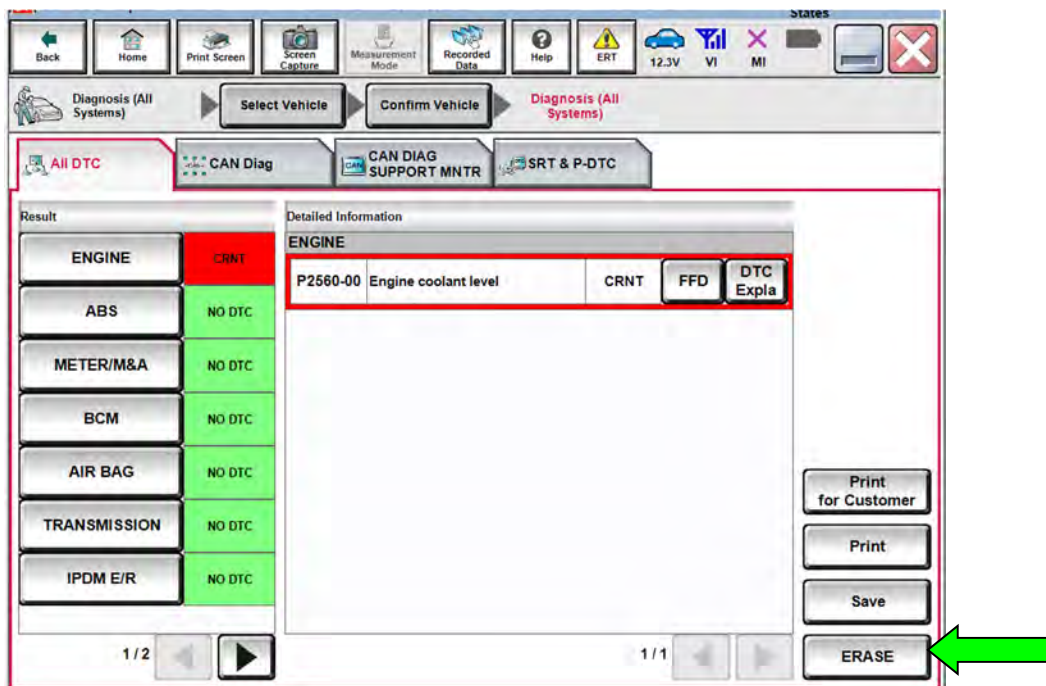

Figure 124

11. Select **ENGINE**.

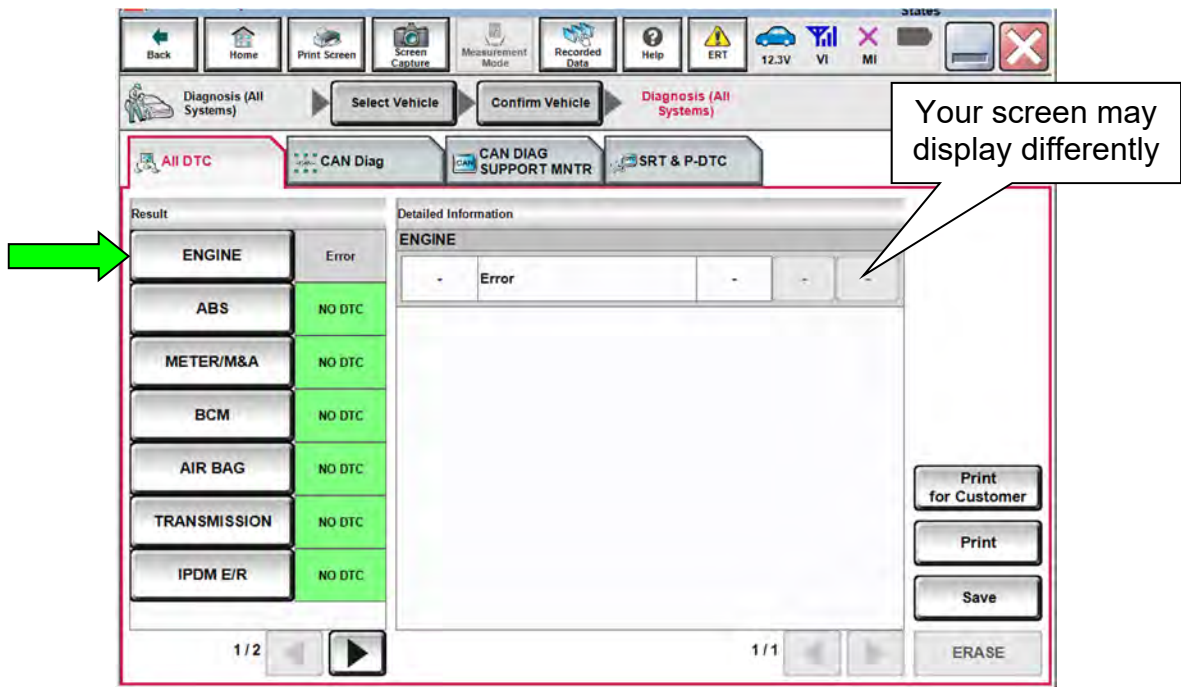

Figure 125

12. Select the following:

- a. **Work Support**
- b. **RTCV actuator calibrate**
- c. **Start**

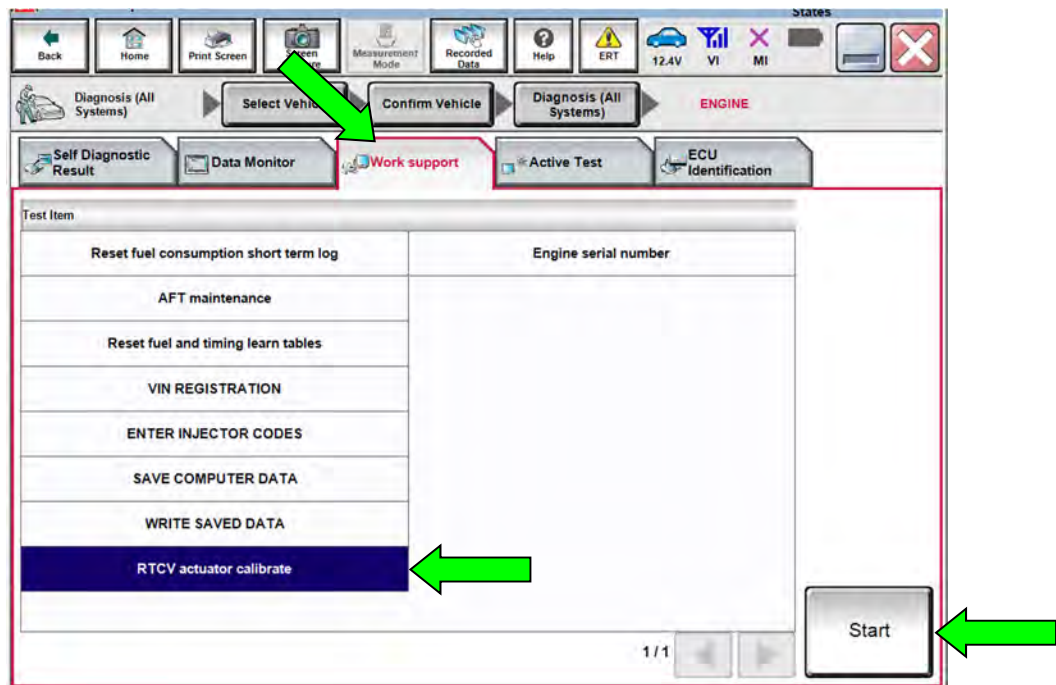

Figure 126

13. Stand near the engine with the hood open.

14. Select **Calibrate**.

- **DO NOT SELECT “Install”**.
- Listen to the rotary turbine control valve actuator (actuator).
 - During the calibration process, the actuator will make a rattling, clicking type noise.
- When the noise stops, calibration is complete.
NOTE: C-III plus does not give a confirmation notice. Calibration is complete when actuator noise stops.

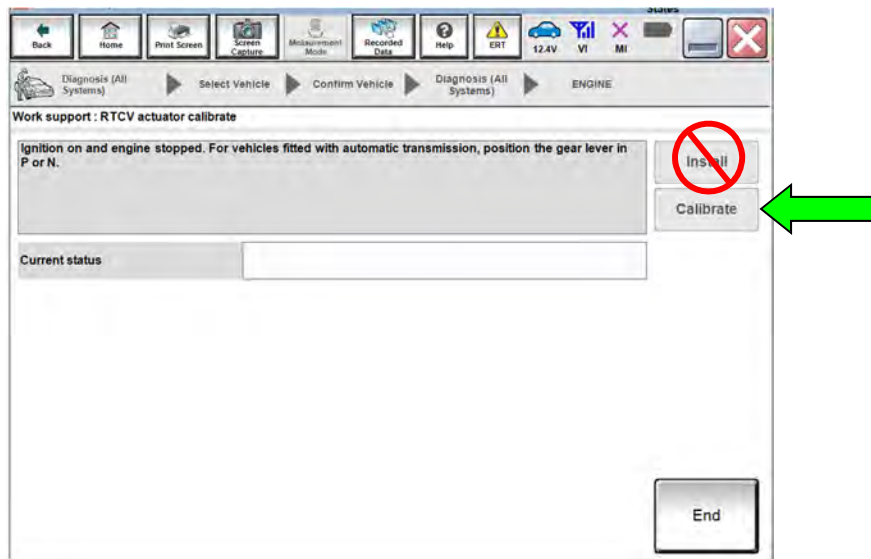

Figure 127

15. Once calibration is complete, select **End**.

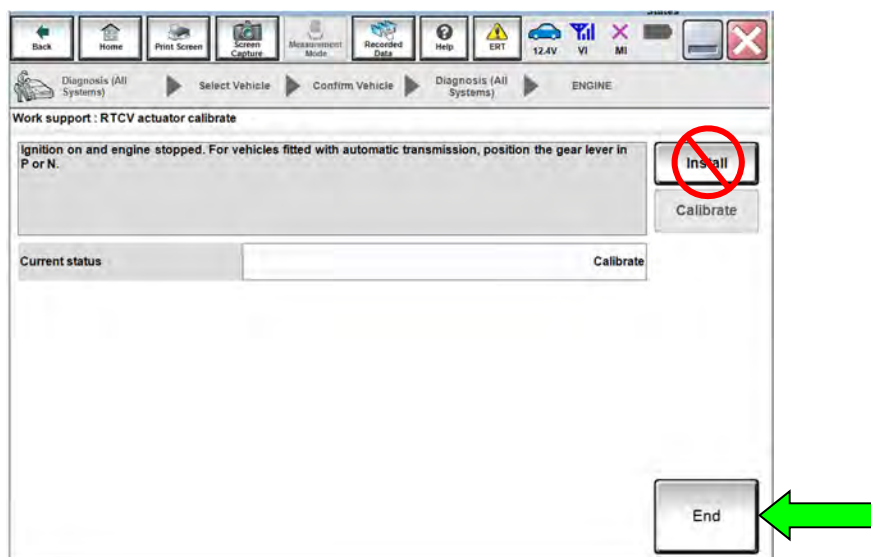

Figure 128

PARTS INFORMATION

Parts needed when replacing the HP turbocharger:

DESCRIPTION	PART NUMBER	QUANTITY
PARTS KIT-ENG (high pressure turbocharger parts kit)	10007-EZ40A	1
P-80 [®] Emulsion	999MP-P80EMUP	1 tube (a) (b)

(a) P-80[®] Emulsion are available through the Nissan Maintenance Advantage program: Phone: 877-NIS-NMA1 (877-647-6621). Website order via link on dealer portal www.NNAnet.com and click on the “Maintenance Advantage” link.

- P-80[®] Emulsion is also available through local sources.

(b) For warranty repairs, P-80[®] Emulsion must be used on all “air handling system” O-ring seals. For customer pay repairs, P-80[®] Emulsion is recommended, but an equivalent water based assembly lubricant may be used.

CAUTION: Do not use petroleum based lubricants as they may cause damage to the “air handling system” O-ring seals.



P-80[®] Emulsion

PARTS INFORMATION (continued)

Parts Cross Reference List (for HP Turbocharger Parts Kit)

NOTE: The following table lists all individual parts in the high pressure turbocharger parts kit, # 10007-EZ40A, plus a crossover reference to Cummins' part numbers.

DESCRIPTION	NISSAN P/N	CUMMINS P/N	QTY
High Pressure Turbocharger	10007-EZ40A	- -	1
SEAL-O RING	21049-EZ40C	5266152	2
GASKET-INTAKE MANIFOLD	14035-EZ40A	4976436	8
BOLT	11035-EZ41D	4325254	8
BOLT	11035-EZ43A	4359786	2
GASKET	14038-EZ40A	4325399	1
EGR TUBE GASKET	14722-EZ40B	4325416	1
SEAL-O RING	16569-EZ40A	2835314	1
BOLT	14069-EZ40C	3796378	2
TURBOCHARGER OUTLET GASKET	14445-EZ40A	3779725	1
BOLT	11035-EZ49C	3785556	3
GASKET-EYE BOLT	15189-EZ41A	3094065	2
TURBOCHARGER OIL OUTLET GASKET	15196-EZ40C	4325860	1
BOLT	11035-EZ40D	4325243	2
SEAL-O RING	16569-EZ40D	3779750	2
BOLT	14069-EZ40D	3796377	3
BOLT	11035-EZ43D	4359860	2
GASKET-EYE BOLT	15189-EZ40A	4894721	2
SEAL-O RING	21049-EZ40B	4977258	2
SEAL-O RING	15066-EZ42C	3029820	1
SEAL OIL LEVEL GAUGE GUIDE	15066-EZ41B	3946188	1
SEAL-O RING	15056-EZ40E	4325402	1
High Pressure Turbocharger Speed Sensor O-ring Seal	22131-EZ40C	3787623	1

CLAIMS INFORMATION

Submit a Primary Part (PP) type line claim using the following claims coding:

DESCRIPTION	PFP	OP CODE	SYM	DIA	FRT
Install High Pressure Turbocharger Assembly	(1)	DX48AA	HD	32	4.6

(1) Reference the Parts Information table on page 54, and use the High Pressure Turbocharger as the Primary Failed Part (PFP).

OR

Submit a Primary Part (PP) type line claim using the following claims coding:

DESCRIPTION	PFP	OP CODE	SYM	DIA	FRT
Perform ECM Reprogram	(1)	DE97AA	HD	32	(2)

(1) Refer to the Electronic Parts Catalog, and use ECM Assembly (23703-*****) as the Primary Failed Part (PFP).

(2) Reference the current Nissan Warranty Flat Rate Manual and use the indicated Flat Rate Time.

AMENDMENT HISTORY

PUBLISHED DATE	REFERENCE	DESCRIPTION
February 25, 2019	NTB19-017	Original bulletin published