



Powering Business Worldwide

COOPER POWER
SERIES

Distribution Transformers

Functional Specification Guide

Three-Phase Pad-mounted Compartmental Type

PS202003EN

Functional Specification for Critical Application, Envirotran HDC Transformers 45 – 10,000 kVA

Note: Any item below labeled as **{Optional}** should be used or removed to ensure spec clarity.

1.0 Scope

- 1.1. This specification covers the electrical and mechanical characteristics of Eaton's Cooper Power series 45-10,000 kVA Three-Phase Step-Down Pad-Mounted Distribution Transformers. KVA ratings for transformers with secondary voltages not exceeding 700V are 45-3,750 kVA, while kVA ratings for transformers with secondary voltages greater than 700 V are 1,000-10,000 kVA. Product is per Catalog Data CA202003EN. The transformers will be applied to critical load, so the design, manufacture, and test of the transformers must yield unwavering quality.

2.0 Applicable Standards

- 2.1. All characteristics, definitions, and terminology, except as specifically covered in this specification, shall be in accordance with the latest revision of the following ANSI[®], IEEE[®], NEMA[®], and Department of Energy standards.

IEEE Std C57.12.00TM-2010 standard – General Requirements for Liquid-Immersed Distribution, Power, and Regulating Transformers.

IEEE Std C57.12.28TM-2014 standard – Pad-Mounted Equipment - Enclosure Integrity.

IEEE Std C57.12.34TM-2009 standard – Requirements for Pad-Mounted, Compartmental-Type, Self-Cooled, Three-Phase Distribution Transformers (2500 kVA and Smaller) - High Voltage: 34500GrdY/19920 Volts and Below; Low-Voltage: 480 Volt 2500 kVA and Smaller (*issued in March 2005 - combines IEEE Std C57.12.22 and IEEE Std C57.12.26 standards*).

IEEE Std C57.12.90TM-2010-standard – Test Code for Liquid-Immersed Distribution, Power, and Regulating Transformers and IEEE Guide for Short-Circuit Testing of Distribution and Power Transformers.

IEEE Std C57.12.91TM-2011 standard – Guide for Loading Mineral-Oil-Immersed Transformers.

NEMA TR 1-1993 (R2000) – Transformers, Regulators and Reactors, Table 0-2 Audible Sound Levels for Liquid-Immersed Power Transformers.

NEMA 260-1996 (2004) – Safety Labels for Pad-Mounted Switchgear and Transformers Sited in Public Areas.

10 CFR Part 431 – Department of Energy – Energy Conservation Program: Energy Conservation Standards for Distribution Transformers; Final Rule.

3.0 Ratings

- 3.1. The transformer shall be designed in accordance with this specification and the kVA rating shall be listed in the data sheet (end of specification). The acceptable range will be 45 thru 10,000 kVA.
- 3.2. The primary voltage and the basic lightning impulse insulation level (BIL) shall be specified on the data sheet (reference Table 1 for common examples). **{Optional}** The basic impulse level (BIL) shall be upgraded to the “Power Transformer” column listed in Table 1. The upgraded insulation is intended to add additional protection against voltage transients and switching surges.

OR

{Optional} The basic impulse level (BIL) shall be higher than that listed in Table 1, and will be stated on the data sheet.

- 3.3. The secondary voltage and the basic impulse insulation level (BIL) shall be in accordance with the secondary voltages listed in Table 1 and shall be specified on the data sheet. **{Optional}** The basic impulse level (BIL) shall be upgraded to the “Power Transformer” column listed in Table 1. The upgraded insulation is intended to add additional protection against voltage transients and switching surges.

OR

{Optional} The basic impulse level (BIL) shall be higher than that listed in Table 1, and will be stated on the data sheet.

Table 1
Transformer Ratings and Electrical
Characteristics

Transformer	Basic Impulse Insulation Level – BIL (kV)	
Voltage Ratings (volts)	Distribution Transformers	Power Transformers
Secondary Voltages	30	45
208Y/120		
480Y/277		
575Y/332		
600Y/347		
690Y/398		
240 Delta		
480 Delta		
240 Delta with 120 Mid-Tap		
480 Delta with 240 Mid-Tap		
Primary Voltages		
2400 Delta	60	60
4160 Delta	60	75
4800 Delta	60	75
7200 Delta	75	95
12000 Delta	95	110
12470 Delta	95	110
13200 Delta	95	110
13800 Delta	95	110
14400 Delta	95	110
16340 Delta	95	110
34500 Delta	150	200
43800 Delta	-	250
4160GrdY/2400	60	75
8320GrdY/4800	75	95
12470GrdY/7200	95	110
13200GrdY/7620	95	110
13800GrdY/7970	95	110
22860GrdY/13200	125	150
23900GrdY/13800	125	150
24940GrdY/14400	125	150
34500GrdY/19920	150	200
43800GrdY/25300	-	250

** Note to Specifier – The above table is not meant to list every voltage available.

- For complete connector rating, see IEEE Std 386™-2006 standard.
- Transformers are suitable for connectors with phase-to-ground or phase-to-ground/phase-to-phase high-voltage ratings as listed.
- Arrester coordination may require higher BIL on multiple connections than indicated to achieve a minimum protection level of 20%.

- 3.4. **{Optional}** The transformer shall have a dual voltage primary to be reconnected with an externally operable, de-energized switch. Voltage provided per data sheet. The voltage provided and the basic lightning impulse insulation level (BIL) shall be in accordance with Table 1.
- 3.5. **{Optional}** The transformer shall be furnished with full capacity high-voltage taps. The tap-changer shall be clearly labeled to reflect that the transformer must be de-energized before operating the tap-changer as required in Section 4.3 of IEEE Std C57.12.34™-2009 standard. The tap configuration shall be listed in the data sheet provided. The tap-changer shall be operable on the higher voltage only for transformers with dual voltage primaries.
- 3.6. The transformer, filled with Envirotemp™ FR3™, shall have a 65 °C average winding temperature rise rating. The above winding temperature rise shall not exceed 65 °C when loaded at base kVA rating.

OR

The transformer, filled with Envirotemp™ FR3™, shall have a 75 °C average winding temperature rise rating. The average winding temperature rise shall not exceed 75 °C when loaded at base kVA rating. *Note: [delete after selection] The higher winding rise utilizes the benefits of Envirotemp™ FR3™ fluid, making for a more cost effective solution.*

- 3.7. The percent impedance voltage, as measured on the rated voltage connection, shall be per Table 2. For target impedances, the tolerance on the impedance shall be +/- 7.5% of nominal value for impedance values greater than 2.5%. The tolerance on the impedance shall be +/- 10.0% for impedance values less than or equal to 2.5%.

Table 2
Percent Impedance Voltage

KVA Rating (Low voltage < 700 V)	Impedance
75	1.10 - 5.75
112.5-300	1.40 - 5.75
500	1.70 - 5.75
750-3750	5.75 nominal

KVA Rating	Low voltage > 700 V (all nominal values)		
	≤150 kV BIL	200 kV BIL	250 kV BIL
1000 - 5000	5.75	7.00	7.50
7500 - 10000	6.50	7.00	7.50

4.0 Construction

- 4.1. The core and coil shall be vacuum processed to ensure maximum penetration of insulating fluid into the coil insulation system. While under vacuum, the windings will be energized to heat the coils and drive out moisture, and the transformer will be filled with preheated filtered degassed insulating fluid. The core shall be manufactured from burr-free, grain-oriented silicon steel and shall be precisely stacked to eliminate gaps in the corner joints. The coil shall be insulated with B-stage, epoxy coated, diamond pattern, insulating paper, which shall be thermally cured under pressure to ensure proper bonding of conductor and paper. Coils shall be either aluminum or copper {eliminate a metal if one is required over the other}.
- 4.2. The dielectric coolant shall be listed less-flammable fluid meeting the requirements of National Electrical Code Section 450-23 and the requirements of the National Electrical Safety Code (IEEE Std C2™-2002 standard), Section 15. The dielectric coolant shall be non-toxic*, non-bioaccumulating and be readily and completely biodegradable per EPA OPPTS 835.3100. The base fluid shall be 100% derived from edible seed oils and food grade performance enhancing additives. The fluid shall not require genetically altered seeds for its base oil. The fluid shall result in zero mortality when tested on trout fry *. The fluid shall be certified to comply with the US EPA Environmental Technology Verification (ETV) requirements, and tested for compatibility with transformer components. The fluid shall be Factory Mutual Approved®, UL® Classified Dielectric Medium (UL-EOUV) and UL® Classified Transformer Fluid (UL-EOVK), Envirotemp™ FR3™ fluid.
*(Per OECD G.L. 203)
- 4.3. Tank and Cabinet Enclosure
 - 4.3.1. The high-voltage and low-voltage compartments, separated by a metal barrier, shall be located side-by-side on one side of the transformer tank. When viewed from the front, the low-voltage compartment shall be on the right. Each compartment shall have a door that is constructed so as to provide access to the high-voltage compartment only after the door to the low-voltage compartment has been opened. There shall be one or more additional fastening devices that must be removed before the high-voltage door can be opened. Where the low-voltage compartment door is of a flat panel design, the compartment door shall have three-point latching with a handle provided for a locking device. Hinge pins and associated barrels shall be constructed of corrosion-resistant material, passivated ANSI® Type 304 or the equivalent.
 - 4.3.2. A recessed, captive, penta-head {or hex-head} bolt that meets the dimensions per IEEE Std C57.12.28™-2014 standard shall secure all access doors.
 - 4.3.3. The compartment depth shall be in accordance with IEEE Std C57.12.34™-2009 standard, unless additional depth is specified.
 - 4.3.4. The tank base must be designed to allow skidding or rolling in any direction. Lifting provisions shall consist of four lifting lugs welded to the tank.

- 4.3.5. The tank shall be constructed to withstand 7 psi without permanent deformation, and 15 psi without rupture. The tank shall include a 15 psig pressure relief valve with a flow rate of minimum 35 SCFM.
- 4.3.6. The exterior of the unit shall be painted Munsell 7GY3.29/1.5 green (STD), {ANSI[®] 70 gray}, or {ANSI[®] 61 gray} in color. If a special paint color is specified on the data sheet, a federal spec number or paint chip will be provided at the time of order. The cabinet interior and front plate shall be painted gray for ease of viewing the inside compartment.
- 4.3.7. The tank shall be complete with an anodized aluminum laser engraved nameplate. This nameplate shall meet Nameplate B per IEEE Std C57.12.00TM-2010 standard.

4.4. High Voltage Bushings and Terminals

- 4.4.1. High voltage bushings will be installed in the high voltage termination compartment located on the front left of the transformer and requiring access via the low voltage termination compartment on the front right.
- 4.4.2. The transformer shall be provided with three (3) {six (6)} sidewall mounted high voltage bushings, either 200 amp wells {or 600 amp dead-break} for deadfront application and arranged for radial {loop} feed configuration.

OR

The transformer shall be provided with three (3) sidewall mounted electrical grade wet process porcelain high voltage bushings rated for full three-phase duty with a two-hole spade {or an eyebolt} connector.

4.5. Low Voltage Bushings and Terminals

4.5.1. Bushing Style

- 4.5.1.1. Voltages less than 700 Volts: The transformer shall be provided with tin-plated spade-type bushings for vertical takeoff. The spacing of the connection holes shall be 1.75" on center, per IEEE Std C57.12.34TM-2009 standard Figure 13a.
- 4.5.1.2. Transformers 300 kVA and below, and 500 kVA with 480Y/277 secondary will have two piece low voltage bushings with studs and screw on spades. Transformers 500 kVA with 208Y/120 secondary and all transformers above 500 kVA will have one-piece bushings.
- 4.5.1.3. Bushing hole quantities shall be provided per Table 3 unless specifically requested on the data sheet.

Table 3
Standard / Maximum Bushing Hole Quantities

kVA Rating	208Y Secondary	480Y Secondary
<300	Four {Up to 16}	Four {Up to 16}
500	Six {Up to 12}	Four {Up to 16}
750 – 1500	Twelve {Up to 20}	Six {Up to 12}
2000 – 3750	N/A	Twelve {Up to 20}

(Re: Catalog Data CA800017EN, CA800023EN, and CA800018EN)

- 4.5.1.4. Bushing supports shall be provided for transformers requiring 10 or more connection holes. Bushing supports shall be affixed to the cabinet sidewalls; tank-mounted supports mountings are not acceptable.
- 4.5.1.5. The transformer shall be provided with bushings in a staggered arrangement in accordance with Figure 11a dimensions (Figure 12a dimensions may be specified when a larger termination compartment for greater working space is desired) of IEEE Std C57.12.34™-2009 standard.
- 4.5.2. Voltages greater than 700 Volts: The transformer shall be provided with three (3) {six (6)} sidewall mounted high voltage bushings, either 200 amp wells {or 600 amp dead-break} for deadfront application and arranged for radial {loop} feed configuration.

OR

The transformer shall be provided with three (3) sidewall mounted electrical grade wet process porcelain high voltage bushings rated for full three-phase duty with a two-hole spade {or an eyebolt} connector. Provide additional front barrier for high voltage live front secondary, creating an additional barrier after the low voltage door has been opened.

- 4.6. The primary switching scheme provided with the transformer shall be one (*note: only available option for radial feed*), two, or three on-off under-oil load-break switch(s), or one four-position V or T-blade load-break sectionalizing switch. Refer to Appendix 1 for the schematics of these switching options (Re: Catalog Data CA800005EN and CA800019EN). The primary disconnect option shall be stated on the data sheet.
- 4.6.1. Make-before-break option for four-position, sectionalizing switch is available on the data sheet. This switch option provides improved system reliability by eliminating momentary interruptions during switching operations.
- 4.7. **{Optional}** The overcurrent protection scheme provided with the transformer shall be listed on the data sheet. Below is a list of definitions. If for any reason a special protection scheme is required it shall be clearly stated on the inquiry.
- Bay-O-Net in series with ELSP current-limiting fuses

- Available up to 130 amps of full-load transformer current, up to 34.5 kV grounded wye, or 23 kV delta). The high-voltage overcurrent protection scheme provided with the transformer shall be an externally removable loadbreak expulsion Bay-O-Net fuse assembly with a flapper valve to minimize oil spillage. The bayonet fuses shall be in series with ELSP under-oil partial-range current-limiting back-up fuses with an interrupting rating of 50,000 A. (Re: Catalog Data CA132015EN, CA132009EN, CA132010EN, CA132012EN, CA132011EN, CA132007EN, and CA132013EN)
 - Under-oil Cartridge in series with ELSP current-limiting fuses (*Required for voltages 23000Y or Delta and above*)
 - Under-oil cartridge fusing shall be utilized (available up to 208 amps of full-load transformer current, up to 34.5 kV delta). The high-voltage overcurrent protection scheme provided with the transformer shall be under-oil cartridge fusing. Cartridge fuses shall be in series with ELSP under-oil partial-range current-limiting back-up fuses with an interrupting rating of 50,000 A.
 - MagneX Interrupter in series with ELSP current-limiting fuses
 - Available up to 42 amps of full-load transformer current, up to 35 KV grounded wye, or 17.1 KV delta. The high-voltage overcurrent protection scheme provided with the transformer shall be a three-phase trip MagneX Interrupter. This externally resettable device may also be used as an on-off switch. The three-phase MagneX Interrupter shall be in series with ELSP under-oil partial-range current-limiting back-up fuses with an interrupting rating of 50,000 A (Re: Catalog Data CA132017EN and CA132013EN).
 - Integral Vacuum Fault Interrupter (VFI) in series with ELSP current-limiting fuses
 - Available from 13 amps up to 900 amps of full-load transformer current, up to 34.5 kV, grounded wye or delta, maximum 150 KV BIL. The high-voltage or low-voltage overcurrent protection scheme provided with the transformer shall be an integral Vacuum Fault Interrupter (VFI). The VFI shall have a maximum interrupting rating of 12,000A RMS symmetrical (optional 16,000 A RMS symmetrical available at 15 KV) with resettable fault protection up through 35kV. The VFI shall also include a Tri-Phase electronic breaker control with over 100 minimum trip settings and 5 selectable time current curves. The minimum trip setting shall be XX amps, and curve profile shall be the EF, KF, TF, F, or H (Re: Bulletin B210-02039 and Service Information S285-75-1 for the electronic control). VFI shall be in series with ELSP under-oil partial-range current-limiting back-up fuses with an interrupting rating of 50,000 A.
 - Optional VFI Accessories: SCADA board; Ground fault detection; Motor operator assembly; Visible break window.
- 4.8. **{Optional}** The overvoltage protection scheme provided with the transformer shall consist of one of the following attributes as listed in data sheet. If for any reason a special protection scheme is required it shall be clearly stated on the inquiry.

- Primary overvoltage protection shall be provided by externally mounted, Heavy-Duty Distribution-Class MOV arresters.
- Primary overvoltage protection shall be provided by externally mounted, Station-Class MOV surge arresters.
- Primary overvoltage protection shall be provided by Under Oil, Heavy-Duty MOV Distribution-Class arresters.
- Provisions for Arresters.
- Primary overvoltage protection shall consist of elbow type MOVE arresters in conjunction with deadfront bushing wells and inserts.

5.0 Optional features to reduce exposure to arc flash

- 5.1. Additional transformer rating nameplate – In addition to the standard nameplate located on the transformer tank, a second nameplate shall be included. The nameplate shall be mounted external to the termination compartments with an industrial grade double-sided adhesive. Its location shall be identified on the data sheet.
- 5.2. External drain valve with sampler – A 1.0” drain valve with sampling device shall be located outside of the cable compartment on the *[low voltage] [high voltage]* side of the tank. The valve shall be protected by a hinged cover with padlock provisions.
- 5.3. External instrumentation package – All included gauges and instrumentation devices shall be located outside of the cable compartments such that access to them does not require exposure to any live circuits. They shall be located inside a separate NEMA[®] 4 rated enclosure on the *[low voltage] [high voltage]* side of the tank. Devices shall include the following: liquid level gauge, dial-type thermometer, pressure/vacuum gauge, pressure relief valve, ½” fluid sampling valve, *[temperature transducer]*, *[pressure transducer]*, *[winding temperature indicator]*, *[rapid rise relay]*, *[upper fill plug/valve]*.
 - 5.3.1. Alarm contacts *[shall] [shall not]* be included on the liquid level gauge, dial-type thermometer, and pressure/vacuum gauges. Any of the accessories above with contacts shall be wired *[to terminal blocks located within the enclosure] [via liquid-tight flexible conduit to a terminal block in a [NEMA[®] 4] [NEMA[®] 4X] control box located below the instrument box]*.
- 5.4. External load break switch – The high voltage switch handle shall be located on the exterior tank wall on the high voltage side of the transformer. The switch shall be operable without exposure to any live circuits. The handle shall be protected by a hinged cover with padlock provisions.
- 5.5. External visible load break (EVLB) switch – The high voltage switch shall be located on the exterior tank wall on the high voltage side of the transformer and shall include a viewing window that provides visible confirmation of the switch blade position. The switch shall be of a *[2-position, on/off] [3-position, on/off/ground]* configuration and shall be operable without exposure to any live circuits. Hinged covers with padlock provisions shall be provided over the window and over the switch handle. Properly sized current-limiting fuses shall be included in the transformer for additional safety.

Note: The EVLB option is limited to the following ratings:

Line voltage (kV)	Maximum kVA
$\geq 12.0 \leq 34.5$	3000
$\geq 7.2 < 12.0$	2000
$\geq 4.16 < 7.2$	1000

5.5.1. For additional safety and ease of maintenance, the following instrumentation devices shall be located on the front of the external load break switch compartment: liquid level gauge, dial-type thermometer, pressure/vacuum gauge, pressure relief valve and ½" fluid sampling valve. These devices shall be protected by a hinged cover with padlock provisions.

Note: If alarm contacts are required a second set of gauges shall be provided in the low voltage cable compartment with the contacts wired to a terminal block on the metal divider between the compartments.

5.6. Infrared (IR) inspection windows – To monitor connections in the high voltage and low voltage compartments without opening the compartment doors, IR window shall be provided. The window(s) shall be IRISS model VPFR-75 or approved equal. The quantity and location of the window(s) shall be indicated on the data sheets.

6.0 Labeling

6.1. A temporary bar code label shall be attached to the exterior of the transformer in accordance with IEEE Std C57.12.34™-2009 standard.

7.0 Finish Performance Requirements

7.1. The tank coating shall meet all requirements in IEEE Std C57.12.28™-2014 standard including:

- Salt Spray
- Crosshatch adhesion
- Humidity
- Impact
- Oil resistance
- Ultraviolet accelerated weathering
- Abrasion resistance – taber abraser

7.2. The enclosure integrity of the tank and cabinet shall meet the requirements for tamper resistance set forth in IEEE Std C57.12.28™-2014 standard including but not limited to the pry test, pull test, and wire probe test.

8.0 Production Testing

8.1. All units shall be tested for the following:

- No-Load (85 °C {or 20 °C}) losses at rated current
 - Total (85 °C) losses at rated current
 - Percent Impedance (85 °C) at rated current
 - Excitation current (100% voltage) test
 - Winding resistance measurement tests
 - Ratio tests using all tap settings
 - Polarity and phase relation tests
 - Induced potential tests
 - Full wave and reduced wave impulse test
- 8.2. In addition, each transformer shall go through the following production leak testing. This is to ensure maximum reliability for this critical application.
- Empty tank – Cap all openings to tank, pressurize with air, and check for weld leaks via soap solution
 - Perform visual inspection of all welds on front plate and tank.
 - Dye penetrate – Apply dye to all welds and check for leaks using special light.
 - 24 hour production leak test – Once cover is applied, pressurize unit to at least 5 psi and hold for 24 hours. Certify that pressure remained unchanged.
- 8.3. One production unit from each design shall undergo heat rise validation as well as sound level testing. Manufacturer shall also provide passing test data for short circuit testing from a similar design.
- 8.4. Transformers shall conform to efficiency levels for liquid immersed distribution transformers, as specified in the Department of Energy ruling “10 CFR Part 431 Energy Conservation Program: Energy Conservation Standards for Distribution Transformers; Final Rule; April 18, 2013.” Manufacturer shall comply with the intent of all regulations set forth in noted ruling.
- 8.5. In addition, the manufacturer shall provide certification upon request for all design and other tests listed in IEEE Std C57.12.00™-2010 standard, including verification that the design has passed short circuit criteria per IEEE Std C57.12.00™-2010 and IEEE Std C57.12.90™-2010 standards.
- 8.6. If specified on data sheet, the proposal bid shall be evaluated with guaranteed losses due to a loss evaluation, manufacturer shall conform to guaranteed average losses as specified in IEEE Std C57.12.00™-2010 standard. The no-load losses of a transformer shall not exceed the specified no-load losses by more than 10%, and the total losses of a transformer shall not exceed the specified total losses by more than 6%.

9.0 Approved Manufacturers

- 9.1. Eaton—Waukesha WI

10.0 Accessories

10.1. The following standard accessories and options shall be provided:

- 1.0" Upper Fill Plug with Filter Press Connection
- 1.0" Drain/Sampling Valve
- Bolted Cover
- Lifting Lugs (4)
- Liquid Level Gauge
- Dial Type Thermometer
- Pressure/Vacuum Gauge

10.2. The following accessories may be required (as specified in data sheet):

- Welded main tank cover with bolted handhole (standard above 1500 kVA)
- 1.0" drain valve w/ sampling in LV compartment (standard 750 kVA & above)
- 24", 30", or 36" cabinet depth
- Upper fill valve
- Spare bayonet fuse links
- Fault indicator provisions
- Ground connectors
- Mr. Ouch warning & danger signs
- Danger high voltage warning signs
- Miscellaneous stenciling
- Non-PCB decal
- Touch-up paint
- Interphase barriers (for live front primary units only)
- Seismic zone 3 and 4 tank anchoring
- Complete 304L stainless steel tank and cabinet
- 409 {304L} stainless steel tank base and cabinet sides & sill (partial)
- Liquid level gauge with auxiliary contacts
- Dial-type thermometer gauge with auxiliary contacts
- Pressure vacuum gauge with auxiliary contacts
- Current or potential transformers
- Rapid rise relay with seal-in panel
- Winding temperature indicator
- Watt-hour meter package – includes GE[®] kV2c Encompass[™] Electronic Meter. Factory supplied wiring shall be internal to the cabinet, not in conduit. Communication connection shall be the OPTOCOM port.
- Harmonic resistant K-factor design, K=4, 9, 13, or 20
- Forced air KNAF rating. (*Note: Forced air rating no longer provides tamper resistance, excluding certain compliance with ANSI[®] standards*)
- Future forced air rating
- FM Global[®] (FM) Approved transformer (to comply with NEC 450-23 listing restrictions for installations on, near, or inside of buildings)
- Combination UL Listed & Classified[®] transformer (to comply with NEC 450-23 listing restrictions for installations on, near, or inside of buildings) per UL XPLH

- UL Listed® transformer (certifying compliance with ANSI® standards only) per UL® XPLH

11.0 Shipping

- 11.1. Transformers, 1000 kVA and below, shall be palletized. Transformers, 1500 kVA and larger, shall be loaded and unloaded with overhead cranes, so a pallet is not to be provided for these transformers.

12.0 Data With Proposal

- 12.1. The following data shall be submitted with the proposal:

- Core losses (when requested per Sections 7.6).
- Winding losses (when requested per Sections 7.6).
- Percent Impedance
- Typical bid drawing
- Approval drawing – drawings shall show final dimensions and features. When requested, approval drawings shall be provided per quoted leadtime.
- Record Drawing – drawings shall show final dimensions and features. When requested, record drawings shall be provided.

13.0 Service

- 13.1. The manufacturer of the transformer shall have regional service centers located within 2 hours flight time of all contiguous 48 states. Service personnel shall be factory trained in commissioning and routine service of quoted transformers.

APPENDIX 1: Switching Options and Schematics

1 On/Off Switch

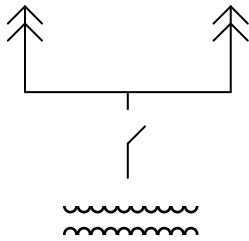

2 On/Off Switches

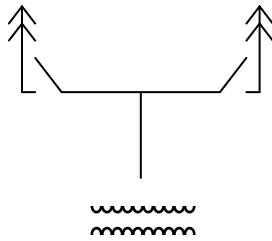

3 On/Off Switches

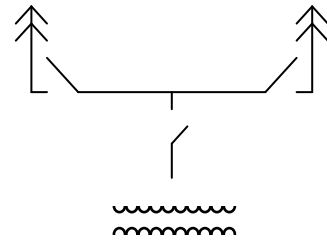

(Re: Catalog Data CA800019EN)

4-position sectionalizing switches:

V-blade switch

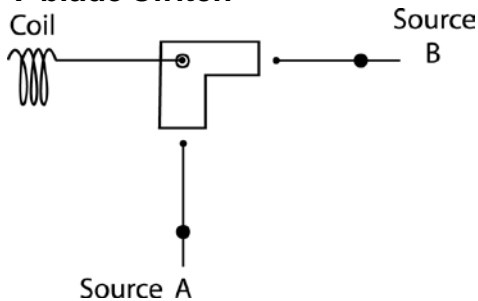

Description of positions:

Feed from A & B

Feed from A only

Feed from B only

Open — the loop is **open** and the transformer is de-energized

T-blade switch

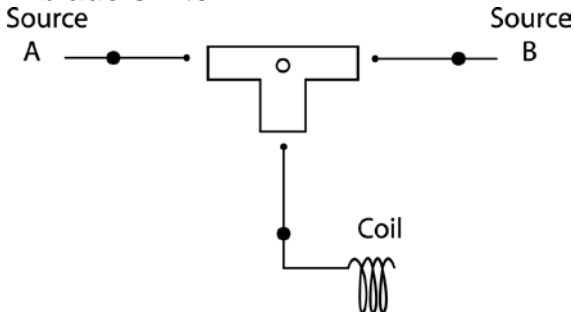

Description of positions:

Feed from A & B

Feed from A only

Feed from B only

Open — the loop is **closed** and the transformer is de-energized

(Re: Catalog Data CA800005EN)