



Catalyst 4948E and Catalyst 4948E-F Switch Installation Guide

January 2011

Americas Headquarters

Cisco Systems, Inc.
170 West Tasman Drive
San Jose, CA 95134-1706
USA
<http://www.cisco.com>
Tel: 408 526-4000
800 553-NETS (6387)
Fax: 408 527-0883

Text Part Number: OL-21561-02

THE SPECIFICATIONS AND INFORMATION REGARDING THE PRODUCTS IN THIS MANUAL ARE SUBJECT TO CHANGE WITHOUT NOTICE. ALL STATEMENTS, INFORMATION, AND RECOMMENDATIONS IN THIS MANUAL ARE BELIEVED TO BE ACCURATE BUT ARE PRESENTED WITHOUT WARRANTY OF ANY KIND, EXPRESS OR IMPLIED. USERS MUST TAKE FULL RESPONSIBILITY FOR THEIR APPLICATION OF ANY PRODUCTS.

THE SOFTWARE LICENSE AND LIMITED WARRANTY FOR THE ACCOMPANYING PRODUCT ARE SET FORTH IN THE INFORMATION PACKET THAT SHIPPED WITH THE PRODUCT AND ARE INCORPORATED HEREIN BY THIS REFERENCE. IF YOU ARE UNABLE TO LOCATE THE SOFTWARE LICENSE OR LIMITED WARRANTY, CONTACT YOUR CISCO REPRESENTATIVE FOR A COPY.

The following information is for FCC compliance of Class A devices: This equipment has been tested and found to comply with the limits for a Class A digital device, pursuant to part 15 of the FCC rules. These limits are designed to provide reasonable protection against harmful interference when the equipment is operated in a commercial environment. This equipment generates, uses, and can radiate radio-frequency energy and, if not installed and used in accordance with the instruction manual, may cause harmful interference to radio communications. Operation of this equipment in a residential area is likely to cause harmful interference, in which case users will be required to correct the interference at their own expense.

The following information is for FCC compliance of Class B devices: The equipment described in this manual generates and may radiate radio-frequency energy. If it is not installed in accordance with Cisco's installation instructions, it may cause interference with radio and television reception. This equipment has been tested and found to comply with the limits for a Class B digital device in accordance with the specifications in part 15 of the FCC rules. These specifications are designed to provide reasonable protection against such interference in a residential installation. However, there is no guarantee that interference will not occur in a particular installation.

Modifying the equipment without Cisco's written authorization may result in the equipment no longer complying with FCC requirements for Class A or Class B digital devices. In that event, your right to use the equipment may be limited by FCC regulations, and you may be required to correct any interference to radio or television communications at your own expense.

You can determine whether your equipment is causing interference by turning it off. If the interference stops, it was probably caused by the Cisco equipment or one of its peripheral devices. If the equipment causes interference to radio or television reception, try to correct the interference by using one or more of the following measures:

- Turn the television or radio antenna until the interference stops.
- Move the equipment to one side or the other of the television or radio.
- Move the equipment farther away from the television or radio.
- Plug the equipment into an outlet that is on a different circuit from the television or radio. (That is, make certain the equipment and the television or radio are on circuits controlled by different circuit breakers or fuses.)

Modifications to this product not authorized by Cisco Systems, Inc. could void the FCC approval and negate your authority to operate the product.

The Cisco implementation of TCP header compression is an adaptation of a program developed by the University of California, Berkeley (UCB) as part of UCB's public domain version of the UNIX operating system. All rights reserved. Copyright © 1981, Regents of the University of California.

NOTWITHSTANDING ANY OTHER WARRANTY HEREIN, ALL DOCUMENT FILES AND SOFTWARE OF THESE SUPPLIERS ARE PROVIDED "AS IS" WITH ALL FAULTS. CISCO AND THE ABOVE-NAMED SUPPLIERS DISCLAIM ALL WARRANTIES, EXPRESSED OR IMPLIED, INCLUDING, WITHOUT LIMITATION, THOSE OF MERCHANTABILITY, FITNESS FOR A PARTICULAR PURPOSE AND NONINFRINGEMENT OR ARISING FROM A COURSE OF DEALING, USAGE, OR TRADE PRACTICE.

IN NO EVENT SHALL CISCO OR ITS SUPPLIERS BE LIABLE FOR ANY INDIRECT, SPECIAL, CONSEQUENTIAL, OR INCIDENTAL DAMAGES, INCLUDING, WITHOUT LIMITATION, LOST PROFITS OR LOSS OR DAMAGE TO DATA ARISING OUT OF THE USE OR INABILITY TO USE THIS MANUAL, EVEN IF CISCO OR ITS SUPPLIERS HAVE BEEN ADVISED OF THE POSSIBILITY OF SUCH DAMAGES.

Cisco and the Cisco Logo are trademarks of Cisco Systems, Inc. and/or its affiliates in the U.S. and other countries. A listing of Cisco's trademarks can be found at www.cisco.com/go/trademarks. Third party trademarks mentioned are the property of their respective owners. The use of the word partner does not imply a partnership relationship between Cisco and any other company. (1005R)

Catalyst 4948E and Catalyst 4948E-F Switch Installation Guide
© 2010–2011 Cisco Systems, Inc. All rights reserved.



CONTENTS

Preface ix

- Audience **i-ix**
- Organization **i-ix**
- Related Documentation **i-x**
- Command Syntax Conventions **i-x**
 - Statement 1071—Warning Definition **i-xi**
- Obtaining Documentation and Submitting a Service Request **i-xvi**

CHAPTER 1

Product Overview 1-1

- Features **1-3**
- Physical and Environmental Specifications **1-7**
- Fan Tray **1-8**
 - Catalyst 4948E Fan Tray (WS-X4993=) **1-8**
 - Catalyst 4948E-F Fan Tray (WS-X4993-F=) **1-9**
- Front Panel LEDs **1-11**

CHAPTER 2

Preparing for Installation 2-1

- Safety **2-1**
- Site Requirements **2-2**
 - Rack-Mounting Guidelines **2-2**
 - Temperature **2-3**
 - Air Flow **2-4**
 - Humidity **2-5**
 - Altitude **2-5**
 - Dust and Particulates **2-5**
 - Corrosion **2-6**
 - Electromagnetic and Radio Frequency Interference **2-6**
 - Shock and Vibration **2-7**
- Power Source Interruptions **2-7**
- System Grounding **2-7**
 - Maintaining Safety with Electricity **2-9**
 - Preventing Electrostatic Discharge Damage **2-10**
- Power Requirements **2-11**

Power Connection Guidelines for AC-Powered Systems 2-12
 Power Connection Guidelines for DC-Powered Systems 2-12
 Cabling Requirements 2-13
 Site Preparation Checklist 2-13

CHAPTER 3

Installing the Switch 3-1

Preparing to Install the Chassis 3-1
 Warnings 3-2
 Verifying Package Contents 3-4
 Required Tools 3-4
 Lifting the Chassis Safely 3-5
 Rack-Mounting the Chassis 3-5
 Attaching the Rack-Mount Brackets to the Chassis 3-6
 Installing the Chassis in the Rack 3-7
 Installing the Cable Guide (Optional) 3-8
 Installing the Catalyst 4948E-F Switch Chassis with the Optional Panduit Air Duct Kit 3-9
 Installing the System Ground 3-10
 Connecting Power to the Switch 3-12
 Connecting AC Source Power to the Switch 3-12
 Connecting DC Source Power to the Switch 3-13
 Attaching the Interface Cables 3-15
 Connecting to the Downlink Ports 3-16
 Installing Uplink Port Transceivers and Cables 3-16
 Connecting to the Ethernet Management Port 3-20
 Connecting to the Console Port 3-20
 Powering Up the Switch 3-21
 Starting the Terminal-Emulation Software 3-21
 Powering Up the Switch 3-21

CHAPTER 4

Removal and Replacement Procedures 4-1

Removing and Installing the DC-Input Power Supply 4-2
 Required Tools 4-2
 Removing the DC-Input Power Supply 4-2
 Installing the DC-Input Power Supply 4-5
 Removing and Installing the AC-Input Power Supply 4-8
 Required Tools 4-8
 Removing the AC-Input Power Supply 4-8
 Installing the AC-Input Power Supply 4-9

Removing and Installing the Fan Tray	4-10
Required Tools	4-10
Removing the Fan Tray	4-10
Installing the Fan Tray	4-11

APPENDIX A**Power Supply Specifications** A-1

300 W AC-Input Power Supply (PWR-C49E-300AC-R)	A-1
300 W AC-Input Power Supply (PWR-C49E-300AC-F)	A-5
300 W AC-Input Power Supply Power Cords	A-8
300 W DC-Input Power Supply (PWR-C49-300DC)	A-12

APPENDIX B**Transceiver, Chassis Connectors, and Cable and Adapter Specifications** B-1

Transceiver Support for Uplink Ports	B-1
1-GB SFP Transceivers	B-1
CWDM SFP Transceivers	B-5
DWDM SFP Transceivers	B-7
10-GB SFP+ Transceivers	B-9
Console Port	B-11
Ethernet Management Port	B-12
Cables and Adapters	B-12
Rollover Cable	B-12
Rollover Cable RJ-45 to DB-9 Adapter (For Connecting to a PC)	B-13

APPENDIX C**Troubleshooting the Installation** C-1

Getting Started	C-2
Problem Solving to the System Component Level	C-2
Identifying Startup Problems	C-2
LED Readings	C-3
Troubleshooting the Power Supply	C-4
Contacting Customer Service	C-4

APPENDIX D**Regulatory Compliance and Safety Information** D-1

Translated Safety Warnings	D-2
Statement 17—Overtemperature Warning	D-2
Statement 37—Restricted Area Warning	D-3
Statement 39—Grounded Equipment Warning	D-4
Statement 43—Jewelry Removal Warning	D-5
Statement 48—Stacking the Chassis Warning	D-8

Statement 171—Ethernet Cable Shielding in Offices	D-9
Statement 258—Fan Tray Removal Warning	D-10
Statement 322—DC Power Off Warning	D-11
Statement 1001—Work During Lightning Activity	D-12
Statement 1003—DC Power Disconnection	D-13
Statement 1004—Installation Instructions	D-15
Statement 1006—Chassis Warning for Rack-Mounting and Servicing	D-16
Statement 1008—Class 1 Laser Product	D-22
Statement 1017—Restricted Area	D-23
Statement 1019—Main Disconnecting Device	D-25
Statement 1030—Equipment Installation	D-26
Statement 1040—Product Disposal	D-28
Statement 1045—Short-circuit Protection	D-30
Statement 1046—Installing or Replacing the Unit	D-32
Statement 1051—Laser Radiation	D-33
Statement 1072—Shock Hazard from Interconnections	D-35
Statement 1074—Comply with Local and National Electrical Codes	D-37
Statement 1075—Hazardous Voltage or Energy Present on DC Power Terminals	D-39
Regulatory Standards Compliance	D-40
GR-1089-CORE Issue 3 Documentation Statements	D-42
Statement 7016—GR-1089-Core Intrabuilding Lightning—Immunity Requirements	D-42
GR-1089-CORE Issue 4 Documentation Statements	D-42
Statement 7001—ESD Mitigation	D-42
Statement 7005—Intra-building Lightning Surge and AC Power Fault	D-42
Statement 7012—Equipment Interfacing with AC Power Ports	D-42
Statement 7013—Equipment Bonding Networks	D-42
Statement 7014—Installation Location	D-42
Statement 7015—Equipment Bonding and Grounding	D-43
Statement 7016—Battery Return Conductor	D-43
Statement 7017—Minimum Steady State DC Input Voltage	D-43
European Directives	D-43
Statement 2002—Declaration of Conformity with Regard to the Directives 2006/95/EC and 2004/108/EC	D-43
Statement 6005—California Perchlorate Contamination Prevention Act (Title 22, California Code of Regulations, Chapter 33)	D-43
EMC Class A Notices and Warnings	D-44
Statement 2017—Class A Notice for FCC	D-44
Statement 2021—Class A Notice for Canada	D-44
Statement 191—VCCI Class A Warning for Japan	D-44

Statement 256—Class A Warning for Hungary	D-45
Statement 257—Class A Notice for Taiwan and Other Traditional Chinese Markets	D-45
Statement 294—Class A Warning for Korea	D-45
Statement 340—Class A Warning for CISPR22	D-46
Statement 371—Power Cable and AC Adapter	D-47

INDEX



Preface

This preface describes the audience, organization, and conventions of the *Catalyst 4948E and Catalyst 4948E-F Switch Installation Guide* and provides information on how to obtain related documentation.

Audience

Only trained and qualified service personnel (as defined in IEC60950-1 and AZ/NZS 60950-1) should install, replace, or service the equipment.

Organization

This guide is organized as follows:

Chapter	Title	Description
Chapter 1	Product Overview	Describes the hardware features, specifications, and functionality of the Catalyst 4948E and Catalyst 4948E-F switches.
Chapter 2	Preparing for Installation	Describes how to prepare your site for the installation of the Catalyst 4948E and Catalyst 4948E-F switches.
Chapter 3	Installing the Switch	Describes how to rack-mount the Catalyst 4948E and the Catalyst 4948E-F switches and attach the cables.
Chapter 4	Removal and Replacement Procedures	Describes how to remove and install the field replaceable units on the Catalyst 4948E and Catalyst 4948E-F switches.
Appendix A	Power Supply Specifications	Lists the switch system specifications.
Appendix B	Transceiver, Chassis Connectors, and Cable and Adapter Specifications	Describes the SFP and SFP+ transceivers, the chassis connectors, and the cables and adapters supplied with the Catalyst 4948E and Catalyst 4948E-F switches.

Chapter	Title	Description
Appendix C	Troubleshooting the Installation	Provides some basic troubleshooting techniques for the Catalyst 4948E and Catalyst 4948E-F switches.
Appendix D	Regulatory Compliance and Safety Information	States compliance information for the Catalyst 4948E and Catalyst 4948E-F switches and provides multiple language translations for the warnings in this guide.

Related Documentation

The Catalyst 4900 series switches use software that also runs on the Catalyst 4500 series switches. Refer to the version of these documents appropriate for your software release:

- *Catalyst 4500 Series Switch Cisco IOS Software Configuration Guide*
http://www.cisco.com/en/US/products/hw/switches/ps4324/products_installation_and_configuration_guides_list.html
- *Catalyst 4500 Series Switch Cisco IOS Command Reference*
http://www.cisco.com/en/US/products/hw/switches/ps4324/prod_command_reference_list.html
- *Catalyst 4500 Series Switch Cisco IOS System Message Guide*
http://www.cisco.com/en/US/products/hw/switches/ps4324/products_system_message_guides_list.html

A specific release note for the Catalyst 4900 switches is available at:

http://www.cisco.com/en/US/docs/switches/lan/catalyst4500/release/note/OL_9592.html

Command Syntax Conventions

Table 1 describes the syntax used with the commands in this document.

Table 1 **Command Syntax Guide**

Convention	Description
boldface	Commands and keywords.
<i>italic</i>	Command input that is supplied by you.
[]	Keywords or arguments that appear within square brackets are optional.
{ x x x }	A choice of keywords (represented by x) appears in braces separated by vertical bars. You must select one.
^ or Ctrl	Represent the key labeled Control. For example, when you read ^D or Ctrl-D, you should hold down the Control key while you press the D key.
screen font	Terminal sessions and information the system displays are in screen font.
boldface screen font	Information you must enter is in boldface screen font .

Table 1 Command Syntax Guide

Convention	Description
< >	Nonprinting characters, such as passwords, appear in angled brackets.
[]	Default responses to system prompts appear in square brackets.

**Note**

Means *reader take note*.

**Tip**

Means *the following information will help you solve a problem*.

**Caution**

Means *reader be careful*. In this situation, you might perform an action that could result in equipment damage or loss of data.

**Warning**

Means *reader be warned*. In this situation, you might perform an action that could result in bodily injury.

Statement 1071—Warning Definition

**Warning**

IMPORTANT SAFETY INSTRUCTIONS

This warning symbol means danger. You are in a situation that could cause bodily injury. Before you work on any equipment, be aware of the hazards involved with electrical circuitry and be familiar with standard practices for preventing accidents. Use the statement number provided at the end of each warning to locate its translation in the translated safety warnings that accompanied this device.

SAVE THESE INSTRUCTIONS

Waarschuwing

BELANGRIJKE VEILIGHEIDSINSTRUCTIES

Dit waarschuwingssymbool betekent gevaar. U verkeert in een situatie die lichamelijk letsel kan veroorzaken. Voordat u aan enige apparatuur gaat werken, dient u zich bewust te zijn van de bij elektrische schakelingen betrokken risico's en dient u op de hoogte te zijn van de standaard praktijken om ongelukken te voorkomen. Gebruik het nummer van de verklaring onderaan de waarschuwing als u een vertaling van de waarschuwing die bij het apparaat wordt geleverd, wilt raadplegen.

BEWAAR DEZE INSTRUCTIES

Varoitus TÄRKEITÄ TURVALLISUUSOHJEITA

Tämä varoitusmerkki merkitsee vaaraa. Tilanne voi aiheuttaa ruumiillisia vammoja. Ennen kuin käsittelet laitteistoa, huomioi sähköpiirien käsittelemiseen liittyvät riskit ja tutustu onnettomuuksien yleisiin ehkäisytapoihin. Turvallisuusvaroitusten käännökset löytyvät laitteen mukana toimitettujen käännettyjen turvallisuusvaroitusten joukosta varoitusten lopussa näkyvien lausuntonumeroiden avulla.

SÄILYTÄ NÄMÄ OHJEET**Attention IMPORTANTES INFORMATIONS DE SÉCURITÉ**

Ce symbole d'avertissement indique un danger. Vous vous trouvez dans une situation pouvant entraîner des blessures ou des dommages corporels. Avant de travailler sur un équipement, soyez conscient des dangers liés aux circuits électriques et familiarisez-vous avec les procédures couramment utilisées pour éviter les accidents. Pour prendre connaissance des traductions des avertissements figurant dans les consignes de sécurité traduites qui accompagnent cet appareil, référez-vous au numéro de l'instruction situé à la fin de chaque avertissement.

CONSERVEZ CES INFORMATIONS**Warnung WICHTIGE SICHERHEITSHINWEISE**

Dieses Warnsymbol bedeutet Gefahr. Sie befinden sich in einer Situation, die zu Verletzungen führen kann. Machen Sie sich vor der Arbeit mit Geräten mit den Gefahren elektrischer Schaltungen und den üblichen Verfahren zur Vorbeugung vor Unfällen vertraut. Suchen Sie mit der am Ende jeder Warnung angegebenen Anweisungsnummer nach der jeweiligen Übersetzung in den übersetzten Sicherheitshinweisen, die zusammen mit diesem Gerät ausgeliefert wurden.

BEWAHREN SIE DIESE HINWEISE GUT AUF.**Avvertenza IMPORTANTI ISTRUZIONI SULLA SICUREZZA**

Questo simbolo di avvertenza indica un pericolo. La situazione potrebbe causare infortuni alle persone. Prima di intervenire su qualsiasi apparecchiatura, occorre essere al corrente dei pericoli relativi ai circuiti elettrici e conoscere le procedure standard per la prevenzione di incidenti. Utilizzare il numero di istruzione presente alla fine di ciascuna avvertenza per individuare le traduzioni delle avvertenze riportate in questo documento.

CONSERVARE QUESTE ISTRUZIONI**Advarsel VIKTIGE SIKKERHETSINSTRUKSJONER**

Dette advarselssymbolet betyr fare. Du er i en situasjon som kan føre til skade på person. Før du begynner å arbeide med noe av utstyret, må du være oppmerksom på farene forbundet med elektriske kretser, og kjenne til standardprosedyrer for å forhindre ulykker. Bruk nummeret i slutten av hver advarsel for å finne oversettelsen i de oversatte sikkerhetsadvarslene som fulgte med denne enheten.

TA VARE PÅ DISSE INSTRUKSJONENE

Aviso INSTRUÇÕES IMPORTANTES DE SEGURANÇA

Este símbolo de aviso significa perigo. Você está em uma situação que poderá ser causadora de lesões corporais. Antes de iniciar a utilização de qualquer equipamento, tenha conhecimento dos perigos envolvidos no manuseio de circuitos elétricos e familiarize-se com as práticas habituais de prevenção de acidentes. Utilize o número da instrução fornecido ao final de cada aviso para localizar sua tradução nos avisos de segurança traduzidos que acompanham este dispositivo.

GUARDE ESTAS INSTRUÇÕES**¡Advertencia! INSTRUCCIONES IMPORTANTES DE SEGURIDAD**

Este símbolo de aviso indica peligro. Existe riesgo para su integridad física. Antes de manipular cualquier equipo, considere los riesgos de la corriente eléctrica y familiarícese con los procedimientos estándar de prevención de accidentes. Al final de cada advertencia encontrará el número que le ayudará a encontrar el texto traducido en el apartado de traducciones que acompaña a este dispositivo.

GUARDE ESTAS INSTRUCCIONES**Varning! VIKTIGA SÄKERHETSANVISNINGAR**

Denna varningssignal signalerar fara. Du befinner dig i en situation som kan leda till personskada. Innan du utför arbete på någon utrustning måste du vara medveten om farorna med elkretsar och känna till vanliga förfaranden för att förebygga olyckor. Använd det nummer som finns i slutet av varje varning för att hitta dess översättning i de översatta säkerhetsvarningar som medföljer denna anordning.

SPARA DESSA ANVISNINGAR**Figyelem FONTOS BIZTONSÁGI ELOÍRÁSOK**

Ez a figyelmeztető jel veszélyre utal. Sérülésveszélyt rejte helyzetben van. Mielőtt bármely berendezésen munkát végezte, legyen figyelemmel az elektromos áramkörök okozta kockázatokra, és ismerkedjen meg a szokásos balesetvédelmi eljárásokkal. A kiadványban szereplő figyelmeztetések fordítása a készülékhez mellékelt biztonsági figyelmeztetések között található; a fordítás az egyes figyelmeztetések végén látható szám alapján kereshető meg.

ORIZZE MEG EZEKET AZ UTASÍTÁSOKAT!**Предупреждение ВАЖНЫЕ ИНСТРУКЦИИ ПО СОБЛЮДЕНИЮ ТЕХНИКИ БЕЗОПАСНОСТИ**

Этот символ предупреждения обозначает опасность. То есть имеет место ситуация, в которой следует опасаться телесных повреждений. Перед эксплуатацией оборудования выясните, каким опасностям может подвергаться пользователь при использовании электрических цепей, и ознакомьтесь с правилами техники безопасности для предотвращения возможных несчастных случаев. Воспользуйтесь номером заявления, приведенным в конце каждого предупреждения, чтобы найти его переведенный вариант в переводе предупреждений по безопасности, прилагаемом к данному устройству.

СОХРАНИТЕ ЭТИ ИНСТРУКЦИИ

警告 重要的安全性说明

此警告符号代表危险。您正处于可能受到严重伤害的工作环境中。在您使用设备开始工作之前，必须充分意识到触电的危险，并熟练掌握防止事故发生的标准工作程序。请根据每项警告结尾提供的声明号码来找到此设备的安全性警告说明的翻译文本。

请保存这些安全性说明

警告 安全上の重要な注意事項

「危険」の意味です。人身事故を予防するための注意事項が記述されています。装置の取り扱い作業を行うときは、電気回路の危険性に注意し、一般的な事故防止策に留意してください。警告の各国語版は、各注意事項の番号を基に、装置に付属の「Translated Safety Warnings」を参照してください。

これらの注意事項を保管しておいてください。

주의 重要 안전 지침

이 경고 기호는 위험을 나타냅니다. 작업자가 신체 부상을 일으킬 수 있는 위험한 환경에 있습니다. 장비에 작업을 수행하기 전에 전기 회로와 관련된 위험을 숙지하고 표준 작업 관례를 숙지하여 사고를 방지하십시오. 각 경고의 마지막 부분에 있는 경고문 번호를 참조하여 이 장치와 함께 제공되는 번역된 안전 경고문에서 해당 번역문을 찾으십시오.

이 지시 사항을 보관하십시오.

Aviso INSTRUÇÕES IMPORTANTES DE SEGURANÇA

Este símbolo de aviso significa perigo. Você se encontra em uma situação em que há risco de lesões corporais. Antes de trabalhar com qualquer equipamento, esteja ciente dos riscos que envolvem os circuitos elétricos e familiarize-se com as práticas padrão de prevenção de acidentes. Use o número da declaração fornecido ao final de cada aviso para localizar sua tradução nos avisos de segurança traduzidos que acompanham o dispositivo.

GUARDE ESTAS INSTRUÇÕES**Advarsel** VIGTIGE SIKKERHEDSANVISNINGER

Dette advarselssymbol betyder fare. Du befinder dig i en situation med risiko for legemeskade. Før du begynder arbejde på udstyr, skal du være opmærksom på de involverede risici, der er ved elektriske kredsløb, og du skal sætte dig ind i standardprocedurer til undgåelse af ulykker. Brug erklæringsnummeret efter hver advarsel for at finde oversættelsen i de oversatte advarsler, der fulgte med denne enhed.

GEM DISSE ANVISNINGER**تحذير****إرشادات الأمان الهامة**

يوضح رمز التحذير هذا وجود خطر. وهذا يعني أنك متواجد في مكان قد ينتج عنه التعرض لإصابات. قبل بدء العمل، احذر مخاطر التعرض للصدمات الكهربائية وكن على علم بالإجراءات القياسية للحيلولة دون وقوع أي حوادث. استخدم رقم البيان الموجود في أخطر كل تحذير لتحديد مكان ترجمته داخل تحذيرات الأمان المترجمة التي تأتي مع الجهاز. قم بحفظ هذه الإرشادات

Upozorenje VAŽNE SIGURNOSNE NAPOMENE

Ovaj simbol upozorenja predstavlja opasnost. Nalazite se u situaciji koja može prouzročiti tjelesne ozljede. Prije rada s bilo kojim uređajem, morate razumjeti opasnosti vezane uz električne sklopove, te biti upoznati sa standardnim načinima izbjegavanja nesreća. U prevedenim sigurnosnim upozorenjima, priloženima uz uređaj, možete prema broju koji se nalazi uz pojedino upozorenje pronaći i njegov prijevod.

SAČUVAJTE OVE UPUTE**Upozornění DŮLEŽITÉ BEZPEČNOSTNÍ POKYNY**

Tento upozorňující symbol označuje nebezpečí. Jste v situaci, která by mohla způsobit nebezpečí úrazu. Před prací na jakémkoliv vybavení si uvědomte nebezpečí související s elektrickými obvody a seznamte se se standardními opatřeními pro předcházení úrazům. Podle čísla na konci každého upozornění vyhledejte jeho překlad v přeložených bezpečnostních upozorněních, která jsou přiložena k zařízení.

USCHOVEJTE TYTO POKYNY**Προειδοποίηση ΣΗΜΑΝΤΙΚΕΣ ΟΔΗΓΙΕΣ ΑΣΦΑΛΕΙΑΣ**

Αυτό το προειδοποιητικό σύμβολο σημαίνει κίνδυνο. Βρίσκεστε σε κατάσταση που μπορεί να προκαλέσει τραυματισμό. Πριν εργαστείτε σε οποιοδήποτε εξοπλισμό, να έχετε υπόψη σας τους κινδύνους που σχετίζονται με τα ηλεκτρικά κυκλώματα και να έχετε εξοικειωθεί με τις συνήθειες πρακτικές για την αποφυγή ατυχημάτων. Χρησιμοποιήστε τον αριθμό δήλωσης που παρέχεται στο τέλος κάθε προειδοποίησης, για να εντοπίσετε τη μετάφρασή της στις μεταφρασμένες προειδοποιήσεις ασφαλείας που συνοδεύουν τη συσκευή.

ΦΥΛΑΞΤΕ ΑΥΤΕΣ ΤΙΣ ΟΔΗΓΙΕΣ**אזהרה****הוראות בטיחות חשובות**

סימן אזהרה זה מסמל סכנה. אתה נמצא במצב העלול לגרום לפציעה. לפני שתעבוד עם ציוד כלשהו, עליך להיות מודע לסכנות הכרוכות במעגלים חשמליים ולהכיר את הנהלים המקובלים למניעת תאונות. השתמש במספר ההוראה המסופק בסופה של כל אזהרה כדי לאתר את התרגום באזהרות הבטיחות המתורגמות שמצורפות להתקן.

שמור הוראות אלה**Opomena VAŽNI BEZBEDNOSNI NAPATCTVIJA**

Симболот за предупредување значи опасност. Се наоѓате во ситуација што може да предизвика телесни повреди. Пред да работите со опремата, бидете свесни за ризикот што постои кај електричните кола и треба да ги познавате стандардните постапки за спречување на несреќни случаи. Искористете го бројот на изјавата што се наоѓа на крајот на секое предупредување за да го најдете неговиот период во prevedените безбедносни предупредувања што се испорачани со уредот.

ЧУВАЈТЕ ГИ ОБИЕ НАПАТСТВИЈА

Ostrzeżenie WAŻNE INSTRUKCJE DOTYCZĄCE BEZPIECZEŃSTWA

Ten symbol ostrzeżenia oznacza niebezpieczeństwo. Zachodzi sytuacja, która może powodować obrażenia ciała. Przed przystąpieniem do prac przy urządzeniach należy zapoznać się z zagrożeniami związanymi z układami elektrycznymi oraz ze standardowymi środkami zapobiegania wypadkom. Na końcu każdego ostrzeżenia podano numer, na podstawie którego można odszukać tłumaczenie tego ostrzeżenia w dołączonym do urządzenia dokumencie z tłumaczeniami ostrzeżeń.

NINIEJSZE INSTRUKCJE NALEŻY ZACHOWAĆ**Upozornenie DŮLEŽITÉ BEZPEČNOSTNÉ POKYNY**

Tento varovný symbol označuje nebezpečenstvo. Nachádzate sa v situácii s nebezpečenstvom úrazu. Pred prácou na akomkoľvek vybavení si uvedomte nebezpečenstvo súvisiace s elektrickými obvodmi a oboznámte sa so štandardnými opatreniami na predchádzanie úrazom. Podľa čísla na konci každého upozornenia vyhľadajte jeho preklad v preložených bezpečnostných upozorneniach, ktoré sú priložené k zariadeniu.

USCHOVAJTE SI TENTO NÁVOD**Opozorilo POMEMBNI VARNOSTNI NAPOTKI**

Ta opozorilni simbol pomeni nevarnost. Nahajate se v situaciji, kjer lahko pride do telesnih poškodb. Preden pričnete z delom na napravi, se morate zavedati nevarnosti udara električnega toka, ter tudi poznati preventivne ukrepe za preprečevanje takšnih nevarnosti. Uporabite obrazložitevno številko na koncu posameznega opozorila, da najdete opis nevarnosti v priloženem varnostnem priročniku.

SHRANITE TE NAPOTKE!**警告****重要安全性指示**

此警告符號代表危險，表示可能造成人身傷害。使用任何設備前，請留心電路相關危險，並熟悉避免意外的標準作法。您可以使用每項警告後的聲明編號，查詢本裝置隨附之安全性警告譯文中的翻譯。請妥善保留此指示

Obtaining Documentation and Submitting a Service Request

For information on obtaining documentation, submitting a service request, and gathering additional information, see the monthly *What's New in Cisco Product Documentation*, which also lists all new and revised Cisco technical documentation, at:

<http://www.cisco.com/en/US/docs/general/whatsnew/whatsnew.html>

Subscribe to the *What's New in Cisco Product Documentation* as a Really Simple Syndication (RSS) feed and set content to be delivered directly to your desktop using a reader application. The RSS feeds are a free service and Cisco currently supports RSS version 2.0.



CHAPTER 1

Product Overview

Revised: January 4, 2012

Both the Catalyst 4948E switch and the Catalyst 4948E-F switch are 1-RU, horizontal, fixed-configuration chassis with 48 10/100/1000 downlink ports and 4 1-GB or 10-GB uplink ports. Both switches have one removable fan tray and support redundant power supplies. The primary difference between the two chassis is that the air flow in the Catalyst 4948E goes from the front of the chassis to the rear of the chassis while the air flow in the Catalyst 4948E-F goes from the rear of the chassis to the front of the chassis. [Figure 1-1](#) shows the front view of both chassis with the major features identified and [Figure 1-2](#) shows the rear view of both chassis with the major features identified.



Note

The fan trays and the power supplies are not interchangeable between the Catalyst 4948E and the Catalyst 4948E-F switch chassis.



Tip

For additional information about the Cisco Catalyst 4948E and the Catalyst 4948E-F switches (including configuration examples and troubleshooting information), see the documents listed on this page:

http://www.cisco.com/en/US/products/ps6021/tsd_products_support_series_home.html

Figure 1-1 Catalyst 4948E and Catalyst 4948E-F Switches—Front View of Chassis (Catalyst 4948E Switch Shown)

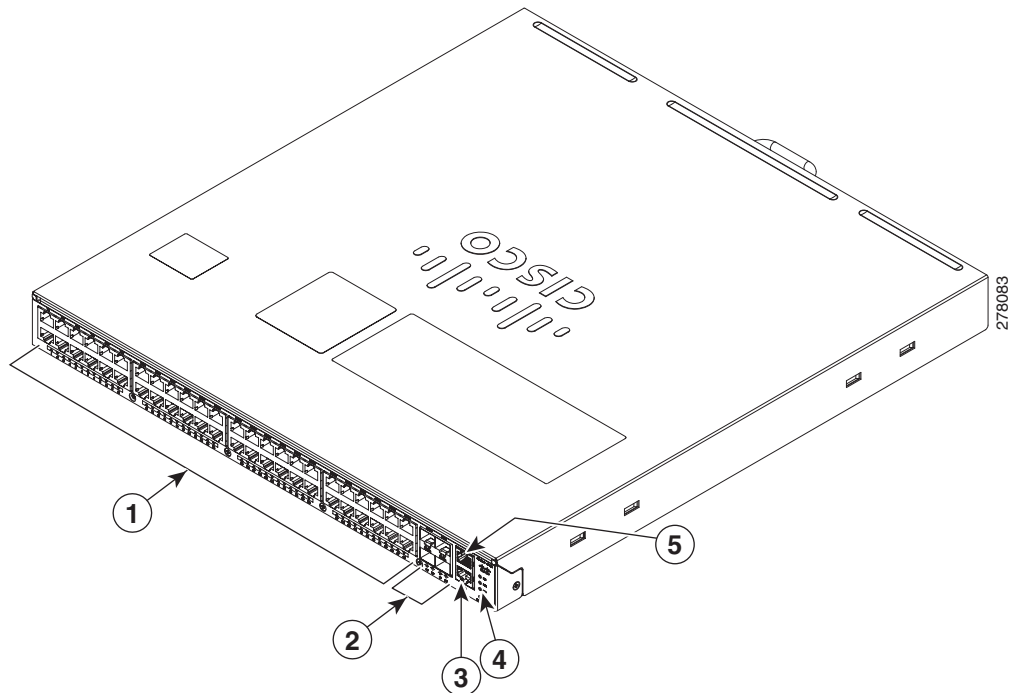

1	48 downlink ports	4	Status LEDs
2	4 uplink ports	5	Console port
3	Management port		



Note

The orientation of the Cisco logo shown in Figure 1-1 identifies the chassis as a Catalyst 4948E switch. The Cisco logo that appears on the Catalyst 4948E-F chassis top cover is rotated 180 degrees. Additional labels are placed on the Catalyst 4948E-F top cover to denote the direction of the airflow through the chassis.

Figure 1-2 Catalyst 4948E and Catalyst 4948E-F Switches—Rear View of Chassis

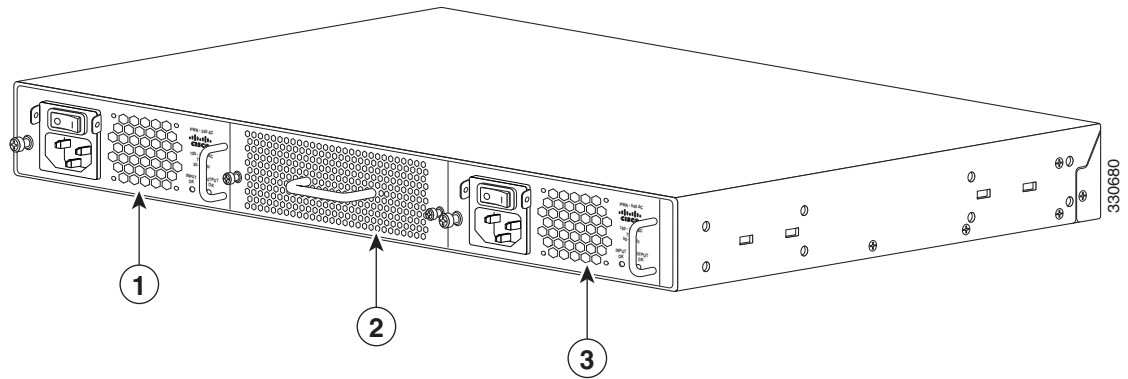

1	Power supply 1 (primary)	3	Power supply 2 (redundant)
2	Fan tray		

This chapter describes the Catalyst 4948E and Catalyst 4948E-F switches and includes these sections:

- [Features, page 1-3](#)
- [Physical and Environmental Specifications, page 1-7](#)
- [Fan Tray, page 1-8](#)
- [Front Panel LEDs, page 1-11](#)

Features

[Table 1-1](#) lists the features of the Catalyst 4948E and the Catalyst 4948E-F switch chassis.

Table 1-1 Catalyst 4948E and Catalyst 4948E-F Switch Features

Feature	Description
Chassis (both chassis)	1-RU, 48 10/100/1000 ports plus 4 1-GB/10-GB ports, fixed configuration switch with redundant power supplies
Uplink ports (both chassis)	<p>The chassis has 4 1-GB or 10-GB uplink ports. An SFP or SFP+ transceiver must be installed in the chassis port socket for the port to operate. Cable type and recommended cabling distance for each port is determined by the type of SFP or SFP+ transceiver installed in the uplink port. A bicolor port link status LED is associated with each uplink port. LED colors indicate the following status:</p> <ul style="list-style-type: none"> • Green—The link is established and operational. • Amber—The port is disabled. • Blinking amber—The system has detected a fault with the link. • Off—No link is established or the transceiver is not installed in the port socket. <p>See Appendix B, “Transceiver, Chassis Connectors, and Cable and Adapter Specifications” for supported SFP and SFP+ transceiver descriptions, specifications, and cabling distances.</p>
Downlink ports (both chassis)	<ul style="list-style-type: none"> • The chassis has 48 10/100/1000BASE autonegotiating-capable downlink ports. Each port has an RJ-45 connector. A bicolor port link status LED is associated with each port. LED colors indicate the following status: • Green—The link is established and operational. • Amber—The port is disabled. • Blinking amber—The system has detected a fault with the link. • Off—No link is established or no network interface cable is installed.
Console port (both chassis)	<p>A console serial port (RJ-45) is provided for switch management using standard console equipment. Additional information including a connector pinout table is provided in Appendix B, “Transceiver, Chassis Connectors, and Cable and Adapter Specifications” for the console port.</p> <p>Note A console cable is not provided in the accessory kit. It can be ordered as an option.</p>
Ethernet management port (both chassis)	<ul style="list-style-type: none"> • The Catalyst 4948E switch provides a 10/100/1000 RJ-45 port Ethernet Management port that can be used to manage the switch through an Ethernet network. This port can also be used to download software to the switch or transfer files to remote servers for analysis or backup storage. • The typical connection to the Management Ethernet port uses an Ethernet cable with RJ-45 connectors at each end. The other end of the cable typically connects to an Ethernet switch, hub, or router that provides connectivity between the multishelf system and networks from which system management is desired. Appendix B, “Transceiver, Chassis Connectors, and Cable and Adapter Specifications” contains additional information for the Ethernet management port including a connector pinout table.

Table 1-1 Catalyst 4948E and Catalyst 4948E-F Switch Features (continued)

Feature	Description
RESET switch (both chassis)	<ul style="list-style-type: none"> Resets and restarts the switch. The switch is recessed on chassis front panel and requires a pointed object to access it.
Fan tray Catalyst 4948E chassis	<ul style="list-style-type: none"> The Catalyst 4948E chassis supports one hot-swappable fan tray (part number WS-X4993=). <p>Note The fan trays are not interchangeable between the Catalyst 4948E and the Catalyst 4948E-F chassis.</p> <ul style="list-style-type: none"> The fan tray has four variable-speed 12 VDC fans. The fan tray installs in the rear of the chassis between the two power supplies. The fan tray for the Catalyst 4948E (WS-X4993=) is color-coded dark grey. A redundant pair of thermal sensors are positioned near the air inlet (front of the chassis) to monitor the ambient air temperature and control the fan tray fan speed. The airflow in the Catalyst 4948E chassis is from front to back. The chassis has a FAN LED (located on the chassis front panel) that provides fan tray status. <ul style="list-style-type: none"> Red—One or more individual fans in the fan tray have failed. Green—All fans in the fan tray are operating normally.
Catalyst 4948E-F chassis	<ul style="list-style-type: none"> The Catalyst 4948E-F chassis supports one hot-swappable fan tray (part number WS-X4993-F=). <p>Note The fan trays are not interchangeable between the Catalyst 4948E and the Catalyst 4948E-F chassis.</p> <ul style="list-style-type: none"> The fan tray has four variable-speed 12 VDC fans. The fan tray installs in the rear of the chassis between the two power supplies. The fan tray for the Catalyst 4948E-F is color-coded blue. A redundant pair of thermal sensors are positioned near the air inlet (rear of the chassis) to monitor the ambient air temperature and control the fan tray fan speed. The airflow in the Catalyst 4948E-F chassis is from back to front. The chassis has a FAN LED (located on the chassis front panel) that provides fan tray status. <ul style="list-style-type: none"> Red—One or more individual fans in the fan tray have failed. Green—All fans in the fan tray are operating normally.

Table 1-1 Catalyst 4948E and Catalyst 4948E-F Switch Features (continued)

Feature	Description
Power supplies Catalyst 4948E	<ul style="list-style-type: none"> • Supports one or two power supplies. The following power supplies are supported: <ul style="list-style-type: none"> – PWR-C49E-300AC-R (300 W AC-input power supply). – PWR-C49-300DC (300 W DC-input power supply). <p>Note The power supplies are not interchangeable between the Catalyst 4948E and the Catalyst 4948E-F switch chassis.</p> <ul style="list-style-type: none"> • The front panels on both of the power supplies for the Catalyst 4948E are color-coded dark grey. <p>Note The 300 W AC-input power supply requires single-phase source AC. Source AC can be out of phase between multiple power supplies because all AC power supply inputs are isolated.</p> <p>Note Appendix A, “Power Supply Specifications” contains additional information on both of the power supplies.</p> <p>Note If the redundant power supply is not installed, the empty power supply bay should be covered using the blank power supply cover (p/n WS-X4994). The blank power supply cover is color-coded dark grey.</p>
Catalyst 4948E-F	<ul style="list-style-type: none"> • Supports one or two power supplies. The following power supplies are supported: <ul style="list-style-type: none"> – PWR-C49E-300AC-F (300 W AC-input power supply, reversed air flow). • The front panel on the power supply for the Catalyst 4948E-F is color-coded blue. <p>Note The 300 W AC-input power supply requires single-phase source AC. Source AC can be out of phase between multiple power supplies because all AC power supply inputs are isolated.</p> <p>Note Appendix A, “Power Supply Specifications” contains additional information on both of the power supplies.</p> <p>Note If the redundant power supply is not installed, the empty power supply bay should be covered using the blank power supply cover (p/n WS-X4994-F). The blank power supply cover is color-coded blue.</p>

Physical and Environmental Specifications

Table 1-2 and Table 1-3 lists the Catalyst 4948E and Catalyst 4948E-F switch chassis environmental and physical specifications.

Table 1-2 Catalyst 4948E and Catalyst 4948E-F Switch Specifications - Environment, Heat Dissipation, Shock and Vibrations, Physical Characteristics, and Airflow

Item	Specification
Environmental	
Temperature, operating	Certified for operation: 32° to 104°F (0° to 40°C) Designed and tested for operation: 32° to 131°F (0° to 55°C)
Temperature, nonoperating and storage	Chassis unpackaged: -4° to 149°F (-20° to 65°C) Chassis in protective shipping package: -40° to 158°F (-40° to 70°C)
Thermal transition	0.5°C per minute (hot to cold) 0.33°C per minute (cold to hot)
Humidity (RH), ambient (noncondensing) operating	Operating: 5% to 90% Nonoperating and storage: 5% to 95%
Altitude, operating	Certified for operation: 0 to 6500 ft (0 to 2000 m) Designed and tested for operation: -200 to 10,000 ft (-60 to 3000 m)
Heat Dissipation	1364 BTU/hour (worst case)
Shock and Vibration	Refer to Appendix D, “Regulatory Compliance and Safety Information” for shock and vibration compliance information for the switch.
Physical Characteristics	
Dimensions (H x W x D)	<ul style="list-style-type: none"> 1.75 x 17.5 x 19.4 in. (4.4 x 44.4 x 49.3 cm). Chassis requires 1 RU. The Catalyst 4948E and the Catalyst 4948E-F switch chassis are designed to install in standard 19-inch equipment racks that meet ANSI/EIA 310-D, IEC 60297, and ETS 300-119 standards.
Weight	<ul style="list-style-type: none"> 14 lb (6.35 kg). Base system; no power supplies and no fan tray. 19 lb (8.62 kg). Fully loaded system; two power supplies and a fan tray.
Airflow	<ul style="list-style-type: none"> 28 CFM (low speed) 44 CFM (high speed)

Table 1-3 Catalyst 4948E and Catalyst 4948E-F Switch Specifications - Acoustic Noise

Acoustic Noise				
Measured per ISO 7779 and declared per ISO 9296				
Bystander positions operating mode at 25°C ambient.				
Sound Pressure, dBA			Sound Power, dBA	
Model	Typical, LpAm	Maximum, LpAD	Typical, LwA	Maximum, LwAD
WS-C4948E	55.6	58.6	62.6	65.6

Fan Tray

Both the Catalyst 4948E and the Catalyst 4948E-F switch chassis have a fan tray that is mounted in the rear of the chassis between the two power supplies. The Catalyst 4948E chassis fan tray (WS-X4993=) provides front-to-back air flow in the chassis and has a front panel that is color-coded dark grey. The Catalyst 4948E-F chassis fan tray (WS-X4993-F=) provides back-to-front air flow and has a front panel that is color-coded blue.

Note

The two fan trays are not interchangeable between the Catalyst 4948E and the Catalyst 4948E-F chassis. The WS-X4993-F fan tray is keyed to prevent insertion in the Catalyst 4948E chassis.

Individual fan speed within the fan trays is controlled by redundant temperature sensors located at the air flow inlet (in the front of the chassis for the Catalyst 4948E and in the rear of the chassis for the Catalyst 4948E-F). There are six programmable temperature thresholds that trigger fan speed change. If there is an individual fan failure, the fan speed on the remaining fans is adjusted to try to compensate for the loss of the fan.

Table 1-4 lists the fan speed settings and the associated temperature thresholds.

Table 1-4 Fan Speeds Versus Chassis Temperature Thresholds

Fan Speed Setting	PWM ¹ Duty Cycle	Chassis Temperature Range Thresholds
Speed 0	41%	T2—89.6°F (32°C) Note At T2, the fan speed increases to Speed 1.
Speed 1	56%	<ul style="list-style-type: none"> T1—82.4°F (28°C) T4—102.2°F (39°C) Note At T1, the fan speed decreases to Speed 0. At T4, the fan speed increases to Speed 2.
Speed 2	75%	T3—95.0°F (35°C) T6—116.6°F (47°C) Note At T3, the fan speed decreases to Speed 1. At T6, the fan speed increases to Speed 3.
Speed 3 ²	100%	T5—Greater than 109.4°F (43°C)

1. Pulse-Width Modulation

2. Speed 3 is a fixed value and cannot be altered.

Catalyst 4948E Fan Tray (WS-X4993=)

The Catalyst 4948E fan tray (WS-X4993) contains four variable-speed, 12 VDC fans. (See Figure 1-3.) The fan tray is mounted in the rear of the chassis between the two power supplies.

Note

The WS-X4993 fan tray is not interchangeable with the WS-X4993-F fan tray.

Figure 1-3 Catalyst 4948E Fan Tray

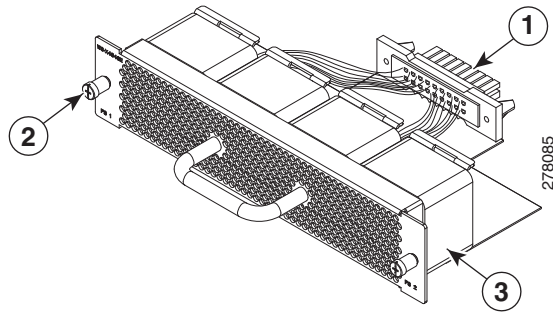

1	Backplane connector	3	12 VDC fan (4X). Air is drawn in from the front of the chassis and exhausted through the rear of the chassis.
2	Captive installation screw (2X)		

The fan tray draws in air through vents at the front of the chassis and exhausts it through the rear of the chassis as shown in [Figure 1-4](#).

Figure 1-4 Catalyst 4948E Chassis Airflow

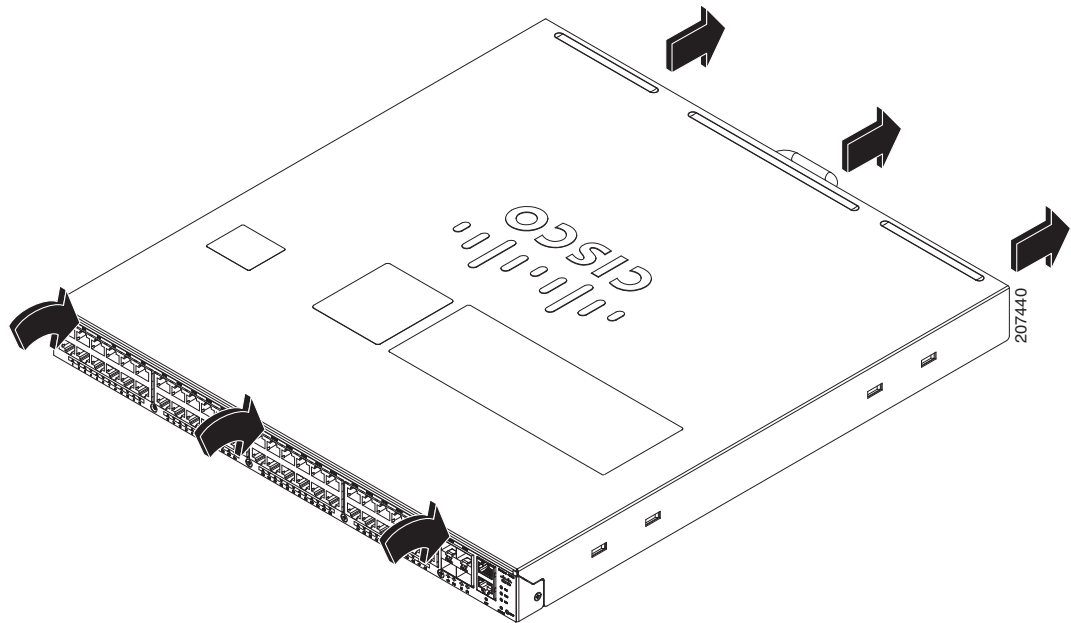

Catalyst 4948E-F Fan Tray (WS-X4993-F=)

The Catalyst 4948E-F chassis fan tray (WS-X4993-F=) contains four variable-speed, 12 VDC fans. (See [Figure 1-5](#).) The fan tray is mounted in the rear of the chassis between the two power supplies.

Note

The WS-X4993-F fan tray is keyed to prevent insertion into the Catalyst 4948E switch chassis.

Figure 1-5 Catalyst 4948E-F Fan Tray

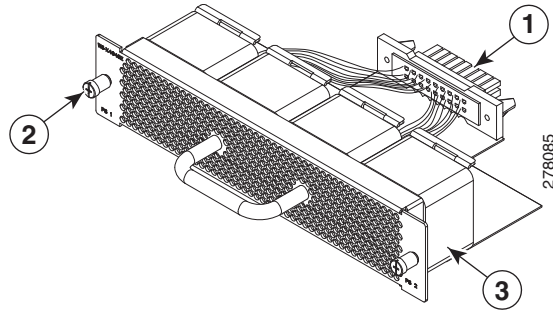

1	Backplane connector	3	12 VDC fan (4X). Air is drawn in from the rear of the chassis and exhausted through the front of the chassis.
2	Captive installation screw (2X)		

The fan tray draws in air through vents at the rear of the chassis and exhausts it through the front of the chassis as shown in [Figure 1-6](#).

Figure 1-6 Catalyst 4948E-F Chassis Airflow

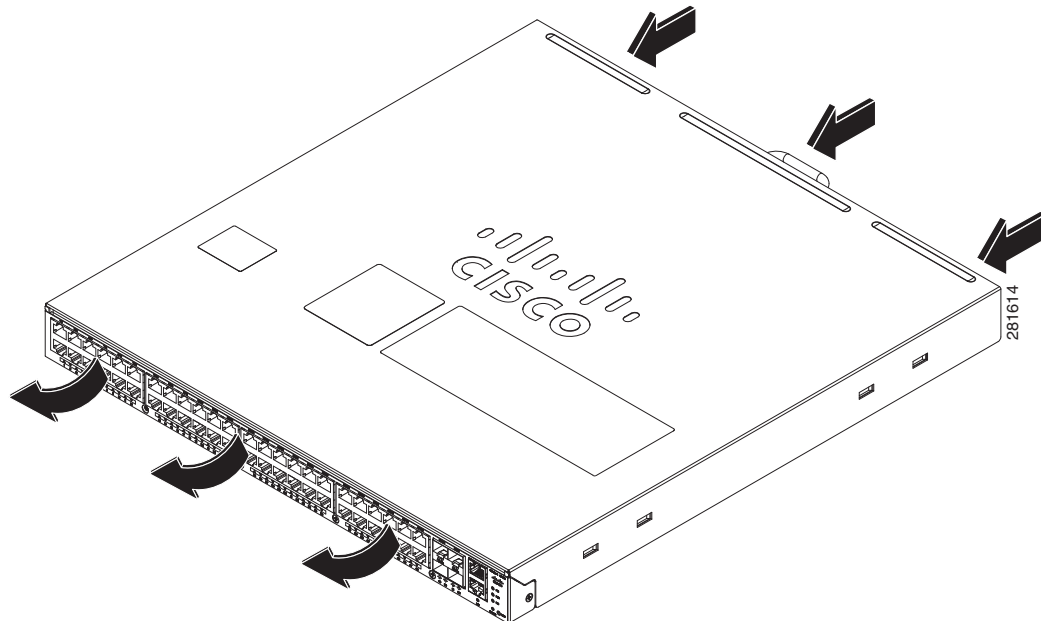

Front Panel LEDs

A set of LEDs on the chassis front panel provide visual status for the switch. (See [Figure 1-7](#).) [Table 1-5](#) lists the Catalyst 4948E and Catalyst 4948E-F switch chassis front panel LEDs and their meanings.

Figure 1-7 Front Panel LEDs

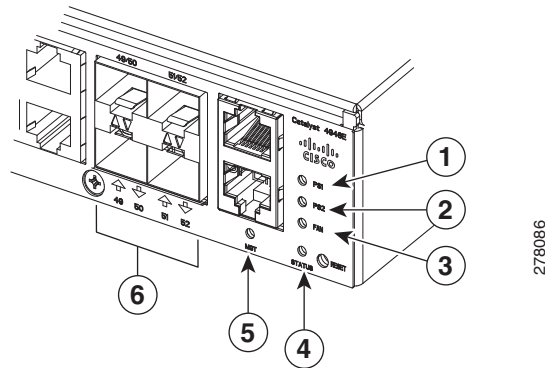

1	PS1 (power supply 1)	4	STATUS
2	PS2 (power supply 2)	5	MGT (management port LED)
3	FAN (fan tray)	6	LINK (port status). One LED for each uplink and downlink port.

Table 1-5 Front Panel LED Descriptions

LED	State and Meaning
STATUS	Green—The system is up and running. Red—System fault. Flashing amber—Power-on self-test (POST) boot up. Off—System is not powered up.
LINK 48 10/100/1000 downlink port LEDs and 4 SFP/SFP+ uplink port LEDs	Green—Link is established. Amber—Administrative disabled. Off—No link is detected.
FAN (Fan tray)	Green—Fan tray OK. Red—One or more fan failures.
PS1 (Power supply 1) ¹	Green—AC-input or DC-input power is OK. Red—Power supply fault detected.
PS2 (Power supply 2) ¹	Green—AC-input or DC-input power is OK. Red—Power supply fault detected.

1. There are three additional LEDs mounted on the power supply front panel that provide power supply status. These LEDs are only visible from the back of the chassis. For a description of the LEDs, see the “[300 W AC-Input Power Supply \(PWR-C49E-300AC-R\)](#)” section on page A-1.



CHAPTER 2

Preparing for Installation

Revised: July 2012

Planning a proper location for the switch and the layout of your equipment rack or wiring closet is essential for successful system operation. Equipment placed too close together or inadequately ventilated can cause system overtemperature conditions. In addition, poor equipment placement can make network interface connections inaccessible and difficult to maintain.

This chapter describes how to prepare your site for switch installation and includes these sections:

- [Safety, page 2-1](#)
- [Site Requirements, page 2-2](#)
- [System Grounding, page 2-7](#)
- [Power Requirements, page 2-11](#)
- [Cabling Requirements, page 2-13](#)
- [Site Preparation Checklist, page 2-13](#)



Tip

For additional information about the Cisco Catalyst 4948E or the Catalyst 4948E-F switch (including configuration examples and troubleshooting information), see the documents listed on this page:

http://www.cisco.com/en/US/products/ps6021/tsd_products_support_series_home.html

Safety

Safety warnings appear throughout this publication in procedures that may harm you if performed incorrectly. A warning symbol precedes each warning statement. The warnings below are general warnings that are applicable to the entire publication.



Warning

Only trained and qualified personnel should be allowed to install, replace, or service this equipment.
Statement 1030

**Warning**

This unit is intended for installation in restricted access areas. A restricted access area can be accessed only through the use of a special tool, lock and key, or other means of security.

Statement 1017

**Warning**

Voltages that present a shock hazard may exist on Power over Ethernet (PoE) circuits if interconnections are made using uninsulated exposed metal contacts, conductors, or terminals. Avoid using such interconnection methods, unless the exposed metal parts are located within a restricted access location and users and service people who are authorized within the restricted access location are made aware of the hazard. A restricted access area can be accessed only through the use of a special tool, lock and key or other means of security. Statement 1072

Site Requirements

These following sections describe some of the basic site requirements that you should be aware of as you prepare to install your Catalyst 4948E or Catalyst 4948E-F switch:

- [Rack-Mounting Guidelines, page 2-2](#)
- [Temperature, page 2-3](#)
- [Air Flow, page 2-4](#)
- [Humidity, page 2-5](#)
- [Altitude, page 2-5](#)
- [Dust and Particulates, page 2-5](#)
- [Corrosion, page 2-6](#)
- [Electromagnetic and Radio Frequency Interference, page 2-6](#)
- [Shock and Vibration, page 2-7](#)
- [Maintaining Safety with Electricity, page 2-9](#)
- [Preventing Electrostatic Discharge Damage, page 2-10](#)

Rack-Mounting Guidelines

A rack-mount kit (69-2037-xx) is included in the accessory kit for mounting the switch in a standard 19-inch (48.3 cm) equipment rack. This rack-mount kit is not suitable for use in the following situations:

- Racks with obstructions (such as power strips) that could impair access to the switch

Before rack-mounting the switch, ensure the following:

- The equipment rack is the proper size.
 - The width of the rack, between the two front-mounting strips or rails, must be 17.75 inches (45.09 cm).
 - The depth of the rack, between the front- and rear-mounting strips, must be at least 19.25 inches (48.9 cm) but not more than 32.5 inches (82.5 cm).
 - The rack must have sufficient vertical clearance to insert the chassis. The chassis height is 1 U (1.75 inches (4.45 cm)).

- The equipment rack is stable and in no danger of falling over.
 - Ensure that the shelf is constructed to support the weight and dimensions of the chassis.
 - We recommend that you bolt the rack to the floor.
 - Mount the unit at the bottom of the rack if it is the only unit in the rack.
 - Install heavier equipment in the lower half of the rack to maintain a low center of gravity and prevent the rack from becoming top-heavy and tipping over.
 - Install the stabilizers before mounting or servicing the switch in the rack (if the rack is provided with stabilizing devices).
- The equipment rack is properly ventilated.
 - Install the chassis in an enclosed rack only if it has adequate ventilation or an exhaust fan; use an open rack whenever possible.
 - Ensure that the ambient temperature of the rack environment does not exceed a maximum temperature of 104°F (40°C). If the switch is installed in a closed or multiunit rack assembly, the ambient operating temperature of the rack environment might be higher than the ambient room temperature.
 - Ensure that the ventilation system in a closed rack does not prevent cooling by creating negative pressure around the chassis and redirecting the air away from the chassis intake vent. If necessary, operate the chassis with the rack open.
 - Ensure that equipment installed near the bottom of a rack does not generate excessive heat, which can be drawn upward and into the air intakes of equipment above. This situation can cause overtemperature conditions in the chassis at or near the top of the rack.
 - Consider the equipment and cabling that is already installed in the rack. Ensure that cables from other equipment will not obstruct the airflow through the chassis or impair access to the power supplies or switching modules. Route cables away from field-replaceable components to avoid disconnecting cables unnecessarily for equipment maintenance or upgrades.
 - Allow at least 3 to 4 feet (91.4 to 121.9 cm) of clearance behind the rack for maintenance and removal of switch assemblies. If the rack is mobile, you can push it back within 1 foot (30.45 cm) of a wall or cabinet for normal operation and pull it out when necessary for maintenance.

Temperature

Temperature extremes can cause a system to operate at reduced efficiency and cause a variety of problems, including premature aging and failure of chips, and failure of mechanical devices. Extreme temperature fluctuations can cause chips to become loose in their sockets. Observe the following guidelines:

- Ensure that the system is operating in an environment no colder than 50°F (10°C) or hotter than 104°F (40°C).
- Ensure that the chassis has adequate ventilation.
- Use proper air circulation management techniques. Chassis mounted higher in a rack enclosure are susceptible to higher ambient air temperatures due to the heat generated from chassis that are mounted below the chassis in the rack.
- Do not place the chassis within a closed-in wall unit or on top of cloth, which can act as insulation.
- Do not place the chassis where it will receive direct sunlight, particularly in the afternoon.
- Do not place the chassis next to a heat source of any kind, including heating vents.

- Ensure that all slots and openings on a chassis remain unobstructed, especially the fan tray vent at the back of the chassis. Adequate ventilation is particularly important at high altitudes where the air is thinner.
- Clean the installation site at regular intervals to avoid buildup of dust and debris, which can cause a system to overheat.
- Allow a 2-hour warm-up period to bring the chassis up to normal operating temperature before turning it on for chassis that have been exposed to abnormally cold temperatures.

Failure to observe these guidelines can damage internal chassis components.



Note

The Catalyst 4948E and the Catalyst 4948E-F switches are equipped with internal air temperature sensors that are triggered above 104°F (40°C) generating a minor alarm and above 131°F (55°C) generating a major alarm. Enter the command **show environment status** to determine the exact temperature when the alarms are generated.

Air Flow

The Catalyst 4948E and Catalyst 4948E-F switches are designed to be installed in an environment where there is a sufficient volume of air available to cool the chassis and the power supplies. Any constraints placed on the free flow of air through the chassis or an elevated ambient air temperature can cause the switch to overheat and shut down.

To maintain proper air circulation through the switch chassis, we recommend that you maintain a minimum 6-inch (15 cm) separation between a wall and the chassis hot air exhaust. Failure to maintain adequate spacing between chassis can cause the switch chassis that is drawing in the hot exhaust air to overheat and fail.

If you are installing your Catalyst 4948E or Catalyst 4948E-F switch chassis in an enclosed or partially enclosed rack, we strongly recommend that you verify that your site meets the following guidelines:

- Verify that the ambient air temperature within the enclosed or partially enclosed rack is within the chassis operating temperature limits. After installing the chassis in the rack, power up the chassis and allow the chassis temperature to stabilize (approximately 2 hours). Measure the ambient air temperature at the chassis air intake grill and at the chassis air exhaust grill by positioning an external temperature probe approximately 1 inch (2.5 cm) away from the grills.
 - If the ambient intake air temperature is less than 104°F (40°C), the rack meets the intake air temperature criterion.
 - If the ambient intake air temperature exceeds 104°F (40°C), the system might experience minor temperature alarms and is in danger of overheating.
 - If the ambient intake air temperature equals or is greater than 131°F (55°C), the system will experience a major temperature alarm and shut down.
- Verify that the enclosed or partially enclosed rack allows an adequate flow of air through the switch chassis as follows:
 - If the difference between the measured intake air temperature and the exhaust air temperature does not exceed 10°C, there is sufficient airflow in the rack.
 - If the difference in air temperature exceeds 10°C, there is insufficient airflow to cool the chassis.

**Note**

The 10°C temperature differential between the intake and the exhaust must be determined by taking measurements using external digital temperature probes. Do not use the chassis internal temperature sensors to measure the temperature differential.

- Plan for future growth. Your Catalyst 4948E or Catalyst 4948E-F switches currently installed in an enclosed or partially enclosed rack might meet ambient air temperature and air flow requirements now. However, if you add more chassis or other equipment to the rack, the additional heat generated might cause the ambient air temperature within the rack to exceed 104°F (40°C) and can cause minor alarms.
- If you are installing the Catalyst 4948E-F in a data center that uses the hot isle and cold isle style of cooling, we recommend that you use an optional inlet air duct to extend the chassis air intake to the cold isle. Panduit Corporation manufactures a Modular ToR Switch Inlet Duct (Model CDE2) that can be installed along with the Catalyst 4948E-F chassis to extend the switch chassis air intake to the cold isle at the front of the rack enclosure.

Humidity

High-humidity conditions can cause moisture migration and penetration into the system. This moisture can cause corrosion of internal components and degradation of properties such as electrical resistance, thermal conductivity, physical strength, and size. Extreme moisture buildup inside the system can result in electrical shorts, which can cause serious damage to the system. Each system is rated to operate at 8 to 80 percent relative humidity, with a humidity gradation of 10 percent per hour. In storage, a system can withstand from 5 to 95 percent relative humidity. Buildings in which climate is controlled by air-conditioning in the warmer months and by heat during the colder months usually maintain an acceptable level of humidity for system equipment. However, if a system is located in an unusually humid location, a dehumidifier can be used to maintain the humidity within an acceptable range.

Altitude

Operating a system at high altitude (low pressure) reduces the efficiency of forced and convection cooling and can result in electrical problems related to arcing and corona effects. This condition can also cause sealed components with internal pressure, such as electrolytic capacitors, to fail or perform at reduced efficiency. Each system is rated to operate at altitudes from –50 to 6500 feet (–16 to 1981 meters) and can be stored at altitudes of –50 to 35,000 feet (–16 to 10,668 meters).

Dust and Particulates

Fans cool the power supplies and the system components by drawing in room temperature air, circulating the air through the power supplies and the chassis, and exhausting the heated air out through various openings in the chassis. However, fans also ingest dust and other particulates, causing contaminant buildup on the fan blades and in the system. This can create a thermal blanket on components increasing the internal chassis temperature.

A clean operating environment can greatly reduce the negative effects of dust and other particulates. The standards listed below provide guidelines for acceptable working environments and acceptable levels of suspended particulate matter:

- Network Equipment Building Systems (NEBS) GR-63-CORE

- National Electrical Manufacturers Association (NEMA) Type 1
- International Electrotechnical Commission (IEC) IP-20

Corrosion

Corrosion of system connectors is a gradual process that can eventually lead to intermittent failures of electrical circuits. The oil from a person's fingers or prolonged exposure to high temperature or humidity can corrode the gold-plated edge connectors and pin connectors on various components in the system. To prevent corrosion, avoid touching contacts on boards and cards, and protect the system from extreme temperatures and moist, salty environments.

Electromagnetic and Radio Frequency Interference

Electromagnetic interference (EMI) and radio frequency interference (RFI) from a system can adversely affect devices such as radio and television (TV) receivers operating near the system. Radio frequencies emanating from a system can also interfere with cordless and low-power telephones. Conversely, RFI from high-power telephones can cause spurious characters to appear on the system monitor. RFI is defined as any EMI with a frequency above 10 kilohertz (kHz). This type of interference can travel from the system to other devices through the power cable and power source or through the air like transmitted radio waves. The Federal Communications Commission (FCC) publishes specific regulations to limit the amount of EMI and RFI emitted by computing equipment. Each system meets these FCC regulations. To reduce the possibility of EMI and RFI, follow these guidelines:

- Only operate the system with the chassis covers installed.
- Ensure that an unused power supply bay has a metal cover plate installed.
- Ensure that the screws on all peripheral cable connectors are securely fastened to their corresponding connectors on the back of the chassis.
- Always use shielded cables with metal connector shells for attaching peripherals to the system.

When wires are run for any significant distance in an electromagnetic field, interference can occur between the field and the signals on the wires. This fact has two implications for the construction of plant wiring:

- Bad wiring practice can result in radio interference emanating from the plant wiring.
- Strong EMI, especially when it is caused by lightning or radio transmitters, can destroy the signal drivers and receivers in the chassis, and even create an electrical hazard by conducting power surges through lines into equipment.



Note

To predict and remedy strong EMI, you may also need to consult experts in radio frequency interference (RFI).

If you use twisted-pair cable in your plant wiring with a good distribution of grounding conductors, the plant wiring is unlikely to emit radio interference. If you exceed the recommended distances, use a high-quality twisted-pair cable with one ground conductor for each data signal when applicable.



Caution

Category 5e, Category 6, and Category 6a cables can store large levels of static electricity because of the dielectric properties of the materials used in their construction. Always ground the cables (especially in new cable runs) to a suitable and safe earth ground before connecting them to the module.

If the wires exceed the recommended distances, or if wires pass between buildings, give special consideration to the effect of a lightning strike in your vicinity. The electromagnetic pulse caused by lightning or other high-energy phenomena can easily couple enough energy into unshielded conductors to destroy electronic devices. If you previously have had similar problems, you might want to consult experts in electrical surge suppression and shielding.

Shock and Vibration

Catalyst 4948E and Catalyst 4948E-F switches have been shock- and vibration-tested for operating ranges, handling, and earthquake standards to NEBS (Zone 4 per GR-63-Core). These tests have been conducted in earthquake environment and criteria, office vibration and criteria, transportation vibration and criteria, and packaged equipment shock.

Power Source Interruptions

Systems are especially sensitive to variations in voltage supplied by the AC power source. Overvoltage, undervoltage, and transients (or spikes) can erase data from memory or even cause components to fail. To protect against these types of problems, power cables should always be properly grounded. Also, place the system on a dedicated power circuit (rather than sharing a circuit with other heavy electrical equipment). In general, do not allow the system to share a circuit with any of the following:

- Copy machines
- Air conditioners
- Vacuum cleaners
- Space heaters
- Power tools
- Teletype machines
- Laser printers
- Facsimile machines
- Any other motorized equipment

Besides these appliances, the greatest threats to a system power supply are surges or blackouts that are caused by electrical storms. Whenever possible, turn off the system and any peripherals, and unplug them from their power sources during thunderstorms. If a blackout occurs—even a temporary one—while the system is turned on, turn off the system immediately and disconnect it from the electrical outlet. Leaving the system on may cause problems when the power is restored; all other appliances left on in the area can create large voltage spikes that can damage the system.

System Grounding

You must install a NEBS-compliant system ground as part of the chassis installation process. Chassis installations that rely only on the AC third-prong ground are insufficient to properly and adequately ground the systems. Both chassis comes with a ground lug and two M4 bolts as part of the accessory kit. The lug attaches to the chassis grounding pad with the two bolts. A 6 AWG copper wire (not provided) must be used to connect the ground lug to the NEBS-compliant building ground.

Proper grounding practices ensure that the buildings and the installed equipment within them have low-impedance connections and low-voltage differentials between chassis. When you include NEBS-compliant system grounds, you reduce or prevent shock hazards, greatly reduce the chances of equipment damage due to transients, and substantially reduce the potential for data corruption.

Without proper and complete system grounding, you run the risk of increased component damage due to ESD. Additionally, you have a greatly increased chance of data corruption, system lockup and frequent system reboot situations by not using a system (NEBS compliant) ground.

**Caution**

Installations that rely solely on system grounding using only an AC third-prong ground run a substantially greater risk of equipment problems and data corruption than those installations that use both the AC third-prong ground and a properly installed system (NEBS compliant) ground.

Table 2-1 lists some general grounding practice guidelines.

Table 2-1 **Grounding Practice Guidelines**

Environment	Electromagnetic Noise Severity Level	Grounding Recommendations
Commercial building is subjected to direct lightning strikes. For example, some places in the United States, such as Florida, are subject to more lightning strikes than other areas.	High	All lightning protection devices must be installed in strict accordance with manufacturer recommendations. Conductors carrying lightning current should be spaced away from power and data lines in accordance with applicable recommendations and codes. Best grounding practices must be closely followed.
Commercial building is located in an area where lightning storms frequently occur but is not subject to direct lightning strikes.	High	Grounding best practices must be closely followed.
Commercial building contains a mix of information technology equipment and industrial equipment, such as welding.	Medium to High	Grounding best practices must be closely followed.
Existing commercial building is not subject to natural environmental noise or man-made industrial noise. This building contains a standard office environment. This installation has a history of malfunction due to electromagnetic noise.	Medium	Grounding best practices must be closely followed. Determine source and cause of noise if possible, and mitigate as closely as possible at the noise source or reduce coupling from the noise source to the victim equipment.

Table 2-1 Grounding Practice Guidelines (continued)

Environment	Electromagnetic Noise Severity Level	Grounding Recommendations
New commercial building is not subject to natural environmental noise or man-made industrial noise. This building contains a standard office environment.	Low	Grounding best practices should be followed as closely as possible. Electromagnetic noise problems are not anticipated, but installing a best practice grounding system in a new building is often the least expensive route and the best way to plan for the future.
Existing commercial building is not subject to natural environmental noise or man-made industrial noise. This building contains a standard office environment.	Low	Grounding best practices should be followed as much as possible. Electromagnetic noise problems are not anticipated, but installing a best practice grounding system is always recommended.

**Note**

In all situations, grounding practices must comply with Section 250 of the National Electric Code (NEC) requirements or local laws and regulations. A 6 AWG grounding wire is preferred from the chassis to the rack ground or directly to the common bonding network (CBN). The equipment rack should also be connected to the CBN with 6 AWG grounding wire.

**Caution**

Category 5e, Category 6, and Category 6a cables can store large levels of static electricity because of the dielectric properties of the materials used in their construction. Always ground the cables (especially in new cable runs) to a suitable and safe earth ground before connecting them to the port on the switch.

Maintaining Safety with Electricity

When working on electrical equipment, follow these guidelines:

- Do not work alone if potentially hazardous conditions exist anywhere in your work space.
- Never assume that power is disconnected from a circuit; always check the circuit before working on it.
- Look carefully for possible hazards in your work area, such as damp floors, ungrounded power extension cables, frayed or damaged power cords, and missing safety grounds.
- If an electrical accident occurs, proceed as follows:
 - Use extreme caution; do not become a victim yourself.
 - Disconnect power from the system.
 - If possible, send another person to get medical aid. Otherwise assess the condition of the victim, and then call for help.
 - Determine if the person needs rescue breathing or external cardiac compressions; then take appropriate action.
- Use the product within its marked electrical ratings and product usage instructions.
- Install the product in compliance with local and national electrical codes.

- If any of the following conditions occur, contact the Cisco Technical Assistance Center:
 - The power cable or plug is damaged.
 - An object has fallen into the product.
 - The product has been exposed to water or other liquids.
 - The product has been dropped or shows signs of damage.
 - The product does not operate correctly when you follow the operating instructions.
- Use the correct external power source. Operate the product only from the type of power source indicated on the electrical ratings label. If you are not sure of the type of power source required, consult the Cisco Technical Assistance Center or a local electrician.
- Use approved power cables only. You have been provided with one or more power cables with your chassis power supply that are intended for use in your country, based on the shipping location. Should you need to purchase additional power cables, ensure that they are rated for the product and for the voltage and current marked on the product's electrical ratings label. The voltage and current rating of the power cable should be greater than the ratings marked on the label.
- To help prevent electrical shock, plug all power cables into properly grounded electrical outlets. These power cables are equipped with three-prong plugs to help ensure proper grounding. Do not use adapter plugs or remove the grounding prong from a power cable.
- Observe power strip ratings. Make sure that the total current rating of all products that are plugged into the power strip does not exceed 80 percent of the power strip rating.
- Do not modify power cables or plugs yourself. Consult with a licensed electrician or your power company for site modifications. Always follow your local and national wiring codes.

Preventing Electrostatic Discharge Damage

Electrostatic discharge (ESD) damage, which can occur when modules or other FRUs are improperly handled, results in intermittent or complete failures. Modules consist of printed circuit boards that are fixed in metal carriers. Electromagnetic interference (EMI) shielding and connectors are integral components of the carrier. Although the metal carrier helps to protect the board from ESD, always use an ESD grounding strap when handling modules.

To prevent ESD damage, follow these guidelines:

- Always use an ESD wrist strap and ensure that it makes maximum contact with bare skin. ESD grounding straps are available with banana plugs, metal spring clips, or alligator clips. If you choose to use the disposable ESD wrist strap supplied with most FRUs or an ESD wrist strap equipped with an alligator clip, you must attach the system ground lug to the chassis in order to provide a proper grounding point for the ESD wrist strap.



Note This system ground is also referred to as the network equipment building system (NEBS) ground.

- If your chassis does not have the system ground attached, you must install the system ground.

After you install the system ground lug, follow these steps to correctly attach the ESD wrist strap:

-
- Step 1** Attach the ESD wrist strap to bare skin as follows:
- a. If you are using the ESD wrist strap supplied with the FRUs, open the wrist strap package and unwrap the ESD wrist strap. Place the black conductive loop over your wrist and tighten the strap so that it makes good contact with your bare skin.
 - b. If you are using an ESD wrist strap equipped with an alligator clip, open the package and remove the ESD wrist strap. Locate the end of the wrist strap that attaches to your body and secure it to your bare skin.
- Step 2** Grasp the spring or alligator clip on the ESD wrist strap and momentarily touch the clip to a bare metal spot (unpainted surface) on the rack. We recommend that you touch the clip to an unpainted rack rail so that any built-up static charge is then safely dissipated to the entire rack.
- Step 3** Attach either the spring clip or the alligator clip to the ground lug screw as follows:
- a. If you are using the ESD wrist strap that is supplied with the FRUs, squeeze the spring clip jaws open, position the spring clip to one side of the system ground lug screw head, and slide the spring clip over the lug screw head so that the spring clip jaws close behind the lug screw head.
-  **Note** The spring clip jaws do not open wide enough to fit directly over the head of the lug screw or the lug barrel.
- b. If you are using an ESD wrist strap that is equipped with an alligator clip, attach the alligator clip directly over the head of the system ground lug screw or to the system ground lug barrel.

**Caution**

For safety, periodically check the resistance value of the antistatic strap. The measurement should be between 1 and 10 megohm (Mohm).

Power Requirements

When preparing your site for the switch installation, follow these general requirements:

- In systems configured with two power supplies, connect each of the two power supplies to a separate input power source. If you fail to do this, your system might be susceptible to total power failure due to a fault in the external wiring or a tripped circuit breaker.
- To prevent a loss of input power, be sure that the total maximum load on each source circuit is within the current ratings of the wiring and breakers.
- In some systems, you may decide to use an uninterruptible power supply (UPS) to protect against power failures at your site. Be aware when selecting a UPS that some UPS models that use ferroresonant technology can become unstable when operating with the power supplies which use power factor correction (PFC). This can cause the output voltage waveform to the switch to become distorted resulting in an undervoltage situation in the system.

Power Connection Guidelines for AC-Powered Systems

This section provides some basic guidelines for connecting the AC power supplies to the site power source:

- Each chassis power supply should have a separate, dedicated branch circuit.
- For North America:
 - The 300 W power supply requires a 15 A circuit.
- For International:
 - Circuits should be sized according to local and national codes.
- If you are using a 200/240 VAC power source in North America, the circuit must be protected by a two-pole circuit breaker.
- The source AC outlet must be within 6 feet (1.8 meters) of the system and should be easily accessible.
- The AC power receptacles used to plug in the chassis must be the grounding type. The grounding conductors that connect to the receptacles should connect to protective earth ground at the service equipment.

Power Connection Guidelines for DC-Powered Systems

This section provides the basic guidelines for connecting the Catalyst 4948E switch DC-input power supplies to the site power source:

- All power connection wiring should conform to the rules and regulations in the National Electrical Code (NEC), as well as any local codes.
- The DC return must remain isolated from the system frame and the chassis (DC-I).
- For DC power cables, we recommend that you use commensurately rated, high-strand-count copper wire cable. Connection to the DC-input power supply requires one earth ground cable, one source DC (–), and one source DC return (+). The length of the cables depends on your switch location. The cables and the lugs required to attach the source DC cables to the power supply are not available from Cisco Systems. They are available from any commercial cable vendor.
- The color coding of the source DC power cable leads depends on the color coding of the site DC power source. Typically, green or green and yellow indicate that the cable is a ground cable. Because there is no color code standard for source DC wiring, you must ensure that the power cables are connected to the DC-input power supply terminal block in the proper (+) and (–) polarity. In some cases, the source DC cable leads might have a positive (+) or a negative (–) label. This label is a relatively safe indication of the polarity, but you must verify the polarity by measuring the voltage between the DC cable leads. When making the measurement, the positive (+) lead and the negative (–) lead must always match the (+) and (–) labels on the DC-input power supply terminal block.
- DC power cables must be terminated by cable lugs at the power supply end.
- The circuit breaker is considered to be the disconnect device and should be easily accessible.
- The circuit must be protected by a dedicated two-pole circuit breaker. The circuit breaker should be sized according to the power supply input rating and local or national code requirements.

Cabling Requirements

**Caution**

The intrabuilding port(s) of the equipment or subassembly is suitable for connection to intrabuilding or unexposed wiring or cabling only. The intrabuilding port(s) of the equipment or subassembly must not be metallically connected to interfaces that connect to the Outside Plant (OSP) or its wiring. These interfaces are designed for use as intrabuilding interfaces only (Type 2 or Type 4 ports as described in GR-1089-CORE, Issue 4) and require isolation from the exposed OSP cabling. The addition of Primary Protectors is not sufficient protection to connect these interfaces metallically to OSP wiring.

When running power and data cables together in overhead cable trays or subfloor cable trays, be aware of the following caution:

**Caution**

We strongly recommend that power cabling runs and other potential noise sources be located as far away as practical from LAN cabling that terminates on Cisco equipment. In situations, where this type of long parallel cable runs exist, which cannot be separated by at least 3.3 feet (1 meter), we recommend that you shield these potential noise sources. To avoid interference, the source should be shielded by housing it in a grounded metallic conduit.

Also be aware of the following caution concerning the use of Category 5e and Category 6 Ethernet cables:

**Caution**

Category 5e, Category 6, and Category 6a cables can store large levels of static electricity because of the dielectric properties of the materials used in their construction. Always ground the cables (especially in new cable runs) to a suitable and safe earth ground before connecting them to the module.

Site Preparation Checklist

[Table 2-2](#) lists the site planning activities that you should perform prior to installing the switch. Completing each activity helps ensure a successful switch installation.

Table 2-2 Site Planning Checklist

Task No.	Planning Activity	Verified By	Time	Date
1	Space evaluation: <ul style="list-style-type: none"> • Space and layout • Floor covering • Impact and vibration • Lighting • Maintenance access 			
2	Environmental evaluation: <ul style="list-style-type: none"> • Ambient temperature • Humidity • Altitude • Atmospheric contamination • Airflow 			
3	Power evaluation: <ul style="list-style-type: none"> • Input power type • Power receptacles (Depends on power supply)¹ • Receptacle proximity to the equipment • Dedicated (separate) circuits for redundant power supplies • UPS for power failures² • DC systems: Proper gauge wire and lugs 			
4	Grounding evaluation: <ul style="list-style-type: none"> • Circuit breaker size • CO ground (AC- and DC-powered systems) 			
5	Cable and interface equipment evaluation: <ul style="list-style-type: none"> • Cable type • Connector type • Cable distance limitations • Interface equipment (transceivers) 			
6	EMI evaluation: <ul style="list-style-type: none"> • Distance limitations for signaling • Site wiring • RFI levels 			

1. Verify that each power supply installed in the chassis has a dedicated AC source or DC source circuit.
2. Refer to the power supply's kVA rating as a sizing criteria in determining the output required by the UPS. The power supply's kVA rating value is listed in the specifications table for each power supply in Appendix A.

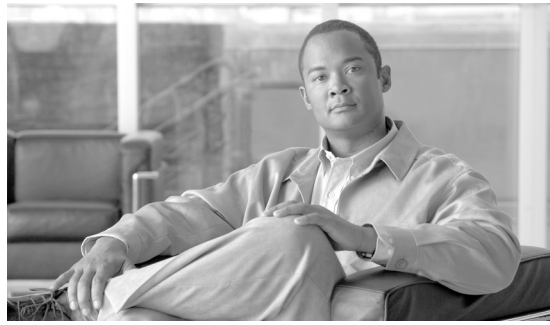

CHAPTER 3

Installing the Switch

Revised: January 4, 2012

This chapter describes how to install the Catalyst 4948E switch in an equipment rack.

- [Preparing to Install the Chassis, page 3-1](#)
- [Rack-Mounting the Chassis, page 3-5](#)
- [Installing the System Ground, page 3-10](#)
- [Connecting Power to the Switch, page 3-12](#)
- [Attaching the Interface Cables, page 3-15](#)
- [Powering Up the Switch, page 3-21](#)



Note

Before starting the installation procedures in this chapter, complete the site planning checklist in [Chapter 2, “Preparing for Installation”](#) to verify that all planning activities were completed.

Preparing to Install the Chassis

This section covers these topics:

- [Warnings, page 3-2](#)
- [Verifying Package Contents, page 3-4](#)
- [Required Tools, page 3-4](#)
- [Lifting the Chassis Safely, page 3-5](#)



Tip

For additional information about the Cisco Catalyst 4948E and the Catalyst 4948E-F switches (including configuration examples and troubleshooting information), see the documents listed on this page:

http://www.cisco.com/en/US/products/ps6021/tsd_products_support_series_home.html

Warnings

The installation-applicable warnings are listed below. Warning translations in multiple languages are provided in Appendix D. Refer to the statement number for the translations.



Warning

To prevent the switch from overheating, do not operate it in an area that exceeds the maximum recommended ambient temperature of 104°F (40°C). To prevent airflow restriction, allow at least 3 inches (7.6 cm) of clearance around the ventilation openings. Statement 17



Warning

This unit is intended for installation in restricted access areas. A restricted access area is where access can only be gained by service personnel through the use of a special tool, lock and key, or other means of security, and is controlled by the authority responsible for the location. Statement 37



Warning

This equipment is intended to be grounded. Ensure that the host is connected to earth ground during normal use. Statement 39



Warning

Before working on equipment that is connected to power lines, remove jewelry (including rings, necklaces, and watches). Metal objects will heat up when connected to power and ground and can cause serious burns or weld the metal object to the terminals. Statement 43



Warning

Do not stack the chassis on any other equipment. If the chassis falls, it can cause severe bodily injury and equipment damage. Statement 48



Warning

Ethernet cables must be shielded when used in a central office environment. Statement 171



Warning

Do not work on the system or connect or disconnect cables during periods of lightning activity. Statement 1001



Warning

Read the installation instructions before connecting the system to the power source. Statement 1004

**Warning**

To prevent bodily injury when mounting or servicing this unit in a rack, you must take special precautions to ensure that the system remains stable. The following guidelines are provided to ensure your safety:

- This unit should be mounted at the bottom of the rack if it is the only unit in the rack.
- When mounting this unit in a partially filled rack, load the rack from the bottom to the top with the heaviest component at the bottom of the rack.
- If the rack is provided with stabilizing devices, install the stabilizers before mounting or servicing the unit in the rack. Statement 1006

**Warning**

Class 1 laser product. Statement 1008

**Warning**

This unit is intended for installation in restricted access areas. A restricted access area can be accessed only through the use of a special tool, lock and key, or other means of security.

Statement 1017

**Warning**

Only trained and qualified personnel should be allowed to install, replace, or service this equipment.

Statement 1030

**Warning**

Ultimate disposal of this product should be handled according to all national laws and regulations.

Statement 1040

**Warning**

This product requires short-circuit (overcurrent) protection, to be provided as part of the building installation. Install only in accordance with national and local wiring regulations. Statement 1045

**Warning**

When installing or replacing the unit, the ground connection must always be made first and disconnected last. Statement 1046

**Warning**

Invisible laser radiation may be emitted from disconnected fibers or connectors. Do not stare into beams or view directly with optical instruments. Statement 1051

**Warning**

Installation of the equipment must comply with local and national electrical codes. Statement 1074

Verifying Package Contents

Carefully remove the chassis and accessory kit from the shipping container, and check each item for damage. If any item is missing or damaged, contact your Cisco representative or reseller for support. Return all packing material to the shipping container, and save it.

The chassis is shipped with these items in the accessory kit:

- One RJ-45 female-to-DB-9 female adapter plug
- System ground kit
- Rack-mounting kit that contains the following items:
 - Two 19-inch rack-mounting brackets
 - Eight M4 x 8 mm Phillips flat-head screws for attaching the brackets to the switch
 - Four 12-24 x 3/4-inch and four 10-32 x 3/4-inch Phillips machine screws for attaching the rack-mount brackets to a rack
 - Disposable ESD wrist strap

**Note**

A console cable is not provided in the accessory kit. It can be ordered as an option.

Required Tools

To properly install the chassis, you need the following tools and equipment:

- No. 1 Phillips screwdriver
- No. 2 Phillips screwdriver
- 3/16-inch flat-blade screwdriver
- Antistatic mat or antistatic foam
- Your own ESD grounding strap or the disposable ESD strap included with the system
- Tape measure and level
- Copper system ground wire (the required wire gauge is determined by local or national electrical codes)
- Source DC power cables (the required wire gauge is determined by local or national electrical codes)
- Either insulated crimp-on spade lugs or insulated crimp-on ring connectors (the required size and style is determined by local or national electrical codes)
- Wire-stripping tool
- Crimping tool

Lifting the Chassis Safely

Whenever you lift a chassis, follow these guidelines:

- Always disconnect all external cables before lifting or moving the chassis.
- Ensure that your footing is solid, and balance the weight of the chassis between your feet.
- Lift the chassis slowly; never move suddenly or twist your body as you lift.
- Keep your back straight and lift with your legs, not your back. If you must bend down to lift the chassis, bend at the knees, not at the waist, to reduce the strain on your lower back muscles.

Rack-Mounting the Chassis

There are three rack-mount kits and one cable management kit available for both the Catalyst 4948E and the Catalyst 4948E-F switch chassis. Additionally, there is one optional inlet air duct kit that is available only for the Catalyst 4948E-F switch. [Table 3-1](#) lists the kits and describes their contents.

Table 3-1 Catalyst 4948E and Catalyst 4948E-F Chassis Rack-Mount and Cable Management Kits

Kit Part Number	Description
69-2037-xx	Standard rack-mount kit for both chassis. Kit includes brackets and screws. The kit ships with the chassis as part of the accessory kit. Installation instructions are located in this chapter.
WS-X4948E-19CNTR=	Center rack-mount kit for 19-inch racks. Kit includes brackets and screws. The kit is available as a separately orderable option. Installation instructions are contained in a separate installation note available on cisco.com .
WS-X4948E-23CNTR=	Center rack-mount kit for 23-inch racks. Available for both chassis. Kit includes brackets and screws. The kit is available as a separately orderable option. Installation instructions are contained in a separate installation note available on cisco.com .
69-1303-xx	Cable management bracket kit. Kit includes the cable management bracket and screws. The kit ships with both chassis. Installation instructions are located in this chapter.
Panduit Corp. model CDE2	Modular ToR switch inlet air duct kit. The kit includes a switch ducting enclosure, one switch support bracket, and installation hardware. The kit is an option, orderable from Panduit Corp. The kit is used only when installing the Catalyst 4948E-F switch chassis and only when installing the chassis in a hot isle and cold isle data center environment. Installation instructions for the kit are provided in a separate installation note supplied with the air duct kit.

The process for installing the Catalyst 4948E switch in a 19-inch rack is divided into the following topics:

- [Attaching the Rack-Mount Brackets to the Chassis, page 3-6](#)
- [Installing the Chassis in the Rack, page 3-7](#)
- [Installing the Cable Guide \(Optional\), page 3-8](#)

Attaching the Rack-Mount Brackets to the Chassis

Two rack-mount brackets are included as part of the rack-mount kit (69-2037-xx) supplied with both switch chassis. The rack-mount brackets can be installed either on the front sides of the chassis or on the rear sides of the chassis. The rack-mount brackets are intended for use in mounting the chassis in a standard 19-inch (48.3 cm). This rack-mount kit is not suitable for racks with obstructions (such as power strips) that could impair access to the switch.

**Note**

If you are installing the Catalyst 4948E-F switch chassis in a hot isle and cold isle data center environment and plan on using the optional modular ToR switch inlet duct kit (Panduit model CDE2), you must install the rack-mount brackets to the front of the chassis.

To install the rack-mount brackets on the front sides of the chassis, follow these steps:

-
- Step 1** Remove the two rack-mount brackets and eight M4 x 8 mm Phillips flat-head screws from the accessory kit.
- Step 2** Position one of the rack-mount brackets against one side of the chassis, and align the countersunk screw holes with the M4 holes in the chassis. (See [Figure 3-1](#).)

**Note**

In [Figure 3-1](#), the top view shows the rack-mount brackets being attached to the front of the chassis. The bottom view shows the rack-mount brackets being attached to the rear of the chassis.

- Step 3** Secure the rack-mount bracket to the chassis with four M4 x 8 mm Phillips flat-screws.
- Step 4** Repeat Steps 2 and 3 for the second rack-mount bracket on the opposite side of the chassis.

Figure 3-1 Installing the Rack-Mount Brackets

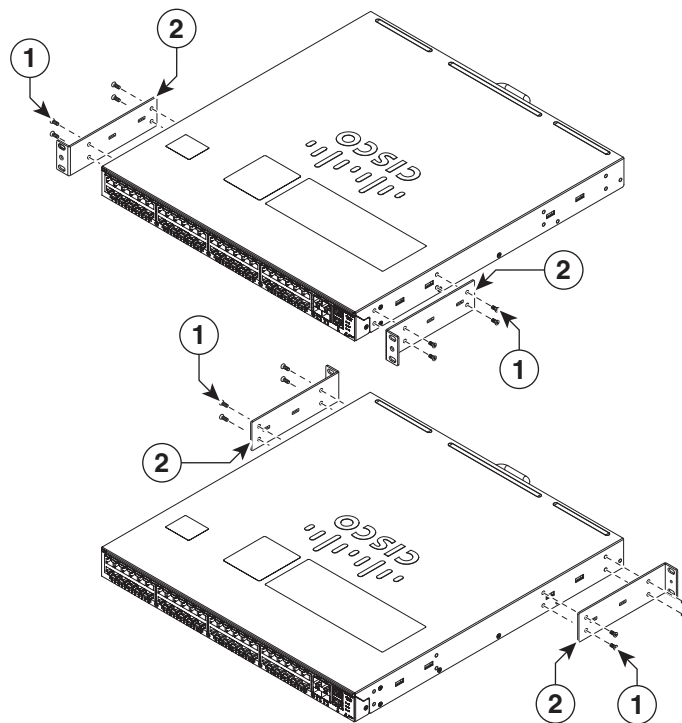

1	M4 screws (4 screws per bracket)	2	Rack-mount bracket
----------	----------------------------------	----------	--------------------

Installing the Chassis in the Rack

To install the chassis in the rack, follow these steps:

-
- Step 1** Have one person carefully lift and position the chassis in front of the rack.
- Step 2** Position the chassis in the rack until the rack-mount bracket ears are in contact with the rack.
-
-  **Tip** Use a tape measure or a level to ensure that the chassis is installed level in the rack.
-
- Step 3** Adjust the chassis up or down in the rack until two screw holes in each rack-mount bracket ear are aligned with corresponding mounting holes in the equipment rack post. Place a level on top of the chassis and verify that the chassis is not tilted in the equipment rack.
- Step 4** While one person holds the chassis in place, secure the chassis to the rack with the four 10-32 x 3/4-inch or the four 12-24 x 3/4-inch Phillips-head machine screws (two on each side) that are supplied in the accessory kit.

Note

Figure 3-2 (top view) shows how to install a chassis in a rack when the chassis has the rack-mount brackets attached at the front of the chassis. Figure 3-2 (bottom view) shows how to install a chassis in a rack when the chassis has the rack-mount brackets attached at the rear of the chassis.

Figure 3-2 Installing the Chassis in the Rack

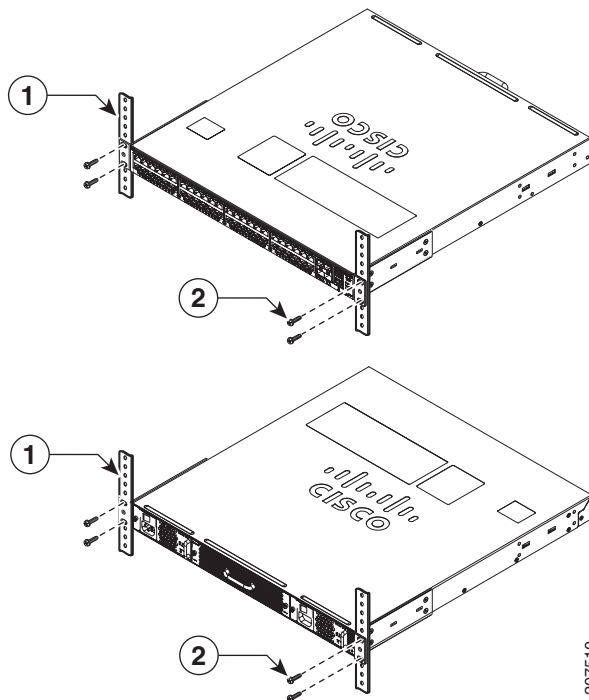

1	12-24 or 10-32 screws (2 per bracket)	2	Equipment rack post
----------	---------------------------------------	----------	---------------------

Installing the Cable Guide (Optional)

One cable guide is provided in the accessory kit. The cable guide attaches to the rack-mount bracket using a single M4 screw (a threaded M4 hole is provided in the rack-mount bracket). The cable guide is designed to be used when the rack-mount brackets are attached to the front of the chassis and can be attached to either the left side or the right side of the chassis.



Note

If the chassis is mounted to the rear posts of the equipment rack, the cable guide cannot be installed.

To install the cable guide, follow these steps:

- Step 1** Position the cable guide in front of either the left or right rack-mount bracket.
- Step 2** Attach the cable guide to either the left or right rack-mount bracket using the single M4 screw provided. (See [Figure 3-3](#).)

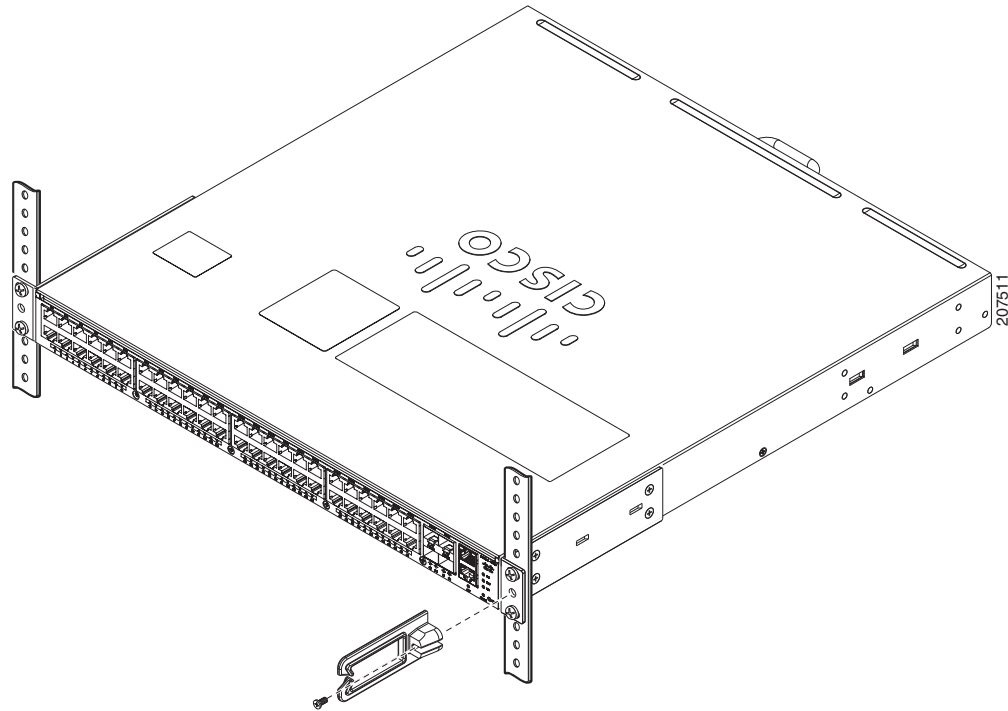
Figure 3-3 *Installing the Cable Guide*



Installing the Catalyst 4948E-F Switch Chassis with the Optional Panduit Air Duct Kit

If you are installing the Catalyst 4948E-F switch chassis in a data center that is configured as hot isle and cold isle, you might need to install the Panduit Air Duct kit, Model CDE2. The kit extends the air intake from the rear of the chassis to the front of the equipment rack allowing the system to draw in cool air from the cool isle. To install the air duct assembly, refer to the installation note that ships with the kit.

Installing the System Ground

The system (NEBS) ground provides additional grounding for EMI shielding requirements and is intended to satisfy the Telcordia Technologies NEBS requirements for supplemental bonding and grounding connections.

To connect the system ground, you need the following tools and materials:

- Ground lug—A two-hole standard 90-degree barrel lug. Supports up to 6 AWG wire.
- Ground lug screws—Two M4 x 8 mm pan-head screws.
- Ground wire—The system ground wire should be sized according to local and national installation requirements. Depending on the power supply and system, a 12 AWG to 6 AWG copper conductor is required for U.S. installations. We recommend that you use commercially available 6 AWG wire. The length of the system ground wire depends on the proximity of the switch to proper grounding facilities.
- No. 1 Phillips screwdriver.
- Wire-stripping tool to remove the insulation from the ground wire.
- Crimping tool to crimp the system ground wire to the ground lug.

**Note**

The grounding lug and the grounding lug screws are supplied as part of the accessory kit. The grounding wire and the tools are not supplied as part of the accessory kit.

To attach the system ground wire to the ground lug and attach the lug to the grounding pad, follow these steps:

- Step 1** If you are using insulated wire, use a wire-stripping tool to remove approximately 0.75 inch (19 mm) of the covering from the end of the ground wire. If you are using bare wire, go to Step 2.
- Step 2** Insert the stripped end of the ground wire into the open end of the ground lug.
- Step 3** Crimp the ground wire in the barrel of the ground lug. Verify that the ground wire is securely attached to the ground lug.
- Step 4** Remove the yellow label covering the chassis system ground pad on the back of the chassis. (See [Figure 3-4](#).)
- Step 5** Place the ground wire lug against the system ground pad, making sure that there is solid metal-to-metal contact.
- Step 6** Secure the ground lug to the chassis with the two M4 screws supplied in the accessory kit. (See [Figure 3-4](#).) Route the system ground wire ensuring that it does not interfere with other switch hardware or rack equipment.
- Step 7** Prepare the other end of the ground wire, and connect it to an appropriate earth ground point in your site to ensure adequate earth ground for the switch.

Figure 3-4 Installing the System Ground

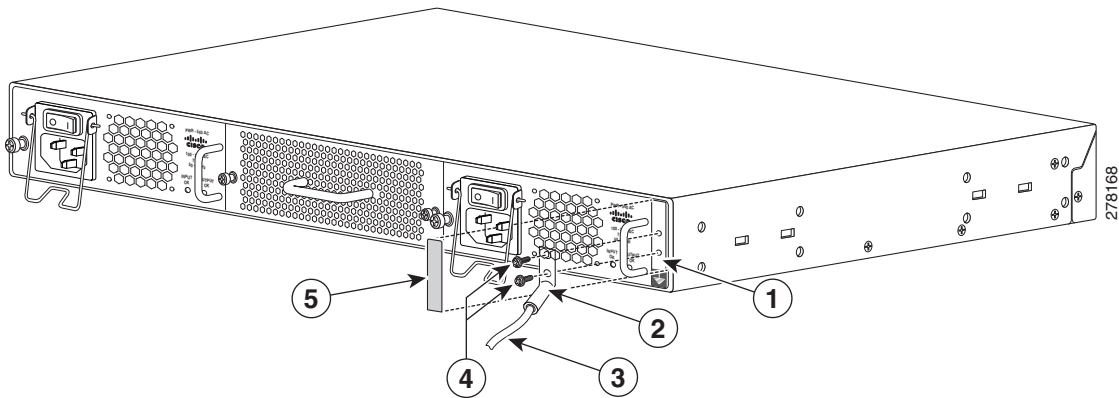

1	Chassis grounding pad	4	M4 screws (2X)
2	System ground lug	5	Adhesive label (yellow). Covers grounding pad.
3	System ground wire		

Connecting Power to the Switch

This section provides instructions on connecting source power to the chassis. Two procedures are provided:

- [Connecting AC Source Power to the Switch, page 3-12](#)
- [Connecting DC Source Power to the Switch, page 3-13](#)



Note

The Catalyst 4948E switch supports mixing AC-input and DC-input power supplies in the same chassis.

Connecting AC Source Power to the Switch

To connect source AC power to either a Catalyst 4948E or Catalyst 4948E-F switch, follow these steps:

Step 1 Verify that all of the site power and grounding requirements described in [Chapter 2, “Preparing for Installation”](#) have been met and the chassis is properly grounded as described in the [“System Grounding” section on page 2-7](#).

Step 2 Verify that the power supply is fully seated in the chassis power supply bay and that the captive installation screw on the power supply is tight. Verify that the AC power switch on the power supply is off.



Warning

The plug-socket combination must be accessible at all times, because it serves as the main disconnecting device. Statement 1019

Step 3 Remove the AC power cords from the accessory kit and verify that you have the correct ones for your locale. If you are unsure as to the type of AC power cord required for your location, refer to the [“300 W AC-Input Power Supply Power Cords” section on page A-8](#) for a list of the AC power cords supported by the AC-input power supplies and consult with your local electrician.

Step 4 Plug the AC power cord’s appliance connector (IEC60320/C15) into the power supply AC-in receptacle. [Figure 3-5](#) shows plug locations for both the PWR-C49E-300AC-R and the PWR-C49E-300AC-F power supplies.



Note

If you are using the optional Panduit Modular ToR Switch Inlet Duct kit (Model CDE2) with the Catalyst 4948E-F switch chassis, you need to thread the AC power cord through the air duct. Refer to the installation note supplied with the duct kit for instructions on how to do this.

Figure 3-5 Connecting Source AC to the AC-Input Power Supply

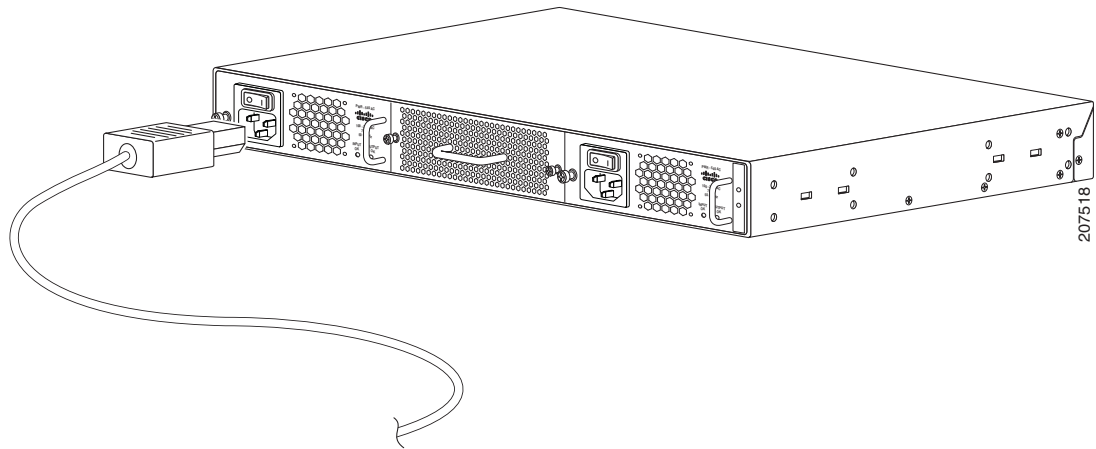

- Step 5** Connect the other end of the power cord to an AC-power input source. If two power supplies will be used to power the chassis, make sure that each AC-input power supply is plugged into its own dedicated circuit.



Note

If you have only one power supply installed in the chassis, you must cover the empty power supply bay with a blank power supply cover (Cisco p/n 800-25264-01). The blank power supply cover maintains EMI shielding and proper air flow through the chassis.

- Step 6** Do not turn on the AC-input power supply power on/off switch at this time. Continue the installation process by attaching the interface cables to the chassis ports.

Connecting DC Source Power to the Switch



Warning

Before performing any of the following procedures, ensure that power is removed from the DC circuit. Statement 1003



Warning

This unit is intended for installation in restricted access areas. A restricted access area can be accessed only through the use of a special tool, lock and key, or other means of security.

Statement 1017



Warning

This product requires short-circuit (overcurrent) protection, to be provided as part of the building installation. Install only in accordance with national and local wiring regulations. Statement 1045



Warning

Hazardous voltage or energy may be present on DC power terminals. Always replace cover when terminals are not in service. Be sure uninsulated conductors are not accessible when cover is in place. Statement 1075

To connect source DC power to the DC-input power supply installed in the Catalyst 4948E switch, follow these steps:

-
- Step 1** Verify that all of the site power and grounding requirements described in “[Power Requirements](#)” section on page 2-11 have been met and the chassis is properly grounded.
- Step 2** Verify that power is off to the DC circuit you are going to attach to the DC-input power supply. As an added precaution, place the appropriate safety flag and lockout devices at the source power circuit breaker, or place a piece of adhesive tape over the circuit breaker handle to prevent accidental power restoration while you are working on the circuit.
- Step 3** Connect the DC cables to the source DC circuit breaker.
- Step 4** Verify that the DC-input power supply is fully seated in the chassis power supply bay and that the captive installation screw on the power supply is tight.
- Step 5** Remove the snap-on plastic safety cover from the DC-input power supply terminal block.
- Step 6** Attach the appropriate size and type of lugs to the source DC cables.

Either insulated crimp-on spade lugs or insulated crimp-on ring connectors can be used on the source DC cables. They should be sized according to local and national installation requirements and electrical codes.



Note The wire should be sized according to local and national installation requirements and electrical codes. Use only copper wire.

- Step 7** Connect the source DC cable lugs to the power supply terminal block posts in this order (see [Figure 3-6](#)):
- Ground cable lug to the power supply ground terminal post.
 - Negative (–) source DC cable lug to the power supply negative (–) terminal post.
 - Positive (+) source DC cable lug to the power supply positive (+) terminal post.
- Step 8** After ensuring that all of the cable connections are secure, reinstall the terminal block cover.



Caution To prevent a short circuit or shock hazard after wiring the DC-input power supply, you must reinstall the terminal block cover.



Caution In a system with dual DC-input power supplies, connect each power supply to a separate power source. In case of a power source failure to one supply, the second power source should still be available.

- Step 9** Do not turn source DC power on at this time. Continue the installation process by attaching the interface cables to the chassis ports.

Figure 3-6 Connecting Source DC to the DC-Input Power Supply (PWR-C49-300DC)

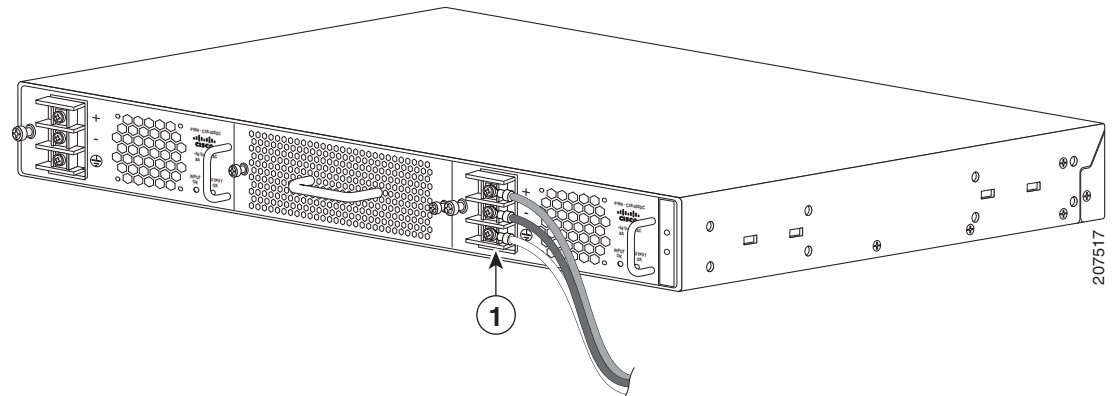

- | | | |
|----------|---|--|
| 1 | <p>Attach the source DC leads to the power supply terminal block in the following order:</p> <ul style="list-style-type: none"> • Ground • (-) negative • (+) positive | |
|----------|---|--|

Attaching the Interface Cables

This section covers attaching the interface cables to the chassis front panel connectors. The section is divided into the following topics:

[Connecting to the Downlink Ports, page 3-16](#)

[Installing Uplink Port Transceivers and Cables, page 3-16](#)

[Connecting to the Ethernet Management Port, page 3-20](#)

[Connecting to the Console Port, page 3-20](#)

Connecting to the Downlink Ports

Both chassis have 48 10/100/1000 ports. The ports configure themselves to operate at the speed of the attached devices. If the attached devices do not support autonegotiation, you can explicitly set the speed and duplex parameters.

To attach network cables to the downlink ports, follow these steps:

-
- Step 1** Connect the RJ-45 plug at one end of the network cable to the target device port.
- Step 2** Connect the RJ-45 plug at the other end of the network cable to a downlink port on the Catalyst 4948E chassis.
- Step 3** Repeat Steps 1 and 2 for the remaining downlink ports.
-

Installing Uplink Port Transceivers and Cables

The four uplink ports on the Catalyst 4948E support either 1000BASE-X SFP or 10GBASE SFP+ transceivers. SFP transceivers can have three types of latching devices to secure an SFP transceiver in a port socket:

- [Figure 3-7](#) shows an SFP transceiver with a Mylar tab latch.
- [Figure 3-8](#) shows an SFP transceiver with an actuator button latch.
- [Figure 3-9](#) shows an SFP transceiver that has a bail-clasp latch.

Determine which type of latch your SFP transceiver uses before following the installation and removal procedures.



Caution

Do not install or remove the SFP transceiver with fiber-optic cables attached to it. Doing so may damage cables, cable connectors, or the optical interfaces and may interfere with the SFP transceiver latching properly into its socket connector. Disconnect all cables before removing or installing an SFP transceiver.

Removing and installing an SFP transceiver can shorten its useful life. Do not remove and insert SFP transceivers more often than is absolutely necessary.



Caution

The SFP transceivers are static-sensitive devices. Always use an ESD wrist strap or similar individual grounding device when handling SFP transceivers.

Figure 3-7 SFP Transceiver with a Mylar Tab Latch

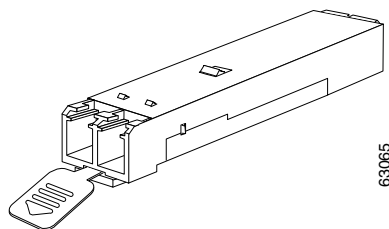
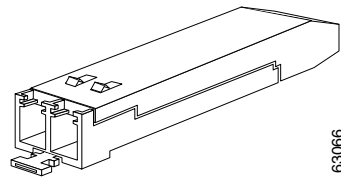
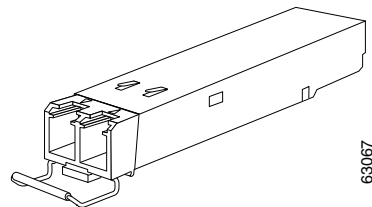

Figure 3-8 SFP Transceiver with an Actuator Button Latch**Figure 3-9 SFP Transceiver with a Bail-Clasp Latch**

To install either an SFP or SFP+ transceiver, follow these steps:



-
- Step 1** Attach an ESD-preventive wrist strap to your wrist and to the ESD ground connector or a bare metal surface on your chassis.
- Step 2** Remove the SFP transceiver from its protective packaging.
-  **Note** Do not remove the optical bore dust plugs until directed to do so later in the procedure.
-
- Step 3** Check the label on the SFP transceiver body to verify that you have the correct model for your network.
- Step 4** Find the send (TX) and receive (RX) markings that identify the top side of the SFP transceiver.
-  **Note** On some SFP transceivers, the TX and RX marking might be replaced by arrowheads pointing from the SFP transceiver connector (transmit direction or TX) and toward the connector (receive direction or RX).
-
- Step 5** Position the SFP transceiver in front of the socket opening.
-  **Note** Different Cisco devices have different SFP socket configurations. Your Cisco device could have either a latch-up or a latch-down orientation. Ensure that you are installing the SFP transceiver in the correct orientation for your Cisco device.
-
- Step 6** Holding it as shown in [Figure 3-10](#), insert the SFP into the socket until you feel the connector latch into place.

Figure 3-10 Inserting an SFP Transceiver into a Socket



Step 7 Press the SFP transceiver into the slot firmly with your thumb as shown in [Figure 3-11](#).

Figure 3-11 Latching the SFP Transceiver

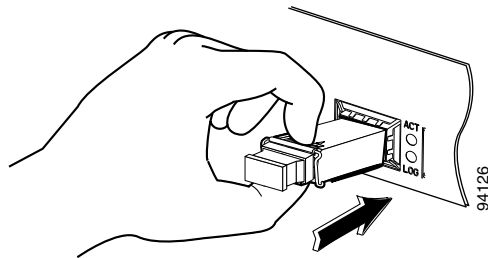
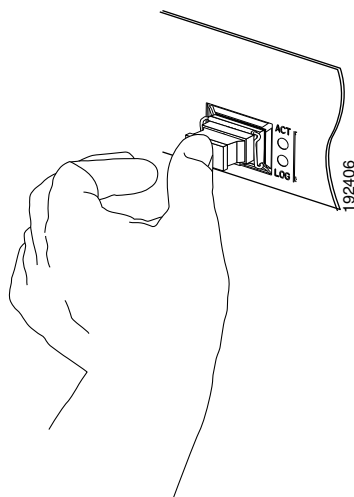

Step 8 To verify that the SFP transceiver is seated and latched properly:

- a. Grasp the SFP transceiver as shown in [Figure 3-12](#) and try to remove it without releasing the latch.
- b. If the SFP transceiver cannot be removed, it is installed and seated properly. If the SFP transceiver can be removed, reinsert it and press harder with your thumb, repeating if necessary until it is latched securely into the socket.

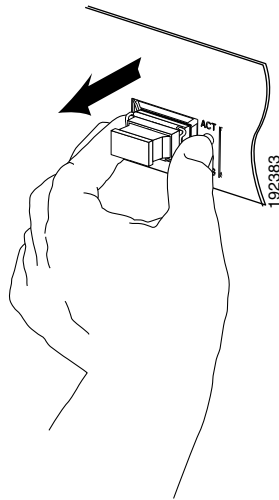
Figure 3-12 Verifying the SFP Transceiver Installation**Note**

For an optical SFP transceiver, before removing the dust plugs and making any optical connections, observe the following guidelines:

- Always keep the protective dust plugs on the unplugged fiber-optic cable connectors and the transceiver optical bores until you are ready to make a connection.
- Always inspect and clean the LC connector end-faces just before making any connections. See the Tip on this page for a pointer to a fiber-optic inspection and cleaning white paper.
- Always grasp the LC connector housing to plug or unplug a fiber-optic cable.

Step 9 Remove the dust plugs from the network interface cable LC connectors. Save the dust plugs for future use.

Step 10 Inspect and clean the LC connector's fiber-optic end-faces.

**Tip**

For complete information on inspecting and cleaning fiber-optic connections, see the white-paper document at this URL:

http://www.cisco.com/en/US/tech/tk482/tk876/technologies_white_paper09186a0080254eba.shtml

Step 11 Remove the dust plugs from the SFP transceiver optical bores.

Step 12 Immediately attach the network interface cable LC connector to the SFP transceiver.

Step 13 To connect 1000BASE-T SFP transceivers to a copper network, follow these substeps:



Caution

To comply with GR-1089 intrabuilding lightning immunity requirements, you must use grounded, shielded, twisted-pair Category 5 cabling.

- a. Insert the Category 5 network cable RJ-45 connector into the SFP transceiver RJ-45 connector.



Note

When connecting to a 1000BASE-T-compatible server, workstation, or router, use four twisted-pair, straight-through Category 5 cabling for the SFP transceiver port. When connecting to a 1000BASE-T-compatible switch or repeater, use four twisted-pair, crossover Category 5 cabling.

- b. Insert the other end of the network cable into an RJ-45 connector on a 1000BASE-T-compatible target device.

Connecting to the Ethernet Management Port

Both chassis provide a Ethernet Management port that can be used to manage the switch through an Ethernet network. This port can also be used to download software to the switch or transfer files to remote servers for analysis or backup storage.

The typical connection to the Management Ethernet port uses an Ethernet cable with RJ-45 connectors at each end. The other end of the cable typically connects to an Ethernet switch, hub, or router that provides connectivity between the multishelf system and networks from which system management is desired.

To attach a cable to the Ethernet management port, follow these steps:

Step 1 Connect the RJ-45 plug at one end of the network cable to the target device port.

Step 2 Connect the RJ-45 plug at the other end of the network cable to a Ethernet Management port on the Catalyst 4948E chassis.

Connecting to the Console Port

You must use the console port to perform the initial configuration. To connect the switch console port to a PC, use an RJ-45-to-DB-9 adapter cable (optional).

To connect the PC or terminal to the Catalyst 4948E switch console port, follow these steps:

Step 1 Using an RJ-45-to-DB-9 adapter cable, insert the RJ-45 connector into the console port that is located on the front of the switch.

Step 2 Attach the DB-9 female DTE of the adapter cable to a PC serial port, or attach an appropriate adapter to the terminal.

Powering Up the Switch

This section provides a quick power-up procedure for a switch. The section is divided into the following topics:

- [Starting the Terminal-Emulation Software, page 3-21](#)
- [Powering Up the Switch, page 3-21](#)

Starting the Terminal-Emulation Software

Before you power-up the switch, start the terminal-emulation session so that you can see the output display from the power-on self-test (POST).

The terminal-emulation software, which is frequently a PC application such as Hyperterminal or ProcommPlus, makes communication between the switch and your PC or terminal possible.

To start the terminal-emulation software, follow these steps:

-
- Step 1** Start the terminal-emulation program if you are using a PC or terminal.
 - Step 2** Start a terminal-emulation session.
 - Step 3** Configure the baud rate and character format of the PC or terminal to match these console port default characteristics:
 - 9600 baud
 - 8 data bits
 - 1 stop bit
 - No parity
 - None (flow control)
-

Powering Up the Switch

If your chassis has AC-input power supplies installed, follow these steps to power up the chassis:

-
- Step 1** Switch the power supply power switches to the ON position.
 - Step 2** Verify power supplies are operating correctly by looking at the INPUT OK and the OUTPUT OK LEDs located on the power supply faceplate. The LEDs should be green when the power supply and the power supply fan are functioning normally.

Also verify that the front panel PS1 LED is lit green. If the chassis is equipped with a second (redundant) power supply, verify that the front panel PS2 LED is also lit green. If the LEDs are not green, refer to the “[300 W AC-Input Power Supply \(PWR-C49E-300AC-R\)](#)” section on page A-1 or “[300 W AC-Input Power Supply \(PWR-C49E-300AC-F\)](#)” section on page A-5 for additional LED descriptions.
-

If your chassis has DC-input power supplies installed, follow these steps to power up the chassis:

-
- Step 1** Verify that the terminal block cover is installed on the power supply correctly and that no bare wires are exposed.
- Step 2** Remove any safety flag and lockout devices or any tape from the source DC circuit breaker switch handle, and restore source DC power by moving the circuit breaker switch handle to the on (I) position.



Note The DC-input power supply does not have an on/off switch. Restoring source DC power will energize the Catalyst 4948E DC-input power supply and power up the chassis.

- Step 3** Verify power supplies are operating correctly by looking at the INPUT OK and the OUTPUT OK LEDs located on the power supply faceplate. The LEDs should be green when the power supply and the power supply fan are functioning normally.
- Step 4** Also verify that the front panel PS1 LED is lit green. If the chassis is equipped with a second (redundant) power supply, verify that the front panel PS2 LED is also lit green. If the LEDs are not green, refer to the “[300 W DC-Input Power Supply \(PWR-C49-300DC\)](#)” section on page A-12 for LED descriptions.
-

As the switch powers on, it begins the POST, which are a series of tests that run automatically to ensure that the switch functions properly. The POST lasts approximately 1 minute. After the POST is complete, the SYSTEM LED should be green. If the switch fails the POST, the SYSTEM LED turns amber.

The port status LEDs on the switch also cycle through several colors during power up.

- The LED turns amber while the STP feature discovers the network topology and searches for loops. This process takes about 30 seconds, and then the LED turns green.
- The LED turns green when the chassis port and the target device have an established link.
- If the LED is off, the target device might not be turned on, there might be a cable problem, or there might be a problem with the target device.



Note The POST failures are usually fatal. Call Cisco Systems if your switch does not pass the POST.

For information on configuring the Catalyst 4948E or the Catalyst 4948E-F switch, refer to the appropriate software configuration guide at:

http://www.cisco.com/en/US/products/ps6021/products_installation_and_configuration_guides_list.html



CHAPTER 4

Removal and Replacement Procedures

This chapter describes how to perform the following removal and replacement procedures for the Catalyst 4948E and the Catalyst 4948E-F switch field-replaceable units (FRUs) and contains these sections:

- [Removing and Installing the DC-Input Power Supply, page 4-2](#)
- [Removing and Installing the AC-Input Power Supply, page 4-8](#)
- [Removing and Installing the Fan Tray, page 4-10](#)



Warning

Only trained and qualified personnel should be allowed to install, replace, or service this equipment.
Statement 1030



Tip

For additional information about the Cisco Catalyst 4948E switch (including configuration examples and troubleshooting information), see the documents listed on this page:

http://www.cisco.com/en/US/products/ps6021/tsd_products_support_series_home.html

The chassis FRUs and their associated part numbers are listed in [Table 4-1](#).

Table 4-1 Catalyst 4948E and Catalyst 4948E-F Chassis FRUs

FRU	Catalyst 4948E	Catalyst 4948E-F
Fan tray	WS-X4993	WS-X4993-F
Power supply	AC-input—PWR-C49E-300AC-R DC-input—PWR-C49-300DC	AC-input—PWR-C49E-300AC-F
Blank power supply cover	WS-X4994	WS-X4994-F

Removing and Installing the DC-Input Power Supply

This section describes how to remove and install the DC-input power supplies (PWR-C49-300DC) in the Catalyst 4948E switch chassis and contains these subsections:

- [Required Tools, page 4-2](#)
- [Removing the DC-Input Power Supply, page 4-2](#)
- [Installing the DC-Input Power Supply, page 4-5](#)



Note

The Catalyst 4948E-F chassis does not support the PWR-C49-300DC DC-input power supply.



Caution

Installation of the equipment must comply with local and national electrical codes.



Caution

Ensure that the DC return remains isolated from the system frame and the chassis (DC-I).



Note

You can use the grounding lug to attach a wrist strap for ESD protection during servicing.



Warning

Before performing any of the following procedures, ensure that power is removed from the DC circuits. To ensure that all power is removed, locate the circuit breakers or fuses on the DC power lines that service the DC circuits. Turn OFF the DC power line circuit breakers and remove the DC power line fuses. Statement 322



Warning

When installing or replacing the unit, the ground connection must always be made first and disconnected last. Statement 1046

Required Tools

To perform this procedure, you will need a Number 2 Phillips screwdriver.

Removing the DC-Input Power Supply

To remove a DC-input power supply, follow these steps:

-
- Step 1** Set the power switch/circuit breaker to the off (0) position on the circuit that feeds the power supply that you are removing.
- As an added precaution, place the appropriate safety flag and lockout devices at the source power circuit breaker, or place a piece of adhesive tape over the circuit breaker handle to prevent accidental power restoration while you are working on the circuit.
- Step 2** Remove the clear plastic terminal block cover from the power supply terminal block.

Step 3 Disconnect the DC-input cables from the power supply terminal block in this order (See [Figure 4-1](#), top view):

1. Positive (+) source DC cable from the positive (+) terminal
2. Negative (-) source DC cable from the negative (-) terminal
3. Ground cable from the ground terminal

Step 4 Loosen the captive installation screw on the power supply.

Step 5 Grasp the power supply handle with one hand, and slide the power supply halfway out of the chassis. Place your other hand underneath the power supply, as shown in [Figure 4-1](#) (bottom view), and slide the power supply completely out of the chassis. Set the power supply aside.



Note The DC power supply is equipped with an EMI gasket on the top and bottom (on the front edge) of the power supply. When sliding the power supply into or out of the power supply bay, be careful not to damage the EMI gaskets.

Step 6 If the power supply bay is to remain empty, install a blank faceplate (WS-X4994) over the opening, and secure it in place with the captive installation screw.

Removing and Installing the DC-Input Power Supply

Figure 4-1 Removing the DC-Input Power Supply

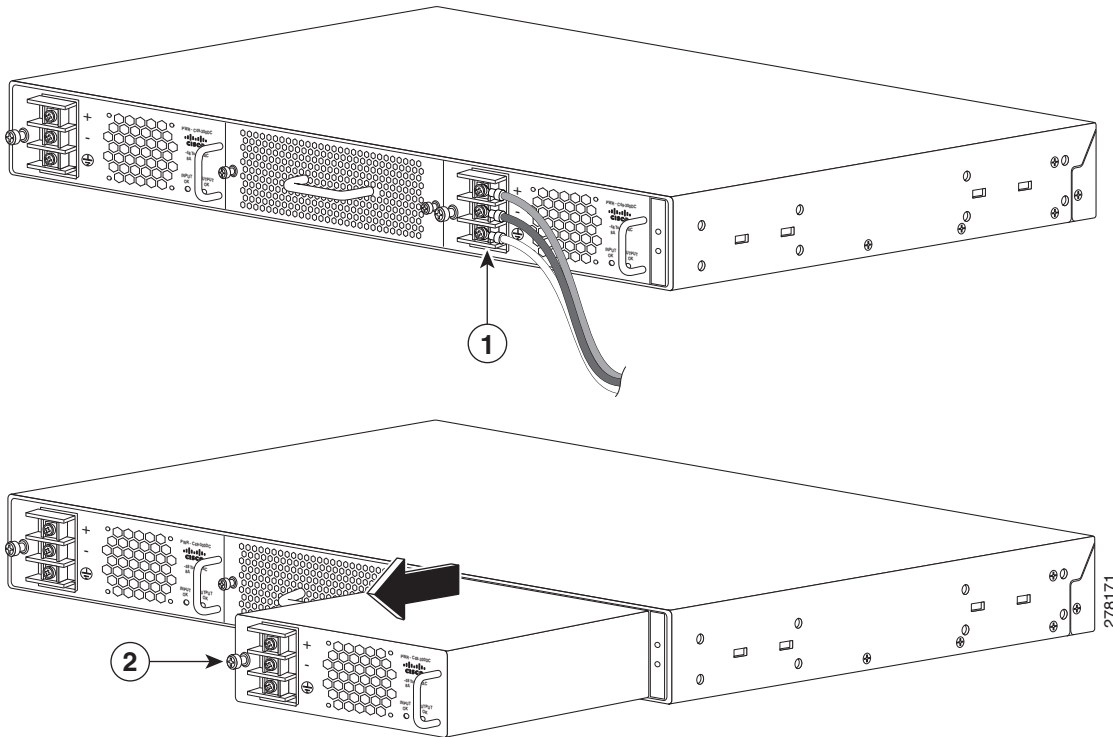

<p>1 Detach the power leads from the terminal block in the following order:</p> <ul style="list-style-type: none"> • (+) positive • (-) negative • Ground 	<p>2 Loosen captive installation screw</p>
---	---

Installing the DC-Input Power Supply

**Warning**

Before performing any of the following procedures, ensure that power is removed from the DC circuits. To ensure that all power is removed, locate the circuit breakers or fuses on the DC power lines that service the DC circuits. Turn OFF the DC power line circuit breakers and remove the DC power line fuses. Statement 322

**Warning**

When installing or replacing the unit, the ground connection must always be made first and disconnected last. Statement 1046

To install a DC-input power supply in the Catalyst 4948E switch, follow these steps:

-
- Step 1** Ensure that the system (earth) ground chassis connection has been made.
- Step 2** Verify that power is off to the DC circuit that feeds the power supply that you are installing.
- As an added precaution, place the appropriate safety flag and lockout devices at the source power circuit breaker, or place a piece of adhesive tape over the circuit breaker handle to prevent accidental power restoration while you are working on the circuit.
- Step 3** Remove the new DC-input power supply from its protective packaging.
- Step 4** Grasp the power supply handle with one hand, and place your other hand underneath the power supply. Slide the power supply into the power supply bay until the power supply makes contact with the chassis power connector. (See [Figure 4-2](#).) Press firmly on the power supply faceplate to fully seat the power supply in the bay.

**Note**

The DC power supply is equipped with an EMI gasket on the top, bottom, and sides (on the front edge) of the power supply. When sliding the power supply into the power supply bay, be careful not to damage the EMI gaskets.

-
- Step 5** Tighten the power supply captive installation screw.
- Step 6** Remove the plastic cover from the terminal block.
- Step 7** Attach the appropriate lugs to the source DC wires.

Either insulated crimp-on spade lugs or insulated crimp-on ring connectors can be used on the source DC cables. They should be sized according to local and national installation requirements and electrical codes.

**Note**

The wire should be sized according to local and national installation requirements and electrical codes. Use only copper wire.

Step 8 Connect the DC-input wires to the terminal block in this order:

1. Ground cable to the ground connector on the terminal block
2. Negative (–) source DC cable to the negative (–) connector on the terminal block
3. Positive (+) source DC cable to the positive (+) connector on the terminal block

Step 9 After ensuring that all wire connections are secure, reinstall the plastic terminal block cover.

**Caution**

To prevent a short circuit or shock hazard after wiring the DC-input power supply, you must reinstall the terminal block cover.

**Note**

In a system with dual power supplies, connect each power supply to a separate power source. In case of a power source failure to one supply, the second power source should still be available.

Step 10 Remove any safety flag and lockout devices or any tape from the circuit breaker switch handle, and restore power by moving the circuit breaker switch handle to the on (I) position.

Step 11 Verify the power supply operation by ensuring that the INPUT OK and the OUTPUT OK LEDs on the power supply front panel are both green.

Figure 4-2 Installing the DC-Input Power Supply

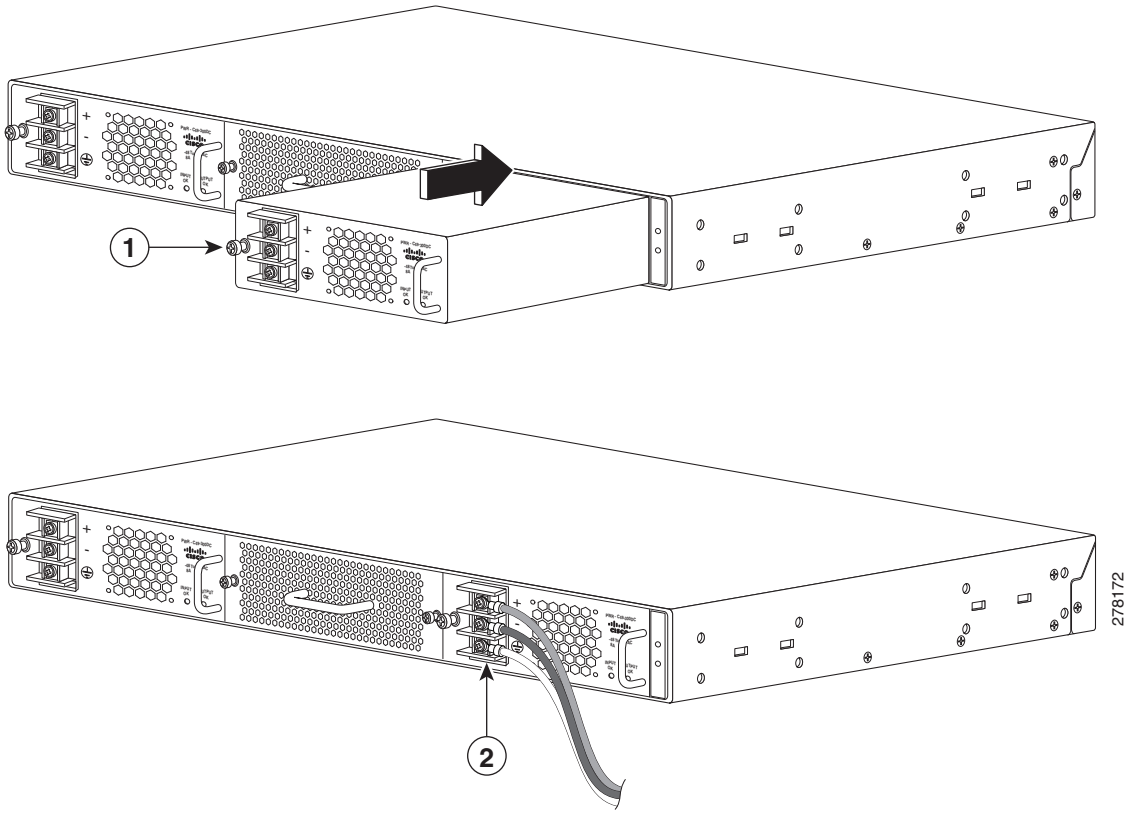

278172

<p>1 Secure the power supply in the chassis with the captive installation screw.</p>	<p>2 Attach the source DC leads to the terminal block in the following order:</p> <ul style="list-style-type: none"> • Ground • (-) negative • (+) positive
---	---

Removing and Installing the AC-Input Power Supply

This section describes how to remove and install the AC-input power supply (PWR-C49E-300AC-R) in the Catalyst 4948E switch chassis or the AC-input power supply (PWR-C49E-300AC-F) in the Catalyst 4948E-F switch chassis and contains the following subsections:

- [Required Tools, page 4-8](#)
- [Removing the AC-Input Power Supply, page 4-8](#)
- [Installing the AC-Input Power Supply, page 4-9](#)



Note

The two models of AC-input power supplies are not interchangeable between the two chassis. They are keyed to prevent accidental insertion into the wrong chassis.

Required Tools

You might need a Number 2 Phillips screwdriver to loosen or tighten the captive installation screw.

Removing the AC-Input Power Supply



Note

If you have a Catalyst 4948E-F switch chassis and you have also installed the optional Panduit ToR Switch Inlet Duct (model CDE2) to extend the chassis's air intake, you do not need to remove the air duct or the switch chassis in order to remove and replace the AC-input power supply. There is adequate working space within the air duct to perform the removal and replacement steps.

To remove the AC-input power supply from the chassis, follow these steps:

- Step 1** Set the power switch to the off (0) position on the power supply that you are removing.
- Step 2** Disconnect the AC power cord from source AC and from the AC-in connector on the power supply. Set the power cord aside.
- Step 3** Loosen the captive installation screw on the power supply.
- Step 4** Grasp the power supply handle with one hand, and slide the power supply halfway out of the chassis. Place your other hand underneath the power supply and slide the power supply completely out of the chassis. (See [Figure 4-3](#).) Set the power supply aside.



Note

The AC power supply is equipped with an EMI gasket on the top, bottom, and sides (on the front edge) of the power supply. When sliding the power supply into or out of the power supply bay, be careful not to damage the EMI gaskets.

- Step 5** If the power supply bay is to remain empty, install a blank faceplate (WS-X4994= for the Catalyst 4948E or WS-X4994-F= for the Catalyst 4948E-F) over the opening, and secure it in place with the captive installation screw.

Figure 4-3 Removing and Installing an AC-Input Power Supply

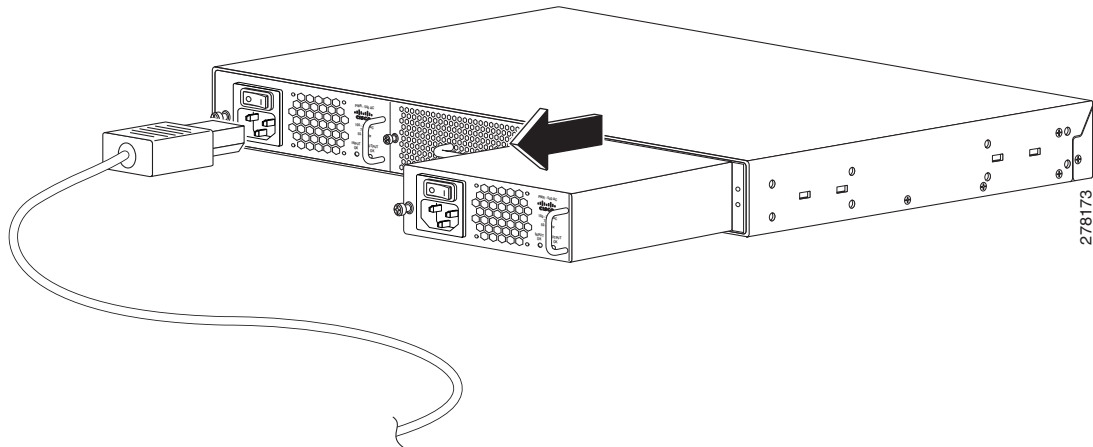

Installing the AC-Input Power Supply



Note

If you have a Catalyst 4948E-F switch chassis and you have also installed the optional Panduit ToR Switch Inlet Duct (model CDE2) to extend the chassis's air intake, you do not need to remove the air duct or the switch chassis in order to remove and replace the AC-input power supply. There is adequate working space within the air duct to perform the removal and replacement steps.

To install an AC-input power supply in the chassis, follow these steps:

- Step 1** Remove the new AC-input power supply from its protective packaging and set the packaging aside.
- Step 2** Loosen the two captive installation screws and remove the blank faceplate (WS-X4994= for the Catalyst 4948E or WS-X4994-F= for the Catalyst 4948E-F) covering the empty power supply bay opening. Save the blank faceplate for possible future use.
- Step 3** Verify that the power switch is in the off (0) position on the power supply that you are installing.



Note

If the power supply is connected to source AC with the power on/off switch in the on position, the two LEDs on the power supply faceplate will be lit red. To clear this condition, cycle the power on/off switch off, then on. The LEDs should then be lit green.

- Step 4** Grasp the power supply handle with one hand, and place your other hand underneath the power supply. Slide the power supply into the power supply bay. Make sure that the power supply is fully seated in the power supply bay.



Note

The AC power supply is equipped with an EMI gasket on the top and the bottom front edge of the power supply. When sliding the power supply into the power supply bay, be careful not to damage the EMI gaskets.

- Step 5** Tighten the power supply captive installation screw.
- Step 6** Plug the AC power cord appliance connector (C15 or C13 connector) into the AC-in receptacle on the power supply.
- Step 7** Plug the other end of the AC power cord into the source AC outlet.
- Step 8** Switch the power supply on/off switch to on.
- Verify the power supply operation by ensuring that the corresponding power supply LED (PS1 or PS2) on the chassis front panel is lit green. Also check the LEDs on the power supply front panel. Both LEDs (INPUT OK and OUTPUT OK) should be lit green.
- As an added check, verify that you can hear the power supply fan operating.
-

Removing and Installing the Fan Tray

This section describes how to remove and install the system fan tray (WS-X4993=) in the Catalyst 4948E switch chassis and contains these subsections:

- [Required Tools, page 4-10](#)
- [Removing the Fan Tray, page 4-10](#)
- [Installing the Fan Tray, page 4-11](#)

Required Tools

You might need a flat-blade or Number 2 Phillips screwdriver to loosen or tighten the captive installation screw on the fan tray.

Removing the Fan Tray

The system fan tray (WS-X4993=) can be removed and replaced while the system is operating without presenting an electrical hazard to the user or damage to the system. A 30-second window is provided for you to remove the defective fan tray and install the replacement tray. If you exceed 30 seconds, the system starts to overheat and automatically shuts down.



Note

If you have a Catalyst 4948E-F switch chassis and you have also installed the optional Panduit ToR Switch Inlet Duct (model CDE2) to extend the chassis's air intake, you do not need to remove the air duct or the switch chassis in order to remove and replace the fan tray. There is adequate working space within the air duct to perform the removal and replacement steps.



Warning

When removing the fan tray, keep your hands and fingers away from the spinning fan blades. Let the fan blades completely stop before you remove the fan tray. Statement 258

To remove the installed fan assembly, follow these steps:

-
- Step 1** Remove the replacement fan tray from its shipping packaging and place it near the chassis that you are working on.
 - Step 2** Loosen the two captive installation screws on the installed fan tray.
 - Step 3** Grasp the fan assembly handle, and pull it outward; gently move the fan tray from side to side, if necessary, to unseat the fan tray power connector from the chassis connector. (See [Figure 4-4](#).)
 - Step 4** Place your free hand under the fan tray to support it. Pull the fan assembly clear of the chassis, and set it aside. (See [Figure 4-4](#).)

Figure 4-4 Removing and Installing the Fan Tray

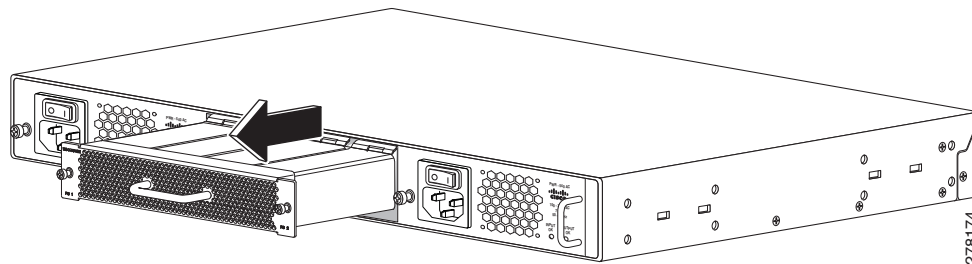

Installing the Fan Tray

**Note**

You have 30 seconds to install the replacement fan tray before the system automatically shuts down.

To install the new fan tray, follow these steps:

-
- Step 1** Position the replacement fan tray in front of the fan tray bay at the rear of the chassis. (See [Figure 4-4](#).)
 - Step 2** Slide the fan tray into the fan tray bay until the power connector seats in the chassis fan connector and the captive installation screws make contact with the chassis. The fans should immediately power up.
 - Step 3** Tighten the two fan tray captive installation screws to secure the fan tray in the chassis.
 - Step 4** Verify that the FAN LED on the chassis front panel is lit green.
-



APPENDIX **A**

Power Supply Specifications

This appendix provides the specifications for the AC-input and DC-input power supplies supported on the Catalyst 4948E switch.



Tip

For additional information about the Cisco Catalyst 4948E and the Catalyst 4948E-F switches (including configuration examples and troubleshooting information), see the documents listed on this page:

http://www.cisco.com/en/US/products/ps6021/tsd_products_support_series_home.html

300 W AC-Input Power Supply (PWR-C49E-300AC-R)

The PWR-C49E-300AC-R 300 W AC-input power supply can be installed only in the Catalyst 4948E switch chassis. This power supply is not supported on the Catalyst 4948E-F switch. [Figure A-1](#) shows the 300 W AC-input power supply with the major features identified.

Figure A-1 AC-Input Power Supply (PWR-C49E-300AC-R) Features

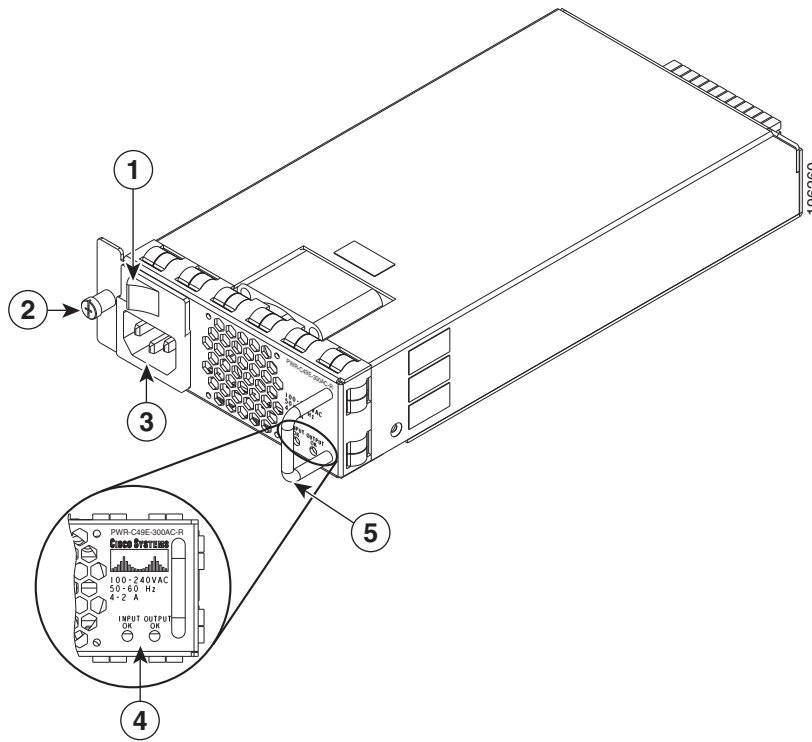

1	AC power switch	4	Power supply LEDs
2	Captive installation screw	5	Power supply handle
3	AC power cord receptacle		

Table A-1 lists the specifications for the 300 W AC-input power supply (PWR-C49E-300AC-R).

Table A-1 300 W AC-Input Power Supply Specifications

Item	Specification
AC-input type	<ul style="list-style-type: none"> • Autoranging input with power factor correction (PFC). • Power factor correction is a standard feature. PFC reduces the reactive component in the source AC current allowing higher power factors and lower harmonic current components.
AC-input voltage	<ul style="list-style-type: none"> • Low-line (120 VAC nominal)—85 VAC (min) to 132 VAC (max) • High-line (230 VAC nominal)—170 VAC (min) to 264 VAC (max)
AC-input current	<ul style="list-style-type: none"> • 4 A @ 100 VAC (maximum) • 2 A @ 240 VAC (maximum)
AC-input frequency	47 to 63 Hz
Branch circuit requirements	<p>Each chassis power supply should have its own dedicated, fused-branch circuit:</p> <ul style="list-style-type: none"> • For North America—15 A • For International—Circuits sized to local and national codes • All AC power supply inputs are fully isolated. <ul style="list-style-type: none"> – Source AC can be out of phase between multiple power supplies in the same chassis, which means that PS1 can be operating from phase A and PS2 can be operating from phase B. – For high-line operation, the power supply operates with the line conductor wired to a source AC phase and the neutral conductor wired either to neutral or to another source AC phase as long as the net input voltage is in the range of 170 to 264 VAC.
Power supply output	25 A @+12 VDC
Output holdup time	20 ms minimum
kVA rating ¹	0.375 kVA
Power supply fan	<ul style="list-style-type: none"> • One temperature-controlled, variable-speed fan • Airflow direction—Back to front • The power supply fan has four speed settings. The speed settings are dependent on the air temperature detected by the inlet air temperature sensor mounted in the chassis. See Table A-2 for inlet temperature ranges and corresponding fan speeds.

Table A-1 300 W AC-Input Power Supply Specifications (continued)

Item	Specification
Power supply LEDs INPUT OK OUTPUT OK	<ul style="list-style-type: none"> • Green—The INPUT OK LED is lit green when the power supply has detected that the source AC voltage is within limits. The input voltage is $\geq 82 \text{ VAC} \pm 3 \text{ VAC}$. • Red—The INPUT OK LED is red when either of the following two situations occurs: <ul style="list-style-type: none"> - In chassis that are equipped with dual power supplies, and both are powered on, either INPUT OK LED is lit red if its source AC voltage falls below 73 VAC ($\pm 3 \text{ VAC}$). - In chassis that are equipped with dual power supplies and one power supply is powered on and the other power supply is powered off, the INPUT OK LED is lit red, rather than unlit, on the power supply that is turned off. • Off—In chassis that are equipped with a single power supply, the INPUT OK LED is off when source AC voltage falls below 73 VAC ($\pm 3 \text{ VAC}$), is not present with the power on/off switch turned on, or the power supply is turned off. • Green—The 12 VDC output is within margins (11.30 VDC < output voltage < 12.85 VDC). • Red—The OUTPUT OK LED is red when any of the following three situations occurs: <ul style="list-style-type: none"> - In chassis that are equipped with a single power supply, the 12 VDC output is out of tolerance (< 11.30 VDC or > 12.85 VDC). - In chassis that are equipped with dual power supplies and one power supply is powered on and the other power supply is powered off, the OUTPUT OK LED is lit red, rather than unlit, on the power supply that is turned off. - The OUTPUT OK LED is also lit red when a power supply fan failure is detected. A fan failure is triggered when the fan rotation drops below 4150 RPM \pm 150 RPM. • Off—In chassis that are equipped with a single power supply, the OUTPUT OK LED is off when the power supply is turned off.
Weight	2 lb (0.9 kg)

1. The kVA rating listed for the power supply should be used as the sizing criteria for both UPS outputs as well as standard circuits and transformers to power a switch.

Table A-2 PWR-C49E-300AC-R Power Supply Inlet Temperature Versus Fan Speed

Fan Speed Level	Inlet Temperature (T) ($\pm 2^{\circ}\text{C}$)	Fan Speed (RPM) ($\pm 100\text{RPM}$)
L1	$-5^{\circ}\text{C} < T \leq 35^{\circ}\text{C}$	8900
L2	$35^{\circ}\text{C} < T \leq 42^{\circ}\text{C}$	9800
L3	$42^{\circ}\text{C} < T \leq 50^{\circ}\text{C}$	11100
L4	$T > 50^{\circ}\text{C}$	12700

300 W AC-Input Power Supply (PWR-C49E-300AC-F)

The PWR-C49E-300AC-F 300 W AC-input power supply can be installed only in the Catalyst 4948E-F switch chassis. This power supply is not supported on the Catalyst 4948E switch. Figure A-2 shows the 300 W AC-input power supply with the major features identified.

Figure A-2 AC-Input Power Supply (PWR-C49E-300AC-F) Features

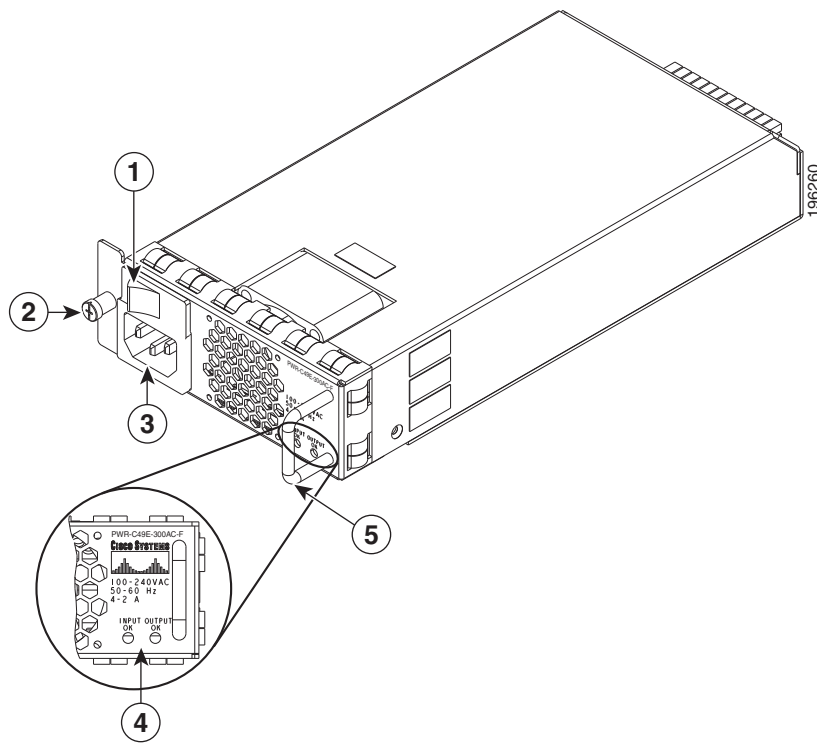

1	AC power switch	4	Power supply LEDs
2	Captive installation screw	5	Power supply handle
3	AC power cord receptacle		

Table A-1 lists the specifications for the 300 W AC-input power supply (PWR-C49E-300AC-F).

Table A-3 300 W AC-Input Power Supply (PWR-C49E-300AC-F) Specifications

Item	Specification
AC-input type	<ul style="list-style-type: none"> • Autoranging input with power factor correction (PFC). • Power factor correction is a standard feature. PFC reduces the reactive component in the source AC current allowing higher power factors and lower harmonic current components.
AC-input voltage	<ul style="list-style-type: none"> • Low-line (120 VAC nominal)—85 VAC (min) to 132 VAC (max) • High-line (230 VAC nominal)—170 VAC (min) to 264 VAC (max)
AC-input current	<ul style="list-style-type: none"> • 4 A @ 100 VAC (maximum) • 2 A @ 240 VAC (maximum)
AC-input frequency	47 to 63 Hz
Branch circuit requirements	<p>Each chassis power supply should have its own dedicated, fused-branch circuit:</p> <ul style="list-style-type: none"> • For North America—15 A • For International—Circuits sized to local and national codes • All AC power supply inputs are fully isolated. <ul style="list-style-type: none"> – Source AC can be out of phase between multiple power supplies in the same chassis, which means that PS1 can be operating from phase A and PS2 can be operating from phase B. – For high-line operation, the power supply operates with the line conductor wired to a source AC phase and the neutral conductor wired either to neutral or to another source AC phase as long as the net input voltage is in the range of 170 to 264 VAC.
Power supply output	25 A @ +12 VDC
Output holdup time	20 ms minimum
kVA rating ¹	0.4 kVA
Power supply fan	<ul style="list-style-type: none"> • One temperature-controlled, variable-speed fan • Airflow direction—Front to back • The power supply fan has four speed settings. The speed settings are dependent on the air temperature detected by the inlet air temperature sensor mounted in the chassis. See Table A-4 for inlet temperature ranges and corresponding fan speeds.

Table A-4 PWR-C49E-300AC-F Power Supply Inlet Temperature Versus Fan Speed

Fan Speed Level	Inlet Temperature (T) (± 2°C)	Fan Speed (RPM) (±100RPM)
L1	-3°C < T ≤ 37°C	8700
L2	37°C < T ≤ 44°C	10700
L3	44°C < T ≤ 52°C	12700
L4	T > 52°C	14700

300 W AC-Input Power Supply Power Cords

Table A-5 lists the specifications for the AC power cords that are available for both of the 300 W AC-input power supplies. The table includes references to illustrations of the AC power cords.

**Note**

All 300 W AC-input power supply power cords have an IEC60320/C15 appliance plug at one end. This plug connects to the AC-in receptacle on the power supply faceplate.

Table A-5 300 W AC-Input Power Supply Power Cords

Locale	Power Cord Part Number	AC Source Plug Type	Cordset Rating	Power Cord Reference Illustration
Argentina	CAB-IR2073-C15-AR= (was CAB-7KACR=)	IRAM 2073	10 A, 250 VAC	Figure A-3
Australia, New Zealand	CAB-AS3112-C15-AU= (was CAB-7KACA=)	SAA AS 3112	10 A, 250 VAC	Figure A-4
Continental Europe	CAB-CEE77-C15-EU= (was CAB-7KACE=)	CEE 7/7	10 A, 250 VAC	Figure A-5
Italy	CAB-C2316-C15-IT= (was CAB-7KACI=)	CEI 23-16/7	10 A, 250 VAC	Figure A-6
North America, Japan	CAB-US515-C15-US= (was CAB-7KAC=)	NEMA 5-15 ¹	13 A, 125 VAC	Figure A-7
North America	CAB-N5K6A-NA=	NEMA 6-15P	10 A, 250 VAC	Figure A-8
South Africa, India	CAB-SABS-C15-IND=	BS 546 (SABS 164-1)	10 A, 250 VAC	Figure A-9
Switzerland	CAB-9K10A-SW= (was CAB-7KACSW=)	SEV 1011	10 A, 250 VAC	Figure A-10
United Kingdom	CAB-BS1363-C15-UK= (was CAB-7KACU=)	BS 1363 ²	13 A, 250 VAC	Figure A-11

- For Japan, ask your local electrical contractor to prepare the NEMA 5-20 power plug.
- Plug contains a 13 A fuse.

Figure A-3 CAB-IR2073-C15-AR=, CAB-7KACR= (Argentina)

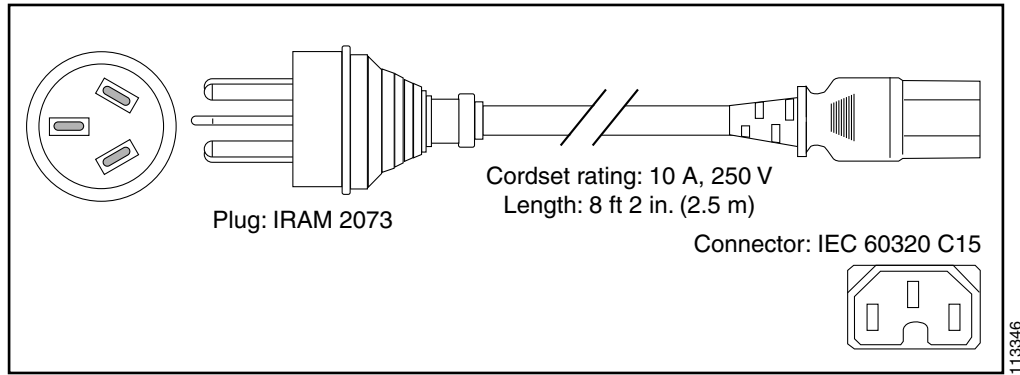

Figure A-4 CAB-AS3112-C15-AU=, CAB-7KACA= (Australia and New Zealand)

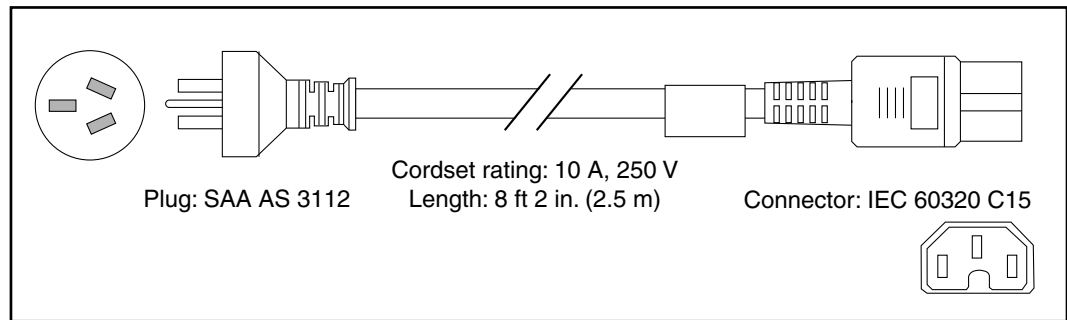

Figure A-5 CAB-CEE77-C15-EU=, CAB-7KACE= (Continental Europe)

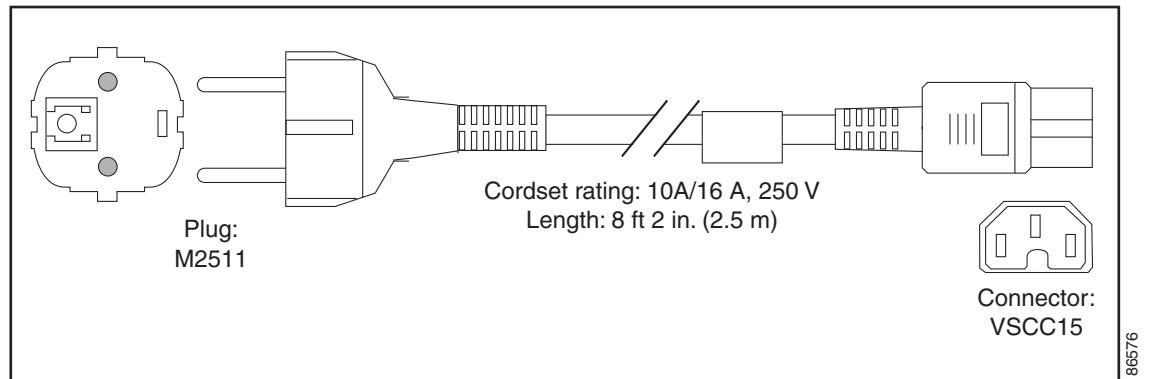

Figure A-6 CAB-C2316-C15-IT=, CAB-7KACI= (Italy)

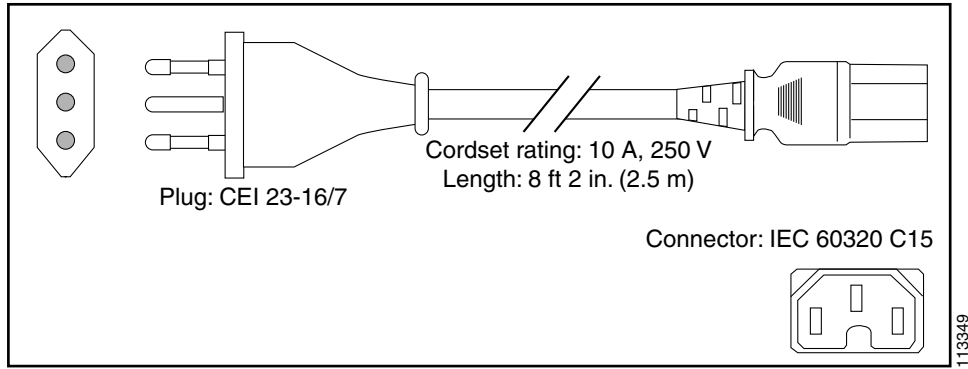

Figure A-7 CAB-US515-C15-US=, CAB-7KAC= (North America)

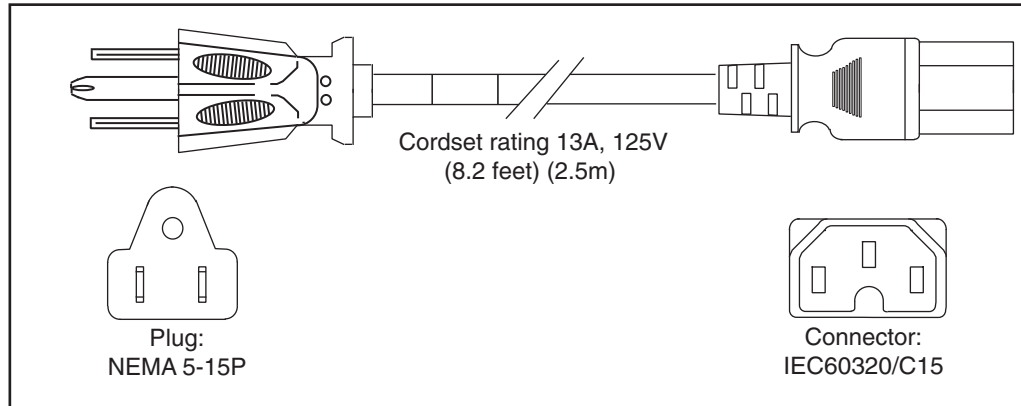

Figure A-8 CAB-N5K6A-NA (North America)

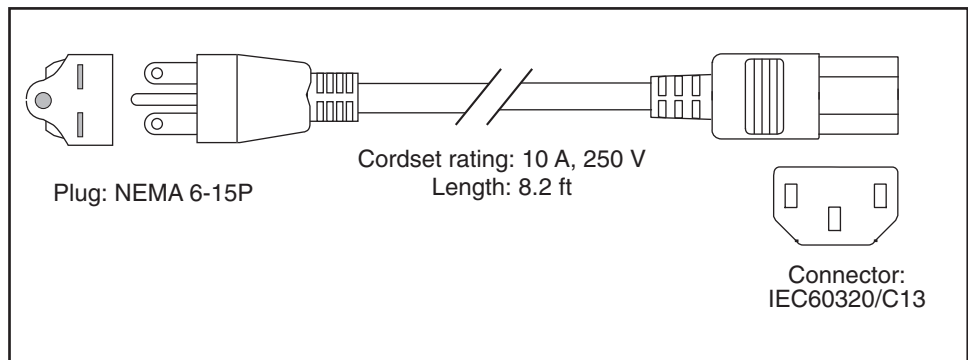

Figure A-9 CAB-SABS-C15-IND (South Africa, India)

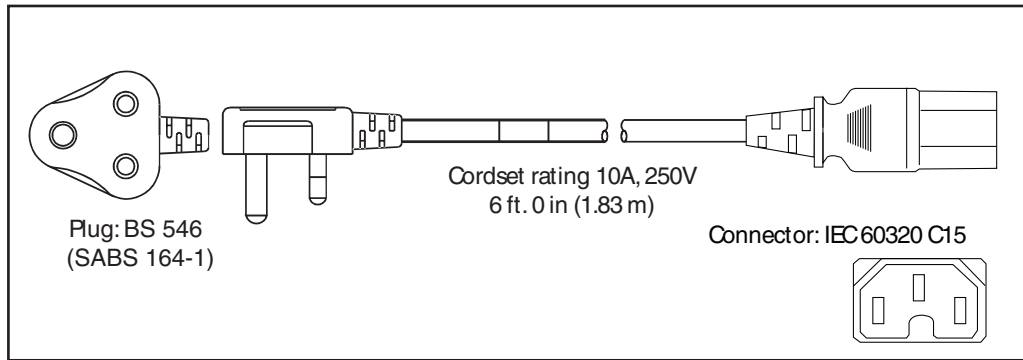

Figure A-10 CAB-9K10A-SW=, CAB-7KACSW= (Switzerland)

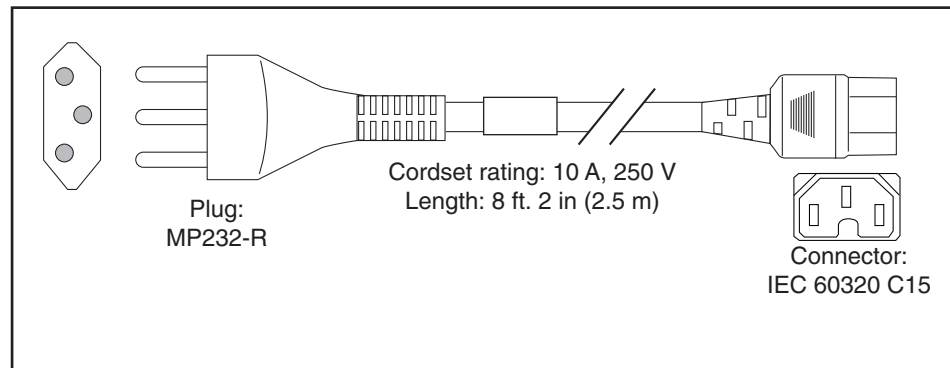
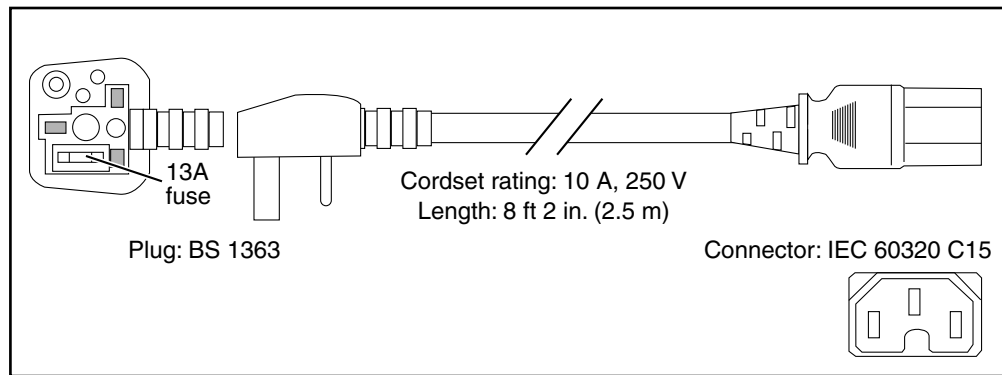

Figure A-11 CAB-BS1363-C15-UK=, CAB-7KACU= (United Kingdom)



300 W DC-Input Power Supply (PWR-C49-300DC)

Figure A-12 shows the 300 W DC-input power supply with the major features identified. The PWR-C49-300DC DC-input power supply is supported only on the Catalyst 4948E switch chassis.

Figure A-12 300 W DC-Input Power Supply (PWR-C49-300DC)

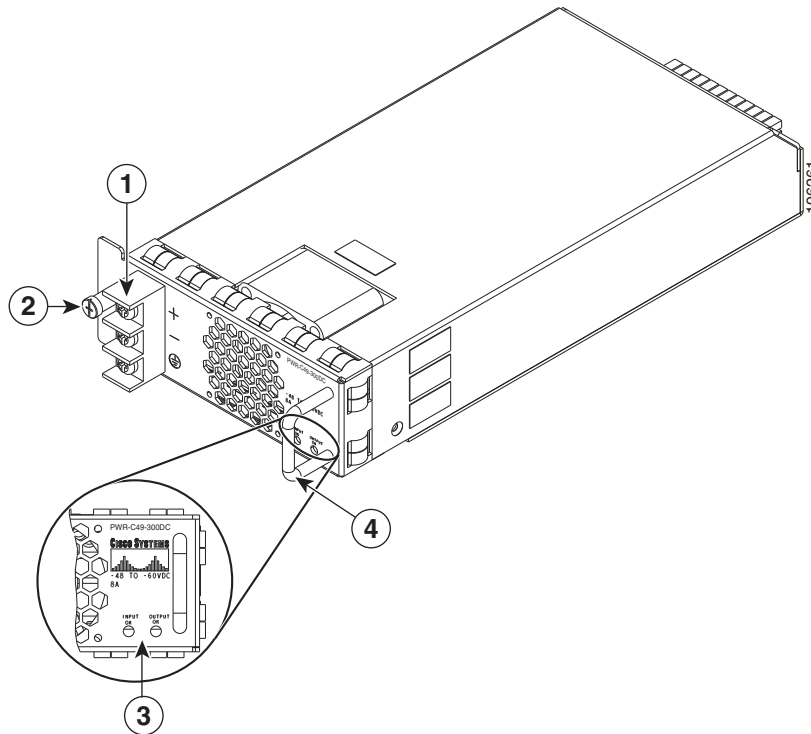

1	Source DC terminal block	3	Power supply LEDs
2	Captive installation screw	4	Power supply handle

Table A-6 lists the specifications for the 300 W DC-input power supply (PWR-C49-300DC).

Table A-6 300 W DC-Input Power Supply Specifications

Item	Specification
DC-input voltage	<ul style="list-style-type: none"> -48 VDC @ 8.33 A for nominal -48 V battery backup system (operating range: -40.5 VDC to -56 VDC) -60 VDC @ 6.66 A for nominal -60 V battery backup system (operating range: -55 VDC to -72 VDC)
DC-input current	Nominal range is 6.66 A to 8.33 A
Power supply output capacity	300 W
Power supply output	25 A @ 12 VDC
Output holdup time	8 ms (minimum)
Heat dissipation	341 BTU/hour (power supply only)

Table A-6 300 W DC-Input Power Supply Specifications (continued)

Item	Specification
Power supply LEDs	
INPUT OK	<ul style="list-style-type: none"> • Green—The INPUT OK LED is lit green when the power supply has detected that the source DC voltage is within limits. The input voltage is $\geq -38.25 \text{ VDC} \pm 2.25 \text{ VDC}$. • Red—The INPUT OK LED is red when either of the following two situations occurs: <ul style="list-style-type: none"> – In chassis that are equipped with dual power supplies, and both power supplies are powered on, the INPUT OK LED is lit red if its source DC voltage falls below 33 VDC ($\pm 3 \text{ VDC}$). – In chassis that are equipped with dual power supplies and one power supply is powered on and the other power supply is powered off, the INPUT OK LED is lit red, rather than unlit, on the power supply that is turned off. • Off—In chassis that are equipped with a single power supply, the INPUT OK LED is off when source DC voltage falls below 33 VDC ($\pm 3 \text{ VDC}$), is not present with the power on/off switch turned on, or the power supply is turned off.
OUTPUT OK	<ul style="list-style-type: none"> • Green—The 12 VDC output is within margins ($11.30 \text{ VDC} < \text{output voltage} < 12.85 \text{ VDC}$). • Red—The OUTPUT OK LED is red when any of the following three situations occurs: <ul style="list-style-type: none"> – In chassis that are equipped with a single power supply, the 12 VDC output is out of tolerance (less than 11.30 VDC or more than 12.85 VDC). – In chassis that are equipped with dual power supplies and one power supply is powered on and the other power supply is powered off, the OUTPUT OK LED is lit red, rather than unlit, on the power supply that is powered off. – The OUTPUT OK LED is also lit red when a power supply fan failure is detected. A fan failure is triggered when the fan rotation drops below $4150 \text{ RPM} \pm 150 \text{ RPM}$. • Off—In chassis that are equipped with a single power supply, the OUTPUT OK LED is off when the power supply is turned off.
Power supply fan	<ul style="list-style-type: none"> • One temperature-controlled, variable-speed fan • Airflow direction—Back to front • The power supply fan has four speed settings. The speed settings are dependent on the inlet air temperature. See Table A-7 for inlet temperature ranges and corresponding fan speeds.
Weight	2 lb (0.9 kg)

Table A-7 DC-Input Power Supply Inlet Temperature Versus Fan Speed

Fan Speed Level	Inlet Temperature (T) (± 2°C)	Fan Speed (RPM) (±100RPM)
L1	$-10^{\circ}\text{C} < T \leq 30^{\circ}\text{C}$	5100
L2	$30^{\circ}\text{C} < T \leq 37^{\circ}\text{C}$	6400
L3	$37^{\circ}\text{C} < T \leq 45^{\circ}\text{C}$	7700
L4	$T > 45^{\circ}\text{C}$	9500



APPENDIX **B**

Transceiver, Chassis Connectors, and Cable and Adapter Specifications

Revised: January 4, 2012

This appendix covers the transceivers supported by the Catalyst 4948E and the Catalyst 4948E-F switches, the connectors on the front panel of the chassis, and the cables and adapters supplied in the accessory kit. The appendix is divided into the following topics:

- [Transceiver Support for Uplink Ports, page B-1](#)
- [Console Port, page B-11](#)
- [Ethernet Management Port, page B-12](#)
- [Cables and Adapters, page B-12](#)



Tip

For additional information about the Cisco Catalyst 4948E and the Catalyst 4948E-F switches (including configuration examples and troubleshooting information), see the documents listed on this page:

http://www.cisco.com/en/US/products/ps6021/tsd_products_support_series_home.html

Transceiver Support for Uplink Ports

Both the Catalyst 4948E and the Catalyst 4948E-F chassis have four uplink ports that support both 1-GB SFP and 10-GB SFP+ transceivers.

1-GB SFP Transceivers

[Table B-1](#) lists the 1-GB SFP transceivers that are supported on the chassis uplink ports.

Table B-1 **1-GB SFP Transceiver Support**

SFP Transceiver	Description
GLC-T	(1000BASE-T)
GLC-SX-MM	(1000BASE-SX)

Table B-1 1-GB SFP Transceiver Support (continued)

SFP Transceiver	Description
GLC-LH-SM	(1000BASE-LH/LX)
GLC-ZX-SM	(1000BASE-ZX)
GLC-BX-D	(1000BASE-BX10)
GLC-BX-U	(1000BASE-BX10)

The four uplink ports also support 1-GB CWDM and 1-GB DWDM SFP transceivers, which are described in separate sections.

Figure B-1 shows a 1000BASE-X (optical) SFP transceiver with the major features of the transceiver identified. Figure B-2 shows a 1000BASE-T (copper) SFP transceiver with the major features of the transceiver identified.

Figure B-1 1-GB Optical SFP Transceiver Features

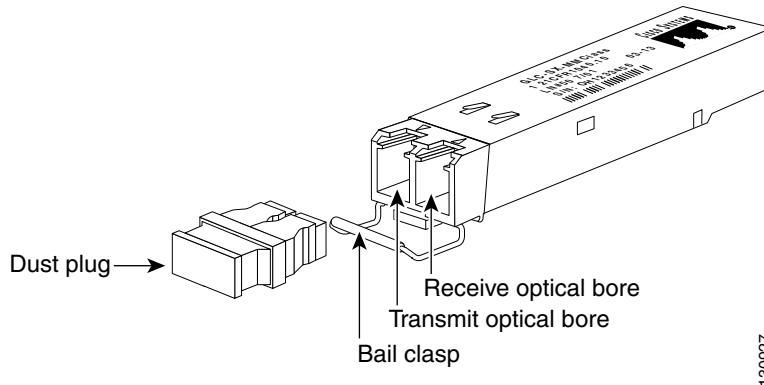
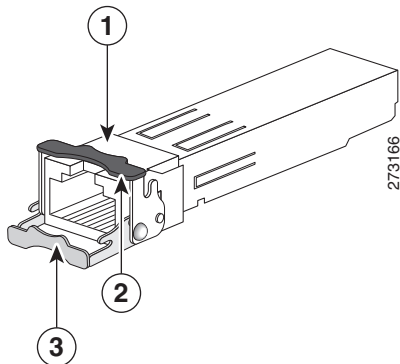

Figure B-2 1-GB Copper SFP Transceiver Features



1	RJ-45 connector	3	Bail-clasp shown in the open (unlocked) position
2	Bail-clasp shown in the closed (locked) position		

Table B-2 lists the specifications for the 1000BASE-T and 1000BASE-X SFP transceivers.

Table B-2 1000BASE-T and 1000BASE-X SFP Transceiver Specifications

SFP Transceiver Module and Product Number	Interface Connector	Nominal Wavelength (nm)	Network Cable Type	Fiber Core Size (micron)	Modal Bandwidth (MHz/km)	Cable Distance ¹
1000BASE-T (GLC-T=)	RJ-45	—	Category 5, 5e, or 6 UTP/FTP	—	—	328 ft (100 m)
1000BASE-SX (GLC-SX-MM=)	LC duplex	850	MMF	62.5 62.5 50.0 50.0	160 200 400 500	722 ft (220 m) 902 ft (275 m) 1640 ft (500 m) 1804 ft (550 m)
1000BASE-LX/LH (GLC-LH-SM=)	LC duplex	1300	MMF ² SMF	62.5 50.0 50.0 G.652 ³	500 400 500 —	1804 ft (550 m) 1804 ft (550 m) 1804 ft (550 m) 6.21 mi (10 km)
1000BASE-ZX (GLC-ZX-SM=)	LC duplex	1550	SMF	G.652 ³	—	43.4 to 62 mi (70 to 100 km) ⁴
1000BASE-BX10 (GLC-BX-D=)	LC single	1490 (downstream)	SMF	G.652 ³	—	6.21 mi (10 km)
1000BASE-BX10 (GLC-BX-U=)	LC single	1310 (upstream)	SMF	G.652 ³	—	6.21 mi (10 km)

1. Cable distances are based on fiber loss. Additional factors, such as the number of splices and the optical quality of the fiber, can affect cabling distances.
2. A mode-conditioning patch cord is required. Using an ordinary patch cord with MMF, 1000BASE-LX/LH SFP transceivers, and a short link distance can cause transceiver saturation, resulting in an elevated bit error rate (BER). When using the LX/LH SFP transceiver with 62.5-micron diameter MMF, you must also install a mode-conditioning patch cord between the SFP transceiver and the MMF cable on both the sending and receiving ends of the link. The mode-conditioning patch cord is required for link distances greater than 984 ft (300 m).
3. ITU-T G.652 SMF as specified by the IEEE 802.3z standard.
4. 1000BASE-ZX SFP modules can reach up to 62 miles (100 km) by using dispersion-shifted SMF or low-attenuation SMF; the actual distance depends on the fiber quality, the number of splices, and the connectors.

Table B-3 lists the fiber loss budgets for the 1000BASE-T and 1000BASE-X SFP transceivers.

Table B-3 Fiber Loss Budgets for the 1-GB SFP Transceivers

1-GB SFP Transceiver Product Number	Transmit Power (dBm)	Receive Power (dBm)	Transmit and Receive Wavelengths (nm)
GLC-SX-MM (1000BASE-SX)	-4 (maximum) -9.5 (minimum)	0 (maximum) -17 (minimum)	770 to 860
GLC-LH-SM (1000BASE-LX/LH)	-3 (maximum) -9.5 (minimum)	-3 (maximum) -20 (minimum)	1260 to 1355
GLC-ZX-SM (1000BASE-ZX)	5 (maximum) 0 (minimum)	-3 (maximum) -23 (minimum)	1500 to 1580
GLC-BX-D (1000BASE-BX-D)	-3 (maximum) -9 (minimum)	-3 (maximum) -19.5 (minimum)	1480 to 1500 (transmit) 1260 to 1360 (receive)
GLC-BX-U (1000BASE-BX-U)	-3 (maximum) -9 (minimum)	-3 (maximum) -19.5 (minimum)	1260 to 1360 (transmit) 1480 to 1500 (receive)



Note

For the GLC-ZX-SM, the minimum attenuation between the transmit bore (TX) and the receive bore (RX) is 8 db. When using short distances of single-mode fiber cable, you might need to insert an inline optical attenuator in the link to avoid overloading the receiver.

Table B-4 lists the physical and environmental specifications for the 1-GB SFP transceivers.

Table B-4 1-GB SFP Transceiver Physical and Environmental Specifications

Item	Specification
Dimensions (H x W x D)	0.04 x 0.53 x 2.22 in. (8.5 x 13.4 x 56.5 mm)
Operating temperature	32° to 122°F (0° to 50°C)
Storage temperature	-40° to 185°F (-40° to 85°C)



Note

You can use any combination of SFP modules that your Cisco device supports. The only restrictions are that each SFP port must match the wavelength specifications on the other end of the cable and that the cable must not exceed the stipulated cable length for reliable communications.

CWDM SFP Transceivers

The four uplink ports on the switches also support CWDM SFP transceivers. The CWDM SFP transceiver uses an LC optical connector to connect to single-mode fiber-optic (SMF) cable. You can connect the CWDM SFPs to CWDM passive optical system optical add/drop multiplexer (OADM) modules or multiplexer/demultiplexer plug-in modules using single-mode fiber-optic cables. The supported CWDM SFP transceivers, their associated wavelengths, and their connector color codes are listed in Table B-5

Table B-5 CWDM SFP Transceivers

CWDM SFP Transceiver Product Number	Description	Connector Color Code
CWDM-SFP-1470=	1000BASE-CWDM, 1470 nm	Gray
CWDM-SFP-1490=	1000BASE-CWDM, 1490 nm	Violet
CWDM-SFP-1510=	1000BASE-CWDM, 1510 nm	Blue
CWDM-SFP-1530=	1000BASE-CWDM, 1530 nm	Green
CWDM-SFP-1550=	1000BASE-CWDM, 1550 nm	Yellow
CWDM-SFP-1570=	1000BASE-CWDM, 1570 nm	Orange
CWDM-SFP-1590=	1000BASE-CWDM, 1590 nm	Red
CWDM-SFP-1610=	1000BASE-CWDM, 1610 nm	Brown

Table B-6 lists the optical specifications for the CWDM SFP transceivers.

Table B-6 CWDM SFP Optical Specifications

Parameter	Minimum	Typical	Maximum	Units	Notes and Conditions
Transmitter Center Wavelength	(x-4)	—	(x + 7)	nm	Available center wavelengths are 1470, 1490, 1510, 1530, 1550, 1570, 1590, and 1610 nm
Side-Mode Suppression Ratio	30	—		dB	
Transmitter Optical Output Power	0	—	5.0	dBm	Average power coupled into single-mode fiber
Receiver Optical Input Power (BER <10 ⁻¹² with PRBS 2-7-1)	-28.0	—	-7.0	dBm	Measured at 2.12 Gbps, 140°F (60°C) case temperature
Receiver Optical Input Power (BER <10 ⁻¹² with PRBS 2-7-1)	-29.0	—	-7.0	dBm	Measured at 1.25 Gbps, 140°F (60°C) case temperature
Receiver Optical Input Wavelength	1450	—	1620	nm	
Transmitter Extinction Ratio	9	—		dB	
Dispersion Penalty at 100 km	—	—	3	dB	Measured at 2.12 Gbps
Dispersion Penalty at 100 km	—	—	2	dB	Measured at 1.25 Gbps

Table B-7 lists the physical and environmental specifications for the CWDM SFP transceivers.

Table B-7 1-GB CWDM SFP Transceiver Physical and Environmental Specifications

Item	Specification
Dimensions (H x W x D)	0.04 x 0.53 x 2.22 in. (8.5 x 13.4 x 56.5 mm)
Operating temperature	32° to 122°F (0° to 50°C)
Storage temperature	-40° to 185°F (-40° to 85°C)

DWDM SFP Transceivers

The four uplink ports on both the Catalyst 4948E and the Catalyst 4948E-F switches also support DWDM SFP transceivers. The DWDM SFP transceiver uses an LC optical connector to connect to single-mode fiber-optic (SMF) cable. You can connect the DWDM SFPs to DWDM passive optical system optical add/drop multiplexer (OADM) modules or multiplexer/demultiplexer plug-in modules using single-mode fiber-optic cables. The supported CWDM SFP transceivers, their associated wavelengths, and their connector color codes are listed in [Table B-8](#).

Table B-8 DWDM SFP Transceiver Product Numbers, Wavelengths, and ITU Channel Numbers

DWDM SFP Product Number	Description	ITU Channel
DWDM-SFP-6061	1000BASE-DWDM 1560.61 nm SFP	21
DWDM-SFP-5979	1000BASE-DWDM 1559.79 nm SFP	22
DWDM-SFP-5898	1000BASE-DWDM 1558.98 nm SFP	23
DWDM-SFP-5817	1000BASE-DWDM 1558.17 nm SFP	24
DWDM-SFP-5655	1000BASE-DWDM 1556.55 nm SFP	26
DWDM-SFP-5575	1000BASE-DWDM 1555.75 nm SFP	27
DWDM-SFP-5494	1000BASE-DWDM 1554.94 nm SFP	28
DWDM-SFP-5413	1000BASE-DWDM 1554.13 nm SFP	29
DWDM-SFP-5252	1000BASE-DWDM 1552.52 nm SFP	31
DWDM-SFP-5172	1000BASE-DWDM 1551.72 nm SFP	32
DWDM-SFP-5092	1000BASE-DWDM 1550.92 nm SFP	33
DWDM-SFP-5012	1000BASE-DWDM 1550.12 nm SFP	34
DWDM-SFP-4851	1000BASE-DWDM 1548.51 nm SFP	36
DWDM-SFP-4772	1000BASE-DWDM 1547.72 nm SFP	37
DWDM-SFP-4692	1000BASE-DWDM 1546.92 nm SFP	38
DWDM-SFP-4612	1000BASE-DWDM 1546.12 nm SFP	39
DWDM-SFP-4453	1000BASE-DWDM 1544.53 nm SFP	41
DWDM-SFP-4373	1000BASE-DWDM 1543.73 nm SFP	42
DWDM-SFP-4294	1000BASE-DWDM 1542.94 nm SFP	43
DWDM-SFP-4214	1000BASE-DWDM 1542.14 nm SFP	44
DWDM-SFP-4056	1000BASE-DWDM 1540.56 nm SFP	46
DWDM-SFP-3977	1000BASE-DWDM 1539.77 nm SFP	47
DWDM-SFP-3998	1000BASE-DWDM 1539.98 nm SFP	48
DWDM-SFP-3819	1000BASE-DWDM 1538.19 nm SFP	49
DWDM-SFP-3661	1000BASE-DWDM 1536.61 nm SFP	51

Table B-8 DWDM SFP Transceiver Product Numbers, Wavelengths, and ITU Channel Numbers (continued)

DWDM SFP Product Number	Description	ITU Channel
DWDM-SFP-3582	1000BASE-DWDM 1535.82 nm SFP	52
DWDM-SFP-3504	1000BASE-DWDM 1535.04 nm SFP	53
DWDM-SFP-3425	1000BASE-DWDM 1534.25 nm SFP	54
DWDM-SFP-3268	1000BASE-DWDM 1532.68 nm SFP	56
DWDM-SFP-3190	1000BASE-DWDM 1531.90 nm SFP	57
DWDM-SFP-3112	1000BASE-DWDM 1531.12 nm SFP	58
DWDM-SFP-3033	1000BASE-DWDM 1530.33 nm SFP	59

Table B-9 lists the DWDM SFP transceiver optical specifications.

Table B-9 DWDM SFP Transceiver Optical Specifications

Specification	Value
Transmitter spectral width	0.2 nm
Transmitter optical output power	<ul style="list-style-type: none"> • 0 dBm (minimum) • 4.0 dBm (maximum)
Receiver optical input wavelength	<ul style="list-style-type: none"> • 1530 nm (minimum) • 1565 nm (maximum)
Receiver optical input power	<ul style="list-style-type: none"> • -28.0 dBm (minimum)¹ • -22.0 dBm (minimum)² • -9.0 dBm (maximum)

1. Power-limited performance.

2. Noise-limited performance.

Table B-10 lists the physical and environmental specifications for the DWDM SFP transceivers.

Table B-10 DWDM SFP Transceiver Physical and Environmental Specifications

Item	Specification
Dimensions (H x W x D)	0.04 x 0.53 x 2.22 in. (8.5 x 13.4 x 56.5 mm)
Operating temperature	32° to 122°F (0° to 50°C)
Storage temperature	-40° to 185°F (-40° to 85°C)

10-GB SFP+ Transceivers

The Small Form-Factor Pluggable, enhanced (SFP+) 10-Gigabit Ethernet transceiver module is a bidirectional transceiver. It has a 20-pin connector on the electrical interface and a duplex LC connector on the optical interface. The following SFP+ transceivers are supported in the uplink ports:

- SFP-10G-SR
- SFP-10G-LR
- SFP-10G-LRM
- SFP-H10GB-CU1M
- SFP-H10GB-CU3M
- SFP-H10GB-CU5M

Figure B-3 shows an SFP+ optical transceiver with the major features identified. Figure B-4 shows a copper (twinax) transceiver.

Figure B-3 SFP+ Optical Transceiver

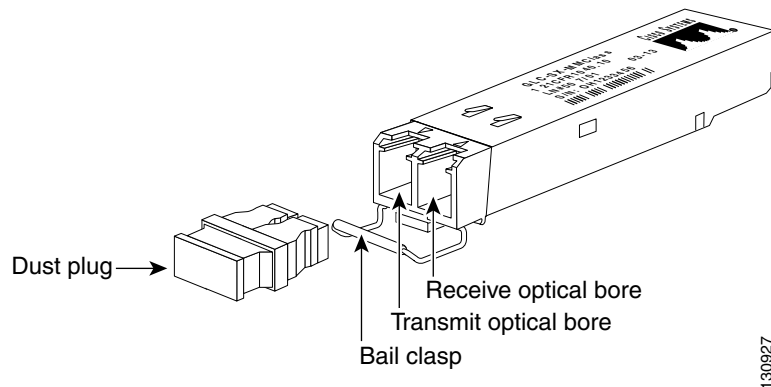
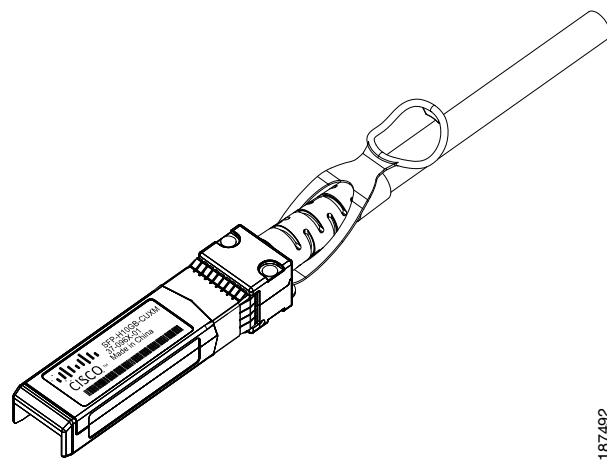

Figure B-4 shows the SFP+ copper (twinax) transceiver.

Figure B-4 SFP+ 10-Gigabit Ethernet Copper (Twinax) Transceiver



**Note**

When switching from 1-GB SFPs to 10-GB SFP+ transceivers or from an SFP+ to an SFP, the chassis recognizes the change in speed and sets the port accordingly.

The 10-GB SFP+ transceiver cabling specifications are listed in [Table B-11](#).

Table B-11 10-GB SFP+ Transceiver Cabling Specifications

SFP+ Transceiver	Wavelength (nm)	Cable Type	Core Size (μm)	Modal Bandwidth (MHz/km)	Cable Distance
SFP-10G-SR (Beige bail-clasp)	850	MMF	62.5	160	85 ft (26 m)
			62.5	200	108 ft (33 m)
			50.0	400	216 ft (66 m)
			50.0	500	269 ft (82 m)
			50.0	2000	984 ft (300 m)
SFP-10G-LR (Blue bail-clasp)	1310	SMF	G.652	—	6.2 miles (10 km)
SFP-10G-LRM	1310	MMF	62.5	500	722 ft (220 m)
			50.0	400	328 ft (100 m)
			50.0	500	722 ft (220 m)
		SMF	G.652	—	984 ft (300 m)
SFP-H10GB-CU1M	—	Twinax cable, 30AWG cable assembly	—	—	3.28 ft (1 m)
SFP-H10GB-CU3M	—	Twinax cable, 30AWG cable assembly	—	—	9.84 ft (3 m)
SFP-H10GB-CU5M	—	Twinax cable, 30AWG cable assembly	—	—	16.4 ft (5 m)

Table B-12 lists the SFP+ transceiver optical transmit and receive specifications.

Table B-12 SFP+ Transceiver Module Optical Transmit and Receive Specifications

SFP+ Transceiver Module Model	Transceiver Type	Transmit Power (dBm)	Receive Power (dBm)	Transmit and Receive Wavelength (nm)
SFP-10G-SR	10GBASE-SR, 850-nm MMF	-1.3 (Max) -7.3 (Min)	-1.0 (Max) -9.9 (Min)	840 to 860
SFP-10G-LR	10GBASE-LR, 1310-nm SMF	0.5 (Max) -8.2 (Min)	0.5 (Max) -14.4 (Min)	1260 to 1355
SFP-10G-LRM	10GBASE-LRM, 1310-nm MMF and SMF	0.5 (Max) -6.5 (Min)	0.5 (Max) -8.4 (Min average) -6.4 (Min in OMA)	1260 to 1355

Table B-13 lists the physical and environmental specifications for the 10-GB SFP+ transceivers.

Table B-13 10-GB SFP+ Transceiver Physical and Environmental Specifications

Item	Specification
Dimensions (H x W x D)	0.04 x 0.53 x 2.22 in. (8.5 x 13.4 x 56.5 mm)
Operating temperature	32° to 122°F (0° to 50°C)
Storage temperature	-40° to 185°F (-40° to 85°C)

Console Port

Both the Catalyst 4948E and the Catalyst 4948E-F switches can be accessed through a serial console port located on the chassis front panel. The console port is 10/100/1000BASE-T port that uses an RJ-45 connector. The console port allows you to access the switch either locally (with a console terminal or PC) or remotely (with a modem).

Table B-14 lists the console port pinouts.

Table B-14 Console Port Pinouts

Pin	Signal	Direction	Description
1	RTS	output	request to send
2	DTR	output	data terminal ready
3	TXD	output	transmit data
4	GND	—	—
5	GND	—	—
6	RXD	input	receive data
7	DSR	input	data set ready
8	CTS	input	clear to send

The two-color LINK LED associated with the console port provides visual status for the port:

- Green—Link is established
- Amber—Administrative disabled
- Off—No link is detected

Ethernet Management Port

The Ethernet management port supports 10/100/1000BASE-T Ethernet. It can autonegotiate to operate at any line speed (10, 100, 1000 Mbps); full and half duplex modes for 10 and 100 Mbps line speed, and only full duplex at 1000 Mbps. The Ethernet management port has an RJ-45 connector with an associated Link Status LED. [Table B-15](#) lists the 10/100BASE-T port pinouts.

Table B-15 10/100/1000BASE-T Ethernet Management Port Pinout

Pin	Signal	Direction	Description
1	RXDP	input	receive data
2	RXDN	input	receive data
3	TXDP	output	transmit data
4	unused	—	—
5	unused	—	—
6	TXDN	output	transmit data
7	unused	—	—
8	unused	—	—

The two-color LINK LED associated with the Ethernet management port provides visual status for the port:

- Green—Link is established.
- Amber—Administrative disabled.
- Off—No link is detected.

Cables and Adapters

One cable adapter plug is supplied in the accessory kit for both switches.



Note

A console cable is not provided in the accessory kit. It can be ordered as an option.

Rollover Cable

You can use an optional RJ-45 rollover cable and the supplied RJ-45/DSUB F/F adapter to connect the chassis console port to a computer running terminal emulation software. [Table C-2](#) lists the pinouts for the console port, the RJ-45 rollover cable, and the RJ-45/DSUB F/F adapter.

You can identify a rollover cable by comparing the two ends of the cable. Holding the cables side by side, with the tab at the back, the wire connected to the pin on the outside of the left plug should be the same color as the wire connected to the pin on the outside of the right plug. (See [Figure B-5](#).) If your cable was purchased from Cisco Systems, pin 1 will be white on one connector, and pin 8 will be white on the other. (A rollover cable reverses pins 1 and 8, 2 and 7, 3 and 6, and 4 and 5.)

Figure B-5 Identifying a Rollover Cable

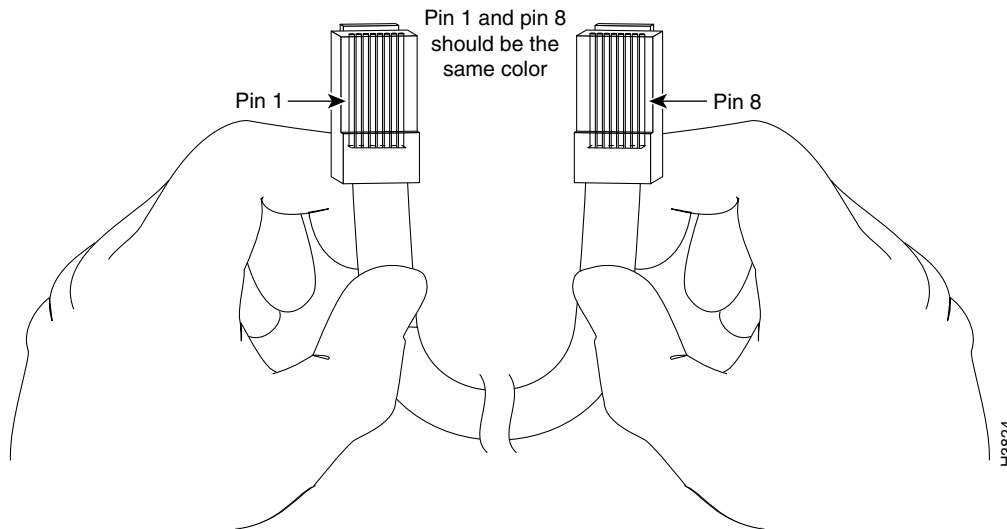

Rollover Cable RJ-45 to DB-9 Adapter (For Connecting to a PC)

Use an RJ-45-to-RJ-45 rollover cable and the RJ-45-to-DB-9 female DTE adapter (labeled Terminal) to connect the console port to a PC running terminal emulation software. [Table B-16](#) lists the pinouts for the asynchronous serial console port, the RJ-45-to-RJ-45 rollover cable, and the RJ-45-to-DB-9 female DTE adapter.

Table B-16 Port Mode 1 Signaling and Pinouts (DB-9 Adapter)

Console Port	RJ-45-to-RJ-45 Rollover Cable		RJ-45-to-DB-9 Terminal Adapter	Console Device
	RJ-45 Pin	RJ-45 Pin	DB-9 Pin	
RTS	1 ¹	8	8	CTS
DTR	2	7	6	DSR
TxD	3	6	2	RxD
GND	4	5	5	GND
GND	5	4	5	GND
RxD	6	3	3	TxD
DSR	7	2	4	DTR
CTS	8 ¹	1	7	RTS

1. Pin 1 is connected internally to Pin 8.



APPENDIX **C**

Troubleshooting the Installation

This chapter describes how to troubleshoot the switch hardware installation and contains these sections:

- [Getting Started, page C-2](#)
- [Problem Solving to the System Component Level, page C-2](#)
- [Identifying Startup Problems, page C-2](#)
- [Troubleshooting the Power Supply, page C-4](#)
- [Contacting Customer Service, page C-4](#)

If your system has problems starting up, use the information in this chapter to help isolate the cause. Problems with the initial startup are often caused by poor or improper connections. Although temperature conditions above the maximum acceptable level rarely occur at initial startup, environmental monitoring functions are included because they also monitor DC-line voltages.



Note

For configuration questions or problems, refer to the software configuration guide or the command reference publication.



Tip

For additional information about the Cisco Catalyst 4948E switch (including configuration examples and troubleshooting information), see the documents listed on this page:

http://www.cisco.com/en/US/products/ps6021/tsd_products_support_series_home.html

Getting Started

When the initial system boot is complete, verify the following:

- Power supplies are supplying power to the system.
- The system fan assembly is operating.
- System software boots successfully.

If all of these conditions are met and the hardware installation is complete, refer to the *Catalyst 4500 Series Switch Cisco IOS Software Configuration Guide* and the *Catalyst 4500 Series Switch Cisco IOS Command Reference* publications to troubleshoot the software. However, if any of these conditions are not met, use the procedures in this chapter to isolate and, if possible, resolve the problem.

Problem Solving to the System Component Level

The key to success when troubleshooting the system is to isolate the problem to a specific system component. The first step is to compare what the system *is doing* to what it *should be doing*. Because a startup problem can usually be attributed to a single component, it is more efficient to isolate the problem to a subsystem rather than troubleshoot each separate component in the system.

The switch consists of the following subsystems:

- Power supply—Includes the power supply and power supply cooling. (See the [“Troubleshooting the Power Supply”](#) section on page C-4.)
- Fan assembly system—The chassis fan assembly should operate whenever system power is on. Usually, it continues to operate even when the environmental monitor shuts down the system because of an overtemperature or overvoltage condition. (It will shut down for a power supply shutdown.) You should be able to hear the fan assembly to determine whether or not it is operating. If the FAN LED is red and you determine that one or more of the fans in the fan assembly is not operating, you should immediately contact a customer service representative. There are no installation adjustments that you can make if the fan assembly does not function properly at the initial startup; the fan tray needs to be replaced.

Identifying Startup Problems

When you connect the power cords to the switch, follow these steps:

-
- Step 1** Set the power switches to the on position (AC powered systems only).
 - Step 2** Verify that power is available to the power supplied from the site AC or DC source. Turn on breakers and fuses if necessary.
 - Step 3** Listen for the system fan assembly. If you do not immediately hear the system fan assembly begin to operate, see [“Troubleshooting the Power Supply”](#) section on page C-4.
 - Step 4** If you determine that the power supplies are functioning normally and that the fan tray is faulty, contact a customer service representative. If the system fan assembly does not function properly at initial startup, there are no installation adjustments that you can make.
-

LED Readings

LEDs indicate all system states in the startup sequence. By checking the LEDs, you can determine when and where the system failed in the startup sequence. To check the LEDs, follow these steps:

- Step 1** Compare the LED states to those in [Table C-1](#).

Table C-1 Power Supply LED Meanings

LED and Color	Meaning
INPUT OK (AC)	<p>This LED should turn green immediately when power is applied to the supply and the power switch is set to ON.</p> <ul style="list-style-type: none"> Green—AC input voltage is greater than 82 ± 3 V. Red—In a dual power supply configuration (alternate unit powered) the AC input is less than 73 ± 3 V, or the power supply is turned off. Off—AC input voltage is less than 73 ± 3 V, or the power supply is turned off.
INPUT OK (DC)	<p>This LED should turn green immediately when power is applied to the supply.</p> <ul style="list-style-type: none"> Green—DC input voltage is greater than -38.25 ± 2.25 V. Red—In a dual power supply configuration (alternate unit powered) the DC input is less than 33 ± 3 V, or the power supply is turned off. Off—In a single supply configuration, the LED shall be off to signal that DC input is less than 33 ± 3 V, or the power supply is turned off.
OUTPUT OK	<ul style="list-style-type: none"> Green—DC output voltages are within the normal operating range. Red—Output voltage between the minimum and maximum limits will not create an output fail alarm. Output voltages below the minimum or above the maximum will create an output fail alarm and cause the LED to illuminate red.

- Step 2** Verify that the LEDs on the front panel are lit:
- The STATUS LED flashes orange during diagnostic boot tests. It is green when the switch is operational (online). If the system software is unable to start up, this LED stays orange.
 - The port LEDs (1-48 plus the 4 SFP/SFP+ ports) are green when the port is operational (online). If no signal is detected, the LINK LED is off. The port LED remains orange if the port is disabled. The port orange flashes yellow if the port tested faulty at startup.
- Step 3** If a STATUS LED is red, contact a customer service representative for instructions.
- Step 4** If the boot information and system banner are not displayed, verify that the terminal is set correctly and that it is connected properly to the console port.
-

Troubleshooting the Power Supply

To help isolate a power subsystem problem, follow these steps:

-
- Step 1** Verify that the power supply is plugged in and that the on/off switch is set to ON (if the power supply is an AC-input power supply).
- Step 2** Look at the power supply LED (PS1 or PS2). If the LED is off or if the LED is red, unplug the power cord, and then plug the power cord in. Be sure the on/off switch is OFF before removing the power cord from the power supply.
- If the LED remains off, there might be a problem with the AC or DC source or the power cable.
- Step 3** Connect the power cord to another power source if one is available.
- Step 4** If the LED then lights, the problem is the first power source.
- Step 5** If the LED fails to light after you connect the power supply to a new power source, replace the power cord.
- If the LED still fails to light when the switch is connected to a different power source with a new power cord, the power supply is probably faulty.
- Step 6** If you are unable to resolve the problem, contact a customer service representative for instructions.
-

Contacting Customer Service

If you are unable to solve a startup problem after using the troubleshooting suggestions in this chapter, contact a customer service representative for assistance and further instructions. Before you call, have the following information ready to help your service provider assist you as quickly as possible:

- Date you received the switch
- Chassis serial number (located on a label on the top of the chassis)
- Type of software and release number
- Maintenance agreement or warranty information
- Brief description of the problem
- Brief explanation of the steps you have already taken to isolate and resolve the problem



APPENDIX **D**

Regulatory Compliance and Safety Information



Note

Only trained and qualified service personnel (as defined in IEC 60950-1 and AS/NZS 60950) should install, replace, or service the equipment. Install the system in accordance with the U.S. National Electric Code if you are in the United States.



Warning

IMPORTANT SAFETY INSTRUCTIONS

This warning symbol means danger. You are in a situation that could cause bodily injury. Before you work on any equipment, be aware of the hazards involved with electrical circuitry and be familiar with standard practices for preventing accidents. Use the statement number provided at the end of each warning to locate its translation in the translated safety warnings that accompanied this device.
Statement 1071

SAVE THESE INSTRUCTIONS

This appendix includes the following sections:

- [Translated Safety Warnings, page D-2](#)
- [Regulatory Standards Compliance, page D-40](#)
- [GR-1089-CORE Issue 3 Documentation Statements, page D-42](#)
- [GR-1089-CORE Issue 4 Documentation Statements, page D-42](#)
- [European Directives, page D-43](#)
- [Statement 6005—California Perchlorate Contamination Prevention Act \(Title 22, California Code of Regulations, Chapter 33\), page D-43](#)
- [EMC Class A Notices and Warnings, page D-44](#)



Tip

For additional information about the Cisco Catalyst 4948E and the Catalyst 4948E-F switches (including configuration examples and troubleshooting information), see the documents listed on this page:

http://www.cisco.com/en/US/products/ps6021/tsd_products_support_series_home.html

Translated Safety Warnings

This section repeats in multiple languages the warnings in this guide.

Statement 17—Overtemperature Warning



Warning

To prevent the switch from overheating, do not operate it in an area that exceeds the maximum recommended ambient temperature of 104°F (40°C). To prevent airflow restriction, allow at least 3 inches (7.6 cm) of clearance around the ventilation openings.

Waarschuwing

Om oververhitting van de schakelaar te voorkomen, mag u die niet bedienen in een ruimte die de maximale aanbevolen omgevingstemperatuur van 104°F (40°C) overschrijdt. Om beperking van de luchtstroom te voorkomen, dient u ten minste 3 inch (7,6 cm) speling te laten rondom de ventilatie-openingen.

Varoitus

Estääksesi kytkimen ylikuumentumisen älä käytä sitä sellaisissa paikoissa, joiden lämpötila ylittää ympäristön enimmäislämpötilaksi suositellun 40°C. Jätä vähintään 7,6 cm:n vapaa tila tuuletusaukkojen ympärille, jotta ilma pääsee vapaasti virtaamaan.

Attention

Pour éviter une surchauffe du commutateur, ne pas le faire fonctionner dans un local dont la température ambiante dépasse le maximum recommandé de 40°C (104°F). Pour faciliter la circulation d'air, aménager un dégagement d'au moins 7,6 cm (3 pouces) autour des bouches d'aération.

Warnung

Um eine Überhitzung des Schalters zu vermeiden, ist das System nicht in einem Bereich zu betreiben, in dem die empfohlene Höchsttemperatur von 40°C überschritten wird. Damit der Luftfluß nicht behindert wird, ist ein Freiraum von mindestens 7,6 cm um die Belüftungsöffnungen herum einzuhalten.

Avvertenza

Per evitare il surriscaldamento dell'interruttore, non usare l'apparecchiatura in un'area che supera la temperatura ambientale minima consigliata di 40°C. Per evitare una limitazione del flusso dell'aria, lasciare come minimo uno spazio libero di 7,6 cm intorno alle aperture di ventilazione.

Advarsel

For å unngå at bryteren overopphetes skal utstyret ikke brukes på steder hvor anbefalt maks omgivelsestemperatur overstiger 104 grader Farenheit (40°C). La det være minst 3 tommer (7,6 cm) klaring rundt ventilasjonsåpningene for at luftsirkulasjonen skal være uhindret.

Aviso

Para evitar sobreaquecimento do interruptor, não utilize o equipamento numa área que exceda uma temperatura máxima de 40°C. Para evitar o bloqueamento da circulação de ar, deixe pelo menos um espaço de 7.6 cm em volta das aberturas de ventilação.

- ¡Advertencia!** Para evitar que el interruptor se recaliente, no se debe usar en áreas cuya temperatura ambiente exceda la máxima recomendada, esto es, 40°C (104°F). Para no entorpecer la corriente de aire, dejar por lo menos 7,6 cm (3 pulgadas) de espacio muerto alrededor de la rejilla de ventilación.
- Varning!** I syfte att undvika överhettning av switchen skall den inte användas i utrymmen vars temperatur överskrider den maximalt rekommenderade omgivningstemperaturen som är 40°C. Kontrollera att det finns minst 7,6 cm fritt utrymme runt ventilationsöppningarna så att luftflödet inte begränsas.

Statement 37—Restricted Area Warning



Warning

This unit is intended for installation in restricted access areas. A restricted access area is where access can only be gained by service personnel through the use of a special tool, lock and key, or other means of security, and is controlled by the authority responsible for the location.

Waarschuwing

Dit toestel is bedoeld voor installatie op plaatsen met beperkte toegang. Een plaats met beperkte toegang is een plaats waar toegang slechts door servicepersoneel verkregen kan worden door middel van een speciaal instrument, een slot en sleutel, of een ander veiligheidsmiddel, en welke beheerd wordt door de overheidsinstantie die verantwoordelijk is voor de locatie.

Varoitus

Tämä laite on tarkoitettu asennettavaksi paikkaan, johon pääsy on rajoitettua. Paikka, johon pääsy on rajoitettua, tarkoittaa paikkaa, johon vain huoltohenkilöstö pääsee jonkin erikoistyökalun, lukkoon sopivan avaimen tai jonkin muun turvalaitteen avulla ja joka on paikasta vastuussa olevien toimivaltaisten henkilöiden valvoma.

Attention

Cet appareil est à installer dans des zones d'accès réservé. Ces dernières sont des zones auxquelles seul le personnel de service peut accéder en utilisant un outil spécial, un mécanisme de verrouillage et une clé, ou tout autre moyen de sécurité. L'accès aux zones de sécurité est sous le contrôle de l'autorité responsable de l'emplacement.

Warnung

Diese Einheit ist zur Installation in Bereichen mit beschränktem Zutritt vorgesehen. Ein Bereich mit beschränktem Zutritt ist ein Bereich, zu dem nur Wartungspersonal mit einem Spezialwerkzeugs, Schloß und Schlüssel oder anderer Sicherheitsvorkehrungen Zugang hat, und der von dem für die Anlage zuständigen Gremium kontrolliert wird.

Avvertenza

Questa unità deve essere installata in un'area ad accesso limitato. Un'area ad accesso limitato è un'area accessibile solo a personale di assistenza tramite un'attrezzo speciale, lucchetto, o altri dispositivi di sicurezza, ed è controllata dall'autorità responsabile della zona.

Advarsel

Denne enheten er laget for installasjon i områder med begrenset adgang. Et område med begrenset adgang gir kun adgang til servicepersonale som bruker et spesielt verktøy, lås og nøkkel, eller en annen sikkerhetsanordning, og det kontrolleres av den autoriteten som er ansvarlig for området.

Aviso

Esta unidade foi concebida para instalação em áreas de acesso restrito. Uma área de acesso restrito é uma área à qual apenas tem acesso o pessoal de serviço autorizado, que possua uma ferramenta, chave e fechadura especial, ou qualquer outra forma de segurança. Esta área é controlada pela autoridade responsável pelo local.

¡Advertencia!	Esta unidad ha sido diseñada para instalarse en áreas de acceso restringido. Área de acceso restringido significa un área a la que solamente tiene acceso el personal de servicio mediante la utilización de una herramienta especial, cerradura con llave, o algún otro medio de seguridad, y que está bajo el control de la autoridad responsable del local.
Varning!	Denna enhet är avsedd för installation i områden med begränsat tillträde. Ett område med begränsat tillträde får endast tillträdas av servicepersonal med ett speciellt verktyg, lås och nyckel, eller annan säkerhetsanordning, och kontrolleras av den auktoritet som ansvarar för området.

Statement 39—Grounded Equipment Warning



Warning

This equipment is intended to be grounded. Ensure that the host is connected to earth ground during normal use.

Waarschuwing

Deze apparatuur hoort geaard te worden. Zorg dat de host-computer tijdens normaal gebruik met aarde is verbonden.

Varoitus

Tämä laitteisto on tarkoitettu maadoitettavaksi. Varmista, että isäntälaitte on yhdistetty maahan normaalikäytön aikana.

Attention

Cet équipement doit être relié à la terre. S'assurer que l'appareil hôte est relié à la terre lors de l'utilisation normale.

Warnung

Dieses Gerät muß geerdet werden. Stellen Sie sicher, daß das Host-Gerät während des normalen Betriebs an Erde gelegt ist.

Avvertenza

Questa apparecchiatura deve essere collegata a massa. Accertarsi che il dispositivo host sia collegato alla massa di terra durante il normale utilizzo.

Advarsel

Dette utstyret skal jordes. Forviss deg om vertsterminalen er jordet ved normalt bruk.

Aviso

Este equipamento deverá estar ligado à terra. Certifique-se que o host se encontra ligado à terra durante a sua utilização normal.

¡Advertencia!

Este equipo debe conectarse a tierra. Asegurarse de que el equipo principal esté conectado a tierra durante el uso normal.

Varning!

Denna utrustning är avsedd att jordas. Se till att värdenheten är jordad vid normal användning.

Figyelem

A készüléket védőföldeléssel kell ellátni. Győződjön meg róla, hogy a készülék normál használat során csatlakozik a földhöz.

Предупреждение

Данное устройство должно быть заземлено. Убедитесь, что при обычной работе устройство заземлено.

警告	此设备应该接地。请确保主机在正常使用期间连接接地。
警告	この装置はアースに接続するものです。通常の使用では、ホストがアース端子に接続されていることを確認してください。
주의	이 장비는 접지되어야 합니다. 사용 중에 호스트가 접지되어 있는 상태인지 반드시 확인하십시오.
Aviso	Este equipamento deve ser aterrado. Certifique-se de que o host esteja conectado ao fio terra durante o uso normal.
Upozornění	Toto zařízení by mělo být uzemněno. Zajistěte, aby byl hostitelský systém během běžného provozu uzemněn.
אזהרה	ציוד זה מיועד להיות מוארק. יש להבטיח שהמארך מחובר להארקה בעת שימוש רגיל.
Ostrzeżenie	Sprzęt ten powinien być uziemiony. Należy upewnić się, że podczas normalnego używania host jest podłączony do uziemienia.
Upozornenie	Toto zariadenie musí byť uzemnené. Počas normálneho používania zaistite, aby bolo hostiteľské zariadenie pripojené k uzemňovaciemu vodiču.
Opozorilo	Oprema mora biti ozemljena. Pazite, da je gostitelj med normalno uporabo povezan z ozemljitvijo.

Statement 43—Jewelry Removal Warning



Warning

Before working on equipment that is connected to power lines, remove jewelry (including rings, necklaces, and watches). Metal objects will heat up when connected to power and ground and can cause serious burns or weld the metal object to the terminals.

Waarschuwing

Alvorens aan apparatuur te werken die met elektrische leidingen is verbonden, sieraden (inclusief ringen, kettingen en horloges) verwijderen. Metalen voorwerpen worden warm wanneer ze met stroom en aarde zijn verbonden, en kunnen ernstige brandwonden veroorzaken of het metalen voorwerp aan de aansluitklemmen lassen.

Varoitus

Ennen kuin työskentelet voimavirtajohtoihin kytkettyjen laitteiden parissa, ota pois kaikki korut (sormukset, kaulakorut ja kellot mukaan lukien). Metalliesineet kuumenevat, kun ne ovat yhteydessä sähkövirran ja maan kanssa, ja ne voivat aiheuttaa vakavia palovammoja tai hitsata metalliesineet kiinni liitäntänapoihin.

Attention	Avant d'accéder à cet équipement connecté aux lignes électriques, ôter tout bijou (anneaux, colliers et montres compris). Lorsqu'ils sont branchés à l'alimentation et reliés à la terre, les objets métalliques chauffent, ce qui peut provoquer des blessures graves ou souder l'objet métallique aux bornes.
Warnung	Vor der Arbeit an Geräten, die an das Netz angeschlossen sind, jeglichen Schmuck (einschließlich Ringe, Ketten und Uhren) abnehmen. Metallgegenstände erhitzen sich, wenn sie an das Netz und die Erde angeschlossen werden, und können schwere Verbrennungen verursachen oder an die Anschlußklemmen angeschweißt werden.
Avvertenza	Prima di intervenire su apparecchiature collegate alle linee di alimentazione, togliersi qualsiasi monile (inclusi anelli, collane, braccialetti ed orologi). Gli oggetti metallici si riscaldano quando sono collegati tra punti di alimentazione e massa: possono causare ustioni gravi oppure il metallo può saldarsi ai terminali.
Advarsel	Fjern alle smykker (inkludert ringer, halskjeder og klokker) før du skal arbeide på utstyr som er koblet til kraftledninger. Metallgjenstander som er koblet til kraftledninger og jord blir svært varme og kan forårsake alvorlige brannskader eller smelte fast til polene.
Aviso	Antes de trabalhar em equipamento que esteja ligado a linhas de corrente, retire todas as jóias que estiver a usar (incluindo anéis, fios e relógios). Os objectos metálicos aquecerão em contacto com a corrente e em contacto com a ligação à terra, podendo causar queimaduras graves ou ficarem soldados aos terminais.
¡Advertencia!	Antes de operar sobre equipos conectados a líneas de alimentación, quitarse las joyas (incluidos anillos, collares y relojes). Los objetos de metal se calientan cuando se conectan a la alimentación y a tierra, lo que puede ocasionar quemaduras graves o que los objetos metálicos queden soldados a los bornes.
Varning!	Tag av alla smycken (inklusive ringar, halsband och armbandsur) innan du arbetar på utrustning som är kopplad till kraftledningar. Metallobjekt hettas upp när de kopplas ihop med ström och jord och kan förorsaka allvarliga brännskador; metallobjekt kan också sammansvetsas med kontakterna.
Figyelem	Mielőtt hálózati feszültséghez csatlakozó készülékkel kezd el dolgozni, vegye le magáról az ékszereket (például gyűrűt, nyakláncot, órát). A fém tárgyak felmelegszenek, ha hálózati feszültséghez és földhöz érnek, és súlyos égési sérülést okozhatnak, illetve a fém tárgyak hozzáforrhathatnak a csatlakozókhoz.
Предупреждение	Прежде чем использовать оборудование, подключенное к электросети, снимите все украшения (включая кольца, ожерелья и часы). Металлические части нагреваются при соединении с источником питания и землей, что может привести к серьезным ожогам или привариванию металлических объектов к клеммам.
警告	在操作与电源线连接的设备以前，请取下首饰（包括戒指、项链和手表）。连接电源和接地后，金属物品会升温，可能导致严重灼伤，也可能使金属物品熔接在线端。
警告	電源に接続されている装置を取り扱う際は、事前に、指輪、ネックレス、腕時計などの装身具をはずしてください。金属のオブジェクトが電源とアースと接触すると、金属が過熱して大やけどをしたり、また金属類が端子に焼き付くことがあります。

주의	전력선에 연결되어 있는 장비를 작동하기 전에, 장신구(반지, 목걸이 및 시계 포함)를 탈거하십시오. 전원에 연결되어 있고 접지되어 있을 때 금속체는 열을 받게 되어 심한 화상을 입을 수 있으며 이 금속체를 터미널에 접합시킬 수도 있습니다.
Aviso	Antes de trabalhar com equipamento conectado a cabos elétricos, tire suas jóias (incluindo anéis, pulseiras e relógios). Objetos de metal são aquecidos ao entrar em contato com a energia elétrica e o solo e podem causar queimaduras graves ou fazer com que o objeto de metal seja soldado nos terminais.
Upozornění	Před používáním zařízení připojeného k elektrické síti si sundejte klenoty a podobné předměty jako prsteny, řetízky či hodinky. Kovové předměty se při vytvoření elektrického obvodu mezi zdrojem a zemí mohou zahřát a způsobit vážné popáleniny či se přitavit k elektrické svorce.
Προειδοποίηση	Προτού εργαστείτε με εξοπλισμό που είναι συνδεδεμένος σε γραμμές τροφοδοσίας ρεύματος, αφαιρέστε τυχόν κοσμήματα (συμπεριλαμβανομένων δαχτυλιδιών, κολιέ και ρολογιών). Τα μεταλλικά αντικείμενα θερμαίνονται όταν εφάπτονται με πηγές τάσης και αγωγούς γείωσης και μπορούν να προκαλέσουν σοβαρά εγκαύματα ή να συγκολληθούν στους ακροδέκτες.
אזהרה	לפני עבודה על ציוד המחובר לקווי מתח, יש להסיר תכשיטים (כולל טבעות, שרשראות, ושעונים). עצמי מתכת יתחממו כאשר הם מחוברים למתח ולהארקה ועלולים לגרום לכוויות קשות או להלחים את חפץ המתכת להדקים.
Ostrzeżenie	Przed rozpoczęciem pracy na sprzęcie, który jest podłączony do linii pod napięciem, należy zdjąć biżuterię (łącznie z pierścionkami, naszyjnikami i zegarkami) Metalowe przedmioty ulegną nagrzananiu podczas połączenia (zwarcia) pomiędzy punktami pod napięciem i uziemieniem, co może spowodować poważne poparzenia lub przyspawanie metalowego przedmiotu do końcówek.
Upozornenie	Pred prácou na zariadení pripojenom k sieťovému napätiu si dajte dolu všetky šperky (vrátane prsteňov, náhrdelníkov a hodínok). Ak sa kovovými predmetmi prepojí časť pod napätím s uzemnenou časťou, kovové predmety sa zohrejú a môžu spôsobiť vážne popáleniny, alebo sa môžu privariť k svorkám.
Opozorilo	Pred uporabo opreme, ki je priključena na električno omrežje, snemite nakit (prstane, verižice in ure). Kovinski predmeti, ki so izpostavljeni elektriki in ozemljitvi, se segrejejo in lahko povzročijo hude opekline ali se stalijo na terminalih.
警告	操作已連接電源線的設備前，請移去首飾（包括戒指、項鍊和手錶）。金屬物件在與電源和地面連接時會加熱，並且可能導致嚴重灼傷或將金屬物件熔接到電極。

Statement 48—Stacking the Chassis Warning

Warning

Do not stack the chassis on any other equipment. If the chassis falls, it can cause severe bodily injury and equipment damage.

Waarschuwing

Het chassis mag niet op andere apparatuur gestapeld te worden. Als het chassis mocht vallen, kan dit ernstig lichamelijk letsel en beschadiging van de apparatuur veroorzaken.

Varoitus

Älä aseta asennuspohjaa minkään muun laitteen päälle. Asennuspohja voi pudotessaan aiheuttaa vaikean ruumiinvamman tai laitevaurion.

Attention

Ne placez pas ce châssis sur un autre appareil. En cas de chute, il pourrait provoquer de graves blessures corporelles et d'importants dommages.

Warnung

Das Gehäuse nicht auf andere Geräte stellen. Wenn das Gehäuse herunterfällt, besteht Gefahr schwerer Personenverletzungen und Geräteschäden.

Avvertenza

Non collocare lo chassis su nessun altro apparecchio. Se lo chassis cade, può causare lesioni gravi e danni alle apparecchiature.

Advarsel

Stable ikke kabinettet oppå annet utstyr. Hvis kabinettet faller, kan det forårsake alvorlig skade på mennesker og utstyr.

Aviso

Não coloque o chassis em cima de qualquer outro equipamento. Se o chassis cair, poderá causar ferimentos graves e danos no equipamento.

¡Atención!

No apilar los chasis sobre ningún otro equipo. Si el chasis se cae al suelo puede causar graves lesiones físicas y daños al equipo.

Varning

Placera inte chassit ovanpå annan utrustning. Om chassit faller kan allvarlig kroppsskada såväl som skada på utrustningen uppstå.

Figyelem

A készüléket ne tegye rá másik készülékre. Ha a készülék leesik, súlyos testi sérülést okozhat, és maga a készülék is megkárosodhat.

Предупреждение

Не устанавливайте данное устройство на любое другое оборудование. Если устройство упадет, то это может привести к тяжелым травмам и повреждению оборудования.

警告

不要将底盘堆放在其它任何设备上。如果底盘倒下，可能使身体受伤并损坏设备。

警告

別のいかなる装置の上にもシャーシを載せないでください。シャーシを落とすと、大けがをしたり装置を損傷させたりする場合があります。

Statement 171—Ethernet Cable Shielding in Offices



Warning

Ethernet cables must be shielded when used in a central office environment.

Waarschuwing

Ethernetkabels dienen beveiligd te worden als ze in een centrale kantooromgeving worden gebruikt.

Varoitus

Ethernet-kaapelit täytyy suojata, kun niitä käytetään yleisessä toimistoympäristössä.

Attention

Pour une utilisation en site central, les câbles Ethernet doivent être impérativement blindés.

Warnung

Ethernet-Kabel müssen abgeschirmt werden, wenn sie in einer Zentrale eingesetzt werden.

Avvertenza

I cavi Ethernet devono essere schermati se utilizzati in un ambiente di ufficio centrale.

Advarsel

Ethernet-kabler skal være skjernet når de brukes i et sentralt kontormiljø.

Aviso

Os cabos “Ethernet” deverão estar armados quando usados em ambiente de escritório central.

¡Advertencia!

Los cables Ethernet deben estar protegidos cuando se usen dentro de una oficina central.

Varning!

Ethernetkablar måste vara avskärmade vid användning i central kontorsmiljö.

Figyelem

Az Ethernet kábeleket árnyékolással kell ellátni, ha azokat helyi központban használják.

Предупреждение

Необходимо экранировать кабели Ethernet, используемые в офисе.

警告

在中心局环境中使用以太网电缆时，必须加以屏蔽。

警告

中央オフィス環境で使用される場合、イーサネットケーブルは遮蔽される必要があります。

주의

이더넷 케이블이 중앙식 사무 환경에서 사용될 경우 반드시 차폐되어야 합니다.

Aviso

Cabos Ethernet devem ser blindados quando usados em um ambiente de escritório.

Upozornění

Síťové kabely typu Ethernet musí být při používání v kancelářském prostředí stíněny.

אזהרה

יש לדאוג לסינוך כבלי Ethernet בעת שימוש בסביבת משרד מרכזי.

Ostrzeżenie

Kable sieci Ethernet muszą być ekranowane podczas używania ich w środowisku centralnego biura.

Upozornenie	Káble pre sieť Ethernet, ktoré sa používajú v kanceláriách, musia byť tienené.
Opozorilo	Kabli Ethernet morajo biti zaščiteni, kadar jih uporabljate v pisarniškem okolju.

Statement 258—Fan Tray Removal Warning



Warning

When removing the fan tray, keep your hands and fingers away from the spinning fan blades. Let the fan blades completely stop before you remove the fan tray.

Waarschuwing

Houd tijdens het verwijderen van de ventilator de handen en vingers uit de buurt van de draaiende ventilatorschoepen. Laat de ventilatorschoepen volledig tot stilstand komen alvorens de ventilator te verwijderen.

Varoitus

Pidä kädet ja sormet pois tuulettimen pyörivistä siivistä tuuletinalustaa poistaessasi. Anna tuulettimen siipien pysähtyä kokonaan ennen kuin irrotat tuuletinalustan.

Attention

Lors du retrait du plateau du ventilateur, veillez à ce que vos mains et doigts restent à l'écart des pales en rotation du ventilateur. Attendez que les pales du ventilateur soient parvenues à une immobilité complète avant de retirer le plateau du ventilateur.

Warnung

Beim Herausnehmen des Lüfterkastens Hände und Finger von den sich drehenden Gebläseflügeln fern halten. Vor Herausnehmen des Gebläsekastens warten, bis die Gebläseflügel völlig zum Stillstand gekommen sind.

Avvertenza

Quando si toglie il vano della ventola, fare attenzione che le mani e le dita non vengano in contatto con la ventola in movimento. Attendere che la ventola si fermi completamente prima di togliere il vano.

Advarsel

Når du fjerner viftedekselet, hold hender og fingre borte fra de roterende viftebladene. La viftebladene stanse helt før du fjerner viftedekselet.

Aviso

Mantenha as suas mãos e dedos afastados das lâminas em movimento da ventoinha, ao retirar a respectiva bandeja. Deixe as lâminas da ventoinha parar completamente antes de retirar a bandeja.

¡Advertencia!

Cuando quite la bandeja del abanico, mantenga las manos y los dedos alejados de las aspas en movimiento. Deje que las aspas se detengan completamente antes de quitar la bandeja del abanico.

Varning!

Håll händer och fingrar borta från de roterande fläktbladen när du tar av fläktskyddet. Låt fläkten stanna helt innan du tar av fläktskyddet.

Figyelem

Ha eltávolítva a ventilátor borítóját, ügyeljen rá, hogy ne tegye kezét vagy ujjait a ventilátor forgó lapátjai közelébe. A ventilátor borítójának eltávolítása előtt várja meg, hogy a ventilátor lapátjai teljesen megálljanak.

Предупреждение	При снятии вентиляторного блока не подносите руки близко к вращающимся лопастям вентилятора. Перед снятием вентиляторного блока дождитесь полной остановки лопастей вентилятора.
警告	在拆卸风扇架时，手和手指不要碰到旋转着的风扇叶片。待风扇叶片完全停止旋转后再拆卸风扇架。
警告	ファントレイを取り外すときは、回転しているファンブレードに手や指が触れないように注意してください。ファンブレードが完全に静止してから、ファントレイを取り外してください。

Statement 322—DC Power Off Warning



Warning

Before performing any of the following procedures, ensure that power is removed from the DC circuits. To ensure that all power is removed, locate the circuit breakers or fuses on the DC power lines that service the DC circuits. Turn OFF the DC power line circuit breakers and remove the DC power line fuses.

Waarschuwing

Zorg dat de stroom van de gelijkstroomcircuits is verwijderd voordat u een van de volgende procedures verricht. Zoek naar de stroomonderbrekers of zekeringen op de wisselstroomleidingen die stroom leveren naar de gelijkstroomcircuits om te zorgen dat alle stroom verwijderd is. Zet de stroomonderbrekers van de gelijkstroomleiding UIT en verwijder de zekeringen van de gelijkstroomleiding.

Varoitus

Ennen kuin suoritat mitään seuraavista toimenpiteistä, varmista, ettei tasasähköpiireissä ole virtaa. Varmista virrattomuus etsimällä tasasähköpiireihin tulevissa tasasähkölinjoissa olevat virrankatkaisimet tai sulakkeet. Käännä tasasähkölinjan virrankatkaisimet POIS PÄÄLTÄ ja irrota tasasähkölinjan sulakkeet.

Attention

Avant d'effectuer l'une des procédures suivantes, veillez à interrompre l'alimentation électrique des circuits de cc. Pour vérifier que tout le courant est bien désactivé, identifiez les coupe-circuits ou fusibles des lignes d'alimentation en cc qui desservent les circuits cc. Désactivez (position OFF) les coupe-circuits de la ligne d'alimentation en cc, puis retirez les fusibles de la ligne d'alimentation en cc.

Warnung

Stellen Sie sicher, dass an den Gleichstromkreisen kein Strom anliegt, bevor Sie einen der folgenden Vorgänge durchführen. Ermitteln Sie die Schutzschalter oder Sicherungen an den Gleichstromleitungen, die die Gleichstromkreise beliefern, um sicherzugehen, dass kein Strom mehr anliegt. Schalten Sie die Schutzschalter der Gleichstromleitungen AUS, und entfernen Sie die Sicherungen aus der Gleichstromleitung.

Avvertenza

Prima di eseguire una delle procedure seguenti, assicurarsi di aver disattivato l'alimentazione dei circuiti CC. A questo scopo, individuare gli interruttori automatici o i fusibili sulle linee di alimentazione CC che alimentano i circuiti CC. Disattivare gli interruttori automatici e rimuovere i fusibili delle linee di alimentazione CC.

Advarsel	Før du foretar noen av følgende prosedyrer må du påse at strømmen er fjernet fra likestrømkretsene. For å være sikkert på at all strøm er fjernet, finn vernebryterne eller sikringene på likestrømlinjene som går til likestrømkretsene. Slå AV vernebryteren for likestrømlinjen og fjern linjesikringene for likestrøm.
Aviso	Antes de executar qualquer dos procedimentos a seguir, assegure que a energia esteja removida dos circuitos CC. Para assegurar que toda a energia está removida, localize os disjuntores ou fusíveis nas linhas de energia CC que servem os circuitos CC. DESLIGUE os disjuntores da linha de energia CC e remova os fusíveis dessa linha.
¡Advertencia!	Antes de llevar a cabo cualquiera de los siguientes procedimientos, asegúrese de que los circuitos de CC no reciban alimentación eléctrica. Para estar seguro de que se ha retirado toda la alimentación eléctrica, localice los disyuntores o fusibles de las líneas de CC que alimentan los circuitos de CC. Coloque los disyuntores de la línea de alimentación de CC en posición de apagado (OFF) y retire los fusibles de la línea de alimentación de CC.
Varning!	Innan någon av följande åtgärder utförs ska man se till att strömmen är bortkopplad från likströmskretsarna. För att se till att all ström är bortkopplad, leta reda på brytarna eller säkringarna på likströmskablar som leder till likströmskretsarna. Slå AV likströmsledningens brytare och ta bort likströmsledningens säkringar.

Statement 1001—Work During Lightning Activity



Warning

Do not work on the system or connect or disconnect cables during periods of lightning activity.

Waarschuwing

Tijdens onweer dat gepaard gaat met bliksem, dient u niet aan het systeem te werken of kabels aan te sluiten of te ontkoppelen.

Varoitus

Älä työskentele järjestelmän parissa äläkä yhdistä tai irrota kaapeleita ukkosilmalla.

Attention

Ne pas travailler sur le système ni brancher ou débrancher les câbles pendant un orage.

Warnung

Arbeiten Sie nicht am System und schließen Sie keine Kabel an bzw. trennen Sie keine ab, wenn es gewittert.

Avvertenza

Non lavorare sul sistema o collegare oppure scollegare i cavi durante un temporale con fulmini.

Advarsel

Utfør aldri arbeid på systemet, eller koble kabler til eller fra systemet når det tordner eller lyner.

Aviso

Não trabalhe no sistema ou ligue e desligue cabos durante períodos de mau tempo (trovoada).

¡Advertencia!

No operar el sistema ni conectar o desconectar cables durante el transcurso de descargas eléctricas en la atmósfera.

Varning!

Vid åska skall du aldrig utföra arbete på systemet eller ansluta eller koppla loss kablar.

Figyelem	Villámítás közben ne dolgozzon a rendszeren, valamint ne csatlakoztasson és ne húzzon ki kábeleket!
Предупреждение	Не следует работать с устройством, а также подключать или отключать кабели во время грозы.
警告	请勿在发生雷电时操作系统，也不要在此期间连接或断开电缆。
警告	雷が発生しているときは、システムに手を加えたり、ケーブルの接続や取り外しを行わないでください。

Statement 1003—DC Power Disconnection



Warning	Before performing any of the following procedures, ensure that power is removed from the DC circuit.
Waarschuwing	Voordat u een van de onderstaande procedures uitvoert, dient u te controleren of de stroom naar het gelijkstroom circuit uitgeschakeld is.
Varoitus	Varmista, että tasavirtapiirissä ei ole virtaa ennen seuraavien toimenpiteiden suorittamista.
Attention	Avant de pratiquer l'une quelconque des procédures ci-dessous, vérifier que le circuit en courant continu n'est plus sous tension.
Warnung	Vor Ausführung der folgenden Vorgänge ist sicherzustellen, daß die Gleichstromschaltung keinen Strom erhält.
Avvertenza	Prima di svolgere una qualsiasi delle procedure seguenti, verificare che il circuito CC non sia alimentato.
Advarsel	Før noen av disse prosedyrene utføres, kontroller at strømmen er frakoblet likestrømkretsen.
Aviso	Antes de executar um dos seguintes procedimentos, certifique-se que desligou a fonte de alimentação de energia do circuito de corrente contínua.
¡Advertencia!	Antes de proceder con los siguientes pasos, comprobar que la alimentación del circuito de corriente continua (CC) esté cortada (OFF).
Varning!	Innan du utför någon av följande procedurer måste du kontrollera att strömförsörjningen till likströmskretsen är bruten.
Figyelem	Mielőtt a következő eljárások bármelyikét végrehajtaná, feltétlenül szakítsa meg az egyenáramú áramkör tápellátását.

Предупреждение	Перед выполнением любых описанных ниже действий убедитесь, что цепь питания постоянным током отключена.
警告	在进行下述任一操作过程之前，要确保将电源从直流电路上断开。
警告	次の手順を開始する前に、DC回路から電源が切断されていることを確認してください。
주의	다음 작업을 진행하기 전에, 직류 회로에서 전원이 차단되었는지 확인하십시오.
Aviso	Antes de executar qualquer um dos procedimentos a seguir, verifique se a energia foi removida do circuito DC.
Advarsel	Før du udfører nogen af følgende procedurer, skal du sikre dig, at der ikke er strøm til jævnstrømskredsløbet.
تحذير	قبل القيام بأي من الإجراءات التالية، تأكد من فصل التيار من دائرة التيار المباشر.
Upozorenje	Prije obavljanja nekog od sljedećih postupaka, provjerite da u krugovima s istosmjernom strujom nema napajanja.
Upozornění	Před provedením kterékoliv z následujících operací odpojte napájení od stejnosměrného obvodu.
Προειδοποίηση	Πριν να ακολουθήσετε οποιαδήποτε από τις παρακάτω διαδικασίες, βεβαιωθείτε ότι έχει διακοπεί η τροφοδοσία από το κύκλωμα συνεχούς ρεύματος.
אזהרה	לפני ביצוע אחד מהנהלים הבאים, ודא שאספקת החשמל למעגל הזרם הישר (DC) מנותקת.
	Пред вршење на која и да е од следните постапки, погрижете се да нема напојување на струјните кола со едновременна струја.
Ostrzeżenie	Przed przystąpieniem do wykonywania poniższych procedur należy upewnić się, że odłączono zasilanie od obwodu prądu stałego.
Upozornenie	Pred vykonaním ktorejkoľvek z nasledujúcich operácií odpojte napájanie od jednosmerného obvodu.

Statement 1004—Installation Instructions



Warning

Read the installation instructions before connecting the system to the power source.

Waarschuwing

Raadpleeg de installatie-instructies voordat u het systeem op de voedingsbron aansluit.

Varoitus

Lue asennusohjeet ennen järjestelmän yhdistämistä virtalähteeseen.

Attention

Avant de brancher le système sur la source d'alimentation, consulter les directives d'installation.

Warnung

Vor dem Anschließen des Systems an die Stromquelle die Installationsanweisungen lesen.

Avvertenza

Consultare le istruzioni di installazione prima di collegare il sistema all'alimentatore.

Advarsel

Les installasjonsinstruksjonene før systemet kobles til strømkilden.

Aviso

Leia as instruções de instalação antes de ligar o sistema à fonte de energia.

¡Advertencia!

Lea las instrucciones de instalación antes de conectar el sistema a la red de alimentación.

Varning!

Läs installationsanvisningarna innan du kopplar systemet till strömförsörjningsenheten.

Figyelem

Mielőtt áramforráshoz csatlakoztatná a rendszert, olvassa el az üzembe helyezési útmutatót!

Предупреждение

Перед подключением устройства к источнику электропитания ознакомьтесь с данной инструкцией по установке.

警告

在将系统与电源连接之前，请仔细阅读安装说明。

警告

必ず設置手順を読んでから、システムを電源に接続してください。

Upozorenje

Prije obavljanja nekog od sljedećih postupaka, provjerite da u krugovima s istosmjernom strujom nema napajanja.

Upozornění

Před provedením kterékoliv z následujících operací odpojte napájení od stejnosměrného obvodu.

Προειδοποίηση	Πριν να ακολουθήσετε οποιαδήποτε από τις παρακάτω διαδικασίες, βεβαιωθείτε ότι έχει διακοπεί η τροφοδοσία από το κύκλωμα συνεχούς ρεύματος.
אזהרה	לפני ביצוע אחד מהנהלים הבאים, ודא שאפסקת החשמל למעגל הזרם הישר (DC) מנותקת.
Опoмeнa	Пред вршење на која и да е од следните постапки, погрижете се да нема напојување на струјните кола со едновременна струја.
Ostrzeżenie	Przed przystąpieniem do wykonywania poniższych procedur należy upewnić się, że odłączono zasilanie od obwodu prądu stałego.
Upozornenie	Pred vykonaním ktorejkoľvek z nasledujúcich operácií odpojte napájanie od jednosmerného obvodu.

Statement 1006—Chassis Warning for Rack-Mounting and Servicing



Warning

To prevent bodily injury when mounting or servicing this unit in a rack, you must take special precautions to ensure that the system remains stable. The following guidelines are provided to ensure your safety:

- This unit should be mounted at the bottom of the rack if it is the only unit in the rack.
- When mounting this unit in a partially filled rack, load the rack from the bottom to the top with the heaviest component at the bottom of the rack.
- If the rack is provided with stabilizing devices, install the stabilizers before mounting or servicing the unit in the rack.

Waarschuwing

Om lichamelijk letsel te voorkomen wanneer u dit toestel in een rek monteert of het daar een servicebeurt geeft, moet u speciale voorzorgsmaatregelen nemen om ervoor te zorgen dat het toestel stabiel blijft. De onderstaande richtlijnen worden verstrekt om uw veiligheid te verzekeren:

- Dit toestel dient onderaan in het rek gemonteerd te worden als het toestel het enige in het rek is.
- Wanneer u dit toestel in een gedeeltelijk gevuld rek monteert, dient u het rek van onderen naar boven te laden met het zwaarste onderdeel onderaan in het rek.
- Als het rek voorzien is van stabiliseringshulpmiddelen, dient u de stabilisatoren te monteren voordat u het toestel in het rek monteert of het daar een servicebeurt geeft.

Varoitus	<p>Kun laite asetetaan telineeseen tai huolletaan sen ollessa telineessä, on noudatettava erityisiä varotoimia järjestelmän vakavuuden säilyttämiseksi, jotta vältetään loukkaantumiselta. Noudata seuraavia turvallisuusohjeita:</p> <ul style="list-style-type: none">• Jos telineessä ei ole muita laitteita, aseta laite telineen alaosaan.• Jos laite asetetaan osaksi täytettyyn telineeseen, aloita kuormittaminen sen alaosasta kaikkein raskaimmalla esineellä ja siirry sitten sen yläosaan.• Jos telinettä varten on vakaimet, asenna ne ennen laitteen asettamista telineeseen tai sen huoltamista siinä.
Attention	<p>Pour éviter toute blessure corporelle pendant les opérations de montage ou de réparation de cette unité en casier, il convient de prendre des précautions spéciales afin de maintenir la stabilité du système. Les directives ci-dessous sont destinées à assurer la protection du personnel:</p> <ul style="list-style-type: none">• Si cette unité constitue la seule unité montée en casier, elle doit être placée dans le bas.• Si cette unité est montée dans un casier partiellement rempli, charger le casier de bas en haut en plaçant l'élément le plus lourd dans le bas.• Si le casier est équipé de dispositifs stabilisateurs, installer les stabilisateurs avant de monter ou de réparer l'unité en casier.
Warnung	<p>Zur Vermeidung von Körperverletzung beim Anbringen oder Warten dieser Einheit in einem Gestell müssen Sie besondere Vorkehrungen treffen, um sicherzustellen, daß das System stabil bleibt. Die folgenden Richtlinien sollen zur Gewährleistung Ihrer Sicherheit dienen:</p> <ul style="list-style-type: none">• Wenn diese Einheit die einzige im Gestell ist, sollte sie unten im Gestell angebracht werden.• Bei Anbringung dieser Einheit in einem zum Teil gefüllten Gestell ist das Gestell von unten nach oben zu laden, wobei das schwerste Bauteil unten im Gestell anzubringen ist.• Wird das Gestell mit Stabilisierungszubehör geliefert, sind zuerst die Stabilisatoren zu installieren, bevor Sie die Einheit im Gestell anbringen oder sie warten.
Avvertenza	<p>Per evitare infortuni fisici durante il montaggio o la manutenzione di questa unità in un supporto, occorre osservare speciali precauzioni per garantire che il sistema rimanga stabile. Le seguenti direttive vengono fornite per garantire la sicurezza personale:</p> <ul style="list-style-type: none">• Questa unità deve venire montata sul fondo del supporto, se si tratta dell'unica unità da montare nel supporto.• Quando questa unità viene montata in un supporto parzialmente pieno, caricare il supporto dal basso all'alto, con il componente più pesante sistemato sul fondo del supporto.• Se il supporto è dotato di dispositivi stabilizzanti, installare tali dispositivi prima di montare o di procedere alla manutenzione dell'unità nel supporto.
Advarsel	<p>Unngå fysiske skader under montering eller reparasjonsarbeid på denne enheten når den befinner seg i et kabinett. Vær nøye med at systemet er stabilt. Følgende retningslinjer er gitt for å verne om sikkerheten:</p> <ul style="list-style-type: none">• Denne enheten bør monteres nederst i kabinettet hvis dette er den eneste enheten i kabinettet.• Ved montering av denne enheten i et kabinett som er delvis fylt, skal kabinettet lastes fra bunnen og opp med den tyngste komponenten nederst i kabinettet.• Hvis kabinettet er utstyrt med stabiliseringsutstyr, skal stabilisatorene installeres før montering eller utføring av reparasjonsarbeid på enheten i kabinettet.

Aviso Para se prevenir contra danos corporais ao montar ou reparar esta unidade numa estante, deverá tomar precauções especiais para se certificar de que o sistema possui um suporte estável. As seguintes directrizes ajudá-lo-ão a efectuar o seu trabalho com segurança:

- Esta unidade deverá ser montada na parte inferior da estante, caso seja esta a única unidade a ser montada.
- Ao montar esta unidade numa estante parcialmente ocupada, coloque os itens mais pesados na parte inferior da estante, arrumando-os de baixo para cima.
- Se a estante possuir um dispositivo de estabilização, instale-o antes de montar ou reparar a unidade.

¡Advertencia! Para evitar lesiones durante el montaje de este equipo sobre un bastidor, o posteriormente durante su mantenimiento, se debe poner mucho cuidado en que el sistema quede bien estable. Para garantizar su seguridad, proceda según las siguientes instrucciones:

- Colocar el equipo en la parte inferior del bastidor, cuando sea la única unidad en el mismo.
- Cuando este equipo se vaya a instalar en un bastidor parcialmente ocupado, comenzar la instalación desde la parte inferior hacia la superior colocando el equipo más pesado en la parte inferior.
- Si el bastidor dispone de dispositivos estabilizadores, instalar éstos antes de montar o proceder al mantenimiento del equipo instalado en el bastidor.

Varning! För att undvika kroppsskada när du installerar eller utför underhållsarbete på denna enhet på en ställning måste du vidta särskilda försiktighetsåtgärder för att försäkra dig om att systemet står stadigt. Följande riktlinjer ges för att trygga din säkerhet:

- Om denna enhet är den enda enheten på ställningen skall den installeras längst ned på ställningen.
- Om denna enhet installeras på en delvis fylld ställning skall ställningen fyllas nedifrån och upp, med de tyngsta enheterna längst ned på ställningen.
- Om ställningen är försedd med stabiliseringsdon skall dessa monteras fast innan enheten installeras eller underhålls på ställningen.

Figyelem A készülék rackbe történő beszerelése és karbantartása során bekövetkező sérülések elkerülése végett speciális óvintézkedésekkel meg kell őrizni a rendszer stabilitását. A személyes biztonsága érdekében tartsa be a következő szabályokat:

- Ha a rackben csak ez az egy készülék található, a rack aljába kell beszerelni.
- Ha nincs teljesen tele az a rack, amelybe beszerelik a készüléket, alulról fölfelé haladva töltsse fel a racket úgy, hogy a legnehezebb készülék kerüljön a rack aljába.
- Ha stabilizáló eszközök is tartoznak a rackhez, szerelje fel a stabilizátorokat, mielőtt beszerelné az egységet a rackbe, vagy karbantartást végezne rajta.

Предупреждение Во избежание травм при монтаже и обслуживании устройства в стойке следует принять особые меры предосторожности, чтобы убедиться в устойчивости оборудования. Для обеспечения безопасности работ необходимо соблюдать следующие правила.

- Если в стойке находится одно устройство, оно должно быть установлено в нижней части.
- При монтаже устройств в частично заполненную стойку устанавливайте оборудование снизу вверх, размещая наиболее тяжелые устройства в нижней части.
- Если стойка снабжена приспособлениями для стабилизации, их необходимо установить до начала монтажа или обслуживания оборудования.

- 警告** 为避免在机架中安装或维修该部件时使身体受伤，您必须采取特殊的预防措施确保系统固定。以下是确保安全的原则：
- 如果此部件是机架中唯一的部件，应将其安装在机架的底部。
 - 如果在部分装满的机架中安装此部件，请按从下往上的顺序安装各个部件，并且最重的组件应安装在机架的底部。
 - 如果机架配有固定装置，请先装好固定装置，然后再在机架中安装或维修部件。
- 警告** この装置をラックに設置したり保守作業を行ったりするときは、人身事故を防ぐため、システムが安定しているかどうかを十分に確認する必要があります。次の注意事項に従ってください。
- ラックにこの装置を単独で設置する場合は、ラックの一番下に設置します。
 - ラックに別の装置がすでに設置されている場合は、最も重量のある装置を一番下にして、重い順に下から上へ設置します。
 - ラックに安定器具が付属している場合は、その安定器具を取り付けてから、装置をラックに設置するか、またはラック内の装置の保守作業を行ってください。
- 주의** 이 장치를 랙에 장착하거나 서비스할 때 신체 부상을 방지하려면, 시스템이 안정된 상태를 유지하도록 특별히 주의해야 합니다. 사용자의 안전을 위해 다음 지침 사항을 준수하십시오.
- 이 장치가 랙에 장착되는 유일한 것일 경우, 랙의 맨 아래 부분에 장착되어야 합니다.
 - 부분적으로 차 있는 랙에 이 장치를 장착할 경우, 가장 무거운 장치를 랙의 맨 아래 부분부터 차례로 장착하십시오.
 - 안정기가 랙과 함께 제공되는 경우, 이 안정기를 설치한 후 이 장치를 랙에 장착하거나 서비스하십시오.
- Aviso** **Para evitar lesões corporais ao montar ou dar manutenção a esta unidade em um rack, é necessário tomar todas as precauções para garantir a estabilidade do sistema. As seguintes orientações são fornecidas para garantir a sua segurança:**
- **Se esta for a única unidade, ela deverá ser montada na parte inferior do rack.**
 - **Ao montar esta unidade em um rack parcialmente preenchido, carregue-o de baixo para cima com o componente mais pesado em sua parte inferior.**
 - **Se o rack contiver dispositivos estabilizadores, instale-os antes de montar ou dar manutenção à unidade existente.**
- Advarsel** **For at forhindre legemesbeskadigelse ved montering eller service af denne enhed i et rack, skal du sikre at systemet står stabilt. Følgende retningslinjer er også for din sikkerheds skyld:**
- **Enheden skal monteres i bunden af dit rack, hvis det er den eneste enhed i racket.**
 - **Ved montering af denne enhed i et delvist fyldt rack, skal enhederne installeres fra bunden og opad med den tungeste enhed nederst.**
 - **Hvis racket leveres med stabiliseringsenheder, skal disse installeres for enheden monteres eller serviceres i racket.**

تحذير	<p>لتجنب حدوث أي إصابات عند تركيب هذه الوحدة، يجب اتباع بعض الاحتياطات لضمان عمل النظام بشكل سليم. يتم ذكر الإرشادات التالية لضمان الأمان.</p> <p>يجب تركيب هذه الوحدة في الجزء السفلي من الدولاب المتضمن قضبان إذا كانت هذه الوحدة هي الوحدة الوحيدة في الدولاب الذي يحتوي على قضبان.</p> <p>عند تركيب هذه الوحدة في دولاب شبه ممتلئ، قم برفع الدولاب من الجزء السفلي لأعلى بحيث يكون الجزء الأثقل وزناً أسفل الدولاب.</p> <p>إذا كان الدولاب المتضمن قضباناً يحتوي على أجهزة حفظ التوازن، قم بتثبيت هذه الأجهزة قبل تركيب الوحدة في الدولاب.</p>
Upozorenje	<p>Kako ne bi došlo do tjelesnih ozljeda kod postavljanja ili servisiranja uređaja na polici, potrebno je poduzeti mjere predostrožnosti kako bi sustav uvijek bio stabilan. Sigurnost se može osigurati poštivanjem sljedećih smjernica:</p> <ul style="list-style-type: none"> • Ovaj uređaj treba ugraditi na dno police, ukoliko je to jedini uređaj na polici. • Kod ugradnje uređaja u policu na kojoj se već nalaze drugi uređaji, policu treba opremiti počevši od dna, te tako da se na dno stave najteži dijelovi. • Ukoliko su na polici ugrađeni stabilizatori, njih montirajte prije ugradnje ili servisiranja uređaja na polici.
Upozornění	<p>Abyste předešli poranění osob při montáži nebo opravě zařízení v montážním rámu, musíte dodržovat zvláštní preventivní opatření pro zajištění udržení stability systému. Pro zajištění bezpečnosti obsluhy jsou určeny následující zásady:</p> <ul style="list-style-type: none"> • Pokud je toto zařízení jedinou jednotkou v montážním rámu, musí být namontováno na nejnižší místo rámu. • Pokud je toto zařízení montováno do částečně obsazeného montážního rámu, obsazujte montážní rám ve směru zdola nahoru tak, aby byla nejtěžší součást nejnižší. • Pokud je montážní rám vybaven stabilizačními zařízeními, nainstalujte stabilizátory ještě před montáží nebo opravou zařízení v montážním rámu.
Προειδοποίηση	<p>Για να αποφύγετε τον τραυματισμό κατά την τοποθέτηση ή τη συντήρηση αυτής της συσκευής σε αρθρωτό σύστημα, πρέπει να λάβετε ειδικές προφυλάξεις για να διασφαλίσετε τη σταθερότητα του συστήματος. Οι παρακάτω οδηγίες παρέχονται για να εξασφαλίσουν την ασφάλειά σας:</p> <ul style="list-style-type: none"> • Αυτή η συσκευή πρέπει να τοποθετείται στο κάτω μέρος του αρθρωτού συστήματος αν είναι η μοναδική συσκευή σε αυτό. • Όταν τοποθετείτε αυτήν τη συσκευή σε εν μέρει γεμάτο αρθρωτό σύστημα, τοποθετήστε συσκευές στο αρθρωτό σύστημα από κάτω προς τα επάνω, με τη βαρύτερη συσκευή στο κάτω μέρος του συστήματος. • Εάν το αρθρωτό σύστημα διαθέτει διατάξεις σταθεροποίησης, τοποθετήστε τους σταθεροποιητές πριν τοποθετήσετε ή συντηρήσετε τη συσκευή στο αρθρωτό σύστημα.

אזהרה	<p>כדי למנוע פציעה בעת הרכבת יחידה זו במעמד או טיפול בה, עליך לנקוט אמצעי זהירות מיוחדים כדי להבטיח את יציבות המערכת. הקווים המנחים הבאים ניתנים על מנת להבטיח את ביטחונך:</p> <ul style="list-style-type: none"> • אם יחידה זו היא יחידה בודדת במעמד, יש להרכיב את היחידה בחלקו התחתון של המעמד. • בעת הרכבת יחידה זו במעמד המלא בחלקו, טען את המעמד החל בחלק התחתון וכלפי מעלה כאשר הרכיב הכבד ביותר נמצא בחלקו התחתון של המעמד. • אם המעמד מסופק עם התקני ייצוב, התקן את המייצבים לפני הרכבה היחידה במעמד או טיפול בה. <p>За да се не повредите кога го монтирате или го сервисирате уредот на полица, мора да бидете особено претпазливи за да ја обезбедите стабилноста на системот. Следите напатствија се дадени за да ја осигураат Вашата безбедност:</p> <ul style="list-style-type: none"> • Уредот треба да се монтира најдолу на полицата ако е единствен уред на полицата. • Кога го монтирате уредот на делумно пополнета полица, полнете ја полицата од дното кон врвот со најтешката компонента на дното на полицата. • Ако полицата има стабилизаторски делови, наместете ги стабилизаторите пред да го монтирате или сервисирате уредот на полицата.
Ostrzeżenie	<p>Aby zapobiec urazom podczas montażu lub serwisowania tego urządzenia w stojaku, należy zastosować szczególne środki ostrożności w celu zapewnienia stabilności układu. Poniżej przedstawiono wskazówki, których przestrzeganie zapewni bezpieczeństwo:</p> <ul style="list-style-type: none"> • Jeśli urządzenie to jest jedynym urządzeniem w stojaku, powinno być zamontowane na dole. • W przypadku montażu urządzenia w częściowo zapełnionym stojaku należy instalować kolejne urządzenia od najniższego do najwyższego, przy czym element najcięższy powinien być zamontowany najniżej w stojaku. • Jeśli stojak jest wyposażony w elementy stabilizujące, należy zamontować stabilizatory przed przystąpieniem do montażu lub serwisowania urządzeń w stojaku.
Upozornenie	<p>Aby ste predišli poraneniu osôb pri montáži alebo oprave zariadenia v montážnom ráme, musíte dodržiavať zvláštne preventívne opatrenia na zaistenie udržania stability systému. Na zaistenie bezpečnosti obsluhy sú určené nasledujúce zásady:</p> <ul style="list-style-type: none"> • Pokiaľ je toto zariadenie jedinou jednotkou v montážnom ráme, musí byť namontované na najnižšie miesto v ráme. • Pokiaľ je toto zariadenie montované do čiastočne obsadeného montážneho rámu, obsadzujte montážny rám v smere zdola nahor tak, aby bola najťažšia súčasť najnižšie. • Pokiaľ je montážny rám vybavený stabilizačnými zariadeniami, nainštalujte stabilizátory ešte pred montážou alebo opravou zariadenia v montážnom ráme.
警告	<p>在機架上裝載或維修本裝置時，為避免人身傷害，請務必採取特殊措施以確保系統保持穩固。下列指導方針為確保您的安全而提供：</p> <ul style="list-style-type: none"> • 如果只在機架上裝載一個裝置，必須裝載在機架底部。 • 如果機架上已經裝載其他裝置，請從底到頂依序裝載最重到最輕的裝置。 • 如果機架附有穩定設備，請先安裝該設備，再於機架上裝載或維修裝置。

Statement 1008—Class 1 Laser Product



Warning	Class 1 laser product.
Waarschuwing	Klasse-1 laser produkt.
Varoitus	Luokan 1 lasertuote.
Attention	Produit laser de classe 1.
Warnung	Laserprodukt der Klasse 1.
Avvertenza	Prodotto laser di Classe 1.
Advarsel	Laserprodukt av klasse 1.
Aviso	Produto laser de classe 1.
¡Advertencia!	Producto láser Clase I.
Varning!	Laserprodukt av klass 1.
Aviso	Produto a laser de classe 1.
Advarsel	Klasse 1 laserprodukt.
Figyelem	Class 1 besorolású lézeres termék.
Предупреждение	Лазерное устройство класса 1.
警告	这是 1 类激光产品。
警告	クラス1レーザー製品です。
주의	클래스 1 레이저 제품.
تحذير	Class 1 Laser منتج ١
Upozorenje	Laserski proizvod klase 1
Upozornění	Laserový výrobek třídy 1.

Προειδοποίηση	Προϊόν λέιζερ κατηγορίας 1.
אזהרה	מוצר לייזר Class 1.
Opomena	Ласерски производ од класа 1.
Ostrzeżenie	Produkt laserowy klasy 1.
Upozornenie	Laserový výrobok triedy 1.

Statement 1017—Restricted Area



Warning

This unit is intended for installation in restricted access areas. A restricted access area can be accessed only through the use of a special tool, lock and key, or other means of security.

Waarschuwing

Deze eenheid is bestemd voor installatie in plaatsen met beperkte toegang. Toegang tot een dergelijke plaats kan alleen verkregen worden door middel van een speciaal instrument, een slot en sleutel of een ander veiligheidsmiddel.

Varoitus

Tämä laite on tarkoitettu asennettavaksi paikkaan, johon pääsy on rajoitettua. Tällaiseen paikkaan pääsee vain erikoistyökäluu, lukkoon sopivaa avainta tai jotakin muuta turvalaitetta käyttämällä.

Attention

Cet appareil est à installer dans des zones d'accès réservé. L'accès à une zone d'accès réservé n'est possible qu'en utilisant un outil spécial, un mécanisme de verrouillage et une clé, ou tout autre moyen de sécurité.

Warnung

Diese Einheit ist zur Installation in Bereichen mit beschränktem Zutritt vorgesehen. Der Zutritt zu derartigen Bereichen ist nur mit einem Spezialwerkzeug, Schloss und Schlüssel oder einer sonstigen Sicherheitsvorkehrung möglich.

Avvertenza

Questa unità è prevista per essere installata in un'area ad accesso limitato, vale a dire un'area accessibile solo mediante l'uso di un attrezzo speciale, come lucchetto e chiave, o altri dispositivi di sicurezza.

Advarsel

Denne enheten er beregnet på installasjon i områder med begrenset tilgang. Et begrenset tilgangsområde kan bare nås ved hjelp av et spesielt verktøy, lås og nøkkel, eller andre sikkerhetsanordninger.

Aviso

Esta unidade foi concebida para instalação em áreas de acesso restrito. Uma área de acesso restrito é uma área à qual apenas tem acesso o pessoal de serviço autorizado, que possua uma ferramenta, chave e fechadura especial, ou qualquer outra forma de segurança.

¡Advertencia!	Esta unidad ha sido diseñada para instalación en áreas de acceso restringido. Sólo puede obtenerse acceso a una de estas áreas mediante la utilización de una herramienta especial, cerradura con llave u otro medio de seguridad.
Varning!	Denna enhet är avsedd för installation i områden med begränsat tillträde. Ett område med begränsat tillträde kan endast tillträdas med hjälp av specialverktyg, lås och nyckel eller annan säkerhetsanordning.
Figyelem	A készülék korlátozottan hozzáférhető területre történő beszerelésre készült. A korlátozottan hozzáférhető területekhez csak speciális szerszám, zár és kulcs vagy más biztonsági berendezés segítségével lehet hozzáférni.
Предупреждение	Данное устройство предназначено для установки в помещениях с ограниченным доступом. В такие помещения можно попасть, только имея специальное устройство доступа, карту или ключ или пройдя проверку другими средствами обеспечения безопасности.
警告	此部件应安装在限制进出的场所。限制进出的场所指只能通过使用特殊工具、锁和钥匙或其它安全手段进出的场所。
警告	この装置は立ち入り制限区域内に設置することが前提になっています。立ち入り制限区域とは、鍵、錠、またはその他の保全手段を使用しないと立ち入ることができない区域です。
주의	이 장치는 접근이 제한된 영역에 설치하도록 제작되었습니다. 특수 도구, 잠금 장치 및 키, 또는 기타 보안 수단을 통해서만 이 접근 제한 영역에 액세스할 수 있습니다.
Aviso	Esta unidade deve ser instalada em áreas de acesso restrito. Uma área de acesso restrito só pode ser acessada com o uso de uma ferramenta especial, cadeado e chave ou outros meios de segurança.
Advarsel	Denne enhed er beregnet til installation i områder med begrænset adgang. Der kan kun opnås adgang til et begrænset område ved at bruge et særligt stykke værktøj, lås og nøgle, eller en anden form for sikkerhed.
تحذير	تم تخصيص هذه الوحدة ليتم تثبيتها في مناطق محظور الوصول إليها. يمكن الوصول إلى المنطقة المحظورة فقط من خلال استخدام أداة خاصة أو قفل أو مفتاح أو أي وسيلة أخرى من التأمين.
Upozorenje	Uređaj je namijenjen ugradnji na teško dostupnim mjestima. Teško su dostupna mjesta takva mjesta koja su dostupna samo uz pomoć posebnih alata, lokota i ključa, ili nekog drugog načina osiguravanja sigurnosti.
Upozornění	Toto zařízení je určeno pro instalaci v prostorech s omezeným přístupem. Do prostoru s omezeným přístupem lze získat přístup pouze pomocí zvláštního nástroje, zámku a klíče nebo jiných zabezpečovacích prostředků.
Προειδοποίηση	Αυτή η συσκευή προορίζεται για να τοποθετηθεί σε χώρους στους οποίους η πρόσβαση είναι περιορισμένη. Η πρόσβαση σε ένα χώρο με περιορισμένη πρόσβαση είναι δυνατή μόνο με τη χρήση ενός ειδικού εργαλείου, κλειδαριάς και κλειδιού ή άλλου μέσου ασφαλείας.

אזהרה	יחידה זו מיועד להתקנה באזורים עם גישה מוגבלת. הגישה לאזורים המיועדים לגישה מוגבלת אפשרית רק באמצעות כלי מיוחד, מנעול ומפתח, או אמצעי בטיחות אחרים.
	Уредот е наменет за местeње во области со ограничен пристап. Во областите со ограничен пристап може да се влезе само со употреба на специјална алатка, брава и клуч или со други средства за обезбедување.
Ostrzeżenie	To urządzenie jest przystosowane do instalacji w miejscach o ograniczonym dostępie. Przez miejsce o ograniczonym dostępie rozumie się miejsce, do którego dostęp uzyskać można wyłącznie za pomocą specjalnego narzędzia, zamka z kluczem lub innego zabezpieczenia.
Upozornenie	Toto zariadenie je určené na inštaláciu v priestoroch s obmedzeným prístupom. Do priestoru s obmedzeným prístupom je možné získať prístup iba pomocou špeciálneho nástroja, zámku a kľúča, alebo iných zabezpečovacích prostriedkov.
Opozorilo	Ta enota je namenjena priključitvi na območjih z omejenim dostopom. Dostop do območja z omejenim dostopom je mogoč le z uporabo posebnega orodja, ključavnice, ključa ali kakšnega drugega varnostnega pripomočka.
警告	本裝置最好安裝於限制區域。限制區域只能透過特殊工具、鎖/鑰匙或其他保全工具出入。

Statement 1019—Main Disconnecting Device



Warning

The plug-socket combination must be accessible at all times, because it serves as the main disconnecting device.

Waarschuwing

De combinatie van de stekker en het elektrisch contactpunt moet te allen tijde toegankelijk zijn omdat deze het hoofdmechanisme vormt voor verbreking van de aansluiting.

Varoitus

Pistoke/liitinkohta toimii pääkatkaisumekanismina. Pääsy siihen on pidettävä aina esteettömänä.

Attention

La combinaison de prise de courant doit être accessible à tout moment parce qu'elle fait office de système principal de déconnexion.

Warnung

Der Netzkabelanschluß am Gerät muß jederzeit zugänglich sein, weil er als primäre Ausschaltvorrichtung dient.

Avvertenza

Il gruppo spina-presa deve essere sempre accessibile, poiché viene utilizzato come dispositivo di scollegamento principale.

Advarsel	Kombinasjonen støpsel/uttak må alltid være tilgjengelig ettersom den fungerer som hovedfrakoplingsenhet.
Aviso	A combinação ficha-tomada deverá ser sempre acessível, porque funciona como interruptor principal.
¡Advertencia!	El conjunto de clavija y toma ha de encontrarse siempre accesible ya que hace las veces de dispositivo de desconexión principal.
Varning!	Man måste alltid kunna komma åt stickproppen i uttaget, eftersom denna koppling utgör den huvudsakliga fråkopplingsanordningen.
Figyelem	A dugaszolóaljzat és a dugasz együttesének mindig hozzáférhetőnek kell lennie, mivel ez szolgál főmegszakítóként.
Предупреждение	Штепсельная розетка всегда должна быть доступна, поскольку она служит основным устройством отключения.
警告	插销和插座必须便于随时插拔，因为它是主要断电设备。
警告	主要な切断装置となるので、プラグとソケットは常に手が届く場所に置く必要があります。

Statement 1030—Equipment Installation



Warning

Only trained and qualified personnel should be allowed to install, replace, or service this equipment.

Waarschuwing

Deze apparatuur mag alleen worden geïnstalleerd, vervangen of hersteld door bevoegd geschoold personeel.

Varoitus

Tämän laitteen saa asentaa, vaihtaa tai huoltaa ainoastaan koulutettu ja laitteen tunteva henkilökunta.

Attention

Il est vivement recommandé de confier l'installation, le remplacement et la maintenance de ces équipements à des personnels qualifiés et expérimentés.

Warnung

Das Installieren, Ersetzen oder Bedienen dieser Ausrüstung sollte nur geschultem, qualifiziertem Personal gestattet werden.

Avvertenza

Questo apparato può essere installato, sostituito o mantenuto unicamente da un personale competente.

Advarsel	Bare opplært og kvalifisert personell skal foreta installasjoner, utskiftninger eller service på dette utstyret.
Aviso	Apenas pessoal treinado e qualificado deve ser autorizado a instalar, substituir ou fazer a revisão deste equipamento.
¡Advertencia!	Solamente el personal calificado debe instalar, reemplazar o utilizar este equipo.
Varning!	Endast utbildad och kvalificerad personal bör få tillåtelse att installera, byta ut eller reparera denna utrustning.
Figyelem	A berendezést csak szakképzett személyek helyezhetik üzembe, cserélhetik és tarthatják karban.
Предупреждение	Установку, замену и обслуживание этого оборудования может осуществлять только специально обученный квалифицированный персонал.
警告	只有经过培训且具有资格的人员才能进行此设备的安装、更换和维修。
警告	この装置の設置、交換、保守は、訓練を受けた相応の資格のある人が行ってください。
주의	교육을 받고 자격을 갖춘 사람만 이 장비를 설치, 교체, 또는 서비스를 수행해야 합니다.
Aviso	Somente uma equipe treinada e qualificada tem permissão para instalar, substituir ou dar manutenção a este equipamento.
Advarsel	Kun uddannede personer må installere, udskifte komponenter i eller servicere dette udstyr.
تحذير	يسمح للمنيين المتخصصين فقط بتركيب المعدة أو استبدالها أو إجراء الصيانة عليها.
Upozorenje	Uređaj smije ugrađivati, mijenjati i servisirati samo za to obučeno i osposobljeno servisno osoblje.
Upozornění	Instalaci, výměnu nebo opravu tohoto zařízení směji provádět pouze proškolené a kvalifikované osoby.
Προειδοποίηση	Η τοποθέτηση, η αντικατάσταση και η συντήρηση του εξοπλισμού επιτρέπεται να γίνονται μόνο από καταρτισμένο προσωπικό με τα κατάλληλα προσόντα.
הזהרה	Местењето, заменувањето и сервисирањето на оваа опрема треба да му биде дозволено само на обучен и квалификуван персонал.

Ostrzeżenie	Do instalacji, wymiany i serwisowania tych urządzeń mogą być dopuszczone wyłącznie osoby wykwalifikowane i przeszkolone.
Upozornenie	Inštaláciu, výmenu alebo opravu tohto zariadenia smú vykonávať iba vyškolené a kvalifikované osoby.
Opozorilo	Opremo lahko priključi, zamenja ali popravi le za to usposobljeno osebje.
警告	唯有經訓練的合格人員才能安裝、替換或維修該設備。

Statement 1040—Product Disposal



Warning

Ultimate disposal of this product should be handled according to all national laws and regulations.

Waarschuwing

Het uiteindelijke wegruimen van dit product dient te geschieden in overeenstemming met alle nationale wetten en reglementen.

Varoitus

Tämä tuote on hävitettävä kansallisten lakien ja määräysten mukaisesti.

Attention

La mise au rebut ou le recyclage de ce produit sont généralement soumis à des lois et/ou directives de respect de l'environnement. Renseignez-vous auprès de l'organisme compétent.

Warnung

Die Entsorgung dieses Produkts sollte gemäß allen Bestimmungen und Gesetzen des Landes erfolgen.

Avvertenza

Lo smaltimento di questo prodotto deve essere eseguito secondo le leggi e regolazioni locali.

Advarsel

Endelig kassering av dette produktet skal være i henhold til alle relevante nasjonale lover og bestemmelser.

Aviso

Deitar fora este produto em conformidade com todas as leis e regulamentos nacionais.

¡Advertencia!

Al deshacerse por completo de este producto debe seguir todas las leyes y reglamentos nacionales.

Varning!

Vid deponering hanteras produkten enligt gällande lagar och bestämmelser.

Figyelem

A készülék végső elhelyezéséről az adott országban érvényes törvények és előírások szerint kell intézkedni.

Предупреждение

警告	本产品的废弃处理应根据所有国家的法律和规章进行。
警告	この製品を廃棄処分する際は、各国の法律および規制に従って取り扱ってください。
주의	해당 국가의 관련 법규 및 규정에 따라 이 장치를 폐기해야 합니다.
Aviso	O descarte definitivo deste produto deve estar de acordo com todas as leis e regulamentações nacionais.
Advarsel	Endelig bortskaffelse af dette produkt skal ske i henhold til gældende love og regler.
تحذير	عند التخلص من المنتج يجب اتباع القوانين والتشريعات المحلية.
Upozorenje	Zbrinjavanje ovoga proizvoda u otpad treba provesti u skladu s važećim zakonima i odredbama.
Upozornění	Upozornění: Likvidace tohoto výrobku musí být provedena podle platných zákonů a předpisů.
Προειδοποίηση	Η τελική απόρριψη αυτού του προϊόντος πρέπει να γίνεται σύμφωνα με όλους τους εθνικούς νόμους και κανονισμούς.
אזהרה	סילוק סופי של מוצר זה חייב להיות בהתאם להנחיות ולחוקי המדינה.
	Крайното фрлање на овој производ треба да се изврши во согласност со сите национални закони и прописи.
Ostrzeżenie	Ostateczna likwidacja tego urządzenia po jego wycofaniu z eksploatacji powinna odbywać się zgodnie z przepisami krajowymi.
Upozornenie	Upozornenie Likvidácia tohto výrobku musí byť vykonaná podľa platných zákonov a predpisov.
Opozorilo	Uničenje izdelka, ki ni več uporaben, mora potekati po državnih zakonih in predpisih.
警告	本產品的最終處理必須遵照國家/地區的所有法律與法規。

Statement 1045—Short-circuit Protection



Warning

This product requires short-circuit (overcurrent) protection, to be provided as part of the building installation. Install only in accordance with national and local wiring regulations.

Waarschuwing

Voor dit product moet kortsluitbeveiliging (overstroombeveiliging) deel uitmaken van de installatie in het gebouw. De installatie moet voldoen aan de nationale en lokale bedradingvoorschriften.

Varoitus

Tämä tuote vaatii suojauksen oikosulkuja (ylivirtaa) vastaan osana asennusta rakennukseen. Asenna ainoastaan kansallisten ja paikallisten johdotussäännösten mukaisesti.

Attention

La protection de ce produit contre les courts-circuits (surtensions) doit être assurée par la configuration électrique du bâtiment. Vérifiez que l'installation a lieu uniquement en conformité avec les normes de câblage en vigueur au niveau national et local.

Warnung

Für dieses Produkt ist eine Kurzschlußsicherung (Überstromsicherung) erforderlich, die als Teil der Gebäudeinstallation zur Verfügung gestellt wird. Die Installation sollte nur in Übereinstimmung mit den nationalen und regionalen Vorschriften zur Verkabelung erfolgen.

Avvertenza

Questo prodotto richiede una protezione contro i cortocircuiti, da fornirsi come parte integrante delle dotazioni presenti nell'edificio. Effettuare l'installazione rispettando le Norme CEI pertinenti.

Advarsel

Dette produktet krever beskyttelse mot kortslutninger (overspenninger) som en del av installasjonen. Bare installer utstyret i henhold til nasjonale og lokale krav til ledningsnett.

Aviso

Este produto requer proteção contra curto-circuitos (sobrecorrente), que deve estar instalada nos edifícios. Instale apenas de acordo com as normas de instalação elétrica nacionais e locais.

Advertencia

Este producto necesita estar conectado a la protección frente a cortocircuitos (sobretensiones) que exista en el edificio. Instálelo únicamente en conformidad con las regulaciones sobre cableado, tanto locales como nacionales, a las que se tenga que atener.

Varning!

Denna produkt kräver att kortslutningsskydd (överström) tillhandahålles som en del av byggnadsinstallationen. Installera bara i enlighet med nationella och lokala kabeldragningsbestämmelser.

Figyelem

A termékhez kötelező rövidzárlat (túláram) elleni védelmet használni, amelyet az épület kábelezésének részeként kell biztosítani. Csak az országos és helyi kábelezési előírásoknak megfelelően helyezhető üzembe.

Предупреждение

Для этого устройства необходима защита от короткого замыкания (перегрузки), являющаяся частью электропроводки здания. При установке устройства необходимо соблюдать региональные и местные требования к электрооборудованию.

警告

此产品需要短路（过载电流）保护，这种保护要由建筑物内的供电电路提供。安装时必须遵守国家和当地有关布线的规章。

警告	この製品は、設置する建物にショート(過電流)保護機構が備わっていることを前提に設計されています。電気配線に関する一般規定および地域の規定に従って設置してください。
주의	이 제품은 단락(과전류) 보호가 필요하며, 이는 건물 설치의 일부로 제공됩니다. 국가 및 해당 지역 배선 규정에 따라 설치하십시오.
Aviso	Este produto requer uma proteção contra curto-circuito (sobrecorrente) que deve fazer parte da instalação do edifício. Faça a instalação somente de acordo com as regulamentações de cabeamento nacionais e locais.
Advarsel	Dette produkt kræver beskyttelse mod kortslutning (overstrøm). Dette skal være en del af installationen i bygningen. Installation skal ske i overensstemmelse med nationale og lokale ledningsregler.
تحذير	يجب وجود حماية من الدوائر الكهربائية القصير كجزء من تركيب الجهاز. قم بالتركيب طبقاً للتشريعات السلكية المحلية.
Upozorenje	Za ovaj je proizvod potrebna zaštita od prekomjerne količine struje (kratkoga spoja), koja mora biti ugrađena kao dio električnoga strujnog kruga. Zaštitu ugradite samo u skladu s važećim zakonima i propisima o ožičenju.
Upozornění	Upozornění: Tento výrobek vyžaduje ochranu proti zkratu (nadproudu), která je součástí instalace budovy. Instalaci provádějte pouze v souladu s platnými předpisy pro elektroinstalaci.
Προειδοποίηση	Αυτό το προϊόν απαιτεί στην κτιριακή εγκατάσταση να περιλαμβάνεται προστασία από βραχυκύκλωμα (υπέρ-ένταση). Η τοποθέτηση να γίνεται μόνο σύμφωνα με τους εθνικούς και τοπικούς κανονισμούς για την καλωδίωση.
אזהרה	למוצר זה נדרשת הגנה מפני קצר (זרם-יתר), המסופקת כחלק ממערך ההתקנה. יש להתקין רק בהתאם להנחיות החיווט הנהוגות המדינה וההנחיות המקומיות.
	За производот треба да се обезбеди заштита од краток spoj (преголем напон) што е вградена во инсталацијата на зградата. Местете ја инсталацијата само во согласност со националните и помесните прописи за електрично ожичување.
Ostrzeżenie	To urządzenie wymaga zastosowania zabezpieczenia przeciwzwarciowego (nadprądowego) jako elementu instalacji elektrycznej budynku. Należy je instalować zgodnie z krajowymi i lokalnymi przepisami dotyczącymi instalacji elektrycznych.
Upozornenie	Upozornenie Tento výrobok vyžaduje ochranu proti krátkemu spojeniu (nadprúdu), ktorá je súčasťou inštalácie budovy. Inštaláciu uskutočnite iba v súlade s platnými predpismi pre elektroinštaláciu.
警告	本產品必須有短路(過電流)保護,且該保護機制必須為建築安裝的一部份。安裝務必僅遵照國家/地區法規。

Statement 1046—Installing or Replacing the Unit

Warning

When installing or replacing the unit, the ground connection must always be made first and disconnected last.

Waarschuwing

Bij installatie of vervanging van het toestel moet de aardverbinding altijd het eerste worden gemaakt en het laatste worden losgemaakt.

Varoitus

Laitetta asennettaessa tai korvattaessa on maahan yhdistäminen aina tehtävä ensiksi ja maadoituksen irti kytkeminen viimeiseksi.

Attention

Lors de l'installation ou du remplacement de l'appareil, la mise à la terre doit toujours être connectée en premier et déconnectée en dernier.

Warnung

Der Erdanschluß muß bei der Installation oder beim Austauschen der Einheit immer zuerst hergestellt und zuletzt abgetrennt werden.

Avvertenza

In fase di installazione o sostituzione dell'unità, eseguire sempre per primo il collegamento a massa e disconnetterlo per ultimo.

Advarsel

Når enheten installeres eller byttes, må jordledningen alltid tilkobles først og frakobles sist.

Aviso

Ao instalar ou substituir a unidade, a ligação à terra deverá ser sempre a primeira a ser ligada, e a última a ser desligada.

¡Advertencia!

Al instalar o sustituir el equipo, conecte siempre la toma de tierra al principio y desconéctela al final.

Varning!

Vid installation eller utbyte av enheten måste jordledningen alltid anslutas först och kopplas bort sist.

Figyelem

A készülék üzembe helyezése és cserélése közben mindig a földelés vezetéket kell elsőként csatlakoztatni és azt kell utolsóként leválasztani.

Предупреждение

При установке или замене устройства контакт заземления должен подключаться первым, а отключаться последним.

警告

安装或更换该部件时，必须首先进行接地连接，而接地连接的断开应在最后进行。

警告

装置を設置または交換するときは、必ずアースを最初に接続し、最後に切断します。

주의

장치를 설치하거나 교체할 때, 항상 접지 연결을 먼저 해야하며 맨 나중에 연결을 해제해야 합니다.

Aviso

Ao instalar ou substituir a unidade, a conexão terra sempre deve ser executada primeiro e desconectada em seguida.

Advarsel	Ved installation og genmontering af enheden, skal jordforbindelsen altid installeres først og afinstalleres sidst.
تحذير	عند تركيب الوحدة أو استبدالها يجب إجراء اتصال أرضي ثم فصله بعد ذلك.
Upozorenje	Kod ugradnje uređaja najprije je potrebno priključiti uzemljenje, a kod zamjene to uzemljenje isključiti posljednje.
Upozornění	Při instalaci nebo výměně zařízení musí být uzemňovací připojení provedeno jako první a odpojeno jako poslední.
Προειδοποίηση	Όταν τοποθετείτε ή αντικαθιστάτε τη συσκευή, η σύνδεση γείωσης πρέπει να γίνεται πρώτη και να αποκαθίσταται τελευταία.
אזהרה	במהלך התקנה או החלפה של היחידה, חיבור ההארקה חייב להיות מחובר תמיד ראשון ומנותק אחרון.
	Когa го местите или заменувае уредот, приклучкот за вземјување секогаш треба да се направи прв и да се исклучи последна.
Ostrzeżenie	Podczas instalowania i wymiany urządzenia uziemienie należy zawsze podłączać w pierwszej kolejności, a odłączać jako ostatnie.
Upozornenie	Pri inštalácii alebo výmene zariadenia musí byť uzemňovacie pripojenie urobené ako prvé a odpojené ako posledné.
警告	安裝或置換裝置時，務必要先接地後再予以拆卸。

Statement 1051—Laser Radiation



Warning

Invisible laser radiation may be emitted from disconnected fibers or connectors. Do not stare into beams or view directly with optical instruments.

Waarschuwing

Losgekoppelde of losgeraakte glasvezels of aansluitingen kunnen onzichtbare laserstraling produceren. Kijk niet rechtstreeks in de straling en gebruik geen optische instrumenten rond deze glasvezels of aansluitingen.

Varoitus

Irrotetuista kuiduista tai liittimistä voi tulla näkymätöntä lasersäteilyä. Älä tuijota säteitä tai katso niitä suoraan optisilla välineillä.

Attention	Les fibres ou connecteurs débranchés risquent d'émettre des rayonnements laser invisibles à l'œil. Ne regardez jamais directement les faisceaux laser à l'œil nu, ni d'ailleurs avec des instruments optiques.
Warnung	Unterbrochene Fasern oder Steckverbindungen können unsichtbare Laserstrahlung abgeben. Blicken Sie weder mit bloßem Auge noch mit optischen Instrumenten direkt in Laserstrahlen.
Avvertenza	Le fibre ottiche ed i relativi connettori possono emettere radiazioni laser. I fasci di luce non devono mai essere osservati direttamente o attraverso strumenti ottici.
Advarsel	Det kan forekomme usynlig laserstråling fra fiber eller kontakter som er frakoblet. Stirr ikke direkte inn i strålene eller se på dem direkte gjennom et optisk instrument.
Aviso	Radiação laser invisível pode ser emitida de conectores ou fibras desconectadas. Não olhe diretamente para os feixes ou com instrumentos ópticos.
¡Advertencia!	Es posible que las fibras desconectadas emitan radiación láser invisible. No fije la vista en los rayos ni examine éstos con instrumentos ópticos.
Varning!	Osynlig laserstrålning kan avges från fränkopplade fibrer eller kontaktdon. Rikta inte blicken in i strålar och titta aldrig direkt på dem med hjälp av optiska instrument.
Figyelem	A nem csatlakoztatott üvegszálak és csatlakozók láthatatlan lézersugárzást bocsáthatnak ki. Ne nézzen bele a sugárba, és ne nézze közvetlenül, optikai berendezések segítségével!
Предупреждение	Отключенные световоды и разъемы могут испускать невидимое лазерное излучение. Не допускайте попадания лазерного луча в глаза и не смотрите на него через оптические приборы.
警告	断开的光纤或接头有可能发出不可见的激光辐射。请勿直视光束或直接用光学仪器观看光束。
警告	光ファイバ ケーブルまたはコネクタを取り外した状態では、目に見えないレーザー光が放射されていることがあります。光線をのぞきこんだり、光学機器を使用して光線を直接見たりしないでください。
주의	연결이 해제된 섬유나 커넥터에서 눈에 보이지 않는 레이저 방사열이 방출될 수 있습니다. 레이저 빔을 눈으로 쳐다 보거나 광학 기구를 사용하여 직접 보지 마십시오.
Aviso	Radiação laser invisível pode ser emitida a partir de fibras ou conectores desconectados. Não fixe o olhar nos feixes e nem olhe diretamente com instrumentos ópticos.
Advarsel	Usynlig laserstråling kan forekomme fra brukte fibre eller stik. Stir ikke ind i stråler eller direkte med optiske instrumenter.
تحذير	من المحتمل انبعاث أشعة الليزر من الألياف غير المتصلة أو التوصيلات. لا تحديق النظر في الشعاع أو النظر مباشرة بدون أي أداة بصرية.

Upozorenje	Postoji mogućnost laserskog zračenja iz iskopčanih vlakana ili priključaka. Nemojte gledati izravno u zrake niti ih promatrati optičkim instrumentima.
Upozornění	Odpojená vlákna kabelů či konektory mohou vyzařovat neviditelné laserové záření. Nedívejte se do paprsků ani nepozorujte přímo pomocí optických přístrojů.
Προειδοποίηση	Από αποσυνδεδεμένες ίνες ή υποδοχές μπορεί να εκπέμπεται αόρατη ακτινοβολία λέιζερ. Μην κοιτάτε απευθείας τις δέσμες φωτός και μην τις απεικονίζετε απευθείας με οπτικά όργανα.
אזהרה	תתיכן פליטה של קרינת לייזר בלתי-נראית מסיבים או ממחברים מנותקים. אל תביט ישירות לתוך קרני אור ואל תביט באמצעות במכשירים אופטיים. Невидливо ласерско зрачење може да зрачи од исклучените влакна или приклучоци. Не гледајте во зраци и не прегледувајте ги директно со оптички инструменти.
Ostrzeżenie	Odłączone światłowody lub złącza mogą emitować niewidzialne promieniowanie laserowe. Nie należy patrzeć prosto w wiązkę lasera ani bezpośrednio obserwować jej przy użyciu przyrządów optycznych.
Upozornenie	Odpojené vlákna káblov alebo konektory môžu vyžarovať neviditeľné laserové žiarenie. Nepozerajte sa do lúčov ani ich nepozorujte priamo pomocou optických prístrojov.
Opozorilo	Izključena vlakna ali konektorji lahko oddajajo nevidno lasersko sevanje. Ne glejte neposredno v laserske žarke oziroma pri tem ne uporabljajte optičnih naprav.

Statement 1072—Shock Hazard from Interconnections



Warning

Voltages that present a shock hazard may exist on Power over Ethernet (PoE) circuits if interconnections are made using uninsulated exposed metal contacts, conductors, or terminals. Avoid using such interconnection methods, unless the exposed metal parts are located within a restricted access location and users and service people who are authorized within the restricted access location are made aware of the hazard. A restricted access area can be accessed only through the use of a special tool, lock and key or other means of security.

Waarschuwing

Voltages kunnen elektrische schokken veroorzaken in PoE (Power over Ethernet)-circuits als er verbindingen worden gemaakt met blootliggende metalen contactpunten, geleiders of aansluitingspunten die niet zijn geïsoleerd. Gebruik dit type verbinding niet tenzij de blootliggende metalen onderdelen zich bevinden op een locatie met beperkte toegang en de gebruikers en onderhoudstechnici die toegang tot deze locatie hebben, op het gevaar worden gewezen. De locatie met beperkte toegang kan alleen worden geopend met speciaal gereedschap, slot en sleutel of een andere beveiligingsmethode.

Varoitus	Sisäisissä Ethernet (PoE) -virtapiireissä voi olla sähköiskun vaaran aiheuttavia jännitteitä, jos kytkentöihin käytetään eristämättömiä paljaita metalliliittimiä tai -johtimia. Vältä tällaisia kytkentöjä, elleivät paljaat metalliosat ole rajatussa paikassa. Ilmoita valtuutetuille käyttäjille ja huoltohenkilöille vaarasta. Rajattuun alueeseen pääsee käsiksi ainoastaan erityistyökäluu, lukkoa ja avainta tai muuta turvallista menetelmää käyttämällä.
Attention	Les tensions existant sur les alimentations utilisant la technologie PoE (Power over Ethernet) peuvent constituer un risque d'électrocution si les interconnexions sont effectuées en utilisant des terminaux, conducteurs ou contacts métalliques exposés non isolés. Évitez d'utiliser de telles méthodes d'interconnexion à moins que les pièces métalliques exposées ne se trouvent dans un emplacement d'accès restreint et que les utilisateurs et les responsables du service autorisés dans cet emplacement d'accès restreint ne soient conscients du danger. Une zone d'accès restreint peut être accédée uniquement à l'aide d'une clé, d'un outil et d'un verrou spécial, ou d'autres moyens de sécurité.
Warnung	Bei Power-over-Ethernet-(PoE-)Schaltkreisen besteht u.U. Stromschlaggefahr, wenn Verbindungen unter Verwendung nicht isolierter, freiliegender Metallkontakte, Leiter oder Anschlussklemmen hergestellt werden. Vermeiden Sie das Herstellen solcher Verbindungen, es sei denn, die freiliegenden Metallteile befinden sich an Orten mit beschränktem Zugang, und Personen, die Zugang dazu haben, sind ausdrücklich über diese Gefahr informiert worden. Ein Ort mit beschränktem Zugang ist nur mit Hilfe eines speziellen Werkzeugs, Schloss und Schlüssels oder anderen Sicherheitseinrichtungen zugänglich.
Avvertenza	Nei circuiti con alimentazione via Ethernet (PoE) possono verificarsi pericoli di scosse elettriche se si creano connessioni con contatti metallici, conduttori o terminali scoperti. Evitare di utilizzare i metodi di connessione sopraelencati a meno che le parti metalliche esposte non si trovino in una zona riservata e gli utenti e il personale di assistenza, che sono autorizzati ad accedere nella suddetta zona, siano stati messi al corrente del pericolo. È possibile accedere alla zona riservata solamente utilizzando gli appositi elementi di sicurezza.
Advarsel	I strømkretser med PoE (Power over Ethernet) kan det være spenninger som kan utgjøre støffare hvis det blir foretatt sammenkoblinger med uisolerte, eksponerte kontakter, ledere eller terminaler av metall. Unngå å bruke slike sammenkoblingsmetoder med mindre de eksponerte metalldelene er i et område med begrenset tilgang, og brukere og servicepersonell som har tilgang til det begrensede området, blir gjort oppmerksom på faren. Et område med begrenset tilgang kan bare åpnes ved hjelp av spesialverktøy, nøkkel eller andre sikkerhetstiltak.
Aviso	Pode haver voltagens que representam perigo de choque em circuitos PoE (Power over Ethernet) se as interconexões forem feitas utilizando-se terminais, condutores ou contatos de metal exposto e sem isolamento. Evite utilizar tais métodos de interconexão a não ser que as partes de metal expostas estejam em um local de acesso restrito e os usuários e o pessoal de serviço com acesso autorizado a este local restrito estejam cientes do perigo. Uma área de acesso restrito só pode ser acessada com o uso de uma ferramenta, fechadura e chave especial ou de outros meios de segurança.
¡Advertencia!	Puede haber voltajes con riesgo de shock en circuitos de alimentación sobre el cableado Ethernet (PoE), si para las interconexiones se utilizan contactos, conductores o terminales metálicos descubiertos. Evite tales métodos de interconexión, a menos que las partes metálicas descubiertas se encuentren en un lugar de acceso restringido y tanto los usuarios como el personal de servicios en dicho lugar sean conscientes de la existencia de tal riesgo. Sólo se puede tener acceso a una zona de acceso restringido mediante el uso de una herramienta especial, un candado y una llave u otros medios de seguridad.

Varning! Det kan finnas spänningar på PoE-kretsarna (Power over Ethernet) som utgör risk för stötar om sammankopplingarna görs med ej isolerade, exponerade kontakter, ledare och/eller terminaler av metall. Undvik att använda sådana sammankopplingsmetoder, såvida inte de exponerade metalldelarna finns i en plats med begränsad åtkomst. Användare och servicepersonal som tillåts inom platsen med begränsad åtkomst måste vara medvetna om risken. Ett begränsat område kan bara nås med ett speciellt verktyg eller lås, en speciell nyckel eller någon annan säkerhetsmetod.

Figyelem Áramütést okozó feszültség keletkezhet a feszültség alatt lévő Ethernet (Power over Ethernet, PoE) áramkörökben, amennyiben összeköttetés jön létre a szigetetlen fém érintkezők, vezetékek vagy csatlakozók között. Ne alkalmazzon ilyen összeköttetéseket, kivéve, ha az érintésnek kitett fém alkatrészek korlátozottan hozzáférhető területen találhatóak, és a terület elérésére felhatalmazott felhasználók és szervizszakemberek tudatában vannak az áramütés veszélyének. A korlátozottan hozzáférhető területekhez csak speciális szerszám, zár és kulcs, vagy más biztonsági berendezés segítségével lehet hozzáférni.

Предупреждение При выполнении соединений с использованием неизолированных металлических контактов, проводников или разъемов в электроцепях Power over Ethernet (PoE) могут возникать напряжения, представляющие опасность поражения электрическим током. Старайтесь не использовать такие способы соединений, если только неизолированные металлические части не находятся в местах, доступ к которым разрешен для ограниченного круга лиц, а пользователи и специалисты по обслуживанию, уполномоченные выполнять работы в таких местах, предупреждены о наличии такой опасности. При работе в местах, доступ к которым разрешен для ограниченного круга лиц, следует использовать только специальные инструменты, закрывать их на ключ или предпринимать другие меры безопасности.

警告 如果使用不绝缘、暴露的金属接头、导体或终端进行互联、在以太网供电 (PoE) 电路中就会产生导致电击危险的电压。只有暴露的金属部件处于限制进入的位置、并且被授权进入此位置的用户和服务人员意识到此危险、才能使用这样的互联方式。要进入受限区域、仅能使用特殊的工具、锁和密钥或其他安全方法。

警告 絶縁処理が施されていない金属製の部品、コンダクタ、またはターミナルを使用して内部接続されている場合、感電を引き起こす電圧が Power over Ethernet (PoE) 回路に存在する可能性があります。絶縁処理が施されていない金属製の部品がアクセス制限区域にのみ存在する場合や、アクセス制限区域への立ち入りが認められているユーザおよびサービス担当者が感電の可能性について熟知している場合を除き、そのような内部接続の方法は避けてください。アクセス制限区域には、特殊な工具、施錠などのセキュリティ手段を使用しなければアクセスできません。

Statement 1074—Comply with Local and National Electrical Codes



Warning

Installation of the equipment must comply with local and national electrical codes. Statement 1074

Waarschuwing

Bij installatie van de apparatuur moet worden voldaan aan de lokale en nationale elektriciteitsvoorschriften.

Varoitus	Laitteisto tulee asentaa paikallisten ja kansallisten sähkömääräysten mukaisesti.
Attention	L'équipement doit être installé conformément aux normes électriques nationales et locales.
Warnung	Die Installation der Geräte muss den Sicherheitsstandards entsprechen.
Avvertenza	L'installazione dell'impianto deve essere conforme ai codici elettrici locali e nazionali.
Advarsel	Installasjon av utstyret må samsvare med lokale og nasjonale elektrisitetsforskrifter.
Aviso	A instalação do equipamento tem de estar em conformidade com os códigos eléctricos locais e nacionais.
⚠️ Advertencia!	La instalación del equipo debe cumplir con las normativas de electricidad locales y nacionales.
Varning!	Installation av utrustningen måste ske i enlighet med gällande elinstallationsföreskrifter.
Figyelem	A berendezés üzembe helyezését a helyi és a nemzeti elektromossági előírások figyelembevételével kell elvégezni.
Предупреждение	Установка оборудования должна соответствовать местным и национальным электротехническим нормам.
警告	设备安装必须符合本地与本国电气法规。
警告	機器の取り付けは地域および国内の電気工事規定に遵守する必要があります。
주의	현지 및 국가 전기 규정에 따라 장비를 설치해야 합니다.
Aviso	A instalação do equipamento deve estar em conformidade com os códigos eléctricos nacionais.
Upozornění	Instalace zařízení musí splňovat příslušné místní a státní elektrotechnické normy.
Προειδοποίηση	Η εγκατάσταση του εξοπλισμού πρέπει να συμμορφώνεται με τους τοπικούς και εθνικούς κώδικες ηλεκτρολογικών εγκαταστάσεων.
אזהרה	התקנת הציוד חייבת להיות תואמת את חוקי החשמל המקומיים והארציים.
Ostrzeżenie	Instalacja sprzętu musi być zgodna z lokalnymi i krajowymi normami elektrycznymi.
Upozornenie	Inštalácia zariadenia sa musí vykonať v súlade s miestnymi a národnými predpismi pre inštaláciu elektrických zariadení.

Opozorilo Priključitev opreme mora potekati v skladu z lokalnimi in državnimi predpisi o električni opremi.

警告 設備安裝作業必須符合當地或國家電工法。

Statement 1075—Hazardous Voltage or Energy Present on DC Power Terminals



Warning

Hazardous voltage or energy may be present on DC power terminals. Always replace cover when terminals are not in service. Be sure uninsulated conductors are not accessible when cover is in place.

Waarschuwing

Op DC-aansluitingspunten kunnen zich gevaarlijke voltages of energieën voordoen. Plaats altijd de afsluiting wanneer de aansluitingspunten niet worden gebruikt. Zorg ervoor dat blootliggende contactpunten niet toegankelijk zijn wanneer de afsluiting is geplaatst.

Varoitus

Tasavirtaliittimissä saattaa olla huomattava jännite tai teho. Sulje suojus aina, kun liittimet eivät ole käytössä. Suojuksen ollessa suljettuna varmista, että kohde on suojattu eristämättömiltä johtimilta.

Attention

Le voltage ou l'énergie électrique des terminaux à courant continu peuvent être dangereux. Veillez à toujours remplacer le couvercle lors les terminaux ne sont pas en service. Assurez-vous que les conducteurs non isolés ne sont pas accessibles lorsque le couvercle est en place.

Warnung

In mit Gleichstrom betriebenen Terminals kann es zu gefährlicher Spannung kommen. Die Terminals müssen abgedeckt werden, wenn sie nicht in Betrieb sind. Stellen Sie bei Benutzung der Abdeckung sicher, dass alle nicht isolierten, stromführenden Kabel abgedeckt sind.

Avvertenza

I terminali di alimentazione DC potrebbero contenere voltaggio o energia pericolosi. Accertarsi di sostituire il coperchio ogni qualvolta i terminali non sono operativi. Accertarsi che i conduttori scoperti non siano accessibili quando il coperchio è inserito.

Advarsel

Det kan forekomme farlig spenning eller energi i likestrømsterminaler. Sett alltid dekselet på plass når terminalene ikke er i bruk. Kontroller at uisolerte ledere ikke er tilgjengelige når dekselet er på plass.

Aviso

Os terminais de corrente contínua podem fornecer tensão ou energia perigosa. Volte a colocar a tampa, sempre que os terminais não estiverem a ser utilizados. Certifique-se de que os condutores sem isolamento não estão acessíveis, quando a tampa estiver colocada.

¡Advertencia!

Puede haber energía o voltaje peligrosos en los terminales eléctricos de CC. Reemplace siempre la cubierta cuando no estén utilizándose los terminales. Asegúrese de que no haya acceso a conductores descubiertos cuando la cubierta esté colocada.

Varning!

Farlig spänning eller skadlig energi kan finnas i likströmsterminalerna. Sätt alltid tillbaka höljet när terminalerna inte används. Försäkra att inga oisolerade ledare kan nås när höljet sitter på plats.

Figyelem	Az egyenáramú csatlakozókon veszélyes feszültség vagy energia léphet fel. Ha a csatlakozók nincsenek bekötve, feltétlenül tegye vissza a fedelet. Ügyeljen rá, hogy a szigetetlen vezetőket ne lehessen megérinteni, ha a fedél fel van szerelve.
Предупреждение	На контактах питания постоянного тока может присутствовать опасное напряжение или энергия. Всегда устанавливайте крышку на место после завершения обслуживания. Когда крышка установлена, все неизолированные проводники должны быть недоступны.
警告	直流電源終端可能产生危险的电压或能量。终端不使用时，务必将机盖盖上。确认机盖盖上时，无法使用不绝缘导体。
警告	直流電力端子に危険な電圧やエネルギーが発生している可能性があります。使用していない端子には常にカバーを付けてください。カバーが付いているときは非絶縁形コンダクタに接触できないことを確認してください。
警告	DC 電源終端機上電壓高，十分危險。不使用終端機時請務必蓋上外罩。請檢查外罩蓋好後是否的確無法接觸未絕緣導線。

Regulatory Standards Compliance

This section includes all regulatory, safety, EMC (Class A or Class B), telecomm, and NEBS standards. The Catalyst 4948E and the Catalyst 4948E-F switches are in compliance with national and international standards as described in [Table D-1](#).

Table D-1 Standards Compliance

Specification	Standard
Regulatory Compliance	Products with the CE marking indicate compliance with the 2006/95/EC and 2004/108/EC directives, which include the safety and EMC standards listed.
Safety	UL 60950-1 Second Edition CAN/CSA-C22.2 No. 60950-1 Second Edition EN 60950-1 Second Edition IEC 60950-1 Second Edition AS/NZS 60950-1 GB4943 2001
EMC—Emissions	47CFR Part 15 (CFR 47) Class A AS/NZS CISPR22 Class A CISPR22 Class A EN55022 Class A

Table D-1 Standards Compliance (continued)

Specification	Standard
EMC—Emissions (continued)	ICES003 Class A VCCI Class A EN61000-3-2 EN61000-3-3 KN22 Class A CNS13438 Class A
EMC—Immunity	EN55024 CISPR24 EN300386 KN24

For specific details about the years, revisions, and relevant amendments, refer to the applicable declaration of conformity available at <http://www.cisco.com>.

The Catalyst 4948E and the Catalyst 4948E-F switches meets the industry EMC, safety, and environmental standards described in [Table D-2](#).

Table D-2 Industry EMC, Safety, and Environmental Standards

Specification	Standard
NEBS Criteria Levels	SR-3580 NEBS level 3 GR-63-CORE, issue 3; GR-1089 CORE, issue 5)
Verizon NEBS Compliance	Telecommunications Carrier Group (TCG) Checklist
Qwest NEBS requirements	Telecommunications Carrier Group (TCG) Checklist
ATT NEBS requirements	ATT TP76200 level 3 and TCG Checklist
ETSI	ETS 300 019-2-1, Class 1.2 Storage ETS 300 019-2-2, Class 2.3 Transportation ETS 300 019-2-3, Class 3.2 Stationary Use

GR-1089-CORE Issue 3 Documentation Statements

Statement 7016—GR-1089-Core Intrabuilding Lightning—Immunity Requirements



Caution

To comply with GR-1089-Core intrabuilding lightning-immunity requirements, you must use shielded (screened) cable that is grounded at both ends.

GR-1089-CORE Issue 4 Documentation Statements

Statement 7001—ESD Mitigation

This equipment may be ESD sensitive. Always use an ESD ankle or wrist strap before handling equipment. Connect the equipment end of the ESD strap to an unfinished surface of the equipment chassis or to the ESD jack on the equipment if provided.

Statement 7005—Intra-building Lightning Surge and AC Power Fault



Warning

The intra-building port(s) of the equipment or subassembly is suitable for connection to intra-building or unexposed wiring or cabling only. The intra-building port(s) of the equipment or subassembly **MUST NOT** metallicity connect to interfaces that connect to the OSP or its wiring. These interfaces are designed for use as intra-building interfaces only (Type 2 or Type 4 ports as described in GR-1089-CORE, Issue 4) and require isolation from the exposed OSP cabling. The addition of Primary Protectors is not sufficient protection in order to connect these interfaces metallicity to OSP wiring.

Statement 7012—Equipment Interfacing with AC Power Ports

This equipment shall be connected to AC mains provided with a surge protective device (SPD) at the service equipment complying with NFPA 70, the National Electrical Code (NEC).

Statement 7013—Equipment Bonding Networks

This equipment is suitable for installations utilizing the Common Bonding Network (CBN).

Statement 7014—Installation Location

This equipment is suitable for installation in Network Telecommunications Facilities and locations where the NEC applies.

Statement 7015—Equipment Bonding and Grounding

Paint and non-conductive coatings shall be removed before joining the surfaces between the equipment chassis and mounting metalwork. The surfaces shall be cleaned and an anti-oxidant compound applied before joining the surfaces.

Statement 7016—Battery Return Conductor

The battery return conductor of this equipment shall be treated as DC Isolated (DC-I).

Statement 7017—Minimum Steady State DC Input Voltage

This equipment will operate without degradation at a minimum steady state voltage of -40.5 VDC. The nominal DC input voltage rating is -48 VDC.

European Directives

Statement 2002—Declaration of Conformity with Regard to the Directives 2006/95/EC and 2004/108/EC

This equipment complies with the essential requirements and other provisions of Directives 2006/95/EC and 2004/108/EC. For more information, please refer to the Declaration of Conformity.

Statement 6005—California Perchlorate Contamination Prevention Act (Title 22, California Code of Regulations, Chapter 33)

The battery inside this product might contain perchlorate, a known hazardous substance, so special handling and disposal of this product might be necessary. For more information about perchlorate and best management practices for perchlorate-containing substances, see <http://www.dtsc.ca.gov/HazardousWaste/Perchlorate/index.cfm>.

EMC Class A Notices and Warnings

This section includes the EMC Class A warnings for the Catalyst 4948E and the Catalyst 4948E-F switches.

Statement 2017—Class A Notice for FCC

Modifying the equipment without Cisco's authorization may result in the equipment no longer complying with FCC requirements for Class A digital devices. In that event, your right to use the equipment may be limited by FCC regulations, and you may be required to correct any interference to radio or television communications at your own expense.

This equipment has been tested and found to comply with the limits for a Class A digital device, pursuant to Part 15 of the FCC Rules. These limits are designed to provide reasonable protection against harmful interference when the equipment is operated in a commercial environment. This equipment generates, uses, and can radiate radio frequency energy and, if not installed and used in accordance with the instruction manual, may cause harmful interference to radio communications. Operation of this equipment in a residential area is likely to cause harmful interference in which case users will be required to correct the interference at their own expense.

Statement 2021—Class A Notice for Canada

This Class A digital apparatus complies with Canadian ICES-003.

Cet appareil numérique de la classe A est conforme à la norme NMB-003 du Canada.

Statement 191—VCCI Class A Warning for Japan



Warning

This is a Class A product based on the standard of the VCCI Council. If this equipment is used in a domestic environment, radio interference may occur, in which case, the user may be required to take corrective actions.

警告

この装置は、クラスA情報技術装置です。この装置を家庭環境で使用すると電波妨害を引き起こすことがあります。この場合には使用者が適切な対策を講ずるよう要求されることがあります。

VCCI-A

Statement 256—Class A Warning for Hungary



Warning

This equipment is a class A product and should be used and installed properly according to the Hungarian EMC Class A requirements (MSZEN55022). Class A equipment is designed for typical commercial establishments for which special conditions of installation and protection distance are used.

Figyelem

Figyelmeztetés a felhasználói kézikönyv számára: Ez a berendezés "A" osztályú termék, felhasználására és üzembe helyezésére a magyar EMC "A" osztályú követelményeknek (MSZ EN 55022) megfelelően kerülhet sor, illetve ezen "A" osztályú berendezések csak megfelelő kereskedelmi forrásból származhatnak, amelyek biztosítják a megfelelő speciális üzembe helyezési körülményeket és biztonságos üzemelési távolságok alkalmazását.

Statement 257—Class A Notice for Taiwan and Other Traditional Chinese Markets



Warning

This is a Class A Information Product, when used in residential environment, it may cause radio frequency interference, under such circumstances, the user may be requested to take appropriate countermeasures. Statement 257

警告

這是甲類資訊產品，在居住環境中使用時，可能會造成射頻干擾，在這種情況下，使用者會被要求採取某些適當的對策。

Statement 294—Class A Warning for Korea



Warning

This is a Class A Device and is registered for EMC requirements for industrial use. The seller or buyer should be aware of this. If this type was sold or purchased by mistake, it should be replaced with a residential-use type.

주의

A급 기기 이 기기는 업무용으로 전자파 적합 등록을 한 기기이오니 판매자 또는 사용자는 이 점을 주의하시기 바라며 만약 잘못 판매 또는 구입하였을 때에는 가정용으로 교환하시기 바랍니다.

Statement 340—Class A Warning for CISPR22



Warning

This is a class A product. In a domestic environment this product may cause radio interference in which case the user may be required to take adequate measures. Statement 340

Waarschuwing

Dit is een product van klasse A. In een woonomgeving kan dit product radiostoring veroorzaken. In dat geval moet de gebruiker de juiste maatregelen nemen.

Varoitus

Tämä on A-luokan tuote. Kotona käytettynä tämä tuote voi aiheuttaa radiotaajuushäiriötä, jolloin käyttäjän tulisi ryhtyä vaadittaviin toimenpiteisiin häiriöiden ehkäisemiseksi.

Attention

Il s'agit d'un produit de classe A. Dans un environnement local, ce produit peut entraîner des perturbations radioélectriques, auquel cas l'utilisateur devra éventuellement prendre des mesures adéquates.

Warnung

Dies ist ein Produkt der Klasse A. Bei der Verwendung dieses Produkts im Haus- oder Wohnungsbereich kann es zu Funkstörungen kommen. In diesem Fall muss der Benutzer u. U. angemessene Maßnahmen ergreifen.

Avvertenza

Prodotto di classe A. È possibile che il prodotto generi interferenze radio in un ambienti chiusi. In questo caso l'utente deve intraprendere le misure adeguate per risolvere il problema.

Advarsel

Dette er et produkt i klasse A. I et hjemmemiljø kan dette produktet forårsake radioforstyrrelser, og brukeren kan da være nødt til å ta de nødvendige forholdsregler.

Aviso

Este é um produto de classe A. Em um ambiente doméstico, este produto pode causar interferência de rádio. Nesse caso, talvez o usuário precise tomar as medidas adequadas.

¡Advertencia!

Este es un producto de clase A. En el ámbito doméstico, este producto puede causar radiointerferencias, lo que puede hacer necesaria la puesta en marcha de medidas adecuadas.

Varning!

Detta är en klass A-produkt. Denna produkt kan orsaka radiostörningar inomhus. Det kan då vara ett krav att användaren vidtar lämpliga åtgärder.

Figyelem

Ez egy A osztályba tartozó termék. Lakáson belüli környezetben előfordulhat, hogy a termék rádióvédelmi interferenciát okoz; ilyen esetben megfelelő lépéseket kell tenni a zavar megszüntetése érdekében.

Предупреждение

Данное изделие относится к классу А. При установке в жилых помещениях данное изделие может стать причиной радиопомех, в результате чего пользователю может потребоваться предпринять соответствующие меры.

警告

这是类别 A 产品。在家用环境中，该产品可能会引起无线电干扰，此时用户需要采取适当措施。

警告

この装置はクラスA製品です。この装置を住宅地で使用した場合、電波妨害を引き起こすことがあります。その場合、ユーザが適切な防止措置を講じるよう求められることがあります。

Upozornění	Toto je produkt třídy A. V domácím prostředí může způsobovat rušení radiových vln. V takovém případě musí uživatel provést příslušná opatření.
Προειδοποίηση	Αυτό είναι ένα προϊόν κλάσης A. Σε οικιακό περιβάλλον, αυτό το προϊόν ενδέχεται να προκαλέσει παρεμβολές ("παράσιτα") και σε μια τέτοια περίπτωση ο χρήστης ενδέχεται να χρειαστεί να λάβει τα κατάλληλα μέτρα.
Ostrzeżenie	Jest to produkt klasy A. W środowisku domowym produkt ten może powodować zakłócenia radiowe, wymagające od użytkownika podjęcia odpowiednich czynności zaradczych.
Upozornenie	Toto je výrobok triedy A. Tento výrobok môže v domácom prostredí spôsobovať rádiové rušenie a v takom prípade sa môže vyžadovať, aby jeho používateľ vykonal adekvátne opatrenia.
Upozornění	Toto je produkt třídy A. V domácím prostředí může způsobovat rušení radiových vln. V takovém případě musí uživatel provést příslušná opatření.

Statement 371—Power Cable and AC Adapter

接続ケーブル、電源コード、ACアダプタ、バッテリーなどの部品は、必ず添付品または指定品をご使用ください。添付品・指定品以外の部品をご使用になると故障や動作不良、火災の原因となります。また、電気用品安全法により、当該法の認定（PSEとコードに表記）でなくUL認定（ULまたはCSAマークがコードに表記）の電源ケーブルは弊社が指定する製品以外の電気機器には使用できないためご注意ください。



INDEX

Numerics

19- and 24-inch racks [3-5](#)

A

accessory kit, contents of [3-4](#)

AC-input power supplies [A-1 to A-11](#)

300 W power supply features [A-2, A-5](#)

AC power cords listing [A-8](#)

branch circuit requirements [2-12, A-3, A-6](#)

fan [A-3, A-6](#)

front panel LEDs [A-7](#)

input current [A-3, A-6](#)

input voltage [A-3, A-6](#)

LEDs [A-4](#)

PWR-C49E-300AC-F [A-5](#)

PWR-C49E-300AC-F specifications table [A-6](#)

PWR-C49E-300AC-R [A-1](#)

PWR-C49E-300AC-R specifications table [A-3](#)

removal and replacement procedures [4-8](#)

source AC circuit requirements [2-12](#)

weight [A-4, A-7](#)

AC power cords [A-8](#)

AC source power, connecting to the chassis [3-12](#)

adapter, RJ-45 to DB-9 [B-13](#)

airflow

Catalyst 4948E and Catalyst 4948E-F switches [1-7](#)

air flow, chassis [2-4](#)

air temperature, ambient [2-4](#)

altitude, effects on chassis [2-5](#)

altitude, operating [1-7](#)

audience, definition [i-ix](#)

B

brackets

cable guide installation [3-9](#)

rack-mounting L brackets [3-6](#)

branch circuit requirements, AC-input power supplies [2-12](#)

C

cable guide [3-9](#)

installing [3-8](#)

cables and adapters [B-12](#)

cable static buildup caution [2-9](#)

cabling

requirements and guidelines [2-13](#)

Catalyst 4948E and Catalyst 4948E-F switches

acoustic noise [1-7](#)

airflow [1-7](#)

chassis dimensions [1-7](#)

environmental specifications [1-7](#)

features table [1-3](#)

front view of chassis [1-2](#)

physical characteristics [1-7](#)

rear view of chassis [1-3](#)

specifications [1-7](#)

Catalyst 4948E-F airflow labels [1-2](#)

Catalyst 4948E-F switches

blank power supply cover [1-6](#)

console port [1-4](#)

downlink port LEDs [1-4](#)

downlink ports [1-4](#)

Ethernet management port [1-4](#)

- fan tray [1-5](#)
- fan tray LED [1-5](#)
- power supplies
 - description [1-6](#)
- RESET switch [1-5](#)
- uplink port LEDs [1-4](#)
- uplink ports [1-4](#)
- Catalyst 4948E switches
 - blank power supply cover [1-6](#)
 - console port [1-4](#)
 - downlink port LEDs [1-4](#)
 - downlink ports [1-4](#)
 - Ethernet management port [1-4](#)
 - fan tray [1-5](#)
 - fan tray LED [1-5](#)
 - power supplies
 - description [1-6](#)
 - RESET switch [1-5](#)
 - shock and vibration specifications [1-7](#)
 - uplink port LEDs [1-4](#)
 - uplink ports [1-4](#)
- caution definition [i-xi](#)
- chassis, front view [1-2](#)
- chassis, rear view [1-3](#)
- chassis features [1-3](#)
- chassis features (front view) [1-2](#)
- chassis installation, tools required [3-4](#)
- checklist, site preparation [2-13](#)
- command conventions [i-x](#)
- configuration
 - initial switch configuration [3-21](#)
 - terminal-emulation software [3-21](#)
- console port
 - connecting to [3-20](#)
 - description [1-4](#), [B-11](#)
 - LED [B-12](#)
 - pinout table [B-11](#)
- conventions, command [i-x](#)
- corrosion, sources of [2-6](#)

- customer service [C-4](#)
- CWDM SFP transceivers [B-5 to B-6](#)
 - description and color code [B-6](#)
 - optical specifications [B-6](#)

D

- DC-input power supplies [A-12 to A-13](#)
 - fan [A-13](#)
 - features [A-12](#)
 - heat dissipation [A-12](#)
 - input current [A-12](#)
 - input voltages [A-12](#)
 - LEDs [A-13](#)
 - output voltage and current [A-12](#)
 - removal and replacement procedures [4-2](#)
 - removal procedure [4-2](#)
 - required tools [4-2](#)
 - specifications table [A-12](#)
 - weight [A-13](#)
- DC power, connecting to the chassis [3-14](#)
- DC power cables, requirements for [2-12](#)
- DC power supplies
 - circuit breaker requirements [2-12](#)
- dimensions, chassis [1-7](#)
- documentation
 - audience [i-ix](#)
 - obtaining [i-xvi](#)
 - organization [i-ix](#)
 - related [i-x](#)
- downlink ports
 - connecting interface cables to [3-16](#)
 - description [1-4](#)
 - LEDs [1-4](#)
- dust and particulates, effects on chassis [2-5](#)
- DWDM SFP transceivers [B-7 to B-8](#)
 - optical specifications [B-8](#)
 - physical and environmental specifications [B-8](#)
 - product numbers and ITU channel numbers [B-7](#)

E

- electrical safety [2-9](#)
- Electromagnetic Interference. See EMI
- Electrostatic Discharge. See ESD
- EMI, effects on chassis [2-6](#)
- environmental specifications [1-7](#)
- equipment racks [2-2](#)
- ESD
 - attaching a wrist strap to the chassis [2-11](#)
 - guidelines [2-10](#)
 - preventing [2-10](#)
 - using a ground strap [2-10](#)
- Ethernet management port
 - connecting to [3-20](#)
 - description [1-4, 3-20, B-12](#)
 - LED [B-12](#)
 - pinout table [B-12](#)

F

- FAN LED [1-11](#)
- fan tray
 - color code [1-5](#)
 - installing [4-11](#)
 - LEDs [1-5](#)
 - removal and replacement procedure [4-10](#)
 - required tools [4-10](#)
- fan tray (WS-X4993)
 - description [1-5](#)
- fan tray (WS-X4993-F)
 - description [1-5](#)
- features, chassis [1-3](#)
- front panel LEDs [1-11](#)

G

- grounding. See system ground

H

- heat dissipation, chassis [1-7](#)
- humidity [1-7](#)
 - operating [1-7](#)
- humidity, effects on chassis [2-5](#)

I

- installation
 - lifting safely [3-5](#)
 - list of warnings [3-2](#)
 - rack-mounting [3-5 to 3-8](#)
 - required tools [3-4](#)
 - starting the terminal-emulation software [3-21](#)

L

- label, chassis serial number [C-4](#)
- L brackets, attaching to the chassis [3-6](#)
- LEDs
 - AC-input power supplies [A-4, A-7](#)
 - DC-input power supplies [A-13](#)
 - downlink ports [1-4](#)
 - fan tray [1-5](#)
 - front panel [1-11](#)
 - power-on self-test (POST) failures [3-22](#)
 - power supply [C-3](#)
 - uplink ports [1-4](#)
- LINK LED [1-11](#)

M

- management port pinout [B-12](#)

N

- NEBS ground

See system ground

note definition [i-xi](#)

O

operating temperature, chassis [1-7](#)

organization, document (table) [i-ix](#)

P

physical and environmental specifications tables

transceivers

1-GB SFP transceivers [B-6](#)

physical characteristics

Catalyst 4948E and Catalyst 4948E-F [1-7](#)

pinout

management port [B-12](#)

POST

LEDs [3-22](#)

power

connecting source DC [3-14](#)

troubleshooting [C-2](#)

power cords [A-8](#)

power requirements

AC-input power supplies branch circuit requirements [2-12](#)

site preparation [2-11](#)

UPS, selecting a UPS [2-11](#)

power source interruptions, effects on chassis [2-7](#)

power supplies

AC-input power supplies installation procedure [4-9](#)

AC-input power supplies removal procedure [4-8](#)

DC-input power supplies removal and replacement procedure [4-2](#)

DC power cable leads color coding [2-12](#)

LEDs [C-3](#)

troubleshooting [C-3, C-4](#)

power supply

troubleshooting [C-4](#)

power supply, blank cover (Catalyst 4948E) [1-6](#)

power supply, blank cover (Catalyst 4948E-F) [1-6](#)

power supply fan speeds (table) [A-5, A-8, A-14](#)

PS1 LED [1-11](#)

PS2 LED [1-11](#)

R

rack-mounting [3-5 to 3-8](#)

kit [3-4](#)

required tools [3-4](#)

rack-mounting guidelines [2-2](#)

related documentation [i-x](#)

removal and replacement procedures

AC-input power supplies [4-8](#)

DC-input power supplies [4-2](#)

fan tray [4-10](#)

RESET switch

accessing [1-5](#)

description [1-5](#)

function [1-5](#)

rollover cables

description [B-12](#)

identifying colors [B-13](#)

S

safety

translated safety warnings [D-2](#)

safety, lifting the chassis [3-5](#)

safety with electricity [2-9](#)

serial number, chassis [C-4](#)

service requests [i-xvi](#)

SFP+ transceivers [B-9 to B-11](#)

cabling specifications [B-10](#)

copper features [B-9](#)

optical features [B-9](#)

physical and environmental specifications [B-11](#)

- transmit and receive specifications [B-11](#)
- SFP transceivers [B-1 to B-5](#)
 - 1-GB SFP transceivers
 - physical and environmental specifications table [B-6](#)
 - copper transceiver features [B-2](#)
 - fiber loss budgets table [B-5](#)
 - optical transceiver features [B-2](#)
 - physical and environmental specifications table [B-5](#)
 - specifications table [B-4](#)
 - transceivers supported [B-1](#)
- shock and vibration, effects on chassis [2-7](#)
- shock and vibration specifications [1-7](#)
- site preparation checklist [2-13](#)
- site requirements [2-2](#)
 - air flow [2-4](#)
 - altitude [2-5](#)
 - corrosion [2-6](#)
 - dust and contamination [2-5](#)
 - EMI [2-6](#)
 - humidity [2-5](#)
 - power interruptions [2-7](#)
 - shock and vibration [2-7](#)
 - temperature [2-3](#)
- software documentation [i-x](#)
- specifications, chassis [1-7](#)
- startup sequence [C-3](#)
- STATUS LED [1-11](#)
- storage [1-7](#)
- storage temperature, chassis [1-7](#)
- syntax, command [i-x](#)
- system ground
 - accessory kit [3-10](#)
 - grounding lug [3-10](#)
 - ground pad location [3-11](#)
 - guidelines [2-8](#)
 - installing [3-10](#)
 - kit [3-4](#)
 - requirement [3-10](#)

- requirements [2-7, 2-9](#)
- tools required [3-10](#)
- system ground kit [3-4](#)

T

- telco racks [3-5](#)
- temperature
 - chassis operating [1-7](#)
- temperature, site requirements [2-3](#)
- temperature, storage [1-7](#)
- temperature, thermal transition [1-7](#)
- terminal-emulation software [3-21](#)
- thermal transition temperature [1-7](#)
- tip definition [i-xi](#)
- troubleshooting
 - contacting customer service [C-4](#)
 - initial boot [C-2](#)
 - methodology [C-2](#)
 - power supplies [C-4](#)
 - power supply [C-3, C-4](#)
 - startup [C-3](#)

U

- uplink ports
 - connecting to [3-16](#)
 - description [1-4](#)
 - LEDs [1-4](#)
 - transceivers [3-16](#)
- UPS, selecting [2-11](#)

W

- warning definition [i-xi](#)
- warnings
 - translated safety [D-2](#)
- warnings, installation [3-2](#)

weight, chassis [1-7](#)

wrist strap, ESD [2-10](#)