



myxfitness.
Product Manual



Contents

SAFETY INFORMATION	3	TABLET SETUP	
Notices	4	Powering On the Tablet	16
		Connecting to Internet	16
PRODUCT OVERVIEW	5		
		CARING FOR YOUR MYX	
PRODUCT FEATURES		Maintenance	17
MYX Bike Features	6	Cleaning	17
MYX Tablet Features	7	Warnings and Cautions	18
HARDWARE SETUP		LIMITED PRODUCT WARRANTY	19
Moving the Bike	8		
Tablet and Mounting Arm	9	APPENDIX	
Connect Power Cord	10	Contact	23
Adjusting Seat and Handlebar Height	10		
Adjusting Seat and Handlebar Depth	11		
Mounting and Dismounting	12		
Adjusting Resistance	12		
Using Pedal Clips and Cage	13		
SPEED SENSOR	14		
HEART RATE MONITOR SETUP			
Charge Battery	15		
Using Your Heart Rate Monitor	15		

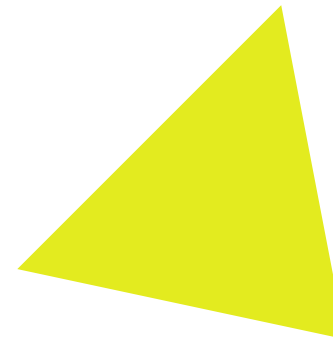

Safety Information

▲WARNING CAREFULLY READ AND FOLLOW ALL SAFETY AND OTHER INSTRUCTIONS IN THIS MANUAL BEFORE USING THE PRODUCT. FAILURE TO DO SO MAY RESULT IN DEATH OR SERIOUS INJURY TO YOU AND/OR OTHERS:

- Consult your physician and receive approval to proceed before beginning any exercise. Stop exercising if you feel pain or tightness in your chest, become short of breath, or feel faint, and consult your physician immediately.
- **Weight Limitation.** The product is not intended to be used by persons over 350 lbs (159 kgs).
- **Height Restrictions.** Users must be at least between 4'11" and 6'8" tall.
- **Age Restrictions.** Children under the age of 13 must not use the product. For persons between 13 and 18 years of age, you must consult and receive approval from both your physician and parent/guardian before beginning.
- **Emergency Stopping:** To stop the bike and flywheel immediately, push down and hold the resistance knob. This acts as an emergency brake.
- Keep children, pets and any other obstacles away from the product at all times.
- Keep hands, loose clothing, shoelaces, and accessories away from moving parts. Do not insert objects into any crevices or openings on the product.
- Position the product with a minimum of 24 inches (approx. 0.61 meters) of clearance on all sides for safety and to allow for ease of mounting and dismounting.
- Use caution when mounting and dismounting. Do not dismount until the pedals come to a complete stop. Mounting or dismounting while pedals are moving can seriously injure the user.
- This product is not intended to be used by persons with reduced physical, sensory, or mental capabilities or lack of experience and knowledge.
- If you have a pacemaker or other implanted electronic device, consult your physician before using a wireless chest strap or other telemetric heart rate monitor.
- This product must be set up and operated on a solid level surface.
- Do not use the product until it has been fully assembled and inspected for correct performance in accordance with this manual. Do not alter the design or functionality of the product, as it could compromise user safety.
- Inspect the product thoroughly prior to each use (such as for wear or damage) to ensure it is functioning correctly and perform regular maintenance for optimal performance and longevity. Replace damaged or worn parts immediately and do not use the product until repairs are performed.
- Always adjust the seat and handlebars to your personal requirements before each use to avoid injury.
- The product is intended to be used with SPD-compatible clips. Do not use any other type of clips. You must wear shoes during use; never use the product with bare feet or while only wearing socks
- The product is for indoor use only. Do not store the product outdoors, near water or at high humidity levels. Do not operate the product in damp or wet locations.
- The product is for home use only. Do not use in a commercial setting.
- Use the product only for its intended purpose. Perform MYX bike exercises and use MYX bike content only with the MYX bike.
- To reduce the risk of electrical shock, always unplug the product before attempting any preventative maintenance or cleaning activity.
- Metrics and values presented on screen, such as heart rate, cadence and resistance may be inaccurate. Please use them for reference only.
- Keep this manual for future reference.

Notices

- Changes or modifications to this product not expressly approved by the party responsible for compliance could void the user's authority to operate the equipment.
- This device complies with part 15 of the FCC Rules. Operation is subject to the following two conditions: (1) This device may not cause harmful interference, and (2) this device must accept any interference received, including interference that may cause undesired operation.

Note: This equipment has been tested and found to comply with the limits for a Class B digital device, pursuant to part 15 of the FCC Rules. These limits are designed to provide reasonable protection against harmful interference in a residential installation. This equipment generates, uses and can radiate radio frequency energy and, if not installed and used in accordance with the instructions, may cause harmful interference to radio communications. However, there is no guarantee that interference will not occur in a particular installation. If this equipment does cause harmful interference to radio or television reception, which can be determined by turning the equipment off and on, the user is encouraged to try to correct the interference by one or more of the following measures:

1. Reorient or relocate the receiving antenna.
2. Increase the separation between the equipment and receiver.
3. Connect the equipment into an outlet on a circuit different from that to which the receiver is connected.
4. Consult the dealer or an experienced radio/TV technician for help.

Product Overview

SPECIFICATIONS

Weight	150 lbs (68 kg)
Width	21" (53 cm)
Length	55" (140 cm)
Height	47" (119 cm)
Max User Weight	350 lbs (159 kg)
Required User Height	4'11" - 6'8"



MYX Bike Features



MYX Tablet Features

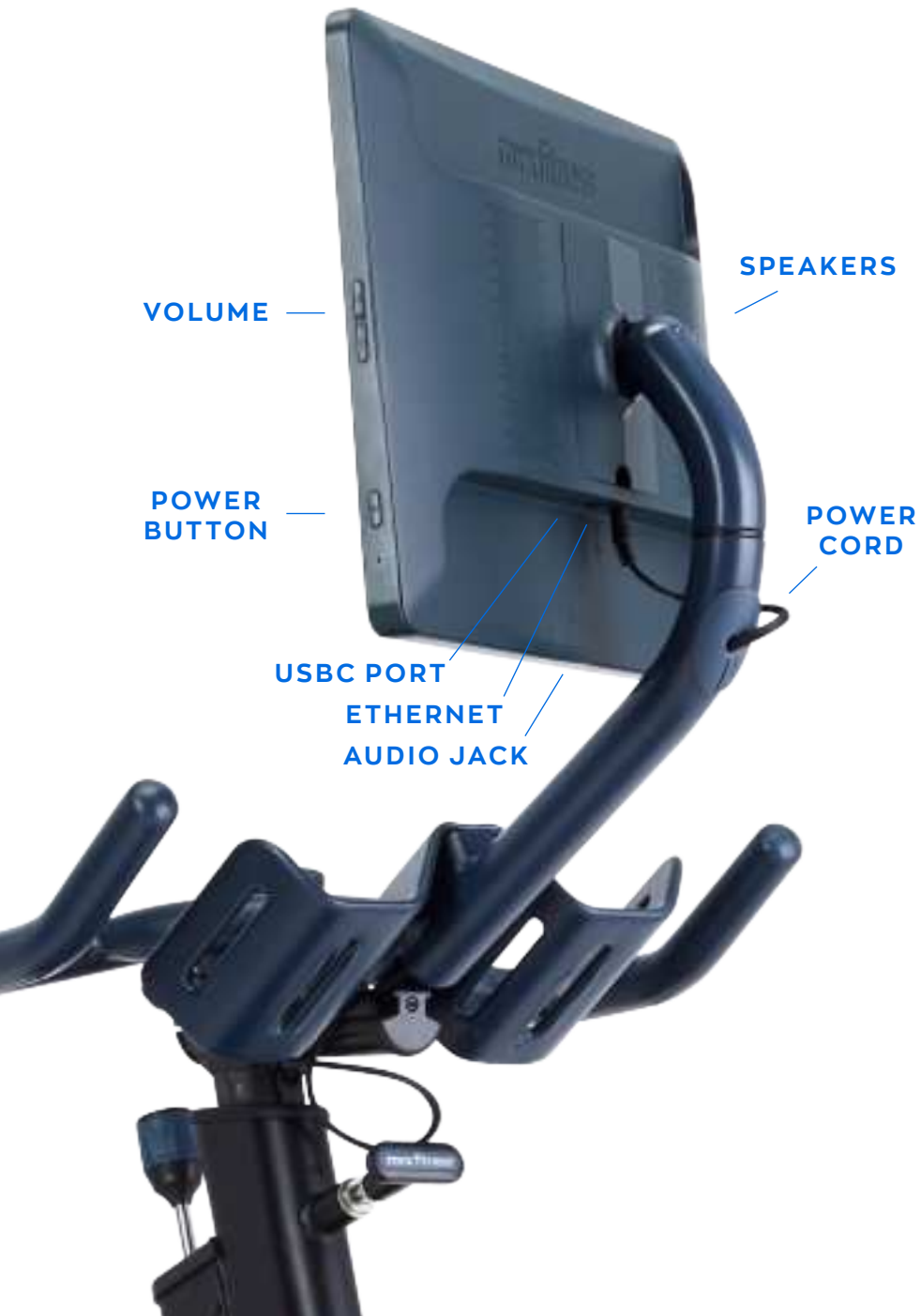

Hardware Setup

MOVING THE BIKE

⚠ WARNING This product must be set up and operated on a solid level surface. If your bike is not level, adjust the four leveling feet located on the underside of the front and rear legs (see figure 4) until all four feet are evenly contacting the floor.

⚠ CAUTION Use two people to move the product, since it weighs over 150 lbs (68 kgs).

1. Have one person lift the rear stabilizer to tilt the bike forward onto the transport wheels, while the other person holds the handlebars.
2. Roll the bike forward to the new location.
3. Lower the rear stabilizer to the floor.
4. Unscrew leveling feet if needed to prevent rocking on uneven floors.

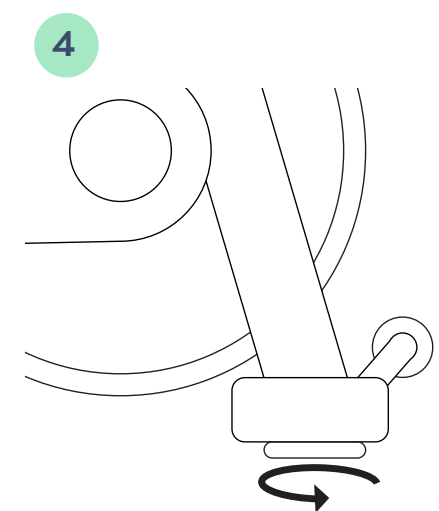
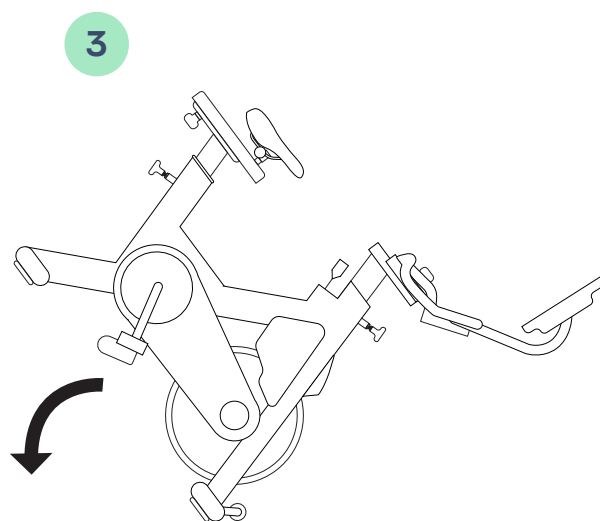
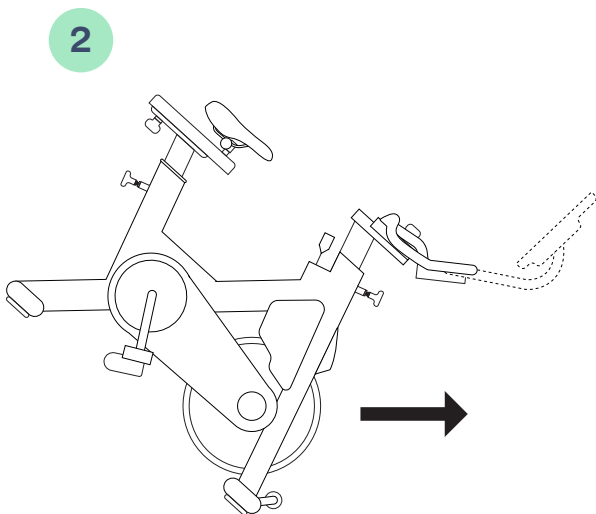
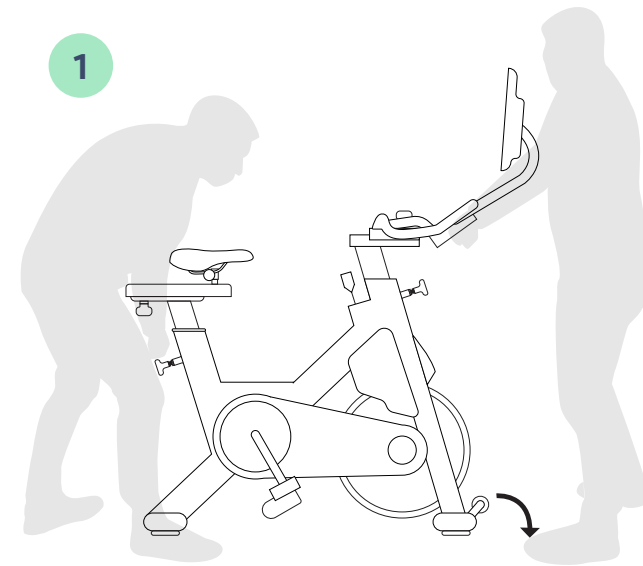

TABLET AND MOUNTING ARM

Your tablet will be assembled by the setup team, but it can be easily removed and reattached for ease of transportation later.

⚠ CAUTION Use two people to remove or reattach the tablet and mounting arm.

Disassembly

1. Remove the plastic covers to reveal the mounting screws. Have one person support the tablet while the other person uses the 4mm Phillips screwdriver from the toolkit to remove the four 4mm screws at the back of the tablet.
2. Lift off the tablet and set the screws aside.
3. Have one person support the mounting arm, while the other loosens and removes the two 9mm screws.
4. Remove the mounting arm and the oval mounting plate.

Assembly

1. Align oval mounting plate with the two holes at the center of the bottle holder bracket.
2. Align mounting arm below the bottle holder bracket.
3. Insert and tighten two 9mm mounting screws through the oval plate, bracket holes, and into the holes on the mounting arm.
4. Align the tablet with the 4-hole plate at the top of the mounting arm.
5. Insert four 4mm screws through the plate and into the mounting holes in the back of tablet and tighten. Replace the plastic covers.

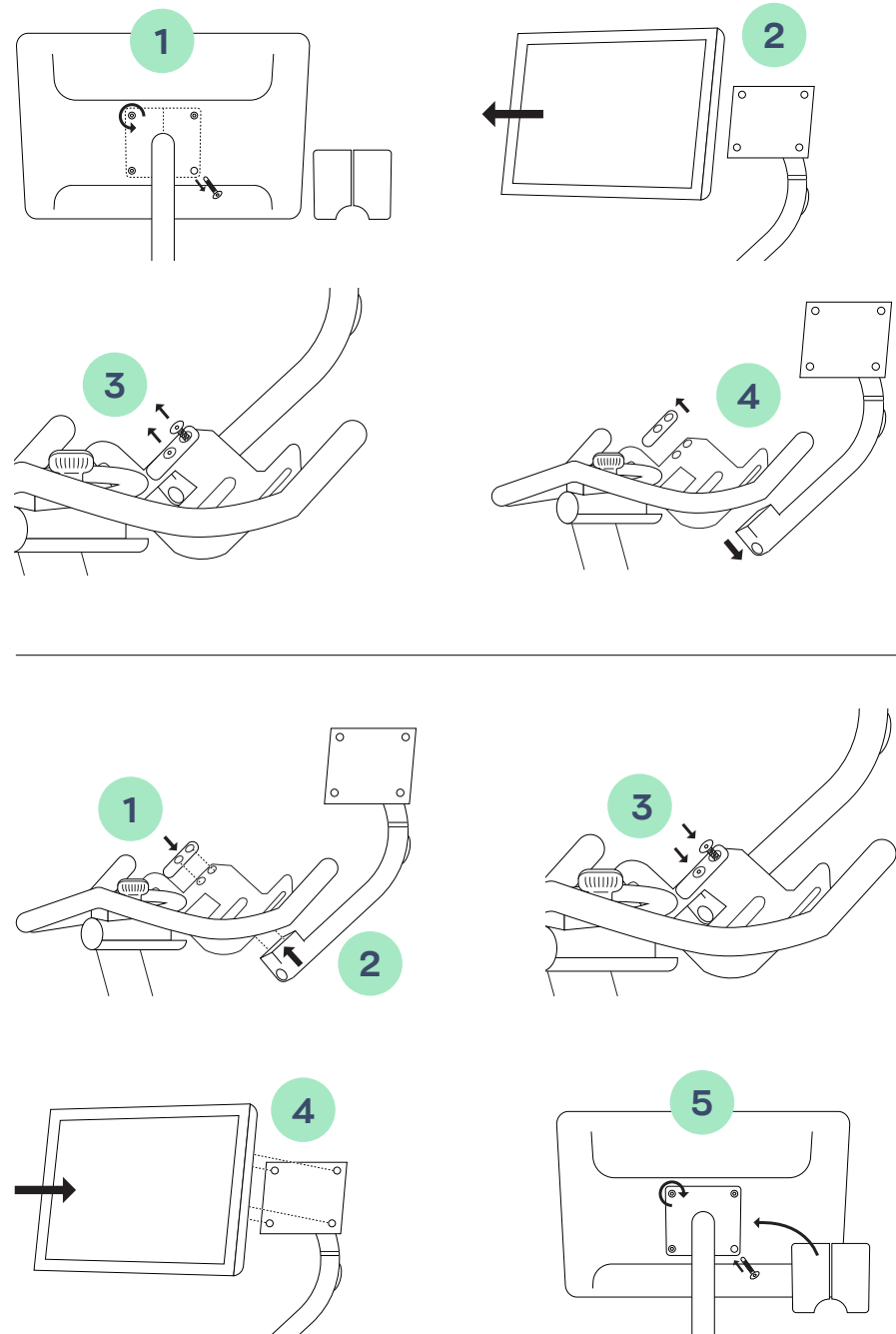

CONNECT POWER CORD

Thread the small end of the power cord from the bottom of the mounting arm to the hole at the bend in the arm. Pull the wire through the hole and connect to tablet, allowing 8-10" of slack so the tablet can swivel freely. Connect the wall adapter to the plug below the flywheel and a grounded 120V wall outlet.

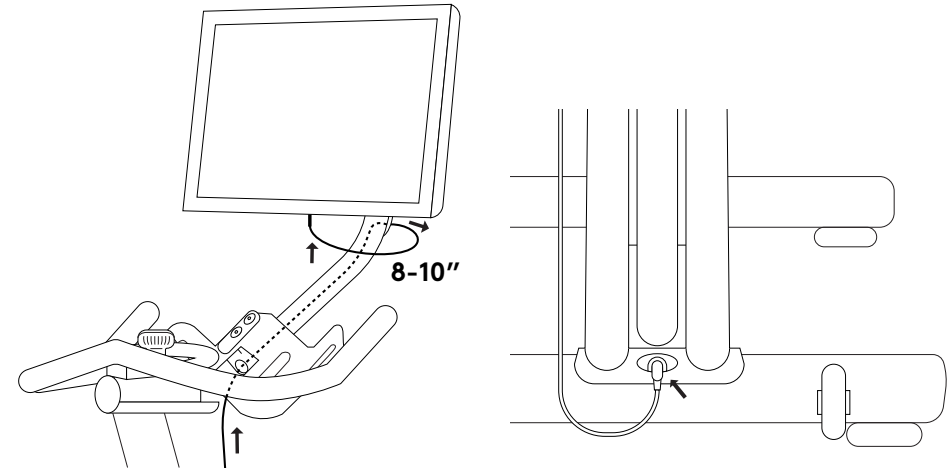

ADJUSTING SEAT AND HANDLEBAR HEIGHT

Seat and handlebars can be raised and lowered with the adjustment pins at the front and rear of the bike frame, shown in the diagram on page 6.

⚠ CAUTION Adjust the seat and handlebars with two people due to the weight of the handlebars with tablet attached.

1. Turn pins counterclockwise to unscrew.
2. If adjusting the handlebars, have your assistant support the weight of the handlebars from beneath.
3. Pull the pin outward and have raise or lower the post.
4. Release the pin so it locks into the post at the desired height, and tighten the knob to secure it in place.

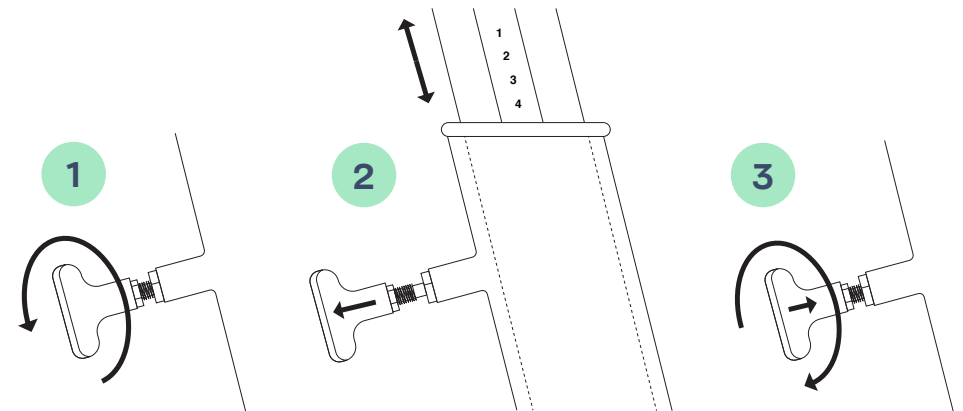

⚠ CAUTION Do not lift the seat or handlebar posts above the MAX mark.

⚠ CAUTION Do not use the product if the seat or handlebars are not securely and tightly locked into place.

⚠ CAUTION Ensure power cord is out of the way when adjusting the height.

ADJUSTING SEAT AND HANDLEBAR DEPTH

Seat Depth

1. Loosen the knob under the seat slider by turning it clockwise, as shown in the diagram.
2. Push the seat forward or backward to adjust position, and tighten the knob to secure into place.

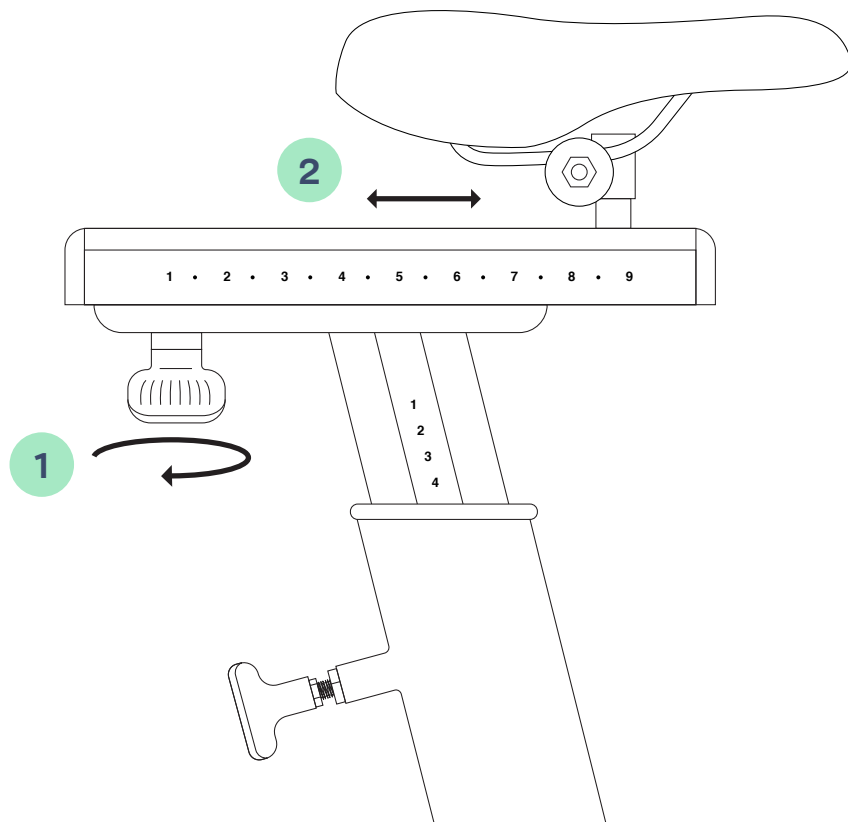

Handlebar Depth

1. Loosen the knob between the handlebars by turning it counterclockwise, as shown in the diagram.
2. While supporting the weight of the tablet arm with one hand, slide the handlebars forward or backward to adjust position.
3. Tighten the knob to secure into place.

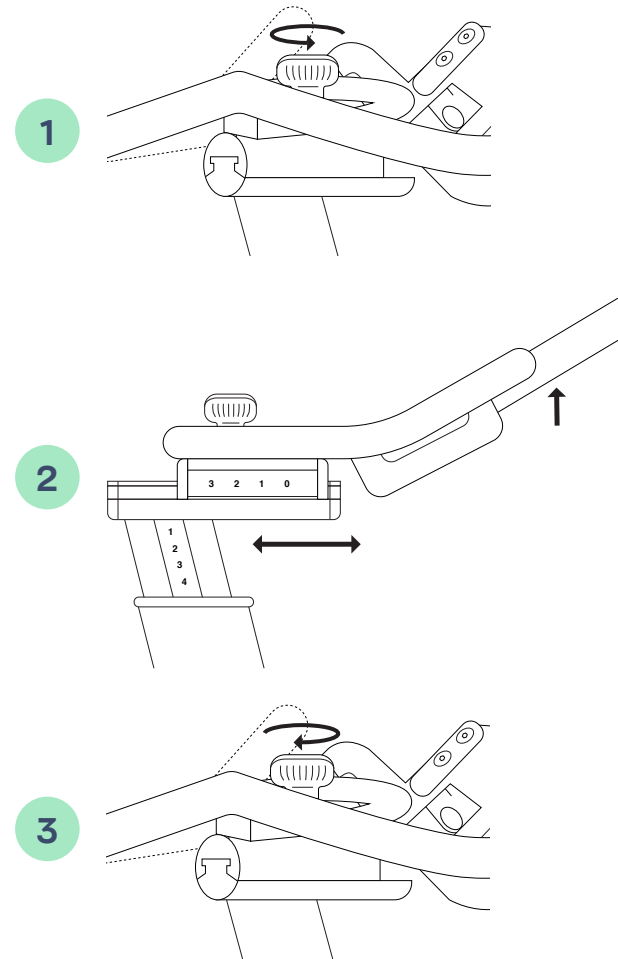

MOUNT AND DISMOUNT

⚠ WARNING To avoid injury or death, the following procedures must be followed to safely mount and dismount the product. Do not mount or dismount the product (or remove your feet from the pedals) until both the pedals and flywheel have come to a complete stop. Mounting or dismounting while pedals are moving can seriously injure user.

To mount the product safely:

1. Verify the product is fully stopped and pedals are completely stopped.
2. Grasp handlebar and step carefully onto pedals.

To dismount the product safely:

1. Wait until the pedals and flywheel come to a complete stop. Stop the pedals using ANY of the following methods:
 - Slow your pedaling until the pedals come to a complete stop.
 - Increase the resistance by turning the push brake system knob clockwise (+) until the pedals come to a complete stop.
 - Push down and hold the resistance knob until the pedals come to a complete stop.
2. Once the pedals and flywheel are stopped, remove feet from pedal clips or cages, as applicable.
3. Grasp handlebars firmly for support and carefully step down.

Emergency Dismount:

If an emergency stop and dismount is required:

1. Stop pedaling. The fastest way to stop is to push down and hold the resistance knob until the pedals come to a complete stop.
2. Once the pedals and flywheel are stopped, remove feet from pedal clips or cages, as applicable.
3. Grasp handlebars firmly for support and carefully step down.

ADJUSTING RESISTANCE

The resistance knob is located at the base of the handlebar post (see diagram on page 6). Note that it takes several full turns to feel changes in resistance.

1. Rotate right to increase resistance.
2. Rotate left to decrease resistance.
3. Press down on the knob to stop the flywheel.

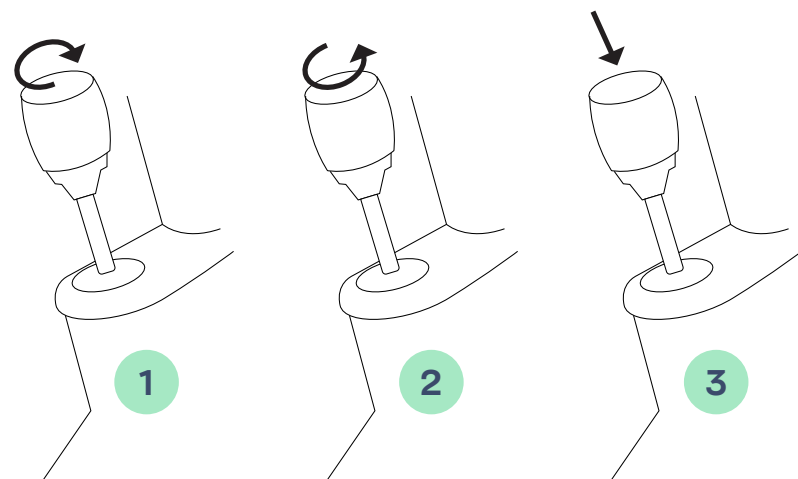

USING PEDAL CLIPS AND CAGE

To use the product with SPD clips:

1. Install the cleats on your SPD-compatible shoes according to the manufacturer's instructions.
2. Make sure the pedal is flat and right-side up (diagram A).
3. Place the cleat on your shoe into the clip and push down.
4. To release the clip, simply twist your heel away from the bike until your shoe disengages from the pedal.

⚠ CAUTION The product is intended to be used with SPD-compatible clips. Do not use any other type of clips.

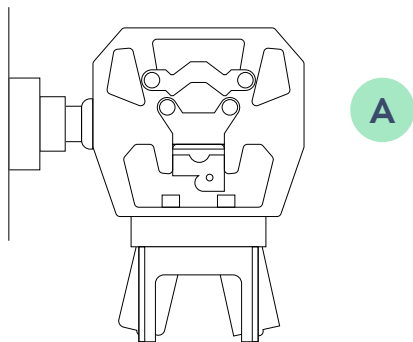

To use the product with cages, you must use athletic shoes:

You'll use the cages on the reverse of the pedal (diagram B).

⚠ CAUTION First, make sure your shoelaces are tied, tucked away and not dangling over your foot.

1. Insert your foot through the cage. Align the ball of your foot (generally the widest part of your shoe) over the center of the pedal, and pull the strap tightly to tighten the cage. Thread the excess strap through the metal clip.
2. Repeat on the other side and you're good to go!
3. To remove your foot, squeeze and release the bottom of the metal clip to release the tension grip and loosen the cages. Then you can slide your foot out of the cage.

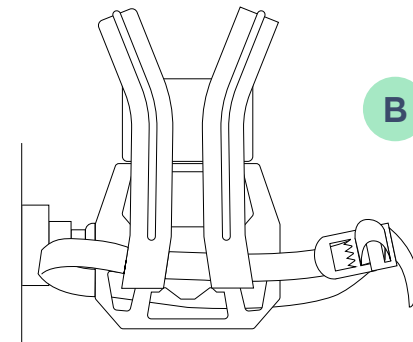

Speed Sensor

(MYX II ONLY)

REPLACE BATTERY

The speed sensor is located on the inner side of the left pedal crank. When the app indicates the sensor battery is low, replace it with a new CR-2032 coin cell battery. Expected battery life is 100 hours.

1. Turn the battery cover counter clockwise to open.
2. Remove the old battery from the metal holder and replace it with a new battery. Make sure the negative side faces up (toward the battery cover).
3. Replace the battery cover. Align it in the top slot, then turn clockwise using your fingernail in the groove to guide it. LED lights will flash to indicate the battery has proper placement.

TUNE YOUR SENSOR

If you have trouble with speed, cadence or distance tracking you can follow instructions within the tablet app to re-tune your sensor.

WAKE YOUR SENSOR

Pedal for two minutes to wake the speed sensor.

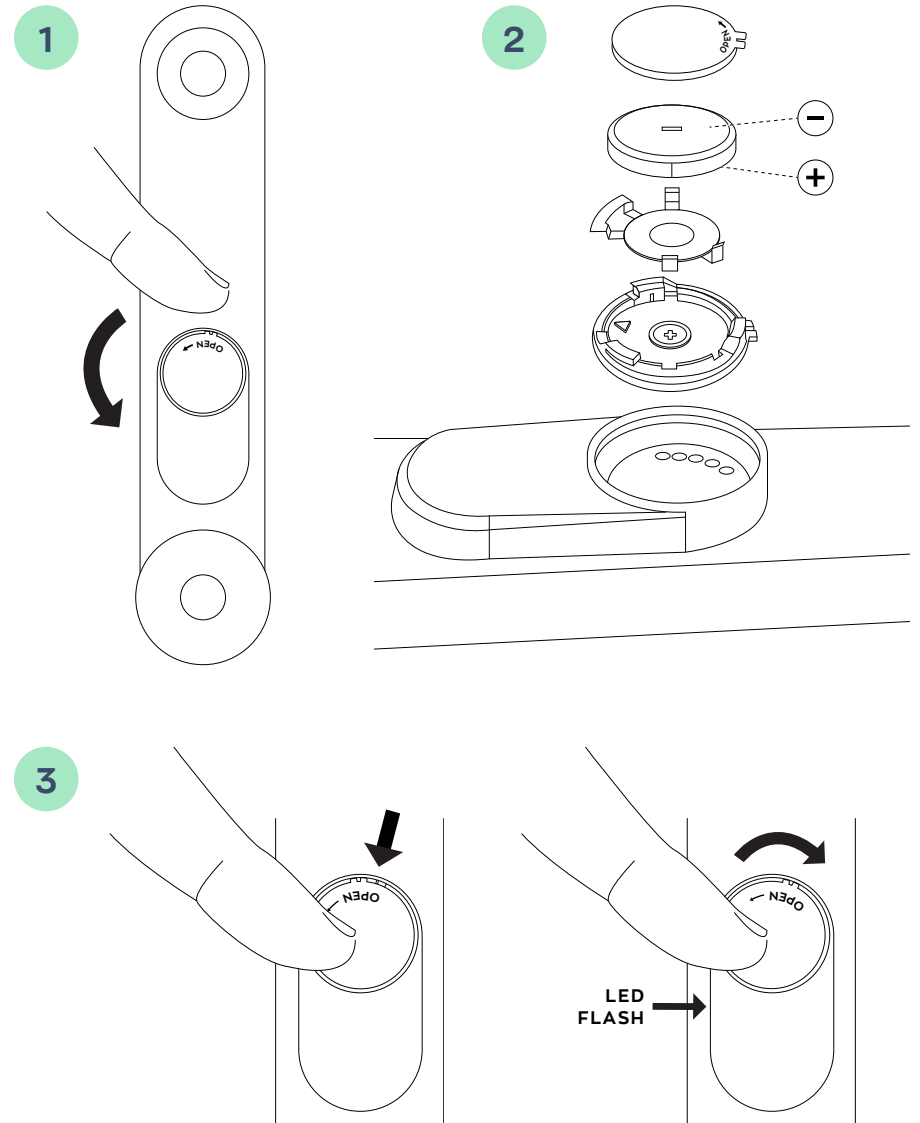

Heart Rate Monitor Setup

CHARGE BATTERY

A red light indicates your heart rate monitor needs to be charged.

1. Place the OH1 sensor into the USB-A adapter so that the metal contacts meet.
2. Insert the adapter into the dongle, then plug the small end into the USB-C port at rear of the tablet. Check for the orange light which indicates the USB has been inserted correctly. For MYX II, insert the adapter into the dongle.

A flashing yellow light indicates it is charging. A green light indicates that it is fully charged.

USING YOUR HEART RATE MONITOR

1. Remove the sensor from the charging adaptor, and place it in the holder on the arm band so the sensing side is exposed.
2. Put the arm band on your upper forearm or bicep so that the sensor touches your skin.
3. Press the silver button once to turn on. A blinking green light means it has detected your heartbeat.
4. Choose a workout on the MYX tablet. At the top right of the workout details screen, choose Tap to Pair “HR Monitor”. Your heart rate monitor can also be paired by pressing the heart-shaped icon during a workout.
5. After your workout, press and hold the OH1 button to turn off the heart rate monitor.

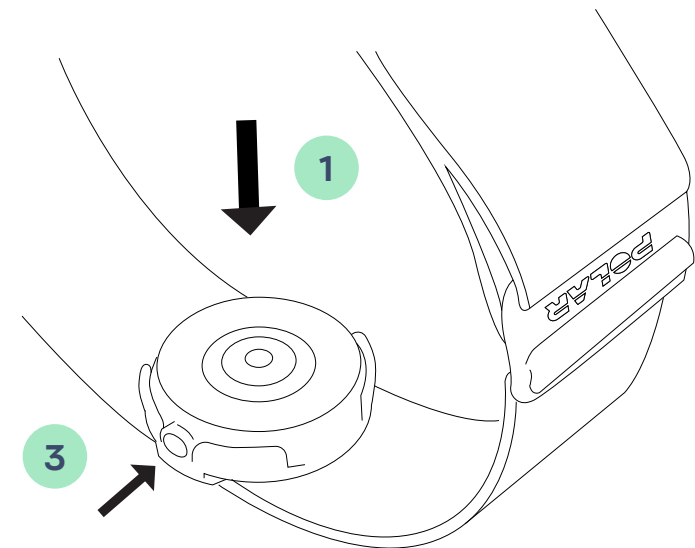
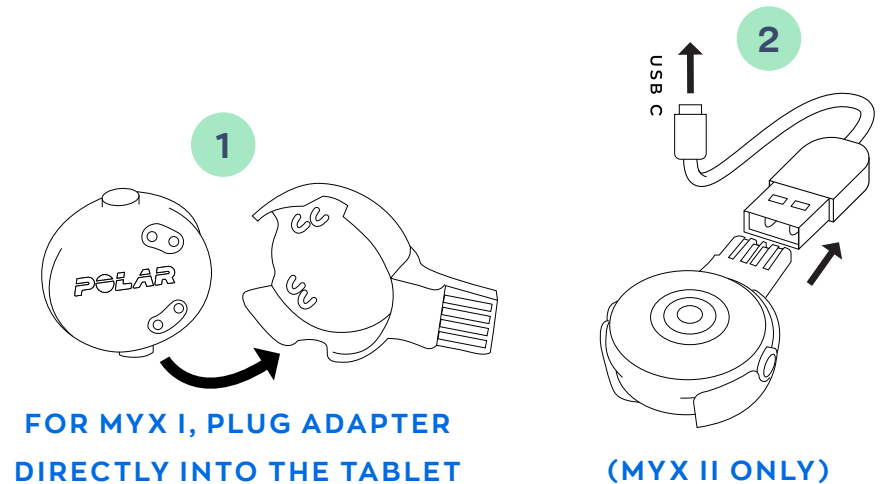

⚠ WARNING Please consult your physician before engaging in heart rate training, especially if you are pregnant, are younger than 18 years old, have any underlying medical conditions, or are unsure about pushing your heart rate to the max. If you are younger than 18 years old, please also get your parent or guardian's permission before beginning.

Tablet Setup

POWERING ON THE TABLET

Ensure the tablet is connected to an appropriate power source. Press and hold the power button on the right side of the tablet for five seconds to power on.

To enter or exit sleep mode, quickly press the power button.

To turn off the tablet, press and hold the power button for one second, and select Power Off on the screen.

CONNECTING TO INTERNET

A strong internet connection with a minimum download speed of 10-15 MBPS is required to stream MYXfitness content. After powering on your device, follow the on screen instructions to select your wireless network.

To use ethernet, run an ethernet cord from your router to the leftmost port at the bottom of the tablet, and your device should automatically join the network.

⚠ WARNING Ensure the Ethernet cord does not interfere with you, your exercise or the product. For example, ensure the cord does not interfere with any moving parts, such as the flywheel or pedals.

Caring for Your MYX

MAINTENANCE

Preventative maintenance can extend the life of your product and significantly reduce equipment failures. The chart provided is our recommended maintenance schedule. It is your responsibility to ensure that regular maintenance is performed.

⚠️ WARNING Worn or damaged parts must be replaced immediately, and should not be used until the repair is made.

CLEANING

We recommend wiping down and cleaning the product frame daily. For a deeper clean use water with a non-abrasive soap, car wash soap, or bike cleaner. Wipe with water and dry. Avoid spraying any liquids directly onto the product. Instead, spray onto a clean towel first then wipe the product. You may also seal the frame with wax or bike polish.

CHECKLIST

WEEKLY MONTHLY

Inspect for loose nuts or bolts on handlebar and seat assembly and tighten as necessary.	×	
Verify that pedal bolts connecting pedals to bike crank are tight after the first 10 hours of use and every 100 hours of use thereafter. Tighten (clockwise) with a 15mm box wrench.	×	
Inspect pedals for excessive wobble or side-to-side movement. If loose, they need to be replaced.		×
Check flywheel alignment. Realign flywheel nuts as necessary.		×
Tighten seat hardware (bolt connecting seat to post)		×
Lubricate horizontal and vertical sliders (for seat and handlebars) with dry film lubricant with PTFE or wet film lubricant with PTFE. Apply a layer and use a cloth to clean up excess.		×
Inspect welds for any signs of cracking		×
Inspect leveling feet		×
Check for rust and remove any minor buildup found using a small brush.		×
Inspect the seat for wear and tear. Rips, tears, or excessive movement indicate the seat needs to be replaced.		×
Inspect pedal toe clips and straps for any looseness or excessive wear. Replace if toe clips cannot be tightened to pedal or if the strap shows excessive wear.		×

Caring for Your MYX

WARNINGS AND CAUTIONS

To replace any worn or damaged decals contact customer support to order new labels:

help@myxfitness.com

WARNING



Read the Owner's Manual and follow all proper instruction prior to use.

IMPROPER USE OF THIS MACHINE CAN RESULT IN SERIOUS INJURY.

1. As with all exercise equipment or programs, consult a physician prior to use and stop if you feel faint, dizzy or exhausted.
2. This equipment should only be used in a supervised environment.
3. Keep children away from bike.
4. Inspect machine prior to use. Immediately report worn, loose or damaged equipment to the Instructor and refrain from using the bike.
5. Keep body and clothing free and clear of all moving parts.
6. Ensure all adjustment and locking features are properly secured before using bike.
7. Always ride in control. Stop in a controlled manner as flywheel momentum will keep pedals turning.
8. Maximum user capacity is 350 lbs (158.8 Kg).
9. Verify that pedals connecting to the bike cranks are tight after the first 10 hours of use and every 100 hours of use thereafter. Tighten each pedal to a torque of 33-37 ft-lbs.
10. Replace label if damaged, illegible or removed.

WARNING

LEFT CRANK: Tighten pedal marked "L" to 33-37 ft lbs. After the first 10 hours of use and every 100 hours of use thereafter, re-tighten pedal to a torque of 33-37 ft-lbs.

WARNING

RIGHT CRANK: Tighten pedal marked "R" to 33-37 ft lbs. After the first 10 hours of use and every 100 hours of use thereafter, re-tighten pedal to a torque of 33-37 ft-lbs.

Limited Product Warranty

MYX FITNESS® EXERCISE BIKE LIMITED PRODUCT WARRANTY

1. WARRANTY OVERVIEW

The Myx Fitness exercise bike (the “Myx Fitness Bike”) you have purchased from Myx Fitness, LLC (“Myx Fitness”) either alone or with Myx Fitness home studio accessories (“Accessories”) comes with a limited product warranty (the “Limited Product Warranty”) covering only the Myx Fitness Bike, Accessories, software of any kind (excluding music functionality and selection) embedded in your Myx Fitness tablet that is a component of your Myx Fitness Bike (“Product Firmware”), and the components of the Myx Fitness Bike expressly described below, and which can be identified by the Myx Fitness trademark, trade name, or logo annexed or affixed to such items (other than Product Firmware), for the period of time set forth below. The Myx Fitness Bike, Accessories, Product Firmware and the components of the Myx Fitness Bike expressly described below are collectively referred to in this Limited Product Warranty as, “Product.”

This Limited Product Warranty is valid only if: (i) you use the Product within a private, in-home, domestic, indoor, non-commercial environment and in accordance with the Myx Fitness Bike product manual, unless otherwise approved in advance in writing by Myx Fitness; and (ii) you are in good standing and in compliance with the Myx Fitness Terms and Conditions available on the

Myx Fitness website (<https://www.myxfitness.com/terms-of-service>). Certain other exclusions apply, as further described in this Limited Product Warranty.

This Limited Product Warranty is non-transferable and is only valid for the original purchaser of the Myx Fitness Bike, or for a Myx Fitness Bike gifted at the time of purchase, the member of the original membership first used to access and use live and on demand exercise content on that specific Myx Fitness Bike.

The Limited Product Warranty applies as follows:

A. Accessories – 12 Months. Myx Fitness warrants the Accessories that you purchased directly from Myx Fitness with your Myx Fitness Bike against defects in workmanship and materials for a period of 12 months from the date of original delivery. Such Accessories may include dumbbells, kettle bell, stabilizing mat, yoga mat, heart rate monitor, foam roller and/or resistance band.

B. Product Firmware – 12 Months. Myx Fitness warrants the Product Firmware against material defects that cannot be corrected or repaired remotely by Myx Fitness for a period of 12 months from the date of original delivery.

C. HD Touchscreen of Interactive Tablet – 12 Months. Myx Fitness warrants the touchscreen against defects in workmanship and materials for a period of 12 months from the date of original delivery.

D. Structural Frame – 5 Years. Myx Fitness warrants the structural frame components (excluding any moving parts attached to the structural frame) against defects in workmanship and materials for a period of 5 years from the date of original delivery.

E. Bike Components – 12 Months. Myx Fitness warrants the components and all original parts of the Myx Fitness Bike (other than pedals), including its flywheel, belt, brake resistance, crank shaft, seatpost, handlebars and water bottle holder, against defects in workmanship and materials for a period of 12 months from the date of original delivery.

F. Bike Pedals – 12 Months. Myx Fitness warrants the components and all original parts of the original pedals that come with the Myx Fitness Bike against defects in workmanship and materials for a period of 12 months from the date of original delivery. Bike pedals are not warranted against normal wear and tear and it is important that you maintain the pedals by inspecting them regularly for any damage, loose parts or other signs of wear and tear that could cause breakdowns or part failures. Any pedal that shows signs of worn or damaged parts should be removed from service immediately. Please refer to the Myx Fitness Help Center on maintaining your gear, available on Myx Fitness’s website.

G. Labor – 12 Months. For Myx Fitness Bikes originally assembled by an authorized Myx Fitness technician, Myx Fitness will cover the labor cost for the repair or replacement made under this Limited Product Warranty for a period of 12 months from the date of

original delivery. Except where applicable law requires otherwise, repair labor is not covered for locations where Myx Fitness did not originally assemble the Myx Fitness Bike or if the Myx Fitness Bike is moved to a location that is outside of Myx Fitness's service area. Any attempt to move or repair fitness equipment creates a risk of injury and property damage. All moves or repairs attempted by you or your agents are undertaken AT YOUR OWN RISK and none of the Myx Fitness Parties (as defined below) will have any liability for any injury to persons or property arising from such attempted moves or repairs.

If (a) a defect in material or workmanship arises with your Myx Fitness Bike, Accessories, or any of the components thereof (described above) or a material defect that cannot be corrected or repaired remotely by Myx Fitness arises with your Product Firmware, (b) your Product has been used in accordance with the terms and conditions of this Limited Product Warranty, (c) a valid Limited Product Warranty claim is received by Myx Fitness within the applicable warranty period set forth above in accordance with the terms of this Limited Product Warranty, and (d) you are in good standing and in compliance with the Myx Fitness Terms and Conditions available on the Myx Fitness website (<https://www.myxfitness.com/terms-of-service>), Myx Fitness will, in its sole and absolute discretion and to the extent permitted by applicable law, either repair or replace, at its option, the applicable defective Product component (e.g., Myx Fitness Bike, Accessory, Product Firmware or other applicable component thereof) with one that is new or equivalent to new (i.e., refurbished) in performance and reliability and is at least functionally equivalent to the

original Product component.

Where permitted by law, replacement units, parts and electronic components reconditioned to as-new condition by Myx Fitness or its vendors may sometimes be supplied as warranty replacement and constitute fulfillment of warranty terms.

If the defective Product component is shipped to a service center, freight charges to and from the service center may be your responsibility. For replacement parts shipped while the Product is under warranty, you may be responsible for a minimal handling charge. For in-home service while the Product is under warranty, you may be responsible for a minimal trip charge. MYX FITNESS DOES NOT PROVIDE MONETARY OR OTHER COMPENSATION FOR ANY REPAIRS OR REPLACEMENT PART COSTS IN CONNECTION WITH THE PRODUCT, INCLUDING WITHOUT LIMITATION, MEMBERSHIP FEES, WORKOUT TIME LOST, COST OF SUBSTITUTE EQUIPMENT, DIAGNOSTIC VISITS, MAINTENANCE VISITS OR TRANSPORTATION.

Any replacement or repaired Product will be warranted for the remainder of the original applicable Limited Product Warranty period or 30 days, whichever is longer, or for any additional period that is required by applicable law.

No other warranty beyond that specifically set forth above is authorized by Myx Fitness.

2. EXCLUSIONS AND LIMITATIONS

This Limited Product Warranty does not extend to and may be voided by Myx Fitness in its sole and absolute discretion for any of the following:

A. Any damage to the Product used for commercial or rental purposes, as store display models, or for any use other than in a single-family household, unless such use has been approved in advance in writing by Myx Fitness.

B. Any Myx Fitness products or services other than those expressly described in this Limited Product Warranty; non-Myx Fitness products or labor; Products that are, or that Myx Fitness reasonably believes to be, stolen, counterfeit, or purchased from an unauthorized distributor or reseller; Products transported, purchased or used outside the country to which Myx Fitness originally shipped the Product (for the United States, warranty claims are currently only valid in the continental United States); and/or Products missing serial numbers.

C. Any software or firmware, other than the Product Firmware, even if sold with or embedded in the Myx Fitness Bike or any of the components therein, or Internet or wireless connectivity.

D. Any damage to the Product caused by accident, abuse, misuse or use for any purpose other than its intended purpose. In particular, for purposes of illustration and without limitation, this Limited Product Warranty does not apply: (i) to damage or defects caused by customer or other third-party abuse, accident, neglect, abuse, misuse, improper handling, utilization, maintenance, assembly, or installation; (ii) to damage or defects caused by tampering of any kind; (iii) to damage caused by normal wear and tear, including but not limited to, cosmetic damage, scratches, dents, discoloration or paint or plastic, broken plastic on parts, any physical damage to the surface of the Product (or any other change in cosmetic appearance that does not affect

performance); (iv) to damage or defects caused by the Product being used with or connected to an accessory or component not approved or certified by Myx Fitness,

or any use contrary to the instruction in the product manual or Myx Fitness Website or Help Center; (v) to damage or defects caused by flood, fire, earthquake, wind, lightning, freezing or other natural disasters, theft, vandalism, electrical wiring, power reduction, power fluctuation or power failure from whatever cause, or other external causes beyond the reasonable control of Myx Fitness; (vi) if any serial number has been removed or defaced; or (vii) to a recalled Product component, if Myx Fitness provided reasonable notice of a recall and made replacements of the recalled Product component, as relevant, available to its customers.

E. Any damage or equipment failure (viii) caused by the opening of the Myx Fitness Bike, or to service or repairs performed, by anyone who is not a representative of Myx Fitness or a Myx Fitness authorized retailer or service provider; or (ix) where the Product has been altered or modified in any manner by anyone who is not a representative of Myx Fitness or a Myx Fitness authorized retailer or service provider or without the written permission of Myx Fitness.

Myx Fitness does not warrant that the use and/or operation of the Product will be uninterrupted or error free. In addition, although Myx Fitness may provide periodic updates to the Product Firmware, this Limited Product Warranty does not apply in the event that any Product Firmware needs to be upgraded for any reason. This Limited Product Warranty does not cover any loss, damage or defects caused by a defective function of any wireless network or if any Product Firmware needs to be upgraded due

to changes in wireless network parameters.

THIS LIMITED PRODUCT WARRANTY IS THE EXCLUSIVE WARRANTY GIVEN BY MYX FITNESS FOR THE PRODUCT AND SUPERSEDES ANY PRIOR, CONTRARY OR ADDITIONAL WARRANTIES OR REPRESENTATIONS. EXCEPT FOR THE WARRANTIES EXPRESSLY PROVIDED UNDER THIS LIMITED PRODUCT WARRANTY, ALL OTHER WARRANTIES, EXPRESS, IMPLIED OR STATUTORY, WITH RESPECT TO THE PRODUCT, WHETHER AS TO CONDITION OF MERCHANTABILITY, FITNESS FOR A PARTICULAR PURPOSE, NON-INFRINGEMENT, TITLE, QUIET ENJOYMENT OR ANY OTHER MATTER, ARE DISCLAIMED, EXCEPT TO THE EXTENT PROHIBITED BY LAW. IN SUCH EVENT, SUCH WARRANTY IS LIMITED TO THE DURATION OF THE WARRANTY PERIODS SET FORTH ABOVE. THIS EXCLUSION APPLIES EVEN IF THIS WARRANTY FAILS OF ITS ESSENTIAL PURPOSES AND REGARDLESS OF WHETHER DAMAGES ARE SOUGHT FOR BREACH OF WARRANTY, BREACH OF CONTRACT, NEGLIGENCE, OR STRICT LIABILITY IN TORT OR UNDER ANY OTHER LEGAL THEORY.

THE REMEDIES SET FORTH IN THIS MYX FITNESS LIMITED PRODUCT WARRANTY WILL BE THE SOLE AND EXCLUSIVE REMEDIES AVAILABLE TO ANY PERSON OR ENTITY.

UNDER NO CIRCUMSTANCES WILL MYX FITNESS, ITS PARENT COMPANY, SUBSIDIARIES, AFFILIATES, MANUFACTURERS, SERVICE PROVIDERS, LICENSORS, DISTRIBUTORS, SUPPLIERS AND EACH OF ITS AND THEIR RESPECTIVE PARENT COMPANIES, SUBSIDIARIES, AFFILIATES, OFFICERS, DIRECTORS, MANAGERS, PARTNERS, MEMBERS, SUCCESSORS AND ASSIGNS (COLLECTIVELY, THE "MYX FITNESS PARTIES") BE SUBJECT

TO ANY CONSEQUENTIAL, INCIDENTAL, INDIRECT, SPECIAL, EXEMPLARY, PUNITIVE OR CONTINGENT DAMAGES WHATSOEVER, RELATED TO OR ARISING OUT OF THIS LIMITED PRODUCT WARRANTY OR THE USE OF THE PRODUCT, WHETHER BASED ON CONTRACT, TORT, STRICT LIABILITY OR OTHER THEORY OF LAW, ALL SUCH DAMAGES AND CLAIMS BEING SPECIFICALLY DISCLAIMED.

ANY DISPUTES BETWEEN YOU AND MYX FITNESS RELATED TO THIS LIMITED PRODUCT WARRANTY OR THE PRODUCT WILL BE GOVERNED BY THE THEN-CURRENT DISPUTE RESOLUTION PROCEDURES IN THE MYX FITNESS TERMS AND CONDITIONS, AVAILABLE AT (<https://www.myxfitness.com/terms-of-service>).

NOTWITHSTANDING ANY DAMAGES THAT YOU MIGHT INCUR FOR ANY REASON WHATSOEVER (INCLUDING, WITHOUT LIMITATION, ALL DAMAGES REFERENCED HEREIN AND ALL DIRECT OR GENERAL DAMAGES IN CONTRACT, TORT (INCLUDING, WITHOUT LIMITATION, NEGLIGENCE) OR OTHERWISE, THE ENTIRE AGGREGATE LIABILITY OF THE MYX FITNESS PARTIES WILL BE LIMITED TO THE AMOUNT ACTUALLY PAID BY YOU FOR THE PRODUCT (BUT EXCLUDING ALL AMOUNTS PAID FOR THE ONGOING MEMBERSHIP) GIVING RISE TO LIABILITY.

Without limiting any of the foregoing and in addition thereto, in no event, under any cause of action or theory of liability, will the Myx Fitness Parties be liable to you or any third party for any (a) accident, personal injury or death or property damage or any other claims, losses, costs or damages, related to, arising out of or resulting from the purchase, sale, use of or inability to use the Product, or the performance or provision of services by Myx Fitness pursuant to this 21

Limited Product Warranty or otherwise, the loss of value of the Product or any third party accessories, services, products or devices that are used in or with the Product, or the loss of use of the Product or any third party accessories, services, products or devices that are used in or with the Product, even if any Myx Fitness Party has been advised of the possibility of such damages; (b) damage or destruction to consumer electronics devices or other personal property that are contained inside or outside, or used in connection with, the Product, including, without limitation, mobile apps, tablets, laptops, cellular phones, or other handheld devices, or for any loss of data stored in the foregoing devices or elsewhere; and (c) costs or damages arising from or related to your breach of the terms of this Limited Product Warranty. The Myx Fitness Parties disclaim any representation that they will be able to repair any product under this Limited Product Warranty or make a product exchange without risk to or loss of electronic information, including programs or data.

The foregoing limitations of liability constitute an essential part of this Limited Product Warranty. In some jurisdictions, under some circumstances, the limitations and disclaimers of liability contained in this Limited Product Warranty do not apply to claims involving personal injury, claims of wrongful death, claims of damage to property or to statutory liability for intentional or grossly negligent acts and/or omissions. Some States do not allow the exclusion or limitation of incidental or consequential damages, so the above limitation or exclusion may not apply to you. Nevertheless, Myx Fitness intends that the limitations and disclaimers of liability contained in this Limited Product Warranty will apply to the maximum extent

allowed under applicable law. If applicable law specifies a minimum warranty period that is longer than the applicable warranty periods set forth in the terms and conditions of this Limited Product Warranty, then the warranty period for the applicable Product component subject to such applicable law will be conformed to the minimum legally required warranty period. The limitations and disclaimers of liability set forth in this Limited Product Warranty survive the expiration or termination of the warranty periods set forth in this Limited Product Warranty and apply notwithstanding any contrary provision in this Limited Product Warranty. This warranty gives you specific legal rights, and you may also have other rights which vary from State to State.

3. WARRANTY CLAIMS AND QUESTIONS

To be eligible for service under this Limited Product Warranty you must provide Myx Fitness with the serial number of your Myx Fitness Bike and the dated receipt, or other proof of purchase indicating the date purchased, upon discovering any defect. Claims must be made within the specified warranty periods listed above.

To file a warranty claim, or for any questions or concerns, please contact member support by emailing us at help@myxfitness.com for fastest service and response time.

You may also write to us at:

Myx Fitness, LLC
Attention: Limited Product Warranty Claims
3301 Exposition Blvd.
Santa Monica, California 90404

Rev: August 27, 2021

Appendix

WARRANTY INFORMATION

Visit myxfitness.com/warranty

CONTACT

Help Center

help.myxfitness.com

Customer Support

help@myxfitness.com

Myx Fitness, LLC

3301 Exposition Blvd.

Santa Monica, CA 90404

Please supply the serial number of your machine and the date of purchase when you contact us. The serial number is found under the rear leg of the machine (see diagram on page 6.)