

Huawei Technologies Deutschland GmbH
SUN2000 Series

Huawei Inverter Review

August 2016



Executive Summary

SgurrEnergy Ltd has been commissioned by Huawei Technologies Deutschland GmbH to undertake a detailed independent technical assessment of the SUN2000 series string inverters. This report is for Huawei's use in providing lenders, insurers or customers with the technical information and independent analysis that is required for their assessment of the SUN2000 inverters.

SgurrEnergy has conducted a review of the Huawei SUN2000 series string inverter based on information provided by Huawei through a combination of technical documentation, factory inspections, interviews of key technical and management staff and technical query correspondence.

The review revealed that Huawei is a major global manufacturer of telecommunications equipment and has recently entered the solar inverter manufacturing segment. Huawei inverters have been used on a significant number of MW-scale solar projects around the world, notably in China, the UK and India.

The review revealed that the design of the inverter provides a safe and efficient means of converting DC power to AC. The inclusion of two or three model dependant MPPTs increases the efficiency of the inverter in multiple operational environments such as shading, different string output powers, different modules and varied tilt angles. Confirmation of maximum DC system input levels for the inverter is in line with leading inverter manufacturers.

The TA believes that the policy of utilising quality assured manufacturers for key components results in acceptable product quality. A large number of components are manufactured in China with the remainder manufactured by established manufacturers with strong supply chains.

The TA considers the published performance figures to be at the upper range of current industry performance. These have been confirmed by independent testing by industry experts Photon who rated the SUN2000 20kTL as A+. This is one of only 4 inverters to have received this award.

Huawei has well-established quality, environmental, health and safety management processes in place based on an extensive history in manufacturing electronic components. Huawei has industry standard certification including ISO 9001, ISO 14001 and OHSAS 18001. The TA observed EHS procedures were adhered to during a factory inspection.

The TA considers the manufacturing process of the SUN2000 series inverters to be well-designed with appropriate quality management processes ensuring each stage is conducted to a high standard. Staff on the production line appear capable and finished inverters were good quality.



With a list of all third-party certifications for different inverter models, the TA considers the Huawei SUN2000 series string inverter to have the required certification for use on PV plants in various countries in Europe, Asia, North America, Africa and Oceania. In-house testing of the inverter and individual components is relatively extensive during the R&D phase with each inverter then functionally tested along with short-term high-temperature condition testing.

A MTBF analysis was undertaken by Huawei with an expected design life stated by Huawei greater than 20 years. A deployment failure rate of approximately 0.5% for the inverter models in Asia and Europe is considered acceptable. Warranty conditions can be considered in line with market standard and offer customer-centric services.

Whilst inverters are typically expected to last for at least half the project lifetime of a PV plant (25 years), considering a bathtub failure rate and relatively low current failure rate for the initial period, as well as accelerated lifetime tests completed on the inverters, the TA is satisfied that the inverters have a good level of reliability. Nonetheless, the TA recommends that Huawei regularly update the installation and user manual in order to minimise inverter faults caused by improper installation and operation and continue to conduct additional accelerated lifetime testing.

Operational data for a single inverter installation in Germany since February 2014 indicates the inverter performance is comparable with leading inverter manufacturers both in terms of performance and availability. Operational data provided for large-scale installations also indicate proven performance.

Overall, considering the inverters have not been in production for a significant period of time, the TA concludes that the reliability of Huawei inverters is reasonably well proven, with a significant amount of data provided for review, including operational data and overall recorded failure rates.



Report Details

Prepared for:	Huawei Technologies Deutschland GmbH
Client Contact:	Alison Finch
Report Distribution:	
Huawei Technologies Deutschland GmbH:	Guoguang Chen
SgurrEnergy:	Raphael Raggatt
Report Classification:	Confidential

SF/04/023

NOTICE

This document entitled "*Huawei Inverter Review*", document number 14/7447/001/BEI/O/R/001 B8 has been prepared solely for Huawei Technologies Deutschland GmbH in connection with SUN2000 Series. This document in whole or in part may not be used by any person for any purpose other than that specified, without the express written permission of SgurrEnergy.

Any liability arising out of use by a third party of this document for purposes not wholly connected with the above shall be the responsibility of that party who shall indemnify SgurrEnergy against all claims, costs damages and losses arising out of such use.



Contents

1	Introduction.....	9
2	Company Overview	10
2.1	Company Background	10
2.2	Huawei Inverter Global Team and Huawei Smart PV Solution	11
2.3	Experience and Track Record.....	12
2.4	Summary	16
3	Technical Characteristics	16
3.1	Product & Solution Portfolio	16
3.2	Technical Specifications	18
3.2.1	Overview.....	21
3.2.2	Inverter circuit layout.....	25
3.2.3	Inverter Components	26
3.3	Performance	29
3.3.1	Efficiency	29
3.3.2	MPPT.....	31
3.3.3	Summary of performance.....	31
4	Compliance to International Grid Standards	32
5	Quality, Environmental, Health and Safety Procedures	38
5.1	Certification.....	38
5.2	QHSE Management.....	39
5.2.1	Quality Management.....	39
5.2.2	Environmental Management	40
5.2.3	Health and Safety Management.....	41
5.3	Certification.....	41
5.3.1	Summary	45
6	Manufacturing Processes	45
6.1	Pre-Assembly Stage	46
6.2	Inverter Assembly Process	47
6.2.1	PCBA Process	47
6.2.2	Unit Assembly Process	48



6.3	Final Testing and Packing.....	49
6.4	Production Capacity.....	50
6.5	Summary	51
7	Performance and Reliability.....	51
7.1	Testing.....	51
7.1.1	In-house Testing	51
7.1.2	Independent Testing	55
7.2	Operational and Long-term Performance.....	56
7.2.1	Operational Review.....	56
7.2.2	Inverter Failure.....	58
7.3	Warranties and Guarantees.....	62
7.4	Huawei Technical Support	64
7.5	Summary	65
8	Conclusions.....	65
8.1	Company Overview	65
8.2	Technical Characteristics.....	66
8.3	Compliance to International Grid Standards.....	66
8.4	EHS and Manufacturing Processes	66
8.5	Reliability Review.....	67
Appendix A: Photon International Inverter Test Results.....		A-1



Glossary

Abbreviation or Term	Definition
A	Ampere
AC	Alternating Current
CE	Conformité Européenne
dB	decibel
DC	Direct Current
E2E	End to End
EMC	Electromagnetic Compatibility
EMI	Electromagnetic Interference
EMS	Electronic Manufacturing Services
EN	European Norm
HALT	Highly Accelerated Life Test
HTOL	High Temperature Operating Life
HV	High Voltage
Hz	Hertz
IEC	International Electrotechnical Commission
IGBT	Insulated Gate Bipolar Transistor
IOT	Internet of Things
IP	International Protection Rating or Internet Protocol
ISO	International Standards Organisation
LCD	Liquid Crystal Display
LED	Light Emitting Diode



Abbreviation or Term	Definition
LLT	Length of Lifetime Test
LV	Low Voltage
MES	Manufacturing Execution System
MPP	Maximum Power Point
MPPT	Maximum Power Point Tracking
MTBF	Mean Time Between Failure
OEM	Original Equipment Manufacturer
ORT	Ongoing Reliability Test
OVP	Over Voltage Protection
PCBA	Printed Circuit Board Assembly
PV	Photovoltaic
QA	Quality Assurance
QHSE	Quality, Health, Safety and Environment
REACH	Registration, Evaluation, Authorisation and Restriction of Chemicals
SCADA	Supervisory Control and Data Acquisition
SiC	Silicon Carbide
SMT	Surface Mount Technology
SRS	Storage and Retrieval System
TA	Technical Advisor
THB	Temperature Humidity Bias
THD	Total Harmonic Distribution
TL	Transformer-Less



Abbreviation or Term	Definition
UVP	Ultra-Voltage Protection
V	Volt
Voc	Open Circuit Voltage
W	Watt
WEEE	Waste Electrical and Electronic Equipment
WMS	Warehouse Management System



1 Introduction

SgurrEnergy (the Technical Advisor, TA) was commissioned by Huawei Technologies Deutschland GmbH (the Client or Huawei) to conduct a detailed independent technical review of the SUN2000 series string inverter. The review focuses on the following aspects according to the TA's requirements for suitability of use on solar photovoltaic (PV) projects around the world:

- Company Overview.
- Technical Characteristics.
- Manufacturing Processes.
- Manufacturing Facility Inspection.
- Reliability Review.

The report is based on information provided by Huawei through a combination of technical documentation, factory inspections, interviews of key technical and management staff, analysis of Photon magazine's independent review and technical query correspondence. This report is for Huawei's use in providing lenders, insurers, or customers with the technical information and independent analysis that is required for their assessment of the SUN2000 series string inverters.

This report is not intended to replicate or substitute for other third party audits or assessments which we expect to be undertaken by manufacturers, namely:

- QHSE management system audits and certification to ISO 9001, ISO 14001 and OHSAS 18001, covering the production and assembly lines, sub-suppliers and design, manufacture, assembly, delivery, operation and maintenance activities.
- Type or component certification for the specific component or other established certification standards, covering design and production.



2 Company Overview

2.1 Company Background

Established and headquartered in Shenzhen, Huawei Technologies Co., Ltd was founded in 1987 by Ren Zhengfei, an ex-military officer, as a privately owned company. Huawei is a leading global Information Communications Technology solutions provider and the world's largest telecommunication equipment manufacturer. It overtook Ericsson in 2012 and currently has over 176,000 employees globally. Huawei exports its products and provides solutions to over 170 countries and regions. While not a listed company, Huawei has achieved annual sales revenue of USD 46.5 billion in 2014 with an increase of 17.7% over the previous year and ranked 228 of Fortune Global 500 the same year. In 2015, Huawei's sales revenue is estimated at CNY 390 billion (approximately USD 60 billion). Huawei's Annual Report is published every year by KPMG and is available to clients upon request.

Huawei employs over 79,000 product and solution research and development (R&D) staff worldwide, comprising 45% of the company's total workforce. 72% of the employees working overseas are local recruits. It has set up 16 R&D centres and 31 joint innovation centres in countries including China, the United States, Canada, Germany, Ireland, Sweden, Turkey, India, Russia and Japan, and has invested around USD 9.18 billion on R&D in 2015. As a result of continuous growth in R&D investment, Huawei had filed 52,550 patent applications in China and 30,613 outside of China, with 50,377 granted as of 31 December 2015.

Huawei has three distinct business groups:

- Enterprise: provides technology solutions for governments, public bodies, finance, energy and electrical power and transportation.
- Carrier: provides wireless access, fixed access, energy, transport networks and telecoms software.
- Consumer: provides products and services mainly focused on mobile phones, mobile broadband and home devices.

Huawei also offers Network Energy, an integrated system that involves integrated power electronics, digital information, network communication, data centre energy, and smart PV plants. The network aims to ease operation and maintenance, and maximise plant value.

Huawei was previously active in the power control business with a subsidiary, Avansys Power until this was sold to Emerson in 2002. A five year embargo prevented Huawei from developing inverter technology further after this acquisition. After which Huawei re-entered the inverter development market for telecoms and renewable energy.



2.2 Huawei Inverter Global Team and Huawei Smart PV Solution

Huawei started development of the solar inverter business in 2009 and its solar inverter products, FusionSolar, belong to the Enterprise business group. The inverter team within Huawei currently has over 800 employees in R&D, with approximately 10% from foreign countries, and has more than 100 patents related to inverters. There are six R&D facilities under the Huawei Inverter Global Team:

- Nuremberg, Germany – Architecture design centre
- Stockholm, Sweden – Algorithm & topology research centre
- Shanghai, China – Product design centre
- Shenzhen, China – Product engineering & manufacturing
- Beijing, China – FusionSolar¹ Smart PV Management System R&D
- Chengdu, China – FusionSolar Smart PV Management System R&D

Since its formation in 2010, Huawei Inverter Global has grown rapidly. In 2014, it achieved a total shipment of 4 GW and sales orders of 5.5 GW, ranking number eight in the global market from IHS' 2015 Q1 report. However, in 2015 orders are expected to reach 12 GW, with shipment totalling 10 GW. The inverters manufacturing and assembly site is based in the Songshan Lake factory in Dongguang, with a manufacturing capability of approximately 80,000 units per month, which is equivalent to approximately 2.8 GW.

In 2015, there has been an increase of order and shipment of Huawei Smart PV Plant Solution, as shown in Figure 2-1.

¹ FusionSolar: Huawei's intelligent PV solutions that integrates PV with the digital information technology.



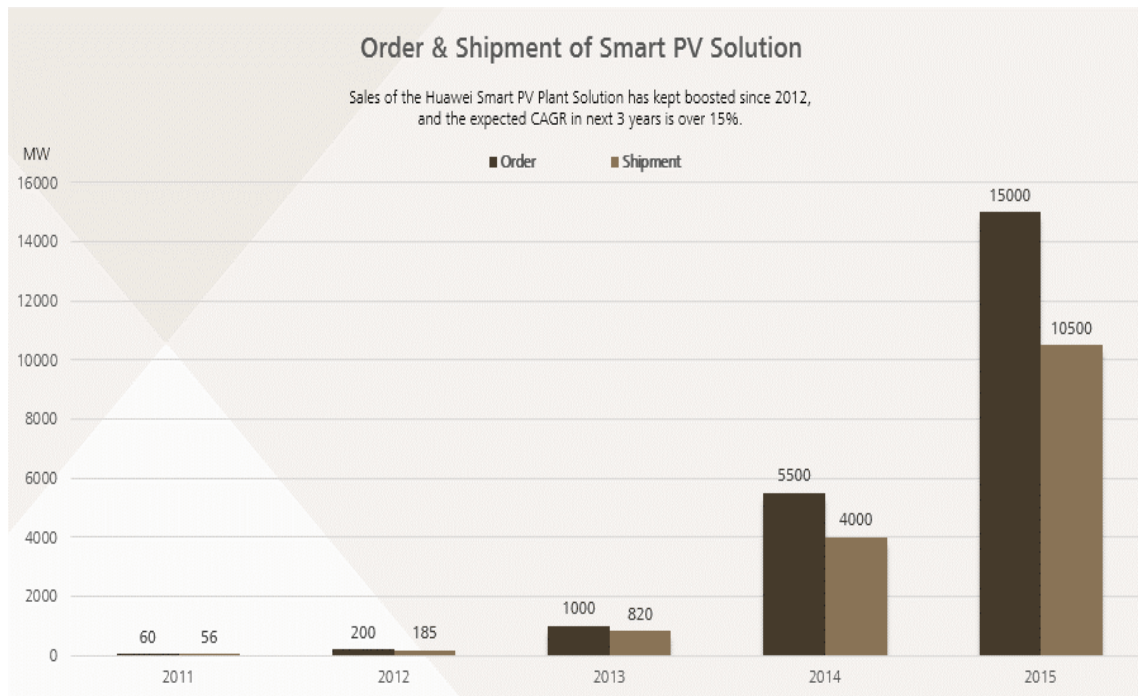

Figure 2-1: Smart PV Plant Solution Growth

2.3 Experience and Track Record

This review will focus on the SUN2000 series string inverter offered by Huawei.

Huawei has accumulated extensive manufacturing experience in the telecoms industry over 20 years. More recently, Huawei has developed solar inverter manufacturing capabilities based on the same DC to AC technology platform. Huawei first started developing the concept of inverter manufacturing in 2009 and started a production line in 2012 so is relatively new to the solar inverter manufacturing industry.

However, it should be considered that Huawei has been an established telecoms power supplier since 2001, with applicable technologies and manufacturing processes with inverter devices.

At the end of 2015, Huawei had shipped over 10 GW of solar inverters in a number of countries, mainly deployed on large-scale solar PV installations. Table 2-1 provides a track record of installations using Huawei's inverters, with the most successful orders from the SUN2000 string inverters. Table 2-2 summarises the global shipment levels on a regional basis.

Table 2-1: Huawei Inverter Track Record

Project Location	Project Developer	Capacity (MW)	Inverter Model
Yanchi, Ningxai	China Minsheng Investment New Energy	2000	SUN2000-40KTL



Project Location	Project Developer	Capacity (MW)	Inverter Model
Ningdong, Ningxia	Baofeng Energy	700	SUN2000-50KTL
Gonghe, Qinghai	State Power Investment Corporation	108	SUN2000-50KTL
Golmud, Qinghai	State Power Investment Corporation	130	SUN2000-28KTL
Tongxin, Ningxia	China Minsheng Investment New Energy	100	SUN2000-40KTL
Zhangbei, Hebei	SFCE	200	SUN2000-40KTL
Luoshitan, Ningxia	TALESUN	100	SUN2000-28KTL
Huzhou, Zhejiang	TALESUN	100	SUN2000-40KTL
Gonghe, Qinghai	TALESUN	100	SUN2000-40KTL
Hami, Xinjiang	TALESUN	100	SUN2000-40KTL
Togtoh, Inner Mongolia	Shanlu Energy Group	100	SUN2000-40KTL
Alashan Meng, Inner Mongolia	Green Giant Energy	100	SUN2000-28KTL
Yangzhou, Jiangsu	Shunda New Energy	108	SUN2000-28KTL
Drayton Manor, UK	Anesco	45	SUN2000-33KTL
Cowdown, UK	Solarcentury	40	SUN2000-33KTL
Rose & Crow Solar Farm, UK	Baywa r.e.	30	SUN2000-33KTL
Mount Solar Farm, UK	Baywa r.e.	23	SUN2000-33KTL
Cockhill Solar Farm, UK	Greencells	20	SUN2000-20KTL
Roundponds Solar Farm, UK	Greencells	13	SUN2000-20KTL
Hawkers Solar Farm, UK	Greencells	12	SUN2000-28KTL
Vouzance, France	Green Energy 3000	12	SUN2000-28KTL
Osternienburg, Germany	Green Energy 3000	10	SUN2000-28KTL
Krempendorf, Germany	Parabel Solar	10	SUN2000-28KTL
Schwerin, Germany	PV Strom	10	SUN2000-33KTL



Project Location	Project Developer	Capacity (MW)	Inverter Model
Hungary, Germany	Asianet	10	SUN2000-23KTL
Schwarzheide, Germany	Bejulo	10	SUN2000-33KTL
Erzurum Turkey	Halken Enerji	9	SUN2000-33KTL
Horam Solar Farm, UK	ibvogt	8	SUN2000-28KTL
Varen , France	Amarenco	8	SUN2000-28KTL
Llwyndu Solar Farm, UK	European Energy	8	SUN2000-20KTL
Corum, Turkey	Nurol Teknoloji	6	SUN2000-33KTL
Meuselwitz, Germany	Pfalzsolar	6	SUN2000-33KTL
Salhouse Solar Farm, UK	Wirsol	5	SUN2000-23KTL
Gretton Solar Farm, UK	CTF	5	SUN2000-28KTL
Willow Solar Farm, UK	British Gas	5	SUN2000-28KTL
Gurramkonda, India	Waaneep Solar Private Ltd	50	SUN2000-40KTL
Fukushima, Japan	DAIWA HOUSE INDUSTRY CO., LTD.	60	SUN2000-28KTL
Sendai, Japan	POWER MAX Co.,Ltd.	50	SUN2000-28KTL
Philippines	ET Solar	40	SUN2000-30KTL-A
Bangkok, Thailand	BSP	30	SUN2000-28KTL
Oita Prefecture, Japan	POWER MAX Co.,Ltd.	23	SUN2000-28KTL
Malaysia	MSR	15	SUN2000-33KTL
Philippines	Benny	13	SUN2000-33KTL
Nagoya, Japan	DAIWA HOUSE INDUSTRY CO., LTD.	14	SUN2000-28KTL
Monte Plate, Dominican Republic	Soventix	33	SUN2000-30KTL-A



Table 2-2: Huawei Smart PV Solution Shipment in 2015

Region	Countries	Shipment (MW)
Asia	China	8,500
	Japan & Korea	500
	Thailand, Philippines & Malaysia	300
	India	100
Europe	EU region	800
North America	USA, Canada & Mexico	200
South America	Chile & Brazil	100

In addition to their global shipment portfolio, Huawei has a well-established technical support infrastructure. Huawei employs a three tiered technical support infrastructure, where offices and support centres appear to be widespread across the world and have an extensive global coverage. The infrastructure comprises of the following three tiers:

- Tier 1: Local technical assistance centre, helpdesks and local spare part centres. More than 134 country spare parts logistic centres.
- Tier 2: Three global technical assistance centres in China, Romania, and Mexico and nine global spare part operation centres in China, Romania, Russia, Malaysia, India, Egypt, Brazil, Mexico and America. These centres operate in their native languages.
- Tier 3: HQ expert team and central spare parts centre.

Compared to more established providers such as SMA and ABB-PowerOne, Huawei has a relatively recent track record of inverter manufacture and supply. Despite their extensive global coverage in technical support, the inverters may experience challenges when operating in new environments and require adjustment to these conditions. One of the key benefits of string inverters over central inverters is that if performance issues are evident, individual units can easily be swapped out rather than requiring trained technicians to perform a repair in-situ.



2.4 Summary

Huawei is a major global manufacturer of telecommunications equipment and has recently entered the inverter manufacturing market, becoming one of the largest global players in the industry in a rapid period of time. Huawei has extensive in-house technical expertise for further research and development of inverters and recent growth has positioned Huawei as one of the world's largest inverter manufacturers. Whilst the track record of installations is limited to primarily large numbers of installed capacity in 2014 and 2015, the TA has conducted a review of reliability testing to demonstrate durability. This is detailed further in Section 7.

3 Technical Characteristics

3.1 Product & Solution Portfolio

Huawei manufactures a range of products designed for solar photovoltaic solutions. These include the SUN2000 string inverter series, the iManager smart management system incorporating the Smart Logger, iManager NetEco 1000S and FusionSolar.

The SUN2000 range of string inverters, which are the subject of this report, have been specially developed to be used in photovoltaic systems. They have been designed to operate at high efficiency levels by using highly efficient components throughout the product.

In addition to being able to communicate with the industry standard RS485 standard, Huawei inverters can communicate with PLC, a communication solution developed by Huawei. With this communication method, data is transferred via the AC output power cables, meaning no additional communication cable is required. Data transfer is also done at a higher speed to conventional RS485.

The SUN2000 range of string inverters, as illustrated in Figure 3-1, Figure 3-2 are the primary brand of solar plant string inverters manufactured by Huawei, encompassing units rated from 8 kW to 42 kW.





Figure 3-1: SUN2000-8KTL String Inverter



Figure 3-2: SUN2000-33KTL String Inverter





Figure 3-3: SUN2000-36/42KTL String Inverter

3.2 Technical Specifications

The technical specifications for the SUN2000 range of string inverters are listed in Table 3-1.



Table 3-1: SUN2000 Series Inverter Technical Specifications

Model	8kTL	12kTL	17kTL	20kTL	23kTL	28kTL	30kTL-A	33kTL	36kTL	40kTL	42kTL
	Efficiency										
Max Efficiency	98.5%	98.5%	98.6%	98.6%	98.6%	98.7%	98.6%	98.6%	98.8%	98.8%	98.8%
Euro Efficiency	98.0%	98.0%	98.3%	98.3%	98.3%	98.4%	98.3%	98.3%	98.6%	98.4%	98.6%
	Inputs										
Max DC Input (W)	9,100	13,700	19,100	22,500	23,600	28,200	30,800	33,800	40,800	40,800	47,900
Max Voltage	1,000 V								1,100 V	1,000 V	1,100 V
MPP Voltage Range (V)	320 – 800	380 – 800	400 – 800	480 – 800	480 – 800	480 – 800	560 – 850	480 – 800	480 – 850	580 – 850	580 – 850
Max Current per MPPT (A)	18							23	22	23	22
Max Inputs	4	4	6	6	6	6	6	6	8	6	8
MPP Trackers	2	2	3	3	3	3	3	3	4	3	4
	Outputs										
Rated Power (W)	8,000	12,000	17,000	20,000	23,000	27,500	30,000	30,000	36,000	36,000	42,000
Max Power (VA)	8,800	13,200	18,700	22,000	23,000	27,500	33,000	33,000	40,000	40,000	47,000



Model	8kTL	12kTL	17kTL	20kTL	23kTL	28kTL	30kTL-A	33kTL	36kTL	40kTL	42kTL
Max Current (A)	12.8	19.2	28.4	32	35	33	40	50	48.2 ²	48	56.6
Power Factor	0.8 Leading / 0.8 Lagging										
AC Grid Frequency (Hz)	50 / 60										
	General Data										
Operating Temperature Range	-25°C to +60°C (-13°F to +140°F)										
Relative Humidity	0 ~ 100%										
Weight (kg)	40	40	48	48	48	48	50	50	55	50	55

² 48.2 A at 480 V, 57.8 A at 400 V, 60.8 A at 380 V.



3.2.1 Overview

Huawei is relatively new to the solar inverter market but has over 20 years' experience in the manufacturing of electronic components. Their main focus is on power supplies and controls systems which are the basis for the SUN2000 string inverter series.

The ethos of the SUN2000 string inverter series design is to minimise maintenance with high reliability and efficiency. The SUN2000 is a transformer-less grid-tied photovoltaic inverter which converts high voltage DC power into sine wave 3-phase grid-frequency AC. The absence of a transformer leads to higher efficiency, reductions in weight and size and a lower cost due to the reduced number of components.

The component parts of the SUN2000 series inverter system are located in a single aluminium cabinet with integral heat sink. The cabinet is IP65 rated for outdoor use which means the electronic components are protected against dust and water ingress which reduces the likelihood of damage to components. This is in line with industry standards.

The majority of PV systems installed globally would have an expected DC/AC power ratio (installed PV module DC power / inverter AC power) of between 1.10 and 1.35. This is in order to operate within the higher efficiency range of the inverters and because the peak DC output of the PV array is rarely achieved under typical meteorological conditions. As long as the system design is within the inverters' input voltage and current limitations (open circuit voltage and short circuit current respectively), the inverters will regulate the power accordingly.

The TA has also received confirmation from Huawei that there will be no impact on their warranty conditions or inverter failure rate with any DC/AC ratios, provided the inverters' open circuit voltage and the short circuit current are respected and the design is approved by Huawei. As an example, Huawei has provided the TA with array designs using a DC/AC ratio of 1.27 for the 36kTL model.

The MPP voltage range of the inverters is wide meaning multiple system configurations are possible. Furthermore the separation between the maximum MPP voltage and maximum input voltage is wide enough for crystalline silicon module PV array systems. The power factor range of 0.8 leading to 0.8 lagging provides suitable control for typical grid connection requirements. Also total harmonic distortion is less than 3% which is considered acceptable.

Figure 3-4 below shows the electrical diagram and arrangement of the SUN2000 series of inverters. This illustrates the MPPT capability and fault monitoring for up to 6 strings.

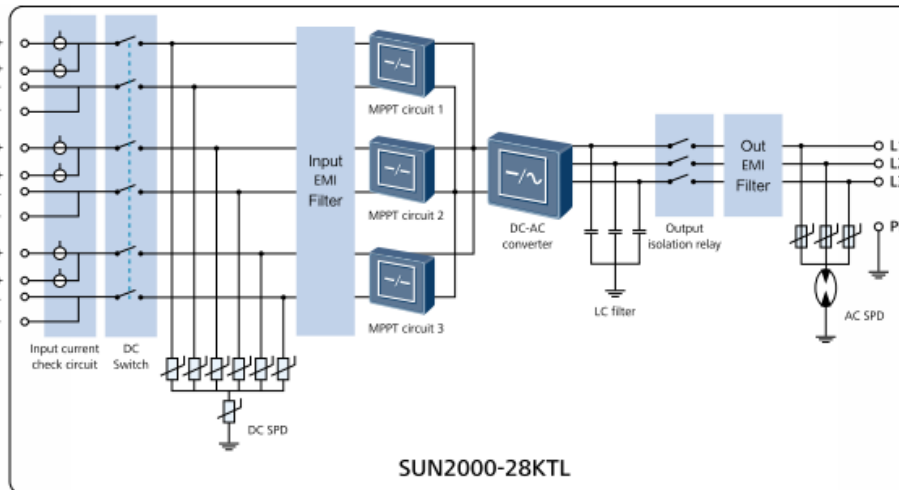
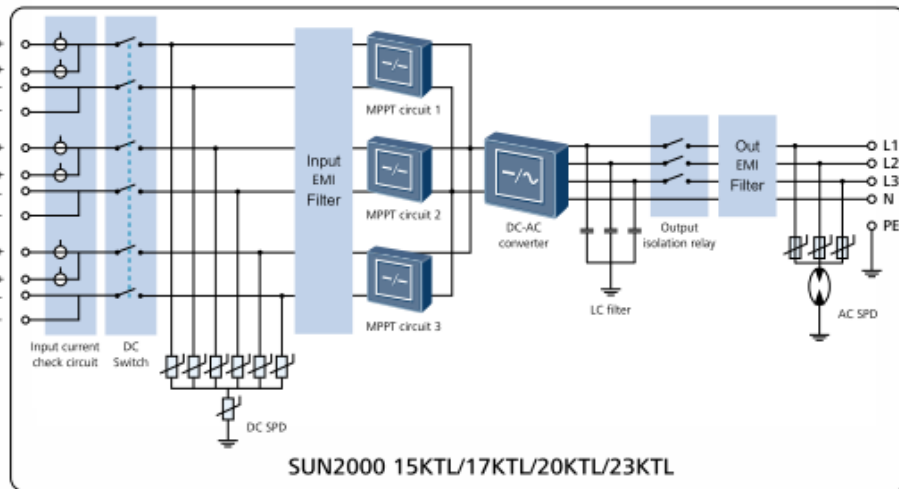
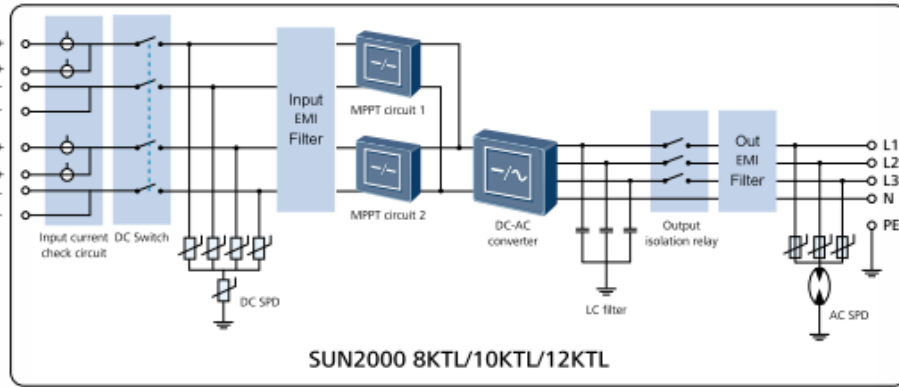

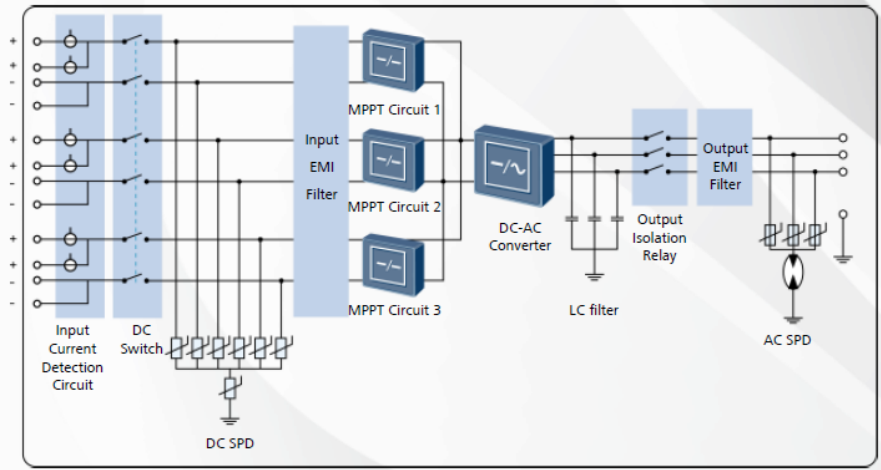

SUN2000-30KTL-A

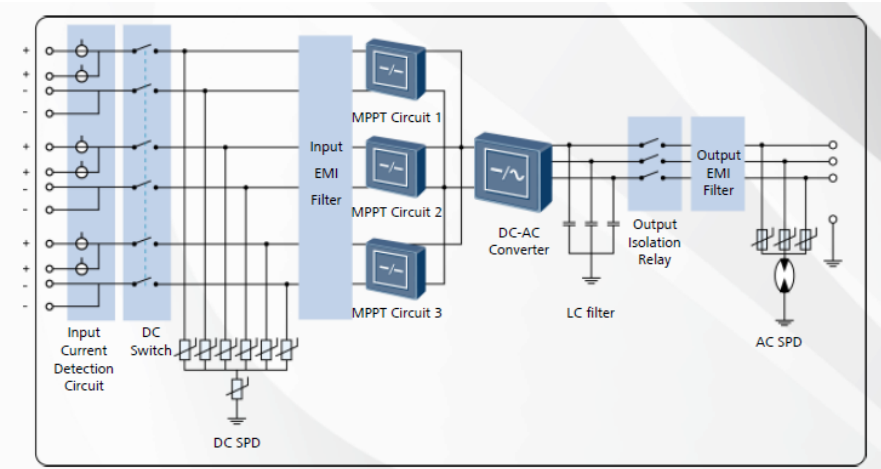

SUN2000-33KTL

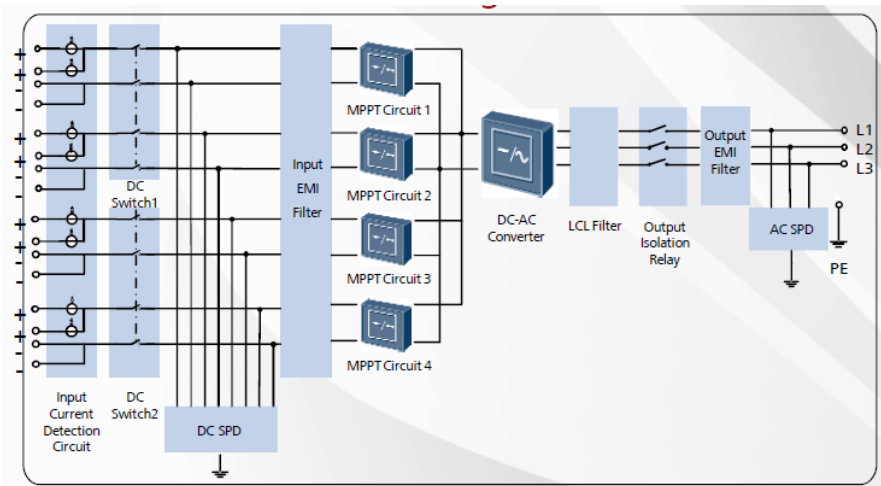

SUN2000-36KTL

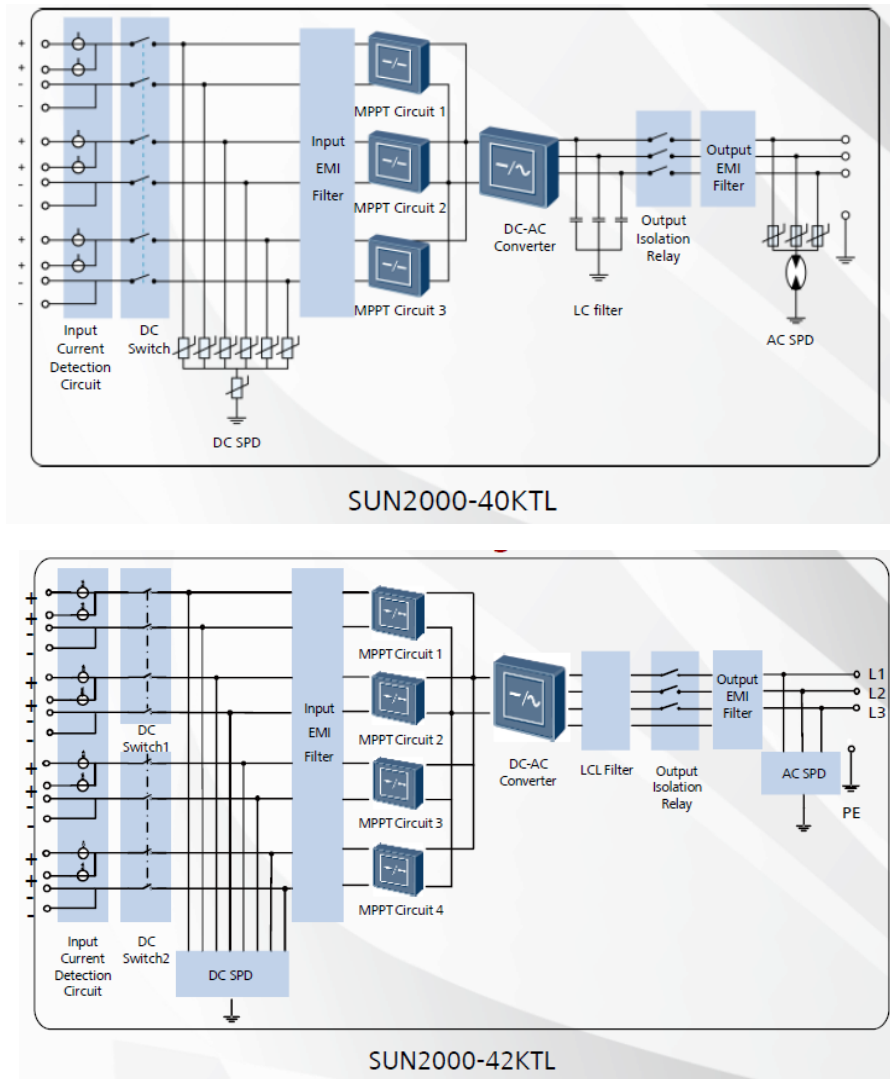

Figure 3-4: SUN2000 circuit diagram

The following protection devices are included within the inverter design:

- Input-side disconnection device.
- Anti-islanding protection.
- AC over current protection.
- DC reverse-polarity protection.
- Type II DC surge arresters.
- Type II AC surge arresters.
- Insulation measurement.
- Residual current monitoring.

The TA considers the inverters to have suitable protection devices in place on both the DC and AC side to protect the PV system and inverter components.

Further parameters include an operational altitude of up to 3,000 m and noise emission of 29 dB for all models with a rated capacity up to 28kTL. Higher rated models from 30kTL, can operate up to 4,000 m at 33 dB. Both parameters are considered above average when compared to similar inverters. Ventilation is natural with warm air guided through a cooling element on the rear of the housing. The absence of a cooling fan reduces noise levels, maintenance requirements, auxiliary power consumption and increases reliability. According to information provided by the Client, auxiliary power consumption is approximately 20 W during operation and 1 W at night, which is acceptable.

3.2.2 Inverter circuit layout

The SUN2000 inverter series is a compact 40-55 kg single aluminium cased unit. It comes with an integral heat sink and attachable wall mount. For models 8KTL – 28KTL, there is a door mounted LCD graphics capable display with additional monitoring LED's as shown in Figure 3-1. For models 33KTL and above, monitoring LED indicators are present at the front of the inverter, as shown in Figure 3-2. DC voltage, DC Current, AC Voltage, AC power, yield and temperature can be accessed and displayed in either daily or monthly values. Faults are logged in the alert section of the display. This gives a high spatial resolution of the PV system and inverter performance, allowing rapid determination of faulty areas.

Figure 3-5 illustrates the internal view of the inverter, with the output from the PV array reaching the power stage via an electromagnetic interference (EMI) filter, the voltage of which is then adjusted by three symmetrical boost converters with soft switching technology.



Figure 3-5: SUN2000 Internal Circuits

Soft switching technology allows switching losses to be minimised as switching only occurs if the voltage or current equals zero. The output then flows into a Huawei designed output bridge. The output bridge is a three point half bridge with one arm from the midpoint of the capacitor half bridge of the intermediate voltage circuit.

The output voltage circuit features two anti-parallel transistor diodes that are connected in series. The transistors and diodes of the power stage are designed as six integrated modules. The output voltage blocks are subsequently smoothed into the grid frequency by chokes.

The inverter is protected by an automatic disconnect which separates the inverter from the grid if a measured grid voltage or frequency deviation is detected. The internal controls of the inverter calculate if the MPP tracker will work independently or if all strings will be stacked in parallel. The MPPT design allows the voltage range to be defined depending on operational conditions.

3.2.2.1 Summary and conclusions

The TA considers the design of the inverter to provide a safe and efficient means of converting DC power to AC. The inclusion of two or three model dependant MPPTs increases the efficiency of the inverter in multiple operational environments such as shading, different string output powers, different modules and varied tilt angles.

3.2.3 Inverter Components

The manufacture of inverters requires use of sub-components and therefore the selection, supply and control of these parts plays an important role in the overall design and assembly process. In this section, the TA assesses the major sub-components utilised in the inverter construction.

Huawei implements a supply chain incorporating five supply centres, one in China and four in other territories. The main components for the SUN2000 inverter series are sourced from China, USA and Hungary through established supply chains.

A list of major sub-components within the inverter is presented in Table 3-2. The TA has assessed key components which have the greatest effect on inverter performance, these being Insulated Gate Bipolar Transistors (IGBTs) and capacitors.

Table 3-2: Sub-Supplier Assessment

Product	Manufacturer	Location	ISO Compliance
IGBT	Vincotech	Germany	ISO/TS16949:2009 ISO 14001

Product	Manufacturer	Location	ISO Compliance
Output Filter Capacitor	EPCOS AG	Hungary	ISO 9001 ISO 14001 ISO TS 16949
Output Filter Inductor	Huawei	China	ISO 9000
Current Sensor	LEM	China	ISO 9001 ISO 14001 ISO TS 16949
Digital Signal Processor	Texas Instruments Inc.	USA	ISO 9001 ISO 16949 ISO 14001
DC Port Terminal	Amphenol East Asia Electronic Technology (Shenzhen)	China	ISO 9001 ISO TS 16949
AC Port Terminal	Amphenol East Asia Electronic Technology (Shenzhen)	China	ISO 9001 ISO TS 16949
Grid Connection Relay	Tyco Electronic Co., Ltd	USA	ISO 9001 ISO 14001 ISO TS 16949
Leakage Current Sensor	Vacuumschmelze GmbH	USA	ISO 9001 ISO 14001
Lightning Protection Module	Shenzhen Haipengxin Electronics	China	ISO 9001 ISO 14001

3.2.3.1 IGBT's

The IGBT (Insulated Gate Bipolar Transistor) is a semiconductor based device that provides the high frequency switching within the IGBT bridge.

IGBT utilises homogenous silicon which is widely used in inverter design and is extensively understood. It has a mixed voltage component topology, neutral point clamped inverter, reactive power capability and a low inductance layout.

The IGBTs are produced in ISO 16949 quality assurance and ISO 14001 environmental management certified manufacturing facilities. ISO 16949 is based on ISO 9001 and uses a similar process-orientated approach to quality control. It has been developed for the automotive industry but can be utilised in other manufacturing processes such as inverter manufacture. Therefore the IGBTs are manufactured in well-controlled facilities, increasing the likelihood of good quality components.

3.2.3.2 Capacitors

The output filter capacitors used are of electrolytic and foil capacitors. The main causes of failure in capacitors used in photovoltaic inverters are overheating, excessive voltages or ripple currents. The electrolytic capacitors in the power elements and control electronics have a temperature rating of up to 105°C and are well suited for outdoor temperatures expected during normal operation. Independent testing of the inverter by Photon has shown that at ambient temperatures of 25°C, operating temperatures of the capacitors are within the non-critical range, as shown in Figure 3-6. As illustrated, the temperature increases around the capacitor area but does not exceed 100°C.

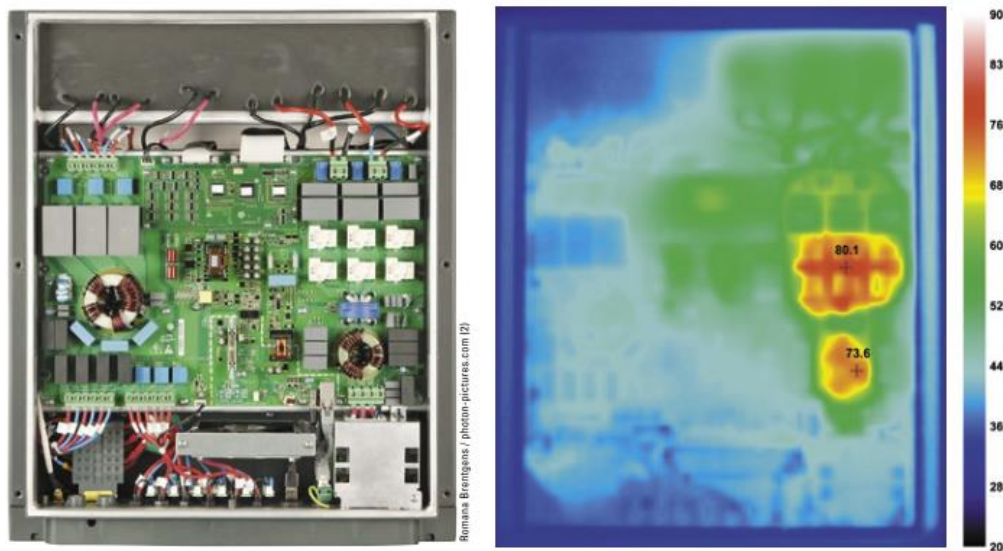

Figure 3-6: Thermal image of operation

EPCOS are certified to ISO 9001 quality assurance and ISO 14001 environmental management standards increasing the likelihood of good quality components being manufactured.

3.2.3.3 Summary

The TA considers that the policy of using quality assured manufacturers for key components produces acceptable product quality. A large number of components are manufactured in China with the remainder manufactured by established manufacturers with strong supply chains. This gives confidence that supply chain issues will be minimised. A review of key components was undertaken and the TA believes that the components within the inverter are of good quality and suitable for use within this inverter.

3.3 Performance

Besides cost, perhaps the most crucial parameter when selecting an inverter is the efficiency. In this section the TA analyses the key efficiency parameters along with the MPPT characteristics.

3.3.1 Efficiency

Huawei claim a maximum efficiency across the range from 98.5% to 98.7% as shown previously in Table 3-1 and Figure 3-7. This has been measured according to IEC 61683 standards specified within an inverter technical specification standard prepared by China General Certification (CGC). This efficiency range is at the upper end of comparable products. Independent testing by Photon confirmed the efficiency profile of the inverter according to the manufacturer's claims.

Figure 3-7 illustrates the efficiency curve for the 28kTL inverter at three voltage levels within the MPP voltage range. The optimal inverter efficiency is towards the mid-range dropping by 0.6% at low voltages. It is recommended PV systems are designed with a suitable stringing arrangement to operate within the maximum inverter efficiency range.

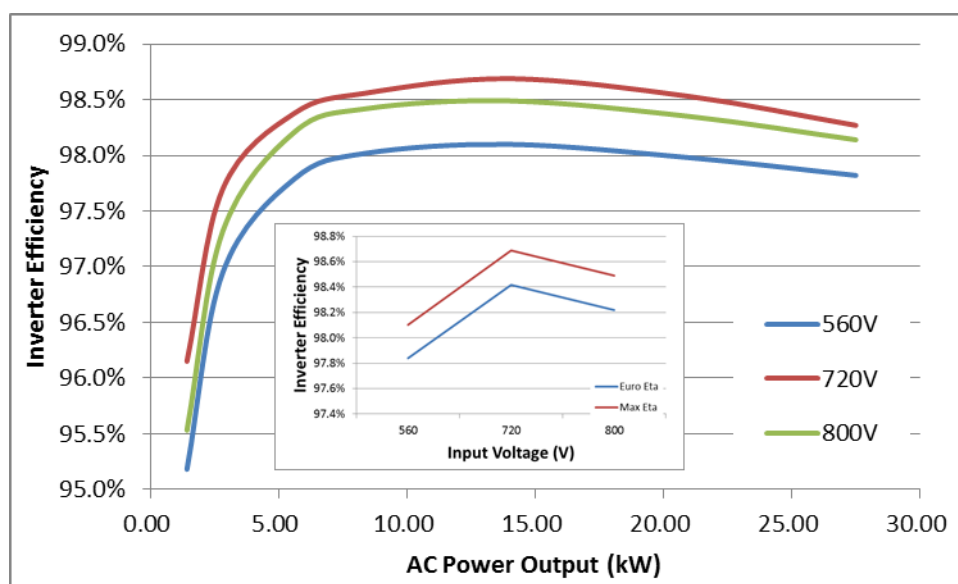

Figure 3-7: Huawei 28kTL efficiency curve

Figure 3-8 illustrates the efficiency curve as measured by Photon for the 20kTL inverter in a symmetrical configuration (DC power is distributed symmetrically to the MPP trackers). As can be seen the efficiency does not vary significantly at different conditions due to a high MPP adjustment efficiency.

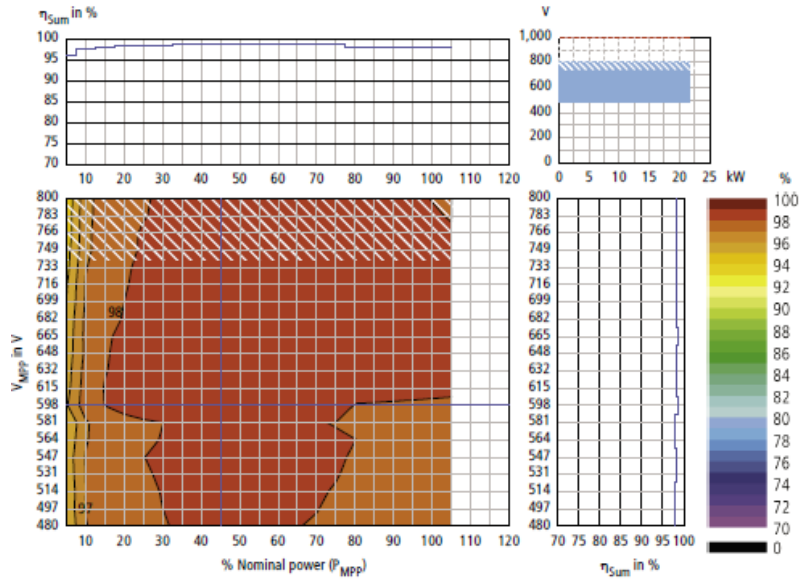

Figure 3-8: Photon 20kTL efficiency curve (Symmetrical)

It is noted overload testing was completed during testing completed by Photon up to a nominal power ratio of 1.30 with an inverter output of 108.8% of the nominal rating. The TA was provided with test results for the inverter overloading power output capacity as illustrated in Figure 3-9.

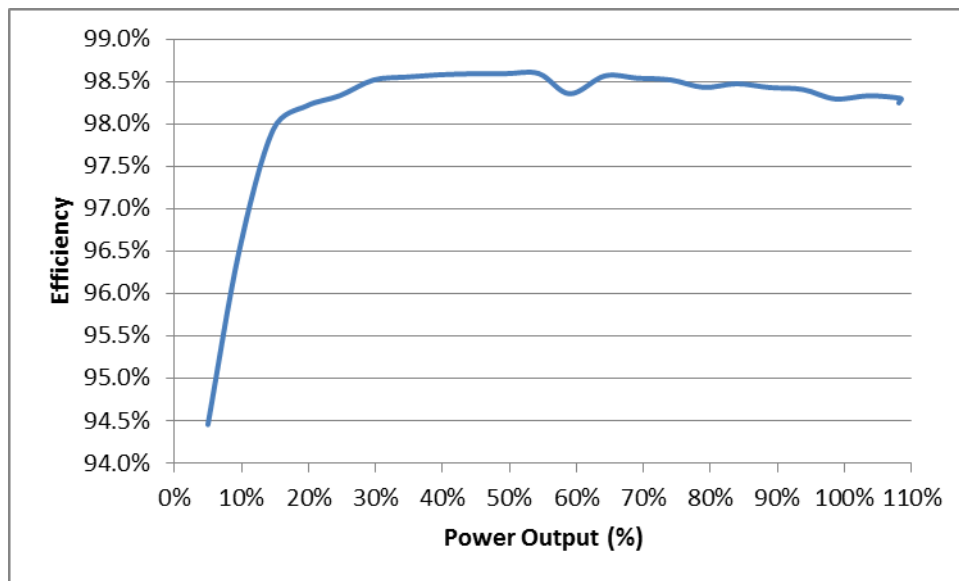

Figure 3-9: Inverter Efficiency up to overloaded conditions

Figure 3-9 demonstrates that the inverter efficiency is relatively stable across the power output range with a maximum output capacity of 108% of the nominal rated capacity. This is beneficial as the inverter can effectively produce up to 8% greater output than the nominal rating.

3.3.2 MPPT

The Huawei SUN2000 series has a maximum of three maximum power point trackers (MPPT) for increased versatility when connected to different module types, outputs, quantities or arrangements. MPP tracking is utilised to maximise the power from a PV array by ensuring the string provides the maximum power. The tracking algorithms operate by continuously monitoring the voltage and adjusting the load impedance to establish the most efficient operating voltage for each input.

The TA opines that the MPPT concept is acceptable and in line with industry practice. The datasheet does not indicate the MPPT efficiency, however the Photon test results indicate it is high.

3.3.3 Summary of performance

The TA considers the published performance figures as at the upper range of current industry performance. These have been confirmed by independent testing by industry experts 'Photon' who rated the SUN2000 20kTL as A+. This is one of only four inverters to have received this award.

4 Compliance to International Grid Standards

Inverters are required to be compliant with various grid codes and standards in order to be utilised on installations in different countries. Grid standards are written by regulators or network operators to ensure grid power quality is achieved by all generators before energy is fed into the electrical network. The TA has summarised the standards for key global solar markets, including for the UK, USA, Germany, China, India, South Africa, Jordan, Republic of Ireland and Chile. These are compared against the certificates of conformity held by the inverter family and summarised in Table 4-1.

Table 4-1: Grid Standards

Country	Certifying Body	Grid Standard	8kTL	12kTL	17kTL	20kTL	23kTL	28kTL	30kTL-A	33kTL	40kTL
UK	Bureau Veritas	G59/2		C	C	C					
	Bureau Veritas	G59/3		C	C	C	C	C			C
	Bureau Veritas	G83/2	C								C
	Bureau Veritas TUV-SUD	IEC 61727 Photovoltaic (PV) systems – Characteristics of the utility interface (50 Hz)	C	C	C	C	C	C	C	C	
	Bureau Veritas TUV-SUD	IEC 62116 Utility-interconnected photovoltaic inverters – Test procedure of islanding prevention measures (50 Hz)	C	C	C	C	C	C	C	C	
	Bureau Veritas	IEC 61000-6-1, IEC 61000-6-2, IEC 61000-6-3, IEC 61000-6-4	C	C	C	C	C	C	C	C	C



Country	Certifying Body	Grid Standard	8kTL	12kTL	17kTL	20kTL	23kTL	28kTL	30kTL-A	33kTL	40kTL
	Huawei	IEC 61000-3-2, IEC 61000-3-3, IEC 61000-3-11, IEC 61000-3-12									
Germany	Bureau Veritas TUV-SUD	VDE-AR-N 4105	C	C	C	C	C			C	C
	Bureau Veritas Photon TUV-SUD	VDE 0126-1-1	C	C	C	C	C	C		C	C
	Bureau Veritas GL	BDEW:2008 (1/2013) DIN EN 61400-21 FGW TR3, FGW TR4. FGW TR8	C	C	C	C	C	C		C	C
	Bureau Veritas TUV-SUD	IEC 61727 Photovoltaic (PV) systems – Characteristics of the utility interface (50 Hz)	C	C	C	C	C	C	C	C	
	Bureau Veritas TUV-SUD	IEC 62116 Utility-interconnected photovoltaic inverters – Test procedure of islanding prevention measures (50 Hz)	C	C	C	C	C	C	C	C	
	Bureau Veritas Huawei	IEC 61000-6-1, IEC 61000-6-2, IEC 61000-6-3, IEC 61000-6-4 IEC 61000-3-2, IEC 61000-3-3, IEC 61000-3-11, IEC 61000-3-12	C	C	C	C	C	C	C	C	C



Country	Certifying Body	Grid Standard	8kTL	12kTL	17kTL	20kTL	23kTL	28kTL	30kTL-A	33kTL	40kTL
The US	Not specified	IEEE 1547							C		
	TUV-RL TUV-SUD	IEC 61727 Photovoltaic (PV) systems – Characteristics of the utility interface (60 Hz)	C	C	C	C	C	C	C	C	C
	TUV-RL TUV-SUD	IEC 62116 Utility-interconnected photovoltaic inverters – Test procedure of islanding prevention measures (60 Hz)	C	C	C	C	C	C	C	C	C
China	Not specified	NB/T 32004 GB/T 19964-2012 “Technical requirements for connecting photovoltaic power station to power system”	C	C	C	C				C	C
	Bureau Veritas TUV-SUD	IEC 61727 Photovoltaic (PV) systems – Characteristics of the utility interface (50 Hz)	C	C	C	C	C	C	C	C	
	Bureau Veritas TUV-SUD	IEC 62116 Utility-interconnected photovoltaic inverters – Test procedure of islanding prevention measures (50 Hz)	C	C	C	C	C	C	C	C	
	Bureau Veritas Huawei	IEC 61000-6-1, IEC 61000-6-2, IEC 61000-6-3, IEC 61000-6-4 IEC 61000-3-2, IEC 61000-3-3, IEC 61000-3-11, IEC 61000-3-12	C	C	C	C	C	C	C	C	C
India	TUV-RL	IEC 61683	C	C					X	C	C



Country	Certifying Body	Grid Standard	8kTL	12kTL	17kTL	20kTL	23kTL	28kTL	30kTL-A	33kTL	40kTL
		IEC 60068-2-1, IEC 60068-2-2, IEC 60068-2-14, IEC 60068-2-30									
	Bureau Veritas TUV-SUD	IEC 61727 Photovoltaic (PV) systems – Characteristics of the utility interface (50 Hz)	C	C	C	C	C	C	C	C	
	Bureau Veritas TUV-SUD	IEC 62116 Utility-interconnected photovoltaic inverters – Test procedure of islanding prevention measures (50 Hz)	C	C	C	C	C	C	C	C	
	Bureau Veritas Huawei	IEC 61000-6-1, IEC 61000-6-2, IEC 61000-6-3, IEC 61000-6-4 IEC 61000-3-2, IEC 61000-3-3, IEC 61000-3-11, IEC 61000-3-12	C	C	C	C	C	C	C	C	C
Jordan	Bureau Veritas TUV-SUD	G59/3 DIN V VDE 0126-1-1		C	C	C	C	C		C	C
	Bureau Veritas TUV-SUD	IEC 61727 Photovoltaic (PV) systems – Characteristics of the utility interface (50 Hz)	C	C	C	C	C	C	C	C	
	Bureau Veritas TUV-SUD	IEC 62116 Utility-interconnected photovoltaic inverters – Test procedure of islanding prevention measures (50 Hz)	C	C	C	C	C	C	C	C	
	Bureau Veritas Huawei	IEC 61000-6-1, IEC 61000-6-2, IEC 61000-6-3, IEC 61000-6-4 IEC 61000-3-2, IEC 61000-3-3, IEC 61000-3-11, IEC 61000-3-12	C	C	C	C	C	C	C	C	C



Country	Certifying Body	Grid Standard	8kTL	12kTL	17kTL	20kTL	23kTL	28kTL	30kTL-A	33kTL	40kTL
South Africa	Bureau Veritas	NRS 097-2-1 DIN V VDE 0126-1-1	C	C	C	C	C	C	X	C	
	Bureau Veritas TUV-SUD	IEC 61727 Photovoltaic (PV) systems – Characteristics of the utility interface (50 Hz)	C	C	C	C	C	C	C	C	
	Bureau Veritas TUV-SUD	IEC 62116 Utility-interconnected photovoltaic inverters – Test procedure of islanding prevention measures (50 Hz)	C	C	C	C	C	C	C	C	
	Bureau Veritas Huawei	IEC 61000-6-1, IEC 61000-6-2, IEC 61000-6-3, IEC 61000-6-4 IEC 61000-3-2, IEC 61000-3-3, IEC 61000-3-11, IEC 61000-3-12	C	C	C	C	C	C	C	C	C
Republic of Ireland	Bureau Veritas	EN 50438 Requirements for micro-generating plants to be connected in parallel with public low-voltage distribution networks DIN V VDE 0126-1-1	C	C	C	C	C	C		C	
	Bureau Veritas TUV-SUD	IEC 61727 Photovoltaic (PV) systems – Characteristics of the utility interface (50 Hz)	C	C	C	C	C	C	C	C	
	Bureau Veritas TUV-SUD	IEC 62116 Utility-interconnected photovoltaic inverters – Test procedure of islanding prevention measures (50 Hz)	C	C	C	C	C	C	C	C	



Country	Certifying Body	Grid Standard	8kTL	12kTL	17kTL	20kTL	23kTL	28kTL	30kTL-A	33kTL	40kTL
	Bureau Veritas Huawei	IEC 61000-6-1, IEC 61000-6-2, IEC 61000-6-3, IEC 61000-6-4 IEC 61000-3-2, IEC 61000-3-3, IEC 61000-3-11, IEC 61000-3-12	C	C	C	C	C	C	C	C	C
Chile	Bureau Veritas TUV-SUD	IEC 61727 Photovoltaic (PV) systems – Characteristics of the utility interface (50 Hz)	C	C	C	C	C	C	C	C	
	Bureau Veritas TUV-SUD	IEC 62116 Utility-interconnected photovoltaic inverters – Test procedure of islanding prevention measures (50 Hz)	C	C	C	C	C	C	C	C	
	Bureau Veritas Huawei	IEC 61000-6-1, IEC 61000-6-2, IEC 61000-6-3, IEC 61000-6-4 IEC 61000-3-2, IEC 61000-3-3, IEC 61000-3-11, IEC 61000-3-12	C	C	C	C	C	C	C	C	C
Notes: C: Inverter certified to conform to grid codes (or equivalent standards). X: Inverter certification to conform to grid codes (or equivalent standards) underway.											



With the exception of the 40kTL model, all other Huawei inverter models hold common global certificates to IEC 61727: “Photovoltaic systems – Characteristics of the utility interface (at 50 Hz and 60 Hz)”, IEC 62116: “Utility-interconnected photovoltaic inverters – Test procedure of islanding prevention measures (50Hz)”, and an ensemble of electromagnetic compatibility (EMC) certificates. This would enable the inverters to meet the minimum general grid requirements for most countries. Whilst not having evidence for certifications for some of the aforementioned standards, the 40kTL model has already been certified to meet grid codes for the UK, Germany, China, India and Jordan.

The 30kTL-A model appears to be certified only for use in the US grid at 60 Hz, with certifications for use in the Indian and South African grid underway.

Despite not being certified to Chile’s grid code, most of the inverters reviewed are capable of operating within Chile’s grid requirements. However, the TA recommends that the inverters be certified to meet Chile’s grid requirements so that they can be introduced to the nascent PV market in Chile. The same recommendation applies to all relevant models under Huawei’s inverter development plan.

5 Quality, Environmental, Health and Safety Procedures

The management of Quality, Health, Safety and Environmental (QHSE) risks is an important factor in good company governance. Proper QHSE management helps maintain good work practices, reduces the risk of claims and reputation loss.

This section presents the review of the current QHSE management processes within Huawei’s facility in Shenzhen.

5.1 Certification

Huawei is certified to the internationally recognised standard for management systems demonstrating that they conform to the latest quality standards. Table 5-1 gives the certification obtained by Huawei including the auditor and expiry dates.

Table 5-1: EHS Certification

Certificate	Description	Auditor	Valid Date	Expiry Date
ISO 9001:2008	Quality management systems	Hong Kong Quality Assurance Agency	13/05/2011	12/05/2017



Certificate	Description	Auditor	Valid Date	Expiry Date
ISO 14001:2004	Environmental management systems	Bureau Veritas	01/06/2015	31/05/2018
OHSAS 18001:2007	Occupational Health and Safety	Bureau Veritas	01/06/2015	31/05/2018

The TA is satisfied that Huawei has a good level of certification for management systems control, in line with leading inverter manufacturers.

5.2 QHSE Management

This section explains further the control steps in place for manufacturing of the inverters.

5.2.1 Quality Management

Quality assurance (QA) procedures are a requirement for any industry standard certification and Huawei has extensive experience in the manufacturing sector therefore has built up a wide range of QA procedures.

Huawei has a supply chain quality management committee established to ensure sub-supplier components are suitable for use in the inverter. There are two main departments in charge of this aspect:

- Quality & Operation Management (QOM) Department.
- Manufacturing Quality Management (MQM) Department.

The QOM department controls the daily quality management of the supply chain. The MQM department controls quality management of the manufacturing process with sub-departments including:

- Quality audit.
- Quality assurance.
- Material quality.
- Process quality.
- Quality inspection.
- Electronic Manufacturing Services (EMS) quality.

The manufacturing quality management hierarchy is given in Figure 5-1. Regular internal audits are conducted by different departments along with external auditing.



Manufacturing Quality Management -Quality Organization

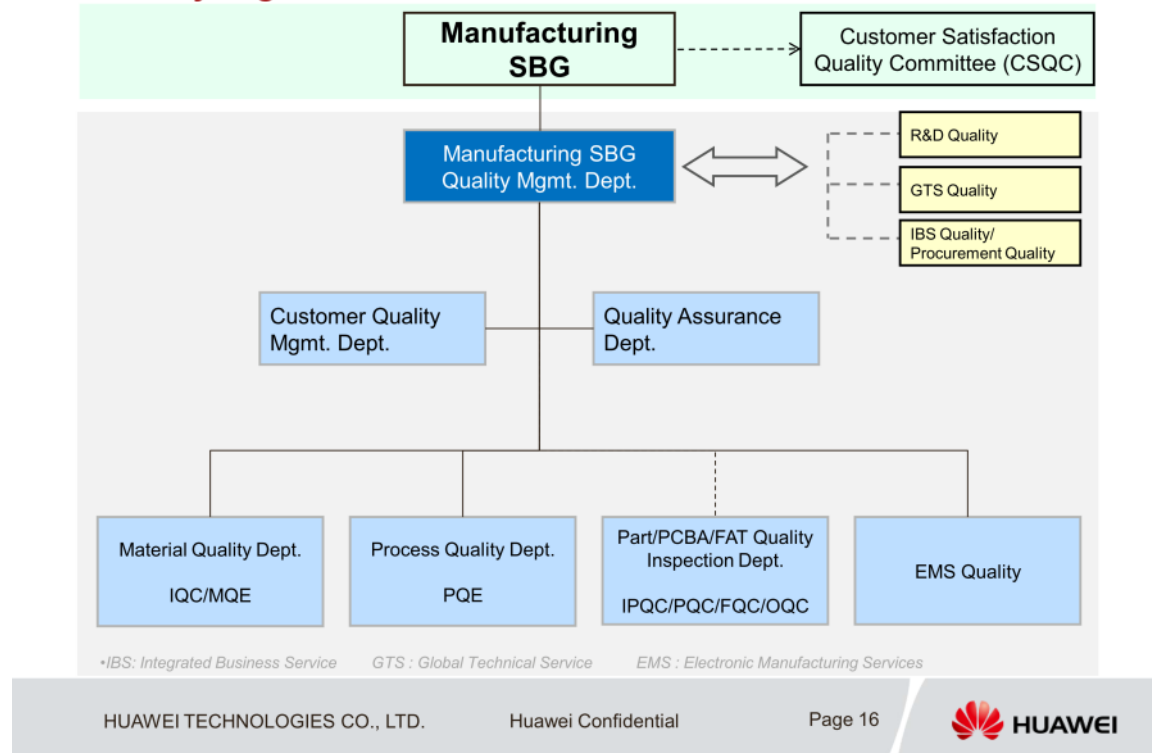

Figure 5-1: Quality Management Hierarchy

An end-to-end quality appraisal system is in place as verified by the TA's factory inspection with regular inspections during the manufacturing process. Material and product reliability tests are conducted on both raw materials and manufactured products to ensure quality. All these data are fed into a quality information system which allows product traceability management and determine and solution of quality issues. The TA considers the overall quality assurance procedures to be well-defined and documented, allowing regular and close inspection of the entire manufacturing process.

5.2.2 Environmental Management

Huawei is certified to ISO 14001 for environmental management which is the industry standard. The TA noted during the site visit compliance was maintained with national codes for waste and environmental processes.

Environmental management is verified by Guangdong Environmental Inspection Bureau, an independent third party. Periodical inspections are undertaken along with hazardous material analysis within the working facilities. This indicates a well-managed working environment.



5.2.3 Health and Safety Management

Huawei has obtained the internationally recognised OHSAS 18001 certification and has a number of policies in place covering staff health and safety. There is a certified functional group undertaking daily management of the factory. It is in charge of all safety matters including reporting of defects to the board and conducting risk assessments.

Huawei provides the following health and safety provisions to their workforce:

- Staff are given regular health and safety training throughout their employment including a comprehensive induction on commencement of employment based on the positions taken.
- Huawei comply with mandatory occupational rules of law, for example overtime working hours control, health insurance and insurance for occupational accidents.
- Staff are given annual medical examinations by the local hospital.

It was noted during the TA's factory inspection that the site is maintained in a clean condition, which is an indication of good housekeeping and attitudes to safety. Furthermore Huawei has various employee care initiatives in place, including periodically holding teambuilding, handcrafting competition and self-evaluation before daily work.

5.3 Certification

Huawei SUN2000 inverter manufacturing has been accredited according to QEHS (ISO series) as detailed in Table 5-1. The TA has compiled technical certification for the inverters in Table 5-2.



Table 5-2: Certification Obtained by Huawei for SUN2000 Inverters

Certification	Definition	Examiner	Date Certified
IEC/EN62109-1: 2010	Safety of power converters for use in PV power systems: General requirements	Huawei	16 April 2012
		TUV Rheinland	14 January 2014
IEC/EN 62109-2: 2011	Safety of power converters for use in PV power systems: Particular requirements for inverters	Huawei	16 April 2012
		TUV Rheinland	14 January 2014
EN 61000-6-1: 2007	Electromagnetic Compatibility (EMC): Generic standards – Immunity for residential, commercial and light-industrial environments	Huawei	16 April 2012
		TUV Rheinland	4 December 2013
EN 61000-6-2: 2005	EMC: Generic standards – Immunity for industrial environments	Huawei	16 April 2012
		TUV Rheinland	4 December 2013
EN 61000-6-3: 2007+A1	EMC: Generic standards – Emission standard for residential, commercial and light-industrial environments	Huawei	16 April 2012
		TUV Rheinland	4 December 2013
EN 61000-6-4: 2007+A1	EMC: Generic standards – Emission standard for industrial environments	Huawei	16 April 2012
		TUV Rheinland	4 December 2013



Certification	Definition	Examiner	Date Certified
EN 50581: 2012	Restriction of Hazardous Substances (RoHS): Technical documentation for the assessment of electrical and electronic products with respect to the restriction of hazardous substances	Huawei	16 April 2012
EC NO. 1907/2006	REGULATION concerning the Registration, Evaluation, Authorization and Restriction of Chemicals (REACH): DEHP contents 0.23%	Huawei	16 April 2012
2002/96/EC, 2012/19/EU	Waste Electrical and Electronic Equipment (WEEE)	Huawei	16 April 2012
CE	EMC Directive, 2004/108/EC	Bureau Veritas	10 December 2012
CE	Low Voltage Directive, 2006/95/EC	Bureau Veritas	28 December 2012
2006/95/EC	Low Voltage Directive	TUV Rheinland	14 January 2014
G83/2:2012	Recommendations for the Connection of Type Tested Small-scale Embedded Generators in Parallel with Low-Voltage Distribution Systems	Bureau Veritas	4 June 2013
G59/3:2012	Recommendation for the Connection of Generating Plant to the Distribution Systems of licensed Distribution Network Operators	Bureau Veritas	11 March 2014



Table 5-2 gives the current certification status of the SUN2000 inverters. Huawei has acquired CE, EMC directive, low voltage directive, REACH, WEEE and RoHS certifications from independent testing bodies including TUV Rheinland and Bureau Veritas. The certificate date shows all these third-party tests were recently carried out.

The SUN2000 series inverters are compliant with the following standards:

- EMC Immunity EN 61000-6-1, 2
- EMC Emission EN 61000-6-3, 4

By meeting the requirements of EN 61000 standards, the inverters comply with the European EMC directive 2004/108/EC. Certified by TUV Rheinland, the inverters also comply with the European low voltage directive 2006/95/EC.

Compliance with the EMC and Low Voltage directive allows the product to apply for 'CE' marking which is a mandatory requirement in all European Economic Area countries.

In addition the following standards are applied to the SUN2000 inverter:

- REACH – DEHP content EC NO. 1907/2006
- Power converter safety IEC 62109-1, 2
- Hazardous substances EN 50581

The Huawei SUN2000 inverters have obtained the G83/2 and G59/3 certification which is a required standard for generators in the UK.

Industry standards specifically for inverter long-term reliability and testing are not well-defined. Therefore the TA has compared the certification status of the SUN2000 inverters with industry leading inverter manufacturers below:

- EN 60909: EMC– short-circuit currents in 3 phase AC systems.
- EN 60068-2-68: Dust and sand blowing test.
- EN 61701, EN 60068-2-52: Salt mist resistance and corrosion test .
- DIN EN ISO 3744:04/2005: Sound power levels of noise sources test.
- EN 60068-2-30, 78: Vibration tests.
- EN 60068-2-29, 64: Salt mist resistance and corrosion test.
- EN 60529: Protection for person, sealed against dust, protection against water and rain and sprinkler tests.
- BDEW, FGW TR3.
- IEEE 1547: Islanding tests.

The TA has reviewed in-house reliability and environmental tests completed on Huawei inverters in Section 7.1.1.



5.3.1 Summary

The TA considers Huawei to have an appropriate level of certification required for the installation of inverters in numerous countries. Huawei has well-established quality, environmental, health and safety management processes in place based on an extensive history in manufacturing electronic components. Huawei has industry standard certification including ISO 9001, ISO 14001 and OHSAS 18001. The TA observed EHS procedures were adhered to during a factory inspection.

6 Manufacturing Processes

Huawei's global supply chain includes five key supply centres – one domestic supply centre (China) and four overseas (Hungary, Dubai, Mexico and Brazil). The centre in China also undertakes new product pilot testing and the core product manufacturing processes including raw materials, semi-finished product production, cabinet assembly, testing and delivery. The other supply centres potentially have the capability to manufacture inverters, although all are currently manufactured in the facility in China.

The manufacturing process for producing the Huawei SUN2000 inverters is explained in detail within this section.

Huawei's core manufacturing centre is in operation at the Songshan Lake facility, which is located in Dongguan city within 50 km of Shenzhen Port and Guangzhou Port. The Songshan Lake facility has 24,000 employees for the production of all Huawei products within the confine of 1.4 km². For the manufacturing of string inverters, two Original Equipment Manufacturers (OEMs), namely Foxconn and I-Brights are authorised by Huawei for providing Electronic Manufacturing Services (EMS) in 2014 and 2015 respectively. Details of these facilities are provided in Table 6-1.

Table 6-1: Manufacturing Facility Details

Factory	Location	ISO Compliance	Production Commence	Annual Capacity (Set)
Huawei Songshan Lake	Songshan Lake, Dongguan, Guangdong, China	ISO 9001:2008, ISO 14001:2004 OHSAS18001:2007	2013	96,000
I-Brights Dongguan (OEM)	Tangxia, Dongguan, Guangdong, China	ISO 9001:2008, ISO 14001:2004 OHSAS18001:2007	2014	216,000



Factory	Location	ISO Compliance	Production Commence	Annual Capacity (Set)
Foxconn Shenzhen (OEM)	Baoan, Shenzhen, Guangdong, China	ISO 9001:2008, ISO 14001:2004 OHSAS18001:2007	2015	240,000

Representatives of SgurrEnergy conducted an inspection of Huawei's manufacturing facility located in Shenzhen, China on 15 May 2014 and 6 January 2016 respectively. The inspection included a review of:

- Long-term environmental testing of components and inverters.
- Research and Development laboratory.
- Inverter production line.
- Meeting with after-sales personnel.
- Meeting with manufacturing process engineers.

It is noted the TA was unable to take photographic images of the manufacturing process due to Huawei's confidentiality requirements. Images are provided from documentation provided by the Client.

The core string inverter manufacturing process includes pre-assembly, Printed Circuit Board (PCB) and unit assembly, testing and packing with further details provided in the following sub-sections.

A computerised Manufacturing Execution System (MES) with appliance of the Internet of Things (IOT) technology is applied across the manufacturing process, covering in-production tracking and warehouse management. The MES system adds assurance that all quality procedures are suitably controlled and traceable.

6.1 Pre-Assembly Stage

Incoming components for the inverter are selected from a defined list of suppliers given in Table 3-2. There is a well-defined process for approval of new suppliers, assessing both quality and capabilities. The Engineering Change Management process involves key personnel from multiple departments including in-house testing to verify suitability of new components and systems. Materials are inspected for packaging and labelling, appearance, validity period, environmental performance and other requirements before being approved for storage. Electrical components are also tests with spot checks on resistance, capacitance, high voltage insulation and inductance. Components are barcode scanned for document and process control for each inverter so that analysis can be undertaken post-completion if required.



The Automated Logistics Centre (ALS) which includes the warehouse management system (WMS) and the Storage and Retrieval System (ARS) is in operation as shown in Figure 6-1, with the appliance of Internet of Things (IOT) technology to ensure traceability and efficiency of production.



Figure 6-1: Automatic Logistics Centre

Lead times of components range between 30 days for DC port terminals to 120 days for digital signal processors. Monthly component reviews are conducted to assess ongoing quality and supply issues. Furthermore there are a significant number of in-house tests completed on both components and the inverter to ensure quality and durability.

Environmental conditions within the factory are between 20°C to 30°C with a humidity level between 45% and 75% which can be considered acceptable. Overall the pre-assembly stage is well documented with suitable testing and control processes implemented.

6.2 Inverter Assembly Process

The inverter assembly process involves a staged approach with Printed Circuit Board Assembly (PCBA) followed by overall inverter assembly.

6.2.1 PCBA Process

Figure 6-2 shows the manufacturing process of making Printed Circuit Boards Assembly (PCBA) in Huawei's factory.



Figure 6-2: PCB Process



A Surface Mount Technology (SMT) production line is dedicated to inverter production which is able to make 44,000 PCB's per day, approximately 30% of the total capacity, including the production of the other two OEMs. The PCB is assembled using Siemen's high-speed placement system and multi-functional SMT machine. In-line testing of the PCB includes serial peripheral interface online testing, AOI/5DX combination testing, in-circuit test (ICT) and functional testing. Figure 6-3 shows the SMT manufacturing line inside the Songshan Lake factory.



Figure 6-3: SMT Production in Songshan Lake Factory

6.2.2 Unit Assembly Process



Regular quality inspections are conducted by personnel along the production process as observed by the TA. The overall production time including testing is approximately two days for PCBA production and 1.15 days for inverter assembly in 2014. The main bottleneck in overall production is sourcing of externally provided components.

Staff operating machinery appeared capable and well-trained in operations. Machinery was well-arranged, tidy and separated along the production line. Table 6-2 illustrates the inverter assembly process.

Table 6-2: Photos of Unit Assembly Process

Assembly Process	Photograph
Potting	



Assembly Process	Photograph
Assembly line	
Comprehensive Functional Test station	
Aging testing and packing	

6.3 Final Testing and Packing

All inverters are visually inspected for quality issues upon completion. They are then tested for electrical parameters which are documented using the barcode scanning system. The TA observed testing results in spreadsheet format stored within Huawei's internal management system after completion. All inverters are subject to a 6 hour functional test at full load with an IGBT temperature of 50°C to ensure build quality is appropriate. Figure 6-4 shows the testing process of inverters upon completion, which can be considered satisfactory.



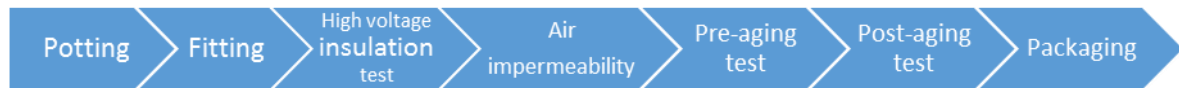

Figure 6-4: Unit Assembly Process

Finished goods are stored at a separate storage facility with 5,000 inverters typically in stock at any one time at Huawei's facility. The majority of manufactured inverters are the larger 33kTL type due to the greatest popularity, with the remainder consisting of smaller size inverters within the range. Shipping times depend on transport type, with approximately 6 weeks by sea and 2 weeks by plane to Europe for urgent requests.

6.4 Production Capacity

In the selection of an inverter manufacturer, it is important to check that the manufacturer has sufficient production capacity to manufacture and deliver the equipment to site on time, with minimum delay. Inverters are a significant part of any solar PV project and so it is important to minimise lead times for their manufacture and delivery. The lead time of Huawei inverters is displayed in Figure 6-5. The total lead time from purchase order to final delivery of Huawei inverters is 9 weeks, which the TA considers to be in line with the industry standard. Huawei also has supply centres and hubs in China, Netherlands, Hungary, UAE, Brazil, and Mexico, which ensures shorter lead time for delivery across the globe. The warehouse in Rotterdam enables European customers to receive their products within 15 working days upon submitting a purchase order.



Figure 6-5: Huawei Inverter Lead Time

The production facility at Huawei Songshan Lake Campus operates 24 hours a day, seven days per week. Current manufacturing capacity is approximately 8,000 inverters per month and a further 38,000 per month contributed from two other OEM plants. Huawei has the manufacturing capability for 46,000 inverters per month as of end of 2015.



6.5 Summary

The TA considers the manufacturing process of the SUN2000 series inverters to be well-designed with appropriate quality management processes ensuring each stage are conducted to a high standard. Staff on the production line appears capable and finished inverters were good quality.

7 Performance and Reliability

Inverter reliability is an important concept when assessing the quality of the equipment as inverters typically have the highest rate of failure out of the major installed equipment on a PV plant. In terms of reliability of the SUN2000 series products, the TA has reviewed the certification status, testing, operational performance and warranty conditions of the inverters. Each of the reliability aspects is further described in the following sub-sections.

7.1 Testing

7.1.1 In-house Testing

Every SUN2000 series inverter manufactured at the Songshan Lake factory goes through the Huawei QA (Quality Assurance) and testing process. Throughout Huawei's E2E (End-to-End) quality control, a number of checks and tests are conducted for ensuring good quality during the manufacturing process. A barcode system enables Huawei to track, monitor and handle information associated with each product. The quality control flow and system are briefly described below.

- Incoming materials:
 - Check with specification to meet Acceptance Quality Level (AQL).
- Printing:
 - Parameters control.
 - Statistical Process Control.
- Mounting:
 - Parameters control.
 - Appearance check.
- Reflow:
 - Parameters control.
 - Appearance check.
 - Automatic X-ray Inspection.
 - Automatic Optical Inspection.
- Through Hole Technology:
 - Appearance check.
- Wave soldering:
 - Parameters control.
 - Appearance check.



- PBCA testing:
 - In Circuit Test.
 - Function Test.
- Assembling and aging.
- Packing and shipment.

An example of a grid-connected PV inverter delivery inspection report and packing list was provided to the TA. The following tests are detailed on this documentation for the SUN2000 33-40KTL inverters:

- Device label and structure inspection.
- Hi-pot test.
- Maximum efficiency.
- Total Harmonic Distortion Current (THDi) test.
- Over Voltage Protection (OVP) & Ultra-Voltage Protection (UVP) test.
- Anti-Islanding protection test.
- Grid recovering test.
- Communication test.
- Automatic start-up/shutdown.
- Insulation resistance test.
- Continuous aging test.
- Restoring factory settings.

Each test is described with key findings and PASS/FAIL results. The delivery inspection list, with device serial number, is enclosed within the product packaging. The TA considers the tests to be in line with industry standard.

In particular, within an Ongoing Reliability Test (ORT) plan in Table 7-1 gives the specific reliability tests undertaken at the factory.

Table 7-1: In-house Reliability Testing

Test Items	Objective
Highly Accelerated Life Test	To find out the weak points of the inverter system.
Short term light radiation	To test the influence of temperature and light radiation.
High temperature rain test	To test the tightness and anti-condensation level of the system.
High Temperature Operating Life	To test the system adaptability under high temperature.



Test Items	Objective
Field exposure test	To test the system adaptability under high salt and high pollution condition.
Long term light radiation aging	To test the system adaptability under long-term radiation condition.
Temperature cycling test	To test the system consistency under high and low temperature to find out failure mode at early stage.
Temperature Humidity Bias test	Is designed to accelerate carrion and dendritic growth in order to test the system adaptability under high temperature and high humidity.
Ageing	To analyse the early ageing mode.
Length of Lifetime Test	To test the system reliability for long term operation.

The testing procedures given in Table 7-1 show that the inverters are put through a thorough testing regime. Such in-house testing capabilities are possible because Huawei manufactures numerous electronic devices with similar requirements.

The environmental tolerance requirements of inverters can be different around the world, with specific conditions, including:

- Hot and dry desert e.g. Middle East and parts of North America.
- Hot and humid e.g. South East Asia and South America.
- Temperate and cool e.g. Europe.

Beyond these overall regional characteristics, the local atmospheric conditions can also be a challenge for inverters, such as salt mist or dust environments. The TA inspected the in-house testing facilities and noted testing of inverters under high-temperature conditions. Furthermore, salt mist corrosion testing facilities were also evident, which can be an issue for coastal-based sites.

The TA received test records for a number of the tests described in Table 7-1 including:

- Functional test record of 6 inverters during manufacturing.
- Long-term temperature cycling testing.
- Hainan field exposure test.
- High temperature rain test.
- Temperature Humidity Bias (THB) test.
- Network Energy Product Ageing Instruction.



Every 1-2 weeks, two inverters will be chosen for temperature recycling tests to assure manufacturing reliability, with the remainder of the tests conducted during the research and development period. Each inverter is tested after production for the following parameters, with specific pass/fail criteria:

- Query Test (UUT version).
- Query Test (UUT Off Alarm).
- Query Test (B1 Status).
- E-Label Load.
- Out Open without Grid.
- Query Test (UUT On Alarm).
- Calibration Test (Adjust Vin).
- Calibration Test (Adjust Vout).
- Calibration Test (Adjust Iout).
- Calibration Test (Adjust Pout).
- Query Test (Power Status).
- ISO Test.
- Efficiency Test.
- Output Total Harmonic Distortion (THDi) With Grid.
- Residual Current Device (RCD) Test.
- Query Test (UUT Temperature).
- Protect for Island.
- Protect for Input Over Voltage.
- Automatic On_Off.
- History Clearance.

The TA considers the above parameter testing regime to appropriately cover the main functions of each inverter for operation. Furthermore, efficiency tests are conducted at half power load and full power load at input voltages of 600 V and 800 V. Test results provided for 6 inverters from the manufacturing line indicated no failures for the test parameters.

A long-term temperature cycling test was conducted on a 33 kVA inverter, with a temperature range between -40°C to 70°C for 1,500 cycles with temperature increments at 60 minutes and a change rate of 10°C per minute. Additionally, a SUN2000 series inverter was tested in the seaside 350M Hainan field test centre under a natural high humidity, high salt mist and relatively high temperature environment for one year with a DC loading of 4.5 kW/535 V. No significant issues were illustrated in both test reports. Two 40 kVA inverters were tested for Temperature Humidity Bias (THB) with duration of 2,000 hours at temperatures of 70°C, relative humidity (RH) of 80% and 1% of rated loading with no issues identified.



The TA is generally satisfied with the test results. According to public press releases, other tests including a shipping vibration test, shock test and humidity freeze test are also considered by Huawei. However, the TA was not provided with related test reports.

Huawei also runs performance tests, environment tests, EMC (Electrical Magnetic Compatibility) testing and safety testing in house to control product quality through all aspects. The TA considers Huawei has a robust quality assurance process and products manufactured strictly under this procedure are well guaranteed to maintain good performance as accredited to the technical certifications and through product serving lifetime.

7.1.2 Independent Testing

Huawei had the SUN2000-20kTL inverter tested in June 2013 by an independent third party body – Photon International.³ The test mainly focused on efficiency testing and the overall results give the Huawei SUN2000-20kTL inverters an A+ efficiency level at medium and high irradiation. This inverter test result ranked No.3 among all inverter manufacturers Photon has tested, with the table of results given in Appendix A: The only inverters above the SUN2000 series are provided by SMA and Refusol and use silicon carbide transistors which are more efficient although less proven.

Photon reported the inverter is a high quality device and notably thermographic testing of the temperature of the film capacitors remains in the non-critical range indicating the device has no hot spot problems. Table 7-2 gives the efficiency testing results independently measured by Photon laboratory. The inverter achieves a maximum efficiency of 98.1% at high irradiation levels and 98.0% under medium irradiation conditions. The SUN2000-kTL inverters can therefore be considered one of the current industry leading string inverters.

Table 7-2: Photon Efficiency Test Results

Maximum Efficiency	MPPT Adjustment Efficiency
Case 1: DC power is distributed symmetrically to the MPP trackers and is given as the sum of DC nominal power.	
98.6%	99.8%
Case 2: DC power distribution is divided asymmetrically among the number of tracker inputs.	

³ Photon International, June 2013, "Watch out SMA".



Maximum Efficiency	MPPT Adjustment Efficiency
98.3%	>99.0%
Case 3: three trackers are connected in parallel, therefore the inverter functions almost as a one-tracker device.	
98.6%	>99.0%

7.2 Operational and Long-term Performance

7.2.1 Operational Review

The TA was provided with access to a monitoring system comparing string inverters from five leading suppliers within the industry including a single Huawei 20kTL inverter. The PV system is located in Germany and data are available from February 2014 through to June 2014.

A direct system performance comparison is not possible due to the different AC capacities of the devices and hence different nominal power ratios. However, the Huawei inverter power output profile appears relatively smooth with a response time comparable with the other inverters. The inverter start-up is also comparable considering 15-minute resolution data intervals. Peak output of the inverter is not limited during sunny days due to the 1:1 nominal power ratio of the system compared to the maximum inverter output.

The inverter temperature profile is at the lower range compared to other manufacturers, which is beneficial and highlights the effectiveness of the natural cooling mechanism of the device. A total of approximately 2 years of data were available, with no significant downtime of the inverter within this period and comparable performance with other inverters.

The Performance Ratio (PR) of a solar PV plant is an important figure indicating the percentage of actual energy output out of theoretical possible energy output. The TA was provided with the unverified average and maximum performance ratio of 14 solar PV plants and these values are given Table 7-3.

Table 7-3: Performance Ratio of 14 solar PV plants

Plant Location	Period	Avg PR (%)	Max PR (%)	Model No.
UK	Apr – Sep 2015	89.65	96.47	SUN2000-28KTL
UK	Jul 2015	85.39	86.40	SUN2000-28KTL



Plant Location	Period	Avg PR (%)	Max PR (%)	Model No.
UK	Jun – Oct 2015	87.48	93.32	SUN2000-20KTL
UK	Jun 2015	85.08	87.44	SUN2000-20KTL
UK	Jul 2015	86.30	86.80	SUN2000-20KTL
UK	Jul 2015	88.21	88.47	SUN2000-20KTL
Germany	Jan – Nov 2015	87.49	93.01	SUN2000-28KTL
Germany	Jan – Nov 2015	90.43	96.86	SUN2000-20KTL
Germany	Feb – Dec 2014	89.13	94.88	SUN2000-20KTL
	Jan – Jun 2015	92.50	94.91	
Germany	Jan – Jul 2015	86.91	91.51	SUN2000-20KTL
Germany	Jan – Nov 2015	91.13	101.05	SUN2000-20KTL
Germany	Feb – Nov 2015	86.90	97.39	SUN2000-20KTL
Denmark	Jul 2015	85.30	86.13	SUN2000-20KTL
Germany – 3 rd Party Monitoring	Jul 2015	85.55	90.95	-

Although the inverter is not the only factor defining the PR of a solar plant, it is considered as one of the key contributors of losses. Therefore, the results in the above table illustrate proven performance of the Huawei string inverters for operational PV plants.



7.2.2 Inverter Failure

The failure analysis for SUN2000 V1 and V2 series are shown in Figure 7-1 and Figure 7-2. It can be observed that failures attributable to manufacturing constitutes a low proportion among the various factors, suggesting strong build quality. On the other hand, the major factors for these inverter failures are attributed to hardware failure and installation. It is advisable for Huawei to have more stringent incoming component quality checks prior to manufacturing and to have greater support/training for inverter installation as remedial actions to these issues. It appears that Huawei is thorough in their root cause analysis, which is considered to be good practice for quality improvement.

Failure Analysis of SUN2000 V1 Series

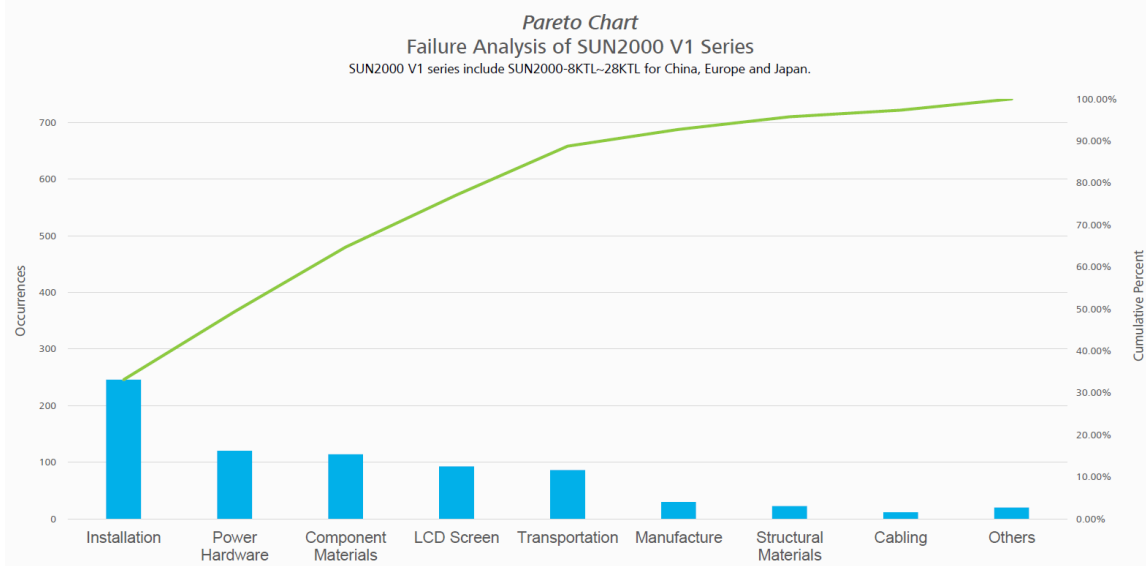

Figure 7-1: Failure Analysis of SUN2000 V1 Series



Failure Analysis of SUN2000 V2.1 Series

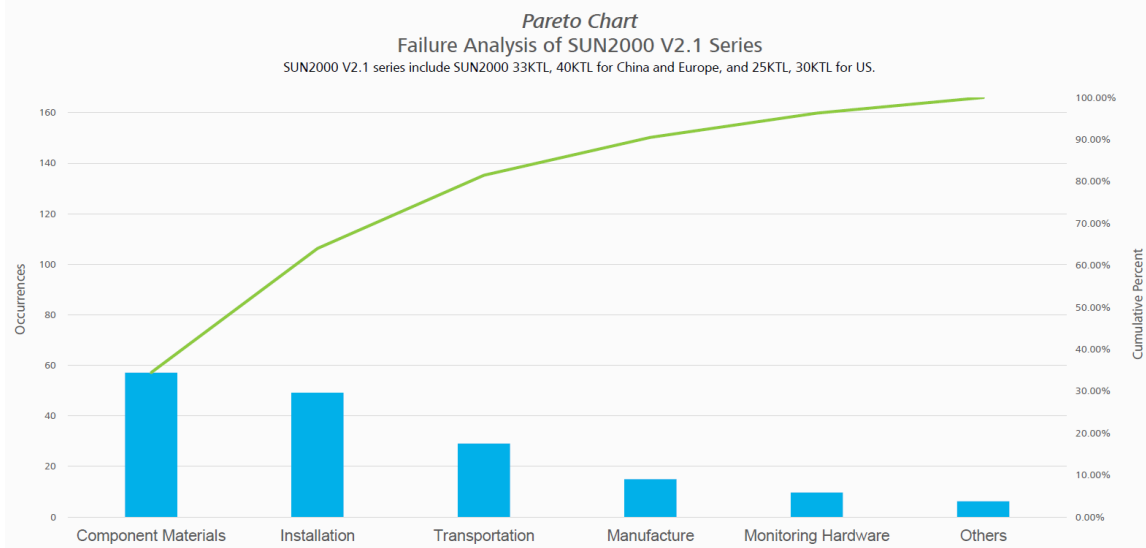

Figure 7-2: Failure Analysis of SUN2000 V2.1 Series

A Mean Time Between Failure (MTBF) analysis has been undertaken by Huawei based on all the major components within the inverter using the Telcordia SR-332 issue2 Method 1 methodology. The MTBF analysis indicates a total result of 356,810 hours (approximately 40 years). This does not mean that each inverter will last for 40 years before failing and the TA has not been provided with the calculations to verify the results. Inverters failure typically follows the bathtub curve as illustrated in Figure 7-3 with a high failure rate to be expected at the start and end of the operational period.

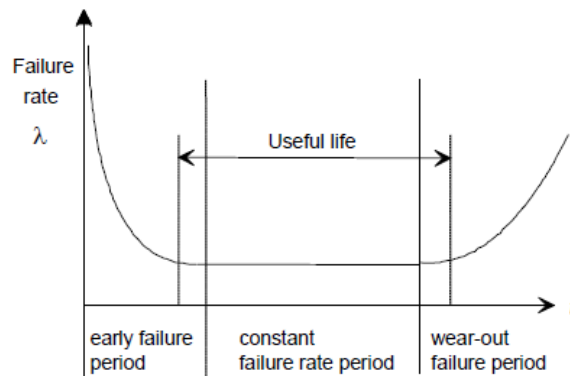

Figure 7-3: Example Bathtub Curve



An inverter fault testing report provided analyses the fault issues experienced from 10 global installations using Huawei's inverters. The fault rate is compared with the number of operational months in Figure 7-4. The report shows Huawei inverter has a low fault rate with a maximum value of 0.9% while the majority projects are reported with no faults to date. It should be considered the operational period for all 10 projects in less than 2 years, however this indicates the infant mortality rate is low.

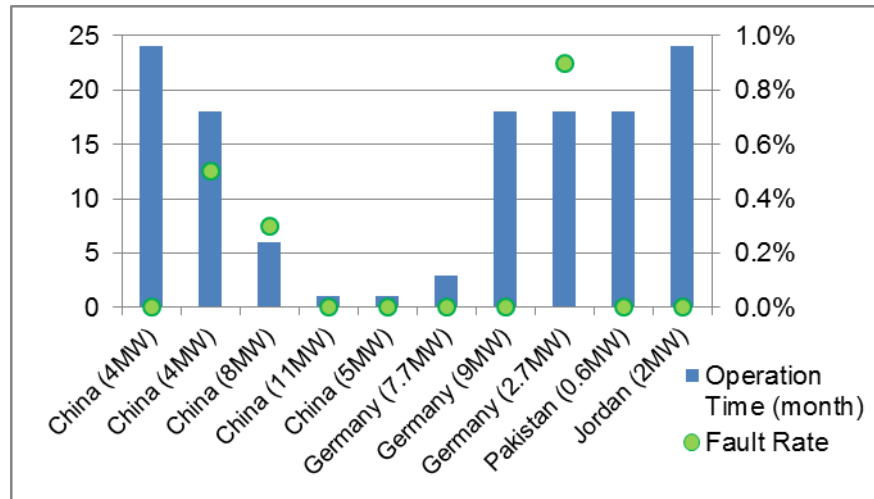

Figure 7-4: Huawei String Inverter Fault Rate

As seen in Figure 7-4, faulty inverters existed in three projects, with a single faulty inverter for each project. A root-cause analysis was undertaken by Huawei, as described in Table 7-4.

Table 7-4: Huawei Inverter Fault Analysis

Case	Germany 2.7MW	China 4MW	China 4MW
Inverter type	SUN2000-20KTL	SUN2000-20KTL	SUN2000-20KTL
Fault reason	Abnormal frequency	Short circuit	Overheating
Root cause	Inverter problem	Mishandling	Mishandling
Solution	The faulty inverter was returned and fixed at a local warehouse.	The faulty inverter was immediately replaced onsite.	The faulty inverter was replaced by Huawei within 2 days.



Case	Germany 2.7MW	China 4MW	China 4MW
Huawei comments	Carry out further training of maintenance personnel. The inverter has a small problem, however it doesn't need to be returned and can be fixed onsite.	Carry out more training for installation personnel. Inverters cannot be hot connected.	Improve user manual to highlight the introduction on fittings. Huawei inverter service team should demonstrate how to install inverters.

Two out of three faults were caused by improper installation rather than inverter quality. The only one quality problem was fixed through a firmware upgrade and no further problem has been reported so far according to Huawei.

Huawei inverters have a low failure rate during the initial operational period based on information provided to the TA. As Huawei inverters have not been installed on solar PV projects for a significant period of time, the TA is unable to confirm the failure rate over a longer period. However, according to the bath-tub curve given in Figure 7-3, the failure rate is typically highest during the infant mortality period and towards the end of the equipment lifetime.

Figure 7-5 shows the cumulative shipment and failure rate of SUN2000 from January 2014 to December 2015. It can be observed that there is a steady increase in shipments for both V1 series (SUN2000-8kTL~28kTL) and V2 series (SUN-25kTL, 30kTL, 33kTL, and 40kTL). The failure rate for the V1 series plateaus at 0.5%, and gradually decreases from 0.5% for the V2 series. In general, a failure rate of 0.5% is considered acceptable considering the number of units shipped. This trend shows that there is an improvement in build quality for the Huawei inverters over the course of these two years.



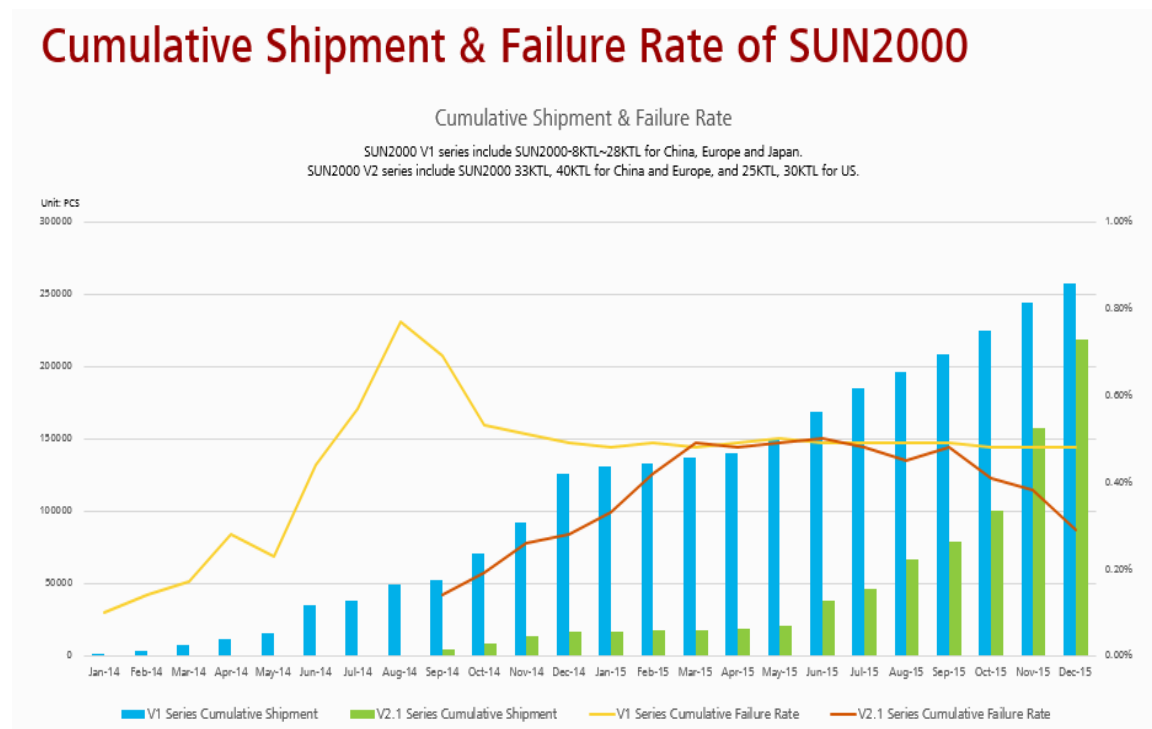

Figure 7-5: Huawei String Inverter Cumulative Shipment and Failure Rate

Overall, the TA considers the reliability of Huawei inverters to be reasonably well proven, with a significant amount of data provided for review including operational data and overall recorded failure rates, even though the inverters have not been in production for a significant period of time. Whilst inverters are typically expected to last for at least half the project lifetime of a PV plant (25 years), considering a bathtub failure rate and relatively low current failure rate for the initial period, as well as accelerated lifetime tests completed on the inverters, the TA is satisfied the inverters have a good level of reliability. The TA recommends that Huawei regularly update the installation and user manual in order to minimise inverter faults caused by improper installation and operation and continues to conduct additional accelerated lifetime testing.

7.3 Warranties and Guarantees

Huawei provides a sixty-three month (5.25 years) warranty agreement for any new-purchase SUN2000 series inverter. This is in line with current market standard for string inverters. The warranty start date is the sooner of three months after shipment of the product or the delivery date. Huawei's data logger, SmartLogger, which can be used with the inverter, has a warranty of twenty seven months (2.25 years).



The inverter warranty may also be extended by the customer up to a period of 10, 15 or 20 years at an additional cost. The extended warranty can be purchased at any time up to the end of the valid, in-date warranty, i.e. the customer is eligible to purchase a warranty extension at the last day under warranty. The terms and conditions of the extended warranty are the same as those under the standard warranty. Further options such as guaranteed availability levels or preventative and corrective maintenance support are not offered.

During the warranty period, Huawei's service solutions include help desk, remote and online technical support, and hardware replacement. The response time for remote support is typically within 30 minutes while that for hardware replacement is typically within two business days. On-site troubleshooting is also available, however needs to be paid for separately by the customer. Figure 7-6 shows the general process for responding to after-sale support requests regarding the SUN2000 inverters.

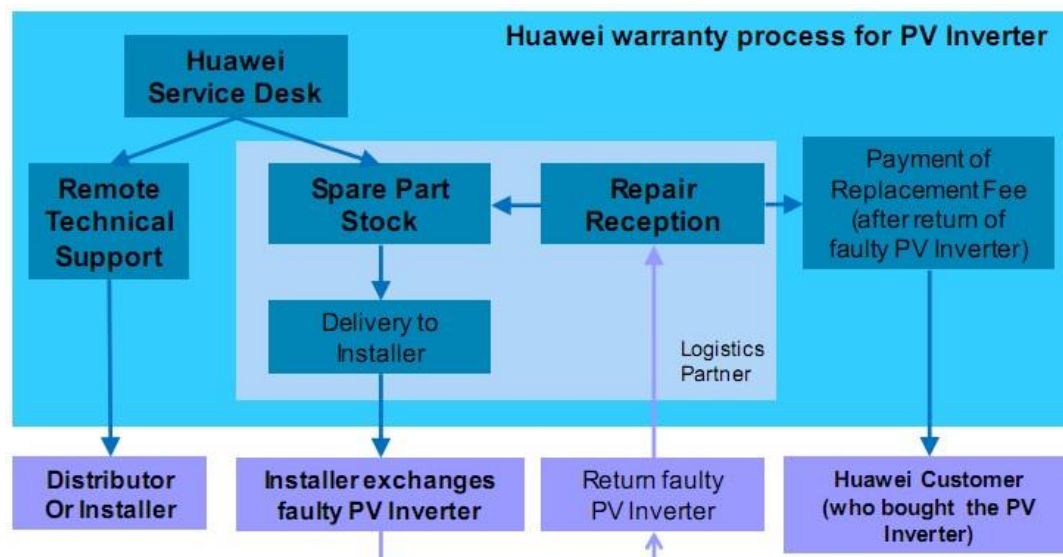

Figure 7-6: Huawei Warranty Process for PV Inverter⁴

During the warranty period, if a non-conformity or defect in the workmanship or materials is identified during normal operation, Huawei will replace the inverter with a new product that is functionally equivalent to, or better than, the defective inverter. In the UK, the inverter will typically be replaced within two working days after the warranty claim has been confirmed, which is considered a rapid replacement. For Huawei's international warranty, a spare will be replaced from China within 60 days.

If an inverter component is replaced, the new warranty period is the maximum between 12 months from the date of replacement and the remaining period of the warranty.

⁴ Huawei, SUN2000 Warranty and Service Conditions for UK and Germany, 2014



Huawei will, in some regions, e.g. the UK, pay a replacement fee to the installer company after receiving the replaced inverter along with transportation fees, which can be considered above market standard.

The warranty contains a number of exclusions including:

- Normal wear and tear or natural aging of the inverter.
- Failure to install and operate the inverter in accordance with Huawei specifications.
- Unauthorised disassembly, repair, alteration or modifications.
- Misuse, abuse, intentional damage, negligence, alteration or modifications.
- Improper testing, operation, maintenance, or installation.
- Damage due to use of incorrect voltage.
- Problems caused by system infrastructure.
- Improper storage, shipping, handling or usage of the inverters.
- Force majeure events including sabotage, fire, floods, typhoons, explosions, labour unrest amongst others.

The TA considers the list of exclusions to be reasonable, although fire caused by the inverter should not be excluded. Warranty conditions can be considered to be generally in line with market standard, with reasonable exclusions defined and positive inclusion of transport and installation cost coverage.

7.4 Huawei Technical Support

Due to the wide range of Huawei services and products, the company has a number of technical assistance centres, global spare part centres and other offices around the world, as shown in Figure 7-7.

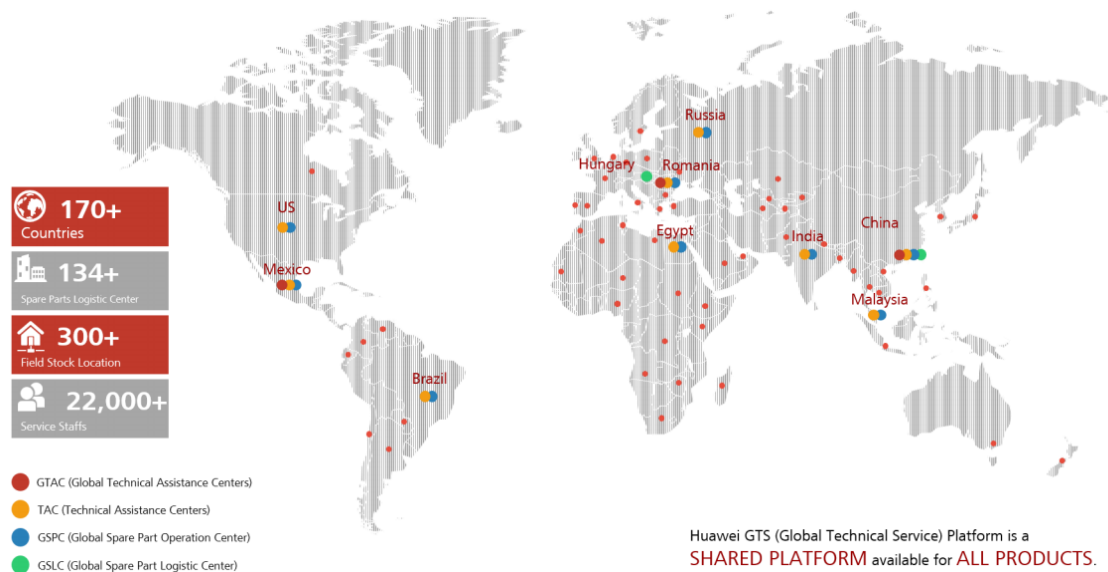

Figure 7-7: Huawei Technical Assistance and Spare Parts Centres



There are over 22,000 Huawei service staff in more than 170 countries across the world. Apart from the three global technical assistance centres in China, Romania and Mexico, the local technical assistance centre also provide services relating to Smart PV Plant Solutions for various regions such as the Americas, Japan and Korea, Asian pacific and Middle East and Africa. Over nine languages can be used to provide local services.

Global spare parts operation and logistic centres are located in Europe, America, China, Middle East and Asia pacific, areas which are convenient for hardware replacement requirements.

The TA notes that it is important that technical support teams and spare parts warehouses are available for maintaining high availability for PV system and as Huawei install further capacity around the world, this capability will increase in the respective growth regions.

7.5 Summary

The TA considers the Huawei SUN2000 series string inverter to have the required certification for use on PV plants around the world. In-house testing of the inverter and individual components is relatively extensive during the R&D phase with functional and temperature cycling testing of each manufactured inverter. A MTBF analysis was undertaken by Huawei with an expected design life stated by Huawei greater than 20 years. Warranty conditions can be considered in line with market standard, with comments provided by the TA on particular exclusions.

8 Conclusions

SgurrEnergy has conducted a review of the Huawei SUN2000 series string inverter based on information provided by Huawei through a combination of technical documentation, factory inspections, interviews of key technical and management staff and technical query correspondence. A summary of our findings is outlined below.

8.1 Company Overview

Huawei is a major global manufacturer of telecommunications equipment, including inverters for PV plants. With experience in similar technologies in the telecommunications business, Huawei has been able to develop solar inverters using similar design principles. Huawei is a rapidly growing multi-billion dollar business, with a significant proportion of revenues assigned to research and development. Huawei inverters have been used on a number of MW scale projects in Germany, China, the UK, Jordan, Austria, India and France amongst others.



8.2 Technical Characteristics

The TA believes that the design of the inverter provides a safe and efficient means of converting DC power to AC. The inclusion of two or three model dependant MPPTs increases the efficiency of the inverter in multiple operational environments such as shading, different string output powers, different modules and varied tilt angles.

The TA believes that the policy of utilising quality assured manufacturers for key components produces acceptable product quality. A large number of components are manufactured in China with the remainder manufactured by established manufacturers with strong supply chains. This gives confidence that supply chain issues will be minimised. A review of key components was undertaken and the TA believes that the components within the inverter are of good quality and suitable for use within this inverter.

The TA considers the published performance figures as at the upper range of current industry performance. These have been confirmed by independent testing by industry experts Photon who rated the SUN2000 20kTL as A+. This is one of only 4 inverters to have received this award.

8.3 Compliance to International Grid Standards

The grid codes for the UK, the USA, Germany, China, India, South Africa, Jordan and Chile have been compared against the certificates of conformity held by the inverter family. Most of the inverters reviewed are capable of operating in these countries, notwithstanding the lack of country-specific grid certifications. This is evidence that these inverters are highly adaptable to various grid requirements and can be used in PV projects within these countries. However, individual technical due diligence is required on all projects in different countries to ensure that the inverters are compliant with local regulations and codes.

8.4 EHS and Manufacturing Processes

Huawei has well-established quality, environmental, health and safety management processes in place based on an extensive history in manufacturing electronic components. Huawei has industry standard certification including ISO 9001, ISO 14001 and OHSAS 18001. The TA observed EHS procedures were adhered to during a factory inspection.

The TA considers the manufacturing process of the SUN2000 series inverters to be well-designed with appropriate quality management processes ensuring each stage is conducted to a high standard. Staff on the production line appear capable and finished inverters were of good quality.



8.5 Reliability Review

With a list of all third-party certifications for different inverter models, the TA considers the Huawei SUN2000 series string inverter to have the required certification for use on PV plants in various countries in Europe, Asia, North America, Africa and Oceania. In-house testing of the inverter and individual components is relatively extensive during the R&D phase with each inverter then functionally tested along with short-term high-temperature condition testing.

A MTBF analysis was undertaken by Huawei with an expected design life stated by Huawei greater than 20 years. A deployment failure rate of approximately 0.5% for the inverter models in Asia, Europe and North America is considered acceptable. Warranty conditions can be considered in line with market standard.

Operational data for a single inverter installation in Germany since February 2014 indicates the inverter performance is comparable with leading inverter manufacturers both in terms of performance and availability. Operational data provided for large-scale installations also indicates proven performance.

Overall, the TA considers the reliability of Huawei inverters to be reasonably well proven, with a significant amount of data provided for review including operational data and overall recorded failure rates even though the inverters have not been in production for a significant period of time. Whilst inverters are typically expected to last for at least half the project lifetime of a PV plant (25 years), considering a bathtub failure rate and relatively low current failure rate for the initial period, as well as accelerated lifetime tests completed on the inverters, the TA is satisfied that the inverters have a good level of reliability. The TA recommends that Huawei regularly updates the installation and user manual in order to minimise inverter faults caused by improper installation and operation and continues to conduct additional accelerated lifetime testing.



Appendix A: Photon International Inverter Test Results

Inverter test results										
Inverter	Observed voltage range**	Medium irradiation				High irradiation				PI issue
		eta _{Panel}	Grade as of 2011	Grade before 2011	Position	eta _{High}	Grade as of 2011	Grade before 2011	Position	
SMA's STP 2000TLHE-10**	580 - 800 V	98.5 %	A+	–	1	98.6 %	A+	–	1	12/2011
Refusol's 020k SCI	490 - 800 V	98.2 %	A+	–	2	98.3 %	A+	–	2	7/2012
Huawei Technologies Co. Ltd.'s Sun2000-20KTL	480 - 800 V	98.0 %	A+	–	3	98.1 %	A+	–	3	6/2013
Diehl AKO's Platinum 16000 R3	350 - 720 V	98.0 %	A+	–	3	98.0 %	A+	–	4	3/2013
Donauer Solartechnik's High Efficiency 3.6	350 - 650 V	97.8 %	A	–	5	97.9 %	A	–	5	12/2012
Steca's StecaGrid 3600	350 - 600 V	97.7 %	A	–	6	97.8 %	A	–	6	12/2011
Steca's Stecagrid 3000	350 - 700 V	97.5 %	A	–	7	97.8 %	A	–	6	9/2012
Siemens' Sinvert PVM20	480 - 850 V	97.5 %	A	–	7	97.7 %	A	–	8	4/2011
Sungrow's SG30KTL	480 - 800 V	97.5 %	A	–	7	97.7 %	A	–	8	2/2013
Siemens' Sinvert PVM17	460 - 850 V	97.4 %	A	–	10	97.7 %	A	–	8	4/2011
Refusol's 017K	460 - 850 V	97.4 %	A	A+	10	97.6 %	A	A+	11	12/2010
Global Mainstream Dynamic's Soldate 318KTL	490 - 800 V	97.3 %	A	–	12	97.6 %	A	–	11	–**
Refusol's 013K	420 - 850 V	97.3 %	A	A+	12	97.6 %	A	A+	11	12/2010
Siemens' Sinvert PVM13	420 - 850 V	97.3 %	A	–	12	97.3 %	A	–	11	4/2011
Refusol's 020K	480 - 850 V	97.3 %	A	–	12	97.5 %	A	–	15	3/2012
SMA's STP 17000TL	400 - 800 V	97.3 %	A	A+	12	97.5 %	A	A+	15	12/2010
SMA's STP 10000TL-10	320 - 800 V	97.1 %	A	–	17	97.5 %	A	–	15	10/2011
Chint Power's CPS SC20KTL-0	500 - 800 V	97.1 %	A	–	17	97.4 %	A	–	18	11/2011
Siemens' Sinvert PVM10	380 - 850 V	97.0 %	A	–	19	97.4 %	A	–	18	1/2011
Delta Energy Systems' Solivia 20 EU G3 TL	350 - 800 V	97.0 %	A	–	19	97.2 %	A	–	22	3/2012
Zeversolar New Energy's Eversol-TLC 17k**	550 - 720 V	96.9 %	A	–	21	97.3 %	A	–	20	4/2011
Mastervolt's Sunmaster CS20TL	350 - 800 V	96.9 %	A	–	21	97.2 %	A	–	22	5/2011
Power-One's Trio-27.6-TL-OUTD-S2-400	500 - 800 V	96.9 %	A	–	21	97.2 %	A	–	22	2/2013
Refusol's 011K**	380 - 800 V	96.9 %	A	A+	21	97.2 %	A	A+	22	9/2008
Goodwe Power Supply Technology's GW4000-SS	280 - 500 V	96.9 %	A	–	21	97.1 %	A	–	26	12/2012
SMA's SMC 8000 TL**	335 - 487 V	96.9 %	A	A+	21	97.0 %	A	A+	30	10/2007
SMA's SMC 11000TL**	333 - 500 V	96.9 %	A	A+	21	96.8 %	A	A+	43	7/2010
B&B Power's SF 4600TL	250 - 500 V	96.8 %	A	–	28	97.3 %	A	–	20	–**
Growatt's 5000MTL (version 2)	250 - 540 V	96.8 %	A	–	28	97.1 %	A	–	26	12/2012
Sputnik's Solarmax 13MT**	250 - 750 V	96.8 %	A	–	28	97.1 %	A	–	26	9/2011
Diehl AKO's Platinum 6300 TL**	350 - 710 V	96.8 %	A	A+	28	96.9 %	A	A+	40	2/2009
Power-One's TRIO-20.0-TL-OUTD S2-400	410 - 800 V	96.7 %	A	–	32	97.1 %	A	–	26	9/2012
Danfoss' TLX 15 k	430 - 800 V	96.7 %	A	A+	32	97.0 %	A	A+	30	6/2010
Samil Power's Solarlake 15000TL	380 - 800 V	96.7 %	A	–	32	97.0 %	A	–	30	6/2012
Zeversolar New Energy's Eversol-TL 4600	290 - 500 V	96.7 %	A	–	32	97.0 %	A	–	30	9/2011
Sunways' NT 4200	340 - 750 V	96.7 %	A	A+	32	96.8 %	A	A+	43	3/2010
Sunways' PT33k	460 - 800 V	96.7 %	A	–	32	96.8 %	A	–	43	6/2012
Conergy's IPG 15T	450 - 800 V	96.6 %	A	A+	38	97.0 %	A	A+	30	8/2010
Kinglong's KLNE Solartec D 15000	480 - 750 V	96.6 %	A	–	38	97.0 %	A	–	30	3/2013
Kinglong's KLNE Sunteams 5000	280 - 440 V	96.6 %	A	–	38	97.0 %	A	–	30	5/2012
Sungrow's SG15KTL	380 - 800 V	96.6 %	A	–	38	97.0 %	A	–	30	2/2012
SMA's SMC 7000TL**	333 - 500 V	96.6 %	A	A+	38	96.8 %	A	A+	43	5/2010
Sunways' NT 11000	340 - 750 V	96.6 %	A	–	38	96.7 %	A	–	51	11/2012
Danfoss' TLX 10 k	430 - 800 V	96.5 %	A	A+	44	97.0 %	A	A+	30	8/2010
Eaton Phoenixtec MMPL's SV 20000s	450 - 850 V	96.5 %	A	–	44	96.8 %	A	–	43	5/2013
Samil Power's Solarriver SR4K4TLA1	200 - 500 V	96.5 %	A	–	44	96.8 %	A	–	43	8/2011
Eltek Valere's Theia 4.4HE-t**	230 - 480 V	96.5 %	A	–	44	96.7 %	A	–	51	11/2011
Power-One's Aurora PVI-12.5-OUTD-FS**	360 - 750 V	96.4 %	B	A	48	96.9 %	A	A+	40	4/2010
SLD Power Technology's SLS5KH65	225 - 500 V	96.4 %	B	–	48	96.7 %	A	–	51	5/2013
B&B Power's SF 3000TL	250 - 450 V	96.3 %	B	–	50	96.9 %	A	–	40	4/2013
Helios' HSI20	350 - 800 V	96.2 %	B	–	51	97.0 %	A	–	30	3/2012
Growatt's 5000 MTL	250 - 550 V	96.2 %	B	–	51	96.8 %	A	–	43	7/2012
Kaco's Powador 4000 supreme DCS (9 kHz)	350 - 510 V	96.2 %	B	A	51	96.7 %	A	A+	51	1/2010
Kstar's New Energy KSG-5K (version 2)	280 - 480 V	96.2 %	B	–	51	96.6 %	A	–	55	12/2012
Kstar's New Energy KSG-3	190 - 440 V	96.1 %	B	–	55	96.6 %	A	–	55	8/2012
Tranergy's PVI 4600TL	300 - 500 V	96.1 %	B	–	55	96.6 %	A	–	55	8/2012
Growatt's 5000 TL**	280 - 500 V	96.0 %	B	–	57	96.8 %	A	–	43	2/2011
Fronius' IG TL 5.0	350 - 700 V	95.9 %	B	A	58	96.2 %	B	A	59	9/2010
Kaco's Powador 4000 supreme DCS (18 kHz)	350 - 510 V	95.7 %	B	A	59	96.1 %	B	A	60	1/2010
SMA's SB 5000TL-20**	175 - 440 V	95.7 %	B	A	59	96.0 %	B	A	62	5/2009
Sungrow's SG4KTL	210 - 420 V	95.6 %	B	–	61	96.3 %	B	–	58	1/2011

** range at which the model was tested and to which the grade applies. ** Eversolar New Energy Co. Ltd. and Zof New Energy Co. Ltd. merged at the end of 2011 and altered their name to Zeversolar New Energy Co. Ltd.; Zeversolar now calls the device the Eversol TL 17k; however, the power data differs from the tested Eversol-T. ** device no longer being produced, ** renamed Solarmax 13MT3 since April 2012. ** name changed from Eltek Valere to Eltek. ** now Schneider Electric Industries SA. ** prototype; device no longer being produced, ** the identical solar inverter brands Helios Power (Riello UPS) and Sirio (AROS) are now marketed under a single brand, AROS Solar Technology GmbH, and distributed by AROS Neufahrn. ** inverters that have been already tested by PHOTON Lab, but results are not yet published in the magazine

