

INSTRUCTIONS:

- * FOR USAGE OF TYPE A OR TYPE B PIPE, REFER TO D.M.2, TABLE 10.3.5
- * FOR DIAMETERS GREATER THAN 48", USE TYPE A DESIGN FILL HEIGHT TABLES.
- * LOCAL AUTHORITIES MAY USE TYPE B OR TYPE A DESIGN FILL HEIGHT TABLES.
- * SPECIFY SHORING/TRENCH BOX INSTALLATION IF REQUIRED BY SITE CONDITIONS.
- * USE PAIDD COMPUTER PROGRAM TO PERFORM PIPE DESIGNS FOR REQUIRED FILL HEIGHTS AND CONCRETE STRENGTHS NOT SHOWN IN THE DESIGN TABLES ON SHEET 4 AND SHEETS 6 THRU 10, INDICATED BY DOUBLE ASTERISKS (**).
- * REFER TO SHEET 3 FOR ADDITIONAL INSTRUCTIONS FOR USAGE OF THIS STANDARD.

DEFINITIONS:

- DIA = INSIDE DIAMETER OF THE CONCRETE PIPE.
- TYPE A STANDARD INSTALLATION = HEAVY-DUTY CONCRETE PIPE EMBANKMENT INSTALLATION DESIGN (APPROXIMATELY 100-YEAR LIFE).
- TYPE A SHORING/TRENCH BOX INSTALLATION = HEAVY-DUTY CONCRETE PIPE TRENCH BOX OR SHORING INSTALLATION DESIGN (APPROXIMATELY 100-YEAR LIFE).
- TYPE B STANDARD INSTALLATION = STANDARD DUTY CONCRETE PIPE EMBANKMENT INSTALLATION DESIGN (APPROXIMATELY 50-YEAR LIFE).
- TYPE B SHORING/TRENCH BOX INSTALLATION = STANDARD DUTY CONCRETE PIPE TRENCH BOX OR SHORING INSTALLATION DESIGN (APPROXIMATELY 50-YEAR LIFE).
- PROOF TEST LOAD = THREE EDGE BEARING TEST TO A LOAD EXTRAPOLATED FROM 0.007" DESIGN REQUIREMENT TO PRODUCE A 0.01" CRACK.
- PROOF LOAD = THE LOAD CARRIED BY A PIPE SUBJECTED TO A THREE EDGE BEARING TEST, EXPRESSED IN POUNDS PER LINEAR FOOT OF INSIDE DIAMETER. THE PROOF LOAD REFLECTS THE FIELD SERVICE LOAD CONDITION FOR BOTH LIVE AND DEAD LOADS.
- PAIDD = PENNSYLVANIA INSTALLATION DIRECT DESIGN.
- H = DESIGN FILL HEIGHT, FT.
- f_y = SPECIFIED YIELD STRENGTH OF REINFORCEMENT ksi
- f'c = SPECIFIED COMPRESSIVE STRENGTH OF CONCRETE ksi
- HAF = HORIZONTAL ARCHING FACTOR
- VAF = VERTICAL ARCHING FACTOR
- D_m = 1 FOR UNITY
- A1 - A6 = COEFFICIENTS WHICH REPRESENT THE INTEGRATION OF NON-DIMENSIONAL VERTICAL AND HORIZONTAL COMPONENTS OF SOIL PRESSURE UNDER THE INDICATED PORTIONS OF THE COMPONENT PRESSURE DIAGRAMS (AREA UNDER COMPONENT PRESSURE DIAGRAMS).
- a, b, c, d, e, f, u, v = NON-DIMENSIONAL COEFFICIENTS DEFINING HORIZONTAL AND VERTICAL DIMENSIONS OF COMPONENT PRESSURE REGIONS.
- d = 0.5 - c - e
- h₁ = $\frac{(1.5a1)}{c(1+u)}$
- h₂ = $\frac{(1.5A2)}{[(d)(1+v) + (2e)]}$
- SPAN RATIO = SPAN ELLIPTICAL/EQUIVALENT ROUND = 1.28
- RISE RATIO = RISE ELLIPTICAL/EQUIVALENT ROUND = 0.63
- VAF = VAF ROUND
- HAF = (RISE RATIO/SPAN RATIO) (HAF ROUND PIPE) = 0.49 (HAF ROUND PIPE)

PROCEDURE FOR EARTH LOAD MODELING:

CONSULT THE "CONCRETE PIPE TECHNOLOGY HANDBOOK", 1993 (PUBLISHED BY THE AMERICAN CONCRETE PIPE ASSOCIATION), CHAPTER 8, OR APPENDIX H OF THE DESIGN MANUAL PART 4, STRUCTURES, FOR A PROCEDURE FOR EARTH LOAD MODELING.

NOTES:

1. FABRICATE CONCRETE PIPE AS PER PUBLICATION 280 ENTITLED "PENNSYLVANIA INSTALLATION DIRECT DESIGN MANUFACTURING SPECIFICATION".
2. SEE RC-30M AND PUBLICATION 408, SECTIONS 601 AND 604 FOR INSTALLATION OF CONCRETE PIPES.
3. DESIGN CONCRETE PIPE IN ACCORDANCE WITH PENNSYLVANIA INSTALLATION DIRECT DESIGN (PAIDD), AND APPENDIX H OF DESIGN MANUAL, PART 4, STRUCTURES.
4. TEST CONCRETE PIPES IN ACCORDANCE WITH PUBLICATION 408 AND PROOF TEST LOAD TABLES [PRESENTED IN THIS STANDARD AND IN PUBLICATION 280]. PROOF TEST LOADS INCLUDE A 1.43 FACTOR OF SAFETY FOR FIELD CRACKING. TESTING TO ULTIMATE IS NOT REQUIRED.
5. REFERENCE RC-30M FOR MINIMUM FILL HEIGHT AND COVER REQUIREMENTS FOR CONCRETE PIPES.
6. THE DESIGN VALUES SHOWN IN THIS STANDARD ARE BASED UPON THE ASSUMPTION THAT THE EXCAVATION, BACKFILL AND CONSTRUCTION METHODS IN THE RC STANDARDS AND PUBLICATION 408 ARE USED.
7. ELLIPTICAL REINFORCEMENT IS NOT PERMITTED, EXCEPT FOR QUADRANT REINFORCEMENT AND FOR REINFORCEMENT OF ELLIPTICAL PIPE.
8. SMOOTH WELDED WIRE FABRIC IS USED IN THE DESIGN OF THE STEEL AREAS FOR CONCRETE PIPE. USE OF DEFORMED WIRE FABRIC OR DEFORMED WIRE IS PERMITTED.
9. USE DESIGN TABLES GIVEN IN THIS STANDARD TO DETERMINE STEEL AREA. USE PAIDD SOFTWARE FOR DESIGNS NOT COVERED BY THESE TABLES.
10. STEEL AREAS ARE SHOWN AS, IN.²/FT.
11. PROVIDE ADDITIONAL CONCRETE COVER FOR ACIDIC (pH ≤ 4) OR ABRASIVE ENVIRONMENTS.
12. ENSURE THAT CONSTRUCTION CONDITIONS (SHALLOW FILLS AND CONSTRUCTION TRAFFIC, IF APPLICABLE) ARE CONSIDERED AT THE TIME THE PIPE IS SPECIFIED.
13. A 2 FT. SPACING IS REQUIRED (A 3 FT. SPACING IS PREFERRED) FOR MULTIPLE PIPES [SEE PAIDD SPECIFICATIONS FOR SKETCH].
14. PIPE MAY NOT BE PLACED WITHIN THE PAVEMENT STRUCTURE WITHOUT CHIEF BRIDGE ENGINEER APPROVAL.

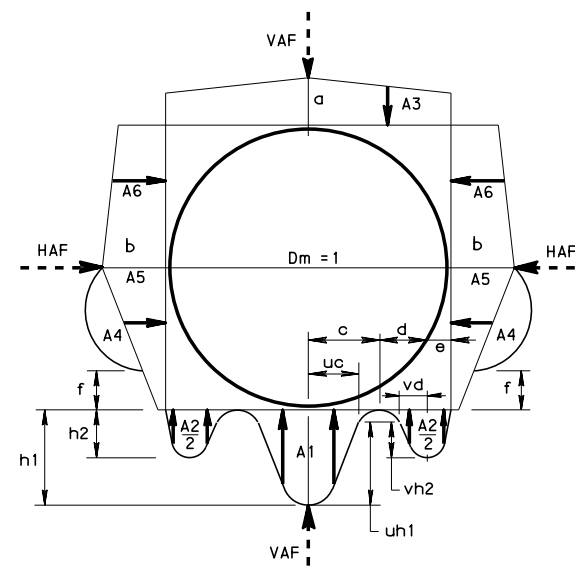

SOIL PRESSURE DISTRIBUTION MODEL

**COMMONWEALTH OF PENNSYLVANIA
DEPARTMENT OF TRANSPORTATION
BUREAU OF PROJECT DELIVERY**

**STANDARD
REINFORCED CONCRETE PIPES
DESIGN CRITERIA**

RC-30M	SUBSURFACE DRAINS - PIPE PLACEMENT EXCAVATION - BEDDING - BACKFILL	RECOMMENDED APR. 29, 2016	RECOMMENDED APR. 29, 2016	SHEET 1 OF 10
	REFERENCE DRAWINGS	<i>Thomas P. Maiore</i> CHIEF BRIDGE ENGINEER	<i>Brenda S. Thomas</i> DIRECTOR, BUR. OF PROJECT DELIVERY	BD-636M

TABLE A

DESIGN DATA				
ITEMS	STANDARD INSTALLATION		TRENCH BOX/SHORING INSTALLATION	
	TYPE A	TYPE B	TYPE A	TYPE B
INSTALLATION TYPE	PAIDD	PAIDD	PAIDD	PAIDD
HAUNCH COMPACTION	95% MIN.	95% MIN.	60% MIN.	60% MIN.
SOIL WEIGHT	140 lbs./ft. ³	140 lbs./ft. ³	140 lbs./ft. ³	140 lbs./ft. ³
LIVE LOAD	HS 25	HS 25	HS 25	HS 25
f _y	65,000 psi	65,000 psi	65,000 psi	65,000 psi
f'c	MIN. 4,000 psi	MIN. 4,000 psi	MIN. 4,000 psi	MIN. 4,000 psi
CONCRETE COVER	1" OVER STEEL	1" OVER STEEL	1" OVER STEEL	1" OVER STEEL
LOAD FACTORS*	TYPE A	TYPE B	TYPE A	TYPE B
DEAD LOAD & EARTH LOAD FACTOR (SHEAR & MOMENT)	1.30	1.30	1.30	1.30
DEAD LOAD FACTOR (THRUST) †	1.00	1.00	1.00	1.00
REINFORCEMENT DESIGN CONCRETE COMPRESSION	1.30	1.30	1.30	1.30
LIVE LOAD FACTOR (SHEAR & MOMENT)	2.17	2.17	2.17	2.17
LIVE LOAD FACTOR (THRUST)	1.00	1.00	1.00	1.00
INTERNAL PRESSURE LOAD FACTORS (THRUST)	1.50	1.50	1.50	1.50
IMPACT (TO MAX. 8' HEIGHT)	40 [1.0-0.125H] ≥ 10%	40 [1.0-0.125H] ≥ 10%	40 [1.0-0.125H] ≥ 10%	40 [1.0-0.125H] ≥ 10%
STRENGTH REDUCTION (Φ FACTORS) ‡	TYPE A	TYPE B	TYPE A	TYPE B
FLEXURE	0.90	0.95	0.90	0.95
RADIAL TENSION	0.85	0.90	0.85	0.90
DIAGONAL TENSION	0.85	0.90	0.85	0.90
CRACK CONTROL FACTOR	0.7	0.7	0.7	0.7
ORIENTATION ANGLE	± 10°	± 10°	± 10°	± 10°
MATERIAL & PROCESS FACTORS	TYPE A	TYPE B	TYPE A	TYPE B
RADIAL TENSION	1.0	1.0	1.0	1.0
DIAGONAL TENSION	1.0	1.0	1.0	1.0
EMBANKMENT ARCHING FACTORS*				
VAF (VERTICAL)	1.35	1.35	SEE TABLE 'C'	SEE TABLE 'C'
HAF (HORIZONTAL)	0.45	0.45		

TABLE B

ARCHING COEFFICIENTS															
INSTALLATION TYPE	VAF	HAF	A1	A2	A3	A4	A5	A6	a	b	c	e	f	u	v
EMBANKMENT	1.35	0.45	0.62	0.73	1.35	0.19	0.08	0.18	1.40	0.40	0.18	0.08	0.05	0.80	0.80
TRENCH BOX OR SHORING	*	*	1.45	0.00	1.45	0.00	0.11	0.19	1.45	0.30	0.25	0.00	--	0.90	--

* SEE TABLE 'C'

TABLE C

FACTORS FOR TRENCH BOX OR SHORING INSTALLATION*				
REQUIRED FILL HEIGHT FT.	12" THROUGH 36" DIAMETER		42" THROUGH 120" DIAMETER	
	VAF	HAF	VAF	HAF
1.5	1.20	0.29	1.20	0.29
2.0	1.15	0.29	1.20	0.29
3.0	1.00	0.25	1.20	0.25
7.0	0.70	0.18	0.90	0.18
10.0	0.70	0.16	0.90	0.16
15- 25	0.70	0.12	0.80	0.12

* BEDDING FACTOR USED TO DETERMINE PROOF TEST LOAD 1.60 FOR EARTH LOADS. LIVE LOAD BEDDING FACTOR AS PER ACPA "DESIGN DATA 40" DECEMBER, 1992.

TABLE D

FACTORS FOR TRENCH BOX OR SHORING INSTALLATION FOR ELLIPTICAL PIPE										
REQUIRED FILL HEIGHT FT.	EQUIVALENT ROUND		HORIZONTAL ELLIPTICAL				VERTICAL ELLIPTICAL			
	VAF	HAF	VAF		HAF		VAF		HAF	
			12"to 36"	42"to 120"	12"to 36"	42"to 120"	12"to 36"	42"to 120"		
1.5	1.20	0.29	1.20	1.20	0.18	0.18	1.20	1.20	0.46	0.46
2.0	1.10	0.22	1.15	1.20	0.18	0.18	1.15	1.20	0.46	0.46
3.0	1.10	0.22	1.00	1.20	0.16	0.16	1.00	1.20	0.40	0.40
7.0	0.90	0.16	0.70	0.90	0.10	0.10	0.70	0.90	0.29	0.29
10.0	0.80	0.12	0.70	0.90	0.10	0.10	0.70	0.90	0.25	0.25
15- 25			0.70	0.90	0.08	0.08	0.70	0.90	0.19	0.19

FLEXURE-SHEAR-CRACK CONTROL RELATIONSHIP

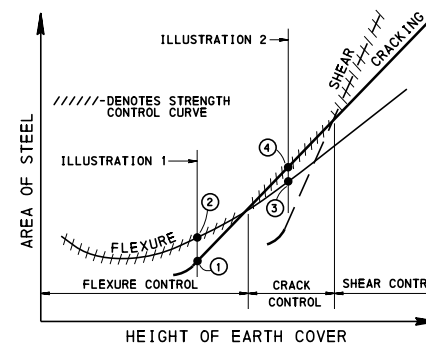

EXAMPLE: TYPE B 48" STANDARD INSTALLATION

	24<H<3	36<H<7
WALL THICKNESS	5 3/4"	5 3/4"
AREA OF STEEL:		
INNER CAGE	= 0.15 SQ. IN.	0.14 SQ. IN.
OUTER CAGE	= 0.09 SQ. IN.	0.07 SQ. IN.
PROOF TEST LOAD	= 587 LBS.	823 LBS.

AS SEEN HERE, THE ACTUAL STRENGTH OF THE 3' TO 2' PIPE IS GREATER THAN THE 7' TO 3' PIPE AS REFLECTED BY THE STEEL AREA. THE PROOF LOAD TEST BEING A SERVICE LOAD CONDITION REFLECTS THE ANTICIPATED FIELD LOAD. THE ULTIMATE STRENGTH DESIGN METHOD USED TO DETERMINE STEEL AREAS HAS GREATER DESIGN SAFETY FACTOR FOR LIVE LOADS THAN FOR DEAD LOADS. FOR THIS REASON, THE PROOF LOAD, FOR LOW FILL HEIGHTS, IS NOT A LINEAR RELATIONSHIP WITH THE STEEL AREA.

ILLUSTRATION 1:

1. CRACK CONTROL
2. FLEXURE CONTROL

IN THIS ILLUSTRATION OF THE FLEXURE-SHEAR-CRACK CONTROL RELATIONSHIP, THE PROOF TEST LOAD FOR THIS CASE IS NOT A GOVERNING FACTOR SINCE FLEXURE CONTROLS THE DESIGN.

ILLUSTRATION 2:

3. FLEXURE CONTROL
4. CRACK CONTROL

IN THIS ILLUSTRATION OF THE FLEXURE-SHEAR-CRACK CONTROL RELATIONSHIP, THE PROOF TEST LOAD FOR THIS CASE IS A GOVERNING FACTOR SINCE FLEXURE IS NOT CONTROLLING THE DESIGN.

NOTE: PROOF LOADS ARE AN INDICATION OF CRACK CONTROLS AND NOT NECESSARILY STRENGTH CONTROL. ACTUAL STRUCTURAL DESIGN (CONCRETE STRENGTH, AREA OF STEEL AND WALL THICKNESS) IS BASED UPON FLEXURE, CRACKING, OR SHEAR - WHICHEVER GOVERNS. FOR SUBSTITUTION OF PIPES, RELY UPON THE MAXIMUM/MINIMUM FILL HEIGHT STAMP. DO NOT USE THE PROOF LOAD FOR SUBSTITUTION PURPOSES.

COMMONWEALTH OF PENNSYLVANIA
DEPARTMENT OF TRANSPORTATION
BUREAU OF PROJECT DELIVERY

STANDARD
REINFORCED CONCRETE PIPES
DESIGN CRITERIA

REINFORCED CONCRETE PIPE DESIGN EXAMPLES:

① DESIGN OF A 48" DIAMETER CONCRETE PIPE UNDER 3'-0" OF FILL.

TYPE A (HEAVY-DUTY) SOLUTION:

- * DESIGNER DETERMINES THAT A 48" DIAMETER PIPE IS REQUIRED AND THAT THE MAXIMUM FILL HEIGHT IS 3'-0". END TREATMENT AND A STANDARD TYPE A INSTALLATION AS PER RC-30M ARE SPECIFIED.
- * ITEM #0601-7072 IS SPECIFIED. FILL RANGE 10' TO 2'.
- * FABRICATOR REFERENCES PUBLICATION 280 "PAIDD MANUFACTURING SPECIFICATION" FOR A 48" DIAMETER TYPE A STANDARD INSTALLATION PIPE. A 5" WALL THICKNESS AND $f'c = 4000$ PSI ARE SELECTED FOR 48" DIAMETER. THE AREA OF STEEL REQUIRED FOR A 3' <math>H < 7'2 FOR THE INSIDE CAGE AND 0.12 IN.² FOR THE OUTER CAGE.
- * THE PIPE IS TESTED TO A PROOF TEST LOAD OF 867 LBS./LF AND MARKED PA 48A/S10-2.

TYPE B (STANDARD DUTY) SOLUTION:

- * DESIGNER DETERMINES THAT A 48" DIAMETER CONCRETE PIPE IS REQUIRED AND THAT THE MAXIMUM FILL HEIGHT IS 3'-0", END TREATMENT AND A STANDARD TYPE B INSTALLATION AS PER RC-30M ARE SPECIFIED.
- * ITEM #0601-7370 IS SPECIFIED. FILL RANGE 10' TO 3'.
- * FABRICATOR REFERENCES PUBLICATION 280 "PAIDD MANUFACTURING SPECIFICATION" FOR A 48" DIAMETER TYPE B STANDARD INSTALLATION PIPE. A 5 3/4" WALL THICKNESS AND $f'c = 5000$ PSI ARE SELECTED FOR 48" DIAMETER. THE AREA OF STEEL REQUIRED FOR A 3' <math>H < 7'2 FOR THE INSIDE CAGE AND 0.07 IN.² FOR THE OUTER CAGE.
- * THE PIPE IS TESTED TO A PROOF TEST LOAD OF 823 LBS./LF AND MARKED PA 48B/S10-3.

② DESIGN OF A 36" DIAMETER CONCRETE PIPE UNDER 9' OF FILL IN A TRENCH BOX INSTALLATION.

SOLUTION:

- * DESIGNER DETERMINES THAT A 36" DIAMETER PIPE IS REQUIRED AND MAXIMUM FILL HEIGHT IS 9'-0". END TREATMENT AND A TYPE A TRENCH BOX INSTALLATION AS PER RC-30M ARE SPECIFIED.
- * ITEM #0601-7537 IS SPECIFIED. FILL RANGE 10' TO 7'.

- * FABRICATOR REFERENCES PUBLICATION 280 "PAIDD MANUFACTURING SPECIFICATION" FOR A 36" DIAMETER TYPE A SHORING/TRENCH BOX INSTALLATION PIPE. A DOUBLE CAGE, 4" WALL THICKNESS AND $f'c = 4000$ PSI ARE SELECTED FOR A 36" DIAMETER. THE AREA OF STEEL REQUIRED FOR A 7' <math>H < 10'2 FOR THE INSIDE CAGE AND 0.07 IN.² FOR THE OUTER CAGE.
- * THE PIPE IS TESTED TO A PROOF TEST LOAD OF 1174 LBS./LF AND MARKED PA 36A/SH10-7.

RESPONSIBILITIES FOR DESIGN, FABRICATION AND INSTALLATION OF CONCRETE PIPES

DESIGNER:

1. DETERMINES DIAMETER OF PIPE REQUIRED BY HYDRAULICS.
2. DETERMINES MAXIMUM HEIGHT OF FILL.
 - FOR LONG PIPE RUNS, THE LENGTH MAY BE DIVIDED INTO SEGMENTS (DEPENDING UPON INLET LOCATIONS) WHICH MAY HAVE DIFFERENT MAXIMUM FILL HEIGHTS.
 - CONSIDERS THE EFFECT OF FUTURE WIDENING AND LOADS FOR THE PIPE DESIGN.
3. ENSURES THAT THE SIDE SLOPE IS STABLE AND THAT THE PIPE IS NOT EXPECTED TO PROVIDE SLOPE STABILITY.
4. SPECIFY CONCRETE PIPES AS INDICATED IN PUB. 280, SECTION 17.1.2. FOR PIPES WITH I.D. $\geq 8'$ PREPARE S-DRAWINGS WHICH INCLUDE 2 CORE BORINGS AND A HEADWALL DESIGN ON THE DRAWING.
5. SPECIFIES END TREATMENTS AS PER RC-30M.
6. SPECIFIES INCREASED WALL THICKNESS, IF WARRANTED FOR ACIDIC OR ABRASIVE CONDITIONS.
7. SPECIFIES TRENCH BOX/SHORING INSTALLATION IF REQUIRED.
8. SPECIFIES PROPER ITEM NUMBER.

CONTRACTOR:

1. SELECTS THE TYPE OF PIPE INSTALLATION, I.E., EMBANKMENT OR TRENCH BOX/SHORING.
2. SUBMITS SPECIAL DESIGNS TO THE MATERIALS & TESTING DIVISION OF PENNDOT.
3. INSTALLS THE PIPE AS PER RC-30M.

FABRICATOR:

1. USES PRE-APPROVED DESIGNS [PAIDD/BD-636M, TABLES ON SHEETS 4 THRU 10 UNLESS A SPECIAL DESIGN IS REQUIRED.
2. ENSURES THAT THE PROPER STRUCTURE DESIGN FOR THE PIPE IS SELECTED, TESTED AND DELIVERED.
3. PROVIDES DESIGN AND DETAILS FOR SPECIAL DESIGN PIPES.
4. CONDUCTS PROOF LOAD TESTS ACCORDING TO PUB. 280 TO PROOF TEST LOAD VALUES SPECIFIED IN PUB. 280 OR BD-636M.

PENNDOT MATERIALS AND TESTING DIVISION:

1. WITNESSES PROOF LOAD TESTS, CONDUCTS Q/A AT FABRICATION SHOP, AND APPROVES/REJECTS PIPES AT THE PLANT PRIOR TO LOADING THE PIPES FOR TRANSPORTATION TO THE JOB SITE.
2. APPROVES DESIGNS WHICH MEET THIS STANDARD OR PAIDD.
3. PROVIDES SPECIAL DESIGNS TO THE BRIDGE QUALITY ASSURANCE DIVISION FOR APPROVAL.
4. MONITORS CONCRETE STRENGTHS AND OTHER MATERIAL PROPERTIES. ENSURES THAT ONLY APPROVED [SPECIFIED IN PA MATERIALS SPECIFICATION PUB 280] SHEAR REINFORCEMENT IS USED.
5. APPROVES SHOP DETAILS, ETC.
6. COORDINATES EFFORTS TO RESOLVE PIPE FAILURE/PROBLEMS.

DISTRICT CONSTRUCTION UNIT:

1. INSPECTS PIPE PRIOR TO INSTALLATION.
2. MONITORS INSTALLATION, ENSURING ALL STEPS IN RC-30M AND PUB. 408 ARE FOLLOWED.
3. INSPECTS PIPE AFTER THE SPECIFIED FILL IS PLACED.
4. ACCEPTS PIPES IN ACCORDANCE WITH PUB. 408.

BUREAU OF PROJECT DELIVERY:

1. MAINTAINS AND UPDATES THIS STANDARD, RC-30M, SPECIAL PROVISIONS, PUB. 408 AND PAIDD THROUGH PENNSYLVANIA CONCRETE PIPE ASSOCIATION.
2. REVIEWS AND APPROVES SPECIAL DESIGNS SUBMITTED BY THE MATERIALS AND TESTING DIVISION.
3. ASSISTS THE BUREAU OF CONSTRUCTION AND DISTRICTS IN RESOLUTION OF STRUCTURAL PROBLEMS.

SIDE SLOPE CONDITION

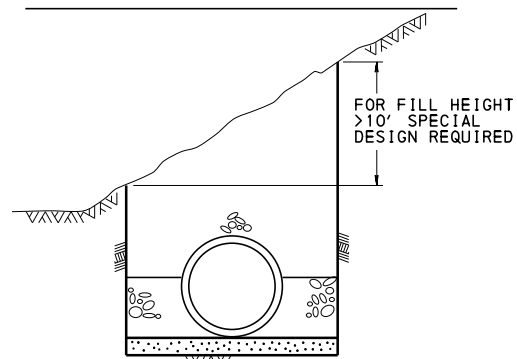

SYMMETRICAL REINFORCEMENT IS REQUIRED FOR INSTALLATIONS WHERE SIDE SLOPE CONDITIONS EXIST. A SPECIAL DESIGN IS REQUIRED WHEN THE FILL HEIGHT VARIES MORE THAN 10' OVER THE TRENCH WIDTH.

CONCRETE PIPE LOADING CURVE

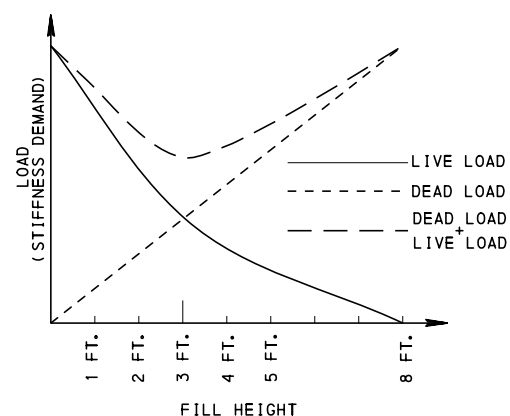

FOR SUBSTITUTION OF PIPES UNDER 3'-0" OF FILL OR LESS USE A LOWER HEIGHT OF FILL. FOR SUBSTITUTION OF PIPES OVER 3'-0" OF FILL OR GREATER, USE A HIGHER HEIGHT OF FILL.

COMMONWEALTH OF PENNSYLVANIA
DEPARTMENT OF TRANSPORTATION
BUREAU OF PROJECT DELIVERY

STANDARD
REINFORCED CONCRETE PIPES
DESIGN EXAMPLES/
RESPONSIBILITIES

RECOMMENDED APR. 29, 2016

Thomas P. Maiore
CHIEF BRIDGE ENGINEER

RECOMMENDED APR. 29, 2016

Brenda S. Thompson
DIRECTOR, BUR. OF PROJECT DELIVERY

SHEET 3 OF 10

BD-636M

TYPE A STANDARD INSTALLATION - STEEL AREAS (in. ² /ft.)														
Dia.	Wall Thick.	f' c (psi)	Required Fill/Cover Height							H > 50'				
			H < 1.5'	1.5' ≤ H < 2'	2' ≤ H < 3'	3' ≤ H < 7'	7' ≤ H < 10'	15'	20'		25'	30'	40'	50'
12"	2"	4000	0.09	*	*	*	*	*	*	*	*	0.14	**	**
		5000	*	*	*	*	*	*	*	*	*	*	0.18	**
12"	2 1/4"	4000	0.08	*	*	*	*	*	*	*	*	0.09	0.11	**
		6000	*	*	*	*	*	*	*	*	*	*	*	**
15"	2 1/4"	4000	0.12	*	*	0.08	*	*	*	0.10	0.12	0.22	**	**
		5000	0.08	*	*	0.08	*	*	*	0.08	0.09	0.12	0.19	**
18"	2 1/2"	4000	0.14	0.09	0.08	*	*	*	*	0.11	0.13	0.16	**	**
		5000	*	*	*	*	*	*	*	*	*	*	0.23	**
18"	3 1/4"	4000	0.14	0.08	0.07	*	*	*	*	0.08	0.10	0.12	0.18	**
		6000	0.22	0.12	0.08	*	*	*	*	0.10	0.13	0.17	0.22	**
21"	2 1/4"	4000	**	*	*	*	*	*	*	*	*	*	0.26	**
		6000	**	*	*	*	*	*	*	0.08	0.10	0.13	0.16	0.27
21"	3 1/2"	4000	**	0.10	0.07	0.08	0.10	0.13	0.16	0.27	**	**	**	**
		5000	0.22	*	*	*	*	*	*	*	*	*	*	*
24"	3"	4000	**	0.15	0.10	0.12	0.16	0.20	0.28	**	**	**	**	**
		5000	**	0.13	0.08	0.10	0.13	0.16	0.19	0.34	**	**	**	**
24"	3 3/4"	4000	0.22	*	*	*	*	*	*	*	*	*	*	**
		5000	**	0.17	0.12	0.10	0.10	0.14	0.19	0.24	**	**	**	**
27"	3 1/4"	4000	**	*	*	*	*	*	*	*	*	*	0.28	**
		6000	0.27	*	*	*	*	*	*	*	*	*	*	**
27"	4"	4000	**	0.15	0.10	0.09	0.09	0.12	0.15	0.19	0.23	**	**	**
		6000	0.27	*	*	*	*	*	*	*	*	*	*	**
30"	3 1/2"	4000	**	0.20	0.14	0.12	0.12	0.17	0.22	0.29	**	**	**	**
		5000	**	0.17	0.12	0.10	0.10	0.14	0.18	0.23	0.29	**	**	**
33"	3 3/4"	4000	**	0.22	0.17	0.17	0.17	0.22	0.25	**	**	**	**	**
		5000	**	*	*	*	*	*	0.31	0.42	**	**	**	**
33"	4 1/2"	4000	**	0.19	0.15	0.12	0.12	0.16	0.21	0.26	0.35	**	**	**
		5000	**	0.24	0.19	0.14	0.16	0.22	0.29	**	**	**	**	**
36"	4"	4000	**	0.24	0.19	0.14	0.16	0.22	0.29	**	**	**	**	**
		5000	**	*	*	*	*	*	0.35	**	**	**	**	**
36"	4 3/4"	4000	**	0.20	0.17	0.13	0.14	0.19	0.24	0.30	**	**	**	**
		5000	**	*	*	*	*	*	0.35	**	**	**	**	**

TYPE A STANDARD INSTALLATION - STEEL AREAS (in. ² /ft.)													
Dia.	Wall Thick.	f' c (psi)	Required Fill/Cover Height							H > 40'			
			H < 1.5'	1.5' ≤ H < 2'	2' ≤ H < 3'	3' ≤ H < 7'	7' ≤ H < 10'	15'	20'		25'	30'	40'
36"	4"	4000	0.19	0.18	0.14	0.11	0.12	0.16	0.21	0.28	0.39	**	**
		6000	0.13	0.12	0.09	0.07	0.07	0.08	0.11	0.14	0.17	**	**
36"	4 3/4"	4000	0.16	0.15	0.12	0.10	0.10	0.13	0.17	0.21	0.25	0.50	**
		6000	0.10	0.09	0.07	0.07	0.07	0.08	0.10	0.12	0.17	**	**
42"	4 1/2"	4000	0.20	0.19	0.17	0.17	0.17	0.20	0.25	0.36	0.49	**	**
		6000	0.13	0.12	0.10	0.07	0.07	0.10	0.13	0.17	0.21	**	**
42"	5 1/4"	4000	0.16	0.16	0.14	0.14	0.14	0.16	0.21	0.25	0.37	**	**
		6000	0.10	0.10	0.08	0.07	0.07	0.08	0.10	0.12	0.15	**	**
48"	5"	4000	0.18	0.20	0.19	0.19	0.23	0.31	0.45	0.62	**	**	**
		6000	0.11	0.13	0.12	0.12	0.16	0.20	0.24	**	**	**	**
48"	5 3/4"	4000	0.18	0.17	0.16	0.16	0.20	0.25	0.32	0.52	**	**	**
		6000	0.11	0.10	0.10	0.10	0.07	0.12	0.15	0.18	**	**	**
54"	5 1/2"	4000	0.21	0.21	0.20	0.20	0.26	0.38	0.55	**	**	**	**
		6000	0.14	0.13	0.12	0.12	0.14	0.18	0.23	**	**	**	**
54"	6 1/4"	4000	0.19	0.18	0.18	0.18	0.23	0.29	0.45	0.68	**	**	**
		6000	0.12	0.11	0.10	0.10	0.11	0.14	0.18	0.22	**	**	**

TYPE A STANDARD INSTALLATION - STEEL AREAS (in. ² /ft.)												
Dia.	Wall Thick.	f' c (psi)	Required Fill/Cover Height							H > 30'		
			H < 1.5'	1.5' ≤ H < 2'	2' ≤ H < 3'	3' ≤ H < 7'	7' ≤ H < 10'	15'	20'		25'	30'
60"	6"	4000	0.22	0.22	0.22	0.22	0.22	0.30	0.45	0.69	**	**
		6000	0.14	0.13	0.13	0.12	0.12	0.16	0.21	0.26	**	**
60"	6 1/4"	4000	0.20	0.19	0.19	0.20	0.26	0.33	0.59	**	**	
		6000	0.12	0.11	0.11	0.10	0.10	0.13	0.17	0.21	**	**
66"	6 1/2"	4000	0.24	0.23	0.25	0.35	0.53	**	**	**	**	
		6000	0.14	0.14	0.14	0.18	0.23	**	**	**	**	
66"	7 1/4"	4000	0.21	0.21	0.23	0.30	0.43	0.71	**	**		
		6000	0.12	0.12	0.11	0.15	0.19	0.24	**	**		
72"	7"	4000	0.25	0.25	0.24	0.26	0.29	0.40	0.65	**	**	
		6000	0.15	0.15	0.14	0.14	0.15	0.20	0.26	**	**	
72"	7 3/4"	4000	0.23	0.23	0.22	0.24	0.26	0.34	0.53	0.86	**	**
		6000	0.13	0.13	0.12	0.12	0.13	0.17	0.22	0.27	**	**
78"	7 1/2"	4000	0.26	0.26	0.26	0.29	0.32	0.47	0.78	**	**	
		6000	0.15	0.15	0.15	0.15	0.17	0.22	0.28	**	**	
78"	8 1/4"	4000	0.24	0.24	0.24	0.27	0.29	0.38	0.66	**	**	
		6000	0.14	0.13	0.13	0.13	0.14	0.19	0.24	**	**	
78"	8 3/4"	4000	0.24	0.24	0.24	0.27	0.29	0.38	0.66	**	**	
		6000	0.14	0.13	0.13	0.13	0.14	0.19	0.24	**	**	
78"	9"	4000	0.24	0.24	0.24	0.27	0.29	0.38	0.66	**	**	
		6000	0.14	0.13	0.13	0.13	0.14	0.19	0.24	**	**	
78"	9 1/4"	4000	0.24	0.24	0.24	0.27	0.29	0.38	0.66	**	**	
		6000	0.14	0.13	0.13	0.13	0.14	0.19	0.24	**	**	

TYPE A STANDARD INSTALLATION - STEEL AREAS (in. ² /ft.)											
Dia.	Wall Thick.	f' c (psi)	Required Fill/Cover Height							H > 25'	
			H < 1.5'	1.5' ≤ H < 2'	2' ≤ H < 3'	3' ≤ H < 7'	7' ≤ H < 10'	15'	20'		25'
84"	8"	4000	0.28	0.28	0.29	0.32	0.35	0.54	0.91	**	**
		6000	0.16	0.16	0.16	0.16	0.18	0.24	0.31	**	**
84"	8 3/4"	4000	0.26	0.26	0.27	0.30	0.33	0.43	0.79	**	**
		6000	0.14	0.14	0.14	0.15	0.16	0.21	0.27	**	**
90"	8 1/2"	4000	0.30	0.30	0.32	0.36	0.39	0.64	**	**	
		6000	0.17	0.17	0.17	0.19	0.20	0.27	**	**	
90"	9 1/4"	4000	0.28	0.28	0.30	0.33	0.36	0.52	0.94	**	**
		6000	0.15	0.15	0.15	0.17	0.18	0.23	0.30	**	**
96"	9"	4000	0.32	0.32	0.35	0.39	0.43	0.74	**	**	
		6000	0.18	0.17	0.18	0.20	0.22	0.29	**	**	
96"	9 3/4"	4000	0.30	0.30	0.33	0.37	0.40	0.62	**	**	
		6000	0.16	0.16	0.17	0.18	0.20	0.26	**	**	
102"	9 1/2"	4000	0.34	0.35	0.38	0.43	0.50	0.86	**	**	
		6000	0.18	0.18	0.20	0.22	0.24	0.31	**	**	
102"	10 1/4"	4000	0.32	0.33	0.36	0.40	0.44	0.75	**	**	
		6000	0.17	0.17	0.18	0.20	0.22	0.28	**	**	

TYPE A STANDARD INSTALLATION - STEEL AREAS (in. ² /ft.)											
Dia.	Wall Thick.	f' c (psi)	Required Fill/Cover Height							H > 20'	
			H < 1.5'	1.5' ≤ H < 2'	2' ≤ H < 3'	3' ≤ H < 7'	7' ≤ H < 10'	15'	20'		
108"	10"	4000	0.36	0.37	0.41	0.46	0.57	1.00	**	**	
		6000	0.20	0.19	0.21	0.24	0.26	0.34	**	**	
108"	10 3/4"	4000	0.35	0.35	0.39	0.44	0.48	0.89	**	**	
		6000	0.18	0.18	0.20	0.22	0.24	0.31	**	**	
114"	10 1/2"	4000	0.39	0.40	0.44	0.52	0.64	**	**		
		6000	0.20	0.21	0.23	0.26	0.28	**	**		
114"	11 1/4"	4000	0.37	0.38	0.42	0.48	0.53	1.03	**	**	
		6000	0.19	0.19	0.21	0.24	0.26	0.33	**	**	
120"	11"	4000	0.41	0.43	0.47	0.59	0.71	**	**		
		6000	0.21	0.22	0.24	0.28	0.30	**	**		
120"	11 3/4"	4000	0.40	0.40	0.45	0.52	0.61	1.18	**	**	
		6000	0.20	0.20	0.23	0.26	0.28	0.36	**	**	

TYPE A STANDARD INSTALLATION REQUIRED FILL/COVER HEIGHT (FT.) - PROOF TEST LOAD (lbs./LF/FT.OF DIAMETER)																																	
DIA. (in.)	1.0' ≤ H ≤ 1.5'	1.5' ≤ H ≤ 2'	2' ≤ H ≤ 3'	3' ≤ H ≤ 7'	7' ≤ H ≤ 10'	10' ≤ H ≤ 15'	15' ≤ H ≤ 20'	20' ≤ H ≤ 25'	25' ≤ H ≤ 30'	30' ≤ H ≤ 40'	40' ≤ H ≤ 50'	50' ≤ H ≤ 60'	60' ≤ H ≤ 70'	70' ≤ H ≤ 80'	80' ≤ H ≤ 90'	90' ≤ H ≤ 100'	DIA. (in.)	1.0' ≤ H ≤ 1.5'	1.5' ≤ H ≤ 2'	2' ≤ H ≤ 3'	3' ≤ H ≤ 7'	7' ≤ H ≤ 10'	10' ≤ H ≤ 15'	15' ≤ H ≤ 20'	20' ≤ H ≤ 25'	25' ≤ H ≤ 30'	30' ≤ H ≤ 40'	40' ≤ H ≤ 50'	50' ≤ H ≤ 60'	60' ≤ H ≤ 70'	70' ≤ H ≤ 80'	80' ≤ H ≤ 90'	90' ≤ H ≤ 100'
12	1720	1237	912	752	911	1271	1667	2066	2470	3282	4097	4913	5730	6548	7366	8183	60	601	810	601	663	857	1222	1605	1992	2383	3168	3956	4745	5534	6324	7114	7904
15	1547	1132	901	713	897	1244	1625	2015	2408	3200	3994	4790	5587	6384	7181	7979	66	555	814	657	698	850	1219	1600	1987	2377	3160	3946	4733	5520	6308	7096	7884
18	1412	1049	845	698	871	1222	1597	1980	2367	3145	3926	4709	5492	6275	7059	7842	72	490	774	631	687	870	1245	1636	2032	2431	3232	4036	4841	5646	6452	7258	8064
21	1303	980	798	686	858	1207	1577	1955	2337	3106	3877	4650	5423	6197	6971	7745	78	435	736	606	663	867	1243	1632	2028	2426	3226	4029	4832	5636	6441	7245	8049
24	1215	928	766	703	886	1250	1635	2028	2425	3223	4023	4825	5628	6431	7234	8037	84	391	699	582	660	860	1240	1630	2025	2422	3221	4023	4825	5628	6431	7234	8037
27	1386	1056	732	695	878	1240	1623	2013	2406	3199	3994	4790	5586	6383	7180	7978	90	355	633	590	656	861	1238	1627	2022	2419	3217	4017	4818	5620	6422	7224	8026
30	1303	1003	701	688	872	1232	1613	2001	2392	3179	3970	4761	5553	6345	7137	7930	96	324	578	556	653	859	1236	1625	2019	2416	3213	4013	4813	5614	6415	7216	8017
33	1230	955	674	683	866	1226	1604	1991	2380	3164	3950	4738	5526	6314	7102	7891	102	339	606	516	650	857	1234	1623	2017	2413	3210	4008	4808	5608	6408	7208	8009
36	1094	915	654	691	881	1249	1636	2030	2428	3227	4030	4833	5637	6441	7246	8050	108	313	559	482	647	855	1232	1621	2015	2411	3207	4005	4803	5603	6402	7202	8001
42	972	939	657	682	873	1240	1625	2017	2412	3206	4003	4802	5600	6399	7199	7998	114	291	518	475	645	853	1231	1619	2013	2409	3204	4001	4799	5598	6397	7196	7995
48	793	871	618	675	867	1233	1617	2007	2400	3191	3984	4778	5573	6368	7163	7959	120	272	483	448	642	851	1229	1618	2011	2407	3202	3998	4796	5594	6392	7190	7989
54	705	863	633	669	861	1228	1610	1999	2391	3178	3968	4760	5552	6344	7136	7928	NOTE: THESE PROOF LOADS INCLUDE A FACTOR OF SAFETY OF 1.43 FOR FIELD CRACK CONTROL.																

LEGEND
 = FOR INFORMATION ONLY. PROOF LOAD TEST MUST BE PERFORMED TO THE MAXIMUM PROOF TEST LOAD FOR THE RANGE OF ITEM NUMBER.

PROOF TEST LOAD TABLE FOR CIRCULAR PIPES - TYPE A STANDARD INSTALLATION

NOTE : PROOF LOADS ARE AN INDICATION OF CRACK CONTROLS AND NOT NECESSARILY STRENGTH CONTROL. ACTUAL STRUCTURAL DESIGN (CONCRETE STRENGTH, AREA OF STEEL AND WALL THICKNESS) IS BASED UPON FLEXURE, CRACKING, OR SHEAR - WHICHEVER GOVERNS. FOR SUBSTITUTION OF PIPES RELY UPON THE MAXIMUM VS. MINIMUM FILL HEIGHT STAMP. DO NOT USE THE PROOF LOAD FOR SUBSTITUTION PURPOSES. SEE FIGURE "FLEXURE - SHEAR - CRACK CONTROL" AND EXAMPLE ON SHEET 2.

NOTE:
 THESE PROOF LOADS INCLUDE A FACTOR OF SAFETY OF 1.43 FOR FIELD CRACK CONTROL.
 USE PAIDD PROGRAM TO DETERMINE PROOF LOAD VALUES FOR FILL HEIGHTS GREATER THAN 100' -0".

COMMONWEALTH OF PENNSYLVANIA
 DEPARTMENT OF TRANSPORTATION
 BUREAU OF PROJECT DELIVERY

STANDARD
 REINFORCED CONCRETE PIPES
 DESIGN TABLES

RECOMMENDED APR. 29, 2016 <i>Thomas P. Maiore</i> CHIEF BRIDGE ENGINEER	RECOMMENDED APR. 29, 2016 <i>Brenda S. Thompson</i> DIRECTOR, BUR. OF PROJECT DELIVERY	SHEET 5 OF 10 BD-636M
---	--	---------------------------------

TYPE B STANDARD INSTALLATION - STEEL AREAS (in. ² /ft.)															
Dia.	Wall Thick.	f' c (psi)	Required Fill/Cover Height												
			H ≤ 1.5'	1.5' ≤ H ≤ 2'	2' ≤ H ≤ 3'	3' ≤ H ≤ 7'	7' ≤ H ≤ 10'	15'	20'	25'	30'	40'	50'	H > 50'	
12"	2"	4000	0.09	*	*	0.08	*	*	*	*	*	*	0.12	**	**
		5000	*	*	*	*	*	*	*	*	*	*	0.16	**	**
12"	2 3/4"	4000	0.08	*	*	0.08	*	*	*	*	*	*	0.08	*	**
15"	2 1/4"	4000	0.11	*	*	0.08	*	*	*	0.09	0.11	0.19	**	**	**
		6000	*	*	*	*	*	*	*	*	*	*	0.19	**	**
15"	3"	4000	0.08	*	*	0.07	*	*	*	0.07	0.09	0.12	0.16	**	**
18"	2 1/2"	4000	0.13	*	*	0.08	*	*	*	0.10	0.12	0.15	**	**	**
		5000	*	*	*	*	*	*	*	*	*	*	0.21	**	**
18"	3 1/4"	4000	0.12	*	*	0.07	*	*	*	0.08	0.10	0.11	0.16	**	**
21"	2 3/4"	4000	0.17	0.11	0.07	0.07	0.09	0.12	0.16	0.19	**	**	**	**	**
21"	3 1/2"	4000	0.16	0.07	0.07	0.07	0.08	0.10	0.12	0.15	0.23	**	**	**	**
24"	3"	4000	0.22	0.14	0.10	0.10	0.11	0.15	0.19	0.24	**	**	**	**	**
24"	3 3/4"	4000	0.22	0.12	0.08	0.08	0.09	0.12	0.15	0.18	0.30	**	**	**	**
27"	3 1/4"	4000	**	0.16	0.11	0.10	0.10	0.13	0.18	0.22	0.30	**	**	**	**
		5000	0.26	*	*	*	*	*	*	*	*	*	**	**	**
27"	4"	4000	**	0.14	0.10	0.08	0.08	0.11	0.14	0.18	0.22	**	**	**	**
		5000	0.25	*	*	*	*	*	*	*	*	*	**	**	**
30"	3 1/2"	4000	**	0.18	0.13	0.13	0.16	0.21	0.26	**	**	**	**	**	**
		5000	**	*	*	*	*	*	*	*	*	*	**	**	**
		6000	0.29	*	*	*	*	*	*	*	*	*	**	**	**
30"	4 1/4"	4000	**	0.16	0.12	0.12	0.13	0.17	0.21	0.25	**	**	**	**	**
		6000	0.27	*	*	*	*	*	*	*	*	*	**	**	**
33"	3 3/4"	4000	**	0.21	0.16	0.16	0.18	0.24	0.31	**	**	**	**	**	**
		5000	**	*	*	*	*	*	*	0.39	**	**	**	**	**
33"	4 1/2"	4000	**	0.18	0.14	0.14	0.15	0.20	0.24	0.30	**	**	**	**	**
36"	4"	4000	**	0.22	0.18	0.13	0.15	0.21	0.27	0.38	**	**	**	**	**
		5000	**	*	*	*	*	*	*	*	0.47	**	**	**	**
36"	4 3/4"	4000	**	0.19	0.16	0.12	0.13	0.18	0.23	0.28	**	**	**	**	**
		5000	**	*	*	*	*	*	*	*	0.32	**	**	**	**
		6000	**	*	*	*	*	*	*	*	0.46	**	**	**	**
36"	4"	4000	0.18	0.17	0.09	0.11	0.11	0.15	0.20	0.26	0.36	**	**	**	**
		5000	0.12	0.11	0.07	0.07	0.07	0.08	0.10	0.13	0.16	**	**	**	**
		6000	*	*	*	*	*	*	*	*	*	0.53	**	**	**
		5000	*	*	*	*	*	*	*	*	*	0.21	**	**	**
36"	4 3/4"	4000	0.15	0.14	0.11	0.09	0.09	0.13	0.16	0.20	0.23	0.43	**	**	**
		5000	0.09	0.09	0.07	0.07	0.07	0.07	0.07	0.09	0.11	0.15	**	**	**
42"	4 1/2"	4000	0.19	0.18	0.16	0.14	0.14	0.18	0.24	0.34	0.46	**	**	**	**
		5000	0.12	0.12	0.09	0.08	0.08	0.10	0.13	0.16	0.19	**	**	**	**
		6000	*	*	*	*	*	*	*	*	*	0.62	**	**	**
		5000	*	*	*	*	*	*	*	*	*	0.25	**	**	**
42"	5 1/4"	4000	0.16	0.15	0.13	0.12	0.12	0.15	0.20	0.24	0.30	0.61	**	**	**
		5000	0.10	0.09	0.08	0.07	0.07	0.07	0.09	0.12	0.14	0.20	**	**	**
48"	5"	4000	0.19	0.19	0.18	0.16	0.16	0.21	0.29	0.42	0.56	**	**	**	**
		5000	0.12	0.12	0.11	0.09	0.09	0.11	0.15	0.19	0.23	**	**	**	**
		6000	*	*	*	*	*	*	*	*	*	0.74	**	**	**
		5000	*	*	*	*	*	*	*	*	*	0.29	**	**	**
48"	5 3/4"	4000	0.17	0.16	0.15	0.14	0.14	0.18	0.23	0.28	0.44	**	**	**	**
		5000	0.10	0.10	0.09	0.07	0.07	0.09	0.11	0.14	0.17	**	**	**	**
		6000	*	*	*	*	*	*	*	*	*	0.62	**	**	**
		5000	*	*	*	*	*	*	*	*	*	0.23	**	**	**

TYPE B STANDARD INSTALLATION REQUIRED FILL/COVER HEIGHT FT. / PROOF TEST LOAD (lbs. /LF/FT. OF DIAMETER)																					
DIA. (In.)	1.0 ≤ H ≤ 1.5'	1.5 ≤ H ≤ 2'	2' ≤ H ≤ 3'	3' ≤ H ≤ 7'	7' ≤ H ≤ 10'	10' ≤ H ≤ 15'	15' ≤ H ≤ 20'	20' ≤ H ≤ 25'	25' ≤ H ≤ 30'	30' ≤ H ≤ 40'	40' ≤ H ≤ 50'	50' ≤ H ≤ 60'	60' ≤ H ≤ 70'	70' ≤ H ≤ 80'	80' ≤ H ≤ 90'	90' ≤ H ≤ 100'					
12	1634	1175	923	714	866	1213	1564	1963	2346	3118	3892	4668	5444	6220	6997	7774					
15	1470	1075	856	677	843	1182	1544	1914	2287	3040	3795	4451	5308	6065	6822	7580					
18	1342	996	802	663	827	1161	1517	1881	2248	2988	3730	4473	5217	5961	6706	7450					
21	1238	931	758	652	816	1147	1498	1857	2220	2950	3683	4418	5152	5887	6622	7358					
24	1154	881	728	668	841	1187	1553	1927	2303	3061	3822	4584	5347	6109	6872	7635					
27	1317	1004	695	660	834	1178	1541	1912	2286	3039	3794	4550	5307	6064	6821	7579					
30	1237	952	666	654	828	1171	1532	1901	2272	3020	3771	4523	5275	6028	6781	7534					
33	1168	907	640	648	823	1164	1524	1891	2261	3006	3753	4501	5249	5998	6747	7496					
36	1039	870	621	656	837	1186	1554	1929	2306	3066	3828	4591	5355	6119	6883	7648					
42	924	892	624	648	829	1178	1543	1916	2291	3046	3803	4562	5320	6079	6839	7598					
48	754	827	587	641	823	1171	1536	1906	2280	3031	3785	4539	5294	6050	6805	7561					

NOTE: THESE PROOF LOADS INCLUDE A FACTOR OF SAFETY OF 1.43 FOR FIELD CRACK CONTROL.

NOTE :

PROOF LOADS ARE AN INDICATION OF CRACK CONTROLS AND NOT NECESSARILY STRENGTH CONTROL. ACTUAL STRUCTURAL DESIGN (CONCRETE STRENGTH, AREA OF STEEL AND WALL THICKNESS) IS BASED UPON FLEXURE, CRACKING, OR SHEAR - WHICHEVER GOVERNS. FOR SUBSTITUTION OF PIPES RELY UPON THE MAXIMUM VS. MINIMUM FILL HEIGHT STAMP. DO NOT USE THE PROOF LOAD FOR SUBSTITUTION PURPOSES. SEE FIGURE "FLEXURE - SHEAR - CRACK CONTROL" AND EXAMPLE ON SHEET 2.

LEGEND

 = FOR INFORMATION ONLY. PROOF LOAD TEST MUST BE PERFORMED TO THE MAXIMUM PROOF TEST LOAD FOR THE RANGE OF ITEM NUMBER.

NOTES:

- * INDICATES SAME STEEL AREA AS SHOWN FOR THE LESSER CONCRETE STRENGTH.
- ** INDICATES A SPECIAL DESIGN IS REQUIRED. USE PAIDD SOFTWARE.
- ELLIPTICAL REINFORCING IS NOT ALLOWED, EXCEPT FOR QUADRANT REINFORCEMENT AND FOR REINFORCEMENT OF ELLIPTICAL PIPE.
- FOR DOUBLE CIRCULAR STEEL REINFORCED PIPE, TWO AREAS ARE SHOWN. THE GREATER AREA IS FOR THE INNER CAGE STEEL AND LESSER AREA IS FOR OUTER CAGE STEEL.
- FOR PIPE SIZES GREATER THAN 48" DIAMETER, USE TYPE A STANDARD INSTALLATION DESIGN TABLES.
- H = DESIGN FILL HEIGHT, FT.
- SUBSTITUTION OF PIPES UNDER FILLS OF 3'-0" OR LESS IS PERMITTED ONLY WITH DESIGNER APPROVAL.
- USE PAIDD SOFTWARE ONLY FOR PIPE DESIGNS NOT PROVIDED BY BD-636M.
- STEEL AREAS SPECIFIED IN THE FILL HEIGHT / STEEL AREA TABLES ARE TO BE ACHIEVED USING ONE LAYER OF REINFORCEMENT FOR EACH CAGE. TWO LAYERS MAY BE SUBSTITUTED FOR ONE LAYER PROVIDED THE SUM OF THE STEEL AREAS OF THE 2 LAYERS IS EQUAL TO THE AREA OF STEEL FOR THE SINGLE LAYER CAGE. WHEN SUBSTITUTING, SPACING OF REINFORCEMENT IS TO REMAIN THE SAME. DESIGNING FOR 2 LAYERS OF REINFORCEMENT AND PROVIDING ONE LAYER OF REINFORCEMENT OF EQUIVALENT AREA IS NOT PERMITTED.

DESIGN TABLES AND PROOF TEST LOAD TABLE FOR CIRCULAR PIPES - TYPE B STANDARD INSTALLATION

COMMONWEALTH OF PENNSYLVANIA
DEPARTMENT OF TRANSPORTATION
BUREAU OF PROJECT DELIVERY

STANDARD REINFORCED CONCRETE PIPES DESIGN TABLES

RECOMMENDED APR. 29, 2016 <i>Thomas P. Maiore</i> CHIEF BRIDGE ENGINEER	RECOMMENDED APR. 29, 2016 <i>Brenda S. Thompson</i> DIRECTOR, BUR. OF PROJECT DELIVERY	SHEET 6 OF 10 BD-636M
---	--	---------------------------------

TYPE A SHORING/TRENCH BOX - STEEL AREAS (in. ² /ft.)								
Dia.	Wall Thick.	f' c (psi)	Required Fill/Cover Height					
			H < 1.5'	1.5' ≤ H < 2'	2' ≤ H < 3'	3' ≤ H < 7'	7' ≤ H < 10'	15'
12"	2"	4000					0.08	
12"	2 3/4"	4000					0.08	
15"	2 1/4"	4000				0.09	0.08	
15"	3"	4000				0.09	0.08	
18"	2 1/2"	4000				0.12	0.09	0.10
18"	3 1/4"	4000				0.11	0.08	0.09
21"	2 3/4"	4000				0.14	0.11	0.10
21"	3 1/2"	4000				0.14	0.10	0.11
24"	3"	4000				0.18	0.14	0.12
24"	3 3/4"	4000				0.17	0.12	0.09
27"	3 1/4"	4000				0.20	0.16	0.14
27"	4"	4000				0.17	0.14	0.12
30"	3 1/2"	4000	**	0.33	0.24	0.19	0.16	0.20
30"	4 1/4"	4000	**	0.26	0.20	0.16	0.20	0.20
33"	3 3/4"	4000	**	0.36	0.27	0.21	0.18	0.23
33"	4 1/2"	4000	**	0.30	0.23	0.18	0.16	0.21
36"	4"	4000	**	0.36	0.31	0.22	0.21	0.31
36"	4 3/4"	4000	**	0.31	0.26	0.20	0.18	0.26
36"	4"	4000	**	0.29	0.22	0.18	0.16	0.19
			**	0.16	0.12	0.09	0.07	0.09
36"	4 3/4"	4000	**	0.23	0.18	0.15	0.13	0.18
			**	0.12	0.09	0.07	0.07	0.07
42"	4 1/2"	4000	**	0.30	0.26	0.23	0.23	0.35
			**	0.16	0.13	0.12	0.12	0.14
42"	5 1/4"	4000	**	0.24	0.22	0.20	0.20	0.25
			**	0.13	0.11	0.10	0.10	0.11

TYPE A SHORING/TRENCH BOX - STEEL AREAS (in. ² /ft.)								
Dia.	Wall Thick.	f' c (psi)	Required Fill/Cover Height					
			H < 1.5'	1.5' ≤ H < 2'	2' ≤ H < 3'	3' ≤ H < 7'	7' ≤ H < 10'	15'
48"	5"	4000	**	0.30	0.30	0.26	0.27	0.44
			**	0.16	0.16	0.13	0.13	0.16
48"	5 3/4"	4000	**	0.26	0.26	0.23	0.23	0.30
			**	0.14	0.14	0.11	0.11	0.14
54"	5 1/2"	4000	**	0.32	0.31	0.30	0.34	0.53
			**	0.17	0.16	0.15	0.15	0.18
54"	6 1/4"	4000	**	0.27	0.27	0.26	0.27	0.38
			**	0.14	0.13	0.13	0.12	0.15
60"	6"	4000	**	0.33	0.33	0.33	0.42	0.62
			**	0.18	0.17	0.17	0.17	0.20
60"	6 3/4"	4000	**	0.29	0.29	0.30	0.31	0.48
			**	0.15	0.14	0.15	0.14	0.18
66"	6 1/2"	4000	**	0.35	0.35	0.38	0.50	0.74
			**	0.18	0.18	0.18	0.19	0.23
66"	7 1/4"	4000	**	0.31	0.31	0.33	0.37	0.60
			**	0.16	0.15	0.16	0.16	0.20
72"	7"	4000	**	0.37	0.39	0.43	0.58	**
			**	0.19	0.19	0.18	0.21	**
		5000	**	*	*	*	*	0.76
			**	*	*	*	*	0.26
72"	7 3/4"	4000	**	0.34	0.35	0.36	0.45	0.75
			**	0.17	0.16	0.17	0.19	0.23
78"	7 1/2"	4000	**	0.39	0.39	0.51	0.67	**
			**	0.20	0.20	0.20	0.23	**
		5000	**	*	*	*	*	0.86
			**	*	*	*	*	0.28
78"	8 1/4"	4000	**	0.36	0.39	0.39	0.53	0.91
			**	0.18	0.18	0.18	0.21	0.25

TYPE A SHORING/TRENCH BOX - STEEL AREAS (in. ² /ft.)								
Dia.	Wall Thick.	f' c (psi)	Required Fill/Cover Height					
			H < 1.5'	1.5' ≤ H < 2'	2' ≤ H < 3'	3' ≤ H < 7'	7' ≤ H < 10'	15'
84"	8"	4000	**	0.42	0.42	0.59	0.78	**
			**	0.21	0.21	0.22	0.26	**
		6000	**	*	*	*	*	0.90
			**	*	*	*	*	0.31
84"	8 3/4"	4000	**	0.39	0.39	0.47	0.64	**
			**	0.19	0.19	0.20	0.23	**
		5000	**	*	*	*	*	0.82
			**	*	*	*	*	0.28
90"	8 1/2"	4000	**	0.45	0.45	0.68	0.92	**
			**	0.22	0.22	0.25	0.28	**
		6000	**	*	*	*	*	1.01
			**	*	*	*	*	0.33
90"	9 1/4"	4000	**	0.41	0.41	0.55	0.93	**
			**	0.20	0.20	0.23	0.28	**
		5000	**	*	*	*	*	0.94
			**	*	*	*	*	0.30
96"	9"	4000	**	0.50	0.48	0.76	**	**
			**	0.23	0.23	0.27	**	**
		5000	**	*	*	*	*	0.88
			**	*	*	*	*	0.30
96"	9 3/4"	4000	**	0.44	0.44	0.64	0.93	**
			**	0.21	0.21	0.25	0.28	**
		6000	**	*	*	*	*	0.95
			**	*	*	*	*	0.33
102"	9 1/2"	4000	**	0.56	0.52	0.85	**	**
			**	0.25	0.25	0.30	**	**
		5000	**	*	*	*	*	0.97
			**	*	*	*	*	0.33
102"	10 1/4"	4000	**	0.47	0.48	0.73	**	**
			**	0.23	0.23	0.27	**	**
		5000	**	*	*	*	*	0.83
			**	*	*	*	*	0.30

TYPE A S/T BOX - STEEL AREAS (in. ² /ft.)							
Dia.	Wall Thick.	f' c (psi)	Required Fill/Cover Height				
			H < 1.5'	1.5' ≤ H < 2'	2' ≤ H < 3'	3' ≤ H < 7'	7' ≤ H < 10'
108"	10"	4000	**	0.62	0.58	**	**
			**	0.26	0.26	*	*
		6000	**	*	*	*	1.00
			**	*	*	*	0.35
108"	10 3/4"	4000	**	0.51	0.51	0.86	**
			**	0.24	0.24	0.30	**
		5000	**	*	*	*	0.93
			**	*	*	*	0.33
114"	10 1/2"	4000	**	0.68	0.65	**	**
			**	0.28	0.28	*	*
		6000	**	0.28	0.28	*	1.11
			**	*	*	*	0.38
114"	11 1/4"	4000	**	0.58	0.55	0.73	**
			**	0.26	0.26	0.29	**
		5000	**	*	*	*	1.06
			**	*	*	*	0.35
120"	11"	4000	**	0.75	**	**	**
			**	0.29	**	**	**
		5000	**	*	0.72	*	**
			**	*	0.30	*	**
		6000	**	*	*	*	1.22
			**	*	*	*	0.40
120"	11 3/4"	4000	**	0.64	0.62	0.82	**
			**	0.28	0.28	0.31	**
		6000	**	*	*	*	1.07
			**	*	*	*	0.38

TYPE A SHORING/TRENCH BOX INSTALLATION REQUIRED FILL/COVER HEIGHT (FT.) / PROOF TEST LOAD (lbs/LF/FT. OF DIAMETER)								
DIA. (in.)	1.5' ≤ H < 2'	2' ≤ H < 3'	3' ≤ H < 7'	7' ≤ H < 10'	10' ≤ H < 15'	15' ≤ H < 20'	20' ≤ H < 25'	
12	1762	1496	1196	1295	1818	2376	2945	
15	1621	1393	1135	1260	1772	2318	2872	
18	1509	1313	1087	1237	1741	2276	2822	
21	1418	1247	1048	1220	1719	2247	2787	
24	1341	1192	1015	1207	1702	2226	2761	
27	1274	1143	986	1196	1688	2209	2740	
30	1216	1101	961	1187	1678	2195	2723	
33	1165	1063	938	1180	1669	2184	2710	
36	1119	1029	924	1174	1661	2175	2698	
42	1092	985	1125	1467	2105	2767	3439	
48	1023	936	1114	1457	2093	2753	3422	
54	1015	895	1104	1449	2084	2742	3409	
60	961	858	1096	1442	2077	2733	3398	
66	965	858	1089	1436	2070	2726	3389	
72	922	829	1082	1431	2065	2719	3382	
78	882	802	1076	1426	2061	2714	3375	
84	847	778	1071	1422	2057	2709	3370	
90	786	786	1066	1418	2053	2705	3365	
96	752	752	1061	1415	2050	2702	3361	
102	753	712	1057	1412	2047	2699	3357	
108	705	678	1053	1409	2044	2696	3354	
114	671	671	1049	1406	2042	2693	3351	
120	643	643	1046	1404	2040	2691	3348	

NOTE: THESE PROOF LOADS INCLUDE A 1.43 SAFETY FACTOR FOR FIELD CRACK CONTROL.

NOTE: PROOF LOADS ARE AN INDICATION OF CRACK CONTROLS AND NOT NECESSARILY STRENGTH CONTROL. ACTUAL STRUCTURAL DESIGN (CONCRETE STRENGTH, AREA OF STEEL AND WALL THICKNESS) IS BASED UPON FLEXURE, CRACKING, OR SHEAR - WHICHEVER GOVERNS. FOR SUBSTITUTION OF PIPES RELY UPON THE MAXIMUM VS. MINIMUM FILL HEIGHT STAMP. DO NOT USE THE PROOF LOAD FOR SUBSTITUTION PURPOSES. SEE FIGURE "FLEXURE - SHEAR - CRACK CONTROL" AND EXAMPLE ON SHEET 2.

DESIGN TABLES AND PROOF TEST LOAD TABLE FOR CIRCULAR PIPES - TYPE A SHORING/TRENCH BOX INSTALLATION

NOTES:

- * INDICATES SAME STEEL AREA AS SHOWN FOR THE LESSER CONCRETE STRENGTH.
- ** INDICATES A SPECIAL DESIGN IS REQUIRED. USE PAIDD SOFTWARE.
- ELLIPTICAL REINFORCING IS NOT ALLOWED, EXCEPT FOR QUADRANT REINFORCEMENT AND REINFORCEMENT OF ELLIPTICAL PIPE.
- FOR DOUBLE CIRCULAR STEEL REINFORCED PIPE, TWO AREAS ARE SHOWN. THE GREATER AREA IS FOR THE INNER CAGE STEEL AND LESSER AREA IS FOR OUTER CAGE STEEL.
- FOR PIPE DIAMETERS GREATER THAN 48", USE TYPE A SHORING/TRENCH BOX DESIGN TABLES.
- FOR FILL HEIGHTS GREATER THAN INDICATED, USE THE PAIDD PROGRAM.
- H = DESIGN FILL HEIGHT, FT.
- SUBSTITUTION OF PIPES UNDER FILLS OF 3'-0" OR LESS IS PERMITTED ONLY WITH DESIGNER APPROVAL.
- USE PAIDD SOFTWARE ONLY FOR PIPE DESIGNS NOT PROVIDED BY BD-636M.
- STEEL AREAS SPECIFIED IN THE FILL HEIGHT / STEEL AREA TABLES ARE TO BE ACHIEVED USING ONE LAYER OF REINFORCEMENT FOR EACH CAGE. TWO LAYERS MAY BE SUBSTITUTED FOR ONE LAYER PROVIDED THE SUM OF THE STEEL AREAS OF THE 2 LAYERS IS EQUAL TO THE AREA OF STEEL FOR THE SINGLE LAYER CAGE. WHEN SUBSTITUTING, SPACING OF REINFORCEMENT IS TO REMAIN THE SAME. DESIGNING FOR 2 LAYERS OF REINFORCEMENT AND PROVIDING ONE LAYER OF REINFORCEMENT OF EQUIVALENT AREA IS NOT PERMITTED.
- *** INDICATES A SHEAR CONTROL HAS BEEN REACHED, USE PAIDD SOFTWARE FOR SPECIAL DESIGN.

TYPE B SHORING/TRENCH BOX - STEEL AREAS (in. ² /ft.)								
Dia.	Wall Thick.	f' c (psi)	Required Fill/Cover Height					
			H < 1.5'	1.5' ≤ H < 2'	2' ≤ H < 3'	3' ≤ H < 7'	7' ≤ H < 10'	15'
12"	2"	4000					0.08	
12"	2 3/4"	4000					0.07	
15"	2 1/4"	4000					0.08	
15"	3"	4000					0.07	
18"	2 1/2"	4000				0.11	0.09	0.07
18"	3 1/4"	4000				0.09	0.07	0.07
21"	2 3/4"	4000				0.13	0.11	0.09
21"	3 1/2"	4000				0.11	0.09	0.09
24"	3"	4000				0.16	0.13	0.11
24"	3 3/4"	4000				0.13	0.11	0.09
27"	3 1/4"	4000	NO SHORING	NO SHORING		0.19	0.15	0.13
27"	4"	4000	NO SHORING	NO SHORING		0.16	0.13	0.11
30"	3 1/2"	4000	**	0.29	0.22	0.17	0.15	0.18
30"	4 1/4"	4000	**	0.25	0.18	0.15	0.13	0.16
33"	3 3/4"	4000	**	0.33	0.25	0.20	0.17	0.21
33"	4 1/2"	4000	**	0.28	0.21	0.17	0.15	0.18

TYPE B SHORING/TRENCH BOX - STEEL AREAS (in. ² /ft.)							
Dia.	Wall Thick.	f' c (psi)	Required Fill/Cover Height				
			H < 1.5'	1.5' ≤ H < 2'	2' ≤ H < 3'	3' ≤ H < 7'	7' ≤ H < 10'
36"	4"	4000	**				

TYPE A STANDARD INSTALLATION HORIZONTAL ELLIPTICAL PIPE H<1.5 ft				
Equi- valent Round	Rise /Span (in.)	Wall Thick. (in.)	f' c (psi)	Steel Area (in. ² /ft.)
18"	14x23	2 3/4"	4000	**
			5000	0.20
24"	19x30	3 1/4"	4000	**
27"	22x34	3 1/2"	4000	**
			5000	**
			6000	**
30"	24x38	3 3/4"	4000	0.22
				0.22
33"	27x42	3 3/4"	4000	0.25
				0.25
36"	29x45	4 1/2"	4000	0.21
				0.21
42"	34x53	5"	4000	0.23
				0.23
48"	38x60	5 1/2"	4000	0.24
				0.24
54"	43x68	6"	4000	0.26
				0.26
60"	48x76	6 1/2"	4000	0.28
				0.28
66"	53x83	7"	4000	0.30
				0.30
72"	58x91	7 1/2"	4000	0.33
				0.33
78"	63x98	8"	4000	0.36
				0.36
84"	68x106	8 1/2"	4000	0.44
				0.44
90"	72x113	9"	4000	0.50
				0.50
96"	77x121	9 1/2"	4000	0.60
				0.60
102"	82x128	9 3/4"	4000	0.71
				0.71
108"	87x136	10"	4000	0.86
				0.86
114"	92x143	10 1/2"	4000	0.95
				0.95
120"	97x151	11"	4000	1.08
				1.08

TYPE B STANDARD INSTALLATION HORIZONTAL ELLIPTICAL PIPE H<1.5 ft.				
Equi- valent Round	Rise /Span (in.)	Wall Thick. (in.)	f' c (psi)	Steel Area (in. ² /ft.)
18"	14x23	2 3/4"	4000	0.20
24"	19x30	3 1/4"	4000	**
			5000	**
			6000	0.29
27"	22x34	3 1/2"	4000	**
			5000	**
			6000	**
30"	24x38	3 3/4"	4000	0.21
				0.21
33"	27x42	3 3/4"	4000	0.23
				0.23
36"	29x45	4 1/2"	4000	0.20
				0.20
42"	34x53	5"	4000	0.22
				0.22
48"	38x60	5 1/2"	4000	0.23
				0.23
54"	43x68	6"	4000	0.25
				0.25
60"	48x76	6 1/2"	4000	0.27
				0.27
66"	53x83	7"	4000	0.29
				0.29
72"	58x91	7 1/2"	4000	0.32
				0.32
78"	63x98	8"	4000	0.34
				0.34
84"	68x106	8 1/2"	4000	0.42
				0.42
90"	72x113	9"	4000	0.47
				0.47
96"	77x121	9 1/2"	4000	0.56
				0.56
102"	82x128	9 3/4"	4000	0.71
				0.71
108"	87x136	10"	4000	0.82
				0.82
114"	92x143	10 1/2"	4000	0.90
				0.90
120"	97x151	11"	4000	1.02
				1.02

NOTES:

- 1) * INDICATES SAME STEEL AREA AS SHOWN FOR THE LESSER CONCRETE STRENGTH.
- 2) ** INDICATES A SPECIAL DESIGN IS REQUIRED. USE PAIDD SOFTWARE.
- 3) ELLIPTICAL REINFORCING IS NOT ALLOWED, EXCEPT FOR QUADRANT REINFORCEMENT AND REINFORCEMENT OF ELLIPTICAL PIPE.
- 4) FOR DOUBLE CIRCULAR STEEL REINFORCED PIPE, TWO AREAS ARE SHOWN. THE GREATER AREA IS FOR THE INNER CAGE STEEL AND LESSER AREA IS FOR OUTER CAGE STEEL.
- 5) H = DESIGN FILL HEIGHT, FT.
- 6) SUBSTITUTION OF PIPES UNDER FILLS OF 3'-0" OR LESS IS PERMITTED ONLY WITH DESIGNER APPROVAL.
- 7) FOR DESIGN OF A TYPE A STANDARD ELLIPTICAL PIPE FOLLOW THESE STEPS:
 - (a) SELECT THE LARGER DIMENSION OF SPAN OR RISE FROM ELLIPTICAL PIPE SIZES SHOWN IN THE TYPE A SHORING/TRENCH BOX TABLE FOR ELLIPTICAL PIPES. I.E. RISE DIMENSION FOR VERTICAL ELLIPTICAL SPAN DIMENSION FOR HORIZONTAL ELLIPTICAL
 - (b) GO TO TYPE A STANDARD INSTALLATION TABLES FOR CIRCULAR PIPES.
 - (c) USE THE RISE DIMENSION FOR VERTICAL ELLIPTICAL DESIGNS OR THE SPAN DIMENSION FOR THE HORIZONTAL ELLIPTICAL DESIGNS AS THE DIAMETER IN THE TYPE A STANDARD INSTALLATION TABLES FOR CIRCULAR PIPE. [IF THE SELECTED DIAMETER IS NOT AVAILABLE IN THE TYPE A STANDARD INSTALLATION TABLES FOR CIRCULAR PIPE, USE THE NEXT LARGER AVAILABLE DIAMETER IN THE TYPE A STANDARD INSTALLATION TABLES FOR CIRCULAR PIPE TO DETERMINE THE STEEL AREA.]
 - (d) FOR THE SELECTED DIAMETER, WALL THICKNESS, DESIGN FILL HEIGHT AND CONCRETE STRENGTH, DETERMINE THE AREA OF STEEL REQUIRED FOR THE INNER CAGE OF THE PIPE IN THE TYPE A STANDARD INSTALLATION TABLES FOR CIRCULAR PIPES. USE THIS AREA FOR EACH, INNER AND OUTER, CAGE FOR THE ELLIPTICAL PIPE DESIGN.
- 8) USE PAIDD SOFTWARE ONLY FOR PIPE DESIGNS NOT PROVIDED BY BD-636M.
- 9) STEEL AREAS SPECIFIED IN THE FILL HEIGHT / STEEL AREA TABLES ARE TO BE ACHIEVED USING ONE LAYER OF REINFORCEMENT FOR EACH CAGE. TWO LAYERS MAY BE SUBSTITUTED FOR ONE LAYER PROVIDED THE SUM OF THE STEEL AREAS OF THE 2 LAYERS IS EQUAL TO THE AREA OF STEEL FOR THE SINGLE LAYER CAGE. WHEN SUBSTITUTING, SPACING OF REINFORCEMENT IS TO REMAIN THE SAME. DESIGNING FOR 2 LAYERS OF REINFORCEMENT AND PROVIDING ONE LAYER OF REINFORCEMENT OF EQUIVALENT AREA IS NOT PERMITTED.

DESIGN TABLES FOR HORIZONTAL ELLIPTICAL PIPE-STANDARD INSTALLATION- TYPE A / TYPE B

COMMONWEALTH OF PENNSYLVANIA
DEPARTMENT OF TRANSPORTATION
BUREAU OF PROJECT DELIVERY

STANDARD
REINFORCED CONCRETE PIPES
ELLIPTICAL PIPE DESIGN TABLES

RECOMMENDED APR. 29, 2016

Thomas P. Maiore
CHIEF BRIDGE ENGINEER

RECOMMENDED APR. 29, 2016

Brenda S. Thompson
DIRECTOR, BUR. OF PROJECT DELIVERY

SHEET 8 OF 10

BD-636M

TYPE A SHORING/TRENCH BOX VERTICAL ELLIPTICAL PIPE - STEEL AREAS (in ² /ft.)												
Equivalent Round (in.)	Rise /Span (in.)	Wall Thick. (in.)	f' c (psi)	Required Fill/Cover Height								
				H < 1.5'	1.5' <= H < 2'	2' <= H < 3'	3' <= H < 7'	7' <= H < 10'	15'	20'	25'	
36"	45/29	4 1/2"	4000	**	0.23	0.19	0.14	0.12	0.15	0.19	0.23	**
				**	0.12	0.10	0.07	0.07	0.07	0.08	0.09	**
42"	53/34	5"	4000	**	0.28	0.23	0.17	0.15	0.18	0.23	0.28	**
				**	0.14	0.12	0.09	0.08	0.07	0.09	0.12	**
48"	60/38	5 1/2"	4000	**	0.20	0.18	0.15	0.15	0.20	0.25	0.31	**
				**	0.10	0.09	0.08	0.08	0.08	0.11	0.13	**
54"	68/43	6"	4000	**	0.21	0.19	0.18	0.18	0.23	0.29	**	**
				**	0.11	0.10	0.09	0.09	0.10	0.12	**	**
			5000	**	*	*	*	*	*	*	0.30	**
				**	*	*	*	*	*	*	*	0.13
60"	76/48	6 1/2"	4000	**	0.22	0.22	0.20	0.21	0.27	0.33	**	**
				**	0.11	0.11	0.10	0.11	0.11	0.14	**	**
			5000	**	*	*	*	*	*	*	0.34	**
				**	*	*	*	*	*	*	*	0.15
66"	83/53	7"	4000	**	0.24	0.23	0.22	0.23	0.31	0.38	**	**
				**	0.12	0.12	0.11	0.12	0.13	0.16	**	**
			5000	**	*	*	*	*	*	*	0.39	**
				**	*	*	*	*	*	*	*	0.17
72"	91/58	7 1/2"	4000	**	0.25	0.25	0.25	0.26	0.34	**	**	**
				**	0.13	0.13	0.13	0.13	0.15	**	**	**
			5000	**	*	*	*	*	*	*	0.37	0.44
				**	*	*	*	*	*	*	*	0.19
78"	98/63	8"	4000	**	0.26	0.26	0.27	0.29	0.38	**	**	**
				**	0.13	0.13	0.14	0.15	0.16	**	**	**
			5000	**	*	*	*	*	*	0.41	0.48	**
				**	*	*	*	*	*	0.18	0.21	**
84"	106/68	8 1/2"	4000	**	0.28	0.28	0.29	0.33	0.42	**	**	**
				**	0.14	0.14	0.15	0.17	0.18	**	**	**
			5000	**	*	*	*	*	*	0.45	**	**
				**	*	*	*	*	*	0.20	**	**
			6000	**	*	*	*	*	*	*	0.53	**
				**	*	*	*	*	*	*	*	0.23
90"	113/72	9"	4000	**	0.29	0.29	0.30	0.35	0.45	**	**	**
				**	0.15	0.15	0.15	0.18	0.19	**	**	**
			5000	**	*	*	*	*	*	0.48	**	**
				**	*	*	*	*	*	0.21	**	**
			6000	**	*	*	*	*	*	*	0.56	**
				**	*	*	*	*	*	*	0.24	**
96"	121/77	9 1/2"	4000	**	0.31	0.31	0.33	0.38	0.49	**	**	**
				**	0.16	0.16	0.17	0.19	0.21	**	**	**
			5000	**	*	*	*	*	*	0.52	**	**
				**	*	*	*	*	*	0.23	**	**
			6000	**	*	*	*	*	*	*	0.61	**
				**	*	*	*	*	*	*	0.26	**
102"	128/82	9 3/4"	4000	**	0.34	0.34	0.37	0.43	**	**	**	**
				**	0.17	0.17	0.19	0.22	**	**	**	**
			5000	**	*	*	*	*	0.48	0.58	**	**
				**	*	*	*	*	0.21	0.25	**	**
			6000	**	*	*	*	*	*	*	0.73	**
				**	*	*	*	*	*	*	0.30	**
108"	136/87	10"	4000	**	0.36	0.36	0.41	0.49	*	**	**	**
				**	0.18	0.18	0.21	0.25	*	**	**	**
			5000	**	*	*	*	*	0.53	0.69	**	**
				**	*	*	*	*	0.24	0.28	**	**
			6000	**	*	*	*	*	*	*	0.86	**
				**	*	*	*	*	*	*	0.33	**
114"	143/92	10 1/2"	4000	**	0.39	0.39	0.44	0.55	**	**	**	**
				**	0.20	0.20	0.22	0.28	**	**	**	**
			5000	**	*	*	*	*	0.57	**	**	**
				**	*	*	*	*	0.25	**	**	**
			6000	**	*	*	*	*	*	0.69	**	**
				**	*	*	*	*	*	0.30	**	**
120"	151/97	11"	4000	**	0.41	0.41	0.48	0.66	*	**	**	**
				**	0.21	0.21	0.24	0.33	*	**	**	**
			5000	**	*	*	*	*	0.61	**	**	**
				**	*	*	*	*	0.27	**	**	**
			6000	**	*	*	*	*	*	0.76	**	**
				**	*	*	*	*	*	0.32	**	**

PROOF TEST LOAD TABLE FOR VERTICAL ELLIPTICAL PIPE TYPE A SHORING TRENCH - BOX INSTALLATION (lbs/LF/FT. OF DIAMETER)											
REQUIRED FILL/COVER HEIGHT (FT.) / PROOF TEST LOADS											
Equivalent Round (in.)	Rise /Span (in.)	1.5' <= H < 2'	2' <= H < 3'	3' <= H < 7'	7' <= H < 10'	10' <= H < 15'	15' <= H < 20'	20' <= H < 25'			
36	14x29	1007	949	923	1181	1677	2198	2727			
42	53x34	931	889	909	1168	1662	2179	2705			
48	60x38	920	865	1113	1465	2110	2777	3453			
54	68x43	864	823	1101	1454	2098	2762	3435			
60	76x48	816	788	1091	1446	2088	2751	3421			
66	83x53	812	757	1083	1438	2080	2741	3409			
72	91x58	775	731	1075	1432	2074	2733	3400			
78	98x63	778	731	1068	1426	2068	2726	3392			
84	106x68	748	709	1062	1422	2063	2720	3385			
90	113x72	725	694	1058	1418	2059	2716	3380			
96	121x77	701	676	1053	1414	2055	2712	3374			
102	128x82	678	660	1048	1410	2052	2708	3370			
108	136x87	666	666	1043	1407	2048	2704	3365			
114	143x92	652	652	1039	1404	2045	2701	3361			
120	151x97	626	626	1036	1401	2043	2698	3358			

NOTE : PROOF LOADS ARE AN INDICATION OF CRACK CONTROLS AND NOT NECESSARILY STRENGTH CONTROL. ACTUAL STRUCTURAL DESIGN (CONCRETE STRENGTH, AREA OF STEEL AND WALL THICKNESS) IS BASED UPON FLEXURE, CRACKING, OR SHEAR - WHICHEVER GOVERNS. FOR SUBSTITUTION OF PIPES RELY UPON THE MAXIMUM VS. MINIMUM FILL HEIGHT STAMP. DO NOT USE THE PROOF LOAD FOR SUBSTITUTION PURPOSES. SEE FIGURE "FLEXURE - SHEAR - CRACK CONTROL" AND EXAMPLE ON SHEET 2.

TYPE A SHORING/TRENCH BOX HORIZONTAL ELLIPTICAL PIPE - STEEL AREAS (in ² /ft.)													
Equivalent Round (in.)	Rise /Span (in.)	Wall Thick. (in.)	f' c (psi)	Required Fill/Cover Height									
				H < 1.5'	1.5' <= H < 2'	2' <= H < 3'	3' <= H < 7'	7' <= H < 10'	10' <= H < 15'	15' <= H < 20'	20' <= H < 25'		
18"	14x23	2 3/4"	4000	**	0.25	0.19	0.14	0.13					
24"	19x30	3 1/4"	4000	**	0.37	0.27	0.20	0.18					
27"	22x34	3 1/2"	4000	**	0.39	0.33	0.25	0.22					
30"	24x38	3 3/4"	4000	**	0.39	0.29	0.24	0.28					
				**	0.39	0.29	0.24	0.28					
33"	27x42	3 3/4"	4000	**	0.48	0.35	0.29	0.40					
				**	0.48	0.35	0.29	0.40					
36"	29x45	4 1/2"	4000	**	0.33	0.32	0.27	0.32					
				**	0.33	0.32	0.27	0.32					
42"	34x53	5"	4000	**	0.35	0.35	0.33	0.45					
				**	0.35	0.35	0.33	0.45					
48"	38x60	5 1/2"	4000	**	0.37	0.39	0.42	0.56					
				**	0.37	0.39	0.42	0.56					
54"	43x68	6"	4000	**	0.43	0.45	0.54	0.71					
				**	0.43	0.45	0.54	0.71					
60"	48x76	6 1/2"	4000	**	0.50	0.54	0.66	**					
				**	0.50	0.54	0.66	**					
			5000	**	*	*	*	0.81					
				**	*	*	*	0.81					
66"	53x83	7"	4000	**	0.57	0.60	0.77	**					
				**	0.57	0.60	0.77	**					
			5000	**	*	*	*	0.94					
				**	*	*	*	0.94					
72"	58x91	7 1/2"	4000	**	0.66	0.70	0.92	**					
				**	0.66	0.70	0.92	**					
			6000	**	*	*	*	1.03					
				**	*	*	*	1.03					
78"	63x98	8"	4000	**	0.73	0.78	**	**					
				**	0.73	0.78	**	**					
			5000	**	*	*	*	0.98					
				**	*	*	*	0.98					
			6000	**	*	*	*	1.16					
				**	*	*	*	1.16					
84"	68x106	8 1/2"	4000	**	0.84	0.89	**	**					
				**	0.84	0.89	**	**					
			6000	**	*	*	*	1.07					
				**	*	*	*	1.07					
90"	72x113	9"	4000	**	0.92	0.99	**	**					
				**	0.92	0.99	**	**					
96"	77x121	9 1/2"	4000	**	1.06	**	**	**					
				**	1.06	**	**	**					
			5000	**	*	1.04	**	**					
				**	*	1.04	**	**					
			7000	**	*	*	1.31	**					
				**	*	*	1.31	**					
102"	82x128	9 3/4"	5000	**	1.13	1.21	**	**					
				**	1.13	1.21	**	**					
			6000	**	*	*	1.52	**					
				**	*	*	1.52	**					
108"	87x136	10"	5000	**	1.32	**	**	**					
				**	1.32	**	**	**					
			6000	**	*	1.33	**	**					
				**	*	1.33	**	**					
114"	92x143	10 1/2"	5000	**	1.43	**	**	**					
				**	1.43	**	**	**					
			6000	**	*	1.44	**	**					
				**	*	1.44	**	**					
120"	97x151	11"	4000	**	**	**	**	**					
				**	**	**	**	**					

PROOF TEST LOAD TABLE FOR HORIZONTAL ELLIPTICAL PIPE TYPE A SHORING TRENCH - BOX INSTALLATION (lbs/LF/FT. OF DIAMETER)											
REQUIRED FILL/COVER HEIGHT (FT.) / PROOF TEST LOADS											
Equivalent Round (in.)	Rise /Span (in.)	1.5' <= H <									

TYPE B SHORING/TRENCH BOX VERTICAL ELLIPTICAL PIPE - STEEL AREAS (in ² /ft.)												
Equivalent Round (in.)	Rise /Span (in.)	Wall Thick. (in.)	f' c (psi)	Required Fill/Cover Height								
				H < 1.5'	1.5' ≤ H < 2'	2' ≤ H < 3'	3' ≤ H < 4'	4' ≤ H < 10'	10' ≤ H < 15'	15' ≤ H < 20'	20' ≤ H < 25'	
36"	45/29	4 1/2"	4000	**	0.22	0.18	0.13	0.11	0.16	0.20	0.25	**
42"	53/34	5"	4000	**	0.27	0.22	0.16	0.14	0.20	0.25	0.32	**
48"	60/38	5 1/2"	4000	**	0.19	0.17	0.14	0.14	0.20	0.26	0.39	**
54"	68/43	6"	4000	**	0.20	0.20	0.17	0.17	0.23	0.30	0.52	**
60"	76/48	6 1/2"	4000	**	0.21	0.21	0.19	0.19	0.27	0.38	0.67	**
66"	83/53	7"	4000	**	0.22	0.22	0.21	0.22	0.30	0.49	**	**
			5000	**	0.11	0.11	0.10	0.10	0.15	0.25	**	**
			6000	**	*	*	*	*	*	*	0.61	**
			6000	**	*	*	*	*	*	*	0.31	**
72"	91/58	7 1/2"	4000	**	0.23	0.23	0.23	0.25	0.34	0.61	**	**
			5000	**	0.12	0.11	0.11	0.11	0.17	0.32	**	**
			6000	**	*	*	*	*	*	*	0.74	**
			6000	**	*	*	*	*	*	*	0.37	**
78"	98/63	8"	4000	**	0.25	0.25	0.26	0.28	0.40	0.75	**	**
			5000	**	0.12	0.12	0.12	0.12	0.20	0.38	**	**
			6000	**	*	*	*	*	*	*	0.71	**
			6000	**	*	*	*	*	*	*	0.36	**
84"	106/68	8 1/2"	4000	**	0.26	0.26	0.27	0.31	0.46	**	**	**
			5000	**	0.13	0.13	0.13	0.14	0.23	**	**	**
			6000	**	*	*	*	*	*	0.63	**	**
			6000	**	*	*	*	*	*	0.32	**	**
			6000	**	*	*	*	*	*	*	0.81	**
			6000	**	*	*	*	*	*	*	0.42	**
90"	113/72	9"	4000	**	0.27	0.27	0.29	0.33	0.51	**	**	**
			5000	**	0.13	0.13	0.13	0.15	0.26	**	**	**
			6000	**	*	*	*	*	*	0.71	**	**
			6000	**	*	*	*	*	*	0.36	**	**
96"	121/77	9 1/2"	4000	**	0.29	0.29	0.31	0.36	0.62	**	**	**
			5000	**	0.14	0.14	0.14	0.16	0.31	**	**	**
			6000	**	*	*	*	*	*	0.83	**	**
			6000	**	*	*	*	*	*	0.42	**	**
102"	128/82	9 3/4"	4000	**	0.31	0.32	0.35	0.40	0.79	**	**	**
			5000	**	0.15	0.15	0.15	0.18	0.40	**	**	**
			6000	**	*	*	*	*	*	0.83	**	**
			6000	**	*	*	*	*	*	0.42	**	**
108"	136/87	10"	4000	**	0.34	0.34	0.38	0.46	**	**	**	**
			5000	**	0.16	0.16	0.17	0.20	**	**	**	**
			6000	**	*	*	*	*	0.72	**	**	**
			6000	**	*	*	*	*	0.36	**	**	**
114"	143/92	10 1/2"	4000	**	0.36	0.36	0.42	0.52	**	**	**	**
			5000	**	0.17	0.17	0.19	0.22	**	**	**	**
			6000	**	*	*	*	*	0.80	**	**	**
			6000	**	*	*	*	*	0.40	**	**	**
120"	151/97	11"	4000	**	0.38	0.39	0.45	0.58	**	**	**	**
			5000	**	0.18	0.18	0.20	0.23	**	**	**	**
			6000	**	*	*	*	*	0.90	**	**	**
			6000	**	*	*	*	*	0.45	**	**	**

PROOF TEST LOAD TABLE FOR VERTICAL ELLIPTICAL PIPE TYPE B SHORING TRENCH - BOX INSTALLATION (lbs/LF/FT. OF DIAMETER)										
REQUIRED FILL/COVER HEIGHT (FT.) / PROOF TEST LOADS										
Equivalent Round (in.)	Rise /Span (in.)	1.5' ≤ H < 2'	2' ≤ H < 3'	3' ≤ H < 4'	4' ≤ H < 10'	10' ≤ H < 15'	15' ≤ H < 20'	20' ≤ H < 25'		
36	45x29"	957	901	877	1122	1594	2088	2591		
42	53x34"	884	845	863	1110	1579	2070	2569		
48	60x38"	874	822	1057	1391	2004	2638	3280		
54	68x43"	821	782	1046	1382	1993	2624	3263		
60	76x48"	775	748	1037	1373	1984	2613	3250		
66	83x53"	771	720	1029	1366	1976	2604	3239		
72	91x58"	736	694	1021	1360	1970	2596	3230		
78	98x63"	739	695	1015	1355	1964	2590	3222		
84	106x68"	710	674	1009	1350	1960	2584	3215		
90	113x72"	689	659	1005	1347	1956	2580	3211		
96	121x77"	666	642	1000	1343	1952	2576	3206		
102	128x82"	644	627	995	1340	1949	2572	3201		
108	136x87"	633	633	991	1336	1946	2569	3197		
114	143x92"	619	619	987	1333	1943	2566	3193		
120	151x97"	599	595	984	1331	1940	2563	3190		

NOTE : PROOF LOADS ARE AN INDICATION OF CRACK CONTROLS AND NOT NECESSARILY STRENGTH CONTROL. ACTUAL STRUCTURAL DESIGN (CONCRETE STRENGTH, AREA OF STEEL AND WALL THICKNESS) IS BASED UPON FLEXURE, CRACKING, OR SHEAR - WHICHEVER GOVERNS. FOR SUBSTITUTION OF PIPES RELY UPON THE MAXIMUM VS. MINIMUM FILL HEIGHT STAMP. DO NOT USE THE PROOF LOAD FOR SUBSTITUTION PURPOSES. SEE FIGURE "FLEXURE - SHEAR - CRACK CONTROL" AND EXAMPLE ON SHEET 2.

TYPE B SHORING/TRENCH BOX HORIZONTAL ELLIPTICAL PIPE - STEEL AREAS (in ² /ft.)												
Equivalent Round (in.)	Rise /Span (in.)	Wall Thick. (in.)	f' c (psi)	Required Fill/Cover Height								
				H < 1.5'	1.5' ≤ H < 2'	2' ≤ H < 3'	3' ≤ H < 4'	4' ≤ H < 10'	10' ≤ H < 15'	15' ≤ H < 20'	20' ≤ H < 25'	
18"	14x23	2 3/4"	4000	**	0.22	0.18	0.13	0.12				
24"	19x30	3 1/4"	4000	**	0.32	0.25	0.19	0.17				
27"	22x34	3 3/4"	4000	**	0.38	0.31	0.23	0.21				
30"	24x38	3 3/4"	4000	**	0.34	0.27	0.22	0.26				
33"	27x42	3 3/4"	4000	**	0.37	0.33	0.27	0.38				
				**	0.37	0.33	0.27	0.38				
36"	29x45	4 1/2"	4000	**	0.30	0.30	0.25	0.30				
				**	0.30	0.30	0.25	0.30				
42"	34x53	5"	4000	**	0.33	0.33	0.32	0.43				
				**	0.33	0.33	0.32	0.43				
48"	38x60	5 1/2"	4000	**	0.37	0.37	0.40	0.53				
				**	0.37	0.37	0.40	0.53				
54"	43x68	6"	4000	**	0.43	0.43	0.51	0.67				
				**	0.43	0.43	0.51	0.67				
60"	48x76	6 1/2"	4000	**	0.51	0.51	0.63	0.82				
				**	0.51	0.51	0.63	0.82				
66"	53x83	7"	4000	**	0.57	0.57	0.73	0.89				
				**	0.57	0.57	0.73	0.89				
72"	58x91	7 1/2"	4000	**	0.67	0.67	0.87	1.03				
				**	0.67	0.67	0.87	1.03				
78"	63x98	8"	4000	**	0.74	0.74	**	**				
				**	0.74	0.74	**	**				
			5000	**	*	*	0.93	**				
			6000	**	*	*	0.93	**				
			6000	**	*	*	*	1.10				
			6000	**	*	*	*	1.10				
84"	68x106	8 1/2"	4000	**	0.85	0.85	**	**				
				**	0.85	0.85	**	**				
			5000	**	*	*	1.08	**				
			6000	**	*	*	1.08	**				
90"	72x113	9"	4000	**	0.94	0.94	**	**				
				**	0.94	0.94	**	**				
			6000	**	*	*	1.14	**				
			6000	**	*	*	1.14	**				
96"	77x121	9 1/2"	4000	**	1.06	1.06	**	**				
				**	1.06	1.06	**	**				
			6000	**	*	*	1.30	**				
			6000	**	*	*	1.30	**				
102"	82x128	9 3/4"	5000	**	1.14	1.14	**	**				
				**	1.14	1.14	**	**				
108"	87x136	10"	5000	**	1.33	1.33	**	***				
				**	1.33	1.33	**	***				
114"	92x143	10 1/2"	5000	**	1.44	1.44	**	***				
				**	1.44	1.44	**	***				
120"	97x151	11"	4000	**	**	**	**	***				
				**	**	**	**	***				

PROOF TEST LOAD TABLE FOR HORIZONTAL ELLIPTICAL PIPE TYPE B SHORING TRENCH - BOX INSTALLATION (lbs/LF/FT. OF DIAMETER)										
REQUIRED FILL/COVER HEIGHT (FT.) / PROOF TEST LOADS										
Equivalent Round (in.)	Rise /Span (in.)	1.5' ≤ H < 2'	2' ≤ H < 3'	3' ≤ H < 4'	4' ≤ H < 10'	10' ≤ H < 15'	15' ≤ H < 20'	20' ≤ H < 25'		
18	14x23"	1515	1296	1050	1155	1624	2122	2631		
24	19x30"	1375	1198	994	1134	1596	2087	2588		
27	22x34"	1310	1152	968	1125	1586	2073	2571		
30	24x38"	1319	1126	1091	1408	2011	2642	3282		
33	27x42"	1265	1089	1084	1401	2003	2631	3268		
36	29x45"	1228	1064	1079	1396	1997	2624	3260		
42	34x53"	1205	1006	1068	1386	1985	2608	3241		
48	38x60"	1138	962	1060	1379	1977	2599	3229		
54	43x68"	1134	957	1052	1372	1969	2590	3218		
60	48x76"	1073	917	1045	1367	1963	2582	3210		
66	53x83"	1026	887	1039	1362	1959	2577	3204		
72	58x91"	921	892	1034	1358	1955	2572	3198		
78	63x98"	950	837	1029	1355	1951	2568	3193		
84	68x106"	863	776	1024	1351	1948	2565	3189		
90	72x113"	799	762	1020	1348	1946	2562	3186		
96	77x121"	738	715	1016	1345	1943	2559	3182		
102	82x128"	693	681	1012	1343	1941	2557	3180		
108	87x136"	649	647	1009	1340	1939	2554	3177		
114	92x143"	621	621	1006	1338	1937	2552	3175		
120	97x151"	595	595	1002	1336	1				