

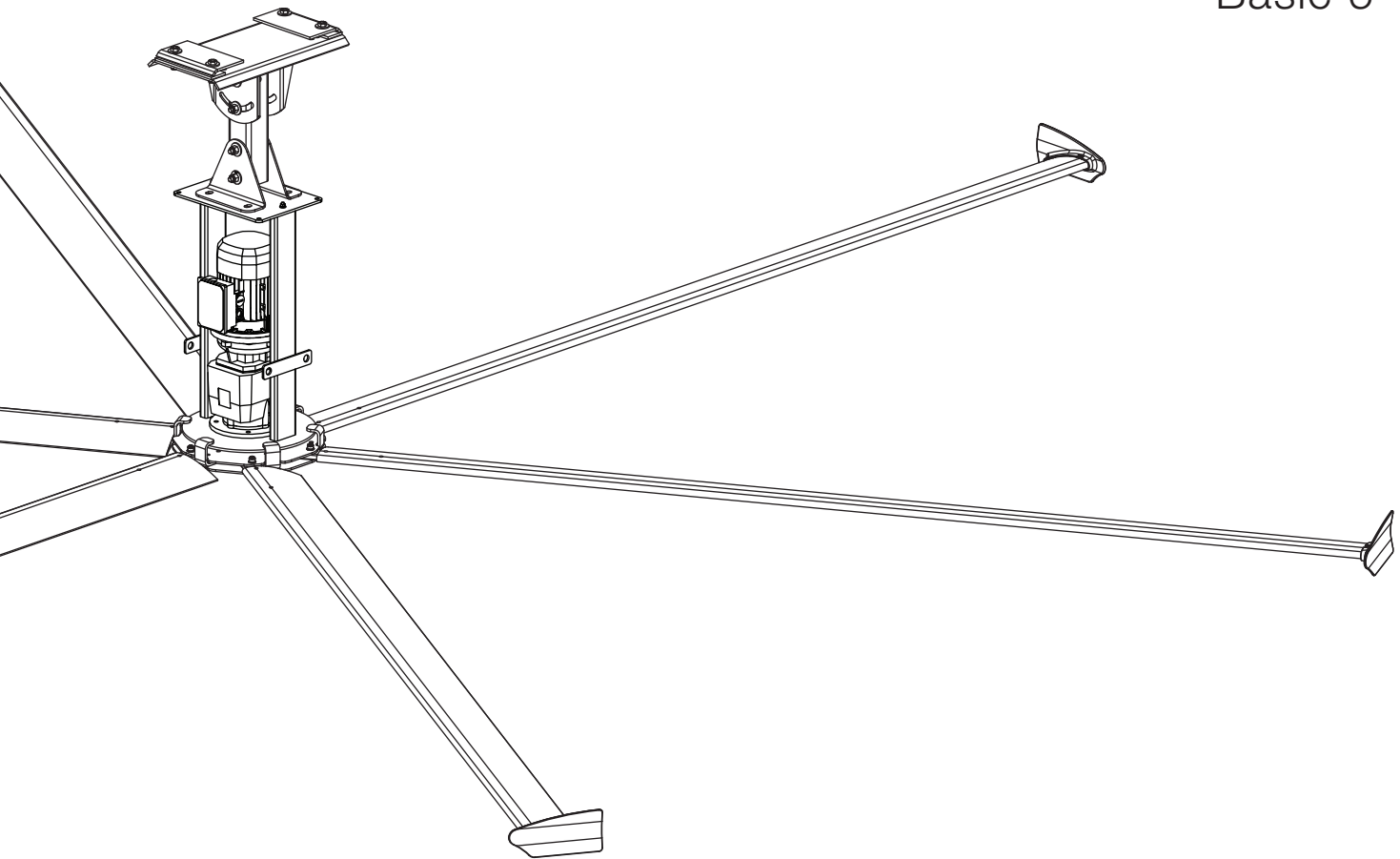

INSTALLATION GUIDE

Basic 6[®]



Installation Checklist

Did a structural engineer approve the mounting structure? See page 7 for Big Ass Fans approved mounting structures.

Do you have the correct safety cable? Are you familiar with its use? See page 18 for information on properly securing the safety cable.

Will the fan be installed so that the airfoils are at least 10 ft (3.05 m) above the floor?

Will the fan be installed so that the airfoils have at least 2 ft (0.61 m) of clearance from obstructions?

Will the fan be installed so that it is not subjected to high winds (such as from an HVAC system or near a large garage door)? If the fan is mounted at the same level or higher than the diffuser, the winglets must be at a distance that is at least 1x the measure of the fan's diameter. If the fan is mounted at the same height or below the diffuser, the winglets must be at a distance that is at least 2x the measure of the fan's diameter.

Will the distance between multiple fans be at least 2.5x the fans' diameter when measured from the centers of the fans?

If installing on an I-beam, is the upper yoke the correct size? See page 10 for more information on installing the fan on an I-beam.

If you ordered multiple fans, did you keep the parts of each fan together?

Some motors are labeled, "This Unit Factory Wired for 460 VAC." If you have a 200–250V or 100–125V controller, did you rewire the motor for proper use?

Do you have the correct power circuit for the fan controller? See page 2 for information on selecting the correct circuit/fuse for the fan controller.

Customer Service: 1-877-BIG-FANS
(International: +1 859 233 1271)

Installation Guide

12'-24' Basic 6®

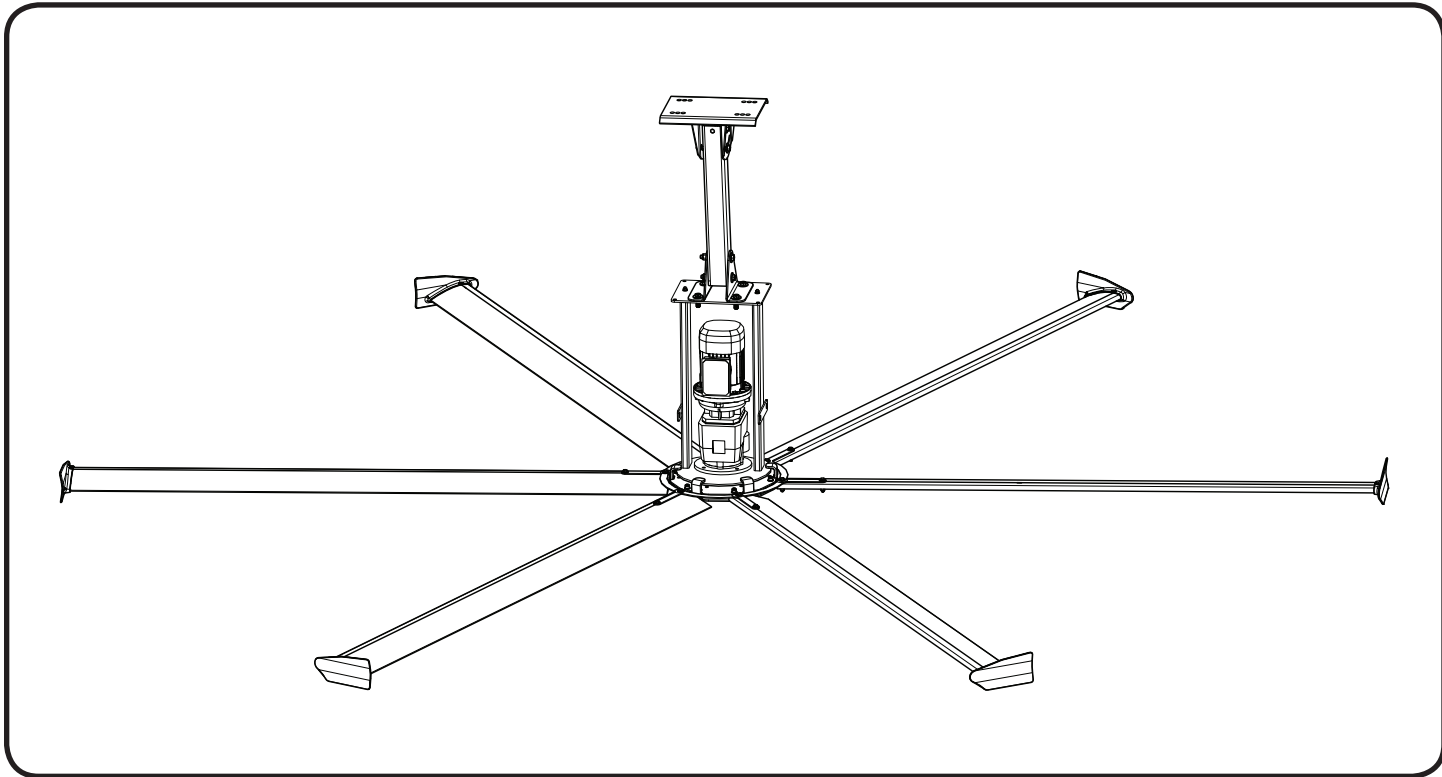

Installation Guide:
Apr. 2015
Rev. P



This product was manufactured in a plant whose Management System is certified as being in conformity with ISO 9001:2008.



Intertek

Conforms to ANSI/UL STD 507: Electric Fans
Certified to CAN/CSA C22.2 No.113: Fans & Ventilators

Contact Information

Manufacturing
2425 Merchant Street
Lexington, KY 40511
1-877-BIG-FANS
www.bigassfans.com

Customer Service
2348 Innovation Drive
Lexington, KY 40511
1-877-BIG-FANS
Intl.: +1 859 233 1271
www.bigassfans.com

Warranty Returns
800 Winchester Road
Lexington, KY 40505
1-877-BIG-FANS
www.bigassfans.com

Australia Office
Unit 22, 1029 Manly Road
Tingalpa QLD 4173, Australia
(07) 3292 0100
www.bigassfans.com/au

Basic 6 and the Basic 6 logo are trademarks of Delta T Corporation, registered in the United States and/or other countries. All other trademarks used herein are the properties of their respective owners. No part of this document may be reproduced or translated into a different language without the prior written consent of Big Ass Fans. The information contained in this document is subject to change without notice. For the most up-to-date information, see the online Basic 6 Installation Guide at www.bigassfans.com.

www.bigasssolutions.com/patents



IMPORTANT SAFETY INSTRUCTIONS

READ AND SAVE THESE INSTRUCTIONS

TO REDUCE THE RISK OF FIRE, ELECTRIC SHOCK, OR INJURY TO PERSONS, OBSERVE THE FOLLOWING:

WARNING: Installation work and electrical wiring must be done by qualified person(s) in accordance with all applicable codes and standards.

WARNING: When cutting or drilling into a wall or ceiling, do not damage electrical wiring and other hidden utilities.

CAUTION: The installation of a Big Ass Fan must be in accordance with the requirements specified in this installation manual and with any additional requirements set forth by the national electric code (NEC), ANSI/NFPA 70-2011, and all local codes. Code compliance is ultimately YOUR responsibility!

WARNING: The fan controllers contain high voltage capacitors that take time to discharge after removal of mains supply. Before working on the fan controller, ensure isolation of mains supply from line inputs at the fan controller's disconnect. Wait 3 minutes for capacitors to discharge to safe voltage levels. Failure to do so may result in personal injury or death. **NOTE:** Darkened display LEDs are not an indication of safe voltage levels.

CAUTION: Exercise caution and common sense when powering the fan. Do not connect the fan to a damaged or hazardous power source. Do not attempt to resolve electrical malfunctions or failures on your own. Contact Big Ass Fans if you have any questions regarding the electrical installation of this fan.

WARNING: To reduce the risk of fire, electric shock, and injury to persons, Big Ass Fans must be installed with Big Ass Fan supplied controllers that are marked (on their cartons) to indicate the suitability with this model. Other parts cannot be substituted.

CAUTION: When service or replacement of a component in the fan requires the removal or disconnection of a safety device, the safety device is to be reinstalled or remounted as previously installed.

WARNING: Risk of fire, electric shock, or injury to persons during cleaning and user-maintenance! Disconnect the appliance from the power supply before servicing.

WARNING: Use this unit only in the manner intended by the manufacturer. If you have questions, contact the manufacturer.

WARNING: Before servicing or cleaning unit, switch power off at service panel and lock the service disconnecting means to prevent power from being switched on accidentally. When the service disconnecting means cannot be locked, securely fasten a prominent warning device, such as a tag, to the service panel.

CAUTION: Do not bend the airfoils when installing, adjusting, or cleaning the fan. Do not insert foreign objects between rotating airfoils.

WARNING: Stay alert and use common sense when installing fans. Do not install fans if tired or under the influence of drugs, alcohol, or medication. A moment of inattention while installing fans may result in serious personal injury.

CAUTION: The installation of this fan requires the use of some power tools. Follow the safety procedures found in the owner's manual for each of these tools and do not use them for purposes other than those intended by the manufacturer.

CAUTION: The Big Ass Fans product warranty will not cover equipment damage or failure caused by improper installation.

Leave this installation guide with the owner of the fan after installation is complete.

WARNING: This appliance is not intended for use by persons (including children) with reduced physical, sensory or mental capabilities, or lack of experience and knowledge, unless they have been given supervision or instruction concerning use of the appliance by a person responsible for their safety. Children should be supervised to ensure that they do not play with the appliance.

ATTENTION: If installing the fan in the United States, the fan must be installed per the following National Fire Protection Association (NFPA) guidelines:

- The fan must be centered approximately between four adjacent sprinklers.
- The vertical distance from the fan to the sprinkler deflector must be at least 3 ft (91.4 cm).
- The fan must be interlocked to shut down immediately upon receiving a waterflow signal from the alarm system.

Mounting Reference Guide

The following is intended as a reference guide for Basic 6® fan mounting methods. See the referenced pages for complete fan installation and operating instructions. Consult a structural engineer to determine which mounting method best suits your building structure.

I-Beam

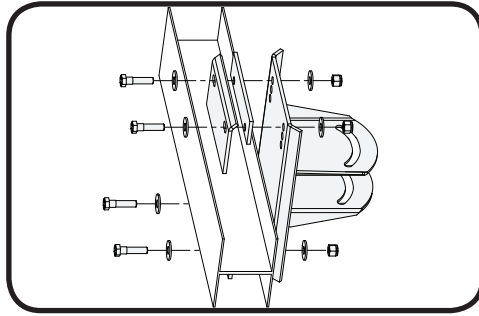
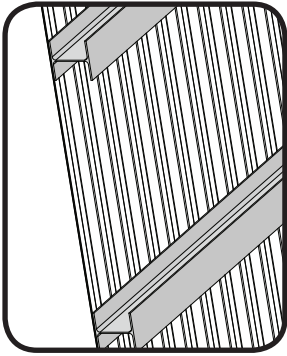

See page 10 for mounting instructions.

Bar Joists

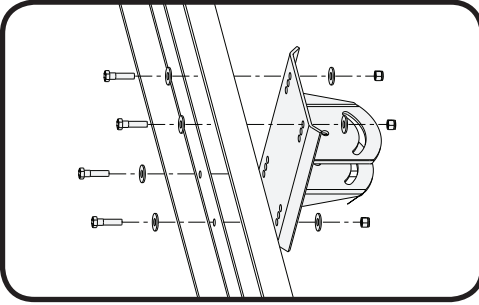
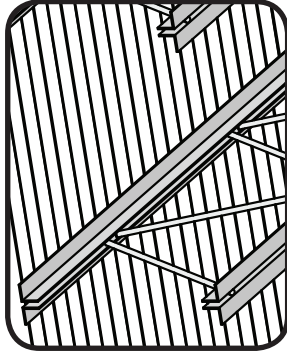

See page 12 for mounting instructions.

Z-Purlins

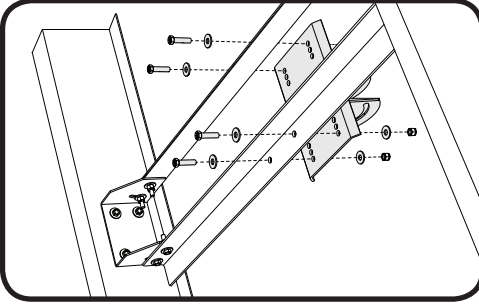
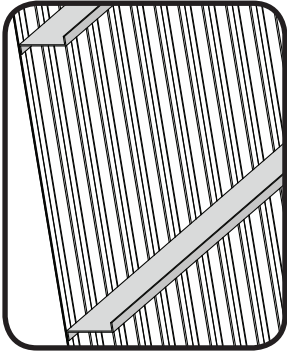

See complete instructions included with the Z-Purlin Installation Kit.

Solid Beam

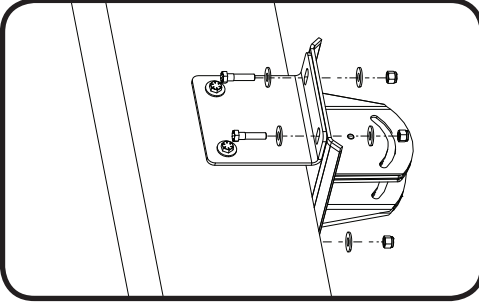
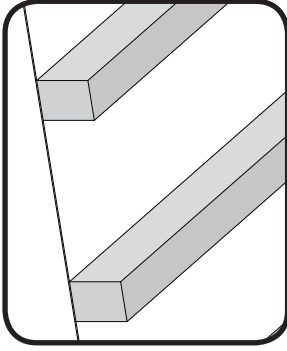

See complete instructions included with the L-Bracket Installation Kit.

I-Beam (Angled)

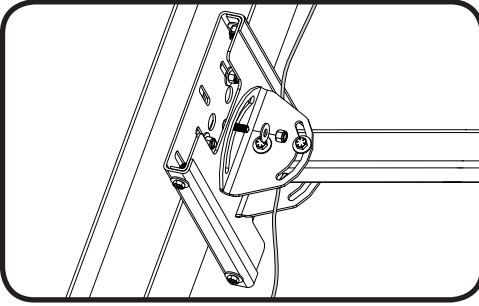
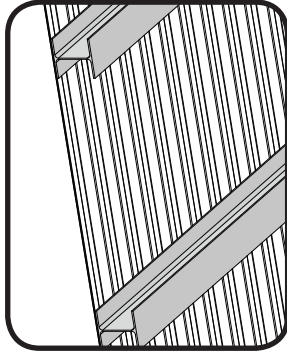

See complete instructions included with the Compound Angle Mount Installation Kit.

Contents

Introduction	Safety Instructions.....	ii
	Mounting Reference Guide.....	iii
	Thank You.....	1
	About Big Ass Fans.....	1
Pre-Installation	About this Fan.....	2
	What's in the Box.....	3
	Parts Included.....	4
	Tools Needed.....	5
	Understanding Roof Pitch.....	5
	Fan Diagram.....	6
	Preparing the Work Site.....	7
	Understanding Airflow Patterns.....	8
Mounting Structure: I-Beam	1. Measure I-Beam Width.....	10
	2. Attach Upper Yoke (to I-Beam).....	11
Mounting Structure: Bar Joists	1. Select Proper Angle Irons.....	12
	2. Pre-drill Angle Irons.....	13
	3. Fasten Angle Irons Together (if span is longer than 8 ft).....	13
	4a. Fasten Single Angle Irons to Roof Structure Mounting Points.....	14
	4b. Fasten Double Angle Irons to Roof Structure Mounting Points.....	15
	5a. Attach Upper Yoke (to Angle Irons).....	16
5b. Attach Main Fan Unit (to Angle Irons).....	17	
Hanging the Fan	1. Attach Extension Tube (to Upper Yoke).....	18
	2. Secure Safety Cable.....	18
	3. Attach Lower Yoke (to Extension Tube).....	19
	4. Attach Main Fan Unit (to Lower Yoke).....	19
	5. Confirm Orientation.....	19
Installing Guy Wires	1. Attach Locking Carabiners to Main Fan Unit.....	20
	2. Attach Beam Clamp.....	20
	3. Route Guy Wire through Gripple®.....	21
	4. Install Remaining Guy Wires.....	21
Installing Airfoils	1. Attach Winglets to Airfoils.....	22
	2. Attach Airfoils to Hub.....	22
Electrical Installation	Electrical Installation Safety.....	23
	Electrical Installation Overview.....	24
	Controller Storage.....	24
	Power Requirements for Fan Controllers.....	24
	Mounting the Wall Controller.....	24
	Input Power Conditioning.....	25
	Conduit and Piping Guidelines.....	25
	Power Wiring Guidelines.....	26
	Grounding.....	27
	Installing the Electronic Programming Module (EPM).....	28
	Wiring: ESFR (Early Suppression Fast Response).....	29
	Wiring: 100–125V/200–250V Single-Phase Fan Controllers.....	30
	Wiring: 200–250V Three-Phase Fan Controllers.....	31
	Wiring: 400–480V & 575–600V Three-Phase Fan Controllers.....	32
	Daisy Chaining.....	33
	Wiring the Motor: 9 Lead, Dual Voltage, Wye Motor Configurations.....	34
	Operating the Fan Controller.....	35

Additional Input Power Considerations	Input Voltage Irregularities.....	36
	Delta Secondary.....	36
	Branch Circuit Protection.....	37
Operating the Fan	Heating Season.....	38
	Cooling Season.....	38
Preventive Maintenance	Annual Preventive Maintenance.....	39
	General Preventive Maintenance.....	39
	Annual Maintenance Checklist.....	41
Troubleshooting	Cutting the Extension Tube.....	43
	General Troubleshooting.....	43
	Troubleshooting the Fan Controller.....	44
Warranty Return Instructions	Acknowledgment & Return Instructions.....	47
	Warranty Claim Form Instructions.....	48
	Warranty Claim Form.....	49
	Responsibility Agreement.....	50
Big Ass Fan Certified Installers	Check-In Procedure.....	51
	Close-Out Procedure.....	53

Introduction

1

Thank you and congratulations on your purchase of a Big Ass Fan, an efficient and cost-effective way to stay cool in the summer and warm in the winter. The revolutionary design of our fans combines the best of both form and function to bring power performance and a sleek look to any setting. More importantly, you have purchased a product that is backed by extensive research, thorough testing, and quality manufacturing. We're ready to answer any questions or comments at 1-877-BIG-FANS or visit our Web site at www.bigassfans.com.

Who we are and what we do

Big Ass Fans has been the preeminent manufacturer of large-diameter, low-speed fans since 1999. With a worldwide presence and located in beautiful Lexington, KY, we research, design, and manufacture the most effective air movement solutions on the market. Our never-ending commitment to quality and innovation keeps us at the leading edge of a burgeoning industry. With an eye to helping customers satisfy their needs, and a strong sense of corporate responsibility to the community, Big Ass Fans has redefined the way business is done.

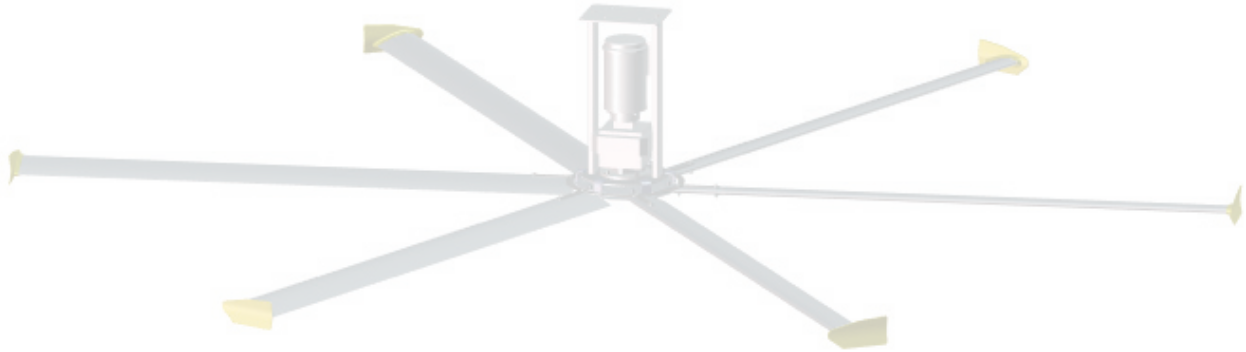

2

Pre-Installation

About this fan

The specifications of the fan depend on the size and model.

Technical specifications

Fan size	Motor size	Gear ratio	Controller rating	Minimum required supply circuit size	Nominal output voltage, 3Φ*	Maximum full load current	Power consumption	Max RPM	Airfoil length	Suggested distance from ceiling
12 ft (3.6 m)	1.0 hp (0.75 kW)	15.8	1.0 hp (0.75 kW)	20 A @ 100–125 V, 1 Φ 15 A @ 200–250 V, 1 Φ 10 A @ 200–250 V, 3 Φ 10 A @ 400–480 V, 3 Φ 10 A @ 575–600 V, 3 Φ	240 V 240 V 240 V 480 V 600 V	11.0 A 5.5 A 3.2 A 1.6 A 1.3 A	600 W	111 RPM	64" (163 cm)	5 ft (1.5 m)
14 ft (4.3 m)	1.0 hp (0.75 kW)	15.8	1.0 hp (0.75 kW)	20 A @ 100–125 V, 1 Φ 15 A @ 200–250 V, 1 Φ 10 A @ 200–250 V, 3 Φ 10 A @ 400–480 V, 3 Φ 10 A @ 575–600 V, 3 Φ	240 V 240 V 240 V 480 V 600 V	11.0 A 5.5 A 3.2 A 1.6 A 1.3 A	660 W	94 RPM	76" (193 cm)	5 ft (1.5 m)
16 ft (4.9 m)	1.5 hp (1.1 kW)	20.0	1.5 hp (1.1 kW)	25 A @ 200–250 V, 1 Φ 15 A @ 200–250 V, 3 Φ 10 A @ 400–480 V, 3 Φ 10 A @ 575–600 V, 3 Φ	240 V 240 V 480 V 600 V	9.8 A 4.9 A 2.4 A 1.9 A	830 W	87 RPM	88" (224 cm)	6 ft (1.8 m)
18 ft (5.5 m)	1.5 hp (1.1 kW)	20.0	1.5 hp (1.1 kW)	25 A @ 200–250 V, 1 Φ 15 A @ 200–250 V, 3 Φ 10 A @ 400–480 V, 3 Φ 10 A @ 575–600 V, 3 Φ	240 V 240 V 480 V 600 V	9.8 A 4.9 A 2.4 A 1.9 A	1180 W	85 RPM	100" (254 cm)	6 ft (1.8 m)
20 ft (6.1 m)	2.0 hp (1.5 kW)	25.1	2.0 hp (1.5 kW)	25 A @ 200–250 V, 1 Φ 15 A @ 200–250 V, 3 Φ 10 A @ 400–480 V, 3 Φ 10 A @ 575–600 V, 3 Φ	240 V 240 V 480 V 600 V	12.4 A 6.2 A 3.2 A 2.6 A	1130 W	69 RPM	112" (284 cm)	7 ft (2.1 m)
24 ft (7.3 m)	2.0 hp (1.5 kW)	28.3	2.0 hp (1.5 kW)	25 A @ 200–250 V, 1 Φ 15 A @ 200–250 V, 3 Φ 10 A @ 400–480 V, 3 Φ 10 A @ 575–600 V, 3 Φ	240 V 240 V 480 V 600 V	12.4 A 6.2 A 3.2 A 2.6 A	1400 W	61 RPM	136" (345 cm)	7 ft (2.1 m)

* Output voltage will not exceed Input voltage, with the exception of 120 V models. All controllers produce 3 Φ output power, regardless of input phase.

Motor

- 1 to 2 hp motor
- NEMA Design B
- 208/230/460 Volts AC
- 1725 RPM
- 60 Hz, 3-phase
- Insulation: Class F
- Rating: 40° C Ambient–Continuous

Reduction gear

- Concentric Helical Gear Reducer
- Gear Hardened to 58-62 Rockwell C
- Precision finished for low noise and long service life
- Double seals keep oil in and contaminants out
- Lubricated for life with synthetic oil

What's in the box

If you ordered multiple fans, be sure to keep the components of each fan together. The fans each have differently rated components that are not interchangeable.

The fan is shipped in multiple boxes. The large box contains the main fan unit, upper yoke (with beam clips and spacers), lower yoke, extension tube (if 3 ft or shorter) with attached safety cable, winglets, control panel, and mounting hardware. The smaller box contains the airfoils. If the extension tube is 4 ft or longer, it will also be shipped in a separate box.

Note: Dashed lines indicate internal boxes. Drawings below are not to scale.

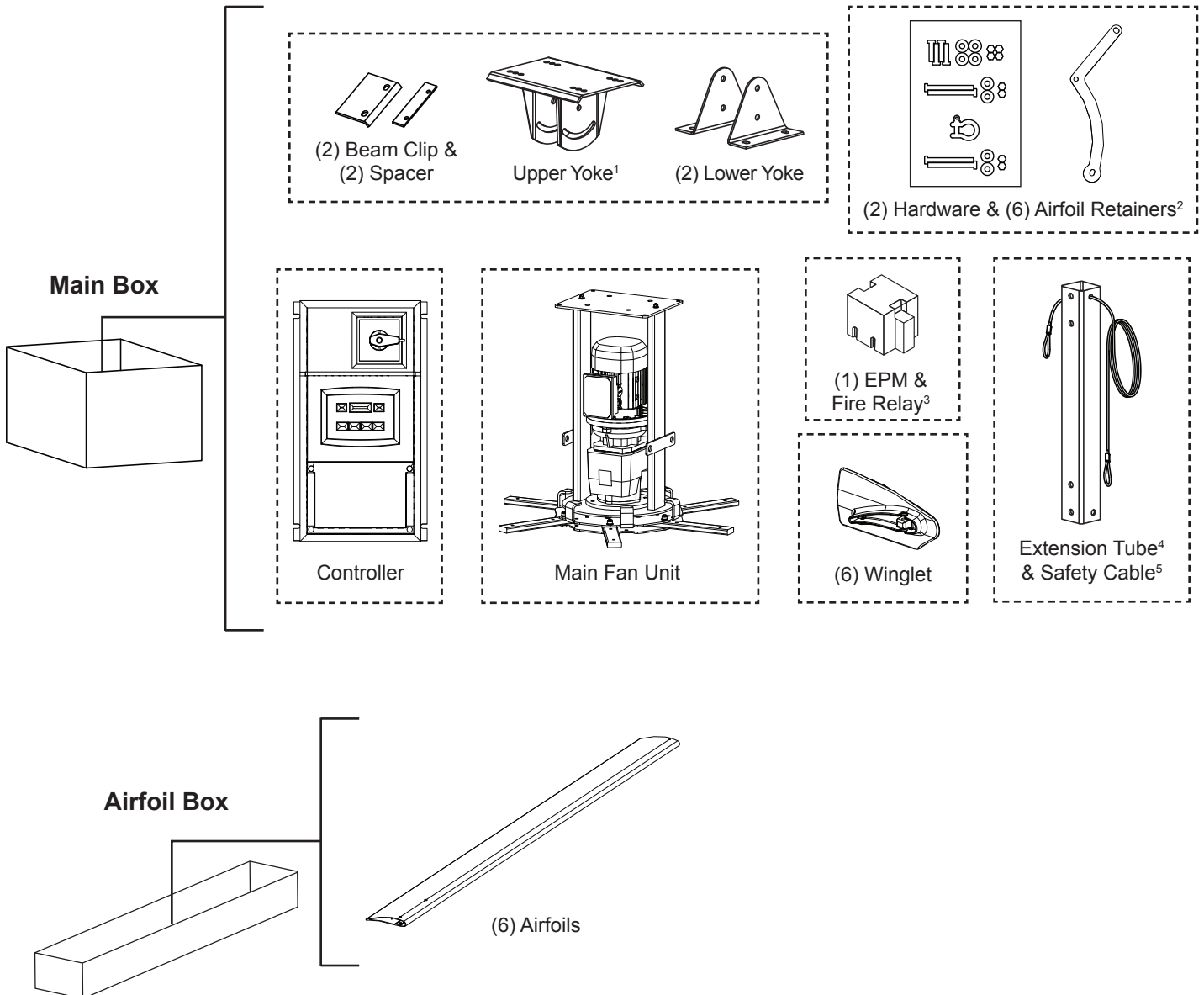

1. The upper yoke may differ from the illustration. Confirm you have the appropriate upper yoke for your roof pitch (page 5).
2. This installation guide is also packaged in the box with the hardware and airfoil retainers. If your order includes yokes and an extension tube, square washers will also be packaged in this box. Square washers are needed only if you are mounting the fan to angle irons. The number of square washers needed depends on the number of angle irons that will be used. Winglet hardware is packed in the winglet box. Guy wires (if ordered) are bagged separately in the main box.
3. Fire relay not shown.
4. The extension tube is only included if ordered. If extension tube is 4 ft or longer, it will be shipped in a separate box.
5. Safety cable is attached to extension tube or packed separately if extension tube was not ordered.





4

Pre-Installation (cont.)

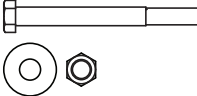
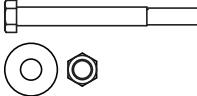

Parts included

Note: The drawings below are not to scale. Note: No hardware substitutions are acceptable.

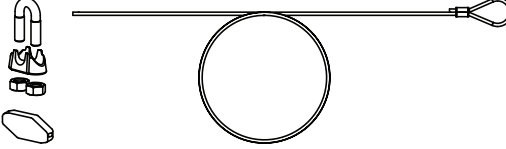

Hardware¹

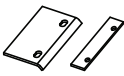
			
Upper Yoke Hardware (4) 1/2-13 x 2" GR 8 Bolt (8) 1/2" Flat Washer (4) 1/2-13 Nylock Nut	Extension Tube Hardware (2) 1/2-13 x 4-1/2" GR 8 Bolt (4) 1/2" Flat Washer (2) 1/2-13 Nylock Nut	Lower Yoke Hardware (2) 1/2-13 x 4-1/2" GR 8 Bolt (4) 1/2" Flat Washer (2) 1/2-13 Nylock Nut	Main Fan Unit Hardware (4) 1/2-13 x 1 3/4" GR 8 Bolt (8) 1/2" Flat Washer (4) 1/2-13 Nylock Nut
			
Winglet Hardware (6) 10-24 x 1/2" Bolt (6) 10-24 x 3/4" Barrel	Airfoil Hardware (12) 5/16-18 x 2" GR 8 Bolt (24) 5/16" Flat Washer (12) 5/16-18 Nylock Nut	Guy Wire Hardware² (8) Locking Carabiner (4) 1/4" Beam Clip (4) 1/4-20 x 1" Eyebolt (4) 1/4-20 Hex Nut	
			(4) Gripple® (4) Guy Wire (8) Wire Rope Clip

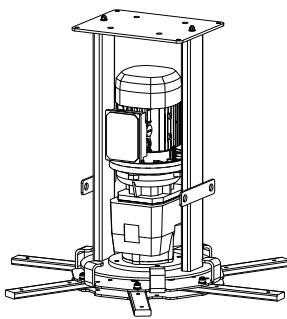
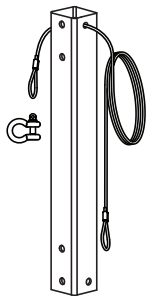
Mounting

		
(2) Beam Clip & (2) Spacer	Upper Yoke ³	(2) Lower Yoke
		
Main Fan Unit		Extension Tube, Safety Cable ⁴ , & Shackle ⁵

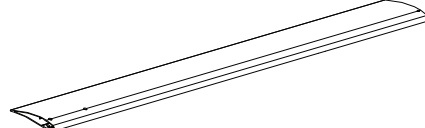
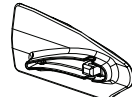
Airfoils

(6) Airfoils

(6) Powerfoil® Winglets

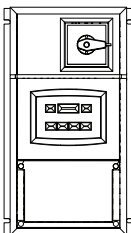
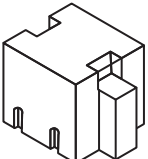
(6) Airfoil Retainers

Electrical

	
Wall Controller	EPM & Fire Relay ⁶

1. If your order includes yokes and an extension tube, square washers will be included in your hardware. Square washers are needed only if you are mounting the fan to angle irons. The number of square washers needed depends on the number of angle irons that will be used.
2. Guy wires are designed to constrain fan's lateral movement and are only included in some fan packages. Big Ass Fans recommends using guy wires if the fan's extension tube is 4 ft or longer, if the fan is exposed to high winds or similar conditions, or if the fan is close to any building fixtures. Guy Wire Hardware is bagged separately from hardware boards.
3. The upper yoke may differ from the illustration. Confirm you have the appropriate upper yoke for your roof pitch (page 5).
4. Safety cable is attached to extension tube or packed separately if extension tube was not ordered.
5. Shackle included on hardware boards.
6. Fire Relay not shown. If multiple fans are to be installed, ensure to install the exact EPM included in the fan's packaging. *EPMs are not interchangeable!*

Tools needed

Big Ass Fans recommends gathering the following tools prior to beginning installation.

Mechanical installation
Standard wrench set
Standard socket set and ratchet
Torque wrench capable of 40 ft·lb (54.2 N·m)
Phillips and flat head screwdriver
Standard allen wrench set

Electrical installation
Phillips and flat head screwdriver
1/4" nut driver
5/16" nut driver
Pair of #10 to #14 AWG strippers
Pair of medium channel locks
Multimeter

Understanding roof pitch

Before beginning installation, confirm that you have the appropriate mount for your roof pitch.

To ensure the fan is properly mounted, the fan must always hang plumb to the ground and the yoke must be installed using the bolt holes at the widest locations possible. To accommodate building structures on which the standard upper yoke does not allow the fan to properly orient itself, the 90-Degree Offset mount should be purchased.

The example below shows one situation in which the 90-Degree Offset mount must be used so that the fan hangs plumb to the ground and the widest stance for the upper yoke is ensured. If you are uncertain of your roof pitch or do not have the correct mount to properly hang your fan, consult a structural engineer or contact Big Ass Fans Customer Service.

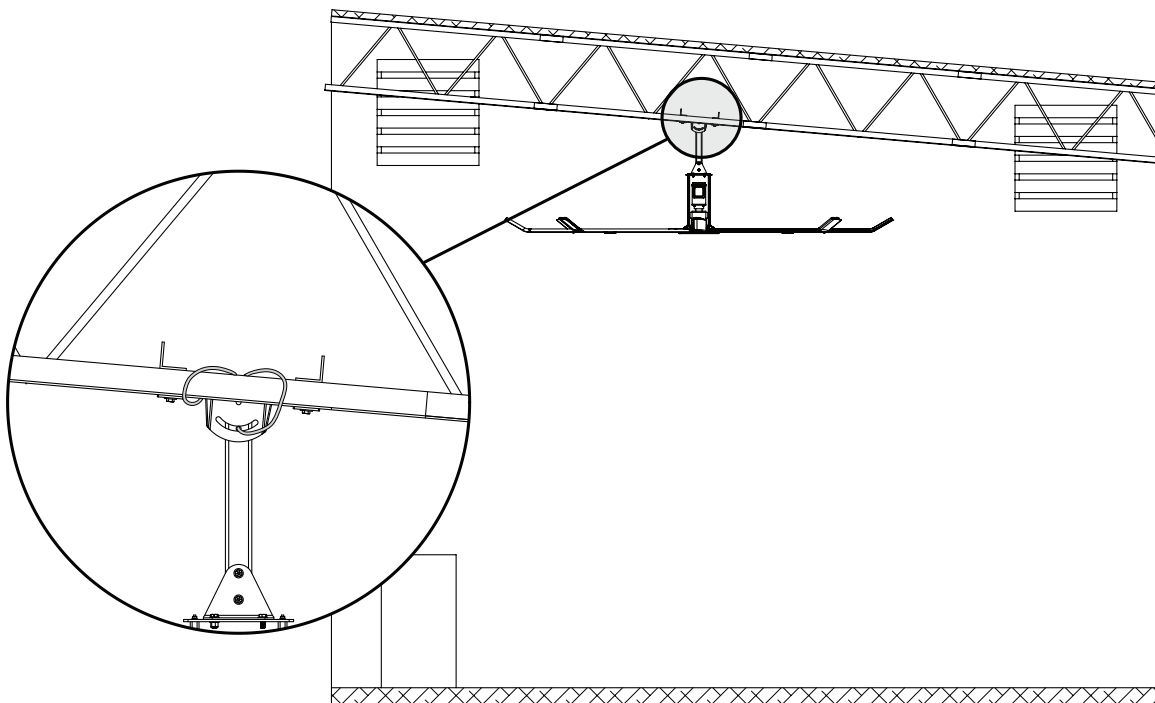

Standard Upper Yoke

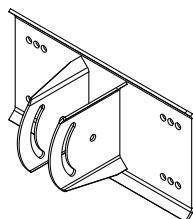

90-Degree Offset Mount

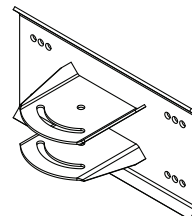

6

Pre-Installation (cont.)

Fan diagram

- A. Safety Cable.** A redundant safety feature that secures the fan to the mounting structure.
- B. Upper Yoke.** Secures the fan to the mounting structure and allows the fan to adjust its center of gravity. *Note: The upper yoke may differ from the illustration below.*
- C. Extension Tube.** Extends the fan from the ceiling.
- D. Lower Yoke.** Connects main fan unit to the extension tube.
- E. Motor.** See page 2 for technical specifications.
- F. Hub.** Secures the airfoils to the gearbox.
- G. Airfoil.** Provides air movement. The unique, patented design provides efficiency and effective air movement.
- H. Winglet.** Improves the efficiency of the fan.

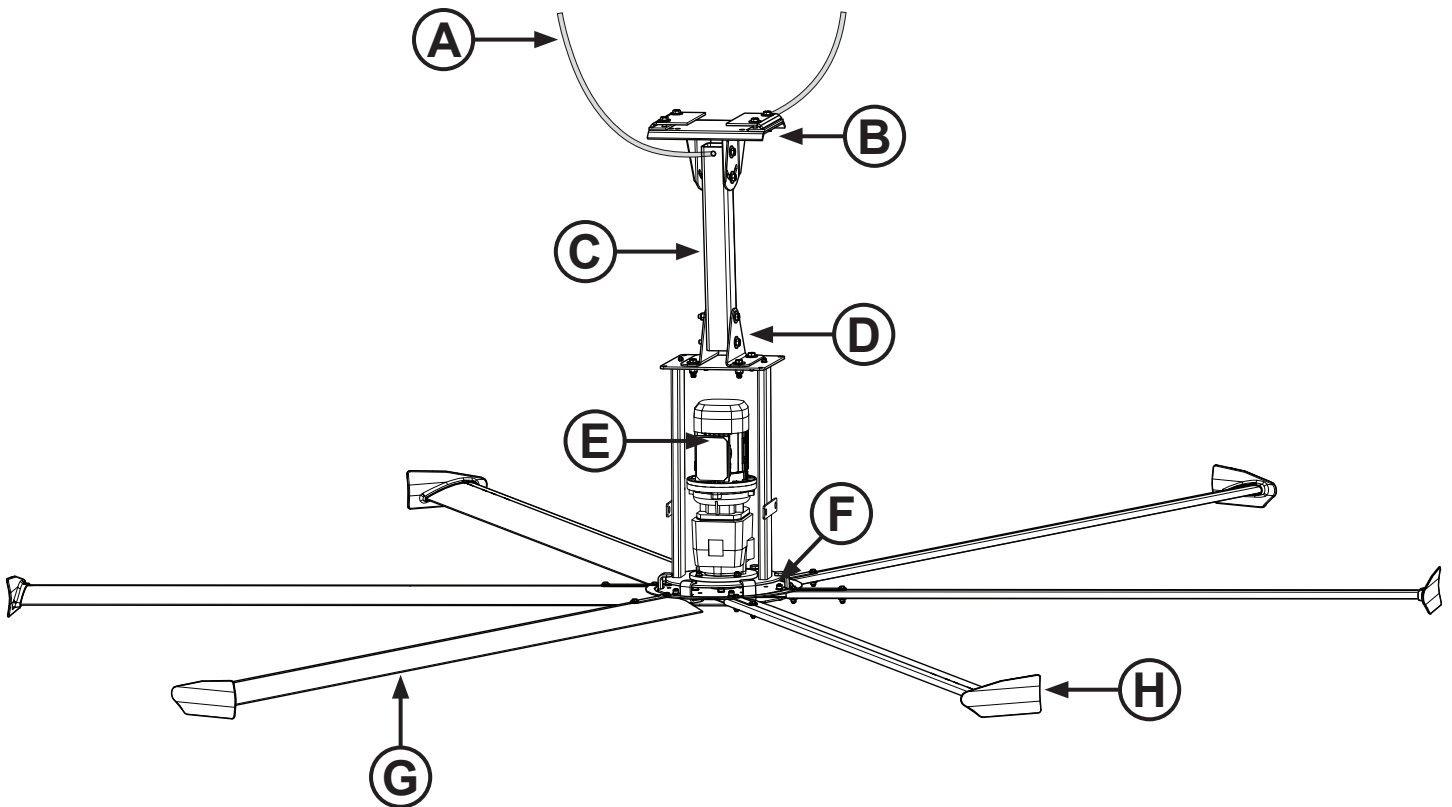

Preparing the work site

Before beginning installation, review the mechanical and electrical installation guidelines below.

Mechanical installation

- A 24-ft (7.3-m) Basic 6® fan (largest model) with a 1-ft extension tube weighs, at maximum, 241 lbs (109 kg). A suitable means for lifting the weight of the fan, such as a scissor lift, and at least two installation personnel will be required.
- Big Ass Fans can only be hung from an I-beam or angle irons. For specific requirements, see the Mechanical Installation section in this guide. Do not mount the fan to single purlins, trusses, or bar joists. Consult a structural engineer for installation methods not covered in this manual.

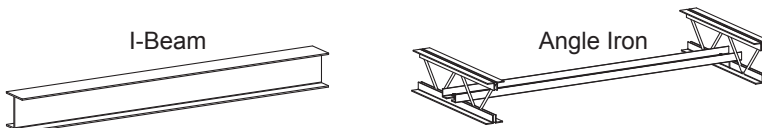

- The mounting structure must be able to withstand the torque forces generated by the fan. A 24-ft fan generates nearly 300 ft-lb (406.7 N·m) of torque during operation.
- Fans mounted on fabricated I-beams, which are common in steel buildings, could cause the beam to flex and the fan to move significantly during operation. If this flexing causes a clearance problem we suggest installing I-Beam Stabilizer kit.
- If the fan's extension tube is 4 ft (1.2 m) or longer or if the mounting structure requires it, the fan's lateral movement must be secured using guy wires. If the fan is close to any building fixtures it is recommended to secure the fan with guy wires as a safety measure.
- Adhere to the safety requirements in the table below when selecting the fan location.

Safety requirement	Minimum distances
Clearance	≥2 ft from all fan parts. The fan installation area must be free of obstructions such as lights, cables, sprinklers, or other building structure. See the table on page 2 for recommended minimum ceiling clearances.
Blade height	≥10 ft above the floor
HVAC equipment	≥1x fan diameter if at same level or above diffuser. ≥2x fan diameter if below diffuser. Refer to the illustration below.
Fan spacing	2.5x fan diameter, center-to-center
Radiant/IR heaters	See the manufacturer's requirements for the minimum clearance to combustibles.

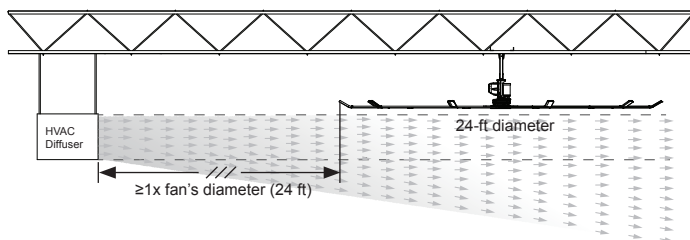

The fan is located at or above the HVAC discharge or intake.

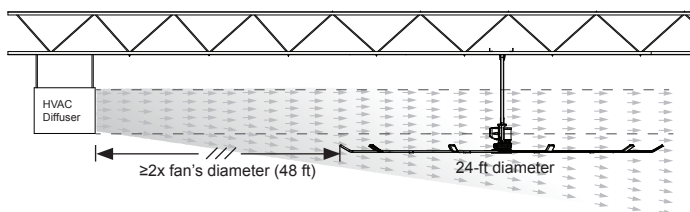

The fan is located below the HVAC discharge or intake.

Electrical installation

- To reduce the risk of electric shock, wiring should be performed by a qualified electrician! Incorrect assembly can cause electric shock or damage the motor and the controller!
- The installation of a Big Ass Fan must be in accordance with the National Electrical Code, ANSI/NFPA 70-2011, and all local codes.
- Refer to the Electrical Installation section in this manual for acceptable cable types, conduit, and other electrical requirements.
- Controller output/motor input leads cannot share a conduit with any other controller's AC supply feed.
- If you are installing an onboard variable frequency drive (VFD), route the power wiring to the location where the fan will be mounted.

8

Pre-Installation (cont.)

Understanding airflow patterns

Airflow in an open area

The airflow moves from the fan toward the floor. Once airflow hits the floor, it moves outward in all directions. The deflection of air off the floor is called a "floor jet."

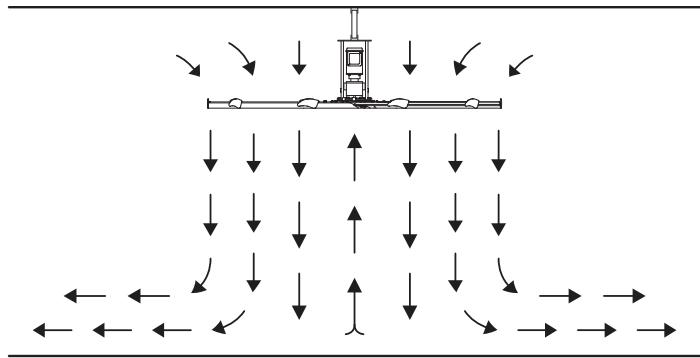

Airflow in an enclosed area

The floor jet radiates outward until it reaches the walls, which deflect the jet upward. After it hits the ceiling, the upward flow is directed inward to the low pressure area above the fan where it is then pulled down toward the floor. This creates a convection-like air current that gathers momentum. Once this current is established, the fan begins to move air outside of the current, escalating its cooling effects.

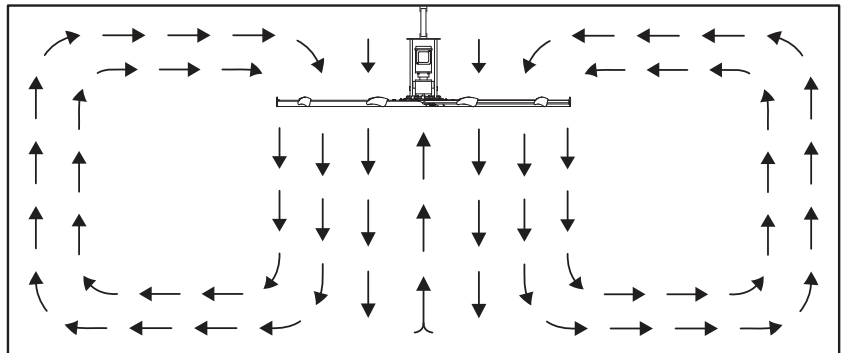

Airflow with multiple fans

Where there are multiple fans appropriately spaced, the expanding jets of adjacent fans meet to create a pressure zone. The pressure zone acts like a wall, causing each fan to behave like a single enclosed fan. Typically, a single fan's performance will increase when working in conjunction with other fans.

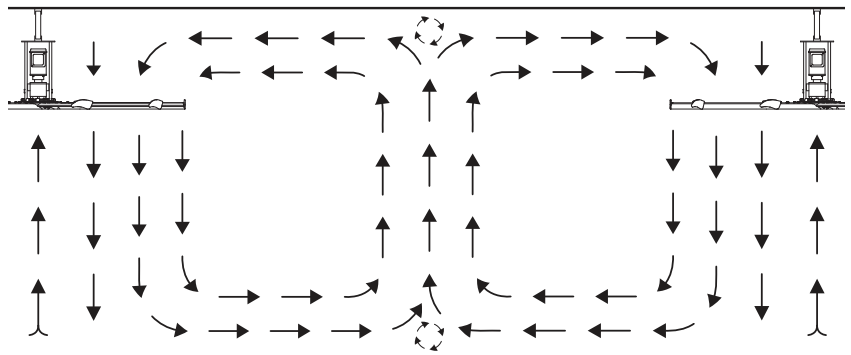

Airflow with streamlined obstruction

Obstructions on the floor tend to block the horizontally moving air. Thin or streamlined obstructions do not block much airflow, regardless of size. The air tends to flow smoothly around these obstructions, losing little momentum, and leaving only a small stagnant area behind the obstruction.

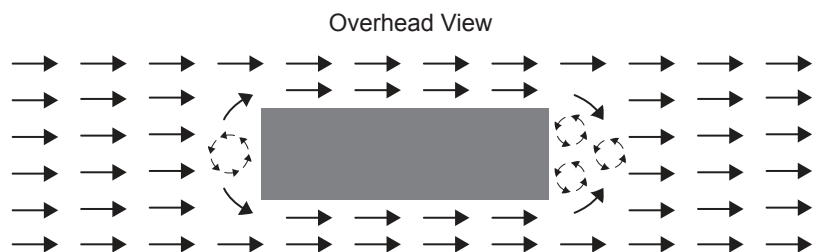

Airflow with wide, blunt obstruction

A wide, blunt, or flat-faced obstruction forces the air to change direction, turning upward and outward. There is a stagnant area behind these obstructions that is wider and higher than the obstructions themselves.

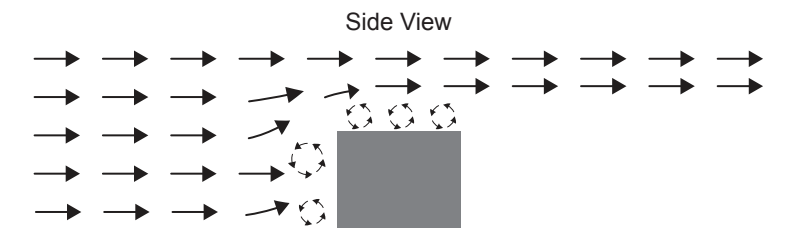

Airflow tips

Below are some techniques that make a dramatic difference in congested areas of your facility. Treat air like water, and scoop, direct, and channel it to where it is needed most.

- Make sure people are not hidden behind structures that would block airflow. This may seem obvious, but work areas are routinely blocked by shelving, crates, and machinery.
- Position large obstructions so that their smallest profiles are perpendicular to the direction of air movement. For example, a sheet metal press brake might have five times the frontal area if it is facing the airflow rather than if it is turned sideways.
- Wherever possible, position welding curtains, partitions, sheet materials, etc., to scoop air into the work area rather than deflect it.
- Take advantage of the air moving near the floor by creating ground level openings in your work area. It is better to have a work area blocked by materials stacked to the ceiling with an opening below than to have low stacks 3 ft (0.9 m) to 6 ft (1.8 m) high sitting on the floor.

10

Mounting Structure: I-Beam

Big Ass Fans can only be hung from an I-beam or bar joists. See page 12 for bar joist mounting instructions. Consult a structural engineer for installation methods not covered in this manual.

- ⚠ **WARNING:** The fan should not be installed unless the structure on which the fan is to be mounted is of sound construction, undamaged, and capable of supporting the loads of the fan and its method of mounting. A structural engineer should verify that the structure is adequate prior to fan installation. Verifying the stability of the mounting structure is the sole responsibility of the customer and/or end user, and Big Ass Fans hereby expressly disclaims any liability arising therefrom, or arising from the use of any materials or hardware other than those supplied by Big Ass Fans or otherwise specified in these installation instructions.
- ⚠ **CAUTION:** It is not recommended to mount a Big Ass Fan to a fabricated I-beam. Do not direct mount the fan to an I-beam. The I-beam on which the fan will mount must be part of the existing building structure.
- ⚠ **CAUTION:** Install the spacers only if the thickness of the I-beam flange exceeds 3/8" (1 cm). The mounting holes on the spacer are closer to one edge than the other. Make sure this edge of the spacer is facing the I-beam.
- ⚠ **CAUTION:** Before beginning installation, confirm that you have the appropriate mount for your roof pitch.
- ⚠ **WARNING:** Ensure there are no persons below the fan unit during installation!

1. Measure I-beam width

Measure the flange width of the I-beam from which the fan will be hung. Select the upper yoke mounting holes that match the flange width of the I-beam.

Small Upper Yoke 13-3/4" x 10" (349 mm x 258 mm)			Large Upper Yoke 18-1/2" x 10" (470 mm x 258 mm)	
I-beam flange width	Upper yoke mounting holes		I-beam flange width	Upper yoke mounting holes
5" (127 mm) to 6-5/8" (168 mm)	Inner holes		9-7/8" (250 mm) to 11-3/8" (289 mm)	Inner holes
>6-5/8" (168 mm) to 8-1/4" (210 mm)	Middle holes		>11-3/8" (289 mm) to 13" (330 mm)	Middle holes
>8-1/4" (210 mm) to 9-7/8" (250 mm)	Outer holes		>13" (330 mm) to 14-5/8" (371 mm)	Outer holes

2. Attach upper yoke (to I-beam)

Secure the upper yoke to the I-beam with the Beam Clip Hardware as shown.

Note: Spacers are only used if the beam flange exceeds 3/8" (1 cm).

Tighten the bolts to **40 ft·lb (54.2 N·m)** using a torque wrench and 3/4" socket.

Upper Yoke Hardware (BAF-Supplied):

- a. (4) 1/2-13 x 2" GR 8 Bolt
- b. (8) 1/2" Flat Washer
- c. (4) 1/2-13 Nylock Nut
- d. (2) Beam Clip
- e. (2) Spacer

Proceed to "Hanging the Fan" (page 18).

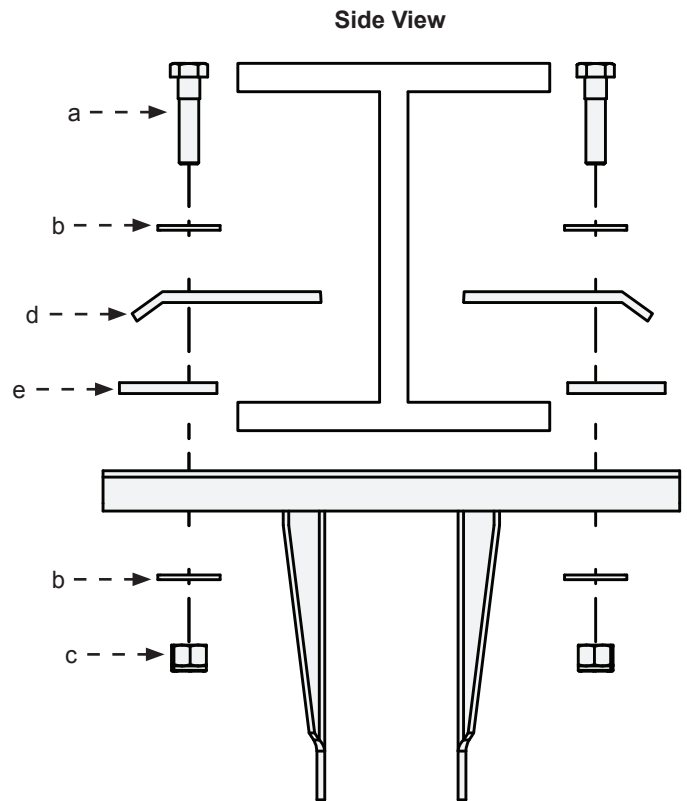
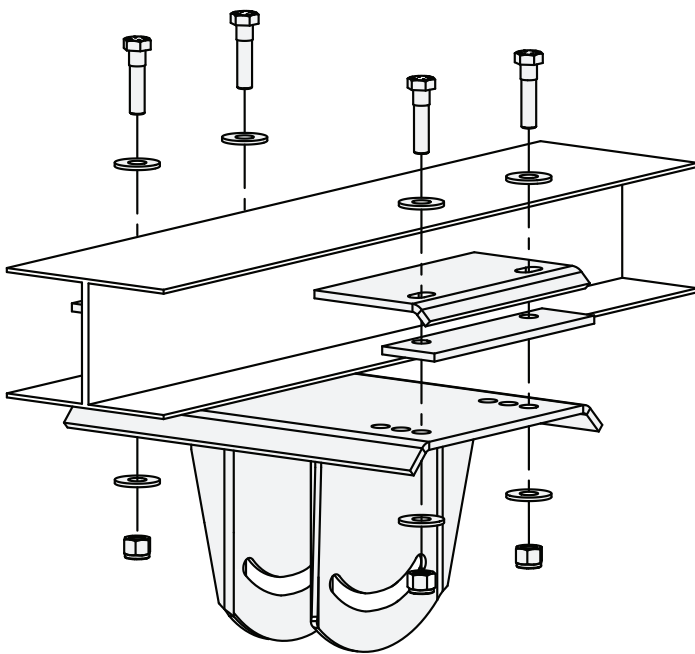

12

Mounting Structure: Bar Joists

Big Ass Fans can only be hung from an I-beam or bar joists. See page 10 for I-beam mounting instructions. Consult a structural engineer for installation methods not covered in this manual.

- ⚠ WARNING:** The fan should not be installed unless the structure on which the fan is to be mounted is of sound construction, undamaged, and capable of supporting the loads of the fan and its method of mounting. A structural engineer should verify that the structure is adequate prior to fan installation. Verifying the stability of the mounting structure is the sole responsibility of the customer and/or end user, and Big Ass Fans hereby expressly disclaims any liability arising therefrom, or arising from the use of any materials or hardware other than those supplied by Big Ass Fans or otherwise specified in these installation instructions.
- ⚠ WARNING:** Never use beam clips when mounting fans to angle irons! Beam clips are intended for I-beam installations.
- ⚠ CAUTION:** Do not install the fan from a single purlin, truss, or bar joist.
- ⚠ CAUTION:** Unsupported angle iron spans should not exceed 12 ft (3.7 m).
- ⚠ CAUTION:** The angle irons must be fastened to the roof structure at each end.

1. Select proper angle irons

Follow the table below when selecting angle irons for fan installation. *Note: Angle irons and angle iron hardware are not included with the fan.*

Angle iron span (between mounting points)	Minimum angle iron dimensions (W x H x T)	Number of angle irons needed
6 ft (1.8 m) or less	2.5" (6.4 cm) x 2.5" (6.4 cm) x 0.25" (0.6 cm)	2
6 ft (1.8 m) to 8 ft (2.4 m)	3" (7.6 cm) x 3" (7.6 cm) x 0.25" (0.6 cm)	2
8 ft (2.4 m) to 12 ft (3.7 m)	3" (7.6 cm) x 3" (7.6 cm) x 0.25" (0.6 cm)	4*

*Two pairs of angle irons. Pairs should be placed back to back and fastened in center (see step 3).

Angle Iron Side View
(see table for dimensions)

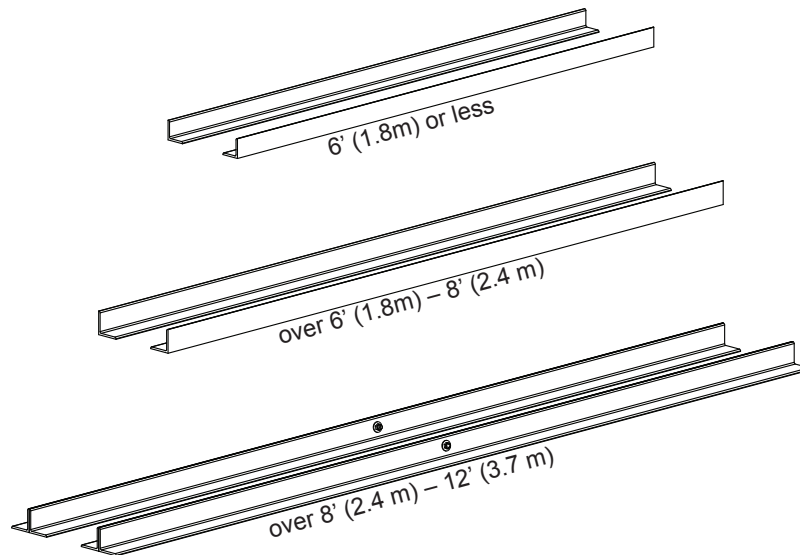
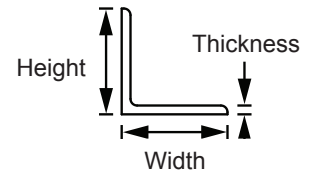

2. Pre-drill angle irons

Before drilling the angle irons, confirm that you have the appropriate mount to accommodate the roof pitch of your mounting structure.

Drill two $\text{Ø}9/16''$ (1.4 cm) holes exactly $5\text{-}3/8''$ (13.7 cm) apart in the centers of two angle irons.

Measure the distance between the mounting points of the roof structure that the angle irons will span. Measure the same distance on the angle irons and drill $\text{Ø}9/16''$ (1.4 cm) holes through each end of the angle irons. Drill holes in two angle irons if the span is 8 ft (2.4 m) or less. Drill holes in 4 angle irons if span is greater than 8 ft (2.4 m).

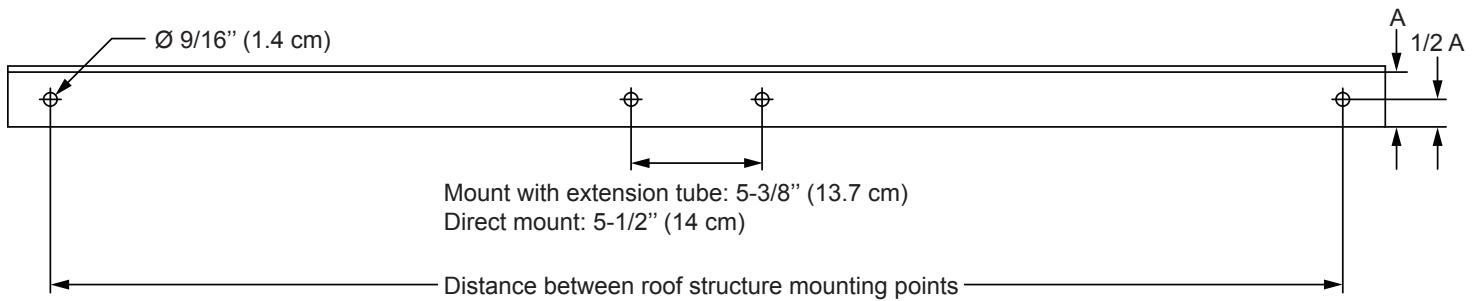

3. Fasten angle irons together (if span is longer than 8 ft [2.4 m])

If the angle iron span is 8 ft (2.4 m) or less, skip step 3 and proceed to step 4a.

If the angle iron span is longer than 8 ft (2.4 m), it is necessary to use double angle irons.

Locate the center of the angle iron length. Drill $\text{Ø}9/16''$ (1.4 cm) hole through the center of the vertical wall of the angle iron. Drill a total of four angle irons.

Place two drilled angle irons back to back. Fasten the angle irons together with customer-supplied $\text{Ø}1/2\text{-}13$ Grade 8 hardware and tighten the bolts to **40 ft·lb (54.2 N·m)** using a torque wrench and $3/4''$ socket.

Repeat this step for the remaining two angle irons.

Proceed to step 4b.

Grade 8 Hardware (Customer-Supplied):

- a. (2) $1/2\text{-}13$ Bolt
- b. (4) $1/2''$ Washers
- c. (2) $1/2\text{-}13$ Nylock Nut

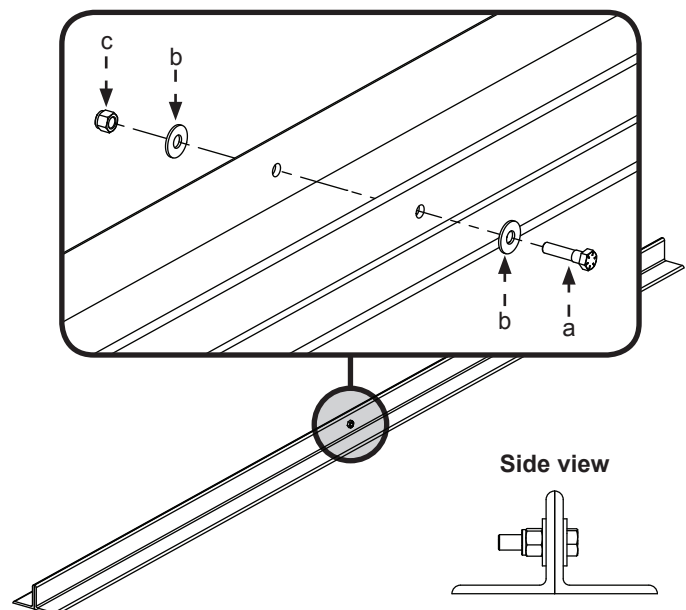

14

Mounting Structure: Bar Joists (cont.)

4a. Fasten single angle irons to roof structure mounting points

If the angle iron span is greater than 8 ft (2.4 m) and requires double angle irons, proceed to step 4b.

Fasten the angle irons to the roof structure mounting points at each end with customer-supplied Grade 8 hardware as shown. *Do not tighten the hardware until the upper yoke has been mounted to the angle irons* (step 5). Big Ass Fans recommends orienting the angle irons so that the horizontal legs are facing each other. Refer to the illustration below.

Proceed to step 5.

Grade 8 Hardware (Customer-Supplied):

- a. (4) 1/2-13 Bolt
- b. (8) 1/2" Washer
- c. (4) 3" Square Washer (BAF-Supplied; see diagram)
- d. (4) 1/2-13 Nylock Nut

Square Washer

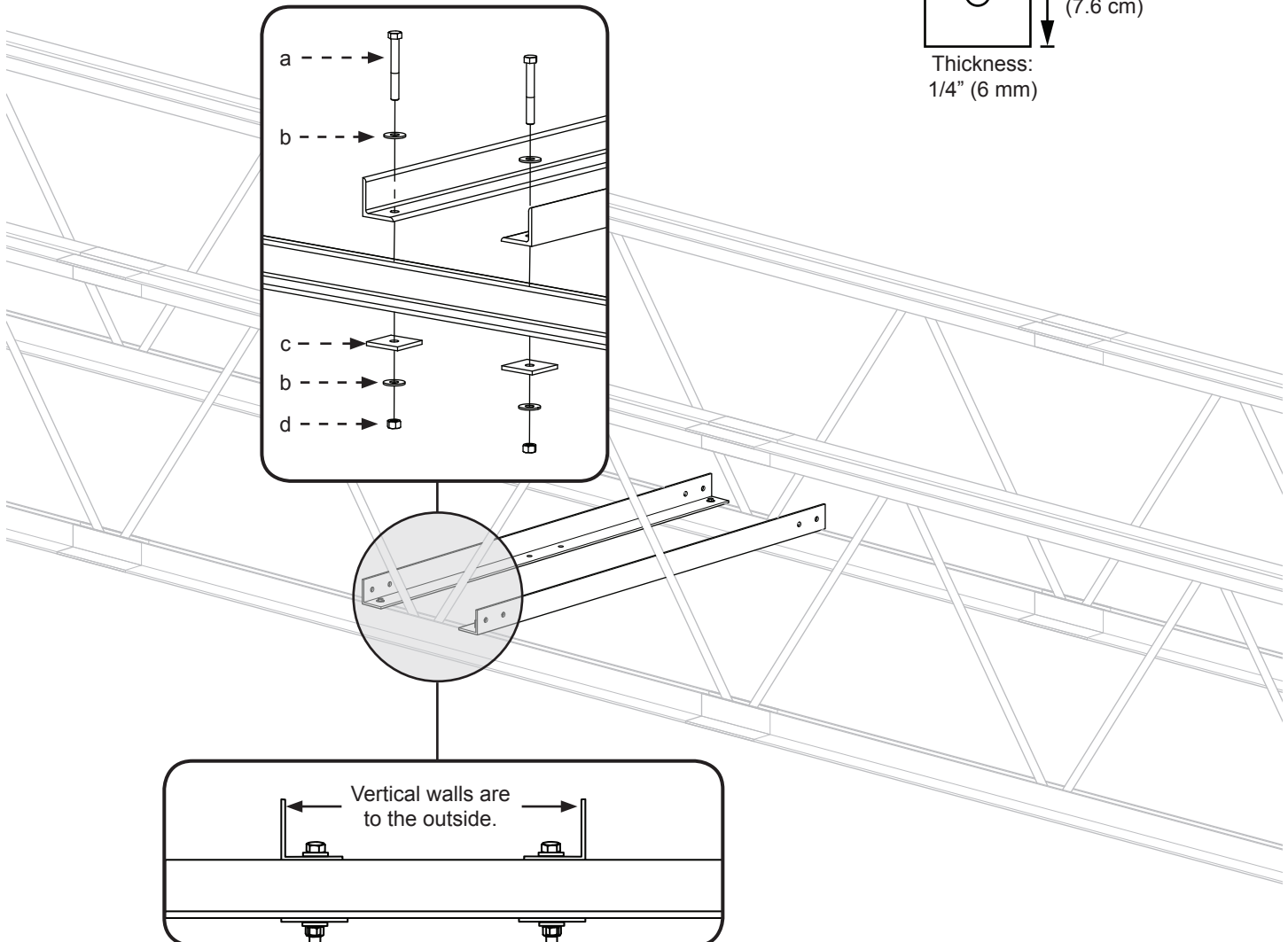
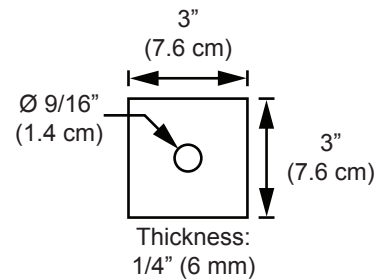

Note: Ensure the angle irons are oriented as shown.

4b. Fasten double angle irons to roof structure mounting points

Fasten the angle irons to the roof structure mounting points at each end with customer-supplied Grade 8 hardware as shown. The angle irons with fan mounting holes should be positioned on the inside, facing each other. *Do not tighten the hardware until the upper yoke has been mounted to the angle irons.*

Grade 8 Hardware (Customer-Supplied):

- a. (8) 1/2-13 Bolt
- b. (16) 1/2" Washer
- c. (8) 3" Square Washer (BAF-Supplied; see diagram)
- d. (8) 1/2-13 Nylock Nut

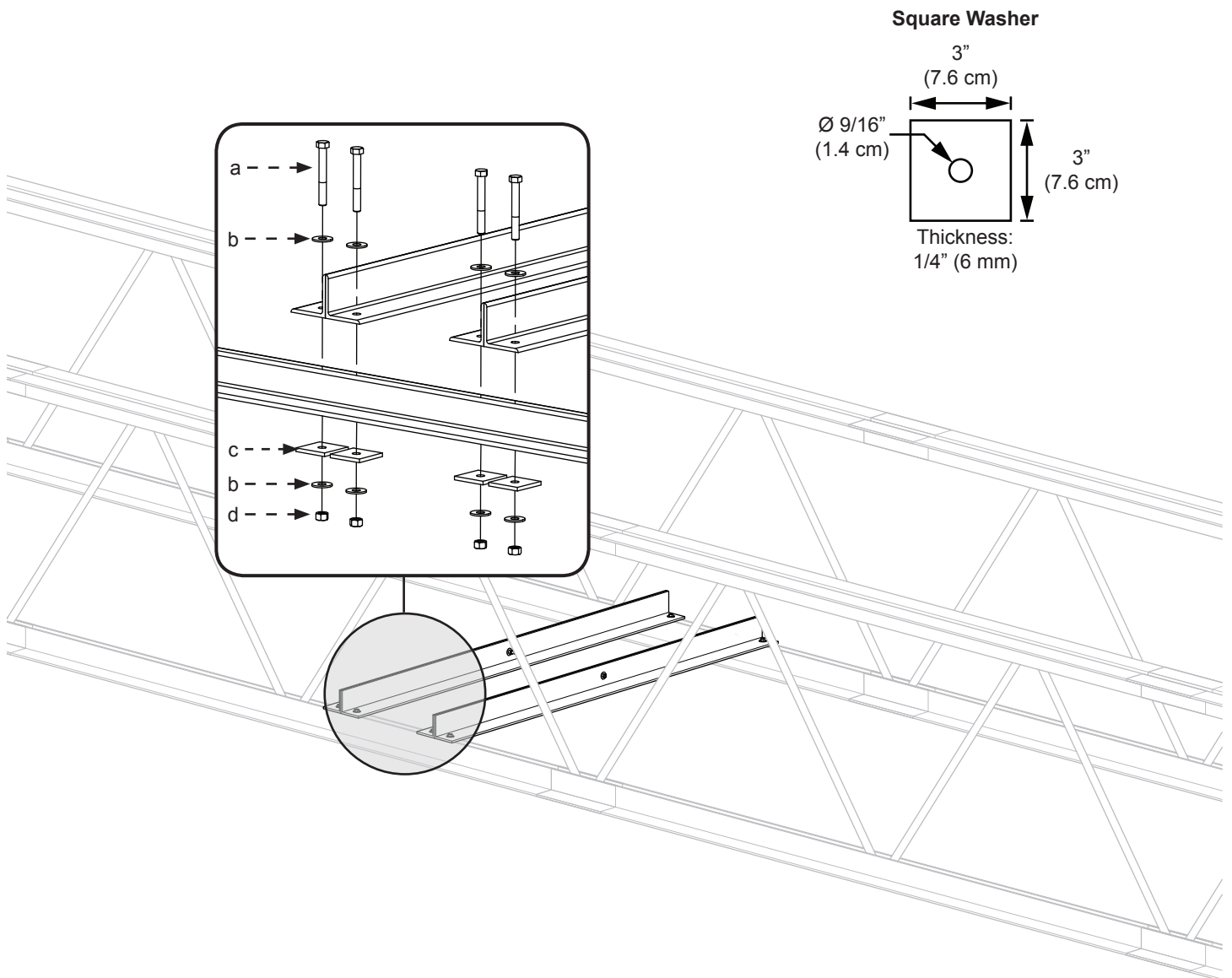

5a. Attach upper yoke (to angle irons)

If the fan will be directly mounted to the angle irons, skip this step and proceed to step 5b.

Secure the upper yoke directly to the angle irons with the Upper Yoke Hardware as shown. The angle irons should be aligned with the outermost holes of the upper yoke. Consult the diagrams below for distances between the angle irons.

Tighten the bolts to **40 ft·lb (54.2 N·m)** using a torque wrench and 3/4" socket. After attaching the upper yoke to the angle irons, tighten all the bolts securing the angle irons to the roof structure to **40 ft·lb (54.2 N·m)**.

Proceed to "Hanging the Fan" (page 18).

Upper Yoke Hardware (BAF-Supplied):

- (4) 1/2"-13 x 2" GR 8 Bolt
- (8) 1/2" Flat Washer
- (4) 1/2-13 Nylock Nut

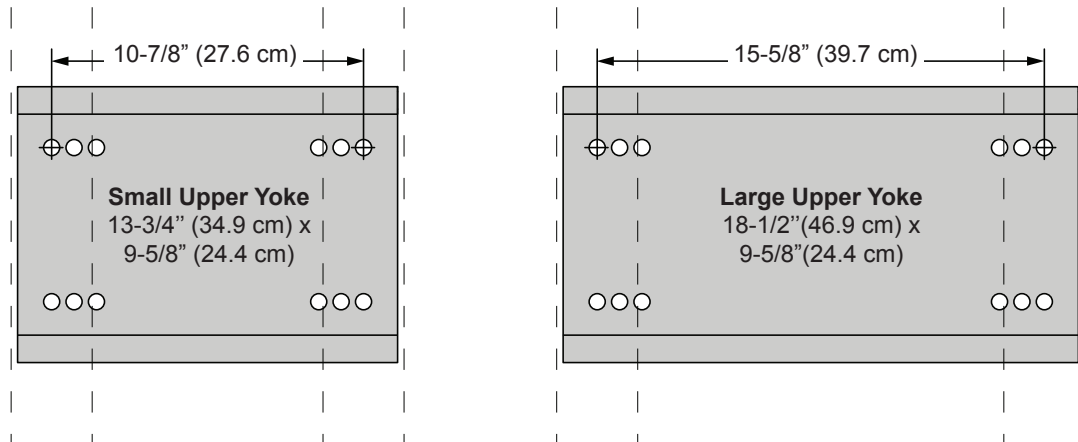

Note: Dashed lines represent angle irons.

The angle irons should be aligned with the outermost holes on the upper yoke. Do not use beam clips on angle irons!

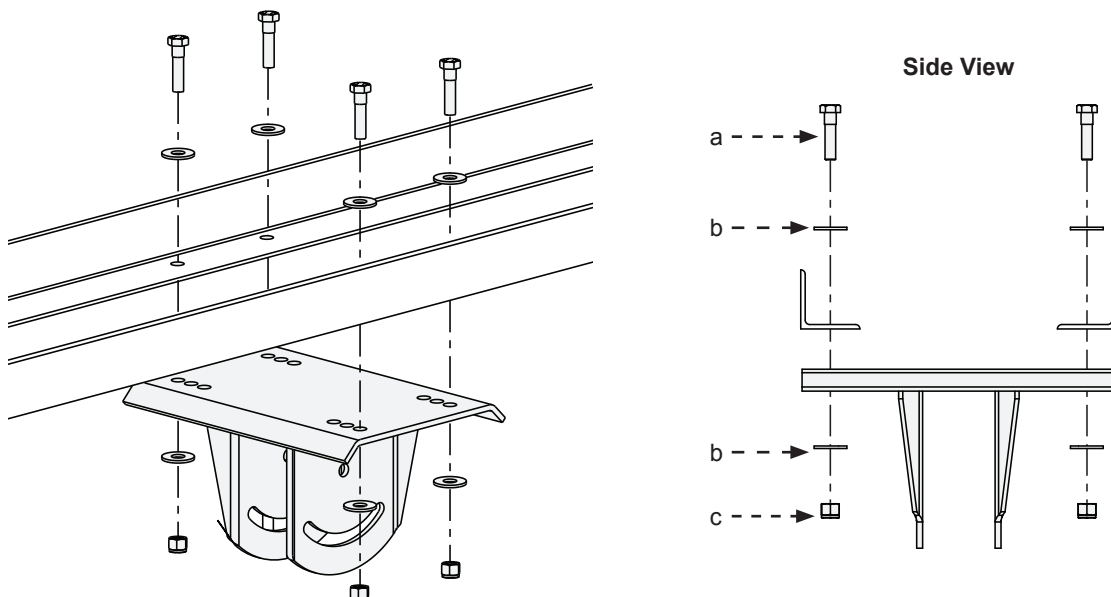

5b. Attach main fan unit (to angle irons)

⚠ CAUTION: The main fan unit is heavy. Use caution when raising it. A 24-ft (7.3-m) Basic 6® fan weighs, at maximum, 415 lbs (188 kg). A suitable means for lifting the weight of the fan, such as a scissor lift, and at least two (2) installation personnel will be required.

Attach the main fan unit directly to the angle irons with the Main Fan Unit Hardware as shown. Consult the diagram below for distances between the angle irons. *Note: The fan can only be directly mounted to angle irons. Do not directly mount the fan to an I-beam.*

Tighten the bolts to **40 ft-lb (54.2 N·m)** using a torque wrench and 3/4" socket. After attaching the main fan unit to the angle irons, tighten all the bolts securing the angle irons to the roof structure to **40 ft-lb (54.2 N·m)** using a torque wrench and 3/4" socket.

Proceed to "Secure Safety Cable" (page 18).

Main Fan Unit Hardware (BAF-Supplied):

- (4) 1/2-13 x 1 3/4" GR 8 Bolt
- (8) 1/2" Flat Washer
- (4) 1/2-13 Nylock Nut

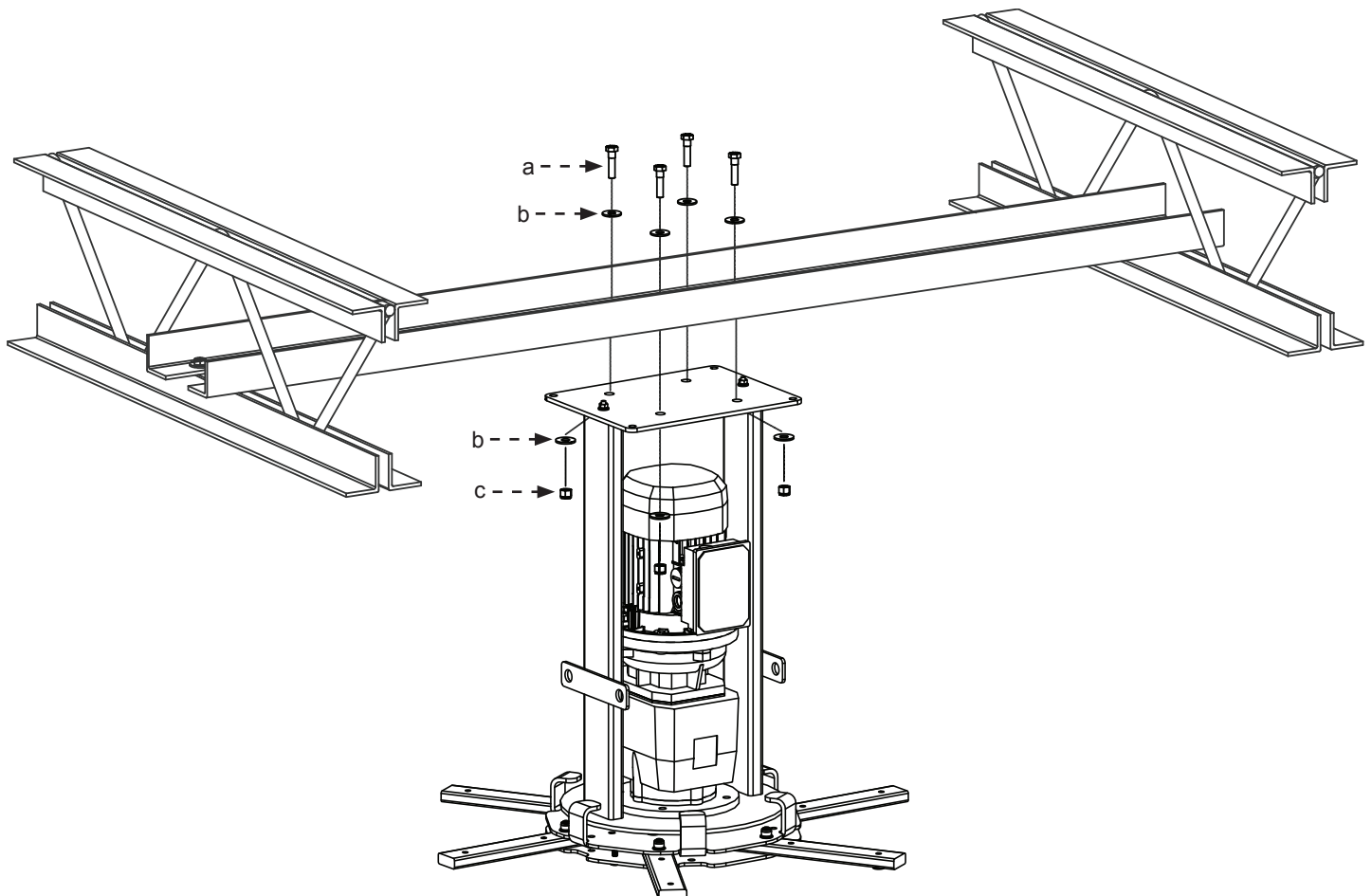
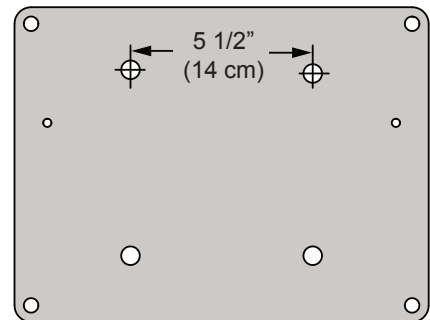

18

Hanging the Fan

1. Attach extension tube (to upper yoke)

Fasten the extension tube to the upper yoke with the Extension Tube Hardware as shown. Ensure the extension tube is hanging plumb to the ground, and then tighten the hardware so that it is snug, but not fully tightened.

Note: If the mounting structure requires a non-standard length of extension tube, see "Cutting the Extension Tube" on page 43.

Extension Tube Hardware (BAF-Supplied):

- a. (2) 1/2-13 x 4-1/2" GR 8 Bolt
- b. (4) 1/2" Flat Washer
- c. (2) 1/2-13 Nylock Nut

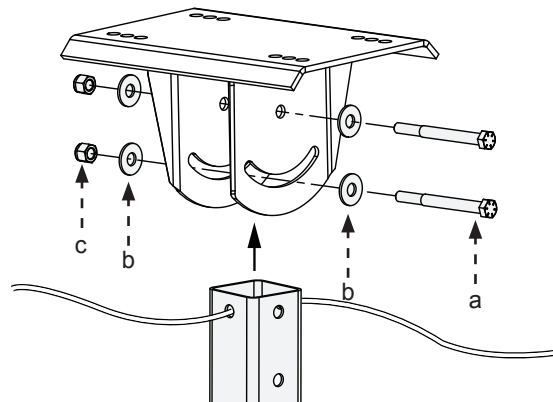

2. Secure safety cable

The safety cable is a crucial part of the fan and must be installed correctly. If you have questions, call Customer Service for assistance.

Note: If your fan installation includes an extension tube, the safety cable is already attached to the extension tube. If you are mounting the fan without an extension tube, the safety cable is packed separately.

I-Beam mount

Secure the safety cable by wrapping it around the I-beam and connecting the looped ends with the shackle as shown. The cable must be drawn tightly around the I-beam, leaving as little slack as possible. If possible, the shackle should be on the topside of the I-beam. Securely tighten the shackle.

Proceed to step 3.

Angle iron mount (with extension tube)

Secure the safety cable by wrapping it around the angle irons and connecting the looped ends with the shackle as shown. The cable must be drawn tightly around the angle irons, leaving as little slack as possible. The shackle should be on the topside of the angle irons if possible. Securely tighten the shackle.

Proceed to step 3.

Angle iron mount (no extension tube)

Route the cable through the motor frame and around the angle irons as shown. Connect the looped ends of the cable with the shackle. The cable must be drawn tightly around the angle irons, leaving as little slack as possible. The shackle should be on the topside of the angle iron if possible. Securely tighten the shackle.

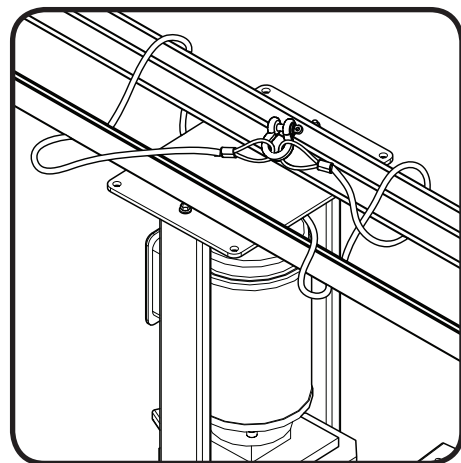
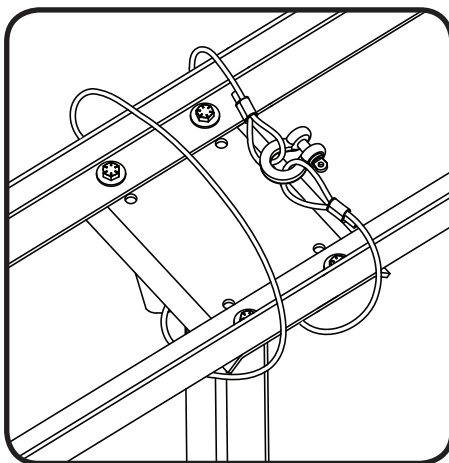
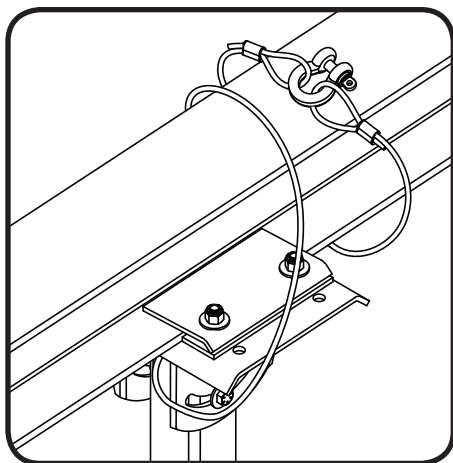

Shackle

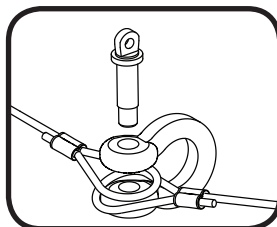

3. Attach lower yoke (to extension tube)

Attach the lower yoke to the bottom of the extension tube with the Lower Yoke Hardware as shown.

Tighten the hardware so that it is snug, but not fully tightened.

Lower Yoke Hardware (BAF-Supplied):

- a. (2) 1/2-13 x 4-1/2" GR 8 Bolt
- b. (4) 1/2" Flat Washer
- c. (2) 1/2-13 Nylock Nut

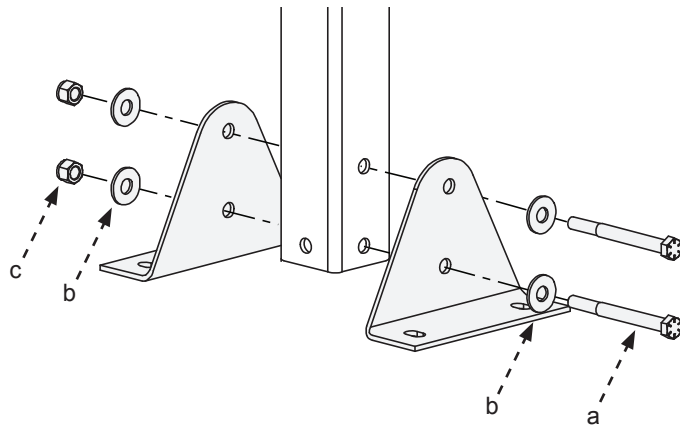

4. Attach main fan unit (to lower yoke)

⚠ CAUTION: The main fan unit is heavy. Use caution when raising it.

Attach the main fan unit to the lower yoke with the Main Fan Unit Hardware as shown. *Do not rest the main fan unit on the ground! Make sure the lower cable is positioned between the lower yoke brackets as shown on the right.*

Tighten the bolts to **40 ft·lb (54.2 N·m)** using a torque wrench and 3/4" socket. *Do not discard the main fan unit packaging. It should be used if the fan is ever moved or relocated.*

Main Fan Unit Hardware (BAF-Supplied):

- a. (4) 1/2-13 x 1-3/4" GR 8 Bolt
- b. (8) 1/2" Flat Washer
- c. (4) 1/2-13 Nylock Nut

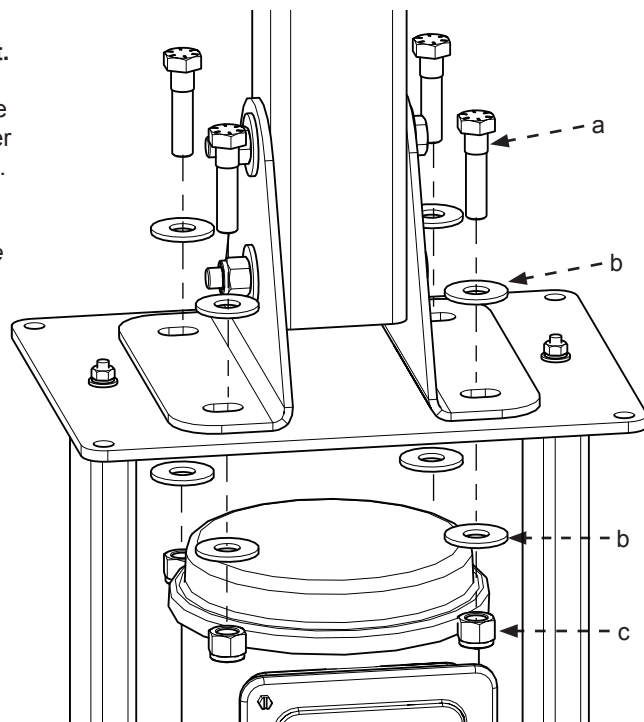

5. Confirm orientation

After securing the main fan unit to the lower yoke, allow the fan to hang so that the extension tube is plumb to the ground. When it is properly positioned, fully tighten the mounting hardware (Lower Yoke Hardware and Extension Tube Hardware) to **40 ft·lb (54.2 N·m)**.

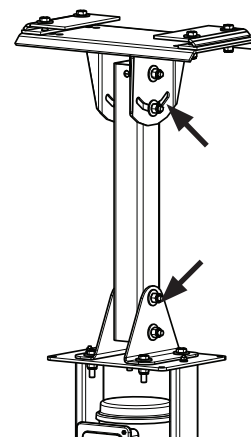

20

Installing Guy Wires

Guy wires may not be included in your fan order. They are intended to constrain the fan's lateral movement and are only included with all fans that have extension tubes 4 ft (1.2 m) or greater in length. Depending on the conditions at the installation site, guy wires may be needed for fans with shorter tubes to prevent any lateral movement. If guy wires are needed and were not included with your fan order, contact Big Ass Fans Customer Service.

⚠ WARNING: Disconnect power to the fan before installing the guy wires.

1. Attach locking carabiners to main fan unit

Attach the (4) locking carabiners to the guy wire brackets on the main fan unit as shown. Securely tighten the carabiners.

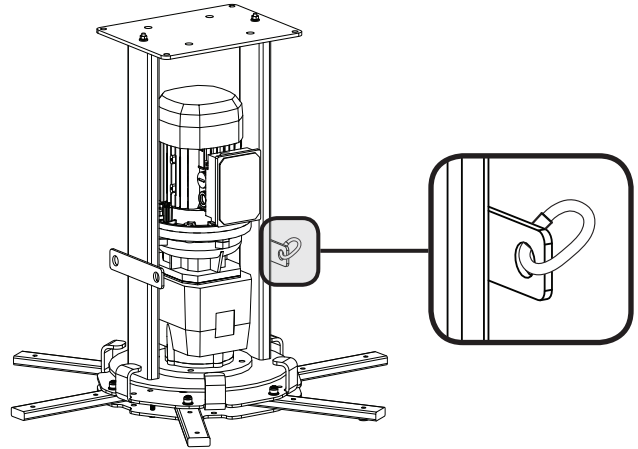

2. Attach beam clamp

Attach the beam clamp to the mounting structure. *The guy wire should be approximately 45° from the horizontal plane. Place the beam clamp accordingly.* Fully tighten the set screw to secure the clamp.

For best results, the guy wires should be installed at 45° in the X-Y, Y-Z, and X-Z planes as shown below. If the angle deviates by more than 15°, contact Customer Service for assistance.

Fasten the small eyebolt and nut onto the beam clamp. The nut will be on the outside of the beam clamp.

Loop the crimped end of the guy wire into the locking carabiner and secure to the eyebolt as shown. Securely tighten the carabiner.

Beam Clamp

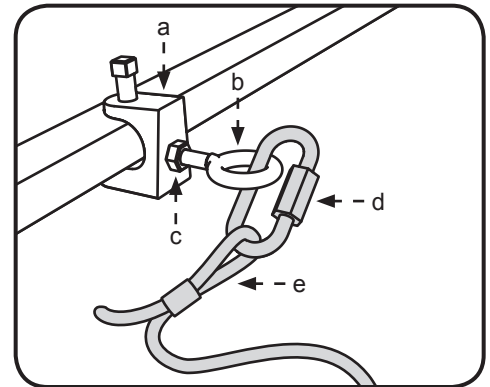

Guy Wire Hardware (BAF-Supplied):

- a. 1/4" Beam Clamp
- b. 1/4-20 x 1" Eyebolt
- c. 1/4-20 Hex Nut
- d. Locking Carabiner
- e. Guy Wire

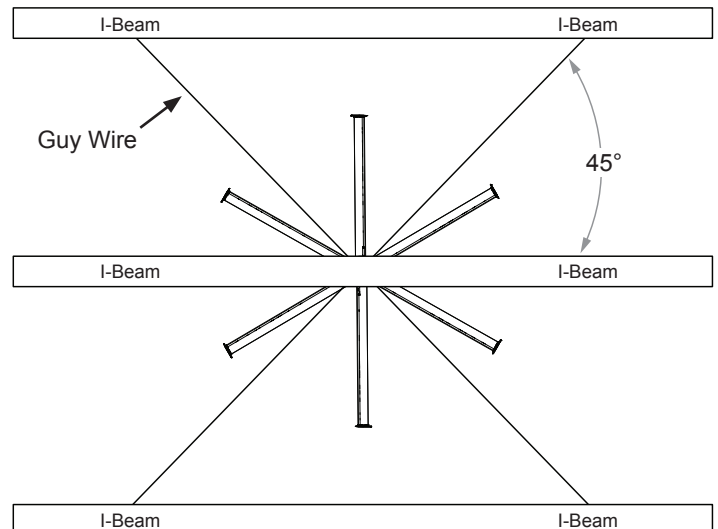
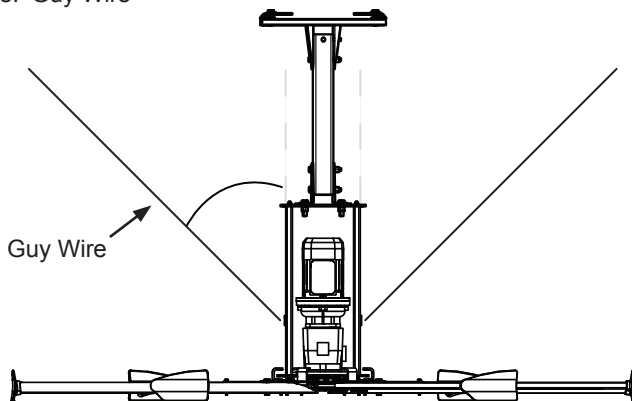

Note: I-beams shown above. Your mounting structure may differ.

3. Route guy wire through Gripple®

Route the guy wire through the Gripple, the carabiner on the fan, and then back through the Gripple as shown. Do not tighten the Gripple until the remaining guy wires have been installed.

Note: To back the guy wire out of the Gripple, insert 1/16 (1.5 mm) Allen wrench into the small hole on the Gripple.

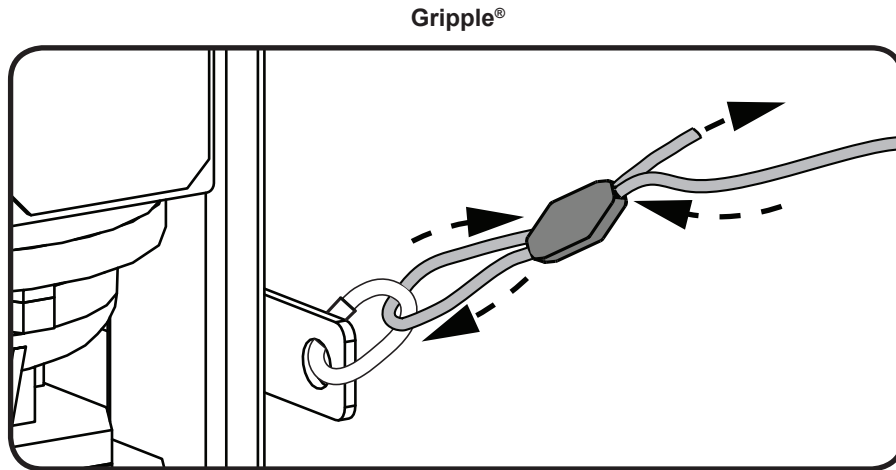

4. Install remaining guy wires

⚠ CAUTION: Over-tightening the guy wires could throw the fan off balance.

Repeat steps 2–3 to install the three remaining guy wires.

Evenly cinch all four guy wires into place using the Gripples. The guy wires should be taut, evenly spaced around the fan, and away from the path of the airfoils. Maintain a distance of 6"–8" between the Gripple and the carabiner.

Once all of the guy wires are taut, secure their loose ends with the wire rope clips and torque to **4.5 ft·lb (6.1 N·m)**. *Ensure all electrical cords/cables are unobstructed by the guy wire system.*

Wire Rope Clip

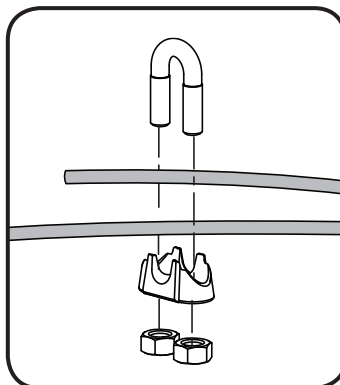

Installing Airfoils

Big Ass Fans recommends completing electrical installation (page 23) before installing the airfoils.

⚠ WARNING: Disconnect power to the fan before installing the airfoils.

1. Attach winglets to airfoils

Attach the winglet to the airfoil using the Winglet Hardware as shown. Both a Phillips head and flat head screwdriver are required to properly secure the fasteners. *Attach winglets to all six airfoils before attaching the airfoils to the fan.*

Winglet Hardware (BAF-Supplied):

- a. (6) 10-24 x 3/4" Barrel
- b. (6) 10-24 x 1/2" Bolt

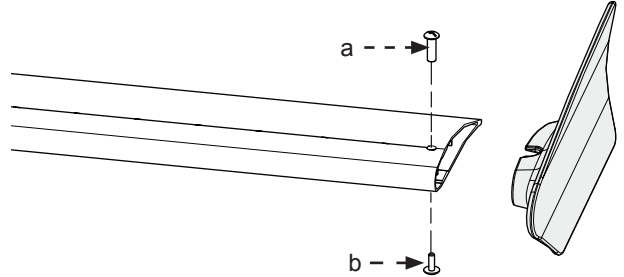

2. Attach airfoils to hub

Slide airfoils onto the tabs of the fan hub. *The airfoils must be attached to the fan hub with the curved sides facing downward.*

Attach the six airfoil retainers with the Airfoil Hardware. Moving clockwise around the fan hub, position the airfoil retainers end over end as shown. Hole A of the retainer should be positioned over top of Hole B. *Do not tighten the bolts until all the airfoil retainers have been attached!*

Tighten the bolts along the outer perimeter to **29 ft·lb (39.3 N·m)** using a torque wrench and 1/2" socket. After the outer perimeter bolts are torqued, tighten the bolts along the inner perimeter to **29 ft·lb (39.3 N·m)** using a torque wrench and 1/2" socket.

Airfoil Hardware (BAF-Supplied):

- a. (12) 5/16-18 x 2" GR 8 Bolt
- b. (24) 5/16" Flat Washer
- c. (12) 5/16-18 Nylock Nut

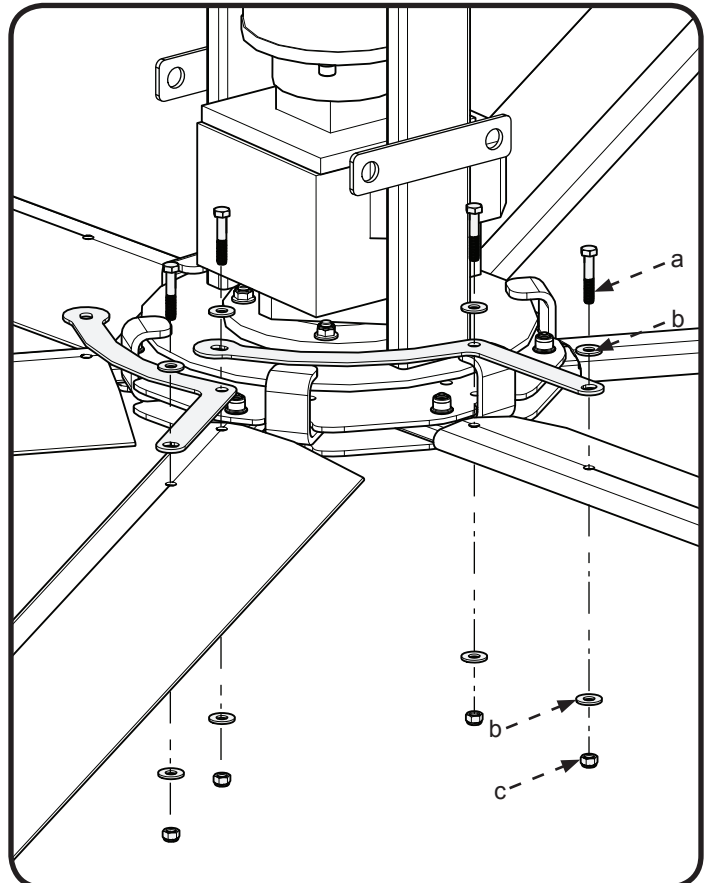
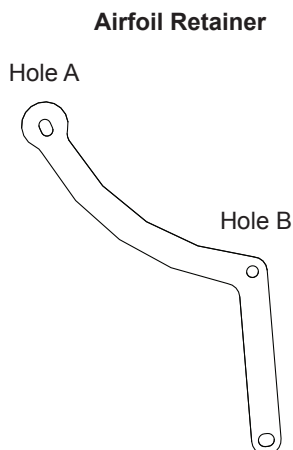

Electrical Installation



WARNING: To reduce the risk of electric shock, wiring should be performed by a qualified electrician! Incorrect assembly can cause electric shock or damage the motor and the controller! Hazard of electrical shock!

WARNING: The installation of a Big Ass Fan must be in accordance with the requirements specified in this installation manual and with any additional requirements set forth by the National Electric Code (NEC), ANSI/NFPA 70-2011, and all local codes. Code compliance is ultimately YOUR responsibility!

WARNING: The fan controllers contain high voltage capacitors that take time to discharge after removal of mains supply. Before working on the fan controller, ensure isolation of mains supply from line inputs at the fan controller's disconnect if installed. Wait three (3) minutes for capacitors to discharge to safe voltage levels. Failure to do so may result in personal injury or death. Note: Darkened display LEDs are not an indication of safe voltage levels.

CAUTION: It is the sole responsibility of the installer to verify the operating voltage of the fan system prior to installation! It is also mandatory that the installer verify that airfoils, motor hub assemblies, and fan controllers are matched properly at the time of installation, especially if multiple fan systems will be installed.

CAUTION: An incorrectly installed controller can result in component damage or reduction in the fan's life. Wiring or application errors such as under-sizing the controller, incorrect or inadequate AC supply, or excessive ambient temperatures may result in a malfunction of the fan system. Verify correct voltage, phase, and horsepower before beginning installation!

WARNING: Exercise caution and common sense when powering the fan. Do not connect the fan to a damaged or hazardous power source. Do not attempt to resolve electrical malfunctions or failures on your own. Contact Big Ass Fans if you have any questions regarding the electrical installation of this fan.

CAUTION: For use with Big Ass Fans-supplied variable frequency drive only. Not for use with other speed control devices!

CAUTION: Shielded cable, if applicable, must be landed on the motor's ground terminal!

CAUTION: To avoid a short circuit, be very careful not to get metal chips in the controller!

CAUTION: The Big Ass Fans product warranty will not cover equipment damage or failure that is caused by improper installation.

CAUTION: The following information is merely a guide for proper installation. The Big Ass Fans Company cannot assume responsibility for the compliance or the non-compliance to any code, national, local, or otherwise for the proper installation of these fan controllers, fans, or associated equipment. A hazard of personal injury and/or equipment damage exists if codes are ignored during installation.

If you are installing an onboard variable frequency drive (VFD), ensure you route the power wiring to the fan location.

Electrical installation overview

The electrical installation section is intended for a professional electrician. If you are unfamiliar or uncomfortable with installing electrical components, do not attempt to install the fan without an electrician. Serious personal injury or damage to the fan and other equipment could result. This guide is merely a recommendation of proper installation. Adhering to national and local electric codes is your responsibility. It is the sole responsibility of the installer to verify the operating voltage of the fan system prior to installation! It is also mandatory that the installer verify that airfoils, motor assemblies, and fan controllers are matched properly at the time of installation, especially if multiple fan systems will be installed.

The following sections outline how to prepare for the electrical installation, and include the required cables and how to properly route the cabling through conduit, how to properly ground the fan system, how to properly wire the fan controller, how to properly wire the fan motor, and proper startup procedures.

Controller storage

Store the controller within an ambient temperature range of -40°F to 185°F (-40°C to 85°C) and a relative humidity range of 0 to 95%, non-condensing. Do not expose the controller to a corrosive atmosphere. If the controller has been in storage or disconnected from power for more than one year, apply AC supply power to the controller for a period of two hours prior to operation in order to recondition the internal DC bus capacitors.

Power requirements for fan controllers

The power requirements for fan controllers are listed in the table on page 2. If multiple controls are connected to one feeder circuit, the circuit required is the sum of the feeder circuit requirements listed on the chart. This type of installation will also require that each fan control be installed downstream from a dedicated over-current protection device.

Mounting the wall controller

If you are mounting the controller to the fan motor frame instead of the wall (onboard VFD option), skip this section and refer to the mounting instructions that came with the wall controller and hardware for the onboard VFD.

Mount the controller to a wall using a #8-#10 screw. Adhere to the following guidelines when selecting the controller location:

- Install the controller on a flat surface that is readily accessible, free from vibration, and where there is adequate distance from foreign objects or moving equipment.
- Do not mount any controller adjacent to or above a heat source or heat-producing equipment.
- The ambient temperature must be between 14° F (-10° C) and 122° F (50° C).
- Do not expose the controller to a corrosive atmosphere or direct sunlight.
- When mounting the controller, keep in mind that the fan should be visible from the controller.
- A minimum distance of 6" (15.2 cm) should be maintained between fan controllers.

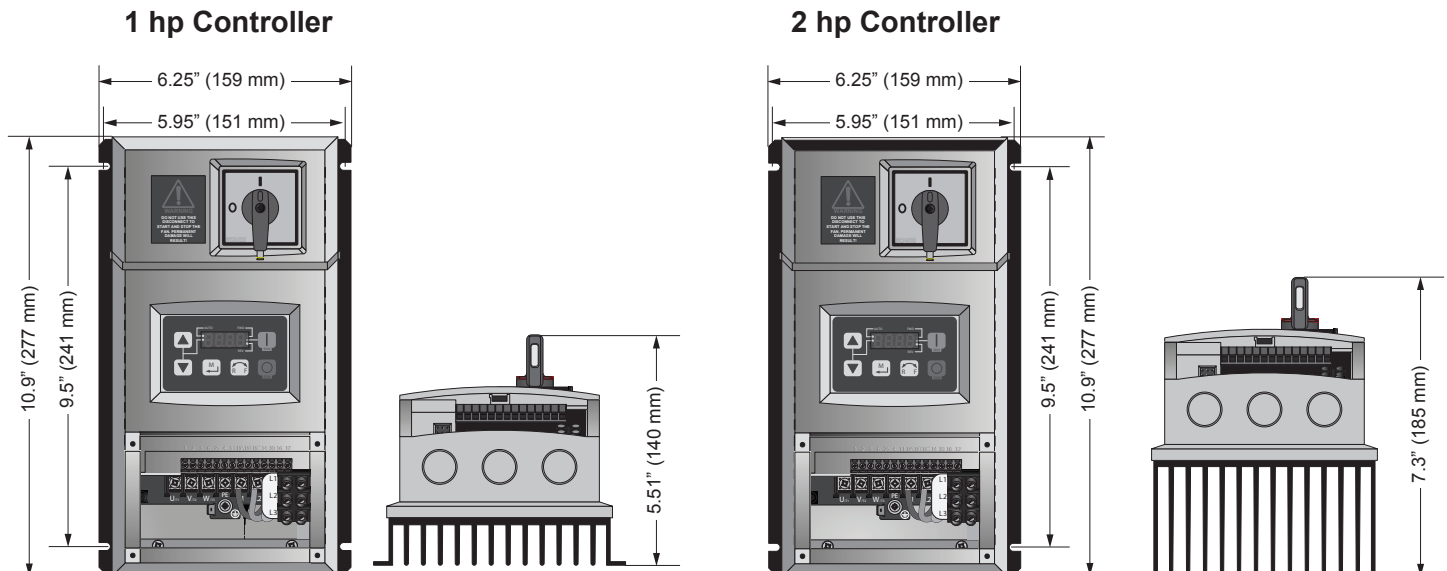

Input power conditioning

Line reactors should be installed if AC supply is subject to any of the following:

- Low line impedance
- Frequent power interruptions
- Phase-to-ground voltage in excess of 125% nominal phase-to-phase voltage
- Distribution system exceeds established kVA limit for your specific model (contact Big Ass Fans for more information).
- Power factor correction capacitors
- Intermittent noise spikes (lightning)

Conduit and piping guidelines

⚠ CAUTION: The presence of foreign signals on a drive's output wiring greatly reduces the controller's ability to control current and speed regulation of the fan. Any wiring practice that would allow this kind of "cross-talk" must be avoided. Failure to do so may result in nuisance tripping and/or premature equipment failure. Sources of foreign signals that could induce such signals include another VFD's output circuit, long "across-the-line" motor circuits, and lighting circuits.

⚠ CAUTION: Recommendations for fan controller output/motor lead routing deem some conventional wiring practices "unacceptable." National and/or local code does not differentiate between solid-state and electromechanical systems; however, due to the nature of the Big Ass Fan system, there are additional requirements that must be met to ensure proper operation.

The nature of Variable Frequency Drive systems (VFD) must be considered prior to and during the installation of Big Ass Fans. Due to high frequency electrical noise on the output side of the fan controller, measures must be taken to ensure that wires and cabling are routed in a manner consistent with recommendations made in this section. Big Ass Fans controllers rely on "motor feedback" through the cabling to sense motor speed, slip, etc.

Controller AC supply

Most conventional methods of power distribution and branch circuit installation apply to all models of fan controllers. Installation must comply with specifications regarding wire types, conductor sizes, branch circuit protection, and disconnecting devices. Failure to do so may result in personal injury and/or equipment damage. Refer to page 2 for specific ampacities.

- AC supply feeds for one fan controller can share the same conduit with AC supply feeds for one or more additional controllers.
- AC supply feeds for a fan controller and output/motor leads for the same fan controller cannot share a conduit.
- AC supply feeds for one fan controller cannot share conduit with output/motor leads from one or more additional controllers/VFDs.
- Any unused conductors that share a conduit with an AC supply feed should be grounded on both ends to prevent risk of electric shock due to induced voltages.
- Output/motor leads for a fan controller and AC supply feeds for the same fan controller cannot share a conduit.
- Output/motor leads for one fan controller cannot share conduit with AC supply feeds or output/motor leads from one or more additional fan controllers.
- Any unused conductors that share a conduit with fan controller output/motor leads should be grounded on both ends to prevent risk of electric shock due to induced voltages.

26

Electrical Installation (cont.)

Power wiring guidelines

In order to satisfy some code requirements, it may be necessary to install a manual disconnect at the fan motor location when the fan assembly is not within "line-of-sight" from the fan controller. A non-fused, 600 V, 3-phase, blade style disconnect should be used to satisfy this "line-of-sight" requirement.

- ⚠ **WARNING:** Installation must comply with specifications from National Electrical Codes and standards (NEC, VDE, BSI, etc.) regarding wire types, conductor sizes, branch circuit protection, and disconnecting devices.
- ⚠ **WARNING:** To avoid a possible shock hazard and/or nuisance tripping caused by induced voltages, unused wires in the conduit must be grounded at both ends. For the same reason, fan controller output wires should not share a conduit with another fan controllers output leads, or other power circuits (lighting, motors, etc.).
- ⚠ **CAUTION:** MC or "Metal clad" cable cannot be used for controller output/motor leads. Both stranded and solid core varieties must be avoided. Do not use solid core cable of any size or insulation class for motor wiring. Use of such types of cabling may result in nuisance tripping or premature equipment failure.

A variety of cable types are acceptable for variable frequency drive installations. *For many installations, unshielded cable is adequate if it can be separated from sensitive circuits.* In all cases, parallel runs of control and motor cabling should be avoided when unshielded cable is used. Do not use cable with an insulation thickness of less than 15 mils.

- UL installations in 50°C ambient must use 600V, 75°C or 90°C wire.
- UL installations in 40°C ambient should use 600V, 75°C or 90°C wire.

Acceptable unshielded types

THHN, THNW, or similar wire is acceptable for drive installations in dry environments if adequate free air space and/or conduit fill rate limits are provided. *Do not use THHN or similarly coated wire in wet areas.* Any wire chosen must have a minimum insulation thickness of 15 mils and should not have large variations in insulation concentricity.

Acceptable shielded types

The drain conductor included with shielded cables must be connected to both the motor frame and the PE/Ground terminal of the Variable Frequency Drive.

Location	Rating / Type	Description
Standard (Option 1)	600V, 75°C or 90°C (167°F or 194°F) RHH/RHW-2	<ul style="list-style-type: none"> • Four tinned conductors with XLPE insulation • Foil shield and tinned copper drain wire with 85% braid coverage • PVC Jacket
	Belden 29501-29507 or equivalent	
Standard (Option 2)	Tray rated 600V, 75°C or 90°C (167°F or 194°F) RHH/RHW-2	<ul style="list-style-type: none"> • Three tinned copper conductors with XLPE insulation • 5 mil single helical copper tape (25% overlap minimum) with three bare copper grounds in contact with shield • PVC Jacket
	Shawflex 2ACD/3ACD or equivalent	
Class I & II Division I & II	Tray rated 600V, 75°C or 90°C (167°F or 194°F) RHH/RHW-2	<ul style="list-style-type: none"> • Three bare copper conductors with XLPE insulation with impervious corrugated continuously welded aluminum armor • Black sunlight resistant PVC jacket overall • Three copper grounds on #10 AWG and smaller

Maximum cable lengths

To prevent nuisance trips, the distance between the controller and the fan should not exceed 400 ft (122 m).

Output disconnects

A device, such as a contactor, that routinely disconnects and reapplies output power to the motor for the purpose of starting and stopping the motor cannot be used.

Recommended wire size

A minimum of 14 AWG is acceptable for motor leads. *14 AWG applies to motor leads only.* Power feeders to controllers must be governed by the fuse size included with the fan controller and/or required circuit breaker.

Grounding

The nature of Variable Frequency Drive systems must be considered prior to and during the installation of Big Ass Fans. Due to high frequency content on the output side of the fan controller, measures must be taken to ensure that all grounding connections conform to the recommendations made in this section.

The fan controller's safety ground  (PE) must be connected to system ground. Ground impedance must conform to the requirements of national and local industrial safety regulations and/or electrical codes. The integrity of all ground connections should be periodically checked. All ground leads for downstream conduit boxes must be kept separate from the motor ground and terminated on the fan controller's PE terminal.

Motor ground

The motor ground must be connected to a ground terminal on the VFD to aid in keeping high frequency electrical noise off of the building's ground grid.

Shielded motor cable terminations

Either of the safety ground terminals on the drive provides a grounding point for the motor cable shield. The motor cable shield connected to one of the drive terminals must also be connected to the motor frame. If no drain lead is present, the cable must be stripped back so that the braid can be twisted and soldered to a pigtail for proper termination.

Installing the Electronic Programming Module (EPM)

If hanging multiple fans, ensure to install the exact EPM included in each fan's packaging. EPMs are not interchangeable!

⚠ WARNING: Install the EPM prior to applying power to the fan controller!

The EPM contains all programming information specific to fan operation. It *must* be installed prior to applying power to the fan controller. This module is provided as part of the fan's accessory kit.

To install the EPM, disconnect the fan from power (refer to the position of the disconnect switch below). Insert the EPM in the location shown below. *Note: The EPM module can only be inserted one way. Do not force it!*



Wiring: ESFR (Early Suppression Fast Response)

⚠ WARNING: Wait three minutes after disconnecting before servicing!

⚠ WARNING: Improper installation can cause electric shock or damage to the motor and controller. A qualified electrician should perform the installation.

ATTENTION: If installing the fan in the United States, the fan must be installed per the following National Fire Protection Association (NFPA) guidelines:

- The fan must be centered approximately between four adjacent sprinklers.
- The vertical distance from the fan to the sprinkler deflector must be at least 3 ft (91.4 cm).
- The fan must be interlocked to shut down immediately upon receiving a waterflow signal from the alarm system.

The fire relay included with the fan is needed only if the fan will be installed in a building that has a fire sprinkler system. The fire relay integrates the fan with the sprinkler system and shuts down the fan upon receiving an alarm signal from the system. If the building in which the fan will be installed has a sprinkler system, you must install the relay according to the instructions below.

A contact closure across the digital input terminals 4 and 13A will result in fan shutdown. The included relay uses a Normally Open (N.O.) contact as shown below. The relay coil must be energized by the FACP for fan shutdown. Optionally, the normally closed (N.C.) relay contact can be used. The relay coil must remain energized by the FACP for fan operation. This would be considered a fail safe or fail open wiring arrangement. Two additional relay coil leads are provided to facilitate supervision pass-through where required.

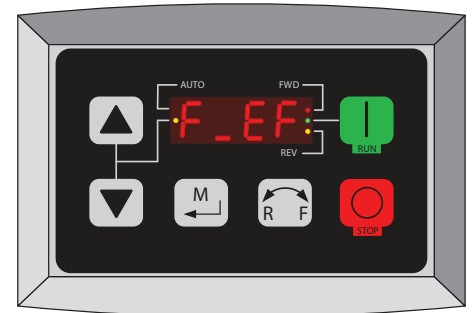
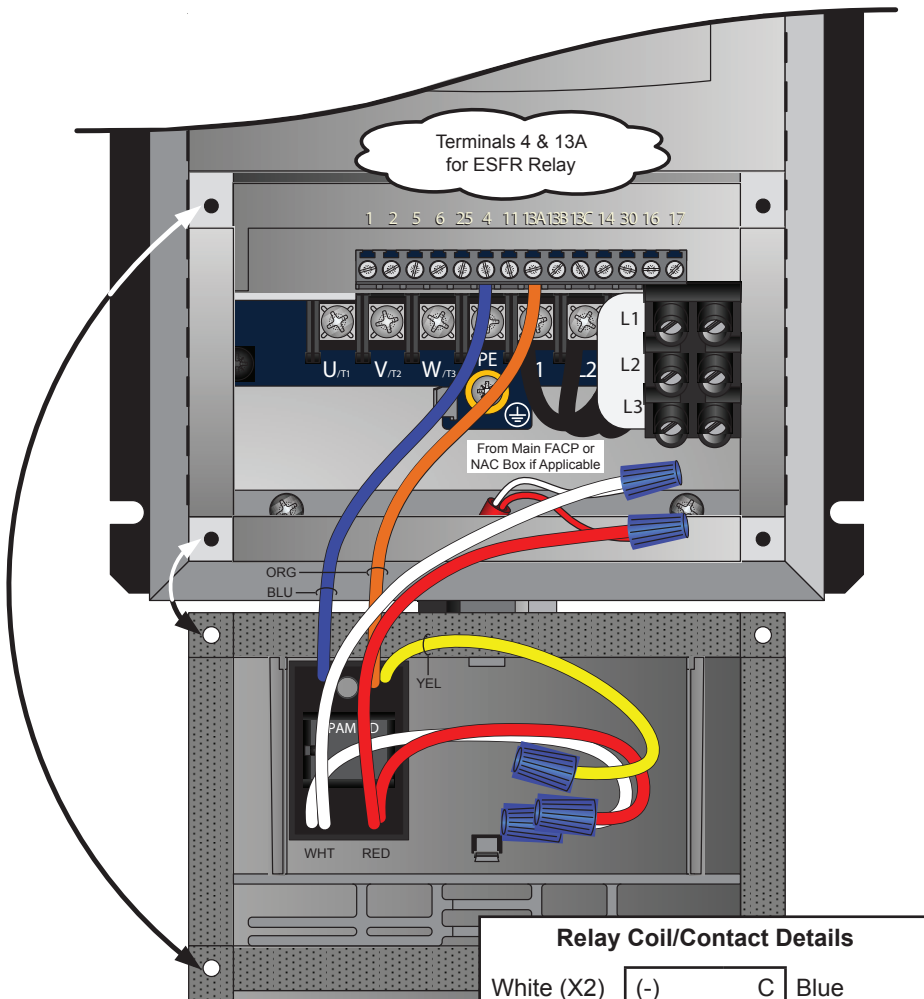

An alarm condition will stop the fan and issue an "F_EF" external fault on the controller's display.

Relay Coil/Contact Details			
White (X2)	(-)	C	Blue
		NC	Yellow
Red (X2)	(+)	NO	Orange
Coil: 20-32 VDC @ 20 mA			

Relay is mounted to the backside of the access cover.

30

Electrical Installation (cont.)

Wiring: 100–125V/200–250V single-phase fan controllers

- ⚠ **WARNING:** Wait three minutes after disconnecting before servicing!
- ⚠ **WARNING:** Improper installation can cause electric shock or damage to the motor and controller. A qualified electrician should perform the installation.

The diagram below shows wiring options for a 100–125 V/200–250 V, 1 Φ fan controller. See page 2 for detailed power requirements.

Wiring for 200–250 V, 1 Φ , 50/60 Hz fan controllers

The neutral terminal is not used when wiring the fan controller for 200–250 V, 1 Φ . A disconnect and EMI filter are included with this fan controller.

Note: This fan controller does not contain fusing! Power must be supplied to this controller via a dedicated circuit breaker or properly fused disconnect!

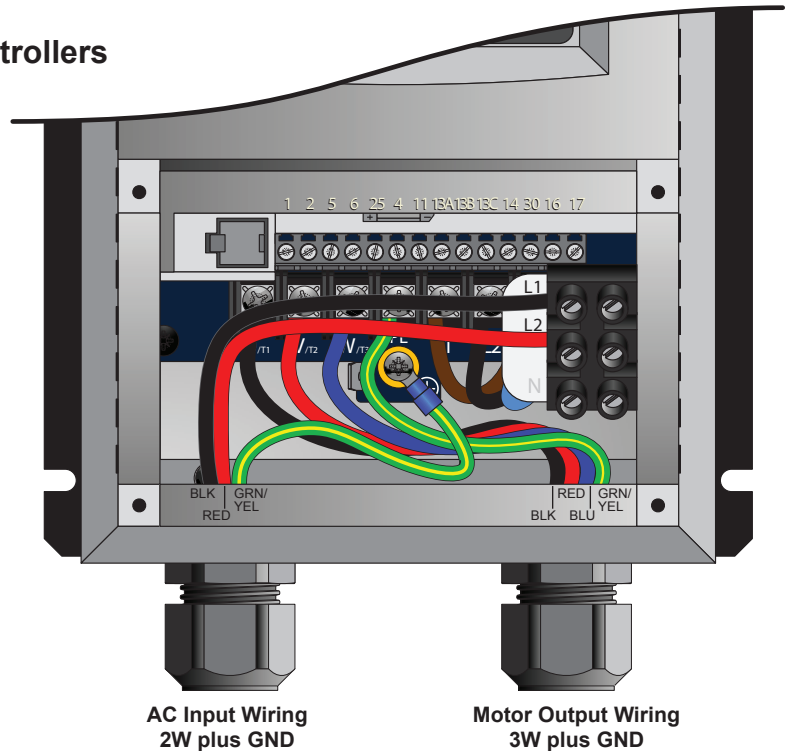
Optional wiring for 100–125 V, 1 Φ , 50/60 Hz fan controllers

The L2 terminal is not used when wiring the fan controller for 100–125 V, 1 Φ . A disconnect is included with this fan controller.

Note: This fan controller does not contain fusing! Power must be supplied to this controller via a dedicated circuit breaker or properly fused disconnect!

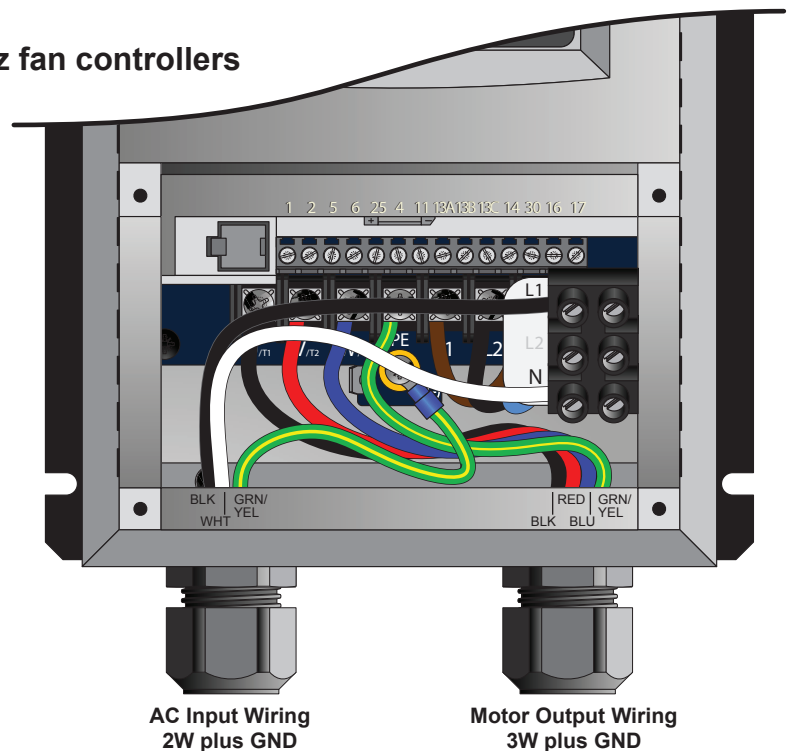

Wiring: 200–250 V, three-phase fan controllers

- ⚠ WARNING:** Wait three minutes after disconnecting before servicing!
- ⚠ WARNING:** Improper installation can cause electric shock or damage to the motor and controller. A qualified electrician should perform the installation.

The diagram below shows wiring options for a 200–250 V, 3 Φ fan controller. See page 2 for detailed power requirements.

Wiring for 200–250 V, 3 Φ , 50/60 Hz fan controllers

A disconnect is included with the fan controller for 200–250V 3 Φ . An EMI filter is not included with this fan controller.

*Note: This fan controller does not contain fusing!
Power must be supplied to this controller via a dedicated circuit breaker or properly fused disconnect!*

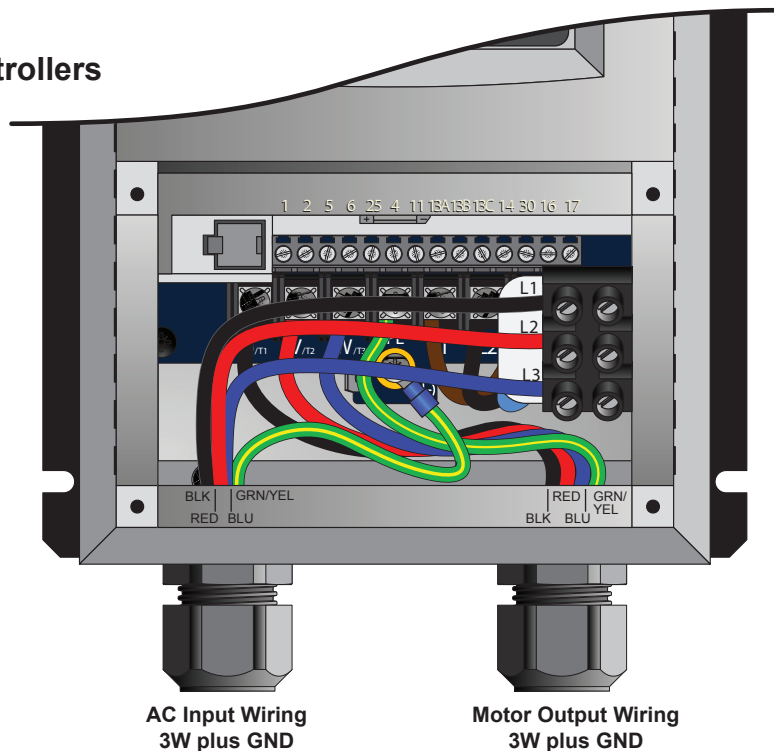

Optional 1 Φ wiring for 200–250 V, 3 Φ , 50/60 Hz controllers

The L3 terminal is not used when wiring the fan controller for 200–250 V, 1 Φ . A disconnect is included with the fan controller. An EMI filter is not included with this fan controller.

*Note: This fan controller does not contain fusing!
Power must be supplied to this controller via a dedicated circuit breaker or properly fused disconnect!*

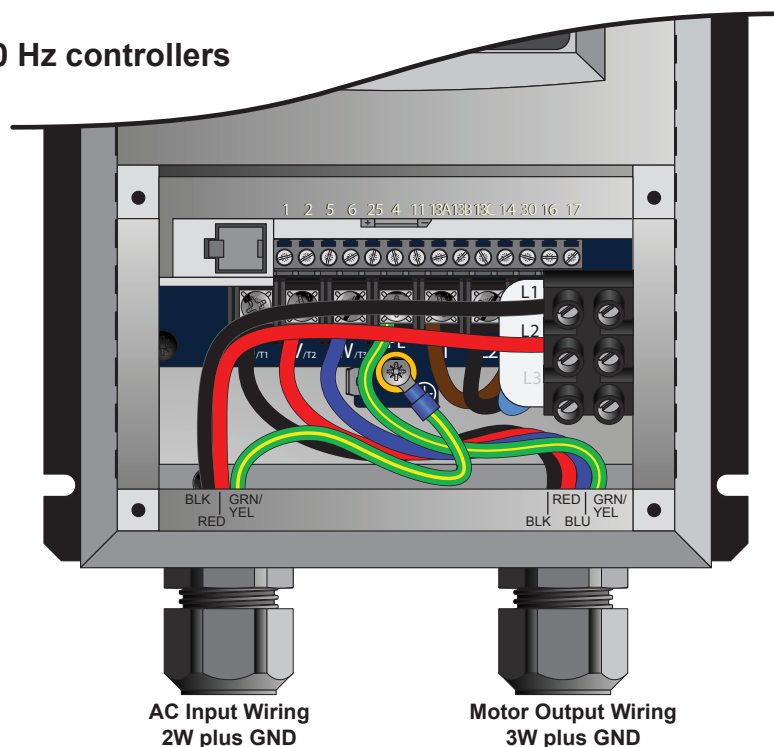

Wiring: 400–480 V & 575–600 V, three-phase fan controllers

- ⚠ WARNING: Wait three minutes after disconnecting before servicing!**
- ⚠ WARNING: Improper installation can cause electric shock or damage to the motor and controller. A qualified electrician should perform the installation.**

The diagram below shows wiring options for 400–480 V, 3 Φ and 575–600 V, 3 Φ fan controllers. See page 2 for detailed power requirements.

Wiring for 400–480 V, 3 Φ , 50/60 Hz fan controllers

An EMI filter and disconnect are included with the fan controller for 400–480 V, 3 Φ .

Note: This fan controller does not contain fusing! Power must be supplied to this controller via a dedicated circuit breaker or properly fused disconnect!

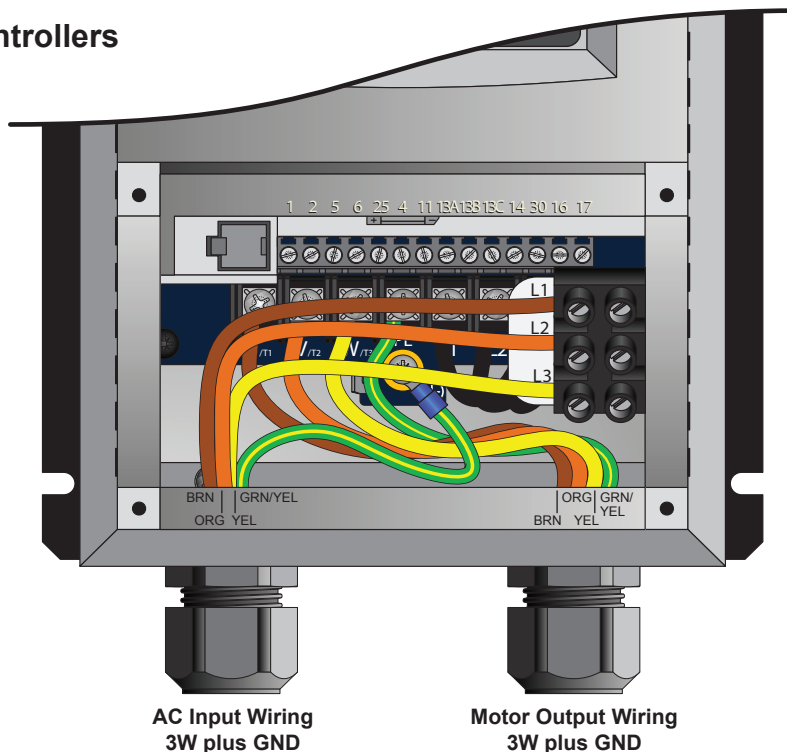

Wiring for 575–600 V, 3 Φ , 50/60 Hz controllers

A disconnect is included with the fan controller for 575–600 V, 3 Φ . An EMI filter is not included with this fan controller.

Note: This fan controller does not contain fusing! Power must be supplied to this controller via a dedicated circuit breaker or properly fused disconnect!

Note: When installing Basic 6® fans in Canada, customers with 600 VAC distribution must consider one of two options to avoid damage to the motor:

1. Use the Onboard VFD kit, or
2. Utilize 200–240 VAC rated fans and controllers on their low voltage power distribution (if they have room for the additional circuits).

The motors used for Basic 6 fans are rated per NEMA MG1 standards, which states that the motor insulation must withstand 1,600 V PEAK-PEAK. 575–600 VAC applications will exceed the safe voltage level of the motor insulation system, resulting in a motor insulation breakdown and subsequent motor failure.

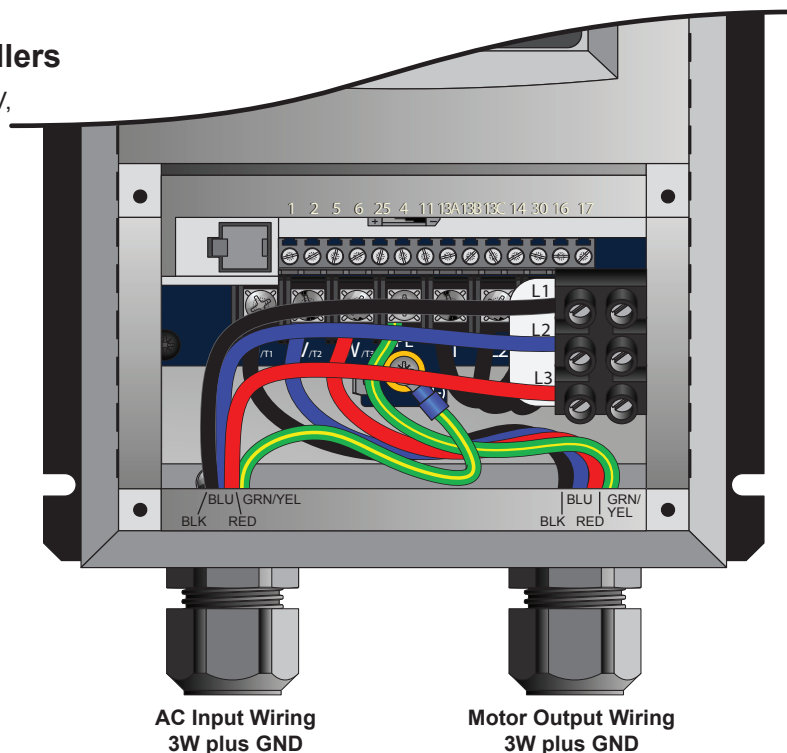

Daisy chaining

⚠ WARNING: Wait three minutes after disconnecting before servicing!

The following illustrations and parameter changes enable daisy chaining of the Basic 6® fan speed controller. The first fan provides a start/stop contact and 0–10 VDC analog speed reference for the downstream fan controller. The downstream fan controller provides a new start/stop contact and 0–10 VDC analog speed reference for the following downstream fan controller. This preferred method of linking the fan controllers together ensures minimal signal loss of command signals in larger multi-fan systems.

Assertion Level Switch (ALSW)

The fan controller ships with the onboard digital I/O configured for Sourcing (PNP) operation. Terminal 4 provides +15 VDC to be used as a supply voltage for user-supplied switches and accessories. For this 3-wire daisy chaining application, the downstream fan controllers must be switched to Sinking (NPN) operation. Terminal 4 will then provide a DC common connection and allow the analog signal and start stop signal to share that common. **The Assertion Level Switch above terminal 4 must be switched from (+) to (-) on all downstream fan controllers for proper daisy chaining operation prior to powerup, parameter changes and operation.**

Parameter changes (for first controller)

Parameter	Description
P140	Relay Output Function Change from "0" for None to "1" for Run.
P150	TB-30 Output Change from "0" for None to "1" for 0–10 VDC output (scaled to drive output frequency).
P152	TB-30 Scaling Frequency Change to equal the frequency setting of P103 Maximum Frequency.
P161	Speed at Max Signal Change to equal the frequency setting of P103 Maximum Frequency.

Parameter changes (for downstream controllers)

Parameter	Description
P120	Assertion Level Change from "2" for High to "1" for Low.
P100	Start Control Source Change from "0" for keypad operation to "1" for Terminal Strip.
P101	Standard Reference Source Change from "0" for keypad operation to "1" for 0–10 VDC analog input operation.

Note: Depending on the AWG and distance of the low voltage wiring, the downstream fans may run slightly slower than the leading fan. If this occurs, P161 Speed at Max Signal can be used to introduce a minor command reference overshoot to compensate for the analog voltage drop. At each downstream fan (beginning with the first downstream fan), adjust the value of P161 up 0.1 to 0.2 Hz increments until the fan's output frequency matches that of the lead fan.

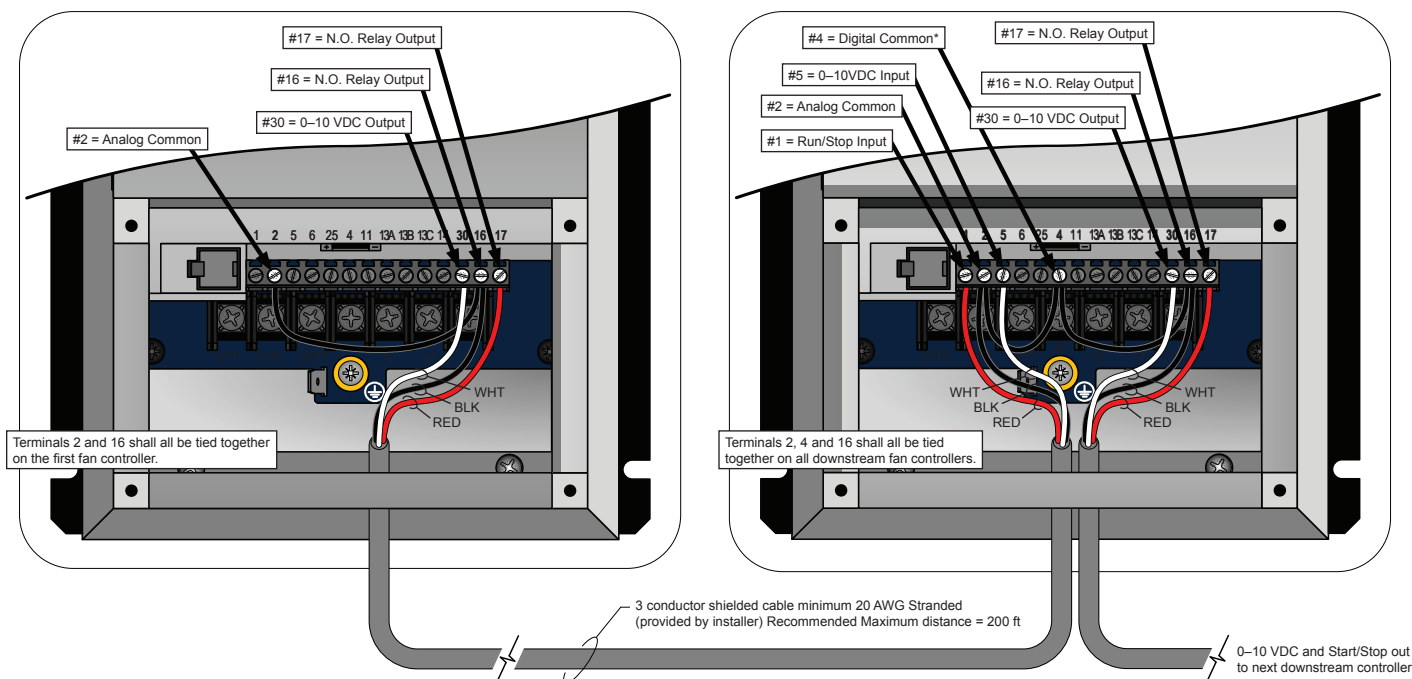

Wiring the motor: 9-lead, dual voltage, wye motor configurations

The motor wiring configurations shown below are applicable to 9-lead, dual voltage wye wound motors rated for 230/460 VAC and 330/600 VAC. Consult the motor nameplate and/or wiring placard for verification of required wiring connections. Motors with terminal blocks require ring terminals and a 7 mm nut driver for termination. The diagrams below include L2 and L3 swap to yield proper motor rotation. *Note: Swapping leads to reverse rotation is done only on the output side of the drive.*

Low Voltage
200–240 VAC, 50–60 Hz
330–350 VAC, 50–60 Hz

High Voltage
400–480 VAC, 50–60 Hz
575–600 VAC, 50–60 Hz

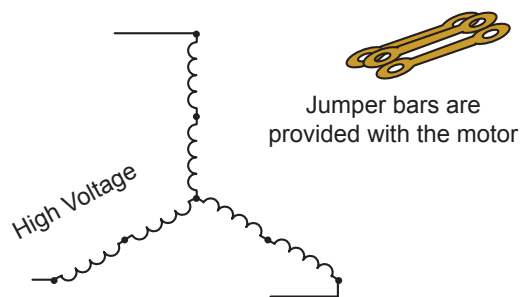
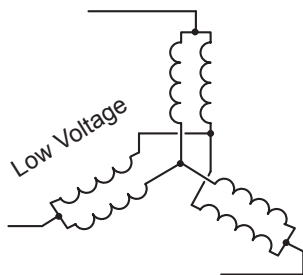
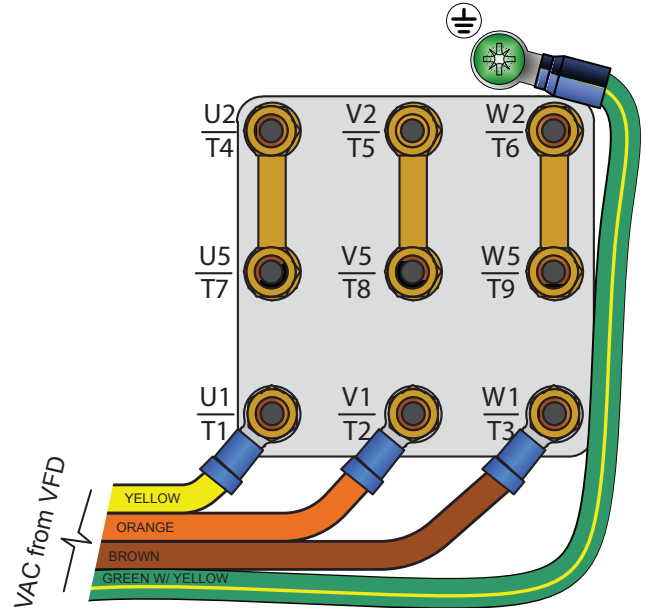
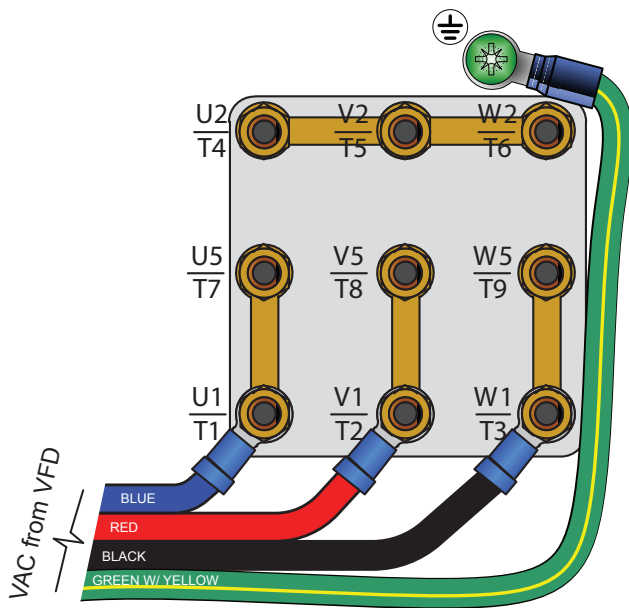

Operating the fan controller

⚠ WARNING: The following startup procedures apply to standard model controllers. Procedures may vary depending on installation options and system automation. The installer should verify proper wiring, terminations, and proper voltage supply before proceeding. High voltage gloves and arc flash protection are recommended.

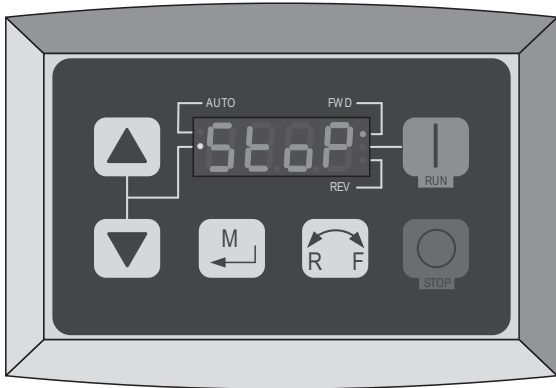

Drive Idle/Stopped Screen

Starting and stopping the fan

The RUN and STOP buttons control the fan start and stop functions. **To start the fan**, press the green RUN button. **To stop the fan**, press the red STOP button.

Adjusting fan speed

The Arrow buttons control speed adjustment. **To adjust fan speed**, press the Up or Down Arrow button. Single presses will increase or decrease the speed in 1-2% increments. Pressing and holding the Up or Down Arrow button will slowly and continuously adjust fan speed until the button is released.

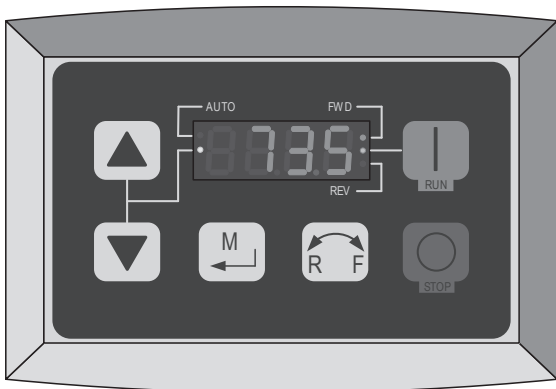

Fan Speed Percentage Display
(73.5% Running FWD)

Reversing direction of fan rotation

The direction of fan rotation can be reversed when the fan is stopped or running. To reverse the direction of rotation, press the Direction button, and then press the Memory/Enter button (as shown on the left). The associated Direction indicator will flash, indicating the pending change.

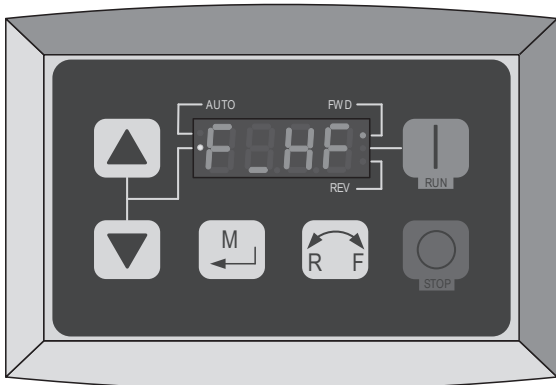

Typical Fault Message Display
(Incoming Line Over-Voltage Shown)

36 Additional Input Power Considerations

Controllers damaged by any of the conditions mentioned below may not be covered by Big Ass Fans warranty policy.

This section points out additional requirements that may be needed for the fan system to operate properly. To encourage a trouble-free fan system, additional input considerations should be addressed prior to installation.

Input voltage irregularities

⚠ CAUTION: One device is required for each fan controller.

The fan controllers are suitable for direct connection to input power within the rated voltage of the fan controller, but are sensitive to rapid changes in supply voltage. Below are certain input power conditions that may cause nuisance tripping, such as Overvoltage and Undervoltage faults. If any of the conditions exist as described below, you can install one of the devices listed under the heading "Corrective Action" on the input side of the fan controller.

Input power condition	Corrective action
Low line impedance (less than 1% reactance)	Install line reactor. Consult your Big Ass Fans representative for recommended part number.
Line has power factor correction capacitor	
Line has frequent power interruptions (voltage sags or swells)	
Line has intermittent noise spikes in excess of 6000V (lightning)	
Phase-to-ground voltage exceeds 125% of normal line to line voltage	Install Delta/Wye isolation transformer with grounded secondary (1:1 turns ratio).
Ungrounded distribution system	
Supply transformer exceeds established kVA limit	Install line reactor.
More than one controller per branch circuit	

Delta secondary

⚠ CAUTION: Care must be taken when connecting to a three-phase 240/120 V secondary as shown below. All fan controller models rely on internal references made between each incoming phase and ground. To prevent nuisance tripping such as Overvoltage and Undervoltage faults, 200–250 V, three phase fan controllers should be connected so that the High leg, or "phase B," terminates on "L2" of the fan controller's input power terminals.

⚠ CAUTION: Avoid installations utilizing supply transformers with a 480V delta secondary (ungrounded, corner grounded, open). Proper fan operation cannot be guaranteed due to a lack of proper phase-to-ground voltage references.

There are many different arrangements available for industrial and commercial power distribution in North America. The most common are the following:

- **575 V/330 V, Three-Phase (Wye Secondary).** Provides 575 V between phases, and 330 V from each phase to Neutral/Ground.
- **480 V/277 V, Three-Phase (Wye Secondary).** Provides 480 V between phases, and 277 V from each phase to Neutral/Ground.
- **208 V/120 V, Three-Phase (Wye Secondary).** Provides 208 V between phases, and 120 V from each phase to Neutral/Ground.
- **240 V/120 V, Three-Phase (Delta Secondary).** Provides 240 V between phases for three-phase loads, 120 V from phase "A" and "C" to Neutral/Ground, and 208V from phase "B" to Neutral/Ground as shown below. In this transformer arrangement, phase "B" is commonly referred to as a "Wild Leg" or "High Leg," and shall be marked accordingly with an orange finish or other effective means per NEC 110.15.

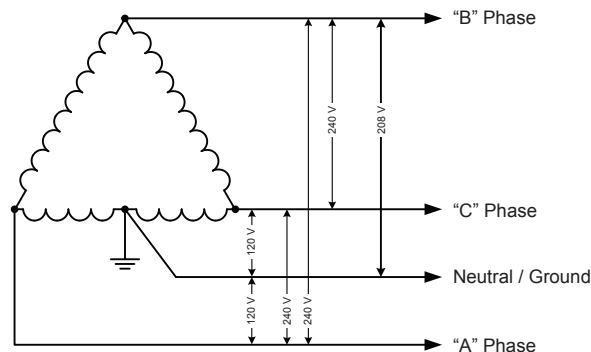

Branch circuit protection

CAUTION: Fan controllers may not be daisy chained on a branch circuit without providing either one fused disconnect or circuit breaker per controller.

The fan controller does not contain individual branch circuit over-current protection. Local code and/or NEC requirements may not permit installation of multiple fan controllers on a shared feeder. Confirm prior to installation.

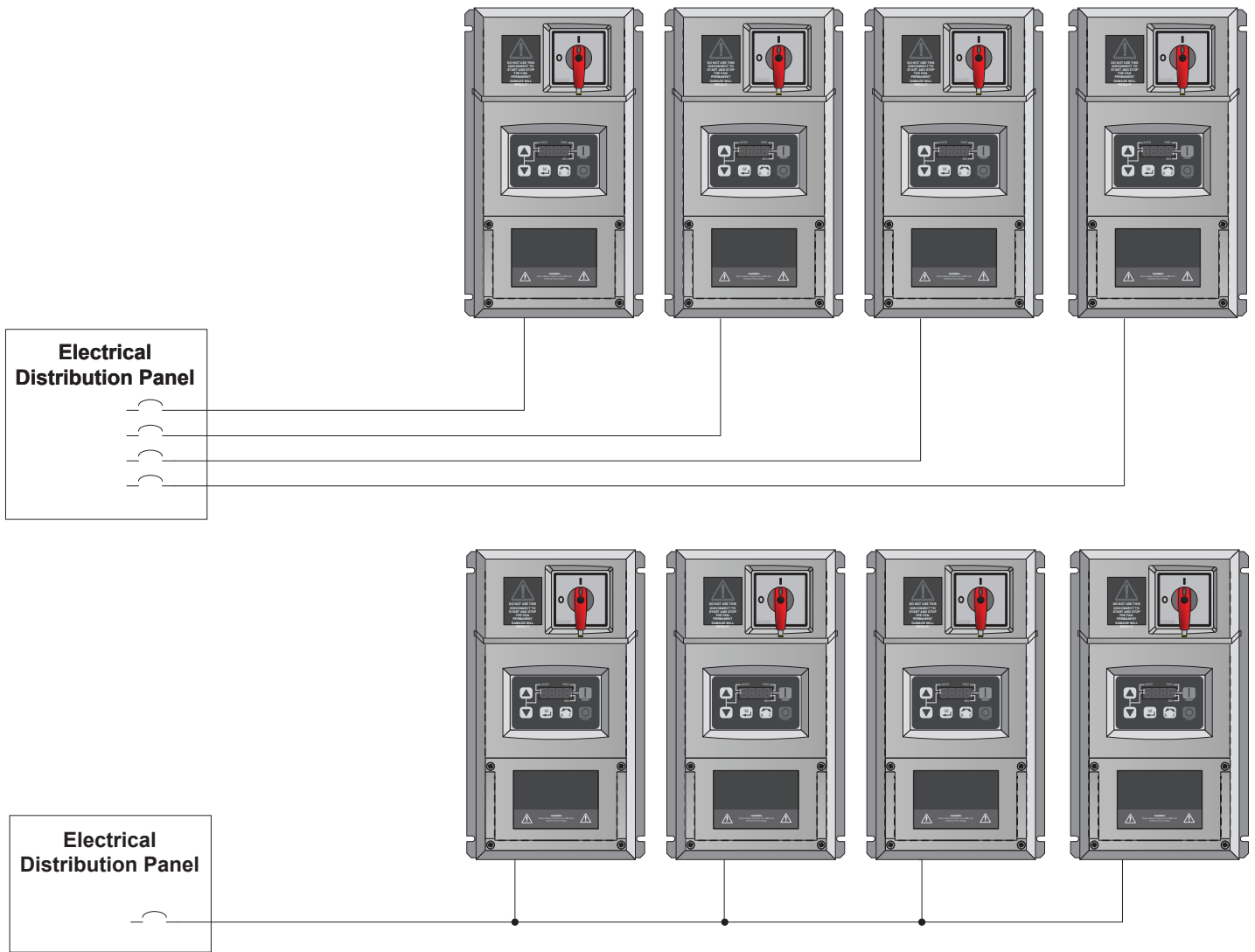

38

Operating the Fan

Big Ass Fans are the highest quality, most meticulously engineered HVLS fans on the planet, moving a lot of air with their size, not speed. Moving at a low speed means less energy used for operation, translating into more energy savings year-round. Follow the procedures below to ensure the most efficient operation of your Big Ass Fan.

To ensure proper fan rotation:

1. Turn on the fan.
2. Verify that the fan is rotating in the counterclockwise direction (when viewed from below).
3. If the fan is not rotating counterclockwise, reverse the direction of rotation. See page 35 for instructions on changing the direction of rotation.

Heating season

The Basic 6 fan returns heat from the ceiling to floor level more efficiently than small ceiling fans. For maximum energy savings, the fan should be operated continuously during the heating season and should not be operated in reverse (clockwise). Big Ass Fans are designed to operate efficiently at very low speeds, so turning the fan very slowly in the forward direction (counterclockwise) will provide enough air movement to circulate the hot air at the ceiling down to the floor without causing drafts.

Adjust the fan speed to the appropriate starting fan speed listed in the table below.

Floor-to-ceiling height (ft)	Starting fan speed	Display %
<40	15 Hz	20–30%
≥40	20 Hz	30–40%

Stand directly below the tips of the airfoils with hand outstretched. If you feel a draft, slightly decrease the fan speed (0.5). Repeat until the draft is no longer noticeable.

Cooling season

The cooling effect created by the breeze from the Basic 6 fan keeps occupants comfortable with the thermostat at a higher setting. During the cooling season, every degree higher that the thermostat is reset reduces the energy consumed by the air conditioner by 1.5–2%. To minimize energy usage during the cooling season, operate the fan only when building occupants are present.

Adjust the fan speed to the appropriate starting fan speed listed in the table below.

Floor-to-ceiling height (ft)	Starting fan speed	Display %
<40	25 Hz	40–50%
≥40	40 Hz	60–70%

Increase the speed of the fan until desired air speed or maximum fan speed is reached. In air conditioned facilities, increase the thermostat setting by 2–7°F to save energy.

Preventive Maintenance

39

- ⚠ **WARNING:** Risk of fire, electric shock, or injury to persons during cleaning and user-maintenance! Disconnect the appliance from the power supply before servicing.
- ⚠ **WARNING:** Before servicing or cleaning unit, switch power off at service panel and lock the service disconnecting means to prevent power from being switched on accidentally. When the service disconnecting means cannot be locked, securely fasten a prominent warning device to the service panel, such as a tag.
- ⚠ **WARNING:** When service or replacement of a component in the fan requires the removal or disconnection of a safety device, the safety device is to be reinstalled or remounted as previously installed.

Please take a few moments each year to perform the following preventive maintenance inspection on your fan to ensure its safe and efficient operation. Before contacting Customer Service, try mending the issue using the troubleshooting procedures on page 43. If you have any questions, contact Customer Service. *Note: Actual installation setup may differ from picture.*

Annual preventive maintenance

Perform the following maintenance procedures each year using the "Maintenance Checklist":

1. Check for the presence of the safety cable and shackle. The cable should be wrapped around the I-beam/angle irons leaving as little slack as possible. The shackle should be securely tightened and located on the topside of the I-beam/angle irons.
2. Ensure all mounting bolts are present and torqued to 40 ft·lb (54.2 N·m). There are four bolts for direct mount installations, and 12 bolts for installations with extension tube.
3. Inspect motor terminations inside the junction box and tighten if necessary.
4. Check the gear reducer for oil leakage. If leakage is present, contact Customer Service.
5. Ensure all 12 bolts securing the airfoils to the fan are present and torqued to 29 ft·lb (39.3 N·m).
6. Ensure airfoils are secured to one another by airfoil retainers.
7. Ensure the bolts securing the winglets to the airfoils are securely tightened.
8. Inspect for signs of corrosion, discoloration, pitting, or flaking of metal.
9. Inspect the airfoils and hub for signs of damage or cracks.
10. Check guy wires (if installed) for fraying or damage.

General preventive maintenance

- Check all connections in the fan controller and tighten as needed. Using a vacuum, remove all dust and debris from the inside and outside of the controller.
- Verify proper fan rotation. The fan should be turning counterclockwise when viewed from the floor.
- Dust the airfoils, motor, and motor housing. If desired, use a gentle cleaner or degreasing agent to polish the foils. Do not use Clorox® or other chlorine based cleaners! This could result in the release of toxic/fatal fumes.
- Observe the motion of the fan during operation. The fan should not wobble or precess. If any wobble is noticed, ensure the mounting structure is rigid enough to support the fan and that the guy wires, if used, are sufficiently taut. If guy wires were not used, Big Ass Fans suggests installing them. Contact Customer Service.

- ⚠ **WARNING:** Do not operate a fan with missing or damaged components. Please contact Customer Service.

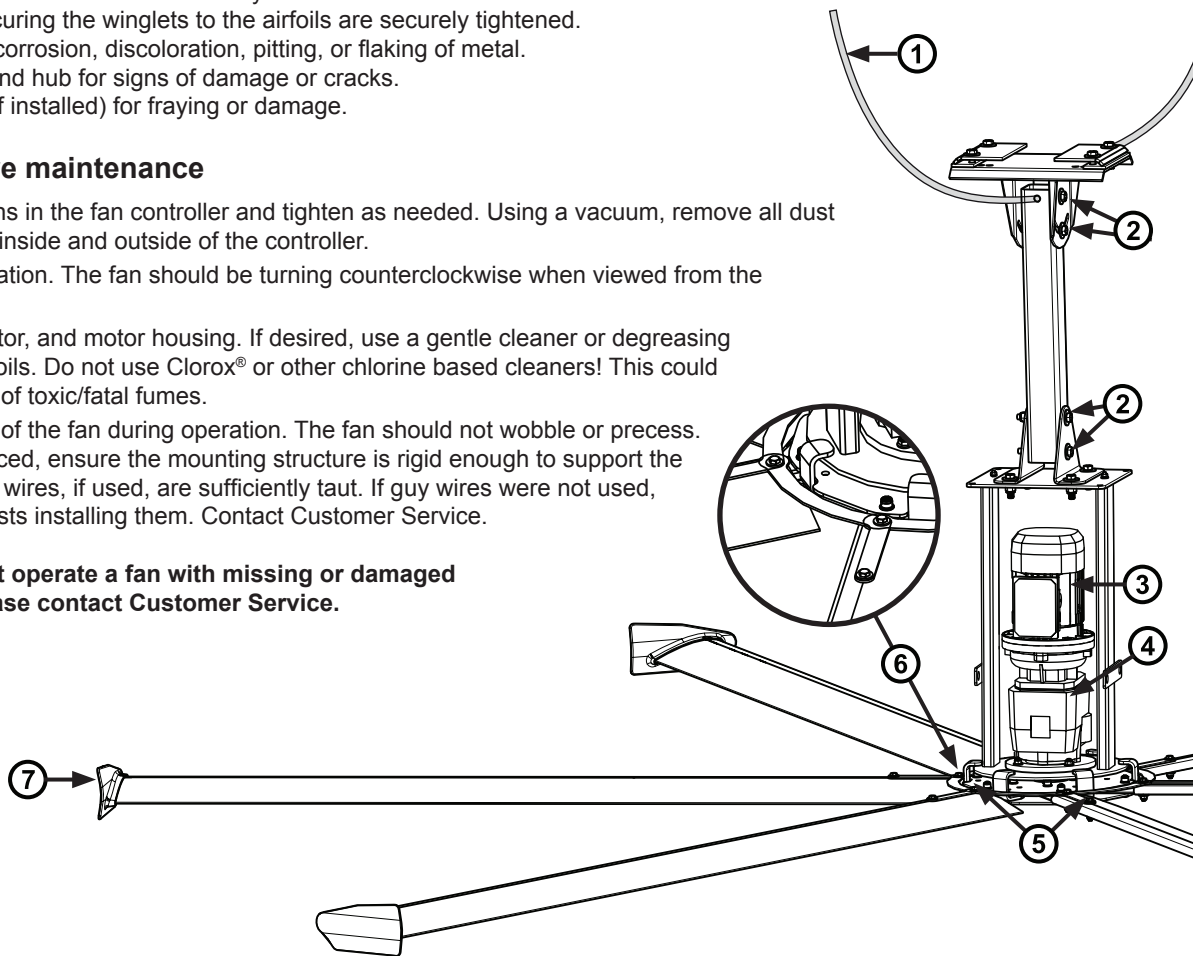

Troubleshooting

Customers in the United States

For questions about your product or customer service inquiries, please call our toll free number (877-BIG-FANS) or visit www.bigassfans.com/service.

Customers outside of the United States

For questions about your product or customer service inquiries, please contact your local Big Ass Fans representative or fill out a contact form at www.bigassfans.com/service.

Cutting the extension tube

⚠ CAUTION: Ensure the safety cable is not damaged after cutting and drilling the extension tube!

If your mounting structure requires a non-standard extension tube length, use the below guidelines to cut the extension tube.

IMPORTANT

Safety cable is attached here.
Do not cut or alter.

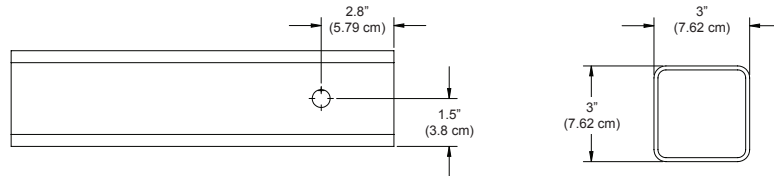

BOTTOM END—
CUT THIS END ONLY

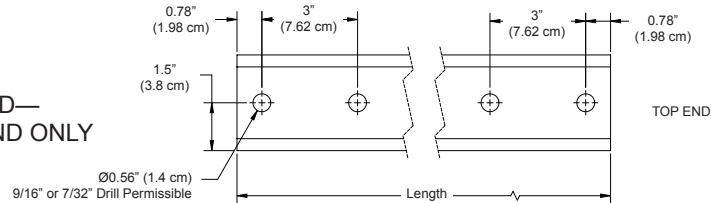

General troubleshooting











Some issues can be resolved before requesting service. Review the below troubleshooting tips before contacting Customer Service for support. *Note: Some motor, gearbox, or drive noise is to be expected and is normal.*

Symptom	Possible solution(s)
<i>The fan is turning in the wrong direction.</i>	To be effective, the fan should be rotating in the counterclockwise direction when viewed from the floor. If the fan is not rotating in the counterclockwise direction, press the F/R button on the controller.
<i>A popping noise is coming from the fan.</i> Airfoil noise comes from airfoils that are not tightened to the specified torque.	Disconnect the fan from power, and then tighten the airfoil fasteners to 29 ft-lb (39.3 N·m). If the popping still occurs, verify that the airfoils are not contacting each other. If they are, contact Big Ass Fans Customer Service.
<i>The fan will not start.</i>	Verify the following: <ul style="list-style-type: none"> • Make sure that all wires are securely connected. • Verify that supply power is adequate and functional. <p>If the fan still does not start, contact Customer Service.</p>
<i>The fan controller generates radio frequency noise (RF).</i> Fan controllers generate RF noise in many ways, but this can be prevented using the proper wiring practices outlined in "Electrical Installation" (page 23).	Verify the following: <ul style="list-style-type: none"> • Do not run your controller and sensitive equipment on the same power line. • Ensure proper grounding at the motor, controller, and from the controller to the utility. <p>If the noise is still present, contact Customer Service.</p>
<i>The motor makes noise when fan speed is increased.</i> Audible high frequency carrier noise may be an indicator of a stall condition.	Verify motor currents are within limits. See the fan specifications on page 2.
<i>The fan wobbles during operation.</i>	<ul style="list-style-type: none"> • Verify that the mounting structure is rigid enough to support the fan and that the fan is not being exposed to external air forces. • If guy wires were installed, confirm proper installation. If guy wires were not installed, contact Big Ass Fans Customer Service.





Troubleshooting the fan controller

Some controller issues can be resolved before requesting service. Review the below warning and fault messages and diagnostics before contacting Customer Service for support.

Status and warning messages

Message	Description
	<p>EPM Contains Earlier Firmware Version <i>This error will appear when you try to change a VFD parameter and the EPM firmware is older than the VFD's firmware.</i></p> <p>To correct this condition, press the STOP button, and then press the Memory/Enter button. Use the UP/DOWN button to scroll to P199. Press the Memory/Enter button. Use the UP/DOWN button to scroll to a setting of 5. Press the Memory/Enter button to save the change. The VFD is now able to read/write the EPM properly.</p>
	<p>Current Limit Verify proper motor wiring and HP. Check for short circuits. Increase acceleration time.</p>
	<p>Decel Override <i>Fan is stopping too fast, causing a DC Buss overvoltage. Drive is backing off the deceleration rate to prevent HP (Over-voltage) fault.</i></p>
	<p>Error <i>Invalid data or invalid command entered.</i></p>
	<p>Fast Current Limit Overload Check for short circuits throughout the load. Increase accel time.</p>
	<p>Flying Restart Attempt after Fault</p>
	<p>Program Attempt Made in OEM Settings Mode <i>(P199=1)</i> Parameter changes are not permitted.</p>
	<p>Reset EPM to OEM Defaults Failure <i>The EPM's OEM dataset is missing or corrupt.</i></p>
	<p>Fault Lockout <i>Auto restart failure after five unsuccessful restart attempts.</i></p>
	<p>Start Pending <i>The drive has tripped and is waiting to restart.</i></p>
	<p>Fan Stopped <i>Output frequency is 0 Hz.</i></p>

Fault messages

Message	Description
	<p>High Temperature fault Check for excessive load or a dirty heatsink. Improve the drive cooling ability.</p>
	<p>Assertion Level fault Check the assertion level switch relative to P120.</p>
	<p>Personality fault <i>Drive hardware error</i> Cycle power, and then reprogram EPM. If the fault will not clear, replace the drive and EPM.</p>
	<p>Control fault <i>Drive hardware error</i> Cycle power, and then reprogram EPM. If the fault will not clear, replace the drive and EPM.</p>

Fault messages (cont.)

Message	Description
F_cf	Incompatible EPM fault <i>Drive hardware error</i> Cycle power, and then reprogram EPM. If the fault will not clear, replace the drive and EPM.
F_EF	External fault Digital input programmed for this feature has been energized/de-energized depending on programming. P121-P124
F_F1	EPM fault <i>EPM is missing or defective.</i> Replace the EPM.
F_F2 to F12	Hardware Failure Replace the drive.
F_FoL	4-20 mA Signal Loss Check signal source and wiring, i.e., SmartSense wiring error.
F_GF	OEM Defaults Data Fault <i>The OEM parameters in the EPM module do not match the anticipated defaults according to the VFD. This fault may appear immediately upon VFD power-up.</i> To correct this condition , press the STOP button, and then press the Memory/Enter button. Use the UP/DOWN button to scroll to P199 . Press the Memory/Enter button. Use the UP/DOWN button to scroll to a setting of 0 . Press the Memory/Enter button to save the change. The VFD is now able to read/write the EPM properly.
F_HF	High Voltage fault Check AC incoming power or increase fan deceleration time.
F_LF	Low Voltage fault Check AC incoming power
F_OF	Output Transistor fault <i>Short circuit, excessive load, excessive cable charging current</i> Verify correct load (motor HP, motor wiring, cable length, cable type).
F_OF1	Motor Short to Ground
F_Pf	Motor Thermal OL Check actual motor current against FLA (P108)
F_rF	Flying Restart fault <i>Failed motor speed sync attempt</i>
F_SF	Single Phase fault <i>Incoming AC line phase loss</i> Check supply power.
F_UF	Start fault <i>Start command was present on powerup.</i> Cycle start command.

179 diagnostics running display options

Review the diagnostics below before contacting Customer Service for support.

Setting	Run screen display
P500	Fault History (n.xxx) N = 1-8 xxx = Fault code
P501	Software Version
P502	Drive ID
P503	Internal Code (x.yz)
P505	DC Buss Voltage (divided by 1.414 = approximate line input voltage)
P506	RMS Equivalent Motor Voltage at Drive Output Terminals
P507	Motor Load (% of drive output rating)
P508	Actual Motor Current in Amperes
P509	Torque as a Percentage of Motor Rated Torque (vector mode only)
P510	Drive Output Power in kW
P511	Total kWh for Drive Lifetime
P512	Heatsink Temperature Degrees Celsius
P520	0-10VDC Input Voltage (VDC)
P521	4-20mA Input Current (mA)
P525	Analog Output Level (VDC)
P527	Actual Drive Output Frequency (Hz)
P528	Network Speed Command (Hz)
P540	Total Runtime (hours)
P541	Total Powered-On Time (hours)
P550	Fault History (n.xxx) N = 1-8 xxx = Fault code

Warranty Return Instructions

47

Congratulations on your purchase of a Big Ass Fan! We are delighted that you have chosen our product to improve the quality of your indoor environment, and hope you'll have much pleasure using the fan for years to come.

Replacement of products under warranty return instructions

If you believe a part failed during normal operation and is covered under warranty, Big Ass Fans will ship a replacement part to you pursuant to your notice that you will be replacing the original part within 10 days. The replacement part will be shipped to you prior to our receipt of the item that failed, and prior to our evaluation of this part to determine the reasons for its failure and whether it is covered under warranty.

In order to evaluate the cause of the product failure, we will need you to return the original part to our offices within 10 working days of receipt of the replacement part. Should the part be covered under warranty, you will not be charged for the replacement item; however, you will be charged for the replacement part plus shipping if (1) the part is not under warranty because the source of failure is outside the scope of the warranty, or (2) the warranty period has expired. If there is no warranty coverage, we will send you a detailed letter of explanation. We also will charge you for the replacement item plus shipping and handling if you do not return the original item within 10 days of the receipt of the replacement item.

Instructions for returning the original item

1. Please use the return label that is included in the box containing the replacement part. The return shipment address is:

Big Ass Fan Company
ATTN: RMA# _____
800 Winchester Road
Lexington, KY 40505

2. Use the packaging for the replacement part to return the original part.
3. Include the packing list we have provided which includes the RMA#.
4. If the part weighs over 50 lbs., you will be provided a prepaid Bill Of Lading. To schedule a freight pick up, please contact Customer Service. We will only charge back the freight costs if the original part is not under warranty, or if you do not return the original component within 10 days of receipt of the replacement.
5. If the part weighs 50 lbs. or less, please use the provided prepaid UPS Ground shipping label and drop off at your nearest UPS pickup location.

If you have questions, please contact us at 1-877-BIG-FANS.

48

Warranty Return Instructions (cont.)

Warranty claim form instructions

1. Complete Warranty Claim Form and Responsibility Agreement and fax them to 859-967-1695, Attn: Customer Service. These pages will be faxed back to you for your records. The Warranty Claim Form will include our acknowledgment and a Return Materials Authorization (RMA) number. **Do not return any item without first being assigned an RMA# by Big Ass Fans Customer Service.**
2. No more than 10 days prior to the date you have made arrangements to replace the component part, call Customer Service at 1-877-BIG-FANS to arrange for replacement component delivery and original component pickup. At that time, we will fax you a written acknowledgment of your call that includes a reminder of the return instructions. Note: Even if you are not able to replace the component immediately following your initial notice to us, returning the Warranty Claim Form and Responsibility Agreement will effectively stop the warranty clock from running. You can then make the product exchange when you are prepared to do so. However, the warranty period will continue to run until we receive these completed pages back from you, and no warranty will be honored without receipt of these pages within the warranty period. We will not send out any replacement part until you have called to let us know that you have scheduled installation of the replacement. This ensures that the replacement part is not lost or damaged while awaiting installation, and that you are not billed for the replacement because you have waited too long to return the original component (see Responsibility Agreement).
3. When you receive the replacement part, you have 10 working days to remove and replace the existing component and return it to us at **800 Winchester Road, Lexington, KY 40505**.
 - a. Upon receiving the replacement part, verify that replacement part order is correct. If order is incorrect or damaged, notify Big Ass Fan Company within 24 hours after receiving order.
 - b. Use care unpacking the replacement component, as you will need to use *both* the packaging from the replacement part and the packing list and a return address label included inside this packaging to return the original part. If the original packaging and return documents are not used, you will be responsible for any damage incurred in transit as well as any additional costs involved. **Note: The RMA# must appear on the outside of the box being returned. Items without an RMA# will not be accepted.**
 - c. Use the delivery service or one of the truck lines specified in the acknowledgement for return of the part. We will refuse receipt of any shipment that is returned via an unauthorized carrier. If you prefer, we can make all arrangements for delivery and pickup.
 - d. Fax a copy of the bill of lading or other tracking information to 859-967-1695 when the item has been shipped so that we know to expect delivery of the original part.
4. If we do not receive the original part back within 15 working days from the date you receive delivery of the replacement, you will be invoiced for the cost of the replacement part, plus freight, on Net 15 terms (see Responsibility Agreement), and this invoice will be due and payable. If you subsequently return the replacement part to us after payment has been made, we will refund any payment made for the replacement part, unless we subsequently determine that the part is not covered under warranty.



800 Winchester Road
Lexington, KY 40505
Phone: 1-877-BIG-FANS
Fax: (859) 967-1695
www.bigassfans.com

Warranty Claim Form

Name (print): _____ Signature: _____

Company: _____

Shipping Address: _____

City/State/ZIP: _____

Phone: _____ Fax: _____

Items Returned: _____ Date of Purchase: _____

Reason(s) for Returning Item (please provide detail, including length of time after fan had been in operation that problem was noticed, nature of problem, any attempts you made to remedy the problem, etc.):

ATTENTION: Do not return any item without first being assigned an RMA# by Big Ass Fan Company Customer Service Department. The RMA# must appear on the outside of the box being returned. Items without an RMA# will not be accepted.

Date Replacement Parts Should Be Shipped (if known): _____ (Please do not request shipment until you are prepared to install. You may call us at 1-877-BIG-FANS to arrange shipment when you have scheduled installation.)

Acknowledgment of Receipt of Warranty Return Notification
(to be completed by Big Ass Fan Company)

Acknowledged By: _____ Date: _____

RMA#: _____

Authorized Truck Line(s): _____



800 Winchester Road
Lexington, KY 40505
Phone: 1-877-BIG-FANS
Fax: (859) 967-1695
www.bigassfans.com

Responsibility Agreement

To: Big Ass Fan Company

The undersigned understands and acknowledges receipt of the Warranty Claim Form and Instructions and agrees that Big Ass Fan Company ("Big Ass Fan Company") has the right, upon receipt of returned merchandise, to make final determination as to whether this merchandise should be replaced at no cost under Big Ass Fan Company's stated warranty policy.

The undersigned further agrees that if Big Ass Fan Company determines that this merchandise does not qualify under its stated warranty policy, Big Ass Fan Company can invoice for the replacement merchandise, plus shipping and handling for the original part and all replacements, and such invoice will be paid within 15 days of receipt of the same.

The undersigned agrees to ship to Big Ass Fan Company's location at 800 Winchester Road, Lexington, KY 40505 all of the merchandise replaced by Big Ass Fan Company, including, but not necessarily limited to, defective or failed components, within 10 working days of the receipt of the any replacements.

The undersigned further agrees that if said replaced merchandise has not been shipped to Big Ass Fan Company within 10 working days, Big Ass Fan Company can invoice for the replacement merchandise plus shipping and handling, and the invoice will be paid within 15 days of receipt.

Signed: _____

Title: _____

For: _____
(Name of Company)

Date: _____



2348 Innovation Drive
Lexington, KY 40511
Phone: 1-859-233-1271
www.bigasssolutions.com

Check-In Procedure

(for Big Ass Fans Certified Installers Only)

ATTENTION: These items must be completed prior to any additional installation crew members entering jobsite or any installation material being unloaded.

Date: _____

Company: _____ Job Name: _____

Address: _____ Purchase Order No.: _____

City/State/ZIP: _____

Contact Name: _____ Phone: _____

E-mail: _____

****SEE THE FOLLOWING PAGE FOR NFPA 13 REGULATIONS****

<input type="checkbox"/>	Fan placement is to be in accordance with agreed upon original Scope of Work and Layout. If this is to change, please note change and consult Field Service Manager for approval.
<input type="checkbox"/>	Installation techniques have been discussed (type of conduit, L-brackets if required, mounting technique explained). If the extension tubes exceed 4 ft (1.2 m), guy wires are explained and fully understood.
<input type="checkbox"/>	Times in/out, duration, and schedule presented and accepted.
<input type="checkbox"/>	Time (please list the number of employees and total duration of jobs):
<input type="checkbox"/>	Safety rules and regulations have been brought to installer's attention (e.g., badges, safety harnesses, vests, hard hats, footwear, lock out/tag out, certification processes, work area free of trash and debris, etc.). If there are any areas that are forbidden or secure, they are brought to the supervisor's attention and instructed not to enter. If there are any special site conditions (i.e., open areas and operating machinery to be avoided), they are also brought to the supervisor's attention and instructed how to bypass the area if required. Safety Rules and Regulations listed:
<input type="checkbox"/>	The facility manager understands all electrical requirements, i.e., breaker size, voltage, brand, main panel space, and they are in accordance with original Scope of Work and Layout.
	Additional comments:

Check-In Procedure (cont.)

(for Big Ass Fans Certified Installers Only)

National Fire Protection Association Standard

In accordance with NFPA 13 Standard from the National Fire Prevention Association as referenced in sections 12.1.4 and 11.1.7: High Volume Low Speed (HVLS) Fans:

The installation of HVLS fans in buildings equipped with sprinklers, including ESFR sprinklers, shall comply with the following:

- The maximum fan diameter shall be 24 feet (7.3 m).
- The fan shall be approximately centered between four adjacent sprinklers.
- The vertical clearance from the fan to sprinkler deflector shall be a minimum of 3 feet (0.9 m).
- All fans shall be interlocked to shut down immediately upon receiving a water flow signal from the alarm system in accordance with the requirements of NFPA 72- National Fire Alarm and Signaling Code.

WARNING: The fan should not be installed unless the structure on which the fan is to be mounted is of sound construction, undamaged, and capable of supporting the loads of the fan and its method of mounting. Verifying the stability of the mounting structure is the sole responsibility of the customer and/or end user, and Big Ass Fans hereby expressly disclaims any liability arising therefrom, or arising from the use of any materials or hardware other than those supplied by Big Ass Fans or otherwise specified in the installation instructions.

If this installation will be performed outside the scope of work or not within the specifications of Big Ass Fans by customer's request, please provide specific details:

Please sign below if both parties agree that all aspects of this installation have been thoroughly explained and are of clear understanding and agreement of the installation to be completed.

Customer Signature: _____

Printed Name: _____ **Date:** _____

Contractor Signature: _____

Printed Name: _____ **Date:** _____

The supervisor is to hold all documents until the job is complete and send all forms back to Field Service Manager. This will consist of the service/work order, Check-In document, and Close-Out document. The installation crew will not receive payment until all forms are signed by the facility manager and the supervisor. These documents will then be forwarded to the Field Service Manager at Big Ass Fans.



2348 Innovation Drive
Lexington, KY 40511
Phone: 1-859-233-1271
www.bigasssolutions.com

Close-Out Procedure

(for Big Ass Fans Certified Installers Only)

Date: _____

Company: _____ Job Name: _____

Address: _____ Purchase Order No.: _____

City/State/ZIP: _____

Contact Name: _____ Phone: _____

E-mail: _____

****SEE THE FOLLOWING PAGE FOR NFPA 13 REGULATIONS****

The field crew supervisor and facility manager are to walk through the completed installation.

<input type="checkbox"/>	The installation is complete and on time in accordance with the original Check-In document. If not, explain:
<input type="checkbox"/>	Conduit runs are installed in accordance with the Check-In document, Scope of Work, and Layout. If not, explain:
<input type="checkbox"/>	The fans are correctly placed in accordance with both the Check-In document, Scope of Work, and Layout. If not, explain:
<input type="checkbox"/>	Breaker size and wire type are in accordance with the Check-In document, Scope of Work, and Layout. If not, explain:
<input type="checkbox"/>	All safety rules and regulations met in accordance with the Check-In document, Scope of Work, and Layout. If not, explain:
<input type="checkbox"/>	Fans have been running for over an hour and operate without visible defect or issue.
<input type="checkbox"/>	The fan is spinning in the correct direction (counterclockwise when viewed from floor).
<input type="checkbox"/>	Angle irons are securely fastened and are without any apparent problems in accordance with installation techniques discussed at check-in.
<input type="checkbox"/>	If extension tube is 4 ft (1.2 m) or longer, guy wires are in place and there is no evidence of a wobble.
<input type="checkbox"/>	Supervisor or contractor has supplied and explained the Installation Guide. If not, explain:
<input type="checkbox"/>	The supervisor or contractor has explained and I understand how to operate fan including starting/stopping, speed operation, and power disconnect. If not, explain:
<input type="checkbox"/>	Time in/out and duration are in accordance with Check-In document.
	Additional comments:

Close-Out Procedure (cont.)

(for Big Ass Fans Certified Installers Only)

National Fire Protection Association Standard

In accordance with NFPA 13 Standard from the National Fire Prevention Association as referenced in sections 12.1.4 and 11.1.7: High Volume Low Speed (HVLS) Fans:

The installation of HVLS fans in buildings equipped with sprinklers, including ESFR sprinklers, shall comply with the following:

- The maximum fan diameter shall be 24 feet (7.3 m).
- The fan shall be approximately centered between four adjacent sprinklers.
- The vertical clearance from the fan to sprinkler deflector shall be a minimum of 3 feet (0.9 m).
- All fans shall be interlocked to shut down immediately upon receiving a water flow signal from the alarm system in accordance with the requirements of NFPA 72- National Fire Alarm and Signaling Code.

WARNING: The fan should not be installed unless the structure on which the fan is to be mounted is of sound construction, undamaged, and capable of supporting the loads of the fan and its method of mounting. Verifying the stability of the mounting structure is the sole responsibility of the customer and/or end user, and Big Ass Fans hereby expressly disclaims any liability arising therefrom, or arising from the use of any materials or hardware other than those supplied by Big Ass Fans or otherwise specified in the installation instructions.

NOTE: The customer's initials are required as acknowledgement for the following instances:

- ___ Return Trip Required – Additional Charges Apply (Customer not Ready/Lift Issues)
- ___ Work Completed Outside Scope of Work (if applicable)
- ___ Installation Not Performed Per BAF Recommendations or Specifications For Any Reason
- ___ Customer Understands and Approves Additional Charges As Explained in amount of \$_____ (if applicable)
- ___ Other (Please Explain Below)

If any portion of this installation was performed outside the scope of work or not within the specifications of Big Ass Fans at any capacity or for any reason, please provide specific details below:

Signatures of both parties are required below to acknowledge that this installation has been completed to customer's satisfaction, to activate fan(s) warranty, and to issue payment to contractor (with required documentation):

Customer Signature: _____

Printed Name: _____ **Date:** _____

Contractor Signature: _____

Printed Name: _____ **Date:** _____

The supervisor is to hold all documents until the job is complete and send all forms back to Field Service Manager. This will consist of the service/work order, Check-In document, and Close-Out document. The installation crew will not receive payment until all forms are signed by the facility manager and the supervisor. These documents will then be forwarded to the Field Service Manager at Big Ass Fans.

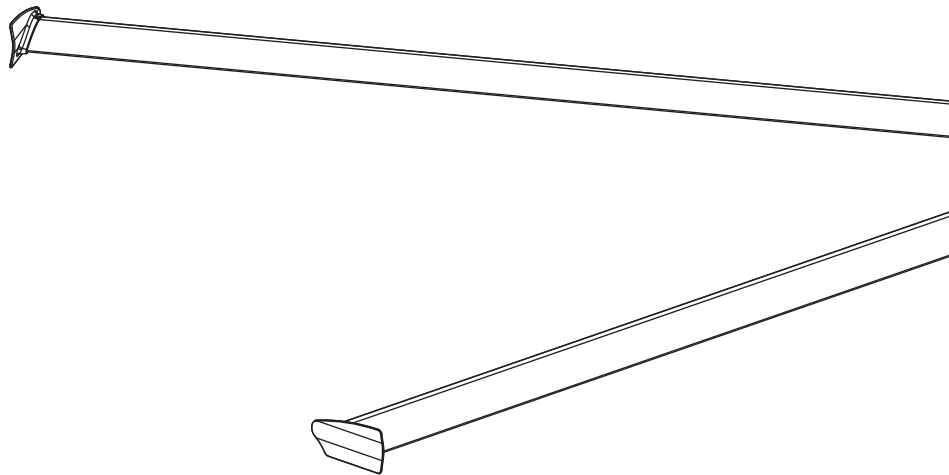

002781-01

REV. P



BIGASS[®]
FANS

2425 Merchant St., Lexington, KY 40511
1 (877) BIG-FANS | WWW.BIGASSFANS.COM