

CT4000 Make-Ready Requirements Specification

Introduction

This document provides best practices and guidelines for preparing a site to install EV charging stations (Make-Ready). “Make-ready” means that all necessary electrical infrastructure to operate the charging stations, all conduit and wire is pulled to the station location(s), all concrete work is completed properly so the stations can be mounted and any cellular repeaters are installed if required.

ChargePoint recommends that you plan for 5%-10% of parking spaces and 10%-15% for high EV adoption areas like California for future planning. Consideration of electrical infrastructure that supports current and future needs for EV charging will help avoid costly upgrades later as demands for EV charging grows.

Regardless of the specific type of CT4000 charging station you will be installing, these high level Make Ready specification will be the same.

ChargePoint recommends using a certified electrician to evaluate available capacity of existing electrical panels and to identify any electrical panel upgrades that may be required to support EV charging for multiple make-ready parking spaces. An onsite evaluation is necessary to determine conduit and wiring requirements from panel to proposed “make-ready” parking spaces, as well as to measure cellular signal levels and identify suitable locations for placement of any necessary cellular signal booster equipment.

Station Location

To help minimize costs you will want to choose station locations that are somewhat close to the available electrical infrastructure. In selecting these types of locations it helps minimize long conduit and wire runs as well as any trenching work. You should also consider locations where it will be easy to add future stations.

You also need to ensure that station locations have strong 3G cellular connectivity to allow ChargePoint to communicate with the stations. If there is a weak signal at the station location a cellular signal booster (repeater) will need to be installed (See the Cellular Signal Levels section later in this document).

Finally, consider how easy the stations are to find for drivers needing to access them.

EV Make-Ready Construction

All construction must conform to all local codes that are designated by the state, local municipality or authorities of where you are performing the construction. Conduit and wire size will need to be determined based on the length of runs from electrical panel to the station location. The National Electrical Codes and local codes will help determine appropriate sizing.

Each Level 2 charging port requires a dedicated single-phase electrical circuit (32A @ 208/240V) with 40A circuit breaker at the electrical panel. A certified electrician must install all electrical circuits in accordance with local and National Electric Code requirements.

General guidelines for “make-ready” include:

- 1) Evaluation of existing electrical infrastructure to determine if there is sufficient existing utility service and electrical panel capacity and identify costs for any necessary upgrades and/or a new dedicated electrical panel.
- 2) For installation of dedicated EV electrical panel, choose panel location in close proximity to existing electrical supply.
- 3) Identify station locations for EV charging that are in close proximity to an electrical room with common area electrical panel; reduce distance for conduit runs and electrical wiring from electrical panel to all proposed EV parking spaces.
- 4) Determine the appropriate mounting location.
- 5) Ensure the wiring, circuit protection and metering is in place at the station installation location by reviewing the specification, wiring diagram and grounding requirements later in this document.
- 6) Ensure that you are using 6 or 8 gauge wire to station. If you will be feeding the station with larger wire like 4 gauge then you will need to splice the wire for 6 or 8 gauge.
- 7) If possible, avoid or minimize trenching requirements, especially more costly trenching to run conduit under asphalt surfaces.
- 8) Choose adjacent parking spaces in an area with adequate lighting and identify suitable locations with flat surface for wall mount stations or suitable floor surface for pedestal mount stations (no asphalt surfaces).
- 9) Use dual-port pedestal mount stations where possible in open areas for adjacent or tandem parking spaces.
- 10) Determine optimum conduit layout to minimize linear conduit costs to multiple EV parking spaces and size all conduit and electrical wiring in accordance with National Electric Code requirements.
- 11) Measure cellular signal levels for 3G Verizon and 3G AT&T carriers and identify optimum location for placement of ChargePoint gateway devices.
- 12) Ensure that adequate CDMA (Verizon, Sprint) or GSM (AT&T, Rogers) cellular coverage is available at the station installation location. To ensure adequate signal strength in underground or enclosed parking structures, cellular repeaters may be required. (See the Cellular Signal Levels section later in this document)
- 13) For below ground-level or enclosed parking garages, installation of a cellular signal booster often is required with indoor antenna located near gateway device and EV parking spaces and outdoor antenna typically located at the garage entrance ceiling or on the rooftop where cellular signal levels are optimum.
- 14) Determine cost budget options for make-ready electrical infrastructure to satisfy current needs and future needs. Prioritize locations for installation of charging stations based upon immediate and future needs, construction timelines, and costs.

For bollard mount charging stations, prepare the installation site by following the instructions in the Preparing Concrete Pad chapter. The mounting template for the bollard can be found at www.chargepoint.com/support-installation-guides.php. Ensure the PDF version is accurate by printing it

at 100% scale on 11" x 17" paper and then verify at least one dimension. (See also the Prepare the Installation Site for Bollard Mount later in this document)

Review the CT4000 Data Sheet (available at www.chargepoint.com/support-product-data-sheets.php).

It is recommended that only new 40A dual pole breakers are to be used. Used breakers can damage equipment and cause a fire risk.

Always check local codes to ensure compliance. You may need to adjust this specification to comply with codes that apply at your installation location.

If you have pre-existing infrastructure or are using your own preferred electrical contractor to prepare your site for charging, a Site Validation by a ChargePoint Operations and Maintenance (O&M) partner will be required to certify compliance with electrical specification requirements and to ensure that everything was prepared to ChargePoint specifications.

Cellular Signal Levels

ChargePoint charging stations communicate over the ChargePoint network via 3G cellular carriers to provide the following features to property managers and EV drivers:

- User authentication, access control, & billing
- Energy usage reporting
- Charging station utilization and charging session details for analytical reporting
- Real-time charging status to drivers using the ChargePoint mobile app or web portal
- Ability for drivers to start & stop charging sessions using the ChargePoint mobile app
- 24-hr driver support to remotely start charging sessions (ChargePoint cards also start & stop sessions)
- Text notifications to drivers when vehicle battery is full or stops charging
- Station fault alarms and remote diagnostic capability
- Over-the-air software upgrades for new station features or enhancements (future proof)

General guidelines when measuring cellular signal levels:

- Do not rely on cell phone apps to measure cellular signals when conducting site surveys
- Take 3G AT&T & 3G Verizon signal strength readings at exact proposed charging station locations
- Take cellular readings at location of where a cellular signal booster antennae will be installed to ensure there is enough signal to boost

Requirements for acceptable 3G AT&T and 3G Verizon cellular coverage are:

- Weakest acceptable signal levels at gateway device without using a signal booster are -85 dbm for 3G AT&T WCDMA & -90 dbm for 3G Verizon EVDO (ECL0 > -10 using Squid Pro 3G);
- For a cellular signal booster solution inside parking garages, the weakest acceptable signal level at outside antenna location should be between -95 dbm and -100 dbm (the weaker the signal the less coverage area inside using a signal booster);

Below are a few suggested options for cellular signal boosters:

- WeBoost 4G-X for all carriers in North America, supports voice, 2G, 3G and 4G, max gain of 70 db for up to 10,000 square feet of coverage area;
- SureCall Fusion 5 for all carriers in North America, supports voice, 2G, 3G and 4G, average gain of 65 db & max 72 db for up to 6,000 square feet of coverage area;
- SureCall Force 5 for all carriers in North America to provide up to 20,000 square feet of coverage inside parking structure.

ChargePoint O&M partners will validate acceptable cellular signal strength at the site using a cellular signal strength reader. We recommend using a Squid Pro 3G M2M signal meter from Berkeley Varitronics Systems to distinguish 2G vs 3G cellular carrier frequencies. For details concerning acceptable cellular signal levels and signal booster solutions, please reference Make-Ready Specifications section at the end of this document.

Electrical Panel

Level 2 charging stations are considered continuous load devices (EVs draw maximum load for long durations); and therefore, electrical branch circuits to EV chargers must be sized at 125% of the load in accordance with National Electric Code requirements. This means that for a maximum 32A @208/240V output to an electric vehicle, 40A breakers are required and wiring conductor ampacity sized in accordance with NEC code for continuous load devices. Typically, 6 AWG or 8 AWG insulated electrical wiring is used depending upon distance between the electrical panel and the charging station.

When planning for multiple EV charging stations, it is best practice to segment non-continuous and continuous loads, with all branch circuits for EV charging on a dedicated electrical panel assembly with 40A circuit breakers. When sizing new electrical panels dedicated for EV charging, all branch circuits will support continuous load, and the panel rating sized for at least 125% of the total load on each leg of a 3-phase panel.

Specifications

Electrical Input	SINGLE PORT			DUAL PORT		
AC Voltage	208/240VAC			208/240VAC		
	Current	Input Power Connection	Required Service Panel Breaker	Current	Input Power Connection	Required Service Panel Breaker
Standard	30A	One 40A branch circuit	40A dual pole (non-GFCI type)	30A x 2	Two independent 40A branch circuits	40A dual pole (non-GFCI type) x 2
Standard Power Share	n/a	n/a	n/a	32A	One 40A branch Circuit	40A dual pole (non-GFCI type)
Power Select 24A	24A	One 30A Branch circuit	30A dual pole (non-GFCI type)	24A x 2	Two independent 30A branch circuits	30A dual pole (non-GFCI type) x 2
Power Select 24A Power Share	n/a	n/a	n/a	24A	One 30A branch circuit	30A dual pole (non-GFCI type)
Power Select 16A	16A	One 20A Branch circuit	20A dual pole (non-GFCI type)	16A x 2	Two independent 20A branch circuits	20A dual pole (non-GFCI type) x 2
Power Select 16A Power Share	n/a	n/a	n/a	16A	One 20A branch circuit	20A dual pole (non-GFCI type)
Service Panel GFCI	Do not provide external GFCI as it may conflict with internal GFCI (CCID)					
Wiring - Standard	3-wire (L1, L2, Earth)			5-wire (L1, L1, L2, L2, Earth)		
Wiring - Power Share	n/a			3-wire (L1, L2, Earth)		
Station Power	8W typical (standby), 15W maximum (operation)					

Electrical Output

Standard	7.2kW (240VAC@30A)	7.2kW (240VAC@30A) x 2
Standard Power Share	n/a	7.2kW (240VAC@30A) x 1 OR 3.8kW (240VAC@16A) x 2
Power Select 24A	5.8kW (240VAC@24A)	5.8kW (240VAC@24A) x 2
Power Select 24A Power Share	n/a	5.8kW (240VAC@ 24A) x 1 OR 2.9kW (240VAC@12A) x 2
Power Select 16A	3.8kW (240VAC@16A)	3.8kW (240VAC@16A) x 2
Power Select 16A Power Share	n/a	3.8kW (240VAC@16A) x 1 OR 1.9kW (240VAC@8A) x 2

Functional Interfaces

Connector(s) Type	SAE J1772™	SAE J1772™ x 2
Charging Cable Length	18' (5.5 meters)	18' (5.5 meters) x 2
Overhead Cable Management System	Yes	
LCD Display	5.7" full color, 640x480, 30fps full motion video, active matrix, UV protected	
Card Reader	ISO 15693, 14443, NFC	
Locking Holster	Yes	Yes x 2

Safety and Connectivity Features

Ground Fault Detection	20mA CCID with auto retry
Open Safety Ground Detection	Continuously monitors presence of safety (green wire) ground connection
Plug-Out Detection	Power terminated per SAE J1772™ specifications
Power Measurement Accuracy	+/- 2% from 2% to full scale (30A)
Power Report/Store Interval	15 minute, aligned to hour
Local Area Network	2.4 GHz Wi-Fi (802.11 b/g/n)
Wide Area Network	3G GSM, 3G CDMA

Safety and Operational Ratings

Enclosure Rating	Type 3R per UL 50E
Safety Compliance	UL listed for USA and cUL certified for Canada; complies with UL 2594, UL 2231-1, UL 2231-2, and NEC Article 625
Surge Protection	6kV @ 3000A. In geographic areas subject to frequent thunder storms, supplemental surge protection at the service panel is recommended.
EMC Compliance	FCC Part 15 Class A
Operating Temperature	-22°F to 122°F (-30°C to +50°C)
Storage Temperature	-40°F to 122°F (-40°C to +50°C)
Operating Humidity	up to 85% @ +50°C (122°F) non-condensing
Non-Operating Humidity	up to 95% @ +50°C (122°F) non-condensing
Terminal Block Temperature Rating	221°F (105°C)
Maximum Stations per 802.11 Radio Group	10. Each station must be located within 150 feet "line of sight" of a gateway station.

Dual Circuit Wiring Diagram

The following illustration describes the wiring for installing a CT4000 on a dual circuit. Wiring for a single circuit installation is described on the next page. Grounding requirements are described on page 1-6.

NOTE: Requires two dedicated circuits, each with its own two pole 40 A breaker. See Appendix B for lower power operation options.

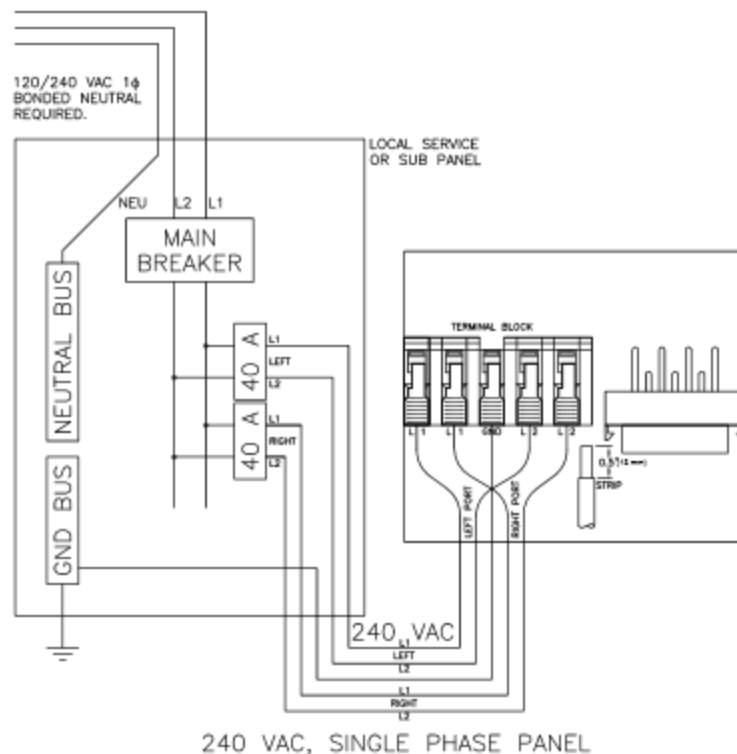
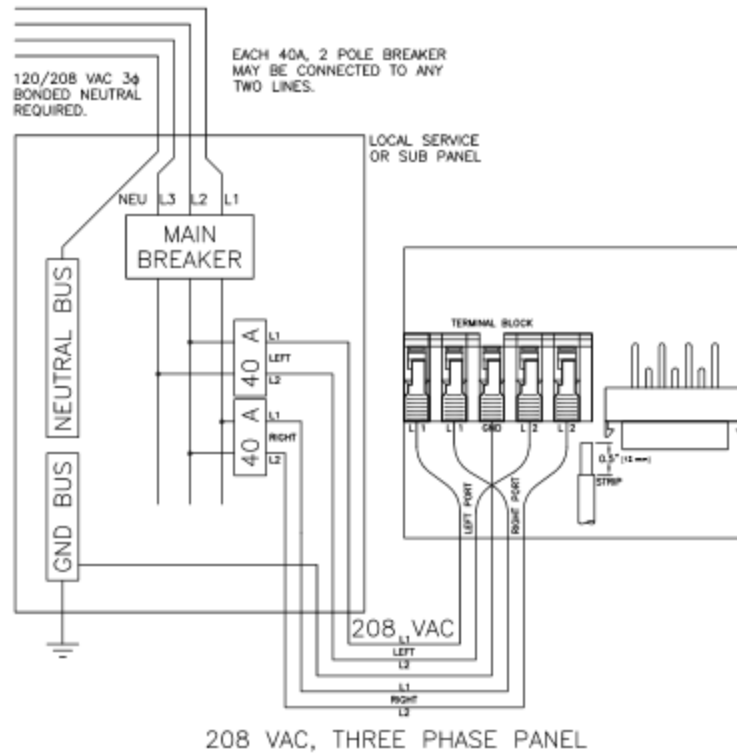

Single Port or Shared Power Wiring Diagram

The following illustration describes the wiring for installing a dual port CT4000 on a shared single circuit. For this installation, you will need the power sharing kit to allow both ports to share a two pole 40A circuit breaker. Wiring connections are provided in Appendix B. Grounding requirements are described on page 1-6. See Appendix B for lower power operation options.

Wiring for a dual circuit installation, see the previous page.

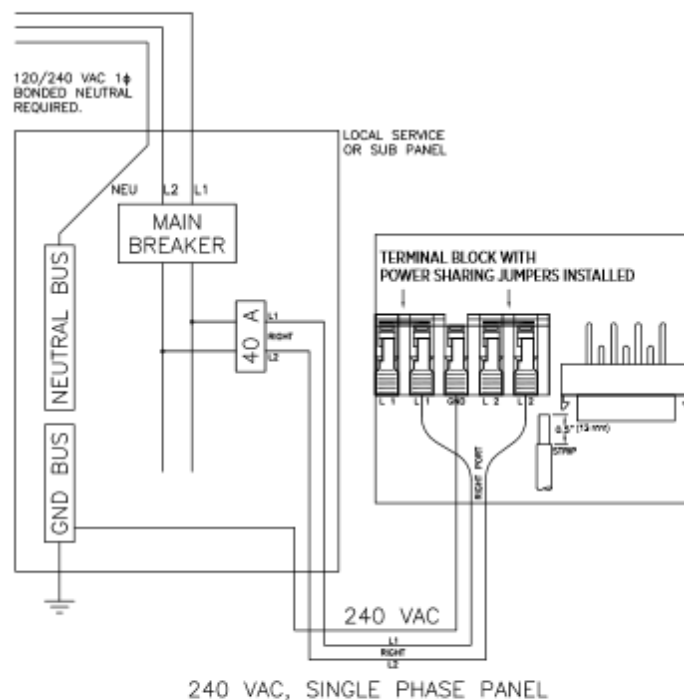
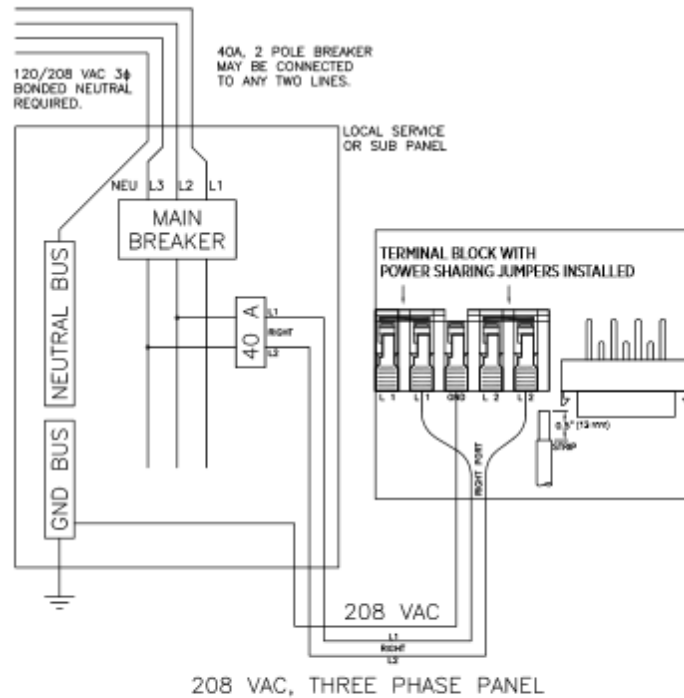

Grounding Requirements

The voltage of either line, relative to ground, must not fall below 80 volts or a Floating Line Connection error occurs (see page 5-3). Because the voltage of either line relative to ground must not be allowed to fluctuate, use only center-grounded systems. Neutral is not used to power the station but must be properly connected to ground, at the panel or transformer, to provide the necessary voltage reference relative to ground.

Connect to these systems

In a wye system, connect the station to ANY two lines, as shown below.

In a delta system, connect the station to a center-tapped secondary only, where the center tap is bonded and the station is connected to L1 and L3. This allows voltages to remain constant regardless of other loads that may be using the lines.

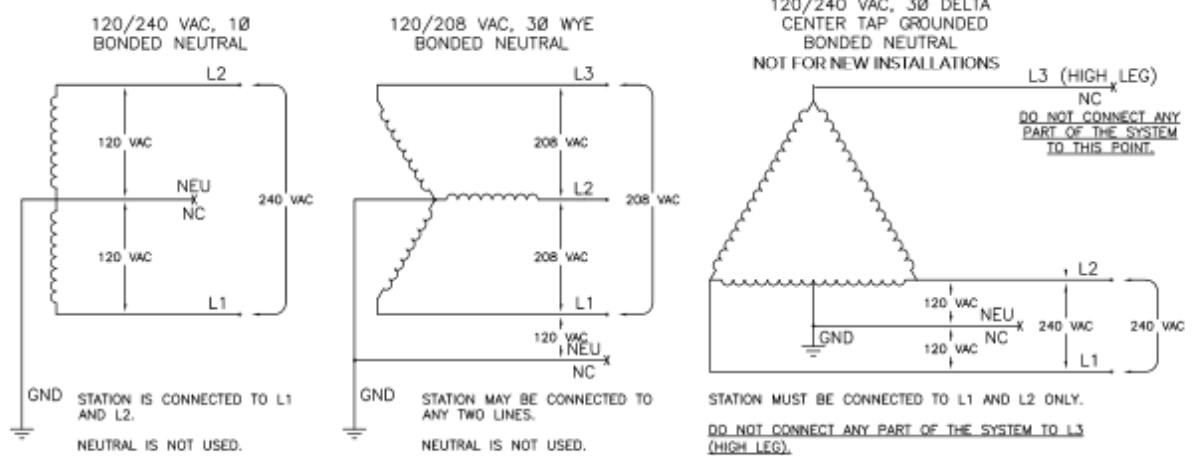

Do not connect to these systems

Do not connect ChargePoint stations to the following types of power sources:

- 120/208 VAC 3 phase wye, ungrounded
- 120/240 VAC 3 phase delta, corner-grounded
- Any system where the center point of the AC power source is not grounded

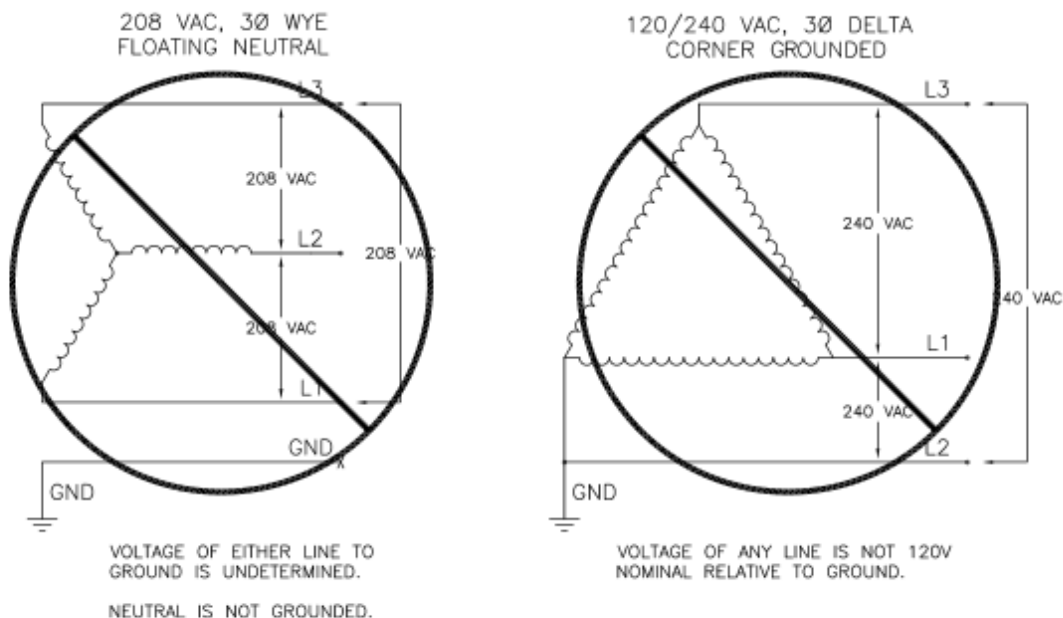

Preparing the Installation site for a Wall mount Station

When preparing the site for wall mounted stations, the conduit and wire must be brought to the location of the where the stations will be mounted. Below, are a couple images of sites showing how the conduit and wire was brought to the location where a wall mounted station will be installed. Flex conduit must be used to bring the wire to the station.



Preparing the Installation Site for a Bollard Mount

A

Before You Start

The ChargePoint® Charging Station's bollard mount can be installed either:

- into the ground
- onto an existing concrete surface (on an intermediate floor only)

The kit components you need to use, the tools required, and the installation steps vary depending on the type of installation. This appendix provides basic guidelines for both types of installations.

⚠ IMPORTANT: Always check local codes to ensure compliance. You may need to adjust the guidelines provided in this appendix to comply with codes that apply at your installation location.

Installation Overview

To install the CT4000 bollard mount into the ground, you will need the components shown below. These components can be purchased from ChargePoint by ordering a CT4000 Concrete Mount Kit.

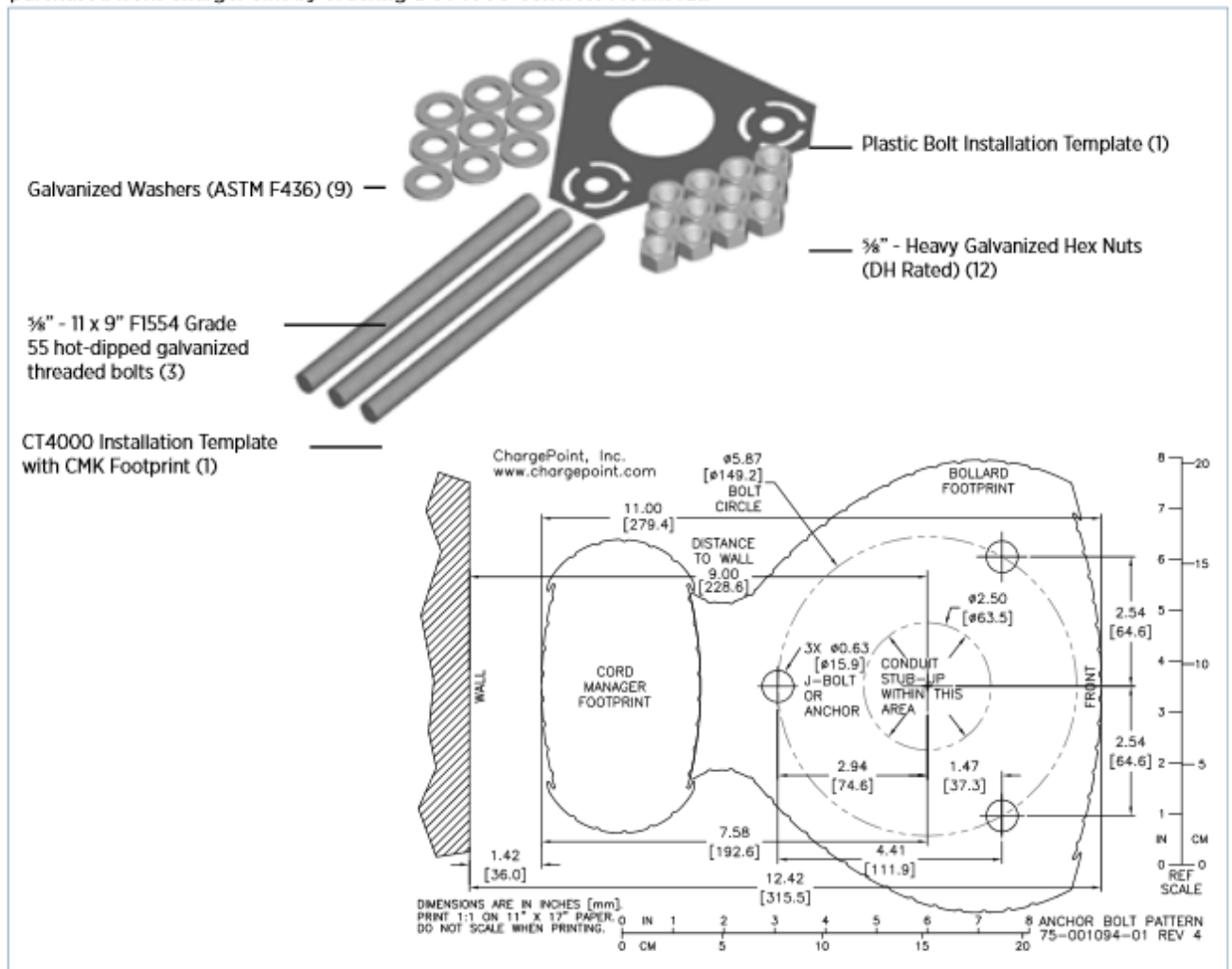

***NOTE:** When installing onto an existing concrete surface, you will need only 6 Galvanized Hex Nuts and 6 Galvanized Washers. But you will need several consumables as described on page A-3.

Casting into New Concrete

Before casting into new concrete, review the site for suitability to install a CT4000. The CT4000's Clean Cord Technology requires space behind the power stub-up for the Cord Management Kit (CMK). To ensure adequate space, refer to the illustrations below and to the CT4000 Installation Template (75-001094-01) included in this installation kit.

IMPORTANT:

- Always check local codes to ensure compliance. You may need to adjust these instructions to comply with codes that apply at your installation location.
- The concrete block must measure at least 24" on all sides.
- The bolt threads must extend 3" above the concrete.
- The conduit must be at least 1 1/2" in diameter and extend 12" to 24" above the concrete.
- Refer to the CT4000 Installation Guide for detailed installation instructions.

Kit Components Needed

You will need the entire contents of the CT4000 Concrete Mount Kit.

Follow These Steps

1. Install two nuts, with two washers captured between them, onto each of the three bolts, as illustrated. Lock them together so the lower end of the upper nut is located 6 - 6 1/4" from the bottom of the bolt. This sets the length of the exposed threads.
2. Insert the three bolts through the Plastic Bolt Installation Template. This ensures the relative position of the bolts and that the flange of the pole fits over the bolts.
3. On the bottom of each bolt, install a nut, a washer, and a nut. Lock the two nuts together so that the lower nut aligns to the bottom of the bolt.
4. Immediately after pouring the concrete, push the bolts into the concrete 6" deep, as illustrated. Ensure correct alignment and that the top 3" of the bolts remain exposed. Rotate the bolts as you insert them to draw concrete into the threads.

NOTE:

- It is important to rotate the bolts as you insert them. This allows the concrete to fully coat the threads of the bolts, reducing the amount of trapped air.
 - The Plastic Bolt Installation Template template can be left in place.
5. When the concrete is fully set, remove the upper nuts and one washer to install the bollard's mounting post.

You are now ready to install the CT4000's bollard mount. Refer to the CT4000 Installation Guide.

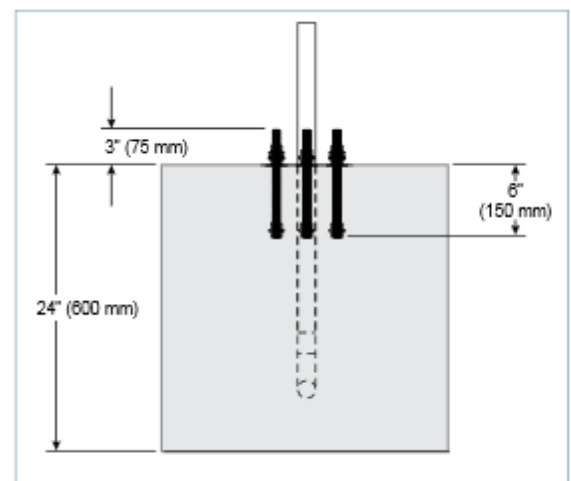
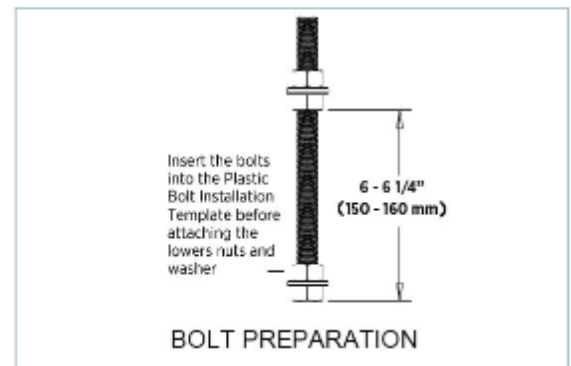

Installing on Existing Concrete

If installing on existing concrete, perform the following tasks:

- Review the site for suitability to install a CT4000. The CT4000's Clean Cord Technology requires space behind the power stub-up for the Cord Management Kit (CMK). To ensure adequate space, reference the CT4000 Installation Template (75-001094-01) included in this installation kit.
- Review the dimensions of the existing concrete slab. To safely mount a CT4000 charging station, the concrete must be at least 6" thick. At this thickness, all of the CT4000's mounting bolts must be positioned at least 15" from the front edge, at least 12" from the side edges, and at least 6" from the rear edge of the concrete slab.
- If an existing charging station is already in place at the installation site, turn off all power to the station and disassemble according to the original manufacturer's instructions. Cut away any existing bolts or non-power conduit stub-up to ground level. You may need to plug cut-away conduits at the slab end, and disconnect wiring at the other end.

IMPORTANT: Always check local codes to ensure compliance. You may need to adjust these instructions to comply with codes that apply at your installation location.

Kit Components Needed

The CT4000 Concrete Mount Kit contains 12 Heavy Galvanized Hex Nuts and 9 Galvanized Washers. You will need only 6 of each.

Tools Required

Electric drill or Hammer drill (½" chuck may be required depending on drill bits used) (1)

Consumables Required

These consumables can be ordered online directly from McMaster (McMaster Product #s are included in the table below). Delete any items you already have, and change quantities to accommodate the number of stations you are installing.

NOTE: The consumption rate of these products will vary depending on conditions at the installation site.

Quantity	McMaster Product #	Description	Purpose
1*	7505A55	Epoxy Adhesive for Concrete, 9.3 Ounce Cartridge (includes two mixing nozzles)	Filling drilled holes.
1*	7505A56	Mixing Nozzles for 9.3 Ounce Epoxy Adhesive for Concrete	Filling drilled holes. NOTE: You may need extra mixing nozzles to accommodate delays of over three minutes when applying epoxy.
1	7622T23	Ratchet Rod Caulk Gun with Half-Barrel Frame for 10-13 Ounce Cartridge, 6:1 Thrust	Filling drilled holes. NOTE: Any standard caulk gun will work.
1	7437K35	Electrical Cleaning and Maintenance Aerosol, Any Angle Spray Duster, 8 Ounce Net Weight	Cleaning drilled holes.
1	2960A22	Slow Spiral Round-Shank Masonry Drill Bit, ¾" diameter, ½" Shank, 10" Drill Depth, 12" Length Overall	Drilling ¾" holes in concrete. NOTE: The holes must be at least 6" deep.
1	28655A25	Drill Bit for Concrete Embedded Rebar, Round, ¾" bit size, ½" Shank diameter, 12" Length Overall	Drilling ¾" hole through rebar.
1	7221T13	Nylon Loop-Handle Brush, ¾" Brush Diameter, 3" Length Brush, 8 ½" Length Overall	Cleaning drilled holes.
1	9753K47	Push-on Round Cap, fits ¾" - 1 ¼" OD, ½" Inside Height, Packs of 100	Keeping the epoxy inside the drilled holes in situations where the slab is only 6" deep.

* Quantity based on installation of one charging station.

Follow These Steps

1. Install two nuts with two washers captured between them. Lock them together so the lower end of the nut is located 6" from the bottom of the bolt. This sets the length of the exposed threads.
2. Use the Plastic Concrete Bolt Installation Template to mark the hole locations.
3. Remove the template and drill three $\frac{3}{8}$ " diameter holes 6" deep into the concrete. When locating the template, consider the charging station's total footprint. For reference, a template for the CT4000 charging station with CMK is included in this kit.

NOTE:

- It is important that the bolts are parallel after installation. Therefore, ensure the drill holes are plumb by using a bubble level to check the angle of the drill after drilling 1 to 1 ½" .
 - If installing over existing buried conduit, position the center of the template around the conduit stub-up.
 - You may need two drill bits - one for the concrete (with the pilot) and another for the rebar (without the pilot). Always start the hole using the standard drill bit, then switch to the rebar drill bit only if drilling through rebar.
4. Remove all dust from inside the drilled holes using compressed air, or a vacuum and/or a brush.
 5. If the concrete slab is only 6" deep, insert a plug (McMaster Product #9753K56) in each hole to keep the epoxy in place until it hardens. Place the plug over the long end of a bolt and then use the bolt to push the plug to the bottom of the hole.
 6. Fill each hole with epoxy to about 2 ½" to 3" below the top. Continue immediately to the next step because the epoxy sets within about eight minutes.

NOTE: Inserting the threaded bolts displaces the epoxy, causing it to fill the holes to grade level. If the epoxy is below grade level, you can add more after the next step.

7. Place the Plastic Concrete Bolt Installation Template over the holes. This ensures the relative position of the bolts and that the flange of the pole fits over the bolts.
8. Insert the bolts through the template, into the holes. Rotate the bolts as you insert them to draw epoxy into the threads.

IMPORTANT: The epoxy is very thick. Therefore, it is important to rotate the bolts as you insert them. This allows the epoxy to fully coat the threads of the bolts, reducing the amount of trapped air.

NOTE: The installation template can be left in place.

9. If needed, top up the holes with epoxy to grade level.
10. Allow the epoxy to cure for at least 15 minutes* before removing the top nuts and washers.
11. Allow the epoxy to cure for 45 minutes* before applying torque to the nuts.

**Epoxy cure times assume you are using epoxy ordered from McMaster (Product # 7505A55). If using a different type of epoxy, you may need to adjust these times. Refer to the cure times provided with the epoxy.*

You are now ready to install the CT4000's bollard mount (see Chapter 2).

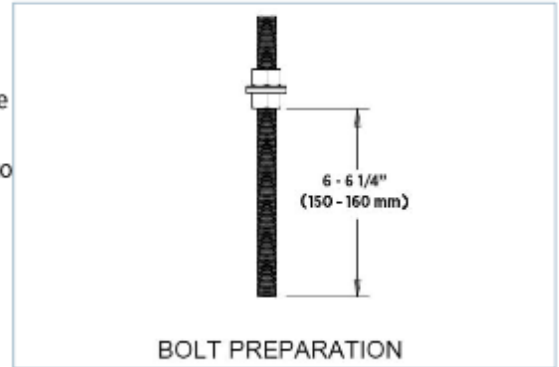

BOLT PREPARATION

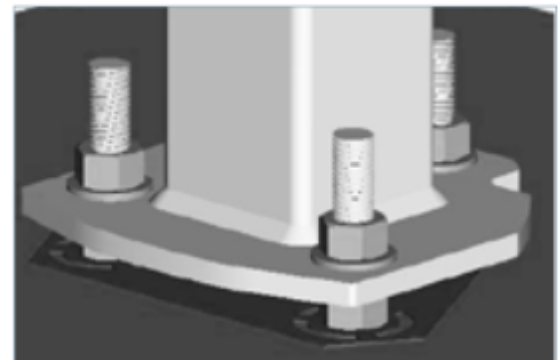
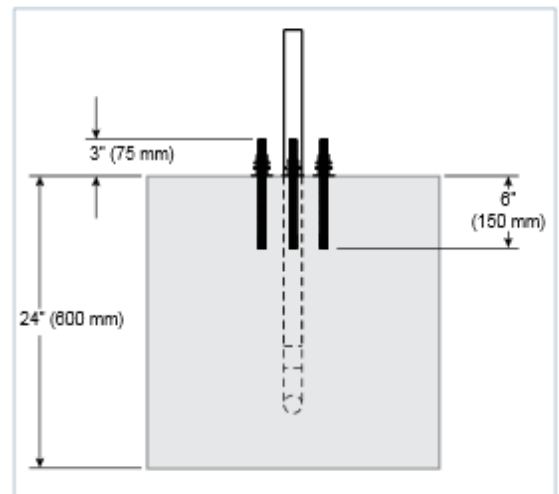



(Proper concrete pad with anchor bolts and conduit stub-up)