

S32K1xx Clock Calculator Guide

How to use S32K1xx tool to easily calculate device frequency domains

by: NXP Semiconductor

1 Introduction

The S32K1xx is NXP's 32-bit general purpose MCU family for automotive and industrial applications. Our offer combines the latest 90nm technologies so that customers will not have to compromise performance in exchange for low power consumption. The S32K1xx is built upon the ARM Cortex-M4®, running at up to 112 MHz. This device family consists of two subfamilies: S32K14x and the S32K11x. The S32K14x series is the performance-grade line, comprising the devices S32K142, S32K144, S32K146, and S32K148; while the S32K11x (S32K116 and S32K118) is the low-cost sub-family for users who wish to operate at a lower price point but with a reduced feature set. For simplicity's sake, this application note will refer to the S32K1xx family as "S32K".

This device supports four clock oscillators and, in S32K14x, one system phase locked loop (SPLL) for a total of up to five clock sources. There are also multiple input pins through which external clock signals can be driven into the MCU. Of the four oscillators, there is a system oscillator (SOSC), a 48 MHz fast internal RC oscillator (FIRC), a 2-8 MHz slow internal RC oscillator (SIRC), and a 128 kHz low power oscillator (LPO). The SOSC can source from either a signal driven into the EXTAL pin or a crystal oscillator connected to the XTAL and EXTAL pins (henceforth referred as simply "XTAL"). EXTAL can support up to 50 MHz, while there are two ranges that are allowed for the XTAL depending on configuration: 4-8 MHz or 8-40 MHz; FIRC can be trimmed to 48 MHz; SIRC can be either 2 MHz or 8 MHz. In addition, the SPLL on S32K14x devices supports frequencies from 90 MHz to 160 MHz. See the following table for a summary.

Table 1. S32K clock source frequencies

Clock Source	Allowed Frequencies
FIRC	48 MHz
SIRC	Selectable among 2 and 8 MHz
LPO	128 kHz
SPLL (S32K14x only)	90-160 MHz
SOSC	Selectable between XTAL and EXTAL
XTAL	Selectable ranges: 4-8 MHz and 8-40 MHz
EXTAL	Up to 50 MHz

Clock setup is a necessary step in almost all applications. The S32K clock calculator seeks to complement the configuration instructions in the reference manual by providing a graphical, interactive tool to help users find the correct register configuration in order to achieve their desired clock frequencies.

Accompanying this application note is the clock calculator. You can download it from [S32K1xx_Clock_Calculator](#).

Contents

1 Introduction.....	1
2 Clock calculator design.....	2
3 Clock tool example use case: Configure LPSPI to SPLL BUS_CLK at 48 MHz and peripheral clock at 24MHz FIRC in RUN mode on S32K14x.....	15
4 Conclusion.....	31
5 Revision history.....	31



Clock calculator design

The clock calculator makes use of macros to perform functions like resetting the spreadsheet to initial values, configuring all clock frequencies to the maximum allowable settings, and copying generated code. Macros must be enabled in the user's MS Excel to access these features. If macros are turned off however, the tool will still be able to calculate clock frequencies, but the aforementioned features will be disabled. To turn on macros in MS Excel 2016, go to the *Developer* tab on the top toolbar and click on *Macro Security*. A popup window will appear. In it, select *Enable all macros*.

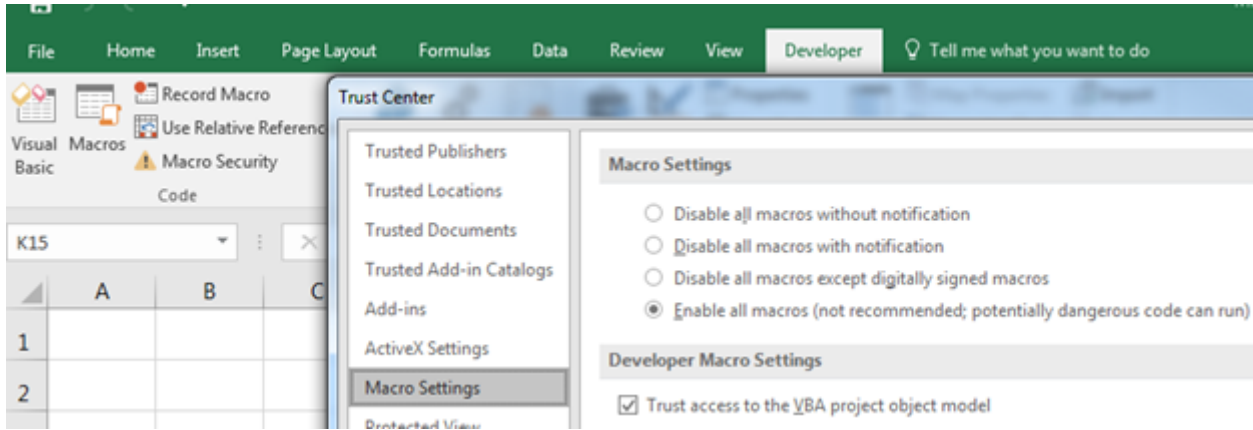

Figure 1. Enabling macros

2 Clock calculator design

The S32K clock calculator takes the form of an interactive Microsoft Excel spreadsheet, organized into multiple tabs as shown in the following figure.

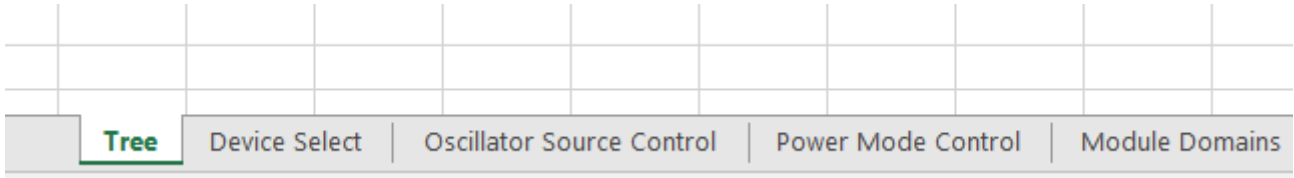

Figure 2. S32K1xx clock calculator setup

Clock sources (i.e. oscillators, SPLL, external input pins) propagate to the various clock domains from which the MCU modules take their clocks. Most cells representing clock domain frequencies are not to be modified manually. The user is meant to enter frequencies to the few select clock sources and all clock domain frequencies derive from these sources. Several clock domain inputs *are* meant to be modified manually as they represent external clocks that are driven into the chip. There are also input cells that set muxes and clock dividers. All cells that take user inputs have blue borders instead of black, shown below. Blocks that require inputs also show the register fields that the blocks represent.

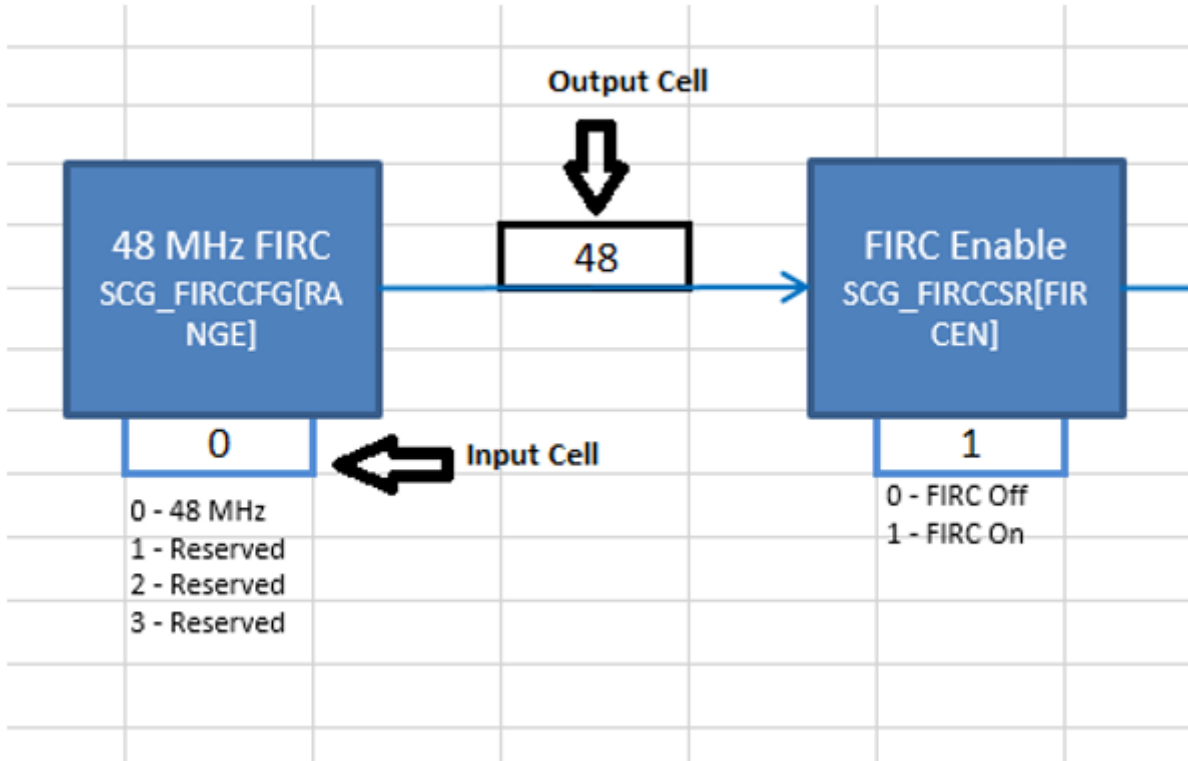

Figure 3. Input cells vs. Output cells

There are limits to what frequencies can be entered to the input frequency cells. Values that are out of range will be rejected and the user will receive an error message. Invalid clock domain frequencies that arise from valid input values and legal, but improper, dividers will be shaded in red. This is explained in greater depth later in this application note.

Frequency values are linked across tabs, so *BUS_CLK* in the *Tree* tab will always be the same as *BUS_CLK* in the *Module Domains* tab. Hyperlinks are provided to duplicate domain names to link back to their points of origin. For example, *BUS_CLK* originates in *Tree*. So clicking the *BUS_CLK* textbox in *Module Domains* will take the user to *BUS_CLK* in *Tree*. Textboxes that are links, when hovered over, will cause the mouse cursor to turn into a hand icon and a pop-up to appear, showing the address of the destination, as shown in the following figure.

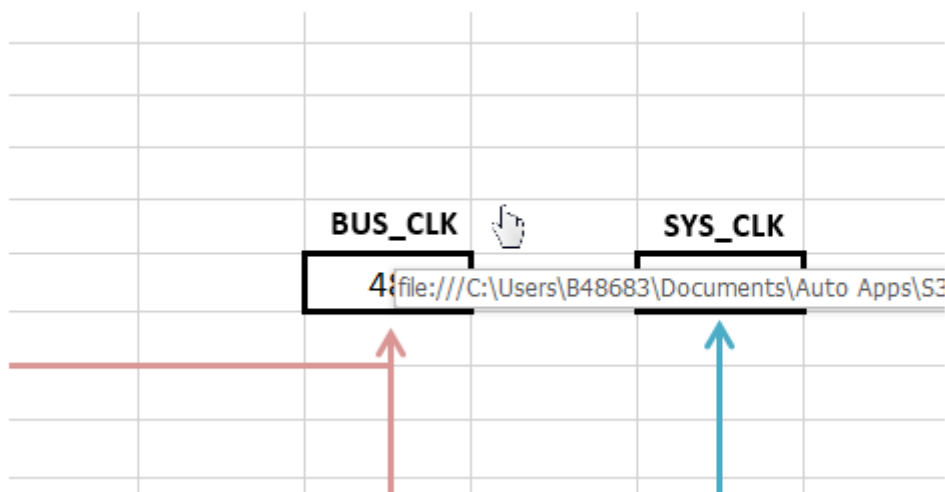

Figure 4. Clicking on a link

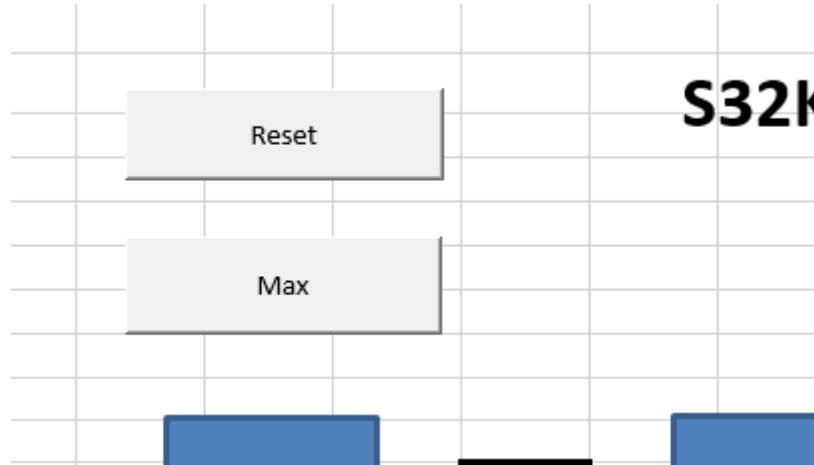

Figure 7. Buttons

2.2 Device select

The *Device Select* tab selects between the two S32K subfamilies. S32K11x lacks the SPLP, the HSRUN power mode, and several modules compared to the S32K14x. Since this tool visualizes the fully featured S32K14x, when S32K11x is selected, S32K14x-only features are turned off. This means that the SPLP output will be set to 0 and unavailable as a clock source, power mode blocks will be shaded red if the HSRUN power mode is selected, and S32K-only peripherals will have their clocks zeroed out as well.

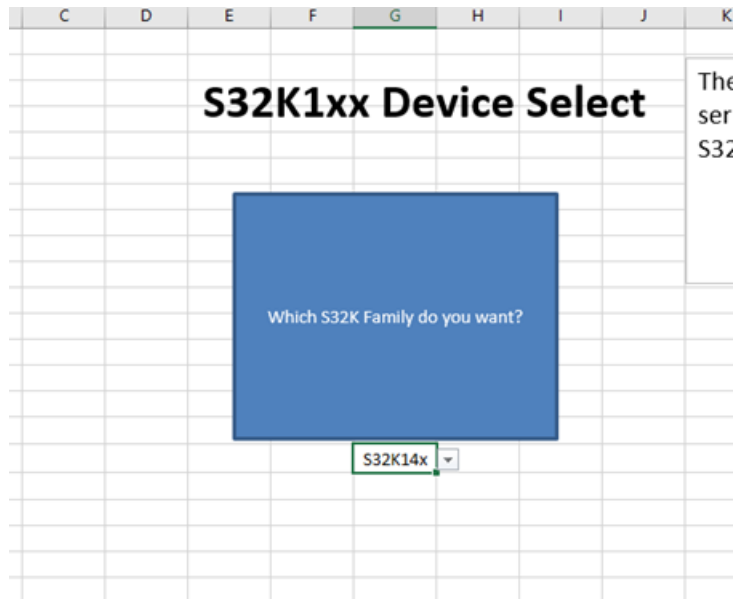

Figure 8. S32K device select

2.3 Oscillator source control

S32K’s external oscillators have a comprehensive set of options that warrants a separate tab. These features are reflected in the S32K clock calculator in the *Oscillator Source Control* tab. *Oscillator Source Control* contains the options for the SOSC and for the LPO. Below is a screenshot of the tab.

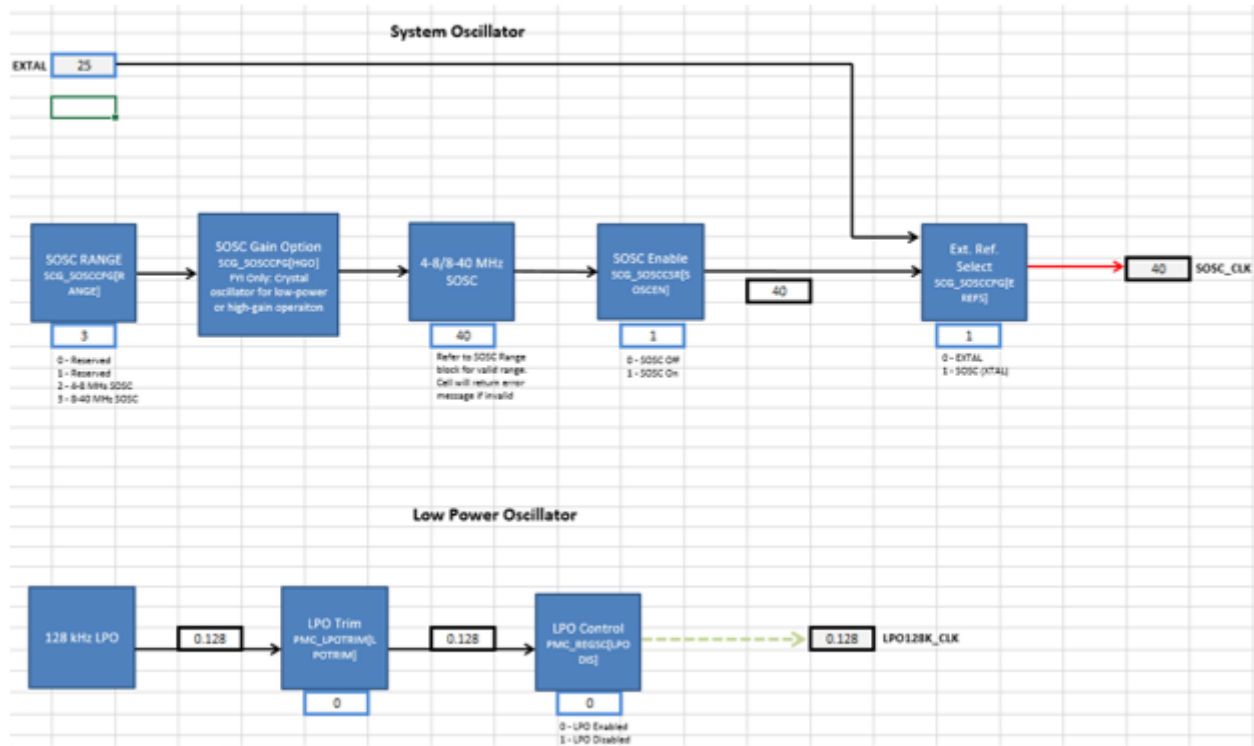

Figure 9. . Oscillator source control

For the system oscillator, this tab provides options for choosing the frequency range, enable/disable the oscillator, and selecting between XTAL and XTAL. The LPO control allows for frequency trimming, which is rated for 128 kHz, but can vary between 113 kHz and 139 kHz.

2.4 Power mode control

Since many clock domains are affected by the S32K system power mode, the power mode control options need its own tab. The figure below shows the power mode control sheet.

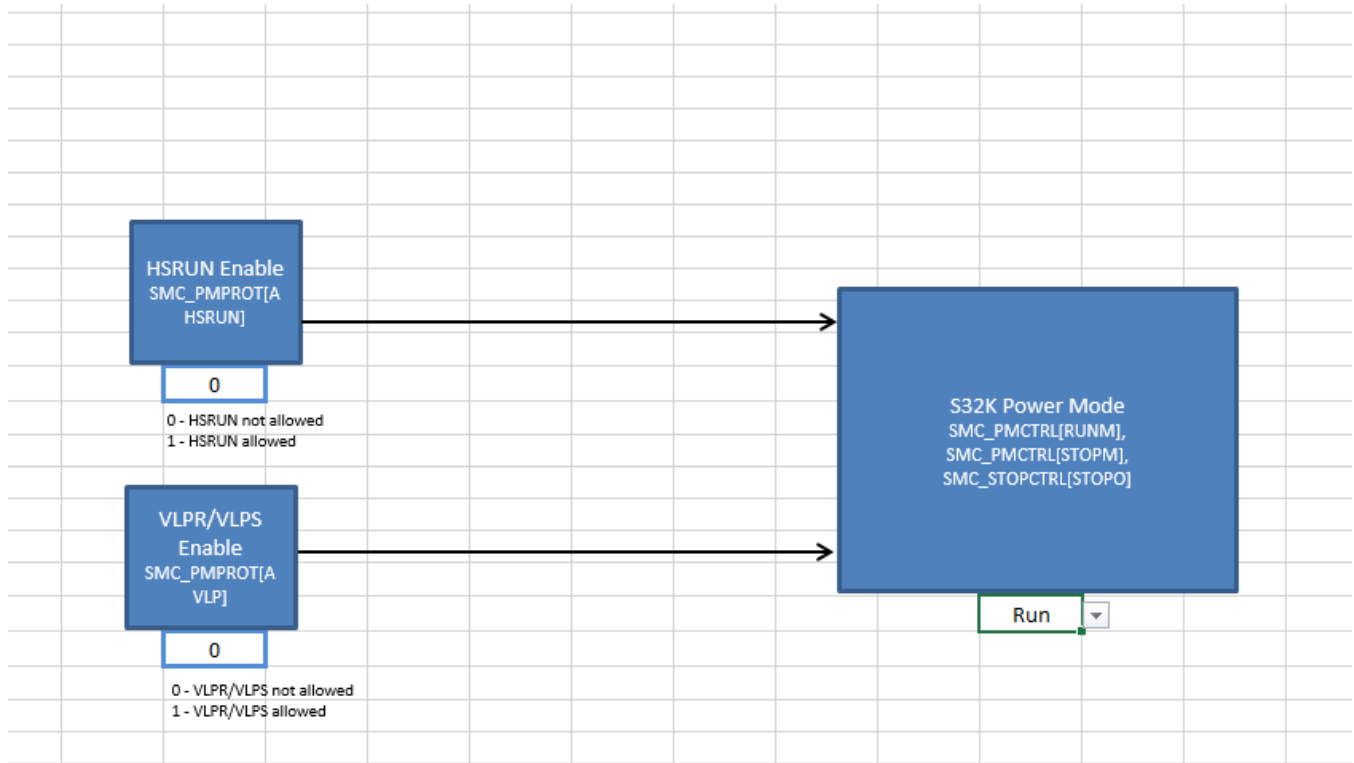

Figure 10. S32K power mode control

HSRUN and low power modes VLPR and VLPS need to be enabled in their own blocks, reflecting the S32K power management design. The list of options for *S32K Power Mode* will change, based on the setting of *HSRUN Enable* and *VLPR/VLPS Enable*. Note that S32K11x lacks an HSRUN mode, so if S32K11x is selected in the Device Select tab, the HSRUN Enable block has no effect, and HSRUN will not be available.

2.5 Module domains

The module domain tabs are an in-depth representation of the clocking for S32K modules. Where *Tree* leaves off at the clock domain level, the *Module Domain* tab picks up and progresses to the module level. A screenshot of *Module Domains* is shown in the figure below.

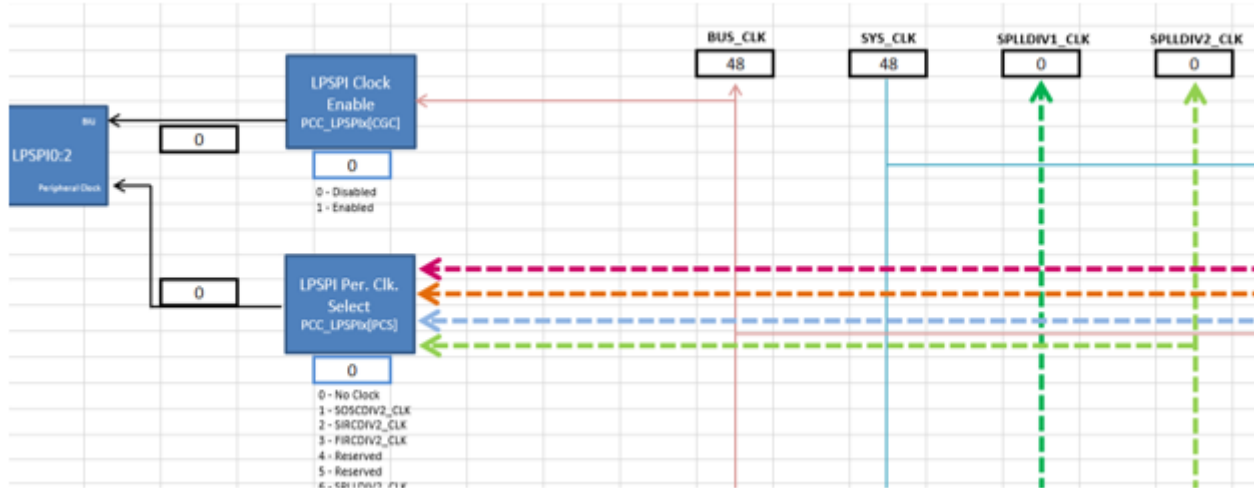

Figure 11. Module domains

The clock domains are color-coded. Black lines are reserved for local clock nodes. For example, *BUS_CLK* branches out to LPSPI, but is filtered through an *LPSPI Clock Enable* block. The arrow color after the block is changed to black to denote that the frequency value associated with that black line applies only to LPSPI. As a rule of thumb, clock domains are represented with black lines if all modules using it can fit within a single window without having to scroll.

2.6 SPLL

SPLL is a visual abstraction of the SPLL digital interface, as shown in the figure below.

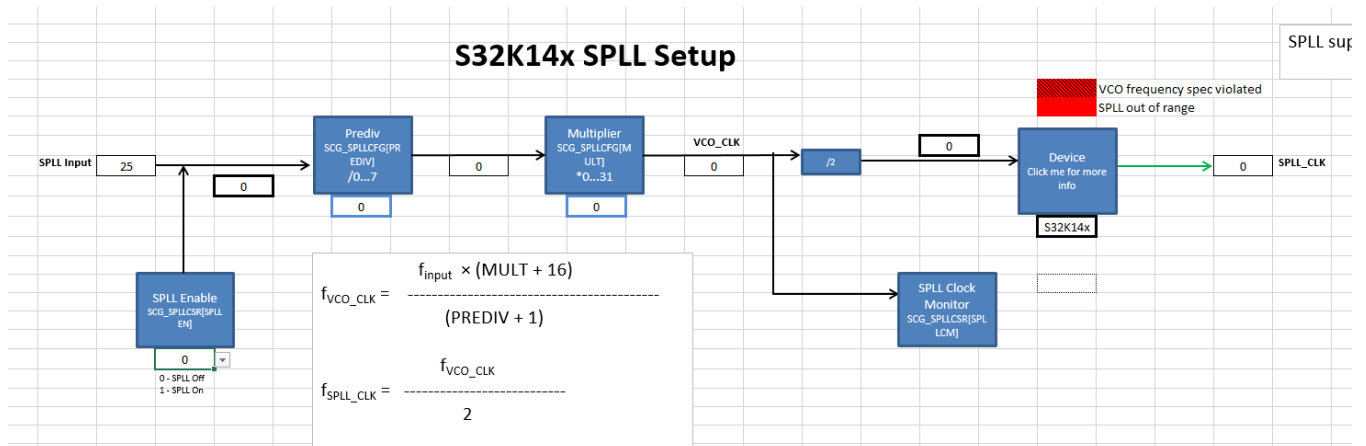

Figure 12. SPLL control

The input source of SPLL is the SOSC. Then, from the source, the dividers and multipliers located in the *SPLL* tab are set in order to achieve the SPLL output frequencies. The SPLL output frequencies are in turn propagated to the *SPLL_CLK* clock domain in the *Tree* tab. As mentioned in the previous sections, S32K11x lacks a PLL, so if S32K11x is selected in Device Select, *SPLL_CLK* will always be 0.

2.7 spll clk

The tab *spll_clk* is a reference table for the user to find the appropriate SPLL dividers and multipliers to achieve the desired SPLL frequency. Note that Columns A, B, and C of these tabs are frozen so if the table looks cut off, just scroll left or right.

SPLL frequencies are calculated from a reference frequency, a multiplier (MFD), and a prescaler (PREDIV). The SPLL reference is not manually configurable because there are a finite number of input values the SPLL can take; the SPLL will be whatever frequency SOSOC is configured for. SPLL reference therefore comes from the *Tree* tab. Once the SPLL reference frequency is selected, enter the desired SPLL output frequency. The reference table will then calculate the output frequency for each valid MFD and PREDIV setting. Like in the other sections, frequencies are color-coded to define which values are valid and which are not. Shading will change automatically once the output SPLL frequencies are calculated. MFD and PREDIV settings that achieve the exact desired frequency will be shaded in green, values that exceed the desired frequency, but are within S32K hardware specifications are marked in yellow, and frequencies that exceed the S32K hardware specification are colored red. Below is a screenshot of the reference table.

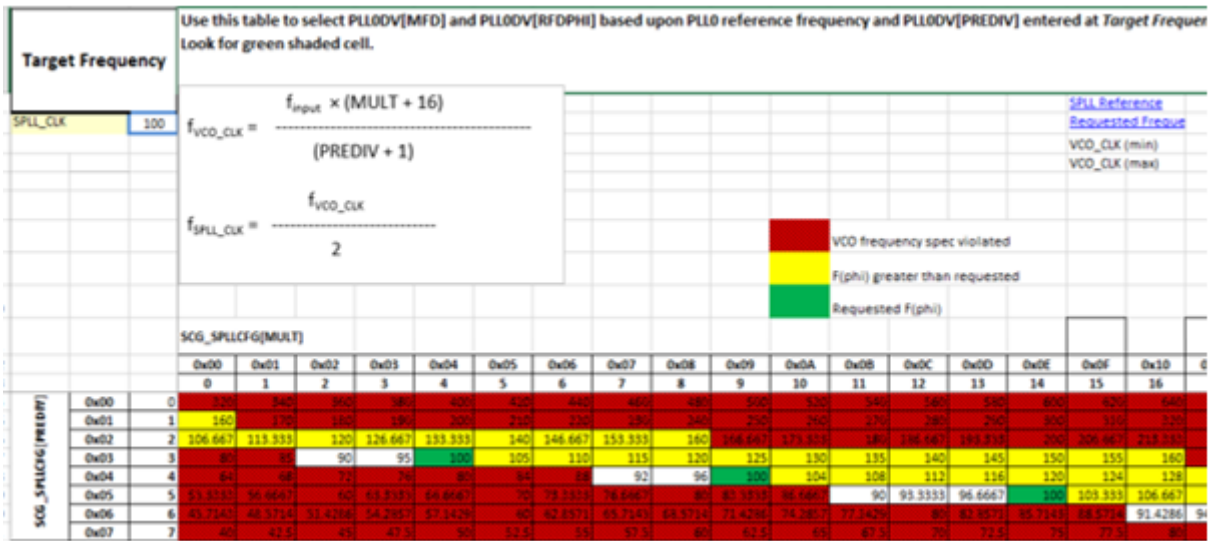

Figure 13. SPLL_CLK reference table

2.8 Detailed module diagrams (RTC, SAI, QSPI, ENET, FlexCAN)

Some modules such as the FlexCAN and QSPI have additional clock configuration options, which can get too large to fit into the Module Domains tab. Therefore the modules RTC, SAI, QSPI, ENET, and FlexCAN each have their own dedicated sheet. The following section shows the RTC. Its concept can be extrapolated to the other aforementioned peripherals. The *RTC* block inside *Module Domains* is a hyperlink to the *RTC Clocking* tab, shown below.

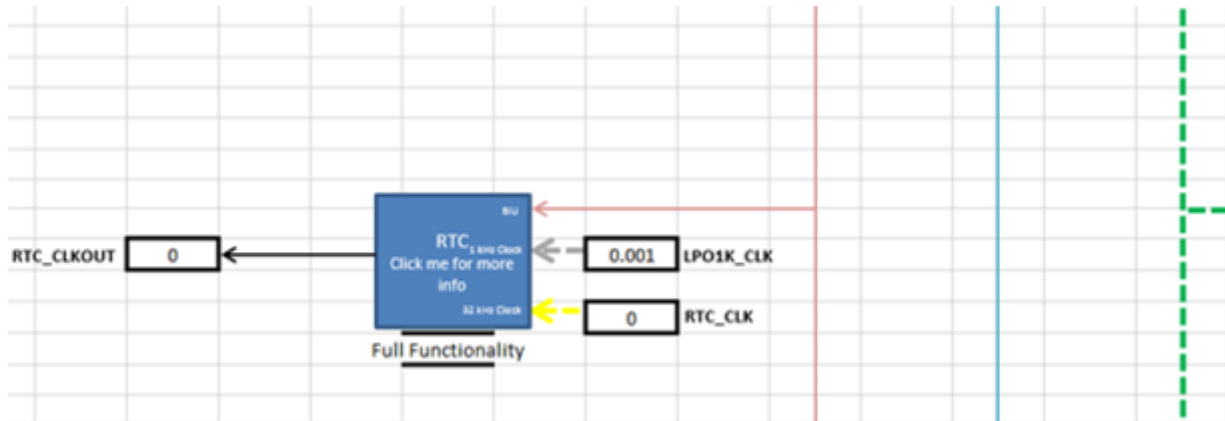

Figure 14. RTC module in module domains

The above figure shows that the module takes `BUS_CLK`, `LPO1K_CLK`, and `RTC_CLK` and outputs `RTC_CLKOUT`. *RTC Clocking* houses the actual RTC setup options that process these three inputs to produce `RTC_CLKOUT`. Below is a screenshot of the *RTC Clocking* tab.

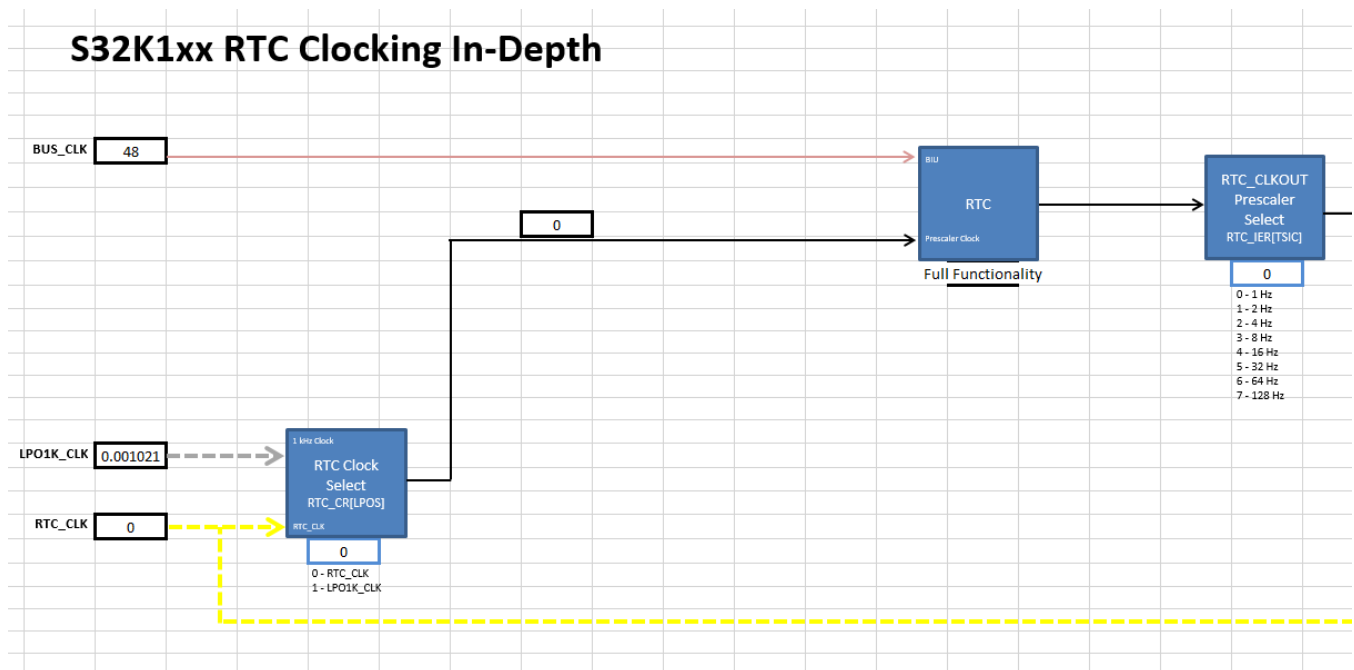

Figure 15. S32K RTC clocking

2.9 Summary

Almost all blocks populating this clock calculator represent real register fields in silicon. The *Summary* tab collates all the information from the rest of the clock calculator into a list of register values, a screenshot of which is shown in the following figure. The values in the register summary are interactive, updating automatically when the associated block is changed. Registers listed within *Summary* are only the ones whose values are affected by clock configuration, not every single register available in the SoC.

S32K1xx Summary

Register Summary

Register	Value
SCG_FIRCCFG	0x00000000
SCG_FIRCCSR	0b00000X11X0000000000000XX0000X001
SCG_FIRCDIV	0x00000000
SCG_SIRCCFG	0x00000001
SCG_SIRCCSR	0x0XX00005
SCG_SIRCDIV	0x00000000
SCG_SOSCCFG	0b00000000000000000000000000001X000
SCG_SOSCCSR	0b00000X00X00000XX00000000000X0000
SCG_SOSCDIV	0x00000000
SCG_SPLLCFG	0x00000000
SCG_SPLLDIV	0x00000000
SCG_SPLLCSR	0b00000XXXX00000XX0000000000000000
SMC_PMPROT	0x00000000
SMC_PMCTRL	0b0000000000000000000000000000X000
SMC_STOPCTRL	0x00000003
PMC_LPOTRIM	0x1C
PMC_REGSC	0b0X000X00
SCG_RCCR	0x03000001
SCG_VCCR	0x00000000
SCG_HCCR	0x00000000
SCG_CLKOUTCNFG	0x03000000
SIM_LPOCLKS	0x00000003
SIM_CHIPCTL	0b0000000000XXXXXX00XX00000000XXXX

Figure 16. Register summary table

The register values are displayed in either hexadecimal or binary format, where an “0x” header represents hexadecimal and “0b” denotes binary. A capital “X” represents a “don’t care” bit/half-byte. These bits do affect the clock frequency so users can set these values to the values that suit their purposes. Users can best utilize *Summary* by setting the configuration they want in the clock calculator and then copying the resulting register value into code. For example, taking from the figure above, the register SCG_SIRCCSR, should be set to 0x0XX00001. Assuming the “X” are “0,” the resulting S32DS C code would be "SCG->SIRCCSR = 0x00000001;".

Summary also includes an overview of the clock domain frequencies. Since this tool consists of multiple interdependent spreadsheets, it may be cumbersome for users to weave through them all to find a clock domain. This table provides a place where all of them can be found. The table is organized by module, followed by the clock type (i.e. BIU clock, peripheral clock, protocol clock, etc.), and finally the frequency, as currently configured. Below is a screenshot.

Module	Clock Domain	Frequency (MHz)
System	FIRC	48
	SIRC	8
	SOSC	8
	LPO128K_CLK	0.128
	LPO32K_CLK	0.032
	LPO1K_CLK	0.001
	SPLL_CLK	96
	CORE_CLK	48
	SYS_CLK	48
	BUS_CLK	48
	FLASH_CLK	24
	SPLLDIV1_CLK	0
	SPLLDIV2_CLK	0
	FIRCDIV1_CLK	0
	FIRCDIV2_CLK	24
	SIRCDIV1_CLK	0
	SIRCDIV2_CLK	0
	SOSCDIV1_CLK	0
	SOSCDIV2_CLK	0
	CLKOUT	0
LPO_CLK	0.128	
RTC_CLKOUT	0	
LPSPI0:2	BIU	48
	Peripheral Clock	24

Figure 17. Clock summary table

This tool also supports a degree of code generation. *Summary* provides two sample clock initialization functions, *SysClk_Init* for configuring oscillators and PLLs and *InitPeriClkGen* for providing sources/dividers to auxiliary clocks. The dynamic C code in these functions depend on tool settings just like the register summary. These functions can be copy-pasted to a source file via Ctrl+C/Ctrl+V or by clicking on the associated *Copy Code* button if macros are enabled. The following figure shows *SysClk_Init* and its *Copy Code* button.

Copy Code
Sai

```

//Enable oscillators, PLL, and system clock (48 MHz).
void SysClk_Init(void)
{
    uint32_t temp = 0; //Temporary variable for read-modify-write sequences

    //Configure the FIRC
    SCG->FIRCCFG = 0x00000000; //Trim FIRC to 48 MHz
    SCG->FIRCCSR |= SCG_FIRCCSR_FIRCEN(0x1); //Turn on the FIRC

    //Configure the SIRC
    SCG->SIRCCFG = 0x00000001; //Select 8 MHz range
    SCG->SIRCCSR |= SCG_SIRCCSR_SIRCLPEN(1); //SIRC enabled in VLPS/VLPR mode
    SCG->SIRCCSR &= ~SCG_SIRCCSR_SIRCSTEN(1); //SIRC disabled in STOP mode
    SCG->SIRCCSR |= SCG_SIRCCSR_SIRCEN(1); //EnableSIRC (8 MHz)
    //Configure SIRC low power options
    PMC->REGSC &= ~PMC_REGSC_BIASEN(1); //Biasing disabled
    PMC->REGSC &= ~PMC_REGSC_CLKBIASDIS(1); //Clock current/voltage disabled in VLPS

    //Configure SOSC
    SCG->SOSCCFG &= ~SCG_SOSCCFG_EREFS(1); //Select EXTAL as source of SOSC_CLK so clock sig

    //Configure SPLL
    SCG->SPLLCSR &= ~SCG_SPLLCSR_SPLEN_MASK; //Disable SPLL while being configured
    SCG->SPLLCFG = SCG_SPLLCFG_MULT(0)|SCG_SPLLCFG_PREDIV(0); //Configure the dividers. Pre
    SCG->SPLLCSR &= ~SCG_SPLLCSR_SPLEN(1); //Disable SPLL (0 MHz)

```

Figure 18. Sample initialization code

2.10 Limits

Limits is the reference tab for all the color-coding rules. The values in its tables are based on the S32K datasheet and reference manual and so should not be modified by the user. The following figure is a screenshot of the *Limits* tab.

	A	B
1		
2	Do not change these numbers	
3	SPLL Input (min)	8
4	SPLL Input (max)	40
5	SPLL_VCO_CLK (min)	180
6	SPLL_VCO_CLK (max)	320
7	SPLL_CLK (min)	90
8	SPLL_CLK (max)	160
9		
10		
11		
12		
13		
14	Clock Name	Max (MHz) - Run
15	CORE_CLK	80
16	SYS_CLK	80
17	BUS_CLK	48
18	FLASH_CLK	26.67
19	ADC	50
20		
21	Clock Name	Max (MHz) - HSRUN
22	CORE_CLK	112
23	SYS_CLK	112
24	BUS_CLK	56
25	FLASH_CLK	28
26	ADC	50
27		
28	Clock Name	Max (MHz) - VLPR
29	CORE_CLK	4
30	SYS_CLK	4
31	BUS_CLK	4
32	FLASH_CLK	1
33	ADC	4
34	Flash Memory	1
35		
36	Clock Name	Max (MHz) - STOP1
37	CORE_CLK	0

Figure 19. S32K frequency limits

3 Clock tool example use case: Configure LPSPi to SPLL BUS_CLK at 48 MHz and peripheral clock at 24MHz FIRC in RUN mode on S32K14x

The following sections will present an example application of the S32K clock calculator. This application note's example will configure the LPSPi bus interface clock to SPLL at 40 MHz and the LPSPi peripheral clock to FIRC at 24 MHz. It will not only show the correct configurations but also how the tool responds if improper configurations are attempted.

When configuring clocks for a module, start by looking at the module block. For this example, find *LPSPi0:2* within *Module Domains*.

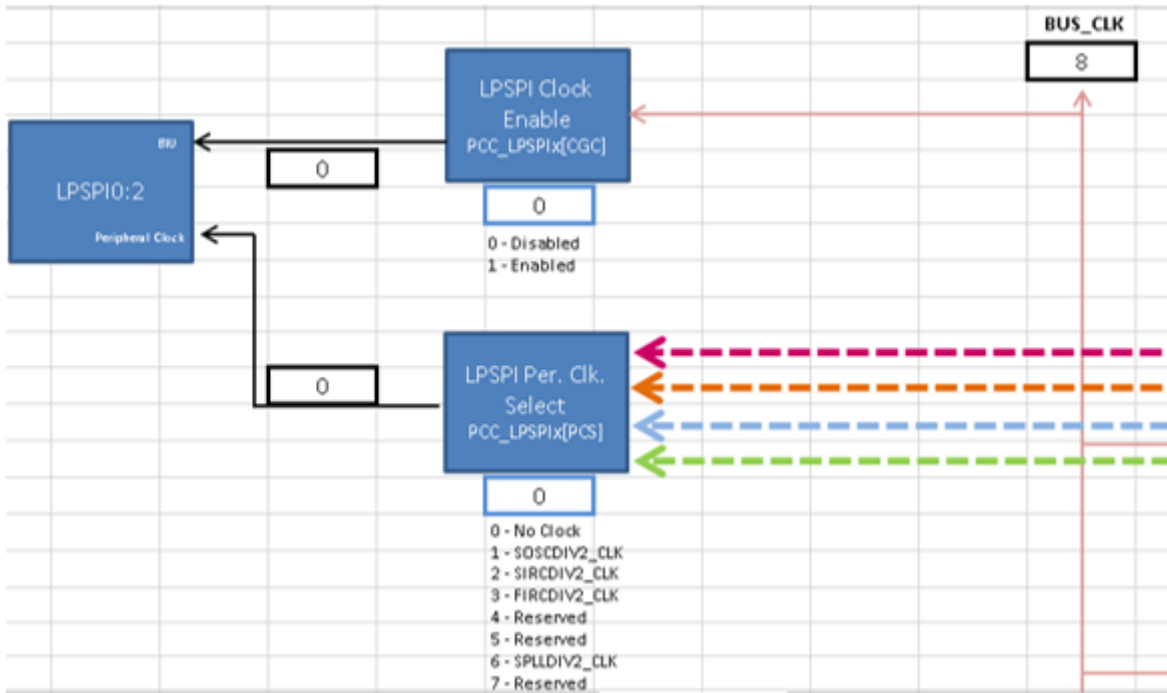

Figure 20. LPSPI clocks

The module diagram shows that *BUS_CLK* drives the bus interface and either *SOSCDIV2_CLK*, *SIRCDIV2_CLK*, *FIRCDIV2_CLK*, or *SPLLDIV2_CLK* drives the LPSPI peripheral engine clock. The LPSPI bus interface clock, *BUS_CLK*, is currently 8 MHz; the LPSPI peripheral clock is 0 MHz, because the block *LPSPI Per. Clk. Select* contains the value 0, meaning no clock is selected. Configuring the clock calculator can be in any order, this example will start with *BUS_CLK*.

3.1 Set the device

First, make sure the correct S32K flavor is chosen. This example sets out to configure the S32K14x, so go to the *Device Select* tab and change the device to *S32K14x*.

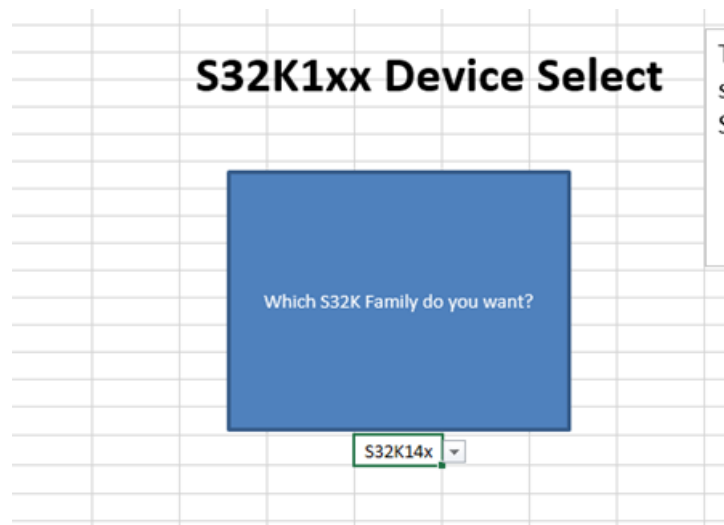

Figure 21. S32K14x selected

3.2 Set the power mode

Next make sure that the system is in Run mode. Go to the *Power Mode Control* tab and set the *S32K Power Mode* block to Run, as in the next figure.

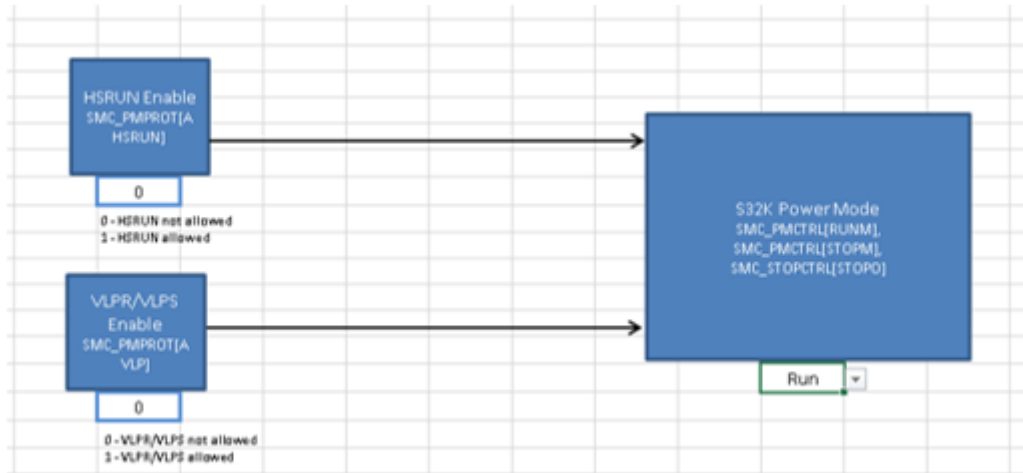

Figure 22. S32K in run mode

3.3 Configure BUS_CLK

Return to the *Module Domains* tab and click on *BUS_CLK*; it will take you to the *BUS_CLK* of *Tree*, shown below.

Clock tool example use case: Configure LPSP1 to SPL1 BUS_CLK at 48 MHz and peripheral clock at 24MHz FIRC in RUN mode on S32K14x

oscillator XTAL or a signal driven into a pin, EXTAL. XTAL is application-dependent and can be any value between 4 MHz and 8 MHz or 8 MHz and 40 MHz, depending on XTAL configuration. EXTAL must be under 50 MHz. Set the SOSC Range block to 3 to select the 8-40 MHz range, shown in the next figure. The 4-8/8-40 MHz SOSC block can now take any value between 8 and 40 MHz.

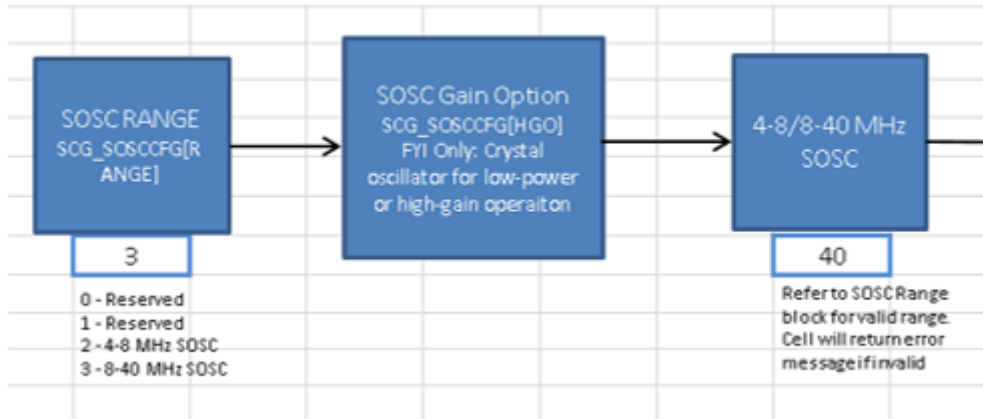

Figure 25. SOSC set to high range

This tool has a safeguard to prevent invalid values from being entered. The figure below shows an attempt to enter 7 MHz to the SOSC frequency cell. A dialog box appears notifying the user that the value is not accepted when he/she tries to click away from the cell.

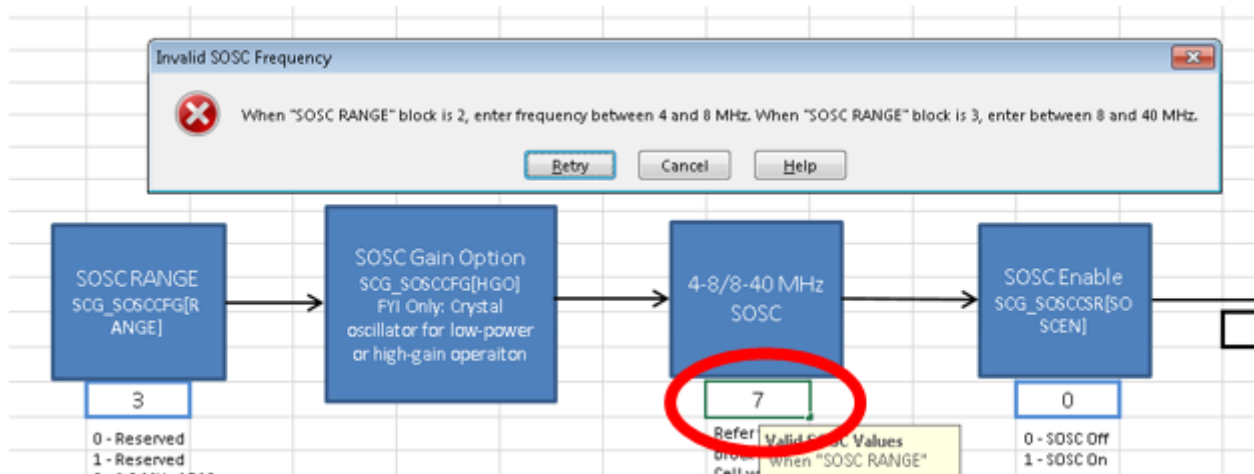

Figure 26. Invalid frequency input

Set the SOSC frequency to 8 MHz. Trace forward from the 4-8/8-40 MHz SOSC block to SOSC Enable. Set SOSC Enable to 1 to enable the 8 MHz SOSC to propagate downstream, shown below.

Clock tool example use case: Configure LPSP1 to SPLL BUS_CLK at 48 MHz and peripheral clock at 24MHz FIRC in RUN mode on S32K14x

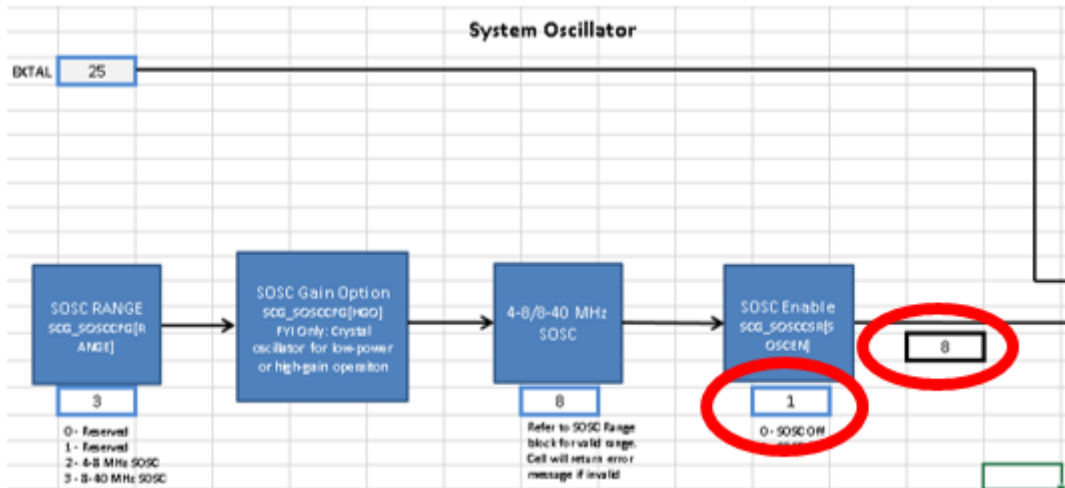

Figure 27. SOSC Turned On

Next, configure *Ext. Ref. Select* to 1 to select XTAL over EXTAL. *SOSC_CLK* will be sourced from the system oscillator at 8 MHz rather than the EXTAL pin. See below.

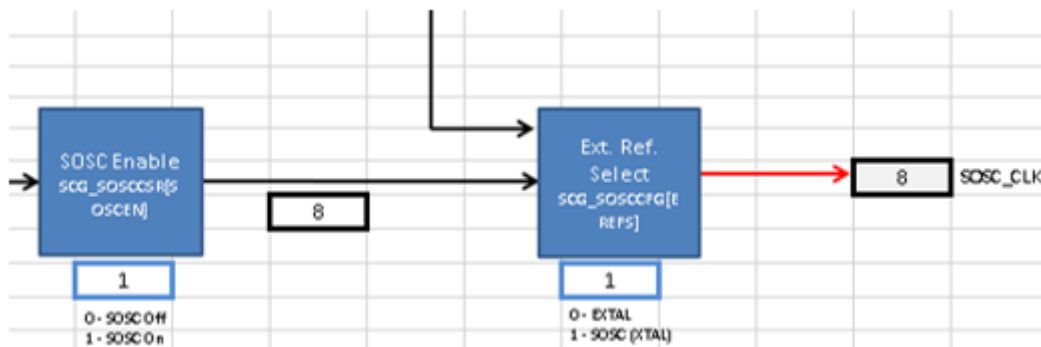

Figure 28. SOSC_CLK configured to follow external oscillator at 40 MHz

3.3.2 Configure SPLL

Now that *SOSC_CLK* is set to 8 MHz, go back to *Tree* and follow *SOSC_CLK* to the *SPLL* block, as seen in the next figure.

Clock tool example use case: Configure LPSPi to SPLL BUS_CLK at 48 MHz and peripheral clock at 24MHz FIRC in RUN mode on S32K14x

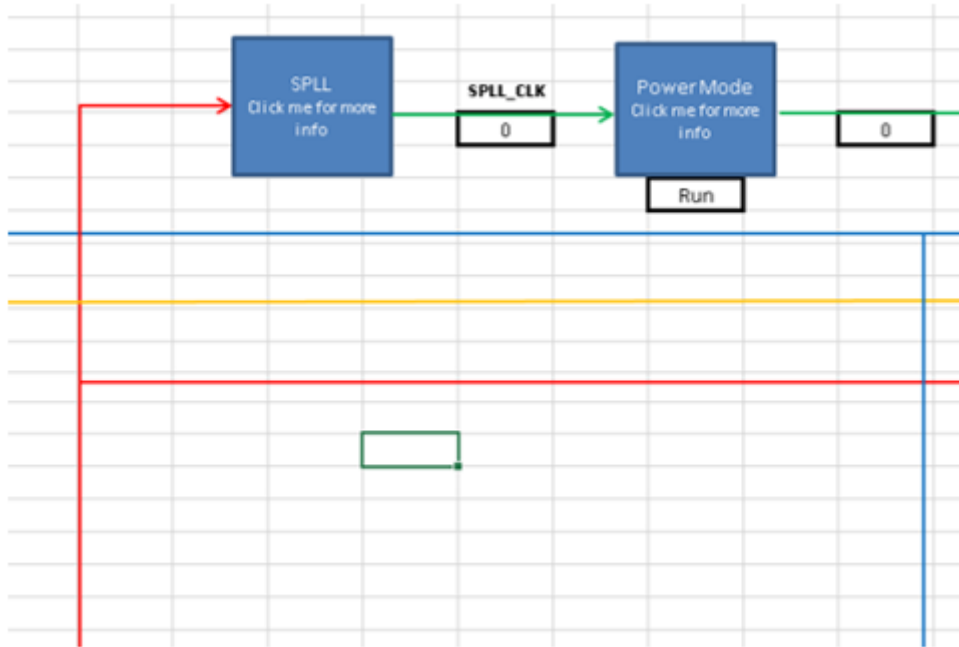

Figure 29. SPLL

Click on the *SPLL* block to forward automatically to the *SPLL* tab. This is the tab that sets up the *SPLL_CLK* frequency. The *Input Clock* block of the figure below shows that SPLL detects the 8 MHz *SOSC_CLK* as its source frequency.

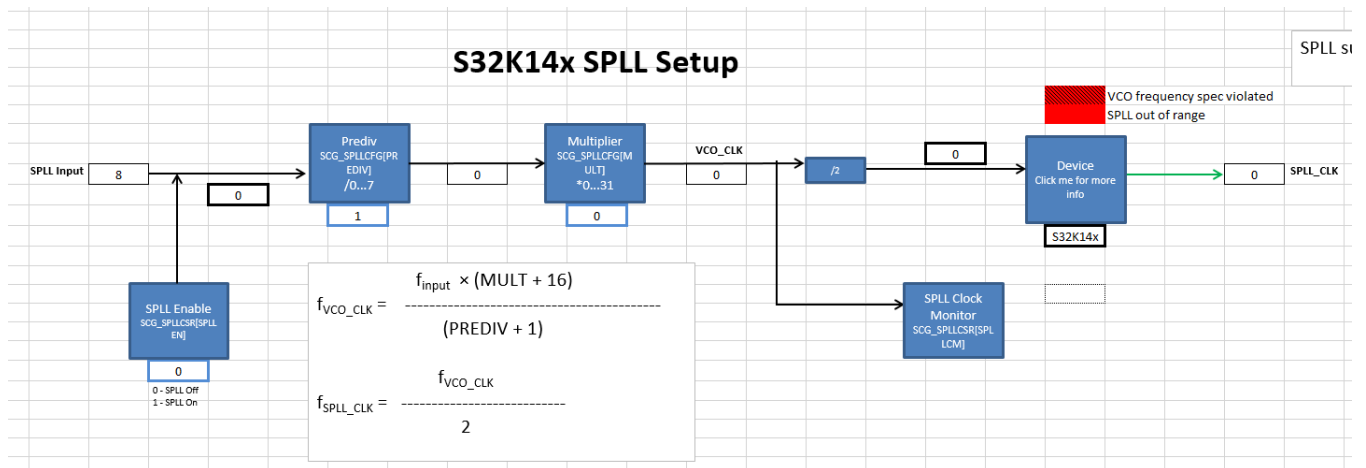

Figure 30. SPLL Calculator

Configure the dividers to achieve 96 MHz; this frequency will be divided to 48 MHz later. The correct configuration can be achieved by trial and error, but the S32K clock calculator provides a lookup table in the *spll_clk* tab, shown below.

Clock tool example use case: Configure LPSP1 to SPLL BUS_CLK at 48 MHz and peripheral clock at 24MHz FIRC in RUN mode on S32K14x

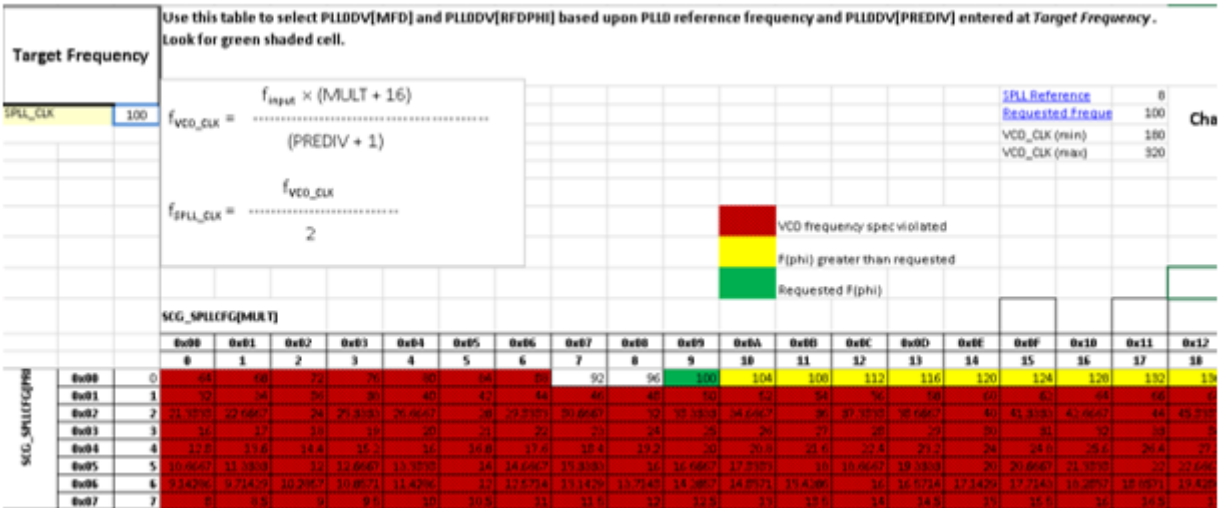

Figure 31. spll_clk reference table

The SPLL reference field is the frequency of the SPLL input, in this case the 8 MHz SOSC. Set the target frequency. This example will target 96 MHz. The values and shading in the lookup table will automatically change to fit these new settings. In the figure below, the table has changed and circled is the modified field.

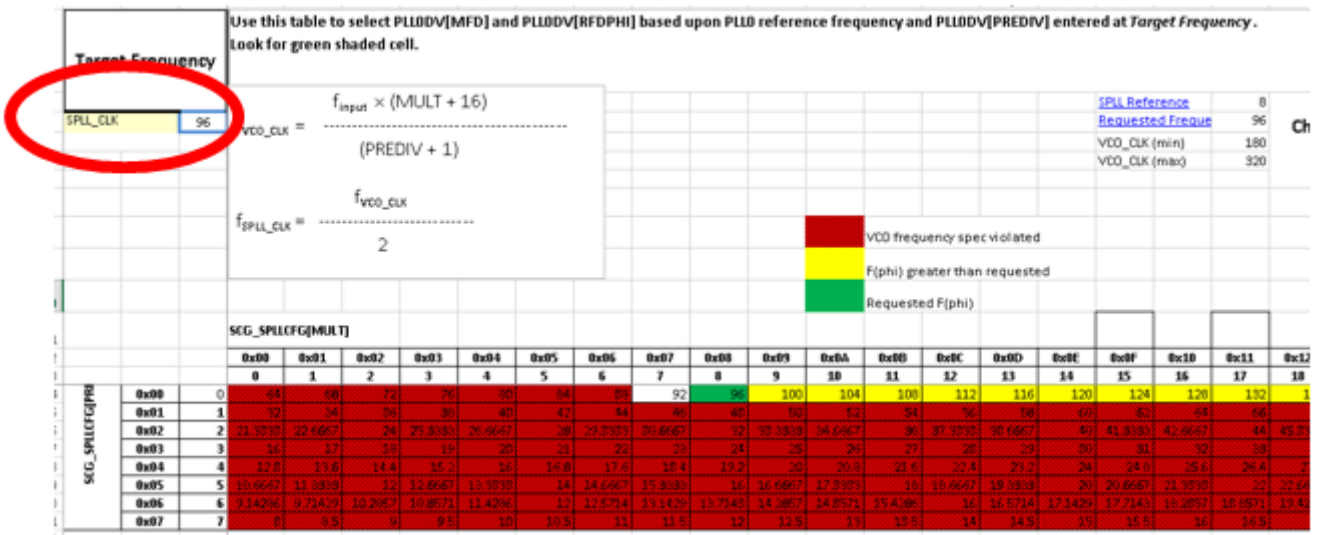

Figure 32. spll_clk table with new settings

The cell shaded green means there is a divider combination that can achieve exactly 96 MHz given an input frequency of 8 MHz. In this case, a MFD of 8 and a PREDIV value of 0 will do the job. However, it is worth noting what happens if the output SPLL frequency is out of range.

In the following figure, the SPLL has been configured so that the output frequency is 188 MHz. This obviously exceeds the maximum hardware spec of 160 MHz. The associated voltage controlled oscillator (VCO) frequency, which can be back-calculated from SPLL_CLK also exceeds the maximum VCO spec of 320 MHz. Therefore, the output is crosshatched and shaded red.

Clock tool example use case: Configure LPSPI to SPLL BUS_CLK at 48 MHz and peripheral clock at 24MHz FIRC in RUN mode on S32K14x

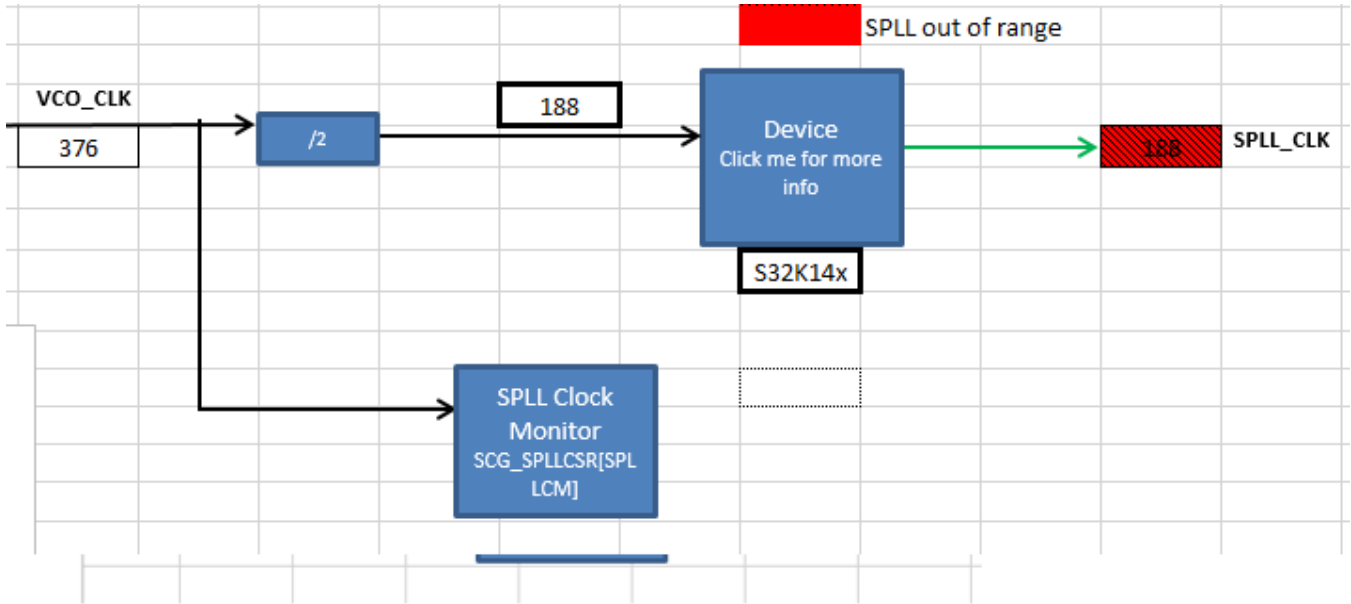

Figure 33. When SPLL_CLK exceeds VCO and PLL spec

Now let's configure the SPLL correctly. Turn on the SPLL in the SPLL tab by setting the SPLL Enable block to 1, and then set Prediv to 0 and Multiplier to 8. As shown in the next figure, the output SPLL_CLK is 96 MHz and the cell remains unshaded, meaning the configuration fits within spec.

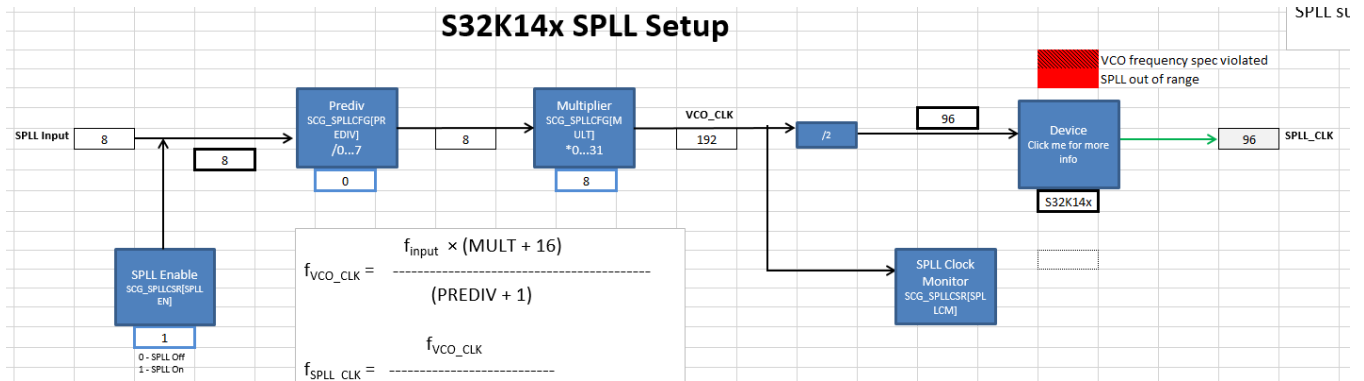

Figure 34. SPLL_CLK configured to 96 MHz

Go back to Tree to observe that the SPLL_CLK frequency is now 96 MHz.

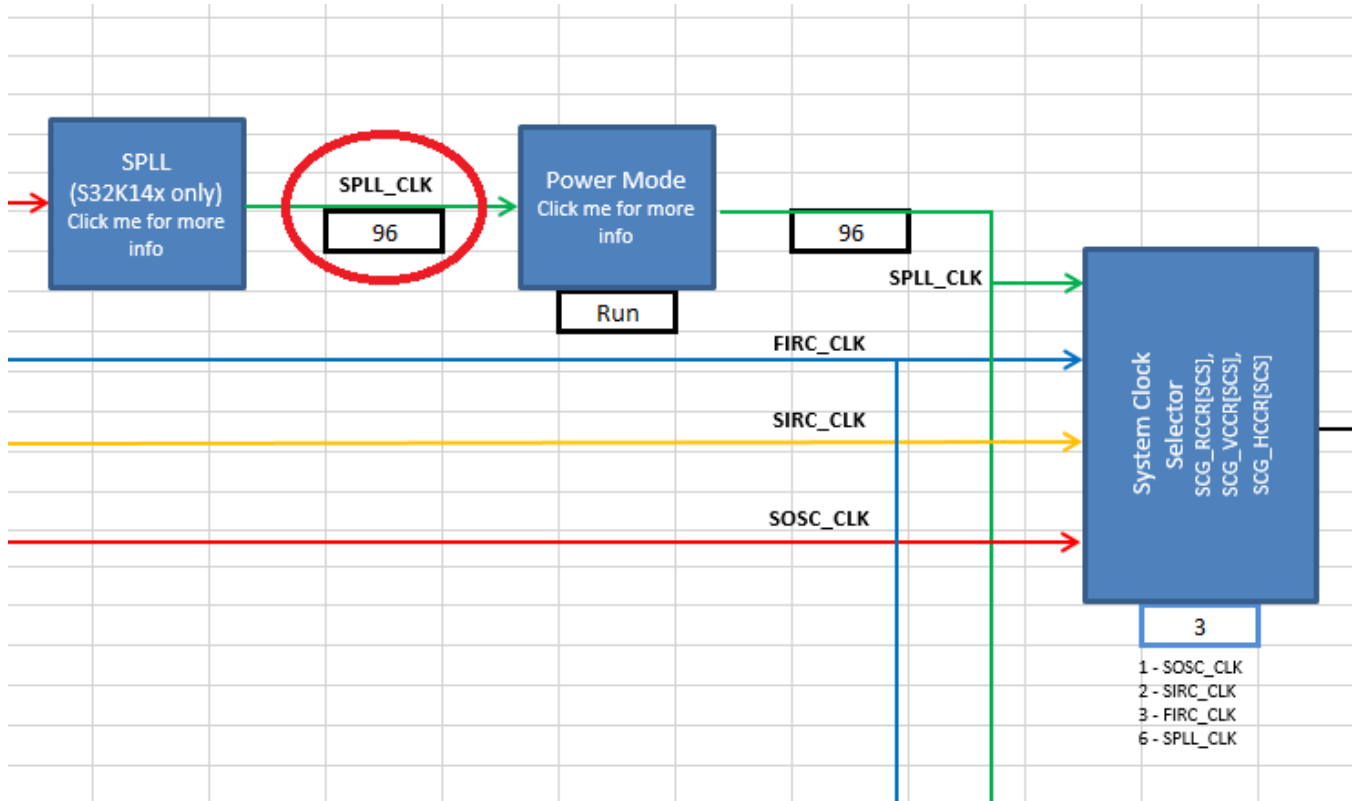

Figure 35. SPLL_CLK propagated to Tree

3.3.3 Finish Setting BUS_CLK

BUS_CLK is one of the system clocks. So, follow the *SPLL_CLK* signal down to *System Clock Selector*. *SIRC_CLK* is the current source of the system clocks. Change the value of *System Clock Selector* to 6 for the system clocks to follow *SPLL_CLK*, shown below.

Clock tool example use case: Configure LPSPi to SPLL BUS_CLK at 48 MHz and peripheral clock at 24MHz FIRC in RUN mode on S32K14x

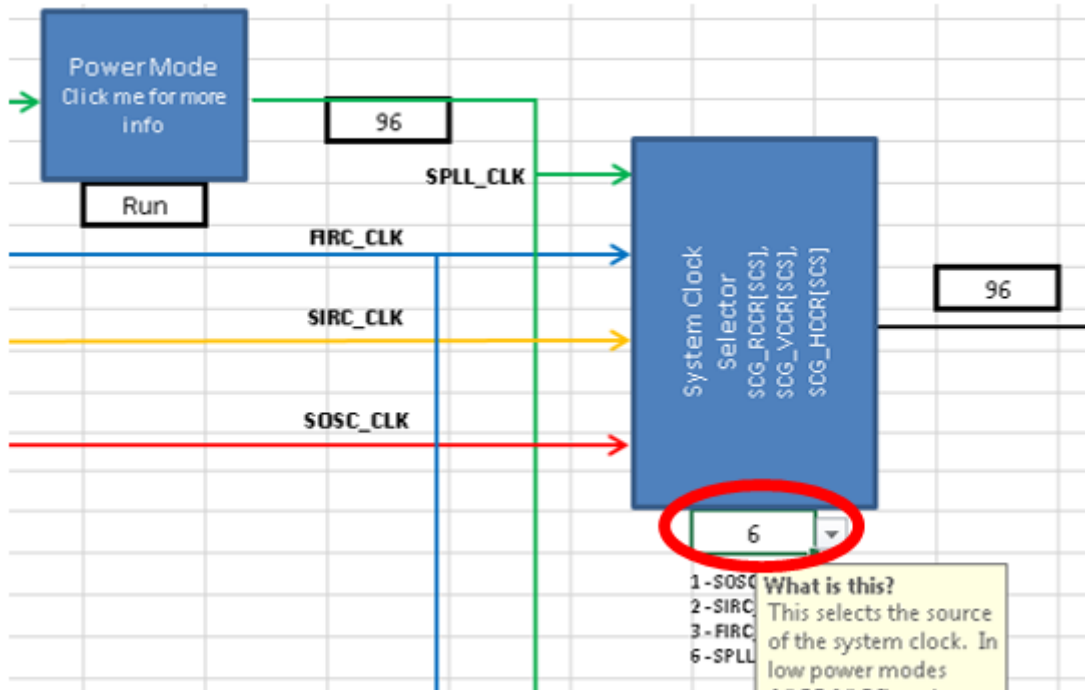

Figure 36. System Clock changed to FMPLL

After this, follow the system clock output to *DIVCORE*. The max frequency of *CORE_CLK* and *SYS_CLK* is 48 MHz in Run mode, so set *DIVCORE* from 0 to 1. This will divide the 96 Mhz signal by 2, thereby setting *CORE_CLK* and *SYS_CLK* to 48 MHz as well as the input to the *DIVBUS* block, whose output is *BUS_CLK*. See the figure below.

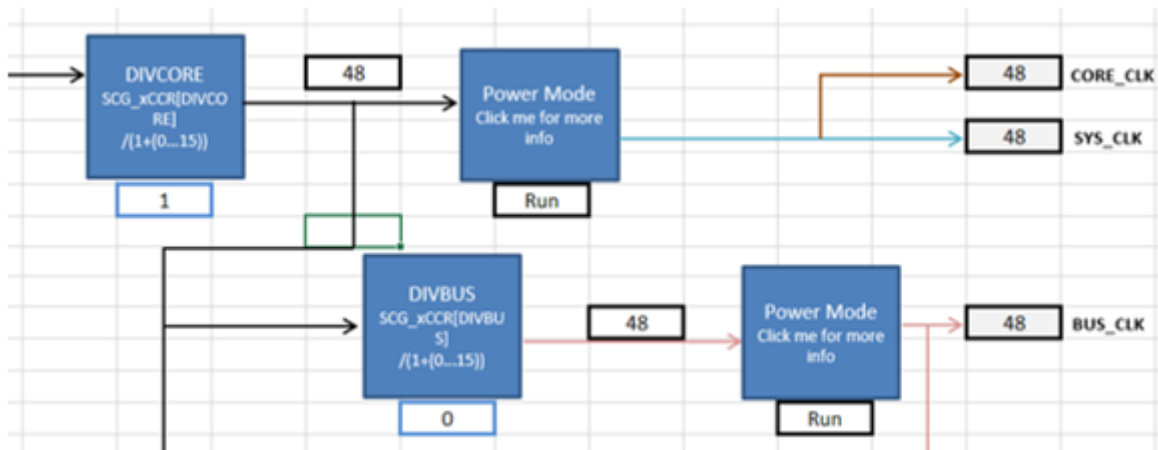

Figure 37. DIVCORE at 2

The user input for these fields is not the desired divider but the bitfield value that one would have to enter to achieve the desired divider. That is why the *DIVCORE* block description states “/(1+(0...15))” rather than simply “/1...16”. The user provides a value between 0 and 15, to which the hardware automatically adds 1 to calculate a divider that is between 1 and 16.

If, for example, *DIVCORE* is left at 0, which corresponds to a divider of 1, *CORE_CLK* and *SYS_CLK* would be 96 MHz, which would exceed their maximum allowable frequency of 48 MHz. The tool will highlight their cells red to signify that such a frequency is not allowed, shown below.

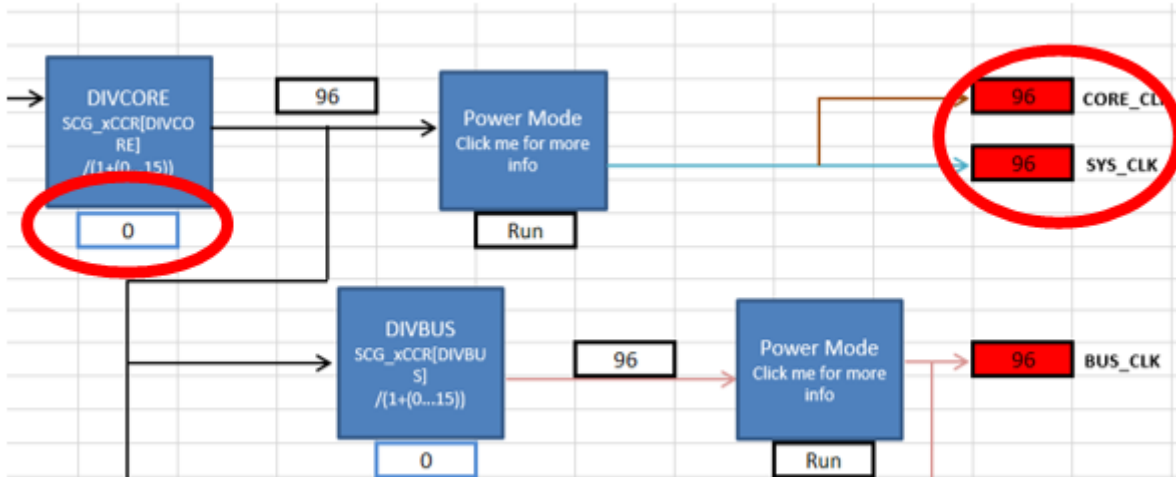

Figure 38. System clocks when frequency exceeds spec

Set *DIVCORE* back to 1 and leave *DIVBUS* at 0 in order to keep *BUS_CLK* at 48 MHz. *BUS_CLK* has now been configured to 48 MHz SPLLL, as seen in the figure below.

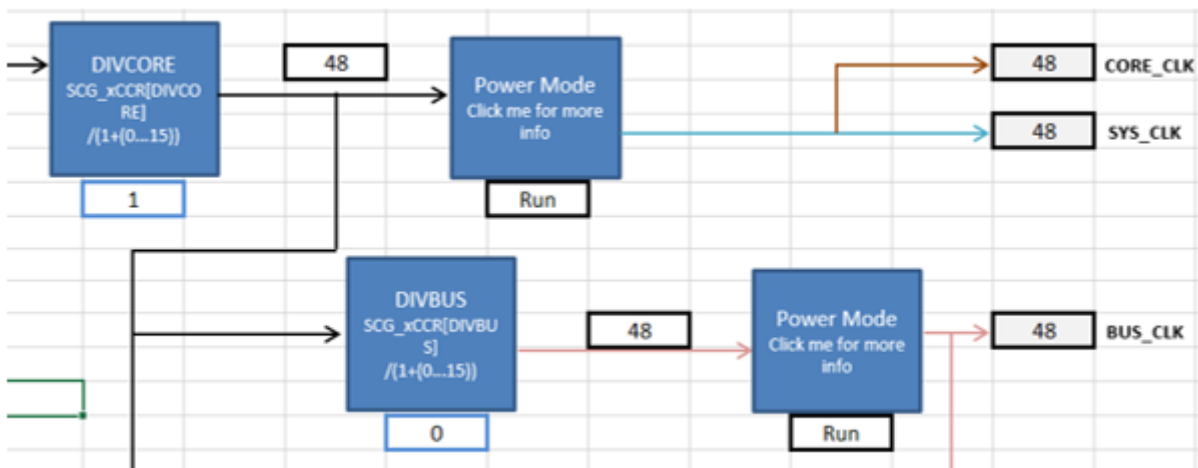

Figure 39. BUS_CLK correctly configured

3.4 Configure LPSPI Peripheral Clock, FIRCDIV2_CLK

LPSPI follows *BUS_CLK* for its bus interface clock, but the peripheral clock can be *SOSCDIV2_CLK*, *SIRCDIV2_CLK*, *FIRCDIV2_CLK*, or *SPLLDIV2_CLK*. This example will set the peripheral clock to *FIRCDIV2_CLK* at 24 MHz. Go to the 48 MHz *FIRC* block in *Tree*. S32K's *FIRC* can only be trimmed to 48 MHz, so leave the 48 MHz *FIRC* block value at 0 and set *FIRC Enable* to 1 to make the signal propagate, as shown below.

Clock tool example use case: Configure LPSPi to SPLl BUS_CLK at 48 MHz and peripheral clock at 24MHz FIRC in RUN mode on S32K14x

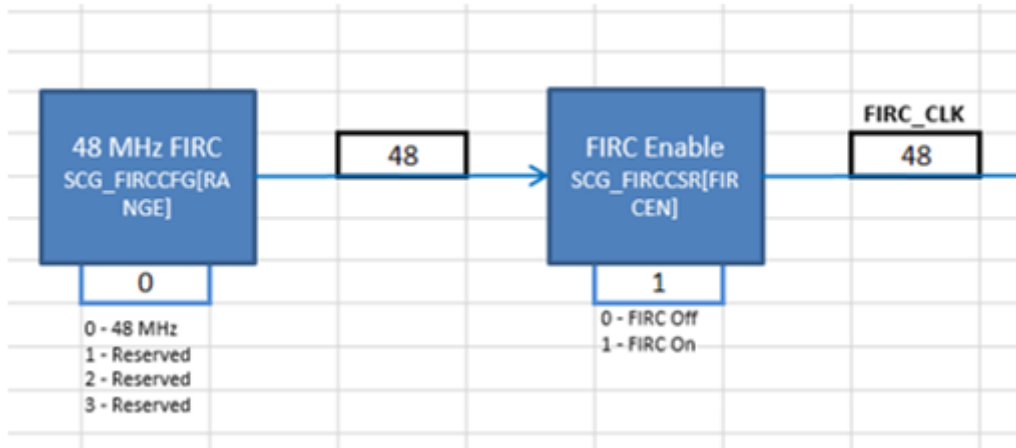

Figure 40. FIRC at 48 MHz

Trace the FIRC clock signal to the *FIRCDIV2* block in *Tree* and set the block to 2. This enables *FIRCDIV2_CLK* and divides the 60 MHz FIRC signal by 2, thus achieving an *FIRCDIV2_CLK* domain of 30 MHz. See the following figure.

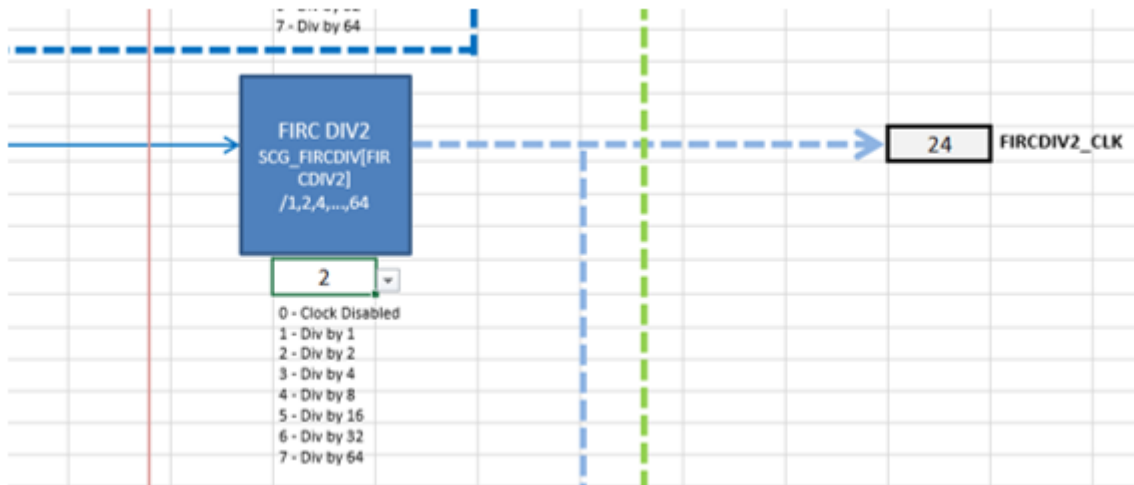

Figure 41. FIRCDIV2_CLK set to 30 MHz

3.5 Configure LPSPi clocks

Go back to the *Module Domains* tab. Set the *LPSPi Clock Enable* block to 1 to enable the *BUS_CLK* signal. The LPSPi bus interface clock is now the 48 MHz *BUS_CLK*. Configure the LPSPi peripheral clock to *FIRCDIV2_CLK*, setting the value of the *LPSPi Per. Clk. Select* block to 3. The LPSPi configuration will look like the following figure.

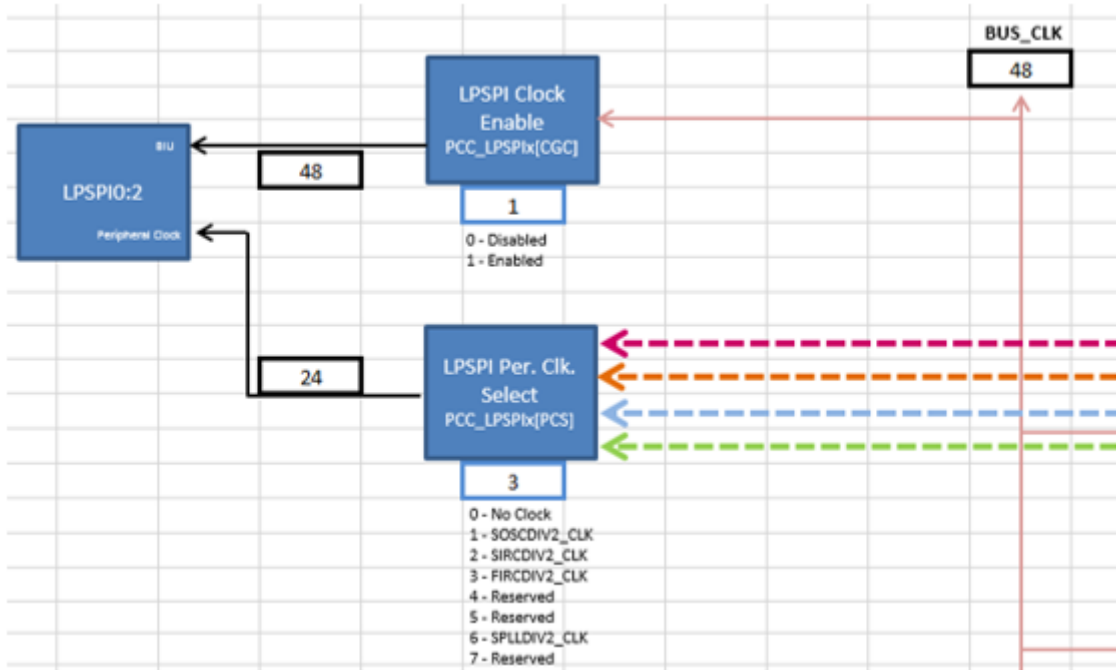

Figure 42. LPSPi final configuration

3.6 Observe the registers

The final register summary table, as displayed in *Summary*, is shown in the figure below. Note that most of these registers would not have to be written in code to achieve the setup that this example just configured. For example, the register PCC_FlexIO would not have to be included, since the FlexIO module was untouched. Registers that *would* have to be written would be ones like SCG_FIRC DIV and PCC_LPSPix (the “x” means the LPSPi instance of your choice).

Register	Value
SCG_FIRCCFG	0x00000000
SCG_FIRCCSR	0b00000X11X000000000000000XX0000X001
SCG_FIRCDIV	0x00000200
SCG_SIRCCFG	0x00000001
SCG_SIRCCSR	0x0X00001
SCG_SIRCDIV	0x00000000
SCG_SOSC CFG	0b000000000000000000000000000011X100
SCG_SOSCCSR	0b00000X00X00000XX0000000000000X0001
SCG_SOSCDIV	0x00000000
SCG_SPLLCFG	0x00080000
SCG_SPLLDIV	0x00000000
SCG_SPLLC SR	0b00000XXX00000XX0000000000000001
SMC_PMPROT	0x000000A0
SMC_PMCTRL	0b0000000000000000000000000000X000
SMC_STOPCTRL	0x00000003
PMC_LPOTRIM	0x00
PMC_REGSC	0b0X000X00
SCG_RCCR	0x06010001
SCG_VCCR	0x00000000
SCG_HCCR	0x00000000
SCG_CLKOUTCNFG	0x03000000
SIM_LPOCLKS	0x00000003
SIM_CHIPCTL	0b0000000000XXXXXX00XX00011001XXXX
PCC_LPSPiX	0xC3000000
PCC_LPIT	0x80000000
PCC_FlexIO	0x80000000
FLEXIO_CTRL	0bXX0000000000000000000000000000XX
PCC_LPI2Cx	0x80000000
PCC_LPUARTx	0x80000000
PCC_EWM	0x80000000

Figure 43. Register summary after configuration

3.7 Copy the code

SysClk_Init and *InitPeriClkGen* provides dynamic clock generation C code. The code will configure the clocks to the settings as configured in this clock calculator. It can be copied and pasted to a source file. The following figure shows *SysClk_Init* as configured by this example. The solid-bordered highlight around the function means that the code has been copied with the *Copy Code* button; a regular Ctrl+C causes a dashed-bordered highlight. In both cases, the code can be pasted into a source with a regular Ctrl+V.

Clock tool example use case: Configure LPSP1 to SPL1 BUS_CLK at 48 MHz and peripheral clock at 24MHz FIRC in RUN mode on S32K14x

Copy Code
Sample Initialization Code

```

//Enable oscillators, PLL, and system clock (48 MHz).
void SysClk_Init(void)
{
    uint32_t temp = 0; //Temporary variable for read-modify-write sequences

    //Configure the FIRC
    SCG->FIRCCFG = 0x00000000; //Trim FIRC to 48 MHz
    SCG->FIRCCSR |= SCG_FIRCCSR_FIRCEN(0x1); //Turn on the FIRC

    //Configure the SIRC
    SCG->SIRCCFG = 0x00000000; //Select 8 MHz range
    SCG->SIRCCSR |= SCG_SIRCCSR_SIRCLPEN(1); //SIRC enabled in VLPS/VLPR mode
    SCG->SIRCCSR &= ~SCG_SIRCCSR_SIRCSLEN(1); //SIRC disabled in STOP mode
    SCG->SIRCCSR |= SCG_SIRCCSR_SIRCEN(1); //Enable SIRC (8 MHz)
    //Configure SIRC low power options
    PMC->REGSC &= ~PMC_REGSC_BIASEN(1); //Biasing disabled
    PMC->REGSC &= ~PMC_REGSC_CLKBIASDIS(1); //Clock current/voltage disabled in VLPS

    //Configure SOSC
    SCG->SOSCCFG |= SCG_SOSCCFG_EREFS(1); //Select external oscillator hooked to XTAL and EXTAL pins as source of
    //Select the range of the external oscillator
    temp = SCG->SOSCCFG; //read-modify-write for multi-bit RANGE field
    temp &= ~SCG_SOSCCFG_RANGE_MASK; //Clear field
    temp |= SCG_SOSCCFG_RANGE(1); //8-40 SOSC range
    SCG->SOSCCFG = temp; //Write new value to register
    SCG->SOSCCSR |= SCG_SOSCCSR_SOSCEN(1); //Enable SOSC (8 MHz)

    //Configure SPL1
    SCG->SPL1CSR &= ~SCG_SPL1CSR_SPLLEN_MASK; //Disable SPL1 while being configured
    SCG->SPL1CFG = SCG_SPL1CFG_MULT(8)|SCG_SPL1CFG_PREDIV(0); //Configure the dividers. Prediv = 0 Mult = 8.
    SCG->SPL1CSR |= SCG_SPL1CSR_SPLLEN(1); //Enable SPL1 (96 MHz)

    //Configure SCG_CLKOUT
    SCG->CLKOUTCNFG = 0x03000000; //Select FIRC_CLK as source of SCG_CLKOUT

    //Configure the low power oscillator
    PMC->LPTRIM = 0x00; //Configure the LPO trim value. LPO is 128 kHz.
    PMC->REGSC &= ~PMC_REGSC_LPODIS(1); //Enable the LPO
    //Configure the LPO_CLK source
    temp = SIM->LPOCLKS; //Read-modify-write
    temp &= ~(SIM_LPOCLKS_LPOCLKSEL_MASK|SIM_LPOCLKS_LPO32KCLKEN_MASK|SIM_LPOCLKS_LPO1KCLKEN); //
    temp |= SIM_LPOCLKS_LPO32KCLKEN(1); //Enable LPO32K_CLK
    temp |= SIM_LPOCLKS_LPO1KCLKEN(1); //Enable LPO1K_CLK
    temp |= 0; //Select LPO128K_CLK as source of LPO_CLK
    SIM->LPOCLKS = temp; //Write to register

    //Configure the system clock source and dividers, depending on power mode
    SCG->RCCR = SCG_RCCR_SCS(6)|SCG_RCCR_DIVCORE(1)|SCG_RCCR_DIVBUS(0)|SCG_RCCR_DIVSLOW(1);

    //Configure the S32K power modes
    SMC->PMPROT = 0x00000000; //HSRUN disabled and VLPR/VLPS disabled.
    //Switch to Run.
    SMC->PMCTRL = SMC_PMCTRL_RUNM(0); //Switch to normal Run mode
}
    
```

Copy Code

Figure 44. SysClk_Init after example

So, to summarize, this example has achieved its goal: a bus interface clock whose signal is driven by the *BUS_CLK* at 48 MHz. *BUS_CLK* comes from an 8 MHz SOSC driving an SPL1 that produces an output of 96 MHz, and from there the SPL1 driving *BUS_CLK* at 48 MHz. And finally a peripheral clock driven by a 24 MHz *FIRCDIV2_CLK* whose source is divided from a 48 MHz FIRC.

4 Conclusion

This application note gives an overview of the S32K interactive clock calculator. It seeks to aid clock configuration in the form of a graphical tool so that a user can more easily visualize the device's clock signals' propagation. There are similar clock calculators for other NXP products, including the MPC574xP and MPC574xG. Visit the [NXP website](#) to find more of these tools.

5 Revision history

Revision Number	Date	Substantive changes
1	05/2017	<ul style="list-style-type: none"> In Summary on page 11 added the text "Summary aslo includes.....is a screenshot" and added Figure 17 on page 13. Updated the S32K14x_Clock_Calculator sheet, please see the attachment.
2	08/2017	<ul style="list-style-type: none"> In Introduction added the texts "The clock calculator.....Enable all macros" and "Attached to this.....the attachment". Added figure Enabling macros and Finding the tool. In Tree on page 4 added the text "This tab also.....of the buttons" and added figure Buttons. Changed the section name from "RTC clocking" to "Detailed module diagrams (RTC, SAI, QSPI, ENET, FlexCAN)" and updated the section. In Summary added the text "This tool also..... Copy code button" and added figure Sample initialization code Added section Copy the Code. Added the updated S32K14x_Clock_Calculator_Rev3
3	11/2017	Updated the associated S32K14x_Clock_Calculator file.
4	01/2018	Updated the associated S32K14x_Clock_Calculator file.

Table continues on the next page...

Table continued from the previous page...

Revision Number	Date	Substantive changes
5	08/2018	<ul style="list-style-type: none"> • Added information for S32K11x family. • Updated Introduction on page 1 • Added Device select on page 6 • Added Set the device on page 16 • Changed the name to Clock tool example use case: Configure LPSPi to SPLL BUS_CLK at 48 MHz and peripheral clock at 24MHz FIRC in RUN mode on S32K14x on page 15 • Updated SPLL Calculator, When SPLL_CLK exceeds VCO and PLL spec, SPLL_CLK propagated to Tree and SPLL_CLK configured to 96 MHz. • Updated Register summary table. • Updated S32K RTC clocking. • Updated SPLL control. • Updated S32K power mode control. • Updated Clock calculator tree and Buttons. • Updated S32K1xx clock calculator setup.
6	09/2018	Updated the associated S32K14x_Clock_Calculator file.

How To Reach Us

Home Page:

nxp.com

Web Support:

nxp.com/support

Information in this document is provided solely to enable system and software implementers to use NXP products. There are no express or implied copyright licenses granted hereunder to design or fabricate any integrated circuits based on the information in this document. NXP reserves the right to make changes without further notice to any products herein.

NXP makes no warranty, representation, or guarantee regarding the suitability of its products for any particular purpose, nor does NXP assume any liability arising out of the application or use of any product or circuit, and specifically disclaims any and all liability, including without limitation consequential or incidental damages. "Typical" parameters that may be provided in NXP data sheets and/or specifications can and do vary in different applications, and actual performance may vary over time. All operating parameters, including "typicals," must be validated for each customer application by customer's technical experts. NXP does not convey any license under its patent rights nor the rights of others. NXP sells products pursuant to standard terms and conditions of sale, which can be found at the following address: nxp.com/SalesTermsandConditions.

While NXP has implemented advanced security features, all products may be subject to unidentified vulnerabilities. Customers are responsible for the design and operation of their applications and products to reduce the effect of these vulnerabilities on customer's applications and products, and NXP accepts no liability for any vulnerability that is discovered. Customers should implement appropriate design and operating safeguards to minimize the risks associated with their applications and products.

NXP, the NXP logo, NXP SECURE CONNECTIONS FOR A SMARTER WORLD, COOLFLUX, EMBRACE, GREENCHIP, HITAG, I2C BUS, ICODE, JCOP, LIFE VIBES, MIFARE, MIFARE CLASSIC, MIFARE DESFire, MIFARE PLUS, MIFARE FLEX, MANTIS, MIFARE ULTRALIGHT, MIFARE4MOBILE, MIGLO, NTAG, ROADLINK, SMARTLX, SMARTMX, STARPLUG, TOPFET, TRENCHMOS, UCODE, Freescale, the Freescale logo, AltiVec, C-5, CodeTEST, CodeWarrior, ColdFire, ColdFire+, C-Ware, the Energy Efficient Solutions logo, Kinetis, Layerscape, MagniV, mobileGT, PEG, PowerQUICC, Processor Expert, QorIQ, QorIQ Qonverge, Ready Play, SafeAssure, the SafeAssure logo, StarCore, Symphony, VortiQa, Vybrid, Airfast, BeeKit, BeeStack, CoreNet, Flexis, MXC, Platform in a Package, QUICC Engine, SMARTMOS, Tower, TurboLink, and UMEMS are trademarks of NXP B.V. All other product or service names are the property of their respective owners. AMBA, Arm, Arm7, Arm7TDMI, Arm9, Arm11, Artisan, big.LITTLE, Cordio, CoreLink, CoreSight, Cortex, DesignStart, DynamIQ, Jazelle, Keil, Mali, Mbed, Mbed Enabled, NEON, POP, RealView, SecurCore, Socrates, Thumb, TrustZone, ULINK, ULINK2, ULINK-ME, ULINK-PLUS, ULINKpro, μ Vision, Versatile are trademarks or registered trademarks of Arm Limited (or its subsidiaries) in the US and/or elsewhere. The related technology may be protected by any or all of patents, copyrights, designs and trade secrets. All rights reserved. Oracle and Java are registered trademarks of Oracle and/or its affiliates. The Power Architecture and Power.org word marks and the Power and Power.org logos and related marks are trademarks and service marks licensed by Power.org.

© 2018 NXP B.V.

Document Number: AN5408
Rev. 6, 09/2018

