



Marathon Treadmill

USER MANUAL



Product may vary slightly from the item pictured due to model upgrades.



**Read all instructions carefully before using this product.
Retain this owner's manual for future reference.**

NOTE:

This manual should not be used to guide your purchasing decision. Your product, and the contents inside its carton, may vary from what is listed in this manual. This manual may also be subject to updates or changes. Updated manuals are available through our website at www.lifespanfitness.com.au



TABLE OF CONTENTS

- I. Important Safety Instructions 03
- II. Important Electrical Information 05
- III. Important Operating Instructions 07
- IV. Assembly Hardware 08
- V. Assembly Instructions 09
- VI. How to Use Safety Key 12
- VII. How to Move the Machine 13
- VIII. Operation Guide 14
- IX. Exercise Guide 19
- X. Maintenance Instructions 21
- XI. Exploded Diagram 25
- XII. Parts List 26
- XIII. Troubleshooting 28
- XIV. Warranty 30
- XV. Hand Pulse Technology 31

I. IMPORTANT SAFETY INSTRUCTIONS

WARNING: Read all instructions before using this treadmill.

It is important your treadmill receives regular maintenance to prolong its useful life. Failing to regularly maintain your treadmill may void your warranty.

DANGER

To reduce the risk of electric shock disconnect your treadmill from the electrical outlet prior to cleaning and/or service work.

DO NOT USE AN EXTENSION CORD:

DO NOT ATTEMPT TO DISABLE THE GROUNDED PLUG BY USING IMPROPER ADAPTERS OR IN ANY WAY MODIFY THE CORD SET.

- Install the treadmill on a flat level surface with access to a 220-240 volt (50/60Hz), grounded outlet.
- Do not operate treadmill on deeply padded, plush or shag carpet. Damage to both carpet and treadmill may result.
- Do not block the rear of the treadmill. Provide a minimum of 1 metre clearance between the rear of the treadmill and any fixed object.
- Place your unit on a solid, level surface when in use.
- When running, make sure the plastic clip is fastened on your clothing. It is for your safety, should you fall or move too far back on the treadmill.
- Keep hands away from all moving parts.
- Never operate the treadmill if it has a damaged power cord or plug. When damaged, these must be replaced by the manufacturer, its service agent or similarly qualified persons in order to avoid a hazard.
- Keep the cord away from heated surfaces.
- Do not operate where aerosol spray products are being used or where oxygen is being administered. Sparks from the motor may ignite a highly gaseous environment.
- Never drop or insert any object into any openings.

- The treadmill is intended for in-home use only and is not suitable for commercial environments.
- To disconnect, turn all controls to the off position, remove the safety key, and then remove the plug from the outlet.
- The pulse sensors are not medical devices. Various factors, including the user's movement, may affect the accuracy of heart rate readings. The pulse sensors are intended only as exercise aids in determining heart rate trends in general.
- Use the handrails provided; they are for your safety.
- Wear proper shoes. High heels, dress shoes, sandals or bare feet are not suitable for use on your treadmill. Quality athletic shoes are recommended to avoid leg fatigue.
- Before undertaking any type of exercise program, it is recommended that you consult a doctor.
- Injuries to health may result from incorrect or excessive training.
- This appliance is not intended for use by persons (including children) with reduced physical, sensory or mental capabilities, or lack of experience and knowledge, unless they have been given supervision or instruction concerning use of the appliance by a person responsible for their safety.
- **WARNING:** Heart rate monitoring systems may be inaccurate. If you feel faint stop exercising immediately.
- Children should not be allowed on or around the equipment, even when not in use.
- Children should be supervised to ensure that they do not play with this machine.
- Loose-fitting clothing or jewellery that could become an entanglement hazard should not be worn.
- Training shoes should be worn when using the equipment.
- Equipment must be used on a level and stable surface.
- All fixings should be checked before the equipment is used.
- All literature relating to the use of the equipment should be retained for future reference.
- Recommended operating temperature: 5-40°C.

! Remove the safety key after use to prevent unauthorized treadmill operation.

II. IMPORTANT ELECTRICAL INFORMATION

WARNING!

- Route the power cord away from any moving part of the treadmill including the elevation mechanism and transport wheels.
- **NEVER** remove any cover without first disconnecting AC power.
- **NEVER** expose this treadmill to rain or moisture. This treadmill is not designed for use outdoors, near a pool, or in any other high humidity environment.
- This is a high-power item; please do not share the same outlet with other high power machines such as, fridges, air conditioning etc. Please choose an outlet exclusively for the machine and make sure the fuse is 10A.

WARNING!

This treadmill requires a right power source to properly operate. For your safety, as well as the safety of others, please verify that the power source is correct before plugging the equipment. Any incorrect power source could cause significant damage to the equipment and or user.

GROUNDING METHODS:

This product must be grounded. Grounding provides the least resistance for electrical current and will reduce the risk of electric shock. The plug must be plugged into an appropriate outlet that is professionally installed and grounded in accordance with all local codes and ordinances. Ensure that the product is connected to an outlet which contains the same configuration as the plug. Do not use an adaptor for this product.

This product is for use on a nominal circuit and has a grounding plug that looks like the plug illustrated in sketch A. Make sure that the product is connected to an outlet having the same configuration as the plug. No adapter should be used with this product.

DANGER

Improper connection of the equipment-grounding conductor can result in risk of electric shock. Check with a certified electrician if you are in doubt as to whether the product is properly grounded. Do not modify the plug provided with the product. If it will not fit the outlet, have a proper outlet installed by an electrician.

WARNING!

- **NEVER** use a ground fault circuit interrupt (GFCI) wall outlet with this treadmill. Route the power cord away from any moving part of the treadmill including the elevation mechanism and transport wheels.
- **NEVER** operate the treadmill using a generator or UPS power supply.
- **NEVER** remove any cover without first disconnecting AC power.
- **NEVER** expose the treadmill to rain or moisture. This treadmill is not designed for use outdoors, near pools or in any other high humidity environment.

GROUNDING METHODS

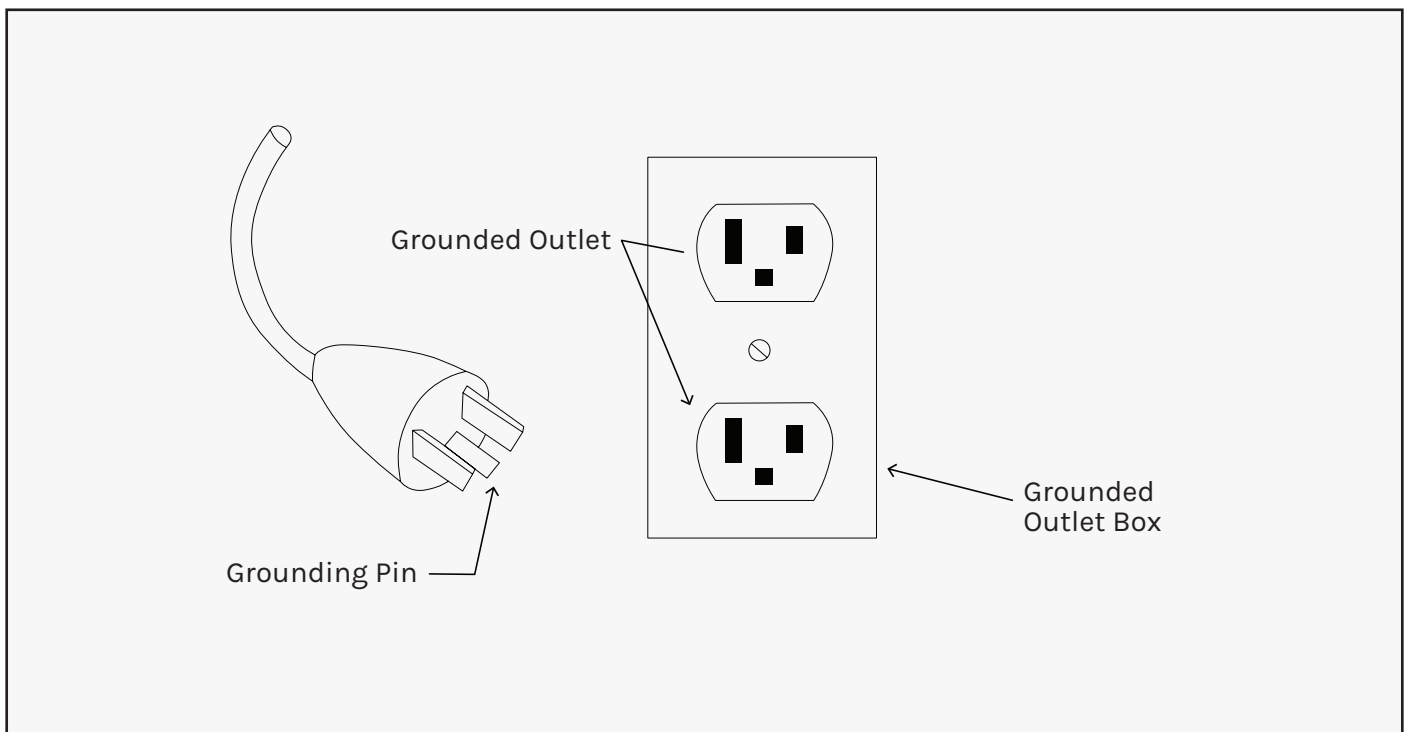

III. IMPORTANT OPERATING INSTRUCTIONS

- Understand that changes in speed and incline do not occur immediately. Set your desired speed on the computer console and release the adjustment key. The computer will obey the command gradually.
- Use caution while participating in other activities while walking on your treadmill, such as watching television, reading, etc. These distractions may cause you to lose balance or stray from walking in the centre of the belt; which may result in serious injury.
- In order to prevent losing balance and suffering unexpected injury, never mount or dismount the treadmill while the belt is moving. This unit starts with at a very low speed. Simply standing on the belt during slow acceleration is proper after you have learned to operate this machine.
- Always hold on to handrail while making control changes.
- A safety key is provided with this machine. Remove the safety key will stop the walking belt immediately; the treadmill will shut off automatically. Inserting the safety key will reset the display.
- Do not use excessive pressure on console control keys. They are precision set to function properly with little finger pressure.
- Replace any defective components immediately. The machine must be kept out of use until repaired.
- Belt wear-in period: all treadmills make a certain type of thumping noise due to the belt riding over the rollers, especially new treadmills. This noise will diminish over time, although may not completely go away. The belt will stretch over time, causing it to ride smoother over the rollers.

IV. ASSEMBLY HARDWARE

CARTON CONTENTS

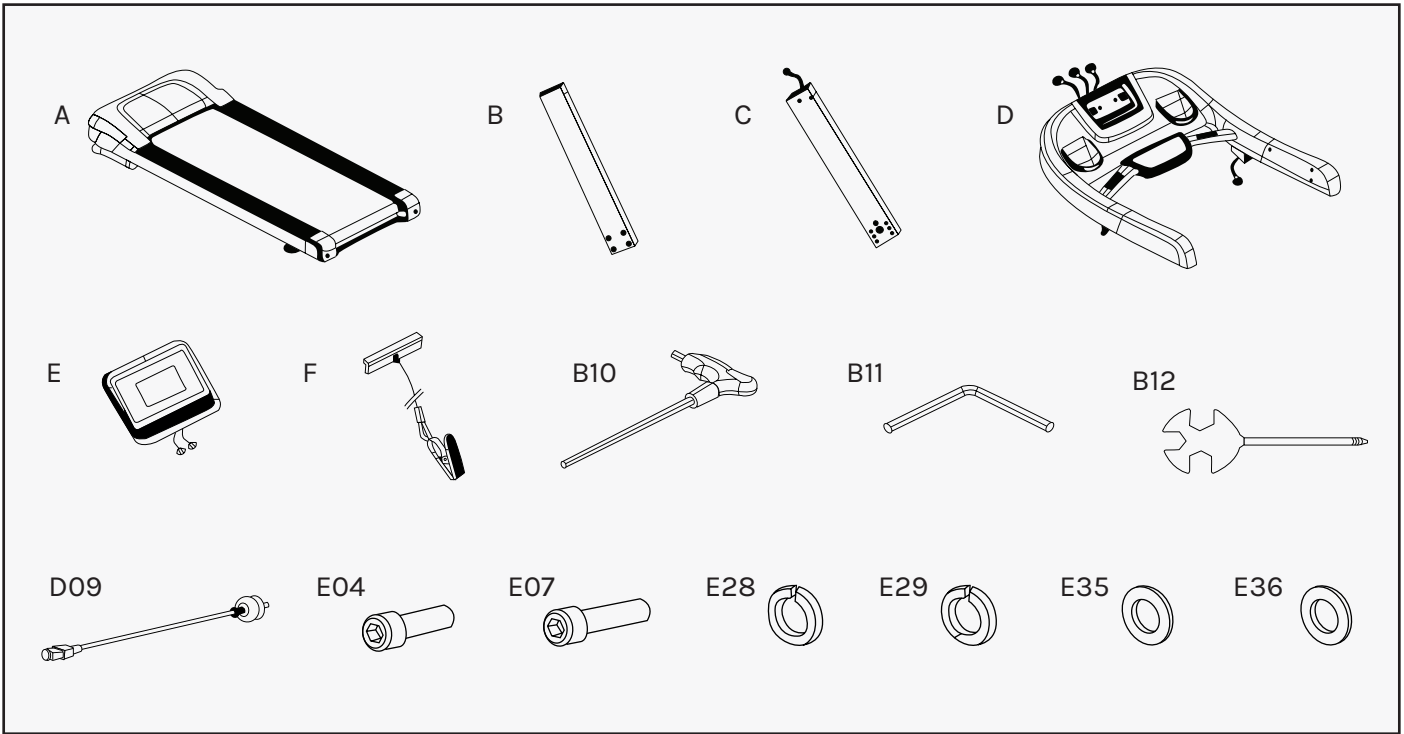

PARTS LIST

No.	Description	Size	Qty	No.	Description	Size	Qty
A	Main Frame		1	D09	Power Wire		1
B	Left Upright Tube		1	E04	Bolt	M10 x 30	14
C	Right Upright Tube		1	E07	Bolt	M8 x 20	2
D	Console Base		1	E28	Spring Washer	10	14
E	Console Panel Set		1	E29	Spring Washer	8	2
F	Safety Key		1	E35	Flat Washer	10	14
B10	T Shape Allen Wrench		1	E36	Flat Washer	8	2
B11	8 #Allen Wrench		1				
B12	Cross Wrench with Screwdriver		1				

ASSEMBLY TOOLS:

T Shape Allen Wrench	1pc
8 #Allen Wrench	1pc
Cross Wrench with Screwdriver S=13, 14, 15	1pc

⚠ NOTE:

Do not connect power before completing assembly.

V. ASSEMBLY INSTRUCTIONS

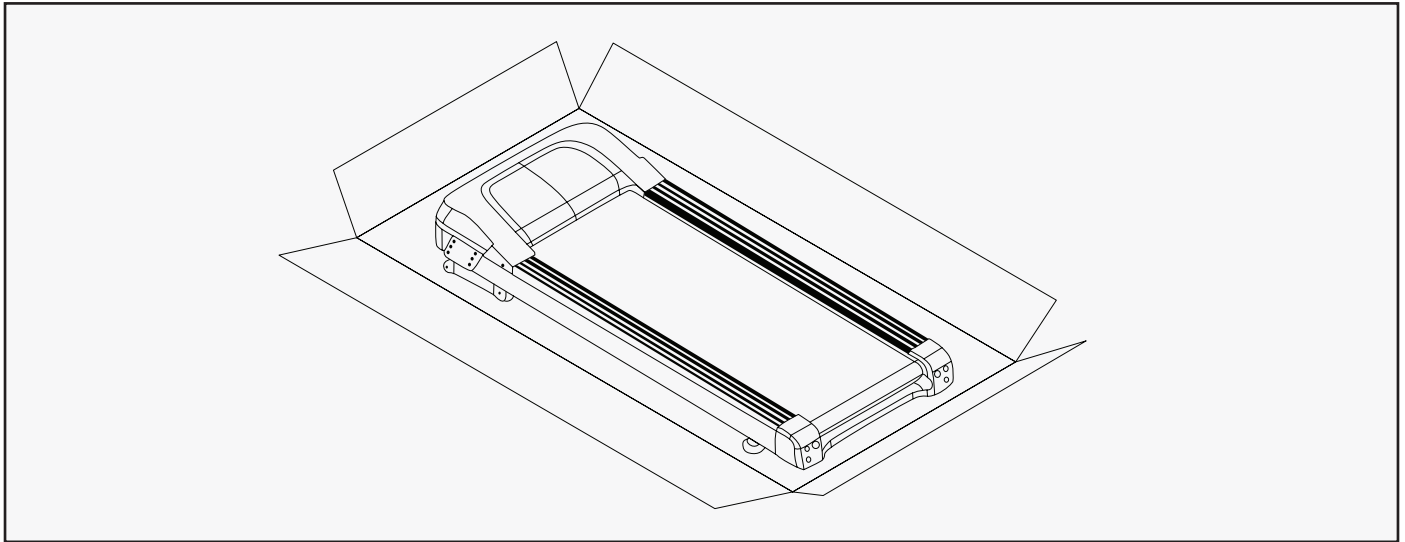

STEP 1

1. Place the Main frame (A) on level ground and ensure that you have a clean workspace that has adequate space.

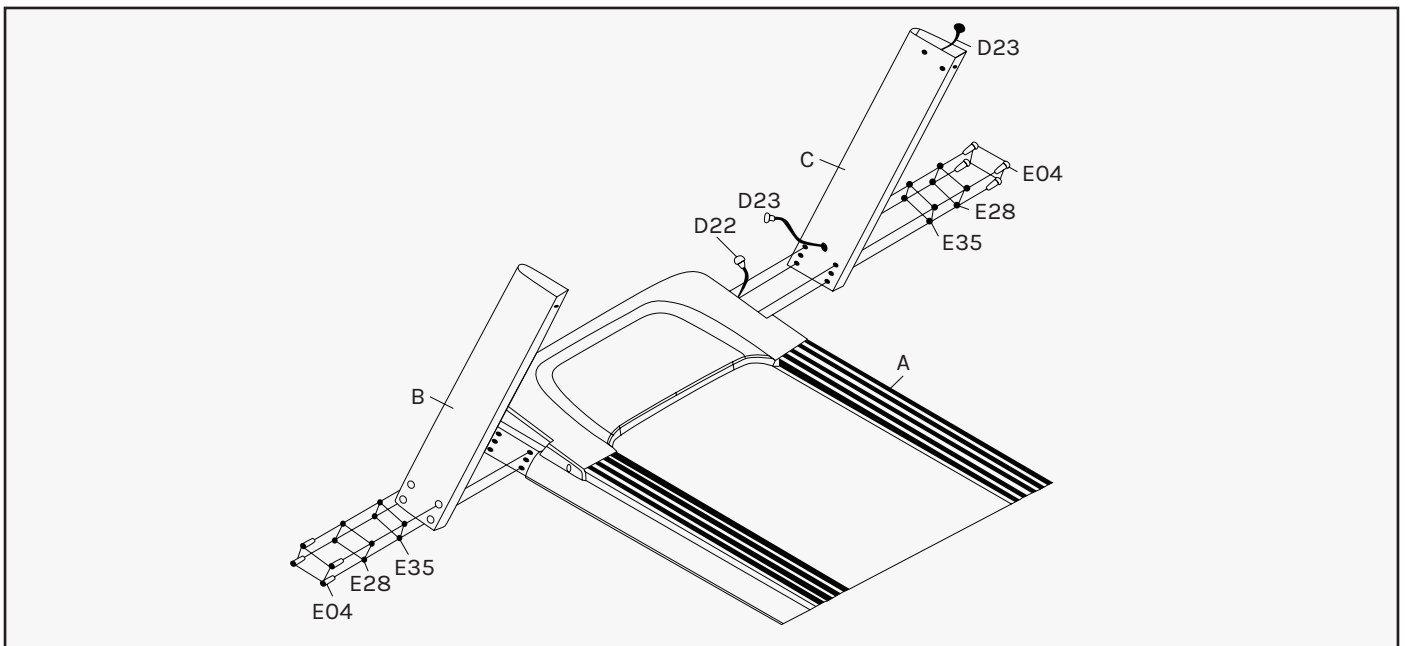

STEP 2

1. Fix the Left upright tube (B) to the main frame (A) with 4 x bolt (E04), 4 x spring washer (E28), 4 x flat washer (E35) by using 8 #Allen wrench (B11).
2. Before assembling the right upright tube, please connect the Console middle signal wire (D23) with Console bottom signal wire (D22).

IMPORTANT: Do not pinch the signal wires during assembly.

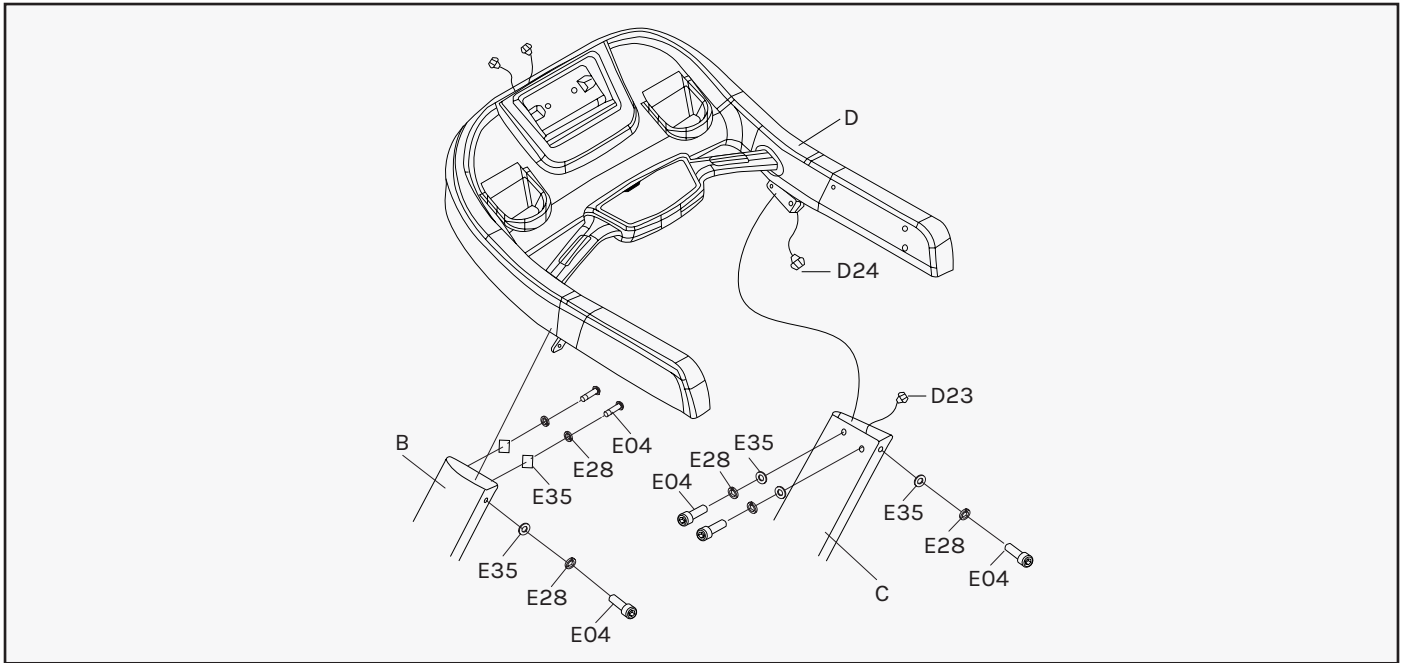

STEP 3

1. Connect the Console middle signal wire (D23) with Console top signal wire (D24). Do not pinch the signal wires during assembly.
2. Fix the Console base (D) to the Left upright tube (B) and Right upright tube (C) with 6 x bolt (E04), 6 x spring washer (E28), 6 x flat washer (E35) by using 8 #Allen wrench (B11).

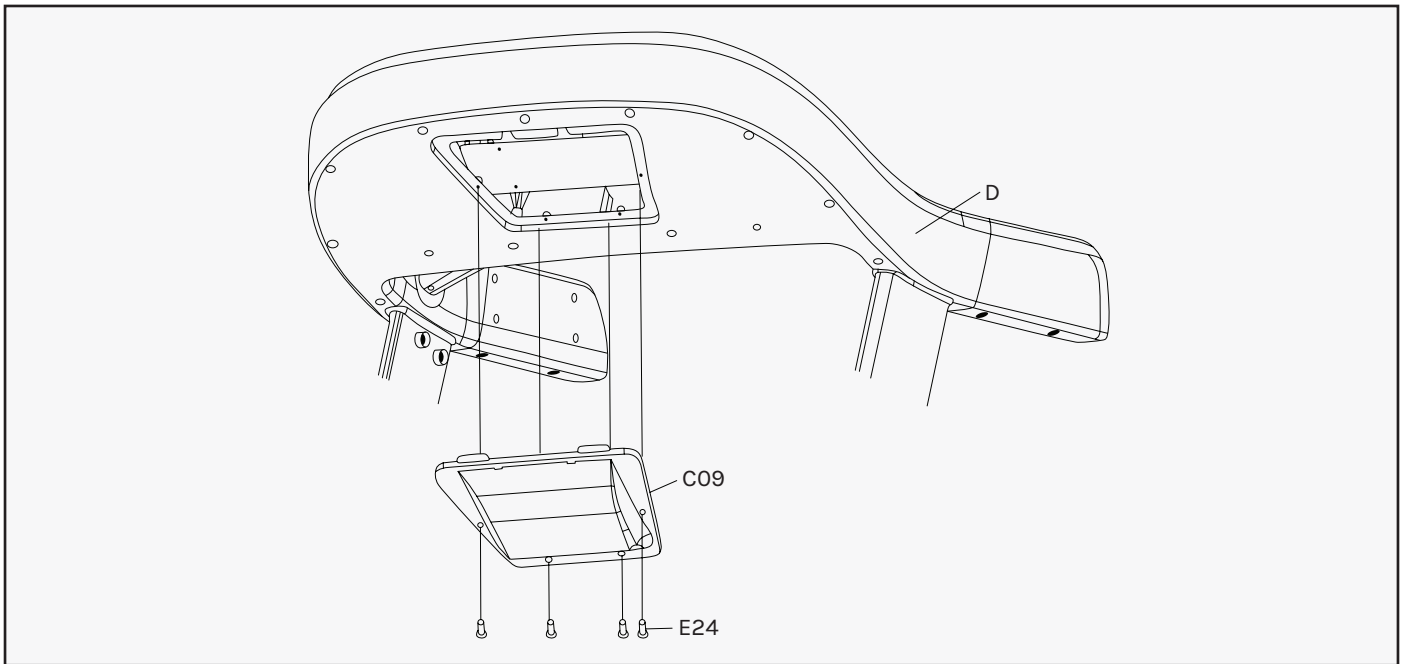

STEP 4

1. Disassemble the Console back cover (C09). Loosen 4 x screw (E24) and remove the Console back cover (C09) by using cross wrench with screwdriver (B12).

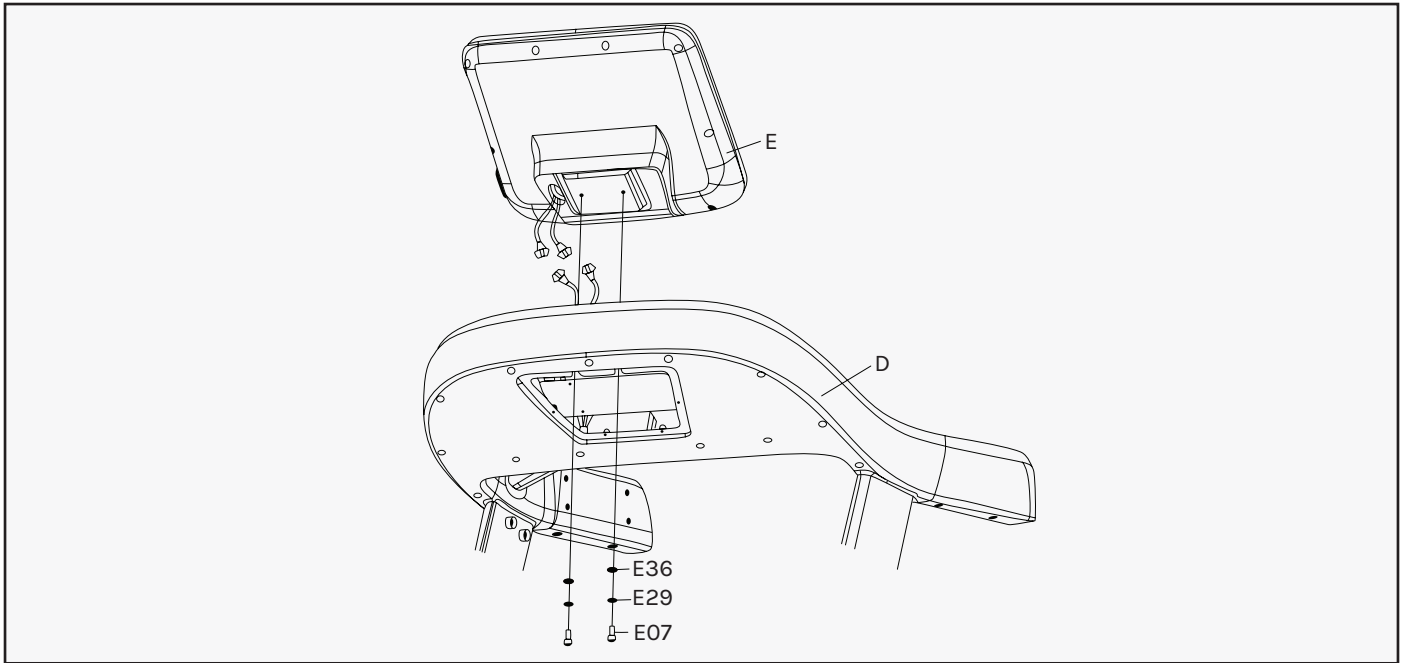

STEP 5

1. Connect the signal wires before assembling the Console panel set (E).
2. Fix the Console panel set (E) to the Console base (D) with 2 x bolt (E07), 2 x spring washer (E29), 2 x flat washer (E36) by using T shape Allen wrench (B10).

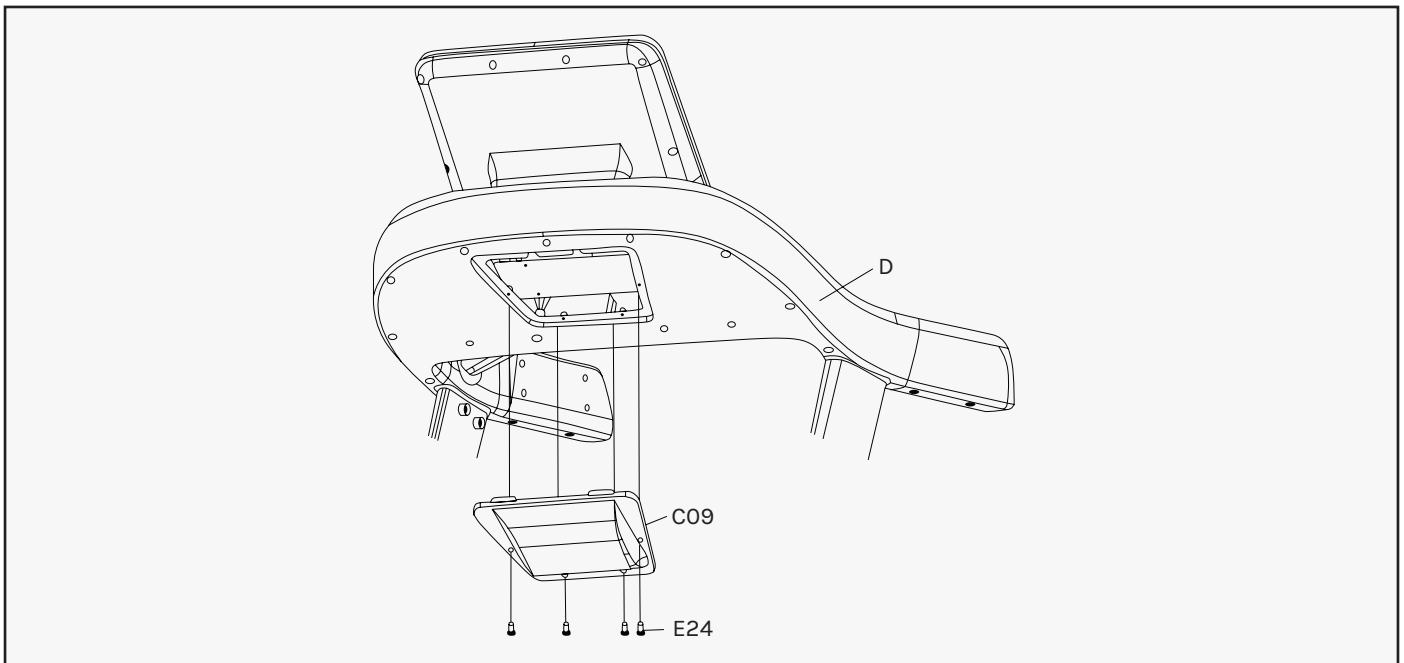

STEP 6

1. Fix the Console back cover (C09) to the Console base (D) with 4 x screw (E24) by using cross wrench with screwdriver (B12).

VI. HOW TO USE SAFETY KEY

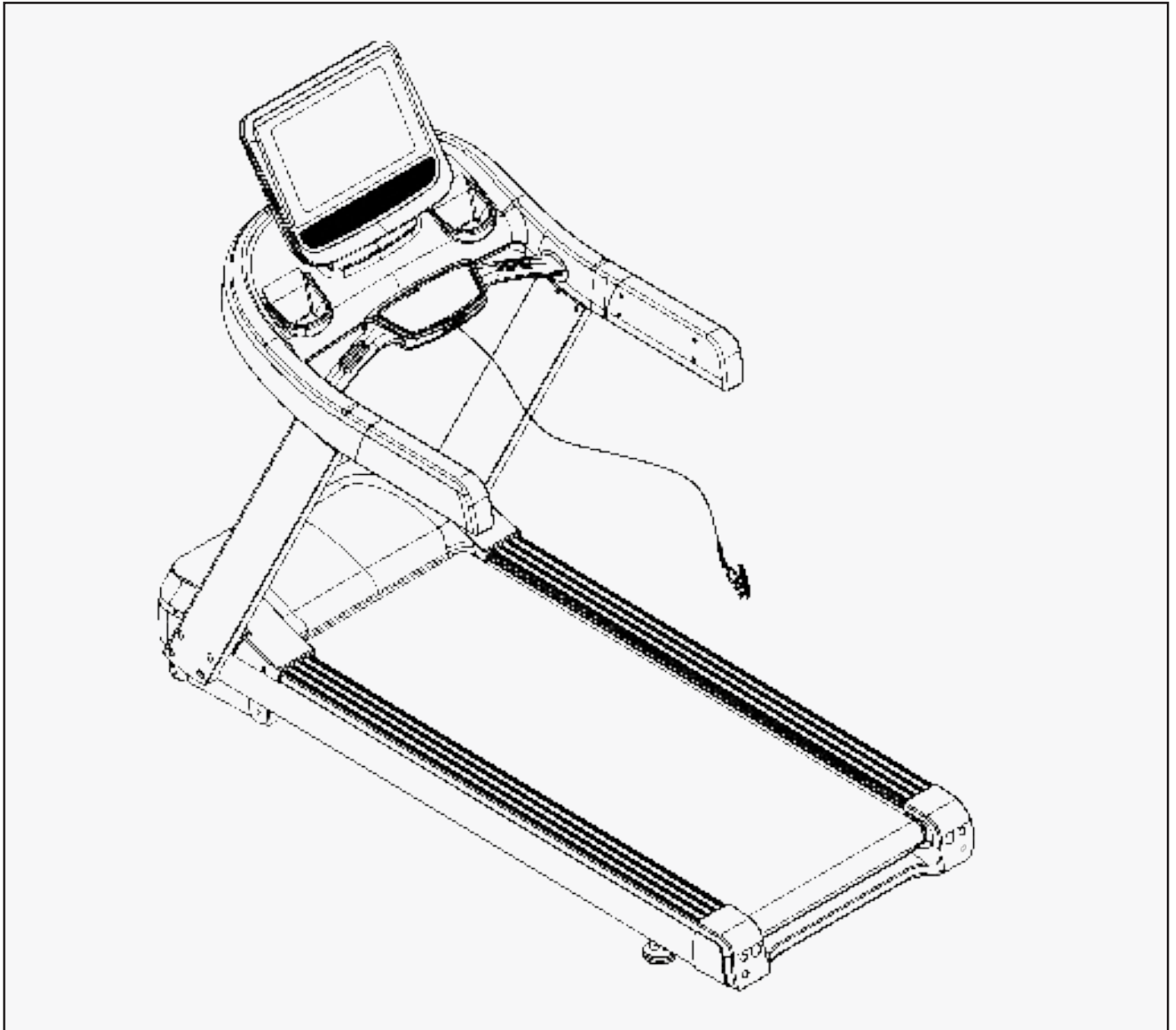

1. Before running, please clip the safety key to your cloth.
2. For any emergency, please pull the safety key rope and the machine will stop. The key must be placed back on to start the machine.

VII. HOW TO MOVE THE MACHINE

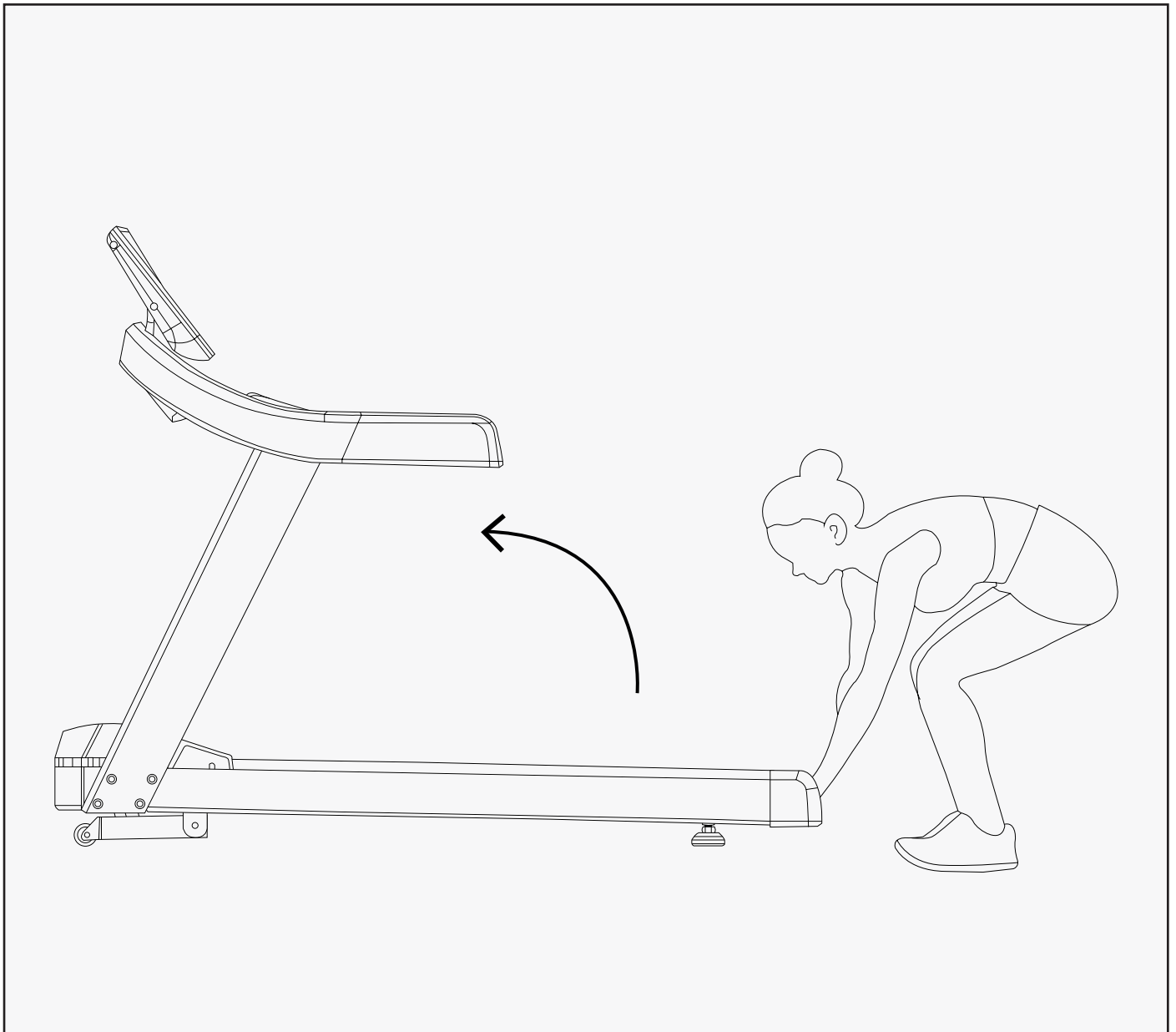

! **NOTE:**

This Treadmill can be moved by lifting the back end (roller end), pivoting the product onto the transport wheels and will be heavy to lift. Please take caution during lifting, seek assistance with another person (2-person lift) if possible.

VIII. OPERATION GUIDE

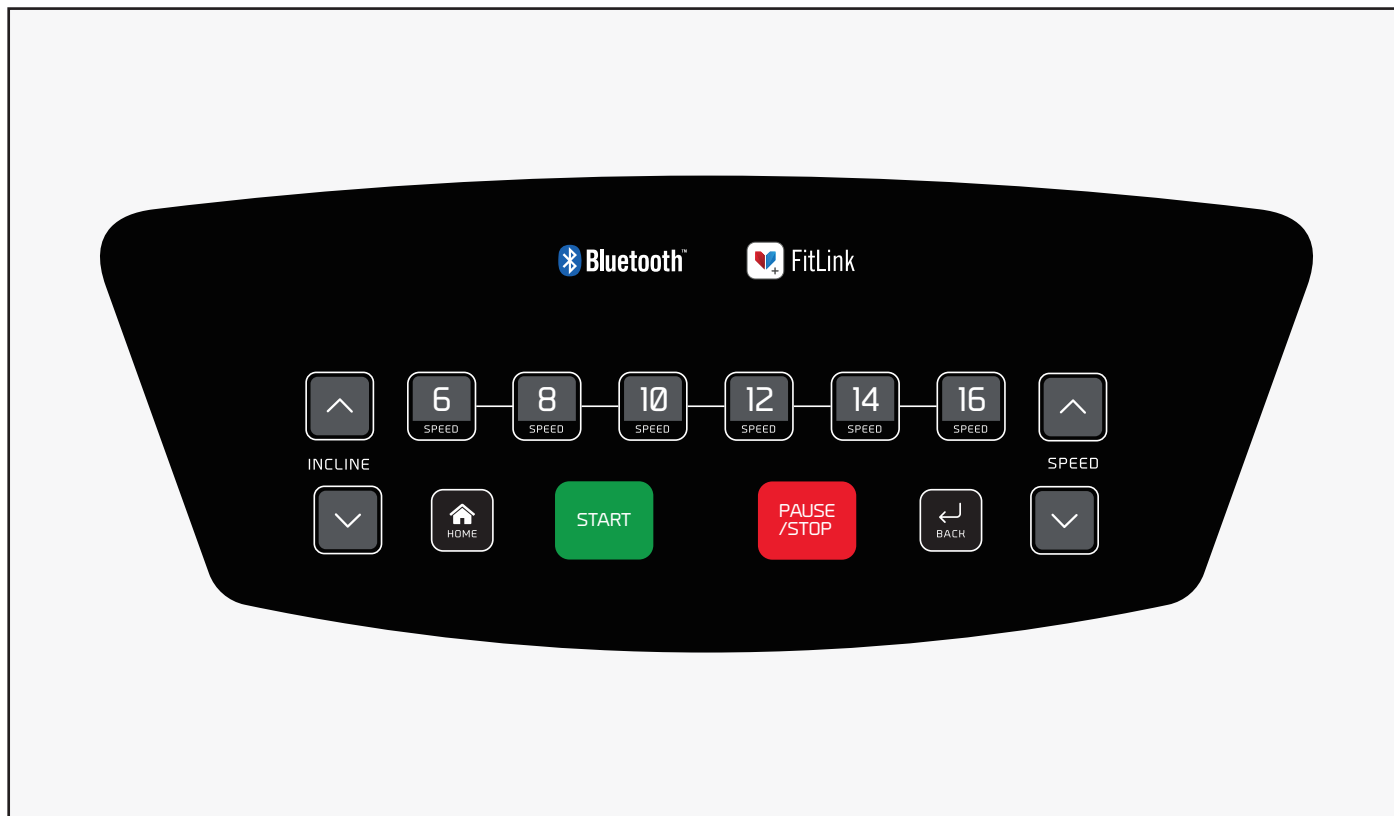

BUTTON FUNCTIONS

1. **INCLINE+ / INCLINE-**: Press this button to adjust the incline.
2. **INSTANT SPEED**: Press 6-8-10-12-14-16 to choose speed quickly.
3. **HOME**: Press this button to return to the main page.
4. **START**: Press this button at any time to start the machine.
5. **STOP / PAUSE**: Press this button to stop or pause the machine.
6. **BACK**: Press this button to return to the previous page.
7. **SPEED+ / SPEED-**: Press this button to adjust the speed.

COMPUTER FUNCTIONS

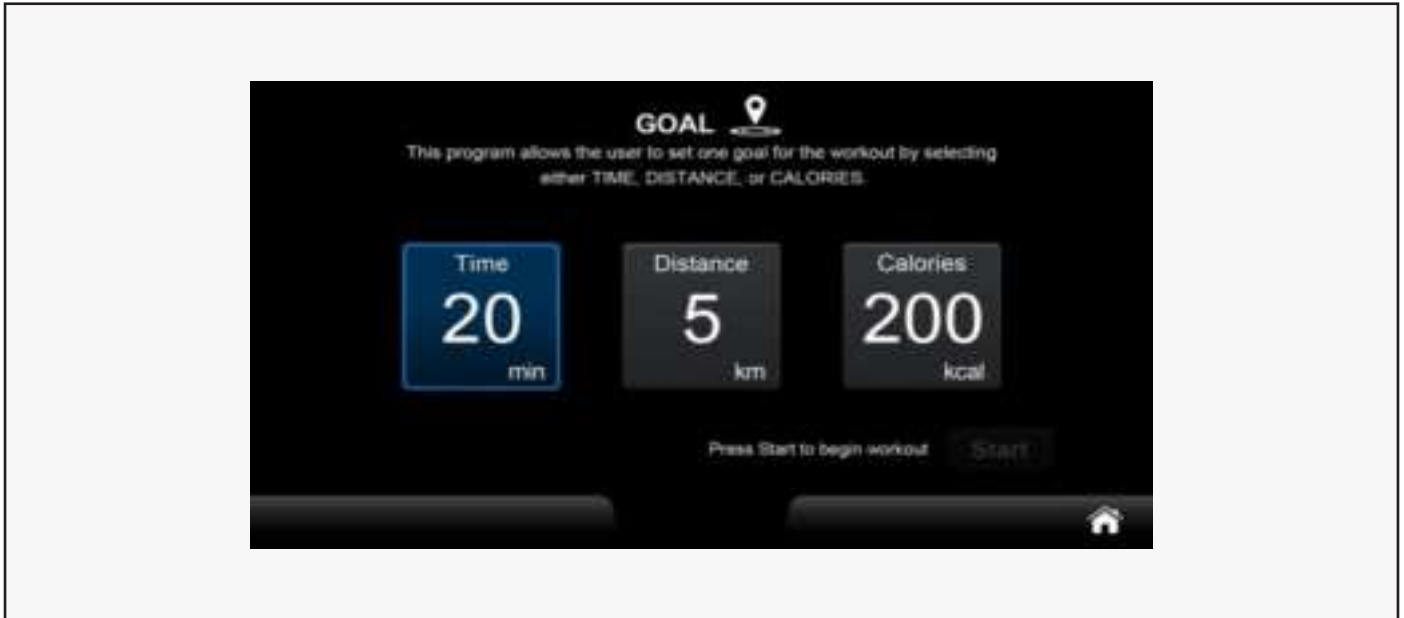

1. GOAL

When you press the GOAL button, and the console will show as below, you can select one of Time, Distance and Calories. Once you have confirmed one, then you can set the value you want.

Press Start to start the running.



2. PROGRAM

When you press the PROGRAM button, and the console will show as below, then you can set the value of Gender, Age, Weight and Time.

Press Next to profile chart.

Press Start to begin workout.



3. SETTING

You can set the System, Bluetooth, Wireless and Lock setting.



4. HRC

When you press the HRC button, and the console will show as below, then you can set the value of Gender, Age, Weight and Time.

Press Next to select HRC.

Press Start to begin workout.



5. USER PROGRAM

When you press the USER PROGRAM button, and the console will show as below, then you can set the value of Gender, Age, Weight and Time.

Press Start to begin workout.

6. QUICK START

Press the button of QUICK START, then you can start the machine quickly.

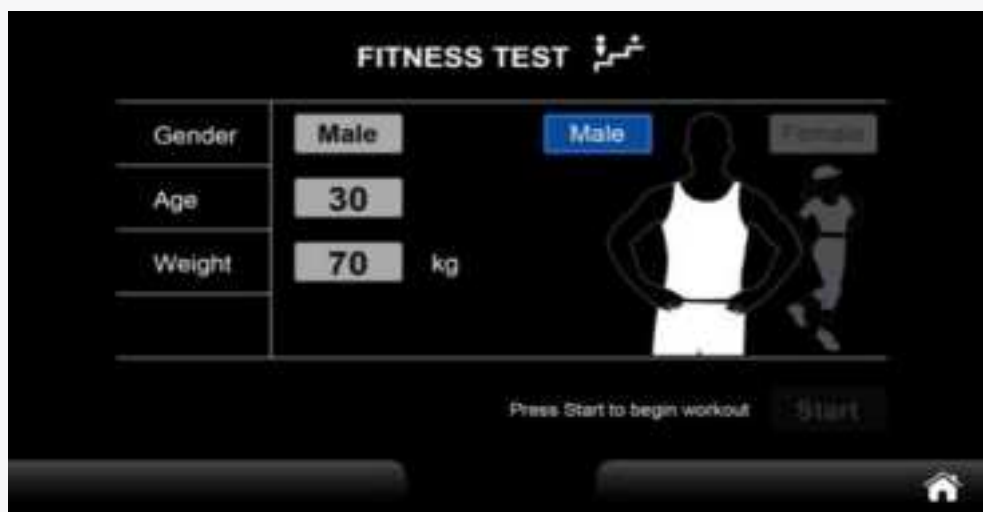

7. FITNESS TEST

When you press the FITNESS TEST button, and the console will show as below, then you can set the value of Gender, Age, Weight.

Press Start to begin workout.

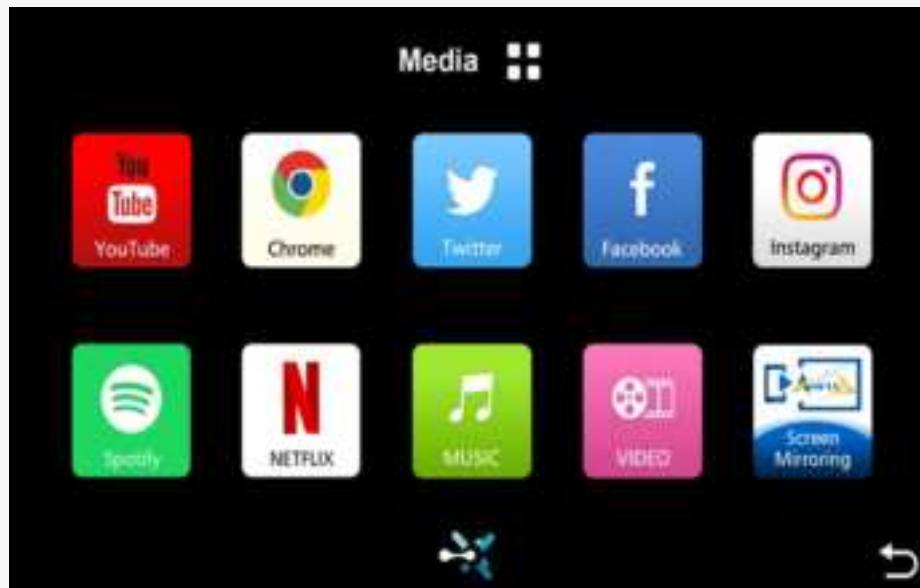

8. MEDIA

When you press MEDIA button, you can see as below:

YouTube, Chrome, Twitter, Facebook, Instagram, Spotify, NETFLIX, MUSIC, VIDEO, Screen Mirroring.

SAFETY LOCK FUNCTION

Under any mode if you pull away the safety key the machine will stop. The window will show a warning with reminding sound. The machine cannot work until safety key is inserted back.

POWER SAVE FUNCTION

The machine is with energy saving function. Under standby mode, at the state of waiting for operation, if without any operation, the saving on power function will be available after 5 minutes, the display will shut down. You can press any button to turn on the display.

POWER ON (I) AND POWER OFF (O)

Switch off the power: You can switch off the power to turn off the treadmill.

CAUTION:

1. We recommend that you maintain a slow speed at the beginning of a session and hold on to the handrails until you become comfortable and familiar with the treadmill.
2. Attach the magnet end of the safety pulling rope to the computer and attach the clip of the safety pulling rope to your clothing.
3. To end your workout safely, press the STOP button or pull out the safety pulling rope, then the treadmill will stop immediately.

IX. EXERCISE GUIDE

! PLEASE NOTE:

Before beginning any exercise program, consult your physician. This is important especially if you are over the age of 45 or individuals with pre-existing health problems.

The pulse sensors are not medical devices. Various factors, including the user's movement, may affect the accuracy of heart rate readings. The pulse sensors are intended only as an exercise aid in determining heart rate trends in general.

Exercising is a great way to control your weight, improve your fitness and reduce the effect of aging and stress. The key to success is to make exercise a regular and enjoyable part of your everyday life.

The condition of your heart and lungs and how efficient they are in delivering oxygen via your blood to your muscles is an important factor to your fitness. Your muscles use this oxygen to provide enough energy for daily activity. This is called aerobic activity. When you are fit, your heart will not have to work so hard. It will pump a lot fewer times per minute, reducing the wear and tear of your heart.

So as you can see, the fitter you are, the healthier and greater you will feel.

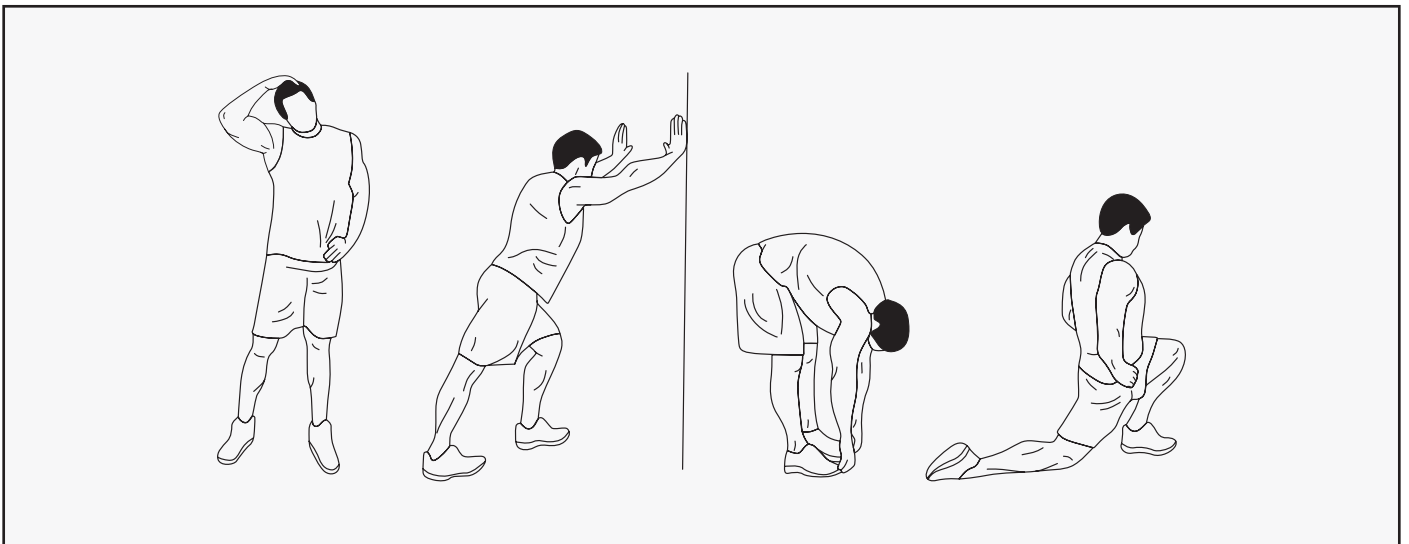

WARM UP

Start each workout with 5 to 10 minutes of stretching and some light exercises. A proper warm-up increases your body temperature, heart rate and circulation in preparation for exercise. Ease into your exercise.

TRAINING ZONE EXERCISE

After warming up, increase the intensity to your desired exercise program. Be sure to maintain your intensity for maximum performance. Breathe regularly and deeply as you exercise.

COOL DOWN

Finish each workout with a light jog or walk for at least 1 minute. Then complete 5 to 10 minutes of stretching to cool down. This will increase the flexibility of your muscles and will help prevent post-exercise problems.

WORKOUT GUIDELINES

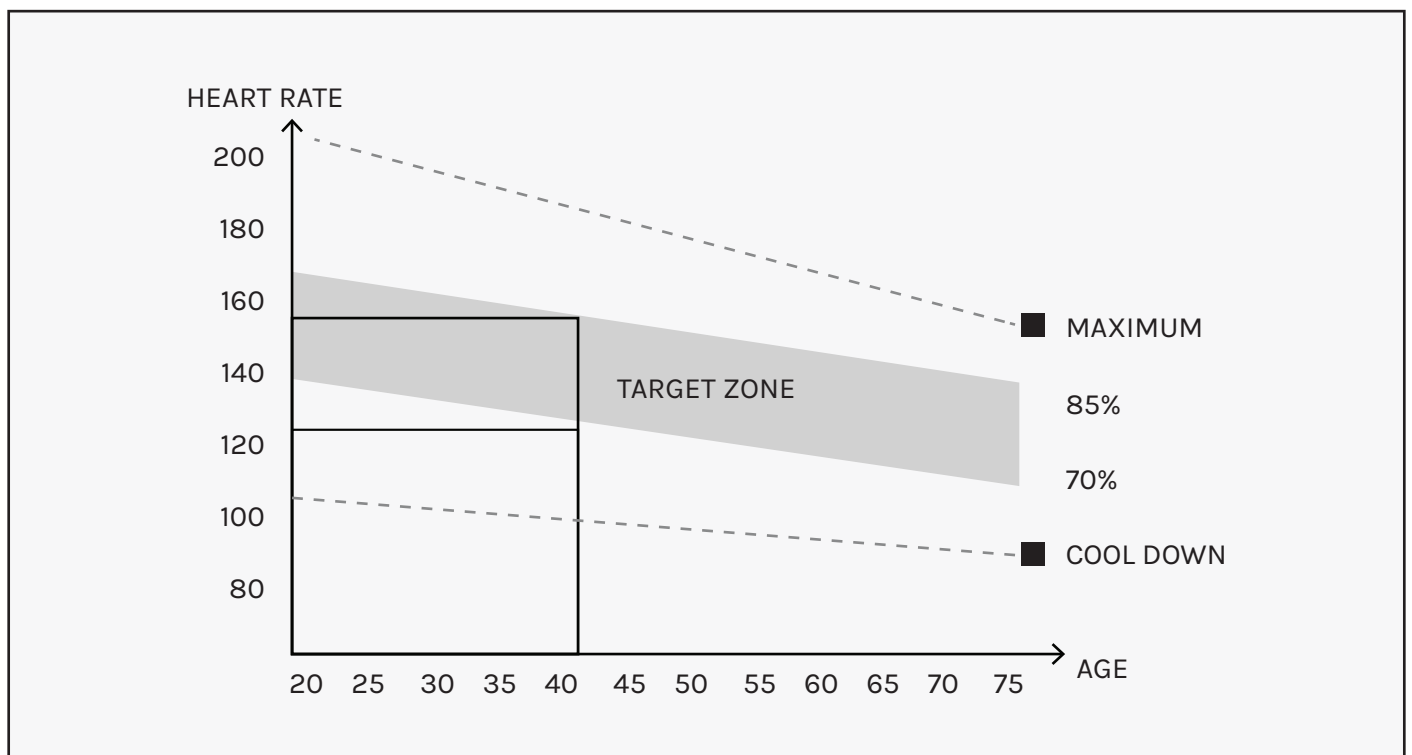

! This is how your pulse should behave during general fitness exercise. Remember to warm up and cool down for a few minutes.

The most important factor here is the amount of effort you put in. The harder and longer you work, the more calories you will burn.

X. MAINTENANCE INSTRUCTIONS

Reasonable cleaning/lubricating should be made to extend the life time of this unit. Performance is maximized when the belt and mat are kept as clean as possible.

WARNING:

- The mat/deck friction may lay a major role in the function and life of your treadmill and that is why we recommend you constantly lubricate this friction point to prolong the useful life of your treadmill. Failing to do this may void your warranty.
 - Unplug power cord before maintenance.
 - Stop treadmill before folding.
-

1. GENERAL CLEANING

- Use a soft, damp cloth to wipe the edge of the belt and the area between the belt edge and frame. A mild soap and water solution along with a nylon scrub brush will clean the top of the textured belt. This task should be done once a month. Allow to dry before using.
- On a monthly basis, vacuum underneath your treadmill to prevent dust build up. Once a year, you should remove the black motor shield and vacuum out dirt that may accumulate.

2. GENERAL CARE

- Check parts for wear before use.
- Pay particular attention to the fixing knobs and make sure they are tight.
- Always replace the mat if worn and any other defective parts.
- If in doubt do not use the treadmill and contact us.

 **Take care to protect carpets and floor** in case of leakages. This product is a machine that contains moving parts which have been greased/lubricated and could leak.

3. BELT/DECK/ROLLER LUBRICATION

The mat/deck friction may play a major role in the function and life of your treadmill and that is why we recommend you constantly lubricate this friction point to prolong the useful life of your treadmill. You should apply lubrication after approximately the first 30 hours of operation.

We recommend lubrication of the deck according to the following timetable:

- Light use (less than 3 hours per week) every 6 months.
- Medium use (3-5 hours a week) every 3 months.
- Heavy use (more than 5 hours per week) every 6-8 weeks.

See below procedures for lubricating:

1. Use a soft, dry cloth to wipe the area between the belt and deck.
2. Spread lubricant onto the inside surface of belt and deck evenly (make sure the machine is turned off and power is disconnected).
3. Periodically lubricate the front and rear rollers to keep them at their peak performance. If the treadmill belt/deck/roller is kept reasonably clean it is possible to expect over 1200 hours before relubricating is necessary.

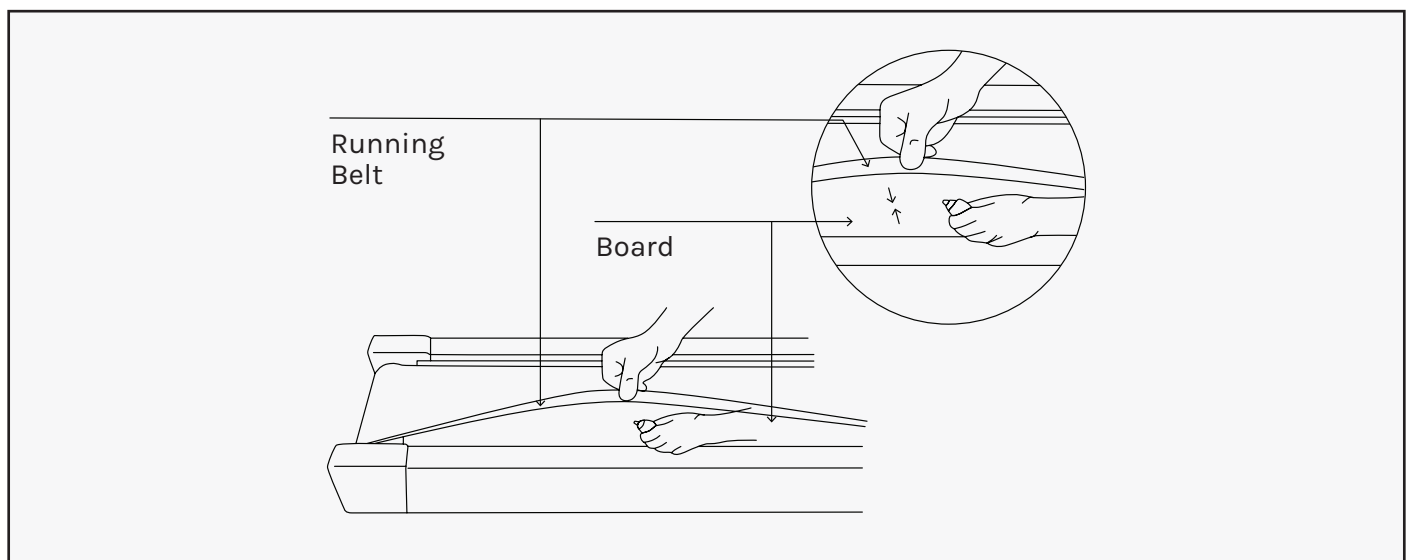

Video Tutorial Available at: <http://youtu.be/cP9NtFHfWlc>

Lifespan Fitness YouTube Channel: <http://www.youtube.com/user/treadmillsvideos>

4. HOW TO CHECK THE RUNNING MAT FOR PROPER LUBRICATION

1. Disconnect the main power supply.
2. Fold the treadmill up into the storage position.
3. Feel the underside surface of the running mat.

If the surface is slick when touched, then no further lubrication is needed.

If the surface is dry to the touch, apply a suitable silicone lubricant.

! We recommend that you use a silicone based spray to lubricate your treadmill.
This can be purchased directly from us or any hardware store.

5. CENTERING THE RUNNING BELT

Place the treadmill on level ground and set it at 6-8km/h to check if the Running Belt drifts.

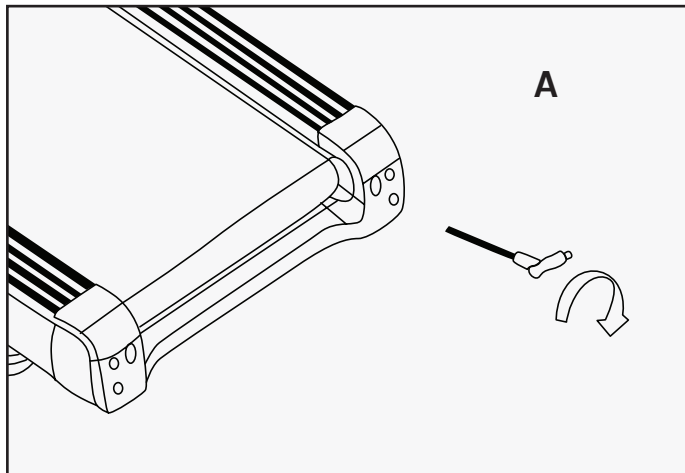

If the Running Belt moves to the right, unplug safety key and power switch, then turn the adjusting bolt on the right side 1/4 turn clockwise. Plug in the power switch and safety key and run the treadmill. If the belt does not move, repeat this step until it centers.

Refer to Figure A

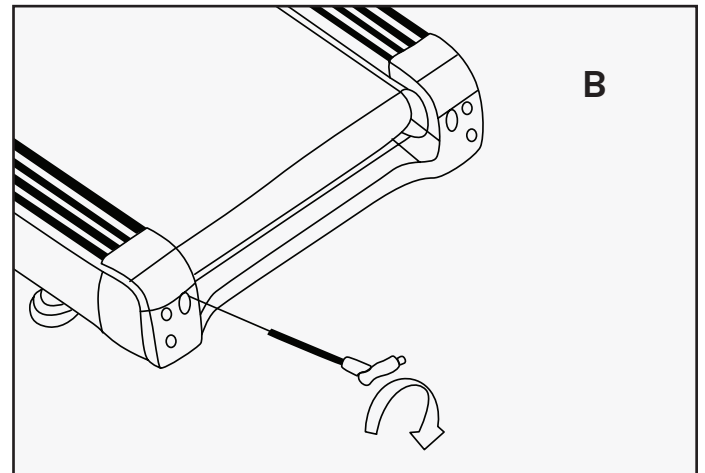

If the Running Belt moves to the left, unplug safety key and power switch, then turn the adjusting bolt on the right side 1/4 turn clockwise. Plug in the power switch and safety key and run the treadmill. If the belt does not move, repeat this step until it centers.

Refer to Figure B

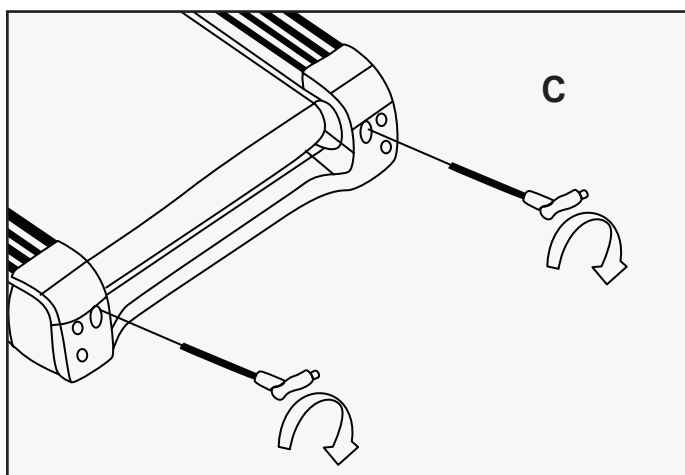

Over time the Running Belt will loosen. To tighten the belt turn the Left & Right side adjustment bolts 1/4 turn clockwise, check the tension of the belt. Continue this process until belt is at the correct tension. Make sure to adjust both sides equally to ensure correct belt alignment.

Refer to figure C.

! **NOTE:**

When properly tightened, you should be able to peel the very edge of the side of the belt up approximately 2 inches. However, this is a rough reference and not all treadmills are the same. Some treadmills that have longer belts may give different measurements for correct belt tightness.

Simply, if the belt begins to slip during use, this is an indication that the belt still needs tightening.

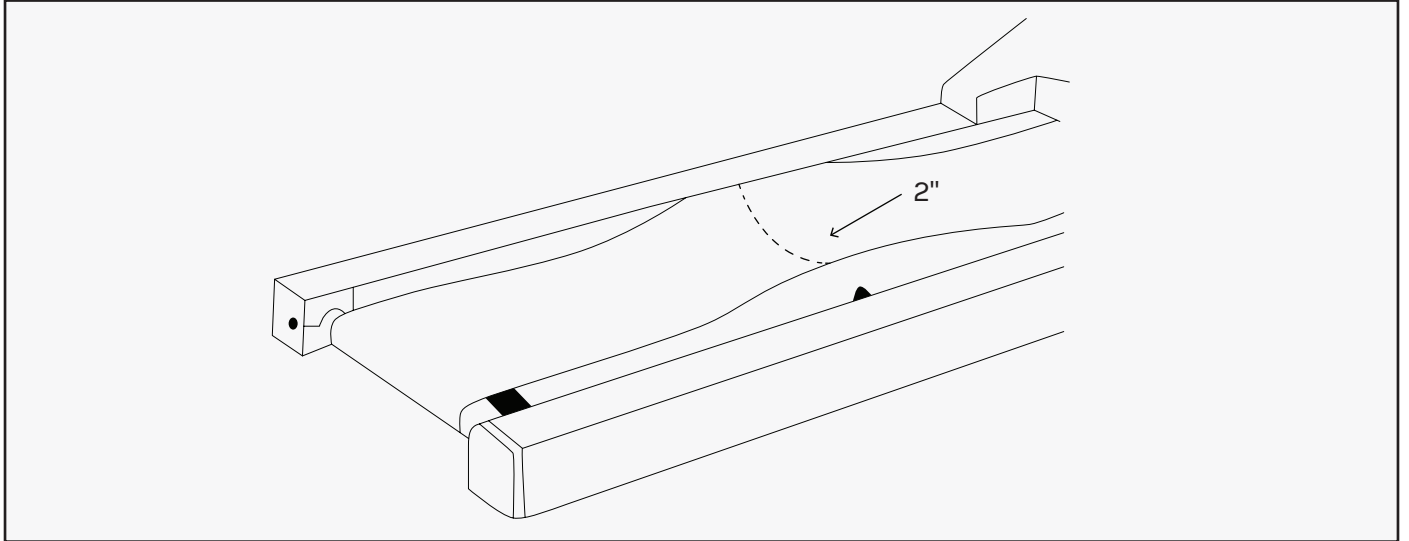

Video Tutorial Available at: <http://youtu.be/vllsamTSvva>

Lifespan Fitness YouTube Channel: <http://www.youtube.com/user/treadmillsvideos>

XI. EXPLODED DIAGRAM

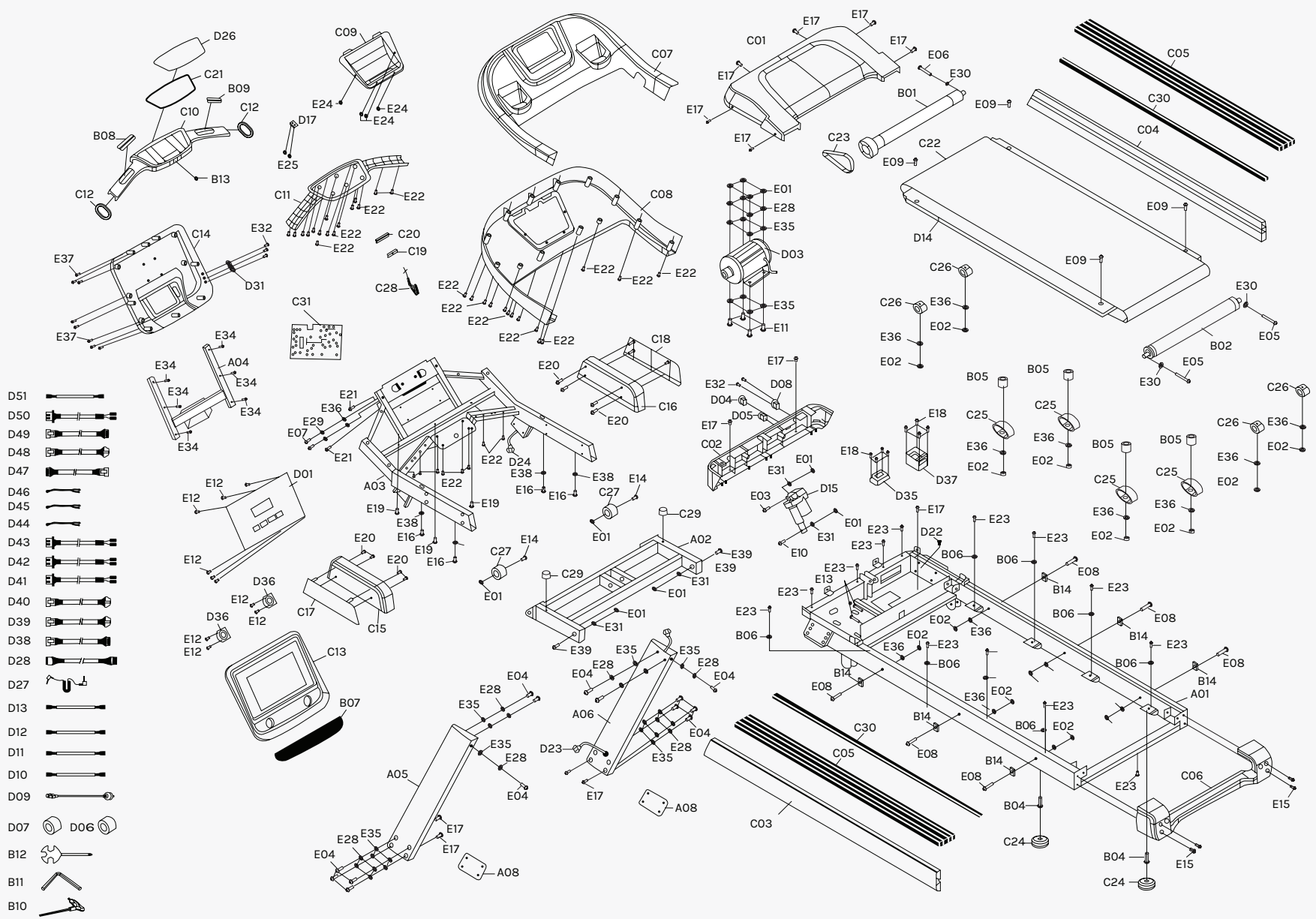

XII. PARTS LIST

No.	Description	Size	Qty	No.	Description	Size	Qty
A01	Main Frame		1	C17	Handle Bard Side Cover(L)		1
A02	Incline Bracket		1	C18	Handle Bard Side Cover(R)		1
A03	Console Bracket		1	C19	Safety Key		1
A04	Console Top Bracket		1	C20	Safety Key Bracket		1
A05	Upright Tube (L)		1	C21	Front Handrail Panel		1
A06	Upright Tube (R)		1	C22	Running Belt		1
A08	Upright Clamping Plate		2	C23	Motor Belt		1
B01	Front Roller		1	C24	Versatile Foot Pad		2
B02	Back Roller		1	C25	Elliptical Cushion		4
B04	Adjustment Pole		2	C26	Cushion		4
B05	Compression Spring 1		4	C27	Wheel		2
B06	Side Rail Washer		8	C28	Safety Key Clip		1
B07	Speaker Net		1	C29	Tapered Cushion		2
B08	Pulse Steel Plate 1		2	C30	Control Keyboard		2
B09	Pulse Steel Plate 2		2	C31	15.6" Binder Plate		1
B10	T Shape Allen Wrench		1	D01	Console PCB Board		1
B11	8 #Allen Wrench		1	D03	AC Motor		1
B12	Cross Wrench with Screwdriver		1	D04	Switch Button		1
B13	Safety Key Plate		2	D05	Overload Protector		1
B14	Side Rail Pressing Sheet		6	D06	Magnet Ring		1
C01	Motor Top Cover		1	D07	Magnet Core		1
C02	Motor Front Cover		1	D08	Power Socket		1
C03	Side Rail (L)		1	D09	Power Wire		1
C04	Side Rail (R)		1	D10	AC Single Wire (Blue)		2
C05	Top Side Rail		2	D11	AC Single Wire (Brown)		2
C06	Back-end Cover		1	D12	AC Single Wire (Brown)		1
C07	Console Top Cover		1	D13	Grounding Wire		1
C08	Console Bottom Cover		1	D14	Running Board		1
C09	Console Back Cover		1	D15	Incline Motor		1
C10	Front Handrail Top Cover		1	D26	Function Board		1
C11	Front Handrail Bottom Cover		1	D27	MP3 Wire		1
C12	Handle Bar Decoration Ring		2	D28	USB Connecting Wire		1
C13	Panel Top Cover		1	D31	USB Board		1
C14	Panel Bottom Cover		1	D35	Inverter		1
C15	Left Handrail Foam		1	D36	Speaker		2
C16	Right Handrail Foam		1	D38	Communication Top Wire		1

No.	Description	Size	Qty	No.	Description	Size	Qty
D39	Communication Middle Wire		1	E11	Bolt	M10x4525	4
D40	Communication Bottom Wire		1	E12	Bolt	ST4.2x8	14
D41	Hand Pulse Top Wire		1	E13	Bolt	M8x55	2
D42	Handle Pulse Middle Wire		2	E14	Bolt	M10x70 L30	2
D43	Handle Pulse Bottom Wire		2	E15	Bolt	M6x15	4
D44	Safety Key Top Wire		1	E16	Bolt	M5x16	4
D45	Safety Key Middle Wire		1	E17	Bolt	M5x8	13
D46	Safety Key Bottom Wire		1	E18	Bolt	M4x12	8
D47	Keyboard Top Wire		1	E19	Screw	ST4.2x30	3
D48	Keyboard Middle Wire		1	E20	Screw	ST4.2x25	8
D49	Keyboard Bottom Wire		1	E21	Screw	ST4.2x20	2
D50	Wireless Pulse Bottom Wire		1	E22	Screw	ST4.2x15	43
D51	Audio Input Connecting Wire		1	E23	Screw	ST4.2x12	13
E01	Nut	M10	10	E24	Screw	ST4.2x12	4
E02	Nut	M8	14	E25	Screw	ST2.5*6.0	4
E03	Bolt	M10x45 L30	1	E28	Spring Washer	10	18
E04	Bolt	M10x30	14	E29	Spring Washer	8	2
E05	Bolt	M8x80	2	E30	Lock Washer	8	3
E06	Bolt	M8x65	1	E31	Lock Washer	10	6
E07	Bolt	M8x20	2	E32	Screw	ST2.9x8	6
E08	Bolt	M8x55 L20	6	E34	Screw	ST4.2x25	6
E09	Bolt	M8x25	4	E35	Flat Washer	10	22
E10	Bolt	M10x110 L20	1	E36	Flat Washer	8	22
				E37	Screw	ST4.2x12	9
				E38	Big Washer	5	4
				E39	Bolt	M10x55 L15	2

XIII. TROUBLESHOOTING

Problem	Possible Cause	Suggested Action
E01: Message Failure	Inverter cannot receive the signal from PCB board.	<ol style="list-style-type: none"> 1. Check signal wires between the console and inverter to make sure the connection is well. 2. Power off for 2 minutes, then power on again. 3. Please replace the inverter if it still cannot work.
E02: Over Current	The running belt and motor were stuck.	<ol style="list-style-type: none"> 1. Power off for 5 minutes, then power on again. 2. Check and make sure the treadmill is not overload. 3. Check whether the running belt needs oil, whether the running belt is seriously worn, and whether the transmission mechanism (drum, etc.) is abnormal. 4. Please contact the customer service if it still cannot work.
E04: Over Voltage	The incoming voltage is too low or too high.	<ol style="list-style-type: none"> 1. Power off to check the incoming voltage is correct. 2. Power off for 1 minute, then power on again, if it still cannot work, please contact the customer service.
E08: Overload	The treadmill is overload. The running belt and motor were stuck.	<ol style="list-style-type: none"> 1. Check and make sure the treadmill is not overload. 2. Check whether the running belt needs oil, whether the running belt is seriously worn, and whether the transmission mechanism (drum, etc.) is abnormal.
E10: Inverter Problem	<ol style="list-style-type: none"> 1. Wires from the motor and inverter does not connect properly. 2. Inverter abnormality. 	<ol style="list-style-type: none"> 1. Check to make sure power on. 2. Check to make sure the inventor is not loaded. 3. Check to make sure the inventor temperature is not too high. 4. Please change inverter if it still cannot work.

Problem	Possible Cause	Suggested Action
E18: Current Sensor U failure	Inverter abnormality.	<ol style="list-style-type: none"> 1. Power off for 2 minutes, then power on again. 2. Please change inverter if it still cannot work.
E80: Inverter Overheat	The temperature of the inverter is too high.	<ol style="list-style-type: none"> 1. Improve the ventilation of the equipment and clean the radiator fin of the inverter. 2. Replace the fan of the inverter (the fan starts when the inverter reaches 50 degrees) 3. If it still cannot work, please contact the customer service.
E81: Message Failure	Inverter has received the startup signal, but it hasn't received the previous stop signal.	<ol style="list-style-type: none"> 1. Power off for 2 minutes, then power on again. 2. If it still cannot work, please contact the customer service.
E88: Current Sensor W Failure	Inverter abnormality.	<ol style="list-style-type: none"> 1. Power off for 2 minutes, then power on again. 2. Please change inverter if it still cannot work.
E40: Incline Problem	Incline learning defeated.	<ol style="list-style-type: none"> 1. Check whether the VR wire of incline motor connect well. 2. If not, reconnect VR wire. Touch the incline motor by hand slightly. If it is hot, do not adjust the incline motor, or power off for about 5 minutes, power on again when the incline motor temperature returns to normal.

XIV. WARRANTY

AUSTRALIAN CONSUMER LAW

Many of our products come with a guarantee or warranty from the manufacturer. In addition, they come with guarantees that cannot be excluded under the Australian Consumer Law. You are entitled to a replacement or refund for a major failure and compensation for any other reasonably foreseeable loss or damage.

You are entitled to have the goods repaired or replaced if the goods fail to be of acceptable quality and the failure does not amount to a major failure. Full details of your consumer rights may be found at www.consumerlaw.gov.au.

Please visit our website to view our full warranty terms and conditions:
<http://www.lifespanfitness.com.au/warranty-repairs>

WARRANTY AND SUPPORT

Any claim against this warranty must be made through your original place of purchase. Proof of purchase is required before a warranty claim may be processed.

If you have purchased this product from the Official Lifespan Fitness website, please visit <https://lifespanfitness.com.au/warranty-form>

For support outside of warranty, if you wish to purchase replacement parts or request a repair or service, please visit <https://lifespanfitness.com.au/warranty-form> and fill in our Repair/Service Request Form or Parts Purchase Form.

Scan this QR code with your device to go to lifespanfitness.com.au/warranty-form



XV. HAND PULSE TECHNOLOGY

This product comes equipped with hand pulse sensors which are used to pick up tiny EKG/ECG signals that run through the body when your heart beats. These electrical EKG/ECG signals are very small and must be amplified 1000 times to make the signal viable for the computer to display your pulse.

To ensure proper operation:

- The user must maintain good, consistent contact on all four sensors.
- The users skin cannot be too dry or too wet.

Other factors that could affect the reading:

- Change of grip on the sensors (during slow pace walking and up to running).
- Tightening of hand muscles will produce small electrical signal.
- Static electricity charges from the air or from walking on the treadmill.

EKG/ECG Sensors may filter through actual EKG/ECG signals and "Noise" factors that may affect the reading. This will cause the pulse reading to be delayed and will take longer to update the display as the heart rate changes. Too much noise will create an incorrect reading. Medical conditions or having no electrical signal in the hands are other factors that may also affect pulse readings.

These are limitations of hand pulse technology and even the most expensive systems (which can cost upwards of \$3,000) used in hospitals have the same problems. The difference is that a patient in a hospital is not running on a treadmill. Hand pulse technologies work well on stationary exercise machines like bikes and even elliptical cross trainers but are not perfect on a treadmill. We offer treadmills with a wireless heart rate receiver which may be the more accurate option.

To test if your hand pulse sensors are working up to specification, hold them while standing on the sidestep rails, not walking, and see if the reading is more in line with what you would expect. This will eliminate the movement and static electricity factors. If your hands are dry, then wet them slightly (saliva works as a great conductor if this doesn't bother you).



WWW.LIFESPANFITNESS.COM.AU