

**DAF7003B**  
**AIR FRYER**



Believe in better



**Customer Care Line**  
(after sales service)

086 100 3339

**Small Appliance**  
Instruction manual

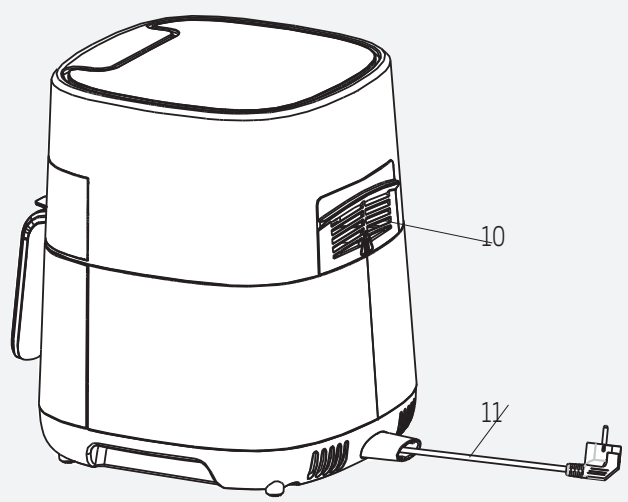
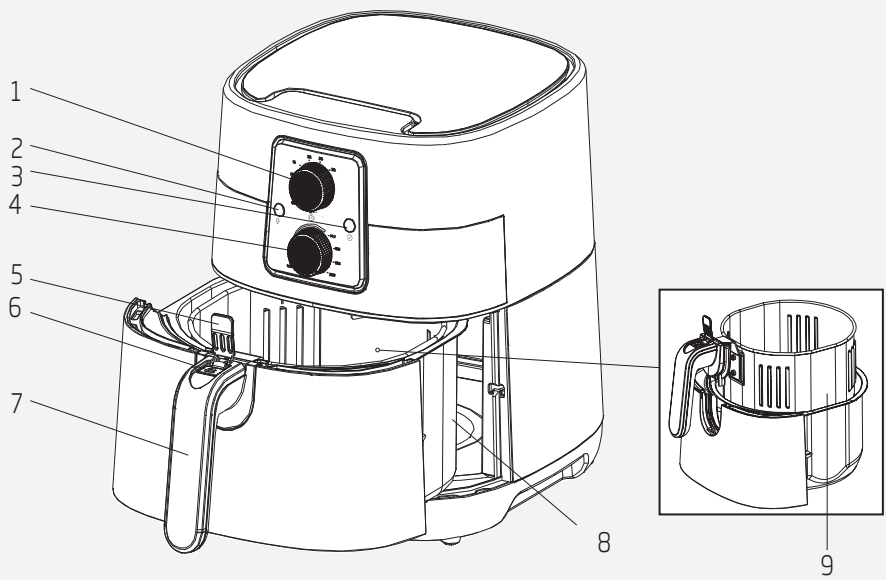

# Please read this user manual first!

Dear Customer,

Thank you for selecting an Defy product. We hope that you get the best results from your product which has been manufactured with high quality and state-of-the-art technology. Therefore, please read this entire user manual and all other accompanying documents carefully before using the product and keep it as a reference for future use. If you handover the product to someone else, give the user manual as well. Follow all warnings and information in the user manual.

## Meanings of the symbols

Following symbols are used in the various section of this manual:



Important information and useful hints about usage.



**WARNING:** Warnings for dangerous situations concerning the safety of life and property.



Materials are intended to be in contact with food.



Do not immerse the appliance, power cord or power plug in water or in other liquids.



Potection class against electric shock.



This product has been produced in environmentally-friendly, state-of-the-art facilities.

1. Timer button
2. Power indicator
3. Heat indicator
4. Temperature control button
5. Protection cover
6. Basket release button
7. Handle
8. Basket drawer
9. Removable basket
10. Air outlet
11. Power cord

## Technical data

**Power supply:** 220-240 V~, 50-60 Hz

**Power:** 1300 W

Technical and design modifications reserved.

The values which are declared in the markings affixed on your appliance or the other printed documents supplied with it represent the values which were obtained in the laboratories pursuant to the pertinent standards. These values may vary according to the usage of the appliance and ambient conditions.

# 1 Important safety and environmental instructions

This section contains safety instructions to prevent hazards that can result in injury or property damage.

Any warranty is void if these instructions are not followed.

## 1.1 General safety

- This appliance complies with international safety standards.
- This appliance is intended for home use and food preparation only, it is not suitable for professional use.
- This appliance is not intended for use by persons (including children) with reduced physical, sensory or mental capabilities or lack of experience and knowledge, unless they have been given supervision or instruction concerning the use of the appliance by a person responsible for their safety.
- Children should be supervised to ensure that they do not play with the appliance.
- Keep the product and the product cable out of the reach of children.
- Position the handles of the cooking appliances (if any) so that hot liquids do not spill and place them securely.
- Make sure that the voltage indicated on the appliance is the same as the mains voltage in your home.
- Use the appliance in a grounding plug.
- Do not use the appliance with an extension cord.
- Do not place your appliance on or near heat sources such as ovens and stoves.
- To prevent damage to the power cord, prevent it from being pinched, crimped or rubbed against sharp edges.
- Do not unplug the appliance by pulling on the cord.
- Do not immerse the appliance or its power cord in water.
- Do not leave the appliance unattended while it is plugged in.
- Do not disassemble the appliance.
- Use only original parts or parts recommended by the manufacturer.
- Unplug the appliance before cleaning and dry all parts completely after cleaning.

# 1 Important safety and environmental instructions

- Clean the appliance in accordance with the instructions in the Cleaning and Maintenance section.
- Do not put large pieces of food in the appliance as it may cause a fire.
- Do not touch the plug of the appliance while your hands are damp or wet.
- Do not use the appliance in humid environments.
- Do not move the appliance while it is in use and the oil inside is hot.
- Do not use the appliance in or near explosive or flammable environments and substances.
- To avoid the risk of burns, do not touch hot surfaces.
- Let the appliance cool down in a safe place out of the reach of children.
- Do not block the air inlet and air outlet openings while the appliance is operating.
- Do not lean over while the appliance is in use. Hot air rises from the appliance during use!
- The appliance becomes hot during use. To avoid the risk of burns, do not touch hot surfaces.
- Make sure that the room is adequately ventilated during use.
- In case of fire, unplug the appliance.
- Do not pour water on the appliance, as it may cause electric shock hazard.
- Do not operate the appliance with an external timer or a separate remote control system.
- The oil level must be between the specified maximum and minimum levels.
- Only use metal kitchenware with insulated handles with the appliance.
- Do not put anything on the appliance while it is operating or hot.
- To disconnect, turn the timer dial and temperature dial to the off position. Then unplug the appliance.
- If you keep the packaging materials, keep them out of the reach of children.

# 1 Important safety and environmental instructions

## 1.2 Compliance with the WEEE Directive and Disposing of the Waste Product:

This product complies with EU WEEE Directive (2012/19/EU). This product bears a classification symbol for waste electrical and electronic equipment (WEEE).



This symbol indicates that this product shall not be disposed with other household wastes at the end of its service life. Used device must be returned to official collection point for recycling of electrical and electronic devices. To find these collection systems please contact to your local authorities or retailer where the product was purchased. Each household performs important role in recovering and recycling of old appliance. Appropriate disposal of used appliance helps prevent potential negative consequences for the environment and human health.

## 1.3 Compliance with RoHS Directive

The product you have purchased complies with EU RoHS Directive (2011/65/EU). It does not contain harmful and prohibited materials specified in the Directive.

## 1.4 Package information



Packaging materials of the product are manufactured from recyclable materials in accordance with our National Environment Regulations. Do not dispose of the packaging materials together with the domestic or other wastes. Take them to the packaging material collection points designated by the local authorities.

## 2 Use

### 2. Intended use

- The appliance is intended for home use only, it is not suitable for professional use.
- The appliance may emit some smoke when you use it for the first time. This is normal.

### 2.1 Preparing the appliance for use

- Use the appliance in an upright position on a stable, flat, clean, dry and non-slip surface.

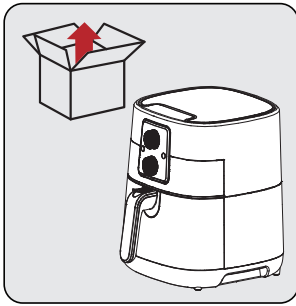

Before using the appliance for the first time, remove the packaging materials and place the appliance in a flat and clean area.

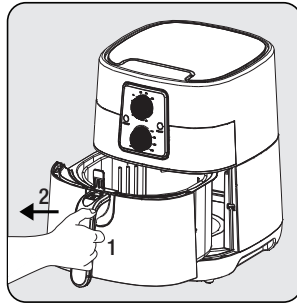

Firmly grasp the removable basket handle (7) to open the basket drawer; then remove the drawer from the machine.

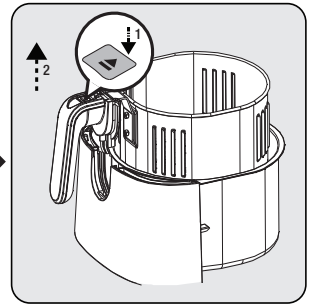

To release the basket from the drawer, place the drawer on a flat surface. Lift the protection cover (5), press the basket release button (6) and lift the basket out of the drawer.



Clean the basket drawer (8), removable basket (9) with warm soapy water and then dry the outer surface of the appliance and the parts you wash.

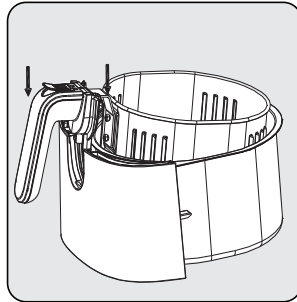

There are 2 notches on both sides of the handle. Lock the basket in the drawer by sliding the tabs into the notches on the top of the basket drawer.

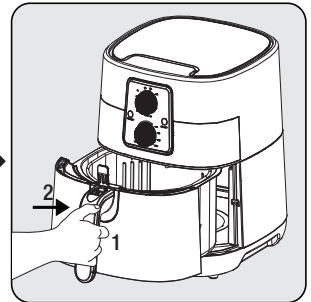

Attach the drawer to the appliance after cleaning all parts. Your appliance is ready for use.



Never use the basket drawer without a frying basket.



## 2 Use

### 2.2.1 Cooking

- Blend the food you are cooking with the oil before placing it in the cooking drawer.



**WARNING:** It is not suitable for recipes containing large amounts of liquid. Do not overfill the cooking pan and exceed the maximum food level.

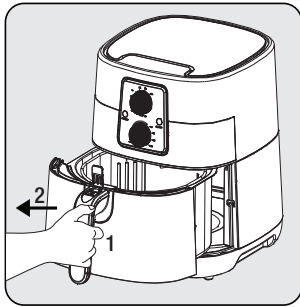

Firmly grasp the removable basket handle to open the basket drawer; then remove the drawer from the appliance and place it on a flat and clean surface.

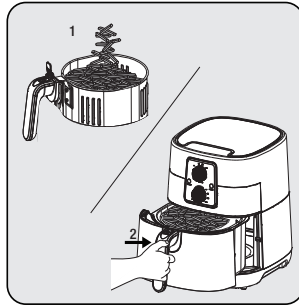

Place the food in the frying basket. Then attach the basket to the appliance and make sure it fits completely.

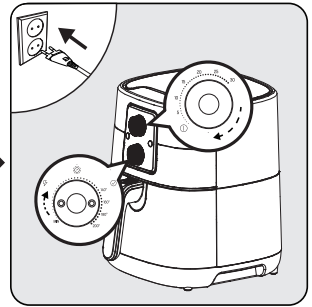

Plug your appliance in and set the timer and temperature control knob according to the type of food. The appliance starts cooking.



- If your appliance is cold, turn the timer knob (1) to +5 minutes for preheating. When the red power indicator (2) lights, your appliance will start to warm up.
- Your appliance will not heat up unless you set the timer dial.
- When your appliance reaches the set temperature, the green heat indicator (3) light will come on.
- To ensure that the cooking/frying process is uniform, remove and shake the basket drawer and check it, if necessary. If necessary, adjust the temperature.
- You can turn it off at any time by turning your appliance's timer knob to 0.



**WARNING:** When shaking food, make sure the basket is in the locked position. Do not press the basket release button (6) while mixing the frying basket.

## 2 Use

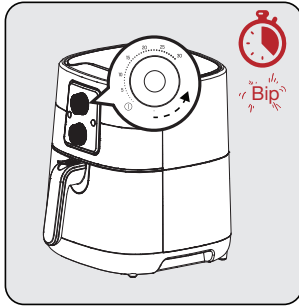

When the set frying time has expired, a warning tone will sound and your appliance will automatically shut down.

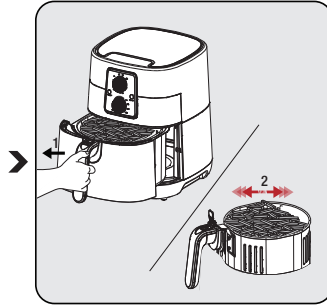

Remove the frying drawer and check the colour and state of food. If additional frying is required, you can increase the frying time a little longer.

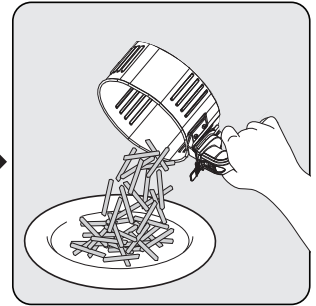

After the process is completed, pour the ingredients in the basket into a bowl or plate. Since hot or filtered oil can accumulate at the bottom of the pan, always remove the basket with ingredients from the pan before serving.



- Let it rest for 5 to 10 seconds before removing the food from the frying basket.
- Use tongs to remove large or soft foods from the basket.
- When a batch of food is ready, the product is instantly ready for another batch.
- If necessary, remove the inner container (9) from the appliance and use it. After removing the inner container from the appliance, place it on a trivet.

### WARNING



- The amount of food should not exceed the maximum limit.
- Note that the appliance may be very hot during the removal.
- When frying is complete, turn both the temperature control dial and the timer dial to MIN and 0 (OFF).



The “⌚” icon on your appliance refers to the continuous time function, when you want to turn off your appliance, turn the timer switch to the off position.

### 3 Recipes

FOOD	AMOUNT AND SHAPE	TEMPERATURE	TIME (MIN)	SHAKE
FINGER SAUSAGE	500 g, cut into three with flower shape	180 °C	10	
MEATBALL	40 g, 6 pcs, long pressed by hand	180 °C	10	
FRIED EGG	3 eggs	180 °C - without basket	12	
BREAD	3 slices of whole wheat with sour-dough and walnut	180 °C	8	
CHICKEN WITH VEG-ETABLES	Chicken thighs cooked with vegetables	180 °C - using oven bag - without basket	60	
ORANGE CAKE	1 + 1/4 cup flour with chocolate chip and orange cake mortar	160 °C and then 140 °C - using greaseproof paper - with basket	160 °C for 20 minutes and 140 °C for 40 minutes	
FILLET STEAK	150 g, chopped cubed	200 °C - with basket	15	Once in the 8th minute
CARROT	2 pieces of medium size, cut into thick round slices	200 °C	35	Once in the 15th and 30th minutes
MUSHROOM	100 g, whole mushroom	200 °C - without basket	15	1 time in 8 minutes
TART - QUICHE	In muffin molds	180 °C - with basket	20	15th minute by lifting weights on it
POTATO CHIPS	Round slices from 1/4 potato, 50 g,	160 °C - with basket	15	1 time in 5 minutes
POTATO CROQUETTES	9 ready frozen croquettes	180 °C - with basket	20	
CRISPY CHICKPEA	100 g, chickpeas pre-pressed in water and boiled for 10 minutes	180 °C - with basket	30	Once every 15 minutes

# 3

## Cleaning and maintenance

### 3.1 Cleaning



Never use gasoline, solvent, abrasive cleaners, metal objects or hard brushes to clean the appliance.

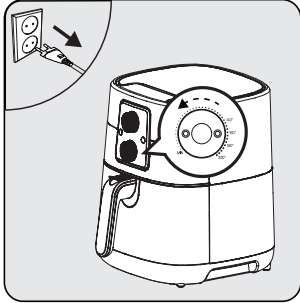

Turn the appliance off and unplug it.

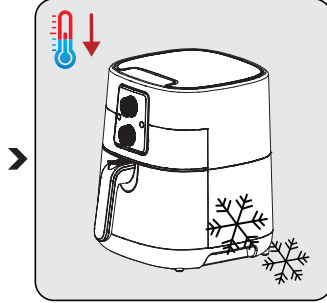

Let the appliance cool down completely.

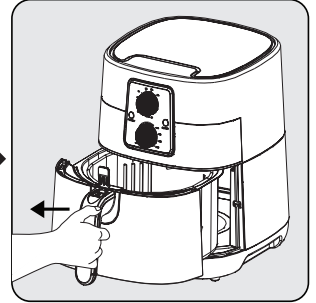

Remove the frying basket from the drawer.



Remove the pan and basket for your appliance to cool faster

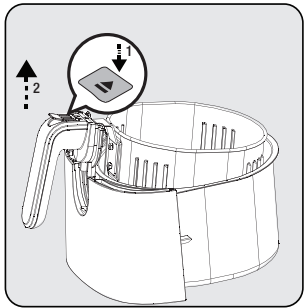

Press the basket release button (6) and remove the removable basket (9) by lifting and pulling the handle (8) upwards.

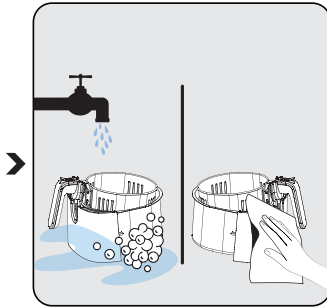

Clean the removable basket (9) and basket drawer (8) with warm soapy water and then dry them completely.

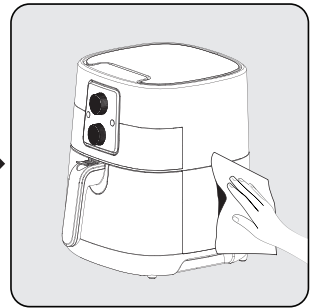

Use a damp cloth to clean the outer surface of the appliance. Dry the outside of the appliance completely.



Always keep the bottom of frying basket and drawer clean to prevent foreign material from accumulating.

## **3** Cleaning and maintenance

### **3.2 Storage**

- If you do not intend to use the appliance for a long time, store it carefully.
- Unplug the appliance and allow it to cool before storing it.
- Store the appliance in a cool dry place.
- Store the appliance and its cord out of the reach of children.

### **3.3 Transport and shipping**

- During transport and shipping, carry the appliance with its original packaging. The packaging of the appliance will protect the appliance against physical damage.
- Do not put heavy objects on the appliance or its packaging. Otherwise the appliance may be damaged.
- If the appliance is dropped, the appliance may not operate or permanent damage may occur.

## Branches

If you have followed the instructions and still have a problem, contact the customer care line on 086 100 3339. They will be able to advise you on any aspect of the appliance.

---

### South African Branches:

#### **BLOEMFONTEIN**

Unit Number 5  
Monument Business Park  
50 Monument Road  
Oranjesig, Bloemfontein  
[Bloemfontein.Service@defy.co.za](mailto:Bloemfontein.Service@defy.co.za)

#### **CAPE TOWN**

5A Marconi Rd. Montague Gardens, 7441  
[CapeTown.Service@defy.co.za](mailto:CapeTown.Service@defy.co.za)

#### **DURBAN**

135 Teakwood Road, Jacobs,  
Durban, 4052  
[Durban.Service@defy.co.za](mailto:Durban.Service@defy.co.za)

#### **EAST LONDON**

Robbie de Lange Road, Wilsonia,  
East London, 5201  
[EastLondon.Service@defy.co.za](mailto:EastLondon.Service@defy.co.za)

#### **GAUTENG, MIDRAND**

127 15th Road, Cnr Pharmaceutical & 15th Rd,  
Midrand, Gauteng  
[Gauteng.Service@defy.co.za](mailto:Gauteng.Service@defy.co.za)

#### **POLOKWANE**

87 Nelson Mandela Drive, Superbia 0699  
[Polokwane.Service@defy.co.za](mailto:Polokwane.Service@defy.co.za)

#### **PORT ELIZABETH**

112 Patterson Road, North End, Port Elizabeth  
6001  
[PortElizabeth.Service@defy.co.za](mailto:PortElizabeth.Service@defy.co.za)

### Sub-Saharan Africa Branches:

#### **ZAMBIA: SOUTHGATE INVESTMENTS LTD**

Plot 1606, Sheki Sheki Road  
P.O. Box 33681  
Lusaka, 10101, Zambia  
Tel: +260 0211 242332/3  
Fax: +260 0211 242933  
[sgiservicecentre@microlink.zm](mailto:sgiservicecentre@microlink.zm)

#### **NAMIBIA: ATLANTIC DISTRIBUTORS (PTY) LTD**

10 Tienie Louw Street, Northern Industrial Area  
P.O. Box 21158, Windhoek, Namibia  
Tel: (061) 216162  
Fax: (061) 216134  
[atlantic@mwweb.com.na](mailto:atlantic@mwweb.com.na)

#### **ZIMBABWE: TRADECOMAFRICA**

Trade Com Africa, 183 Loreley Crescent  
Msasa, Harare, Zimbabwe  
Tel: +263 4 486165/6  
Cell: +263 772 469010  
Cell: +263 772 469011

#### **BOTSWANA: RAY MORGAN AGENCIES**

RMA Service Centre, Plot 48, East Gate  
Gaborone International Commerce Park  
Kgale View, Gaborone  
Botswana  
Tel: +267 390 3996 / 390 3912  
Fax: +267 318 7376  
Cell: +267 7134 6539  
[service@rma.co.bw](mailto:service@rma.co.bw); [raja@rma.co.bw](mailto:raja@rma.co.bw)

#### **SWAZILAND: LYNDS DISTRIBUTORS**

P.O Box 716, Mbabane, Swaziland, H100  
Tel: (00268) 2515 4310/8  
Fax: (00268) 2518 4318

#### **MOZAMBIQUE: COOL WORLD. LDA**

Rua da Resistencia No. 97B R/C  
Cell: +258 84 44 61 234  
[coolworldlda@hotmail.com](mailto:coolworldlda@hotmail.com)  
Nosso Show Room  
Av: da Industrias, Parcela No.735 \* 735A  
Machava, Maputo

## Warranty

---

This certificate is issued by DEFY APPLIANCES (PTY) LIMITED manufacturers of Defy and Ocean products, hereinafter the Company, to the original purchaser only, of the appliance described on the certificate and shall constitute the only warranty given in respect of this appliance.

The Company warrants to the original purchaser that for a period of ONE YEAR from date of purchase the appliance is free from defect under normal domestic use, both in workmanship and material, subject to the following conditions.

1. Carry-in service. Small appliances are repaired in our service centres and are not collected from the customers home. Faulty units must be delivered to the purchasing dealer or to the nearest Company Service Centre for warranty repairs.
2. Vitreous enamelware, fuses and lamps are specifically excluded from these warranties. It is an express condition of these warranties that the purchaser takes due care and attention in the use and maintenance of the appliance. Abuse, misuse in conflict with operating instructions, connection to incorrect voltages and subjection to commercial use shall release the Company from its obligations.
3. This warranty shall become void and cease to operate if the appliance is dismantled by, or any repairs to the appliance are effected by any persons not duly authorised by the Company, or if substitute parts not approved by the Company are used in the appliance, or if the serial number of the appliance is removed.
4. The Company shall not be responsible for damages resulting from fire, flood, civil disturbances or any Act of God. The Company shall not, in terms of these warranties be responsible nor held liable for any consequential loss or damage of any kind caused by or due to the failure or malfunction of the appliance. The Company shall not be responsible for damages caused by insect and/or animal infestation.
5. The Company shall not be responsible for transportation or other costs other than those incurred within the provisions of Point 1 of this Certificate.
6. **For warranties in the Republic of South Africa and Sub-Saharan Africa, please contact the customer care line. Please refer to the previous page for respective South African branches and Sub-Saharan Africa branches.**
7. Where service is requested under warranty and no fault or defect can be found by the Company, all costs incurred will be for the purchaser's account.
8. This Certificate as well as your invoice will serve as proof of purchase. For the purpose of warranty, it will be essential to produce this Certificate and invoice. Failure to do so, will render the purchaser liable for service costs.

**KEEP THIS CERTIFICATE AND SALES INVOICE AS PROOF OF  
PURCHASE FOR WARRANTY PURPOSES.**