

**Features**

- Premium car audio processor
- Hi-res 192 kHz processing
- 6 x analog + 2 x digital inputs
- 12 x analog outputs

**Hardware**

- 400 MHz Floating Point DSP
- 32-bit audiophile converters

**External control**

- Wired external remote for volume control and preset recall
- I.R. remote for volume control and preset recall

**Software Control**

- USB 2.0 interface
- Plug & Play, Windows & Mac
- Easy SD card firmware upgrade

**Power**

- Isolated 12 VDC supply
- Remote IN/OUT with delay

**Applications**

- Mobile Audio DSP processor
- Battery powered systems
- Advanced system tuning

The C-DSP 8x12 v2.0 is miniDSP's next-generation processor for high-end mobile/car audio. The powerful 400 MHz SHARC floating-point processor provides pristine high-resolution audio at internal sample rates up to 192 kHz. With a wealth of inputs and outputs in a compact, rugged enclosure, the C-DSP 8x12 is suitable for installations from simple stereo, through surround systems with subwoofer integration, up to advanced multichannel active systems. New to this upgraded version are the onboard 32bit AKM converters that provide low noise and improved dynamic range to perfect your system.

The driverless USB interface is used to configure miniDSP's powerful but easy-to-use audio processing: parametric EQ on all inputs and outputs, compressors and adjustable time delay on all outputs, crossovers up to 48 dB/octave, and an advanced matrix mixer. Four complete processing configurations are stored in flash memory for instant recall with a wired or infrared remote.

Hardware features dedicated to the vehicle environment include an on-board isolated power supply, remote trigger input/output, a wired remote for dash or console mounting, dedicated Rear/Center processing and a microSD card slot for offline configuration and firmware updates.



**TYPICAL APPLICATION / SCREENSHOTS**

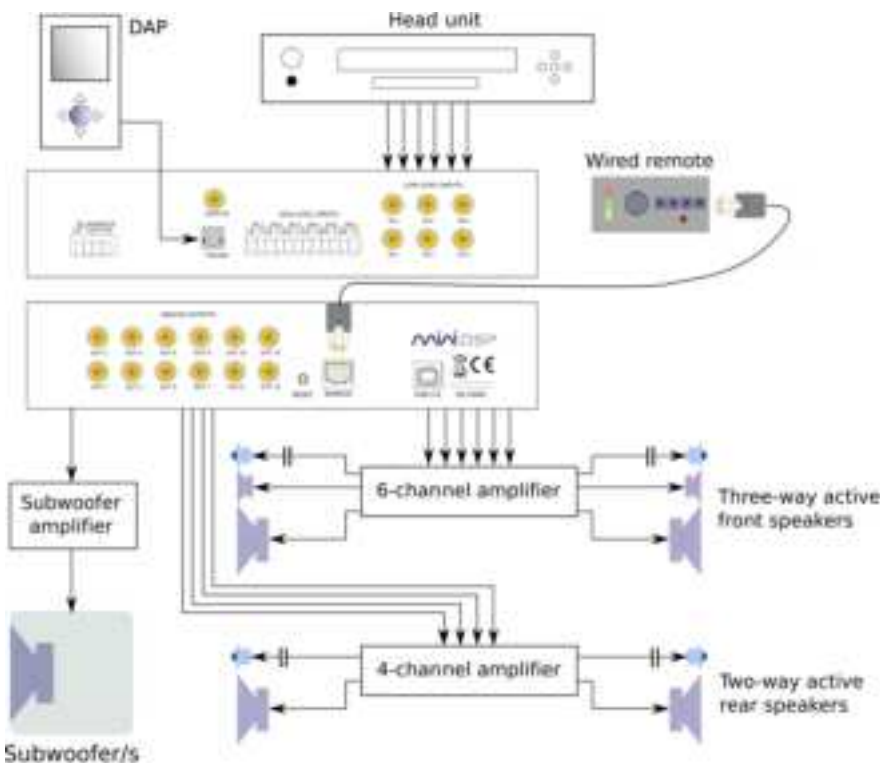

Advanced Matrix Mixer for Rear Fill/Center effect

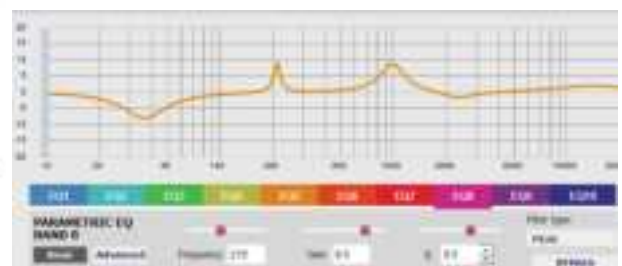

**HARDWARE SPECIFICATIONS**

Item	Description
Digital Signal Processor	400 MHz, 32-bit floating-point SHARC Digital Signal Processor (ADSP21489)
ADC/DAC Resolution	24-bit, up to 192 kHz native - check plugin for details
Control	Driverless USB 2.0 control interface for control from Windows or Mac
Digital audio inputs	Software selectable SPDIF (RCA) or TOSLINK (Optical) / 44.1-192 kHz
Analog audio inputs	6 x high-level differential inputs (terminal block) . Selectable max level: 8 or 12Vrms / Zin: 68 Ω 6 x low-level differential inputs (on RCA) . Selectable max level via DIP switches: 2 or 4Vrms Zin: 10 kΩ (at 4V rms setting)
Analog audio outputs	12 x outputs on RCA connector with anti-pop mute circuit . Max output signal 4.5 V rms @ 0 dB FS / Zout = 560Ω . Measured THD+N 0.0007%, 115dB SNR
DSP processing	Full suite of miniDSP processing (see the User Manual for specific plugins)
Wired external remote	External wired remote (RJ11 cable for power and data) selects active preset, master volume and master mute; LED indication of master volume and active preset.
microSD Card	Allows setup and firmware upgrade of the unit offline without a laptop.
Power supply / REM in&out	Isolated DC-DC conversion / 10-14 V DC compliant REM in (4 V DC trigger level) REM out / 12 V DC @ 100mA max current out Remote modes (1: Disabled 2: REM in trigger)
Dimensions (W x D x H)	41 x 205 x 122 mm
Enclosure	Powder-coated steel with removable brackets

**MECHANICAL SPECIFICATIONS**

