

**SIEMENS**



# SINAMICS S120 Cabinet Modules

North American Edition

SINAMICS Drives

Catalog  
D 21.7

Part 1  
2013

Answers for industry.

## Related Catalogs

**SINAMICS S120** D21.3 • 2011  
Chassis Units and Cabinet Modules (IEC)  
**SINAMICS S150**  
Drive Converter Cabinet Units (IEC)  
E86060-K5521-A131-A3-7600  
**DRCA-21300-0412**



**SIMOTION, SINAMICS S120 and Motors for Production Machines**  
Catalog PM 21 • 2011  
E86060-K4921-A101-A2-7600  
**DRCA-K4921-0111**



**SINAMICS G150 NEMA Enclosed Drives** D11.7.1 • 2013  
**DRCA-D1171-0313**



**SINAMICS G130 Drive Converter Chassis Units** D11 • 2011  
**SINAMICS G150 Drive Converter Cabinet Units (IEC)**  
E86050-K5511-A101-A5-7600  
**DRCA-D1100-0412**



**SINAMICS and Motors for Single-Axis Drives** D31 • 2012  
E86050-K5531-A101-A1-7600  
**DRCA-D3112-0412**



**Low Voltage AC Motors** D81.2 • 2012  
Selection and Pricing Guide, USA Edition  
**NMPC-00600-0212**



**SIMOTICS Low-Voltage Motors (IEC)** D81.1 • 2012  
Frame sizes 63 to 450  
Power range 0.09 to 1250 kW  
E86060-K5581-A111-A4-7600



**SINAMICS GM150, SINAMICS SM150 Medium Voltage Converters** D12 • 2012  
E86060-K5512-A101-A3-7600



## The Engineering Manual

### SINAMICS Low Voltage Engineering Manual

Engineering Manual for SINAMICS G130 Drive Chassis, SINAMICS G150 Enclosed Drives, SINAMICS S120 Drive Chassis, SINAMICS S120 Cabinet Modules, SINAMICS S150 Enclosed Drives

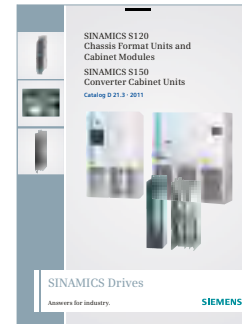

The engineering manual is divided into the following chapters:

- Fundamental Principles and System Description
- EMC Installation Guideline
- General Engineering Information for SINAMICS
- SINAMICS G130 Converter Chassis Units
- SINAMICS G150 Converter Cabinet Units
- SINAMICS S120 Chassis Format Units and Cabinet Modules
- SINAMICS S150 Converter Cabinet Units
- Drive Dimensioning
- Motors

This manual offers users comprehensive support for the configuring of drives and associated system components.

The first three chapters are devoted primarily to the fundamental physical principles of variable speed electric drives and include EMC Installation Guidelines as well as general system descriptions and planning information which relate to all products in the SINAMICS range. The other chapters then discuss in detail questions relating to the dimensioning of specific drive models as well as the selection of suitable motors.

#### Note:

**The engineering manual is not available as a printed hard copy, but only as an electronic file in PDF format.**

# SINAMICS Drives

## SINAMICS S120 Cabinet Modules

### North American Edition

Catalog D21.7 (part 1) • 2013



### Quality

The products and systems described in this catalog are produced/distributed in accordance with the requirements of a quality management system which has been certified to ISO 9001:2008.

© Siemens AG 2013

<b>Introduction</b> The SINAMICS drives family	<b>1</b>
<b>SINAMICS S120 Cabinet Modules system overview</b> NEMA/UL and IEC versions UL listing of a Cabinet Module line-up System configuration guidelines	<b>2</b>
<b>Line Modules</b> Line Connection Modules Basic Line Modules Smart Line Modules Active Line Modules	<b>3</b>
<b>Motor Modules</b> Motor Modules chassis format Motor Modules booksize format Braking Modules (chassis mounted) Braking Modules (motor modules)	<b>4</b>
<b>Auxiliary Modules, Options</b> Auxiliary Power Supply Modules Custom Cabinet Modules Integration Engineering Description of Options	<b>5</b>
<b>Engineering Information</b> Technical Data Characteristic curves (derating, overloads) Control units and interfaces Sensor and I/O modules Connection system – Signal Cables Safety Integrated	<b>6</b>
<b>Engineering Tools, Services &amp; Support</b> Engineering Software Service & Support	<b>7</b>

# SINAMICS Drives

One Family, One Source, All Applications

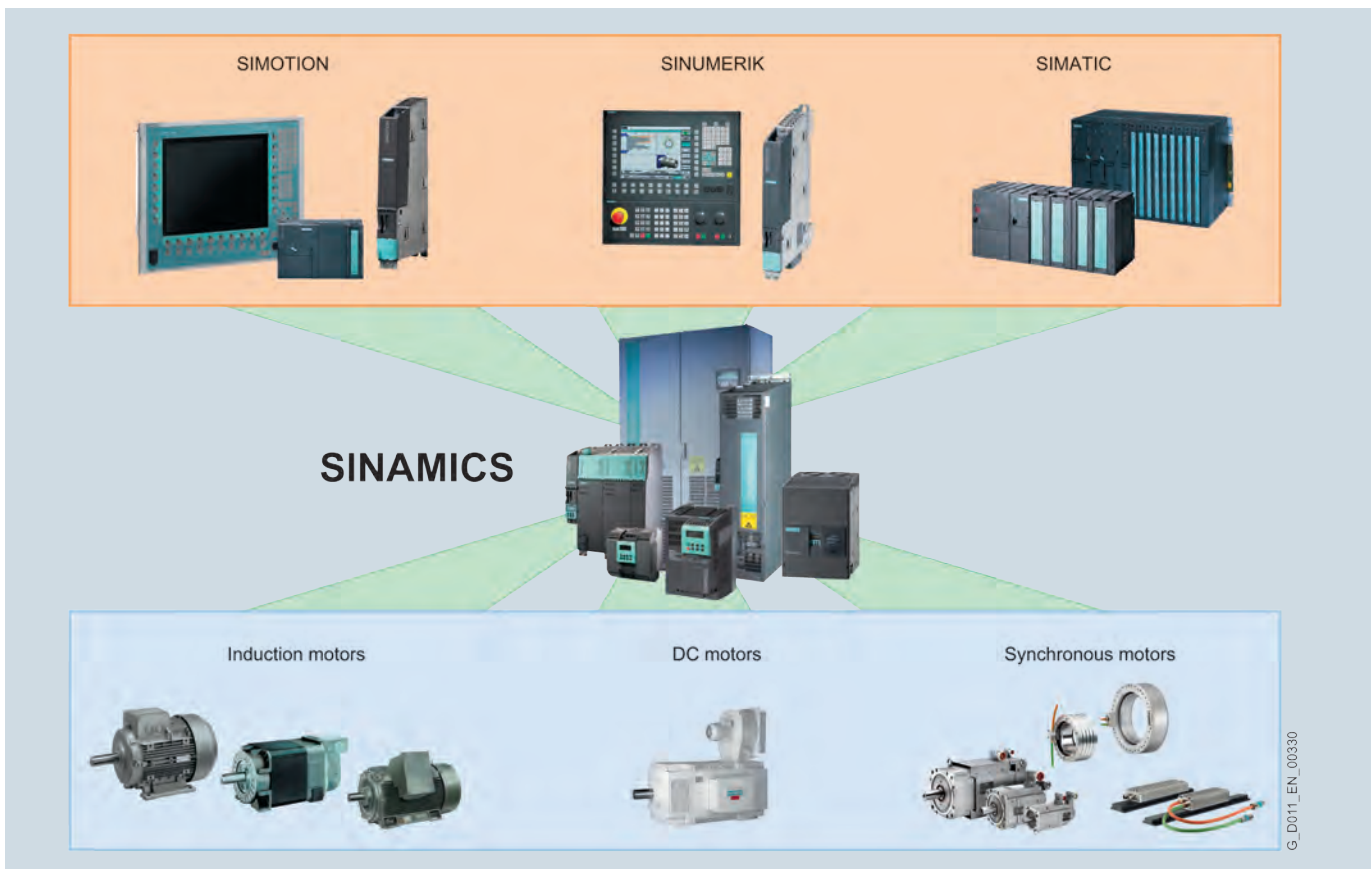

## Application

SINAMICS is the family of drives from Siemens designed for industrial applications that offers solutions for all drive tasks:

- Basic pump and fan applications in the process industry.
- Complex single-motor drives in centrifuges, presses, extruders, elevators, as well as conveyor and transport systems
- Coordinated drive line-ups for textile, plastic film, and paper machines, as well as for rolling mills
- High precision servo drives for machining
- Highly dynamic servo drives for machine tools, as well as packaging and printing machines

## Product variants

The SINAMICS range offers the ideal variant for all drive tasks:

- SINAMICS G is designed for standard applications, mostly with induction motors, that have less stringent requirements on the dynamic performance.
- SINAMICS S handles complex drive tasks with synchronous or induction motors and fulfills the most stringent requirements regarding
  - the dynamic performance and control accuracy
  - integration of extensive technological functions in the drive control system.
- SINAMICS DCM is the DC drive in the SINAMICS family. It can be configured to address both basic as well as demanding drive applications.

## Platform concept and Totally Integrated Automation

All SINAMICS versions are based on a platform concept. Common hardware and software components, as well as standardized tools for design, configuration, and commissioning tasks ensure high-level integration across all components. SINAMICS covers the full range of drive applications. The different SINAMICS versions can be easily combined with each other.

SINAMICS is part of the Siemens "Totally Integrated Automation" concept. Integrated SINAMICS systems covering engineering, data management and communication at the automation level, result in extremely cost effective solutions based on SIMOTION (motion control), SINUMERIK (machine tool) and SIMATIC (PLC and DCS) control systems.

## Quality management to ISO 9001

SINAMICS meets the highest quality requirements. Comprehensive quality assurance measures in all development, engineering and production processes ensure a consistently high level of quality.

Of course, our quality management systems are certified by independent authorities in accordance with ISO 9001.

# SINAMICS S120 Cabinet Modules Introduction

# 1



1/2

## **The members of the SINAMICS drives family**

SINAMICS low voltage drives

SINAMICS DC drives

SINAMICS medium voltage drives

The SINAMICS S120 range

# SINAMICS S120 Cabinet Modules

1

## Introduction

### The SINAMICS drives family

#### SINAMICS low voltage drives

##### SINAMICS G110



The versatile single motor drive for low power ratings

##### SINAMICS G120



The modular single motor drive for low up to medium power ratings

##### SINAMICS G110D



The distributed single motor drive for basic solutions

##### SINAMICS G120D



The distributed single motor drive for high performance

#### Typical ratings

230 V 1 ph. AC in / 3 ph. out  
0.15 to 4 HP  
(0.12 to 3 kW)

380 to 690 V 3 ph. AC  
0.15 to 400 HP  
(0.37 to 250 kW)

380 to 480 V 3 ph. AC  
1 to 10 HP  
(0.75 to 7.5 kW)

380 to 480 V 3 ph. AC  
1 to 10 HP  
(0.75 to 7.5 kW)

#### Main applications

Machine and plants for industrial and commercial applications

Machine and plants for industrial and commercial applications

Horizontal conveyor applications, main focus on distribution and logistics in airports; suitable for basic conveyor-related tasks with local control or connected to a bus via ASInterface

Conveyor applications in industrial environments, main focus on the automotive industry; also suitable for high-performance applications e.g. at airports and in the food, beverage and tobacco industry

#### Application examples

- Simple pumps and fans
- Auxiliary drives
- Conveyor systems
- Billboards
- Door/gate operating mechanisms

- Pumps
- Fans
- Compressors

- Conveyor systems
- Airports
- Distribution logistics

- Conveyor systems
- Electric monorail system in distribution Logistics

#### Highlights

- Compact
- Can be flexibly adapted to different applications
- Simple and fast commissioning
- Clear terminal layout
- Optimum interaction with SIMATIC and LOGO!

- Modular
- Can be flexibly expanded
- Safety Integrated
- Simple and fast commissioning
- Regenerative feedback
- Innovative cooling concept
- Optimum interaction with SIMOTION and SIMATIC

- Low profile design with standard footprint, IP65
- Easy, fast commissioning
- Optional key-operated disconnect switch
- AS-Interface with bus parameterization
- Quick stop function
- Integrated brake control
- Optimum interaction with SIMATIC and LOGO!

- Low profile design with standard footprint, IP65
- Modular
- Can be flexibly expanded
- Easy, fast commissioning
- Regenerative feedback
- Optimum interaction with SIMOTION and SIMATIC
- SINAMICS Safety Integrated

Catalog D31

Catalog D31

Catalog D31

Catalog D31

## The SINAMICS drives family



SINAMICS low voltage drives			
SINAMICS G120E	SINAMICS G130	SINAMICS G150	SINAMICS G150 NEMA
			
<i>The versatile enclosed drive for low to medium power ratings</i>	<i>The modular single motor drive solution for drives with a high power rating</i>	<i>The universal enclosed drive solution for drives with a high power rating</i>	<i>The universal high power enclosed drive solution per North American standards</i>
<b>Typical ratings</b>			
380 to 480 V 3 ph. AC 1 to 200 HP (0.75 to 132 kW)	380 to 690 V 3 ph. AC 100 to 800 HP (75 to 560 kW)	380 to 690 V 3 ph. AC 100 to 1,250 HP (75 to 2,700 kW)	380 to 600 V 3 ph. AC 150 to 800 HP (110 to 560 kW)
<b>Main applications</b>			
Standard and regenerative industrial applications in water, chemicals, oil and gas, packaging, paper, metals, minerals and others	Applications in the process and production industry, including power stations, oil and gas, petrochemicals, paper, cement, stone, metals	Applications in the process and production industry, including power stations, oil and gas, petrochemicals, paper, cement, stone, metals	Applications in the process and production industry, including power stations, oil and gas, petrochemicals, paper, cement, stone, metals
<b>Application examples</b>			
<ul style="list-style-type: none"> <li>• Pumps and fans</li> <li>• Compressors</li> <li>• Conveyors</li> <li>• Mixers</li> <li>• Kilns</li> </ul>	<ul style="list-style-type: none"> <li>• Pumps and fans</li> <li>• Compressors</li> <li>• Extruders and mixers</li> <li>• Crushers</li> <li>• Grinding mills</li> <li>• Kilns</li> <li>• Test stands</li> </ul>	<ul style="list-style-type: none"> <li>• Pumps and fans</li> <li>• Compressors</li> <li>• Extruders and mixers</li> <li>• Crushers</li> <li>• Grinding mills</li> <li>• Marine propulsion</li> <li>• Test stands</li> </ul>	<ul style="list-style-type: none"> <li>• Pumps and fans</li> <li>• Compressors</li> <li>• Extruders and mixers</li> <li>• Crushers</li> <li>• Grinding mills</li> <li>• Kilns</li> <li>• Test stands</li> </ul>
<b>Highlights</b>			
<ul style="list-style-type: none"> <li>• Ready to connect and run</li> <li>• Flexibility based on G120 modular components</li> <li>• Optional power regeneration</li> <li>• UL508C listed</li> <li>• Safety Integrated</li> <li>• Optimum interaction with SIMOTION and SIMATIC</li> </ul>	<ul style="list-style-type: none"> <li>• Modular components</li> <li>• Space-saving</li> <li>• Low noise</li> <li>• Easy, quick commissioning</li> <li>• Optimum interaction with SIMATIC</li> <li>• Safety Integrated</li> </ul>	<ul style="list-style-type: none"> <li>• Ready to connect and run enclosed drive per IEC standards</li> <li>• Broad power range</li> <li>• Space-saving</li> <li>• Low noise</li> <li>• Easy, quick commissioning</li> <li>• Optimum interaction with SIMATIC</li> <li>• Safety Integrated</li> </ul>	<ul style="list-style-type: none"> <li>• Ready to connect and run enclosed drive per NEMA/ANSI standards</li> <li>• Optional listing to UL508A</li> <li>• Low noise</li> <li>• Easy, quick commissioning</li> <li>• Safety Integrated</li> </ul>
–	Catalog D11	Catalog D11	Catalog D11.7 Part 1

# SINAMICS S120 Cabinet Modules

1





## Introduction

### The SINAMICS drives family

SINAMICS low voltage drives			SINAMICS DC drives
SINAMICS S110	SINAMICS S120	SINAMICS S150	SINAMICS DCM
			
<i>The basic positioning drive for single axis applications</i>	<i>The flexible, modular applied drive system for demanding drive tasks</i>	<i>The drive solution for demanding high power single motor drives</i>	<i>The scalable drive system for basic and demanding applications</i>
<b>Typical ratings</b>			
380 to 480 V 3 ph. AC 0.15 to 125 HP (0.12 to 90 kW)	380 to 690 V 3 ph. AC 0.15 to 5,000 HP (0.12 to 4,500 kW)	380 to 690 V 3 ph. AC 100 to 1,250 HP (75 to 1,200 kW)	85 to 950 V 3 ph. AC 5 to 24,000 HP (4 kW to 18 MW)
<b>Main applications</b>			
Machine and plants in the industrial environment, where machine axes should be quickly and precisely positioned in the simplest possible way.	High performance applications in all industries, including coordinated multi-motor drive systems and very high power single drives, motion control (positioning, synchronization).	High performance, fully regenerative standalone drive applications requiring clean power (low harmonics, controllable power factor)	Industrial applications in metals, plastics, printing, paper, cranes, mining, oil and gas, for new installations and retrofits.
<b>Application examples</b>			
<ul style="list-style-type: none"> <li>• Handling equipment</li> <li>• Assembly machines</li> <li>• Laboratory automation</li> <li>• Metalworking, ceramics, glass, woodworking, printing machines</li> <li>• Plastics processing machines</li> </ul>	<ul style="list-style-type: none"> <li>• Machine tools</li> <li>• Production machines:</li> <li>• Presses</li> <li>• Converting applications</li> <li>• Handling equipment</li> <li>• Paper machines</li> <li>• Rolling mills</li> <li>• Marine applications</li> </ul>	<ul style="list-style-type: none"> <li>• Test bays</li> <li>• Centrifuges</li> <li>• Elevators and cranes</li> <li>• Cross cutters and shears</li> <li>• Downhill conveyor belts</li> <li>• Presses</li> <li>• Cable winches</li> </ul>	<ul style="list-style-type: none"> <li>• Rolling mills</li> <li>• Cross cutters and shears</li> <li>• Wire-drawing machines</li> <li>• Extruders and kneaders</li> <li>• Presses</li> <li>• Elevators and cranes</li> <li>• Cableways and lifts</li> <li>• Mine hoists</li> </ul>
<b>Highlights</b>			
<ul style="list-style-type: none"> <li>• Scalable ratings, functionality, number of axes, performance</li> <li>• Easy commissioning, auto-configuration</li> <li>• Innovative system architecture</li> <li>• Wide range of motors</li> <li>• Optimum interaction with SIMOTION, SIMATIC and SINUMERIK</li> <li>• Safety Integrated</li> </ul>	<ul style="list-style-type: none"> <li>• Flexible and modular</li> <li>• Choice of rectifier types</li> <li>• Fully scalable - ratings, functionality, number of axes, performance</li> <li>• Auto-configuration</li> <li>• Wide range of motors</li> <li>• Optimum interaction with SIMOTION, SIMATIC and SINUMERIK</li> <li>• Safety Integrated</li> <li>• Air or liquid cooled</li> </ul>	<ul style="list-style-type: none"> <li>• Ready to connect and run</li> <li>• High control accuracy and dynamic response</li> <li>• Low harmonics, exceeding IEEE 519 requirements</li> <li>• Tolerant of line voltage fluctuations</li> <li>• Reactive power compensation option</li> <li>• Safety Integrated</li> </ul>	<ul style="list-style-type: none"> <li>• Choice of Control Units</li> <li>• Integrated field power supply</li> <li>• Free function blocks and Drive Control Chart</li> <li>• Expandable functionality using SINAMICS components</li> <li>• Single-phase connection possible</li> </ul>
Catalog D31	Catalogs PM21, D21.3, D21.7	Catalog D21.3	Catalog D23.1



## The SINAMICS drives family



SINAMICS medium voltage drives			
SINAMICS GM150	SINAMICS SM150	SINAMICS GL150	SINAMICS SL150
			
<i>The universal drive solution for single motor drives</i>	<i>The drive solution for demanding single and multi-motor drives</i>	<i>The drive solution for synchronous motors at high power ratings</i>	<i>The drive solution for low speed motors with the highest torques and overloads</i>
<b>Typical ratings</b>			
2.3 to 4.16 kV 3 ph. AC 1,200 to 11,500 HP (1 to 8.5 MW)	3.3 kV 3 ph. AC 5,000 to 24,000 HP (4 to 17.5 MW)	Up to 12 kV 3 ph. AC up to 100,000 HP (up to 75 MW)	1 to 4 kV 3 ph. AC 3,000 to 36,000 HP (2.2 to 27 MW)
<b>Main applications</b>			
General purpose applications in the process industries	High performance and multi motor applications in metals and mining	High power and high speed applications in the process industries, especially in oil and gas and petrochemicals	High power and low speed applications especially in the metals and mining sectors
<b>Application examples</b>			
<ul style="list-style-type: none"> <li>• Pumps and fans</li> <li>• Compressors</li> <li>• Extruders and mixers</li> <li>• Grinding mills</li> <li>• Marine drives</li> </ul>	<ul style="list-style-type: none"> <li>• Hot and cold rolling stands</li> <li>• Mine hoists</li> <li>• Test stand drives</li> <li>• Downhill and cross country conveyor belts</li> </ul>	<ul style="list-style-type: none"> <li>• Compressors</li> <li>• Pumps and fans</li> <li>• Extruders and kneaders</li> <li>• Marine drives</li> <li>• Blast furnace blowers</li> </ul>	<ul style="list-style-type: none"> <li>• Hot rolling mill roughing stands</li> <li>• Mine hoists</li> <li>• Ore and cement mills</li> <li>• Excavators</li> </ul>
<b>Highlights</b>			
<ul style="list-style-type: none"> <li>• Space-saving</li> <li>• Easy, quick commissioning</li> <li>• Ready to connect and run enclosed drive</li> <li>• Optimum interaction with SIMATIC</li> <li>• Air and liquid cooled versions</li> </ul>	<ul style="list-style-type: none"> <li>• Four quadrant (regenerative) operation as standard</li> <li>• High degree of efficiency and operation that reduces stress on the motor</li> <li>• High control accuracy and dynamic response</li> <li>• Almost no line harmonics</li> <li>• Reactive power compensation option</li> <li>• Easy, quick commissioning</li> <li>• Ready to connect and run enclosed drive</li> <li>• Optimum interaction with SIMATIC</li> <li>• Air and liquid cooled versions</li> </ul>	<ul style="list-style-type: none"> <li>• Compact design and high power density</li> <li>• Simple operator control and monitoring</li> <li>• Extremely rugged, reliable in operation and almost maintenance free</li> <li>• Two directions of rotation by reversing the rotating field</li> <li>• Can be seamlessly integrated into higher level automation systems</li> <li>• Air and liquid cooled versions</li> </ul>	<ul style="list-style-type: none"> <li>• Low output frequency for low speed motors</li> <li>• High short-time overload capability</li> <li>• Four-quadrant operation as standard</li> <li>• Extremely rugged, reliable in operation and almost maintenance free</li> <li>• High efficiency</li> <li>• Can be seamlessly integrated into higher level automation systems</li> <li>• Air and liquid cooled versions</li> </ul>
Catalog D12	Catalog D12	—	—

# SINAMICS S120 Cabinet Modules

1

## Introduction

### The SINAMICS S120 range

Drives for single axis applications		Drives for multi axis applications		
				
<b>Blocksize format</b>	<b>Chassis format</b>	<b>Booksize format</b>	<b>Chassis format</b>	<b>Cabinet Modules</b>
Catalog PM 21	Catalogs D21.3 and PM21	Catalog PM 21	Catalogs D21.3 and PM21	This Catalog and D21.3

SINAMICS S120 is the modular drive system with vector and servo control that is ideal for demanding drive tasks in plant and machine construction.

Multi-axis drive solutions with higher-level motion control can be implemented with the modular SINAMICS S120 system just the same as solutions for single-axis drives.

Covering a power range from 0.12 kW to 4500 kW and various control modules with a graduated range of functions, the modular SINAMICS S120 system can be used to simply and quickly create a precisely tailored drive configuration – for almost any demanding drive application.

On the SINAMICS S120, the drive intelligence is combined with closed-loop control functions into Control Units. These units are capable of controlling drives in the vector, servo and V/Hz modes. They also perform the speed and torque control

functions plus other intelligent drive functions for all axes. Using the available closed-loop control techniques, both synchronous as well as induction motors can be operated, and therefore the complete range of low-voltage motors from Siemens.

Integrated PROFIBUS DP and PROFINET interfaces are available. These interfaces ensure easy integration into complete automation solutions.

SINAMICS S120 Cabinet Modules are available in an enclosed version. Individual enclosed modules can be combined to form drive lineups with including the full range of SINAMICS S120 power ratings. Standardized interfaces enable the modules to be linked quickly to create a ready-to-connect drive solution for multi-motor applications.

### Benefits

SINAMICS S120 is characterized by the following properties:

- For high-performance single and multi-axis applications
- Versatile and flexible
- Wide range of power ratings
- Wide range of functions, including Safety Integrated
- Supports various cooling types (air/liquid-cooled)
- Supports various infeed concepts
- Can be simply integrated into higher-level automation and IT environments
- User-friendly engineering
- Ease of handling
- Simple installation
- Practical connection system

### Applications

SINAMICS S120 vector control is recommended for drive solutions with continuous material webs, for example, wire-drawing machines, film and paper machines, as well as for hoisting gear, centrifuges and test stand drives.

Servo control with SINAMICS S120 is employed for cyclic processes with both precise and highly dynamic closed-loop position control.

With SINAMICS S120, more performance is integrated into machines that are used in many sectors, such as:

- Packaging, Textile, Printing and paper machines
- Presses and punches
- Machines used in the woodworking, glass and ceramics industries
- Hoisting gear and cranes
- Handling and assembly systems
- Machine tools
- Rolling mill drives
- A broad range of test stand applications

# SINAMICS S120 Cabinet Modules System Overview

# 2



2/2	<b>Overview of SINAMICS S120 Cabinet Modules</b>
2/3	<b>SINAMICS S120 Cabinet Modules – A Global Product</b> SINAMICS S120 Cabinet Module designs to NEMA vs to IEC standards
2/4	<b>SINAMICS S120 Cabinet Modules – NEMA/UL version</b> Overview of voltage and power ratings
2/4	<b>UL listing of a SINAMICS S120 Cabinet Module line-up</b>
2/5	<b>System configuration guidelines</b> Selection and basic configuration of Cabinet Modules Arranging modules in a line-up Specifying the DC bus Transport sections Options applicable to the line-up Documentation and integration engineering
2/7	<b>System design considerations</b>
2/7	<b>Benefits</b>

# SINAMICS S120 Cabinet Modules

## System overview

2

### Overview of SINAMICS S120 Cabinet Modules



SINAMICS S120 Cabinet Modules is a modular system to configure enclosed drive line-ups with a central line infeed (rectifier) and common DC bus supplying power to multiple motor modules (inverters). SINAMICS S120 Cabinet Module line-ups are typically used for either multi motor drive systems such as for paper machines, rolling mills, certain test stands and cranes, or for very high HP single drives. This makes it an ideal supplement to SINAMICS G150 and SINAMICS S150 stand-alone enclosed drives.

SINAMICS S120 Cabinet Modules are based on the SINAMICS S120 range of components. Chassis format power modules for line and motor modules are housed in individual cabinets. Also available are booksize motor modules, with several booksize module kits mounted in a booksize base cabinet. As standard, a line-up comprises cabinet modules installed side-by-side in a row. Other configurations (for example, back-to-back) are available on request.

All drive components are arranged in a clear, compact layout in the individual Cabinet Modules. They offer great flexibility for the configuration of drive line-ups, and a comprehensive array of options allows the systems to be optimally adapted for specific project, site, environmental, application and performance requirements.

The main components of the system are:

- Line Connection Modules with line side components such as circuit breakers, fuses, and when required, contactors and line reactors.
- Line Modules for the following variations of line infeed:
  - Basic Line Modules for two-quadrant (nonregenerative) operation
  - Smart Line Modules for four-quadrant (fully regenerative) operation
  - Active Line Modules for four-quadrant (fully regenerative) clean power operation, with negligible line harmonics and unity or adjustable power factor.
- The following types of Motor Modules:
  - Chassis format (in individual cabinets)
  - Booksize kits (mounted in booksize base cabinets)
- Control units
- Auxiliary Power Supply Modules to supply accessories such as blowers and for AC and DC control power.
- Various methods of dynamic braking with external resistors are possible:
  - Braking units mounted inside chassis
  - Configuring motor modules as braking modules
  - Central braking modules

Standardized power and control interfaces facilitate easy configuration, installation and integration with the plant. Pre-manufactured connections are provided for interconnecting the DC bus and auxiliary power between cabinet modules. Communication between power modules and control units is done via DRIVE-CLiQ, the flexible backplane bus.

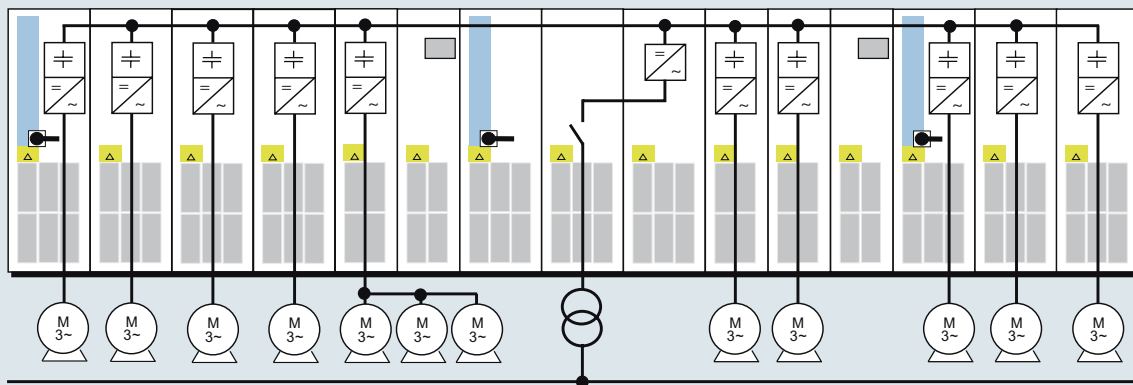

Example of a SINAMICS S120 Cabinet Module line-up for a multi motor drive system

### SINAMICS S120 Cabinet Modules – A Global Product

SINAMICS S120 Cabinet Modules (S120 CM) is a global product. However, regional differences in regulations, standards, specifications and voltage levels for power and control require modifications to the packaging (enclosure) and auxiliary components. SINAMICS S120 CM enclosed drive line-ups are therefore offered in versions designed to IEC (European) as well as to NEMA (North American) standards.

#### *SINAMICS S120 Cabinet Module designs to NEMA vs. to IEC standards*

All models of SINAMICS S120 CM (NEMA or IEC) use the identical basic drive and electronics components – power modules of a particular power and voltage rating, CU320-2 control units, CompactFlash cards with firmware, and optional modules of the SINAMICS S120 range (including for example, SMC30 encoder interface, VSM10 voltage

sensing module, CBE20 Ethernet communications module). Also, the cabinet dimensions and basic layouts are mostly the same for both versions.

Differences between the NEMA and IEC versions are found in the configuration of the base units, i.e. the enclosure version and the scope of auxiliary equipment included (specifically line side disconnects and short circuit protection), as well as the offered range of standard and custom options. Cabinet Modules to IEC and NEMA standards have different order numbers, to ensure consistency in the mechanical and electrical interfaces and documentation for a system to the respective standards.

Below is an overview of some of the more significant differences between NEMA and IEC versions (not a complete list!).

	<b>SINAMICS S120 CM NEMA version</b>	<b>SINAMICS S120 CM IEC version</b>
<b>Voltage ranges</b>	<ul style="list-style-type: none"> <li>Up to 600 V with UL listing (690 V without UL)</li> </ul>	<ul style="list-style-type: none"> <li>Up to 690 V</li> </ul>
<b>Base unit configuration</b>	<ul style="list-style-type: none"> <li>Circuit breaker disconnect per NEC/UL for motor branch circuit protection</li> <li>Use of UL listed or recognized components (including busbar and wiring)</li> <li>SCCR up to 100 kA per UL508A</li> <li>EMC filter Category C3 for 2nd environment (industrial) per IEC 61800-3</li> </ul>	<ul style="list-style-type: none"> <li>Disconnect and short circuit protection per IEC standards</li> <li>Components and wiring per IEC standards</li> <li>EMC filter Category C3 for 2nd environment (industrial) per IEC 61800-3</li> </ul>
<b>Enclosure options</b>	<ul style="list-style-type: none"> <li>Base: IP20 (no roof – air discharge upwards)</li> <li>NEMA 1 with raised roof (equivalent to IP21)</li> <li>NEMA 1 filtered with louvers and dust filters (equivalent to IP23) – min. required for UL listing</li> <li>IP43 as for IEC unit</li> <li>NEMA 12 (ventilated) – louvers and fine air filters (equivalent to IP54)</li> </ul>	<ul style="list-style-type: none"> <li>Base: IP20 (no roof – air discharge upwards)</li> <li>IP21 (with raised roof)</li> <li>IP23 (with top hat, louvers and dust filters)</li> <li>IP43 (like IP23, plus 1mm mesh screen)</li> <li>IP54 (like IP23, plus fine air filters)</li> </ul>
<b>Exclusive standard options</b>	<ul style="list-style-type: none"> <li>Only for NEMA version:</li> <li>UL/cUL listing of the complete line-up per UL508A</li> </ul>	<ul style="list-style-type: none"> <li>Only for IEC version:</li> <li>EMC filter Category C2 for 1st environment (residential) per IEC 61800-3</li> </ul>
<b>Types of dynamic braking units</b>	<ul style="list-style-type: none"> <li>Braking units mounted inside chassis</li> <li>Motor modules as central braking units (Central braking modules are not available with UL listing)</li> </ul>	<ul style="list-style-type: none"> <li>Braking units mounted inside chassis</li> <li>Motor modules as central braking units</li> <li>Central braking modules</li> </ul>
<b>Documentation languages</b>	<ul style="list-style-type: none"> <li>Standard English/Spanish</li> <li>Option English/French</li> </ul>	<ul style="list-style-type: none"> <li>Standard English/German</li> <li>Option English and either French, Spanish or Italian</li> </ul>

# SINAMICS S120 Cabinet Modules

## System overview

### SINAMICS S120 Cabinet Modules – NEMA/UL version

The following table provides an overview of the voltage ranges and power ratings of the SINAMICS S120 Cabinet Modules that are available for the NEMA/UL version:

Cabinet Module type	Input current	DC bus voltage	DC bus current	Output current	Power range <sup>1)</sup>	
					kW @ 460 V	HP @ 460 V
<b>Line voltage 380 ... 480 V 3 ph. AC</b>						
Line Connection Modules	250 ... 3,000 A	–	–	–	–	–
Basic Line Modules	365 ... 1,630 A	510 ... 650 V	420 ... 1,880 A	–	250 ... 1,000 kW	–
Smart Line Modules	463 ... 1,430 A	510 ... 650 V	550 ... 1,700 A	–	300 ... 900 kW	–
Active Line Modules	210 ... 1,405 A	540 ... 720 V	235 ... 1,574 A	–	150 ... 1,000 kW	–
Motor Modules Booksize	–	510 ... 720 V	11 ... 158 A	9 ... 132 A	4.8 ... 82 kW	5 ... 100 HP
Motor Modules Chassis	–	510 ... 720 V	252 ... 1,686 A	210 ... 1,405 A	125 ... 900 kW	150 ... 1,150 HP
<b>Line voltage 500 ... 600 V 3 ph. AC</b>						
Line Connection Modules	280 ... 3,000 A	–	–	–	–	–
Basic Line Modules	260 ... 1,580 A	675 ... 810 V	300 ... 1,880 A	–	200 ... 1,250 kW	–
Smart Line Modules	463 ... 1,430 A	675 ... 810 V	550 ... 1,700 A	–	400 ... 1,200 kW	–
Active Line Modules	210 ... 1,405 A	710 ... 900 V	644 ... 1,422 A	–	450 ... 1,150 kW	–
Motor Modules Booksize	–	–	–	–	–	–
Motor Modules Chassis	–	675 ... 900 V	102 ... 1,524 A	85 ... 1,270 A	70 ... 1,000 kW	100 ... 1,250 HP
<b>Line voltage 380 ... 600 V 3 ph. AC</b>						
Auxiliary Power Supply modules	125 ... 250 A	–	–	–	–	–

<sup>1)</sup> Higher power ratings can be achieved by connecting up to four identical line modules or motor modules in parallel.

#### Note regarding 690 V AC:

The components used in Cabinet Modules for a line voltage of 500 - 600 V are rated for 690 V per IEC standards (this includes the NEMA versions with an order number ending in "U3"). However, operation of these units at nominal line voltages >600 V (DC bus voltage >900V) invalidates their UL listing.

#### UL Listing of a SINAMICS S120 Cabinet Module line-up

SINAMICS S120 Cabinet Modules (NEMA version) can optionally be UL listed per UL508A, where the entire line-up is listed as one enclosed industrial control panel. UL listing of a line-up therefore requires all cabinet modules in the line-up to be compliant with UL508A.

Every cabinet module therefore needs to be specified with option code:

- U90 (UL listing per UL508A) or
- U91 (cUL listing per UL508A for Canada)

In addition, UL508A requires as a minimum a NEMA 1 enclosure, plus all ventilation openings to be fitted with air filters. Therefore, all cabinets need to be specified with option code:

- M23 (NEMA 1 filtered, IP23) as minimum

Also acceptable are options

- M43 (IP43) and
- M54 (NEMA 12 ventilated, IP54)

Furthermore, for the factory to apply a UL listing mark to the Cabinet Module line-up (being the enclosed industrial control panel per UL508A) it is a prerequisite that Integration Engineering be ordered for the line-up (refer to page 5/8).

This provides a comprehensive set of drawings and documentation for the line-up including all electrical and mechanical interconnections and wiring.

The short circuit current rating (SCCR) for the line-up is determined by all components including the line side components as well as Motor Modules. On the line side, the SCCR is determined by the Line Connection Module together with its associated Line Module(s). Refer to the Line Connection Module section (page 3/4) for SCCR. Some Line Connection Modules are available with a high SCCR of 84 kA or 100 kA, with option L70.

SCCR values apply only to the combination of Line Connection Module with the Basic, Smart or Active Line Module per the table "Assignment of Line Modules to Line Connection Modules" on page 3/5.

Auxiliary Power Supply Modules and options (braking units, output filters) are listed for an SCCR of up to 100 kA when included in a SINAMICS S120 Cabinet Module line-up.

The SCCR of the line-up is additionally dependent on the SCCR of the smallest Motor Module it contains. The maximum value of the SCCR is determined by the power rating of any Motor Modules as follows.

Motor Module(s) <600 HP:	Maximum SCCR 65 kA
Motor Module(s) <900 HP:	Maximum SCCR 84 kA

### System configuration guidelines

SINAMICS S120 Cabinet Modules is a modular system, where individual Cabinet Modules are combined into an enclosed drive line-up. The system provides a great deal of flexibility and together with a large variety of options allows an almost infinite number of possible permutations. To ensure that the end result is a fully functioning system in accordance with requirements, various aspects need to be considered in the selection and configuration of individual cabinet modules, and when specifying how these are to be combined into a line-up.

#### Selection and basic configuration of cabinet modules

- Motor Modules draw power from or generate power to the DC bus, and supply variable voltage and frequency to one or more motors. They are selected based on motor ratings and overloads, application specific duty cycles etc. Motor Modules are available in two formats:
  - Chassis format, with each chassis in its own cabinet.
  - Booksize format, where Booksize Base Cabinets contain a number of booksize module kits.
- Line Modules feed power to the DC bus. They are selected based on the power to be drawn from or regenerated into the supply system.
  - Basic Line Modules for motoring only.
  - Smart or Active Line Modules if power regeneration back to the line is necessary.
  - The overall power balance must be considered, for example, some motors may be motoring while others are regenerating. The energy would be exchanged on the DC bus and not necessarily back to the line, so the line module is often not sized to provide the sum of the motor module ratings. Only excess power is regenerated back to the line.
  - If the ratio of power regenerated to the line is small compared to the motoring power drawn from the line, special configurations such as a mix of Basic and Smart Line Modules may be appropriate. (Consult factory).
- Braking units for dynamic braking dissipate excess DC bus power in braking resistors. They may be needed:
  - Either as an alternative to regeneration to the line
  - Or, in some applications such as downhill conveyors, in addition to regeneration to allow electrical braking in the event of a power failure.
- Line Connection Modules connect Line Modules to the AC power supply, and contain at a minimum, the main circuit breaker disconnect and usually the semiconductor fuses as required for the short circuit current rating (SSCR) of the line-up. They are selected and configured to match the chosen Line Modules. This requires close attention to ensure that the correct AC bus interconnections and necessary components are provided.
  - Basic and Smart Line Modules generally require specific line reactors, active line modules do not.
  - Certain Line Modules (depending on type and rating) require a contactor or a main circuit breaker to bridge (bypass) the pre-charge circuit, and to switch the line module on line after completion of precharge.
- Auxiliary Power Supply Modules supply auxiliary and control power to the line-up, for example 3-phase and single phase AC power for the power module blowers,

contactor coils and motorized circuit breakers, and 24 VDC to power control units and other electronics. Auxiliary power terminal blocks are provided in each cabinet module, with a pre-manufactured cable looping auxiliary power from one cabinet module to the next.

- The Auxiliary Power Supply Module is selected based on the total power requirement of the line-up.
- For small line-ups, auxiliary power supplies can be provided in the Line Connection Module (options K70 or K76).
- It is also possible to provide auxiliary power from external sources. This is the default – auxiliary power will be provided internally only if specified!

#### Arranging Cabinet Modules in a line-up

After the Cabinet Modules are selected, they need to be arranged in a line-up, normally in a straight line next to each other. Such a line-up can be mounted against a wall (Cabinet Modules require front access only). Custom configurations (such as back-to-back) can also be offered. DC bus connections for back-to-back arrangements can be made at the end of a line-up or in the middle, in some instances without requiring any additional cabinet.

Various issues need to be considered when determining the layout of the line-up:

- A Line Module is always positioned adjacent to and on the right hand side of its associated single Line Connection Module (when looking at the front of the lineup). Line Connection Modules for parallel connection have the associated Line Modules on either side.
- Line Modules are often positioned towards the center of the line-up. This provides for half the total DC bus power to be fed in each direction (and therefore half the DC bus cross-section), in contrast to the DC bus having to carry full current if the Line Module is at one end of a line-up.
- The largest Motor Modules should preferably be closest to the Line Module. This may allow the DC bus size to be reduced further down the line-up where less power is required.
- Motor Modules that feed pairs of motors where one is motoring while the other is regenerating (e.g. winders/unwinders or some test stands) should preferably be positioned adjacent to each other, to minimize the DC bus current elsewhere in the line-up.
- Braking Modules should be positioned as close as possible to the motor module(s) regenerating the most power.
- For process, plant layout or cabling design reasons, there may be a preference to position certain drives in a sequence, or at least adjacent to each other in groups. Such preferences may need to be balanced against the considerations listed above, in order to obtain the best technical and most cost effective solution.

The positioning of Cabinet Modules in a line-up is therefore often an iterative process.

### System configuration guidelines

#### Specifying the DC bus for each Cabinet Module

Once the arrangement of Cabinet Modules is known, and with a thorough understanding of the DC current demand (motoring or generating) of the various Motor Modules based on the process to be controlled, the required DC bus current rating can be determined for each cabinet module.

- The DC bus rating is a mandatory option for all Line and Motor Modules.
- For Line Connection and Auxiliary Power Supply Modules a DC bus is optional. If these modules are positioned at the end of a line-up they may not need a DC bus. However, if there are Motor and/or Line Modules to either side, then a DC bus may be needed.
- The DC bus is available in different widths (60, 80 or 100 mm) and dependant on current rating with either a single busbar per pole, or two or three busbars in parallel.
  - Only busbars of the same width can be interconnected. Therefore all DC bus in a line-up must be of the same width.
  - For reduced DC bus current ratings along a line-up, it is possible to change from say three parallel busbars down to two, and then down to a single one.
- For the interconnection of the DC bus from one cabinet (or section of a line-up) to an adjacent one, standard bus transition pieces are provided. These are permanently mounted. During installation the transition pieces slide into the next bus section and only need to be tightened.

#### Combining Cabinet Modules into transport sections

Each Cabinet Module is specified individually. It is possible for each Cabinet Module to also be shipped individually, each one on its own pallet, each with its own piece of DC bus as specified per the option codes.

- It is important to note that even if Cabinet Modules are shipped individually, they need to be installed in the arrangement as per the specified line-up design. This is especially the case if the DC bus rating varies along the line-up. But there are usually also other components (such as DRIVE-CLiQ cables) that were selected based on a specific configuration.

It is, however, more common to combine Cabinet Modules into transport sections:

- Two or more Cabinet Modules are bolted together on a common pallet, and are fitted with a common transport beam. The maximum width of each transport section is 2,400 mm (approx. 8 ft). Transport sections are specified by option Y11, with a code to specify the position of a Cabinet Module within the line-up.
- Normally, the DC bus for each transport section is provided as a solid bus running its entire length.
  - This minimizes the number of bolted connections, simplifying installation and maintenance.
  - A consequence of this is that it is not possible to change the position of individual Cabinet Modules within a line-up at a later stage.
- Auxiliary power connections between cabinets in one transport section are automatically done in the factory.

#### Cabinet Module options applicable to a whole line-up

With each Cabinet Module being specified individually, it is necessary to ensure that they are all compatible and can be combined in one line-up. Examples of options applicable to all modules in a line up include:

- Enclosure type (NEMA 1, NEMA 1 filtered, NEMA 12).
- Cabinet base (plinth): All Cabinet Modules must have the same overall height.
- UL or cUL listing – the complete line-up is either UL listed per UL 508A or not. It is not possible to have only some of the Cabinet Modules UL listed, but others not.
- Documentation format and languages should be the same for all modules. Documentation options can be specified for each Cabinet Module individually, or for the line-up as a whole (refer to following paragraph).

#### Documentation and Integration Engineering

Included with each individual Cabinet Module is a set of drawings and documentation (in electronic format (pdf), shipped on a CD with the Cabinet Module). As a default there is, however, no documentation for the complete line-up showing interconnections between Cabinet Modules. The reason is that the factory cannot deduce how the various Cabinet Modules are intended to function, based on the individual part numbers. For example, there may be a number of Motor Modules with only some including a control unit, which could be connected in many different ways. One control unit could be used to control a number of power modules, each for a different motor or some power modules could be intended for parallel connection. And there is no way to tell which control unit is to be connected to which power module(s).

“Integration Engineering” to integrate the individual Cabinet Modules into one functioning line-up can be provided, based on a detailed customer specification. This includes:

- Documentation for the line-up as a whole, with all internal interconnections required for a functioning system.
- Provision of all the interconnections such as DRIVE-CLiQ cables and other wiring to achieve the specified functionality.

Integration Engineering can be ordered using separate part numbers. Documentation option codes (dxf format, advance (submittal) copies etc.) can be added to the order no. for integration engineering for the line-up as a whole, instead of being added to the order no. for each individual Cabinet Module.

Note that in this context “Integration Engineering” is limited only to integrating individual Cabinet Modules into a line-up. This is not to be confused with integration of the drive line-up into the customer’s plant and interconnection to external equipment such as power supplies, motors and process control or automation equipment, which is outside the scope of supply of a Cabinet Module line-up!



### System design considerations

SINAMICS S120 Cabinet Modules have been designed to offer the highest possible level of operational reliability.

- EMC measures have been rigorously implemented to ensure trouble free operation of high speed digital control and communication systems in close proximity to high power switching devices.
- With the help of air flow and temperature simulations, partitions have been designed to act as air baffles and heat sinks.
- Special measures used in the construction of the cabinets ensure that they remain mechanically durable over their entire life cycle.
- Attention has been paid to providing a wide range of cable routing options and special design concepts are applied consistently to broaden the scope of application and simplify servicing.
- The units are supplied complete with all the necessary connections and connecting elements. Thanks to their carefully considered configuration concept, cabinets are

shipped in a ready-to-connect state or, in the case of multiple transport sections, have been prepared for quick assembly.

The selection you make is supported by an extensive range of options, harmonized and coordinated to various applications.

The design of replaceable components is based on the principle that they must be quick and easy to change. In addition, the "Spares-On-Web" Internet tool makes it easy to view the spare parts that are available for the particular order.

All components, from individual parts to the ready-to-connect cabinet, undergo rigorous testing throughout the entire production process. This guarantees a high level of functional reliability during installation and commissioning, as well as operation.

### Benefits

The outstanding system features of the SINAMICS S120 Cabinet Modules provide the following advantages:

- Pre-designed, type tested system:
  - Configuration of standard catalog product minimizes engineering.
  - Type tested, robust design provides guaranteed performance in industrial environments.
- High level of reliability and availability:
  - Power modules with high ratings minimize component count and maximize reliability.
  - Individual modules and power components can be replaced quickly and easily, which ensures a higher level of plant availability.
- Process optimization with minimal effort:
  - A standard PROFIBUS or PROFINET interface and various analog and digital interfaces enable easy integration into automation solutions.
  - Vector control fulfills the most exacting requirements regarding the accuracy and dynamic response of drives.
- Energy savings during operation:
  - The inverters on the motor side are coupled through a common DC bus which allows energy exchange between motors that are motoring and generating. In this way, energy is saved, the line infeed is relieved and line harmonics reduced.
- Generally the line infeed is only dimensioned for the maximum energy or the maximum current drawn when motoring – and not the sum of the energy ratings of all Motor Modules connected to the DC bus.
- As a consequence, for example, for winders/unwinders or transmission test stands with Motor Modules that are motoring and generating, a significantly smaller line infeed unit can be selected.
- Cost minimization during operation, maintenance, and service:
  - Simple commissioning with the menu-driven STARTER commissioning tool.
  - Optional, menu-navigated AOP30 advanced operator panel with plain text display and bar-type display of process values.
  - All components are easily accessible, which makes them extremely service friendly.
- Space-saving design
  - Optimized component layouts result in smallest possible footprint.
- Environmentally friendly operation:
  - The drives are exceptionally quiet and compact due to the use of state-of-the-art IGBT power semiconductors and an innovative cooling concept that ensures a long lifetime.

# SINAMICS S120 Cabinet Modules

Notes

2



**3/2 Overview of Line Modules**  
Line Connection Modules  
Basic Line Modules  
Smart Line Modules  
Active Line Modules

**3/3 Line Connection Modules**  
Overview  
Design  
Selection and ordering data  
Block diagram  
Technical data  
Options

**3/13 Basic Line Modules**  
Overview  
Design  
Selection and ordering data  
Block diagram  
Technical data  
Options

**3/21 Smart Line Modules**  
Overview  
Design  
Selection and ordering data  
Block diagram  
Technical data  
Options

**3/29 Active Line Modules with  
Active Interface Modules**  
Overview  
Design  
Selection and ordering data  
Block diagram  
Technical data  
Options

## Line Module Overview

### Overview of Line Modules

Line Modules are the link between the 3-phase supply system and the common DC bus, and comprise:

- **Line Connection Module:** The Line Connection Module contains the disconnect device and short circuit protection (a circuit breaker plus fuses as required for SCCR), and when required additional components such as, for example, a contactor, line reactor and optionally AC and DC control power supplies. The Line Connection Module feeds 3-phase power to the line side converter – the Basic, Smart or Active Line Module.
- **Basic Line Module:** A Basic Line Module is a basic diode (or thyristor) 6-pulse bridge rectifier that rectifies the incoming AC power to feed the DC bus. A Basic Line Module is non-regenerative, meaning the power flow is always from the line supply system to the DC bus, it cannot feed power from the DC bus back into the line.

Up to four Basic Line Modules can be connected in parallel, or configured to provide 12-, 18- or 24-pulse rectifiers in combination with a phase shifting drive isolation transformer.

- **Smart Line Module:** A Smart Line Module is a fully regenerative IGBT bridge that is capable of feeding power in both directions, from the line to the DC bus, or from the DC bus back to the line, at 100% of its rated current. Unlike older designs using thyristor bridges to feed power back to the line, the Smart Line Module does not require an

autotransformer and there is no danger of inverter failure – the IGBTs will safely turn off in the event of a power failure during regeneration without damage or blowing any fuses.

Up to four Smart Line Modules can be connected in parallel, or configured to provide 12-, 18- or 24-pulse rectifiers in combination with a phase shifting drive isolation transformer.

For line-ups requiring only a small amount of regeneration compared to the power drawn from the supply for motoring, it is also possible to have a mix of Basic Line Modules and Smart Line Modules feeding a DC bus. This requires some engineering to ensure that each unit will carry the correct amount of current (please consult factory).

- **Active Line Module:** An Active Line Module is also a fully regenerative IGBT bridge that is capable of feeding power in both directions, but offers a number of unique features over and above a Smart Line Module. This includes very low harmonics (clean power), unity or adjustable power factor, and a controlled DC bus voltage that is held stable even with fluctuations in the supply voltage which provides a number of benefits explained elsewhere (refer to section on Active Line Modules). In the SINAMICS S120 Cabinet Module system, an Active Line Module is always supplied as a unit together with its Active Interface Module, which includes the clean power filter and pre-charge circuitry.

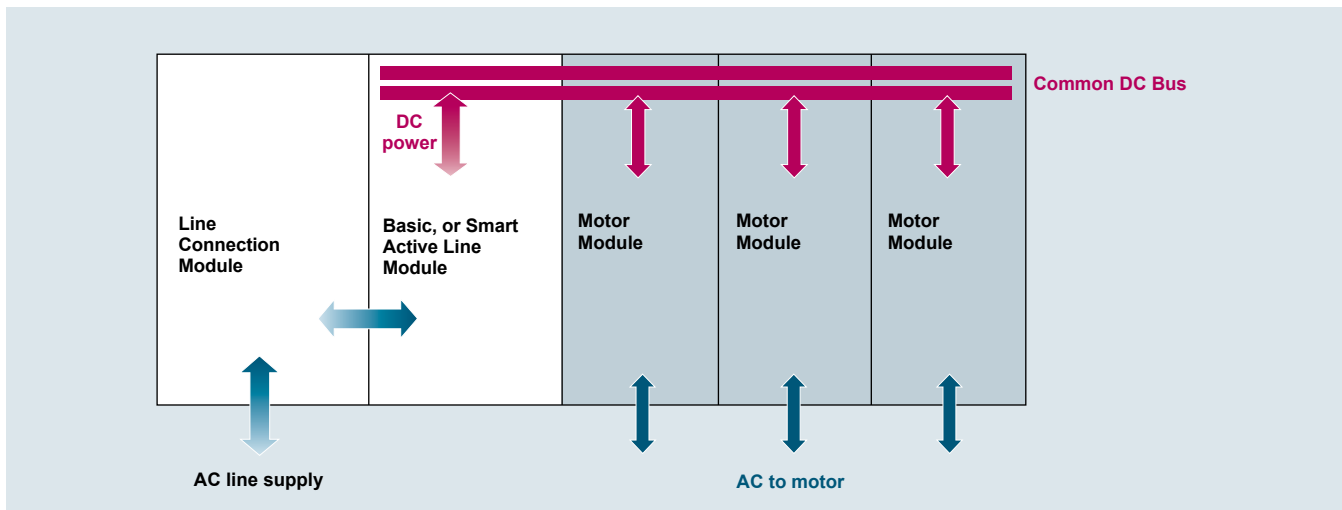

Basic power flow in a SINAMICS S120 Cabinet Module line-up

### Line Connection Modules – Overview



The Line Connection Module contains the disconnect device and short circuit protection (a circuit breaker plus fuses as required for SCCR), and when required additional components such as, for example, a contactor, line reactor and optionally AC and DC control power supplies. The Line Connection Module feeds 3-phase power to the line side converter – the Basic, Smart or Active Line Module.

Line Connection Modules are available for the following voltages and currents:

Line voltage	Rated input current
380 ... 480 V 3 ph.	AC 250 ... 3,000 A
500 ... 600 (690) V 3 ph.	AC 280 ... 3,000 A

### Design

Different versions exist depending on the rated input current:

- Units  $\leq 800$  A include a molded case circuit breaker (MCCB)
- Units  $> 800$  A include a fixed mounted insulated case circuit breaker (motorized power circuit breaker). Optionally, a draw-out circuit breaker can be supplied.

All Line Connection Modules additionally include semiconductor fuses as required for the high SCCR rating of power modules.

When Line Connection Modules are ordered, the type of Line Module used must be specified:

- for Basic Line Module: Option L43
- for Smart Line Module: Option L44
- for Active Line Module: Option L42

In some designs with motorized circuit breaker the DC bus must be precharged before the main circuit breaker can be closed. Interlocking circuitry for start-up sequencing is included. The circuit breaker should never be closed directly by bypassing the interlocks.

#### Line Connection Module with option L43 for Basic Line Module

For Basic Line Modules, the Line Connection Module includes a line reactor as standard. If there is sufficient impedance on the line side (for example, when using a dedicated drive isolation transformer) the line reactor can be excluded (option L22). This option is not available for parallel Basic Line Modules connected to a single Line Connection Module, as line reactors are required to ensure current sharing.

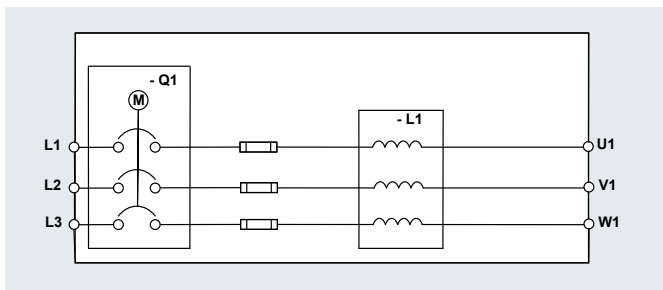

Example of a Line Connection Module for a Basic Line Module

For most Basic Line Module ratings, the precharge function is included within the Basic Line Module itself. For the largest (1880 A DC) Basic Line Module, the precharge circuitry is provided in the Line Connection Module.

An input isolation contactor is available for Line Connection Modules  $\leq 800$  A (with MCCB), by specifying option L13.

#### Line Connection Module with option L44 for Smart Line Module

For Smart Line Modules, the Line Connection Module always includes the power supply for the precharge circuit. For Line Connection Modules  $\leq 800$  A (with MCCB) an input contactor is standard, to bridge (bypass) the precharge circuit after the DC bus is charged. For Line Connector Modules  $>800$  A, the motorized circuit breaker is used for this function.

When provided, the line reactor is always included in the Smart Line Module cabinet.

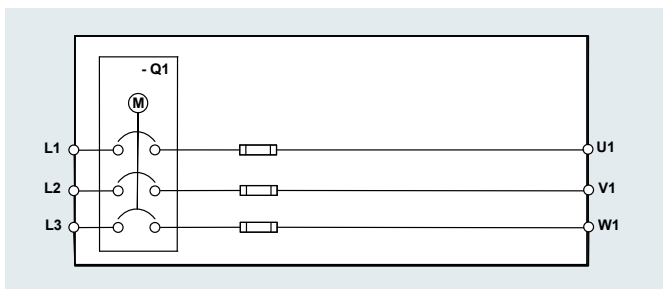

Example of a Line Connection Module for a Smart Line Module

## Line Connection Modules

### Design (continued)

#### Line Connection Module with option L42 for Active Line Module

For Active Line Modules, the Line Connection Module connects to the Active Interface Module. For the smaller Active Interface Module (frame sizes FI/FX and GI/GX), the Active Interface Module includes the precharge circuitry and the associated precharge and bridging contactors. For larger sizes the Line Connection Module includes the power supply for the precharge circuit. For Line Connection Modules  $\leq 800$  A (with MCCB), an input contactor is standard, to bridge the precharge circuit. For Line Connection Modules  $>800$  A, the motorized circuit breaker is used for this function.

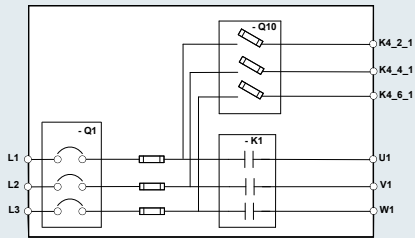

Example of a Line Connection Module for Active Line Modules  $<800$ A

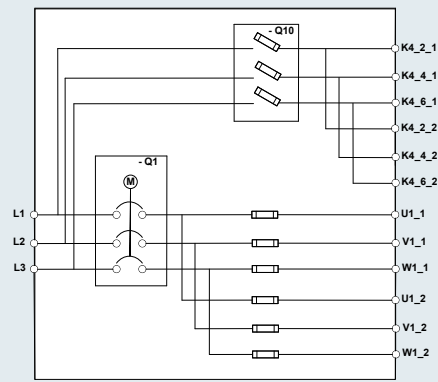

Example of a Line Connection Module for Active Line Modules in parallel connection

### Order numbers and option codes

When ordering a drive with options, add -Z to the order number followed by option codes separated by a "+" sign.

Example: **6SL3700-0LE32-5AU3-Z L43+M90+...**

- SINAMICS S120 CM is a standard product, defined by its order no. and option codes.
- "Y" options (+Y..) require additional text to describe the option. For example:  
**Y09 Special enclosure color RAL 1018 (traffic yellow)**

### Selection and ordering data

Line Connection Module			
Rated input current A		SCCR standard*	SCCR high* (option L70)
		kA	kA
Line voltage 380 ... 480 V 3ph. AC			
250	6SL3700-0LE32-5AU3	65	—
380	6SL3700-0LE34-0AU3	65	—
600	6SL3700-0LE36-3AU3	65	—
770	6SL3700-0LE38-0AU3	65	—
1000	6SL3700-0LE41-0AU3	65	84
1250	6SL3700-0LE41-3AU3	65	84
1600	6SL3700-0LE41-6AU3	65	100
2000	6SL3700-0LE42-0AU3	65	100
2000	6SL3700-0LE42-0BU3	65	84
2500	6SL3700-0LE42-5BU3	100	—
3000	6SL3700-0LE43-2BU3	100	—
Line voltage 500 ... 600 (690) V 3ph. AC			
280	6SL3700-0LG32-8AU3	25	—
380	6SL3700-0LG34-0AU3	25	—
600	6SL3700-0LG36-3AU3	25	—
770	6SL3700-0LG38-0AU3	35	—
1000	6SL3700-0LG41-0AU3	85	100
1250	6SL3700-0LG41-3AU3	85	100
1600	6SL3700-0LG41-6AU3	85	100
2000	6SL3700-0LG42-0BU3	85	100
2500	6SL3700-0LG42-5BU3	85	100
3000	6SL3700-0LG43-2BU3	85	100

Short circuit current ratings (SCCR) provided above are per UL508A supplement SB for Line Connection Modules in combination with Line Modules as listed in the table on the following page. The standard SCCR applies to the base part number. For Line Connection Modules rated 1,000 A and up, a high SCCR is optionally available by specifying option code L70.

\* Note: The SCCR of the line-up is additionally dependent on the SCCR of the smallest Motor Module it contains. The maximum value of the SCCR is determined by the power rating of any Motor Modules as follows.

Motor Module(s) $<600$ HP:	Maximum SCCR 65 kA
Motor Module(s) $<900$ HP:	Maximum SCCR 84 kA

When ordering a Line Connection Module it is essential to specify the option code for the type of Line Module that it is connected to, to ensure that it is correctly configured for its intended use. This applies particularly to interconnecting busbars, and power supplies for precharge circuits.

- Option L43 for a Basic Line Module
- Option L44 for a Smart Line Module
- Option L42 for an Active Line Module

### Assignment of Line Modules to Line Connection Modules

The table below shows the assignment of Basic, Smart or Active Line Modules to Line Connection Modules. These are the only available combinations. These combinations were evaluated by UL, and components are selected in compliance with the requirements of the National Electrical Code NFPA70.

Line Connection Module		Basic Line Module		Smart Line Module		Active Line Module	
Rated input current A		Rated input Current A		Rated input current A		Rated input current A	
<b>Line voltage 380 ... 480 V 3ph. AC</b>							
<b>250</b>	<b>6SL3700-0LE32-5AU3</b>	–	–	–	–	210	6SL3730-7TE32-1AU3
<b>380</b>	<b>6SL3700-0LE34-0AU3</b>	–	–	–	–	260	6SL3730-7TE32-6AU3
<b>600</b>	<b>6SL3700-0LE36-3AU3</b>	365	6SL3730-1TE34-2AU3	463	6SL3730-6TE35-5AU3	380	6SL3730-7TE33-8AU3
		460	6SL3730-1TE35-3AU3	–	–	490	6SL3730-7TE35-0AU3
<b>770</b>	<b>6SL3700-0LE38-0AU3</b>	710	6SL3730-1TE38-2AU3	614	6SL3730-6TE37-3AU3	605	6SL3730-7TE36-1AU3
<b>1000</b>	<b>6SL3700-0LE41-0AU3</b>	–	–	883	6SL3730-6TE41-1AU3	840	6SL3730-7TE38-4AU3
<b>1250</b>	<b>6SL3700-0LE41-3AU3</b>	1010	6SL3730-1TE41-2AU3	1093	6SL3730-6TE41-3AU3	985	6SL3730-7TE41-0AU3
<b>1600</b>	<b>6SL3700-0LE41-6AU3</b>	1265	6SL3730-1TE41-5AU3	1430	6SL3730-6TE41-7AU3	1405	6SL3730-7TE41-4AU3
<b>2000</b>	<b>6SL3700-0LE42-0AU3</b>	1630	6SL3730-1TE41-8AU3	–	–	–	–
<b>2000</b>	<b>6SL3700-0LE42-0BU3</b>	2 × 935	6SL3730-1TE41-2AU3	2 × 817	6SL3730-6TE41-1BU3	2 × 936	6SL3730-7TE41-0AU3
			6SL3730-1TE41-2CU3		6SL3730-6TE41-1CU3		6SL3730-7TE41-0CU3
<b>2500</b>	<b>6SL3700-0LE42-5BU3</b>	2 × 1170	6SL3730-1TE41-5AU3	2 × 1011	6SL3730-6TE41-3BU3	–	–
			6SL3730-1TE41-5CU3		6SL3730-6TE41-3CU3		
<b>3000</b>	<b>6SL3700-0LE43-2BU3</b>	2 × 1500	6SL3730-1TE41-8AU3	2 × 1323	6SL3730-6TE41-7BU3	2 × 1335	6SL3730-7TE41-4AU3
			6SL3730-1TE41-8CU3		6SL3730-6TE41-7CU3		6SL3730-7TE41-4CU3
<b>Line voltage 500 ... 600 (690) V 3ph. AC</b>							
<b>280</b>	<b>6SL3700-0LG32-8AU3</b>	260	6SL3730-1TG33-0AU3	–	–	–	–
<b>380</b>	<b>6SL3700-0LG34-0AU3</b>	375	6SL3730-1TG34-3AU3	–	–	–	–
<b>600</b>	<b>6SL3700-0LG36-3AU3</b>	575	6SL3730-1TG36-8AU3	463	6SL3730-6TG35-5AU3	575	6SL3730-7TG35-8AU3
<b>770</b>	<b>6SL3700-0LG38-0AU3</b>	–	–	757	6SL3730-6TG38-8AU3	735	6SL3730-7TG37-4AU3
<b>1000</b>	<b>6SL3700-0LG41-0AU3</b>	925	6SL3730-1TG41-1AU3	–	–	–	–
<b>1250</b>	<b>6SL3700-0LG41-3AU3</b>	1180	6SL3730-1TG41-4AU3	1009	6SL3730-6TG41-2AU3	1025	6SL3730-7TG41-0AU3
<b>1600</b>	<b>6SL3700-0LG41-6AU3</b>	1580	6SL3730-1TG41-8AU3	1430	6SL3730-6TG41-7AU3	1270	6SL3730-7TG41-3AU3
<b>2000</b>	<b>6SL3700-0LG42-0BU3</b>	2 × 855	6SL3730-1TG41-1AU3	2 × 700	6SL3730-6TG38-8BU3	2 × 698	6SL3730-7TG37-4AU3
			6SL3730-1TG41-1CU3		6SL3730-6TG38-8CU3		6SL3730-7TG37-4CU3
		–	–	2 × 934	6SL3730-6TG41-2BU3	2 × 974	6SL3730-7TG41-0AU3
					6SL3730-6TG41-2CU3		6SL3730-7TG41-0CU3
<b>2500</b>	<b>6SL3700-0LG42-5BU3</b>	2 × 1092	6SL3730-1TG41-4AU3	–	–	2 × 1206	6SL3730-7TG41-3AU3
			6SL3730-1TG41-4CU3				6SL3730-7TG41-3CU3
<b>3000</b>	<b>6SL3700-0LG43-2BU3</b>	2 × 1462	6SL3730-1TG41-8AU3	2 × 1323	6SL3730-6TG41-7BU3	–	–
			6SL3730-1TG41-8CU3		6SL3730-6TG41-7CU3		
<i>Entries in italics:</i>	Parallel connection of two Line Modules with a single Line Connection Module: The current derating factors as listed below are already included in the current values listed above: <ul style="list-style-type: none"> <li>• 7.5% for Basic Line Modules</li> <li>• 7.5% for Smart Line Modules</li> <li>• 5% for Active Line Modules</li> </ul>						

# SINAMICS S120 Cabinet Modules

## Line Connection Modules

### Technical data

Line voltage 380 ... 480 V 3 ph. AC		Line Connection Module					
		6SL3700-OLE32-5AU3	6SL3700-OLE34-0AU3	6SL3700-OLE36-3AU3	6SL3700-OLE38-0AU3	6SL3700-OLE41-0AU3	6SL3700-OLE41-3AU3
<b>Line Current</b> • Rated current $I_{NE}$	A	<b>250</b>	<b>380</b>	<b>600</b>	<b>770</b>	<b>1,000</b>	<b>1,250</b>
<b>Current Demand</b> • 24V DC auxiliary power supply	A	–	–	–	–	–	–
• 230 V 2 ph. AC	A	–	–	–	–	1.07	1.07
• 230 V 2 ph. AC (Opt. L43 BLM) <sup>1) 2)</sup>							
- Making current	A	3.6	3.6	3.6	10.8	0.5	0.5
- Holding current	A	0.04	0.04	0.04	0.12	0.06	0.06
<b>Power loss, max.<sup>3)</sup></b> at 60 Hz 460V [50 Hz 400V]							
- Option L42 ALM / L44 SLM	kW	0.115 [0.115]	0.19 [0.19]	0.31 [0.31]	0.39 [0.39]	0.18 [0.18]	0.29 [0.29]
- Option L43 BLM	kW	–	–	0.675 [0.675]	0.74 [0.74]	–	0.787 [0.787]
<b>Cooling air requirement (L43 BLM)<sup>1)</sup></b>	cfm [m <sup>3</sup> /s]	–	–	–	–	763 [0.36]	763 [0.36]
<b>Sound pressure level <math>L_{pA}</math> (1m)</b> at 60 [50] Hz (Option L43 BLM) <sup>1)</sup>	dB(A)	–	–	–	–	70 [68]	70 [68]
<b>Line supply connection L1, L2, L3</b> • Conductor size, max.		2x250 MCM	2x250 MCM	2x600 MCM	3x500 MCM	8x 500 MCM	8x 500 MCM
<b>Ground (PE) connection</b> • Conductor size, max.		500 MCM	500 MCM	500 MCM	500 MCM	500 MCM	500 MCM
<b>Short Circuit Current Rating (SCCR)</b> In combination with Line module							
• Standard	kA	65	65	65	65	65	65
• High (option L70)	kA	–	–	–	–	84	84
<b>Enclosure (base design)</b>		IP20	IP20	IP20	IP20	IP20	IP20
<b>Enclosure dimensions, nominal</b>							
• Width	inch [mm]	24 [600]	24 [600]	24 [600]	24 [600]	24 [600]	24 [600]
• Height <sup>4)</sup>	inch [mm]	87 [2,200]	87 [2,200]	87 [2,200]	87 [2,200]	87 [2,200]	87 [2,200]
• Depth	inch [mm]	24 [600]	24 [600]	24 [600]	24 [600]	24 [600]	24 [600]
<b>Weight, approx.</b>							
- Option L42 ALM / L44 SLM	lb [kg]	460 [210]	510 [230]	680 [310]	750 [340]	990 [450]	1,040 [470]
- Option L43 BLM lb [kg]	lb [kg]	–	–	790 [360]	930 [420]	–	1,260 [570]
<b>Frame size</b>		FL	FL	GL	HL	JL	JL

1) With option L43 (for Basic Line Module) only.

2) Current demand of contactors/circuit breakers and fans with NEMA 1 filtered (IP23), IP43, or NEMA 12 ventilated (IP54) enclosure.

3) The specified power loss represents the maximum value at 100 % utilization. The value is lower under normal operating conditions.

4) The enclosure height increases by 10" (250 mm) for NEMA 1 (IP21) and by 16" (400 mm) for NEMA 1 filtered (IP23), IP43 and NEMA 12 ventilated (IP54) enclosure.



### Technical data

Line voltage 380 ... 480 V 3 ph. AC		Line Connection Module				
		6SL3700-OLE41-6AU3	6SL3700-OLE42-0AU3	6SL3700-OLE42-0BU3	6SL3700-OLE42-5BU3	6SL3700-OLE43-2BU3
		<i>For parallel connected line modules</i>				
<b>Line Current</b> • Rated current $I_{NE}$	A	1,600	2,000	2,000	2,500	3,000
<b>Current Demand</b> • 24V DC auxiliary power supply	A	–	–	–	–	–
• 230 V 2 ph. AC	A	1.07	2.14	2.14	2.14	2.14
• 230 V 2 ph. AC (Opt. L43 BLM) <sup>1) 2)</sup> - Making current	A	0.5	0.5	0.5	0.5	0.5
- Holding current	A	0.06	0.06	0.06	0.06	0.06
<b>Power loss, max.<sup>3)</sup></b> at 60 Hz 460V [50 Hz 400V]						
- Option L42 ALM / L44 SLM	kW	0.41 [0.41]	0.60 [0.60]	0.60 [0.60]	0.95 [0.95]	0.95 [0.95]
- Option L43 BLM	kW	1.186 [1.186]	1.366 [1.366]	1.594 [1.594]	2.502 [2,502]	2.482 [2,482]
<b>Cooling air requirement (L43 BLM)<sup>1)</sup></b>	cfm [m <sup>3</sup> /s]	763 [0.36]	1,526 [0.72]	1,526 [0.72]	1,526 [0.72]	1,526 [0.72]
<b>Sound pressure level <math>L_{pA}</math> (1m)</b> at 60 [50] Hz (Option L43 BLM) <sup>1)</sup>	dB(A)	70 [68]	72 [70]	72 [70]	72 [70]	72 [70]
<b>Line supply connection L1, L2, L3</b> • Conductor size, max.		10x 500 MCM	10x 500 MCM	10x 500 MCM	10x 500 MCM	10x 600 MCM
<b>Ground (PE) connection</b> • Conductor size, max.		500 MCM	500 MCM	500 MCM	500 MCM	500 MCM
<b>Short Circuit Current Rating (SCCR)</b> In combination with Line module						
• Standard	kA	65	65	65	100	100
• High (option L70)	kA	100	100	84	–	–
<b>Enclosure (base design)</b>		IP20	IP20	IP20	IP20	IP20
<b>Enclosure dimensions, nominal</b>						
• Width	inch [mm]	24 [600]	24 [600]	39.4 [1,000]	39.4 [1,000]	39.4 [1,000]
• Height <sup>4)</sup>	inch [mm]	87 [2,200]	87 [2,200]	87 [2,200]	87 [2,200]	87 [2,200]
• Depth	inch [mm]	24 [600]	24 [600]	24 [600]	24 [600]	24 [600]
<b>Weight, approx.</b>						
- Option L42 ALM / L44 SLM	lb [kg]	1,040 [470]	1,080 [490]	1,360 [600]	1,370 [620]	1,590 [720]
- Option L43 BLM lb [kg]	lb [kg]	1,480 [670]	1,500 [680]	2,160 [980]	2,200 [1,000]	2,380 [1,080]
<b>Frame size</b>		JL	JL	KL	KL	LL

<sup>1)</sup> With option L43 (for Basic Line Module) only.

<sup>2)</sup> Current demand of contactors/circuit breakers and fans with NEMA 1 filtered (IP23), IP43, or NEMA 12 ventilated (IP54) enclosure.

<sup>3)</sup> The specified power loss represents the maximum value at 100% utilization. The value is lower under normal operating conditions.

<sup>4)</sup> The enclosure height increases by 10" (250 mm) for NEMA 1 (IP21) and by 16" (400 mm) for NEMA 1 filtered (IP23), IP43 and NEMA 12 ventilated (IP54) enclosure.

# SINAMICS S120 Cabinet Modules

## Line Connection Modules

### Technical data

Line voltage 500 ... 600 (690) V 3 ph. AC Note: UL Listing is valid only for ≤ 600 V		Line Connection Module				
		6SL3700- OLG32-8AU3	6SL3700- OLG34-0AU3	6SL3700- OLG36-3AU3	6SL3700- OLG38-0AU3	6SL3700- OLG41-0AU3
<b>Line Current</b> • Rated current $I_{NE}$	A	<b>280</b>	<b>380</b>	<b>600</b>	<b>770</b>	<b>1,000</b>
<b>Current Demand</b> • 24V DC auxiliary power supply	A	–	–	–	–	–
• 230 V 2 ph. AC	A	–	–	–	–	1.07
• 230 V 2 ph. AC (Opt. L43 BLM) <sup>1) 2)</sup>						
- Making current	A	3.6	3.6	3.6	10.8	0.5
- Holding current	A	0.04	0.04	0.04	0.20	0.06
<b>Power loss, max.</b> <sup>3)</sup> at 60 Hz 460V [50 Hz 400V]						
- Option L42 ALM / L44 SLM	kW	0.125 [0.125]	0.19 [0.19]	0.31 [0.31]	0.39 [0.39]	0.18 [0.18]
- Option L43 BLM	kW	0.402 [0.402]	0.668 [0.668]	0.794 [0.794]	–	0.963 [0.963]
<b>Cooling air requirement</b> (L43 BLM) <sup>1)</sup>	cfm [m <sup>3</sup> /s]	–	–	–	–	763 [0.36]
<b>Sound pressure level <math>L_{pA}</math></b> (1m) at 60 [50] Hz (Option L43 BLM) <sup>1)</sup>	dB(A)	–	–	–	–	70 [68]
<b>Line supply connection L1, L2, L3</b> • Conductor size, max.		2X 250 MCM	2X 250 MCM	2x 600 MCM	3x 500 MCM	8x 500 MCM
<b>Ground (PE) connection</b> • Conductor size, max.		500 MCM	500 MCM	500 MCM	500 MCM	500 MCM
<b>Short Circuit Current Rating (SCCR)</b> In combination with Line module						
• Standard	kA	25	25	25	35	85
• High (option L70)	kA	–	–	–	–	100
<b>Enclosure (base design)</b>		IP20	IP20	IP20	IP20	IP20
<b>Enclosure dimensions, nominal</b>						
• Width	inch [mm]	24 [600]	24 [600]	24 [600]	24 [600]	24 [600]
• Height <sup>4)</sup>	inch [mm]	87 [2,200]	87 [2,200]	87 [2,200]	87 [2,200]	87 [2,200]
• Depth	inch [mm]	24 [600]	24 [600]	24 [600]	24 [600]	24 [600]
<b>Weight, approx.</b>						
- Option L42 ALM / L44 SLM	lb [kg]	490 [220]	510 [230]	680 [310]	750 [340]	990 [450]
- Option L43 BLM	lb [kg]	570 [260]	680 [310]	880 [400]	–	1,430 [650]
<b>Frame size</b>		FL	FL	GL	HL	JL

1) With option L43 (for Basic Line Module) only.

2) Current demand of contactors/circuit breakers and fans with NEMA 1 filtered (IP23), IP43, or NEMA 12 ventilated (IP54) enclosure.

3) The specified power loss represents the maximum value at 100 % utilization. The value is lower under normal operating conditions.

4) The enclosure height increases by 10" (250 mm) for NEMA 1 (IP21) and by 16" (400 mm) for NEMA 1 filtered (IP23), IP43 and NEMA 12 ventilated (IP54) enclosure.

### Technical data

Line voltage 500 ... 600 (690) V 3 ph. AC Note: UL Listing is valid only for ≤ 600 V		Line Connection Module				
		6SL3700- OLG41-3AU3	6SL3700- OLG41-6AU3	6SL3700- OLG42-0BU3	6SL3700- OLG42-5BU3	6SL3700- OLG43-2BU3
		For parallel connected line modules				
<b>Line Current</b> • Rated current $I_{NE}$	A	1,250	1,600	2,000	2,500	3,000
<b>Current Demand</b>						
• 24V DC auxiliary power supply	A	–	–	–	–	–
• 230 V 2 ph. AC	A	1.07	1.07	2.14	2.14	2.14
• 230 V 2 ph. AC (Opt. L43 BLM) <sup>1) 2)</sup>						
- Making current	A	0.5	0.5	0.5	0.5	0.5
- Holding current	A	0.06	0.06	0.06	0.06	0.06
<b>Power loss, max.</b> <sup>3)</sup> at 60 Hz 460V [50 Hz 400V]						
- Option L42 ALM / L44 SLM	kW	0.29 [0.29]	0.41 [0.41]	0.60 [0.60]	0.95 [0.95]	0.95 [0.95]
- Option L43 BLM	kW	1.073 [1.073]	1.387 [1.387]	2.166 [2.166]	2.166 [2.166]	2.894 [2.894]
<b>Cooling air requirement</b> (L43 BLM) <sup>1)</sup>	cfm [m <sup>3</sup> /s]	763 [0.36]	763 [0.36]	1,526 [0.72]	1,526 [0.72]	1,526 [0.72]
<b>Sound pressure level <math>L_{pA}</math></b> (1 m) at 60 [50] Hz (Option L43 BLM) <sup>1)</sup>	dB(A)	70 [68]	70 [68]	72 [70]	72 [70]	72 [70]
<b>Line supply connection L1, L2, L3</b> • Conductor size, max.		8x 500 MCM	8x 500 MCM	10x 500 MCM	10x 500 MCM	10x 600 MCM
<b>Ground (PE) connection</b> • Conductor size, max.		500 MCM	500 MCM	500 MCM	500 MCM	500 MCM
<b>Short Circuit Current Rating (SCCR)</b> In combination with Line module						
• Standard	kA	85	85	85	85	85
• High (option L70)	kA	100	100	100	100	100
<b>Enclosure (base design)</b>		IP20	IP20	IP20	IP20	IP20
<b>Enclosure dimensions, nominal</b>						
• Width	inch [mm]	24 [600]	24 [600]	39.4 [1,000]	39.4 [1,000]	39.4 [1,000]
• Height <sup>4)</sup>	inch [mm]	87 [2,200]	87 [2,200]	87 [2,200]	87 [2,200]	87 [2,200]
• Depth	inch [mm]	24 [600]	24 [600]	24 [600]	24 [600]	24 [600]
<b>Weight, approx.</b>						
- Option L42 ALM / L44 SLM	lb [kg]	1,040 [470]	1,080 [490]	1,320 [600]	1,370 [620]	1,590 [720]
- Option L43 BLM lb [kg]		1,480 [670]	1,500 [680]	2,160 [980]	2,200 [1,000]	2,380 [1,080]
Frame size		JL	JL	KL	KL	LL

1) With option L43 (for Basic Line Module) only.

2) Current demand of contactors/circuit breakers and fans with NEMA 1 filtered (IP23), IP43, or NEMA 12 ventilated (IP54) enclosure.

3) The specified power loss represents the maximum value at 100 % utilization. The value is lower under normal operating conditions.

4) The enclosure height increases by 10" (250 mm) for NEMA 1 (IP21) and by 16" (400 mm) for NEMA 1 filtered (IP23), IP43 and NEMA 12 ventilated (IP54) enclosure.

# SINAMICS S120 Cabinet Modules

## Line Connection Modules

### Options

The table below lists the available options for Line Connection Modules (refer to **Description of the Options** for details).

Available Options	Option code	Rated current		
		≤ 800A	800...2,000A	≥ 2,000 A
TM150 Terminal Module for temperature monitoring (qty. 1)	G51	✓	✓	✓
TM150 Terminal Modules for temperature monitoring (qty. 2)	G52	✓	✓	✓
TM150 Terminal Modules for temperature monitoring (qty. 3)	G53	✓	✓	✓
TM150 Terminal Modules for temperature monitoring (qty. 4)	G54	✓	✓	✓
Power supply for blowers, mounted in Line Connection Module	K70	✓	✓	✓
Auxiliary power supplies, mounted in Line Connection Module	K76	✓	✓	✓
Input contactor (only for ≤ 800A)	L13	✓	–	–
Without input line reactor (only for L43 Basic Line Module)	L22	✓	✓	–
Surge Protection for ungrounded (IT) power supply	L21	✓	✓	✓
Draw-out circuit breaker	L25	–	✓	✓
Current transformer upstream of circuit breaker	L41	✓	✓	✓
Line Connection Module for Active Line Modules	L42	✓	✓	✓
Line Connection Module for Basic Line Modules	L43	✓	✓	✓
Line Connection Module for Smart Line Modules	L44	✓	✓	✓
EMERGENCY OFF pushbutton installed in the cabinet door	L45	✓	✓	✓
Enclosure space heater	L55	✓	✓	✓
High SCCR (short circuit current rating) 84 or 100 kA	L70	–	✓	✓
Insulation Monitor for ungrounded supplies	L87	✓	✓	✓
Base (plinth) 100mm	M06	✓	✓	✓
Base (plinth) 200mm (cable marshalling space)	M07	✓	✓	✓
Enclosure NEMA 1 (IP21)	M21	✓	✓	✓
Enclosure NEMA 1 filtered (IP23) [includes M60]	M23	✓	✓	✓
Side panel (left)	M27	✓	✓	✓
Enclosure IP43 [includes M60]	M43	✓	✓	✓
Enclosure NEMA 12 (ventilated) (IP54) [includes M60]	M54	✓	✓	✓
Solid cabinet door (no ventilation openings, air inlet through floor)	M59	✓	✓	✓
Additional touch protection [included in M23, M43 and M54]	M60	✓	✓	✓
EMC shield busbar	M70	✓	✓	✓
DC busbar system ( $I_d = 1,170$ A, 1x 60 x 10 mm)	M80	✓	✓	✓
DC busbar system ( $I_d = 1,500$ A, 1x 80 x 10 mm)	M81	✓	✓	✓
DC busbar system ( $I_d = 1,840$ A, 1x 100 x 10 mm)	M82	✓	✓	✓
DC busbar system ( $I_d = 2,150$ A, 2x 60 x 10 mm)	M83	✓	✓	✓
DC busbar system ( $I_d = 2,730$ A, 2x 80 x 10 mm)	M84	✓	✓	✓
DC busbar system ( $I_d = 3,320$ A, 2x 100 x 10 mm)	M85	✓	✓	✓
DC busbar system ( $I_d = 3,720$ A, 3x 80 x 10 mm)	M86	✓	✓	✓
DC busbar system ( $I_d = 4,480$ A, 3x 100 x 10 mm)	M87	✓	✓	✓
Lifting beam/eye bolts	M90	✓	✓	✓
Input power meter [includes L41]	P10	✓	✓	✓
Input power meter with PROFIBUS [includes L41]	P11	✓	✓	✓
UL listing per UL508A [requires M23, M43 or M54]	U90	✓	✓	✓
cUL listing per UL508A for Canada [requires M23, M43 or M54 plus T58]	U91	✓	✓	✓
Special enclosure paint color [specify color]	Y09	✓	✓	✓
Assembly into transport sections [specify sections]	Y11	✓	✓	✓
1-line label for customer text, 40 x 80 mm [specify text]	Y31	✓	✓	✓
2-line label for customer text, 40 x 180 mm [specify text]	Y32	✓	✓	✓
4-line label for customer text, 40 x 180 mm [specify text]	Y33	✓	✓	✓

### Options

Available Options (continued)	Option code	≤ 800A	Rated current 800...2,000A	≥ 2,000 A
Customer drawings in DXF format	D02	✓	✓	✓
Advance copy of customer documentation in PDF format	D14	✓	✓	✓
Documentation English/French	D58	✓	✓	✓
Nameplate English/French	T58	✓	✓	✓
Visual Inspection by customer	F03	✓	✓	✓
Witnessed or observed function test without motor	F71	✓	✓	✓
Witnessed or observed test incl. high-voltage and insulation test	F77	✓	✓	✓
Customer specific test (on request)	F97	✓	✓	✓

### Option combination matrix for Line Connection Modules

The following tables provide an overview of possible and impermissible combinations of standard options. Please refer to the descriptions of options for more information. Custom configurations may be possible to provide combinations not available as standard – please contact the factory.

✓	Combination is possible
–	Combination is not possible

### Electrical Options

	K70	K76	L13	L22	L25	L41	L42	L43	L44	P10	P11
K70		–	✓	✓	✓	✓	✓	✓	✓	✓	✓
K76	–		✓	✓	✓	✓	✓	✓	✓	✓	✓
L13	✓	✓		✓	–	✓	✓	✓	✓	✓	✓
L22	✓	✓	✓		✓	✓	–	✓	–	✓	✓
L25	✓	✓	–	✓		✓	✓	✓	✓	✓	✓
L41	✓	✓	✓	✓	✓		✓	✓	✓	–	–
L42	✓	✓	✓	–	✓	✓		–	–	✓	✓
L43	✓	✓	✓	✓	✓	✓	–		–	✓	✓
L44	✓	✓	✓	–	✓	✓	–	–		✓	✓
P10	✓	✓	✓	✓	✓	–	✓	✓	✓		✓
P11	✓	✓	✓	✓	✓	–	✓	✓	✓	✓	

### Mechanical Options

	M06	M07	M21	M23	M43	M54	M59	M60	M90	Y11	U90	U91
M06		–	✓	✓	✓	✓	✓	✓	✓	✓	✓	✓
M07	–		✓	✓	✓	✓	✓	✓	✓	✓	✓	✓
M21	✓	✓		–	–	–	✓	✓	✓	✓	–	–
M23	✓	✓	–		–	–	✓	–	✓	✓	✓	✓
M43	✓	✓	–	–		–	✓	–	✓	✓	✓	✓
M54	✓	✓	–	–	–		✓	–	✓	✓	✓	✓
M59	✓	✓	✓	✓	✓	✓		✓	✓	✓	✓	✓
M60	✓	✓	✓	–	–	–	✓		✓	✓	–	–
M90	✓	✓	✓	✓	✓	✓	✓	✓		–	✓	✓
Y11	✓	✓	✓	✓	✓	✓	✓	✓	–		✓	✓
U90	✓	✓	–	✓	✓	✓	✓	–	✓	✓		–
U91	✓	✓	–	✓	✓	✓	✓	–	✓	✓	–	

# SINAMICS S120 Cabinet Modules

## Line Connection Modules

### Options

#### DC busbar system Options

Within a line-up, all DC bus needs to be of the same width (60, 80 or 100 mm). DC bus current ratings may vary within a line-up by using either a single busbar, or two or three busbars in parallel per pole.

The following table indicates which busbar options for the various cabinet modules may be combined within a line-up.



Combination is possible



Combination is not possible

	M80	M81	M82	M83	M84	M85	M86	M87
M80		-	-	✓	-	-	-	-
M81	-		-	-	✓	-	✓	-
M82	-	-		-	-	✓	-	✓
M83	✓	-	-		-	-	-	-
M84	-	✓	-	-		-	✓	-
M85	-	-	✓	-	-		-	✓
M86	-	✓	-	-	✓	-		-
M87	-	-	✓	-	-	✓	-	

#### Label Options

	Y31	Y32	Y33
Y31		-	-
Y32	-		-
Y33	-	-	

### Overview



Basic Line Modules are compact line feeds that supply power from the AC supply to the DC bus – power regeneration from the DC bus back to the line is not possible. They are used when energy does not need to be fed back into the supply network.

If any of the loads in the line-up regenerate more power than can be absorbed by other loads, braking modules with resistors are required to convert the excess energy into heat.

Basic Line Modules are available for the following voltages and currents. Power ratings can be increased by connecting up to four identical Basic Line Modules in parallel.

Line voltage	Rated power
380 ... 480 V 3 ph. AC	200 ... 1,000 kW
500 ... 600 (690) V 3 ph. AC	200 (250) ... 1,250 (1,500) kW

A Basic Line Module is a 6-pulse rectifier bridge. For low harmonic feedback it is possible to configure multiple Basic Line Modules in 12-, 18- or 24-pulse configurations in combination with phase shifting transformers. Alternatively, line harmonics filters are available to reduce harmonics.

For Basic Line Modules, the Line Connection Module includes a line reactor as standard. If there is sufficient impedance on the line side (for example, when using a dedicated drive isolation transformer) the line reactor can be excluded (option L22). This option is not available for parallel Basic Line Modules connected to a single Line Connection Module, as line reactors are required to ensure current sharing.

For additional information, please refer to the [SINAMICS Low Voltage Engineering Manual](#).

### Design

Basic Line Modules are available in different frame sizes. With frame sizes FB and GB, a fully controlled thyristor bridge is used to pre-charge the DC bus (Basic Line Modules and connected Motor Modules). During operation, the thyristors are fired with a trigger delay angle of 0°.

Basic Line Modules, frame size GD for 900 kW (480 V) or 1,300 kW (600 V) use a diode bridge, and the DC bus is precharged via a separate line side precharge circuit located in the Line Connection Module (option L43, Line Connection Module for Basic Line Module).

#### Parallel connection of Basic Line Modules to increase the power rating

There are two alternative arrangements for connecting Line Modules in parallel to obtain drive line-ups with a higher power rating.

#### Two Basic Line Modules supplied with power via two separate Line Connection Modules

With this arrangement, each Basic Line Module is supplied by a Line Connection Module, each of which includes a circuit breaker disconnect and fuses. Basic Line Modules with their associated Line Connection Modules may be located anywhere in the line-up.

Note that for a line-up with multiple disconnects special lock out/tag out procedures may be required on site.

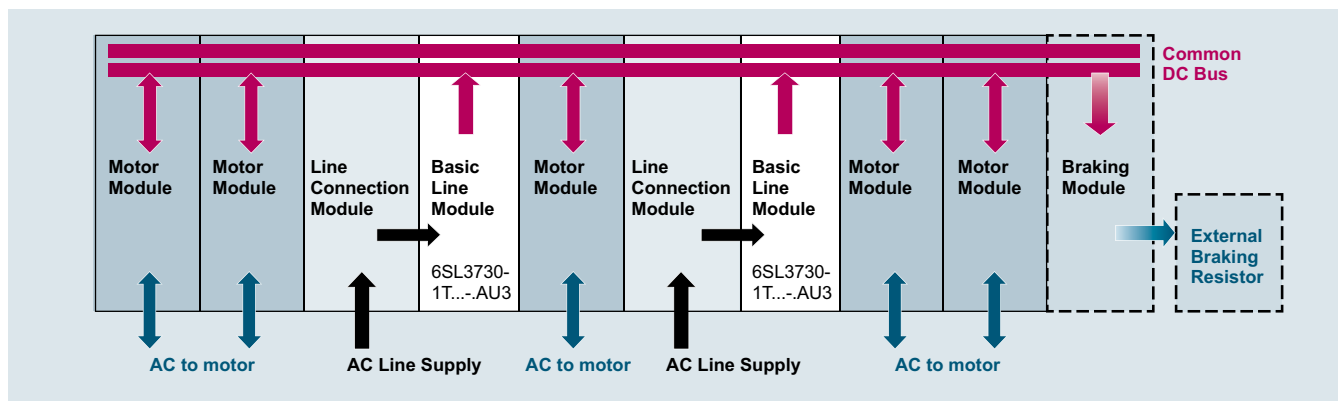

# SINAMICS S120 Cabinet Modules

## Basic Line Modules

### Design

Two **Basic Line Modules** supplied with power via a single **Line Connection Module**

In the alternative arrangement, two Basic Line Modules can be connected to the left and right of a single Line Connection Module, which results in a very compact design for the line infeed. The power connections on the Basic Line Module on the left of the Line Connection Module are a

mirror image of the standard unit mounted to its right. The Basic Line Module to the left has an order no. ending in CU3, example: 6SL3730-1T...-CU3.

The Line Connection Module for parallel connection includes a single circuit breaker with two sets of line fuses, for selective individual protection of each line module.

3

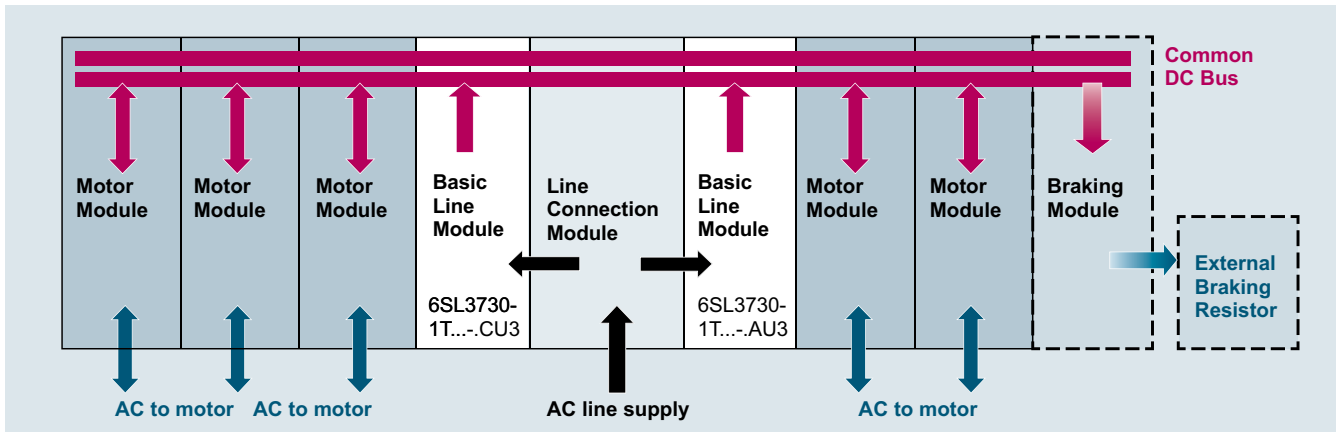

#### Note:

Please note that only Basic Line Modules with exactly the same output rating may be connected in parallel. Due to the possibility of unequal current sharing the rated current of the Basic Line Modules must be derated by 7.5%.

Basic Line Modules connected in parallel are operated on a common control unit, the required DRIVE-CLiQ cables need to be considered.

For additional information, please refer to the [SINAMICS Low Voltage Engineering Manual](#).

### Selection and ordering guide

Rated power at 460 (400) V kW	Note for parallel connection Mounting relative to Line Connection Module	Basic Line Module Order No.
Line voltage 380 ... 480 V 3ph. AC (DC bus voltage 510 ... 650 V DC)		
250 (200)	–	6SL3730-1TE34-2AU3
300 (250)	–	6SL3730-1TE35-3AU3
450 (400)	–	6SL3730-1TE38-2AU3
630 (560)	–	6SL3730-1TE41-2AU3
	Left	6SL3730-1TE41-2CU3
800 (710)	–	6SL3730-1TE41-5AU3
	Left	6SL3730-1TE41-5CU3
1,000 (900)	–	6SL3730-1TE41-8AU3
	Left	6SL3730-1TE41-8CU3

Rated power at 575 (690) V kW	Note for parallel connection Mounting relative to Line Connection Module	Basic Line Module Order No.
Line voltage 500 ... 600 (690) V 3ph. AC (DC bus voltage 675 ... 810 (930) V DC)		
200 (250)	–	6SL3730-1TG33-0AU3
300 (355)	–	6SL3730-1TG34-3AU3
450 (560)	–	6SL3730-1TG36-8AU3
750 (900)	–	6SL3730-1TG41-1AU3
	Left	6SL3730-1TG41-1CU3
900 (1,100)	–	6SL3730-1TG41-4AU3
	Left	6SL3730-1TG41-4CU3
1,200 (1,500)	–	6SL3730-1TG41-8AU3
	Left	6SL3730-1TG41-8CU3



### Block diagram

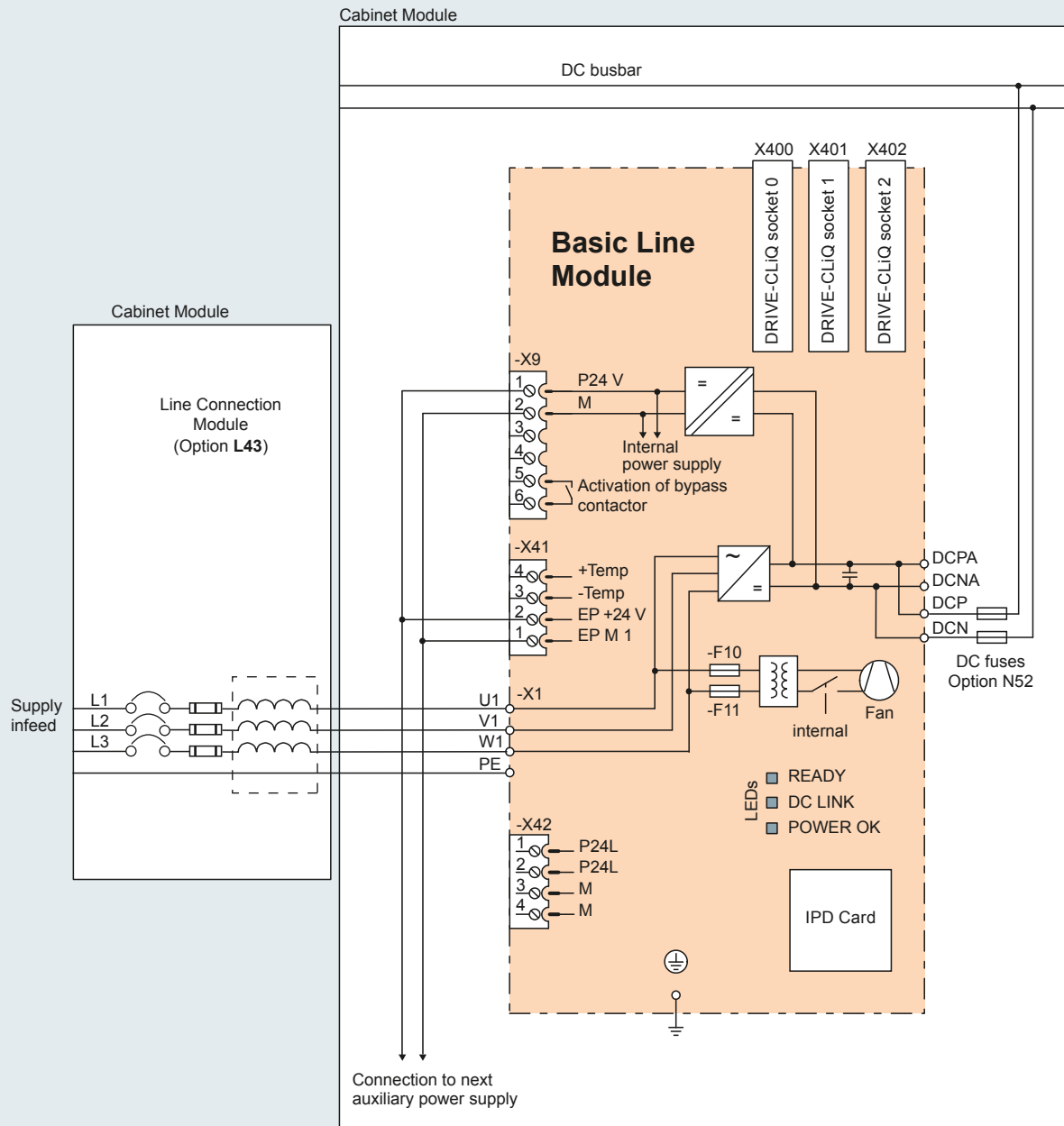

Connection example of a Basic Line Module

# SINAMICS S120 Cabinet Modules

## Basic Line Modules

### Technical data

Line Voltage 380 ... 480 V 3 ph. AC		Basic Line Module					
		6SL3730-1TE34-2AU3	6SL3730-1TE35-3AU3	6SL3730-1TE38-2AU3	6SL3730-1TE41-2AU3	6SL3730-1TE41-5AU3	6SL3730-1TE41-8AU3
<i>For parallel connection, mounted to the left of the Line Connection Module</i>					6SL3730-1TE41-2CU3	6SL3730-1TE41-5CU3	6SL3730-1TE41-8CU3
<b>Rated power</b>							
• For $I_{NDC}$ (60 Hz, 460 V)	kW	250	300	450	630	800	1,000
• For $I_{NDC}$ (50 Hz, 400 V)	kW	200	250	400	560	710	900
• For $I_{HDC}$ (60 Hz, 460 V)	kW	200	250	355	500	630	800
• For $I_{HDC}$ (50 Hz, 400 V)	kW	160	200	315	450	560	705
<b>DC bus current</b>							
• Rated current $I_{NDC}$	A	420	530	820	1,200	1,500	1,880
• Base load current $I_{HDC}^{1)}$	A	328	413	640	936	1,170	1,467
• Maximum current $I_{maxDC}$	A	630	795	1,230	1,800	2,250	2,820
<b>Input current</b>							
• Rated current $I_{NE}$	A	365	460	710	1,010	1,265	1,630
• Maximum current $I_{maxE}$	A	547	690	1,065	1,515	1,897	2,380
<b>Current demand</b>							
• 24V DC auxiliary power supply	A	1.1	1.1	1.1	1.1	1.1	1.1
• 460 (400) V AC <sup>2)</sup>	A	Internal	Internal	Internal	Internal	Internal	Internal
<b>DC bus capacitance</b>							
• Basic Line Module	μF	7,200	9,600	14,600	23,200	29,000	34,800
• Drive line-up, max.	μF	57,600	76,800	116,800	185,600	232,000	139,200
<b>Power loss, max. <sup>3)</sup></b>							
• At 60 Hz 460V [50 Hz 400V]	kW	1.9 [1.9]	2.1 [2.1]	3.2 [3.2]	4.6 [4.6]	5.5 [5.5]	6.9 [6.9]
<b>Cooling air requirement</b>		cfm [m <sup>3</sup> /s]	360 [0.17]	360 [0.17]	360 [0.17]	763 [0.36]	763 [0.36]
<b>Sound pressure level <math>L_{pA}</math> (1m) at 60 [50] Hz</b>		dB(A)	68 [66]	68 [66]	68 [66]	73 [71]	73 [71]
<b>Output cable length, max. <sup>4)</sup></b>							
• Shielded	ft [m]	8,500 [2,600]	8,500 [2,600]	8,500 [2,600]	13,100 [4,000]	13,100 [4,000]	15,750 [4,800]
• Unshielded	ft [m]	12,800 [3,900]	2,800 [3,900]	12,800 [3,900]	19,700 [6,000]	19,700 [6,000]	23,600 [7,200]
<b>Enclosure (base design)</b>			IP20	IP20	IP20	IP20	IP20
<b>Enclosure dimensions, nominal</b>							
• Width	inch [mm]	16 [400]	16 [400]	16 [400]	16 [400]	16 [400]	16 [400]
• Height <sup>5)</sup>	inch [mm]	87 [2,200]	87 [2,200]	87 [2,200]	87 [2,200]	87 [2,200]	87 [2,200]
• Depth	inch [mm]	24 [600]	24 [600]	24 [600]	24 [600]	24 [600]	24 [600]
<b>Weight, approx.</b>		lb [kg]	366 [166]	366 [166]	366 [166]	705 [320]	705 [320]
<b>Frame size</b>			FB	FB	FB	GB	GD

1) The base load current  $I_{HDC}$  is the basis for a duty cycle of duration 300 s with an overload of 150% x  $I_{HDC}$  for 60 s, or  $I_{maxDC}$  for 5 s.

2) The current demand for the 460 (400) V AC auxiliary power supply is drawn from the line input voltage.

3) The specified power loss represents the maximum value at 100 % utilization. The value is lower under normal operating conditions.

4) Sum of lengths of all motor cables and DC bus. Longer cable lengths for specific configurations may be available on request.

5) The enclosure height increases by 10" (250 mm) for NEMA 1 (IP21) and by 16" (400 mm) for NEMA 1 filtered (IP23), IP43 and NEMA ventilated (IP54) enclosure.

### Technical data

Line voltage 500 ... 600 (690) V 3 ph. AC Note: UL Listing is valid only for $\leq 600$ V		Basic Line Module					
		6SL3730-1TG33-0AU3	6SL3730-1TG34-3AU3	6SL3730-1TG36-8AU3	6SL3730-1TG41-1AU3	6SL3730-1TG41-4AU3	6SL3730-1TG41-8AU3
For parallel connection, mounted to the <u>left</u> of the Line Connection Module					6SL3730-1TG41-1CU3	6SL3730-1TG41-4CU3	6SL3730-1TG41-8CU3
<b>Rated power</b>							
• For $I_{NDC}$ (60 Hz, 575 V)	kW	200	300	450	750	900	1,250
• For $I_{NDC}$ (50 Hz, 690 V)	kW	250	355	560	900	1,100	1,500
• For $I_{HDC}$ (60 Hz, 575 V)	kW	150	250	355	600	750	1,000
• For $I_{HDC}$ (50 Hz, 690 V)	kW	195	280	440	710	910	1,220
<b>DC bus current</b>							
• Rated current $I_{NDC}$	A	300	430	680	1,100	1,400	1,880
• Base load current $I_{HDC}^{(1)}$	A	234	335	530	858	1,092	1,467
• Maximum current $I_{maxDC}$	A	450	645	1,020	1,650	2,100	2,820
<b>Input current</b>							
• Rated current $I_{NE}$	A	260	375	575	925	1,180	1,580
• Maximum current $I_{maxE}$	A	390	563	863	1,388	1,770	2,370
<b>Current demand</b>							
• 24V DC auxiliary power supply	A	1.1	1.1	1.1	1.1	1.1	1.1
• 575 (690) V AC <sup>2)</sup>	A	Internal	Internal	Internal	Internal	Internal	Internal
<b>DC bus capacitance</b>							
• Basic Line Module	$\mu$ F	3,200	4,800	7,300	11,600	15,470	19,500
• Drive line-up, max.	$\mu$ F	25,600	38,400	58,400	92,800	123,760	78,000
<b>Power loss, max. <sup>3)</sup></b>							
• At 60 Hz 460V [50 Hz 690V]	kW	1.5 [1.5]	2.1 [2.1]	3.0 [3.0]	5.4 [5.4]	5.8 [5.8]	7.3 [7.3]
<b>Cooling air requirement</b>		cfm [m <sup>3</sup> /s]	360 [0.17]	360 [0.17]	360 [0.17]	763 [0.36]	763 [0.36]
<b>Sound pressure level <math>L_{pA}</math> (1 m) at 60 [50] Hz</b>		dB(A)	68 [66]	68 [66]	68 [66]	73 [71]	73 [71]
<b>Output cable length, max. <sup>4)</sup></b>							
• Shielded	ft [m]	4,900 [1,500]	4,900 [1,500]	4,900 [1,500]	7,400 [2,250]	7,400 [2,250]	9,000 [2,750]
• Unshielded	ft [m]	7,400 [2,250]	7,400 [2,250]	7,400 [2,250]	11,000 [3,375]	11,000 [3,375]	13,500 [4,125]
<b>Enclosure (base design)</b>			IP20	IP20	IP20	IP20	IP20
<b>Enclosure dimensions, nominal</b>							
• Width	inch [mm]	16 [400]	16 [400]	16 [400]	16 [400]	16 [400]	16 [400]
• Height <sup>5)</sup>	inch [mm]	87 [2,200]	87 [2,200]	87 [2,200]	87 [2,200]	87 [2,200]	87 [2,200]
• Depth	inch [mm]	24 [600]	24 [600]	24 [600]	24 [600]	24 [600]	24 [600]
<b>Weight, approx.</b>		lb [kg]	366 [166]	366 [166]	366 [166]	705 [320]	705 [320]
<b>Frame size</b>			FB	FB	FB	GB	GD

1) The base load current  $I_{HDC}$  is the basis for a duty cycle of duration 300 s with an overload of  $150\% \times I_{HDC}$  for 60 s, or  $I_{maxDC}$  for 5 s.

2) The current demand for the 575 (690) V AC auxiliary power supply is drawn from the line input voltage.

3) The specified power loss represents the maximum value at 100% utilization. The value is lower under normal operating conditions.

4) Sum of lengths of all motor cables and DC bus. Longer cable lengths for specific configurations may be available on request.

5) The enclosure height increases by 10" (250 mm) for NEMA 1 (IP21) and by 16" (400 mm) for NEMA 1 filtered (IP23), IP43 and NEMA 12 ventilated (IP54) enclosure.

# SINAMICS S120 Cabinet Modules

## Basic Line Modules

### Options

The table below lists the available options for Basic Line Modules (refer to **Description of the Options** for details).

Available Options	Option code
CBC10 Communication Board (CANbus)	G20 <sup>1)</sup>
CBE20 Communication Board (Ethernet)	G33 <sup>1)</sup>
Monitoring of precharge function	G56
AOP30 Advanced Operator Panel installed in the cabinet door	K08 <sup>1)</sup>
CU320-2 DP Control Unit (PROFIBUS DP)	K90
Performance expansion for CU320-2	K94 <sup>1)</sup>
CU320-2 PN Control Unit (PROFINET)	K95
Enclosure space heater	L55
25/125 kW braking unit (for frame size FB) for line voltages of 380 ... 480 V and 660 ... 690 V	L61
50/250 kW braking unit (for frame size GB/GD) for line voltages of 380 ... 480 V and 660 ... 690 V	L62
25/125 kW braking unit (for frame size FB) for line voltages of 500 ... 600 V	L64
50/250 kW braking unit (for frame size GB/GD) for line voltages of 500 ... 600 V	L65
Base (plinth) 100mm	M06
Base (plinth) 200mm (cable marshalling space)	M07
Enclosure NEMA 1 (IP21)	M21
Enclosure NEMA 1 filtered (IP23) [includes M60]	M23
Side panel (right)	M26
Side panel (left)	M27
Enclosure IP43 [includes M60]	M43
Enclosure NEMA 12 (ventilated) (IP54) [includes M60]	M54
Solid cabinet door (no ventilation openings, air inlet through floor)	M59
Additional touch protection [included in M23, M43 & M54]	M60
DC busbar system ( $I_d = 1,170$ A, 1x 60 x 10 mm)	M80
DC busbar system ( $I_d = 1,500$ A, 1x 80 x 10 mm)	M81
DC busbar system ( $I_d = 1,840$ A, 1x 100 x 10 mm)	M82
DC busbar system ( $I_d = 2,150$ A, 2x 60 x 10 mm)	M83
DC busbar system ( $I_d = 2,730$ A, 2x 80 x 10 mm)	M84
DC busbar system ( $I_d = 3,320$ A, 2x 100 x 10 mm)	M85
DC busbar system ( $I_d = 3,720$ A, 3x 80 x 10 mm)	M86
DC busbar system ( $I_d = 4,480$ A, 3x 100 x 10 mm)	M87
Lifting beam/eye bolts	M90
UL listing per UL508A [requires M23, M43 or M54]	U90
cUL listing per UL508A for Canada [requires M23, M43 or M54, plus T58]	U91

Available Options	Option code
Special enclosure paint color [specify color]	Y09
Assembly into transport sections [specify sections]	Y11
1-line label for customer text, 40 x 80 mm [specify text]	Y31
2-line label for customer text, 40 x 180 mm [specify text]	Y32
4-line label for customer text, 40 x 180 mm [specify text]	Y33
Customer drawings in dxf format	D02
Advance copy of customer documentation (pdf)	D14
Documentation English/French	D58
Nameplate English/French	T58
Visual Inspection by customer	F03
Witnessed or observed function test without motor	F71
Witnessed or observed test incl. high-voltage and insulation test	F77
Customer specific test (on request)	F97

<sup>1)</sup> Only in combination with options K90 or K95.

### Options

#### Option combination matrix for Basic Line Modules

The following tables provide an overview of possible and impermissible combinations of standard options. Please refer to the descriptions of options for more information. Custom configurations may be possible to provide combinations not available as standard – please contact the factory.

- ✓ Combination is possible
- Combination is not possible

#### Electrical Options

	G20	G33	K08	K90	K94	K95	L61	L62	L64	L65
G20		–	✓	✓	✓	✓	✓	✓	✓	✓
G33	–		✓	✓	✓	✓	✓	✓	✓	✓
K08	✓	✓		✓	✓	✓	✓	✓	✓	✓
K90	✓	✓	✓		✓	–	✓	✓	✓	✓
K94	✓	✓	✓	✓		✓	✓	✓	✓	✓
K95	✓	✓	✓	–	✓		✓	✓	✓	✓
L61	✓	✓	✓	✓	✓	✓		–	–	–
L62	✓	✓	✓	✓	✓	✓	–		–	–
L64	✓	✓	✓	✓	✓	✓	–	–		–
L65	✓	✓	✓	✓	✓	✓	–	–	–	

#### Mechanical Options

	M06	M07	M21	M23	M43	M54	M59	M60	M90	Y11	U90	U91
M06		–	✓	✓	✓	✓	✓	✓	✓	✓	✓	✓
M07	–		✓	✓	✓	✓	✓	✓	✓	✓	✓	✓
M21	✓	✓		–	–	–	✓	✓	✓	✓	–	–
M23	✓	✓	–		–	–	✓	–	✓	✓	✓	✓
M43	✓	✓	–	–		–	✓	–	✓	✓	✓	✓
M54	✓	✓	–	–	–		✓	–	✓	✓	✓	✓
M59	✓	✓	✓	✓	✓	✓		✓	✓	✓	✓	✓
M60	✓	✓	✓	–	–	–	✓		✓	✓	–	–
M90	✓	✓	✓	✓	✓	✓	✓	✓		–	✓	✓
Y11	✓	✓	✓	✓	✓	✓	✓	✓	–		✓	✓
U90	✓	✓	–	✓	✓	✓	✓	–	✓	✓		–
U91	✓	✓	–	✓	✓	✓	✓	–	✓	✓	–	

# SINAMICS S120 Cabinet Modules

## Basic Line Modules

### Options

#### DC busbar system Options

Within a line-up, all DC bus needs to be of the same width (60, 80 or 100 mm). DC bus current ratings may vary within a line-up by using either a single busbar, or two or three busbars in parallel per pole.

The following table indicates which busbar options for the various cabinet modules may be combined within a line-up.



Combination is possible



Combination is not possible

	M80	M81	M82	M83	M84	M85	M86	M87
M80		-	-	✓	-	-	-	-
M81	-		-	-	✓	-	✓	-
M82	-	-		-	-	✓	-	✓
M83	✓	-	-		-	-	-	-
M84	-	✓	-	-		-	✓	-
M85	-	-	✓	-	-		-	✓
M86	-	✓	-	-	✓	-		-
M87	-	-	✓	-	-	✓	-	

#### Label Options

	Y31	Y32	Y33
Y31		-	-
Y32	-		-
Y33	-	-	

### Overview



Smart Line Modules are uncontrolled rectifiers that supply power from the AC supply to the DC bus, and that are also capable of regenerating 100% continuous power from the DC bus back to the line. Regeneration can be deactivated with a digital input.

The use of IGBTs makes Smart Line Modules immune to inverter commutation faults.

Smart Line Modules are available for the following voltages and currents. Power ratings can be increased by connecting up to four identical SLM in parallel.

Line voltage	Rated power
380 ... 480 V 3 ph. AC	250 ... 900 kW
500 ... 600 (690) V 3 ph. AC	400 (450) ... 1,150 (1,400) kW

A Smart Line Module is a 6-pulse front end. For low harmonic feedback it is possible to configure multiple Smart Line Modules in 12-, 18- or 24-pulse configurations in combination with phase shifting transformers. Note that commercially available line harmonic filters are not suitable for use with Smart Line Modules.

For Smart Line Modules the Line Connection Module includes a 4% line reactor as standard. If there is sufficient impedance on the line side (for example, when using a dedicated drive isolation transformer) the line reactor can be excluded (option L22). This option is not available for parallel Smart Line Modules connected to a single Line Connection Module, as line reactors are required to ensure current sharing.

For additional information, please refer to the [SINAMICS Low Voltage Engineering Manual](#).

### Design

Smart Line Modules are IGBT based inverters. When regenerating, the IGBTs are switched at the fundamental line frequency. Since this reduces switching losses, a high percentage of the power device current can be utilized. In rectifier mode the current flows through the freewheeling diodes of the IGBTs. The Smart Line Module thus behaves in a similar way to the Basic Line Module. If any of the loads in the line-up regenerate more power than can be absorbed by other loads, the DC bus voltage increases and the IGBTs are switched to feed the excess energy back into the supply system.

The precharge circuitry is built into Smart Line Modules, and the Line Connection Module with option L44 (LCM for Smart Line Module) includes the power supply for the precharge circuit, as well as a contactor or motorized circuit breaker to bypass (bridge) the precharge circuit after precharging the DC bus capacitors.

Braking Modules with associated braking resistors may be added. They would typically be needed only if it is necessary to brake the load in the event of a power supply failure.

#### *Parallel connection of Smart Line Modules to increase the power rating*

There are two alternative arrangements for connecting Smart Line Modules in parallel to obtain drive line-ups with a higher power rating, similar to the arrangements available for Basic Line Modules.

#### Two Smart Line Modules supplied with power via two separate Line Connection Modules

With this arrangement, each Smart Line Module is supplied by a Line Connection Module, which includes a circuit breaker disconnect and fuses. The Smart Line Module is always located to the right of the Line Connection Module, and has an order no. ending in "AU3", example: 6SL3730-6T...-AU3.

Smart Line Modules with their associated Line Connection Modules may be located anywhere in the line-up.

Note that for a line-up with multiple disconnects special lock out/tag out procedures may be required on site.

# SINAMICS S120 Cabinet Modules

## Smart Line Modules

### Design

Two Smart Line Modules supplied with power via a single Line Connection Module

In the alternative arrangement, two Smart Line Modules can be connected to the left and right of a single Line Connection Module, which results in a very compact design for the line infeed. The connections on the Smart Line Module on the left of the Line Connection Module are a mirror image of the standard unit mounted to its right.

For a parallel connection, the Smart Line Module to the right has an order no. ending in "BU3", while the one to the left has an order no. ending in "CU3."

The Line Connection Module for parallel connection includes a single circuit breaker with two sets of line fuses, for selective individual protection of each line module.

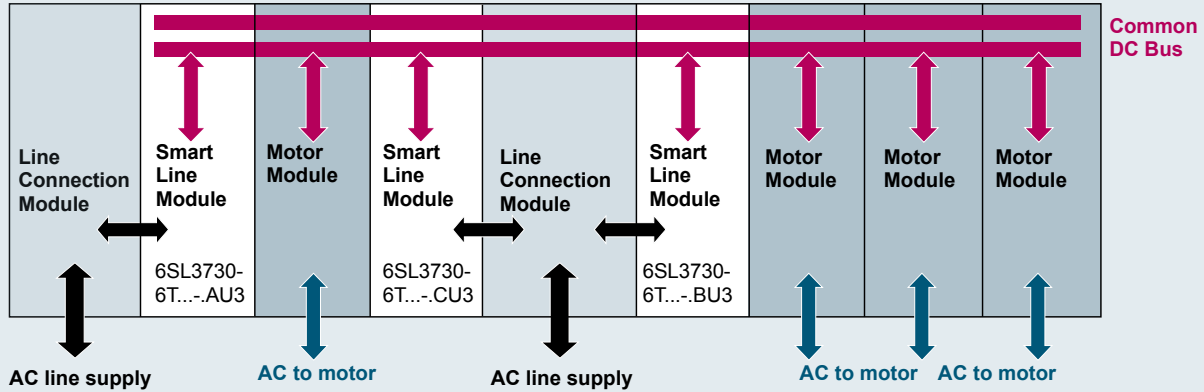

#### Note:

Please note that only Smart Line Modules with exactly the same output rating may be connected in parallel. Due to the possibility of unequal current sharing the rated current of the Smart Line Modules must be derated by 7.5%.

Smart Line Modules connected in parallel are operated on a common control unit, and the required DRIVE-CLiQ cables need to be considered.

For additional information, please refer to the SINAMICS Low Voltage Engineering Manual.

### Selection and ordering data

Rated power at 460 (400) V kW	Note for parallel connection Mounting relative to Line Connection Module	Smart Line Module Order No.
Line voltage 380 ... 480 V 3ph. AC (DC bus voltage 510 ... 650 V DC)		
300 (250)	–	6SL3730-6TE35-5AU3
400 (355)	–	6SL3730-6TE37-3AU3
560 (500)	–	6SL3730-6TE41-1AU3
	Right	6SL3730-6TE41-1BU3
	Left	6SL3730-6TE41-1CU3
710 (630)	–	6SL3730-6TE41-3AU3
	Right	6SL3730-6TE41-3BU3
	Left	6SL3730-6TE41-3CU3
900 (800)	–	6SL3730-6TE41-7AU3
	Right	6SL3730-6TE41-7BU3
	Left	6SL3730-6TE41-7CU3

Rated power at 575 (690) V kW	Note for parallel connection Mounting relative to Line Connection Module	Smart Line Module Order No.
Line voltage 500 ... 600 (690) V 3ph. AC (DC bus voltage 675 ... 810 (930) V DC)		
400 (450)	–	6SL3730-6TG35-5AU3
630 (710)	–	6SL3730-6TG38-8AU3
	Right	6SL3730-6TG38-8BU3
	Left	6SL3730-6TG38-8CU3
	800 (1,000)	–
Right		6SL3730-6TG41-2BU3
	Left	6SL3730-6TG41-2CU3
	1,200 (1,400)	–
Right		6SL3730-6TG41-7BU3
	Left	6SL3730-6TG41-7CU3



### Block diagram

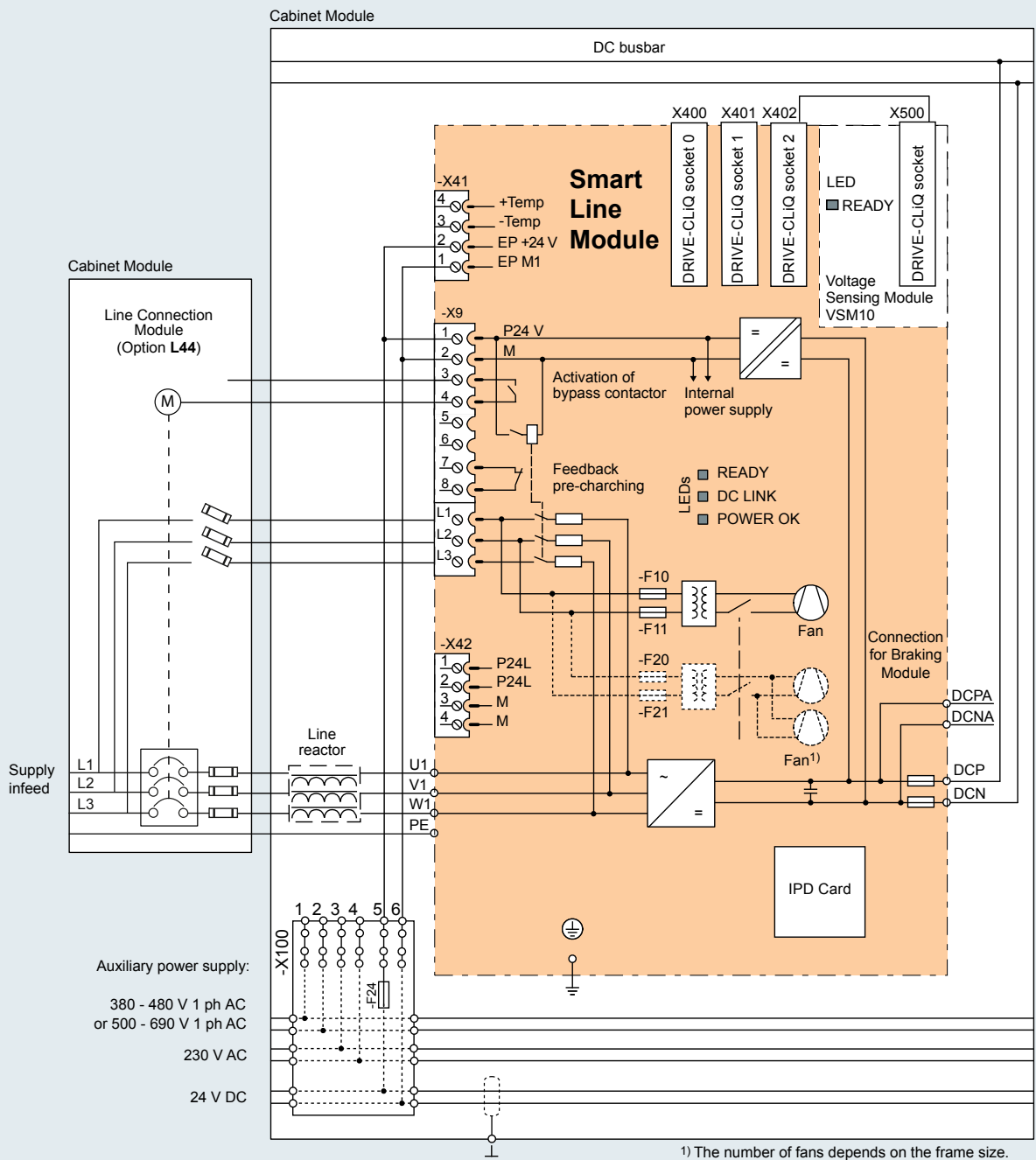

Connection example of a Smart Line Module

# SINAMICS S120 Cabinet Modules

## Smart Line Modules

### Technical data

Line Voltage 380 ... 480 V 3 ph. AC		Smart Line Module				
		6SL3730-6TE35-5AU3	6SL3730-6TE37-3AU3	6SL3730-6TE41-1AU3	6SL3730-6TE41-3AU3	6SL3730-6TE41-7AU3
For parallel connection, mounted to the <u>right</u> of the Line Connection Module				6SL3730-6TE41-1BU3	6SL3730-6TE41-3BU3	6SL3730-6TE41-7BU3
For parallel connection, mounted to the <u>left</u> of the Line Connection Module				6SL3730-6TE41-1CU3	6SL3730-6TE41-3CU3	6SL3730-6TE41-7CU3
<b>Rated power</b>						
• For $I_{N\ DC}$ (60 Hz, 460 V)	kW	300	400	560	710	900
• For $I_{N\ DC}$ (50 Hz, 400 V)	kW	250	355	500	630	800
• For $I_{H\ DC}$ (60 Hz, 460 V)	kW	250	355	500	630	800
• For $I_{H\ DC}$ (50 Hz, 400 V)	kW	235	315	450	555	730
<b>DC bus current</b>						
• Rated current $I_{N\ DC}$	A	550	730	1,050	1,300	1,700
• Base load current $I_{H\ DC}$ <sup>1)</sup>	A	490	650	934	1,157	1,513
• Maximum current $I_{max\ DC}$	A	825	1,095	1,575	1,950	2,550
<b>Input current</b>						
• Rated current $I_{NE}$	A	463	614	883	1,093	1,430
• Maximum current $I_{max\ E}$	A	694	921	1,324	1,639	2,145
<b>Current demand</b>						
• 24V DC auxiliary power supply	A	1.35	1.35	1.4	1.5	1.7
• 460 (400) V AC <sup>2)</sup>	A	1.8	1.8	3.6	5.4	5.4
<b>DC bus capacitance</b>						
• Smart Line Module	μF	8,400	12,000	16,800	18,900	28,800
• Drive line-up, max.	μF	42,000	60,000	67,200	75,600	115,200
<b>Power loss, max. <sup>3)</sup></b>						
• At 60 Hz 460V [50 Hz 400V]	kW	3.7	4.7	7.1	11.0	11.5
<b>Cooling air requirement</b>		cfm [m <sup>3</sup> /s]	763 [0.36]	763 [0.36]	1,650 [0.78]	2,290 [1.08]
<b>Sound pressure level <math>L_{pA}</math> (1m) at 60 [50] Hz</b>		dB(A)	73 [69]	73 [69]	73 [70]	73 [70]
<b>Output cable length, max. <sup>4)</sup></b>						
• Shielded	ft [m]	13,100 [4,000]	13,100 [4,000]	15,750 [4,800]	15,750 [4,800]	15,750 [4,800]
• Unshielded	ft [m]	19,700 [6,000]	19,700 [6,000]	23,600 [7,200]	23,600 [7,200]	23,600 [7,200]
<b>Enclosure (base design)</b>			IP20	IP20	IP20	IP20
<b>Enclosure dimensions, nominal</b>						
• Width	inch [mm]	16 [400]	16 [400]	24 [600]	31.5 [800]	31.5 [800]
• Height <sup>5)</sup>	inch [mm]	87 [2,200]	87 [2,200]	87 [2,200]	87 [2,200]	87 [2,200]
• Depth	inch [mm]	24 [600]	24 [600]	24 [600]	24 [600]	24 [600]
<b>Weight, approx.</b>		lb [kg]	600 [270]	600 [270]	1,080 [490]	1,710 [775]
<b>Frame size</b>			GX	GX	HX	JX

1) The base load current  $I_{H\ DC}$  is the basis for a duty cycle of duration 300 s with an overload of 150% x  $I_{H\ DC}$  for 60 s, or  $I_{max\ DC}$  for 5 s.

2) The current demand for the 460 (400) V AC auxiliary power supply is drawn from the line input voltage.

3) The specified power loss represents the maximum value at 100 % utilization. The value is lower under normal operating conditions.

4) Sum of lengths of all motor cables and DC bus. Longer cable lengths for specific configurations may be available on request..

5) The enclosure height increases by 10" (250 mm) for NEMA 1 (IP21) and by 16" (400 mm) for NEMA 1 filtered (IP23), IP43 and NEMA 12 ventilated (IP54) enclosure.

### Technical data

Line Voltage 500 ... 600 (690) V 3 ph. AC Note: UL Listing is valid only for ≤ 600 V		Smart Line Module			
		6SL3730-6TG35-5AU3	6SL3730-6TG38-8AU3	6SL3730-6TG41-2AU3	6SL3730-6TG41-7AU3
For parallel connection, mounted to the <u>right</u> of the Line Connection Module			6SL3730-6TG38-8BU3	6SL3730-6TG41-2BU3	6SL3730-6TG41-7BU3
For parallel connection, mounted to the <u>left</u> of the Line Connection Module			6SL3730-6TG38-8CU3	6SL3730-6TG41-2CU3	6SL3730-6TG41-7CU3
<b>Rated power</b>					
• For $I_{NDC}$ (60 Hz, 575 V)	kW	400	630	800	1,200
• For $I_{NDC}$ (50 Hz, 690 V)	kW	450	710	1,000	1,400
• For $I_{HDC}$ (60 Hz, 575 V)	kW	350	560	710	1,000
• For $I_{HDC}$ (50 Hz, 690 V)	kW	405	665	885	1,255
<b>DC bus current</b>					
• Rated current $I_{NDC}$	A	550	900	1,200	1,700
• Base load current $I_{HDC}^{1)}$	A	490	800	1,068	1,513
• Maximum current $I_{maxDC}$	A	825	1,350	1,800	2,550
<b>Input current</b>					
• Rated current $I_{NE}$	A	463	757	1,009	1,430
• Maximum current $I_{maxE}$	A	694	1,135	1,513	2,145
<b>Current demand</b>					
• 24V DC auxiliary power supply	A	1.35	1.4	1.5	1.7
• 575 (690) V AC <sup>2)</sup>	A	1.2 [1.0]	2.5 [2.1]	3.7 [3.1]	3.7 [3.1]
<b>DC bus capacitance</b>					
• Smart Line Module	μF	5,600	7,400	11,100	14,400
• Drive line-up, max.	μF	28,000	29,600	44,400	57,600
<b>Power loss, max.<sup>3)</sup></b>					
• At 60 Hz 575V [50 Hz 690V]	kW	4.3	6.5	12.0	13.8
<b>Cooling air requirement</b>		cfm [m <sup>3</sup> /s]	763 [0.36]	1,650 [0.78]	2,290 [1.08]
<b>Sound pressure level <math>L_{pA}</math> (1 m) at 60 [50] Hz</b>		dB(A)	73 [69]	73 [70]	73 [70]
<b>Output cable length, max. <sup>4)</sup></b>					
• Shielded	ft [m]	7,400 [2,250]	9,000 [2,750]	9,000 [2,750]	9,000 [2,750]
• Unshielded	ft [m]	11,000 [3,375]	13,500 [4,125]	13,500 [4,125]	13,500 [4,125]
<b>Enclosure (base design)</b>			IP20	IP20	IP20
<b>Enclosure dimensions, nominal</b>					
• Width	inch [mm]	16 [400]	24 [600]	31.5 [800]	31.5 [800]
• Height <sup>5)</sup>	inch [mm]	87 [2,200]	87 [2,200]	87 [2,200]	87 [2,200]
• Depth	inch [mm]	24 [600]	24 [600]	24 [600]	24 [600]
<b>Weight, approx.</b>	lb [kg]	600 [270]	1,210 [550]	1,750 [795]	1,750 [795]
<b>Frame size</b>		GX	HX	JX	JX

1) The base load current  $I_{HDC}$  is the basis for a duty cycle of duration 300 s with an overload of 150% x  $I_{HDC}$  for 60 s, or  $I_{maxDC}$  for 5 s.

2) The current demand for the 575 (690) V AC auxiliary power supply is drawn from the line input voltage.

3) The specified power loss represents the maximum value at 100 % utilization. The value is lower under normal operating conditions.

4) Sum of lengths of all motor cables and DC bus. Longer cable lengths for specific configurations may be available on request..

5) The enclosure height increases by 10" (250 mm) for NEMA 1 (IP21) and by 16" (400 mm) for NEMA 1 filtered (IP23), IP43 and NEMA 12 ventilated (IP54) enclosure.

# SINAMICS S120 Cabinet Modules

## Smart Line Modules

### Options

The table below lists the available options for Smart Line Modules (refer to **Description of the Options** for details).

Available Options	Option code	Available Options	Option code
CBC10 Communication Board (CANbus)	<b>G20</b> <sup>1)</sup>	Special enclosure paint color [specify color]	<b>Y09</b>
CBE20 Communication Board (Ethernet)	<b>G33</b> <sup>1)</sup>	Assembly into transport sections [specify sections]	<b>Y11</b>
Monitoring of precharge function	<b>G56</b>	1-line label for customer text, 40 x 80 mm [specify text]	<b>Y31</b>
AOP30 Advanced Operator Panel installed in the cabinet door	<b>K08</b> <sup>1)</sup>	2-line label for customer text, 40 x 180 mm [specify text]	<b>Y32</b>
CU320-2 DP Control Unit (PROFIBUS DP)	<b>K90</b>	4-line label for customer text, 40 x 180 mm [specify text]	<b>Y33</b>
Performance expansion for CU320-2	<b>K94</b> <sup>1)</sup>	Customer drawings in dxf format	<b>D02</b>
CU320-2 PN Control Unit (PROFINET)	<b>K95</b>	Advance copy of customer documentation (pdf)	<b>D14</b>
Without input line reactor	<b>L22</b>	Documentation English/French	<b>D58</b>
Enclosure space heater	<b>L55</b>	Nameplate English/French	<b>T58</b>
50/250 kW braking unit for line voltages of 380 ... 480 V and 660 ... 690 V	<b>L62</b>	Visual Inspection by customer	<b>F03</b>
50/250 kW braking unit for line voltages of 500 ... 600 V	<b>L65</b>	Witnessed or observed function test without motor	<b>F71</b>
Base (plinth) 100mm	<b>M06</b>	Witnessed or observed test incl. high-voltage and insulation test	<b>F77</b>
Base (plinth) 200mm (cable marshalling space)	<b>M07</b>	Customer specific test (on request)	<b>F97</b>
Enclosure NEMA 1 (IP21)	<b>M21</b>		
Enclosure NEMA 1 filtered (IP23) [includes M60]	<b>M23</b>		
Side panel (right)	<b>M26</b>		
Side panel (left)	<b>M27</b>		
Enclosure IP43 [includes M60]	<b>M43</b>		
Enclosure NEMA 12 (ventilated) (IP54) [includes M60]	<b>M54</b>		
Solid cabinet door (no ventilation openings, air inlet through floor)	<b>M59</b>		
Additional touch protection [included in <b>M23</b> , <b>M43</b> & <b>M54</b> ]	<b>M60</b>		
DC busbar system ( $I_g = 1,170$ A, 1x 60 x 10 mm)	<b>M80</b>		
DC busbar system ( $I_g = 1,500$ A, 1x 80 x 10 mm)	<b>M81</b>		
DC busbar system ( $I_g = 1,840$ A, 1x 100 x 10 mm)	<b>M82</b>		
DC busbar system ( $I_g = 2,150$ A, 2x 60 x 10 mm)	<b>M83</b>		
DC busbar system ( $I_g = 2,730$ A, 2x 80 x 10 mm)	<b>M84</b>		
DC busbar system ( $I_g = 3,320$ A, 2x 100 x 10 mm)	<b>M85</b>		
DC busbar system ( $I_g = 3,720$ A, 3x 80 x 10 mm)	<b>M86</b>		
DC busbar system ( $I_g = 4,480$ A, 3x 100 x 10 mm)	<b>M87</b>		
Lifting beam/eye bolts	<b>M90</b>		
UL listing per UL508A [requires <b>M23</b> , <b>M43</b> or <b>M54</b> ]	<b>U90</b>		
cUL listing per UL508A for Canada [requires <b>M23</b> , <b>M43</b> or <b>M54</b> , plus <b>T58</b> ]	<b>U91</b>		

1) Only in combination with options **K90** or **K95**.

### Options

#### Option combination matrix for Smart Line Modules

The following tables provide an overview of possible and impermissible combinations of standard options. Please refer to the descriptions of options for more information. Custom configurations may be possible to provide combinations not available as standard – please contact the factory.

✓ Combination is possible

– Combination is not possible

#### Electrical Options

	G20	G33	K08	K90	K94	K95	L22	L62	L65
G20		–	✓	✓	✓	✓	✓	✓	✓
G33	–		✓	✓	✓	✓	✓	✓	✓
K08	✓	✓		✓	✓	✓	✓	✓	✓
K90	✓	✓	✓		✓	–	✓	✓	✓
K94	✓	✓	✓	✓		✓	✓	✓	✓
K95	✓	✓	✓	–	✓		✓	✓	✓
L22	✓	✓	✓	✓	✓	✓		✓	✓
L62	✓	✓	✓	✓	✓	✓	✓		–
L65	✓	✓	✓	✓	✓	✓	✓	–	

#### Mechanical Options

	M06	M07	M21	M23	M43	M54	M59	M60	M90	Y11	U90	U91
M06		–	✓	✓	✓	✓	✓	✓	✓	✓	✓	✓
M07	–		✓	✓	✓	✓	✓	✓	✓	✓	✓	✓
M21	✓	✓		–	–	–	✓	✓	✓	✓	–	–
M23	✓	✓	–		–	–	✓	–	✓	✓	✓	✓
M43	✓	✓	–	–		–	✓	–	✓	✓	✓	✓
M54	✓	✓	–	–	–		✓	–	✓	✓	✓	✓
M59	✓	✓	✓	✓	✓	✓		✓	✓	✓	✓	✓
M60	✓	✓	✓	–	–	–	✓		✓	✓	–	–
M90	✓	✓	✓	✓	✓	✓	✓	✓		–	✓	✓
Y11	✓	✓	✓	✓	✓	✓	✓	✓	–		✓	✓
U90	✓	✓	–	✓	✓	✓	✓	–	✓	✓		–
U91	✓	✓	–	✓	✓	✓	✓	–	✓	✓	–	

# SINAMICS S120 Cabinet Modules

## Smart Line Modules

### Options

#### DC busbar system Options

Within a line-up, all DC bus needs to be of the same width (60, 80 or 100 mm). DC bus current ratings may vary within a line-up by using either a single busbar, or two or three busbars in parallel per pole.

The following table indicates which busbar options for the various cabinet modules may be combined within a line-up.



Combination is possible



Combination is not possible

	M80	M81	M82	M83	M84	M85	M86	M87
M80		-	-	✓	-	-	-	-
M81	-		-	-	✓	-	✓	-
M82	-	-		-	-	✓	-	✓
M83	✓	-	-		-	-	-	-
M84	-	✓	-	-		-	✓	-
M85	-	-	✓	-	-		-	✓
M86	-	✓	-	-	✓	-		-
M87	-	-	✓	-	-	✓	-	

#### Label Options

	Y31	Y32	Y33
Y31		-	-
Y32	-		-
Y33	-	-	

### Overview



Active Line Modules are controlled rectifiers that supply power from the AC supply to the DC bus, and that are also capable of regenerating 100% continuous power from the DC bus back to the line.

In contrast to Basic Line Modules and Smart Line Modules, Active Line Modules control the DC bus voltage and keep it constant despite fluctuations in the line voltage (the line voltage must remain within the permissible tolerance range).

Braking Modules with associated braking resistors may be added. They would typically be needed only if it is necessary to brake the load in the event of a power supply failure.

Active Line Modules are available for the following voltages and currents. Power ratings can be increased by connecting up to four identical Active Line Modules in parallel.

Line voltage	Rated power
380 ... 480 V 3 ph. AC	132 ... 1,000 kW
500 ... 600 (690) V 3 ph. AC	400 (560) ... 1,150 (1,400) kW

Active Line Modules draw a virtually sinusoidal current from the supply system with very low current harmonics that meet the requirements of IEEE 519-1992 at the drive input terminals. In addition, Active Line Modules allow the input power to be adjusted within the range of approx. 0.80 leading to 0.80 lagging (default setting is unity power factor).

For additional information, please refer to the [SINAMICS Low Voltage Engineering Manual](#).

### Design

Active Line Modules are always operated together with an Active Interface Module, which contains the associated Clean Power Filter and pre-charging circuit. The integrated line filter ensures compliance with the EMC requirements for the "second environment".

The Active Line Module and Active Interface Module are supplied as a complete, fully wired unit, i.e., the customer does not need to supply any further cables or carry out any other wiring tasks.

The precharge circuitry is built into Active Line Modules, and the Line Connection Module with option L42 (for Active Line Module) may, depending on the power rating, include the power supply for the precharge circuit, as well as a contactor or motorized circuit breaker to bypass (bridge) the precharge circuit after precharging the DC bus capacitors.

#### **Parallel connection of Active Line Modules to increase the power rating**

There are two alternative arrangements for connecting Active Line Modules in parallel to obtain drive line-ups with a higher power rating.

##### Two Active Line Modules supplied with power via two separate Line Connection Modules

With this arrangement, each Active Line Module is supplied by a Line Connection Module, which includes a circuit breaker disconnect and fuses. The Active Line Module is always located to the right of the Line Connection Module, and has an order no. ending in "AU3", example: 6SL3730-7T...-AU3.

Active Line Modules with their associated Line Connection Modules may be located anywhere in the line-up.

Note that for a line-up with multiple disconnects special lock out/tag out procedures may be required on site.

# SINAMICS S120 Cabinet Modules

## Active Line Modules

### Design

#### Two Active Line Modules supplied with power via a single Line Connection Module

In the alternative arrangement, two Active Line Modules can be connected to the left and right of a single Line Connection Module, which results in a very compact design for the line infeed. The power connections on the Active Line Module on the left of the Line Connection Module are a mirror image of the standard unit mounted to its right.

For a parallel connection, the Active Line Module to the left has an order no. ending in "CU3."

The Line Connection Module for parallel connection includes a single circuit breaker with two sets of line fuses, for selective individual protection of each line module.

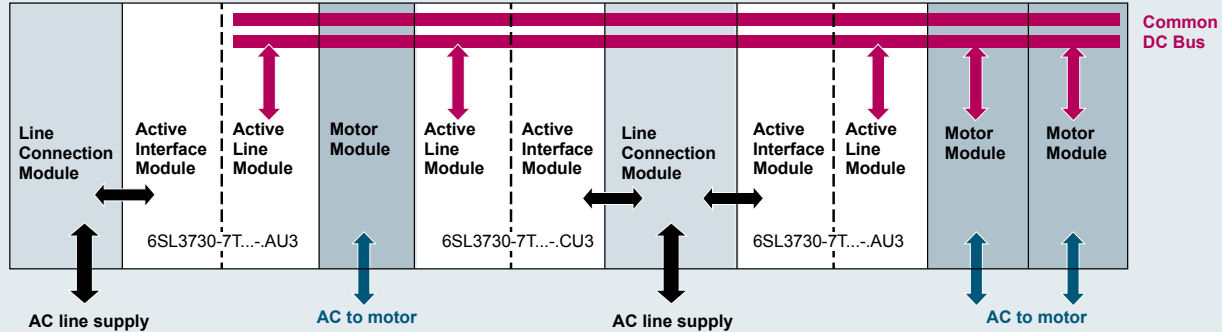

#### Note:

Please note that only Active Line Modules with exactly the same output rating may be connected in parallel. Due to the possibility of unequal current sharing the rated current of the Active Line Modules must be derated by 5%.

Active Line Modules connected in parallel are operated on a common control unit, and the required DRIVE-CLiQ cables need to be considered.

For additional information, please refer to the [SINAMICS Low Voltage Engineering Manual](#).

### Selection and ordering guide

Rated power at 460 (400) V kW	Note for parallel connection Mounting relative to Line Connection Module	Active Line Module Order No.
Line voltage 380 ... 480 V 3ph. AC (DC bus voltage 540 ... 720 V DC)		
150 (132)	–	6SL3730-7TE32-1AU3
180 (160)	–	6SL3730-7TE32-6AU3
270 (235)	–	6SL3730-7TE33-8AU3
350 (300)	–	6SL3730-7TE35-0AU3
450 (380)	–	6SL3730-7TE36-1AU3
560 (500)	–	6SL3730-7TE38-4AU3
710 (630)	–	6SL3730-7TE41-0AU3
	Left	6SL3730-7TE41-0CU3
1,000 (900)	–	6SL3730-7TE41-4AU3
	Left	6SL3730-7TE41-4CU3

Rated power at 575 (690) V kW	Note for parallel connection Mounting relative to Line Connection Module	Active Line Module Order No.
Line voltage 500 ... 600 (690) V 3ph. AC (DC bus voltage 700 ... 900 (1035) V DC)		
450 (560)	–	6SL3730-7TG35-8AU3
630 (800)	–	6SL3730-7TG37-4AU3
	Left	6SL3730-7TG37-4CU3
900 (1,100)	–	6SL3730-7TG41-0AU3
	Left	6SL3730-7TG41-0CU3
1,200 (1,400)	–	6SL3730-7TG41-3AU3
	Left	6SL3730-7TG41-3CU3



### Block diagram

The Active Line Module is controlled by the CU320-2 Control Unit. Communication between the Control Unit and module is established via DRIVE-CLiQ connections. The Active Interface Module is included in the scope of delivery of the Active Line Module.

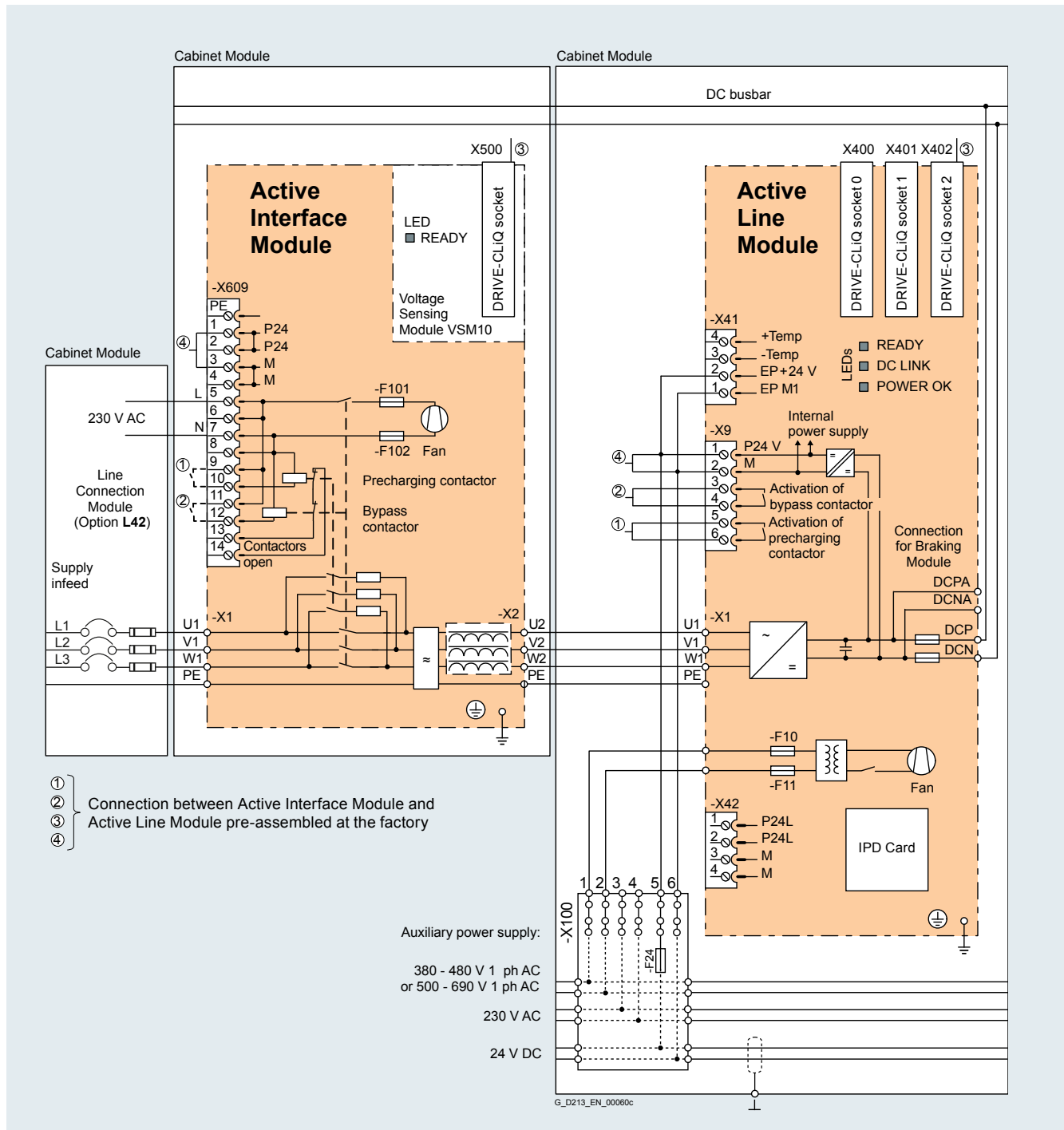

Connection example of an Active Line Module (frame size FI/FX and GI/GX)

# SINAMICS S120 Cabinet Modules

## Active Line Modules

### Block diagram

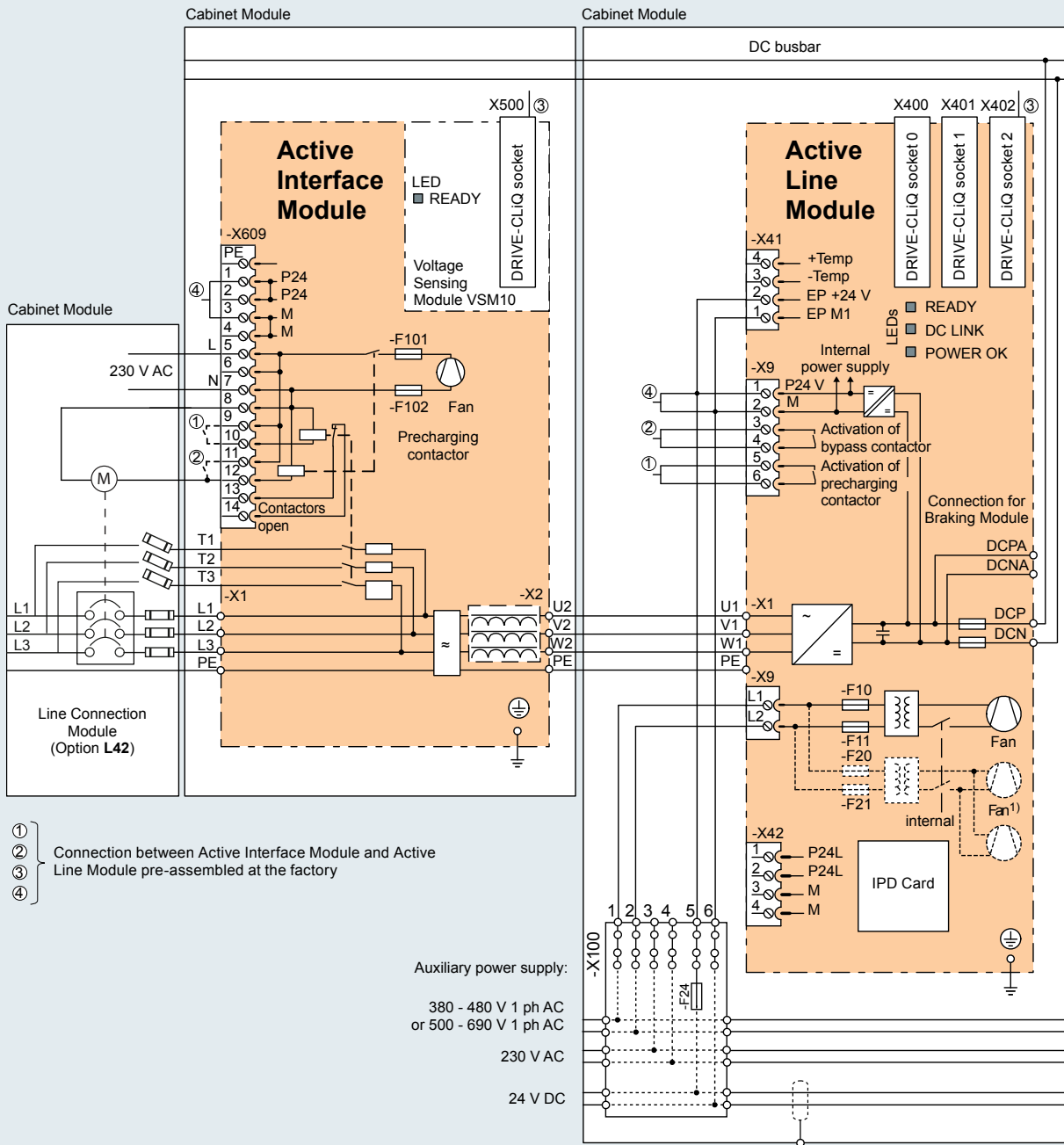

Connection example of an Active Line Module (frame size HII/HX and JII/JX)

### Technical data

Line Voltage 380 ... 480 V 3 ph. AC		Active Line Module			
		6SL3730-7TE32-1AU3	6SL3730-7TE32-6AU3	6SL3730-7TE33-8AU3	6SL3730-7TE35-0AU3
<b>Rated power</b>					
• For $I_{NDC}$ (60 Hz, 460 V)	kW	150	180	270	350
• For $I_{NDC}$ (50 Hz, 400 V)	kW	132	160	235	300
• For $I_{HDC}$ (60 Hz, 460 V)	kW	132	160	235	300
• For $I_{HDC}$ (50 Hz, 400 V)	kW	115	145	210	270
<b>DC bus current</b>					
• Rated current $I_{NDC}$	A	235	291	425	549
• Base load current $I_{HDC}^{1)}$	A	209	259	378	489
• Maximum current $I_{maxDC}$	A	352	436	637	823
<b>Input current</b>					
• Rated current $I_{NE}$	A	210	260	380	490
• Maximum current $I_{maxE}$	A	315	390	570	735
<b>Current demand</b>					
• 24V DC auxiliary power supply	A	1.27	1.27	1.52	1.52
• 230V AC auxiliary power supply		0.6	0.6	1.2	1.2
• 460 (400) V AC <sup>2)</sup>	A	0.63	1.13	1.8	1.8
<b>DC bus capacitance</b>					
• Basic Line Module	μF	4,200	5,200	7,800	9,600
• Drive line-up, max.	μF	41,600	41,600	76,800	76,800
<b>Power loss, max. <sup>3)</sup></b>					
• At 60 Hz 460V [50 Hz 400V]	kW	4.4 [4.3]	5.1 [4.9]	7.2 [6.9]	9.0 [8.7]
<b>Cooling air requirement</b>		cfm [m <sup>3</sup> /s]	1,380 [0.65]	1,380 [0.65]	2,760 [1.3]
<b>Sound pressure level <math>L_{pA}^{4)}</math> at 60 [50] Hz</b>		dB(A)	73 [71]	73 [71]	74 [72]
<b>Output cable length, max. <sup>5)</sup></b>					
• Shielded	ft [m]	8,860 [2,700]	8,860 [2,700]	8,860 [2,700]	8,860 [2,700]
• Unshielded	ft [m]	13,300 [4,050]	13,300 [4,050]	13,300 [4,050]	13,300 [4,050]
<b>Enclosure (base design)</b>			IP20	IP20	IP20
<b>Enclosure dimensions</b>					
• Width	inch [mm]	31.5 [800]	31.5 [800]	31.5 [800]	31.5 [800]
• Height <sup>6)</sup>	inch [mm]	87 [2,200]	87 [2,200]	87 [2,200]	87 [2,200]
• Depth	inch [mm]	24 [600]	24 [600]	24 [600]	24 [600]
<b>Weight, approx.</b>		lb [kg]	840 [380]	840 [380]	1,170 [530]
<b>Frame size (ALM + AIM)</b>			FX + FI	FX + FI	GX + GI

1) The base load current  $I_{HDC}$  is the basis for a duty cycle of duration 300 s with an overload of 150% x  $I_{HDC}$  for 60 s, or  $I_{maxDC}$  for 5 s.

2) The current demand for the 460 (400) V AC auxiliary power supply is drawn from the line input voltage.

3) The specified power loss represents the maximum value at 100 % utilization. The value is lower under normal operating conditions.

4) Total sound pressure level of Active Interface Module and Active Line Module combined.

5) Sum of lengths of all motor cables and DC bus. Longer cable lengths for specific configurations may be available on request..

6) The enclosure height increases by 10" (250 mm) for NEMA 1 (IP21) and by 16" (400 mm) for NEMA 1 filtered (IP23), IP43 and NEMA 12 ventilated (IP54) enclosure.

# SINAMICS S120 Cabinet Modules

## Active Line Modules

### Technical data

Line Voltage 380 ... 480 V 3 ph. AC		Active Line Module			
		6SL3730-7TE36-1AU3	6SL3730-7TE38-4AU3	6SL3730-7TE41-0AU3	6SL3730-7TE41-4AU3
For parallel connection, mounted to the <u>left</u> of the Line Connection Module				6SL3730-7TE41-0CU3	6SL3730-7TE41-4CU3
<b>Rated power</b>					
• For $I_{N\ DC}$ (60 Hz, 460 V)	kW	450	560	710	1,000
• For $I_{N\ DC}$ (50 Hz, 400 V)	kW	380	500	630	900
• For $I_{H\ DC}$ (60 Hz, 460 V)	kW	380	500	630	900
• For $I_{H\ DC}$ (50 Hz, 400 V)	kW	335	465	545	780
<b>DC bus current</b>					
• Rated current $I_{N\ DC}$	A	678	940	1,103	1,574
• Base load current $I_{H\ DC}$ 1)	A	603	837	982	1,404
• Maximum current $I_{max\ DC}$	A	1,017	1,410	1,654	2,361
<b>Input current</b>					
• Rated current $I_{NE}$	A	605	840	985	1,405
• Maximum current $I_{max\ E}$	A	907	1,260	1,477	2,107
<b>Current demand</b>					
• 24V DC auxiliary power supply	A	1.57	1.57	1.67	1.67
• 230V AC auxiliary power supply		4.6	4.6	4.9	4.9
• 460 (400) V AC 2)	A	3.6	3.6	5.4	5.4
<b>DC bus capacitance</b>					
• Basic Line Module	μF	12,600	16,800	18,900	28,800
• Drive line-up, max.	μF	134,400	134,400	230,400	230,400
<b>Power loss, max.</b> 3)					
• At 60 Hz 460V [50 Hz 400V]	kW	12.1 [11.7]	14.3 [13.8]	18.3 [17.6]	22.7 [21.8]
<b>Cooling air requirement</b>		cfm [m³/s]	3,350 [1.58]	3,350 [1.58]	4,000 [1.88]
<b>Sound pressure level <math>L_{pA}</math></b> 4) at 60 [50] Hz		dB(A)	79 [77]	79 [77]	80 [78]
<b>Output cable length, max.</b> 5)					
• Shielded	ft [m]	12,800 [3,900]	12,800 [3,900]	12,800 [3,900]	12,800 [3,900]
• Unshielded	ft [m]	19,200 [5,850]	19,200 [5,850]	19,200 [5,850]	19,200 [5,850]
<b>Enclosure (base design)</b>			IP20	IP20	IP20
<b>Enclosure dimensions</b>					
• Width	inch [mm]	39.4 [1,000]	39.4 [1,000]	55.1 [1,400]	55.1 [1,400]
• Height 6)	inch [mm]	87 [2,200]	87 [2,200]	87 [2,200]	87 [2,200]
• Depth	inch [mm]	24 [600]	24 [600]	24 [600]	24 [600]
<b>Weight, approx.</b>		lb [kg]	2,050 [930]	2,050 [930]	3,000 [1,360]
<b>Frame size (ALM + AIM)</b>			HX + HI	HX + HI	JX + JI

1) The base load current  $I_{H\ DC}$  is the basis for a duty cycle of duration 300 s with an overload of 150% x  $I_{H\ DC}$  for 60 s, or  $I_{max\ DC}$  for 5 s.

2) The current demand for the 460 (400) V AC auxiliary power supply is drawn from the line input voltage.

3) The specified power loss represents the maximum value at 100 % utilization. The value is lower under normal operating conditions.

4) Total sound pressure level of Active Interface Module and Active Line Module combined.

5) Sum of lengths of all motor cables and DC bus. Longer cable lengths for specific configurations may be available on request..

6) The enclosure height increases by 10" (250 mm) for NEMA 1 (IP21) and by 16" (400 mm) for NEMA 1 filtered (IP23), IP43 and NEMA 12 ventilated (IP54) enclosure.

### Technical data

Line Voltage 500 ... 600 (690) V 3 ph. AC Note: UL Listing is valid only for ≤600 V		Active Line Module			
		6SL3730-7TG35-8AU3	6SL3730-7TG37-4AU3	6SL3730-7TG41-0AU3	6SL3730-7TG41-3AU3
For parallel connection, mounted to the <u>left</u> of the Line Connection Module			6SL3730-7TG37-4CU3	6SL3730-7TG41-0CU3	6SL3730-7TG41-3CU3
<b>Rated power</b>					
• For $I_{N\ DC}$ (60 Hz, 575 V)	kW	450	630	900	1,200
• For $I_{N\ DC}$ (50 Hz, 690 V)	kW	560	800	1,100	1,400
• For $I_{H\ DC}$ (60 Hz, 575 V)	kW	450	560	800	1,000
• For $I_{H\ DC}$ (50 Hz, 690 V)	kW	550	705	980	1,215
<b>DC bus current</b>					
• Rated current $I_{N\ DC}$	A	644	823	1,148	1,422
• Base load current $I_{H\ DC}^{1)}$	A	573	732	1,022	1,266
• Maximum current $I_{max\ DC}$	A	966	1,234	1,722	2,133
<b>Input current</b>					
• Rated current $I_{NE}$	A	575	735	1,025	1,270
• Maximum current $I_{max\ E}$	A	862	1,102	1,537	1,905
<b>Current demand</b>					
• 24V DC auxiliary power supply	A	1.57	1.67	1.87	1.87
• 230V AC auxiliary power supply		4.6	4.9	4.9	4.9
• 575 (690) V AC <sup>2)</sup>	A	2.6 [2.1]	3.8 [3.1]	3.8 [3.1]	3.8 [3.1]
<b>DC bus capacitance</b>					
• Basic Line Module	μF	7,400	11,100	14,400	19,200
• Drive line-up, max.	μF	59,200	153,600	153,600	153,600
<b>Power loss, max. <sup>3)</sup></b>					
• At 60 Hz 575V [50 Hz 690V]	kW	13.0 [13.6]	18.6 [19.2]	22.1 [22.8]	24.9 [26.1]
<b>Cooling air requirement</b>		cfm [m <sup>3</sup> /s]	3,350 [1.58]	4,000 [1.88]	4,000 [1.88]
<b>Sound pressure level <math>L_{pA}^{4)}</math> (1M) at 60 [50] Hz</b>		dB(A)	79 [77]	79 [77]	79 [77]
<b>Output cable length, max. <sup>5)</sup></b>					
• Shielded	ft [m]	7,400 [2,250]	7,400 [2,250]	7,400 [2,250]	7,400 [2,250]
• Unshielded	ft [m]	11,100 [3,375]	11,100 [3,375]	11,100 [3,375]	11,100 [3,375]
<b>Enclosure (base design)</b>			IP20	IP20	IP20
<b>Enclosure dimensions</b>					
• Width	inch [mm]	39.4 [1,000]	55.1 [1,400]	55.1 [1,400]	55.1 [1,400]
• Height <sup>6)</sup>	inch [mm]	87 [2,200]	87 [2,200]	87 [2,200]	87 [2,200]
• Depth	inch [mm]	24 [600]	24 [600]	24 [600]	24 [600]
<b>Weight, approx.</b>		lb [kg]	2,050 [930]	3,000 [1,360]	3,000 [1,360]
<b>Frame size</b>			HX + HI	JX + JI	JX + JI

1) The base load current  $I_{H\ DC}$  is the basis for a duty cycle of duration 300 s with an overload of 150% x  $I_{H\ DC}$  for 60 s, or  $I_{max\ DC}$  for 5 s.

2) The current demand for the 575 (690) V AC auxiliary power supply is drawn from the line input voltage.

3) The specified power loss represents the maximum value at 100 % utilization. The value is lower under normal operating conditions.

4) Total sound pressure level of Active Interface Module and Active Line Module combined.

5) Sum of lengths of all motor cables and DC bus. Longer cable lengths for specific configurations may be available on request..

6) The enclosure height increases by 10" (250 mm) for NEMA 1 (IP21) and by 16" (400 mm) for NEMA 1 filtered (IP23), IP43 and NEMA 12 ventilated (IP54) enclosure.

# SINAMICS S120 Cabinet Modules

## Active Line Modules

### Options

The table below lists the available options for Active Line Modules (refer to **Description of the Options** for details).

Available Options	Option code	Available Options	Option code
CBC10 Communication Board (CANbus)	G20 <sup>1)</sup>	Special enclosure paint color [specify color]	Y09
CBE20 Communication Board (Ethernet)	G33 <sup>1)</sup>	Assembly into transport sections [specify sections]	Y11
Monitoring of precharge function	G56	1-line label for customer text, 40 x 80 mm [specify text]	Y31
AOP30 Advanced Operator Panel installed in the cabinet door	K08 <sup>1)</sup>	2-line label for customer text, 40 x 180 mm [specify text]	Y32
CU320-2 DP Control Unit (PROFIBUS DP)	K90	4-line label for customer text, 40 x 180 mm [specify text]	Y33
Performance expansion for CU320-2	K94 <sup>1)</sup>	Customer drawings in dxf format	D02
CU320-2 PN Control Unit (PROFINET)	K95	Advance copy of customer documentation (pdf)	D14
Enclosure space heater	L55	Documentation English/French	D58
25/125 kW braking unit (for frame size FX) for line voltages of 380 ... 480 V and 660 ... 690 V	L61	Nameplate English/French	T58
50/250 kW braking unit (for frame size GX/HX/JX) for line voltages of 380 ... 480 V and 660 ... 690 V	L62	Visual Inspection by customer	F03
25/125 kW braking unit (for frame size FX) for line voltages of 500 ... 600 V	L64	Witnessed or observed function test without motor	F71
50/250 kW braking unit (for frame size GX/HX/JX) for line voltages of 500 ... 600 V	L65	Witnessed or observed test incl. high-voltage and insulation test	F77
Base (plinth) 100mm	M06	Customer specific test (on request)	F97
Base (plinth) 200mm (cable marshalling space)	M07		
Enclosure NEMA 1 (IP21)	M21		
Enclosure NEMA 1 filtered (IP23) [includes M60]	M23		
Side panel (right)	M26		
Side panel (left)	M27		
Enclosure IP43 [includes M60]	M43		
Enclosure NEMA 12 (ventilated) (IP54) [includes M60]	M54		
Solid cabinet door (no ventilation openings, air inlet through floor)	M59		
Additional touch protection [included in <b>M23, M43 &amp; M54</b> ]	M60		
DC busbar system ( $I_d = 1,170$ A, 1x 60 x 10 mm)	M80		
DC busbar system ( $I_d = 1,500$ A, 1x 80 x 10 mm)	M81		
DC busbar system ( $I_d = 1,840$ A, 1x 100 x 10 mm)	M82		
DC busbar system ( $I_d = 2,150$ A, 2x 60 x 10 mm)	M83		
DC busbar system ( $I_d = 2,730$ A, 2x 80 x 10 mm)	M84		
DC busbar system ( $I_d = 3,320$ A, 2x 100 x 10 mm)	M85		
DC busbar system ( $I_d = 3,720$ A, 3x 80 x 10 mm)	M86		
DC busbar system ( $I_d = 4,480$ A, 3x 100 x 10 mm)	M87		
Lifting beam/eye bolts	M90		
UL listing per UL508A [requires <b>M23, M43 or M54</b> ]	U90		
cUL listing per UL508A for Canada [requires <b>M23, M43 or M54, plus T58</b> ]	U91		

<sup>1)</sup> Only in combination with options **K90** or **K95**.

### Options

#### Option combination matrix for Active Line Modules

The following tables provide an overview of possible and impermissible combinations of standard options. Please refer to the descriptions of options for more information. Custom configurations may be possible to provide combinations not available as standard – please contact the factory.

- ✓ Combination is possible
- Combination is not possible

#### Electrical Options

	G20	G33	K08	K90	K94	K95	K61	L62	L64	L65
G20		–	✓	✓	✓	✓	✓	✓	✓	✓
G33	–		✓	✓	✓	✓	✓	✓	✓	✓
K08	✓	✓		✓	✓	✓	✓	✓	✓	✓
K90	✓	✓	✓		✓	–	✓	✓	✓	✓
K94	✓	✓	✓	✓		✓	✓	✓	✓	✓
K95	✓	✓	✓	–	✓		✓	✓	✓	✓
L61	✓	✓	✓	✓	✓	✓		–	–	–
L62	✓	✓	✓	✓	✓	✓	–		–	–
L64	✓	✓	✓	✓	✓	✓	–	–		–
L65	✓	✓	✓	✓	✓	✓	–	–	–	

#### Mechanical Options

	M06	M07	M21	M23	M43	M54	M59	M60	M90	Y11	U90	U91
M06		–	✓	✓	✓	✓	✓	✓	✓	✓	✓	✓
M07	–		✓	✓	✓	✓	✓	✓	✓	✓	✓	✓
M21	✓	✓		–	–	–	✓	✓	✓	✓	–	–
M23	✓	✓	–		–	–	✓	–	✓	✓	✓	✓
M43	✓	✓	–	–		–	✓	–	✓	✓	✓	✓
M54	✓	✓	–	–	–		✓	–	✓	✓	✓	✓
M59	✓	✓	✓	✓	✓	✓		✓	✓	✓	✓	✓
M60	✓	✓	✓	–	–	–	✓		✓	✓	–	–
M90	✓	✓	✓	✓	✓	✓	✓	✓		–	✓	✓
Y11	✓	✓	✓	✓	✓	✓	✓	✓	–		✓	✓
U90	✓	✓	–	✓	✓	✓	✓	–	✓	✓		–
U91	✓	✓	–	✓	✓	✓	✓	–	✓	✓	–	

# SINAMICS S120 Cabinet Modules

## Active Line Modules

### Options

#### DC busbar system Options

Within a line-up, all DC bus needs to be of the same width (60, 80 or 100 mm). DC bus current ratings may vary within a line-up by using either a single busbar, or two or three busbars in parallel per pole.

The following table indicates which busbar options for the various cabinet modules may be combined within a line-up.



Combination is possible



Combination is not possible

	M80	M81	M82	M83	M84	M85	M86	M87
M80		-	-	✓	-	-	-	-
M81	-		-	-	✓	-	✓	-
M82	-	-		-	-	✓	-	✓
M83	✓	-	-		-	-	-	-
M84	-	✓	-	-		-	✓	-
M85	-	-	✓	-	-		-	✓
M86	-	✓	-	-	✓	-		-
M87	-	-	✓	-	-	✓	-	

#### Label Options

	Y31	Y32	Y33
Y31		-	-
Y32	-		-
Y33	-	-	





<b>4/3</b>	<b>Overview of Motor Modules</b> Motor Modules Chassis format Motor Modules Booksize format Control of Motor Modules Dynamic braking
<b>4/4</b>	<b>Motor Modules Chassis format</b> Overview Design Selection and ordering data Block diagram Technical data Options
<b>4/19</b>	<b>Motor Modules Booksize format</b> Overview Design Selection and ordering data Block diagram Technical data Options
<b>4/28</b>	<b>Braking Modules</b> Braking Modules – Chassis mounted Motor Modules Chassis format configured as braking units

## Motor Modules

### Overview of motor modules

Motor Modules are the link between the 3-phase AC motors and the common DC bus. They are IGBT based pulse width modulated (PWM) inverters that convert DC to variable voltage, variable frequency 3-phase AC to operate motors at variable speed. Motor Modules are inherently capable of four quadrant (4Q) operation, meaning that they can operate the motor in forward and reverse directions of operation, both when motoring (supplying power from the DC bus to the motor) or regenerating (taking power from the motor and feeding it to the DC bus). Motor Modules are available in two designs:

- **Chassis format:** Chassis format Motor Modules cover the power range from 125 to 900 kW (150 to 1,150 HP) at 380 – 480 V, and 70 to 1,000 kW (100 to 1,250 HP) at 500 – 600 V. The power rating can be increased up to almost 4,000 kW (5,000 HP) by connecting up to four motor modules in parallel. Each chassis format Motor Module is mounted in its own cabinet.
- **Booksize format:** At the low end of the power range from 4.8 kW to 82 kW (5 to 100 HP) at 380 V to 480 V only, Motor Modules are available as Booksize Cabinet Kits that are installed in Booksize Base Cabinets. Each Booksize Base Cabinet can contain multiple Booksize Cabinet Kits.

Motor Module cabinets may include optional power components (such as output reactors or filters) and control components (such as control units and/or encoder interface modules) as detailed in the respective sections. Alternatively, control components may be installed remotely and connected to the Motor Module by DRIVE-CLiQ cables. For example, control units, I/O modules and encoder interface modules may be mounted in a central control cabinet that does not contain any power circuits, or alternatively encoder interface and temperature sensor modules may be mounted near the motor, as appropriate.

Each motor module may have a dedicated control unit, or alternatively a Line Module and multiple Motor Modules may be controlled by a single control unit – the quantity of power modules controlled by a control unit depends on the type of control (vector or servo) and the required performance.

There are various possibilities to achieve dynamic braking:

- **Braking Modules mounted in chassis:** Braking Modules with continuous/peak braking powers of 25/125 kW (frame size FX) or 50/250 kW (frame size GX, HX, JX) can be mounted inside each chassis power block. Chassis with multiple power blocks can have a braking module mounted in each power block (2 for frame size HX, 3 for frame size JX). These braking modules are offered with matching braking resistors (each braking module requires its own resistor).
- **Motor Modules configured as Braking Modules:** All chassis format Motor Modules can be configured as braking modules, where a 3-phase resistor (or 3 resistors in wye connection) is connected to the output instead of a motor. Depending on the choice of motor module, continuous/peak braking powers in the range of approx. 100/150 kW to 1,500/2,200 kW can be obtained. SINAMICS S120 drive firmware includes the functionality to operate a motor module as a braking module as standard.

Central Braking Modules as offered in the IEC product spectrum of SINAMICS S120 Cabinet Modules are not included in this North American catalog since they are not UL listed. However, for line-ups that do not require UL listing they are available as another alternative to achieve high braking powers with a fast response time.

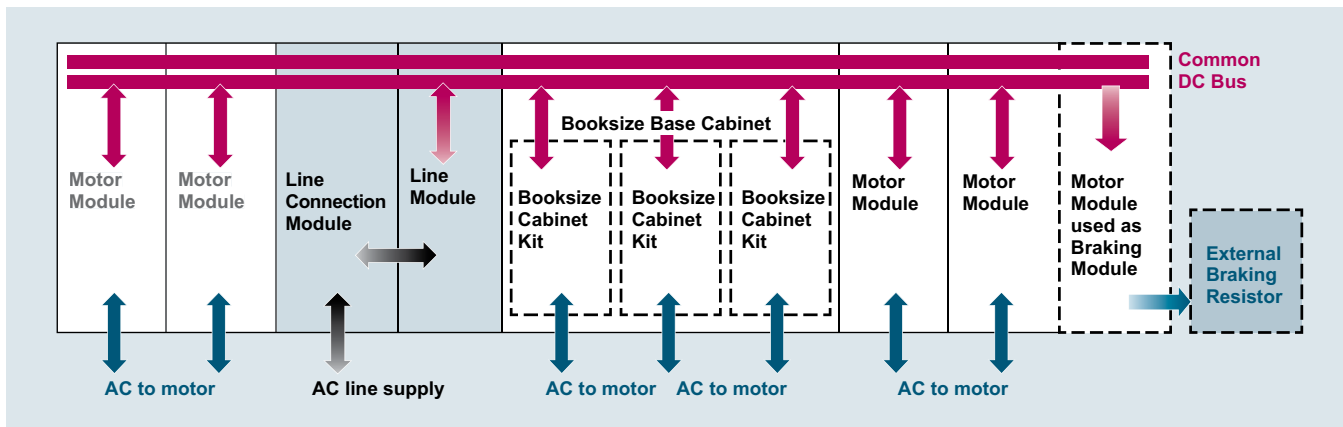

### Overview



Each Motor Module chassis format is mounted in its own cabinet. Motor Modules are available for the following voltages and currents.

Line voltage	Rated power
380 ... 480 V 3 ph. AC	125 ... 900 kW [150 ... 1,150 HP]
500 ... 600 (690) V 3 ph.	70 (75) ... 1,000 (1,200) kW [75 ... 1,250 HP @ 575V]

Up to four identical Motor Modules may be connected in parallel to increase the available shaft power up to approx. 4,750 HP (3,800 kW) at 575 V. Motor Modules connected in parallel are controlled by a single common control unit. Due to the possibility of unequal current sharing the rated current of the Motor Modules must be derated by 5%. Unless each Motor Module is connected to a single motor winding, some impedance must be provided on the output either by using motor reactors, or by running separate cables of a minimum length from each Motor Module.

For additional information, please refer to the [SINAMICS Low Voltage Engineering Manual](#).

### Design

Motor Modules in the chassis format contain the following components:

- Nickel plated DC bus, including DC connections to the Motor Module
- Nickel plated bus stabs for connecting motor cables for Motor Modules frame sizes FX and GX; for Motor Modules frame sizes HX and JX, the connection is made directly on the unit
- Cable support bar for the electric power cables
- DRIVE-CLiQ interface (3 DRIVE-CLiQ sockets), without Control Unit
- Customer terminal interface -X55
- Auxiliary power supply system (6-pole) for the auxiliary power supplies, including cable connections for looping through to the next Cabinet Module
- Ground (PE) busbar (60 × 10 mm), including jumper for looping through to the next Cabinet Module
- EMC-compliant design by additional shielding measures and appropriate routing of wiring.

# SINAMICS S120 Cabinet Modules

## Motor Modules Chassis Format

### Selection and ordering data

Rated power at 460 (400) V kW	Rated power at 460 V HP	Rated output current $I_N$ A	SCCR <sup>1)</sup> kA	Motor Module chassis format Order No.
Line voltage 380 ... 480 V 3ph. AC (DC bus voltage 510 ... 720 V DC)				
125 (110)	150	210	65	6SL3720-1TE32-1AU3
160 (132)	200	260	65	6SL3720-1TE32-6AU3
200 (160)	250	310	65	6SL3720-1TE33-1AU3
250 (200)	300	380	65	6SL3720-1TE33-8AU3
300 (250)	400	490	65	6SL3720-1TE35-0AU3
355 (315)	500	605	65	6SL3720-1TE36-1AU3
450 (400)	600	745	84	6SL3720-1TE37-5AU3
500 (450)	700	840	84	6SL3720-1TE38-4AU3
650 (560)	800	985	84	6SL3720-1TE41-0AU3
800 (710)	1,000	1,260	100	6SL3720-1TE41-2AU3
900 (800)	1,150	1,405	100	6SL3720-1TE41-4AU3

Rated power at 575 (690) kW	Rated power at 575 V HP	Rated output current $I_N$ A	SCCR <sup>1)</sup> kA	Motor Module chassis format Order No.
Line voltage 500 ... 690 V 3ph. AC (DC bus voltage 675 ... 900 V DC)				
60 (75)	75	85	65	6SL3720-1TG28-5AU3
75 (90)	100	100	65	6SL3720-1TG31-0AU3
90 (110)	125	120	65	6SL3720-1TG31-2AU3
110 (132)	150	150	65	6SL3720-1TG31-5AU3
132 (160)	150	175	65	6SL3720-1TG31-8AU3
160 (200)	200	216	65	6SL3720-1TG32-2AU3
200 (250)	250	260	65	6SL3720-1TG32-6AU3
250 (315)	300	330	65	6SL3720-1TG33-3AU3
300 (400)	400	410	65	6SL3720-1TG34-1AU3
350 (450)	450	465	65	6SL3720-1TG34-7AU3
450 (560)	600	575	84	6SL3720-1TG35-8AU3
560 (710)	700	735	84	6SL3720-1TG37-4AU3
630 (800)	800	810	84	6SL3720-1TG38-1AU3
750 (900)	900	910	100	6SL3720-1TG38-8AU3
800 (1,000)	1,000	1,025	100	6SL3720-1TG41-0AU3
1,000 (1,200)	1,250	1,270	100	6SL3720-1TG41-3AU3

<sup>1)</sup> Pending completion of the UL listing project of SINAMICS S120 Cabinet Modules, the SCCR of the line-up is limited by the SCCR of the smallest Motor Module it contains.

### Block diagram

Motor Modules are controlled by the CU320-2 DP or CU320-2 PN Control Unit. By selecting option codes K90 or K95 the Control Unit is included in the motor module cabinet, complete with the DRIVE-CLiQ cable connecting it to the motor module. However, if the Control Unit is also used to

control other motor modules, or if the Control Unit is to be mounted separately, the DRIVE-CLiQ cables are excluded and need to be added by others.

For additional information, please refer to the section on Integration Engineering, page 5/8.

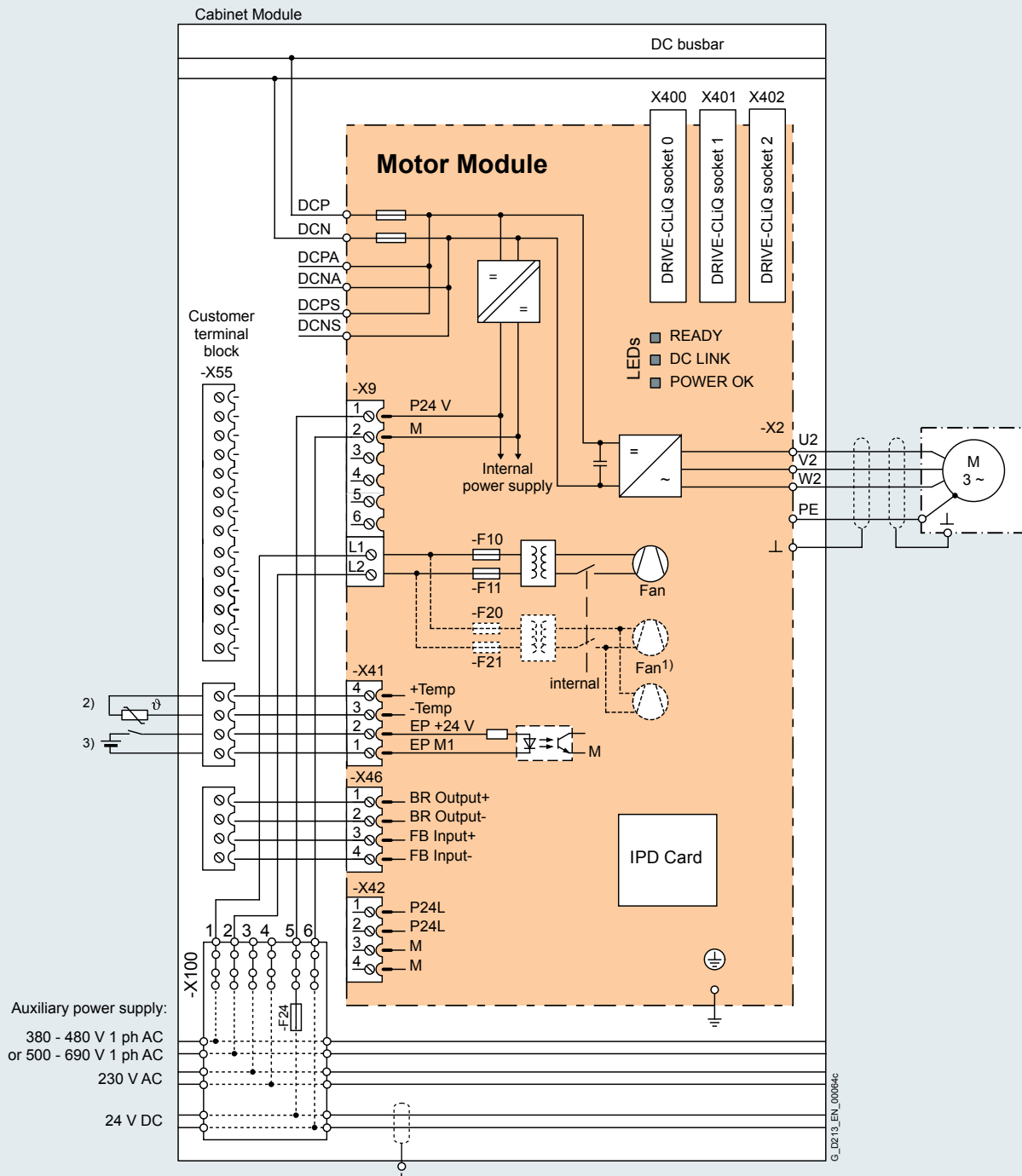

- 1) The number and the terminals of the fans depend on the frame size.
- 2) Connection of temperature sensor for motors without DRIVE-CLiQ interface.
- 3) Required for Safety Integrated.

Connection example of a Motor Module

# SINAMICS S120 Cabinet Modules

## Motor Modules Chassis Format

### Technical data

Line voltage 380 ... 480 V 3 ph. AC DC bus voltage 510 ... 720 V DC		Motor Module chassis format					
		6SL3720-1TE32-1AU3	6SL3720-1TE32-6AU3	6SL3720-1TE33-1AU3	6SL3720-1TE33-8AU3	6SL3720-1TE35-0AU3	6SL3720-1TE36-1AU3
<b>Rated power</b>							
• For $I_L$ (60 Hz, 460 V) <sup>1) 2)</sup>	kW [HP]	125 [150]	160 [200]	200 [250]	250 [300]	300 [400]	355 [500]
• For $I_L$ (50 Hz, 400 V) <sup>1)</sup>	kW	110	132	160	200	250	315
• For $I_H$ (60 Hz, 460 V) <sup>1) 2)</sup>	kW [HP]	110 [125]	132 [150]	160 [200]	200 [250]	250 [350]	315 [400]
• For $I_H$ (50 Hz, 400 V) <sup>1)</sup>	kW	90	110	132	160	200	250
<b>Output current</b>							
• Rated current $I_N$	A	210	260	310	380	490	605
• Base load current $I_L$ <sup>3)</sup>	A	205	250	302	370	477	590
• Base load current $I_H$ <sup>4)</sup>	A	178	233	277	340	438	460
• Maximum current $I_{max A}$	A	307	375	453	555	715	885
<b>DC bus current</b>							
• Rated current $I_{N DC}$ if supplied by							
- Basic/Smart Line Module	A	252	312	372	456	588	726
- Active Line Module	A	227	281	335	411	529	653
• Rated current $I_{L DC}$ <sup>3)</sup> if supplied by							
- Basic/Smart Line Module	A	245	304	362	444	573	707
- Active Line Module	A	221	273	326	400	515	636
• Rated current $I_{H DC}$ <sup>4)</sup> if supplied by							
- Basic/Smart Line Module	A	224	277	331	405	523	646
- Active Line Module	A	202	250	298	365	470	581
<b>Current demand</b>							
• 24V DC auxiliary power supply	A	0.8	0.8	0.9	0.9	0.9	1.0
• 460 (400) V AC	A	0.63	1.13	1.8	1.8	1.8	3.6
<b>DC bus capacitance</b>		μF	4,200	5,200	6,300	7,800	9,600
<b>Pulse frequency</b> <sup>5)</sup>							
• Rated	kHz	2	2	2	2	2	1.25
• Maximum (with derating)	kHz	8	8	8	8	8	7.5
<b>Power loss, max.</b> <sup>6)</sup>							
• At 60 Hz 460V [50 Hz 400V]	kW	1.94 [1.86]	2.6 [2.5]	3.1 [2.96]	3.8 [3.67]	4.5 [4.28]	6.3 [5.84]
<b>Cooling air requirement</b>		cfm [m <sup>3</sup> /s]	360 [0.17]	487 [0.23]	763 [0.36]	763 [0.36]	1,653 [0.78]
<b>Sound pressure level <math>L_{pA}</math> (1m) at 60 [50] Hz</b>		dB(A)	67	69	69	69	72

1) Rated power in kW is of a typical 6-pole standard induction motor with an FLA of  $I_L$  or  $I_H$  at the listed voltage and frequency.

2) Rated power in HP is based on NEC table 430-150. Note that **HP ratings are provided as a guide only**, for standard 2, 4 or 6 pole motors. Actual motor currents may be higher, especially for motors with 8 or more poles.

3) The base load current  $I_L$  is the basis for a duty cycle of duration of 300 s with an overload of 110 % for 60 s or 150 % for 10 s.

4) The base load current  $I_H$  is the basis for a duty cycle of duration of 300 s with an overload of 150 % for 60 s or 160 % for 10 s.

5) Information regarding the correlation between the pulse frequency and max. output current/output frequency is provided in the SINAMICS Low Voltage Engineering Manual.

6) The specified power loss represents the maximum value at 100 % utilization. The value is lower under normal operating conditions.

### Technical data

Line voltage 380 ... 480 V 3 ph. AC DC bus voltage 510 ... 720 V DC		Motor Module chassis format					
		6SL3720-1TE32-1AU3	6SL3720-1TE32-6AU3	6SL3720-1TE33-1AU3	6SL3720-1TE33-8AU3	6SL3720-1TE35-0AU3	6SL3720-1TE36-1AU3
<b>Motor connection U2, V2, W2</b>							
• Conductor size, max.		2x 350 MCM	2x 350 MCM	2x 500 MCM	2x 500 MCM	2x 500 MCM	4x 500 MCM
<b>Output cable length, max. <sup>7)</sup></b>							
• Shielded		ft (m)	980 [300]	980 [300]	980 [300]	980 [300]	980 [300]
• Unshielded		ft (m)	1,480 [450]	1,480 [450]	1,480 [450]	1,480 [450]	1,480 [450]
<b>Enclosure (base design)</b>			IP20	IP20	IP20	IP20	IP20
<b>Enclosure dimensions, nominal</b>							
• Width <sup>8)</sup>		inch [mm]	16 [400]	16 [400]	16 [400]	16 [400]	24 [600]
• Height <sup>9)</sup>		inch [mm]	87 [2,200]	87 [2,200]	87 [2,200]	87 [2,200]	87 [2,200]
• Depth		inch [mm]	24 [600]	24 [600]	24 [600]	24 [600]	24 [600]
<b>Weight, approx.</b>		lb [kg]	320 [145]	320 [145]	631 [286]	631 [286]	1,080 [490]
<b>Frame size</b>			FX	FX	GX	GX	HX
<b>Short Circuit Current Rating (SCCR) per UL508A</b>		kA	65	65	65	65	65

- 7) Sum of lengths of all motor cables. Longer cable lengths for specific configurations may be available on request. [For additional information, please refer to the SINAMICS Low Voltage Engineering Manual.](#)
- 8) Option **L10** (dv/dt filter plus VPL) for frame sizes FX/GX/HX/JX requires a supplementary cabinet 24" (600 mm) wide.  
Option **L08** (motor reactor) for frame sizes HX/JX requires a supplementary cabinet 24" (600 mm) wide.
- 9) The enclosure height increases by 10" (250 mm) for NEMA 1 (IP21) and by 16" (400 mm) for NEMA 1 filtered (IP23), IP43 and NEMA 12 ventilated (IP54) enclosure.

# SINAMICS S120 Cabinet Modules

## Motor Modules Chassis Format

### Technical data

Line voltage 380 ... 480 V 3 ph. AC DC bus voltage 510 ... 720 V DC		Motor Module chassis format				
		6SL3720-1TE37-5AU3	6SL3720-1TE38-4AU3	6SL3720-1TE41-0AU3	6SL3720-1TE41-2AU3	6SL3720-1TE41-4AU3
<b>Rated power</b>						
• For $I_L$ (60 Hz, 460 V) <sup>1) 2)</sup>	kW [HP]	450 [600]	500 [700]	630 [800]	800 [1,000]	900 [1,150]
• For $I_L$ (50 Hz, 400 V) <sup>1)</sup>	kW	400	450	560	710	800
• For $I_H$ (60 Hz, 460 V) <sup>1) 2)</sup>	kW [HP]	355 [500]	450 [600]	500 [700]	630 [900]	800 [1,000]
• For $I_H$ (50 Hz, 400 V) <sup>1)</sup>	kW	315	400	450	560	710
<b>Output current</b>						
• Rated current $I_{NA}$	A	745	840	985	1,260	1,405
• Base load current $I_L$ <sup>3)</sup>	A	725	820	960	1,230	1,370
• Base load current $I_H$ <sup>4)</sup>	A	570	700	860	1,127	1,257
• Maximum current $I_{maxA}$	A	1,087	1,230	1,440	1,845	2,055
<b>DC bus current</b>						
• Rated current $I_{NDC}$ if supplied by						
- Basic/Smart Line Module	A	894	1,008	1,182	1,512	1,686
- Active Line Module	A	805	907	1,064	1,361	1,517
• Rated current $I_{LDC}$ <sup>3)</sup> if supplied by						
- Basic/Smart Line Module	A	871	982	1,152	1,474	1,643
- Active Line Module	A	784	884	1,037	1,326	1,479
• Rated current $I_{HDC}$ <sup>4)</sup> if supplied by						
- Basic/Smart Line Module	A	795	897	1,051	1,345	1,500
- Active Line Module	A	716	807	946	1,211	1,350
<b>Current demand</b>						
• 24V DC auxiliary power supply	A	1.0	1.0	1.25	1.4	1.4
• 460 (400) V AC	A	3.6	3.6	5.4	5.4	5.4
<b>DC bus capacitance</b>	μF	15,600	16,800	18,900	26,100	28,800
<b>Pulse frequency</b> <sup>5)</sup>						
• Rated	kHz	1.25	1.25	1.25	1.25	1.25
• Maximum (with derating)	kHz	7.5	7.5	7.5	7.5	7.5
<b>Power loss, max.</b> <sup>6)</sup>						
• At 60 Hz 460V [50 Hz 400V]	kW	7.3 [6.68]	7.8 [7.15]	10.2 [9.5]	12.0 [11.1]	13.0 [12.0]
<b>Cooling air requirement</b>	cfm [m <sup>3</sup> /s]	1,653 [0.78]	1,653 [0.78]	2,331 [1.1]	2,331 [1.1]	2,331 [1.1]
<b>Sound pressure level</b> $L_{pA}$ (1m) at 60 [50] Hz	dB(A)	72	72	72	72	72

1) Rated power in kW is of a typical 6-pole standard induction motor with an FLA of  $I_L$  or  $I_H$  at the listed voltage and frequency.

2) Rated power in HP is based on NEC table 430-150. Note that **HP ratings are provided as a guide only**, for standard 2, 4 or 6 pole motors. Actual motor currents may be higher, especially for motors with 8 or more poles.

3) The base load current  $I_L$  is the basis for a duty cycle of duration of 300 s with an overload of 110 % for 60 s or 150 % for 10 s.

4) The base load current  $I_H$  is the basis for a duty cycle of duration of 300 s with an overload of 150 % for 60 s or 160 % for 10 s.

5) Information regarding the correlation between the pulse frequency and max. output current/output frequency is provided in the SINAMICS Low Voltage Engineering Manual.

6) The specified power loss represents the maximum value at 100 % utilization. The value is lower under normal operating conditions.



# SINAMICS S120 Cabinet Modules

## Motor Modules Chassis Format

### Technical data

Line voltage 380 ... 480 V 3 ph. AC DC bus voltage 510 ... 720 V DC		Motor Module chassis format				
		6SL3720-1TE37-5AU3	6SL3720-1TE38-4AU3	6SL3720-1TE41-0AU3	6SL3720-1TE41-2AU3	6SL3720-1TE41-4AU3
<b>Motor connection U2, V2, W2</b>						
• Conductor size, max.		4x 500 MCM	4x 500 MCM	6x 500 MCM	6x 500 MCM	6x 500 MCM
<b>Output cable length, max. <sup>7)</sup></b>						
• Shielded		ft (m)	980 [300]	980 [300]	980 [300]	980 [300]
• Unshielded		ft (m)	1,480 [450]	1,480 [450]	1,480 [450]	1,480 [450]
<b>Enclosure (base design)</b>			IP20	IP20	IP20	IP20
<b>Enclosure dimensions, nominal</b>						
• Width <sup>8)</sup>		inch [mm]	24 [600]	24 [600]	31.5 [800]	31.5 [800]
• Height <sup>9)</sup>		inch [mm]	87 [2,200]	87 [2,200]	87 [2,200]	87 [2,200]
• Depth		inch [mm]	24 [600]	24 [600]	24 [600]	24 [600]
<b>Weight, approx.</b>		lb [kg]	1,080 [490]	1,080 [490]	1,543 [700]	1,543 [700]
<b>Frame size</b>			HX	HX	JX	JX
<b>Short Circuit Current Rating (SCCR) per UL508A</b>		kA	84	84	84	100

4

<sup>7)</sup> Sum of lengths of all motor cables. Longer cable lengths for specific configurations may be available on request. **For additional information, please refer to the SINAMICS Low Voltage Engineering Manual.**

<sup>8)</sup> Option **L10** (dv/dt filter plus VPL) for frame sizes FX/GX/HX/JX requires a supplementary cabinet 24" (600 mm) wide.  
Option **L08** (motor reactor) for frame sizes HX/JX requires a supplementary cabinet 24" (600 mm) wide.

<sup>9)</sup> The enclosure height increases by 10" (250 mm) for NEMA 1 (IP21) and by 16" (400 mm) for NEMA 1 filtered (IP23), IP43 and NEMA 12 ventilated (IP54) enclosure.

# SINAMICS S120 Cabinet Modules

## Motor Modules Chassis Format

### Technical data

Line voltage 500 ... 600 (690) V 3ph. AC (DC bus voltage 675 ... 900 (1,035) V DC) Note: UL Listing is valid only for $\leq 600$ V		Motor Module chassis format					
		6SL3720-1TG28-5AU3	6SL3720-1TG31-0AU3	6SL3720-1TG31-2AU3	6SL3720-1TG31-5AU3	6SL3720-1TG31-8AU3	6SL3720-1TG32-2AU3
<b>Rated power</b>							
• For $I_L$ (60 Hz, 575 V) <sup>1) 2)</sup>	kW [HP]	55 [75]	75 [100]	90 [125]	110 [150]	132 [150]	160 [200]
• For $I_L$ (50 Hz, 690 V) <sup>1)</sup>	kW	75	90	110	132	160	200
• For $I_H$ (60 Hz, 575 V) <sup>1) 2)</sup>	kW [HP]	45 [60]	55 [75]	75 [100]	90 [125]	110 [150]	132 [200]
• For $I_H$ (50 Hz, 690 V) <sup>1)</sup>	kW	55	75	90	110	132	160
<b>Output current</b>							
• Rated current $I_{N A}$	A	85	100	120	150	175	215
• Base load current $I_L$ <sup>3)</sup>	A	80	95	115	142	170	208
• Base load current $I_H$ <sup>4)</sup>	A	76	89	107	134	157	192
• Maximum current $I_{max A}$	A	120	142	172	213	255	312
<b>DC bus current</b>							
• Rated current $I_{N DC}$ if supplied by							
- Basic/Smart Line Module	A	102	120	144	180	210	258
- Active Line Module	A	92	108	130	162	189	232
• Rated current $I_{L DC}$ <sup>3)</sup> if supplied by							
- Basic/Smart Line Module	A	99	117	140	175	204	251
- Active Line Module	A	89	105	126	157	184	226
• Rated current $I_{H DC}$ <sup>4)</sup> if supplied by							
- Basic/Smart Line Module	A	90	106	128	160	186	229
- Active Line Module	A	81	96	115	144	168	206
<b>Current demand</b>							
• 24V DC auxiliary power supply	A	0.8	0.8	0.8	0.8	0.9	0.9
• 575 (690) V AC	A	0.4	0.4	0.4	0.4	1.0	1.0
<b>DC bus capacitance</b>		$\mu$ F	1,200	1,200	1,600	2,800	2,800
<b>Pulse frequency</b> <sup>5)</sup>							
• Rated	kHz	1.25	1.25	1.25	1.25	1.25	1.25
• Maximum (with derating)	kHz	7.5	7.5	7.5	7.5	7.5	7.5
<b>Power loss, max.</b> <sup>6)</sup>							
• At 60 Hz 475V [50 Hz 690V]	kW	1.1 [1.17]	1.3 [1.43]	1.77 [1.89]	1.62 [1.8]	2.5 [2.67]	2.91 [3.09]
<b>Cooling air requirement</b>		cfm [m <sup>3</sup> /s]	360 [0.17]	360 [0.17]	360 [0.17]	360 [0.17]	763 [0.36]
<b>Sound pressure level</b> $L_{pA}$ (1m) at 60 [50] Hz		dB(A)	67	67	67	67	69

1) Rated power in kW is of a typical 6-pole standard induction motor with an FLA of  $I_L$  or  $I_H$  at the listed voltage and frequency.

2) Rated power in HP is based on NEC table 430-150. Note that **HP ratings are provided as a guide only**, for standard 2, 4 or 6 pole motors. Actual motor currents may be higher, especially for motors with 8 or more poles.

3) The base load current  $I_L$  is the basis for a duty cycle of duration of 300 s with an overload of 110 % for 60 s or 150 % for 10 s.

4) The base load current  $I_H$  is the basis for a duty cycle of duration of 300 s with an overload of 150 % for 60 s or 160 % for 10 s.

5) Information regarding the correlation between the pulse frequency and max. output current/output frequency is provided in the SINAMICS Low Voltage Engineering Manual.

6) The specified power loss represents the maximum value at 100 % utilization. The value is lower under normal operating conditions.

### Technical data

Line voltage 500 ... 600 (690) V 3ph. AC (DC bus voltage 675 ... 900 (1,035) V DC) Note: UL Listing is valid only for ≤ 600 V		Motor Module chassis format					
		6SL3720-1TG28-5AU3	6SL3720-1TG31-0AU3	6SL3720-1TG31-2AU3	6SL3720-1TG31-5AU3	6SL3720-1TG31-8AU3	6SL3720-1TG32-2AU3
<b>Motor connection U2, V2, W2</b>							
• Conductor size, max.		2x 350 MCM	2x 350 MCM	2x 350 MCM	2x 350 MCM	2x 500 MCM	2x 500 MCM
<b>Output cable length, max. <sup>7)</sup></b>							
• Shielded		ft (m)	980 [300]	980 [300]	980 [300]	980 [300]	980 [300]
• Unshielded		ft (m)	1,480 [450]	1,480 [450]	1,480 [450]	1,480 [450]	1,480 [450]
<b>Enclosure (base design)</b>			IP20	IP20	IP20	IP20	IP20
<b>Enclosure dimensions, nominal</b>							
• Width <sup>8)</sup>		inch [mm]	16 [400]	16 [400]	16 [400]	16 [400]	16 [400]
• Height <sup>9)</sup>		inch [mm]	87 [2,200]	87 [2,200]	87 [2,200]	87 [2,200]	87 [2,200]
• Depth		inch [mm]	24 [600]	24 [600]	24 [600]	24 [600]	24 [600]
<b>Weight, approx.</b>		lb [kg]	320 [145]	320 [145]	320 [145]	631 [286]	631 [286]
<b>Frame size</b>			FX	FX	FX	GX	GX
<b>Short Circuit Current Rating (SCCR) per UL508A</b>		kA	65	65	65	65	65

- 7) Sum of lengths of all motor cables. Longer cable lengths for specific configurations may be available on request. [For additional information, please refer to the SINAMICS Low Voltage Engineering Manual.](#)
- 8) Option **L10** (dv/dt filter plus VPL) for frame sizes FX/GX/HX/JX requires a supplementary cabinet 24" (600 mm) wide.  
Option **L08** (motor reactor) for frame sizes HX/JX requires a supplementary cabinet 24" (600 mm) wide.
- 9) The enclosure height increases by 10" (250 mm) for NEMA 1 (IP21) and by 16" (400 mm) for NEMA 1 filtered (IP23), IP43 and NEMA 12 ventilated (IP54) enclosure.

# SINAMICS S120 Cabinet Modules

## Motor Modules Chassis Format

### Technology

Line voltage 500 ... 600 (690) V 3ph. AC (DC bus voltage 675 ... 900 (1,035) V DC) Note: UL Listing is valid only for $\leq 600$ V	Motor Module chassis format					
		6SL3720-1TG32-6AU3	6SL3720-1TG33-3AU3	6SL3720-1TG34-1AU3	6SL3720-1TG34-7AU3	6SL3720-1TG35-8AU3
<b>Rated power</b>						
• For $I_L$ (60 Hz, 575 V) <sup>1) 2)</sup>	kW [HP]	200 [250]	250 [300]	300 [400]	400 [450]	450 [600]
• For $I_L$ (50 Hz, 690 V) <sup>1)</sup>	kW	250	315	400	450	560
• For $I_H$ (60 Hz, 575 V) <sup>1) 2)</sup>	kW [HP]	160 [250]	200 [300]	250 [350]	315 [450]	400 [500]
• For $I_H$ (50 Hz, 690 V) <sup>1)</sup>	kW	200	250	315	400	450
<b>Output current</b>						
• Rated current $I_{NA}$	A	260	330	410	465	575
• Base load current $I_L$ <sup>3)</sup>	A	250	320	400	452	560
• Base load current $I_H$ <sup>4)</sup>	A	233	280	367	416	514
• Maximum current $I_{maxA}$	A	375	480	600	678	840
<b>DC bus current</b>						
• Rated current $I_{NDC}$ if supplied by						
- Basic/Smart Line Module	A	312	396	492	558	690
- Active Line Module	A	281	356	443	502	621
• Rated current $I_{LDC}$ <sup>3)</sup> if supplied by						
- Basic/Smart Line Module	A	304	386	479	544	672
- Active Line Module	A	273	347	431	489	605
• Rated current $I_{HDC}$ <sup>4)</sup> if supplied by						
- Basic/Smart Line Module	A	277	352	437	496	614
- Active Line Module	A	250	316	394	446	552
<b>Current demand</b>						
• 24V DC auxiliary power supply	A	0.9	0.9	1.0	1.0	1.0
• 575 (690) V AC	A	1.0	1.0	2.1	2.1	2.1
<b>DC bus capacitance</b>	$\mu$ F	3900	4200	7400	7400	7400
<b>Pulse frequency</b> <sup>5)</sup>						
• Rated	kHz	1.25	1.25	1.25	1.25	1.25
• Maximum (with derating)	kHz	7.5	7.5	7.5	7.5	7.5
<b>Power loss, max.</b> <sup>6)</sup>						
• At 60 Hz 475V [50 Hz 690V]	kW	3.38 [3.62]	3.98 [4.34]	5.71 [6.13]	6.32 [6.8]	9.7 [10.3]
<b>Cooling air requirement</b>	cfm [m <sup>3</sup> /s]	763 [0.36]	763 [0.36]	1,653 [0.78]	1,653 [0.78]	1,653 [0.78]
<b>Sound pressure level</b> $L_{pA}$ (1m) at 60 [50] Hz	dB(A)	69	69	72	72	72

1) Rated power in kW is of a typical 6-pole standard induction motor with an FLA of  $I_L$  or  $I_H$  at the listed voltage and frequency.

2) Rated power in HP is based on NEC table 430-150. Note that **HP ratings are provided as a guide only**, for standard 2, 4 or 6 pole motors. Actual motor currents may be higher, especially for motors with 8 or more poles.

3) The base load current  $I_L$  is the basis for a duty cycle of duration of 300 s with an overload of 110 % for 60 s or 150 % for 10 s.

4) The base load current  $I_H$  is the basis for a duty cycle of duration of 300 s with an overload of 150 % for 60 s or 160 % for 10 s.

5) Information regarding the correlation between the pulse frequency and max. output current/output frequency is provided in the SINAMICS Low Voltage Engineering Manual.

6) The specified power loss represents the maximum value at 100 % utilization. The value is lower under normal operating conditions.

### Technology

Line voltage 500 ... 600 (690) V 3ph. AC (DC bus voltage 675 ... 900 (1,035) V DC) Note: UL Listing is valid only for ≤ 600 V		Motor Module chassis format				
		6SL3720-1TG32-6AU3	6SL3720-1TG33-3AU3	6SL3720-1TG34-6AU3	6SL3720-1TG34-7AU3	6SL3720-1TG35-8AU3
<b>Motor connection U2, V2, W2</b>						
• Conductor size, max.		2x 500 MCM	2x 500 MCM	4x 500 MCM	4x 500 MCM	4x 500 MCM
<b>Output cable length, max. <sup>7)</sup></b>						
• Shielded		ft (mm)	980 [300]	980 [300]	980 [300]	980 [300]
• Unshielded		ft (mm)	1,480 [450]	1,480 [450]	1,480 [450]	1,480 [450]
<b>Enclosure (base design)</b>			IP20	IP20	IP20	IP20
<b>Enclosure dimensions, nominal</b>						
• Width <sup>8)</sup>		inch [mm]	16 [400]	16 [400]	24 [600]	24 [600]
• Height <sup>9)</sup>		inch [mm]	87 [2,200]	87 [2,200]	87 [2,200]	87 [2,200]
• Depth		inch [mm]	24 [600]	24 [600]	24 [600]	24 [600]
<b>Weight, approx.</b>		lb [kg]	631 [286]	631 [286]	1,080 [490]	1,080 [490]
<b>Frame size</b>			GX	GX	HX	HX
<b>Short Circuit Current Rating (SCCR) per UL508A</b>		kA	65	65	65	84

- <sup>7)</sup> Sum of lengths of all motor cables. Longer cable lengths for specific configurations may be available on request. **For additional information, please refer to the SINAMICS Low Voltage Engineering Manual.**
- <sup>8)</sup> Option **L10** (dv/dt filter plus VPL) for frame sizes FX/GX/HX/JX requires a supplementary cabinet 24" (600 mm) wide.  
Option **L08** (motor reactor) for frame sizes HX/JX requires a supplementary cabinet 24" (600 mm) wide.
- <sup>9)</sup> The enclosure height increases by 10" (250 mm) for NEMA 1 (IP21) and by 16" (400 mm) for NEMA 1 filtered (IP23), IP43 and NEMA 12 ventilated (IP54) enclosure.

# SINAMICS S120 Cabinet Modules

## Motor Modules Chassis Format

### Technology

Line voltage 500 ... 600 (690) V 3ph. AC (DC bus voltage 675 ... 900 (1,035) V DC) Note: UL Listing is valid only for $\leq 600$ V	Motor Module chassis format					
		6SL3720-1TG37-4AU3	6SL3720-1TG38-1AU3	6SL3720-1TG38-8AU3	6SL3720-1TG41-0AU3	6SL3720-1TG41-3AU3
<b>Rated power</b>						
• For $I_L$ (60 Hz, 575 V) <sup>1) 2)</sup>	kW [HP]	560 [700]	630 [800]	710 [900]	800 [1,000]	1,000 [1,250]
• For $I_L$ (50 Hz, 690 V) <sup>1)</sup>	kW	710	800	900	1,000	1,200
• For $I_H$ (60 Hz, 575 V) <sup>1) 2)</sup>	kW [HP]	500 [600]	560 [700]	630 [800]	710 [900]	800 [1,000]
• For $I_H$ (50 Hz, 690 V) <sup>1)</sup>	kW	630	710	800	900	1,000
<b>Output current</b>						
• Rated current $I_{NA}$	A	735	810	910	1,025	1,270
• Base load current $I_L$ <sup>3)</sup>	A	710	790	880	1,000	1,230
• Base load current $I_H$ <sup>4)</sup>	A	657	724	814	917	1,136
• Maximum current $I_{maxA}$	A	1,065	1,185	1,320	1,500	1,845
<b>DC bus current</b>						
• Rated current $I_{NDC}$ if supplied by						
- Basic/Smart Line Module	A	882	972	1,092	1,230	1,524
- Active Line Module	A	794	875	983	1,107	1,372
• Rated current $I_{LDC}$ <sup>3)</sup> if supplied by						
- Basic/Smart Line Module	A	859	947	1,064	1,199	1,485
- Active Line Module	A	774	853	958	1,079	1,337
• Rated current $I_{HDC}$ <sup>4)</sup> if supplied by						
- Basic/Smart Line Module	A	784	865	971	1,094	1,356
- Active Line Module	A	706	778	874	985	1,221
<b>Current demand</b>						
• 24V DC auxiliary power supply	A	1.25	1.25	1.4	1.4	1.4
• 575 (690) V AC	A	3.1	3.1	3.1	3.1	3.1
<b>DC bus capacitance</b>	$\mu$ F	11,100	11,100	14,400	14,400	19,200
<b>Pulse frequency</b> <sup>5)</sup>						
• Rated	kHz	1.25	1.25	1.25	1.25	1.25
• Maximum (with derating)	kHz	7.5	7.5	7.5	7.5	7.5
<b>Power loss, max.</b> <sup>6)</sup>						
• At 60 Hz 475V [50 Hz 690V]	kW	10 [10.9]	10.5 [11.5]	10.6 [11.7]	12 [13.2]	14.2 [16]
<b>Cooling air requirement</b>	cfm [m <sup>3</sup> /s]	3,123 [1.474]	3,123 [1.474]	3,123 [1.474]	3,123 [1.474]	3,123 [1.474]
<b>Sound pressure level <math>L_{pA}</math> (1m)</b> at 60 [50] Hz	dB(A)	72	72	72	72	72

1) Rated power in kW is of a typical 6-pole standard induction motor with an FLA of  $I_L$  or  $I_H$  at the listed voltage and frequency.

2) Rated power in HP is based on NEC table 430-150. Note that **HP ratings are provided as a guide only**, for standard 2, 4 or 6 pole motors. Actual motor currents may be higher, especially for motors with 8 or more poles.

3) The base load current  $I_L$  is the basis for a duty cycle of duration of 300 s with an overload of 110 % for 60 s or 150 % for 10 s.

4) The base load current  $I_H$  is the basis for a duty cycle of duration of 300 s with an overload of 150 % for 60 s or 160 % for 10 s.

5) Information regarding the correlation between the pulse frequency and max. output current/output frequency is provided in the SINAMICS Low Voltage Engineering Manual.

6) The specified power loss represents the maximum value at 100 % utilization. The value is lower under normal operating conditions.

### Technology

Line voltage 500 ... 600 (690) V 3ph. AC (DC bus voltage 675 ... 900 (1,035) V DC) Note: UL Listing is valid only for ≤ 600 V		Motor Module chassis format				
		6SL3720-1 TG37-4AU3	6SL3720-1 TG38-1AU3	6SL3720-1 TG38-8AU3	6SL3720-1 TG41-0AU3	6SL3720-1 TG41-3AU3
<b>Motor connection U2, V2, W2</b>						
• Conductor size, max.		6x 500 MCM	6x 500 MCM	6x 500 MCM	6x 500 MCM	6x 500 MCM
<b>Output cable length, max. <sup>7)</sup></b>						
• Shielded		ft (m)	980 [300]	980 [300]	980 [300]	980 [300]
• Unshielded		ft (m)	1,480 [450]	1,480 [450]	1,480 [450]	1,480 [450]
<b>Enclosure (base design)</b>			IP20	IP20	IP20	IP20
<b>Enclosure dimensions, nominal</b>						
• Width <sup>8)</sup>		inch [mm]	31.5 [800]	31.5 [800]	31.5 [800]	31.5 [800]
• Height <sup>9)</sup>		inch [mm]	87 [2,200]	87 [2,200]	87 [2,200]	87 [2,200]
• Depth		inch [mm]	24 [600]	24 [600]	24 [600]	24 [600]
<b>Weight, approx.</b>		lb [kg]	1,543 [700]	1,543 [700]	1,543 [700]	1,543 [700]
<b>Frame size</b>			JX	JX	JX	JX
<b>Short Circuit Current Rating (SCCR) per UL508A</b>		kA	84	84	100	100

7) Sum of lengths of all motor cables. Longer cable lengths for specific configurations may be available on request. [For additional information, please refer to the SINAMICS Low Voltage Engineering Manual.](#)

8) Option **L10** (dv/dt filter plus VPL) for frame sizes FX/GX/HX/JX requires a supplementary cabinet 24" (600 mm) wide.  
Option **L08** (motor reactor) for frame sizes HX/JX requires a supplementary cabinet 24" (600 mm) wide.

9) The enclosure height increases by 10" (250 mm) for NEMA 1 (IP21) and by 16" (400 mm) for NEMA 1 filtered (IP23), IP43 and NEMA 12 ventilated (IP54) enclosure.

# SINAMICS S120 Cabinet Modules

## Motor Modules Chassis Format

### Options

The table below lists the available options for Motor Modules chassis format (refer to **Description of the Options** for details).

Available Options	Option code
CBC10 Communication Board (CANbus)	G20 <sup>1)</sup>
CBE20 Communication Board (Ethernet)	G33 <sup>1)</sup>
Monitoring of precharge function	G56 <sup>3)</sup>
Safety license for 1 to 5 axes	K01 to K05
AOP30 Advanced Operator Panel installed in the cabinet door	K08 <sup>1)</sup>
SMC10 Sensor Module Cabinet-Mounted	K46
SMC20 Sensor Module Cabinet-Mounted	K48
SMC30 Sensor Module Cabinet-Mounted	K50
VSM10 Voltage Sensing Module	K51
Additional SMC30 Sensor Module	K52
Terminal interface for the Safe Torque Off and Safe Stop 1 safety functions	K82
TM54F Terminal Module	K87
Safe Brake Adapter SBA, 230 V AC	K88 <sup>2)</sup>
CU320-2 DP Control Unit (PROFIBUS DP)	K90
Performance expansion for CU320-2	K94 <sup>1)</sup>
CU320-2 PN Control Unit (PROFINET)	K95
dV/dt filter compact plus Voltage Peak Limiter	L07
Motor reactor	L08
dV/dt filter plus Voltage Peak Limiter	L10
Output circuit breaker (motorized)	L34
DC disconnect with precharge circuit for the associated DC bus capacitance (includes M60)	L37 <sup>2)</sup>
Enclosure space heater	L55
25/125 kW braking unit (for frame size FX) for line voltages of 380 ... 480 V and 660 ... 690 V	L61
50/250 kW braking unit (for frame size GX/HX/JX) for line voltages of 380 ... 480 V and 660 ... 690 V	L62
25/125 kW braking unit (for frame size FX) for line voltages of 500 ... 600 V	L64
50/250 kW braking unit (for frame size GX/HX/JX) for line voltages of 500 ... 600 V	L65

Available Options	Option code
Base (plinth) 100mm	M06
Base (plinth) 200mm (cable marshalling space)	M07
Enclosure NEMA 1 (IP21)	M21
Enclosure NEMA 1 filtered (IP23) [includes M60]	M23
Side panel (right)	M26
Side panel (left)	M27
Enclosure IP43 [includes M60]	M43
Enclosure NEMA 12 (ventilated) (IP54) [includes M60]	M54
Solid cabinet door (no ventilation openings, air inlet through floor)	M59
Additional touch protection [included in M23, M43 & M54]	M60
DC busbar system ( $I_d = 1,170$ A, 1x 60 x 10 mm)	M80
DC busbar system ( $I_d = 1,500$ A, 1x 80 x 10 mm)	M81
DC busbar system ( $I_d = 1,840$ A, 1x 100 x 10 mm)	M82
DC busbar system ( $I_d = 2,150$ A, 2x 60 x 10 mm)	M83
DC busbar system ( $I_d = 2,730$ A, 2x 80 x 10 mm)	M84
DC busbar system ( $I_d = 3,320$ A, 2x 100 x 10 mm)	M85
DC busbar system ( $I_d = 3,720$ A, 3x 80 x 10 mm)	M86
DC busbar system ( $I_d = 4,480$ A, 3x 100 x 10 mm)	M87
Lifting beam/eye bolts	M90
UL listing per UL508A [requires M23, M43 or M54]	U90
cUL listing per UL508A for Canada [requires M23, M43 or M54, plus T58]	U91
Special enclosure paint color [specify color]	Y09
Assembly into transport sections [specify sections]	Y11
1-line label for customer text, 40 x 80 mm [specify text]	Y31
2-line label for customer text, 40 x 180 mm [specify text]	Y32
4-line label for customer text, 40 x 180 mm [specify text]	Y33
Customer drawings in dxf format	D02
Advance copy of customer documentation (pdf)	D14
Documentation English/French	D58
Nameplate English/French	T58
Visual Inspection by customer	F03
Witnessed or observed function test without motor	F71
Witnessed or observed test incl. high-voltage and insulation test	F77
Customer specific test (on request)	F97

1) Only in combination with option **K90** or **K95**.

2) These options are not yet UL listed and cannot be included in a UL listed line-up.

3) Only in combination with option **L37**.



### Options

#### Option combination matrix for Motor Modules Chassis format

The following tables provide an overview of possible and impermissible combinations of standard options. Please refer to the descriptions of options for more information. Custom configurations may be possible to provide combinations not available as standard – please contact the factory.

- ✓ Combination is possible
- Combination is not possible

#### Electrical Options

	G20	G33	K46	K48	K50	K51	K88	K90	K95	L07	L08	L10	L34	L37	L61	L62	L64	L65
G20	✓	–	✓	✓	✓	✓	✓	✓	✓	✓	✓	✓	✓	✓	✓	✓	✓	✓
G33	–	✓	✓	✓	✓	✓	✓	✓	✓	✓	✓	✓	✓	✓	✓	✓	✓	✓
K46	✓	✓	✓	–	–	–	✓	✓	✓	✓	✓	✓	✓	✓	✓	✓	✓	✓
K48	✓	✓	–	✓	–	–	✓	✓	✓	✓	✓	✓	✓	✓	✓	✓	✓	✓
K50	✓	✓	–	–	✓	–	✓	✓	✓	✓	✓	✓	✓	✓	✓	✓	✓	✓
K51	✓	✓	–	–	–	✓	✓	✓	✓	✓	✓	✓	✓	✓	✓	✓	✓	✓
K88	✓	✓	✓	✓	✓	✓	✓	✓	✓	✓	✓	✓	✓	✓	✓	✓	✓	✓
K90	✓	✓	✓	✓	✓	✓	✓	–	–	✓	✓	✓	✓	✓	✓	✓	✓	✓
K95	✓	✓	✓	✓	✓	✓	✓	–	–	✓	✓	✓	✓	✓	✓	✓	✓	✓
L07	✓	✓	✓	✓	✓	✓	✓	✓	✓	✓	–	–	✓	–	✓	✓	✓	✓
L08	✓	✓	✓	✓	✓	✓	✓	✓	✓	–	–	–	✓	✓	✓	✓	✓	✓
L10	✓	✓	✓	✓	✓	✓	✓	✓	✓	–	–	–	–	✓	✓	✓	✓	✓
L34	✓	✓	✓	✓	✓	✓	✓	✓	✓	✓	✓	–	–	✓	✓	✓	✓	✓
L37	✓	✓	✓	✓	✓	✓	✓	✓	✓	–	–	–	–	–	–	–	–	–
L61	✓	✓	✓	✓	✓	✓	✓	✓	✓	✓	✓	✓	–	–	–	–	–	–
L62	✓	✓	✓	✓	✓	✓	✓	✓	✓	✓	✓	✓	–	–	–	–	–	–
L64	✓	✓	✓	✓	✓	✓	✓	✓	✓	✓	✓	✓	–	–	–	–	–	–
L65	✓	✓	✓	✓	✓	✓	✓	✓	✓	✓	✓	✓	–	–	–	–	–	–

#### Mechanical Options

	M06	M07	M21	M23	M43	M54	M59	M60	M90	Y11	U90	U91
M06	✓	–	✓	✓	✓	✓	✓	✓	✓	✓	✓	✓
M07	–	✓	✓	✓	✓	✓	✓	✓	✓	✓	✓	✓
M21	✓	✓	✓	–	–	–	✓	✓	✓	✓	–	–
M23	✓	✓	–	✓	–	–	✓	–	✓	✓	✓	✓
M43	✓	✓	–	–	–	–	✓	–	✓	✓	✓	✓
M54	✓	✓	–	–	–	–	✓	–	✓	✓	✓	✓
M59	✓	✓	✓	✓	✓	✓	–	–	✓	✓	✓	✓
M60	✓	✓	✓	–	–	–	✓	–	✓	✓	–	–
M90	✓	✓	✓	✓	✓	✓	✓	–	–	–	✓	✓
Y11	✓	✓	✓	✓	✓	✓	✓	–	–	–	✓	✓
U90	✓	✓	–	✓	✓	✓	✓	–	–	–	–	–
U91	✓	✓	–	✓	✓	✓	✓	–	–	–	–	–

# SINAMICS S120 Cabinet Modules

## Motor Modules Chassis Format

### Options

#### DC busbar system Options

Within a line-up, all DC bus needs to be of the same width (60, 80 or 100 mm). DC bus current ratings may vary within a line-up by using either a single busbar, or two or three busbars in parallel per pole.

The following table indicates which busbar options for the various cabinet modules may be combined within a line-up.



Combination is possible



Combination is not possible

	M80	M81	M82	M83	M84	M85	M86	M87
M80		-	-	✓	-	-	-	-
M81	-		-	-	✓	-	✓	-
M82	-	-		-	-	✓	-	✓
M83	✓	-	-		-	-	-	-
M84	-	✓	-	-		-	✓	-
M85	-	-	✓	-	-		-	✓
M86	-	✓	-	-	✓	-		-
M87	-	-	✓	-	-	✓	-	

#### Label Options

	Y31	Y32	Y33
Y31		-	-
Y32	-		-
Y33	-	-	

### Overview



Motor Modules are also available as Booksize Cabinet Kits at 380 V to 480 V (DC bus voltage 510 V to 720 V).

The following Motor Modules are available:

- Single Motor Modules for power ratings of 5 to 100 HP (4.8 kW to 82 kW at 400 V) to feed a single motor

### Design

Motor Modules booksize format are configured as Booksize Cabinet Kits, which are then factory mounted in Booksize Base Cabinets that contain all components and wiring necessary for operation (Kits cannot be purchased separately, only mounted in a Booksize Base Cabinet).

Several Booksize Cabinet Kits can be installed in one Booksize Base Cabinet. The number of Booksize Cabinet Kits that can be installed in a Booksize Base Cabinet is determined solely on the basis of the available cabinet width and the width of the kits, which in turn depends on the power rating. The number of Booksize Kits mounted in a specific Base Cabinet must be specified in plain text.

Each Booksize Motor Module is individually connected to the DC bus of the SINAMICS S120 Cabinet Module via fixed mounted fuses. (The DC bus integrated in the Booksize modules is not used).

The basic version of a Booksize Cabinet Kit comprises the following components:

- Motor Module, booksize format
- Fuses for each Motor Module
- Customer terminal interface -X55.1 located in the connection area of the Booksize Base Cabinet
- Shield connection plate
- Complete electrical interconnections to the Booksize Base Cabinet Interfaces

Booksize Base Cabinets can be provided as NEMA 12 ventilated (IP54) enclosures without additional temperature derating. However, note that there are some differences between Booksize and Chassis format Motor Modules with respect to technical data and derating. [Please refer to the engineering information section 7.](#)

### Selection and ordering data

Rated power at 460 (400) V kW	Rated power at 460 V HP	Rated output current $I_N$ A	In-stall. width mm	Single Motor Module Booksize Cabinet Kit Order No.
Line voltage 380 ... 480 V 3ph. AC (DC bus voltage 510 ... 720 V DC)				
5.5 (4.8)	5	9	100	6SL3720-1TE21-0AU3
11 (9.7)	10	18	100	6SL3720-1TE21-8AU3
18 (16)	20	30	100	6SL3720-1TE23-0AU3
28 (24)	30	45	200	6SL3720-1TE24-5AU3
37 (32)	40	60	200	6SL3720-1TE26-0AU3
53 (46)	60	85	200	6SL3720-1TE28-5AU3
82 (71)	100	132	300	6SL3720-1TE31-3AU3

For all Motor Module Booksize Cabinet Kits: SCCR 65 kA\*

Booksize base cabinets for installation of booksize kits.

Usable install. width mm	Weight approx. lb [kg]	Dimensions for base IP20 design (W x D x H) <sup>1)</sup> inch [mm]	Booksize Base Cabinet Order No.
Line voltage 380 ... 480 V 3ph. AC (DC bus voltage 510 ... 720 V DC)			
600	375 [170]	31.5 x 23.6 x 86.6 [800 x 600 x 2,200]	6SL3720-1TX38-0AU3
1,000	520 [240]	47.2 x 23.6 x 86.6 [1,200 x 600 x 2,200]	6SL3720-1TX41-2AU3

<sup>1)</sup> The enclosure height increases by 10" (250 mm) for NEMA 1 (IP21) and by 16" (400 mm) for NEMA 1 filtered (IP23), IP43 and NEMA 12 ventilated (IP54) enclosure.

\* Note that UL listing of Motor Module Booksize Cabinet Kits is not yet complete.

# SINAMICS S120 Cabinet Modules

## Motor Modules Booksize Formats

### Block diagram

Motor Modules are controlled by the CU320-2 DP or CU320-2 PN Control Unit. By selecting option codes K90 or K95 the Control Unit is included in the motor module cabinet, complete with the DRIVE-CLiQ cable connecting it to the motor module. However, if the Control Unit is also used to control other motor modules, or if the Control Unit is to be

mounted separately, the DRIVE-CLiQ cables are excluded need to be added by others.

*For additional information, please refer to the SINAMICS Low Voltage Engineering Manual.*

4

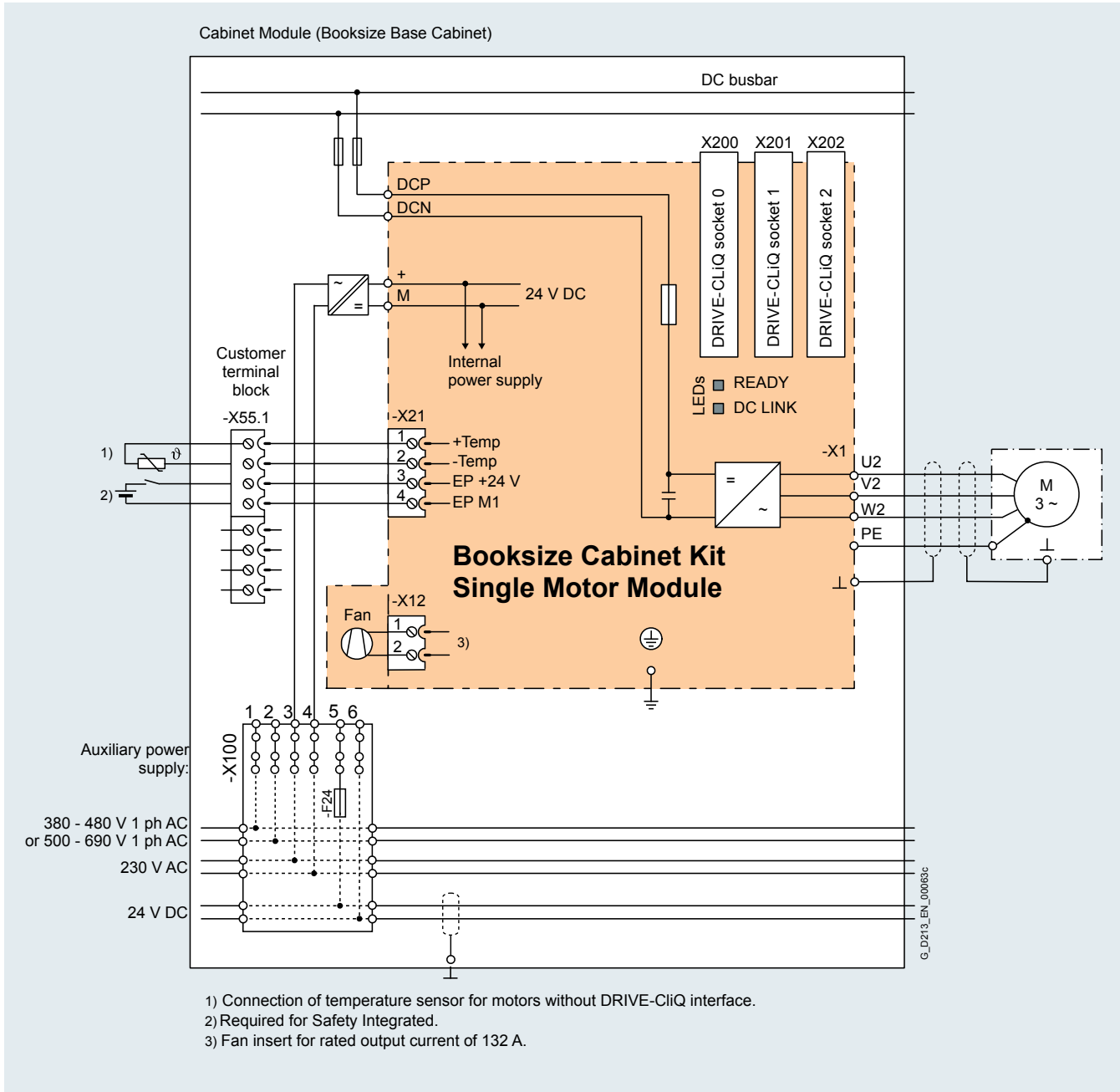

Connection example of a Single Motor Module, Booksize Cabinet Kit format

### Technical data

Line voltage 380 ... 480 V 3 ph. AC DC bus voltage 510 ... 720 V DC	Single Motor Module Booksize Cabinet Kit			
		6SL3720-1TE21-0AU3	6SL3720-1TE21-8AU3	6SL3720-1TE23-0AU3
<b>Rated power</b>				
• For $I_L$ (60 Hz, 460 V) <sup>1) 2)</sup>	kW [HP]	5.5 [5]	11 [10]	18 [20]
• For $I_L$ (50 Hz, 400 V) <sup>1)</sup>	kW	4.8	9.7	16
• For $I_H$ (60 Hz, 460 V) <sup>1) 2)</sup>	kW [HP]	5 [5]	9 [10]	15 [15]
• For $I_H$ (50 Hz, 400 V) <sup>1)</sup>	kW	4.1	8.2	13.7
<b>Output current</b>				
• Rated current $I_{NA}$	A	9	18	30
• Base load current $I_H$ <sup>3)</sup>	A	7.7	15.3	25.5
• Maximum current $I_{maxA}$	A	18	36	56
<b>DC bus current</b> <sup>4)</sup>	A	11	22	36
<b>Current demand</b>				
• 24V DC	A	0.85	0.85	0.9
<b>DC bus capacitance</b>	μF	110	220	710
<b>Pulse frequency</b> <sup>5)</sup>				
• Rated	kHz	4	4	4
• Maximum (with derating)	kHz	16	16	16
<b>Power loss, max.</b> <sup>6)</sup>				
• At 60 Hz 460V [50 Hz 400V]	kW	0.08 [0.08]	0.165 [0.165]	0.29 [0.29]
<b>Cooling air requirement</b>	cfm [m <sup>3</sup> /s]	17 [0.008]	17 [0.008]	34 [0.016]
<b>Sound pressure level <math>L_{pA}</math></b> (1m) at 60 [50] Hz	dB(A)	< 60	< 60	72
<b>Motor connection</b> U2, V2, W2		Terminal	Terminal	Terminal
• Conductor size, max.		#10 AWG	#10 AWG	#10 AWG
<b>Output cable length, max.</b> <sup>7)</sup>				
• Shielded	ft [m]	164 [50]	230 [70]	328 [100]
• Unshielded	ft [m]	246 [75]	328 [100]	492 [150]
<b>Weight, approx.</b>	lb [kg]	44 [20]	44 [20]	48 [21.9]
<b>Installation width</b>	mm	100	100	100
<b>Short Circuit Current Rating (SCCR)</b> per UL508A	kA	65	65	65

- 1) Rated power in kW is of a typical 6-pole standard induction motor with an FLA of  $I_L$  or  $I_H$  at the listed voltage and frequency.
- 2) Rated power in HP is based on NEC table 430-150. Note that **HP ratings are provided as a guide only**, for standard 2, 4 or 6 pole motors. Actual motor currents may be higher, especially for motors with 8 or more poles.
- 3) The base load current  $I_H$  is the basis for a duty cycle of duration of 300 s with an overload of 150 % for 60 s or 160 % for 10 s.
- 4) For a DC bus voltage of 600 V DC.
- 5) Information regarding the correlation between the pulse frequency and max. output current/output frequency is provided in the SINAMICS Low Voltage Engineering Manual.
- 6) The specified power loss represents the maximum value at 100 % utilization. The value is lower under normal operating conditions.
- 7) Sum of lengths of all motor cables. Longer cable lengths for specific configurations may be available on request. **For additional information, please refer to the SINAMICS Low Voltage Engineering Manual.**

# SINAMICS S120 Cabinet Modules

## Motor Modules Booksize Formats

### Technical data

Line voltage 380 ... 480 V 3 ph. AC DC bus voltage 510 ... 720 V DC		Single Motor Module Booksize Cabinet Kit			
		6SL3720-1TE24-5AU3	6SL3720-1TE26-0AU3	6SL3720-1TE28-5AU3	6SL3720-1TE31-3AU3
<b>Rated power</b>					
• For $I_L$ (60 Hz, 460 V) <sup>1) 2)</sup>	kW [HP]	28 [30]	37 [40]	53 [60]	82 [100]
• For $I_L$ (50 Hz, 400 V) <sup>1)</sup>	kW	24	32	46	71
• For $I_H$ (60 Hz, 460 V) <sup>1) 2)</sup>	kW [HP]	24 [25]	32 [40]	42 [50]	65 [75]
• For $I_H$ (50 Hz, 400 V) <sup>1)</sup>	kW	21	28	37	57
<b>Output current</b>					
• Rated current $I_{NA}$	A	45	60	85	132
• Base load current $I_H$ <sup>3)</sup>	A	38	52	68	105
• Maximum current $I_{maxA}$	A	85	113	141	210
<b>DC bus current <math>I_d</math> <sup>4)</sup></b>	A	54	72	102	158
<b>Current demand</b>					
• 24V DC	A	1.2	1.2	1.5	1.5
<b>DC bus capacitance</b>	μF	1,175	1,410	1,880	2,820
<b>Pulse frequency <sup>5)</sup></b>					
• Rated	kHz	4	4	4	4
• Maximum (with derating)	kHz	16	16	16	16
<b>Power loss, max. <sup>6)</sup></b>					
• At 60 Hz 475V [50 Hz 400V]	kW	0.43 [0.43]	0.59 [0.59]	0.75 [0.75]	1.25 [1.25]
<b>Cooling air requirement</b>	cfm [m <sup>3</sup> /s]	65.7 [0.031]	65.7 [0.031]	93.2 [0.044]	305 [0.144]
<b>Sound pressure level <math>L_{pA}</math> (1m) at 60 [50] Hz</b>	dB(A)	< 65	< 65	< 60	< 73
<b>Motor connection U2, V2, W2</b>					
• Conductor size, max.		Terminal #6 AWG	Terminal #6 AWG	Terminal 2/0	Terminal 2/0
<b>Output cable length, max. <sup>7)</sup></b>					
• Shielded	ft [m]	328 [100]	328 [100]	328 [100]	328 [100]
• Unshielded	ft [m]	492 [150]	492 [150]	492 [150]	492 [150]
<b>Weight, approx.</b>	lb [kg]	60 [27]	60 [27]	73 [33]	90 [41]
<b>Installation width</b>	mm	200	200	200	300
<b>Short Circuit Current Rating (SCCR) per UL508A</b>	kA	65	65	65	65

1) Rated power in kW is of a typical 6-pole standard induction motor with an FLA of  $I_L$  or  $I_H$  at the listed voltage and frequency.

2) Rated power in HP is based on NEC table 430-150. Note that **HP ratings are provided as a guide only**, for standard 2, 4 or 6 pole motors. Actual motor currents may be higher, especially for motors with 8 or more poles.

3) The base load current  $I_H$  is the basis for a duty cycle of duration of 300 s with an overload of 150 % for 60 s or 160 % for 10 s.

4) For a DC bus voltage of 600 V DC.

5) Information regarding the correlation between the pulse frequency and max. output current/output frequency is provided in the SINAMICS Low Voltage Engineering Manual.

6) The specified power loss represents the maximum value at 100 % utilization. The value is lower under normal operating conditions.

7) Sum of lengths of all motor cables. Longer cable lengths for specific configurations may be available on request. **For additional information, please refer to the SINAMICS Low Voltage Engineering Manual.**

### Options

The table below lists the available options for Motor Modules booksize format (refer to **Description of the Options** for details).

Motor Module Booksize Cabinet Kits Available Options	Option code
CBC10 Communication Board (CANbus)	G20 <sup>1)</sup>
CBE20 Communication Board (Ethernet)	G33 <sup>1)</sup>
Safety license for 1 to 5 axes	K01 to K05
AOP30 Advanced Operator Panel installed in the cabinet door	K08 <sup>1)</sup>
SMC10 Sensor Module Cabinet-Mounted	K46
SMC20 Sensor Module Cabinet-Mounted	K48
SMC30 Sensor Module Cabinet-Mounted	K50
VSM10 Voltage Sensing Module	K51
Additional SMC30 Sensor Module	K52
Terminal interface for the Safe Torque Off and Safe Stop 1 safety functions	K82
TM54F Terminal Module	K87
CU320-2 DP Control Unit (PROFIBUS DP)	K90
Performance expansion for CU320-2	K94 <sup>1)</sup>
CU320-2 PN Control Unit (PROFINET)	K95
Motor reactor	L08
2 motor reactors in series	L09
DC disconnect with pre-charge circuit for the associated DC bus capacitance (includes M60)	L37 <sup>2)</sup>
UL listing per UL508A	U90 <sup>3)</sup>
cUL listing per UL508A for Canada	U91 <sup>3)</sup>

Booksize Base Cabinets Available Options	Option code
Enclosure space heater	L55
Base (plinth) 100mm	M06
Base (plinth) 200mm (cable marshalling space)	M07
Enclosure NEMA 1 (IP21)	M21
Enclosure NEMA 1 filtered (IP23) [includes M60]	M23
Side panel (right)	M26
Side panel (left)	M27
Enclosure IP43 [includes M60]	M43
Enclosure NEMA 12 (ventilated) (IP54) [includes M60]	M54
Solid cabinet door (no ventilation openings, air inlet through floor)	M59
EMC shield bus (for connecting cable screens)	M70
DC busbar system ( $I_d = 1,170$ A, 1x 60 x 10 mm)	M80
DC busbar system ( $I_d = 1,500$ A, 1x 80 x 10 mm)	M81
DC busbar system ( $I_d = 1,840$ A, 1x 100 x 10 mm)	M82
DC busbar system ( $I_d = 2,150$ A, 2x 60 x 10 mm)	M83
DC busbar system ( $I_d = 2,730$ A, 2x 80 x 10 mm)	M84
DC busbar system ( $I_d = 3,320$ A, 2x 100 x 10 mm)	M85
DC busbar system ( $I_d = 3,720$ A, 3x 80 x 10 mm)	M86
DC busbar system ( $I_d = 4,480$ A, 3x 100 x 10 mm)	M87
Lifting beam/eye bolts	M90
UL listing per UL508A [requires M23, M43 or M54]	U90 <sup>3)</sup>
cUL listing per UL508A for Canada [requires M23, M43 or M54, plus T58]	U91 <sup>3)</sup>
Special enclosure paint color [specify color]	Y09
Assembly into transport sections [specify sections]	Y11
1-line label for customer text, 40 x 80 mm [specify text]	Y31
2-line label for customer text, 40 x 180 mm [specify text]	Y32
4-line label for customer text, 40 x 180 mm [specify text]	Y33
Customer drawings in dxf format	D02
Advance copy of customer documentation (pdf)	D14
Documentation English/French	D58
Nameplate English/French	T58
Visual Inspection by customer	F03
Witnessed or observed function test without motor	F71
Witnessed or observed test incl. high-voltage and insulation test	F77
Customer specific test (on request)	F97

<sup>1)</sup> Only in combination with option K90 or K95.

<sup>2)</sup> Option L37 is not UL listed and cannot be included in a UL listed line-up.

<sup>3)</sup> Consult factory for availability of these options.

# SINAMICS S120 Cabinet Modules

## Motor Modules Booksize Formats

### Options

#### Option combination matrix for Booksize Cabinet Kits and Booksize Base Cabinets

The following tables provide an overview of possible and impermissible combinations of standard options. Please refer to the descriptions of options for more information. Custom configurations may be possible to provide combinations not available as standard – please contact the factory.



Combination is possible



Combination is not possible

#### Electrical Options for Booksize Cabinet Kits

	G20	G33	K46	K48	K50	K51	K90	K95	L08	L09
G20		-	✓	✓	✓	✓	✓	✓	✓	✓
G33	-		✓	✓	✓	✓	✓	✓	✓	✓
K46	✓	✓		✓	-	-	✓	✓	✓	✓
K48	✓	✓	-		-	-	✓	✓	✓	✓
K50	✓	✓	-	-		-	✓	✓	✓	✓
K51	✓	✓	-	-	-		✓	✓	✓	✓
K90	✓	✓	✓	✓	✓	✓		-	✓	✓
K95	✓	✓	✓	✓	✓	✓	-		✓	✓
L08	✓	✓	✓	✓	✓	✓	✓	✓		-
L09	✓	✓	✓	✓	✓	✓	✓	✓	-	

#### Mechanical Options

	M06	M07	M21	M23	M43	M54	M59	M60	M90	Y11	U90 <sup>1)</sup>	U91 <sup>1)</sup>
M06		-	✓	✓	✓	✓	✓	✓	✓	✓	✓	✓
M07	-		✓	✓	✓	✓	✓	✓	✓	✓	✓	✓
M21	✓	✓		-	-	-	✓	✓	✓	✓	-	-
M23	✓	✓	-		-	-	✓	-	✓	✓	✓	✓
M43	✓	✓	-	-		-	✓	-	✓	✓	✓	✓
M54	✓	✓	-	-	-		✓	-	✓	✓	✓	✓
M59	✓	✓	✓	✓	✓	✓		✓	✓	✓	✓	✓
M60	✓	✓	✓	-	-	-	✓		✓	✓	-	-
M90	✓	✓	✓	✓	✓	✓	✓	✓		-	✓	✓
Y11	✓	✓	✓	✓	✓	✓	✓	✓	-		✓	✓
U90 <sup>1)</sup>	✓	✓	-	✓	✓	✓	✓	-	✓	✓		-
U91 <sup>1)</sup>	✓	✓	-	✓	✓	✓	✓	-	✓	✓	-	

1) Consult factory for availability of these options.



### Options

#### DC busbar system Options

Within a line-up, all DC bus needs to be of the same width (60, 80 or 100 mm). DC bus current ratings may vary within a line-up by using either a single busbar, or two or three busbars in parallel per pole.

The following table indicates which busbar options for the various cabinet modules may be combined within a line-up.

- ✓ Combination is possible
- Combination is not possible

	M80	M81	M82	M83	M84	M85	M86	M87
M80		–	–	✓	–	–	–	–
M81	–		–	–	✓	–	✓	–
M82	–	–		–	–	✓	–	✓
M83	✓	–	–		–	–	–	–
M84	–	✓	–	–		–	✓	–
M85	–	–	✓	–	–		–	✓
M86	–	✓	–	–	✓	–		–
M87	–	–	✓	–	–	✓	–	

#### Label Options

	Y31	Y32	Y33
Y31		–	–
Y32	–		–
Y33	–	–	

# SINAMICS S120 Cabinet Modules

## Braking Modules (Chassis Mounted)

### Overview

Braking Modules are required to remove energy from the DC bus to brake overhauling loads if the Line Module is not capable of regenerative operation, or to enable electrical braking even in the event of a power supply failure.

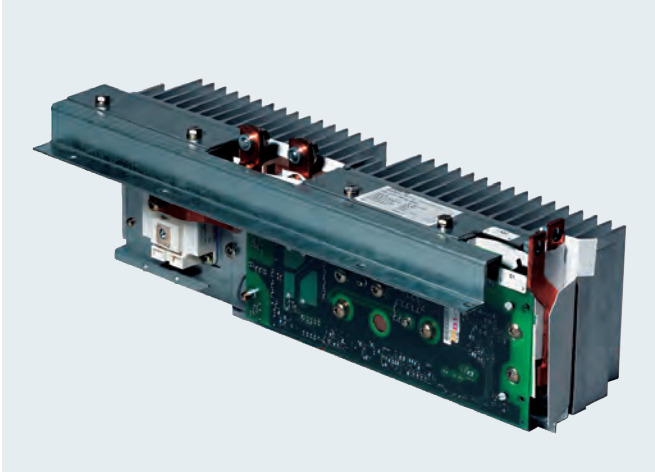

Braking modules mounted inside chassis

For lower braking powers, Braking Modules are available for mounting inside chassis format Line and Motor Modules (options L61 to L65), and they are cooled by the fans on these modules. The Braking Module includes the power electronics and the associated control circuit. The supply voltage for the electronics is taken from the DC bus. The Braking Module works autonomously from the drive control. During operation, the DC bus energy is converted to heat in a matching external braking resistor which is supplied as a loose component for external mounting by others.

Several Braking Modules can be operated in parallel, but a separate braking resistor must be connected to each Braking Module.

The activation threshold voltage of the Braking Module can be adjusted by means of a DIP switch. The braking power values specified in the technical specifications apply to the upper activation threshold.



Matching braking resistors

Each braking module requires a matching braking resistor. The maximum permissible cable length between the Braking Module and braking resistor is 330 ft (100 m). The braking resistor is monitored on the basis of the duty cycle. A temperature switch (NC contact) is also fitted. This responds when the maximum permissible temperature is exceeded and can be evaluated by a controller.

For additional information, please refer to the [Description of the Options \(L61, L62, L64, L65\)](#), or the [SINAMICS Low Voltage Engineering Manual](#).

# SINAMICS S120 Cabinet Modules

## Braking Modules (Chassis Mounted)

### Technical data

		Braking Module and Braking Resistor					
Option code		L61	L62	L64	L65	L61	L62
Motor or Line Modules frame size		FX/FB	GX/GB, HX, JX	FX/FB	GX/GB, HX, JX	FX/FB	GX/GB, HX, JX
Line voltage		380 ... 480 V 3 ph. AC		500 ... 600 V 3 ph. AC		660 ... 690 V 3 ph. AC	
DC bus voltage		510 ... 720 V DC		675 ... 900 V DC		890 ... 1,035 V DC	
<b>Braking Module</b>							
Rated power							
• Rated power $P_{DB}$	kW	25	50	25	50	25	50
• Peak power $P_{15}$	kW	125	250	125	250	125	250
• Power $P_{20}$	kW	100	200	100	200	100	200
• Power $P_{40}$	kW	50	100	50	100	50	100
Activation thresholds (adjustable via DIP switch)	V	774 (factory setting) or 673		967 (factory setting) or 841		1,153 (factory setting) or 1,070	
<b>Resistor Connection</b>		M8 nut	M8 nut	M8 nut	M8 nut	M8 nut	M8 nut
• Max. wire size	AWG/MCM	#2 AWG	#1 AWG	#2 AWG	#1 AWG	#2 AWG	#1 AWG
<b>Braking Resistor</b>							
<b>Resistance</b>	$\Omega$	4.4 ( $\pm 7.5\%$ )	2.2 ( $\pm 7.5\%$ )	6.8 ( $\pm 7.5\%$ )	3.4 ( $\pm 7.5\%$ )	9.8 ( $\pm 7.5\%$ )	4.9 ( $\pm 7.5\%$ )
<b>Rated power</b>							
• Rated power $P_{DB}$ (continuous)	kW	25	50	25	50	25	50
• Peak power $P_{15}$ (maximum)	kW	125	250	125	250	125	250
• Power $P_{20}$	kW	100	200	100	200	100	200
• Power $P_{40}$	kW	50	100	50	100	50	100
<b>Current, max.</b>	A	189	378	153	305	125	255
<b>Power connection</b>		M10 stud	M10 stud	M10 stud	M10 stud	M10 stud	M10 stud
<b>Enclosure</b>		IP20	IP20	IP20	IP20	IP20	IP20
<b>Enclosure dimensions, nominal</b>							
• Width	inch [mm]	29 [740]	32 [810]	29 [740]	32 [810]	29 [740]	32 [810]
• Height	inch [mm]	24 [600]	52 [1,325]	24 [600]	52 [1,325]	24 [600]	52 [1,325]
• Depth	inch [mm]	19 [486]	19 [486]	19 [486]	19 [486]	19 [486]	19 [486]
<b>Weight, approx.</b>	lb [kg]	110 [50]	265 [120]	110 [50]	265 [120]	110 [50]	265 [120]

## Motor Modules used as Braking Modules

### Overview



For applications requiring high or very high braking powers, Motor Modules in Chassis format can be configured as 3-phase Braking Modules.

When used as a braking module, three identical braking resistors in a wye connection are connected to the output of the Motor Module instead of a motor. These resistors form a symmetrical resistive load. Three individual resistors in separate enclosures or a symmetrical 3-phase resistor in one enclosure may be used. (It is not permissible to use asymmetrical or single phase resistor arrangements).

SINAMICS S120 firmware (Version 4.4 and up) includes standard functionality to parameterize a motor module for operation with a braking resistor. Settings include the resistance of the braking resistor, the activation threshold voltage and the output voltage.

### Design

The permissible output currents for application as Braking Modules (rated continuous  $I_{\text{rated-Brake}}$ , and maximum  $I_{\text{max-Brake}}$  braking current) is provided on the following page. These values are based on the upper response thresholds, (i.e. to  $V_{\text{DC-max}} = 774 \text{ V}$  at line supply voltages of 380 V to 480 V and to  $V_{\text{DC-max}} = 967 \text{ V}$  (1158 V) at line supply voltages of 500 V to 600 (690) V. For other response thresholds, the braking power must be reduced in proportion to  $V_{\text{DC-Brake}}$ .

The braking power  $P_{\text{Brake}}$  of a Motor Module operating as a Braking Module is proportional to the DC bus voltage during braking. This response threshold  $V_{\text{DC-Brake}}$  can be freely selected, but should be limited to the range specified in the table below for the relevant line connection voltage.

Note that for Motor Modules operating as Braking Modules the response time at about 4 to 5 ms is approximately twice as long as of the smaller Braking Modules designed for mounting in chassis (and of the Central Braking Modules offered in the IEC product spectrum of SINAMICS S120 Cabinet Modules). For applications that require a very fast braking response time it may therefore be necessary to combine both types of Braking Modules in one system. Please consult the factory when engineering such an application.

For additional information, please refer to the [SINAMICS Low Voltage Engineering Manual](#).

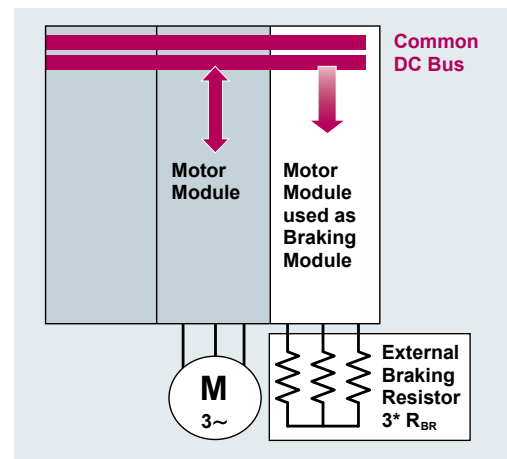

Due to the large range of braking powers and as Braking Resistors at high and very high powers generally require special designs (for example, outdoor installation or water cooling), such resistors are not offered as standard components in this catalog. Please consult with specialized resistor manufacturers to select suitable components.

Line voltage	Threshold voltage range $V_{\text{DC-Brake}}$
380 ... 480 V 3 ph. AC	673 ... 774 V
500 ... 600 (690) V 3 ph. AC	841 ... 967 V (1,070 ... 1,158 V)

The minimum cable length to the braking resistors is 33 ft. (10 m). If shorter cables are used, the motor module requires a motor reactor (option L08).

The maximum cable length is 980 ft (300 m) with shielded cables and 1,480 ft (450 m) with unshielded cables, corresponding to the maximum cable lengths for Motor Modules used for their standard purpose.

### Technical data

Braking power ratings below are provided as a guide only. Please refer to the SINAMICS Engineering Manual for additional information and details of calculations. Values are also dependant on the characteristics of braking resistors selected (such as tolerances and increase of resistance under load).

Motor Module chassis format	Rated output current (used as motor module) $I_N$	Motor Module used as Braking Module				
		Continuous braking current $I_{\text{rated-Brake}}$	Maximum braking current $I_{\text{max-Brake}}$	Continuous braking power $P_{\text{rated-Brake}}^{1)}$	Peak braking power $P_{\text{max-Brake}}^{1)}$	Minimum braking resistance $R_{\text{BR-min}}^{2)}$
Order No.	[A]	[A]	[A]	[kW]	[kW]	[Ω]
Line voltage 380 ... 480 V 3ph. AC (DC bus voltage 510 ... 650 V DC)						
6SL3720-1TE32-1AU3	210	210	307	197	288	1.02
6SL3720-1TE32-6AU3	260	255	368	239	345	0.85
6SL3720-1TE33-1AU3	310	290	424	272	398	0.74
6SL3720-1TE33-8AU3	380	340	497	319	466	0.63
6SL3720-1TE35-0AU3	490	450	657	422	617	0.48
6SL3720-1TE36-1AU3	605	545	797	511	748	0.39
6SL3720-1TE37-5AU3	745	680	993	638	932	0.32
6SL3720-1TE38-4AU3	840	800	1,171	751	1,099	0.27
6SL3720-1TE41-0AU3	985	900	1,316	845	1,235	0.24
6SL3720-1TE41-2AU3	1,260	1,215	1,779	1,140	1,669	0.18
6SL3720-1TE41-4AU3	1,405	1,365	1,996	1,281	1,873	0.16
Line voltage 500 ... 600 (690) V 3ph. AC (DC bus voltage 675 ... 810 (930) V DC)						
6SL3720-1TG28-5AU3	85	85	120	99 (119)	140 (168)	3.26 (3.90)
6SL3720-1TG31-0AU3	100	100	142	117 (140)	166 (199)	2.75 (3.30)
6SL3720-1TG31-2AU3	120	115	165	134 (161)	194 (232)	2.37 (2.84)
6SL3720-1TG31-5AU3	150	144	204	168 (202)	239 (286)	1.92 (2.29)
6SL3720-1TG31-8AU3	175	175	255	205 (246)	299 (358)	1.53 (1.84)
6SL3720-1TG32-2AU3	215	215	312	252 (302)	366 (438)	1.25 (1.50)
6SL3720-1TG32-6AU3	260	255	368	299 (358)	432 (517)	1.06 (1.27)
6SL3720-1TG33-3AU3	330	290	422	340 (407)	494 (592)	0.93 (1.11)
6SL3720-1TG34-1AU3	410	400	585	469 (562)	686 (821)	0.67 (0.80)
6SL3720-1TG34-7AU3	465	450	656	528 (632)	769 (921)	0.60 (0.71)
6SL3720-1TG35-8AU3	575	515	752	604 (723)	882 (1,056)	0.52 (0.62)
6SL3720-1TG37-4AU3	735	680	985	797 (955)	1,155 (1,383)	0.40 (0.48)
6SL3720-1TG38-1AU3	810	805	1,178	944 (1,130)	1,381 (1,654)	0.33 (0.40)
6SL3720-1TG38-8AU3	910	905	1,313	1,061 (1,271)	1,539 (1,843)	0.30 (0.36)
6SL3720-1TG41-0AU3	1,025	1,020	1,493	1,196 (1,432)	1,750 (2,096)	0.26 (0.31)
6SL3720-1TG41-3AU3	1,270	1,230	1,787	1,442 (1,727)	2,095 (2,509)	0.22 (0.26)

- 1) Power at upper (maximum) response threshold voltage: For line voltage 380 ... 480 V = 774 V, for 500 ... 600 (690) V = 967 (1,158) V. Power ratings reduce for lower threshold setting.
- 2) Minimum braking resistance (cold state) per phase (i.e. per resistor, using three resistors in wye connection). Calculations must make allowance for the increase in resistance under load (up to approx. 30%).

# SINAMICS S120 Cabinet Modules

Notes

4

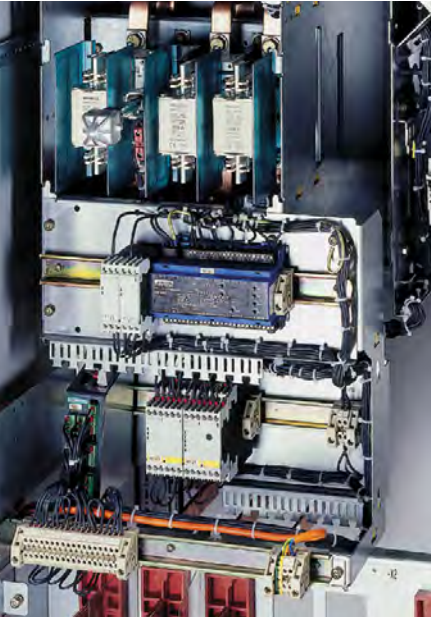

<b>5/2</b>	<b>Auxiliary Power Supply Modules</b> Overview Design Selection and ordering data Block diagram Technical data Options
<b>5/6</b>	<b>Custom Cabinet Modules</b> Custom options Custom Cabinet Modules Custom Cabinet Module line-ups Empty Cabinet Modules
<b>5/8</b>	<b>Integration Engineering</b> Overview Selection and ordering data Options
<b>5/9</b>	<b>Description of Options</b> Communication & control options +G.., +K.. Electrical options +L.. Mechanical options +M.. Other options +P., +U., +Y..

## Auxiliary Power Supply Modules

### Overview



An Auxiliary Power Supply Module is a convenient central source of the entire auxiliary and control power supplies (line voltage, 240 V 1 ph. AC and 24 V DC) for a SINAMICS S120 Cabinet Module line-up. It is generally supplied by a feeder separate from the main feeder(s) to the Line Connection Module(s) of the line up.

Equipment connected to the auxiliary power supply system includes the fans of the SINAMICS S120 power modules, and the control equipment. Since it is fed from a source separate from the main supply, 24 V DC power can be provided to the control electronics even if the DC bus is not charged, for example to maintain PROFIBUS or PROFINET communication.

### Alternatives to Auxiliary Power Supply Modules

An Auxiliary Power Supply Module is not essential; there are various alternative methods of providing auxiliary power to a line-up:

- External auxiliary and control power provided by the customer, for example from an MCC and/or UPS
- For smaller line-ups, it may be possible to include the auxiliary power supplies in the Line Connection Module (by selecting option code K76)
- Another alternative is to include only the source of auxiliary power for the cooling fans in the Line Connection Module (option code K70). The 230 V AC and 24 V DC control supplies would then be provided from an external source, for example from a secure supply with batteries

### Design

The Auxiliary Power Supply Module is supplied from the same voltage level as the main power supply to the line-up..

The standard version contains the following components:

- Circuit breaker disconnect with auxiliary contacts for external monitoring
- Transformer with 230 V output voltage
- SITOP 24 V DC power supply
- Ground bus, including jumper for looping through to the next Cabinet Module
- The module outputs three fused auxiliary voltages:
  - 24 V DC for the electronics power supply
  - 230 V 1 phase AC to supply 230 V loads
  - 380 V to 690 V 1 phase AC to supply the equipment fans

The auxiliary voltages are distributed throughout the line-up via the pre-wired 6-pole auxiliary power supply system, which includes plug connections for looping through from one Cabinet Module to the next.

### Selection and ordering data

Line side supply current rating (380 ... 600 (690) V 3 phase AC) A	Single Motor Module Booksize Cabinet Kit Order No.
125	6SL3700-0MX14-0AU3
160	6SL3700-0MX16-3AU3
200	6SL3700-0MX21-0AU3
250	6SL3700-0MX21-4AU3



### Block diagram

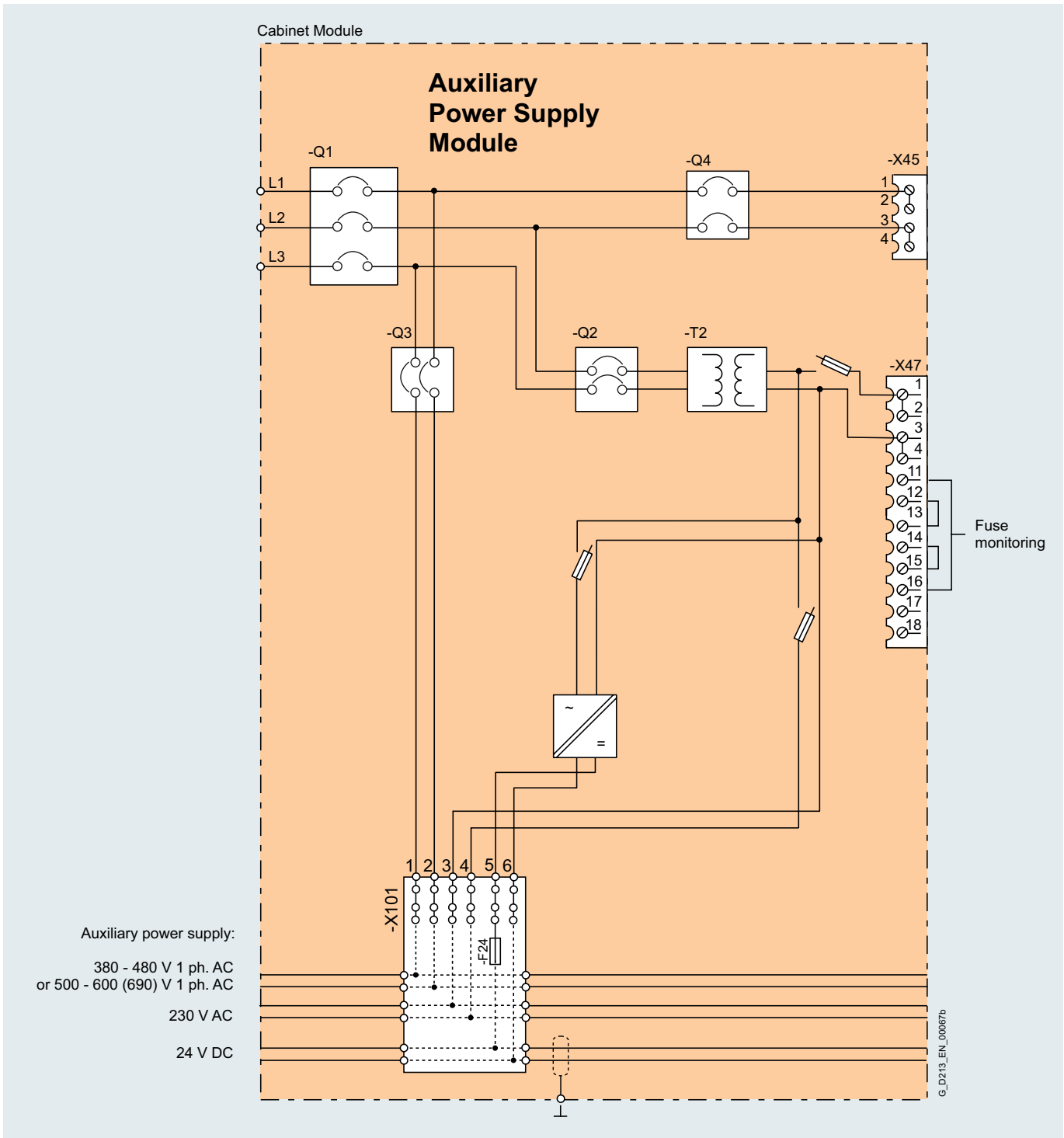

Block diagram, Auxiliary Power Supply Module

# SINAMICS S120 Cabinet Modules

## Auxiliary Power Supply Modules

### Technical data

		Auxiliary Power Supply Modules			
		6SL3700-0MX14-0AU3	6SL3700-0MX16-3AU3	6SL3700-0MX21-0AU3	6SL3700-0MX21-4AU3
<b>Line supply current rating (380 ... 600 (690) V 3 ph. AC)</b>	A	<b>125</b>	<b>160</b>	<b>200</b>	<b>250</b>
<b>Line side power connection</b>					
• Wire size, max.	AWG/MCM	300 MCM	300 MCM	300 MCM	300 MCM
<b>Current carrying capacity, max.</b>					
• Load connection 380 ... 690 V AC					
- to auxiliary power supply	A	63	80	100	100
- to customer terminal -X45	A	50	63	80	80
• Load connection 230 V 1 ph. AC					
- to auxiliary power supply	A	6	10	10	20
- to customer terminal -X45	A	8	10	10	20
• Load connection 24 V DC					
- to auxiliary power supply	A	20	40	80	80
<b>Short Circuit Current Rating (SCCR) per UL508A</b>	kA	100	100	100	100
<b>Wire size, max.</b>					
• Connection -X45	AWG/MCM	#6 AWG	#6 AWG	#6 AWG	#6 AWG
• Connection -X47	AWG/MCM	#14 AWG	#14 AWG	#14 AWG	#14 AWG
<b>Cooling air requirement</b>	cfm	N/A - Natural convection	N/A - Natural convection	N/A - Natural convection	N/A - Natural convection
<b>Ground (PE) connection</b>		Ground bus	Ground bus	Ground bus	Ground bus
<b>Enclosure (base design)</b>		IP20	IP20	IP20	IP20
<b>Enclosure dimensions</b>					
• Width	inch [mm]	24 [600]	24 [600]	24 [600]	24 [600]
• Height <sup>1)</sup>	inch [mm]	87 [2,200]	87 [2,200]	87 [2,200]	87 [2,200]
• Depth	inch [mm]	24 [600]	24 [600]	24 [600]	24 [600]
<b>Weight approx.</b>	lb [kg]	375 [170]	400 [180]	465 [210]	530 [240]

<sup>1)</sup> The enclosure height increases by 10" (250 mm) for NEMA 1 (IP21) and by 16" (400 mm) for NEMA 1 filtered (IP23), IP43 and NEMA 12 ventilated (IP54) enclosure.

### Options

The table below lists the available options for Motor Modules chassis format (refer to **Description of the Options** for details).

Booksize Base Cabinets Available Options	Option code
Enclosure space heater	L55
Base (plinth) 100mm	M06
Base (plinth) 200mm (cable marshalling space)	M07
Enclosure NEMA 1 (IP21)	M21
Enclosure NEMA 1 filtered (IP23) [includes M60]	M23
Side panel (right)	M26
Side panel (left)	M27
Enclosure IP43 [includes M60]	M43
Enclosure NEMA 12 (ventilated) (IP54) [includes M60]	M54
Solid cabinet door (no ventilation openings, air inlet through floor)	M59
EMC shield bus (for connecting cable screens)	M70
DC busbar system ( $I_d = 1,170$ A, 1x 60 x 10 mm)	M80
DC busbar system ( $I_d = 1,500$ A, 1x 80 x 10 mm)	M81
DC busbar system ( $I_d = 1,840$ A, 1x 100 x 10 mm)	M82
DC busbar system ( $I_d = 2,150$ A, 2x 60 x 10 mm)	M83
DC busbar system ( $I_d = 2,730$ A, 2x 80 x 10 mm)	M84
DC busbar system ( $I_d = 3,320$ A, 2x 100 x 10 mm)	M85
DC busbar system ( $I_d = 3,720$ A, 3x 80 x 10 mm)	M86
DC busbar system ( $I_d = 4,480$ A, 3x 100 x 10 mm)	M87
Lifting beam/eye bolts	M90
UL listing per UL508A [requires M23, M43 or M54]	U90
cUL listing per UL508A for Canada [requires M23, M43 or M54, plus T58]	U91
Special enclosure paint color [specify color]	Y09
Assembly into transport sections [specify sections]	Y11
1-line label for customer text, 40 x 80 mm [specify text]	Y31
2-line label for customer text, 40 x 180 mm [specify text]	Y32
4-line label for customer text, 40 x 180 mm [specify text]	Y33
Customer drawings in dxf format	D02
Advance copy of customer documentation (pdf)	D14
Documentation English/French	D58
Nameplate English/French	T58
Visual Inspection by customer	F03
Witnessed or observed function test without motor	F71
Witnessed or observed test incl. high-voltage and insulation test	F77
Customer specific test (on request)	F97

# SINAMICS S120 Cabinet Modules

## Auxiliary Power Supply Modules

### Options

#### Option combination matrix for Auxiliary Power Supply Modules

The following tables provide an overview of possible and impermissible combinations of standard options. Please refer to the descriptions of options for more information. Custom configurations may be possible to provide combinations not available as standard – please contact the factory.

- ✓ Combination is possible
- Combination is not possible

#### Mechanical Options

	M06	M07	M21	M23	M43	M54	M59	M60	M90	Y11	U90	U91
M06		–	✓	✓	✓	✓	✓	✓	✓	✓	✓	✓
M07	–		✓	✓	✓	✓	✓	✓	✓	✓	✓	✓
M21	✓	✓		–	–	–	✓	✓	✓	✓	–	–
M23	✓	✓	–		–	–	✓	–	✓	✓	✓	✓
M43	✓	✓	–	–		–	✓	–	✓	✓	✓	✓
M54	✓	✓	–	–	–		✓	–	✓	✓	✓	✓
M59	✓	✓	✓	✓	✓	✓		✓	✓	✓	✓	✓
M60	✓	✓	✓	–	–	–	✓		✓	✓	–	–
M90	✓	✓	✓	✓	✓	✓	✓	✓		–	✓	✓
Y11	✓	✓	✓	✓	✓	✓	✓	✓	–		✓	✓
U90	✓	✓	–	✓	✓	✓	✓	–	✓	✓		–
U91	✓	✓	–	✓	✓	✓	✓	–	✓	✓	–	

#### DC busbar system Options

Within a line-up, all DC bus needs to be of the same width (60, 80 or 100 mm). DC bus current ratings may vary within a line-up by using either a single busbar, or two or three busbars in parallel per pole.

The following table indicates which busbar options for the various cabinet modules may be combined within a line-up.

	M80	M81	M82	M83	M84	M85	M86	M87
M80		–	–	✓	–	–	–	–
M81	–		–	–	✓	–	✓	–
M82	–	–		–	–	✓	–	✓
M83	✓	–	–		–	–	–	–
M84	–	✓	–	–		–	✓	–
M85	–	–	✓	–	–		–	✓
M86	–	✓	–	–	✓	–		–
M87	–	–	✓	–	–	✓	–	

#### Label Options

	Y31	Y32	Y33
Y31		–	–
Y32	–		–
Y33	–	–	

### Customization of Cabinet Modules

Standard Cabinet Modules with their extensive range of standard options cover a broad range of applications and designs, but there are invariably additional demands to meet project, site or application specific needs. Siemens offers a range of approaches to address such needs, which includes:

#### Custom Options

Custom options are modifications to standard Cabinet Modules and may include, for example:

- **Top cable entry for motor cables:**  
Depending on the frame size and rating of the Motor Module, and the installed options, connections for top entry of motor cables can sometimes be installed inside the standard cabinet, sometimes an additional cabinet may be required.
- **DC bus transition for back-to-back arrangement of Cabinet Modules:**  
A range of DC bus transition designs has been supplied, to best match specific designs and site layouts. Transition connection can be provided in the middle or at the ends of a line-up, sometimes inside existing cabinet modules, sometimes using additional cabinets, or even inside a box bolted to the line-up.
- **Additional control or power components**  
These may include items such as I/O modules for digital and/or analog inputs and outputs, or feeders for motor blower circuits.

#### Custom Cabinet Modules

Custom Cabinet Modules for both power and control circuits are designed, built and tested in the factory. For instance:

- **Contactors and switching Modules**  
A Motor Module may be switched to various motors, for example processes powered by specific motors run at different times, or if individual motors are only briefly used during the day, then costs and space can be saved by using just one inverter with output switches. One such application is pump drives on tankers where various compartments in the ship are emptied one after the other. Another application involves container cranes, where a single inverter may feed motors for hoisting and for the boom.
- **Motor Protection Panel (MPP) Modules**  
Applications such as roller tables in the metals industry may have multiple small motors running on a single Motor Module (group drives). Motor Protection Panels include control and protection devices for, and cable connections for power distribution to multiple motors connected to a common Motor Module.
- **Control Unit Cabinet Modules**  
There are standard options for including control units and encoder modules in the Motor Modules. However, the preference may be to install this control equipment in a central control cabinet that does not contain any power circuits and dangerous voltages associated with them. Such an arrangement is easily implemented due to the great flexibility provided by the DRIVE-CLiQ topology of SINAMICS S120.

#### Custom Cabinet Module line-ups

It is also possible to provide completely custom line-ups, that would include design elements of the standard Cabinet Module range where advantageous.

- **SINAMICS S120 Liquid Cooled line-ups**  
For adverse environments SINAMICS S120 Cabinet Modules can also be supplied in a liquid cooled version. The heat loss of the units is transferred to the cooling liquid and dissipated remotely, eliminating the need for air conditioning of an electrical room. Such line-ups include liquid-cooled Line and Motor Modules in the chassis format, combined with a cooling unit appropriately designed for the specific conditions.

#### Empty Cabinet Modules

Siemens customers and partners may wish to combine the advantages of pre-designed, system tested high power standard Cabinet Modules with custom automation or control equipment of their own design, integrated into one single line-up. Siemens can provide empty Cabinet Modules for this purpose:

- **Empty Cabinet Modules**  
Empty Cabinet Modules (without DC bus) would be located at one end of a line-up. These could be fitted with the auxiliary power distribution system used in the rest of the line up, or a back panel, if required.
- **Empty Cabinet Modules with DC bus.**  
If a Cabinet Module is located in the middle of a line-up it would require the DC bus to run through it. The bus could be shrouded to isolate the interior of the cabinet from the power circuits. Alternatively, if additional equipment is to be connected to the common DC bus, Siemens can provide a fused DC feed. This is strongly recommended to ensure the integrity and short circuit protection of the complete system.



In short, the possibilities of the SINAMICS S120 Cabinet Modules are endless. Please contact your local Siemens sales office to discuss your specific needs or obtain an offer.

## Integration Engineering

### Overview

SINAMICS S120 Cabinet Modules are all specified individually, based on an order number and associated option codes. Drawings and documentation (outline dimension and layout drawing, schematic, spare parts list) are provided for each individual Cabinet Module.

With option Y11 Cabinet Modules are grouped into transport sections. This is only a mechanical connection, the drawings are not affected.

As a default there is however no documentation for the complete line-up showing interconnections between Cabinet Modules. The reason is that the factory cannot deduce how the various cabinet modules are intended to function, based on the individual part no.'s. For example, there may be a number of Motor Modules with only some including a control unit, which could be connected in many different ways. One control unit could be used to control a number of power modules, each for a different motor or some power modules could be intended for parallel connection. And there is no way to tell which control unit is to be connected to which power module(s).

"Integration Engineering" to integrate the individual cabinet modules into one functioning line-up can be provided, based on a detailed customer specification.

The scope of delivery of the integration engineering is as follows:

- Checking the combinations and options ordered, in relation to the device configurations.
- Defining how the individual drive objects are to be connected, coordinated with the customer as necessary.
- Checking the performance of the ordered CompactFlash card.
- Installing the required DRIVE-CLiQ cables within the transport sections. Cables between the transport sections are connected at one end.
- Higher-level documentation of the scope of delivery (outline dimension diagram of the line-up, schematics with interconnections, consolidated spare parts list).
- Consolidation of the individual drawings, possibly shipping these to a delivery address different to that of the equipment.
- Customer-specific system and location designations, coordinated with the customer/client.

**Note that in this context "Integration Engineering" is limited only to integrating individual Cabinet Modules into a line-up. This is not to be confused with integration of the drive line-up into the customer's plant and interconnection to external equipment such as power supplies, motors and process control or automation equipment, which is outside the scope of supply of a Cabinet Module line-up!**

### Selection and ordering data

The following standard engineering services can be ordered depending on the number of drives/axes included in an order.

Integration Engineering	Order No.
<b>For 1 drive</b> (also parallel connection) including the associated Line Modules, Sensor Modules, Terminal Modules etc.	<b>6SL3780-0AA00-0AU0</b>
<b>For up to 3 drives</b> (also parallel connection) including the associated Line Modules, Sensor Modules, Terminal Modules etc.	<b>6SL3780-0AC00-0AU0</b>
<b>For up to 5 drives</b> (also parallel connection) including the associated Line Modules, Sensor Modules, Terminal Modules etc.	<b>6SL3780-0AE00-0AU0</b>
<b>For up to 10 drives</b> (also parallel connection) including the associated Line Modules, Sensor Modules, Terminal Modules etc.	<b>6SL3780-0AJ00-0AU0</b>

Engineering services for larger drive systems is also available on request.

### Options

The table below lists the options available for the order specific Integration Engineering (For details see Description of the options):

Available Options	Option code
Customer drawings in dxf format	<b>D02</b>
Advance copy of customer documentation (pdf)	<b>D14</b>
Documentation English/French	<b>D58</b>

When ordering Integration Engineering, the required documentation options should always be ordered together with the Integration Engineering (not to the individual Cabinet Modules).

Specifying the documentation options for individual Cabinet Modules is only required if equipment is ordered without Integration Engineering.

### Description of options

#### Standard documentation

- Customer drawings supplied with SINAMICS S120 Cabinet Modules are provided for each cabinet individually (unless Integration Engineering is ordered to provide system drawings) and are always job specific (showing the configuration actually supplied, options not provided are not shown).
- All customer documentation is provided in electronic format on a CD, which ships inside the drive. All documents are in pdf format (Adobe Acrobat) and are supplied in English with a copy in Spanish (English/Spanish are the default languages for NEMA version Cabinet Modules with order number ending in "U3". English/French is alternatively available by specifying option **D58**). In addition, a paper copy of the Safety and Transportation Guidelines and the Installation Check List are included too.

#### D02

##### Customer drawings in dxf format

Schematics, outline dimension and layout drawings will be provided in AutoCAD (dxf) on the CD (or as specified by other option codes).

#### D14

##### Advance copy of customer documentation (pdf)

To receive a copy of customer drawings earlier than with drive shipment, i.e. after order placement (typically within 2 weeks). If option code D02 is specified, the advance copy of the drawings will be supplied in dxf format too.

#### D58

##### Documentation English/French

Two copies of the documentation (drawings and manuals) will be provided on the CD (or as specified by other option codes), one in English and the other in French.

#### F03, F71, F75, F77, F97

##### Witnessed (or observed) testing

Order code	Description	
F03	Visual inspection by customer	The scope of the inspection comprises: <ul style="list-style-type: none"> <li>• Checking the enclosure type</li> <li>• Checking the equipment (components)</li> <li>• Checking the equipment identifiers</li> <li>• Checking the clearance and creepage distances</li> <li>• Checking the wires</li> <li>• Checking the customer documentation</li> <li>• Submitting the acceptance report</li> <li>• The checks are carried out with the drive deenergized</li> </ul>
F71	Witnessed function test of drive without motor	The scope of the witnessed test comprises: <ul style="list-style-type: none"> <li>• Visual inspection as per option F03</li> <li>• Check of power supply</li> <li>• Check of protective and monitoring devices (simulation)</li> <li>• Check of fans</li> <li>• Precharging test</li> <li>• Functional test without connected motor</li> <li>• Submitting the acceptance report</li> </ul> After the visual inspection with the drive switched off, the drive is connected to rated voltage. No current flows at the drive output.
F77	Witnessed test incl. high-voltage and insulation test	The scope of the acceptance comprises: <ul style="list-style-type: none"> <li>• High-voltage test</li> <li>• Measurement of insulation resistance</li> </ul>
F97	Witnessed customer specific drive acceptance inspections/ tests (on request)	If additional witnessed testing is desired over and above options <b>F03</b> or <b>F71</b> , please provide a specification/ test plan for the factory to submit a quotation.

## Description of Options

### Description of options

#### G20

##### CBC10 Communication Board CANopen

The CBC10 communication board is used to interface the CU320-2 Control Unit of a SINAMICS S120 Cabinet Module to the CAN (Controller Area Network) protocol. The board's driver software fulfills the standards of the following CANopen specification of the CiA organization (CAN in Automation):

- Communication profiles in accordance with DS 301
- Drive profile in accordance with DSP 402 (in this case Profile Velocity Mode)
- EDS (Electronic Data Sheet) in accordance with DSP 306
- Operating status signaling in accordance with DSP 305

The CBC10 Communication Board plugs into the option slot on the CU320-2 Control Unit. The CAN interface on the CBC10 has 2 SUB-D connections for input and output.

The CBC10 Communication Board can only be ordered in conjunction with a CU320-2 Control Unit (option K90 or K95). Note the CU320-2 has only one options slot for one communications or I/O module.

#### G33

##### CBE20 Communication Board Ethernet

The CBE20 communication board connects the CU320-2 DP or CU320-2 PN Control Unit of a SINAMICS S120 Cabinet Module to an additional communications bus. The CBE20 can be parameterized to connect to either:

- **SINAMICS Link** high speed peer-to-peer communications with other CBE20 modules plugged into the CU320-2 control units of other SINAMICS drives, up to 64 nodes.
- **PROFINET** I/O network, 100 Mbit/s full-duplex, supports real-time classes RT (Real-Time) and IRT (Isochronous Real-Time). (Only one communication interface can be used in isochronous operation when operating the CBE20 in a CU320-2 DP or PN Control Unit).
- **EtherNet/IP** (EtherNet Industrial Protocol) is an open standard predominantly used in the automation industry. EtherNet/IP is supported by the Open DeviceNet Vendor Association (ODVA).

In addition, the CBE allows on a PROFINET or EtherNet/IP network:

- Standard **Ethernet TCP/IP** communication for engineering processes using the STARTER commissioning tool

The CBE20 Communication Board plugs into the option slot on the CU320-2 Control Unit. It has 4x RJ45 Ethernet ports.

[Description of the CBE20 Communication Board Ethernet](#) → Chapter 6.

#### G51 to G54

##### TM150 RTD Monitoring Module(s)

Up to four TM150 may be mounted in a Line Connection Module: G51 = qty. 1x TM150, G52 = qty. 2x TM150, G53 = qty. 3x TM150, G54 = qty. 4x TM150.

The TM150 RTD module is suitable for monitoring temperature sensors type Pt100 or Pt1000 (Platinum RTD 100 ohm or 1,000 ohm), KTY84, PTC thermistor or a temperature switch contact (NC). Up to 12 sensors in 2-wire connection or up to 6 sensors in 3- or 4-wire connection can be connected to one TM150.

Temperature values from the TM150 are available for further processing and for transmission to the process control system via bus communications.

Note: TM150 inputs are not electrically isolated. Only temperature sensors isolated per IEC 61800-5-1 may be connected to terminals "+Temp" and "-Temp". Failure to observe these instructions can result in electric shock!

#### G56

##### Monitoring of precharge function

This option provides for the drive controller to monitor the precharge function of Line Modules, as well as on Motor Modules in combination with option L37 (DC disconnect with precharge). If precharge is not completed in a preset time the precharge circuit is opened and a fault is signalled.

#### K01 to K05

##### Safety license for 1 to 5 axes

Safety Integrated Basic Functions (STO, SS1, SBA) do not require a license. A license is, however, required for each axis using Safety Integrated Extended Functions. It is irrelevant which safety functions are used and how many.

Option **K01** includes the license for 1 axis, **K02** for 2 axes, etc. up to option **K05** for 5 axes.

The safety licenses can be optionally ordered retrospectively and loaded to the CompactFlash card. A license key can be generated via the WEB License Manager at:

[www.siemens.com/automation/license](http://www.siemens.com/automation/license)

#### K08

##### AOP30 Advanced Operator Panel, door mounted

The AOP30 Advanced Operator Panel is an optional door mounted local user interface for a Cabinet Module. The AOP30 connects to a CU320-2 control unit via a serial link (RS232). Only one AOP30 can be connected to one CU320-2.

[Description of the AOP30 Advanced Operator Panel](#) → Chapter 6.

#### K46

##### SMC10 Sensor Module Cabinet-Mounted

The SMC10 Sensor Module Cabinet-Mounted connects to a resolver to simultaneously sense the speed and the rotor position angle of a motor, and make this information available to the regulator via the DRIVE-CLiQ interface.

The following encoder signals can be evaluated:

- 2-pole resolver
- Multi-pole resolver

The motor temperature can also be detected using KTY84-130 or PTC thermistors.

[Description of the SMC10 Sensor Module Cabinet-Mounted](#) → Chapter 6.



### Description of options

#### K48

##### SMC20 Sensor Module Cabinet-Mounted

The SMC20 Sensor Module Cabinet-Mounted connects to an incremental encoder to simultaneously sense the speed and the rotor position angle of a motor, and make this information available to the regulator via the DRIVE-CLiQ interface.

The following encoder signals can be evaluated:

- Incremental encoder sin/cos 1 V<sub>pp</sub>
- EnDat absolute encoder
- SSI encoder with incremental signals sin/cos 1 V<sub>pp</sub> (firmware version 2.4 and later)

The motor temperature can also be detected using KTY84-130 or PTC thermistors.

[Description of the SMC20 Sensor Module Cabinet-Mounted → Chapter 6.](#)

#### K50

##### SMC30 Sensor Module for speed feedback

The SMC30 sensor module is used to connect a speed feedback incremental encoder to the drive, and provide the actual speed signal to the regulator via the DRIVE-CLiQ interface.

The following encoder signals can be evaluated:

- Incremental encoders TTL/HTL with/without open-circuit detection (open-circuit detection is only available with bipolar signals)
- SSI encoder with TTL/HTL incremental signals
- SSI encoder without incremental signals

The motor temperature can also be detected using a KTY84-130 sensor or PTC thermistors.

[Description of the SMC30 Sensor Module Cabinet-Mounted Panel → Chapter 6.](#)

#### K51

##### VSM10 Voltage Sensing Module

The VSM10 Voltage Sensing Module reads the voltage waveform at the drive output. This provides the flying restart function when the SINAMICS S120 drive is connected to a permanent magnet synchronous machine without encoder.

[Description of the VSM10 Voltage Sensing Module → Chapter 6.](#)

#### K52

##### Additional SMC30 Sensor Module

This option code is to add a second SMC30 sensor module (in addition to one specified by option K50). Two SMC30 with associated encoders are required for Safety Extended functions.

#### K70

##### Auxiliary AC voltage supply in the Line Connection Module

Cabinet Modules require auxiliary and control power supplies. The current demand for the various auxiliary voltages must be determined when configuring the line-up and can be supplied either from external sources, or from an Auxiliary Power Supply Module.

Alternatively, for smaller line-ups option K70 provides only the line voltage auxiliary supply in the Line Connection Module to power mostly fans (230 V AC and 24 V DC will need to be provided from external sources). This arrangement allows the control system to operate independently even if the main power source for the line-up is disconnected).

Option K70, provides the following auxiliary supplies:

- Line voltage 380 V to 480 V or 500 V to 600 (690) V 1 phase AC (approx. 80 A)

The auxiliary AC voltage supplies in the Line Connection Module connect to the auxiliary power supply system, from where they are distributed to the rest of the line-up.

#### K76

##### Auxiliary AC & DC voltage supplies in the Line Connection Module

Similar to option K70 above, option K76 provides both AC and DC auxiliary supplies in the Line Connection Module, as follows:

- Line voltage 380 V to 480 V or 500 V to 600 (690) V 1 phase AC (approx. 80 A)
- 230 V 1 phase AC (Line Connection Modules < 800 A: approx. 4 A, > 800 A: approx. 6 A)
- 24 V DC (Line Connection Modules < 800 A: approx. 20 A, > 800 A: approx. 40 A)

The auxiliary voltage supplies in the Line Connection Module connect to the auxiliary power supply system, from where they are distributed to the rest of the line-up.

#### K82

##### Terminal interface for controlling the "Safe Torque Off" and "Safe Stop 1" safety functions

This terminal interface offers a wide voltage range (24 V to 240 V DC or AC) for easy integration of the following Safety Integrated basic functions into the plant controls (terminology as defined in draft IEC 61800-5-2):

- Safe Torque Off (STO)
- Safe Stop 1 (SS1) (time-controlled)

The integrated safety functions, starting from the Safety Integrated (SI) input terminals of the components (Control Unit and Motor Module), satisfy the requirements of IEC 61800-5-2, IEC 60204-1, ISO 13849-1 Category 3 (previously EN 954-1) for Performance Level (PL) d and IEC 61508 SIL 2.

With option K82, the requirements specified in IEC 61800-5-2, IEC 60204-1, ISO 13849-1 Category 3 (previously EN 954-1) for Performance Level (PL) d and IEC 61508 SIL 2 are fulfilled.

The Safety Integrated functions using option K82 are only available in conjunction with certified components and software versions.

These Safety Integrated functions of SINAMICS are generally certified by independent institutes. An up-to-date list of certified components is available on request from your local Siemens office.

## Description of Options

### Description of options

#### K87

##### TM54F Terminal Module

The TM54F Terminal Module provides fail safe digital inputs and outputs for hardwired control of the Safety Integrated extended functions (as opposed to control via bus communications with PROFIsafe).

The TM54F must be connected directly to a Control Unit via DRIVE-CLiQ. Each Control Unit is uniquely assigned to one TM54F.

Note: It is not permissible to connect Motor Modules or Line Modules to a TM54F.

The TM54F has 4 fail safe digital outputs and 10 fail safe digital inputs. A fail-safe digital output consists of one 24 V DC switching output, an output switching to ground and one digital input to check the switching state. A fail-safe digital input consists of two digital inputs.

#### K88

##### Safe Brake Adapter SBA, 230 V AC

Safe Brake Control (SBC) is a basic safety function that is used in safety-relevant applications, for example in presses or rolling mills. In the no-current state, the brake is applied to the drive motor shaft using spring force. The brake is released when current flows in it (low active).

The Safe Brake Adapter 230 V AC is factory installed in the Cabinet Module. A source of power is connected to terminal -X12 on the Safe Brake Adapter. For control, a connection is established between the Safe Brake Adapter and the Control Interface Module in the factory using a wire harness.

On the plant side, to control the brake, a connection must be made between terminal -X14 on the Safe Brake Adapter and the brake.

**Note: The safe brake adapter is not yet UL listed. Option K88 cannot be included in a UL listed line-up.**

#### K90

##### CU320-2 DP (PROFIBUS) Control Unit

Option K90 assigns a CU320-2 DP Control Unit to a Line Module or Motor Module. This control unit handles the communications, regulator and control functions. DRIVE-CLiQ is used to connect the CU320-2 to power modules and, if applicable, to additional I/O and sensor modules. The CU320-2 includes a PROFIBUS interface as standard for higher level bus communications.

The full performance of the CU320-2 is only available on systems with performance expansion (option K94).

Description of the CU320-2 Control Unit → Chapter 6.

#### K94

##### Performance expansion for CU320-2 Control Unit

Options K90 and K95 include standard SINAMICS S120 firmware (without performance expansion) suitable for controlling up to 3 axes. The performance required from the CU320-2 DP Control Unit can be calculated using SIZER and is based on the number of connected Motor or Line Modules and system components, as well as the dynamic performance demanded.

With option K94, the CU320-2 Control Unit is provided with a CompactFlash card with performance expansion, which enables the full performance capabilities of the CU320-2 Control Unit to be utilized (control of up to 6 axes).

In addition to the firmware, the CompactFlash card also contains licensing codes that are required to enable firmware options, such as performance expansion and the Safety Integrated Extended functions. (Additional licenses are required to utilize Safety Integrated extended functions, refer to option K01 to K05 above).

#### K95

##### CU320-2 PN (PROFINET) Control Unit

Option K95 assigns a CU320-2 PN Control Unit to a Line Module or Motor Module. This control unit handles the communications, regulator and control functions. DRIVE-CLiQ is used to connect the CU320-2 to power modules and, if applicable, to additional I/O and sensor modules. The CU320-2 includes a PROFINET interface as standard for higher level bus communications.

The full performance of the CU320-2 is only available on systems with performance expansion (option K94).

Description of the CU320-2 Control Unit → Chapter 6.

#### L07

##### dV/dt filter compact plus Voltage Peak Limiter

The dV/dt filter compact plus VPL (Voltage Peak Limiter) limits the voltage rate-of-rise dV/dt to values < 1600 V/μs, and the typical voltage peaks to the following values per the limit value curve A of IEC 60034-25, 2007:

- < 1150 V at  $U_{Line} < 575 V$
- < 1400 V at  $660 V < U_{Line} < 690 V$

**Note that these dV/dt and peak voltage values exceed the allowable values for motors insulated to NEMA MG1 part 30.** (The dV/dt filter compact plus VPL may be used with suitably insulated IEC motors. For motors insulated to NEMA MG1 part 30, the dV/dt filter plus VPL (option L10) should to be selected).

The dV/dt filter compact plus VPL is designed for the following maximum motor cable lengths:

- Shielded cables: 328 ft [100 m]
- Unshielded cables: 492 ft [150 m]

For motor cables exceeding these lengths, the dV/dt filter plus VPL (option L10) needs to be selected.

**Note:** Operation with output frequencies < 10 Hz is permissible for max. 5 minutes.

Also refer to the appropriate notes in the SINAMICS Low Voltage Engineering Manual.

Note: Option L07 cannot be combined with the following options:

- L08 (motor reactor)
- L10 (dV/dt filter plus VPL).

### Description of options

#### L08

##### Motor reactor

Motor reactors reduce the voltage load on the motor windings by reducing the voltage gradients on the motor terminals generated by the drive. At the same time, the capacitive charge/discharge currents that place an additional load at the Motors Module output when long motor cables are used are reduced.

Suitably dimensioned motor reactors or connecting several motor reactors in series offers the possibility of dealing with larger cable capacitances, therefore allowing longer motor cable length to be connected.

In the case of multi motor drives, the use of motor reactors is recommended as a general principle.

The motor reactor is accommodated in the Cabinet Module. A supplementary cabinet 23.6 inch [600 mm] wide located to the right of the Motor Module is only required for the chassis format in frame sizes HX and JX.

Note: The terminal lugs of the reactors are not nickel-plated.

For Motor Modules in the chassis format, the maximum motor cable length with or without motor reactors is 980 ft [300 m] (shielded) or 1,480 ft [450 m] (unshielded). Please consult factory if longer motor cable lengths are required.

For Motor Modules in the Booksize Cabinet Kit format with motor reactors (option L08), the maximum motor cable lengths as specified in the table below can be reached:

#### L09

##### Two motor reactors in series

For Single Motor Modules in the Booksize Cabinet Kit format, selecting option L09 provides two motor reactors in series, which are accommodated within the standard width of the Cabinet Kit.

The maximum permissible motor cable lengths with option L09 are specified in the table below.

Note: The terminal lugs of the reactors are not nickel-plated.

Booksize Cabinet Kit	Rated output current of motor module	Maximum motor cable length for Booksize Cabinet Kit Motor Modules with output reactors					
		Shielded cable			Unshielded cable		
		Without reactor	With one reactor (option L08)	With two reactors in series (option L09)	Without reactor	With one reactor (option L08)	With two reactors in series (option L09)
Order No.	[A]	ft [m]	ft [m]	ft [m]	ft [m]	ft [m]	ft [m]
6SL3720-1TE21-0AB3	9	164 [50]	443 [135]	—	246 [75]	6156 [200]	—
6SL3720-1TE21-8AB3	18	230 [70]	525 [160]	1,050 [320]	246 [75]	787 [240]	1,575 [480]
6SL3720-1TE23-0AB3	30	328 [100]	623 [190]	1,230 [375]	492 [150]	919 [280]	1,837 [560]
6SL3720-1TE24-5AB3	45	328 [100]	656 [200]	1,312 [400]	492 [150]	984 [300]	1,968 [600]
6SL3720-1TE26-0AB3	60	328 [100]	656 [200]	1,312 [400]	492 [150]	984 [300]	1,968 [600]
6SL3720-1TE28-5AB3	85	328 [100]	656 [200]	1,312 [400]	492 [150]	984 [300]	1,968 [600]
6SL3720-1TE31-3AB3	132	328 [100]	656 [200]	1,312 [400]	492 [150]	984 [300]	1,968 [600]

## Description of Options

### Description of options

#### L10

##### *dV/dt filter with VPL (Voltage Peak Limiter)*

The dV/dt filter plus VPL (Voltage Peak Limiter) limits the voltage rate-of-rise dV/dt to values < 500 V/μs, and the typical voltage peaks to the following values according to the limit value curve to IEC/TS 60034-17: 2006:

- < 1000 V at  $U_{Line} < 575$  V
- < 1250 V at  $660$  V <  $U_{Line} < 690$  V

The dv/dt filter plus VPL functionally comprises two components, the dv/dt reactor and the voltage limiting network VPL, which cuts off voltage peaks and feeds back the energy into the DC bus. Option L10 is installed in an additional cabinet with a width of 23.6 inch [600 mm] that is located on the right-hand side of the Motor Module.

A dv/dt filter plus VPL generally allows the use of standard non-inverter duty motors with standard insulation and without insulated bearings for VFD operation.

For motors insulated per NEMA MG1, part 30 (voltage peaks <1,000 V and dV/dt <500 V/μs) the maximum allowable motor cable length is as follows. With longer cable lengths voltage peaks may exceed 1,000 V.

Rated voltage	Maximum motor cable length for motors insulated per NEMA MG1, part 30	
	Unshielded cable	Shielded cable
380 – 480 V	980' (300 m)	980' (300 m)
500 – 600 V	490' (150 m)	490' (150 m)

The dV/dt filter plus VPL is designed for the following maximum motor cable lengths:

- Shielded cables: 980 ft [300 m]
- Unshielded cables 1,480 ft [450 m]

When using dv/dt filters, restrictions regarding permissible pulse and output frequencies must be observed.

Please refer to the appropriate notes in the [SINAMICS Low Voltage Engineering Manual](#).

Note: Parts of option **L10** do not have nickel-plated copper busbars.

Option L10 cannot be combined with the following options:

- **L07** (dv/dt filter compact plus VPL)
- **L08** (motor reactor).

#### L13

##### *Input contactor*

Line Connection Modules up to 800A rated input current include a manually operated molded case circuit breaker (MCCB) disconnect. The input contactor allows the drive to be connected to or be disconnected from the input power supply in response to an electrical control signal. This function is also required to disconnect the line-up from the supply in the event of an Emergency OFF (in this case it is controlled by the drive regulator).

An input contactor option **L13** is available for Line Connection Modules with Basic Line Modules (option L43); for Smart Line Modules and Active Line Modules, the contactor is already included for the purpose of pre-charging.

#### L21

##### *Line side surge arrestors for ungrounded supply systems*

Three single phase surge arrestors are connected ahead of the incoming circuit breaker disconnect.

#### L22

##### *Without input line reactor*

Basic Line Modules or Smart Line Modules are supplied as standard with line reactors; the reason for this is that a line reactor primarily assures the minimum current form factor, protects the drive against excessive harmonic currents and thus overloads, and improves the sensitivity of the VFD to voltage spikes. An input line reactor is recommended for most installations.

If the drive is powered via a separate drive isolation transformer, or if the ratio between the line short circuit capacity at the point of connection and the rated drive output is low (high network impedance), the input line reactor may be omitted by selecting option **L22**.

Option L22 is available for Line Connection Modules (rated current < 2000 A) in conjunction with Basic Line Modules (option L43), as well as for Smart Line Modules.

This option is not available for Basic or Smart Line Modules connected in parallel to a single Line Connection Module as line reactors are required to ensure current sharing.

For additional information, please refer to the [SINAMICS Low Voltage Engineering Manual](#).

#### L25

##### *Drawout circuit breaker*

Line Connection Modules with an input current of > 800 A are equipped with a fixed mounted insulated case circuit breakers as standard. If the customer requires a visible isolating distance, a drawout circuit breaker can be ordered as an option.

### Description of options

#### L34

##### Output circuit breaker

A circuit breaker is provided at the output of Motor Modules chassis format, to disconnect the motor from the drive.

A permanent-magnet synchronous motor generates a voltage at its motor terminals proportional to the speed, and in the event of an overspeed a very high voltage can be applied to the output of the motor module which can damage to the inverter as well as the DC bus and other components connected to it.

The output circuit breaker option L34 is available to disconnect the motor in the event of a fault or if maintenance work is to be carried out. Option L34 is completely prewired and is accommodated in an additional cabinet, which is arranged to the right hand side of the Motor Module (16 " [400 mm] wide for frame sizes FX/GX, 23.6" [600 mm] wide for frame size HX/JX).

The circuit breaker is automatically controlled by the Motor Module. A TM31 Terminal Module is included with this option to provide the associated inputs and outputs.

Option **L34** cannot be combined with option **L10** (dv/dt filter plus Voltage Peak Limiter).

#### L37

##### DC disconnect including precharge circuit

If, for reasons relating to the process or availability, the Motor Module needs to be disconnected from or connected to the live DC bus during operation, a manually operated disconnect switch can be ordered as Option L37. For Motor Modules in the chassis format, this takes the form of a mechanically operated disconnect switch, and for Booksize Cabinet Kits an electrically operated contactor combination.

Option L37 is installed on the busbar between the Motor Module and the main DC bus. To ensure that the motor module can be connected to a live DC bus, the option also includes a precharge circuit for the DC capacitors of the relevant Motor Module.

The switching operation is performed externally. The operating levers are padlockable (padlock not included in scope of delivery).

Option L37 also includes option M60 (additional touch protection) for channeling the cooling air.

Options L61/L62 and L64/L65 (braking units) cannot be ordered together with option L37 for space reasons.

**Note: Option L37 is not yet UL listed and cannot be included in a UL listed line-up.**

#### L41

##### Current transformer upstream of main circuit breaker

If additional current transformers are required for measuring or monitoring purposes, these can be ordered as option L41 for the Line Connection Modules. The current transformers are installed upstream of the main circuit breaker in all three infeed phases.

The transformers have an accuracy class of 1.0. The secondary current is 5 A, maximum in a NEMA version Line Connection Module (order number ending in **U3**).

The transformer measuring connections are routed to the terminal block in the Line Connection Module.

Comment: These current transformers are already included in options P10 and P11 (power meter).

#### L42

##### Line Connection Module for Active Line Module

Option L42 adds the relevant components (precharge connection, busbars etc.) in the Line Connection Module for connection to an Active Line Module. Also refer to the descriptions in section 3.

#### L43

##### Line Connection Module for Basic Line Module

Option L43 adds the relevant components (line reactor, precharge connection, busbars etc.) in the Line Connection Module for connection to a Basic Line Module. Also refer to the descriptions in section 3.

#### L44

##### Line Connection Module for Smart Line Module

Option L44 adds the relevant components (precharge connection, busbars etc.) in the Line Connection Module for connection to a Smart Line Module. Also refer to the descriptions in section 3.

#### L45

##### EMERGENCY OFF pushbutton, installed in the cabinet door

The twist-to-release, padlockable EMERGENCY OFF pushbutton is door mounted in the Line Connection Module, with its contacts wired to a terminal block. This option is provided for integration into the customer's external EMERGENCY OFF circuit.

**NOTE: This option is for a pushbutton only, it is not wired into the drive circuit.**

#### L55

##### Enclosure space heater

Space heaters are recommended at low ambient temperatures and high levels of humidity to prevent condensation. One 100 W heater is provided for each Cabinet Module <32" (800 mm) wide. For cabinets exceeding this width, two heaters will be installed. This option requires an external power source (110 to 230 V 1 phase AC, fused for max. 16 A).

Option L55 cannot be combined with option K82 (Terminal interface for controlling safety functions).

#### L61, L62, L64, L65

##### Braking units

Braking units may be required for drives in which motors might operate in generator mode and the excess energy cannot be absorbed by other loads or regenerated back into the supply system, or braking is required if the supply system fails.

The braking unit comprises two components:

- A Braking Module that can be installed in the air discharge of chassis format power units
- A braking resistor to be mounted externally (IP20 degree of protection).

The braking unit functions as an autonomous unit, and does not require an external power supply. During the braking process, the kinetic energy is converted into heat in the externally mounted braking resistor.

## Description of Options

### Description of options

A cable length of max. 328 ft. (100 m) is permissible between the Braking Module and the braking resistor. This allows the braking resistor to be mounted externally so that heat losses can be dissipated outside the drive enclosure. The braking resistor is directly connected to the Braking Module.

For SINAMICS S120 Cabinet Modules the following braking modules are available, depending on the frame size:

Option	For frame size	Braking Module		
		Rated power $P_{DB}$ kW	Rated power $P_{DB}$ kW	Rated power $P_{DB}$ kW
380 ... 480 V 3ph. AC (& 660... 690 V 3ph. AC)				
L61	FX	25	100	125
L62	GX, HX, JX	50	200	250
500 ... 600 V 3ph. AC				
L64	FX	25	100	125
L65	GX, HX, JX	50	200	250

$P_{DB}$ : Rated power (continuous braking power)

$P_{20}$ : 20 s power referred to a braking interval of 90 s

$P_{15}$ : 15 s power referred to a braking interval of 90 s

Note: Braking Module options cannot be combined with the DC disconnect (option L37).

For additional information, please refer to the description of Braking Modules in Section 4.

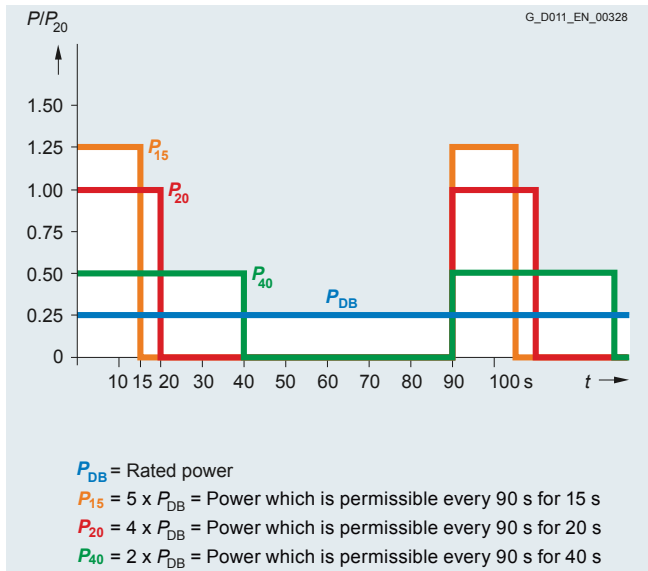

Load diagram for Braking Modules and braking resistors

Additional notes about possible duty cycles of the braking resistors and other engineering notes are included in the SINAMICS Low Voltage Engineering Manual.

### L70

#### High SCCR rating

Line Connection Modules have a short circuit current rating (SCCR) per UL508A supplement SB as shown in section 3. For Line Connection Modules rated 1,000 A and up, a high SCCR (84 or 100 kA) is optionally available by specifying option code L70.

### L87

#### Insulation Monitor for ungrounded supplies

An insulation monitor must be used if the drive is operated on an ungrounded power supply. This device monitors the complete electrically connected circuit for insulation (ground) faults. Two threshold values of resistance to ground (between 1 k $\Omega$  and 10 M $\Omega$  can be set (for alarm and fault).

Note: Only one insulation monitor can be used in an electrically connected network.

Since the response philosophy to a ground fault may differ, output relay contacts are not wired in the drive but are available for wiring to drive terminals or integration into a plant control system. Additional terminals on the device are provided for an output to an external display, and inputs for external reset and test buttons.

### M06

#### Base (plinth) 4" (100mm) high

The 4" enclosure base allows larger bending radii for cables (cable entry from below) and routing them within the base. It is delivered already mounted to the enclosure. The height of the operator panel changes accordingly.

The base is always colored RAL 7022 (umbra grey). A special color is not possible.



Enclosure with option M06

### M07

#### Base (plinth) 8" (200mm) high

The 8" enclosure base provides more space for bending and routing cables. The base is delivered already mounted to the enclosure. The height of the operator panel changes accordingly.

The base color is the same as the enclosure, RAL 7035 (light grey). If the enclosure is ordered in a special color (option Y09), the 8" base is also painted the same color.

### M21

#### Enclosure NEMA 1 (IP 21)

In the base IP20 enclosure air is exhausted upwards through the top of the cabinet, which is covered by a metal grate. With option M21 a raised roof is added to the cabinet, to provide protection against falling dirt. The enclosure height increases by approx. 10" (250 mm).

For transport reasons the raised roof and standoffs are shipped as loose items and must be mounted on site.

### Description of options

#### M23

##### Enclosure NEMA 1 filtered (IP23)

A tophat is added to the enclosure increasing its height by approx. 16" (400 mm). Louvers and foam air filters are added to air inlet and outlet openings. Option M23 also includes option M60 (additional covers for touch safety).

A NEMA 1 filtered (IP23) enclosure is the minimum required for listing the enclosed drive per UL508A. For transport reasons the tophat is shipped as a loose item and must be mounted on site.

Note the tophat will be supplied in the same color as the specified for the enclosure. However, the molded plastic louvers are colored RAL7035 and cannot be painted.

#### M26

##### Side panel mounted on right

Cabinet Modules (respectively transport sections) are open at both sides, for side-by-side installation with other cabinet modules. With option M26, the cabinet is fitted with a side panel (skin) on the right (when viewed from the front).

Note: Side panels on both sides of the line-up are necessary to obtain the enclosure type/degree of protection specified.

#### M27

##### Side panel mounted on left

Cabinet Modules (respectively transport sections) are open at both sides, for side-by-side installation with other cabinet modules. With option M27, the cabinet is fitted with a side panel (skin) on the left (when viewed from the front).

Note: Side panels on both sides of the line-up are necessary to obtain the enclosure type/degree of protection specified.

#### M43

##### Enclosure IP43

Similar to NEMA 1 filtered (M23) with tophat and foam air filters on air inlets and outlets, but additionally a 1mm wire mesh is provided behind the air filters.

The tophat increases the base enclosure height by approx. 16" (400 mm).

Note the tophat will be supplied in the same color as the specified for the enclosure. However, the molded plastic louvers are colored RAL7035 and cannot be painted.

#### M54

##### Enclosure NEMA 12 ventilated (IP54)

Similar to NEMA 1 filtered (M23) with tophat and louvers but with fine paper air filters added to air inlet and outlet openings, to prevent even fine dust particles from entering the enclosure in very dusty environments.

These fine dust filters are a patented design for high volume airflow with small derating. Please refer to Engineering Information section 6 for current derating with a NEMA 12 filtered enclosure.

The tophat increases the base enclosure height by approx. 16" (400 mm).

Note the tophat will be supplied in the same color as the specified for the enclosure. However, the molded plastic louvers are colored RAL7035 and cannot be painted.

#### M59

##### Closed cabinet doors, air inlet from below through floor

If the Cabinet Modules are installed on a false floor or duct which forms part of a forced ventilation system, the modules can be ordered with closed doors (without ventilation openings). To ensure an adequate air inlet cross-section, the units are shipped without the standard base plates. In this case, the customer must ensure that dirt, dust or moisture cannot enter the Cabinet Module. Cables must be routed in such a way that they do not impede the flow of air through the cabinet floor opening.

Suitable touch protection must be provided if the area beneath the Cabinet Modules can be accessed.

#### M60

##### Additional touch protection

With option M60, additional covers are installed for improved touch protection of live parts, such as in the area of the AC and DC busbars and in front of the power unit.

Option M60 is already included with Options M23, M43 and M54.

#### M70

##### EMC shield bus

The EMC shield bus is used for the connection of the shields of cables on the line and motor sides. The supplied EMC shield clamps provide a large surface area for the connection, to ensure effective grounding also of high frequency noise.

#### M80 to M87

##### DC busbar system

The busbars for the common DC bus are located in the upper section of the Cabinet Modules, and connect the Line Modules to the Motor Modules. They are nickel plated as standard and are available in different sizes for a range of current carrying capacities.

The common DC bus is dimensioned according to the load requirements and demand factor associated with operation of the individual drives, and according to the specific Cabinet Module layout. For this reason the DC bus is not supplied as standard, but must be specified as an option for each Cabinet Module. [Please also refer to section 2 – System configuration guidelines.](#)

When selecting the DC bus, it is important to ensure that the bus sizes in adjacent Cabinet Modules are compatible with each other (refer to the table below and option selection matrix for the Cabinet Modules in question).

If Cabinet Modules are ordered in factory assembled transport sections with option Y11, all Cabinet Modules in a transport section must have identical busbars.

Note that it is mandatory for all Line Modules, Motor Modules (Chassis format) and Booksize Base Cabinets to include a DC bus option.

## Description of Options

### Description of options

Option	Rated current of DC bus $I_N$ A	Qty. of parallel busbars per pole	Busbar size [width] mm	Compatible with option(s)
M80	1,170	1	60	M83
M81	1,500	1	80	M84 and M86
M82	1,840	1	100	M85 and M87
M83	2,150	2	60	M80
M84	2,730	2	80	M81 and M86
M85	3,320	2	100	M82 and M87
M86	3,720	3	80	M81 and M84
M87	4,480	3	100	M82 and M85

The scope of delivery also includes the jumpers required to link the DC bus of a Cabinet Module to the adjacent one.

#### M90

##### Lifting beam/eye bolts

For single cabinets up to a width of 24" (600 mm), eye bolts are provided. For larger enclosures transportation beams are provided.

Once the drives are in position, the lifting hardware needs to be removed to mount the raised roof or tophats.

When Cabinet Modules are ordered in factory assembled transport sections (option Y11), the transportation beams are automatically included and option M90 does not need to be specified additionally.



SINAMICS drive on pallet with transportation beams

#### P10

##### Power Meter

A power meter (Socomec Diris A40 or equivalent) is mounted in the door of the Line Connection Module. The meter displays measured and calculated values including voltages, currents, power factor, THD, active, reactive and apparent power etc. Current transformers (option L41) are included in option P10.

#### P11

##### Power Meter with PROFIBUS port

A power meter (Sentron PAC3200 or equivalent) is mounted in the door of the Line Connection Module. The meter displays measured and calculated values including voltages, currents, power factor, THD, active, reactive and apparent power etc. Current transformers (option L41) are included in option P10.

The meter includes a PROFIBUS communications port for transmitting data to a control system.

#### T58

##### Nameplate English/French

The standard nameplate text is in both English and Spanish. This option provides for a nameplate with both English and French text.

#### U90

##### UL listing per UL508A

This option needs to be selected for every Cabinet Module in a drive line-up that is to be provided with a UL listing mark per UL508A (when built in the US, UL file number E83449).



UL listing mark

Note that Integration Engineering (see page 5/8) must be ordered for a UL listed line-up.

Please refer to section 2 – UL listing of a SINAMICS S120 Cabinet Module line-up for additional information.

#### U91

##### cUL listing for Canada per UL508A

Similar to option U90, this option needs to be selected for every Cabinet Module in a drive line-up that is to be provided with a cUL listing mark for Canada per UL508A (when built in the US, UL file number E83449).

Note that Integration Engineering (see page 5/8) must be ordered for a UL listed line-up.

Please refer to section 2 – UL listing of a SINAMICS S120 Cabinet Module line-up for additional information.

#### Y09

##### Special enclosure paint color (specify color)

The standard color of the drive enclosures is RAL 7035 (light grey). A special color must be specified in plain text when ordering.

In general, colors available as powder coating can be ordered. Please consult factory to confirm. The enclosure, tophats and, if specified, 8" high plinths (option M07) will be supplied in the specified special color.



### Description of options

**Note:**

1. The molded plastic parts (e.g. louvers) are colored RAL 7035 and cannot be painted.
2. 4" high plinths are always colored RAL 7022 (umber grey).
3. Cabinet frames and interiors are always colored RAL 7035.

**Y11**

**Factory assembly into transport sections (specify sections)**

With this option, Cabinet Modules are factory assembled into transport sections with a maximum total width of up to approx. 8 ft. (2,400 mm). The modules in a section are interconnected, both mechanically and electrically (electrical interconnections include the auxiliary power supply system, and power connections between Line Connection Modules and Line Modules. Control connections are not included – please refer to the section on Integration Engineering).

The DC bus (options M80 to M87) in a transport section is provided as a solid bus for the complete section, to reduce the number a connection points. For this reason the identical bus size must be specified for Cabinet Modules in one section.

Which Cabinet Modules are to be included in a specific transport section, and their sequence from left to right must be specified in plain text according to the syntax below:

Plain text specification:	TE	1	—	1...5
Transport section				
Sequence no. of transport section				
Position of Cabinet Module within transport section				

**Examples:**

- TE1-1 for the 1st cabinet in transport section 1
- TE1-2 for the 2nd cabinet in transport section 1
- TE2-1 for the 1st cabinet in transport section 2

Option Y11 is particularly recommended for units comprising Line Connection Modules and Line Modules because the required power connections, and connections for precharge circuits, for example, are made in the factory.

A transport section is always shipped with a transportation beam (option M90 is not required).

**Y31**

**One line label for system identification, 40 x 80 mm**

Lamicaid labels (white with black lettering) for identifying Cabinet Modules are available. The labels are attached to the cabinet door.

Dimensions H x W: 40 x 80 mm (approx. 1.6" x 3.2")

The text must be specified in plain text when ordering.

Field 1: Max. 9 characters, font size 10 mm (approx. 0.4").

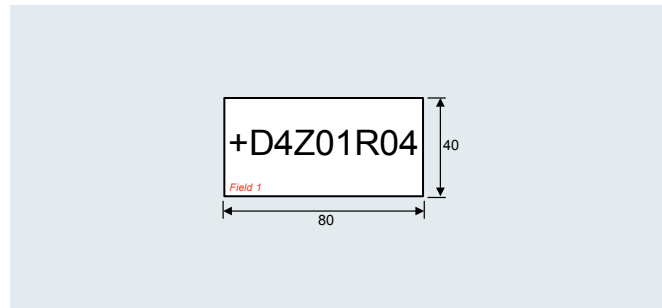

**Y32**

**Two line label for system identification, 40 x 180 mm**

Lamicaid labels (white with black lettering) for identifying Cabinet Modules are available. The labels are attached to the cabinet door.

Dimensions H x W: 40 x 180 mm (approx. 1.6" x 7.1")

The text must be specified in plain text when ordering.

Field 1: Max. 9 characters, font size 10 mm (approx. 0.4").

Field 2: Max. 9 characters, font size 10 mm (approx. 0.4").

Field 3: Max. 20 characters, font size 10 mm (approx. 0.4").

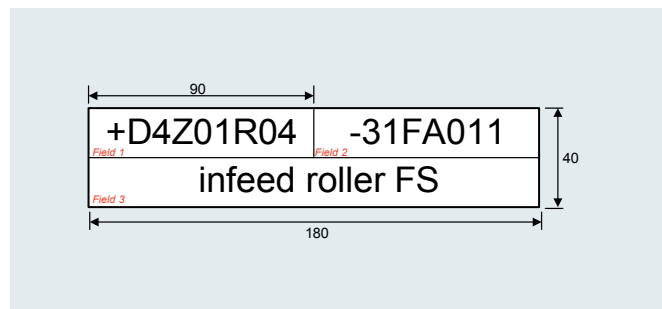

**Y33**

**Four line label for system identification, 40 x 180 mm**

Lamicaid labels (white with black lettering) for identifying Cabinet Modules are available. The labels are attached to the cabinet door.

Dimensions H x W: 40 x 180 mm (approx. 1.6" x 7.1")

The text must be specified in plain text when ordering.

Field 1: Max. 9 characters, font size 10 mm (approx. 0.4").

Field 2: Max. 20 characters, font size 6 mm (approx. 0.25").

Field 3: Max. 20 characters, font size 6 mm (approx. 0.25").

Field 4: Max. 20 characters, font size 6 mm (approx. 0.25").

Field 5: Max. 20 characters, font size 6 mm (approx. 0.25").

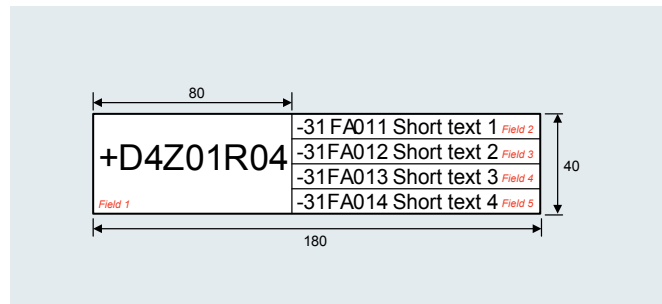

# SINAMICS S120 Cabinet Modules

Notes

5



<b>6/2</b>	<b>Technical data</b> Electrical and mechanical specifications Ambient conditions Mechanical stability Compliance with standards
<b>6/5</b>	<b>Characteristic curves</b> Derating due to altitude and temperature Derating as a function of pulse frequency Overload capability
<b>6/8</b>	<b>Control units and interfaces</b> CU320-2 DP Control Unit CU320-2 PN Control Unit SINAMICS S120 firmware CBE20 Communications board Ethernet BOP20 Basic Operator Panel AOP30 Basic Operator Panel Customer Terminal Block – X55
<b>6/19</b>	<b>Sensor and I/O modules</b> SMC10 Sensor Module SMC20 Sensor Module SMC30 Sensor Module TM150 Terminal (RTD) Module VSM10 Voltage Sensing Module
<b>6/24</b>	<b>Connection system – Signal cables</b> DRIVE-CLIQ cables
<b>6/28</b>	<b>Safety Integrated</b> Safety Integrated Functions TM54F Terminal Module, Fail Safe SBA Safe Brake Adapter

# SINAMICS S120 Cabinet Modules

## Technical data

### Technical data

#### General technical specifications

Electrical specifications	
<b>Line voltages</b>	380 ... 480 V 3 AC, $\pm 10\%$ (-15 % < 1 min) 500 ... 600 (690) V <sup>1)</sup> 3 AC, $\pm 10\%$ (-15 % < 1 min)
<b>Line supply types</b>	Grounded TN/TT systems and non-grounded IT systems
<b>Line frequency</b>	47 ... 63 Hz
<b>Output frequency<sup>2)</sup></b>	
• Control type Servo	0 ... 650 Hz
• Control type Vector	0 ... 600 Hz
• Control type V/Hz	0 ... 600 Hz
<b>Line power factor Fundamental</b>	
• Basic Line Module	> 0.96
• Smart Line Module	> 0.96
• Active Line Module	Adjustable (factory setting = unity power factor)
<b>Efficiency</b>	
• Basic Line Module	> 99.0 %
• Smart Line Module	> 98.5 %
• Active Line Module	> 97.5 % (including Active Interface Module)
• Motor Module	> 98.5 %
<b>Overvoltage category</b>	III to IEC 61800-5-1
<b>Control method</b>	Vector/servo control with and without encoder or V/Hz control
<b>Fixed speeds</b>	15 fixed speeds plus 1 minimum speed, parameterizable (in the default setting, 3 fixed setpoints plus 1 minimum speed are selectable using terminal block/PROFIBUS/PROFINET)
<b>Skipped speed ranges</b>	4, parameterizable
<b>Setpoint resolution</b>	0.001 rpm digital (14 bits + sign) 12 bit analog
<b>Braking operation</b>	With Active Line Modules and Smart Line Modules, four-quadrant operation as standard (energy recovery). With Basic Line Modules, single-quadrant operation as standard. Braking using an optional braking module.
Mechanical specifications	
<b>Enclosure type</b>	Base IP20, optionally NEMA 1 up to NEMA 12 ventilated (IP54)
<b>Protection class</b>	I acc. to IEC 61800-5-1
<b>Touch protection</b>	IEC 50274/BGV A3 for the intended purpose, and per UL508A
<b>Cabinet system</b>	Rittal TS 8, doors with double-barb lock, three-section base plates for cable entry
<b>Paint finish</b>	RAL 7035 (indoor requirements)
<b>Type of cooling</b>	Forced air cooling AF to IEC 60146

1) For UL listing the maximum supply voltage is 600 V AC. However, Cabinet Modules are rated for 690 V AC per IEC standards.

2) Please note:

- The correlation between the maximum output frequency, pulse frequency and current derating. Higher output frequencies for specific configurations are available on request.
- The correlation between the minimum output frequency and permissible output current (current derating).

### Technical data

Ambient conditions	Storage <sup>1)</sup>	Transport <sup>1)</sup>	Operation
<b>Ambient temperature</b>	-13 ... 131 °F (-25 ... +55 °C)	-13 ... 158 °F (-25 ... +70 °C) down to <u>-40 °F (-40 °C)</u> <sup>2)</sup> for 24 hours	32 ... +104 °F (0 ... +40 °C) to +122 °F (+50 °C) see derating data
<b>Relative humidity</b> (condensation not permissible)	<u>5 ... 95%</u> <sup>2)</sup> acc. to IEC 60721-3-1	5 ... 95% at 40 °C Class 2K3 acc. to IEC 60721-3-2	5 ... <u>95%</u> <sup>2)</sup> Class 3K3 acc. to IEC 60721-3-3
<b>Environmental class/harmful chemical substances</b>	Class 1C2 acc. to IEC 60721-3-1	Class 2C2 acc. to IEC 60721-3-2	Class 3C2 acc. to IEC 60721-3-3
<b>Organic/biological influences</b>	Class 1B1 acc. to IEC 60721-3-1	Class 2B1 acc. to IEC 60721-3-2	Class 3B1 acc. to IEC 60721-3-3
<b>Degree of pollution</b>	Class 2 acc. to IEC 61800-5-1	Class 2 acc. to IEC 61800-5-1	Class 2 acc. to IEC 61800-5-1
<b>Installation altitude</b>	Cabinet Modules, chassis format: up to 2000 m above sea level, without derating, > 2000 m, see characteristic curves/derating data For Motor Modules Booksize Cabinet Kit format: up to 1000 m above sea level without derating, > 1000 m, see characteristic curves/derating data		
Mechanical stability	Storage <sup>1)</sup>	Transport <sup>1)</sup>	Operation
<b>Vibration load</b>	Class 1M2 acc. to IEC 60721-3-1	Class 2M2 acc. to IEC 60721-3-2	—
• Deflection	1.5 mm at 5 ... 9 Hz	3.1 mm at 5 ... 9 Hz	0.075 mm at 10 ... 58 Hz
• Acceleration	5 m/s <sup>2</sup> at > 9 ... 200 Hz	10 m/s <sup>2</sup> at > 9 ... 200 Hz	9.8 m/s <sup>2</sup> at > 58 ... 200 Hz
<b>Shock load</b>	Class 1M2 acc. to IEC 60721-3-1	Class 2M2 acc. to IEC 60721-3-2	Class 3M4 acc. to IEC 60721-3-3
• Acceleration	40 m/s <sup>2</sup> at 22 ms	100 m/s <sup>2</sup> at 11 ms	100 m/s <sup>2</sup> at 11 ms
Compliance with standards			
<b>Conformances/approvals, according to</b>	CE (EMC Directive No. 2004/108/EC and Low-Voltage Directive No. 2006/95/EC). Optional UL listing to UL508A.		
<b>Radio interference suppression</b>	SINAMICS drive systems are not designed for connection to the public network (first environment). <u>Radio interference suppression</u> is compliant with the EMC product standard for variable speed drives IEC 61800-3, "Second environment" (industrial line supplies). The equipment can cause electromagnetic interference when it is connected to the public network.		

<sup>1)</sup> In transport packaging.

<sup>2)</sup> Deviations with respect to the specified class are underlined.

# SINAMICS S120 Cabinet Modules

## Technical data

### Technical data

The most important directives and standards are listed below. These are used as basis for the SINAMICS S120 Cabinet Modules drive system and they must be carefully observed to achieve an EMC-compliant configuration that is safe both functionally and in operation.

European directives	
<b>2006/95/EC</b>	Low-voltage directive: Legal guidelines of the EU member states concerning electrical equipment for use within specified voltage limits
<b>2004/108/EC</b>	EMC directive: Legal guidelines of the EU member states for electromagnetic compatibility
European standards	
<b>ISO 13849-1</b>	Safety of machinery – safety-related parts of control systems; Part 1: General design guidelines (ISO 13849-1: 2006) (replaces EN 954-1)
<b>IEC 60146-1-1</b>	Semiconductor converters – General requirements and line-commutated converters Part 1-1: Specification of basic requirements
<b>IEC 60204-1</b>	Safety of machinery – Electrical equipment of machines; Part 1: General requirements
<b>IEC 60529</b>	Degrees of protection provided by enclosures (IP code)
<b>IEC 61508-1</b>	Functional safety of electrical/electronic/programmable electronic safety-related systems Part 1: General requirements
<b>IEC 61800-2</b>	Variable-speed electric drives Part 2: General requirements – Rating specifications for low-voltage adjustable frequency AC power drive systems
<b>IEC 61800-3</b>	Variable-speed electric drives Part 3: EMC requirements including specific test methods
<b>IEC 61800-5-1</b>	Adjustable-speed electrical power drive systems Part 5: Safety requirements Main section 1: Electrical and thermal requirements
<b>IEC 61800-5-2</b>	Adjustable speed electrical power drive systems Part 5-2: Safety requirements – Functional safety (IEC 61800-5-2:) 2007
North American standards	
<b>NEMA ICS 7</b>	Industrial Control and Systems: Adjustable-Speed Drives
<b>NEMA ICS 7.1</b>	Safety Standards for Construction and Guide for Selection, Installation, and Operation of Adjustable-Speed Drive Systems
<b>NEMA 250</b>	Enclosures for Electrical Equipment (1000V max)
<b>UL508A (optional)</b>	Enclosed industrial control panels (options U90/U91)
<b>UL508C</b>	Power Conversion Equipment

### Characteristic curves

#### Derating data for motor modules, booksize format

SINAMICS S120 Cabinet Modules with booksize motor modules and the associated system components are rated for an ambient temperature of 104 °F (40 °C) and installation altitudes up to 3,300 ft (1,000 m) above sea level. If SINAMICS S120 Cabinet Modules with booksize motor modules are operated at ambient temperatures higher than 104 °F (40 °C) and/or installation altitudes higher than 3,300 ft (1,000 m) above sea level, then the corresponding derating factors must be taken into account as a function of the ambient temperature and/or the installation altitude.

These derating factors are different to the derating factors for the chassis format power units and are listed in Catalog PM 21.

#### Derating data for the chassis format

SINAMICS S120 Cabinet Modules and the associated system components are rated for an ambient temperature of 104 °F (40 °C) and installation altitudes up to 6,600 ft (2,000 m) above sea level.

For ambient temperatures > 104 °F (40 °C) the output current must be reduced. Ambient temperatures above 122 °F (50 °C) are not permissible.

At installation altitudes > 6,600 ft (>2,000 m) above sea level, it must be taken into consideration that with increasing altitude, the air pressure decreases and therefore the air density. As a consequence, the cooling efficiency and the insulation capacity of the air also decrease.

Due to the reduced cooling efficiency, it is necessary, on one hand, to reduce the ambient temperature and on the other hand, to lower heat loss in the Cabinet Module by reducing the output current, whereby ambient temperatures lower than 104 °F (40 °C) may be offset to compensate.

The following table specifies the permissible output current as a function of the installation altitude and ambient temperature for the various enclosure types.

The values apply under the precondition that it is guaranteed that the cooling air flow is as specified in the technical data.

Installation altitude above sea level m	Current derating factor (as a % of the rated current) for an ambient/air intake temperature of						
	68 °F (20 °C)	77 °F (25 °C)	86 °F (30 °C)	95 °F (35 °C)	104 °F (40 °C)	113 °F (45 °C)	122 °F (50 °C)
<b>For NEMA 1 and NEMA 1 filtered (IP20 to IP43) enclosures</b>							
0 to 6,600 ft (0 to 2,000 m)	100%	100%	100%	100%	100%	93.3%	86.7%
up to 8,200 ft (up to 2,500 m)	100%	100%	100%	100%	96.3%		
up to 9,800 ft (up to 3,000 m)	100%	100%	100%	98.7%			
up to 11,500 ft (up to 3,500 m)	100%	100%	100%				
up to 13,100 ft (up to 4,000 m)	100%	100%	96.3%				
up to 14,800 ft (up to 4,500 m)	100%	97.5%					
up to 16,400 ft (up to 5,000 m)	98.2%						
<b>For NEMA 12 ventilated (IP54) enclosures</b>							
0 to 6,600 ft (0 to 2,000 m)	100%	100%	100%	100%	93.3%	86.7%	80.0%
up to 8,200 ft (up to 2,500 m)	100%	100%	100%	96.3%	89.8%		
up to 9,800 ft (up to 3,000 m)	100%	100%	98.7%	92.5%			
up to 11,500 ft (up to 3,500 m)	100%	100%	94.7%				
up to 13,100 ft (up to 4,000 m)	100%	96.3%	90.7%				
up to 14,800 ft (up to 4,500 m)	97.5%	92.1%					
up to 16,400 ft (up to 5,000 m)	93.0%						

Current-derating factors for Cabinet Modules as a function of the ambient/air intake temperature, the installation altitude and the enclosure type

#### Voltage derating:

For installation altitudes from 6,600 ft (2,000 m) up to 16,400 ft (5,000 m), voltage derating is additionally required. Alternatively, voltage derating may be avoided by inserting an

isolating transformer upstream and in close proximity to the drive, to reduce transient overvoltages to levels permitted by EN 60664-1. For additional information, please refer to the [SINAMICS Low Voltage Engineering Manual](#).

## Characteristic curves

### Characteristic curves

#### Current derating for SINAMICS S120 Motors Modules, chassis format as a function of the pulse frequency

For control performance reasons or to increase output frequency, the pulse frequency can be increased relative to the factory setting. When the pulse frequency is increased, the output current needs to be derated. This derating factor must be applied to the currents specified in the technical data.

An increased pulse frequency may also be used to reduce motor noise. Note that SINAMICS S120 firmware also includes functionality that allows an increased pulse frequency without derating, when conditions permit (load, ambient temperature, and input voltage). The pulse frequency is automatically reduced if the drive approaches its thermal limits.

For additional information, please refer to the SINAMICS Low Voltage Engineering Manual.

Motor Module chassis format Order No.	Rated power at 460 (400) V kW	Rated power at 460 V HP	Rated output current $I_N$ A	Derating factor at pulse frequency				
				2.5 kHz	4 kHz	5 kHz	7.5 kHz	8 kHz
Line voltage 380 ... 480 V 3ph. AC								
6SL3720-1TE32-1AA3	125 (110)	150	210	95%	82%	74%	54%	50%
6SL3720-1TE32-6AA3	160 (132)	200	260	95%	83%	74%	54%	50%
6SL3720-1TE33-1AA3	200 (160)	250	310	97%	88%	78%	54%	50%
6SL3720-1TE33-8AA3	250 (200)	300	380	96%	87%	77%	54%	50%
6SL3720-1TE35-0AA3	300 (250)	400	490	94%	78%	71%	53%	50%

Derating factor of the output current as a function of the pulse frequency for units with a rated pulse frequency of 2 kHz

Motor Module chassis format Order No.	Rated power at 460 (400) V or 575 (690) V kW	Rated power at 460 V or 575V HP	Rated output current $I_N$ A	Derating factor at pulse frequency				
				2 kHz	2.5 kHz	4 kHz	5 kHz	7.5 kHz
Line voltage 380 ... 480 V 3ph. AC								
6SL3720-1TE36-1AA3	355 (315)	500	605	83%	72%	64%	60%	40%
6SL3720-1TE37-5AA3	450 (400)	600	745	83%	72%	64%	60%	40%
6SL3720-1TE38-4AA3	500 (450)	700	840	87%	79%	64%	55%	40%
6SL3720-1TE41-0AA3	650 (560)	800	985	92%	87%	70%	60%	50%
6SL3720-1TE41-2AA3	800 (710)	1,000	1,260	92%	87%	70%	60%	50%
6SL3720-1TE41-4AA3	900 (800)	1,150	1,405	97%	95%	74%	64%	50%
Line voltage 500 ... 600 V 3ph. AC								
6SL3720-1TG28-5AA3	60 (75)	75	85	93%	89%	71%	60%	40%
6SL3720-1TG31-0AA3	75 (90)	100	100	92%	88%	71%	60%	40%
6SL3720-1TG31-2AA3	90 (110)	125	120	92%	88%	71%	60%	40%
6SL3720-1TG31-5AA3	110 (132)	150	150	90%	84%	66%	55%	35%
6SL3720-1TG31-8AA3	132 (160)	150	175	92%	87%	70%	60%	40%
6SL3720-1TG32-2AA3	160 (200)	200	215	92%	87%	70%	60%	40%
6SL3720-1TG32-6AA3	200 (250)	250	260	92%	88%	71%	60%	40%
6SL3720-1TG33-3AA3	250 (315)	300	330	89%	82%	65%	55%	40%
6SL3720-1TG34-1AA3	300 (400)	400	410	89%	82%	65%	55%	35%
6SL3720-1TG34-7AA3	350 (450)	450	465	92%	87%	67%	55%	35%
6SL3720-1TG35-8AA3	450 (560)	600	575	91%	85%	64%	50%	35%
6SL3720-1TG37-4AA3	560 (710)	700	735	87%	79%	64%	55%	35%
6SL3720-1TG38-1AA3	630 (800)	800	810	97%	95%	71%	55%	35%
6SL3720-1TG38-8AA3	750 (900)	900	910	92%	87%	67%	55%	33%
6SL3720-1TG41-0AA3	800 (1,000)	1,000	1,025	91%	86%	64%	50%	30%
6SL3720-1TG41-3AA3	1,000 (1,200)	1,250	1,270	87%	79%	55%	40%	25%

Derating factor of the output current as a function of the pulse frequency for units with a rated pulse frequency of 1.25 kHz

The following table lists the approx. maximum output frequency as a function of pulse frequency, at default 250  $\mu$ s current controller clock cycle. Higher output frequencies are possible at higher pulse frequencies and current controller clock cycles as low as 125  $\mu$ s:

Pulse frequency	Max. output frequency
1.25 kHz	100 Hz
2.00 kHz	160 Hz
2.50 kHz	200 Hz
$\geq 4.00$ kHz	300 Hz



### Characteristic curves

#### Overload capability

SINAMICS S120 drives may be operated with both variable torque and constant torque loads at either low or high overload duties. The criterion for overload is that the drive is operated at its base load current before and after the overload occurs, based on a duty cycle duration of 300 s.

For short, repeating load cycles with significant load fluctuations within the load cycle, please refer to the appropriate sections in the SINAMICS Low Voltage Engineering Manual.

#### Motor Modules chassis format

Motor Modules with power units in the chassis format can be configured on the basis of different base load currents.

The base load current for a low overload  $I_L$  is the basis for a duty cycle of 110 % for 60 s or 150 % for 10 s.

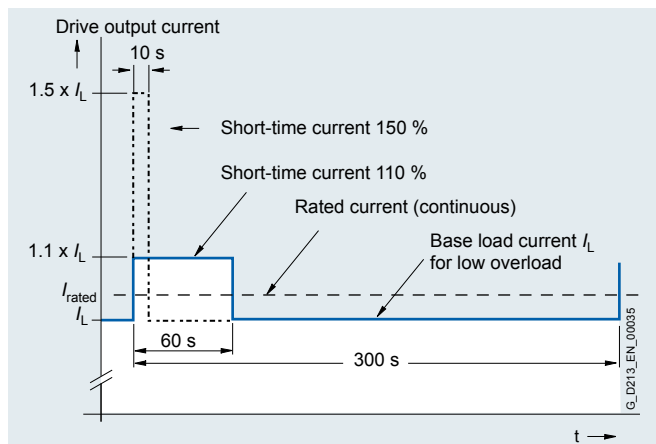

Low overload

The base load current for a high overload  $I_H$  is the basis for a duty cycle of 150 % for 60 s or 160 % for 10 s.

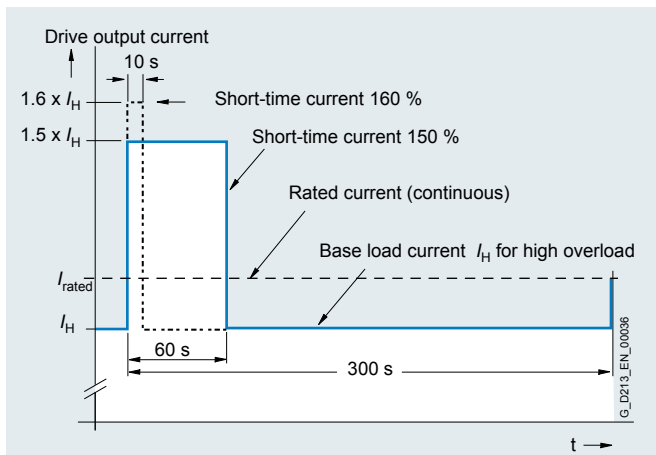

High overload

#### Motor Modules booksize format

Motor Modules with power units in the booksize format have the following overload capabilities:

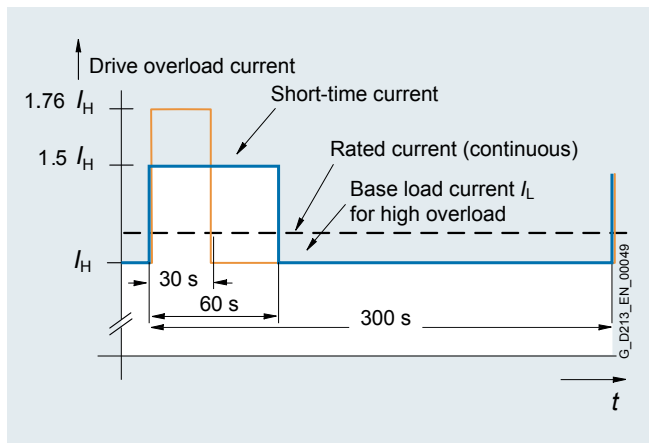

High overload

#### Line Modules chassis format

The base load current for a high overload  $I_{H DC}$  is the basis for a duty cycle of 150 % for 60s or  $I_{max DC}$  for 5 s.

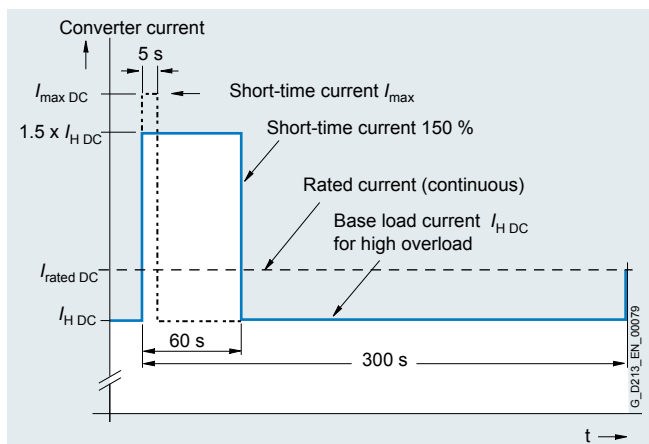

## Control units

### Overview



#### New system architecture with a central control module

In multi-axis drives, the individual drives are controlled from the higher-level control systems in such a way as to achieve the desired coordinated movement. This requires cyclic data exchange between the controller and the drives. In previous drive designs, this exchange took place via a field bus, requiring complex installation and configuration. SINAMICS takes a new approach in this respect: A central control module can control the drives for multiple axes and also establishes the technological links between the drives and/or axes. Since all the required data is stored in the central control module, it does not need to be transferred. Inter-axis connections can be established within a Control Unit and easily configured in the STARTER commissioning tool using a mouse.

- The SINAMICS Control Unit can handle simple technological tasks by itself
- The **CU320-2 DP** or **CU320-2 PN** Control Units are used in conjunction with all Motor Modules or Line Modules for single or multi-motor drives.
- Sophisticated motion control tasks can be implemented with the support of the more powerful, performance-graded Control Units **D410-2**, **D425-2**, **D435-2** and **D445-2** of SIMOTION D. Refer to Catalog PM 21 for information on SIMOTION.

Each of these Control Units is based on an object-oriented SINAMICS standard firmware, which contains all the most popular control modes and can be scaled to meet even the most advanced performance requirements.

The drive controls are supplied as ready-to-configure drive objects:

- Vector control
  - Speed-controlled drives with high speed and torque stability in general mechanical engineering systems
  - Particularly suitable for induction motors
- Servo control
  - Drives with highly dynamic motion control
  - Angular-locked synchronism with isochronous PROFIBUS/PROFINET
  - For use in machine tools and clocked production machines

The most commonly used V/Hz control modes are stored in the "Vector control" drive object and are ideal for implementing even simple applications such as group drives with SIEMOSYN motors.

#### Overview of key open-loop and closed-loop control functions.

	Closed-loop control types S120	Open-loop control types S120	Main functions S120 for booksize/chassis	Comment, note
<b>Vector control</b>	<ul style="list-style-type: none"> <li>• Induction motor                             <ul style="list-style-type: none"> <li>- Torque control with/without encoder</li> <li>- Speed control with/without encoder</li> </ul> </li> <li>• Torque motor (permanent magnet synchronous motor)                             <ul style="list-style-type: none"> <li>- Torque control with encoder</li> <li>- Speed control with/without encoder</li> </ul> </li> <li>• For induction and torque motors                             <ul style="list-style-type: none"> <li>- Position control with encoder</li> </ul> </li> </ul>	<ul style="list-style-type: none"> <li>- Linear V/Hz characteristic</li> <li>- Constant-frequency V/Hz characteristic (textile)</li> <li>- Independent voltage setpoint input</li> </ul>	<ul style="list-style-type: none"> <li>• Data set changeover</li> <li>• Extended setpoint input</li> <li>• Motor identification</li> <li>• Current/speed controller optimization</li> <li>• Technology controller</li> <li>• Basic positioner</li> <li>• Automatic restart</li> <li>• Flying restart with /without encoder</li> <li>• Kinetic buffering</li> <li>• Synchronization</li> <li>• Droop</li> <li>• Brake control</li> </ul>	<p>Mixed operation with V/Hz control modes is possible; it is for this reason that the V/Hz control modes are stored only once in the "Vector control" drive object.</p> <p>Position control can be selected as a function module from both Servo and Vector mode.</p> <p>Permanent-magnet 1FW4 synchronous motors can be operated over the complete operating range in Vector control.</p>
<b>Servo control</b>	<ul style="list-style-type: none"> <li>• Induction motor                             <ul style="list-style-type: none"> <li>- Torque control with/without encoder</li> <li>- Speed control with/without encoder</li> </ul> </li> <li>• Synchronous motor, linear motor and torque motor                             <ul style="list-style-type: none"> <li>- Torque control with encoder</li> <li>- Speed control with/without encoder</li> </ul> </li> <li>• For all motor types                             <ul style="list-style-type: none"> <li>- Position control with encoder</li> </ul> </li> </ul>	<ul style="list-style-type: none"> <li>- Linear V/Hz characteristic</li> <li>- Constant-frequency V/Hz characteristic (textile)</li> <li>- Independent voltage setpoint input</li> </ul>	<ul style="list-style-type: none"> <li>• Data set changeover</li> <li>• Setpoint input</li> <li>• Motor identification</li> <li>• Damping application</li> <li>• Technology controller</li> <li>• Basic positioner</li> <li>• Brake control</li> </ul>	<p>Mixed operation with V/Hz control modes is possible; it is for this reason that the V/Hz control modes are stored only once in the "Vector control" drive object.</p> <p>Position control can be selected as a function module from both Servo and Vector mode.</p>

### Overview

#### Drive objects

A drive object is a self-contained software function with its own parameters and, if necessary, its own fault messages and alarms.

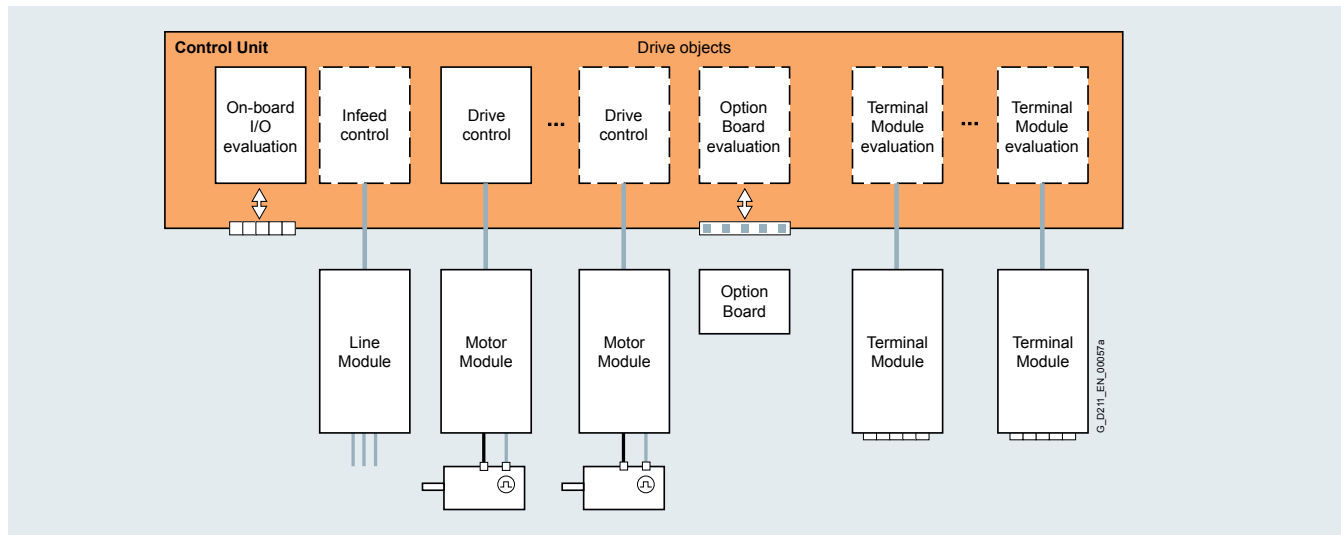

#### Comprehensive package of open-loop and closed-loop control functions

A wide variety of standard functions such as setpoint input, data set changeover, controller optimization, kinetic buffering, etc. ensure a high degree of functional reliability and excellent flexibility when addressing the application.

#### BICO technology

Every drive object contains a large number of input and output variables which can be freely and independently interconnected using Binector Connector Technology (BICO). A binector is a logic signal which can assume the value 0 or 1. A connector is a numerical value, e.g. the actual speed or current setpoint.

#### Drive Control Chart (DCC)

Drive Control Chart (DCC) is an additional option for the easy configuration of technological functions for SINAMICS.

The block library encompasses a large selection of closed-loop, arithmetic and logic blocks, as well as a more comprehensive range of open-loop and closed-loop control functions. The user friendly DCC Editor enables easy graphics-based configuration, allows control loop structures to be clearly represented and provides a high degree of reusability of diagrams that have already been created. DCC is an add-on to the STARTER commissioning tool.

#### CompactFlash card

The functions of the drives are stored on a CompactFlash card. This card contains the firmware and parameter settings for all drives in the form of a project. The CompactFlash card can also hold additional projects, which means that the correct project can be accessed immediately when series machines of different types are commissioned. When the Control Unit has booted, the data on the CompactFlash card is read and loaded to the RAM.

The firmware is organized in objects. Drive objects are used to implement open-loop and closed-loop control functions for Line Modules, Motor Modules, Power Modules and other system components connected by DRIVE-CLiQ.

#### Integral safety functions (Safety Integrated)

The Control Units support an extensive range of safety functions.

The integrated safety functions are the Safety Integrated Basic functions

- STO = Safe Torque Off
  - SBC = Safe Brake Control
  - SS1 = Safe Stop 1 (Time controlled)
- and the Safety Integrated Extended functions that require a license
- STO = Safe Torque Off
  - SS1 = Safe Stop 1 (time and acceleration controlled)
  - SS2 = Safe Stop 2
  - SOS = Safe Operating Stop
  - SLS = Safely Limited Speed
  - SSM = Safe Speed Monitor
  - SDI = Safe Direction

If the integrated safety functions are used, licenses, supplementary system components such as TM54F Terminal Modules, or suitable safety controls may be necessary.

#### Diagnostics optimally supported by trace function

The time characteristics of input and output variables associated with drive objects can be measured by the integrated trace function and displayed using the STARTER commissioning tool. Several signals can be simultaneously traced. A recording can be triggered as a function of freely selectable boundary conditions, e.g. the value of an input or output variable.

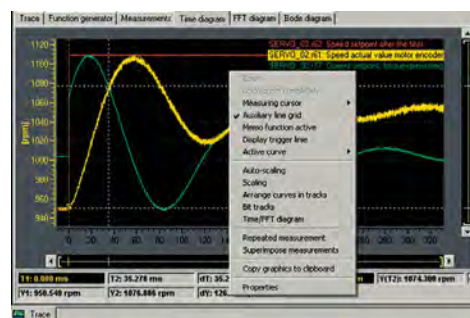

## Control units

### Function

#### Software and protective functions

A selection of commonly used standard functions is described below:

Software and protective functions	Description
<b>Setpoint input</b>	The setpoint can be input both internally and externally. It is applied internally as a fixed set point, motorized potentiometer setpoint or jog setpoint and externally via the communications interface or an analog input on the customer terminal block. The internal fixed setpoint and the motorized potentiometer setpoint can be switched over or adjusted using control commands from any interface.
<b>Motor identification</b>	The automatic motor identification function makes commissioning faster and easier and optimizes closed-loop control of the drive.
<b>Ramp-function generator</b>	A user-friendly ramp-function generator with separately adjustable ramp up and ramp down times, together with adjustable rounding times in the lower and upper speed ranges, allows the drive to be smoothly accelerated and braked. This results in a good speed control response and plays its role in reducing the stress on the mechanical system. The down ramp can be parameterized separately for a quick stop.
<b>V<sub>dc max</sub> controller</b>	The V <sub>dc max</sub> controller automatically prevents overvoltages in the DC link if the down ramp is too short, for example. This may also extend the set ramp-down time. <u>Comment:</u> This function only makes sense for single-axis applications.
<b>Kinetic buffering (KIP)</b>	For brief line supply failures, the kinetic energy of the rotating machine is used to buffer the DC bus and therefore prevents fault trips. The drive converter remains operational as long as the drive can provide regenerative energy as a result of its motion and the DC link voltage does not drop below the shutdown threshold. When the line supply recovers within this time, the drive is again bumplessly accelerated up to its setpoint speed.
<b>Automatic restart</b>	The automatic restart switches the drive on again when the power is restored after a power failure, and ramps up to the current speed setpoint.
<b>Flying restart</b>	The flying restart function allows the drive to be switched to a motor that is still turning.
<b>Technology controller</b>	Using the technology controller (PID controller) function module, level or flow controls and complex tension controls can be implemented, for example. The existing D component can act both on the system deviation as well as on the actual value (factory setting). The P, I, and D components are separately set.
<b>Free function blocks</b>	Using the freely programmable function blocks, it is easy to implement logic and arithmetic functions for controlling the SINAMICS drive. The blocks can be programmed by means of an operator panel or the STARTER commissioning tool.
<b>Drive Control Chart (DCC)</b>	Drive Control Chart (DCC) is an additional tool for the easy configuration of technological functions for SINAMICS. The block library contains a large selection of control, arithmetic and logic blocks as well as extensive open-loop and closed loop control functions. The user-friendly DCC Editor enables easy graphics-based configuration, allows control loop structures to be clearly represented and provides a high degree of reusability of diagrams that have already been created. DCC is an add-on to the STARTER commissioning tool (→ Tools and engineering).
<b>I<sup>2</sup>t detection for motor protection</b>	A motor model in the drive firmware calculates the motor temperature based on the current speed and load. More exact sensing of the temperature, which also takes into account the influence of the ambient temperature, is possible by means of direct temperature sensing using KTY84 sensors in the motor winding.
<b>Motor temperature evaluation</b>	Motor protection by evaluating a KTY84, PTC or Pt100 temperature sensor. When a KTY84 temperature sensor is connected, the limit values can be set for alarm or shutdown. When a PTC thermistor is connected, the system reaction to triggering of the thermistor (alarm or shutdown) can be defined.
<b>Motor blocking protection</b>	A blocked motor is detected and protected against thermal overloading by a fault trip.

#### Power unit protection

Power unit protection	Description
<b>Ground fault monitoring at the output</b>	A ground fault at the output end is detected by an aggregate current monitor and results in shutdown in grounded-neutral systems.
<b>Electronic short-circuit protection at the output</b>	A short-circuit at the output (e.g. at the drive output terminals, in the motor cable or in the motor terminal box) is detected and the drive shuts down with a "fault."
<b>Thermal overload protection</b>	An alarm is issued first when the overtemperature threshold responds. If the temperature continues to rise, the unit either shuts down or independently adjusts the pulse frequency or output current so that thermal load is reduced. Once the cause of the fault has been eliminated (e.g. cooling has been improved), the original operating values are automatically resumed.

### Overview



The communication, open-loop and closed-loop control functions for one or more Line Modules and/or Motor Modules are executed in the CU320-2 Control Unit.

Two versions of the CU320-2 Control Unit are available, with different bus communication protocols:

- CU320-2 DP (**option K90**) with one PROFIBUS interface with PROFIdrive profile
- CU320-2 PN (**option K95**) with a PROFINET interface with PROFIdrive profile

Additional bus communication protocols are available by inserting a communications module in the option slot.

### Design

The CU320-2 Control Unit has the following interfaces as standard:

- 4 x DRIVE-CLiQ sockets for communication with other DRIVE-CLiQ nodes, e.g. Motor Modules, Active Line Modules, Sensor Modules, Terminal Modules
- 12 parameterizable digital inputs (isolated)
- 8 parameterizable bidirectional digital inputs/digital outputs (non-floating)
- 1 serial RS232 interface (e.g. to connect the AOP30 Advanced Operator Panel)

- 1 interface for the BOP20 Basic Operator Panel
- 1 slot for the CompactFlash card on which firmware and parameters are stored
- 1 slot for mounting an option module (e.g. TB30 Terminal Board or CBE20 Communications Board Ethernet)
- 2 rotary coding switches for manually setting the PROFIBUS address
- 1 Ethernet interface for commissioning and diagnostics
- 3 test sockets and one reference ground for commissioning support
- 1 connection for the electronics power supply via the 24 V DC supply connector
- 1 PE/protective conductor connection
- 1 ground connection

A shield connection for the signal cable shield on the option module is located on the CU320-2 Control Unit.

The available option slot is used to expand the interfaces, e.g. terminals or communication.

The status of the CU320-2 Control Unit is indicated via multi-color LEDs.

As the firmware and parameter settings are stored on a plug-in CompactFlash card, the Control Unit can be changed without the need for software tools.

### Integration

DRIVE-CLiQ components such as Motor Modules and Active Line Modules can be connected to a CU320-2 Control Unit. The number of modules depends on the performance required, including duty type and additional functions.

The CU320-2 Control Unit and other connected components are commissioned and diagnosed using the STARTER commissioning tool from Version 4.1 SP5 and the installed SINAMICS Support Package SSP\_SINAMICS\_V4\_3\_2 or the AOP30 Advanced Operator Panel.

The BOP20 Basic Operator Panel can also be snapped onto the CU320-2 Control Unit during operation for troubleshooting. The CU320-2 Control Unit requires a CompactFlash card with firmware.

## CU320-2 Control Unit

### Technical data

CU320-2 Control Unit	
<b>Current demand, max.</b> At 24 V DC, without taking into account digital outputs, expansion option slot and DRIVE-CLiQ supply	1.0 A
<b>Digital inputs</b> <ul style="list-style-type: none"> <li>• Voltage</li> <li>• Low level (an open digital input is interpreted as "low")</li> <li>• High level</li> <li>• Current consumption at 24 V DC, typ.</li> <li>• Delay time of digital inputs<sup>1)</sup>, approx.                             <ul style="list-style-type: none"> <li>- L → H</li> <li>- H → L</li> </ul> </li> <li>• Delay time of high-speed digital inputs<sup>1)</sup>, approx.                             <ul style="list-style-type: none"> <li>- L → H</li> <li>- H → L</li> </ul> </li> <li>• Conductor cross-section, max.</li> </ul>	In accordance with IEC 61131-2 Type 1 12 isolated digital inputs 8 bidirectional non-isolated digital inputs/digital outputs -3 ... +30 V -3 ... +5 V 15 ... 30 V 9 mA 50 µs 100 µs 5 µs 50 µs #14 AWG (1.5 mm <sup>2</sup> )
<b>Digital outputs</b> Continuously short-circuit proof <ul style="list-style-type: none"> <li>• Voltage</li> <li>• Load current per digital output, max.</li> <li>• Delay time<sup>1)</sup>, typ./max.                             <ul style="list-style-type: none"> <li>- L → H</li> <li>- H → L</li> </ul> </li> <li>• Conductor cross-section, max.</li> </ul>	8 bidirectional non-isolated digital inputs/digital outputs 24 V DC 500 mA 150 µs/400 µs 75 µs/100 µs #14 AWG (1.5 mm <sup>2</sup> )
<b>Power loss</b>	24 W
<b>Conformity</b>	CE
<b>Approvals, according to</b>	cULus

1) The specified delay times refer to the hardware. The actual reaction time depends on the time slot in which the digital input or output is processed.

### Overview



The CompactFlash card contains the firmware and parameter settings. The CompactFlash card is plugged into the appropriate slot on the CU320-2 Control Unit

### Design

A CU320-2 Control Unit can perform the communication, open loop and closed-loop control functions for several power units. The computing capacity requirement increases in proportion to the number of power units and system components and in relation to the dynamic response required. The computing capacity requirement and utilization of the CU320-2 Control Unit can be calculated with the SIZER for Siemens Drives engineering tool. The full computing capacity of the CU320-2 Control Unit is only available on systems with performance expansion (**option K94**). For the CU320-2 Control Unit, the performance expansion is necessary from the 4th axis.

In addition to the firmware, the CompactFlash card also contains licensing codes that are required to enable firmware options (currently, the performance expansion and the Safety Integrated Extended Functions). The Safety Integrated Extended Functions must be ordered for each axis via option codes (**K01 to K05**).

### Overview



The CBE20 Communication Board (**option G33**) is required, if

- a CU320-2 DP (PROFIBUS) Control Unit, is to be connected to a PROFINET-IO network
- a CU320-2 DP (PROFIBUS) or CU320-2 PN (PROFINET) Control Unit is to be connected to an EtherNet/IP network
- SINAMICS Link is to be used to directly exchange data between several CU320-2 DP (PROFIBUS) or CU320-2 PN (PROFINET) Control Units without using a higher-level control system.

The CBE20 is parameterized to operate in one of these modes. In addition, the CBE20 allows Standard Ethernet TCP/IP communication for engineering processes using the STARTER commissioning tool on a PROFINET or EtherNet/IP network:

#### PROFINET

With the CBE20 Communication Board, SINAMICS S120 is a PROFINET IO device in the sense of PROFINET and can perform the following functions:

- PROFINET IO device
- 100 Mbit/s full duplex
- Supports real-time classes of PROFINET IO:
  - RT (Real-Time)
  - IRT (Isochronous Real-Time), minimum send cycle 500  $\mu$ s
- Connects to controls as PROFINET IO devices according to the PROFIdrive profile
- Integrated 4-port switch with four RJ45 sockets based on the PROFINET ASIC ERTEC400. The optimum topology (line, star, tree) can therefore be configured without additional external switches.

#### EtherNet/IP

EtherNet/IP (EtherNet Industrial Protocol) is an open standard predominantly used in the automation industry. EtherNet/IP is supported by the Open DeviceNet Vendor Association (ODVA).

#### SINAMICS Link

SINAMICS Link can be used to directly exchange data between several CU320-2 DP (PROFIBUS) or CU320-2 PN (PROFINET) Control Units without using a higher-level control system. Possible applications for the SINAMICS Link include:

- Torque sharing for several drives
- Setpoint cascading for several drives
- Load distribution for drives coupled through a material web
- Coordination between SINAMICS G or SINAMICS S with the CU320-2 Control Unit and SINAMICS DC Master with CUD Control Units.

Only CU320-2 Control Units or CUD Control Units of the SINAMICS DC Master can be integrated into this communication network.

SINAMICS Link is activated by appropriately parameterizing the Control Units of the participants.

#### Integration

The CBE20 Communication Board plugs into the option slot on the CU320-2 Control Unit.

#### Technical data

CBE20 Communication Board	
Current demand at 24 V DC	0.16 A
Conformity	CE
Approvals, according to	cULus

# SINAMICS S120 Cabinet Modules

## BOP20 Basic Operator Panel

### Overview



BOP20 Basic Operator Panel

The BOP20 Basic Operator Panel can be snapped onto a CU320-2 Control Unit and may be used to acknowledge faults, set parameters and read diagnostic information (e.g. alarm and fault messages).



CU320-2 Control Unit with inserted BOP20 Basic Operator Panel

### Design

The BOP20 Basic Operator Panel has a backlit two-line display area and 6 keys.

The integrated plug connector on the rear side of the BOP20 Basic Operator Panel provides the power to the BOP20 Basic Operator Panel and the communication with the CU320-2 Control Unit.

### Selection and ordering data

Description	Order No.
BOP20 Basic Operator Panel	6SL3055-0AA00-4BA0



### Overview



The AOP30 Advanced Operator Panel can be added to a CU320-2 Control Unit (**option K08**), and is mounted in the cabinet door.

It has the following features and characteristics:

- Graphical backlit LCD display (240 × 64 pixels) for plain text, bar graphs or trend of process variables
- LEDs for display of operating modes
- Help function describing causes of and remedies for faults and alarms
- 26-key membrane keyboard for operational control of a drive
- Local/remote switchover for selecting the operating location (priority assigned to operator panel or customer terminal block/PROFIBUS/PROFINET)
- Numeric keypad for input of setpoint or parameter values
- Function keys for prompted navigation in the menu
- 4 LEDs to signal the operating state of the drive:
  - RUN: green
  - ALARM: yellow
  - FAULT: red
  - Local/Remote: green

- Two-stage safety concept to protect against accidental or unauthorized changes to settings.
  - Operation of the drive from the operator panel can be disabled by the keyboard lock so that only parameter values and process variables can be displayed on the operating panel.
  - A password can be used to prevent the unauthorized modification of drive parameters.
- Front panel with degree of protection IP55

If just one CU320-2 Control Unit controls several power units (multi-motor operation), then the parameters, alarms and faults relating to all the devices connected can be displayed and processed.

### Function

The current operating states, setpoints and actual values, parameters, indices, faults and alarms are displayed on the display panel.

Chinese, German, English, French, Italian and Spanish are stored on the CU320-2 Control Unit CompactFlash card as operator panel languages. The desired language must be downloaded to the AOP30 prior to commissioning.

On request, Russian, Polish, and Czech are available in addition to these languages installed as standard. These can be downloaded free of charge from the Internet under the following link: <http://support.automation.siemens.com>

### Technical data

AOP30 Advanced Operator Panel	
Current demand at 24 V DC	0.16 A
Conformity	CE
Approvals, according to	cULus

# SINAMICS S120 Cabinet Modules

## Customer Terminal Block -X55

### Overview

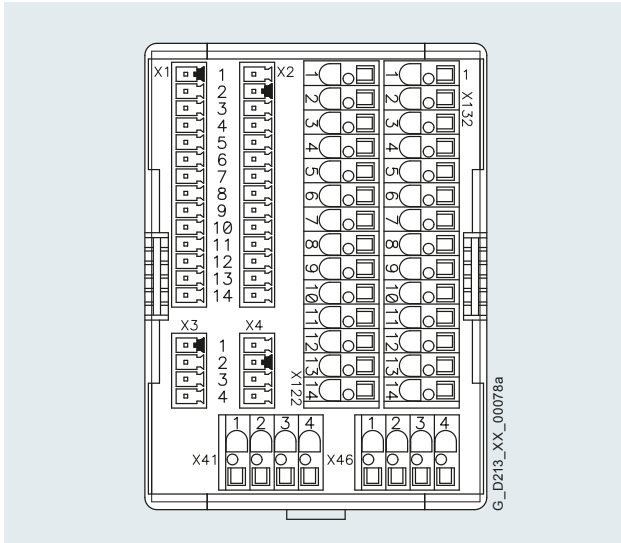

Customer terminal block -X55 represents the interface to the I/O devices and marshals a range of cabinet-internal signals to a central terminal block module mounted in the lower part of the cabinet.

It can be used for Motor Modules in the chassis format as well as together with options K90 (CU320-2 DP Control Unit) or K95 (CU320-2 PN Control Unit) for Basic Line Modules, Smart Line Modules, Active Line Modules and Booksize Cabinet Kits.

### Design

To connect signal cables on the customer side, terminal block -X55 includes terminals -X122, -X132, -X41 and -X46 (terminals -X1 to -X4 are used inside the cabinet and are not available). As a consequence, depending on the version (with/without option **K90** or **K95**) the following digital inputs/outputs and/or signals are available:

The customer terminal block -X55 includes:	Motor Modules chassis format		Line Modules	
	Without	with	Without	with
	CU320-2 ( <b>K90/K95</b> )		CU320-2 ( <b>K90/K95</b> )	
<b>-X122, -X132</b>				
12 digital inputs DI	–	✓	–	✓
8 bidirectional inputs/outputs (DI/DO)	–	✓	–	✓
<b>-X41</b>				
Connection, safety function Safe Torque Off/Safe Stop 1	✓	✓	– 1)	– 1)
Connection temperature sensor KTY84/PTC/Pt100	✓	✓	– 1)	– 1)
<b>-X46</b>				
Connection, Safe Brake Adapter	✓	✓	–	–

1) For Booksize Cabinet Kits, a connection is provided at the separate customer terminal block -X55.1 or -X55.2.

### Overview

#### Pin assignment

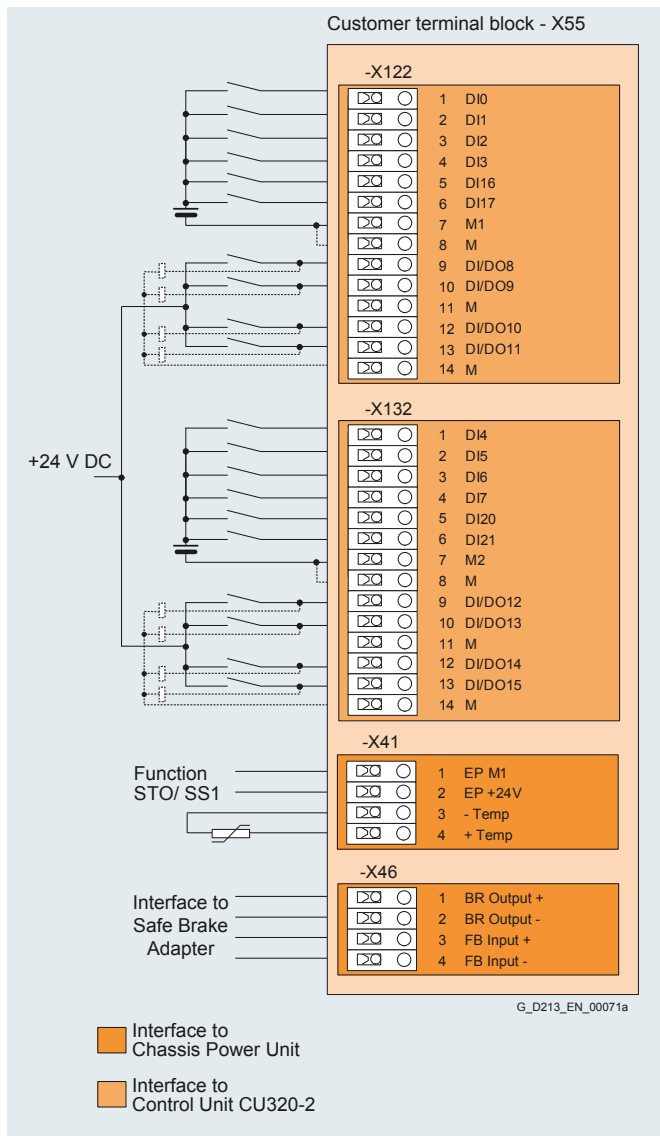

Terminal assignment of customer terminal block -X55

#### Terminal block -X55-X122 digital inputs/outputs

Terminal	Designation <sup>1)</sup>	Technical data
1	DI 0	Voltage -30 V to +30 V DC Current drain, typical: 9 mA at 24 V DC Electrical isolation: Terminal M1 is the reference potential Level (including ripple): High level: 15 V ... 30 V Low level: -30 V ... +5 V Input delay (typ.): at 0 → 1: 50 μs at 1 → 0: 150 μs
2	DI 1	
3	DI 2	
4	DI 3	
5	DI 16	
6	DI 17	
7	M1	Reference potential for terminals 1 to 6
8	M	Ground
9	DI/DO 8	As input:
10	DI/DO 9	Voltage -30 V ... +30 V DC Current drain, typical: 9 mA at 24 V DC
11	M	
12	DI/DO 10	Level (including ripple): High level: 15 V ... 30 V Low level: -30 V ... +5 V
13	DI/DO 11	
14	M	Fast inputs: <sup>2)</sup> DI/DO 8, 9, 10 and 11 Input delay (typ.): at 0 → 1: 5 μs at 0 → 0: 50 μs
		As output: Voltage 24 V DC Max. load current for each output: 500 mA continuously short-circuit proof Output delay (typ./max.): <sup>3)</sup> at 0 → 1: 150 μs/400 μs at 1 → 0: 75 μs/100 μs Switching frequency: For resistive load: max. 100 Hz For inductive load: max. 0.5 Hz For lamp load: max. 10 Hz Max. lamp load: 5 W

Maximum wire size: #14 AWG (1.5 mm<sup>2</sup>)

1) DI: Digital input  
DI/DO: bidirectional digital input/output  
M: Electronics ground  
M1: Reference ground  
2) Can be used as measuring probe input or input for the external zero mark.  
3) Data for:  $U_{CC} = 24 \text{ V}$ ; load  $48 \Omega$ ; High (1) = 90 %  $U_{Out}$ ; Low (0) = 10 %  $U_{Out}$ .

## Customer Terminal Block – X55

### Design

#### Terminal block -X55-X132 digital inputs/outputs

Terminal	Designation <sup>1)</sup>	Technical data
1	DI 4	Voltage -30 V to +30 V DC Current drain, typical: 9 mA at 24 V DC Electrical isolation: Terminal M2 is the reference potential Level (including ripple): High level: 15 V ... 30 V Low level: -30 V ... +5 V Input delay (typ.): at 0 → 1: 50 μs at 1 → 0: 150 μs
2	DI 5	
3	DI 6	
4	DI 7	
5	DI 20	
6	DI 21	
7	M2	Reference potential for terminals 1 to 6
8	M	Ground
9	DI/DO 12	<u>As input:</u> Voltage -30 V ... +30 V DC Current drain, typical: 9 mA at 24 V DC Level (including ripple): High level: 15 V ... 30 V Low level: -30 V ... +5 V Fast inputs: <sup>2)</sup> DI/DO 12, 13, 14 and 15 Input delay (typ.): at 0 → 1: 5 μs at 0 → 0: 50 μs <u>As output:</u> Voltage 24 V DC Max. load current for each output: 500 mA continuously short-circuit proof Output delay (typ./max.): <sup>3)</sup> at 0 → 1: 150/400 μs at 1 → 0: 75 μs/100 μs Switching frequency: For resistive load: max. 100 Hz For inductive load: max. 0.5 Hz For lamp load: max. 10 Hz Max. lamp load: 5 W
10	DI/DO 13	
11	M	
12	DI/DO 14	
13	DI/DO 15	
14	M	

Maximum wire size: #14 AWG (1.5 mm<sup>2</sup>)

#### Terminal block -X55-X41 temperature sensor connection

Terminal	Function	Technical data
1	EP M1 (enable pauses)	Supply voltage 24 V DC (20.4 ... 28.8 V) Current drain: 10 mA Signal propagation times: L → H: 100 μs H → L: 1000 μs The pulse inhibit function is only provided if Safety Integrated Basic Functions have been enabled
2	EP +24 V (enable pauses)	
3	- Temp	Temperature sensor connection for motor temperature sensing: KTY84-1C130, PTC, Pt100
4	+ Temp	

Maximum wire size: #12 AWG (2.5 mm<sup>2</sup>)

#### Terminal block -X55-X46 brake control and monitoring

Terminal	Function	Technical data
1	BR output +	The interface is used to connect the Safe Brake Adapter
2	BR output -	
3	FB input +	
4	FB input -	

Maximum wire size: #14 AWG (1.5 mm<sup>2</sup>)

1) DI: Digital input  
 DI/DO: bidirectional digital input/output  
 M: Electronics ground  
 M2: Reference ground  
 2) Can be used as measuring probe input or input for the external zero mark.  
 3) Data for:  $U_{cc} = 24\text{ V}$ ; load  $48\ \Omega$ ; High (1) = 90 %  $U_{out}$ ; Low (0) = 10 %  $U_{out}$ .

### Overview



The SMC10 Sensor Module Cabinet-Mounted (**option K46**) is required to evaluate the encoder signals of motors without a DRIVE-CLiQ interface. External encoders can also be connected via the SMC10.

The following encoder signals can be evaluated:

- 2-pole resolver
- Multipole resolver

### Design

The SMC10 Sensor Module Cabinet-Mounted features the following interfaces as standard:

- 1 encoder connection including motor temperature detection (KTY84-130 or PTC) via SUB-D connector

The status of the SMC10 Sensor Module Cabinet-Mounted is indicated via a multi-color LED.

The signal cable shield can be connected via the encoder system and can also be connected to the SMC10 Sensor Module via shield connection terminal, e.g. Phoenix Contact type SK8 or Weidmüller type KLBÜ CO 1.,

### Technical data

#### SMC10 Sensor Module Cabinet-Mounted

<b>Current demand, max.</b> At 24 V DC, without taking encoder into account	0.2 A
<b>Power loss max.</b>	10 W
<b>Encoders which can be evaluated</b>	<ul style="list-style-type: none"> <li>• 2-pole resolver</li> <li>• Multipole resolver</li> </ul>
• Excitation voltage, rms	4.1 V
• Excitation frequency	5 ... 10 kHz depending on the current controller clock cycle of the Motor Module or Power Module
• Transformation ratio	0.5
• Encoder frequency, max.	2 kHz (120,000 rpm) depending on the pole pair number of the resolver and the current controller clock cycle of the Motor Module or Power Module
• Signal subdivision (interpolation), max.	16,384 times (14 bit)
• Cable length to encoder, max.	426 ft (130 m)
<b>Conformity</b>	CE
<b>Approvals, according to</b>	cULus

## SMC20 Sensor Module

### Overview



The SMC20 Sensor Module Cabinet-Mounted (**option K48**) is required to evaluate the encoder signals of motors without a DRIVE-CLiQ interface. External encoders can also be connected via the SMC20.

The following encoder signals can be evaluated:

- Incremental encoder sin/cos 1 V<sub>pp</sub>
- EnDat absolute encoder
- SSI encoder with TTL/HTL incremental signals sin/cos 1 V<sub>pp</sub> (firmware version 2.4 and later)
- SSI encoder without incremental signals

The motor temperature can also be detected with KTY84-130 or PTC thermistors.

### Design

The SMC20 Sensor Module Cabinet-Mounted features the following interfaces as standard:

- 1 encoder connection including motor temperature detection (KTY84-130 or PTC) via SUB-D connector or terminals

The status of the SMC20 Sensor Module Cabinet-Mounted is indicated via a multi-color LED.

The signal cable shield can be connected via the encoder system and can also be connected to the SMC20 Sensor Module Cabinet-Module via shield connection terminal, e.g. Phoenix Contact type SK8 or Weidmüller type KLBÜ CO 1.

### Technical data

#### SMC20 Sensor Module Cabinet-Mounted

<b>Current demand, max.</b> At 24 V DC, without taking encoder into account	0.2 A
<b>Power loss max.</b>	10 W
<b>Encoders which can be evaluated</b>	<ul style="list-style-type: none"> <li>• Incremental encoder sin/cos 1 V<sub>pp</sub></li> <li>• EnDat absolute encoder</li> <li>• SSI encoder with incremental signals sin/cos 1 V<sub>pp</sub> (firmware version 2.4 and later)</li> </ul>
• Encoder supply	5 V DC/0.35 A
• Encoder frequency incremental signals, max	500 kHz
• Signal subdivision (interpolation), max.	16,384 times (14 bit)
• SSI baud rate	100kBaud
• Cable length to encoder, max.	426 ft (130 m)
<b>PE connection</b>	M4 screw
<b>Conformity</b>	CE
<b>Approvals, according to</b>	cULus

### Overview



The SMC30 Sensor Module Cabinet-Mounted (options K50 and K52) is required to evaluate the encoder signals of motors without a DRIVE-CLiQ interface. External encoders can also be connected via the SMC30.

The following encoder signals can be evaluated:

- Incremental encoders TTL/HTL with/without open-circuit detection (open-circuit detection is only available with bipolar signals)
- SSI encoder with TTL/HTL incremental signals
- SSI encoder without incremental signals

The motor temperature can also be detected with KTY84-130 or PTC thermistors.

### Design

The SMC30 Sensor Module Cabinet-Mounted features the following interfaces as standard:

- 1 encoder connection including motor temperature detection (KTY84-130 or PTC) via SUB-D connector or terminals

The status of the SMC30 Sensor Module Cabinet-Mounted is indicated via a multi-color LED.

The maximum encoder cable length between SMC30 modules and encoders is 330 ft (100 m). For HTL encoders, this length can be increased to 990 ft (300 m) if the A\*, A and B\*, B signals are evaluated and the power supply cable has a minimum cross-section of #20 AWG (0.5 mm<sup>2</sup>).

The signal cable shield can be connected to the SMC30 Sensor Module Cabinet-Mounted via a shield connection terminal, e.g. Phoenix Contact type SK8 or Weidmüller type KLBÜ CO 1.

### Technical data

#### SMC30 Sensor Module Cabinet-Mounted

<b>Current demand, max.</b> At 24 V DC, without taking encoder into account	0.2 A
<b>Power loss max.</b>	10 W
<b>Encoders which can be evaluated</b>	<ul style="list-style-type: none"> <li>• Incremental encoder TTL/HTL</li> <li>• SSI encoder with TTL/HTL incremental signals</li> <li>• SSI encoder without incremental signals</li> </ul>
<ul style="list-style-type: none"> <li>• Input impedance</li> <li>- TTL</li> <li>- HTL, max.</li> </ul>	570 Ω 16 mA
• Encoder supply	24 V DC/0.35 A or 5 V DC/0.35 A
• Encoder frequency max.	300 kHz
• SSI baud rate	100 ... 250 kBaud
• Limiting frequency, max.	300 kHz
• Resolution absolute position SSI	30 bit
• Cable length, max.	
- TTL encoder	330 ft (100 m) (only bipolar signals permitted) <sup>1)</sup>
- HTL encoder	330 ft (100 m) for unipolar signals 990 ft (300 m) for bipolar signals <sup>1)</sup>
- SSI encoder	330 ft (100 m)
<b>Conformity</b>	CE
<b>Approvals, according to</b>	cULus

<sup>1)</sup> Signal cables twisted in pairs and shielded.

## TM150 Terminal (RTD) Module

### Overview



The TM150 RTD module (option **G51** to **G54** in the Line Connection Module) is suitable for monitoring a variety of temperature sensors, over the temperature range -146°F (-99°C) to +480°F (+250°C):

- Pt100 - Platinum RTD 100 ohm
- Pt1000 - Platinum RTD 1,000 ohm
- KTY84 - temperature sensor
- PTC - Positive temperature coefficient thermistor
- Temperature switch (NC) contact (for example Thermoclick or bimetallic switch)

Up to 12 sensors in 2-wire connection or up to 6 sensors in 3- or 4-wire connection can be connected to one TM150. The TM150 detects wire breakage or a short circuit in the RTD leads for Pt100, Pt1000 and KTY84 sensors, and short circuit for PTC thermistors.

Temperature values from the TM150 are available for further processing. Motor winding temperatures can be used for the thermal motor model in the closed loop control. Temperature values can be displayed on the AOP30, and transmitted to the process control system via bus communications.

Note: TM150 inputs are not galvanically isolated. Only temperature sensors isolated per IEC 61800-5-1 may be connected to terminals "+Temp" and "-Temp". Failure to observe these instructions can result in electric shock!

### Technical data

#### TM150 Terminal Module

Current demand at 24 V DC	0.5 A
Conformity	CE
Approvals, according to	cULus



### Overview



The VSM10 Voltage Sensing Module (option **K51**) allows the line supply or motor voltage characteristic to be precisely sensed. The VSM10 Voltage Sensing Module is integrated in Active Interface Modules chassis format and in Smart Line Modules chassis format.

In addition, the VSM10 is used to switch to a rotating synchronous motor (flying restart function).

### Design

The VSM10 Voltage Sensing Module has the following interfaces:

- 1 connection for direct voltage sensing up to 690 V
- 1 connection for voltage sensing using voltage transformers, max. 100 V 3 ph.
- 2 analog inputs (reserved for resonance monitoring in Active Interface Modules)
- 1 temperature sensor input (KTY84-130 or PTC)

The status of the VSM10 Voltage Sensing Module is indicated by a two-color LED.

### Technical data

#### VSM10 Voltage Sensing Module

<b>Current demand, max. at 24 V DC</b>	0.2 A
<b>Power loss</b>	<5 W
<b>Line voltage detection</b>	
• Input resistance	
- Terminal X521	> 362 kΩ/phase
- Terminal X522	> 2.5 MΩ/phase
<b>Conformity</b>	CE
<b>Approvals, according to</b>	cULus

# SINAMICS S120 Cabinet Modules

## Connection system Signal cables

### Overview



MOTION-CONNECT DRIVE-CLiQ cable

Signal cables are pre-assembled and are sold by the meter for the connection of a variety of components.

- DRIVE-CLiQ cables
- MOTION-CONNECT DRIVE-CLiQ cables
- MOTION-CONNECT pre-assembled cables

### Applications

#### DRIVE-CLiQ cables

are used to connect components with DRIVE-CLiQ connections which have a separate or external 24 V DC power supply.

DRIVE-CLiQ cables for connecting Line/Motor Modules with a Control Unit are part of the scope of supply of the relevant Cabinet Modules only if the control unit is mounted inside the respective Module (option K90 or K95), or if integration engineering is provided by the factory.

#### MOTION-CONNECT DRIVE-CLiQ cables

are used whenever components with DRIVE-CLiQ connections must meet high requirements such as mechanical stress and oil resistance, e.g. when connections are made outside the cabinet between

- Motor Modules and Sensor Modules
- Motor Modules and motors with DRIVE-CLiQ interface

MOTION-CONNECT DRIVE-CLiQ cables have 24 V DC cores

#### MOTION-CONNECT pre-assembled cables

are used whenever motor encoders on motors without DRIVE-CLiQ interface are connected to Sensor Modules.

Note: All 6FX.002-2C... signal cables are also available with crimped contacts and connector housing supplied as a separate accessory.

- Signal cables with connector (supplied as loose part) **for the motor end.** In this case, the 6th position of the Order No. must be changed from 0 to 4:  
6FX.042-2C...-....
- Signal cables with connector (supplied as loose part) **for the module end.** In this case, the 6th position of the Order No. must be changed from 0 to 1:  
6FX.012-2C...-....

### Integration

#### Connection overview for the CU320-2 Control Unit

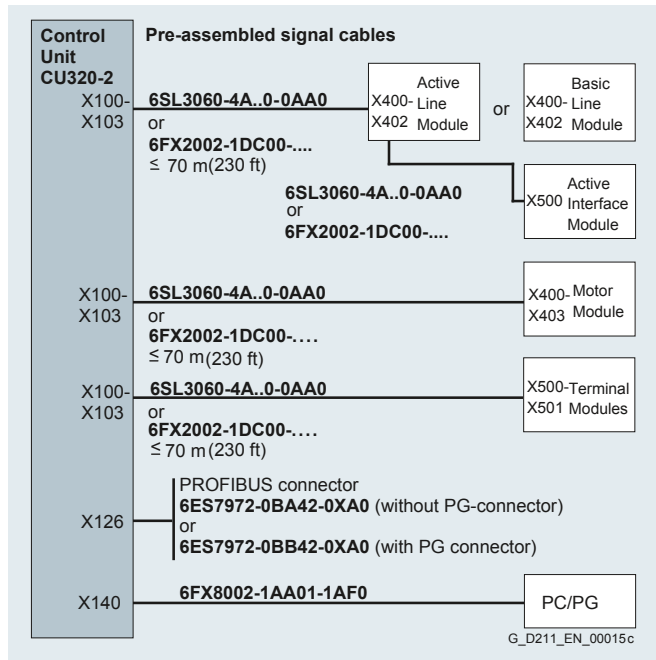

### Integration

#### Connection overview for Line Modules and Motor Modules

The DRIVE-CLiQ type 6SL3060-4A..0-0AA0 cables for the standard configuration are part of the scope of supply of the Line Modules and Motor Modules only if the control unit is mounted inside the respective Module (option K90 or K95), or if integration engineering is provided by the factory.

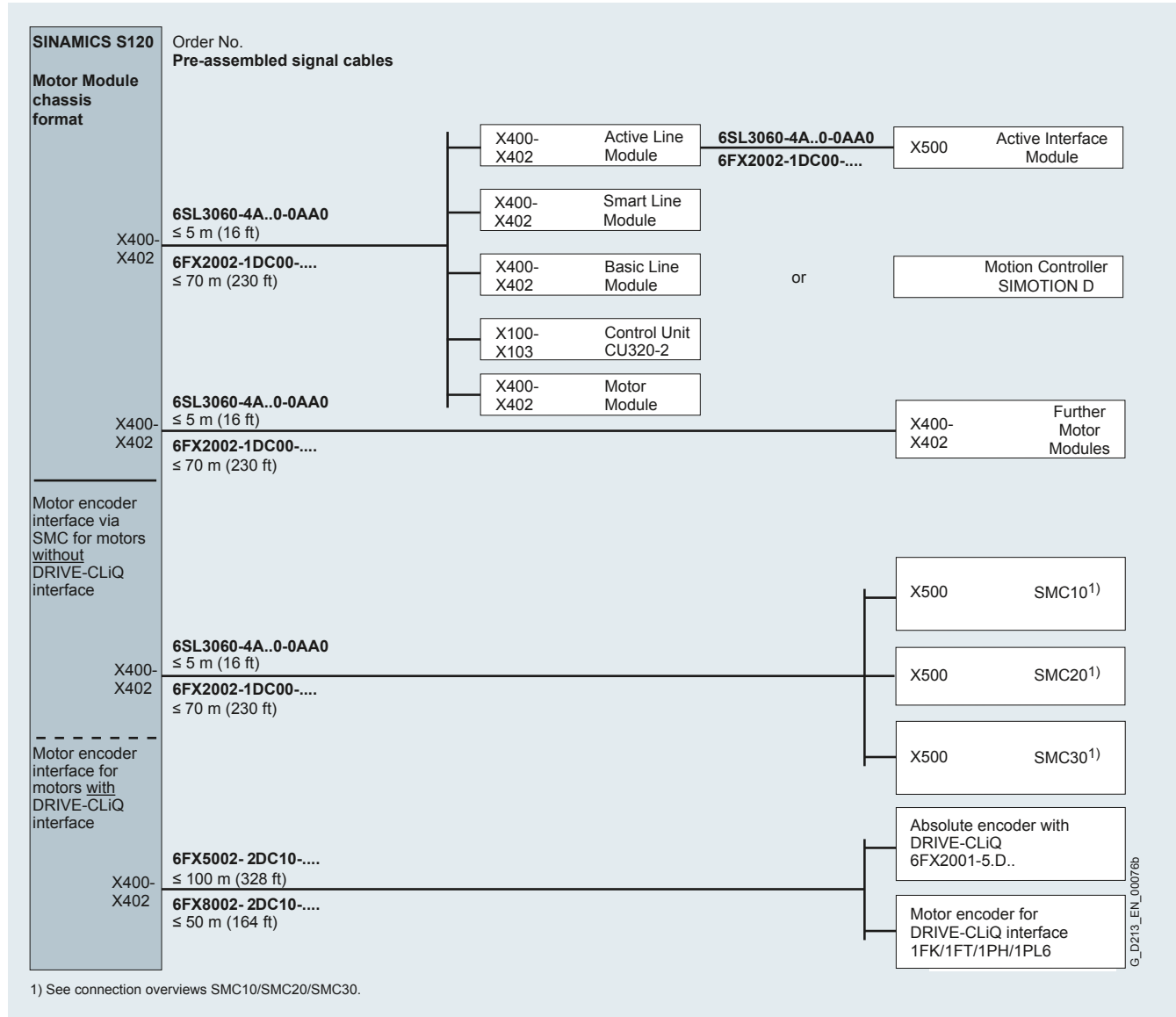

# SINAMICS S120 Cabinet Modules

## Connection system Signal cables

### Integration

#### Connection overview for connecting Sensor Modules to Line Modules and Motor Modules

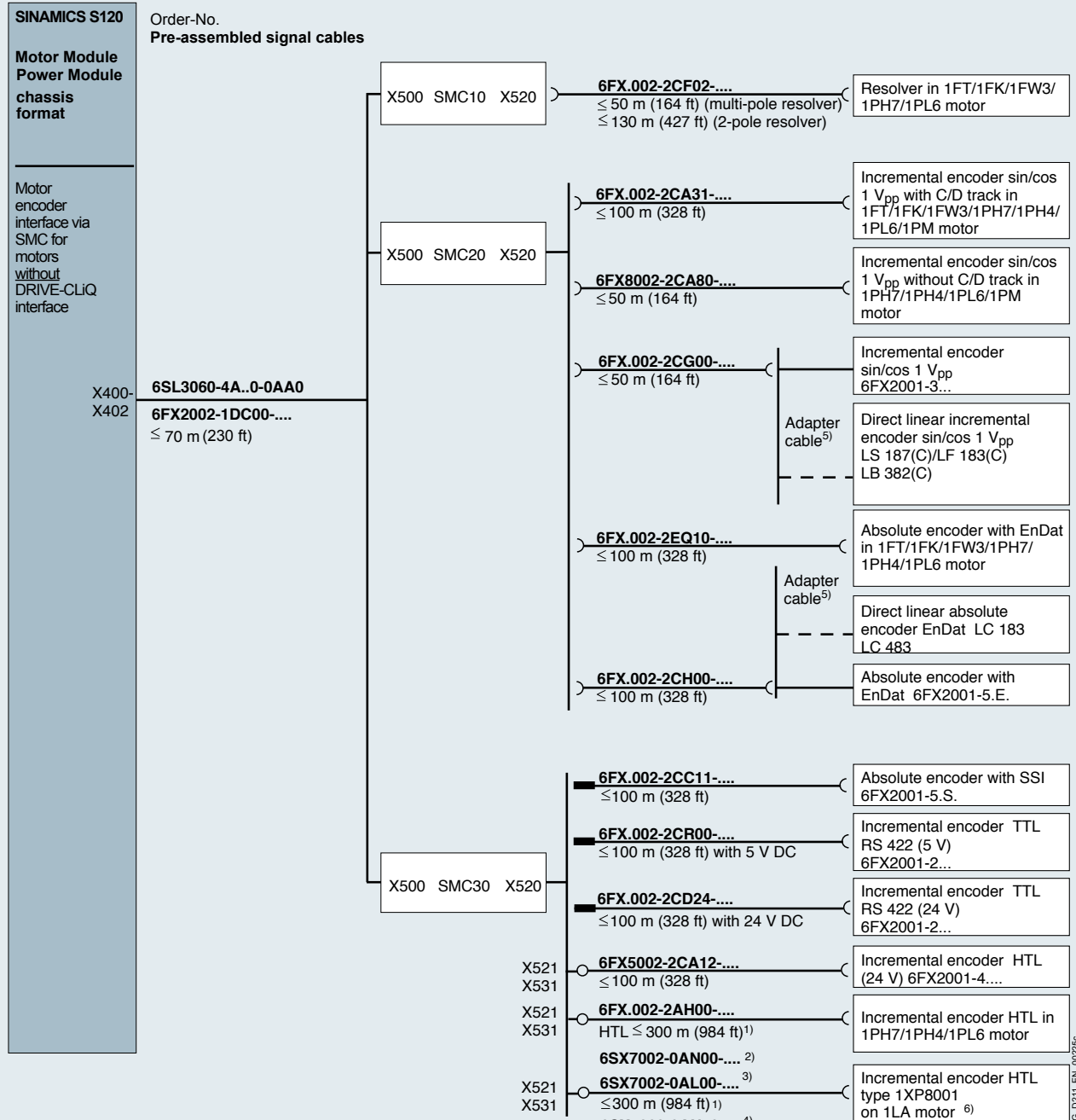

<sup>1)</sup> With evaluation of difference signals A\*, A and B\*, B, otherwise ≤ 100 m (328 ft).

<sup>2)</sup> Signals A\*, A, B\*, B, R\*, R.

<sup>3)</sup> Signals A, B.

<sup>4)</sup> With right-angled connector

<sup>5)</sup> Cable available from measuring system manufacturer.

<sup>6)</sup> Not for 2KG geared motor.

G\_D211\_EN\_0029c

### Integration

#### Connection of a machine encoder (direct measuring system)

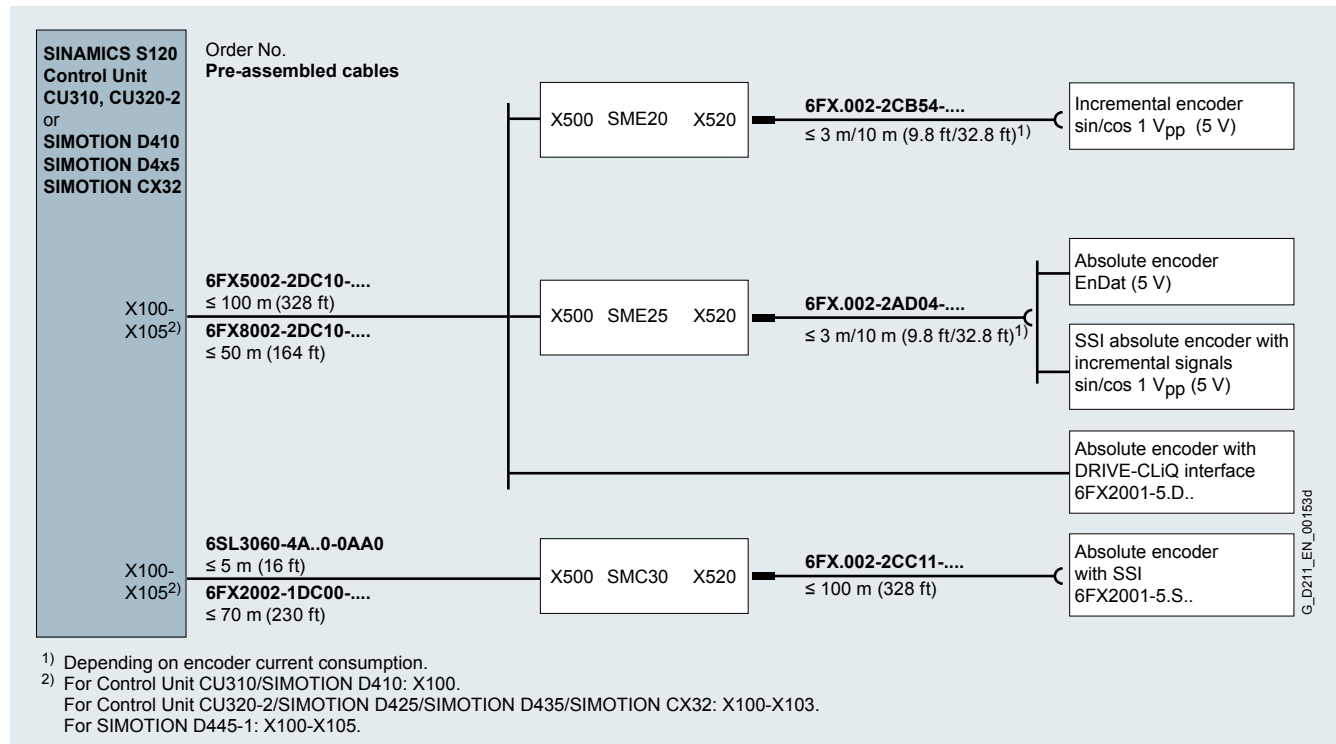

### Selection and ordering data

Signal cable	Length	Degree of protection (connector)	Basic cable Order No.
<b>DRIVE-CLiQ pre-assembled cables (without 24 V DC cores)</b>			
In specific lengths	0.11 m (4.3")	IP20/IP20	<b>6SL3060-4AB00-0AA0</b>
	0.16 m (6.3")		<b>6SL3060-4AD00-0AA0</b>
	0.21 m (8.3")		<b>6SL3060-4AF00-0AA0</b>
	0.26 m (10.2")		<b>6SL3060-4AH00-0AA0</b>
	0.31 m (12.2")		<b>6SL3060-4AK00-0AA0</b>
	0.36 m (14.2")		<b>6SL3060-4AM00-0AA0</b>
	0.41 m (16.1")		<b>6SL3060-4AP00-0AA0</b>
	0.60 m (23.6")		<b>6SL3060-4AU00-0AA0</b>
	0.95 m (37.4")		<b>6SL3060-4AA10-0AA0</b>
	1.20 m (47.2")		<b>6SL3060-4AW00-0AA0</b>
	1.45 m (57.1")		<b>6SL3060-4AF10-0AA0</b>
2.80 m (9.2 ft)	<b>6SL3060-4AJ20-0AA0</b>		
5.00 m (16.4 ft)	<b>6SL3060-4AA50-0AA0</b>		
To the meter	70 m (230 ft)	IP20/IP20	<b>6FX2002-1DC00-....</b>
	70 m (230 ft)	IP67/IP67	<b>6FX2002-1DC20-....</b>
<b>DRIVE-CLiQ MOTION-CONNECT 500 cables (with 24 V DC cores)</b>			
To the meter	100 m (328 ft)	IP20/IP20	<b>6FX5002-2DC00-....</b>
	100 m (328 ft)	IP20/IP67	<b>6FX5002-2DC10-....</b>
	100 m (328 ft)	IP67/IP67	<b>6FX5002-2DC20-....</b>
<b>DRIVE-CLiQ MOTION-CONNECT 800 cables (with 24 V DC cores)</b>			
To the meter	50 m (164 ft)	IP20/IP20	<b>6FX8002-2DC00-....</b>
	50 m (164 ft)	IP20/IP67	<b>6FX8002-2DC10-....</b>
	50 m (164 ft)	IP67/IP67	<b>6FX8002-2DC20-....</b>
Length code (refer to the next page) ....			

# SINAMICS S120 Cabinet Modules

## Connection system Signal cables

### Selection and ordering data

#### Length codes

Note: 1 m = 39.37" or 3.28 ft

Description	Order No. supplement				
Length codes for pre-assembled cables					
	6FX.....-.....-	<input type="checkbox"/>	<input type="checkbox"/>	<input type="checkbox"/>	<input type="checkbox"/>
	6SX.....-.....-	<input type="checkbox"/>	<input type="checkbox"/>	<input type="checkbox"/>	0
0 m	1				
100 m	2				
200 m	3				
300 m	4				
0 m		A			
10 m		B			
20 m		C			
30 m		D			
40 m		E			
50 m		F			
60 m		G			
70 m		H			
80 m		J			
90 m		K			
0 m			A		
1 m			B		
2 m			C		
3 m			D		
4 m			E		
5 m			F		
6 m			G		
7 m			H		
8 m			J		
9 m			K		
0 m					0
0.1 m					1
0.2 m					2
0.3 m					3
0.4 m					4
0.5 m					5
0.6 m					6
0.7 m					7
0.8 m					8
Examples:	1.0 m:	1	A	B	0
	2.2 m:	1	A	C	2
	8.0 m:	1	A	J	0
	299.0 m:	3	K	K	0

### Function

#### Safety Integrated functions

The integrated safety functions of SINAMICS provide highly effective application-oriented protection for personnel and machinery. The Safety Integrated functions are implemented electronically and therefore offer short response times in comparison to solutions with externally implemented monitoring functions.

The trend toward greater complexity and increasing modularity of machines is increasingly seeing a shift in safety functions away from the classical central safety functions (for example, shutdown of the complete machine using a main switch) and into the machine control system and the drives. Frequently, this also significantly increases the productivity. This is because, for instance, equipping times can be reduced and during these equipping times, depending on the machine type, other parts can still continue to produce.

Integrated safety functions act much faster than those of a conventional design. The safety of a machine is increased further with Safety Integrated. Furthermore, thanks to the faster method of operation, safety measures controlled by integrated safety systems are perceived as less of a hindrance by the machine operator, therefore significantly reducing the motivation to consciously bypass safety functions.

The safety functions in the device and communication via PROFIsafe have already been certified. This simplifies configuring the safety functions and especially the acceptance of the plant or system by an authorized testing body when compared to safety solutions made up of individual safety components.

#### Legal framework

Machine and plant builders must ensure that their machines or plants neither present risks due to electric shock, heat or radiation nor due to functional faults. In Europe, for example, compliance with the machinery directive is legally stipulated by the EU industrial safety directive.

In order to ensure compliance with this directive, it is recommended that the corresponding harmonized European standards are applied. This initiates the assumption of conformity and gives manufacturers and operators the legal security when complying with both national regulations and EU directives. The machine manufacturer uses the CE marking to document the compliance with all relevant directives and regulations in the free movement of goods.

#### Safety-related standards

Functional safety is specified in various standards. ISO 12100 and ISO 14121-1, for example, are concerned with the design and risk assessment of machines. IEC 62061 (only applicable for electrical and electronic control systems) and ISO 13849-1 (previously EN 954-1) define the functional and safety-related requirements of control systems with relevance to safety.

The above-mentioned standards define different safety requirements that the machine has to satisfy in accordance with the risk, frequency of a dangerous situation, probability of occurrence and the opportunities for recognizing impending danger.

- ISO 13849-1: Control Category 1...4
- ISO 13849-1: Performance Level PL a ... e
- IEC 62061: Safety Integrity Level SIL 1 ... 3

#### Safety functions integrated in the drive with SINAMICS

The safety functions integrated in SINAMICS satisfy the requirements of

- Control Category 3 according to ISO 13849-1
- Safety Integrity Level (SIL) 2 according to IEC 61508
- Performance Level (PL) d according to ISO 13849-1

In addition, the Safety Integrated functions of SINAMICS are generally certified by independent institutes. An up-to-date list of certified components is available on request from your local Siemens office.

### Function

#### Safety Basic Functions and Safety Extended Functions

The Safety Integrated functions of the SINAMICS drive system are subdivided into what are known as Safety Basic Functions and Safety Extended Functions (terminology according to IEC 61800-5-2):

#### • Basic Functions

- Safe Torque Off (STO)
- Safe Stop 1 (SS1, time-controlled)
- Safe Brake Control (SBC)

The Safety Basic functions are included in the standard scope of delivery of the drive firmware and can be used without requiring any additional license. The user can activate these functions at any time. An encoder is not required for their use. However, for the Safe Brake Control (SBC) function a Safe Brake Adapter (SBA) is required for chassis format Motor Modules.

The Safety Basic Functions are controlled as follows:

- Via terminals at the Control Unit and at the power unit, wired to a terminal interface in Cabinet Modules (option **K82**) and on the Safe Brake Adapter (option **K88**), when applicable.
- Via PROFIBUS or PROFINET with PROFIsafe profile (from version 3 (last position of the Order No.  $\geq 3$ ) and Drives SW Version V2.6 SP2)

#### • Extended Functions

- Safe Torque Off (STO)
- Safe Stop 1 (SS1, time-controlled and acceleration controlled)
- Safe Stop 2 (SS2)
- Safe Operating Stop (SOS)
- Safely-Limited Speed (SLS)
- Safe Speed Monitor (SSM)
- Safe Direction (SDI)

Safety Extended Functions require a safety license depending on the axes (options **K01** to **K05**). Depending on the control, additional DRIVE-CLiQ components are required.

Note: For chassis format Motor Modules, Extended Safety Functions require:

- either a sine-cosine encoder and therefore an SMC20 Sensor Module Cabinet-Mounted to evaluate the encoder signals (option **K48**).
- or two incremental encoders (TTL, HTL or SSI) and therefore two SMC30 Sensor Module Cabinet-Mounted to evaluate the encoder signals (options **K50+K52**).

The Safety Extended Functions are controlled as follows:

- Via the TM54F Terminal Module (option **K87**)
- Via PROFIBUS or PROFINET with the PROFIsafe profile

Extended Functions are available for SINAMICS S120 Motor Modules, booksize and chassis formats from version 3 (last position of the Order No.  $\geq 3$ ).

The Safety Integrated functions currently available in SINAMICS S120 are described in more detail below (terms as defined in IEC 61800-5-2):

#### Safe Torque Off (STO)

##### Function description

This function prevents unexpected starting according to EN 60204-1 Section 5.4. Safe Torque Off disables the control of the power unit, preventing a potentially hazardous torque (corresponds to Stop Category 0 according to EN 60204-1). The drive is reliably torque-free. This state is monitored internally in the drive.

Under Extended Functions, STO can also be controlled via the TM54F Terminal Module or PROFIsafe.

##### Application, customer benefits

STO has the immediate effect that the drive cannot supply any torque-generating energy. STO can be used wherever the drive will naturally reach a standstill due to load torque or friction in a sufficiently short time or when "coasting down" of the drive will not have any relevance for safety.

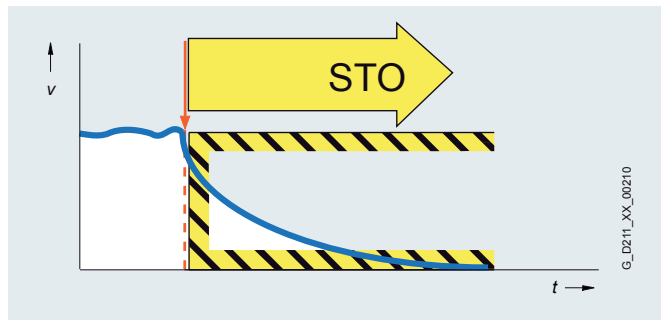



## Function

### Safe Brake Control (SBC)

#### Function description

The Safe Brake Control SBC is used to control holding brakes, which are active in the no-current state, e.g. motor holding brakes (actuated using spring force). The brake is controlled through two channels in a safety-relevant fashion.

Safe Brake Control is executed when activating the operational brake control, Safe Torque Off function and when safety monitoring functions respond, which cause the power unit to be safely inhibited.

- **Note 1:** The Safe Brake Control does not detect mechanical faults in the brake, for example worn brake pads.
- **Note 2:** For Motor Modules, Booksize Cabinet Kits format, the terminals for the motor brake are integrated. For the chassis format, an additional Safe Brake Adapter (SBA) is required (option **K88**, for a description see pg. 6/37).

#### Application, customer benefits

In conjunction with STO and SS1, SBC can also be activated. After switching off the torque-generating energy, SBC offers the possibility to safely control a holding brake at the motor; for example, to prevent hanging/suspended axes from sagging.

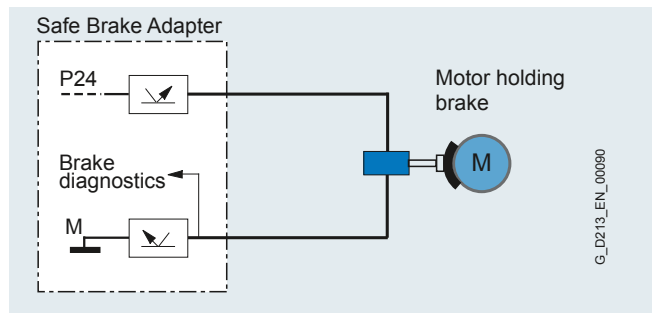

### Safe Stop 1 (SS1, time-controlled, without encoder; Basic Safety Function)

#### Function description

The Safe Stop 1 function can safely stop the drive in accordance with EN 60204-1, Stop Category 1. When the SS1 function is selected, the drive independently brakes along a quick stop ramp (OFF3) and Safe Torque Off and Safe Brake Control (if enabled) are activated when the selected safety delay time has expired.

#### Application, customer benefits

When activating the stop function, if the drive train does not come quickly enough to a standstill as a result of the load torque, then it can be actively braked by the drive. As a result of this integrated fast brake function, frequently it is possible to eliminate mechanical brakes which wear, or to reduce the load on them. This means that maintenance costs and stress on the machine can be reduced.

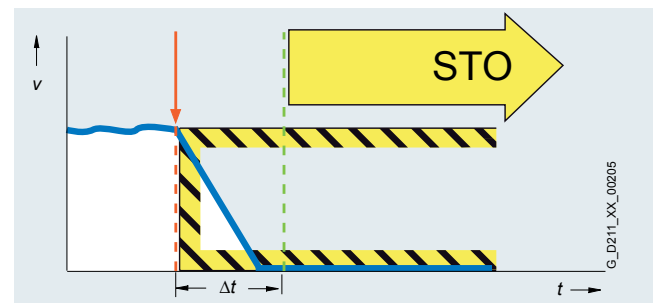

### Safe Stop 1 (SS1, time and acceleration controlled, with sine-cosine encoder; Extended Safety Function)

#### Function description

The Safe Stop 1 function can safely stop the drive in accordance with EN 60204-1, Stop Category 1. When the SS1 function is selected, the drive independently brakes along a quick stop ramp, the deceleration is monitored (OFF3) and Safe Torque Off and Safe Brake Control (if enabled) are automatically activated when the selected safety delay time has expired.

#### Application, customer benefits

When activating the stop function, if the drive train does not come quickly enough to a standstill as a result of the load torque, then it can be actively braked by the drive. As a result of this integrated fast brake function, frequently it is possible to eliminate mechanical brakes which wear, or to reduce the load on them. This means that maintenance costs and stress on the machine can be reduced.

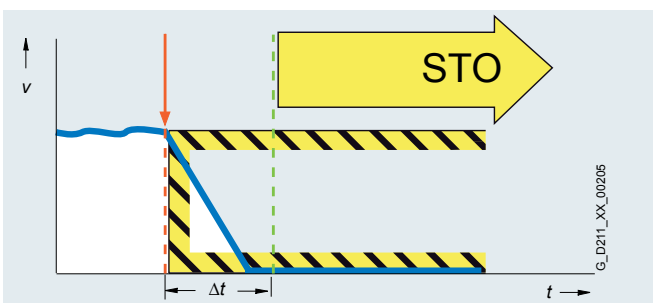

## Safety integrated

### Function

#### Safe Stop 2 (SS2, with sine-cosine encoder)

##### Function description

The Safe Stop 2 function can safely stop the drive in accordance with EN 60204-1, Stop Category 2. When the SS2 function is selected, the drive brakes autonomously along a quick stop ramp (OFF3). In contrast to SS1, the drive control remains operational afterwards, i.e. the motor can supply the full torque required to maintain the actual position. Standstill is safely monitored (Safe Operating Stop function, SOS).

##### Application, customer benefits

Just the same as for SS1, the drive is independently braked when the stop function is selected. Contrary to SS1, also at standstill, the drive can provide the full torque.

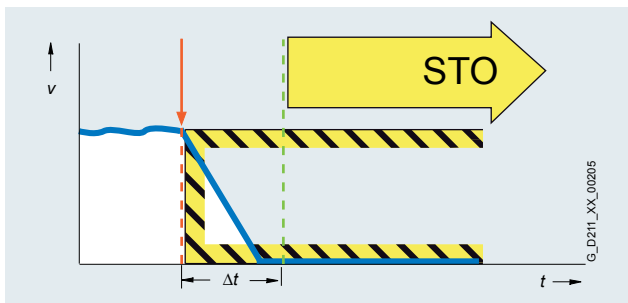

#### Safe Stop 1 (SS1) and Safe Stop 2 (SS2) with Safe Acceleration Monitor (SAM, with sine-cosine encoder)

For the Extended Functions Safe Stop 1 (SS1) and Safe Stop 2 (SS2) with SAM, during braking, the acceleration is safely monitored (SAM) in order to identify faults already during the braking phase. Safe Operating Stop (SOS, with sine-cosine encoder)

#### Safe Operating Stop 1 (SOS), with sine-cosine encoder

##### Function description

The Safe Operating Stop function constitutes safe standstill monitoring. The drive control remains in operation. The motor can therefore deliver the full torque to hold the current position. The actual position is reliably monitored. In contrast to safety functions SS1 and SS2, the speed setpoint is not influenced autonomously. After SOS has been selected, the higher-level control must bring the drive to a standstill within a parameterized safe time  $\Delta t$  and then hold the position setpoint. After the time  $\Delta t$  has expired, SOS is activated and monitored to ensure that the actual standstill position is not left.

##### Application, customer benefits

SOS is the ideal function for all those applications for which the machine or parts of the machine must be at a safe standstill for certain machining steps, but where the drive must also supply a holding torque.

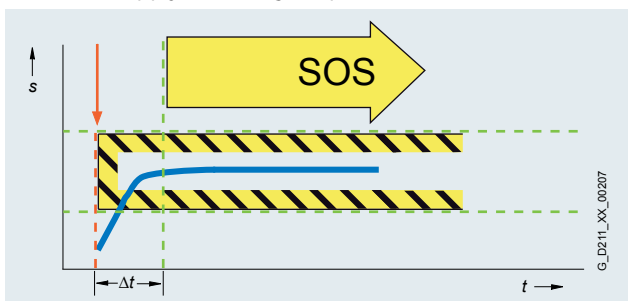

#### Safely-Limited Speed (SLS, with sine-cosine encoder)

##### Function description

Using the Safely-Limited Speed function, the drive is monitored against a parameterizable maximum velocity. Four different limit values can be activated. Just the same as for SOS, the speed setpoint is not independently influenced. After SLS has been selected, the higher-level control must bring the drive to below the selected velocity limit within a parameterizable time  $\Delta t$ .

##### Application, customer benefits

When setting-up many machines operating personnel must work on the machine as it rotates. This must either be done in steps, because the dangerous area must always be exited at each start, or alternatively, the operator works at the machine while it moves and is therefore exposed to an increased risk. When using the SLS function, a considerable amount of time can be saved – and it is still guaranteed that the operating personnel are safe. For this purpose, the drive velocity can be safely limited to a safe low level. The selectable wait time until SLS is activated allows the drive control to run-down the coordinated axes in a controlled fashion.

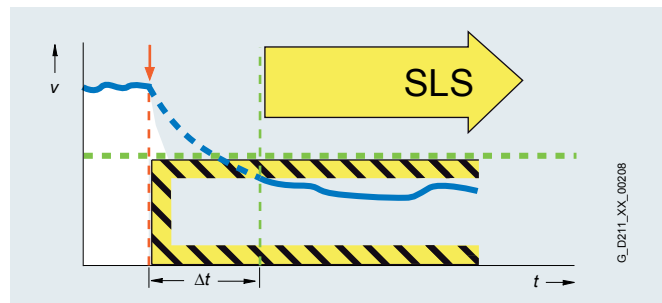

#### Safe Speed Monitor (SSM, with sine-cosine encoder)

##### Function description

The Safe Speed Monitor function supplies a safety feedback signal (high active) if the drive falls below a selectable velocity limit value. Contrary to the functions described above, there is no drive-based fault response when the limit value is exceeded.

##### Application, customer benefits

The safety SSM feedback signal can be used in a higher-level control for safety-relevant responses. The higher-level safety control can flexibly respond to the signal, depending on the particular situation, as there is no drive-based response when the limit value is exceeded. For example, using the SSM signal, a protective door can be released after a non-hazardous velocity is reached.

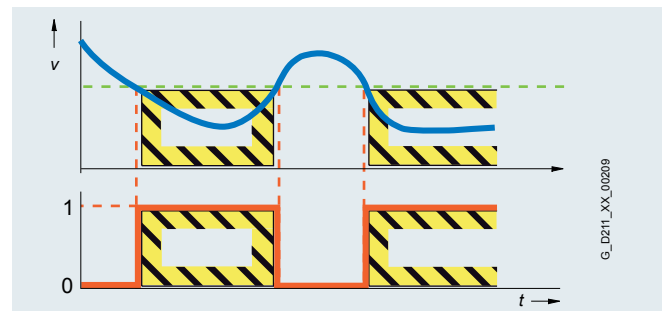

## Function

### Safe Direction (SDI, with sine-cosine encoder)

#### Function description

The SDI function ensures that the drive can only rotate in the selected direction.

Deviation from the direction of rotation currently being monitored is detected reliably and the configured drive-integrated fault reaction is initiated. It is possible to select which direction of rotation is to be monitored.

#### Application, customer benefits

The SDI function is used when the drive may only move in one direction. A typical application is to permit the operator access to a danger zone, as long as the machine is rotating in the safe direction, i.e. away from the operator. In this state, the operator can feed material into the work zone/remove material from the work zone without danger.

The function saves the use of external components e.g. speed monitors and the associated wiring. The release of a danger zone, while the machine is moving away from the operator, increases productivity. Without the SDI function, the machine must be safely stopped during material loading and removal.

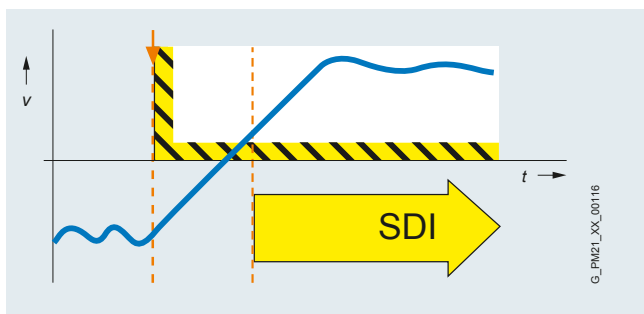

### PROFIsafe

PROFIsafe is an open communication standard, that facilitates standard and safety-relevant communication along one communication path (hard-wired or wireless). As a consequence, a second, separate bus system is not required. The telegrams that are sent are continually monitored to ensure safety-relevant communication. Possible errors such as telegrams that have been lost, repeated or received in the incorrect sequence etc. are avoided. This is done by consecutively numbering the telegrams in a safety-relevant fashion, monitoring their reception within a defined time and transferring an ID for transmitter and receiver of a telegram. Further, a cyclic redundancy check CRC (cyclic redundancy check) is performed.

SINAMICS 120 supports the PROFIsafe profile, based on PROFIBUS as well as on PROFINET.

### Licensing

The Safety Integrated Basic Functions do not require a license.

A license is, however, required for each axis with safety functions in the case of Safety Integrated Extended Functions. It is irrelevant which safety functions are used and how many.

Licenses required for SINAMICS S120 Cabinet Modules can be ordered, depending on the axes, with safety options **K01** to **K05** for Motor Modules.

# SINAMICS S120 Cabinet Modules

## Safety integrated

### Function

An overview of the SINAMICS Safety Integrated functions plus their boundary conditions is provided in the following table.

Function	Control	Underlying function	Reaction to limit overshoot	Encoder required	License required
<b>Safety Basic Functions</b>					
<b>STO</b>	<ul style="list-style-type: none"> <li>EP terminals on the power unit and digital input at the CU3xx/D4xx/CX32</li> <li>PROFIsafe</li> <li>Terminal module (24 V to 230 V), option <b>K82</b><sup>1)</sup></li> </ul>	SBC (if activated)	–	No	No
<b>SS1</b>	<ul style="list-style-type: none"> <li>EP terminals on the power unit and digital input at the CU3xx/D4xx/CX32</li> <li>PROFIsafe</li> <li>Terminal module (24 V to 230 V), option <b>K82</b><sup>1)</sup></li> </ul>	STO, after a parameterized delay time has expired	STO	No	No
<b>SBC</b>	<ul style="list-style-type: none"> <li>Via Safe Brake Adapter<sup>2)</sup></li> </ul>	–	–	No	No
<b>Safety Extended Functions</b>					
<b>STO</b>	<ul style="list-style-type: none"> <li>Terminals on the TM54F<sup>3)</sup></li> <li>PROFIsafe</li> </ul>	SBC (if activated)	–	Yes <sup>4)</sup>	Yes (each safety axis)
<b>SS1</b>	<ul style="list-style-type: none"> <li>Terminals on the TM54F<sup>3)</sup></li> <li>PROFIsafe</li> </ul>	STO is activated after the shutdown conditions have been fulfilled	STO	Yes <sup>4)</sup>	Yes (each safety axis)
<b>SBC</b>	<ul style="list-style-type: none"> <li>Via Safe Brake Adapter</li> </ul>	–	–	Yes <sup>4)</sup>	Yes (each safety axis)
<b>SS2</b>	<ul style="list-style-type: none"> <li>Terminals on the TM54F<sup>3)</sup></li> </ul>	STO is activated after the shutdown conditions have been fulfilled	STO	Yes <sup>4)</sup>	Yes (each safety axis)
<b>SLS</b>	<ul style="list-style-type: none"> <li>Terminals on the TM54F<sup>3)</sup></li> <li>PROFIsafe</li> </ul>	Up to four maximum speeds for operation can be parameterized	STO, SS1 or SOS (can be parameterized)	Yes <sup>4)</sup>	Yes (each safety axis)
<b>SOS</b>	<ul style="list-style-type: none"> <li>Terminals on the TM54F<sup>3)</sup></li> <li>PROFIsafe</li> </ul>	For closed-loop speed control: The position is monitored from standstill	STO or SS1 (can be parameterized)	Yes <sup>4)</sup>	Yes (each safety axis)
<b>SSM</b>	<ul style="list-style-type: none"> <li>Terminals on the TM54F<sup>3)</sup></li> <li>PROFIsafe</li> </ul>	Safe limit value monitoring in both directions of rotation, no independent drive response. A safety-relevant signal for further operation is generated.	–	Yes <sup>4)</sup>	Yes (each safety axis)
<b>SDI</b>	<ul style="list-style-type: none"> <li>Terminals on the TM54F<sup>3)</sup></li> <li>PROFIsafe</li> </ul>	–	STO, SS1 or SOS (can be parameterized)	Yes <sup>4)</sup>	Yes (each safety axis)

1) In addition for SINAMICS S120 Cabinet Modules.

2) Safe Brake Adapter has been released from firmware version 4.4.

3) For SINAMICS S120 Cabinet Modules as option **K87**.

4) The Safety Integrated Extended Functions require either a sine-cosine encoder or two incremental encoders to sense the motor speed. Possible encoder evaluation units units SMC20, SMI20, SME20/25/120/125 or SMC30.

### Function

#### The principle of operation of Safety Integrated

##### Two independent shutdown paths

There are two shutdown paths that are independent of one another.

All shutdown paths are low active. This therefore ensures that when a component fails or there is a wire break, then the system always goes into the safe state. When a fault is detected in the shutdown paths, the Safe Torque Off or Safe Stop 1 function (depending on the parameterization, also refer to the table on the Page 3/13) is activated and a restart is prevented.

##### Two-channel monitoring structure

All of the hardware and software functions important for Safety Integrated are implemented in two independent monitoring channels (e.g. shutdown paths, data management, data comparison). The safety-relevant data in the two monitoring channels is cyclically compared crosswise.

The monitoring functions in each monitoring channel are based on the principle that before a particular action, there must be a defined state, and after the action there must be a specific feedback. If this expectation is not fulfilled in a monitoring channel, then the drive is shutdown through two channels and the appropriate signal output.

##### Forced checking procedure using a test stop

In order to fulfill the requirements of ISO 13849-1 (previously EN 954-1) and IEC 61508 regarding early fault detection, the functions and the shutdown paths must be tested within a specific time period at least once to ensure that they are operating correctly. This must be realized either cyclically and manually or the test stop must be automatically initiated as part of the process.

The test stop cycle is monitored, and after a specific time has been exceeded, an alarm is output.

A test stop does not require a power on. The acknowledgment is realized when deselecting the test stop request. When the machine is operational, it can be assumed that there is no risk for personnel as a result of the appropriate safety equipment (e.g. protective doors). As a consequence, the user is only made aware of the forced checking procedure that is required using an alarm, and is requested to perform the forced checking procedure at the next possible opportunity.

Examples for performing the forced checking procedure:

- When the drives are stationary after switching-on the system
- Before opening the protective door
- In a specified rhythm (e.g. every 8 hours)
- In the automatic mode, time and event-triggered

## TM54F Terminal Module

### Overview



The TM54F Terminal Module (**option K87**) is a dual-processor I/O interface with 4 fail-safe digital outputs and 10 fail-safe digital inputs for using Safety Integrated functions of the SINAMICS S120 drive system via external actuators and sensors.

All of the available safety functions integrated in the drive can be controlled via the fail-safe digital inputs of the TM54F Terminal Module. For the case that the parameterized safety functions of several drives operated together on a CU320-2 or SIMOTION D4x5 are to be executed together, then these drives can be grouped in the TM54F Terminal Module. This has the advantage that only one fail-safe digital input has to be connected for these drives.

The fail-safe digital outputs and inputs have two channels with an internal crosswise data comparison via the two processors. A fail-safe digital output consists of one P-switching and one M-switching output as well as one digital input to read back the switching state. A fail-safe digital input consists of two digital inputs.

Safety sensors can be connected over two switchable 24 V sensor supplies and evaluated via the fail-safe digital inputs. The switchable 24 V sensor supply ensures that the fail-safe digital inputs can be dynamized to detect dormant errors (this dynamization is used to check the shutdown paths). A non-switchable 24 V sensor supply is additionally provided by the TM54F Terminal Module for connecting safety sensors that cannot be dynamized.

The TM54F Terminal Module is connected directly to a Control Unit via DRIVE-CLiQ. Each Control Unit can only be assigned to one TM54F Terminal Module.

Additional DRIVE-CLiQ nodes such as Sensor Modules and Terminal Modules (however no additional TM54F Terminal Module) can be operated on the TM54F Terminal Module. Motor Modules and Line Modules must not be connected to a TM54F Terminal Module.

### Design

The following are located on the TM54F Terminal Module:

- 4 fail-safe digital outputs
- 10 fail-safe digital inputs
- 4 LEDs, single color for indicating the status of the read back channel of the fail-safe digital outputs
- 4 LEDs, dual-color for indicating the status of the fail-safe digital outputs
- 20 LEDs, dual-color for indicating the status of the fail-safe digital inputs
- 3 LEDs, single color for indicating the status of the 24 V sensor supplies
- 2 connections for 24 V sensor supply, switchable
- 1 connection for 24 V sensor supply, non-switchable

The signal cable shield can be connected to the TM54F Terminal Module via a shield connection terminal, e.g. Phoenix Contact type SK8 or Weidmüller type KLBÜ CO 1. The shield connection terminal must not be used for strain relief.

The status of the TM54F Terminal Module is indicated via a multicolor LED.

Pins for connector coding are included in the TM54F Terminal Module scope of delivery.

### Technical data

TM54F Terminal Module		TM54F Terminal Module	
<b>Current demand</b> (X524 at 24 V DC) without DRIVE-CLiQ supply	0.2 A	<b>Scanning cycle <math>t_{SI}</math></b> for fail-safe digital inputs or fail-safe digital outputs	4 ... 25 ms (adjustable)
<b>Max. current demand ext. 24 V</b> or supplying the digital outputs and 24 V sensor supply (X514 at 24 V DC)	4 A	<b>Conformity</b>	CE
<b>I/O devices</b>		<b>Approvals, according to</b>	cULus
<ul style="list-style-type: none"> <li>Number of fail-safe digital inputs</li> <li>Number of fail-safe digital outputs</li> <li>24 V sensor supply</li> </ul>	10 4 3, of which 2 can be internally shut down to dynamize fail-safe digital inputs, current carrying capacity of input is 0.5 A	<b>Safety Integrated</b>	Safety Integrity Level 2 (SIL2) acc. to IEC 61508, Performance Level d (PLd) acc. to ISO 13849-1 and Control Category 3 acc. to ISO 13849-1 (previously EN 954-1)
<ul style="list-style-type: none"> <li>Connection system</li> <li>Wire size, max.</li> </ul>	Plug-in screw-type terminals #14 AWG (1.5 mm <sup>2</sup> )		
<b>Digital inputs</b> According to IEC 61131-2 Type 1, with electrical isolation			
<ul style="list-style-type: none"> <li>Voltage</li> <li>Low level (an open digital input is interpreted as "low")</li> <li>High level</li> <li>Current consumption at 24V DC, typ.</li> <li>Delay time of digital inputs, approx 1) - L → H, typ.</li> <li>- H → L, typ.</li> <li>Safe state</li> </ul>	-3 ... +30 V -3 ... +5 V 15 ... 30 V >2 mA 30 μs 60 μs Low level (for inputs that can be inverted: without inversion)		
<b>Digital outputs</b> Continuously short-circuit proof			
<ul style="list-style-type: none"> <li>Voltage</li> <li>Load current per fail-safe digital output max. 2)</li> <li>Delay times (resistive load) 1) - L → H, typ.</li> <li>- H → L, typ.</li> <li>Safe state</li> </ul>	24 V DC 0.5 A 300 μs 350 μs Output switched off		

1) The specified delay times refer to the hardware. The actual reaction time depends on the time slot in which the digital input/output is processed.

2) The total current of all fail-safe digital outputs must not exceed 5.33 A.

# SINAMICS S120 Cabinet Modules

## Safe Brake Adapter SBA

### Overview



A Safe Brake Adapter SBA is required to safely control a motor holding brake via the Safe Brake Control (SBC) safety function according to IEC 61800-5-2.

The Safe Brake Adapter is available for 230 V AC brake control voltages.

It is available as option **K88** or SINAMICS S120 Cabinet Modules.

**Note:** The SBA approval is currently only valid for IEC regions. The SBA is not yet UL listed and may not be included in a UL listed Cabinet Module line-up.

Safe Brake Adapter	Option K88
Supply voltage of the motor holding brake	230 V AC
Max. permissible current consumption of the	
• Motor holding brake	2 A
• Fast de-energization	2 A
Max. permissible cable lengths	
• to the brake	990 ft (300 m)
Max. wire size	#12 AWG (2.5 mm <sup>2</sup> )
Safety Integrated	Safety Integrity Level 2 (SIL2) acc. to IEC 61508, Performance Level d (PLd) acc. to ISO 13849-1 and Control Category 3 acc. to ISO 13849-1 (previously EN 954-1)

### Integration

The SBC function is controlled and monitored by the SINAMICS Drives firmware. The control and feedback signal regarding the switching state of the SBA relay is realized via terminals of the Control Interface Module (CIM). The excitation coil of the holding brake is connected directly at the SBA.





7/2

## Engineering software

SIZER for Siemens drives  
STARTER commissioning tool  
Drive Control Chart

7/6

## Service & Support

Service tool for exchanging power blocks  
Spare parts  
Complete lifecycle services  
Service & Support contacts

## Engineering software

### SIZER for Siemens Drives engineering tool

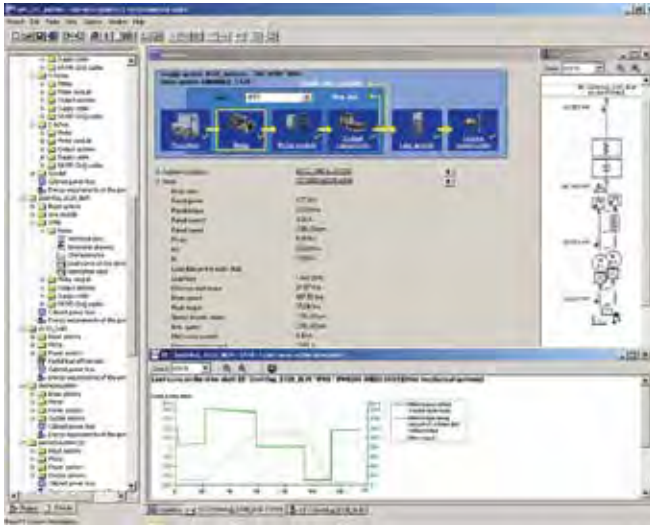

The following drives and controls can be engineered in a user-friendly way using the SIZER for Siemens Drives engineering tool:

- SINAMICS Low Voltage, MICROMASTER 4, DYNAVERT T, SIMATIC ET 200S FC and SIMATIC ET 200pro FC drive systems
- Motor starters
- SINUMERIK CNC control
- SIMOTION Motion Control System
- SIMATIC Technology

It provides support when setting up the technologies involved in the hardware and firmware components required for a drive task. SIZER for Siemens Drives covers the full range of operations required to configure a complete drive system, from simple single drives to complex multi-axis applications.

SIZER for Siemens Drives supports all of the configuring steps in a workflow:

- Configuring the power supply
- Selecting the motor and gearbox, including calculation of mechanical transmission elements
- Configuring the drive components
- Compiling the required accessories
- Selecting the line-side and motor-side power options, e.g., cables, filters, and reactors

When SIZER for Siemens Drives was being designed, particular importance was placed on a high degree of usability and a universal, function-based approach to the drive application. The extensive user guidance makes using the tool easy. Status information keeps you continually informed about the progress of the configuration process.

The SIZER for Siemens Drives user interface is available in German, English, French and Italian.

The drive configuration is saved in a project. In the project, the components and functions used are displayed in a hierarchical tree structure.

The project view permits the configuration of drive systems and the copying/inserting/modifying of drives already configured.

The configuration process produces the following results:

- A parts list of the required components (export to Excel, use of the Excel data sheet for import to SAP)
- Technical specifications of the system
- Characteristic curves
- Comments on system reactions
- Mounting arrangement of drive and control components and dimension drawings of motors
- Energy requirements of the configured application

These results are displayed in a results tree and can be reused for documentation purposes.

Technological online help is available:

- Detailed technical specifications
- Information about the drive systems and their components
- Decision-making criteria for the selection of components
- Online help in German, English, French, Italian, Chinese and Japanese

#### System requirements

- PG or PC with Pentium III min. 800 MHz (recommended > 1 GHz)
- 512 MB RAM (1 GB RAM recommended)
- At least 4.1 GB of free hard disk space
- An additional 100 MB of free hard disk space on the Windows system drive
- Screen resolution 1024 × 768 pixels (recommended 1280 × 1024 pixels)
- Operating system
  - Windows XP Home Edition SP2
  - Windows XP Professional 32 bit SP2
  - Windows XP Professional 64 bit SP2
  - Windows Vista Business
  - Windows 7 Ultimate 32 bit
  - Windows 7 Professional 32 bit
- Microsoft Internet Explorer 5.5 SP2

#### Selection and ordering data

	Order No.
SIZER for Siemens Drives engineering tool DVD-ROM German, English, French, Italian	6SL3070-0AA00-0AG0

#### More information

The SIZER for Siemens Drives engineering tool is available free on the Internet at:

[www.siemens.com/sizer](http://www.siemens.com/sizer)

## STARTER commissioning tool

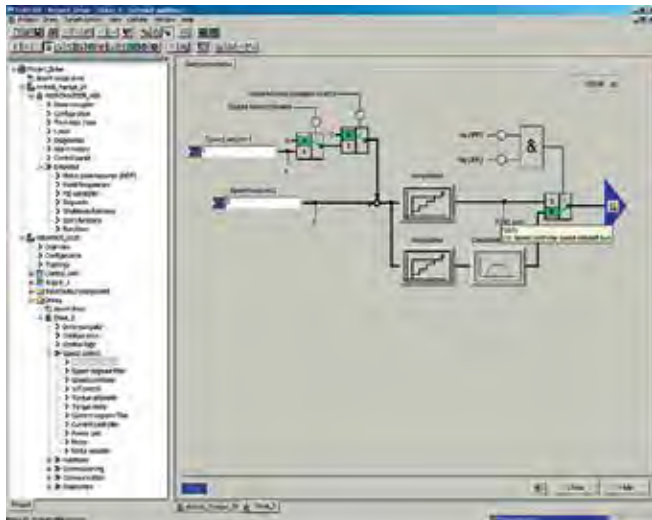

The user-friendly STARTER commissioning tool can be used for

- Commissioning
- Optimization
- Diagnostics

This software can be operated either as a standalone PC application, integrated in SIMATIC STEP 7 with TIA compatibility via Drive ES Basic, or it can be integrated into the SCOUT engineering system (for SIMOTION). The basic functions and handling are the same in both cases.

Configuring can be realized both offline as well as online. If several drives are connected to the selected communication bus, then an online connection can be established to several drives simultaneously.

The project wizards can be used to create the drives within the structure of the project tree.

Beginners are supported by solution-based dialog guidance, whereby a standard graphics-based display maximizes clarity when setting the drive parameters.

First commissioning is guided by a wizard which makes all the basic settings in the drive. Therefore, getting a motor up and running is merely a question of setting a few of the drive parameters as part of the drive configuration process.

The travel commands can be simply entered via the control panel from the PC.

The individual settings can be made using the graphic parameterizing screen forms, which precisely visualize the drive mode of operation.

Examples of individual settings that can be made include:

- How terminals are used
- Bus interface
- Setpoint channel (e.g., fixed setpoints)
- Closed-loop speed control (e.g., ramp-function generator, limits)
- BICO interconnections
- Diagnostics

For experts, the expert list can be used to specifically and quickly access individual parameters at any time. An individual compilation of frequently used parameters can be saved in dedicated user lists and watch tables.

In addition, the following functions are available for optimization purposes:

- Self-optimization of the controller settings (depending on the drive unit)
- Trace to precisely record the signals (this depends on the drive unit, is not supported for
  - MICROMASTER 4
  - SINAMICS G110
  - SINAMICS G120 < FW V4.4
  - SINAMICS G110D
  - SINAMICS G120D
  - SIMATIC ET 200S FC
  - SIMATIC ET 200pro FC)
- Numerous measuring functions such as step functions and frequency response analysis

Diagnostics functions provide information about:

- Control/status words
- Parameter status
- Conditions of use
- Communication states

### Performance features

- User-friendly: Only a small number of settings need to be made for successful first commissioning: The motor starts to rotate
- Solution-oriented dialog-based user guidance simplifies commissioning
- Self-optimization functions reduce manual optimization work.

### System requirements V4.2 and higher

- PG or PC Pentium III min. 1 GHz (recommended > 1 GHz)
- 1 GB RAM (recommended 2 GB RAM)
- Screen resolution 1024 x 768 pixels, 16 bit color depth
- Free hard disk memory min. 3 GB
- Software
  - Microsoft Internet Explorer V6.0 or higher
  - 32 bit operating systems:
    - Microsoft Windows Server 2003 SP2
    - Microsoft Windows Server 2008
    - Microsoft Windows XP Professional SP3
    - Microsoft Windows 7 Professional incl. SP1
    - Microsoft Windows 7 Ultimate incl. SP1
    - Microsoft Windows 7 Enterprise incl. SP1 (Standard Installation)
  - 64 bit operating systems:
    - Microsoft Windows 7 Professional SP1
    - Microsoft Windows 7 Ultimate SP1
    - Microsoft Windows 7 Enterprise SP1 (Standard Installation)
    - Microsoft Windows Server 2008 R2

## Engineering software

### Integration

The fieldbus communication between the Control Units of SINAMICS S120, SINAMICS S150, SINAMICS G130 and SINAMICS G150 can, depending on the CU version (DP or PN), be realized via PROFIBUS or PROFINET/Ethernet, alternatively, also via the serial RS232 interface.

Further, there is the option of coupling SINAMICS S120, SINAMICS S150, SINAMICS G130, SINAMICS G150 and SINAMICS DC MASTER via SINAMICS Link, e.g. to establish a setpoint cascade.

For commissioning and service, a PG/PC can be connected to the CU320-2 Control Unit via PROFIBUS. A PROFIBUS connection must be available with a connecting cable at the PG/PC.

Further, communication between a CU320-2 Control Unit and PG/PC can also be established via Ethernet, either via an (optional) CBE20 Communication Board or the Ethernet interface -X127 on the CU320-2 Control Unit.

Note on -X127:

This terminal block is only intended for communication between a PG/PC for service and commissioning.

### Selection and ordering data

	Order No.
<b>STARTER commissioning tool</b> For SINAMICS and MICROMASTER on DVD-ROM German, English, French, Italian, Spanish	<b>6SL3072-0AA00-0AG0</b>
<b>Accessories</b>	
<b>SIMATIC S7 connecting cable</b> RS232 null modem cable, 6 m	<b>6ES7901-1BF00-0XA0</b>
<b>PROFIBUS communication module CP 5512</b> PCMCIA type 2 card + adapter with 9-pin SUB-D socket, for Windows 2000/Windows XP Professional and PCMCIA 32	<b>6GK1551-2AA00</b>
<b>SIMATIC DP plug-in cable</b> 12 Mbit/s, for PG connection, pre-assembled with 2 × 9-pin SUB-D connector, 3 m	<b>6ES7901-4BD00-0XA0</b>
<b>PROFINET/Ethernet</b> Standard-CAT5 Ethernet cable or PROFINET cable	

### More information

The STARTER commissioning tool is also available for update purposes on the Internet at [www.siemens.com/starter](http://www.siemens.com/starter)

### Drive Control Chart (DCC)

Drive Control Chart (DCC) expands the scope of device functions by means of freely available closed-loop control, calculation and logic modules and offers a means by which technological functions can be graphically configured in the SINAMICS S120 drive system. DCC is installed as an additional application to the STARTER commissioning tool.

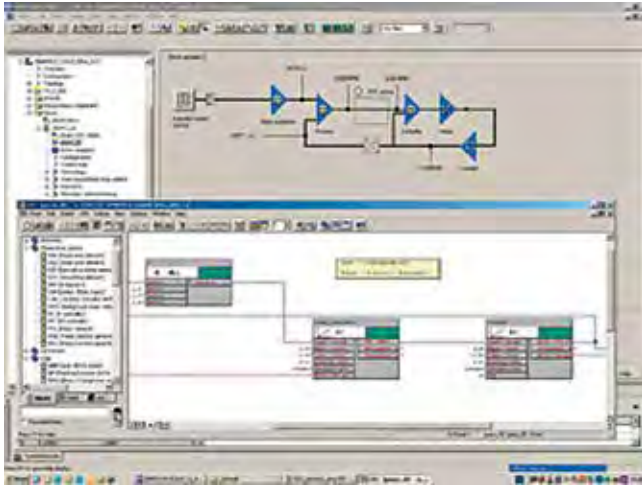

Drive Control Chart expands the possibility for very simply configuring technological functions, both for the SIMOTION motion control system as well as for the SINAMICS S120 drive system. For users, this opens up a new dimension regarding the adaptability of the systems mentioned to the specific functions of their machines.

DCC has no restrictions with regard to the number of usable functions; this is only limited by the performance capability of the target platform.

The user-friendly DCC Editor enables easy graphics-based configuration, allows control loop structures to be clearly represented and provides a high degree of reusability of diagrams that have already been created.

The open-loop and closed-loop control functions are defined by using multi-instance-capable blocks (Drive Control Blocks (DCBs)) from a pre-defined library (DCB library) that are selected and graphically linked with one another by dragging and dropping. Test and diagnostic functions allow the program behavior to be verified and, in the case of a fault, the cause identified.

The block library encompasses a large selection of closed-loop, arithmetic and logic blocks, as well as comprehensive open loop and closed-loop control functions.

For logically combining, evaluating and acquiring binary signals, all commonly used logic functions are available for selection (AND, XOR, on/off delay, RS flipflop, counter, etc.). A wide range of arithmetic functions, such as absolute value generation blocks, dividers and minimum/maximum evaluation are available to monitor and evaluate numerical quantities. In addition to the closed-loop drive control, axial winder functions, closed-loop PI controllers, ramp-function generators or wobble generators can be configured simply and easily.

Drive Control Chart for SINAMICS S120 also provides a convenient basis for resolving drive-level open-loop and closed-loop control tasks directly in the converter. This further extends the possibility of adapting SINAMICS to the particular application. Local data processing in the drive supports the implementation of modular machine concepts and results in an increase in the overall machine performance.

#### Minimum hardware and software requirements

See the STARTER engineering software, since DCC is installed in addition to this.

#### Selection and ordering data (options)

DCC comprises the graphic configuring tool (DCC Editor) and the block library (DCB library).

DCC is installed in addition to the SCOUT or STARTER engineering software.

The engineering license required for each PC (floating) for DCC is purchased at the same time the order is placed; additional runtime licenses are not required.

DCC can be ordered in two versions: as version for SIMOTION and SINAMICS applications, or as version for SINAMICS applications only.

Existing licenses for DCC V2.1 can also be used for DCC V2.2 SP1.

An upgrade variant for the engineering license can be selected for existing DCC V2.0 versions.

Description	Order No.
<b>DCC SIMOTION/SINAMICS V2.2 SP1 for SCOUT/STARTER V4.3 SP1</b> Graphical configuration with drive Control Chart DCC Editor + DCB library for use on SIMOTION and SINAMICS S120	6AU1810-1JA22-1XA0 6AU1810-1JA22-1XE0
<ul style="list-style-type: none"> <li>• Single Engineering License, with data carrier</li> <li>• Upgrade Engineering License, with data carrier</li> </ul>	
<b>DCC SINAMICS V2.2 SP1 for STARTER V4.3 SP1</b> Graphical configuration with drive Control Chart DCC Editor + DCB library for use on SINAMICS S120	6AU1810-1HA22-1XA0 6AU1810-1HA22-1XE0
<ul style="list-style-type: none"> <li>• Single Engineering License, with data carrier</li> <li>• Upgrade Engineering License, with data carrier</li> </ul>	

## Service tool

### Service tool

#### Mounting device for power blocks



Power block mounting device for installing and removing the power blocks for Basic Line Modules, Smart Line Modules, Active Line modules and Motor Modules in chassis format.

The mounting device is a mounting aid. It is placed in the front of the module and attached to the module. The telescopic rails allow the device to be adjusted to the installation height of the power blocks.

Once the mechanical and electrical connections have been released, the power block can be removed from the module.

The power block is guided and supported by the guide rails on the handling device.

#### Selection and ordering data

Description	Order No.
<b>Mounting device</b> for installing and removing power blocks	<b>6SL3766-1FA00-0AA0</b>

### Spare Parts

#### SparesOnWeb – Online spare parts catalog



SparesOnWeb is a web-based tool for determining the spare parts available for a SINAMICS drive. After you have registered and entered the serial number and order number, the spare parts available for the relevant unit are displayed.

[www.siemens.com/sow](http://www.siemens.com/sow)

### Complete life cycle service

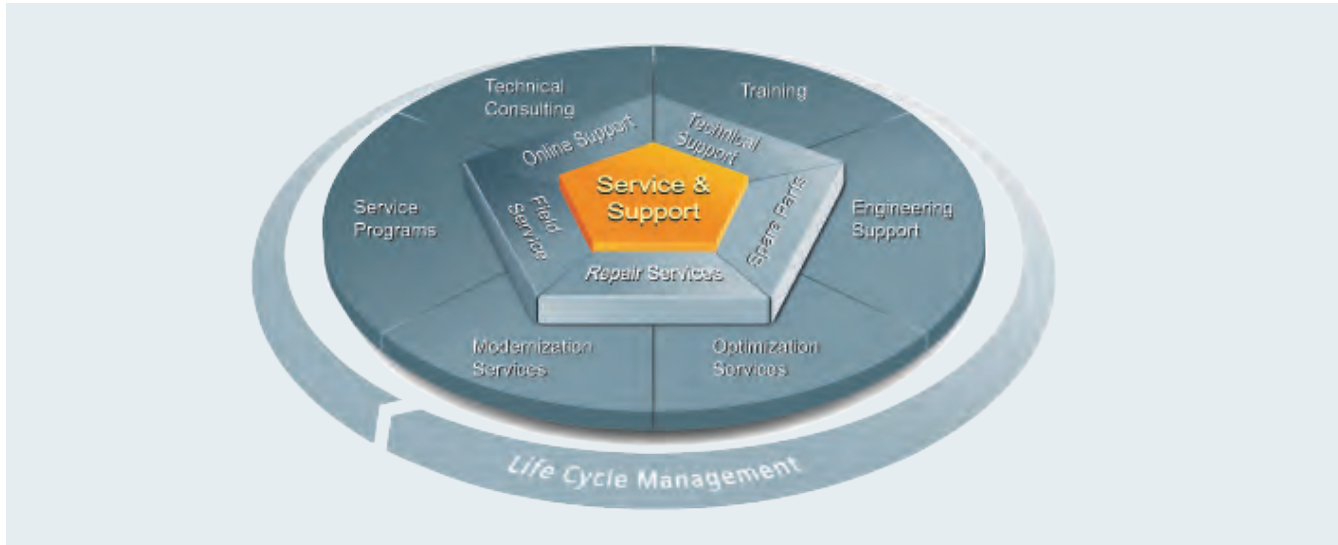

For machine constructors, solution providers and plant operators: The service offering from Siemens industry, Automation and Drive Technologies includes comprehensive services for a wide range of different users in all sectors of the manufacturing and process industry.

To accompany our products and systems, we offer integrated and structured services that provide valuable support in every phase of the life cycle of your machine or plant – from planning and implementation through commissioning as far as maintenance and modernization.

Our Service & Support accompanies you worldwide in all matters concerning automation and drives from Siemens. We provide direct on-site support in more than 100 countries through all phases of the life cycle of your machines and plants.

You have an experienced team of specialists at your side to provide active support and bundled know-how. Regular training courses and intensive contact among our employees – even across continents – ensure reliable service in the most diverse areas.

### Training

#### Start-up and maintenance training

Siemens Industry offers the following course for SINAMICS S120:

Course name: SINAMICS S Setup & Maintenance  
 Course code: SCT-DVSNAM1A  
 Duration: 4½ Days

This course provides training on Siemens' SINAMICS S drive systems family. Student will gain experience necessary to setup and maintain the operation of the SINAMICS S. The course includes an analysis of required hardware, steps for a quick startup, as well as additional application dependent steps for configuration, tuning and troubleshooting. A working knowledge of the drive communications capabilities will also be presented. The course also covers the extensive diagnostic capabilities of the drive.

Please see the Siemens Industry SITRAIN Internet site for dates and costs of scheduled classes at:  
<http://www.usa.siemens.com/training>

### Service & Support Contacts

#### Pre-sales Support, Order Entry

Please contact your local sales office.

GA400 facility, Alpharetta, GA

Phone: (770) 740-3000

e-mail: [drives-marketing.industry@siemens.com](mailto:drives-marketing.industry@siemens.com)

#### Technical Support

Inside USA, toll free: 1-800-333-7421

Outside USA: +1(423)262-5710

Online request: [www.siemens.com/automation/support-request](http://www.siemens.com/automation/support-request)

#### Customer Service, Field Services, Spare Parts & Repair

Inside USA, toll free: 1-800-241-4453

Outside USA: +1(423)262-5711

e-mail: [helpline.sii@siemens.com](mailto:helpline.sii@siemens.com)

**Siemens Industry, Inc.**  
3333 Old Milton Parkway  
Alpharetta, GA 30005

1-800-241-4453  
info.us@siemens.com

**[www.usa.siemens.com/drives](http://www.usa.siemens.com/drives)**

Subject to change without prior notice.

Order No: DRCA-D2171-0313

All rights reserved.

Printed in USA.

©2013 Siemens Industry, Inc.

The information provided in this brochure contains merely general descriptions or characteristics of performance which in case of actual use do not always apply as described or which may change as a result of further development of the products. An obligation to provide the respective characteristics shall only exist if expressly agreed in the terms of contract.

Siemens is a registered trademark of Siemens AG.  
Product names mentioned may be trademarks or registered trademarks of their respective companies. Specifications are subject to change without notice.