



System Maintenance Manual

GRA 55/5500 Bell 206 STC

**Contains Instructions for Continued Airworthiness
for Bell 206 STC**

**System Maintenance Manual
GRA 55/5500 Bell 206 STC**

as installed in

Bell 206B, 206L Series

Reg. No. _____ **S/N** _____

**Contains Instructions for Continued Airworthiness
for Bell 206 STC**

**Dwg. Number:
190-01277-A3 Rev. 1**

**Garmin International, Inc.
1200 E. 151st Street
Olathe, Kansas 66062 USA**

© 2014 Garmin International, Inc. or its subsidiaries
All Rights Reserved

Except as expressly provided herein, no part of this manual may be reproduced, copied, transmitted, disseminated, downloaded or stored in any storage medium, for any purpose without the express prior written consent of Garmin. Garmin hereby grants permission to download a single copy of this manual and of any revision to this manual onto a hard drive or other electronic storage medium to be viewed and to print one copy of this manual or of any revision hereto, provided that such electronic or printed copy of this manual or revision must contain the complete text of this copyright notice and provided further that any unauthorized commercial distribution of this manual or any revision hereto is strictly prohibited.

At Garmin, we value your opinion.

For comments about this guide, please e-mail Techpubs.Salem@garmin.com.

Garmin International Inc.
1200 E. 151st Street
Olathe, Kansas 66062
Telephone: (913) 397-8200
www.garmin.com

Aviation Dealer Technical Support
Telephone (Toll Free): (888) 606-5482
Fax: (913) 397-0868
Fax (Toll Free): (800) 801-4670
E-mail: orders@garmin.com
avionics@garmin.com
warranty@garmin.com

Garmin AT, Inc.
2345 Turner Rd. SE
Salem, OR 97302 USA
Telephone: (503) 581-8101
Telephone (Toll Free): (800) 525-6726
Canada: (800) 654-3415
Fax: (503) 364-2138
E-mail: support.salem@garmin.com

Garmin (Europe) Ltd.
Liberty House, Hounslow Business Park
Southampton, Hampshire SO40 9LR U.K.
Phone: +44 (0) 23 8052 4000
Fax: +44 (0) 23 8052 4004
Aviation Support +44 (0) 87 0850 1243

RECORD OF REVISIONS

Revision	Revision Date	Description
1	07/11/2014	Initial Release

CURRENT REVISION DESCRIPTION

Revision	Section Number(s)	Page Number(s)	Description of Change
1	All	All	Initial Release

DOCUMENT PAGINATION

Section	Pagination		
Table of Contents	ii	through	v
Section 1	1-1	through	1-2
Section 2	2-1	through	2-1
Section 3	3-1	through	3-8
Section 4	4-1	through	4-6
Section 5	5-1	through	5-7
Section 6	6-1	through	6-3
Section 7	7-1	through	7-1
Section 8	8-1	through	8-2
Section 9	9-1	through	9-1
Appendix A	A-1	through	A-7

INFORMATION SUBJECT TO EXPORT CONTROL LAWS

This document may contain information which is subject to the Export Administration Regulations (“EAR”) issued by the United States Department of Commerce (15 Code of Federal Regulations (CFR), Chapter VII, Subchapter C) and which may not be exported, released, or disclosed to foreign nationals inside or outside of the United States without first obtaining an export license. A violation of the EAR may be subject to a penalty of up to 10 years imprisonment and a fine of up to \$1,000,000 under Section 2410 of the Export Administration Act of 1979. Include this notice with any reproduced portion of this document.

This information in this document is subject to change without notice. Visit the Garmin web site (www.garmin.com) for current updates and supplemental information concerning the operation of Garmin products.

DEFINITIONS OF WARNINGS, CAUTIONS, AND NOTES



WARNING

Warnings are used to bring to the installer’s immediate attention that not only damage to the equipment but personal injury may occur if the instruction is disregarded.



CAUTION

Cautions are used to alert the individual that damage to equipment may result if the procedural step is not followed to the letter.



NOTE

Notes are used to expand and explain the preceding step and provide further understanding of the reason for the particular operation.

TABLE OF CONTENTS

1	INTRODUCTION	1-1
1.1	Purpose	1-1
1.2	Scope	1-1
1.3	Document Control	1-1
1.4	Permission to Use Certain Documents	1-1
1.5	Definitions	1-1
1.6	Terminology	1-2
1.7	Publications	1-2
1.7.1	Applicability	1-2
1.7.2	Definition of Abbreviations	1-2
1.7.3	Precautions	1-2
1.7.4	Units of measurement	1-2
1.7.5	Referenced publications (or their later revisions)	1-2
1.7.6	Retention	1-2
2	SYSTEM DESCRIPTION	2-1
2.1	Description of Alteration	2-1
2.2	Block Diagram	2-1
3	GRA 55/5500 CONTROL AND OPERATION	3-1
3.1	Control, Operating, and Testing Information	3-1
3.2	Downloading and Installing the GRA 55/5500 Retrofit Installation Tool	3-1
3.3	Using the GRA 55/5500 Retrofit Installation Tool	3-2
3.4	Installation Tool Pages	3-2
3.4.1	Status Page	3-3
3.4.2	Configuration Page	3-4
3.4.3	Software Page	3-5
3.4.4	Diagnostics Page	3-6
3.4.5	Utilities Page	3-7
3.4.6	Zero-Foot Calibration	3-8
4	INSTRUCTIONS FOR CONTINUED AIRWORTHINESS	4-1
4.1	Servicing Information	4-1
4.2	Periodic Maintenance	4-1
4.3	Special Tools	4-1
4.4	Maintenance Intervals	4-2
5	TROUBLESHOOTING INFORMATION	5-1
5.1	GRA 55/5500 General Troubleshooting	5-1
6	REMOVAL AND REPLACEMENT INFORMATION	6-1
6.1	Unit Installation	6-1
6.1.1	Installation Procedure	6-1
6.1.2	Removal Procedure	6-1
6.2	Rack Installation	6-1
6.2.1	Installation Procedure	6-1
6.2.2	Removal Procedure	6-1
6.3	Antenna Installation	6-1

TABLE OF CONTENT CONTINUED

6.3.1 Installation Procedure 6-1
6.3.2 Removal Procedure 6-2
7 RETURN TO SERVICE PROCEDURE7-1
7.1 Return to Service7-1
7.2 Maintenance Records7-1
8 LIMITATIONS AND ADDITIONAL REQUIREMENTS8-1
8.1 Diagrams8-1
8.2 Special Inspection Requirements8-1
8.3 Application of Protective Treatments8-1
8.4 Data Relative to Structural Fasteners8-1
8.5 Additional Instructions8-1
8.6 Overhaul Period8-1
8.7 ICA Revision and Distribution8-1
8.8 Assistance8-1
8.9 Implementation and Record Keeping8-2
9 AIRWORTHINESS LIMITATIONS SECTION9-1
APPENDIX A AIRCRAFT SPECIFIC INFORMATION A-1
A.1 Weight and BalanceA-5

LIST OF FIGURES

Figure 2-1.	GRA 55/5500 Block Diagram	2-1
Figure 3-1.	Installation Tool Page Tabs	3-2
Figure 3-2.	Status Page	3-3
Figure 3-3.	Configuration Page	3-4
Figure 3-4.	Software Page	3-5
Figure 3-5.	Diagnostics Page	3-6
Figure 3-6.	Utilities Page	3-7
Figure 6-1.	GRA 55/5500 Installation	6-2
Figure 6-2.	Rack Installation	6-3
Figure 6-3.	GRA 55/5500 Antenna Installation	6-3
Figure A-1.	GRA STC Equipment Fuselage Station Location for Bell 206	A-1
Figure A-2.	GRA STC Equipment Fuselage Station Location for Bell 206L Series	A-1
Figure A-3.	GRA 55/5500 Unit and Rack Installation in the Bell 206B, 206L Series	A-2
Figure A-4.	Overhead Circuit Breaker Panel in Bell 206B, 206L Series	A-3
Figure A-5.	GRA 55/5500 Wire Routing in the Bell 206B, 206L Series	A-4
Figure A-6.	GRA 55/5500 Unit Location and Moment Arm in Bell 206B, 206L Series	A-5
Figure A-7.	Bell 206B LRU and Antenna Locations	A-6
Figure A-8.	Bell 206L Series LRU and Antenna Locations	A-7

LIST OF TABLES

Table 4-1.	Maintenance Intervals for GRA 55/5500	4-2
Table 4-2.	Maintenance Intervals for Antennas Replaced Under this STC	4-4
Table 5-1.	GRA 5500 Fault Descriptions	5-1
Table A-1.	Bill of Materials	A-2
Table A-2.	Circuit Breaker Placard	A-3
Table A-3.	Weight and Balance Details	A-5

1 INTRODUCTION

1.1 Purpose

This document provides Instructions for Continued Airworthiness in compliance with requirements of 14 CFR §27.1529, and Part 27 Appendix A. This ICA is to be used by the agency installing the Garmin GRA 55/5500 radar altimeter system under the GRA 55/5500 STC. This document includes information required by the operator to adequately maintain the Garmin GRA55/5500 system as installed by this STC.

1.2 Scope

This document provides Instructions for Continued Airworthiness for the Bell 206B, 206L, L-1, L-3, and L-4 rotorcraft, modified by the installation of the Garmin GRA 55/5500 STC.

1.3 Document Control

This document is released, archived, and controlled in accordance with the Garmin document control system.

1.4 Permission to Use Certain Documents

Permission is granted to any corporation or person to use GRA 55/5500 STC documents to accomplish the Instructions for Continued Airworthiness and show compliance with STC engineering data when applying for approval. This permission does not construe suitability of the documents. It is the responsibility of the applicant to determine the suitability of the documents for the ICA.

1.5 Definitions

The following terminology is used within this document:

1. **ACO:**Aircraft Certification Office
2. **AEG:**Aircraft Evaluation Group
3. **AGL:**Above Ground Level
4. **BIT:**Built-In Test
5. **CFR:**Code of Federal Regulations
6. **FAA:**Federal Aviation Administration
7. **FMCW:** Frequency Modulated Continuous Wave
8. **FOD:**Foreign Object Damage
9. **ICA:**Instructions for Continued Airworthiness
10. **LRU:**Line Replaceable Unit
11. **NAV:**Navigation
12. **ODA:**Organization Designation Authorization
13. **PMI:**Principal Maintenance Inspector
14. **POI:**Principal Operations Inspector
15. **RX:**Receive
16. **STC:**Supplemental Type Certificate
17. **TSO:** Technical Standard Order
18. **TX:**Transmit

1.6 Terminology

Except where specifically noted, references made to the 'GRA' will equally apply to the GRA 55 and GRA 5500 radar altimeters.

Also, except where specifically noted, references made to the 'Bell 206L Series' will apply equally to the Bell 206L, Bell 206L-1, Bell 206L-3, and Bell 206L-4 models.

1.7 Publications

Content, Scope, Purpose and Arrangement: This document identifies the Instructions for Continued Airworthiness for the modification of the aircraft by the installation of the Garmin GRA 55/5500 Part 27 STC.

1.7.1 Applicability

Applies to aircraft altered by the installation of the Garmin GRA 55/5500 Part 27 STC.

1.7.2 Definition of Abbreviations

See Section 1.5 and Section 1.6.

1.7.3 Precautions

None.

1.7.4 Units of measurement

None.

1.7.5 Referenced publications (or their later revisions)

1. Bell Model 206B Maintenance Manual, Bell Document BHT-206B-MM, Revision 12, 1 June 2012
2. Bell Model 206L Maintenance Manual, Bell Document BHT-206L-MM, Revision 36, 1 June 2012
3. Bell Model 206L1 Maintenance Manual, Bell Document BHT-206L1-MM, Revision 33, 1 June 2012
4. Bell Model 206L3 Maintenance Manual, Bell Document BHT-206L3-MM, Revision 19, 1 June 2012
5. Bell Model 206L4 Maintenance Manual, Bell Document BHT-206L4-MM, Revision 16, 1 June 2012
6. Structural Repair Manual for Bell Model 206 Series Helicopters, BHT-206-SRM-1, Revision 1, April 1995
7. Electrical Standard Practices Manual for all Bell Helicopter Commercial Products, BHT-ELEC-SPM, Revision 2, July 2012

1.7.6 Retention

This document, or the information contained within, will be included in the aircraft's permanent records.

2 SYSTEM DESCRIPTION

2.1 Description of Alteration

This STC upgrades the existing functionality of the Bell 206B, 206L series aircraft avionics system as summarized below.

The GRA 55/5500 radar altimeter system features: two antenna architecture for transmitting and receiving radio waves for altitude quantities, remote mounted LRU transceiver for quantifying Above Ground Level (AGL) altitude information, and interface capabilities to the existing aircraft G500H Flight Deck System (FDS) for pilot display of aircraft altitude and system degraded warnings. The GRA 55/5500 radar altimeter may also integrate with an installed Garmin GTN 6XX/7XX for the purpose of providing the optional 50 ft callout as part of optional HTAWS functionality.

The GRA 55/5500 LRU which is 3.99"x3.02"x11.62" mounted, is located on the supplied mounting rack that is electrically bonded to the avionics shelf. The two approved radar altimeter antennas are optimally located on the underside of the tailboom, separated by a minimum distance of 20" on center using approved antenna mounts installed via STC SR09598RC, STC SR02162LA or other mounting provisions that are compatible with the approved radar altimeter antennas. The system requires a 5 Amp minimum circuit breaker installed on the overhead panel to supply power.

2.2 Block Diagram

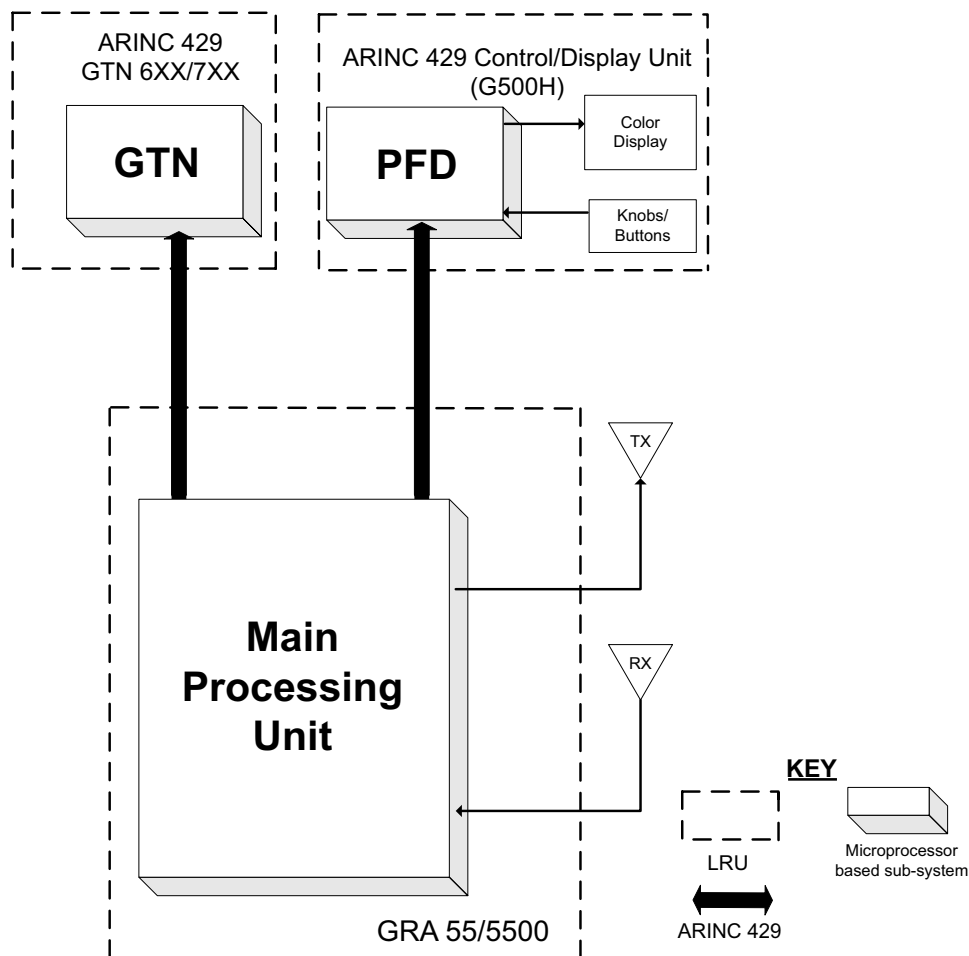

Figure 2-1. GRA 55/5500 Block Diagram

3 GRA 55/5500 CONTROL AND OPERATION

3.1 Control, Operating, and Testing Information

The GRA 55/5500 is a fully automated, remote-mounted LRU which requires no user controls or inputs. The GRA 55/5500 displays the radar altitude height above ground level on compatible display systems. Radar altitudes will be displayed ranging from ground level to 2550ft AGL.

The GRA 55/5500 has a built-in self-test (BIST/BITE) and fault logging functionality which includes automated self-test and fault detection monitoring of the entire internal TX and RX circuitry. This feature occurs every time the unit power is cycled and subsequently every minute during normal operation at calculated altitudes ranging from 250ft to 2550ft AGL and during “No Computed Data” (NCD) conditions.

The GRA 55/5500 will encounter NCD conditions; at actual altitudes above 2550ft AGL, during excess pitch or roll maneuvering, or anytime the ground reflection is poor.

3.2 Downloading and Installing the GRA 55/5500 Retrofit Installation Tool

GRA 55/5500 configuration, calibration, diagnostics, and software upgrades are performed using a personal computer (installed with Microsoft Windows XP Service Pack 3 or later) and the GRA 55/5500 Retrofit Installation Tool, Garmin part number 006-A0451-00. The tool is available for download from the Dealer Resource Center portion of the Garmin website (www.garmin.com). See the accompanying “readme” file in the tool’s installation directory for the latest instructions.



NOTE

A standard USB-A plug to USB-B plug commercial cable (not provided) is required to interface between a personal computer USB-A receptacle and the GRA 55/5500 USB-B receptacle installed in the wiring harness. This dongle cable is required to use the GRA 55/5500 Retrofit Installation Tool.

Installation

1. Once downloaded, launch the installation file from the directory in which it is stored (or use the web browser’s download shortcuts).
2. The GRA 55/5500 Retrofit Installation Tool Setup Wizard will begin.
3. Click “Next” as prompted by the setup wizard, and adjust any settings (e.g. installation directory) as needed.
4. The last screen of the setup wizard will show “Installation Complete.” Click the “Close” button to close the setup wizard.

3.3 Using the GRA 55/5500 Retrofit Installation Tool

Once the GRA 55/5500 Retrofit Installation Tool has been installed:

1. Connect the PC to the GRA 55/5500
2. Start the GRA 55/5500 Retrofit Installation Tool from the provided “Start Menu” shortcut, or launch the application from its program folder
3. Power-up the GRA 55/5500 by applying aircraft power
4. The connection status in the lower, right-hand corner of the GRA 55/5500 Retrofit Installation Tool will transition from “Not Connected,” to “Connected.”
5. If the GRA 55/5500 Retrofit Installation Tool does not display “Connected” in the lower, right-hand corner, check the installation and make sure the GRA 55/5500 has been powered-up and that the USB cable is properly connected to the PC.

If the PC displays a “Found New Hardware” wizard, the GRA 55/5500 Retrofit Installation Tool was not able to automatically install the device driver. It may be necessary to manually install the device drivers. Copies of the drivers’ “.inf” and “.dll” files are located in the target installation directory selected during installation. Consult the PC’s operating system documentation on manually installing drivers.

3.4 Installation Tool Pages

The Installation Tool contains five tabbed pages, all of which can be useful in troubleshooting a problem. The pages are: Status, Configuration, Software, Diagnostics, and Utilities (See Figure 3-1).

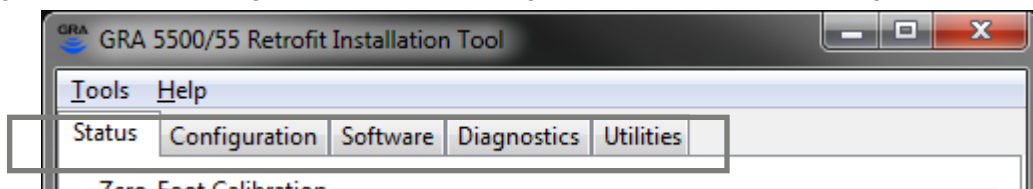

Figure 3-1. Installation Tool Page Tabs

3.4.1 Status Page

The status page (Figure 3-2) is displayed by selecting the Status tab. This page provides the basic fault status of the unit. During normal operation, the status of each fault should indicate “normal.” If the unit indicates a fault, the fault’s entry on the list is displayed in a bold, red font. The status also updates to show the specific failure under that fault. Table 5-1 identifies the various unit faults that can be encountered during normal operation of the GRA 55/5500. Use Table 5-1 as a reference to determine the proper actions to take after a fault has been identified.

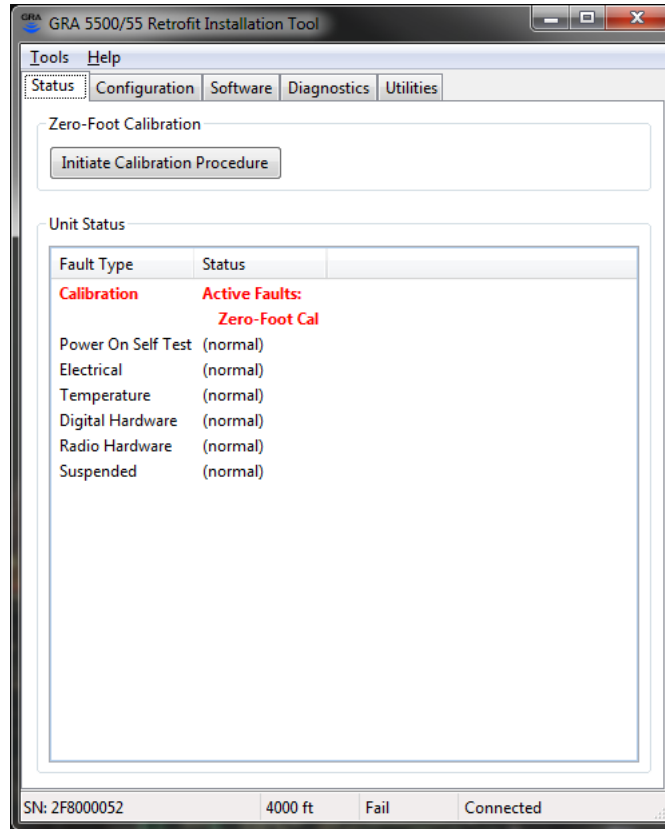

Figure 3-2. Status Page

3.4.2 Configuration Page

The configuration page (Figure 3-3) provides an interface to change the unit's per-airframe configuration. The configuration tab displays the unit's current settings. After adjusting any settings, the "Save Configuration to Unit" button must be clicked to send the configuration values to the GRA 55/5500. Clicking the button labeled "Restore Defaults to Unit" restores all settings to their default, factory state. The GRA 55 does not utilize ARINC 429 Channel 2 and that section will not be selectable.

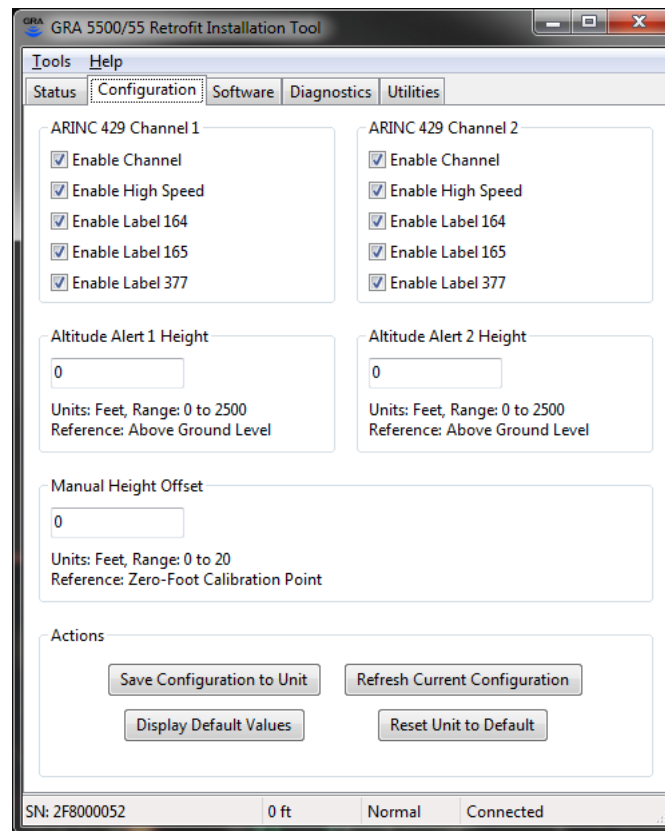

Figure 3-3. Configuration Page

3.4.3 Software Page

The software page (Figure 3-4) provides a list of currently installed software regions on the GRA 55/5500 as well as an interface to load new software regions to the unit.

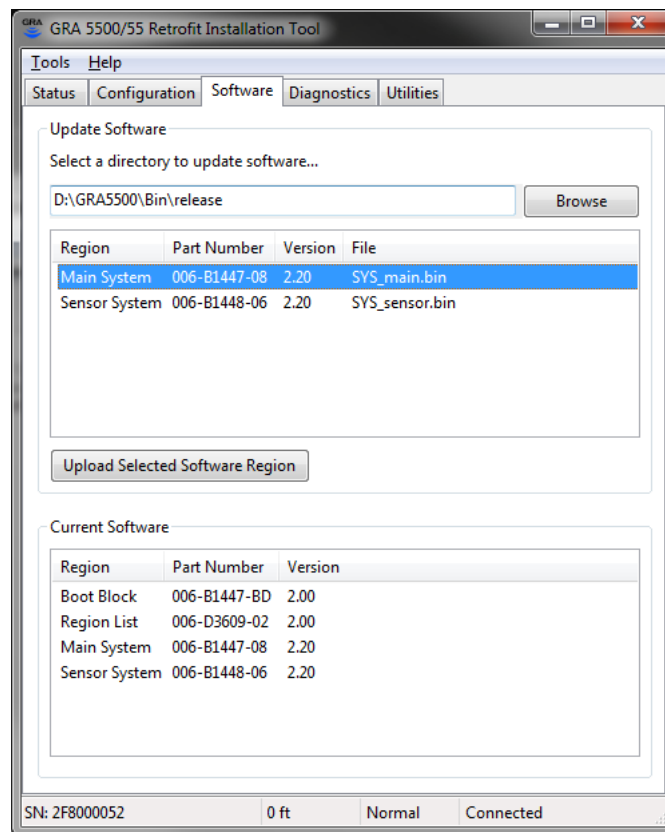

Figure 3-4. Software Page

3.4.4 Diagnostics Page

The Diagnostics Page (see Figure 3-5) allows the user to download the unit’s assert log. In normal condition, there should be no logged asserts and this page will be disabled. If an assert has been logged to the unit, the “Download Asserts” button will be selectable. This will download the logged asserts from the unit and display them on the Assert Log Records list. Basic information about each assert (the power-on cycle, the total power-on time, the type of fault or assert, and the status message accompanying the assert) is displayed.

The “Capture Raw Log to File...” button and the “Export Log to CSV...” button may be used to save the assert log (for further diagnostic evaluation). The raw log option will be most helpful when communicating issues to Garmin Engineering. The CSV log option will be most helpful for end-users not familiar with the internal logging format. These two buttons will only be selectable after the assert log has been downloaded from the unit.

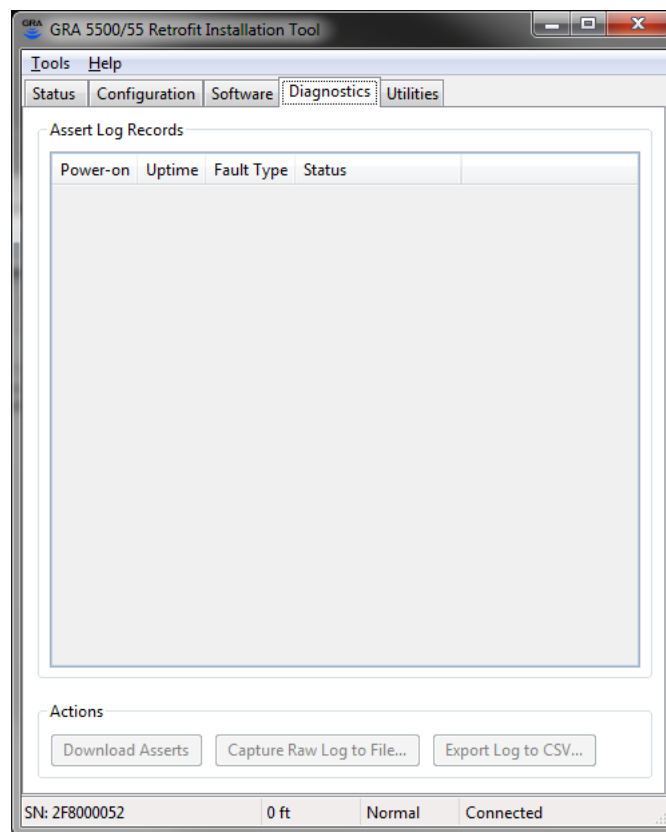

Figure 3-5. Diagnostics Page

3.4.5 Utilities Page

The Utilities Page (see Figure 3-6) displays statistics and information about the current state of the unit. These values are updated every two seconds. All values are labeled, and include units (where necessary). Minimum and Maximum internal temperatures experienced by the unit during operation are also displayed.

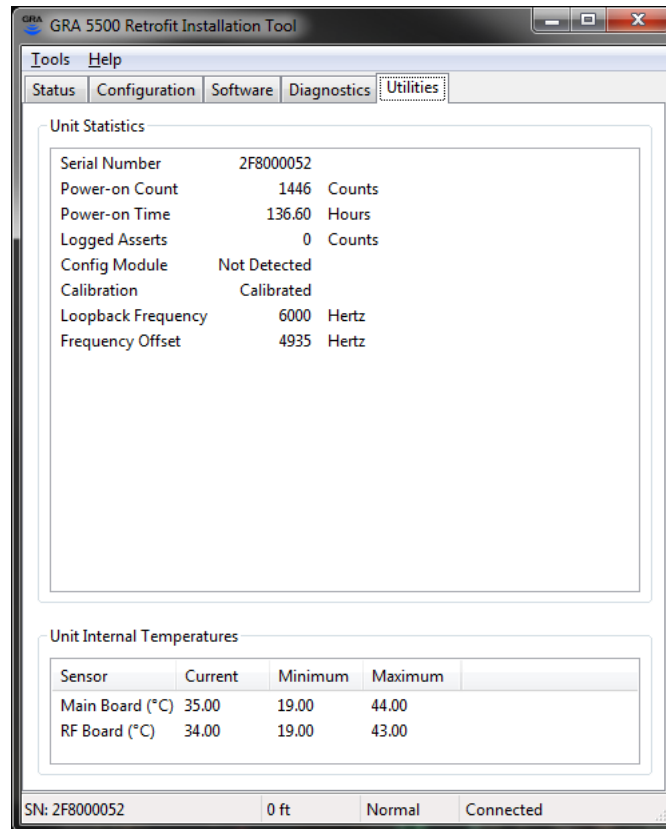

Figure 3-6. Utilities Page

3.4.6 Zero-Foot Calibration

Anytime the GRA 55/5500 is removed and reinstalled in the helicopter, a one-time zero-foot calibration procedure must be performed on the unit in order to “zero” the altitude outputs from the unit. This procedure removes the altitude offsets associated with antenna cables, antenna height above ground, etc. This procedure is performed via the GRA 55/5500 Retrofit Installation Tool.

The following conditions must be met before the zero-foot calibration procedure should be attempted:

1. The entire GRA 55/5500 must be completely installed and mounted in the final configuration as representative of normal flight conditions.
2. A visual inspection must be performed to verify antenna installation and the antenna coaxial cables are installed and connected properly.
3. The zero-foot calibration procedure must be performed outdoors on a hard, flat surface and away from hangars, buildings, or other metal structures that may reflect the radar signal.
4. GRA 55/5500 Retrofit Installation Tool must be connected to the GRA via USB dongle cable.

The GRA 55/5500 Retrofit Installation Tool provides an interface button to initiate the zero-foot calibration procedure. Clicking this button will make a series of requests to the connected GRA 55/5500. During the calibration procedure, the GRA 55/5500 Retrofit Installation Tool will report progress updates next to the “Initiate Calibration Procedure” button. Once the calibration procedure has completed, the text will display “Calibration Complete” and the status tab will be updated. If the fault list does not announce any faults and the information displayed in the status bar area indicates “0 ft” and “Normal,” the unit has been successfully calibrated.

4 INSTRUCTIONS FOR CONTINUED AIRWORTHINESS

4.1 Servicing Information

None. In the event of system failure, troubleshoot the GRA 55/5500 in accordance with Section 5 of this document.

4.2 Periodic Maintenance

The GRA is designed to detect internal failures. A thorough self-test is executed automatically upon application of power to the unit. Furthermore, automated built-in tests (BIT) are continuously executed every minute within the altitude range of 250ft to 2550ft.

Operation of the GRA 55/5500 is not permitted unless the inspections described in this section have been completed within the time intervals prescribed in Table 4-1.

4.3 Special Tools

A milliohm meter with an accuracy of +/- 0.1 milliohms ohms (or better) is required to measure the electrical bonding between the GRA 55/5500 LRU and aircraft ground.

4.4 Maintenance Intervals

Table 4-1. Maintenance Intervals for GRA 55/5500

Item	Description/Procedure	Interval
Equipment Removal and Replacement	Removal and replacement of the following items. See Section 6 for removal and replacement instructions. <ul style="list-style-type: none"> • GRA 55/5500 Mount Rack • GRA 55/5500 LRU • Antenna 	On Condition
Test – Bonding Check, GRA 55/5500 & MOUNT RACK	Perform an electrical bonding check as follows: <ol style="list-style-type: none"> 1. Disconnect the wire harnesses from the GRA 55/5500 at P55001, TX, and RX connections. 2. Measure the resistance between the mounting rack and a nearby exposed portion of metallic structure. Verify that the resistance is less than or equal to 2.5 milliohms. 3. Measure the resistance between the GRA 55/5500 LRU and the mounting rack. Verify that the resistance is less than or equal to 2.5 milliohms. In the event of a bonding test failure, remove the LRU and rack, if required, and verify that the mating surfaces for the LRU and/or mounting rack are free of corrosion or any other debris. Clean, inspect and re-burnish (if required) all mating surfaces using approved methods and solvents per Bell specification BHT-ELEC-SPM CHP 8. Reinstall the mounting rack and GRA LRU to the designated location. Re-verify the resistance between the mounting rack and nearby exposed portion of aircraft metallic structure and ensure that the resistance is less than or equal to 2.5 milliohms . Re-verify the resistance between the GRA LRU the mount rack. Ensure the resistance is less than or equal to 2.5 milliohms . <ol style="list-style-type: none"> 4. Reconnect the previously disconnected wire harnesses ensuring that the coaxial connectors are reconnected into their respective locations. 	To be performed in alignment with Bell 206B, 206L series maintenance schedule. Every 10 years or every 2000 hours, whichever comes first.

Item	Description/Procedure	Interval
Hard Landing Inspection	<ol style="list-style-type: none"> 1. Complete visual examination of rotorcraft structure (shelf) supporting GRA unit for damage to verify integrity, including unit mounting rack and rack fasteners. Check and re-torque mounting rack fasteners 20 to 25 in-lbs if required. Repair GRA unit support structure in accordance with BHT-206-SRM-1 Structural Repair Manual, and BHT-ALL-SPM Bell Standard Practices Manual if required. 2. Visually inspect integrity of the GRA unit for damage. Operation of the GRA unit is verified through unit self-test at power-up. 3. Visually inspect integrity of the GRA antennas, antenna fasteners, and antenna sealant for damage. If required, check and re-torque antenna fasteners 20 to 25 in-lbs, and remove and replace antenna sealant (MIL-A-46146). 4. Inspect all system connectors for FOD and check for bent, broken, or recessed pins. 	On Condition

Item	Description/Procedure	Interval
Visual Inspection	<p>The GRA mount, unit and wiring harnesses should be inspected to ensure continued integrity of the installation in alignment with Chapter 5, under the relevant section covering 100-Hour and Annual Inspections of applicable Bell 206B, 206L series Model Maintenance Manual. Perform a visual inspection of the GRA unit, unit mount, and wiring harnesses to verify integrity.</p> <ol style="list-style-type: none"> 1. Inspect the GRA unit for security of attachment, including visual inspection of the mounting rack and rotorcraft support structure to which the rack is attached. Verify the fastener heads are in full contact with unit mounting rack and re-torque 20 to 25 in-lbs if required. 2. Inspect GRA55/5500 unit, unit mounting rack, and rotorcraft support structure for signs of corrosion and apparent signs of damage. If corrosion is found, treat affected areas in accordance with Chapter 3 of BHT-ALL-SPBM Bell Helicopter Standard Practices Manual, Revision 2, or later approved revision. If damage to GRA unit support structure is found, repair as required in accordance with BHT-206-SRM-1 Structural Repair Manual, Revision 3, or later approved revision. 3. Inspect placards and all labels. Ensure that they are legible and properly adhered. Damaged placards and labels should be replaced as necessary. 4. Inspect wire and shield terminations, condition of wiring harness, routing, and security of its attachment/clamping to rotorcraft structure. Check for chaffed or damage wires and ensure overall functionality of wire installation. 5. Inspect all system connectors for bent/broken or recessed pins. Inspect connectors for FOD. 	<p>To be performed in alignment with Bell 206B, 206L series maintenance schedule. Every 100 flight hours or every 12 months, whichever comes first.</p>

Table 4-2. Maintenance Intervals for Antennas Replaced Under this STC

Item	Description/Procedure	Interval
<p>Test – Bonding Check, Antennas</p>	<p>An electrical bonding test must be performed on antennas installed by this STC.</p> <ol style="list-style-type: none"> 1. Gain access to the antenna installation. 2. Remove one each mounting screw from the antenna if not already done. Check that the remaining hardware is installed and properly torqued. 3. Measure the resistance between the exposed metal in the empty mounting hole of the antenna and a nearby exposed portion of conductive aircraft structure (i.e. exposed rivet). Verify that the resistance is less than or equal to 2.5 milliohms. 4. Reinstall the antenna mounting screw, torque as specified. Reseal the antenna as required. <p>In the event of a bonding test failure, remove the failed antenna, Clean and inspect all hardware and mating surfaces using approved solvents and methods per Bell specification BHT-ELEC-SPM CHP 8.</p> <p>For antennas that are secured with nuts and bolts, clean the fastener hole in the antenna and the underside of the fastener head itself. Prep the area underneath the washer on the inner mould line of the skin in accordance with Bell Specification BHT-ELEC-SPM CHP 8. If nutplates are used in lieu of a nut, the technician is only required to clean the underneath of the fastener head and the fastener hole.</p> <p>For antennas that use stud mounts, prep the area underneath the washer on the inner mould line of the skin in accordance with Bell Specification BHT-ELEC-SPM CHP 8.</p> <p>Re-install using Antenna Installation procedures in Section 6.3. Any reworked antenna installation shall have a resistance of less than or equal to 2.5 milliohms.</p> <p>Re-seal the antenna as per methods specified in BHT-ELEC-SPM CHP 8.</p>	<p>To be performed in alignment with Bell 206B, 206L series maintenance schedule. Every 10 years or every 2000 hours, whichever comes first.</p>

Item	Description/Procedure	Interval
<p>Visual Inspection of the antennas</p>	<p>Visual inspection on the antenna:</p> <ol style="list-style-type: none"> 1. Clean the antenna with water and mild soap. 2. Verify there are no cracks on the antenna and around attachment fasteners. 3. Verify that all sealing fillets around the antenna are in good condition. <p>If the antenna is broken, cracked, or dented it must be replaced.</p> <p>In the event attachment is not secure, re-attach antenna and complete the Electrical Bonding Test.</p> <p>In the event the antenna seal shows signs of damage, complete the Electrical Bonding Test and re-seal the antenna.</p> <p>Visual inspection of the rotorcraft exterior skin around installed antenna:</p> <ol style="list-style-type: none"> 1. Clean the exterior of the aircraft skin within a 10 inch radius of the antenna with water and mild soap. 2. Inspect aircraft skin around the antenna footprint to verify there are no cracks and aircraft skin is not deformed. 3. Verify that antenna fasteners are not loose. <p>If the aircraft skin is cracked, or deformed, the internal structure must also be inspected for degradation in the local area. Refer to approved method defined in the Structural Repair Manual For Bell Model 206 Series Helicopters, BHT-206-SRM- 1, Section 3 for applicable repairs.</p>	<p>To be performed in alignment with Bell 206B, 206L series maintenance schedule. Every 100 flight hours or every 12 months, whichever comes first.</p> <p>Perform visual inspection in event of suspected lightning strike.</p>

5 TROUBLESHOOTING INFORMATION

5.1 GRA 55/5500 General Troubleshooting

This section provides troubleshooting information for the Garmin GRA 55/5500 Radar Altimeter. All faulty units must be returned to Garmin for repair.

No internal or comprehensive unit troubleshooting is possible at the dealer service center due to the need for specialized unit test setups and test software. However, the service center may troubleshoot a unit to confirm a fault or the status of the unit by utilizing the following methods:

- Checking the status of monitored unit faults
- Checking the unit software versions
- Checking the unit installation configuration
- Downloading and analyzing the unit assert log
- Checking the unit statistics and internal recorded unit temperatures

The troubleshooting methods listed herein are employed using the GRA 55/5500 Retrofit Installation Tool as described in the following sections.

Table 5-1. GRA 5500 Fault Descriptions

Fault Type	Fault Name	Description	Cause	Resolution
Configuration	N/A	Unit does not boot	GRA HW Revision ID invalid for SW version	Update software to correct version for hardware
			GRA Unit ID invalid (Both discrete inputs grounded)	Check Unit ID strapping and set to a valid ID
			Hardware failure	Return unit to Garmin for service
Calibration	Zero-Foot Lock	Average frequency of zero-foot signal is larger/smaller than allowable frequencies	Improper antenna connections	Check antenna installation and all cable connections and retry calibration. Note there are no assert log entries for this fault.
	Zero-Foot Cal	Zero-Foot point is not set	Calibration not complete	Calibrate unit while on ground. Note there are no assert log entries for this fault.

Fault Type	Fault Name	Description	Cause	Resolution
POST (Power On Self-Test)	PLL Register	After programming, read-back of the PLL register values does not match what was sent from the CPU	Internal communication error	Cycle power to unit. If fault persists, return unit to Garmin for service.
	RF Self-Test	The self-test signal is not within the acceptable frequency range	Improper antenna connections	Check antenna installation and all cable connections.
			Internal failure	Download the assert log and send to Garmin for diagnosis. If fault persists, return unit to Garmin for service.
	Sensor Boot	Sensor processor software not successfully loaded	Internal communication error	Cycle power to unit. If fault persists, return unit to Garmin for service.
	Various [1]	Numerous tests identified in this table are run during Power On Self-Test (POST). Failure of these tests is identified as a POST fault during power up and also identified by the fault name in the fault log.	Various [1]	

Fault Type	Fault Name	Description	Cause	Resolution
Digital HW	Clock Generator I2C	Clock Generator is read to determine correct frequency output.	Internal communication error	Cycle power to unit. If fault persists, return unit to Garmin for service.
	Main Temp Sensor I2C	Temperature Sensor is read to determine correct operation.		
	RF Temp Sensor I2C			
	ADC (Voltage Monitor)	ADC did not respond to sampling conversion command within 20us	ADC failure	
	ADC Monitor (X) (Fault also included in POST, Power On Self Test Faults) [1]	ADC used to monitor internal unit voltages fails self-test		
	Clock Generator Register	Clock generator programming failure	Clock generator failure	
	DDR	Memory integrity test	Memory failure	
	Flash-to-RAM Code	Failed to validate code sections in memory	Code corrupted in flash memory	
	Code corrupted during transfer from flash to RAM			
Digital HW	Sensor Code CRC	Sensor processor code failed validity check	Code corrupted during transfer from flash to main processor	Cycle power to unit. If fault persists, return unit to Garmin for service.
			Code corrupted during transfer from main to sensor processor	
	Sensor Status	Sensor CPU fails to respond to Main CPU or packet information is not correct from sensor	Sensor processor failure	
			Internal communication error	
	Sensor Watchdog	Sensor processor reset signal triggered by sensor watchdog	Sensor processor failure	
			Internal communication error	

Fault Type	Fault Name	Description	Cause	Resolution
Electrical	(+ / -) 12.5V Monitor (Fault also included in POST, Power On Self Test Faults) [1]	(+ / -) 12.5 V power rail outputs improper voltage	Aircraft power input voltage out of range	Check aircraft power supply. Cycle power to unit.
			Internal power supply failure	If fault persists, download the assert log and send to Garmin for diagnosis.
	+12.5V RF Monitor (Fault also included in POST, Power On Self Test Faults) [1]	+12.5 V RF power rail outputs improper voltage	Aircraft power input voltage out of range	Check aircraft power supply. Cycle power to unit.
			Internal power supply failure	If fault persists, download the assert log and send to Garmin for diagnosis.
	+8V RF Monitor (Fault also included in POST, Power On Self Test Faults) [1]	+8 V RF power rail outputs improper voltage	Aircraft power input voltage out of range	Check aircraft power supply. Cycle power to unit.
			Internal power supply failure	If fault persists, download the assert log and send to Garmin for diagnosis.
	+80V Backup Monitor (Fault also included in POST, Power On Self Test Faults) [1]	+80 V backup power rail outputs improper voltage	Aircraft power input voltage out of range	Check aircraft power supply. Cycle power to unit.
	-6V RF Monitor (Fault also included in POST, Power On Self Test Faults) [1]	-6 V RF power rail outputs improper voltage	Aircraft power input voltage out of range	Check aircraft power supply. Cycle power to unit.
			Internal power supply failure	If fault persists, download the assert log and send to Garmin for diagnosis.

Fault Type	Fault Name	Description	Cause	Resolution
Electrical	+5.75V RF Monitor (Fault also included in POST, Power On Self Test Faults) [1]	+5.75 V RF power rail outputs improper voltage	Aircraft power input voltage out of range	Check aircraft power supply. Cycle power to unit.
	Internal power supply failure		If fault persists, download the assert log and send to Garmin for diagnosis.	
	+5.75V Monitor (Fault also included in POST, Power On Self Test Faults) [1]	+5.75 V power rail outputs improper voltage	Aircraft power input voltage out of range	Check aircraft power supply. Cycle power to unit.
	Internal power supply failure		If fault persists, download the assert log and send to Garmin for diagnosis.	
	+3.3V Monitor (Fault also included in POST, Power On Self Test Faults) [1]	+3.3 V power rail outputs improper voltage	Aircraft power input voltage out of range	Check aircraft power supply. Cycle power to unit.
	Internal power supply failure		If fault persists, download the assert log and send to Garmin for diagnosis.	
	+1.9V Monitor (Fault also included in POST, Power On Self Test Faults) [1]	+1.9 V power rail outputs improper voltage	Aircraft power input voltage out of range	Check aircraft power supply. Cycle power to unit.
	Internal power supply failure		If fault persists, download the assert log and send to Garmin for diagnosis.	
Electrical	Current Monitor	Improper current on +8 V power rail	Aircraft power input voltage out of range	Check aircraft power supply. Cycle power to unit.
			Internal power supply failure	If fault persists, download the assert log and send to Garmin for diagnosis.

Fault Type	Fault Name	Description	Cause	Resolution
Suspended	Power Fail	Aircraft power lost for greater than 220 ms	Internal power supply failure	Check aircraft power supply. Cycle power to unit.
			Aircraft power failure	Return power to unit. Note there are no assert log entries for this fault.
Radio HW	DDS	Failure to program DDS or read back correct register information from the DDS	Internal communication error	Cycle power to unit. If fault persists, return unit to Garmin for service.
	TX PLL Lock	The TX PLL is not locked while the unit is transmitting.	Internal failure	If fault persists, download the assert log and send to Garmin for diagnosis.
	LO PLL Lock	The LO PLL is not locked while the unit is transmitting	Internal failure	If fault persists, download the assert log and send to Garmin for diagnosis.
	Auto RF Self-Test	The self-test signal is not within the acceptable frequency range	Improper antenna connections	Check antenna installation and all cable connections.
			Internal failure	If fault persists, download the assert log and send to Garmin for diagnosis.
	Main RF Self-Test	The self-test signal is not within the acceptable frequency range	Improper antenna connections	Check antenna installation and all cable connections.
			Internal Failure	Download the assert log and send to Garmin for diagnosis. If fault persists, return unit to Garmin for service.

Fault Type	Fault Name	Description	Cause	Resolution
Temperature	Main Temp <i>(Fault also included in POST, Power On Self Test Faults) [1]</i>	Main board temperature greater than 100° C or less than -60° C	Installed unit location is too hot/cold	Return unit to qualified temperature range as specified in Environmental Qualification Form (EQF). If fault persists, return unit to Garmin for service.
			Internal failure	
	RF Temp <i>(Fault also included in POST, Power On Self Test Faults) [1]</i>	RF board temperature greater than 100° C or less than -60° C	Installed unit location is too hot/cold	
			Internal failure	

[1] Fault can be found in the Power on Self Test (POST) fault list and in normal operational mode fault list. Review Table 5-1 fault tree for identification.

6 REMOVAL AND REPLACEMENT INFORMATION

6.1 Unit Installation

6.1.1 Installation Procedure

1. Place the unit on the mounting rack, ensuring the GRA 55/5500 rear feet are aligned in the mounting rack slots.
2. Slide the GRA 55/5500 back until the feet are fully engaged with the mounting rack.
3. Lift the lockdown collar in place on the GRA 55/5500 hook and hand turn the lockdown mechanism knob clockwise until the GRA 55/5500 is secure and the knob cannot reasonably be ratcheted any tighter by hand.

6.1.2 Removal Procedure

1. Pull back on the lockdown mechanism and simultaneously turn counterclockwise until free.
2. Disengage the lockdown mechanism collar from the GRA 55/5500 hook and slide the GRA 55/5500 forward to remove from the mounting rack.

6.2 Rack Installation

The GRA 55/5500 mounting surface should be capable of providing a sufficient electrical bond to the aircraft to minimize Electromagnetic Interference (EMI) and provide protection from High-Intensity Radiation Fields (HIRF). Bonding resistance measured between the GRA 55/5500 mounting rack and the airframe must measure less than 2.5 milliohms.

6.2.1 Installation Procedure

1. Clean and inspect the mounting surface of the rack mount. Ensure the bonding surface is adequate to meet the required resistance measurement of 2.5 milliohms.
2. Place the rack on the mounting shelf assembly with lockdown knob facing forward.
3. Install and secure mount rack with 4 ea. screw (see Table A-1 for rack fasteners). Torque 20-25 in lbs.
4. Perform bond resistance measurement. Value should be less than 2.5 milliohms.

6.2.2 Removal Procedure

1. Remove GRA 55/5500 unit if not already done.
2. Remove 4 ea. screw (see Table A-1 for rack fasteners).
3. Remove mounting rack.

6.3 Antenna Installation

6.3.1 Installation Procedure

1. Clean and inspect the antenna mount. Remove debris and excess sealant if replacing existing antenna.
2. Apply the conductive gasket on the underside of the antenna using the fastener holes as guides.
3. Use MS24693-C272 stainless steel countersunk head machine screws (No. 10, supplied) to secure antennas. Verify that directional arrow on the antenna is pointed towards the front of the helicopter.
4. Torque antenna fasteners in a star pattern to 20-25 in lbs. Torque should be applied evenly across all fasteners to avoid deformation of the mounting area.
5. Ensure that the antenna base and antenna mount are in continuous contact with the gasket.

6. Seal the antenna and gasket with an approved sealant compound (MIL-A-46146) along the edge of the antenna where it meets the antenna mount.

6.3.2 Removal Procedure

1. Remove the sealant compound (MIL-A-46146) along the edge of the antenna where it meets the antenna mount using a non-metallic scraper.
2. Remove the hardware retaining the antenna in place.
3. Lower the antenna enough to disconnect the coaxial connector, and disconnect.
4. Remove the antenna and conductive gasket from the airframe.

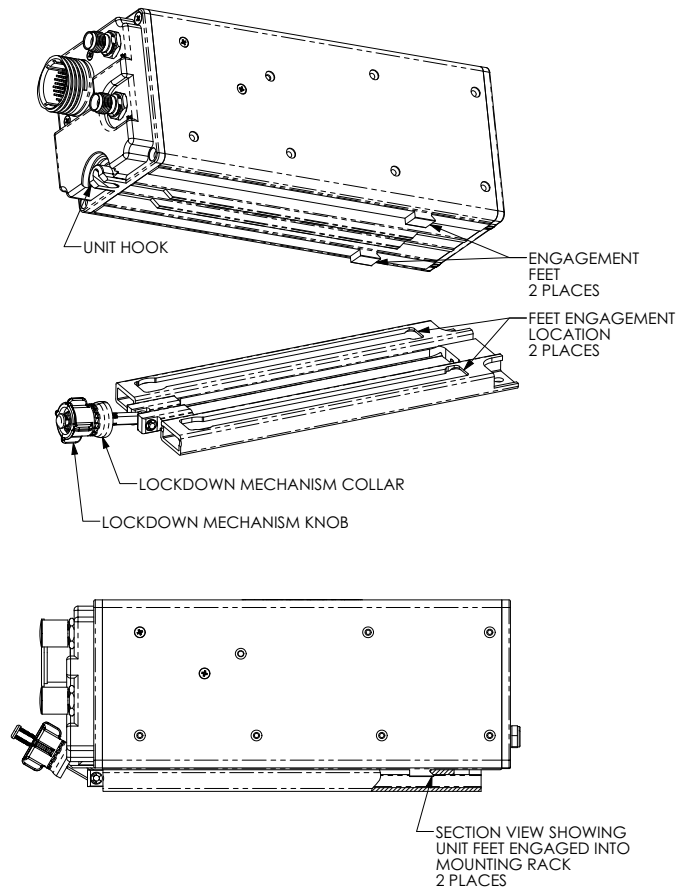

Figure 6-1. GRA 55/5500 Installation

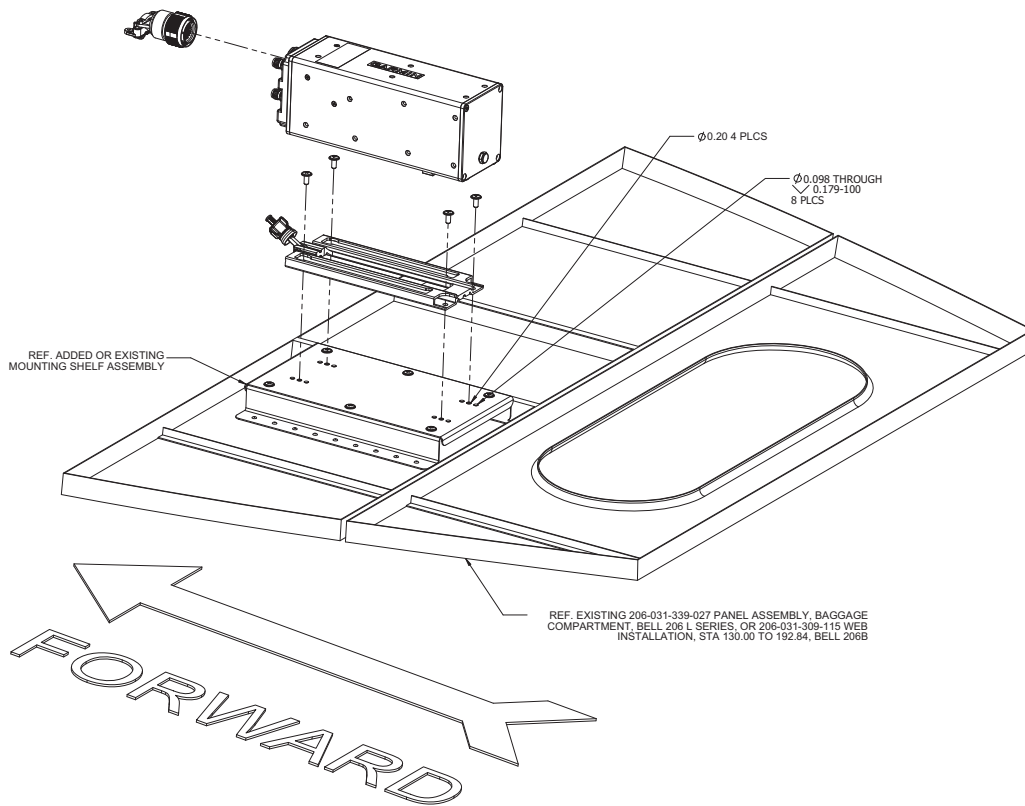

Figure 6-2. Rack Installation

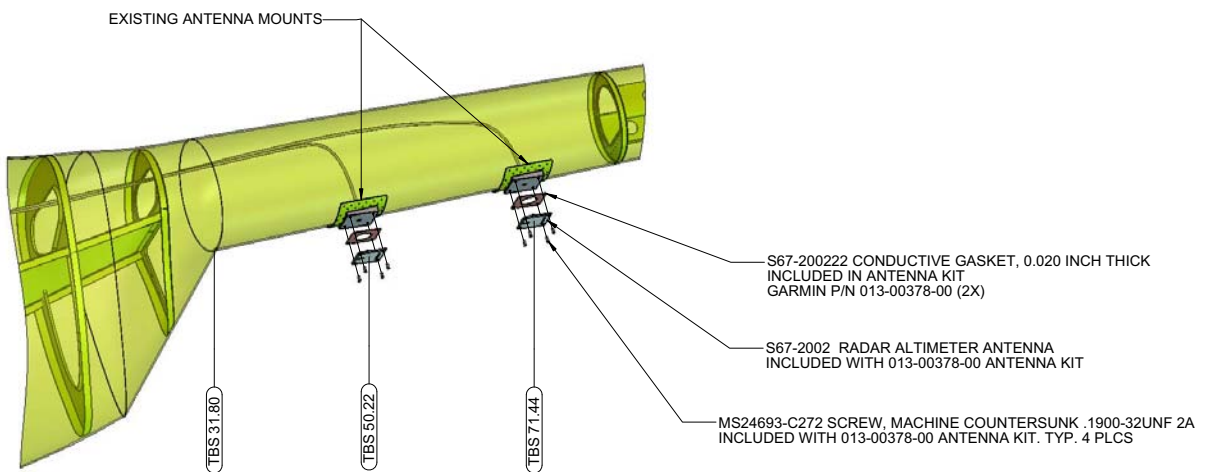

Figure 6-3. GRA 55/5500 Antenna Installation

7 RETURN TO SERVICE PROCEDURE

7.1 Return to Service

1. Perform Zero-Foot Calibration in accordance with Section 3.4.6.
2. Verify no faults exist in the Assert Log page prior to disconnecting Retrofit Installation Tool.
3. Verify that radar altitude is displayed correctly on the installed display with the GRA 55/5500 and display powered on. If radar altitude is not displayed, verify correct configuration.

7.2 Maintenance Records

After conducting required return-to-service procedures in accordance with this document, the aircraft may be returned to service. Record the following information in the aircraft maintenance logs:

1. Software versions loaded as part of any maintenance action.
2. Record part and serial numbers of any LRU that was replaced.
3. Any other applicable information related to the maintenance work performed on the aircraft.

8 LIMITATIONS AND ADDITIONAL REQUIREMENTS

8.1 Diagrams

Aircraft specific LRU locations and wire routing diagram are contained in Appendix A of this document. Completed forms are to be retained with the aircraft permanent records.

Point-to-point wiring diagrams for the GRA 55/5500, and interfaced equipment shall be included with the aircraft permanent records.

GRA 55/5500 component locations are described in Appendix A of this document.

8.2 Special Inspection Requirements

Visual inspection of antenna(s) must be performed if aircraft is suspected or was actually struck by lightning. The scope of inspection shall extend to the GRA 55/5500 antennas and rotorcraft structure supporting antenna installation to verify there is no damage. See Table 4-2 for inspection criteria.

Execute the system checkout procedure for the GRA 55/5500 system to ensure the system is operating correctly.

8.3 Application of Protective Treatments

None. N/A.

8.4 Data Relative to Structural Fasteners

See Table A-1 and Figure A-3 for LRU fastener information. See Figure 6-3 for Antenna fastener information.

8.5 Additional Instructions

None. N/A.

8.6 Overhaul Period

The system does not require overhaul at a specific time period. Power on self-test and continuous BIT will monitor the health of the GRA system. If the LRU indicates an internal failure, the unit may be removed and replaced (See Section 6 for Removal and Installation instructions). See Section 5 for troubleshooting information.

8.7 ICA Revision and Distribution

To revise this ICA, Garmin will follow the Garmin ODA Procedures Manual SOP-0055/ACP-0016 for Instructions for Continued Airworthiness. The latest revision of this ICA document is available on the Garmin website (www.flyGarmin.com). To Access Aviation Manuals, select the 'Support' tab and then select 'Manuals'. You may also contact Garmin General Aviation Product Support at 866-739-5687 (US toll free) 913-397-8200 or avionics@garmin.com. A Garmin Service Bulletin describing ICA revision will be sent to Garmin dealers if a revision is determined to be significant.

8.8 Assistance

Flight Standards Inspectors or the certificate holder's PMI have the required resources to respond to questions regarding this ICA. In addition, the customer may contact Garmin with questions regarding this equipment and its installation. Garmin Customer Support may be contacted during normal business hours via telephone 913-397-8200 or from the Garmin web site at www.flyGarmin.com.

8.9 Implementation and Record Keeping

Modification of an aircraft by this Supplemental Type Certificate obligates the aircraft operator to include the maintenance information provided by this document in the operator's aircraft maintenance manual and/or the operator's rotorcraft scheduled maintenance program.

9. AIRWORTHINESS LIMITATIONS SECTION

The Airworthiness Limitations section is FAA approved and specifies inspections and other maintenance required under §§ 43.16 and 91.403 of the Federal Aviation Regulations unless an alternative program has been FAA approved.

There are no additional Airworthiness Limitations as defined in 14 CFR § 27, Appendix A, A27.4 that result from this modification.

FAA APPROVED

 11-July-2014
Michael Warren Date
ODA STC Unit Administrator
ODA-240087-CE

APPENDIX A AIRCRAFT SPECIFIC INFORMATION

Figure A-1 and Figure A-2 depicts the typical location for the GRA55/5500 component locations.

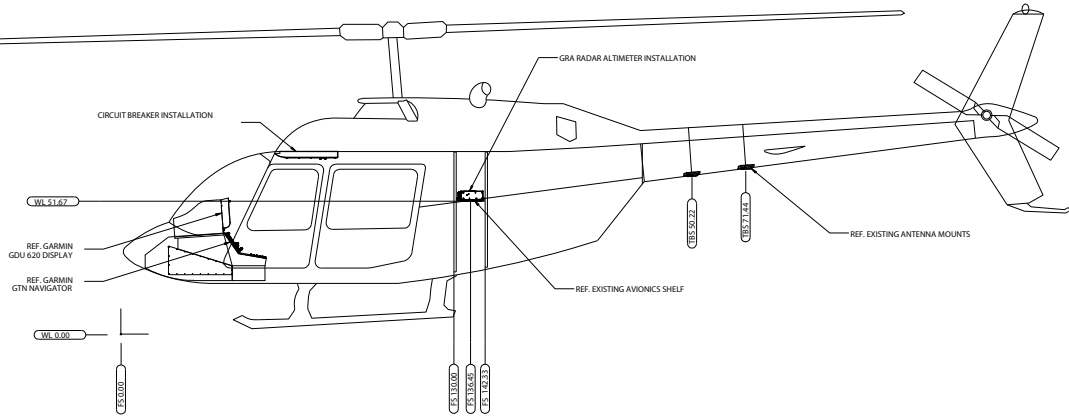

Figure A-1. GRA STC Equipment Fuselage Station Location for Bell 206B

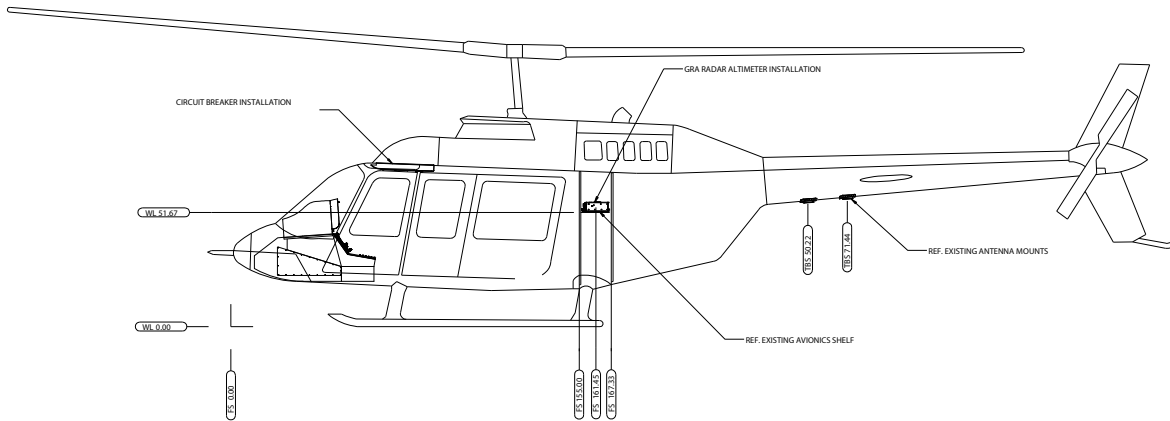

Figure A-2. GRA STC Equipment Fuselage Station Location for Bell 206L Series

Figure A-3 depicts a typical installation of the GRA55/5500 unit and rack installation as performed in the Bell 206B and Bell 206L Series and reference notations to the bill of materials. Table A-1 provides the bill of materials in reference to Figure A-3.

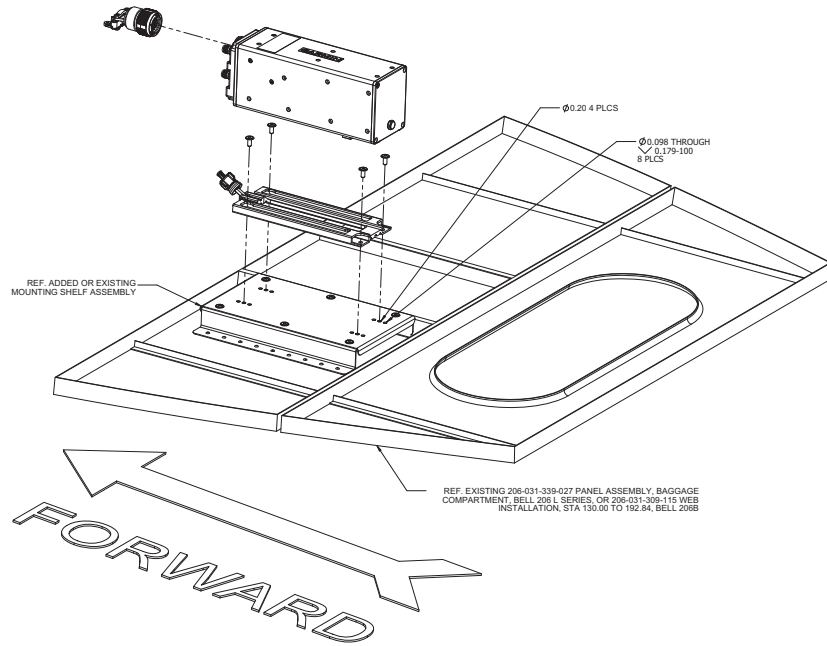

Figure A-3. GRA 55/5500 Unit and Rack Installation in the Bell 206B, 206L Series

Table A-1. Bill of Materials

Item No.	Part Number	Source	Description	QTY
1	011-02537-05	Garmin	GRA 55 Radar Altimeter Unit	(1)
	011-02537-00		GRA 5500 Radar Altimeter Unit	
2	015-2573-01	Garmin	Connector Kit, GRA Radar Altimeter	1
3	015-2567-00	Garmin	Rack, Mounting, GRA Radar Altimeter	1
4	AN525-10R7	Best Source	Screw, Washer Head, 0.1900-32 UNF-3A, 7/16" Long	4
5	MS21047-3	Best Source	Nut, Self-Locking, Plate, Two-Lug, Low-Height, Steel	4
6	MS20470AD3-3	Best Source	Rivet, Solid, Countersunk 100 Deg, Precision Head	8

Figure A-4 depicts the overhead panel location in the Bell 206B, 206L Series.

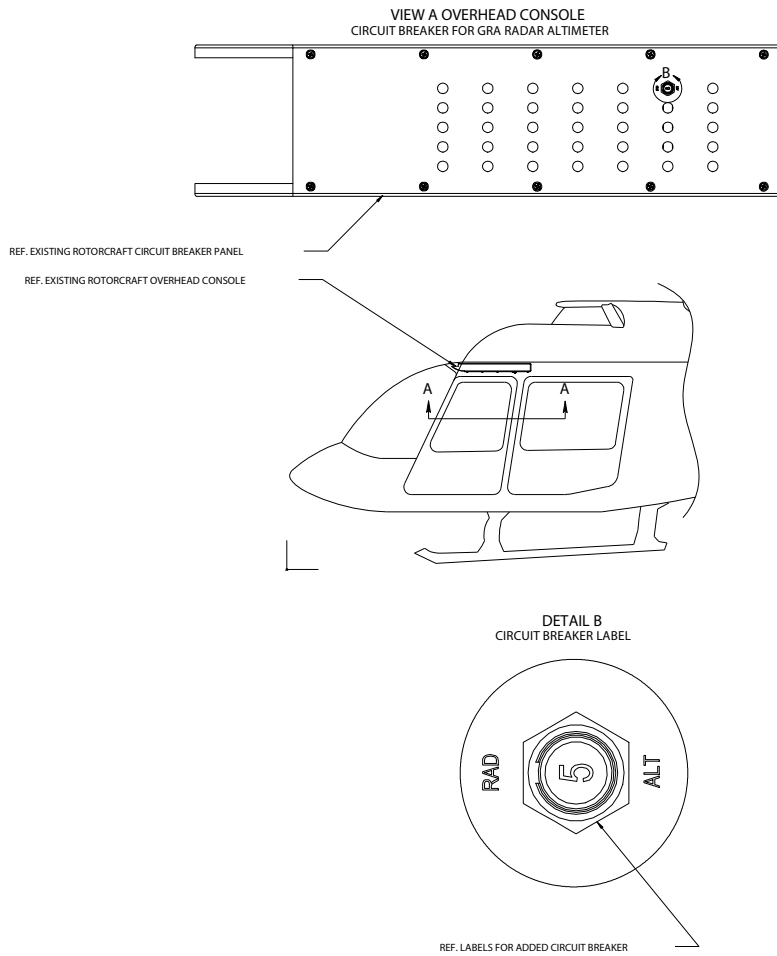

Figure A-4. Overhead Circuit Breaker Panel in Bell 206B, 206L Series

The GRA 55/5500 circuit breaker is located on the Bell 206B and Bell 206L Series overhead circuit breaker console. Equipment circuit breaker placards are labeled as follows:

Table A-2. Circuit Breaker Placard

LRU	Power Input	Label
GRA	Rotorcraft Power on Connector P55001	Rad Alt

Figure A-5 depicts the typical wire harness installation for the GRA 55/5500 system, to include the coaxial cable installation for the antennas. Due to aircraft configurations, minor deviations may exist to the depicted routing. For additional details refer to the GRA 55/5500 installation manual.

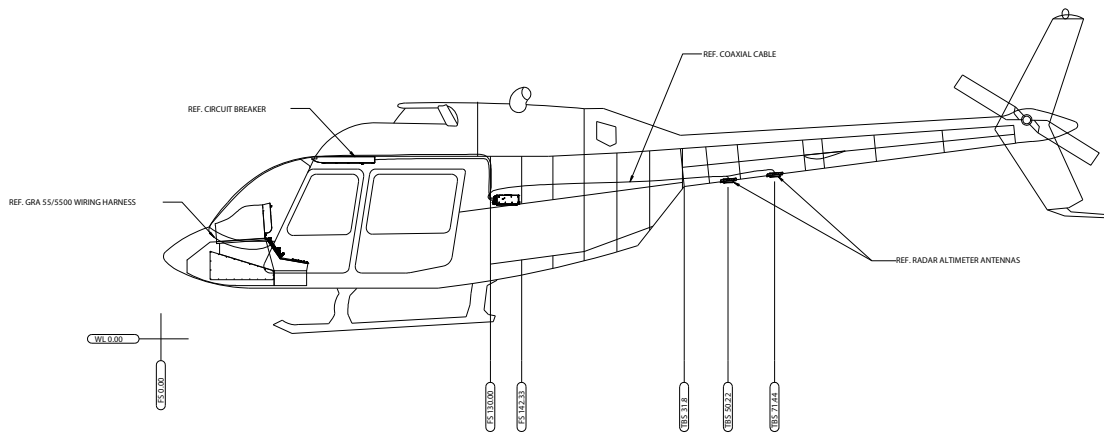

Figure A-5. GRA 55/5500 Wire Routing in the Bell 206B, 206L Series

A.1 Weight and Balance

The location of equipment as well as the weight and moment arm for the installed item is depicted in Figure A-6.

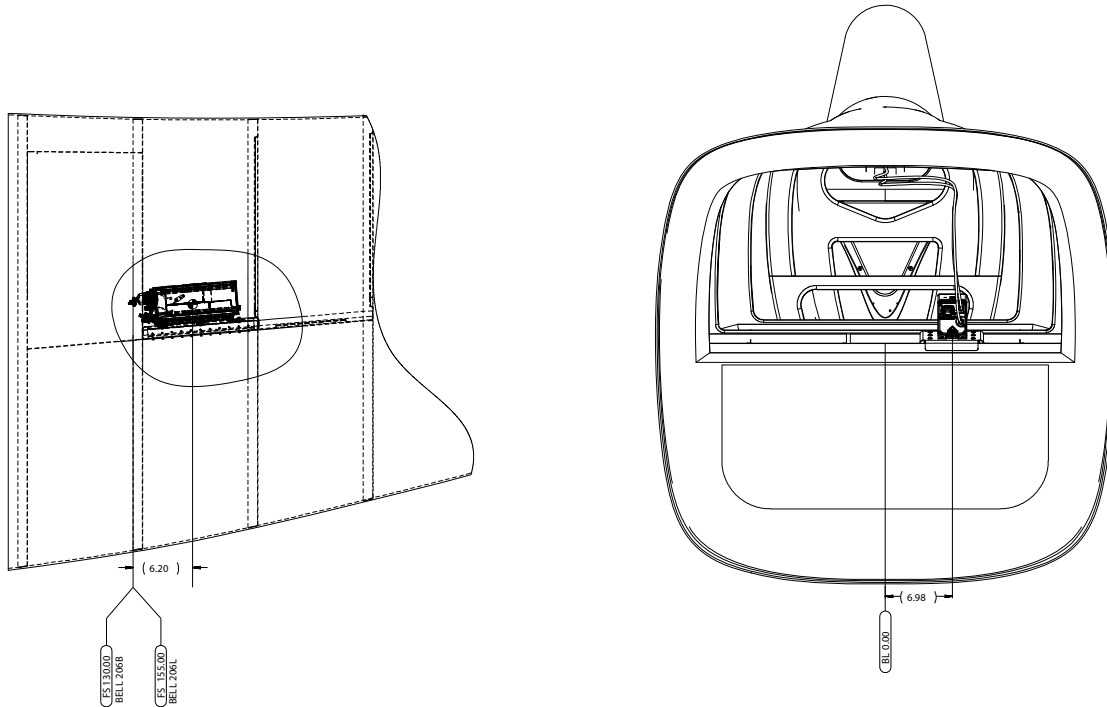

Figure A-6. GRA 55/5500 Unit Location and Moment Arm in Bell 206B, 206L Series

Table A-3. Weight and Balance Details

Item	Description	Part Number	Weight (LB)	Longitudinal		Lateral	
				ARM (IN)	Moment	ARM (IN)	Moment
1	GRA 55 Radar Altimeter (Bell 206B)	011-02537-05	3.5 [1]	136.20	476.70	-6.98	-24.43
2	GRA 5500 Radar Altimeter (Bell 206B)	011-02537-00	3.5 [1]				
3	GRA 55 Radar Altimeter (Bell 206L Series)	011-02537-05	3.5 [1]	161.20	564.20	-6.98	-24.43
4	GRA 5500 Radar Altimeter (Bell 206L Series)	011-02537-00	3.5 [1]				

[1] Weight specified includes the unit, install rack, and backplate assembly with connectors.

Figure A-7 depicts the location of the LRUs and antennas for the GRA 55/5500 throughout the aircraft structure for the Bell 206B rotorcraft. All harnesses fabricated as part of this STC follow existing wire bundles as depicted in Figure A-5.

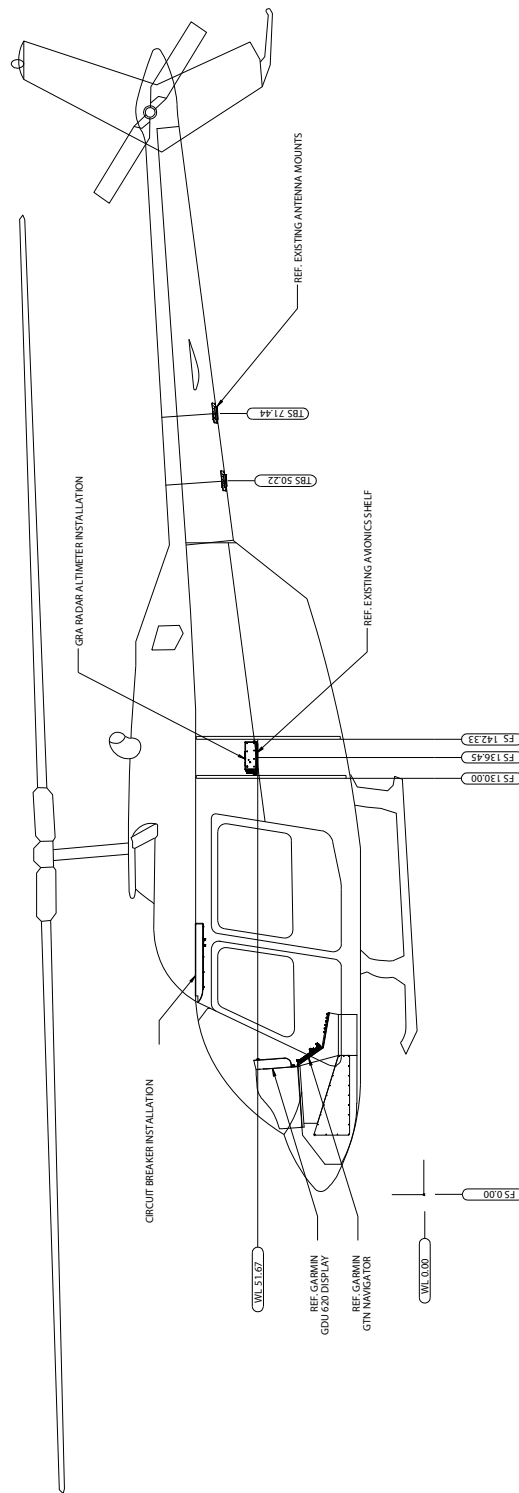

Figure A-7. Bell 206B LRU and Antenna Locations

Figure A-8 depicts the location of the LRUs and antennas for the GRA 55/5500 throughout the aircraft structure for the Bell 206L Series rotorcraft. All harnesses fabricated as part of this STC follow existing wire bundles as depicted in Figure A-5.

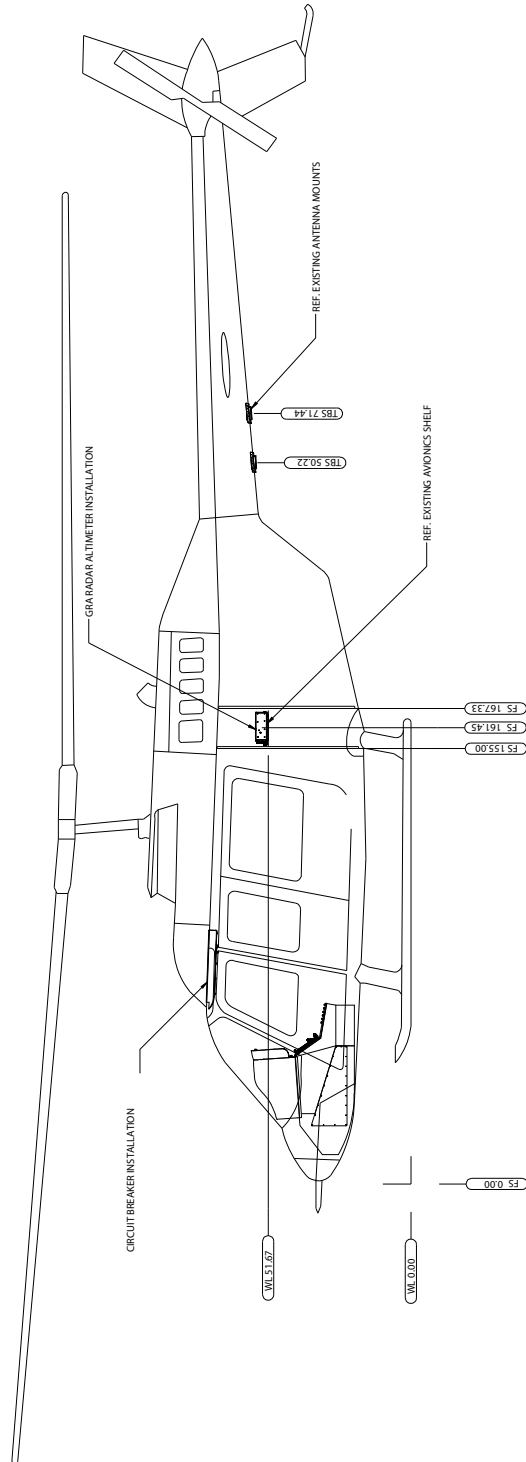

Figure A-8. Bell 206L Series LRU and Antenna Locations

GARMIN  **®**