

Rev	Discription of Changes
1	Original Print

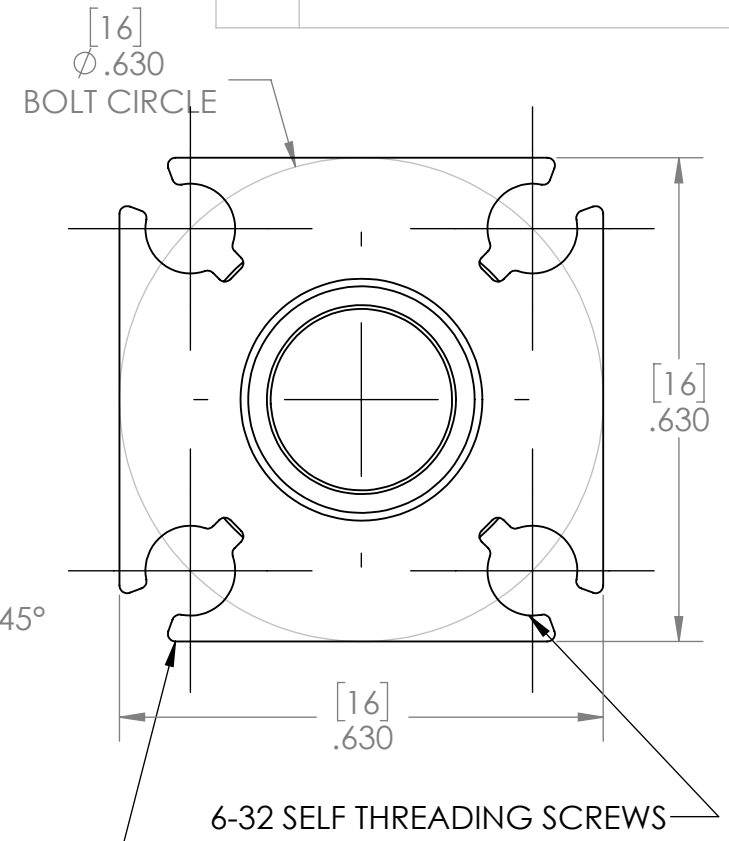

ex-3215 EXTRUSION

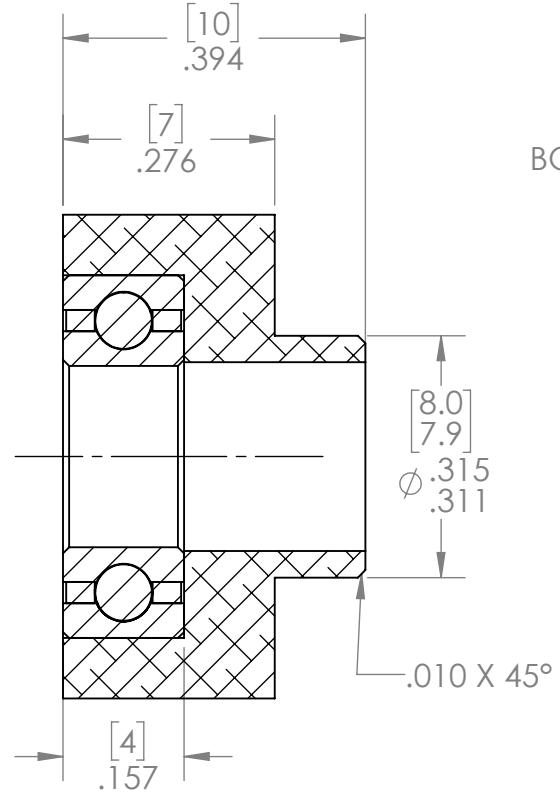
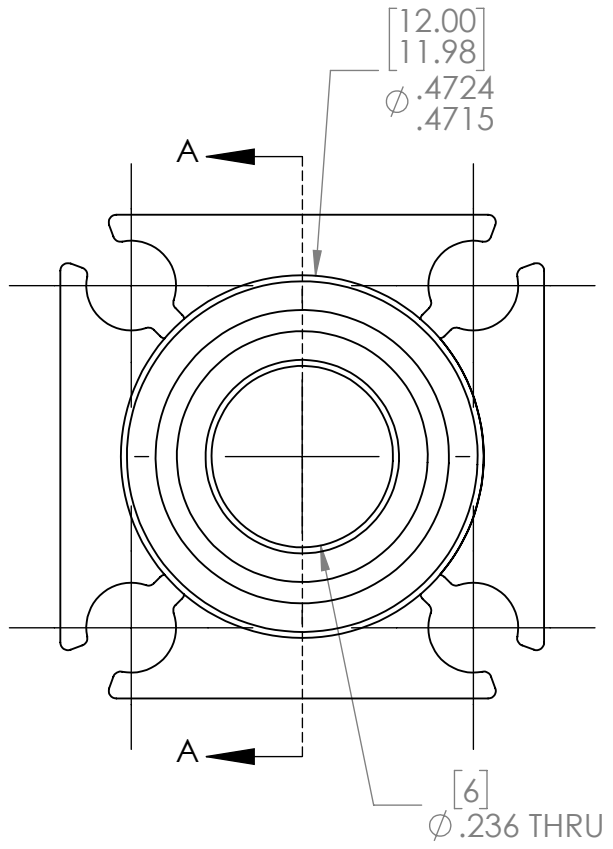
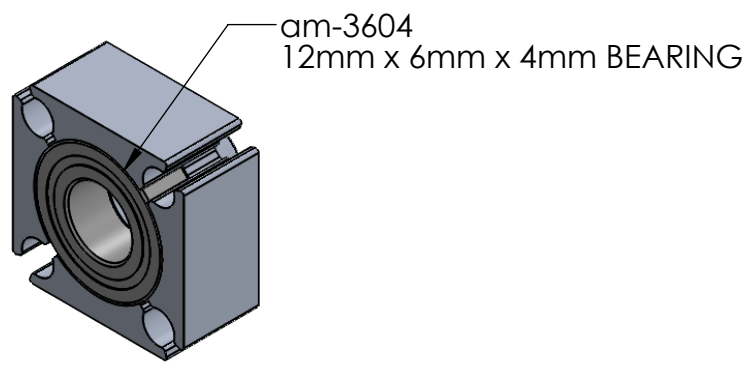

\*SEE CAD FOR ADDITIONAL GEOMETRY\*

UNLESS OTHERWISE SPECIFIED:		NAME	DATE
DIMENSIONS ARE IN INCHES		DRAWN	TN 7/27/17
TOLERANCES:		CHECKED	
FRACTIONAL $\pm 1/32$		ENG APPR.	TN 7/31/17
ANGULAR: MACH $\pm 1^\circ$ BEND $\pm 5^\circ$		MFG APPR.	
ONE PLACE DECIMAL $\pm 0.100$		Q.A.	
TWO PLACE DECIMAL $\pm 0.010$		COMMENTS:	
THREE PLACE DECIMAL $\pm 0.005$		Dual dimensions are in millimeters	
INTERPRET GEOMETRIC TOLERANCING PER:			
MATERIAL			
6061-T6 ALUMINUM			
FINISH			
DEBURRED			
DO NOT SCALE DRAWING			



TITLE:  
**SINGLE BEARING NUB**

SIZE	DWG. NO.	REV
<b>A</b>	<b>am-3667</b>	<b>1</b>
SCALE: 4:1	WEIGHT:	SHEET 1 OF 1