



SEW
EURODRIVE

Operating Instructions



Frequency Inverters
MOVITRAC® LTE-B+



Contents

1 General information..... 7

1.1 About this documentation 7

1.2 Structure of the safety notes 7

 1.2.1 Meaning of signal words 7

 1.2.2 Structure of section-related safety notes..... 7

 1.2.3 Structure of embedded safety notes 8

1.3 Rights to claim under limited warranty 8

1.4 Product names and trademarks..... 8

1.5 Copyright notice 8

2 Safety notes 9

2.1 Preliminary information 9

2.2 Duties of the user..... 9

2.3 Target group 10

2.4 Designated use 11

 2.4.1 Lifting applications..... 11

 2.4.2 Restrictions under the European WEEE Directive 2012/19/EU 11

2.5 Transport..... 11

2.6 Installation/assembly..... 12

2.7 Restrictions of use 12

2.8 Electrical installation 13

 2.8.1 Required preventive measure 13

 2.8.2 Stationary application 13

2.9 Protective separation 13

2.10 Startup/operation 14

3 Device structure 15

3.1 Nameplate..... 15

3.2 Type designation..... 15

3.3 Device structure of the standard inverter 16

 3.3.1 Inverters with degree of protection IP20/NEMA 1 16

 3.3.2 Inverters with degree of protection IP66/NEMA 4X..... 17

4 Installation..... 18

4.1 General information 18

4.2 Permitted tightening torques 19

4.3 Mechanical installation 19

 4.3.1 IP20 housing: Installation and installation space 19

 4.3.2 IP66 housing: Installation and control cabinet dimensions 21

4.4 Electrical installation 22

 4.4.1 Before installation..... 23

 4.4.2 Line contactors..... 23

 4.4.3 Mains fuses 24

 4.4.4 Residual current device..... 24

 4.4.5 Operation on IT system..... 25

 4.4.6 Permitted voltage supply systems..... 27

29135451/EN – 01/2020

4.4.7	Help card	27
4.4.8	Opening the front cover	27
4.4.9	Connecting and installing the braking resistor	28
4.4.10	Motor temperature protection TF, TH	29
4.4.11	Multi-motor drive/group drive	30
4.4.12	Connecting AC brakemotors	30
4.4.13	Information Regarding UL	31
4.4.14	Electromagnetic compatibility (EMC)	32
4.4.15	Overview of signal terminals	36
4.4.16	Communication socket RJ45	38
4.4.17	DC link connection, U _z connection	38
4.4.18	Wiring diagram	38
4.4.19	Brake control	40
5	Startup	41
5.1	User interface	41
5.1.1	Keypads	41
5.1.2	Resetting parameters to default settings	42
5.1.3	Software LT Shell	43
5.1.4	MOVITOOLS® MotionStudio engineering software	45
5.2	"Auto tune" automatic measuring procedure	47
5.3	Startup for motors	47
5.3.1	Startup with asynchronous motors with V/f control	47
5.3.2	Startup with asynchronous motors with LVFC speed control	48
5.3.3	Startup with LSPM motors from SEW-EURODRIVE	48
5.3.4	Startup of synchronous motors without encoder feedback (PMVC speed control)	48
5.3.5	Startup with brushless DC motors (BLDC speed control)	50
5.3.6	Startup with synchronous reluctance motors (SYN-R speed control)	50
5.4	Startup of the control signal source	51
5.4.1	Terminal mode (factory setting) P-12 = 0	51
5.4.2	Keypad mode (P-12 = 1 or 2)	52
5.4.3	PI controller mode (P-12 = 9 or 10)	52
5.4.4	Master-slave mode (P-12 = 11)	54
5.4.5	Fieldbus mode (P-12 = 3, 4, 5, 6, 7 or 8)	54
5.5	Fire mode/emergency mode	55
5.6	Operation at 87 Hz characteristic (50 Hz motors)	56
5.7	Fans and pumps	57
5.8	Motor potentiometer	57
5.9	3-wire control	57
5.9.1	Control signal source 3-wire control	58
6	Operation	59
6.1	Status of the inverter	59
6.1.1	Static inverter status	59
6.1.2	Operating state of the inverter	59
6.1.3	Error reset	59

6.2	Troubleshooting	60
6.3	Error history	60
6.4	Error list.....	61
7	Fieldbus mode	65
7.1	General information	65
7.1.1	Structure and settings of process data words	65
7.1.2	Communication example.....	67
7.1.3	Parameter settings for the inverter	67
7.1.4	Connecting the signal terminals at the inverter	67
7.1.5	Establishing a CANopen/SBus network	68
7.2	Connecting a gateway or controller (SBus MOVILINK®)	68
7.2.1	Specification	68
7.2.2	Electrical installation.....	69
7.2.3	Startup at gateway	70
7.3	Modbus RTU.....	70
7.3.1	Specification.....	70
7.3.2	Electrical installation.....	70
7.3.3	Register allocation of the process data words	71
7.3.4	Data flow example.....	72
7.4	CANopen	73
7.4.1	Specification.....	73
7.4.2	Electrical installation.....	73
7.4.3	COB IDs and functions in the inverter.....	74
7.4.4	Supported transmission modes.....	74
7.4.5	Default allocation plan of process data objects (PDO).....	75
7.4.6	Data flow example.....	76
7.4.7	Emergency code objects.....	76
7.4.8	Table of CANopen-specific objects	77
7.4.9	Table of manufacturer-specific objects	78
8	Parameters	79
8.1	Overview of parameters.....	79
8.1.1	Configuration parameters.....	79
8.1.2	Parameters for realtime monitoring (read only).....	79
8.1.3	Basic parameters	82
8.1.4	Advanced parameters	83
8.2	Explanation of the parameters	85
8.2.1	Basic parameters	85
8.2.2	Advanced parameters	89
8.2.3	Configuration parameters.....	112
9	Technical data.....	113
9.1	Marks	113
9.2	Ambient conditions.....	113
9.3	Output power and current carrying capacity without EMC filter	114
9.3.1	1-phase system AC 115 V for 3-phase AC 230 V motors (voltage doubler).....	114

9.4	Output power and current carrying capacity with EMC filter	115
9.4.1	1-phase system AC 230 V for 3-phase AC 230 V motors	115
9.4.2	3-phase system AC 230 V for 3-phase AC 230 V motors	116
9.4.3	3-phase system AC 400 V for 3-phase AC 400 V motors	118
9.5	Input voltage ranges	122
9.6	Speed setting range	122
9.7	Overload capacity	123
9.8	Protection function	123
9.9	Housing variants and dimensions	124
9.9.1	Housing variants	124
9.9.2	Dimensions IP20/NEMA-1 housing	124
9.9.3	Dimensions of IP66/NEMA-4X housings (LTE xxx -30 and -40)	125
10	Service	126
10.1	Electronics Service by SEW-EURODRIVE	126
10.2	Extended storage	126
10.3	Waste disposal	127
11	Address list	128
	Index	139

1 General information

1.1 About this documentation

This documentation is an integral part of the product. The documentation is intended for all employees who perform assembly, installation, startup, and service work on the product.

Make sure this documentation is accessible and legible. Ensure that persons responsible for the machinery and its operation as well as persons who work on the device independently have read through the documentation carefully and understood it. If you are unclear about any of the information in this documentation or require further information, contact SEW-EURODRIVE.

1.2 Structure of the safety notes

1.2.1 Meaning of signal words

The following table shows the grading and meaning of the signal words for safety notes.

Signal word	Meaning	Consequences if disregarded
▲ DANGER	Imminent hazard	Severe or fatal injuries.
▲ WARNING	Possible dangerous situation	Severe or fatal injuries.
▲ CAUTION	Possible dangerous situation	Minor injuries
NOTICE	Possible damage to property	Damage to the drive system or its environment.
INFORMATION	Useful information or tip: Simplifies handling of the drive system.	

1.2.2 Structure of section-related safety notes

Section-related safety notes do not apply to a specific action but to several actions pertaining to one subject. The hazard symbols used either indicate a general hazard or a specific hazard.

This is the formal structure of a safety note for a specific section:



SIGNAL WORD

Type and source of hazard.

Possible consequence(s) if disregarded.

- Measure(s) to prevent the hazard.

1.2.3 Structure of embedded safety notes

Embedded safety notes are directly integrated into the instructions just before the description of the dangerous action.

This is the formal structure of an embedded safety note:

- **▲ SIGNAL WORD** Type and source of hazard.
 - Possible consequence(s) if disregarded.
 - Measure(s) to prevent the hazard.

1.3 Rights to claim under limited warranty

A requirement of fault-free operation and fulfillment of any rights to claim under limited warranty is that you adhere to the information in the documentation. Read the documentation before you start working with the product.

1.4 Product names and trademarks

The brands and product names in this documentation are trademarks or registered trademarks of their respective titleholders.

1.5 Copyright notice

© 2020 SEW-EURODRIVE. All rights reserved. Unauthorized reproduction, modification, distribution or any other use of the whole or any part of this documentation is strictly prohibited.

2 Safety notes

2.1 Preliminary information

The following general safety notes serve the purpose of preventing injury to persons and damage to property. They primarily apply to the use of products described in this documentation. If you use additional components, also observe the relevant warning and safety notes.

2.2 Duties of the user

As the user, you must ensure that the basic safety notes are observed and complied with. Make sure that persons responsible for the machinery and its operation as well as persons who work on the device independently have read through the documentation carefully and understood it.

As the user, you must ensure that all of the work listed in the following is carried out only by qualified specialists:

- Setup and installation
- Installation and connection
- Startup
- Maintenance and repairs
- Shutdown
- Disassembly

Ensure that the persons who work on the product pay attention to the following regulations, conditions, documentation, and information:

- National and regional safety and accident prevention regulations
- Warning and safety signs on the product
- All other relevant project planning documents, installation and startup instructions, and wiring diagrams
- Do not assemble, install or operate damaged products
- All system-specific specifications and conditions

Ensure that systems in which the product is installed are equipped with additional monitoring and protection devices. Observe the applicable safety regulations and legislation governing technical work equipment and accident prevention regulations.

2.3 Target group

Specialist for mechanical work	<p>Any mechanical work may be performed only by adequately qualified specialists. Specialists in the context of this documentation are persons who are familiar with the design, mechanical installation, troubleshooting, and maintenance of the product who possess the following qualifications:</p> <ul style="list-style-type: none"> • Qualification in the mechanical area in accordance with the national regulations • Familiarity with this documentation
Specialist for electrotechnical work	<p>Any electrotechnical work may be performed only by electrically skilled persons with a suitable education. Electrically skilled persons in the context of this documentation are persons who are familiar with electrical installation, startup, troubleshooting, and maintenance of the product who possess the following qualifications:</p> <ul style="list-style-type: none"> • Qualification in the electrotechnical area in accordance with the national regulations • Familiarity with this documentation
Additional qualification	<p>In addition to that, these persons must be familiar with the valid safety regulations and laws, as well as with the requirements of the standards, directives, and laws specified in this documentation.</p> <p>The persons must have the express authorization of the company to operate, program, parameterize, label, and ground devices, systems, and circuits in accordance with the standards of safety technology.</p>
Instructed persons	<p>All work in the areas of transportation, storage, operation and waste disposal must be carried out by persons who are trained appropriately. The purpose of the instruction is to give persons the ability to perform the required tasks and work steps in a safe and correct manner.</p>

2.4 Designated use

The product is intended for installation in electrical plants or machines.

In case of installation in electrical systems or machines, startup of the product is prohibited until it is determined that the machine meets the requirements stipulated in the local laws and directives. For Europe, Machinery Directive 2006/42/EC as well as the EMC Directive 2014/30/EU apply. Observe EN 60204-1 (Safety of machinery - electrical equipment of machines). The product meets the requirements stipulated in the Low Voltage Directive 2014/35/EU.

The standards given in the declaration of conformity apply to the product.

The systems can be mobile or stationary.

The product can be used to operate the following motors in industrial and commercial systems:

- AC asynchronous motors with squirrel-cage rotor

Technical data and information on the connection conditions are provided on the nameplate and in chapter "Technical data" in the documentation. Always comply with the data and conditions.

Unintended or improper use of the product may result in severe injury to persons and damage to property.

Do not use the product as a climbing aid.

2.4.1 Lifting applications

The product may not be used for lifting applications or on slopes.

2.4.2 Restrictions under the European WEEE Directive 2012/19/EU

You may use options and accessories from SEW-EURODRIVE exclusively in connection with products from SEW-EURODRIVE.

2.5 Transport

Inspect the shipment for damage as soon as you receive the delivery. Inform the shipping company immediately about any damage. If the product is damaged, it must not be assembled, installed or started up.

Observe the following notes when transporting the device:

- Ensure that the product is not subject to mechanical impact.
- Before transportation, cover the connections with the supplied protection caps.
- Only place the product on the cooling fins or on the side without connectors during transportation.
- Always use all attachment points if available. The attachment points are designed to carry only the mass of the product. Severe or fatal injuries. Do not apply any additional loads.

If necessary, use suitable, sufficiently dimensioned handling equipment.

Observe the information on climatic conditions in chapter "Technical data" of the documentation.

2.6 Installation/assembly

Ensure that the product is installed and cooled according to the regulations in the documentation.

Protect the product from strong mechanical strain. The product and its mounting parts must never protrude into the path of persons or vehicles. Ensure that components are not deformed and insulation spaces are not changed, particularly during transportation and handling. Electric components must not be mechanically damaged or destroyed.

Observe the notes in chapter Mechanical installation in the documentation.

2.7 Restrictions of use

The following applications are prohibited unless the device is explicitly designed for such use:

- Use in potentially explosive atmospheres
- Use in areas exposed to harmful oils, acids, gases, vapors, dust, and radiation
- Operation in applications with impermissibly high mechanical vibration and shock loads in excess of the regulations stipulated in EN 61800-5-1
- Use at an elevation of more than 4000 m above sea level

The product can be used at altitudes above 1000 m above sea level up to 4000 m above sea level under the following conditions:

- The reduction of the nominal output current and/or the line voltage is considered according to the data in chapter Technical data in the documentation.
- Above 2000 m above sea level, the air and creeping distances are only sufficient for overvoltage class II according to EN 60664. At altitudes above 2000 m above sea level, limiting measures must be taken which reduce the line side overvoltage from category III to category II for the entire system.
- If a protective electrical separation (in accordance with EN 61800-5-1 and EN 60204-1) is required, then implement this outside the product at altitudes of more than 2000 m above sea level.

2.8 Electrical installation

Ensure that all of the required covers are correctly attached after carrying out the electrical installation.

Make sure that preventive measures and protection devices comply with the applicable regulations (e.g. EN 60204-1 or EN 61800-5-1).

2.8.1 Required preventive measure

Make sure that the product is correctly attached to the ground connection.

2.8.2 Stationary application

Necessary preventive measure for the product is:

Type of energy transfer	Preventive measure
Direct power supply	• Ground connection

2.9 Protective separation

The product meets all requirements for protective separation of power and electronics connections in accordance with EN 61800-5-1. To ensure protective separation, all connected circuits must also meet the requirements for protective separation.

2.10 Startup/operation

Observe the safety notes in the chapters "Startup" and "Operation" in the documentation.

Make sure that the present transport protection is removed.

Do not deactivate monitoring and protection devices of the machine or system even for a test run.

Make sure the connection boxes are closed and screwed before connecting the supply voltage.

Depending on the degree of protection, products may have live, uninsulated, and sometimes moving or rotating parts, as well as hot surfaces during operation.

Additional preventive measures may be required for applications with increased hazard potential. You have to check the protection devices after each modification.

When in doubt, switch off the product whenever changes occur in relation to normal operation. Possible changes are, e.g., increased temperatures, noise, or oscillation. Determine the cause. Contact SEW-EURODRIVE if necessary.

When the device is switched on, dangerous voltages are present at all power connections as well as at any connected cables and terminals. This also applies even when the product is inhibited and the motor is at standstill.

Do not separate the connection to the product during operation.

This may result in dangerous electric arcs damaging the product.

If you disconnect the product from the voltage supply, do not touch any live components or power connections because capacitors might still be charged. Observe the following minimum switch-off time:

10 minutes.

Observe the corresponding information signs on the product.

The fact that the operation LED and other display elements are no longer illuminated does not indicate that the product has been disconnected from the supply system and no longer carries any voltage.

Mechanical blocking or internal safety functions of the product can cause a motor standstill. Eliminating the cause of the problem or performing a reset may result in the drive re-starting automatically. If, for safety reasons, this is not permitted for the drive-controlled machine, first disconnect the product from the supply system and then start troubleshooting.

Risk of burns: The surface temperature of the product can exceed 60 °C during operation.

Do not touch the product during operation.

Let the product cool down before touching it.

3 Device structure

3.1 Nameplate

The following figure shows an example of a nameplate.

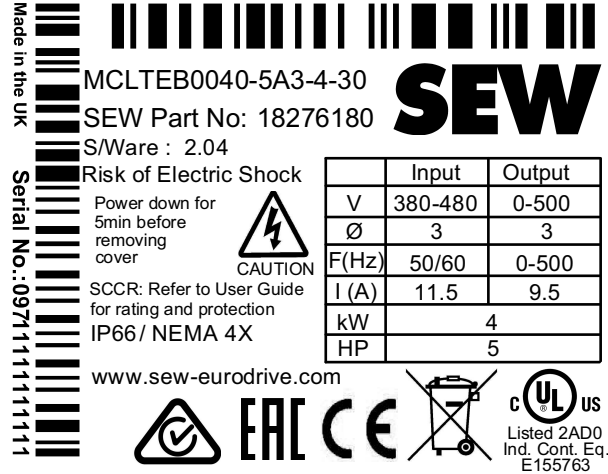

27021611243770379

3.2 Type designation

Example: MCLTE-B 0015-2B1-1-00		
Product name	MCLTE	MOVITRAC® LTE-B
Version	B	Version status of the device series
Recommended motor power	0015	0015 = 1.5 kW
Connection voltage	2	<ul style="list-style-type: none"> 1 = 110 – 115 V 2 = 200 – 240 V 5 = 380 – 480 V
Interference suppression on the input	B	<ul style="list-style-type: none"> 0 = Device without filter (no interference suppression) A = C2 B = C1
Connection type	1	<ul style="list-style-type: none"> 1 = 1-phase 3 = 3-phase
Quadrants	1	<ul style="list-style-type: none"> 1 = 1-quadrant operation without brake chopper 4 = 4-quadrant operation with brake chopper
Design	00	<ul style="list-style-type: none"> 00 = Standard IP20 housing 30 = IP66/NEMA-4X housing without switch 40 = IP66/NEMA-4X housing with switch
Country-specific variant	(60 Hz)	60 Hz = 60 Hz design

29135451/EN – 01/2020

3.3 Device structure of the standard inverter

3.3.1 Inverters with degree of protection IP20/NEMA 1

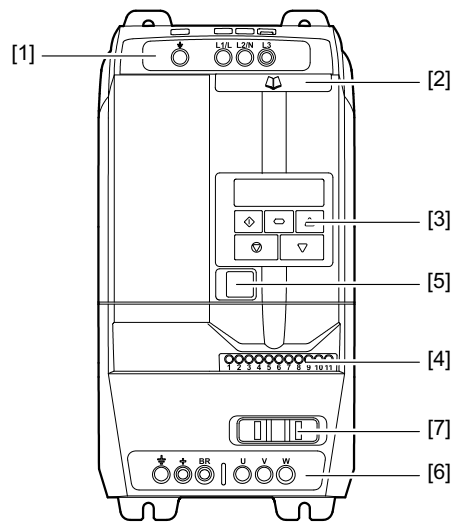

21435655947

- [1] Connecting terminal strip PI, L1/L, L2/N, L3
- [2] Auxiliary card with terminal assignment and basic parameters
- [3] Keypad with a 6-digit 7-segment display
- [4] Control terminal strip
- [5] RJ45 communication socket
- [6] Connecting terminal strip PI, +, BR, U, V, W
(with BG1 no +- and BR connection available)
- [7] Tab for fastening the control cable

3.3.2 Inverters with degree of protection IP66/NEMA 4X

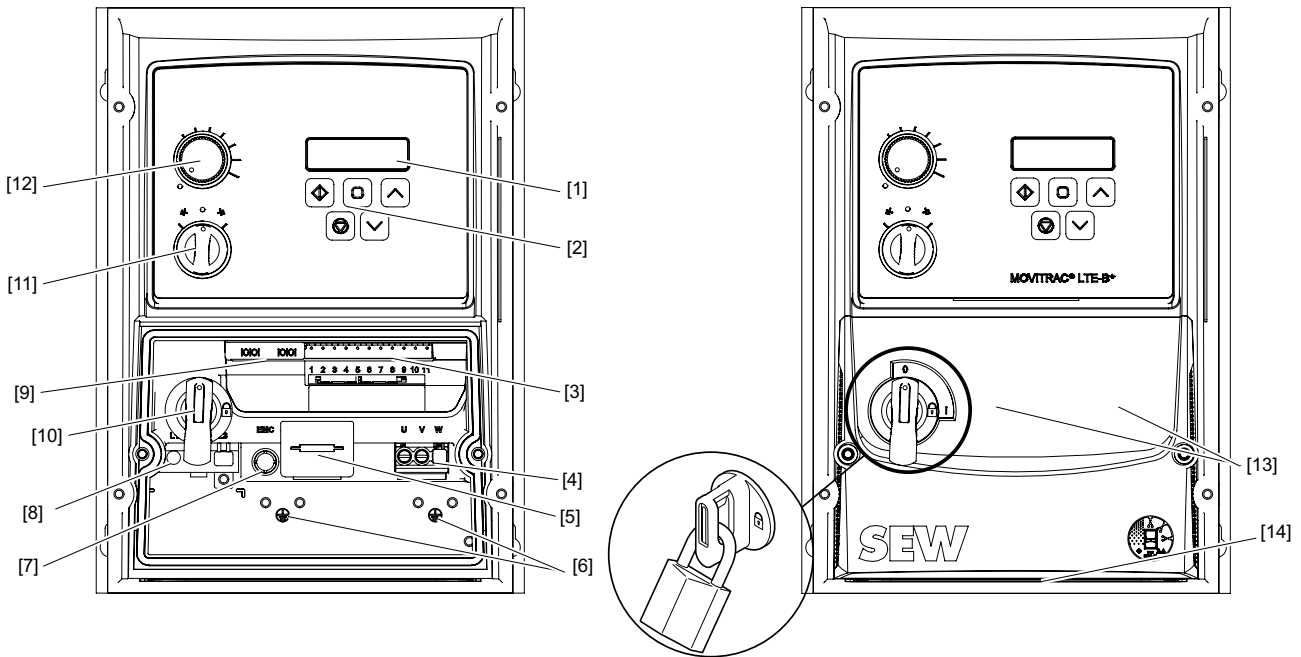

9007220690401931

- [1] 6-digit 7-segment display
- [2] Keypad
- [3] Control terminal strip
- [4] Connecting terminal strip U, V, W
- [5] Connecting terminal strip, braking resistor +, BR (not in size 1)
- [6] PI connections
- [7] EMC screw
- [8] Connecting terminal strip L1/L, L/N, L3
- [9] RJ45 communication socket (dual implementation)

The following points are available only in the device design with switch option.

- [10] Main switch for supply system separation (main switch is lockable)
- [11] Rotary switch direction of rotation CW/0/CCW
- [12] Rotary potentiometer speed

Optional, customer-specific extension of the front cover:

The front cover of the terminal space [13] can be expanded with two additional buttons or switches. For this purpose, it is necessary to drill holes in the cover. The position of these bore holes is marked with punching on the rear side.

The front cover of the terminal space can be extended at the bottom with three additional screw fittings. For this purpose, it is necessary to drill holes in the cover. The position of these bore holes [14] is marked with punching on the underside.

4 Installation

4.1 General information

- Carefully check the frequency inverter for damage before installation.
 - Store the frequency inverter in its original packaging until it is used. The storage location must be clean and dry with an ambient temperature between $-40\text{ }^{\circ}\text{C}$ and $+60\text{ }^{\circ}\text{C}$.
 - Install frequency inverter in a suitable housing on a level, vertical, non-flammable, and vibration-free surface. If a certain IP degree of protection is required, observe EN 60529.
 - Keep flammable materials away from the frequency inverter.
 - Prevent the ingress of conductive or flammable foreign objects.
 - The relative humidity must be kept below 95 % (condensation is not permitted).
 - Protect the IP66 frequency inverter from direct sunlight. Use a cover when using the inverter outdoors.
 - Frequency inverters can be installed next to each other. Ensure sufficient ventilation space between the individual devices. If the frequency inverter is to be installed above another frequency inverter or another device that dissipates heat, then there must be a vertical minimum clearance of 150 mm. To enable self-cooling, the control cabinet must either be cooled through forced ventilation, or dimensioned accordingly. See chapter "IP20 housing: Installation and installation space" (\rightarrow 19).
 - The permitted ambient temperatures are defined in chapter "Ambient conditions" (\rightarrow 113).
 - The mounting rail installation is only possible for the following inverters with degree of protection IP20.
 - 115 V: 0.37 – 1.1 kW
 - 230 V: 0.37 – 2.2 kW
 - 400 V: 0.75 – 4 kW
- The mounting rail must have the dimensions $35 \times 15\text{ mm}$ or $35 \times 7.5\text{ mm}$ and be designed in accordance with EN 50022.
- Install the frequency inverter only as depicted in the following figure:

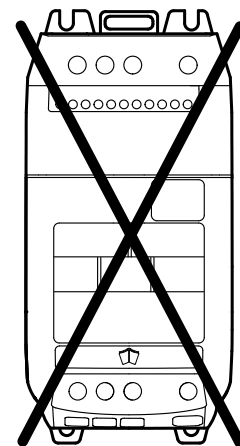
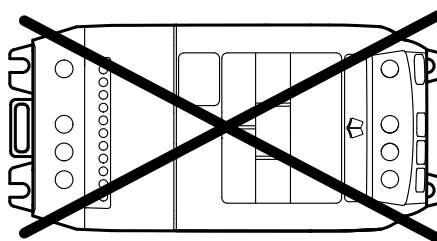
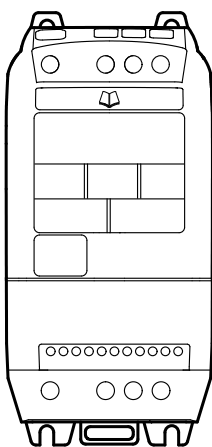

9007206567363979

4.2 Permitted tightening torques

Power of the inverters in kW	Tightening torque in Nm	
	Control terminals	Power terminals
Nominal line voltage 115 V		
0.37 – 1.1	0.5	1
Nominal line voltage 230 V		
0.37 – 5.5	0.5	1
7.5 – 11		15
15 – 18.5		20
Nominal line voltage 400 V		
0.75 – 11	0.5	1
15 – 22		15
30 – 37		20

4.3 Mechanical installation

4.3.1 IP20 housing: Installation and installation space

Inverters with degree of protection IP20 must be installed in a control cabinet. Observe the following requirements:

- The control cabinet must be made of a heat conductive material unless it has forced cooling.
- When using a control cabinet with ventilation openings, the openings must be provided above and underneath the inverter to allow for unobstructed circulation of air. The air must be supplied underneath the inverter and dissipated above it.
- If the inverter is operated in environments with particles of dirt (such as dust), ventilation openings either have to be equipped with a suitable particle filter or forced cooling has to be used. The filter has to be serviced and cleaned.
- In environments with a high level of humidity, salt or chemicals, a suitable enclosed control cabinet (without ventilation openings) must be used.
- The inverters with degree of protection IP20 can be installed right next to each other without clearance.

4 Installation

Mechanical installation

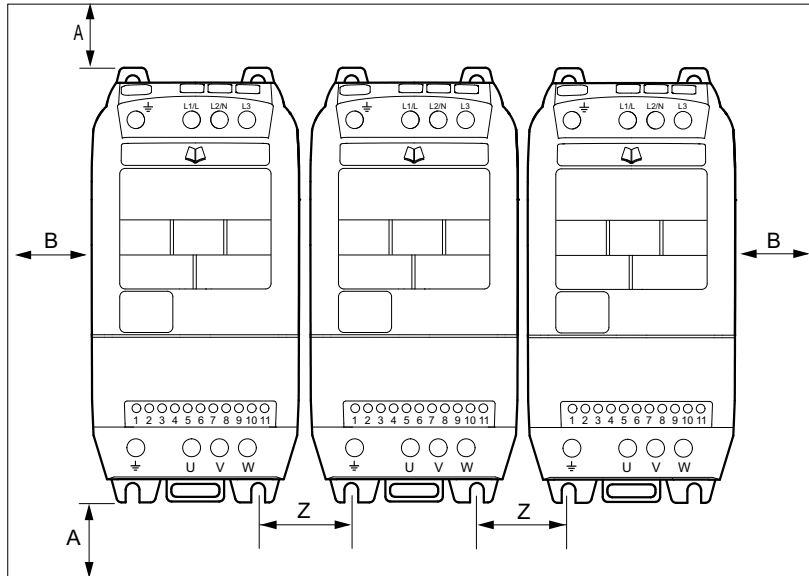

18014410447944843

INFORMATION



The dimension "Z" does not refer to the distance between the inverters, but the distance between the installation holes.

Size	A	B	Z
	mm	mm	mm
1	50	50	33
2	75	50	47
3	100	50	52
4	100	50	34
5	100	50	46

4.3.2 IP66 housing: Installation and control cabinet dimensions

Inverters with degree of protection IP66 can be used indoors.

In control cabinets or in the field, the following minimum distances must not be maintained.

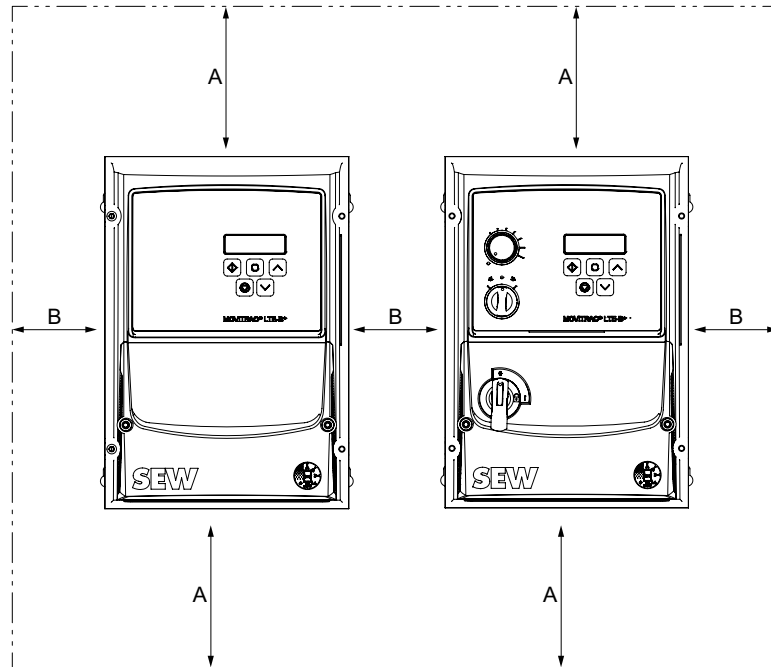

9007220690852619

Size	A	B
	mm	mm
1	200	10
2	200	10
3	200	10

INFORMATION



If the IP66 inverter is installed in a control cabinet, sufficient control cabinet ventilation must be ensured.

4.4 Electrical installation





▲ WARNING

Electric shock due to charged capacitors. Dangerous voltage levels may still be present inside the device and at the terminals up to 10 minutes after disconnection from the power supply.

Severe or fatal injuries.

- Wait 10 minutes after you have de-energized the inverter and have switched off the line voltage and the DC 24 V voltage. Do not start working on the device until you have made sure that it is de-energized.
- The inverters may only be installed by electrical specialists in compliance with the applicable directives and regulations.
- The grounding cable must be designed for the maximum fault current of the voltage source that is usually limited by fuses or motor protection switches.
- The inverter has IP20 degree of protection. For a higher IP degree of protection, a suitable enclosure or the IP66/NEMA 4X design has to be used.
- Make sure the devices are properly grounded. Observe the wiring diagram in chapter "Wiring diagram" (→ 38).

4.4.1 Before installation

- Make sure that the supply voltage, frequency, and number of phases (single- or three-phase) correspond with the nominal values of the inverter on delivery.
- A disconnecting switch or similar disconnecting element must be installed between the voltage supply and the inverter.
- Never connect the power supply to the output terminals U, V, or W of the inverter.
- Do not install contactors between the inverter and the motor. Adhere to a minimum clearance of 100 mm at points where control cables and electric power lines are installed close to each other, and an angle of 90° for crossing cables.
- The cables are only protected by slow-blow high-power fuses or a motor circuit breaker. For more information, refer to section Permitted voltage supply systems.
- It is recommended that you use a 4-core PVC-insulated and shielded cable as the motor cable. Route this cable in accordance with the applicable national regulations of the industrial sector, as well as the applicable rules and standards. Conductor end sleeves are required for connecting the motor cable to the inverter.
- Make sure that shieldings and sheaths of the motor cable are designed according to the wiring diagram in section "General information about connecting the motor shield" (→  33).
- The grounding terminal of each inverter must be connected individually and **directly** to the ground rail (mass) of the installation site (via filter, if available).
- Do not loop the ground connections of the inverter from one inverter to the other. Neither route the ground connections to the inverters from other inverters.
- The impedance of the ground circuit must comply with the local safety regulations of the industrial sector.
- Make sure that all terminals are tightened with the respective tightening torque; see chapter "Permitted tightening torques" (→  19).
- To comply with UL regulations, all earth connections must be designed with UL-listed crimping cable lugs.

Unlike direct operation in the supply system, inverters on the motor generate suitable fast-switching output voltages (PWM). In the case of motors wound for operation with adjustable-speed drives, no further preventive actions are necessary. If, however, the insulation quality is unknown, contact the manufacturer of the motor because preventive actions may be necessary.

INFORMATION



Make sure that the earth connections are properly connected. The inverter can generate leakage currents > 3.5 mA. The grounding cable must be sufficiently dimensioned to carry the maximum error current of the voltage source that is usually limited by fuses or miniature circuit breakers.

Sufficiently rated fuses or miniature circuit breakers must be integrated into the inverter's mains supply in accordance with local laws and/or regulations.

4.4.2 Line contactors

Use only line contactors in utilization category AC-3 (EN 60947-4-1).

Make sure that you wait at least 30 seconds between 2 switching cycles.

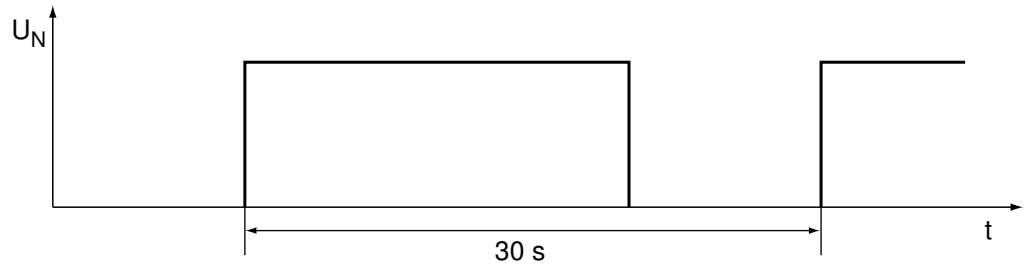

18442995979

4.4.3 Mains fuses

Fuse types:

- Line protection types in operation classes gL, gG:
 - Nominal fusing voltage \geq nominal line voltage
 - The nominal fusing current must be designed for at least 100% of the inverter nominal input current depending on the inverter utilization.
- Power circuit breaker with characteristics B, C:
 - Nominal circuit breaker voltage \geq nominal line voltage
 - The nominal currents of the power circuit breakers must be 10% higher than the nominal inverter current.

4.4.4 Residual current device



⚠ WARNING

No protection against electric shock if an incorrect type of residual current device is used.

Severe or fatal injuries.

- The product can cause direct current in the PE conductor. If a residual current device (RCD) or a residual current monitoring device (RCM) is used for protection in the event of a direct or indirect contact, only a type B RCD or RCM is permitted on the supply end of the product.
- Inverters generate a DC current component in the leakage current and can significantly reduce the sensitivity of a residual current device of type A. A type A residual current device is therefore not permitted as a protection device.
- If the use of a residual current device is not mandatory according to the standards, SEW-EURODRIVE recommends not to use a residual current device.

4.4.5 Operation on IT system

▲ WARNING



Danger of electric shock. Dangerous voltage levels may still be present inside the unit and at the terminals up to 10 minutes after disconnection from the power supply.

Severe or fatal injuries.

- Disconnect the frequency inverter from the power supply at least 10 minutes before you unscrew the EMC screw.

To operate a MOVITRAC® LTE-B+ device on the IT system, the integrated EMC filter must be deactivated.

IP20 devices:

- On sizes 1 – 3, unscrew the EMC screw on the side of the device.

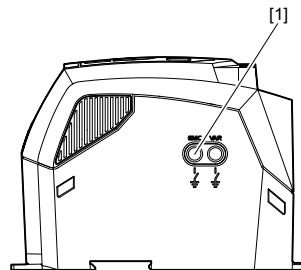

9007216765938315

[1] EMC screw

- On sizes 4 – 5, unscrew the EMC screws at the marked points.

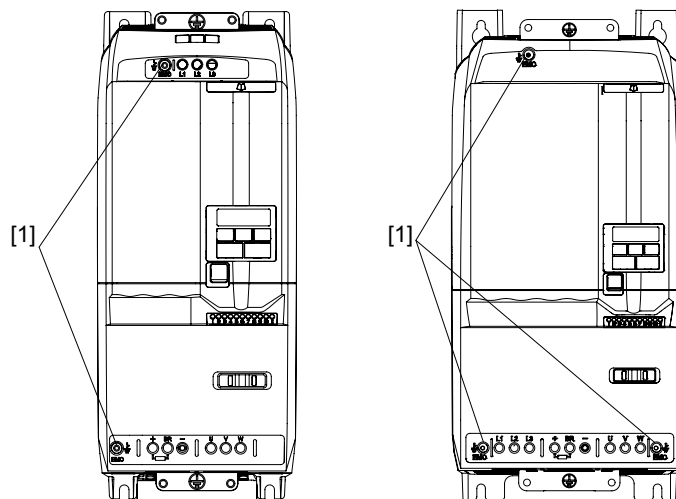

30696952331

[1] EMC screw

IP66 devices:

- On sizes 1 – 3, unscrew the EMC screw in the terminal connection under the cover.

4 Installation

Electrical installation

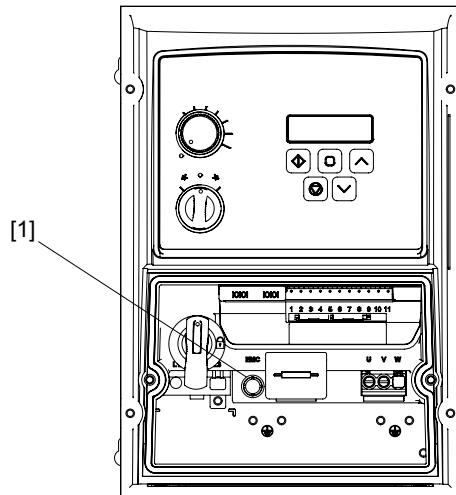

30696962059

[1] EMC screw

SEW-EURODRIVE recommends using earth-leakage monitors with pulse code measurement in voltage supply systems with a non-grounded star point (IT systems). The use of such devices prevents the earth-leakage monitor mis-tripping due to the earth capacitance of the frequency inverter.

4.4.6 Permitted voltage supply systems

- **Voltage supply systems with grounded star point**

Inverters with all degrees of protection are intended for operation on TN and TT systems with a directly grounded star point.

- **Voltage supply systems with non-grounded star point**

Inverters with all degrees of protection can be used on supply systems with a non-grounded star point (e.g. IT systems). The devices must be converted accordingly prior to electrical installation. See chapter "Operation on IT system" (→ 25).

- **Voltage supply systems with grounded outer conductor**

The inverters with all degrees of protection may only be operated on voltage supply systems with a maximum phase-to-ground AC voltage of 300 V.

4.4.7 Help card

The help card contains an overview of the terminal assignment and additionally an overview of the basic parameters of parameter group 1.

In the IP66 housing, the help card is attached behind the removable front cover.

In the IP20 housing, the help card is inserted in a slot above the display.

4.4.8 Opening the front cover

INFORMATION



The front cover must be closed during operation for thermal reasons.

IP66 for all sizes

Remove the 2 screws on the inverter front to open the front cover.

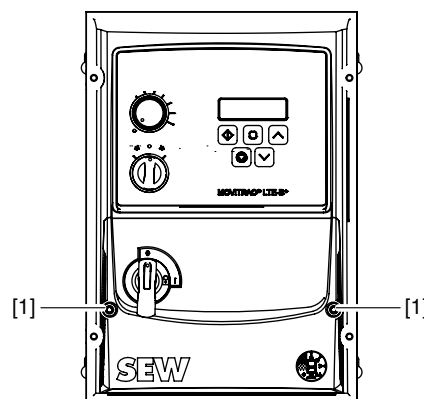

9007202188125195

[1] Screws of the front cover

4.4.9 Connecting and installing the braking resistor

**▲ WARNING**

Danger of electric shock. The supply cables to the braking resistors carry a high voltage (approx. DC 900 V) during rated operation.

Severe or fatal injuries.

- Before removing the supply cable, disconnect the inverter from the power supply and wait at least 10 minutes.

**▲ CAUTION**

Risk of burns. The surfaces of the braking resistors reach high temperatures when a load of P_N is applied.

Minor injuries.

- Choose a suitable installation location.
- Do not touch the braking resistors.
- Install a suitable touch guard.

The braking resistor is connected between the inverter terminals "BR" and "+". In the case of a new device, these terminals have covers installed that can be broken out. Break out the covers prior to first use.

- Shorten the cables to the required length.
- Use 2 tightly twisted leads or a 2-core shielded power cable. The cable cross section has to be dimensioned according to the tripping current I_F of F16 and the nominal voltage in accordance with DIN VDE 0298.
- Protect the braking resistor with a bimetallic relay and set the tripping current I_F of the respective braking resistor.
- The flatpack resistors have internal thermal overload protection (fuse cannot be replaced). Install the flatpack resistors using appropriate touch guards.
- For braking resistors in the BW...-...-T series, you can connect the integrated temperature sensor using a 2-core, shielded cable as an alternative to a bimetallic relay.

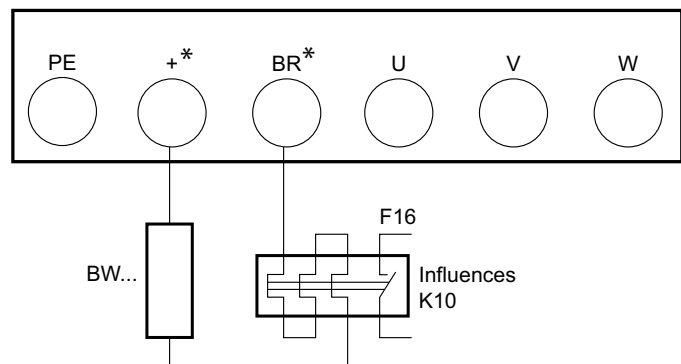

30714595851

* No + and BR connection in size 1

4.4.10 Motor temperature protection TF, TH

Motors with an internal temperature sensor (TF, TH, or equivalent) can be connected directly to the frequency inverter.

If the thermal protection is triggered, the inverter displays the error "F-PTC".

The following types can be selected for motor protection monitoring:

- PTC-th for thermal sensor TF or bimetallic switch TH with trigger threshold 2.5 kΩ

Connection example for the temperature sensors:

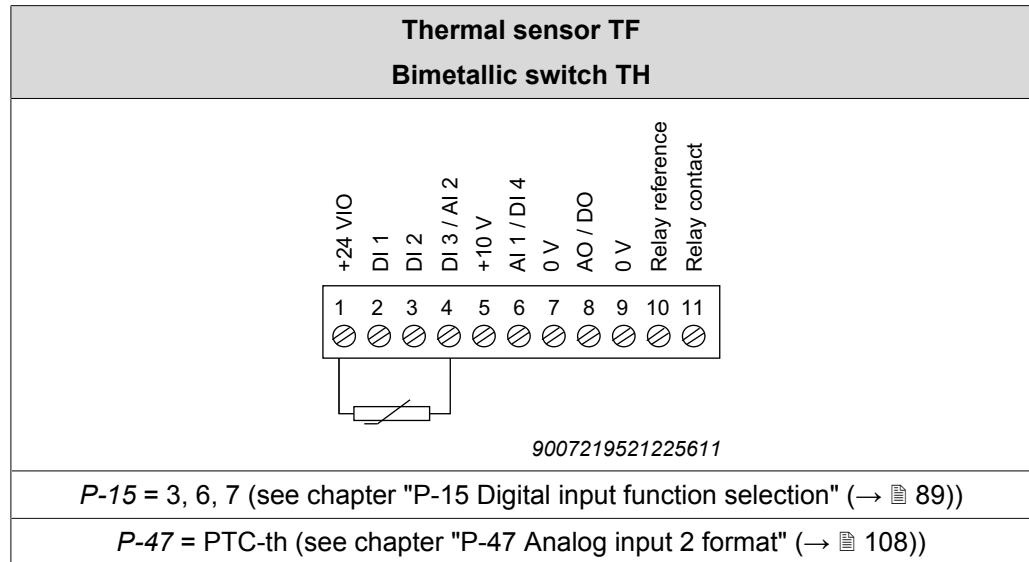

4.4.11 Multi-motor drive/group drive

- The total of the motor currents must not exceed the nominal current of the inverter. The maximum permitted cable length for the group is limited to the values of single connection. See chapter Technical data.
- The motor group is limited to 5 motors and must not differ by more than 3 sizes.
- Multi-motor drive is only possible with AC asynchronous motors, not with synchronous motors.
- SEW-EURODRIVE recommends to use an output choke "HD LT xxx", additionally unshielded cables, and a maximum permitted output frequency of 4 kHz for groups of more than 3 motors.

Maximum motor cable length

The permitted total length of all motor supply leads connected in parallel (I_{tot}) must not exceed the maximum permitted motor cable length of the individual inverter (I_{max}).

$$I_{tot} \leq \frac{I_{max}}{n}$$

3172400139

I_{tot} = Total length of the motor supply leads connected in parallel

I_{max} = Maximum motor lead length (see chapter "Technical data" (→  113))

n = Number of motors connected in parallel

Fusing

No additional fusing is required if the cross section of the motor supply cable corresponds to that of the supply system cable. If the cross section of the motor supply cable is smaller than the cross section of the supply system cable, you must secure the motor supply cable against short circuit for the corresponding cross section. Motor circuit breakers are suitable for this.

Comply with the regulations issued by specific countries and for specific machines regarding fusing and the selection of supply system and motor cables.

4.4.12 Connecting AC brakemotors

For detailed information about the SEW-EURODRIVE brake system, refer to the "AC Motors" catalog, which you can order from SEW-EURODRIVE.

SEW-EURODRIVE brake systems are disk brakes with a DC coil that release electrically and brake using spring force. A brake rectifier supplies the brake with DC voltage.

INFORMATION



The brake rectifier must have a separate supply system cable for inverter operation. Supply via the motor voltage is not permitted.

4.4.13 Information Regarding UL



INFORMATION

Due to UL requirements, the following chapter is always printed in English independent of the language of the documentation.

Ambient Temperature

The units in IP20 are suitable for an ambient temperature of 40 °C, max. 50 °C¹⁾.

The units in IP66 are suitable for an ambient temperature of 40 °C, max 45 °C.

1) 200 – 240 V, 2.2 kW, max. 45 °C

Thermal motor protection

Thermal motor overload protection shall be provided by one of the following means:

- NEC compliant installation of a motor temperature sensor, see also section "Motor temperature protection (TF/TH)" in the chapter "Electrical Installation" of the operating instructions.
- Using internal thermal motor overload protection according to NEC (National Electrical Code, US). Thermal motor overload protection can be activated via parameter *P-41*.
- Implementing external measures to ensure thermal motor overload protection according to NEC (National Electrical Code).

Parameter

The following parameter must be set to enable the internal thermal motor protection according to NEC:

- *P-41* Thermal motor protection according to NEC
 - 0: disabled
 - 1: enabled

Functional principle

The motor current is accumulated in an internal memory over the course of time. The inverter goes to fault state as soon as the thermal limit is exceeded (I.t-trP).

Once the output current of the inverter is less than the set rated motor current, the internal memory is decremented depending on the output current.

- When *P-41* is disabled, thermal memory retention is reset upon shutdown or power loss.
- When *P-41* is enabled, thermal memory retention is maintained upon shutdown or power loss.

Branch Circuit Protection

1 × 110 – 115 V devices			
Devices	Fuses or MCB (type B)	Max. supply short circuit current	Max. line voltage
0004	10 A	100 kA rms (AC)	115 V
0008	20 A		
0011	30 A		
1 × 200 – 240 V devices			
Devices	Fuses or MCB (type B)	Max. supply short circuit current	Max. line voltage
0004	6 A	100 kA rms (AC)	240 V
0008	10 A		
0015	17.5 A		
0022	25 A		
0040	40 A		
3 × 200 – 240 V devices			
Devices	Fuses or MCB (type B)	Max. supply short circuit current	Max. line voltage
0015	15 A	100 kA rms (AC)	240 V
0022	17.5 A		
0040	30 A		
0055	35 A		
0075	45 A		
0110	70 A		
0150	80 A		
0185	100 A		
3 × 380 – 480 V devices			
Devices	Fuses or MCB (type B)	Max. supply short circuit current	Max. line voltage
0008	6 A	100 kA rms (AC)	240 V
0015	10 A		
0022	10 A		
0040	15 A		
0055	25 A		
0075	30 A		
0110	35 A		
0150	45 A		
0185	60 A		
0220	70 A		
0300	80 A		
0370	100 A		

4.4.14 Electromagnetic compatibility (EMC)

Inverters with EMC filters are designed for use in machines and drive systems. They meet the EMC product standard EN 61800-3 for drives with variable speed. Observe the specifications of Directive 2014/30/EU for EMC-compliant installation of the drive system.

Interference immunity

With regard to interference immunity, the inverter with EMC filter satisfies the limit values of standard EN 61800-3 and can therefore be used both in industrial and household applications (light industry).

Interference emission

With regard to interference emission, the inverter meets the EMC limit values of the standard EN 61800-3:2004. The inverters are suitable for industrial as well as household applications (light industry).

Install the inverters as specified in chapter Installation to ensure best possible electromagnetic compatibility. Ensure proper ground connections for the inverters. Use shielded motor cables to comply with the specifications on interference emission.

The conditions for use in drive applications are defined in the following tables.

Inverter type with filter	Cat. C1 (class B)	Cat. C2 (class A)	Cat. C3
230 V, 1-phase LTE-B xxxx 2B1-x-xx	No additional filtering required. Use a shielded motor cable.		
230 V/400 V, 3-phase LTE-B xxxx 2A3-x-xx LTE-B xxxx 5A3-x-xx	Use an external filter of the type NF LT 5B3 0xx. Use a shielded motor cable.	No additional filtering required.	

Use an external filter and a shielded motor cable to comply with the specifications on frequency inverters without internal filter.

General information about connecting the motor shield

For all applications with a expectedly higher EMC load, using shielded cables is recommended. The shield must be connected as follows:

Connect the shield by the shortest possible route and make sure it is earthed over a wide area at both ends. This also applies to cables with several shielded core strands.

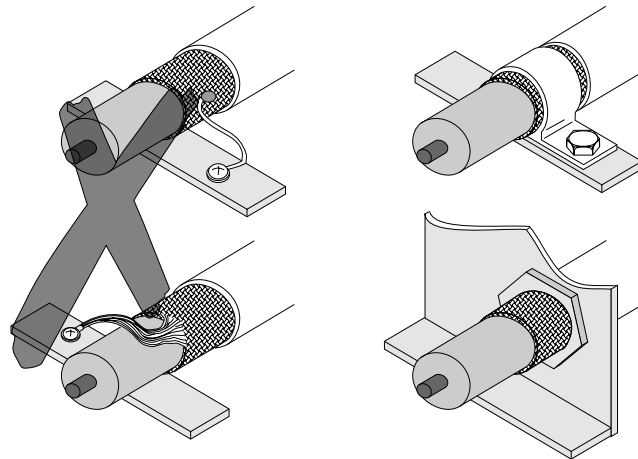

9007200661451659

4 Installation

Electrical installation

Recommendation for motor shield connection at frequency inverters with IP20

Size 2 and 3

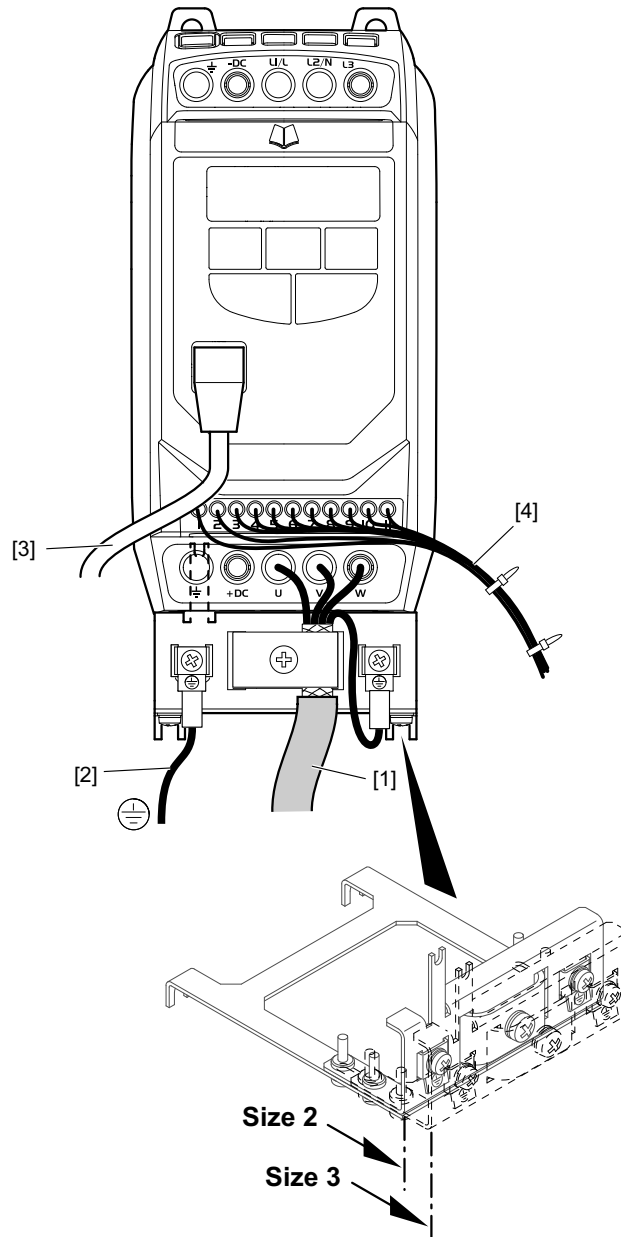

17304181003

- | | | | |
|-----|--------------------------|-----|--------------------------|
| [1] | Motor cable | [3] | Communication cable RJ45 |
| [2] | Additional PE connection | [4] | Control cables |

The shield plate can be used optionally for size 2 and 3 of the IP20 design. Proceed as follows to adjust:

1. Loosen the 4 screws on the slotted holes
2. Move the plate up to the stop according to the required size.
3. Tighten the screws again.

Make sure that the plate is correctly attached to the PE connection.

Recommendation for motor shield connection at frequency inverters with IP66

The cable entry on the device is made of metal. It is therefore possible to fasten a corresponding metal screw fitting directly.

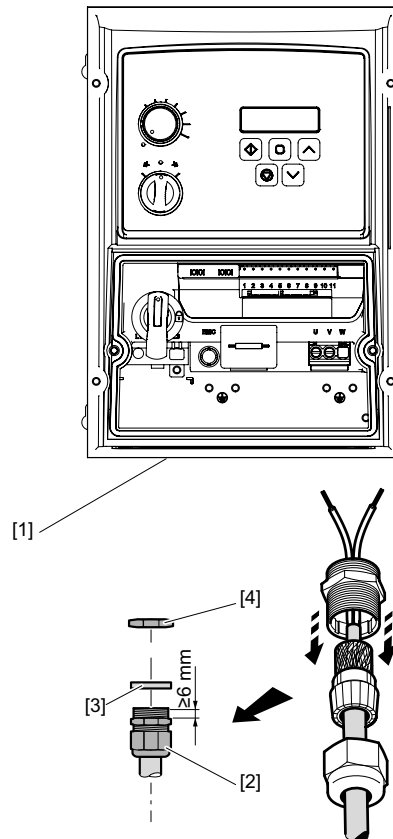

18014415813668363

- [1] Cable entry
- [2] EMC screw fitting
- [3] Seals for cable gland (enclosed with the device)
- [4] EMC counter nut

The use of metal screw fittings is recommended to connect the motor shield to the device. The thread must be at least 8 mm long.

4.4.15 Overview of signal terminals

⚠ CAUTION



Applying voltages of more than 30 V to the signal terminals can damage the controller.

Possible damage to property.

- The voltage applied to the signal terminals must not exceed 30 V.

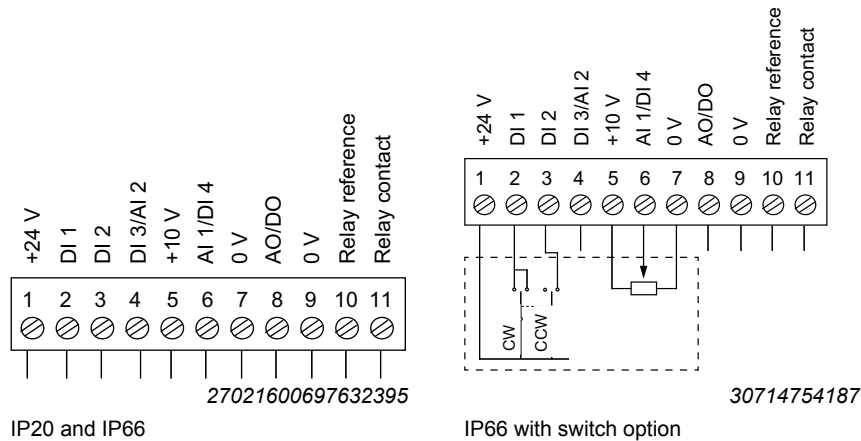

INFORMATION



In the device variant IP66 with switch and potentiometer, the assignment to the corresponding terminal functions is connected internally. In the case of the external use of terminals 2, 3, and 6, the internally fitted switches and potentiometers can be deactivated. For the relevant procedure, refer to chapter "P-00 Configuration parameters for IP66/NEMA-4X devices with switch option" (→ 112).

The signal terminal block is equipped with the following signal terminals:

INFORMATION



If the inputs of the inverter are supplied by an external 24 V voltage supply or PLC, the GND reference potential must be connected to the terminals 7 and 9. The control electronics of the inverter work in isolated fashion.

- Do not connect any inductive loads to the relay contact.

Terminal no.	Signal	Connection	Description
1	+24 V	Output +24 V: Reference voltage	Reference voltage for the control of the digital inputs (100 mA max.)
2	DI 1	Digital input 1	Compatible with PLC requirement if 0 V is connected to terminal 7 or 9
3	DI 2	Digital input 2	
4	DI 3/AI 2	Digital input 3 Analog input 2 (12 bit)	Digital: 0/24 V Analog: 0 – 10 V, 0 – 20 mA, 4 – 20 mA, 20 – 4 mA, PTC-th
5	+10 V	Output +10 V: Reference voltage	10 V reference voltage for analog input (Pot. supply +, max. 10 mA, 1 kΩ min.)
6	AI 1/DI 4	Analog input 1 (12 bit) Digital input 4	Analog: 0 – 10 V, 0 – 20 mA, 4 – 20 mA, 20 – 4 mA Digital: 0/24 V
7	0 V	0 V: Reference potential	0 V: Reference potential for analog input (potential supply -)
8	AO/DO	Analog output (10 bit) Digital output	Analog: 0 – 10 V, max. 20 mA Digital: 0/24 V, max. 20 mA
9	0 V	0 V: Reference potential	0 V: Reference potential for analog output
10	Relay reference	Input relay switching voltage	NO contact (AC 250 V/DC 30 V, max. 5 A)
11	Relay contact	Relay contact	

The following switching thresholds apply to all digital inputs and multi-functional inputs (binary operated):

Logical "1" input voltage range 8 – 30 V

Logical "0" input voltage range 0 – 2 V

Response time of the digital inputs: < 8 ms

Resolution and response time of the analog inputs: 12 bit, < 16 ms

Resolution of the update time of the analog outputs: 10 bit, 64 ms

4.4.16 Communication socket RJ45

NOTICE

Voltage at socket not suitable for PCs.

Damage to PC when connected directly to RJ45 communication socket.

- Use the engineering adapters as described in the chapter "Software LT Shell" (→ 43).

Socket at device

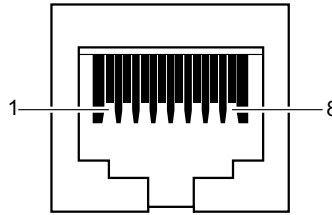

9007212770640779

- [1] SBus-/CAN bus-
- [2] SBus+/CAN bus+
- [3] 0 V
- [4] RS485- (engineering)
- [5] RS485+ (engineering)
- [6] +24 V (output voltage/backup voltage)
- [7] RS485- (Modbus RTU)
- [8] RS485+ (Modbus RTU)

4.4.17 DC link connection, U_z connection

The DC link connection is not possible for LTE-B+ inverters in size 1 – 3, but it is possible to supply the inverter directly with a DC voltage.

For inverters of size 4 and 5, the DC link is extended out to terminals.

Contact SEW-EURODRIVE in such a case.

4.4.18 Wiring diagram



⚠ WARNING

Danger of electric shock. Incorrect wiring can lead to dangerously high voltages.

Severe or fatal injuries.

- Adhere to the following points.

In the following applications, always deactivate the brake in the AC and DC circuits:

- Applications that require a quick brake reaction time.

Please note the following:

- Connect the brake rectifier using a separate supply system cable.
- Supply via the motor voltage is not permitted.

INFORMATION



In the case of a new device, the terminal slots + (DC+) and BR have covers installed that must be broken out, if required.

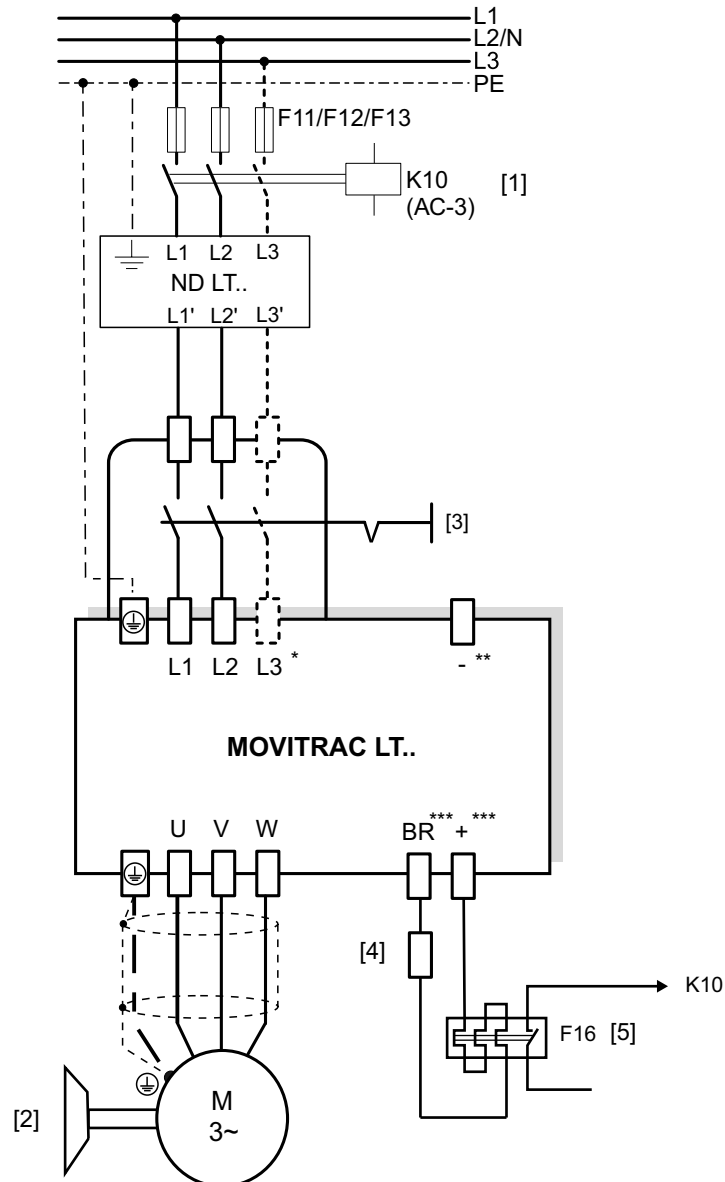

9007219523508363

- [1] Line contactor between supply system and inverter.
- [2] Brake
- [3] Main switch (only in device design IP66/NEMA-4X housing with switch (MC LTE-B..-40))
- [4] Connection of braking resistor BW../BW..T
- [5] Bimetallic relay for the protection of the braking resistor
- * Not in 1-phase 230 V
- ** No -U_z connection in sizes 1 – 3
- *** No BR- and +U_z connection in size 1

4.4.19 Brake control

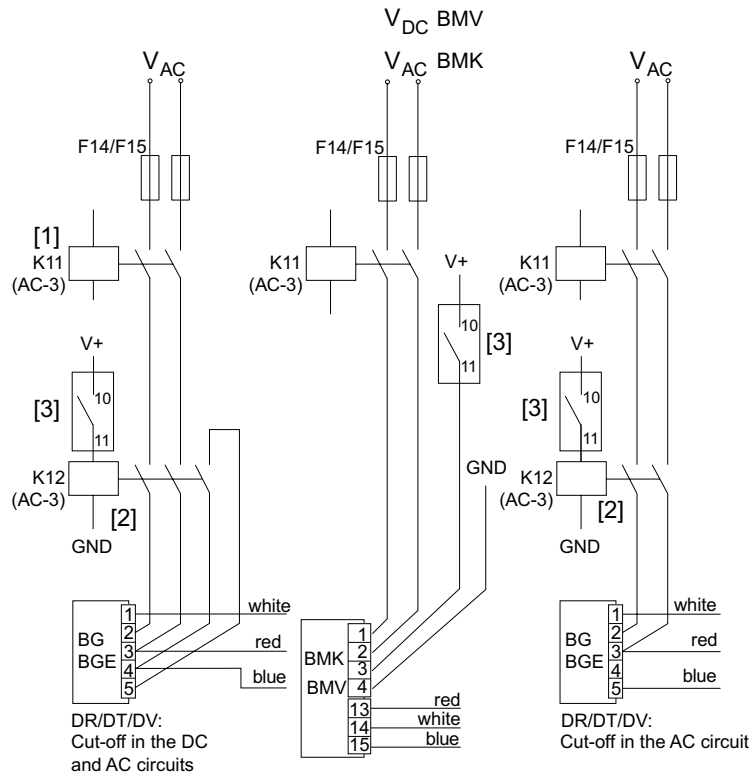

20268785675

- [1] Power supply of the brake rectifier, switched simultaneously via K10.
- [2] Control contactor/control relay, is powered by the internal relay contact [3] of the inverter and supplies the brake rectifier.
- [3] Isolated relay contact of the inverter.
- V+ External voltage supply AC 250 V / DC 30 V at max. 5 A.
- V_{DC} (BMV) DC voltage supply BMV.
- V_{AC} (BMK) AC voltage supply BMK.

5 Startup

5.1 User interface

5.1.1 Keypads

The inverters are equipped with a standard keypad.

Standard keypad

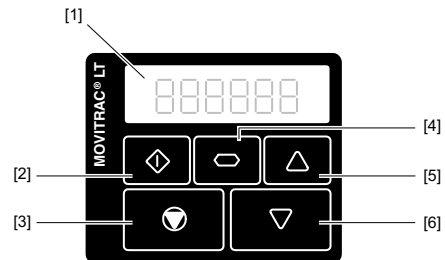

9007202188405387

[1] 6-digit 7-segment display

[2] Start button

[3] Stop/Reset button





[4] Navigate button

[5] Up button

[6] Down button

Operation

Both keypads have 5 keys with the following functions:

- | | | |
|---|--------------|---|
| Key  | Start [2] | <ul style="list-style-type: none"> • Enable drive • Change direction of rotation |
| Key  | Stop [3] | <ul style="list-style-type: none"> • Stop drive • Error acknowledgment |
| Key  | Navigate [4] | <ul style="list-style-type: none"> • Switch menu • Save parameter values • Display real time information |
| Key  | Up [5] | <ul style="list-style-type: none"> • Increase the speed • Increase parameter values |
| Key  | Down [6] | <ul style="list-style-type: none"> • Decrease speed • Decrease parameter values |





The parameter edit menu can only be accessed by pressing the <Navigate> key [4].

- To switch between the menu for changing parameters and real-time display (operating speed/operating current): keep the key pressed for longer than 1 second.
- Switch between operating speed and operating current of the running inverter: press the key briefly (< 1 second).

The operating speed is only displayed if a nominal motor speed has been entered in *P-10*. Otherwise, the electrical rotating field speed is displayed.

5.1.2 Resetting parameters to default settings

To reset the parameters to the factory setting, proceed as follows:

1. The inverter must not be enabled and the display must show "Stop".
2. Press the 3 keys , , and  simultaneously for at least 2 s.
"P-deF" appears on the display.
3. Press the  key to acknowledge the "P-deF" message.

5.1.3 Software LT Shell

The LT Shell software enables an easy and quick startup of the inverters. It is available for download on the SEW-EURODRIVE website. After the installation, perform software updates on a regular basis.

In combination with the engineering package (cable set C) and the USB11A interface adapter, the inverter can be connected to the software.

Maximum 63 inverters can be connected to an LT Shell in a network.

The software can be used to carry out the following tasks:

- Observe, upload and download parameters.
- Save parameter settings.
- Firmware update (manual and automatic).
- Export inverter parameters to Microsoft® Word.
- Monitor the state of the inputs and outputs and the motor.
- Control inverter/manual mode.
- Scope.

Connection to LT Shell

The connection can be performed via an RS485 interface (USB11A + PC Engineering package) or via Bluetooth® (parameter module).

Connection to LT Shell via RS485

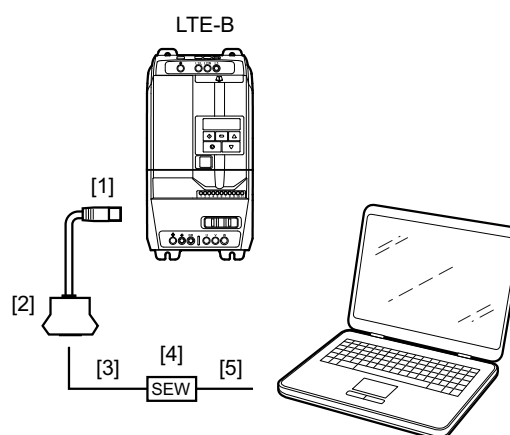

9007212384652427

- | | | | |
|-----|---------------------------------|-----|---------------|
| [1] | RJ45 to RJ45 cable | [4] | USB11A |
| [2] | RJ adapter (2 × RJ45, 1 × RJ10) | [5] | Cable USB A-B |
| [3] | RJ10 to RJ10 cable | | |

Connection to LT Shell via Bluetooth® parameter module

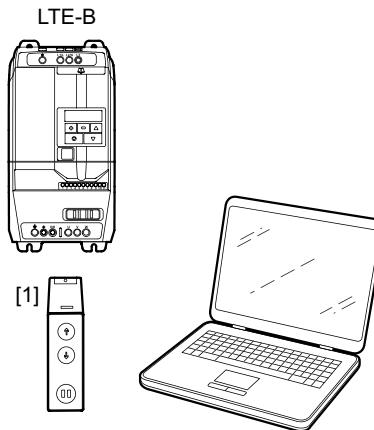

21436331019

[1] Parameter module

5.1.4 MOVITOOLS® MotionStudio engineering software

The software can be connected to the inverter as follows:

- Via an SBus-connection between PC and inverter. A CAN dongle is required. A prefabricated cable is not available and must be manufactured according to the RJ45 assignment and the inverter interface.
- Via a connection of the PC with a gateway or a MOVI-PLC®. The connection between PC and gateway/MOVI-PLC® is possible via USB11A, USB or Ethernet.

The following functions are available in MOVITOOLS® MotionStudio:

- Observe, upload and download parameter
- Save parameter settings
- Monitor the state of the inputs/outputs and the motor.

Connection to MOVITOOLS® MotionStudio

The connection can be set up indirectly via an SEW-EURODRIVE gateway or an SEW-EURODRIVE controller.

Connection to MOVITOOLS® MotionStudio via gateway

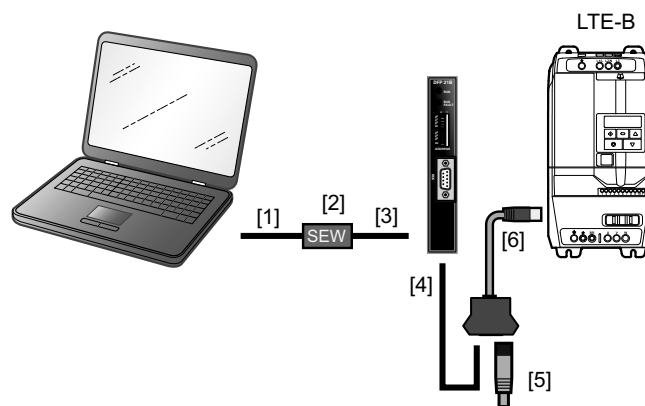

21436360459

- | | |
|------------------------|-----------------------------------|
| [1] Cable USB A-B | [4] RJ45 cable with open end |
| [2] USB11A | [5] Terminating connector (120 Ω) |
| [3] RJ10 to RJ10 cable | [6] Cable splitter |

Connection to MOVITOOLS® MotionStudio via controller

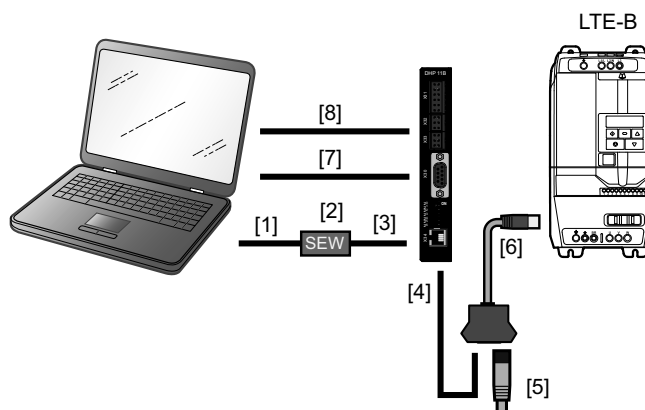

21436415243

- | | |
|------------------------------|-----------------------------------|
| [1] Cable USB A-B | [5] Terminating connector (120 Ω) |
| [2] USB11A | [6] Cable splitter |
| [3] RJ10 to RJ10 cable | [7] Cable USB A-B |
| [4] RJ45 cable with open end | [8] RJ45 Ethernet cable |

Connection to MOVITOOLS® MotionStudio via SBus with USM21A

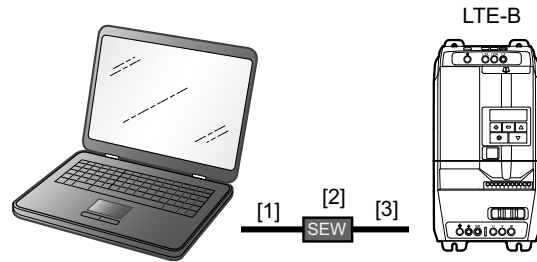

30574989707

- | |
|------------------------|
| [1] Cable USB A-B |
| [2] USM21A |
| [3] RJ10 to RJ45 cable |

5.2 "Auto tune" automatic measuring procedure

You can also start the "Auto tune" automatic measuring procedure manually with the parameter *P-52* after entering the motor data. This procedure can take up to 2 minutes, depending on the control mode.

Do not interrupt the measuring procedure.

Do not start the measuring procedure until all the motor data was entered correctly.

The inverter must not be enabled for the measuring procedure. "Stop" has to be displayed.

5.3 Startup for motors



▲ WARNING

When parameter *P-52* is set to "1" (auto tune) the motor may start up automatically. Severe or fatal injuries.

- Make sure that no persons are within the reach of moving parts of the system.



INFORMATION

The ramp times in parameters *P-03* and *P-04* refer to 50 Hz.

5.3.1 Startup with asynchronous motors with V/f control

1. Connect the motor to the inverter. During the connection, adhere to the nominal motor voltage.
2. Enter the motor data of the motor nameplate:
 - *P-07* = nominal voltage of the motor
 - *P-08* = rated current of the motor
 - *P-09* = rated frequency of the motor
 - *P-10* = rated speed of the motor
 - Value = 0: Slip compensation deactivated
 - Value ≠ 0: Slip compensation activated
 - *P-14* = 101 (extended parameter access)
 - *P-51* = 1 (V/f open-loop speed control)
3. Set the maximum and minimum speed with *P-01* and *P-02*.
4. Set the acceleration and deceleration ramps using *P-03* and *P-04*.

5.3.2 Startup with asynchronous motors with LVFC speed control

1. Connect the motor to the inverter. During the connection, adhere to the nominal motor voltage.
2. Enter the motor data indicated on the motor nameplate:
 - *P-07* = rated voltage of the motor
 - *P-08* = rated current of the motor
 - *P-09* = rated frequency of the motor
 - *P-10* = rated speed of the motor
 - *P-14* = 101 (extended parameter access)
 - *P-51* = 0 (LVFC speed control)
3. Set the maximum and minimum speed using *P-01* and *P-02*.
4. Set the acceleration and deceleration ramps using *P-03* and *P-04*.
5. Start the "Auto tune" automatic motor measurement procedure as described in chapter "Auto tune" (→ 47).
6. If the control performance is not adequate, you can optimize the control behavior using the parameters *P-53 Level 1 + 2* (P-share, I-share).

5.3.3 Startup with LSPM motors from SEW-EURODRIVE

DR..J type motors are motors with LSPM technology (Line Start Permanent Magnet motors).

1. Connect the motor to the inverter. During the connection, adhere to the nominal motor voltage.
2. Enter the motor data indicated on the motor nameplate:
 - *P-07* = internal voltage (EMF) at nominal motor speed
 - *P-08* = rated current of the motor
 - *P-09* = rated frequency of the motor
 - *P-10* = rated speed of the motor
 - *P-14* = 101 (extended parameter access)
 - *P-51* = 5 (LSPM speed control)
3. Set the maximum speed *P-01* and minimum speed *P-02* to 300 min⁻¹.
4. Set the acceleration and deceleration ramps using *P-03* and *P-04*.
5. Start the "Auto tune" automatic motor measurement procedure as described in chapter "Auto tune" (→ 47).
6. Adjust the boost with *P-11*.
7. If the control performance is not adequate, you can optimize the control behavior using the parameters *P-53 Level 1 + 2* (P-share, I-share).

5.3.4 Startup of synchronous motors without encoder feedback (PMVC speed control)



INFORMATION

The operation of synchronous motors without encoder must be checked in a test application. Stable operation in this operating mode cannot be ensured for all application cases.

1. Connect the motor to the inverter. During the connection, adhere to the nominal motor voltage.
2. Enter the motor data indicated on the motor nameplate:
 - *P-07* = internal voltage (EMF) at nominal motor speed
 - *P-08* = rated current of the motor
 - *P-09* = rated frequency of the motor
 - *P-10* = rated speed of the motor
 - *P-14* = 101 (extended parameter access)
 - *P-51* = 2 (PMVC speed control)
3. Set the maximum speed with *P-01* to the maximum motor measurement speed and the minimum speed with *P-02* to a minimum of 10% of the motor measurement speed.
4. Set the acceleration and deceleration ramps using *P-03* and *P-04*.
5. Start the "Auto tune" automatic motor measurement procedure as described in chapter "Auto tune" (→ 47).
6. Adjust the boost with *P-11*.
7. If the control performance is not adequate, you can optimize the control behavior using the parameters *P-53 Level 1 + 2* (P-share, I-share).

5.3.5 Startup with brushless DC motors (BLDC speed control)

1. Connect the motor to the inverter. During the connection, adhere to the nominal motor voltage.
2. Enter the motor data indicated on the motor nameplate:
 - *P-07* = internal voltage (EMF) at nominal motor speed
 - *P-08* = rated current of the motor
 - *P-09* = rated frequency of the motor
 - *P-10* = rated speed of the motor
 - *P-14* = 101 (extended parameter access)
 - *P-51* = 3 (BLDC speed control)
3. Set the maximum and minimum speed using *P-01* and *P-02*.
4. Set the acceleration and deceleration ramps using *P-03* and *P-04*.
5. Start the "Auto tune" automatic motor measurement procedure as described in chapter "Auto tune" (→ 47).
6. Adjust the boost with *P-11*.
7. If the control performance is not adequate, you can optimize the control behavior using the parameters *P-53 Level 1 + 2* (P-share, I-share).

5.3.6 Startup with synchronous reluctance motors (SYN-R speed control)

1. Connect the motor to the inverter. During the connection, adhere to the nominal motor voltage.
2. Enter the motor data indicated on the motor nameplate:
 - *P-07* = rated voltage of the motor
 - *P-08* = rated current of the motor
 - *P-09* = rated frequency of the motor
 - *P-10* = rated speed of the motor
 - *P-14* = 101 (extended parameter access)
 - *P-51* = 4 (SYN-R speed control)
3. Set the maximum and minimum speed using *P-01* and *P-02*.
4. Set the acceleration and deceleration ramps using *P-03* and *P-04*.
5. Start the "Auto tune" automatic motor measurement procedure as described in chapter "Auto tune" (→ 47).
6. Adjust the boost with *P-11*.
7. If the control performance is not adequate, you can optimize the control behavior using the parameters *P-53 Level 1 + 2* (P-share, I-share).

5.4 Startup of the control signal source



▲ WARNING

Installing sensors or switches at the terminals may cause an enable signal. The motor may start up automatically.

Severe or fatal injuries.

- Make sure that no persons are within the reach of moving parts of the system.
- Install the switches in open state.
- If you install a potentiometer, set it to 0 first.

5.4.1 Terminal mode (factory setting) $P-12 = 0$

For operation in terminal mode (factory setting):

- $P-12$ must be set to "0" (factory setting).
- Change the input terminal configuration according to your demands in $P-15$. For the possible settings, see chapter "P-15 Digital input function selection" (→ 89).
- Connect a switch between terminals 1 and 2 on the user terminal block.
- Connect a potentiometer (1 k – 10 k) between terminals 5, 6 and 7. The center tap is connected to terminal 6.
- Enable the inverter by establishing a connection between terminals 1 and 2.
- Set the speed using the potentiometer.

5.4.2 Keypad mode (*P-12* = 1 or 2)

For operation in keypad mode:

- Set *P-12* to "1" (unidirectional) or "2" (bidirectional).
- Connect a jumper or switch between terminals 1 and 2 on the terminal block to enable the inverter.
- Press the <Start> key. The inverter is enabled with 0.0 Hz.
- To increase the speed, press the <Up> key. To decrease the speed, press the <Down> key.
- To stop the inverter, press the <Stop/reset> key.
- After the <Start> key is pressed, the inverter starts according to the setting in *P-31*. If bidirectional mode is enabled (*P-12* = 2), the direction of rotation is reversed by pressing the <Start> key again.

INFORMATION



You can preset the required target speed by pressing the <Stop/reset> key at standstill. Pressing the <Start> key then moves the drive along the preset ramp until it has reached the required speed.

5.4.3 PI controller mode (*P-12* = 9 or 10)

The implemented PI controller can be used for temperature control, pressure control, or other applications.

General information on use

Connect the sensor for the controlled variable to analog input 1 depending on *P-45 Level 2*. You can scale the sensor value using parameter *P-40 Level 2* in such a way that the value is indicated correctly on the inverter display, e.g. 0 – 10 bar.

You can set the target reference for the PI controller using *P-45 Level 1*.

The following figure shows the configuration options for the PI controller.

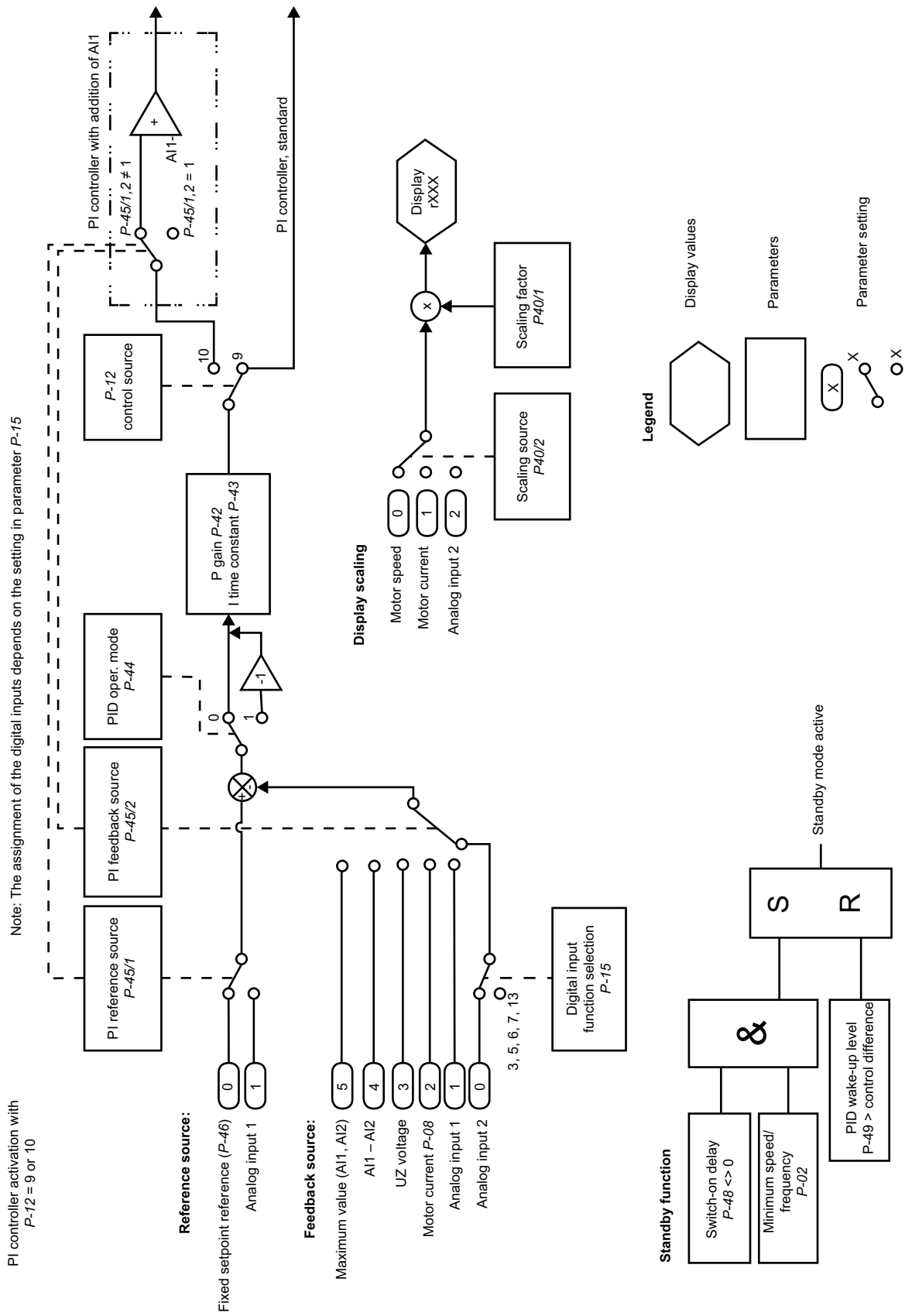

9007219545143179

5 Startup

Startup of the control signal source

5.4.4 Master-slave mode (P-12 = 11)

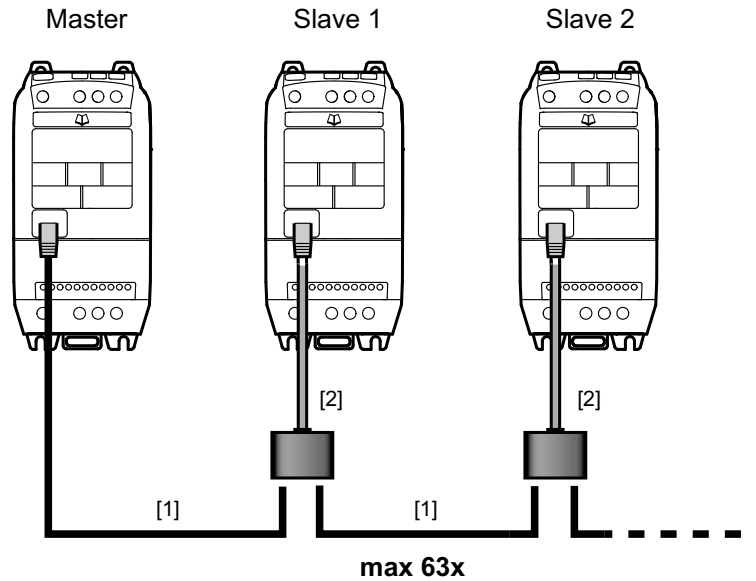

16873961867

- [1] RJ45 to RJ45 cable
- [2] Cable splitter

The inverter has an integrated master-slave function.

The master-slave communication is obtained via a special protocol. In this case, the inverter communicates via the RS485 engineering interface. Up to 63 inverters can be connected with one another in a communication network using RJ45 connectors.

One inverter is configured as master, the remaining inverters as slaves. Each network may have only one master inverter. This master inverter sends its operating state (such as stopped, running) and output frequency every 30 ms. The slave inverters then follow the state of the master frequency inverter.

Configuration of the inverters for speed synchronism

Parameter description	Master settings	Slave settings
P-03 (acceleration ramp)	Customized	≤ master ramps
P-04 (deceleration ramp)		
P-12 (control source)	0,1,2,3,4,5,6,7,8,9,10	11
P-14 (extended parameter menu)	101	101
P-31 Level 1 (inverter address)	1	2 – 63
P-35 (slave scaling)	–	Customized

INFORMATION



Cable set B can be used for setting up the master-slave network. It is not necessary to use a terminating resistor. For information on the cable sets, refer to the catalog.

5.4.5 Fieldbus mode (P-12 = 3, 4, 5, 6, 7 or 8)

See chapter "Fieldbus mode" (→ 65).

29135451/EN – 01/2020

5.5 Fire mode/emergency mode

Set the fire mode/emergency mode as follows:

- Perform a motor startup.
- Set parameter *P-14* to "101" to access further parameters.
- Set parameter *P-15* to "13" to be able to use the fire mode/emergency mode using digital inputs.
- Connect the signal for activating the fire mode/emergency mode to DI 3.
- Set parameter *P-60* to the speed that is used in fire mode/emergency mode. You can specify a positive or a negative speed setpoint.

You can read out *P00-47* to analyze the fire mode/emergency mode.

INFORMATION



When the "fire mode/emergency mode" is activated, the inverter drives the motor with the preset values. In this mode, the inverter ignores all errors, shutdowns, and setpoints and operates the motor until it is destroyed or until the loss of voltage supply. It is also not possible in this mode to perform a reset to the factory setting. Enabling this mode stops operation.

5.6 Operation at 87 Hz characteristic (50 Hz motors)

The V/f ratio remains the same at 87 Hz operation. However, higher power and speeds are generated which causes a higher current flow.

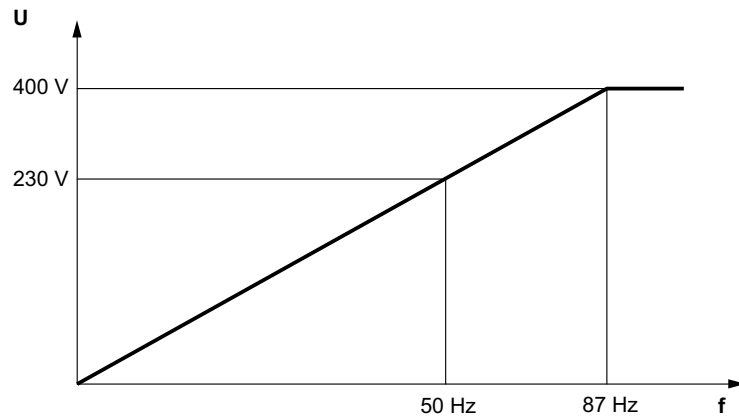

9007206616827403

Set the "87 Hz characteristic" operation as follows:

- Set the parameter $P-07$ to star voltage (data on the motor nameplate).
- Set the parameter $P-08$ to delta current (data on the motor nameplate).
- Set the parameter $P-09$ to "87 Hz".
- Set the parameter $P-10$ to "(Synchronous speed at nominal frequency) \times (87 Hz/50 Hz) - (slip speed at nominal frequency)".

Example for calculating P-10:

DRN80M4: 0.75 kW, 50 Hz

Nominal speed 1440 min^{-1}

$$P-10 = 1500 \text{ min}^{-1} \times (87 \text{ Hz}/50 \text{ Hz}) - (1500 \text{ min}^{-1} - 1440 \text{ min}^{-1}) = 2550 \text{ min}^{-1}$$

INFORMATION



Set $P-01$ *maximum speed* according to your requirements. In 87 Hz operation, the inverter has to provide a current that is $\sqrt{3}$ -times higher. For this purpose, select an inverter with a $\sqrt{3}$ -times higher power rating.

5.7 Fans and pumps

The following functions are available for applications with pumps or fans:

- Voltage boost (*P-11*)
- Adjustment of the V/f characteristic curve (*P-28*, *P-29*)
- Energy-saving function (*P-06*)
- Flying start function (*P-33*)
- DC current holding function (*P-32*)
- Standby mode (*P-48*)
- PI controller; see chapter "PI controller mode (*P-12* = 9 or 10)" (→ 52)
- Fire mode/emergency mode; see chapter "Fire mode/emergency mode" (→ 55)
- Deactivating slip compensation via rated motor speed (*P-10*)
- Skip function (*P-26/P-27*)

5.8 Motor potentiometer

The motor potentiometer function lets the inverter respond to key commands.

This function is available only in the keypad mode *P-12* = 1 or 2.

If the digital inputs are activated that increase or decrease the speed, the speed changes along the preset ramps *P-03* and *P-04*.

To be able to use the motor potentiometer function, select a function in parameter *P-15* that uses the digital inputs for increasing or reducing the speed. See also chapter "P-15 Digital input function selection" (→ 89) under the table Keypad mode.

When using this function, the arrow-up and arrow-down keys can also be used directly on the inverter.

5.9 3-wire control

The function is activated via the digital input function selection *P-15* = 11.

The 3-wire control principle determines the control.

The enabling and direction of rotation signals of the inverter then respond in an edge-controlled way.

- Connect the start key <CW> with NO contact to digital input DI1.
- Connect the start key <CCW> with NO contact to digital input DI3.
- Connect the stop key as NC contact to digital input DI2.

If you connect <CW> and <CCW> at the same time, the drive decelerates along the rapid stop ramp *P-24*.

5.9.1 Control signal source 3-wire control

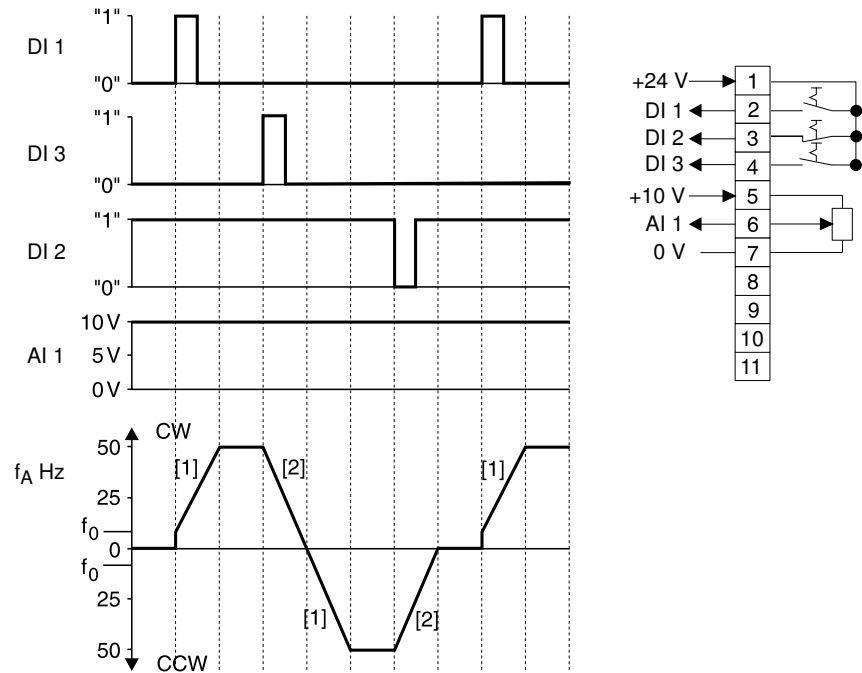

9007218080811659

DI 1	CW/stop	CW	CW rotation
DI 3	CCW/stop	CCW	CCW rotation
DI 2	Enable/stop	[1]	Ramp up (<i>P-03</i>)
AI 1	Setpoint input AI	[2]	Ramp down (<i>P-04</i>)
f_A	Output frequency		
f_0	Start/stop frequency		

6 Operation

6.1 Status of the inverter

6.1.1 Static inverter status

The following table shows the status messages when the inverter is not enabled.

Message	Description
StoP	Power section of inverter disabled. This message is displayed when the motor is at standstill and no error is present. The inverter is ready for normal operation.
P-deF	Parameter factory settings have been loaded. This message appears when the user issues the command for loading the parameter factory settings. To put the inverter into operation again, press the <Reset> key.
Standby	Inverter is in standby mode. This message is displayed when the inverter ran previously at minimum speed (P-02) for the period of time defined in the parameter Standby mode (P-48) and the speed setpoint is lower than/equal to the minimum speed.

6.1.2 Operating state of the inverter

The following table shows the messages of the status for an enabled inverter.

You can toggle between output frequency, output current, output power, and speed by briefly pressing the <Navigate> key on the keypad.

Message	Description
H xxx	Output frequency of the frequency inverter (in Hz) Displayed, when the frequency inverter is enabled.
A xxx	Output current of the frequency inverter (in Ampere) Displayed, when the frequency inverter is enabled.
P xxx	Output power of the motor (in kW) Displayed, when the frequency inverter is enabled.
L xxx	The parameter is locked for changes. Make sure that: <ul style="list-style-type: none"> • The parameter lock in P-38 is not activated. • The inverter is not enabled. • The inverter is supplied with line voltage.
xxxx	Output speed of the frequency inverter (in min ⁻¹) This display appears when the frequency inverter is enabled and a value > 0 has been entered in parameter P-10.
C xxx	The scaled speed (P-40).
Auto-t	An automatic measurement of the motor parameters is being performed. This process can take up to 2 minutes.
. (flashing dots)	The output current of the frequency inverter exceeds the current value entered in P-08. The frequency inverter monitors load and duration of the overload. The frequency inverter triggers error message "I.t-trP" depending on the overload.
. . . (alternately flashing dots)	Phase failure or supply voltage outside of specification
. (blinking dot)	Fire mode/emergency mode activated
dELAY.t	Time-delayed reset; see also error description O-I

6.1.3 Error reset

You can reset an error in the event of an error response (see section Error codes) by pressing the <Stop> key or with a rising edge at digital input 1.

6.2 Troubleshooting

Symptom	Cause and solution
Overload or overcurrent error of the unloaded motor during acceleration	Check the star/delta terminal connection in the motor. The nominal operating voltage of motor and inverter must match. The delta connection always yields the lower voltage of a multi-voltage motor.
Overload or overcurrent – motor does not turn	Check whether the rotor is blocked. Make sure that the mechanical brake is released (if installed).
No enable for the inverter – display remains as "StoP"	<ul style="list-style-type: none"> • Check whether the hardware enable signal is present at digital input 1. • Ensure proper +10 V user output voltage (between terminals 5 and 7). • If faulty, check the wiring of the user terminal strip. • Check <i>P-12</i> for terminal mode/keypad mode. • If keypad mode is selected, press the "Start" key. • The line voltage must correspond with the specified values.
The inverter does not start at extremely cold ambient conditions	The inverter might not start at ambient temperatures below -20 °C. Under such conditions, provide a heat source that keeps the ambient temperature of the drive above -20 °C.
No access to advanced menus	<i>P-14</i> must be set to the advanced access code. The value is "101" unless the user has changed the code in <i>P-37</i> .

6.3 Error history

The parameter *P00-28* archives the last four errors. Each error is displayed in abbreviated form. The most recent error is shown first (when calling *P00-28*). The oldest error will be deleted from the error history.

- **NOTE**

If the latest error in the error history is an undervoltage error, no further undervoltage errors will be entered in the error history. The reason is to prevent the error history from being filled with undervoltage errors, which occur every time the inverter is switched off.

6.4 Error list

Code (inverter display)	Code (MotionStudio in P00-28)	Error code status word if Bit5 = 1	CANopen emergency code	Meaning	Measure
4-20 F	18	0x71	0x1012	Signal loss 4 – 20 mA	<ul style="list-style-type: none"> Check whether the input current falls within the range defined in <i>P-16</i> and <i>P-48</i>. Check the connection cable.
AtF-01	40	0x51	0x1028	The measured stator resistance fluctuates between the phases	The measured stator resistance of the motor is asymmetrical. Check to see, if: <ul style="list-style-type: none"> The motor is connected correctly and without error. The windings have the correct resistance and symmetry.
AtF-02	41	0x51	0x1029	The measured stator resistance is too high	The measured stator resistance of the motor is too high. Check to see, if: <ul style="list-style-type: none"> The motor is connected correctly and without error. the power rating of the motor corresponds with the power rating of the connected inverter.
AtF-03	42	0x51	0x102A	Measured motor inductance is too low	The measured motor inductance is too low. Make sure that the motor is connected correctly and without error.
AtF-04	43	0x51	0x102B	Measured motor inductance is too high	The measured motor inductance is too high. Check to see, if: <ul style="list-style-type: none"> The motor is connected correctly and without error. The power rating of the motor corresponds with the power rating of the connected inverter.
AtF-05	44	0x51	0x102C	Timeout of inductance measurement	The measured motor parameters are not convergent. Check to see, if: <ul style="list-style-type: none"> The motor is connected correctly and without error. The power rating of the motor corresponds with the power rating of the connected inverter.
dAtA-E	19	0x62	0x1013	Internal memory error (DSP)	Consult SEW-EURODRIVE.
dAtA-F	17	0x62	0x1011	Internal memory error (IO)	Consult SEW-EURODRIVE.
DC-trP	–	0x2E	0x100C	Communication failure error	Check the communication connection. Make sure each inverter in the network is assigned a unique address.
E-triP	11	0x1A	0x100B	External error at digital input 3	NC contact was opened. <ul style="list-style-type: none"> Check motor thermistor (if connected).
Err-SC				The keypad lost the communication connection to the inverter	Press the STOP key to reset. Check the address of the frequency inverter.
F-Ptc	21	0x1F	0x1015	Motor protection triggered	The motor protection sensor (TF, TH) is connected to the analog input 2 (terminal 4).
FAN-F	22	0x32	0x1016	Internal fan error	Consult SEW-EURODRIVE.
FAULTY				The communication between the controller and the power section is interrupted	Consult SEW-EURODRIVE.
FLt-dc	13	0x07	0x320D	DC link ripple too high	Check the current supply.

Code (inverter display)	Code (MotionStudio in P00-28)	Error code status word if Bit5 = 1	CANopen emergency code	Meaning	Measure
I.t-trp	04	0x08	0x1004	Overload of inverter/motor (I2t error)	<p>Make sure that:</p> <ul style="list-style-type: none"> The motor nameplate parameters are correctly inserted in <i>P-07</i>, <i>P-08</i>, and <i>P-09</i>. Auto Tune has been performed correctly. <p>Check to see, if:</p> <ul style="list-style-type: none"> The decimals flash (inverter overloaded), and then increase the acceleration ramp (<i>P-03</i>) or decrease the motor load. The length of the cable meets the requirements. The load can move freely and there are no blockages or other mechanical faults (mechanically check the load). The thermal motor protection to UL508C is activated in <i>P-41</i>. <p>See also Error reset delay in the case of an O-I and hO-I error.</p>
O-I	03	0x01	0x2303	Short-term overcurrent at the inverter output. High motor overload	<p>Error during stop procedure: Check for premature brake application.</p> <p>Error when enabling the drive: Check to see, if:</p> <ul style="list-style-type: none"> The motor nameplate parameters are correctly inserted in <i>P-07</i>, <i>P-08</i>, and <i>P-09</i>. Auto Tune has been performed correctly. The load can move freely and there are no blockages or other mechanical faults (mechanically check the load). A short circuit between the phases or a ground error of a phase occurred at the motor and motor connection cable. The brake is connected correctly, controlled correctly, and correctly releases when the motor has a holding brake. <p>Error during operation: Check:</p> <ul style="list-style-type: none"> For sudden overload or malfunction. The cable connection between inverter and motor. The acceleration/deceleration time is too short and requires too much power. If you cannot increase <i>P-03</i> or <i>P-04</i>, use a larger inverter. <p>Measures: Reduce the setting of the voltage enhancement in <i>P-11</i>. Set a longer run-up time in <i>P-03</i>. Disconnect the motor from the inverter. Enable the inverter again. If this error occurs again, check the entire system and completely replace the inverter.</p> <p>Error reset delay If the error occurs again immediately after the reset of O-I or hO-I error messages, the following delay times apply for the repeat reset:</p> <ul style="list-style-type: none"> First reset after 4 seconds Second reset after 8 seconds Third reset after 16 seconds Fourth reset after 32 seconds Further resets after 64 seconds
hO-I	15	0x01	0x230F	Hardware overcurrent error at the inverter output (IGBT self-protection in case of overload)	<p>Error during operation: Check:</p> <ul style="list-style-type: none"> For sudden overload or malfunction. The cable connection between inverter and motor. The acceleration/deceleration time is too short and requires too much power. If you cannot increase <i>P-03</i> or <i>P-04</i>, use a larger inverter. <p>Measures: Reduce the setting of the voltage enhancement in <i>P-11</i>. Set a longer run-up time in <i>P-03</i>. Disconnect the motor from the inverter. Enable the inverter again. If this error occurs again, check the entire system and completely replace the inverter.</p> <p>Error reset delay If the error occurs again immediately after the reset of O-I or hO-I error messages, the following delay times apply for the repeat reset:</p> <ul style="list-style-type: none"> First reset after 4 seconds Second reset after 8 seconds Third reset after 16 seconds Fourth reset after 32 seconds Further resets after 64 seconds
O-hEAt	23	0x7C	0x4117	Ambient temperature too high	Check if the ambient conditions are within the range specified for the inverter.
O-t	8	0x0B	0x4208	Heat sink overtemperature	<p>The heat sink temperature can be displayed via <i>P00-09</i>. A historical protocol is saved in parameter <i>P00-16</i> at 30 s intervals prior to a switch off with error. This error message is displayed at a heat sink temperature of ≥ 90 °C.</p> <p>Check:</p> <ul style="list-style-type: none"> The ambient temperature of the inverter. The inverter cooling and housing dimensions. The function of the internal cooling fan of the inverter. <p>Reduce the setting of the effective clock frequency in parameter <i>P-17</i>, or the load at the motor/inverter.</p>

Code (inverter display)	Code (MotionStudio in P00-28)	Error code status word if Bit5 = 1	CANopen emergency code	Meaning	Measure
O-Volt	06	0x07	0x07	DC link over-voltage	The error occurs if a high flywheel load or overhauling load is connected, and the excess regenerative energy is transferred back to the inverter. If the error occurs while stopping or during deceleration, increase the deceleration ramp time <i>P-04</i> or connect a suitable braking resistor to the inverter. Reduce the proportional gain in <i>P-53/1</i> in vector mode. Additionally check if the supply voltage is within the specified range. Information: The value of the DC link voltage (U_2) can be displayed on <i>P00-08</i> . A historical protocol is saved in parameter <i>P00-15</i> at 256 ms intervals prior to a switch off with error.
OI-b	01	0x04	0x2301	Brake channel overcurrent, braking resistor overload	Make sure that the connected braking resistor does not fall below the minimum value approved for the inverter (see technical data). Check the braking resistor and the wiring for possible short circuits. See also Error reset delay in the case of an O-I and hO-I error.
OL-br	02	0x04	0x1002	Braking resistor overload	The software detected an overload at the braking resistor and switches off to protect the resistor. Make sure that the braking resistor is operated within the planned parameters before performing any changes to the parameters or the system. To reduce the load at the resistor, increase the deceleration time, reduce the loads mass moment of inertia, or connect additional braking resistors in parallel. Note the minimum resistor values for the used inverter.
Out-F	26	0x52	0x101A	Inverter output stage error	Check the EMC-compliant cabling of any external control cables. Use shielded cables. As a test, apply use the internal 24 V supply directly to the digital inputs, to rule out errors in the signal cable. As a test, disconnect the temperature sensor to rule out errors in the sensor cable. As a test, disconnect the motor cable from the inverter to rule out errors originating in the inverter. Consult SEW-EURODRIVE.
P-LOSS	14	0x06	0x310E	Input phase failure	An input phase was disconnected or interrupted. Check the supply voltage.
P-dEF	10	0x09	0x100A	Factory settings are restored	
PS-trP	05	0xC8	0x1005	Output stage error (IGBT self-protection in case of overload)	See error O-I .
SC-F01	50	0x2B	0x1032	Modbus communication error	Check the communication settings.
SC-F02	51	0x2F	0x1033	SBus/CANopen communication error	Check: • The communication connection between inverter and external devices. • The clearly assigned address per inverter in the network.
SC-FLt	–	–	–	Internal inverter error	Consult SEW-EURODRIVE.
SC-trP	–	0x2E	0x100C	Communication failure error	Check the communication connection. Make sure each inverter in the network is assigned a unique address.
SC-OBS	12	0x2E	0x100C	Loss of communication between the devices	Check the address of the inverter. Check the communication connection of the inverters.
StoP				The inverter is not enabled	Activate the enable.
th-Flt	16	0x1F	0x1010	Faulty thermistor at heat sink	Consult SEW-EURODRIVE.

29135451/EN – 01/2020

6

Operation

Error list

Code (inverter display)	Code (MotionStudio in P00-28)	Error code status word if Bit5 = 1	CANopen emergency code	Meaning	Measure
type-f				Parameter module and inverter are not compatible	The used parameter module is not of type LT BP C.
U-t	09	0x75	0x4209	Undertemperature	Occurs at an ambient temperature below -20 °C. Increase the temperature to above -20 °C to start the inverter.
U-Volt	07	0xC6	0x3207	DC link under-voltage	Occurs routinely when switching off the inverter. Check the line voltage if this occurs while the inverter is running.

7 Fieldbus mode

7.1 General information

7.1.1 Structure and settings of process data words

The process data assignment is set as standard.

The structure of process data words is identical for SBus/Modbus RTU/CANopen, as well as with inserted communication card.

	High byte	Low byte
Bit	15 – 8	7 – 0

Process output words

Description		Bit		Settings
PO1	Control word	0	Output stage inhibit (the motor coasts to a stop), for brakemotors the brake is applied immediately	0: Start 1: Stop
		1	Rapid stop along the second deceleration ramp/rapid stop ramp (<i>P-24</i>)	0: Rapid stop 1: Start
		2	Stop along process ramp <i>P-03</i> / <i>P-04</i> or <i>PO3</i>	0: Stop 1: Start
		3 – 5	Reserved	0
		6	Error reset	Edge 0 set to 1 = fault reset
		7 – 15	Reserved	0
PO2	Setpoint speed	CW rotation: 0 – 16384 dec $\hat{=}$ 0 – 100% of <i>P-01</i> Counterclockwise rotation (formation of the pair's complement): 49152 dec – 65535 dec $\hat{=}$ -100% – 0 of <i>P-01</i>		
PO3	Ramp time if <i>P-12</i> = 4, 6, 8	1 digit = 1 ms (100 ms – 65535 ms)		
	if <i>P-12</i> = 3, 5, 7	No function Ramp specification via <i>P-03</i> , <i>P-04</i>		

Process input words

Description		Bit		Settings	Byte
PI1	Status word	0	Output stage enable	0: Disabled 1: Enabled	Low byte
		1	Inverter ready	0: Not ready 1: Ready	
		2	PO data enabled	1 if <i>P-12</i> = 3 or 4	
		3 – 4	Reserved		
		5	Error/warning	0: No error 1: Error	
		6 – 7	Reserved		
		8 – 15	Inverter status, if bit 5 = 0 0x01 = Output stage inhibited 0x02 = Not enabled/not running 0x04 = Enabled/running 0x05 = Factory setting activated		High byte
		8 – 15	Inverter status if bit 5 = 1 See chapter "Error list" (→ 61)		
PI2	Actual speed	Scaling equals PO2			
PI3	Actual current	Scaling: 0x4000 = 100% (in relation to <i>P-08</i>)			

7.1.2 Communication example

The following information is sent to the inverter if:

- The digital inputs have been configured and wired properly to enable the inverter.

Description	Value	Description	
PO1	Control word	0x0000	Stop along the second deceleration ramp (<i>P-24</i>)
		0x0001	Coasting
		0x0002	Stop along the process ramp (<i>P-04</i>) or (<i>PO3</i>)
		0x0003 – 0x0005	Reserved
		0x0006	Accelerate along a ramp (<i>P-03</i>) or (<i>PO3</i>) and run at setpoint speed (<i>PO2</i>)
PO2	Setpoint speed	0x4000	= 16384 dec. = max. speed, e.g. 50 Hz (<i>P-01</i>) CW
		0x2000	= 8192 dec. = 50% of the max. speed, e.g. 25 Hz CW
		0x0000	= 0 dec. = min. speed, set in <i>P-02</i>
		0xDFFF ¹⁾	= 57343 dec. = 50% of the max. speed, e.g. 25 Hz CCW
		0xC000 ¹⁾	= 49152 dec. = max. speed, e.g. 50 Hz (<i>P-01</i>) CCW

1) Display in pair's complement

The process data sent by the inverter should look as follows during operation:

Description	Value	Description
PI1	Status word	0x0407 Status = running, output stage enabled; inverter ready, PO data enabled
PI2	Actual speed	Should correspond to PO2 (setpoint speed)
PI3	Actual current	Depends on speed and load

7.1.3 Parameter settings for the inverter

- Put the inverter into operation as described in chapter "Startup for motors" (→ 47).
- Set the following parameters, depending on the bus system used:

Parameter	SBus	CANopen	Modbus RTU
<i>P-12</i> (control source)	3, 4 ¹⁾	7, 8 ¹⁾	5, 6 ¹⁾
<i>P-14</i> (advanced parameter access)	101	101	101
<i>P-15</i> (digital input function selection)	1 ²⁾	1 ²⁾	1 ²⁾
<i>P-36/1</i> (inverter address)	1 – 63	1 – 63	1 – 63
<i>P-36/2</i> (baud rate)	Baud rate	Baud rate	Baud rate
<i>P-36/3</i> (timeout and response in event of communication failure)	t _x : Coasting after x ms r _x : Stop ramp after x ms	Communication monitoring is covered by the Lifetime function integrated in CANopen	t _x : Coasting after x ms r _x : Stop ramp after x ms

1) With ramp specified via fieldbus.

2) Default setting; for more setting options, refer to the description of parameter *P-15*.

7.1.4 Connecting the signal terminals at the inverter

For bus operation, the signal terminals can be connected according to the setting in *P-15*.

7.1.5 Establishing a CANopen/SBus network

A CAN network as depicted in the figure below should always have a linear bus structure without stub lines [1] or only with very short ones [2]. The network must have exactly one terminating resistor $R_T = 120 \Omega$ installed on both ends of the bus. The cable sets described in the catalog are available for easily establishing such a network.

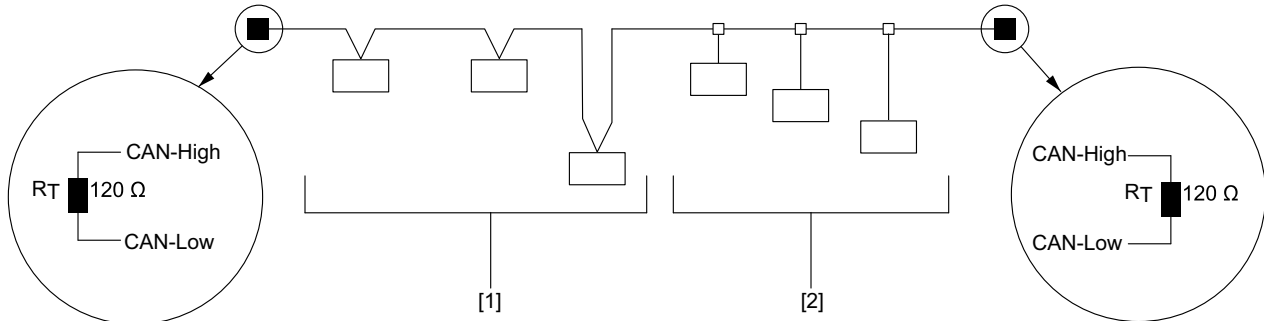

7338031755

Cable length

The permitted total cable length depends on the baud rate set in parameter *P-36/2*:

- 125 kBaud: 500 m (1640 ft)
- 250 kBaud: 250 m (820 ft)
- 500 kBaud: 100 m (328 ft)
- 1000 kBaud: 25 m (82 ft)

7.2 Connecting a gateway or controller (SBus MOVILINK®)

7.2.1 Specification

The MOVILINK® profile via CAN/SBus is an application profile from SEW-EURODRIVE specifically adjusted to SEW inverters. For detailed information, refer to the "MOVIDRIVE® MDX60B/61B Communication and Fieldbus Device Profile" manual.

To use SBus, configure the inverter as described in chapter "Parameter settings for the inverter" (→ 67).

Detailed information regarding the structure of the process data words can be found in the chapter "Structure and settings of process data words" (→ 65). There is a detailed list of all parameters including the necessary indexes as well as the scaling in chapter "Overview of parameters" (→ 79).

7.2.2 Electrical installation

Connecting gateway and MOVI-PLC®.

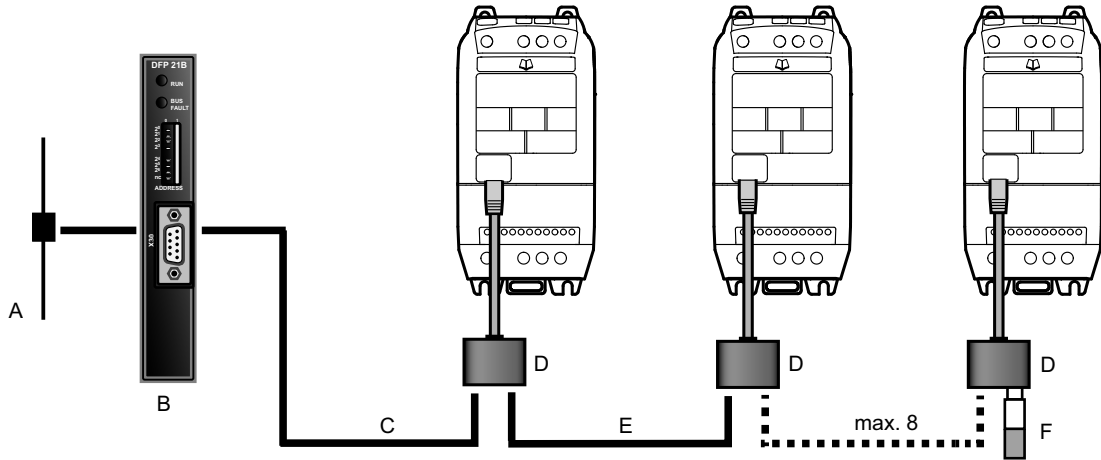

20240906123

- [A] Bus connection
- [B] Gateway, e.g. DFX/UOH
- [C] Connection cable
- [D] Splitters
- [E] Connection cable
- [F] Y connector with terminating resistor

INFORMATION



The terminating connector [F] is equipped with 2 terminating resistors and therefore establishes the terminating connection to CAN/SBus and Modbus RTU.

Instead of a terminating connector of cable set A, you can use the Y adapter of engineering cable set C. This set also includes a terminating resistor. For detailed information on the cable sets, refer to the catalog.

Wiring from the control to the Communication socket RJ45 of the inverter:

Side view	Designation	Terminal at CCU/PLC	Signal	RJ45 socket ¹⁾	Signal
	MOVI-PLC® or Gateway (DFX/UOH)	X26:1	CAN 1H	2	SBus/CAN bus h
		X26:2	CAN 1L	1	SBus/CAN bus l
		X26:3	DGND	3	GND
		X26:4	Reserved		
		X26:5	Reserved		
		X26:6	DGND		
		X26:7	DC 24 V		
	Third-party controller	X: ? ²⁾	Modbus RTU+	8	RS485+ (Modbus RTU)
		X: ? ²⁾	Modbus RTU-	7	RS485- (Modbus RTU)
		X: ? ²⁾	DGND	3	GND

1) Please observe: The terminal assignment for the socket of the inverter, not the connector, is specified above.
 2) Assignment depends on the third-party controller.

7.2.3 Startup at gateway

- Connect the gateway as described in chapter "Electrical installation" (→ 69).
- Reset all settings of the gateway to the factory setting.
- If required, set all connected inverters to SBus MOVILINK® mode as described in chapter "Parameter settings for the inverter" (→ 67). Assign unique SBus addresses (≠ 0!) and set a baud rate matching the gateway (default = 500 kBaud).
- Set DIP switch AS (auto-setup) on the DFx/UOH gateway from "OFF" to "ON" to perform an auto-setup for the fieldbus gateway.

The "H1" LED on the gateway lights up repeatedly and then goes off completely. When the "H1" LED is lit, the gateway or one of the inverters at the SBus has not been wired properly or has not been taken into operation properly.

- Refer to the relevant DFx manual for information on how to establish fieldbus communication between DFx/UOH gateway and bus master.

Monitoring sent data

The data sent via gateway can be monitored as follows:

- Using MOVITOOLS® MotionStudio via the X24 engineering interface of the gateway or optionally via Ethernet.
- Via the website of the gateway, for example to the DFE3x Ethernet gateway.
- You can check which process data are transferred with the respective parameters in parameter group 0.

7.3 Modbus RTU

The inverters support communication via Modbus RTU. Use the function "Read Holding Register (03)" for reading and the function "Write Single Register (06)" for writing. The function "Write Multiple Register (16)" is also available for PO data words 1-5. For using Modbus RTU, configure the inverter as described in chapter "Parameter settings for the inverter" (→ 67).

7.3.1 Specification

Protocol	Modbus RTU
Error checking	CRC
Baud rate	9600 bps, 19200 bps, 38400 bps, 57600 bps, 115200 bps (default)
Data format	1 start bit, 8 data bits, 1 stop bit, no parity
Physical format	RS485 2 core
User interface	RJ45

7.3.2 Electrical installation

The structure is the same as for the CAN/SBus network. The maximum number of bus nodes is 32. The permitted cable length depends on the baud rate. With a baud rate of 115200 bps and a 0.5 mm² cable, the maximum cable length is 1200 m. For the connection assignment for the RJ45 communication socket, refer to chapter "RJ45 communication socket" (→ 38).

7.3.3 Register allocation of the process data words

The process data words are allocated to the Modbus registers shown in the table.

The table below shows the default assignment of the process data words. All other parameter register assignments and the scaling of the data can be found in the tables in the "Overview of parameters" (→ 79).

Register	Upper byte	Lower byte	Command	Type
1	PO1 control word		03, 06	Read/Write
2	PO2 setpoint speed		03, 06	Read/Write
3	PO3 ramp time		03, 06	Read/Write
4	Reserved		03, 06	Read/Write
5	Reserved	–	03	Read
6	PI1 status word		03	Read
7	PI2 actual speed		03	Read
8	PI3 actual current		03	Read
9	PI4 motor torque		03	Read
...	For more registers, refer to chapter "Parameters" (→ 79).			

INFORMATION



Many bus masters address the first register as register 0. It might therefore be necessary to deduct the value "1" from the register number given below to obtain the correct register address.

7.3.4 Data flow example

In this example, the following parameters are read by the controller (PLC address base = 1):

- P-07 (rated motor voltage, Modbus register 135)
- P-08 (rated motor current, Modbus register 136)

Request master → slave (Tx)

Reading register information

Address	Function	Data				CRC check
		Start address		Number of registers		
	Read	High byte	Low byte	High byte	Low byte	crc16
01	03	00	86	00	02	crc16

Response slave → master (Rx)

Address	Function	Data				CRC check
		Number of data bytes (n)		Information n/2 register		
	Read	High byte	Low byte	Register 107/108		crc16
01	03	04		00 E6	00 2B	5B DB

Explanation of the communication example:

Tx = Send from perspective of the bus master.

Address	Device address 0x01 = 1
Function	03 read/06 write
Start address	Register start address = 0x0086 = 134
Number of registers	Number of requested registers from start address (register 135/136)
2 × CRC bytes	CRC_high, CRC_low

Rx = Received from perspective of the bus master.

Address	Device address 0x01 = 1
Function	03 read/06 write
Number of data bytes	0x04 = 4
Register 108 high byte	0x00 = 0
Register 108 low byte	0x2B = 43% of the nominal inverter current
Register 107 high byte	0x00 = 0
Register 107 low byte	0xE6 = 230 V
2 × CRC bytes	CRC_high, CRC_low

The following example describes the second process data word of the inverter (PLC address base = 1):

Process output word 2 = Modbus register 2 = setpoint speed.

Request master → slave (Tx)

Sending register information

Address	Function	Data				CRC check
		Start address		Information		
	Write	High byte	Low byte	High byte	Low byte	crc16
01	06	00	01	07	00	DB 3A

Response slave → master (Rx)

Address	Function	Data				CRC check
		Start address		Information		
	Write	High byte	Low byte	High byte	Low byte	crc16
01	06	00	01	07	00	DB 3A

Explanation of the communication example:

Tx = Send from perspective of the bus master.

Address	Device address 0x01 = 1
Function	03 read/06 write

Start address	Register start address = 0x0001 = 1 (first register to be written on = 2 PO2)
Information	0x0700 (target speed)
2 × CRC bytes	CRC_high, CRC_low

7.4 CANopen

The inverters support communication via CANopen. For using CANopen, configure the inverter as described in chapter "Parameter settings for the inverter" (→ 67).

Following a general overview of how to establish a communication connection via CANopen and the process data communication. The CANopen configuration is not described.

For detailed information on the CANopen profile, refer to the "MOVIDRIVE® MDX60B/61B Communication and Fieldbus Unit Profile" manual.

7.4.1 Specification

CANopen communication is implemented according to the specification DS301 version 4.02 of CAN in automation (see www.can-cia.de). A specific device profile, such as DS402, is not implemented.

7.4.2 Electrical installation

See chapter "Establishing a CANopen/SBus network" (→ 68).

7.4.3 COB IDs and functions in the inverter

The CANopen profile provides the following COB ID (Communication Object Identifier) and functions.

Messages and COB IDs		
Type	COB ID	Function
NMT	000h	Network management
Sync	080h	Synchronous message with dynamically configurable COB ID
Emergency	080h + device address	Emergency message with dynamically configurable COB ID
PDO1 ¹⁾ (Tx)	180h + device address	PDO (Process Data Object) PDO1 is premapped and activated by default. PDO2 is premapped and activated by default. Transmission mode (synchronous, asynchronous, event), COB ID and mapping can be configured freely.
PDO1 (Rx)	200h + device address	
PDO2 (Tx)	280h + device address	
PDO2 (Rx)	300h + device address	
SDO (Tx) ²⁾	580h + device address	SDO channel for the exchange of parameter data with the CANopen master
SDO (Rx) ²⁾	600h + device address	
Error control	700h + device control	Guarding and heartbeat functions are supported. COB ID can be set to another value.

- 1) The inverter supports up to 2 process data objects (PDO). All PDOs are "premapped" and active with transmission mode 1 (cyclical and synchronous). This means that the Tx-PDO is sent after every SYNC pulse regardless of whether the content of the Tx-PDO has changed or not.
- 2) The inverter SDO channel supports only expedited transmission. The SDO mechanisms are described in detail in the CANopen specification DS301.

INFORMATION



If speed, current, or similar values that change quickly are sent via Tx-PDO, this results in a very high load on the bus.

To limit the bus load to predictable values, you can use the inhibit time; see section "Inhibit time" in the "MOVIDRIVE® MDX60B/61B Communication and Fieldbus Device Profile" manual.

- Tx (transmit) and Rx (receive) are depicted from the perspective of the slave.

7.4.4 Supported transmission modes

The various transmission types can be selected for every process data project (PDO) in the network management (NMT).

The following transmission types are supported for Rx-PDOs:

Rx PDO transmission mode		
Transmission type	Mode	Description
0 – 240	Synchronous	The received data are transmitted to the inverter as soon as the next synchronization message is received.
254, 255	Asynchronous	The received data are transmitted to the inverter without delay.

The following transmission types are supported for Tx PDOs:

Tx PDO transmission mode		
Transmission type	Mode	Description
0	Acyclic synchronous	Tx PDO is only transmitted if the process data have changed and a SYNC object was received.
1 – 240	Cyclic synchronous	Tx PDOs are transmitted synchronously and cyclically. The transmission type indicates the number of the SYNC object required for triggering transmission of the Tx PDO.
254	Asynchronous	Tx PDOs are only transmitted when the corresponding Rx PDO has been received.
255	Asynchronous	Tx PDOs are always transmitted as soon as the PDO data has changed.

7.4.5 Default allocation plan of process data objects (PDO)

The following table shows the default mapping of the PDOs:

PDO default mapping					
	Object no.	Mapped object	Length	Mapping with default setting	Transmission type
Rx PDO1	1	2010h	Unsigned 16	PO1 control word	1
	2	2012h	Integer 16	PO2 setpoint speed	
	3	0006	Unsigned 16	Reserved	
	4	2014h	Unsigned 16	PO3 ramp time	
Tx PDO1	1	2110h	Unsigned 16	PI1 status word	1
	2	2112h	Integer 16	PI2 actual speed	
	3	2113h	Unsigned 16	PI3 actual current	
	4	2114h	Integer 16	PI4 motor torque	
Rx PDO 2	1	0006h	Unsigned 16	Reserved	1
	2	0006h	Unsigned 16	Reserved	
	3	0006h	Unsigned 16	Reserved	
	4	0006h	Unsigned 16	Reserved	
Tx PDO2	1	2118h	Unsigned 16	Status analog input 1	1
	2	2119h	Integer 16	Status analog input 2	
	3	211Ah	Unsigned 16	Status of digital inputs and outputs	
	4	2116h	Unsigned 16	Frequency inverter temperature	

INFORMATION



Tx (transmit) and Rx (receive) are depicted from perspective of the slave.

Note: Modified default settings are lost after power off and on again. This means the settings are restored to default values after power off.

7.4.6 Data flow example

Process data communication example with default setting:

	COB ID	D	DB	Word 1		Word 2		Word 3		Word 4		Description
				Byte 1	Byte 2	Byte 3	Byte 4	Byte 5	Byte 6	Byte 5	Byte 6	
1	0x701	Tx	1	"00"	–	–	–	–	–	–	–	BootUpMessage
2	0x000	Rx	2	"01"	"01"	–	–	–	–	–	–	Node start (operational)
3	0x201	Rx	8	"06"	"00"	"00"	"20"	"00"	"00"	"00"	"00"	Enable + setpoint speed
4	0x080	Rx	0	–	–	–	–	–	–	–	–	SYNC telegram
5	0x181	Tx	8	"C7"	"05"	"00"	"20"	"A2"	"00"	"28"	"00"	Process data object 1
6	0x281	Tx	8	"29"	"09"	"00"	"00"	"01"	"1F"	"AC"	"0D"	Process data object 2

After a byte swap, the table looks as follows:

	COB ID	D	DB	Word 4		Word 3		Word 2		Word 1		Description
				Byte 8	Byte 7	Byte 6	Byte 5	Byte 4	Byte 3	Byte 2	Byte 1	
1	0x701	Tx	1	–	–	–	–	–	–		"00"	BootUpMessage
2	0x000	Rx	2	–	–	–	–	–	–	"01"	"01"	Node start (operational)
3	0x201	Rx	8	"00"	"00"	"00"	"00"	"20"	"00"	"00"	"06"	Enable + setpoint speed (byte swap)
4	0x080	Rx	0	–	–	–	–	–	–	–	–	SYNC telegram
5	0x181	Tx	8	"00"	"28"	"00"	"A2"	"20"	"00"	"05"	"C7"	Process data object 1
6	0x281	Tx	8	"0D"	"AC"	"1F"	"01"	"00"	"00"	"09"	"29"	Process data object 2

Explanation of the data:

	COB ID	Explanation of the COB ID	Word 4		Word 3		Word 2		Word 1	
			Byte 8	Byte 7	Byte 6	Byte 5	Byte 4	Byte 3	Byte 2	Byte 1
1	0x701	BootUp message + device address 1	–	–	–	–	–	–	–	Placeholder
2	0x000	NMT service	–	–	–	–	–	–	Bus status	Device address
3	0x201	Rx-PDO1 + device address 1	–	–	Ramp specification		Setpoint speed		Control word	
4	0x080	SYNC telegram	–	–	–	–	–	–	–	–
5	0x181	Tx PDO1 + device address	Motor torque		Output current		Actual speed		Status word	
6	0x281	Tx PDO2 + device address	Inverter temperature		IO status		Analog input 2		Analog input 1	

Example of reading the index allocation by means of service device object (SDO):

Request controller → inverter (index: 1A00h)

Response inverter → controller: 10 00 01 21h → byte swap: 2101 00 10 h.

Explanation of the response:

→ 2101 = index in the manufacturer-specific object table

→ 00h = subindex

→ 10h = data width = 16 bit x 4 = 64 bit = 8 byte mapping length.

7.4.7 Emergency code objects

See chapter "Error list" (→ 61).

7.4.8 Table of CANopen-specific objects

CANopen-specific objects						
Index	Sub index	Function	Access	Type	PDO map	Default value
1000h	0	Device type	RO	Unsigned 32	N	0
1001h	0	Error register	RO	Unsigned 8	N	0
1002h	0	Manufacturer status register	RO	Unsigned 16	N	0
1005h	0	COB-ID Sync	RW	Unsigned 32	N	00000080h
1008h	0	Manufacturer device name	RO	String	N	"LT1B" or "LT1B"
1009h	0	Manufacturer hardware version	RO	String	N	x.xx (e.g. 1.00)
100Ah	0	Manufacturer software version	RO	String	N	x.xx (e.g. 2.00)
100Ch	0	Guard time [1 ms]	RW	Unsigned 16	N	0
100Dh	0	Life time factor	RW	Unsigned 8	N	0
1014h	0	COB-ID EMCY	RW	Unsigned 32	N	00000080h+Node ID
1015h	0	Inhibit time emergency [100 µs]	RW	Unsigned 16	N	0
1017h	0	Producer heart beat time [1 ms]	RW	Unsigned 16	N	0
1018h	0	Identity object no. of entries	RO	Unsigned 8	N	4
	1	Vendor ID	RO	Unsigned 32	N	0x00000059
	2	Product code	RO	Unsigned 32	N	Drive depended
	3	Revision number	RO	Unsigned 32	N	x.xx
	4	Serial number	RO	Unsigned 32	N	e.g. 1234/56/789
1200h	0	SDO parameter no. of entries	RO	Unsigned 8	N	2
	1	COB-ID client -> server (RX)	RO	Unsigned 32	N	00000600h+Node ID
	2	COB-ID server -> client (TX)	RO	Unsigned 32	N	00000580h+Node ID
1400h	0	RX PDO1 comms param no. of entries	RO	Unsigned 8	N	2
	1	RX PDO1 COB-ID	RW	Unsigned 32	N	40000200h+Node ID
	2	RX PDO1 transmission type	RW	Unsigned 8	N	1
1401h	0	RX PDO2 comms param no. of entries	RO	Unsigned 8	N	2
	1	RX PDO2 COB-ID	RW	Unsigned 32	N	40000300h+Node ID
	2	RX PDO2 transmission type	RW	Unsigned 8	N	1
1600h	0	RX PDO1 mapping / no. of entries	RW	Unsigned 8	N	4
	1	RX PDO1 1 st mapped object	RW	Unsigned 32	N	20100010h
	2	RX PDO1 2 nd mapped object	RW	Unsigned 32	N	20120010h
	3	RX PDO1 3 rd mapped object	RW	Unsigned 32	N	00060010h
	4	RX PDO1 4 th mapped object	RW	Unsigned 32	N	20140010h
1601h	0	RX PDO2 mapping / no. of entries	RW	Unsigned 8	N	4
	1	RX PDO2 1 st mapped object	RW	Unsigned 32	N	00060010h
	2	RX PDO2 2 nd mapped object	RW	Unsigned 32	N	00060010h
	3	RX PDO2 3 rd mapped object	RW	Unsigned 32	N	00060010h
	4	RX PDO2 4 th mapped object	RW	Unsigned 32	N	00060010h
1800h	0	TX PDO1 comms param no. of entries	RO	Unsigned 8	N	3
	1	TX PDO1 COB-ID	RW	Unsigned 32	N	40000180h+Node ID
	2	TX PDO1 transmission type	RW	Unsigned 8	N	1
	3	TX PDO1 Inhibit time [100 µs]	RW	Unsigned 16	N	0
1801h	0	TX PDO2 comms param no. of entries	RO	Unsigned 8	N	3
	1	TX PDO2 COB-ID	RW	Unsigned 32	N	40000280h+Node ID
	2	TX PDO2 transmission type	RW	Unsigned 8	N	1
	3	TX PDO2 Inhibit time [100 µs]	RW	Unsigned 16	N	0
1A00h	0	TX PDO1 mapping / no. of entries	RW	Unsigned 8	N	4
	1	TX PDO1 1 st mapped object	RW	Unsigned 32	N	21100010h
	2	TX PDO1 2 nd mapped object	RW	Unsigned 32	N	21120010h
	3	TX PDO1 3 rd mapped object	RW	Unsigned 32	N	21130010h
	4	TX PDO1 4 th mapped object	RW	Unsigned 32	N	21140010h

29135451/EN – 01/2020

CANopen-specific objects						
Index	Sub index	Function	Access	Type	PDO map	Default value
1A01h	0	TX PDO2 mapping / no. of entries	RW	Unsigned 8	N	4
	1	TX PDO2 1 st mapped object	RW	Unsigned 32	N	21180010h
	2	TX PDO2 2 nd mapped object	RW	Unsigned 32	N	21190010h
	3	TX PDO2 3 rd mapped object	RW	Unsigned 32	N	211A0010h
	4	TX PDO2 4 th mapped object	RW	Unsigned 32	N	21160010h

7.4.9 Table of manufacturer-specific objects

The manufacturer-specific objects of the frequency inverter are defined as follows:

Manufacturer-specific objects						
Index	Subindex	Function	Access	Type	PDO map	Note
2000h	0	Reserved	RW	Unsigned 16	Y	Read as 0, writing not possible
2001h – 200Fh	0	Reserved	RW	Unsigned 16	Y	Read as 0, writing not possible
2010h	0	Control command register	RW	Unsigned 16	Y	SBus control word format
2011h	0	Speed reference (RPM)	RW	Integer 16	Y	1 = 0.2 min ⁻¹
2012h	0	Speed reference (percentage)	RW	Integer 16	Y	4000HEX = 100% P-01
2013h	0	Reserved	RW	Integer 16	Y	Read as 0, writing not possible
2014h	0	User ramp reference	RW	Unsigned 16	Y	1 = 1 ms (reference to 50 Hz)
2015h – 2100h	0	Reserved	RW	Unsigned 16	Y	Read as 0, writing not possible
2101h – 210Fh	0	Reserved	RO	Unsigned 16	Y	Read as 0
2110h	0	Drive status register	RO	Unsigned 16	Y	SBus status word format
2111h	0	Motor speed (RPM)	RO	Integer 16	Y	1 = 0.2 min ⁻¹
2112h	0	Motor speed (percentage)	RO	Integer 16	Y	4000HEX = 100% of P-01
2113h	0	Motor current	RO	Unsigned 16	Y	4000HEX = 100% of P-08
2114h	0	Motor torque	RO	Integer 16	Y	1000DEC = Motor rated torque
2115h	0	Motor power	RO	Unsigned 16	Y	1000DEC = Drive rated power
2116h	0	Drive temperature	RO	Integer 16	Y	1DEC = 0.01 °C
2117h	0	DC bus value	RO	Unsigned 16	Y	1DEC = 1 V
2118h	0	Analog input 1	RO	Integer 16	Y	1000HEX = Full scale
2119h	0	Analog input 2	RO	Integer 16	Y	1000HEX = Full scale
211Ah	0	Digital input & output status	RO	Unsigned 16	Y	LB= input; HB = output
211Bh	0	Analog output 1 (percentage)	RO	Unsigned 16	Y	1000 DEC = 100.0%
211Ch – 2120h	0	Reserved	RO	Unsigned 16	Y	Read as 0
2121h	0	Scope channel 1 (internal format)	RO	Unsigned 16	Y	
2122h	0	Scope channel 2 (internal format)	RO	Unsigned 16	Y	
2123h	0	Scope channel 3 (internal format)	RO	Unsigned 16	Y	
2124h	0	Scope channel 4 (internal format)	RO	Unsigned 16	Y	
2AF8h ¹⁾	0	SBus parameter start index	RO	–	N	11000d
–	0	SBus parameters	RO/RW	–	N	–
2C6Fh ¹⁾	0	SBus parameter end index	RW	–	N	11375d

1) Objects 2AF8h – 2C6EF correspond with SBus parameter indexes 11000d – 11375d; some of them are read-only.

8 Parameters

8.1 Overview of parameters

8.1.1 Configuration parameters

Parameter	CANopen/ SBus index	Modbus register	Description	Display range	Explanation
P00	–	–	Configuration parameters for IP66/ NEMA-4X devices with switch option	SEt-1 – SEt-8	"P-00 Configuration parameters for IP66/NEMA-4X devices with switch option" (→ 112)

8.1.2 Parameters for realtime monitoring (read only)

Parameter group 0 gives access to internal inverter parameters for monitoring purposes. These parameters cannot be changed.

Parameter group 0 is visible when *P-14* is set to "101".

Access to parameter group 0

- Press the <Menu> button for 2 s to access the parameter menu.
- Set *P-14* to "101" or, if there is a user-defined password, to the value from *P-37*.
- Use the <Up> or <Down> key to set the *P-00* parameter value.
- Press the <Menu> button for 1 s to switch to the *P00-xy* parameter group.
- Use the <Up> or <Down> key to select the desired parameter.
- Press the <Menu> key again for 1 s to display the value (<Up>/<Down> key for several levels)
- To return to the parameter menu, press the <Menu> key for 1 s.
- To exit the parameter menu, press the <Menu> key for 2 s.

Description of parameter group 0

Parameter	CANopen/ SBus index	Modbus register	Description	Display range	Explanation
P00-01	11210	20	Value of analog input 1	0 – 100%	Index value 1000 = 100% ± max. input voltage or input current.
P00-02	11211	21	Value of analog input 2	0 – 100%	Index value 1000 = 100% ± max. input voltage or input current.
P00-03	11213	22, 40	Speed controller setpoint	P-02 – P-01	Speed display in Hz when $P-10 = 0$, otherwise in min^{-1} .
P00-04	11212	11	Status of the digital inputs	Binary value	Status of the digital inputs DI1; DI2; DI3; DI4.
P00-05	11232	39	Control electronics temperature	-25° C – 125° C	40 = 40 °C.
P00-06	11288		DC link voltage ripple	0 – 1000 V	DC link voltage ripple.
P00-07	11270	43	Present motor voltage	AC 0 – 600 V	Inverter output voltage rms value.
P00-08	11220	23	DC link voltage ($U_{\text{DC link}}$)	DC 0 – 1000 V	600 = 600 V (internal DC link voltage).
P00-09	11221	24	Power electronics/heat sink temperature	-20 °C – 100 °C	40 = 40 °C.
P00-10	11296 – 11297	25, 26	Operating hours counter (inverter enabled)	Value 1: Hours Value 2: Minutes, seconds	General enable of the inverter since manufacture (enable). Value cannot be reset.
P00-11	11298 – 11299	–	Runtime since the last error 1	Value 1: Hours Value 2: Minutes, seconds	Operating time since the last error or power off. The timer is reset when there is another enable or power off.
P00-12	11300 – 11301	–	Runtime since the last error 2	Value 1: Hours Value 2: Minutes, seconds	Operating time since the last error. The timer is reset when there is another enable or power off.
P00-13	11302 – 11303	28	Operating time since the last enable	Value 1: Hours Value 2: Minutes, seconds	Displays the operating time of an enable interval. The timer is reset at each following enable.
P00-14	11350	–	Current PWM switching frequency	2 – 16 kHz	The value may be below the setting in $P-17$, as it is automatically reduced by the inverter in the event of thermal overload.
P00-15	11305 – 11313	–	DC link voltage protocol	8 values 0 – 1000 V	Displays the last 8 values prior to the switch off with error.
P00-16	11322 – 11329	–	Power electronics/heat sink temperature protocol (P00-09)	8 values -20 °C – 120 °C	Displays the last 8 values prior to the switch off with error.
P00-17	11330 – 11337	–	Motor current protocol	8 values 0 – 2 × nominal motor current	Displays the last 8 values prior to the switch off with error.
P00-18	11247 – 11250	15, 16	Firmware version and checksum	4 values, e.g.: "1 2.01", "1 1703" "2 2.01", "2 ECdA"	Firmware and checksum of the control electronics and the power section.
P00-19	11251 – 11254	34 – 37	Serial number	2 values xxxxxx xx-xxx	Serial number of the inverter.
P00-20	11255	12 – 14, 17	Inverter type	3 values, e.g.: 0.75/F1 230/3P-out	Power rating/connection and voltage/motor connection.
P00-21	11259 – 11261	–	Outgoing process data (CANopen, SBus)	4 values: PO1 – PO4	4 entries; outgoing process data from the perspective of the controller.
P00-22	11256 – 11258	–	Incoming process data (CANopen, SBus)	4 values: PI1 – PI4	4 entries; incoming process data from the perspective of the controller.
P00-23	11289 – 11290	–	Total runtime > 85 °C (power electronics/heat sink)	Value 1: Hours Value 2: Minutes, seconds	Time during which a temperature of > 85 °C was measured at the heat sink.

Parameter	CANopen/ SBus index	Modbus register	Description	Display range	Explanation
P00-24	11237 – 11238	–	Total runtime > 60 °C (control electronics)	Value 1: Hours Value 2: Minutes, seconds	Time during which the inverter was operated at > 60 °C.
P00-25	11291	–	Rotor speed (calculated via motor model)	Hz/min-1	Speed display in Hz when $P-10 = 0$, otherwise in min^{-1} .
P00-26	11292 – 11293	32, 33	kWh counter/MWh counter	kWh/MWh	The values are reset during factory setting.
P00-27	11304 – 11305	–	Runtime of inverter fan	Value 1: Hours Value 2: Minutes, seconds	Runtime clock for internal fan.
P00-28	11272 – 11281	–	Error log	4 values	Shows the last 4 errors. You can toggle between subitems by pressing the <Up>/<Down> keys.
P00-29	11219	–	PI controller output	0 – 100%	PI controller output.
P00-30	11314 – 11321	–	DC link voltage ripple protocol	8 values 0 – 1000 V	Displays the last 8 values prior to the switch off with error.
P00-31	11282 – 11283	–	Magnetizing current (Id) and torque current (Iq)	2 values d x.xA q x.xA	Magnetizing current/torque-building current.
P00-32	11239 – 11246	–	Power electronics temperature protocol (P00-05)	8 values -25 °C – 125 °C	Displays the last 8 values prior to the switch off with error.
P00-33	11338	–	Counter for overcurrent errors: O-I	0 – 65000	Counter for overcurrent errors.
P00-34	11339	–	Counter for overvoltage errors: O-Volt	0 – 65000	Counter for overvoltage errors.
P00-35	11340	–	Counter for undervoltage errors: U-Volt	0 – 65000	Counter for undervoltage errors. Also during power off.
P00-36	11341	–	Counter for overtemperature errors: O-t	0 – 65000	Counter for overtemperature errors at the heat sink.
P00-37	11342	–	Counter for braking resistor overload: OL-b	0 – 65000	Counter for short-circuit errors at the brake chopper.
P00-38	11343	–	Counter for overtemperature errors: O-heat	0 – 65000	Counter for overtemperature errors due to high ambient temperature.
P00-39	11224	–	Counter for Modbus communication errors	0 – 65000	
P00-40	11225	–	Counter for CANopen communication errors	0 – 65000	
P00-41	11223	–	Counter for internal I/O communication errors	0 – 65000	
P00-42	11344	–	Counter for internal DSP communication errors power section.	0 – 65000	Counter for communication errors between the processors of the power electronics.
P00-43	11351 – 11352	–	Operating hours counter (inverter to line voltage)	Value 1: Hours Value 2: Minutes, seconds	Total switch-on time of the inverter since manufacture (supply system on). Value cannot be reset.
P00-44	–	–	Current phase offset and reference value for U	Internal value	Value 1: Reference value. Value 2: Measured value.
P00-45	–	–	Current phase offset and reference value for V	Internal value	Value 1: Reference value. Value 2: Measured value.

29135451/EN – 01/2020

Parameter	CANopen/ SBus index	Modbus register	Description	Display range	Explanation
P00-46	–	–	Current phase offset and reference value for W	Internal value	Value 1: Reference value. Value 2: Measured value.
P00-47	11294 – 11295	–	Total switch-on duration in fire mode	Value 1: Hours Value 2: Minutes, seconds	Total cyclic duration factor of the fire mode in [h].
P00-48	11226 – 11227	18, 19	Display values channel 1 and 2 internal oscilloscope	Channel 1 Channel 2	Current value of the latest oscilloscope measurement. Unit refers to the set size.
P00-49	11228 – 11229	–	Display values channel 3 and 4 internal oscilloscope	Channel 3 Channel 4	Current value of the latest oscilloscope measurement. Unit refers to the set size.
P00-50	11355 – 11356	–	Lib version and DSP bootloader version for motor controller	Value 1: L 3.04 Value 2: b 1.00	Value 1: Version of the motor controller Value 2: DSP bootloader version.

8.1.3 Basic parameters

Parameter	CANopen/ SBus index	Modbus register	Description	Setting range Factory setting
P-01	11020	129	Maximum speed (→ 85)	$P-02 - 50.0 \text{ Hz} - 5 \times P-09^{1)}$
P-02	11021	130	Minimum speed (→ 85)	$0 - P-01 \text{ Hz}^{1)}$
P-03	11022	131	Acceleration ramp time (→ 85)	0.00 – 5.0 – 600 s
P-04	11023	132	Deceleration ramp time (→ 85)	0.00 – 5.0 – 600 s
P-05	11024	133	Stop mode (→ 86)	0 – 2
P-06	11025	134	Energy-saving function (→ 86)	0 – 1
P-07	11012	135	Rated motor voltage (→ 86)	0 – 230 – 250 V 0 – 400 ²⁾ – 500 V
P-08	11015	136	Rated motor current (→ 87)	20 – 100%
P-09	11009	137	Rated motor frequency (→ 87)	25 – 50/60 ²⁾ Hz – 500 Hz
P-10	11026	138	Rated motor speed (→ 87)	0 – 30 000 min ⁻¹
P-11	11027	139	Voltage increase, boost (→ 88)	0 – 25% ³⁾
P-12	11028	140	Control signal source (→ 88)	0 – 11
P-13	11029	141	Reserved	–
P-14	11030	142	Advanced parameter access (→ 89)	0 – 9999

1) Note the explanation under P-10.

2) 460 V in American version only

3) Power-dependent.

8.1.4 Advanced parameters

Parameter	CANopen/ SBus index	Modbus register	Description	Setting range Factory setting
P-15	11031	143	Digital input function selection (→ 108)	0 – 13
P-16	11064	144	Analog input 1 format (→ 109)	U0 – 10 b0 – 10 A0 – 20 t4 – 20 r4 – 30 t20 – 4 r20 – 4
P-17	11003	145	PWM switching frequency (→ 109)	2 – 4 – 16 kHz ¹⁾
P-18	11050	146	User relay output function selection (→ 109)	0 – 1 – 8
P-19	11051	147	Limit value for relay/analog output (→ 109)	0.0 – 100.0 – 200.0%
P-20	11036	148	Fixed setpoint speed 1 (→ 109)	-P-01 – 5.0 Hz – P-01 ²⁾
P-21	11037	149	Fixed setpoint speed 2 (→ 109)	-P-01 – 25.0 Hz – P-01 ²⁾
P-22	11038	150	Fixed setpoint speed 3 (→ 109)	-P-01 – 40.0 Hz – P-01 ²⁾
P-23	11039	151	Fixed setpoint speed 4 (→ 109)	-P-01 – P-01²⁾
P-24	11059	152	Second deceleration ramp, rapid stop ramp (→ 109)	0.00 – 2.0 – 25 s
P-25	11046	153	Analog output/digital output function selection (→ 109)	0 – 8 – 10
P-26	11045	154	Skip frequency band (→ 109)	0 Hz – P-01 ²⁾
P-27	11044	155	Skip frequency (→ 109)	P-02 – P-01 ²⁾
P-28	11099	156	V/f characteristic curve adjustment (voltage value) (→ 110)	0 – P-07 [V]
P-29	11098	157	V/f characteristic curve adjustment (frequency value) (→ 110)	0 – P-09 [Hz]
P-30	11070	158	Start mode selection (→ 110)	Edge-r, Auto-0 – Auto-5
P-31	11071	159	Keypad/fieldbus enabling behavior (→ 110)	0 – 1 – 7
P-32	11133	160	Direct current hold function Level 1: Current holding time (→ 110)	0.0 – 25 s
	11132		Direct current hold function Level 2: Current hold mode (→ 110)	0 – 2
P-33	11060	161	Enable flying start function (→ 110)	0 – 2
P-34	11131	162	Activation of brake chopper (→ 110)	0 – 2
P-35	11065	163	Analog input 1/slave scaling (→ 110)	0.0 – 100.0 – 2000%
P-36	11105	164	Fieldbus setting Level 1: Inverter address (→ 110)	0 – 1 – 63
	11106		Fieldbus setting Level 2: Baud rate (→ 110)	0 – 1 – 5
	11107		Fieldbus setting Level 3: Timeout behavior (→ 110)	0 – 8
P-37	11074	165	Advanced parameter access code definition (→ 110)	0 – 101 – 9999
P-38	11073	166	Parameter lock (→ 110)	0 – 1
P-39	11066	167	Analog input 1 offset (→ 110)	-500 – 0.0 – 500 %
P-40	11056	168	Actual display value scaling factor Level 1: Display scaling factor (→ 110)	0.000 – 16.000
	11057		Actual display value scaling factor Level 2: Display scaling source (→ 110)	0 – 2
P-41	–	169	Thermal motor protection to UL508C (→ 110)	0 – 1
P-42	11075	170	PI proportional gain (→ 110)	0.0 – 1.0 – 30.0
P-43	11076	171	PI-integrating time constant (→ 110)	0.0 – 1.0 – 30.0 s
P-44	11078	172	PI operating mode (→ 110)	0 – 1
P-45	11079	173	PI reference selection Level 1: PI reference source (→ 110)	0 – 1
	11080		PI reference selection Level 2: PI feedback source (→ 110)	0 – 5

Parameter	CANopen/ SBus index	Modbus register	Description	Setting range Factory setting
P-46	11081	174	PI fixed setpoint reference (→ 107)	0.0 – 100.0%
P-47	11067	175	Analog input 2 format (→ 108)	U0 – 10 A0 – 20 t4 – 20 r4 – 30 t20 – 4 r20 – 4 Ptc – th
P-48	11061	176	Standby mode (→ 108)	0.0 – 25 s
P-49	11087	177	PI control difference wake-up level (→ 108)	0.0 – 5.0 – 100 %
P-50	11052	178	Hysteresis band user relay (→ 108)	0.0 – 100 %
P-51	11089	179	Operating mode/motor control (→ 109)	0 – 1 – 5
P-52	11090	180	Auto tune (→ 109)	0 – 1
P-53	11091	181	Speed controller Level 1: Proportional gain	0 – 250 %
	11092		Speed controller Level 2: Integrating time constant	0.00 – 2.50 s
P-54	11095	182	Current limit (→ 110)	0.1 – 150 – 175 %
P-55	11140	183	Motor stator resistance (Rs) (→ 111)	0.00 – 655.35 Ω
P-56	11142	184	Motor stator inductance (Lsd) (→ 111)	0.0 – 6553.5 mH
P-57	11145	185	Motor stator inductance (Lsq) (→ 111)	0.0 – 6553.5 mH
P-58	11134	186	Speed of direct current braking (→ 112)	0.0 – <i>P-01</i>
P-59	11135	187	Current strength of direct current braking (→ 112)	0.0 – 20.0 – 100%
P-60	11128	188	Fire mode/emergency mode speed (→ 112)	<i>-P-01</i> – 0 – <i>P-01</i> Hz

1) Power-dependent.

2) Note the explanations under P-10.

8.2 Explanation of the parameters

8.2.1 Basic parameters

P-01 Maximum speed

Setting range: $P-02 - 50.0 \text{ Hz} - 5 \times P-09$ (maximum 500 Hz)

Specifies the upper limit for the frequency (speed) that can be applied to the motor in any operating mode. This parameter is shown in Hz if the factory settings are used or if the parameter for the rated speed of the motor ($P-10$) is zero. If the rated motor speed was entered in min^{-1} in $P-10$, this parameter will be displayed in rpm.

The maximum speed is also limited by the switching frequency set in $P-17$. The limit is determined by the maximum output frequency to the motor = $P-17: 16$.

P-02 Minimum speed

Setting range: $0 - P-01 \text{ Hz}$

Specifies the lower limit for the frequency (speed) that can be applied to the motor in any operating mode. This parameter is shown in Hz if the factory settings are used or if the parameter for the rated speed of the motor ($P-10$) is zero. If the rated motor speed was entered in min^{-1} in $P-10$, this parameter will be displayed in rpm.

The speed drops below this limit only when the inverter enable signal is removed and the inverter decreases the output frequency to zero.

P-03 Acceleration ramp time

Setting range: $0.00 - 5.0 - 600 \text{ s}$

Specifies the time in seconds during which the output frequency (speed) increases from 0 to 50 Hz. Note that the ramp time is not affected by changing either the maximum or minimum speed limit. The reason is that the ramp time refers to 50 Hz, not to the speed $P-01/P-02$.

P-04 Deceleration ramp time

Setting range: $0.00 - 5.0 - 600 \text{ s}$

Specifies the time in seconds during which the output frequency (speed) decreases from 50 to 0 Hz. Note that the ramp time is not affected by changing either the maximum or minimum speed limit. The reason is that the ramp time refers to 50 Hz, not to $P-01/P-02$.

P-05 Stop mode

Defines the delay behavior of the drive for normal operation and power failure.

Setting range: **0** – 2

In the event of power failure:

- 0: Operation continues
- 1: Motor coasts to a halt
- 2: Rapid stop along *P-24*

Normal stop:

- 0: Stop along ramp *P-04*
- 1: Motor coasts to a halt
- 2: Stop along ramp *P-04*

If *P-05* = 0, the frequency inverter attempts to continue operation in the case of a power failure by reducing the motor speed and using the load as a generator.

P-06 Energy-saving function

- **0: Off**
- 1: On

If this function is activated, the inverter continuously monitors the motor load condition by comparing the output current with the nominal motor current. If the motor rotates with a constant speed in the partial load range, the inverter automatically reduces the output voltage, thus reducing the motor's energy consumption. This reduces the energy consumption of the motor. If the motor load increases or the frequency setpoint changes, the output voltage increases immediately. The energy-saving function works only if the inverter setpoint remains constant over a certain period of time.

Application examples include, for example, fan applications or conveyor belts for which the energy requirement in the range between full, empty or partial load trips is optimized.

This function is only applicable for asynchronous motors.

P-07 Rated motor voltage

Setting range:

- 230 V inverter: 20 – **230** – 250 V
- 400 V inverter: 20 – **400/460¹⁾** – 500 V

Specifies the nominal voltage of the motor connected to the inverter (in accordance with the motor nameplate). The parameter value is used in V/f speed control for controlling the output voltage applied to the motor. In V/f speed control, the output voltage of the inverter amounts to the value set in *P-07* if the output speed corresponds to the motor base frequency set in *P-09*.

"0V" = DC link compensation is disabled. When braking, the V/f ratio shifts as a result of the voltage increase in the DC link, resulting in greater motor losses. The motor heats up more. The additional motor losses during braking might make a braking resistor redundant.

1) 460 V in American version only.

P-08 Rated motor current

Setting range: 20 – 100% of the inverter output current. Is given as absolute value in ampere.

Specifies the rated current of the motor connected to the inverter (according to the motor nameplate). This allows the inverter to match its internal thermal motor protection (I x t protection) to the motor.

If the inverter output current is > 100% of the nominal motor current, the inverter switches off the motor after a certain amount of time (I.-trP) before there is any thermal damage to the motor.

P-09 Rated motor frequency

Setting range: 25 – 50/60¹⁾ – 500 Hz

Specifies the rated frequency of the motor connected to the inverter (according to the motor nameplate). This is the frequency at which the maximum (rated) output voltage is applied to the motor. Above this frequency, the voltage applied to the motor remains constant at its maximum value.

1) 60 Hz (American version only).

P-10 Rated motor speed

Setting range: 0 – 30 000 min⁻¹

Specifies the rated speed of the motor. When the parameter is ≠ 0, all speed-related parameters such as minimum and maximum speed are displayed in "min⁻¹".

The slip compensation is activated at the same time. The frequency or speed shown on the display of the inverter corresponds to the calculated rotor frequency or rotor speed.

P-11 Voltage increase, boost

Setting range: 0 – 25% of the max. output voltage. Resolution 0.1%

- Size 1: max. 25%
- Size 2: max. 20%
- Size 3: max. 15%
- Size 4: max. 10%

Increases the output voltage of the frequency inverter by a scalable value (in case of low speed) to obtain a higher motor torque generation in this speed range.

Vector operation ($P51 \neq 1$): $P-11$ is automatically filled by the auto tune process, if one of the vector control modes was selected in $P-51$.

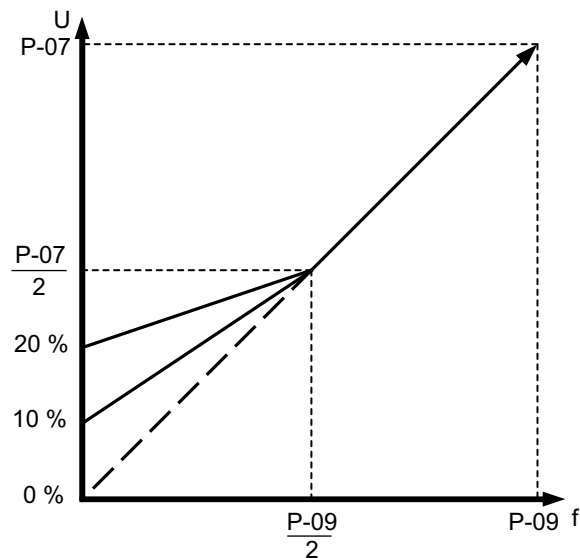

6353342859

A motor with forced cooling fan must be used for continuous duty at low speeds.

P-12 Control signal source

Setting range: 0 – 11

- **0: Terminal mode**
- 1: Keypad mode unipolar
- 2: Keypad mode bipolar
- 3: SBus MOVILINK® (with internal ramps $P-03$ and $P-04$)
- 4: SBus MOVILINK® (with ramps via process output data word 3)
- 5: Modbus RTU (with internal ramps $P-03$ and $P-04$)
- 6: Modbus RTU (with ramps via process output data word 3)
- 7: CANopen (with internal ramps $P-03$ and $P-04$)
- 8: CANopen (with ramps via process output data word 3)
- 9: PI controller mode
- 10: PI controller mode with addition of the analog input 1
- 11: Slave mode

P-13 Reserved

Parameter reserved

P-14 Extended parameter access

Setting range: **0** – 9999

This parameter allows access to all parameters. Access is possible when the following values are valid.

- **0: P-01 – P-15** (basis parameter)
- **101: P-01 – P-60** (extended parameters)

The password (101) is defined in parameter *P-37* and can be changed in a user-defined way.

8.2.2 Advanced parameters

P-15 Digital input function selection

Setting range: **0** – 13

Users can configure the function of the digital inputs of the inverter, that is the user can select functions required for the application.

The following tables list the functions of the digital inputs depending on the value set in parameters *P-12* (*terminal/keypad/SBus control*) and *P-15* (*selection of the digital input functions*).

Terminal mode

INFORMATION



An error reset can be performed using a rising edge: at digital input 1.

When parameter $P-12 = 0$ (terminal mode), the following table applies:

P-15	Digital input 1	Digital input 2	Digital input 3/ Analog input 2	Analog input 1/ Digital input 4	Comments
0	0: Stop 1: Enable + start	0: Clockwise rotation 1: Counterclockwise rotation	0: Speed setpoint, analog 1: Fixed setpoint speed 1	Speed setpoint, analog	–
1	0: Stop 1: Enable + start	0: Speed setpoint, analog 1: Fixed setpoint speed 1, 2	0: Fixed setpoint speed 1 1: Fixed setpoint speed 2	Speed setpoint, analog	–
2	0: Stop 1: Enable + start	0: Open	0: Open	0: Fixed setpoint speed 1 – 4 1: Max. speed (P-01)	Fixed setpoint speed 1
		1: Closed	0: Open		Fixed setpoint speed 2
		0: Open	1: Closed		Fixed setpoint speed 3
		1: Closed	1: Closed		Fixed setpoint speed 4
3	0: Stop 1: Enable + start	0: Speed setpoint, analog 1: Fixed setpoint speed 1	External error 0: Error 1: No error	Speed setpoint, analog	When using a TF/TH, you must also set P-47 to "Pct-th".
4	0: Stop 1: Enable + start	0: Clockwise rotation 1: Counterclockwise rotation	0: Speed setpoint, analog 1: Fixed setpoint speed 1	Speed setpoint, analog	–
5	0: Stop 1: Enable + start CW rotation	0: Stop 1: Enable + start CCW rotation	0: Speed setpoint, analog 1: Fixed setpoint speed 1	Speed setpoint, analog	–
	When both inputs are active, the stop ramp (P-24) is activated.				
6	0: Stop 1: Enable + start	0: Clockwise rotation 1: Counterclockwise rotation	External error 0: Error 1: No error	Speed setpoint, analog	When using a TF/TH, you must also set P-47 to "Pct-th".
7	0: Stop 1: Enable + start CW rotation	0: Stop 1: Enable + start CCW rotation	External error 0: Error 1: No error	Speed setpoint, analog	When using a TF/TH, you must also set P-47 to "Pct-th".
	When both inputs are active, the rapid stop ramp (P-24) is activated.				
8	0: Stop 1: Enable + start	0: Clockwise rotation 1: Counterclockwise rotation	0: Open	0: Open	Fixed setpoint speed 1
			1: Closed	0: Open	Fixed setpoint speed 2
			0: Open	1: Closed	Fixed setpoint speed 3
			1: Closed	1: Closed	Fixed setpoint speed 4
9	0: Stop 1: Enable + start CW rotation	0: Stop 1: Enable + start CCW rotation	0: Open	0: Open	Fixed setpoint speed 1
			1: Closed	0: Open	Fixed setpoint speed 2
			0: Open	1: Closed	Fixed setpoint speed 3
			1: Closed	1: Closed	Fixed setpoint speed 4
When both inputs are active, the rapid stop ramp (P-24) is activated.					
10	Enable + start pushbutton (NO contact)	Stop pushbutton (NC contact)	0: Speed setpoint, analog 1: Fixed setpoint speed 1	Speed setpoint, analog	Edge controller
11	Enable + start pushbutton, CW rotation (NO contact)	Stop pushbutton (NC contact)	Enable + start pushbutton CCW rotation (NO contact)	Speed setpoint, analog	When DI1 and DI3 are active simultaneously, the rapid stop ramp (P-24) is activated.
12	0: Stop 1: Enable + start	0: Rapid stop ramp P-24 1: Operation	0: Speed setpoint, analog 1: Fixed setpoint speed 1	Speed setpoint, analog	–
13	0: Stop 1: Enable + start	0: Fixed setpoint speed 1 1: Speed setpoint, analog	0: Emergency mode/fire mode 1: Normal operation	Speed setpoint, analog	Fire mode/emergency mode



Keypad mode

INFORMATION



The enable/start behavior always depends on the setting made in *P-31*.

When parameter *P-12* = 1 or 2 (keypad mode), the following table applies.

P-15	Digital input 1	Digital input 2	Digital input 3/ Analog input 2	Analog input 1/ Digital input 4	Comments	<Up> key 	<Down> key 
0, 5, 8-12	0: Stop 1: Enable	Speed pushbutton up (NO contact) Pressing both pushbuttons simultaneously starts/enables the drive.	Speed pushbutton down (NO contact)	0: Clockwise rotation 1: Counterclockwise rotation	–	Increase speed	Reduce speed
1	0: Stop 1: Enable	No function	PI controller function depending on <i>P-45</i>		–	No function	No function
2	0: Stop 1: Enable	Speed pushbutton up (NO contact) Pressing both pushbuttons simultaneously starts/enables the drive.	Speed pushbutton down (NO contact)	0: Speed setpoint keypad 1: Fixed setpoint speed 1	–	Increase speed	Reduce speed
3	0: Stop 1: Enable	Speed pushbutton up (NO contact)	External error 0: Error 1: No error	Speed pushbutton down (NO contact)	When using a TF/TH, you must also set <i>P-47</i> to "Ptc-th".	Increase speed	Reduce speed
4	0: Stop 1: Enable	Speed pushbutton up (NO contact)	0: Speed setpoint keypad 1: Speed setpoint, analog	Speed setpoint, analog	–	Increase speed	Reduce speed
6	0: Stop 1: Enable	0: Clockwise rotation 1: Counterclockwise rotation	External error 0: Error 1: No error	0: Speed setpoint keypad 1: Fixed setpoint speed 1	When using a TF/TH, you must also set <i>P-47</i> to "Ptc-th".	Increase speed	Reduce speed
7	0: Stop 1: Enable CW rotation When both inputs are active, the rapid stop ramp (<i>P-24</i>) is activated.	0: Stop 1: Enable CCW rotation	External error 0: Error 1: No error	0: Speed setpoint keypad 1: Fixed setpoint speed 1	When using a TF/TH, you must also set <i>P-47</i> to "Ptc-th".	Increase speed	Reduce speed
13	0: Stop 1: Enable	0: Fixed setpoint speed 1, 2 1: Speed setpoint keypad	0: Emergency mode/ fire mode 1: Normal operation	0: Fixed setpoint speed 1 1: Fixed setpoint speed 2	Fire mode/ emergency mode	Increase speed	Reduce speed

SBus, CANopen, Modbus-RTU, and slave control mode

INFORMATION



The enable/start behavior always depends on the setting made in *P-31*.

The hardware enable is the prerequisite for the fieldbus enable.

The setpoint changeover (DI2) functions on the SBus only in combination with the hardware enable (DI1) and the fieldbus enable.

The setpoint changeover (DI2) functions also in the case of CAN, Modbus/RTU, and slave mode only with the hardware enable (DI1), without an imminent fieldbus enable.

When parameter *P-12* = 3 or 4 (SBus control mode), the following table applies:

P-15	Digital input 1	Digital input 2	Digital input 3	Analog input	Comments
0, 2, 4, 8 – 12	0: Stop 1: Enable	No function	No function	No function	–
1	0: Stop 1: Enable	No function	PI controller function depending on <i>P-45</i>		–
3	0: Stop 1: Enable	0: Fieldbus/master speed setpoint 1: Fixed setpoint speed 1	External error 0: Error 1: No error	No function	When using a TF/TH, you must also set <i>P-47</i> to "Ptc-th".
5	0: Stop 1: Enable	0: Fieldbus/master speed setpoint 1: Fixed setpoint speed 1, 2	0: Fixed setpoint speed 1 1: Fixed setpoint speed 2	No function	–
6	0: Stop 1: Enable	0: Fieldbus/master speed setpoint 1: Speed setpoint, analog	External error 0: Error 1: No error	Speed setpoint, analog	When using a TF/TH, you must also set <i>P-47</i> to "Ptc-th".
7	0: Stop 1: Enable	0: Fieldbus/master speed setpoint 1: Speed setpoint keypad	External error 0: Error 1: No error	No function	When using a TF/TH, you must also set <i>P-47</i> to "Ptc-th".
13	0: Stop 1: Enable	0: Fixed setpoint speed 1, 2 1: Fieldbus/master speed setpoint	0: Emergency mode/fire mode 1: Normal operation	0: Fixed setpoint speed 1 1: Fixed setpoint speed 2	Fire mode/emergency mode

PI controller control mode

P-15	Digital input 1	Digital input 2	Digital input 3/ Analog input 2	Analog input 1/ Digital input 4	Comments
0, 2, 9 – 12	0: Stop 1: Enable + start	0: PI controller 1: Fixed setpoint speed 1	See comments	See comments	The setpoint and actual value sources of the PI controller must be set via P-45 Level 1 and 2.
1	0: Stop 1: Enable + start	0: PI controller 1: Setpoint source analog input 1	See comments	See comments	
3, 7	0: Stop 1: Enable + start	0: PI controller 1: Fixed setpoint speed 1	External error 0: Error 1: No error	See comments	The setpoint and actual value sources of the PI controller must be set via P-45 Level 1 and 2. When using a TF/TH, you must also set P-47 to "Pct-th".
4	Enable + start pushbutton (NO contact)	Stop pushbutton (NC contact)	See comments	See comments	The setpoint and actual value sources of the PI controller must be set via P-45 Level 1 and 2.
5	Enable + start pushbutton (NO contact)	Stop pushbutton (NC contact)	0: PI controller 1: Fixed setpoint speed 1	See comments	
6	Enable + start pushbutton (NO contact)	Stop pushbutton (NC contact)	External error 0: Error 1: No error	See comments	The setpoint and actual value sources of the PI controller must be set via P-45 Level 1 and 2. When using a TF/TH, you must also set P-47 to "Pct-th".
8	0: Stop 1: Enable + start	0: Clockwise rotation 1: Counterclockwise rotation	See comments	See comments	The setpoint and actual value sources of the PI controller must be set via P-45 Level 1 and 2.
13	0: Stop 1: Enable + start	0: Fixed setpoint speed 1 1: PI controller	0: Emergency mode/fire mode 1: Normal operation	See comments	The setpoint and actual value sources of the PI controller must be set via P-45 Level 1 and 2. Fire mode/emergency mode

P-16 Analog input 1 format

Setting range:

- **0: U0 – 10 V/unipolar direction of rotation with 0 – 10 V**
- 1: b0 – 10 V/bipolar direction of rotation with 0 – 10 V
- 2: A0 – 20 mA/current input
- 3: t4 – 20 mA/current input
- 4: r4 – 20 mA/current input
- 5: t20 – 4 mA/current input
- 6: r20 – 4 mA/current input

"t.." indicates that the inverter shuts down when the signal is removed while the inverter is enabled. t4 – 20 mA, t20 – 4 mA.

"r.." indicates that the inverter moves along a ramp to P-20 when the signal is removed while the inverter is enabled. r4 – 20 mA, r20 – 4 mA.

INFORMATION



The analog input can be scaled with the parameters P-35 (→ 104) and P-39.

Example of bipolar speed with unipolar voltage source

This function allows for infinitely variable speeds over the entire speed range of -100% to +100% via P-01 without changing the digital input for the reversal of the direction of rotation.

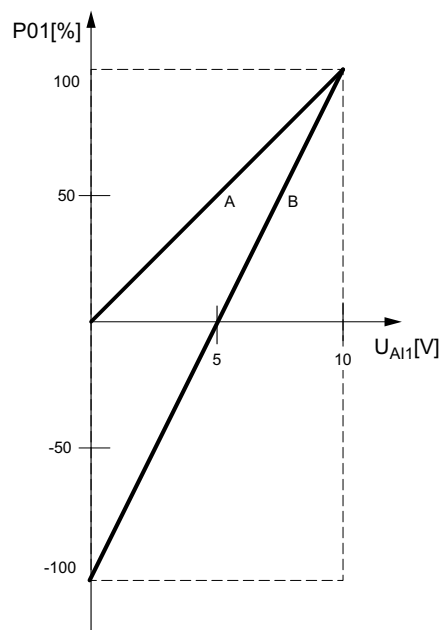

18014411314390795

Characteristic curve [A] (unipolar speed):
 Input voltage signal:
 0 – 10 V
 Setting:
 P-16 = U0 – 10 V (unipolar)
 P-35 = 100% (default)
 P-39 = 0% (default)

Characteristic curve [B] (bipolar speed):
 Input voltage signal:
 0 – 10 V
 Setting:
 P-16 = b0 – 10 V (bipolar)
 P-35 = 200%
 P-39 = 50%

P-17 PWM switching frequency

Setting range: 2 – 4 – 16 kHz (power-dependent)

Specifies the pulse width modulated switching frequency. A higher switching frequency means less motor noise, but also higher losses in the output stage. The maximum switching frequency depends on the inverter power rating.

The inverter reduces the switching frequency automatically, depending on the following conditions:

- Heat sink temperature
- Output frequency
- Overload

Heat sink temperature	Output frequency (min. and max. thresholds)	Overload Output current	Changeover behavior
70 °C	7 – 9 Hz	–	Reduction to 12 kHz
75 °C	5 – 7 Hz	–	Reduction to 8 kHz
80 °C	3 – 5 Hz	–	Reduction to 6 kHz
85 °C	1 – 3 Hz	>140%	Reduction to 4 kHz
95 °C	–	–	Overtemperature error message

P-18 User relay output function selection

Setting range: 0 – 1 – 8

The function of the relay output can be selected according to the table below.

If a relay is controlled depending on a limit value, it reacts according to the curve in P-50 (→ 108).

Set-tings	Function	Explanation
0	Inverter enabled	Relay contacts closed when inverter is enabled.
1	Frequency inverter is ready for operation	Relay contacts closed when inverter is operable (no error).
2	Motor at setpoint speed	Relay contacts closed when output frequency = setpoint frequency ± 0.1 Hz.
3	Frequency inverter in fault status	Relay contacts closed when the inverter is in fault status.
4	Motor speed \geq limit value P-19 in relation to P-01 The switching hysteresis can be set in P-50.	Relay contacts closed when output frequency is greater than the value set in parameter "Limit value for relay/analog output". Relay contacts opened when value is lower than "Limit value for relay/analog output".
5	Motor current \geq limit value P-19 in reference to P-08 The switching hysteresis can be set in P-50.	Relay contacts closed when motor current/torque is greater than the current limit set in parameter "Limit value for relay/analog output". Relay contacts opened when value is lower than "Limit value for relay/analog output".
6	Motor speed $<$ limit value P-19 in relation to P-01 The switching hysteresis can be set in P-50.	Relay contacts closed when output frequency is less than the value set in parameter "Limit value for relay/analog output". Relay contacts opened when value is greater than "Limit value for relay/analog output".
7	Motor current $<$ limit value P-19 in reference to P-08 The switching hysteresis can be set in P-50.	Relay contacts closed when motor current/torque is less than the current limit set in parameter "Limit value for relay/analog output". Relay contacts opened when value is greater than "Limit value for relay/analog output".
8	Analog input 2 $>$ limit value P-19 The switching hysteresis can be set in P-50.	Relay contacts closed when second analog input value is greater than the value set in parameter "Limit value for relay/analog output". Relay contacts opened when value is lower than "Limit value for relay/analog output".

P-19 Limit value for relay/analog output

Setting range: 0.0 – **100.0** – 200.0%
Specifies the limit values for *P-18* and *P-25*.

P-20 Fixed setpoint speed 1

Setting range: *-P-01* – **5.0 Hz** – *P-01*

P-21 Fixed setpoint speed 2

Setting range: *-P-01* – **25.0 Hz** – *P-01*

P-22 Fixed setpoint speed 3

Setting range: *-P-01* – **40.0 Hz** – *P-01*

P-23 Fixed setpoint speed 4

Setting range: *-P-01* – **P-01**

P-24 Second deceleration ramp, rapid stop ramp

Setting range: 0.00 – **2** – 25 s

Is selected automatically in the event of a power failure if *P-05* = 2.

Can also be selected using digital inputs depending on other parameter settings. Setting "0" means the motor coasts to a halt.

P-25 Analog output/digital output function selection

Setting range: 0 – 8 – 10

The function of the analog output/digital output can be selected according to the table below.

If P-25 is selected as the digital output, it behaves according to the curve in P-50.
(→  108)

Set-tings	Function	Explanation
0	Inverter enabled (digital)	Logical 1 if the inverter is enabled.
1	Frequency inverter is ready for operation (digital)	Logical 1 if the inverter is ready for operation (no error).
2	Motor at setpoint speed (digital)	Logical 1 if the output frequency = setpoint frequency ± 0.1 Hz.
3	Frequency inverter is in error status (digital)	Logical 1 if the inverter is in error status.
4	Motor speed \geq limit value P-19 in relation to P-01 (digital) The switching hysteresis can be set in P-50.	Logical 1 if the output frequency is greater than the value set in the parameter "Limit value for relay/analog output". Relay contacts opened if the value is lower than the "Limit value for relay/analog output".
5	Motor current \geq limit value P-19 in relation to P-08 (digital) The switching hysteresis can be set in P-50.	Logical 1 if the motor current/torque is greater than the current limit value set in the parameter "Limit value for relay/analog output". Relay contacts opened if the value is lower than the "Limit value for relay/analog output".
6	Motor speed $<$ limit value P-19 in relation to P-01 (digital) The switching hysteresis can be set in P-50.	Logical 1 if the output frequency is lower than the value set in the parameter "Limit value for relay/analog output". Relay contacts opened if the value is greater than the "Limit value for relay/analog output".
7	Motor current $<$ limit value P-19 in relation to P-08 (digital) The switching hysteresis can be set in P-50.	Logical 1 if the motor current/torque is lower than the current limit value set in the parameter "Limit value for relay/analog output". Relay contacts opened if the value is greater than the "Limit value for relay/analog output".
8	Motor speed (analog)	The amplitude of the analog output signal represents the motor speed. It is scaled from 0 to the maximum speed limit defined in P-01.
9	Motor current (analog)	The amplitude of the analog output signal represents the inverter output current (torque). It is scaled from 0 to 200% of the rated motor current defined in P-08.
10	Motor power (analog)	The amplitude of the analog output signal represents the apparent output power of the inverter. It is scaled from 0 to 200% of the inverter nominal power.

P-26/P-27 Skip frequency band/skip frequency

P-26 setting range: **0 Hz** – P-01

P-27 setting range: **P-02** – P-01

In some applications, mechanical resonance vibrations may occur in certain speed ranges. This may have a negative effect on the machine behavior. The speed skip function can be used to skip the interfering speed range. The drive speed performs the depicted hysteresis with the ramps specified in P-03 and P-04.

If the setpoint speed is within the skipped frequency range, the actual speed remains on the upper or lower limit of the frequency range, depending on the previous setpoint.

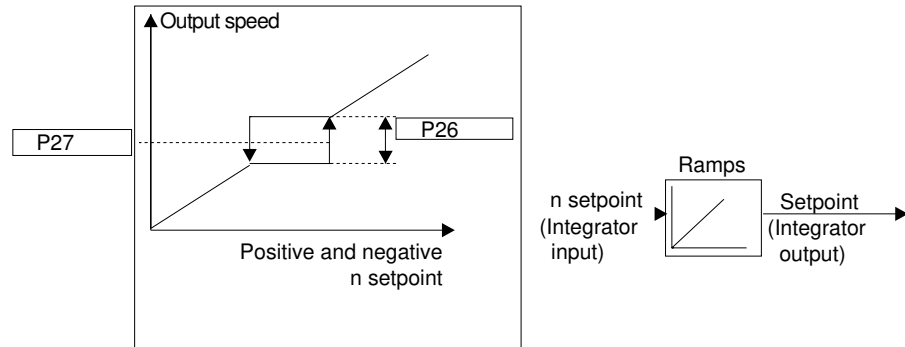

20197631243

P-28/P-29 V/f characteristic curve adjustment

Setting range *P-28*: 0 – *P-07* in Volt

Setting range *P-29*: 0 – *P-09* in Hertz

The voltage/frequency characteristic curve determines the voltage level applied to the motor at a given frequency. Parameters *P-29* and *P-28* let you change the V/f characteristic curve if required.

Parameter *P-29* can be set to any frequency between 0 and the base frequency (*P-09*). It represents the frequency at which the percentage adjustment level set in *P-28* is used. This function is only active when *P-51* = 1.

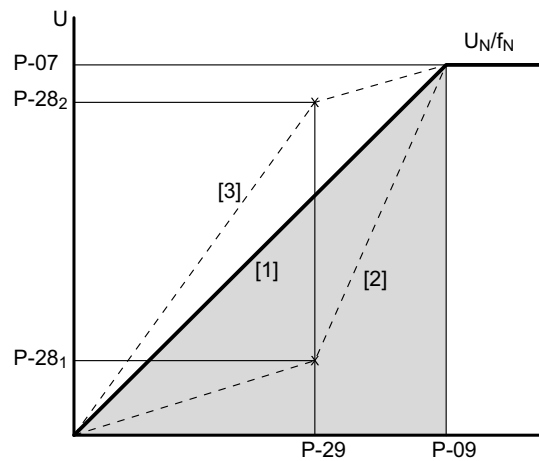

9007211519924363

- [1] Normal V/f characteristic curve
- [2] Adjusted V/f characteristic curve (example 1)
- [3] Adjusted V/f characteristic curve (example 2)

P-07 = Rated motor voltage

P-09 = Rated motor frequency

P-28 = Voltage value of adjustment of the V/f characteristic curve

P-29 = Frequency value of adjustment of the V/f characteristic curve

P-30 Start mode selection

The selection of the start mode defines the inverter behavior with reference to the enable digital input and also configures the automatic restart function.

Setting range: Edge-r – **Auto-0** – Auto-5

Edge-r

- Edge-r: After activation or resetting of an error, the frequency inverter does not start automatically, even if an enable signal is still present at the relevant digital input. To start the frequency inverter after activation or resetting, the signal must first be deleted (open switch) and then reset (close switch).

Auto-0:



▲ WARNING

With the setting "Auto-0" and set enable signal, there is a danger of an automatic restart of the drive after an error message has been acknowledged (reset) or after switch-on (voltage on).

Fatal or severe injuries and damage to property.

- Disconnect the device from the power supply before rectifying an error if automatic restart of the driven machine after error elimination is not permitted for safety reasons.
- After a reset, make sure that the drive can start up automatically depending on the setting.
- Prevent the system from performing an unintentional startup.

- After activation or resetting, the frequency inverter starts automatically if an enable signal is present at the relevant digital input.

Auto-1 – Auto-5



▲ WARNING

With the setting "Auto-1 – Auto-5" and set enable signal, there is a danger of an automatic restart of the drive after fault elimination or after switch-on (voltage on) as the inverter tries 1 – 5 times to automatically acknowledge the error.

Fatal or severe injuries and damage to property.

- Disconnect the device from the power supply before rectifying an error if automatic restart of the driven machine after error elimination is not permitted for safety reasons.
- After a reset, make sure that the drive can start up automatically depending on the setting.
- Prevent the system from performing an unintentional startup.

- Following an error shutdown (trip), the frequency inverter makes up to 5 attempts to restart at intervals of 20 seconds. To reset the counter, the frequency inverter must be de-energized. The number of attempted restarts is counted. If the frequency inverter is unable to start the drive with the final attempt, a permanent error shutdown occurs, which can only be reset by pressing the "Reset" key.

P-31 Enable behavior/changeover behavior for keypad/fieldbus

Keypad:

Defines the changeover and enable behavior of the frequency inverter when controlled via the integrated operator terminal.

The selection depends on the setting in *P-15*.

Setting range: 0 – 1 – 7

Changeover behavior when switching the setpoint source of keypad mode:	
0	The motor speed continues at the minimum speed set in <i>P-02</i> .
1	The motor speed changes to the previously set keypad speed.
2	The motor speed continues at the minimum speed set in <i>P-02</i> .
3	The motor speed changes to the previously set keypad speed.
4	The current motor speed is applied during changeover.
5	The motor speed continues at the fixed setpoint speed set in <i>P-23</i> .
6	The current motor speed is applied during changeover.
7	The motor speed continues at the fixed setpoint speed set in <i>P-23</i> .

Enable behavior when the inverter is enabled in keypad mode:	
0	The motor starts up at the minimum speed set in <i>P-02</i> .
1	The motor starts up at the previously set keypad speed.
2	The motor starts up at the minimum speed set in <i>P-02</i> .
3	The motor starts up at the previously set keypad speed.
4	The motor starts up at the minimum speed set in <i>P-02</i> .
5	The motor starts up at the fixed setpoint speed set in <i>P-23</i> .
6	The motor starts up at the minimum speed set in <i>P-02</i> .
7	The motor starts up at the fixed setpoint speed set in <i>P-23</i> .

In the setting 2, 3, 6, or 7, the inverter is started with the corresponding enable digital input.

The <Start> and <Stop> keys on the keypad are out of function.

You can modify the speed with the <Up> and <Down> keys.

Fieldbus:

Applies both when changing over the setpoint source and also when enabling the inverter.

In the setting 0, 1, 4, or 5, the inverter is started with the fieldbus enable and an additional hardware enable. The speed setpoint is transferred from the fieldbus.

In the setting 2, 3, 6, or 7, the inverter is started only with the hardware enable. The fieldbus enable is not necessary. The speed setpoint is transferred from the fieldbus.

P-32 DC hold function

The parameter is divided into two levels and only works in combination with settings in P-58 and P-59.

Level 1: Current holding time

Setting range: **0.0** – 25 s

The set value determines the duration of the direct current holding function.

Level 2: Current holding mode

Setting range: **0** – 2

The set value determines the function of the direct current holding function.

- 0: Direct current injection at STOP
- 1: Direct current injection at START
- 2: Direct current injection at START and STOP

P-33 Enable flying start function

Setting range: **0** – 2

When the flying start function is enabled, the frequency inverter first determines the current rotor speed. This causes a minor delay between the enable and the startup. This function protects the inverter from overcurrent errors when connecting to rotating motors.

The flying start function is possible only in the operating modes V/f and LVFC.

- 0: Flying start function disabled
- 1: Flying start function enabled
- 2: Flying start function enabled if the following conditions are met:
 - Switch off with error
 - Voltage drop
 - Stop mode, coasting to a stop

P-34 Brake chopper activation

Setting range: **0** – 2

- 0: Deactivated
- 1: Activated with software protection for the braking resistor type BW LT 100 002. An error message is issued when the maximum power is exceeded.
- 2: Activated for all other braking resistors without software protection. The braking resistor must be protected externally.

P-35 Analog input 1/slave scaling

Setting range: See 0.0 – **100.0** – 2000%

Slave scaling (P-12 = 11)

$$P-35 = (n_{\text{Slave}}/n_{\text{Master}}) \times 100\%$$

Scaling analog input (P-12 ≠ 11)

The analog input can be scaled using the parameter P-35/P-39. The scaling describes the slope of the straight sections. You can calculate the parameters with the following formulae, depending on the desired characteristic curve:

Calculation of the scaling parameters:

P-01 = Amount of the larger value of n_1 and n_2

$$P-02 = 0$$

$$P-16 = U_0 - 10 \text{ V, when } n_1 \geq 0$$

$$P-16 = b_0 - 10 \text{ V, when } n_1 < 0$$

$$P-35 = 10000 * \frac{(n_2 - n_1)}{n_2(AI_2 - AI_1)}$$

$$P-39 = AI_1 - \frac{n_1(AI_2 - AI_1)}{(n_2 - n_1)}$$

with:

$$[AI_1]; [AI_2] = \%$$

$$100\% \triangleq AI_{\text{max}} (10 \text{ V or } 20 \text{ mA})$$

$$[n_1]; [n_2] = \text{min}^{-1} \text{ or Hz}$$

Example with calculation in Hz (P-10 = 0)

$$P-01 = 50 \text{ Hz, as } |n_2| > |n_1|$$

$$P-02 = 0 \text{ Hz}$$

$$P-16 = b_0 - 10 \text{ V, as } n_1 < 0$$

$$P-35 = 10000 * \frac{(50 - (-50))}{50(80 - 0)} = 250 \%$$

$$P-39 = 0 - \frac{-50(80 - 0)}{(50 - (-50))} = 40 \%$$

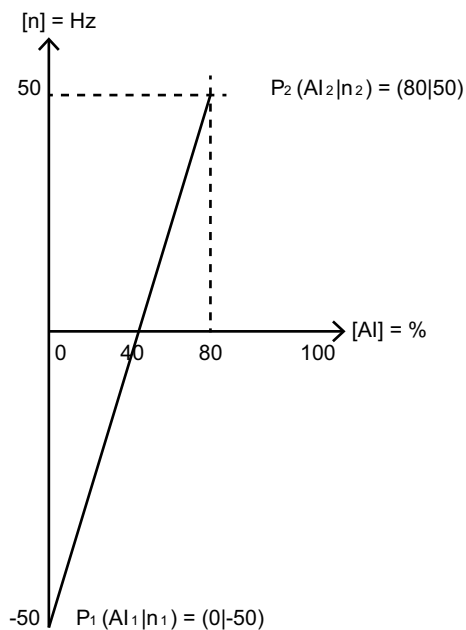

9007221967494923

P-36 Fieldbus settings

The parameter is divided into three levels and depends on the setting specified in P-12.

Level 1: Inverter address

Setting range: 1 – 63

Defines the general inverter address for SBus, Modbus, fieldbus, and master/slave.

Level 2: Baud rate

Setting range: 0 – 1 – 5

Defines the baud rate, depending on the bus system.

Selection	SBus (P-12 = 3/4) CAN (P-12 = 5/6)	Modbus RTU (P-12 = 7/8)
0	500 kb/s	9.6 kb/s
1	500 kb/s	115.2 kb/s
2	125 kb/s	19.2 kb/s
3	250 kb/s	38.4 kb/s
4	500 kb/s	57.6 kb/s
5	1 Mb/s	76.8 kb/s

Level 3: Timeout behavior

Setting range: 0 – 8

Defines the time in seconds after which the inverter performs the set response in the event of a communication failure.

- 0: The last setpoint is retained. There is no switch off with error.
- 1: t30 ms
- 2: t100 ms
- 3: t1000 ms
- 4: t3000 ms
- 5: r30 ms
- 6: r100 ms
- 7: r1000 ms
- 8: r3000 ms

t_x: The frequency inverter switches off immediately and the motor coasts to a halt as soon as the time has elapsed.

r_x: The motor stops along the rapid stop ramp P-24 as soon as the time has elapsed.

P-37 Extended parameter access code definition

Setting range: 0 – **101** – 9999

The set value determines the code for the full parameter access in *P-14*.

P-38 Parameter lock

Locking parameters means that no parameters can be changed (indicated by "L").

- **0: Deactivated**
- 1: Activated

P-39 Analog input 1 offset

Setting range: -500 – **0.0** – 500%

The offset describes the percentage offset of the analog input signal on the characteristic curve in X-direction.

For a calculation example, see *P-35* (→ 104).

P-40 Actual speed value scaling factor

The parameter is divided into two levels. The value is shown in the display in real time as follows (c XXXX).

See also PI controller mode (→ 52)

Level 1: Scaling factor

Setting range: **0000** – 16 000

Level 2: Display scaling source

Setting range: **0** – 2

- 0: Motor speed information is used as the scaling source.
- 1: Motor current information is used as the scaling source.
- 2: The value of the second analog input is used as the scaling source. In this case, the range of input values is 0 to 4096.

P-41 Thermal motor protection according to UL508C

- 0: Disabled
- **1: Activated**

The frequency inverters come equipped with a thermal motor protection function according to NEC (National Electrical Code) to protect the motor from overload. The motor current is accumulated over time in an internal store.

The frequency inverter goes to error state as soon as the thermal limit is exceeded (I.t-trP).

Once the output current of the inverter is less than the set rated motor current, the internal store is decremented depending on the output current.

When *P-41* is disabled, the thermal overload store is reset by switching the power off and on again.

When *P-41* is enabled, the store is maintained even after the power is switched off and on again.

P-42 PI proportional gain

Setting range: 0.0 – **1.0** – 30.0

PI controller proportional gain. Higher values result in a greater change of the inverter output frequency as response to minor changes of the feedback signal. If the value is too high, it can cause instability.

P-43 PI integral time constant

Setting range: 0.0 – **1.0** – 30.0 s

PI controller integral time constant. Higher values result in a damped response to systems in which the overall process responds slowly.

P-44 PI operating mode

- **0: Direct operation** – The motor speed decreases with increasing feedback signal.
- **1: Inverse operation** – The motor speed increases with increasing feedback signal.

P-45 PI reference selection

The parameter is divided into two levels.

Level 1: PI reference source

Setting range: **0** – 1

- **0: P-46 PI fixed setpoint reference**
- **1: Analog input 1**

Level 2: PI feedback source

Setting range: **0** – 5

- **0: Analog input 2**
- **1: Analog input 1**
- **2: Motor current**
- **3: DC link voltage $U_{DC\ link}$**
- **4: Difference (AI1 – AI2)**
- **5: Maximal value (AI1 or AI2)**

P-46 PI fixed setpoint reference

Setting range: **0.0** – 100.0%

Sets the preset digital PI reference/setpoint.

P-47 Analog input 2 format

Setting range:

- **0: U0 – 10 V/unipolar voltage input**
- 1: A0 – 20 mA/current input
- 2: t4 – 20 mA/current input
- 3: r4 – 20 mA/current input
- 4: t20 – 4 mA/current input
- 5: r20 – 4 mA/current input
- 6: Ptc-th/motor thermistor input

"t.." indicates that the inverter shuts down when the signal is removed while the inverter is enabled. t4 – 20 mA, t20 – 4 mA.

"r.." indicates that the inverter moves along a ramp to *P-20* when the signal is removed while the inverter is enabled. R4 – 20 mA, r20 – 4 mA.

P-48 Standby mode

Setting range: **0.0** – 25 s

When *P-48* > 0, the inverter goes to standby mode if the minimum speed is maintained for the time specified in *P-48*.

P-49 PI control difference wake-up level

Setting range: 0.0 – **5.0** – 100%

Sets a programmable level. When the drive is in standby or PI mode, the selected feedback signal must fall below this threshold before the inverter returns to normal operation.

P-50 Hysteresis band user relay

Setting range: **0.0** – 100%

This parameter can be used to adjust the switching hysteresis to prevent undesirable unstable relay statuses.

The percentage setting range refers to the selection in *P-18* and *P-25*.

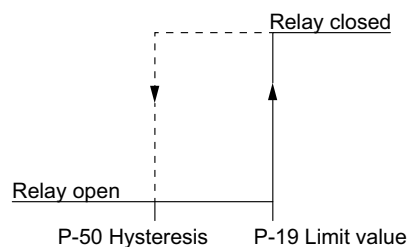

18014411224512267

P-51 Operating mode/motor control

Setting range: 0 – 1 – 5

- 0: LVFC speed control (Light Vector Flux Control)

Vector speed control for induction motors with calculated rotor speed control. Field-oriented control algorithms are used for motor speed control. As the calculated rotor speed is used to internally close the speed loop, this control mode effectively provides a simple closed loop system without a physical encoder. For optimal control, "Auto tune" (P-52) should be carried out prior to first operation.

- **1: Extended V/f speed control (asynchronous motors)**

In the operating mode V/f control, the output voltage and the frequency are controlled proportionally in an equal ratio. Almost all asynchronous motors can be controlled in this way. If a better performance is required with regard to control mode, torque stability, and speed range, the LVFC control mode should be used.

- Slip compensation

If P-10 \neq 0 is set, the calculated slip speed is added to the output frequency.

If P-10 = 0 is set, the slip is not included in the calculation. As a result, the motor controller reacts very softly to any change of load and does not tend to oscillate. SEW-EURODRIVE recommends using this motor controller in fans, pumps, and applications with direct drive.

- 2: Synchronous motor speed control (PMVC)

Speed control for synchronous motors. This control has the same characteristics as the LVFC speed control.

- 3: Brushless DC motor speed control (BLDC)

Speed control for brushless DC motors

- 4: Synchronous reluctance motor speed control (SYN-R)

Speed control for synchronous reluctance motors

- 5: LSPM speed control (Line Start Permanent Magnet motors)

The LSPM speed control is designed for asynchronous motors with synchronous characteristics such as motors of type DR../ with LSPM technology from SEW-EURODRIVE.

P-52 Auto tune

- **0: Inhibited**
- 1: Enable

Only enable the inverter after you have entered all nominal motor data correctly in the parameters. You can also start the automatic measuring procedure "Auto tune" manually with this parameter after entering the motor data.

The measurement process lasts up to 2 minutes depending on the control mode.

INFORMATION

After changing the nominal motor data, auto tune has to be started again.



P-53 Controller parameter

The parameter is divided into two levels.

Level 1: Speed controller proportional gain

Setting range: 0 – 250%

Defines the proportional gain for the speed controller. Higher values provide for better output frequency regulation and response. If the value is too high, it can cause instability or even overcurrent errors. For applications that require the best possible control, you can adapt the value to the connected load by gradually increasing the value and observing the actual speed of the load. Continue this process until you have achieved the required dynamics without or with only slightly exceeding the control range, i.e. the setpoint value of the output speed.

In general, higher friction loads can tolerate higher values of proportional gain. It might be necessary to reduce the gain for loads with high inertia and low friction.

Level 2: Speed controller integrating time constant

Setting range: 0.00 – 2.50 s

Defines the integral time for the speed controller. Small values result in a faster response to changes in the motor load but bear the risk that they cause instability. For optimal dynamics, the value must be adjusted to match the connected load.

P-54 Current limit

Setting range: 0.1 – **150** – 175 %

The set value relates to the nominal motor current *P-08* and defines the maximum current limit of the inverter.

P-55 – P57



NOTICE

Possible damage to the frequency inverter in the case of incorrect settings of the internal parameters.

Damage to property.

- To allow the most effective possible motor control, the following parameters are used internally by the inverter. Incorrect settings of the parameters can impair the performance and cause unexpected behavior of the motor.
- Adjustments may be made only by experienced users who fully understand the functions of these parameters.

Equivalent wiring diagram for AC motors.

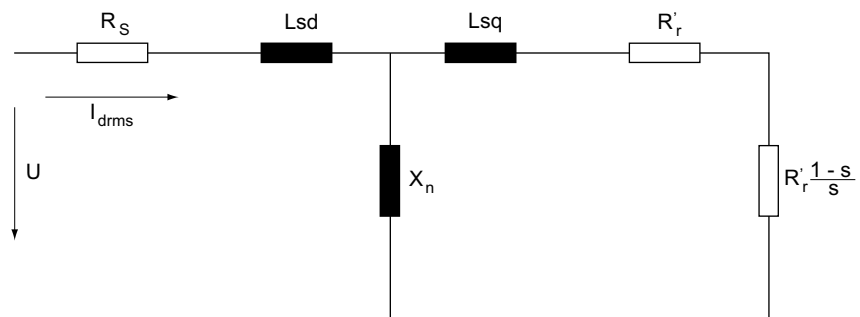

7372489995

P-55 Motor stator resistance (Rs)

Setting range: depends on the motor (Ω)

The stator resistance value is the ohmic phase-phase resistance of the copper winding. This value can be determined and set automatically during "auto tune".

Instead, you can enter this value manually.

P-56 Motor stator inductance (Lsd)

Setting range: depends on the motor (H)

For induction motors: Phase stator inductance value.

For synchronous motors: Phase d-axis stator inductance.

P-57 Motor stator inductance (Lsq) – only for synchronous motors

Setting range: depends on the motor (H)

For synchronous motors: Phase q-axis stator inductance.

P-58 DC braking speed

Setting range: **0.0** – P-01

This parameter defines the limit speed starting at which DC braking becomes active.

This parameter only acts together with *P-32* (level 1 and 2) and *P-59*.

P-59 Current strength of DC holding function

Setting range: 0 – **20.0** – 100%

This parameter determines the percentage current strength depending on *P-08*.

P-60 Fire mode/emergency mode speed

Setting range: -*P-01* – **0** – *P-01* Hz

The speed used in fire mode/emergency mode.

To use the function, set *P-15* to 13.

8.2.3 Configuration parameters**P-00 Configuration parameters for IP66/NEMA-4X devices with switch option**

Setting range: **SEt-1** – SEt-8

The functionality of the switch and the potentiometer can be assigned as follows.

IP66/NEMA-4X housing with switch			
Setting	Potentiometer	Switch setting CW	Switch setting CCW
SEt-1	Activated	Activated	Activated
SEt-2	Activated	Activated	Deactivated
SEt-3	Activated	Deactivated	Activated
SEt-4	Activated	Deactivated	Deactivated
SEt-5	Deactivated	Activated	Activated
SEt-6	Deactivated	Activated	Deactivated
SEt-7	Deactivated	Deactivated	Activated
SEt-8	Deactivated	Deactivated	Deactivated





Procedure:

1. Stop the inverter. The display must show "STOP". No error messages may be present.
2. Set the password in *P-14* (*Advanced parameter access*) (default = 101).
3. Press the "Up" or "Down" key until *P-00* appears in the display.
4. Press the "Stop" key for at least 1 second until SEt-x appears.
5. Press the "Up" or "Down" key to set the required function.
6. Press the "Stop" key again to save the selection and to exit the menu.

9 Technical data

9.1 Marks

The MOVTRAC® LTE-B+ inverter complies with the following regulations and directives:

Marks	Meaning
	The CE mark states compliance with the following European directives: <ul style="list-style-type: none"> • Machinery Directive 2006/42/EC • Directive 2011/65/EU for limiting the use of certain hazardous substances in electric and electronic equipment
	The waste disposal of this product is performed in compliance with the WEEE Directive 2012/19/EU.
	The UL and cUL marks declare the award of the UL approval. cUL is equivalent to CSA approval.
	The EAC mark declares compliance with the requirements of the technical regulations of the Customs Union of Russia, Kazakhstan, and Belarus.
	The RCM mark declares compliance with the technical regulations of the Australian Communications and Media Authority ACMA.

9.2 Ambient conditions

Ambient temperature range during operation (For PWM frequency 2 kHz)	-20 °C to +50 °C (IP20/NEMA 1) -20 °C to +40 °C (IP66/NEMA 4X)
Derating depending on the ambient temperature	4%/°C to 55 °C for inverters with IP degree of protection IP20/NEMA 1
	4%/°C to 45 °C for inverters with IP degree of protection IP66/NEMA 4X
Storage temperature	-40 °C to +60 °C
Maximum installation altitude for nominal operation	1000 m
Derating above 1000 m	1%/100 m to max. 2000 m with UL
	1%/100 m to max. 4000 m without UL
Maximum relative humidity	95% (condensation not permitted)
Device designs	IP20/NEMA 1
	IP66/NEMA 4X

9.3 Output power and current carrying capacity without EMC filter

The "Horsepower" (HP) data is specified as follows.

- 200 – 240 V devices: NEC2002, table 430-150, 230 V
- 380 – 480 V devices: NEC2002, table 430-150, 460 V

9.3.1 1-phase system AC 115 V for 3-phase AC 230 V motors (voltage doubler)

MOVITRAC® LTE-B+ – EMC filter class 0 to EN 61800-3				
Power in kW		0.37	0.75	1.1
IP20/NEMA 1				
MC LTE-B..		0004-101-1-00	0008-101-1-00	0011-101-4-00
Part number		18261663	18261671	18261868
IP66/NEMA-4X housing without switch				
MC LTE-B..		0004-101-1-30	0008-101-1-30	0011-101-4-30
Part number		18277497	18277500	18277519
IP66/NEMA-4X housing with switch				
MC LTE-B..		0004-101-1-40	0008-101-1-40	0011-101-4-40
Part number		18277527	18277535	18277543
INPUT				
Nominal line voltage U_{line} in accordance with EN 50160	V	1 × AC 110 – 115 ±10%		
Line frequency f_{line}	Hz	50/60 ±5%		
Line fuse	A	10	25 (20) ¹⁾	32 (30) ¹⁾
Nominal input current	A	7.8	15.8	21.9
OUTPUT				
Recommended motor power	kW	0.37	0.75	1.1
Output voltage U_{motor}	V	3 × 20 – 250		
Output current	A	2.3	4.3	5.8
PWM frequency	kHz	2/4/6/8/12/16		
Speed range	min ⁻¹	-30 000 – 0 – 30 000		
Maximum output frequency	Hz	500		
Maximum motor cable length, shielded	m	50		100
Maximum motor cable length, unshielded		75		150
GENERAL				
Size		1		2
Nominal power loss 24 V	W	3.1		4.5
Nominal power loss, power section	W	11.1	22.5	33
Minimum braking resistance value	Ω	–		47
Maximum device terminal cross section	mm ²	2.5 (6) ²⁾		
Maximum control terminal cross section	mm ²	0.05 – 2.5		

1) Recommended values for UL compliance.

2) When used with forked cable lugs.

9.4 Output power and current carrying capacity with EMC filter

The "Horsepower" (HP) data is specified as follows.

- 200 – 240 V devices: NEC2002, table 430-150, 230 V
- 380 – 480 V devices: NEC2002, table 430-150, 460 V

9.4.1 1-phase system AC 230 V for 3-phase AC 230 V motors

MOVITRAC® LTE-B+ – EMC filter class C1 to EN 61800-3						
Power in kW	0.37	0.75	1.5		2.2	4
IP20/NEMA 1						
MC LTE-B..	0004-2B1-1-00	0008-2B1-1-00	0015-2B1-1-00	0015-2B1-4-00	0022-2B1-4-00	0040-2B1-4-00
Part number	18261728	18261752	18261787	18261892	18261930	18262139
IP66/NEMA-4X housing without switch						
MC LTE-B..	0004-2B1-1-30	0008-2B1-1-30	0015-2B1-1-30	0015-2B1-4-30	0022-2B1-4-30	0040-2B1-4-30
Part number	18276016	18276024	18276032	18276040	18276059	18276067
IP66/NEMA-4X housing with switch						
MC LTE-B..	0004-2B1-1-40	0008-2B1-1-40	0015-2B1-1-40	0015-2B1-4-40	0022-2B1-4-40	0040-2B1-4-40
Part number	18276253	18276261	18276288	18276296	18276318	18276326
INPUT						
Nominal line voltage U_{line} Complies with EN 50160	V	1 × AC 200 – 240 ±10%				
Line frequency f_{line}	Hz	50/60 ±5%				
Line fuse	A	10 (6) ¹⁾	10	16 (17.5) ¹⁾	25	40
Nominal input current	A	3.7	7.5	12.9	19.2	29.2
OUTPUT						
Recommended motor power	kW	0.37	0.75	1.5	2.2	4
Output voltage U_{motor}	V	3 × 20 – U_{line}				
Output current	A	2.3	4.3	7	10.5	16
PWM frequency	kHz	2/4/8/12/16				2/4/6/8/12
Speed range	min ⁻¹	-30 000 – 0 – 30 000				
Maximum output frequency	Hz	500				
Maximum motor cable length, shielded	m	50			100	
Maximum motor cable length, unshielded	m	75			150	
GENERAL						
Size		1		2		3
Nominal power loss 24 V	W	3.1		4.5		5.2
Nominal power loss, power section	W	11.1	22.5	45	66	120
Minimum braking resistance value	Ω	–			47	
Maximum device terminal cross section	mm ²	2.5 (6) ²⁾				2.5 (10) ²⁾
Maximum control terminal cross section	mm ²	0.05 – 2.5				

1) Recommended values for UL compliance.

2) When used with forked cable lugs.

9.4.2 3-phase system AC 230 V for 3-phase AC 230 V motors

INFORMATION



All inverters with a power supply of 3 × AC 200 – 240 V can also be operated with 1 × AC 200 – 240 V at device connections L1 and L2 when observing a derating of 50% of the output current. Application example with SWER (Single-Wire Earth Return) supply systems.

Power 1.5 – 5.5 kW

MOVITRAC® LTE-B+ – EMC filter class C2 to EN 61800-3					
Power in kW		1.5	2.2	4.0	5.5
IP20/NEMA 1					
MC LTE-B..		0015-2A3-4-00	0022-2A3-4-00	0040-2A3-4-00	0055-2A3-4-00
Part number		18261884	18261922	18262058	18267416
IP66/NEMA-4X housing without switch					
MC LTE-B..		0015-2A3-4-30	0022-2A3-4-30	0040-2A3-4-30	0055-2A3-4-30
Part number		18276075	18276083	18276091	18276105
IP66/NEMA-4X housing with switch					
MC LTE-B..		0015-2A3-4-40	0022-2A3-4-40	0040-2A3-4-40	0055-2A3-4-40
Part number		18276334	18276342	18276350	18276369
INPUT					
Nominal line voltage U_{line} in accordance with EN 50160	V	3 × AC 200 – 240 ±10%			
Line frequency f_{line}	Hz	50/60 ±5%			
Line fuse	A	16 (15) ¹⁾	16 (17.5) ¹⁾	32 (30) ¹⁾	40 (35) ¹⁾
Nominal input current	A	9.5	12.1	20.9	26.4
OUTPUT					
Recommended motor power	kW	1.5	2.2	4.0	5.5
Output voltage U_{motor}	V	3 × 20 – U_{line}			
Output current	A	7	10.5	18	24
PWM frequency	kHz	2/4/6/8/12/16		2/4/6/8/12	
Speed range	min ⁻¹	-30 000 – 0 – 30 000			
Maximum output frequency	Hz	500			
Maximum motor cable length, shielded	m	100			
Maximum motor cable length, unshielded	m	150			
GENERAL					
Size		2		3	
Nominal power loss 24 V	W	4.5		5.2	
Nominal power loss, power section	W	45	66	120	165
Minimum braking resistance value	Ω	47			22
Maximum device terminal cross section	mm ²	2.5 (6) ²⁾		2.5 (10) ²⁾	
Maximum control terminal cross section	mm ²	0.05 – 2.5			

1) Recommended values for UL compliance.

2) When used with forked cable lugs.

Power 7.5 – 18.5 kW

MOVITRAC® LTE-B+ – EMC filter class C2 to EN 61800-3					
Power in kW		7.5	11	15	18.5
		IP20/NEMA 1			
MC LTE-B..		0075-2A3-4-00	0110-2A3-4-00	0150-2A3-4-00	0185-2A3-4-00
Part number		18267424	18267432	18267440	18267459
INPUT					
Nominal line voltage U_{line} Complies with EN 50160	V	3 × AC 200 – 240 ±10%			
Line frequency f_{line}	Hz	50/60 ±5%			
Line fuse	A	40 (45) ¹⁾	63 (70) ¹⁾	80	100
Nominal input current	A	33.3	50.1	70.2	82.9
OUTPUT					
Recommended motor power	kW	7.5	11	15	18.5
Output voltage U_{motor}	V	3 × 20 – U_{line}			
Output current	A	30	46	61	72
PWM frequency	kHz	2/4/6/8/12			
Speed range	min ⁻¹	-30 000 – 0 – 30 000			
Maximum output frequency	Hz	500			
Maximum motor cable length, shielded	m	100			
Maximum motor cable length, unshielded		150			
GENERAL					
Size		4		5	
Nominal power loss 24 V	W	7.5		8.8	
Nominal power loss, power section	W	225	330	450	555
Minimum braking resistance value	Ω	22	12	6	
Maximum device terminal cross section	mm ²	16		35	
Maximum control terminal cross section	mm ²	0.05 – 2.5			

1) Recommended values for UL compliance.

9.4.3 3-phase system AC 400 V for 3-phase AC 400 V motors

INFORMATION



All inverters with a power supply of 3 × AC 380 – 480 V can also be operated with 1 × AC 380 – 480 V at device connections L1 and L2 when observing a derating of 50% of the output current. Application example with SWER (Single-Wire Earth Return) supply systems.

Power 0.75 – 4 kW

MOVITRAC® LTE-B+ – EMC filter class C2 to EN 61800-3					
Power in kW		0.75	1.5	2.2	4
IP20/NEMA 1					
MC LTE-B..		0008-5A3-1-00	0015-5A3-1-00	0015-5A3-4-00	0022-5A3-4-00
Part number		18261809	18261825	18261957	18261973
IP66/NEMA-4X housing without switch					
MC LTE-B..		0008-5A3-1-30	0015-5A3-1-30	0015-5A3-4-30	0022-5A3-4-30
Part number		18276148	18276156	18276164	18276172
IP66/NEMA-4X housing with switch					
MC LTE-B..		0008-5A3-1-40	0015-5A3-1-40	0015-5A3-4-40	0022-5A3-4-40
Part number		18276393	18276407	18276415	18276423
INPUT					
Nominal line voltage U_{line} in accordance with EN 50160	V	3 × AC 380 – 480 ±10%			
Line frequency f_{line}	Hz	50/60 ±5%			
Line fuse	A	6	10	16 (10) ¹⁾	16 (15) ¹⁾
Nominal input current	A	3.5	5.6	7.5	11.5
OUTPUT					
Recommended motor power	kW	0.75	1.5	2.2	4
Output voltage U_{motor}	V	3 × 20 – U_{line}			
Output current	A	2.2	4.1	5.8	9.5
PWM frequency	kHz	2/4/6/8/12/16			
Speed range	min ⁻¹	-30 000 – 0 – 30 000			
Maximum output fre- quency	Hz	500			
Maximum motor cable length, shielded	m	50		100	
Maximum motor cable length, unshielded	m	75		150	
GENERAL					
Size		1		2	
Nominal power loss 24 V	W	4.6		6.4	
Nominal power loss, power section	W	22	45	66	120
Minimum braking resis- tance value	Ω	–		100	
Maximum device termi- nal cross section	mm ²	2.5 (6) ²⁾			
Maximum control termi- nal cross section	mm ²	0.05 – 2.5			

1) Recommended values for UL compliance.

2) When used with forked cable lugs.

Power 5.5 – 11 kW

MOVITRAC® LTE-B+ – EMC filter class C2 to EN 61800-3				
Power in kW		5.5	7.5	11
IP20/NEMA 1				
MC LTE-B..		0055-5A3-4-00	0075-5A3-4-00	0110-5A3-4-00
Part number		18262074	18262090	18262112
IP66/NEMA-4X housing without switch				
MC LTE-B..		0055-5A3-4-30	0075-5A3-4-30	0110-5A3-4-30
Part number		18276199	18276202	18276210
IP66/NEMA-4X housing with switch				
MC LTE-B..		0055-5A3-4-40	0075-5A3-4-40	0110-5A3-4-40
Part number		18276458	18276466	18276474
INPUT				
Nominal line voltage U_{line} in accordance with EN 50160	V	3 × AC 380 – 480 ±10%		
Line frequency f_{line}	Hz	50/60 ±5%		
Line fuse	A	25	32 (30) ¹⁾	40 (35) ¹⁾
Nominal input current	A	17.2	21.2	27.5
OUTPUT				
Recommended motor power	kW	5.5	7.5	11
Output voltage U_{motor}	V	3 × 20 – U_{line}		
Output current	A	14	18	24
PWM frequency	kHz	2/4/6/8/12		
Speed range	min ⁻¹	-30 000 – 0 – 30 000		
Maximum output frequency	Hz	500		
Maximum motor cable length, shielded	m	100		
Maximum motor cable length, unshielded		150		
GENERAL				
Size		3		
Nominal power loss 24 V	W	6.4		
Nominal power loss, power section	W	165	225	330
Minimum braking resistance value	Ω	47		
Maximum device terminal cross section	mm ²	2.5 (10) ²⁾		
Maximum control terminal cross section	mm ²	0.05 – 2.5		

1) Recommended values for UL compliance.

2) When used with forked cable lugs.

Power 15 – 22 kW

MOVITRAC® LTE-B+ – EMC filter class C2 to EN 61800-3				
Power in kW		15	18.5	22
		IP20/NEMA 1		
MC LTE-B..		0150-5A3-4-00	0185-5A3-4-00	0220-5A3-4-00
Part number		18262147	18262155	18262163
INPUT				
Nominal line voltage U_{line} in accordance with EN 50160	V	3 × AC 380 – 480 ± 10%		
Line frequency f_{line}	Hz	50/60 ± 5%		
Line fuse	A	40 (45) ¹⁾	50 (60) ¹⁾	63 (70) ¹⁾
Nominal input current	A	34.2	44.1	51.9
OUTPUT				
Recommended motor power	kW	15	18.5	22
Output voltage U_{motor}	V	3 × 20 – U_{line}		
Output current	A	30	39	46
PWM frequency	kHz	2/4/6/8/12		
Speed range	min ⁻¹	-30 000 – 0 – 30 000		
Maximum output frequency	Hz	500		
Maximum motor cable length, shielded	m	100		
Maximum motor cable length, unshielded		150		
GENERAL				
Size		4		
Nominal power loss 24 V	W	14.6		
Nominal power loss, power section	W	450	555	660
Minimum braking resistance value	Ω	39		
Maximum device terminal cross section	mm ²	16		
Maximum control terminal cross section	mm ²	0.05		

1) Recommended values for UL compliance.

Power 30 – 37 kW

MOVITRAC® LTE-B+ – EMC filter class C2 to EN 61800-3			
Power in kW		30	37
		IP20/NEMA 1	
MC LTE-B..		0300-5A3-4-00	0370-5A3-4-00
Part number		18267394	18267408
INPUT			
Nominal line voltage U_{line} in accordance with EN 50160	V	3 × AC 380 – 480 ± 10%	
Line frequency f_{line}	Hz	50/60 ±5%	
Line fuse	A	80	100
Nominal input current	A	63.8	76.4
OUTPUT			
Recommended motor power	kW	30	37
Output voltage U_{motor}	V	3 × 20 – U_{line}	
Output current	A	61	72
PWM frequency	kHz	2/4/6/8/12	
Speed range	min ⁻¹	-30 000 – 0 – 30 000	
Maximum output frequency	Hz	500	
Maximum motor cable length, shielded	m	100	
Maximum motor cable length, unshielded		150	
GENERAL			
Size		5	
Nominal power loss 24 V	W	18.6	
Nominal power loss, power section	W	900	1110
Minimum braking resistance value	Ω	12	
Maximum device terminal cross section	mm ²	35	
Maximum control terminal cross section	mm ²	0.05 – 2.5	

9.5 Input voltage ranges

Depending on the model and the nominal power, the frequency inverters are designed for direct connection to the following voltage sources:

MOVITRAC® LTE-B+		
Nominal voltage	Connection type	Rated frequency
110 – 115 V ± 10%	1-phase	50 – 60 Hz ± 5%
200 – 240 V ± 10%	1-phase	
200 – 240 V ± 10%	3-phase	
380 – 480 V ± 10%	3-phase	

Units that are connected to a 3-phase supply system are designed for a maximum power grid imbalance of 3% between the phases. For supply systems with a power grid imbalance of more than 3% (for example, in India and parts of the Asia-Pacific region including China), SEW-EURODRIVE recommends that you use input chokes.

INFORMATION



Single-phase frequency inverters can also be connected to 2 phases of a three-phase power supply system of 200 – 240 V.

Taking into account 50% derating of the nominal output current, all 3-phase inverters can also be operated as 1-phase.

9.6 Speed setting range

Operating mode/motor control (P-51)	Continuous setting range in relation to $n_{max} = 3000 \text{ min}^{-1}$	Stationary control accuracy in relation to $n_{max} = 3000 \text{ min}^{-1}$
0: LVFC speed control	1:20	±0.5%
1: V/f speed control	1:10	
2: Synchronous motor speed control (PMVC)	1:10	
3: Brushless DC motor speed control (BLDC)	1:10	
4: Synchronous reluctance motor speed control (SYN-R)	1:10	
5: LSPM speed control	1:10	

9.7 Overload capacity

The inverter supplies a constant output current of 100%.

All MOVITRAC® LTE-B+ inverter types have the following overload capacity:

- 150% for 60 seconds
- 175% for 2 seconds

With an output frequency of < 10 Hz, the overload capacity is reduced to 150% for 7.5 seconds.

9.8 Protection function

- Output short circuit, phase-phase, phase-ground
- Output overcurrent
- Overload protection
 - Inverter responds to overload as described in chapter "Overload capacity" (→ 123).
- Overvoltage error
 - Set to 123% of the maximum nominal line voltage of the inverter.
- Undervoltage error
- Overtemperature error
- Undertemperature error
 - The inverter is shut down at a temperature of under -20 °C.
- Line phase failure
 - A running inverter shuts down when one phase of a three-phase system fails for longer than 15 seconds.
- Thermal motor overload protection in accordance with NEC (National Electrical Code, US), UL508C
- Evaluation of TF, TH

9.9 Housing variants and dimensions

9.9.1 Housing variants

MOVITRAC® LTE-B+ is available with the following housing variants:

- IP20/NEMA-1 housing for installation in control cabinets
- IP66/NEMA-4X housing without switch option
- IP66/NEMA-4X housing with switch option

The IP66/NEMA-4X housing is protected against moisture and dust. These frequency inverters can be operated indoors in a dusty or damp environment.

The device variant IP66/NEMA-4X housing with switch options is fitted with a main switch, a direction of rotation switch, and a potentiometer.

9.9.2 Dimensions IP20/NEMA-1 housing

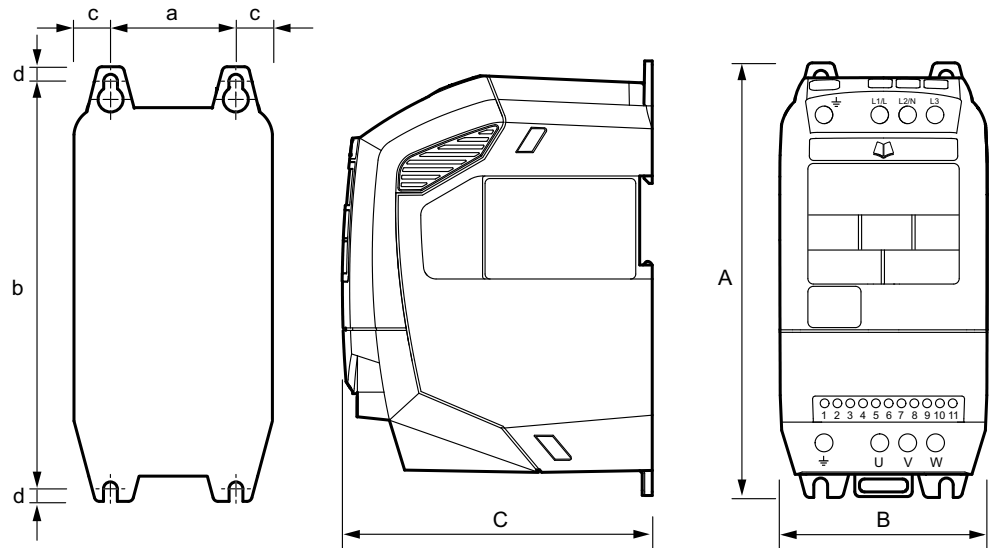

9007204991655691

Dimensions	Unit	Size 1	Size 2	Size 3	Size 4	Size 5
Height (A)	mm	173	221	261	420	486
Width (B)	mm	83	110	131	171	222
Depth (C)	mm	123	150	175	212	226
Mass	kg	1.0	1.7	3.2	9.1	18.1
a	mm	50	63	80	125	175
b	mm	162	209	247	400	463
c	mm	16.5	23.5	25.5	23	24
d	mm	6	6	7	10	11.5
Recommended screws		4 × M4	4 × M4	4 × M4	4 × M8	4 × M8

9.9.3 Dimensions of IP66/NEMA-4X housings (LTE xxx -30 and -40)

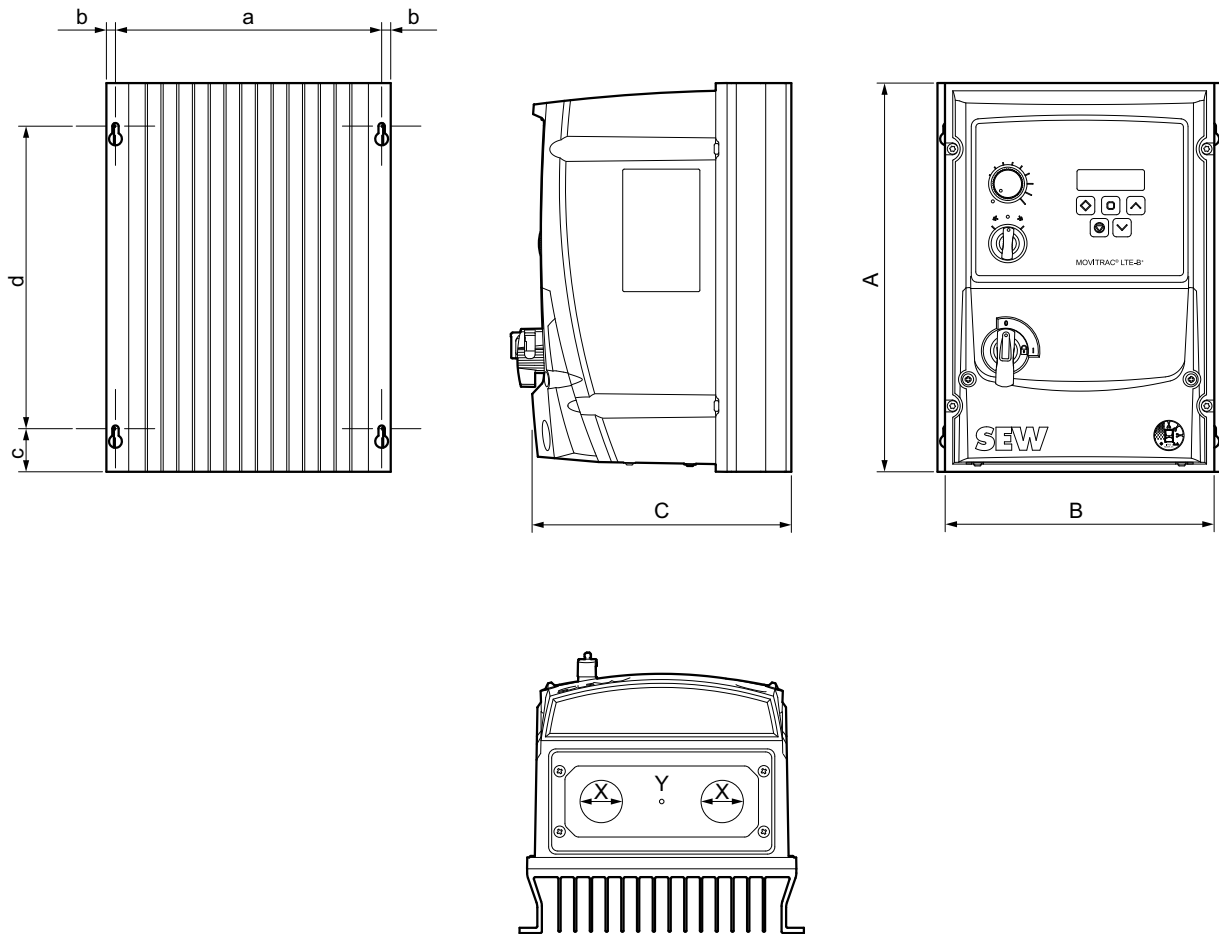

30819615755

Dimensions		Size 1	Size 2	Size 3
Height (A)	mm	232	257	310
Width (B)	mm	161	188	211
Depth (C)	mm	162	182	238
Mass	kg	2.5	3.5	7
a	mm	148.5	176	197.5
b	mm	8	8.5	8.5
c	mm	25	28.5	33.4
d	mm	189	200	251.5
Recommended screw size		4 × M4	4 × M4	4 × M4
X ¹⁾	mm	22	29	29
	PG/M ²⁾	PG13.5/M20	PG21/M25	PG21/M25
Y ³⁾	mm	22	22	22
	PG/M ²⁾	PG13.5/M20	PG13.5/M20	PG13.5/M20

- 1) The cable bushing X is open ex factory.
- 2) The specified data refers to plastic screws.
- 3) The cable bushing Y is prepunched and can be drilled out with a suitable tool.

29135451/EN – 01/2020

10 Service

To ensure fault-free operation, SEW-EURODRIVE recommends that you check the ventilation openings in the housing at regular intervals and clean them if necessary.

10.1 Electronics Service by SEW-EURODRIVE

If you are unable to rectify a fault, contact SEW-EURODRIVE Service. For the addresses, refer to www.sew-eurodrive.com.

When contacting SEW-EURODRIVE Service, always specify the following information so that our service personnel can assist you more effectively:

- Information on the device type on the nameplate (e.g. type designation, serial number, part number, product key, purchase order number)
- Brief description of the application
- Fault message on the status display
- Nature of the fault
- Accompanying circumstances
- Any unusual events preceding the problem

10.2 Extended storage

If the unit is stored for a long time, connect it to the supply system voltage for at least 5 minutes every 2 years. Otherwise, the unit's service life may be reduced.

Procedure when maintenance has been neglected:

Electrolytic capacitors are used in the inverters. They are subject to aging effects when de-energized. This effect can damage the capacitors if the unit is connected using the nominal voltage after a longer period of storage.

If you have not performed maintenance regularly, SEW-EURODRIVE recommends that you increase the line voltage slowly up to the maximum voltage. This can be done, for example, by using a variable transformer for which the output voltage has been set according to the following overview.

The following stages are recommended:

AC 115 V devices:

- Stage 1: AC 80 V for 15 minutes
- Stage 2: AC 115 V for 1 hour

AC 230 V devices:

- Stage 1: AC 170 V for 15 minutes
- Stage 2: AC 200 V for 15 minutes
- Stage 3: AC 240 V for 1 hour

AC 400 V devices:

- Stage 1: AC 0 V to AC 350 V within a few seconds
- Stage 2: AC 350 V for 15 minutes
- Stage 3: AC 420 V for 15 minutes
- Stage 4: AC 480 V for 1 hour

After you have completed the regeneration process, the device can be used immediately or stored again for an extended period with maintenance.

10.3 Waste disposal

Dispose of the product and all parts separately in accordance with their material structure and the national regulations. Put the product through a recycling process or contact a specialist waste disposal company. If possible, divide the product into the following categories:

- Iron, steel or cast iron
- Stainless steel
- Magnets
- Aluminum
- Copper
- Electronic parts
- Plastics

The following materials are hazardous to health and the environment. These materials must be collected and disposed of separately.

- Oil and grease

Collect used oil and grease separately according to type. Ensure that the used oil is not mixed with solvent. Dispose of used oil and grease correctly.

- Screens
- Capacitors



Waste disposal according to WEEE Directive 2012/19/EU

This product and its accessories may fall within the scope of the country-specific application of the WEEE Directive. Dispose of the product and its accessories according to the national regulations of your country.

For further information, contact the responsible SEW-EURODRIVE branch or an authorized partner of SEW-EURODRIVE.

11 Address list

Argentina			
Assembly Sales	Buenos Aires	SEW EURODRIVE ARGENTINA S.A. Ruta Panamericana Km 37.5, Lote 35 (B1619IEA) Centro Industrial Garín Prov. de Buenos Aires	Tel. +54 3327 4572-84 Fax +54 3327 4572-21 http://www.sew-eurodrive.com.ar sewar@sew-eurodrive.com.ar
Australia			
Assembly Sales Service	Melbourne	SEW-EURODRIVE PTY. LTD. 27 Beverage Drive Tullamarine, Victoria 3043	Tel. +61 3 9933-1000 Fax +61 3 9933-1003 http://www.sew-eurodrive.com.au enquires@sew-eurodrive.com.au
	Sydney	SEW-EURODRIVE PTY. LTD. 9, Sleigh Place, Wetherill Park New South Wales, 2164	Tel. +61 2 9725-9900 Fax +61 2 9725-9905 enquires@sew-eurodrive.com.au
Austria			
Assembly Sales Service	Vienna	SEW-EURODRIVE Ges.m.b.H. Richard-Strauss-Straße 24 1230 Wien	Tel. +43 1 617 55 00-0 Fax +43 1 617 55 00-30 http://www.sew-eurodrive.at sew@sew-eurodrive.at
Bangladesh			
Sales	Bangladesh	SEW-EURODRIVE INDIA PRIVATE LIMITED 345 DIT Road East Rampura Dhaka-1219, Bangladesh	Tel. +88 01729 097309 salesdhaka@seweurodrivebangladesh.com
Belarus			
Sales	Minsk	Foreign unitary production enterprise SEW- EURODRIVE RybalkoStr. 26 220033 Minsk	Tel. +375 17 298 47 56 / 298 47 58 Fax +375 17 298 47 54 http://www.sew.by sales@sew.by
Belgium			
Assembly Sales Service	Brussels	SEW-EURODRIVE n.v./s.a. Researchpark Haasrode 1060 Evenementenlaan 7 3001 Leuven	Tel. +32 16 386-311 Fax +32 16 386-336 http://www.sew-eurodrive.be info@sew-eurodrive.be
Service Competence Center	Industrial Gears	SEW-EURODRIVE n.v./s.a. Rue du Parc Industriel, 31 6900 Marche-en-Famenne	Tel. +32 84 219-878 Fax +32 84 219-879 http://www.sew-eurodrive.be service-IG@sew-eurodrive.be
Brazil			
Production Sales Service	São Paulo	SEW-EURODRIVE Brasil Ltda. Estrada Municipal José Rubim, 205 – Rodovia Santos Dumont Km 49 Indaiatuba – 13347-510 – SP	Tel. +55 19 3835-8000 sew@sew.com.br
Assembly Sales Service	Rio Claro	SEW-EURODRIVE Brasil Ltda. Rodovia Washington Luiz, Km 172 Condomínio Industrial Conpark Caixa Postal: 327 13501-600 – Rio Claro / SP	Tel. +55 19 3522-3100 Fax +55 19 3524-6653 montadora.rc@sew.com.br
	Joinville	SEW-EURODRIVE Brasil Ltda. Jvl / Ind Rua Dona Francisca, 12.346 – Pirabeiraba 89239-270 – Joinville / SC	Tel. +55 47 3027-6886 Fax +55 47 3027-6888 filial.sc@sew.com.br
Bulgaria			
Sales	Sofia	BEVER-DRIVE GmbH Bogdanovetz Str.1 1606 Sofia	Tel. +359 2 9151160 Fax +359 2 9151166 bever@bever.bg

Cameroon			
Sales	Douala	SEW-EURODRIVE S.A.R.L. Ancienne Route Bonabéri P.O. Box B.P 8674 Douala-Cameroun	Tel. +237 233 39 02 10 Fax +237 233 39 02 10 sew@sew-eurodrive-cm
Canada			
Assembly Sales Service	Toronto	SEW-EURODRIVE CO. OF CANADA LTD. 210 Walker Drive Bramalea, ON L6T 3W1	Tel. +1 905 791-1553 Fax +1 905 791-2999 http://www.sew-eurodrive.ca l.watson@sew-eurodrive.ca
	Vancouver	SEW-EURODRIVE CO. OF CANADA LTD. Tilbury Industrial Park 7188 Honeyman Street Delta, BC V4G 1G1	Tel. +1 604 946-5535 Fax +1 604 946-2513 b.wake@sew-eurodrive.ca
	Montreal	SEW-EURODRIVE CO. OF CANADA LTD. 2001 Ch. de l'Aviation Dorval Quebec H9P 2X6	Tel. +1 514 367-1124 Fax +1 514 367-3677 n.paradis@sew-eurodrive.ca
Chile			
Assembly Sales Service	Santiago de Chile	SEW-EURODRIVE CHILE LTDA Las Encinas 1295 Parque Industrial Valle Grande LAMP A Santiago de Chile P.O. Box Casilla 23 Correo Quilicura - Santiago - Chile	Tel. +56 2 2757 7000 Fax +56 2 2757 7001 http://www.sew-eurodrive.cl ventas@sew-eurodrive.cl
China			
Production Assembly Sales Service	Tianjin	SEW-EURODRIVE (Tianjin) Co., Ltd. No. 78, 13th Avenue, TEDA Tianjin 300457	Tel. +86 22 25322612 Fax +86 22 25323273 http://www.sew-eurodrive.cn info@sew-eurodrive.cn
Assembly Sales Service	Suzhou	SEW-EURODRIVE (Suzhou) Co., Ltd. 333, Suhong Middle Road Suzhou Industrial Park Jiangsu Province, 215021	Tel. +86 512 62581781 Fax +86 512 62581783 suzhou@sew-eurodrive.cn
	Guangzhou	SEW-EURODRIVE (Guangzhou) Co., Ltd. No. 9, JunDa Road East Section of GETDD Guangzhou 510530	Tel. +86 20 82267890 Fax +86 20 82267922 guangzhou@sew-eurodrive.cn
	Shenyang	SEW-EURODRIVE (Shenyang) Co., Ltd. 10A-2, 6th Road Shenyang Economic Technological Development Area Shenyang, 110141	Tel. +86 24 25382538 Fax +86 24 25382580 shenyang@sew-eurodrive.cn
	Taiyuan	SEW-EURODRIVE (Taiyuan) Co., Ltd. No.3, HuaZhang Street, TaiYuan Economic & Technical Development Zone ShanXi, 030032	Tel. +86-351-7117520 Fax +86-351-7117522 taiyuan@sew-eurodrive.cn
	Wuhan	SEW-EURODRIVE (Wuhan) Co., Ltd. 10A-2, 6th Road No. 59, the 4th Quanli Road, WEDA 430056 Wuhan	Tel. +86 27 84478388 Fax +86 27 84478389 wuhan@sew-eurodrive.cn
	Xi'An	SEW-EURODRIVE (Xi'An) Co., Ltd. No. 12 Jinye 2nd Road Xi'An High-Technology Industrial Development Zone Xi'An 710065	Tel. +86 29 68686262 Fax +86 29 68686311 xian@sew-eurodrive.cn
Sales Service	Hong Kong	SEW-EURODRIVE LTD. Unit No. 801-806, 8th Floor Hong Leong Industrial Complex No. 4, Wang Kwong Road Kowloon, Hong Kong	Tel. +852 36902200 Fax +852 36902211 contact@sew-eurodrive.hk

Colombia			
Assembly Sales Service	Bogota	SEW-EURODRIVE COLOMBIA LTDA. Calle 17 No. 132-18 Interior 2 Bodega 6, Manzana B Santafé de Bogotá	Tel. +57 1 54750-50 Fax +57 1 54750-44 http://www.sew-eurodrive.com.co sew@sew-eurodrive.com.co
Croatia			
Sales Service	Zagreb	KOMPEKS d. o. o. Zeleni dol 10 10 000 Zagreb	Tel. +385 1 4613-158 Fax +385 1 4613-158 kompeks@inet.hr
Czech Republic			
Assembly Sales Service	Hostivice	SEW-EURODRIVE CZ s.r.o. Floriánova 2459 253 01 Hostivice	Tel. +420 255 709 601 Fax +420 235 350 613 http://www.sew-eurodrive.cz sew@sew-eurodrive.cz
	Drive Service Hotline / 24 Hour Service	+420 800 739 739 (800 SEW SEW)	Service Tel. +420 255 709 632 Fax +420 235 358 218 servis@sew-eurodrive.cz
Denmark			
Assembly Sales Service	Copenhagen	SEW-EURODRIVEA/S Geminivej 28-30 2670 Greve	Tel. +45 43 95 8500 Fax +45 43 9585-09 http://www.sew-eurodrive.dk sew@sew-eurodrive.dk
Service	Vejle	SEW-EURODRIVE A/S Bødkervej 2 7100 Vejle	Tel. +45 43 9585 00 http://www.sew-eurodrive.dk sew@sew-eurodrive.dk
Egypt			
Sales Service	Cairo	Copam Egypt for Engineering & Agencies Building 10, Block 13005, First Industrial Zone, Obour City Cairo	Tel. +202 44812673 / 79 (7 lines) Fax +202 44812685 http://www.copam-egypt.com copam@copam-egypt.com
Estonia			
Sales	Tallin	ALAS-KUUL AS Loomäe tee 1, Lehmja küla 75306 Rae vald Harjumaa	Tel. +372 6593230 Fax +372 6593231 http://www.alas-kuul.ee veiko.soots@alas-kuul.ee
Finland			
Assembly Sales Service	Hollola	SEW-EURODRIVE OY Vesimäentie 4 15860 Hollola	Tel. +358 201 589-300 Fax +358 3 780-6211 http://www.sew-eurodrive.fi sew@sew.fi
Service	Hollola	SEW-EURODRIVE OY Keskikankaantie 21 15860 Hollola	Tel. +358 201 589-300 Fax +358 3 780-6211 http://www.sew-eurodrive.fi sew@sew.fi
	Tornio	SEW-EURODRIVE Oy Lossirannankatu 5 95420 Tornio	Tel. +358 201 589 300 Fax +358 3 780 6211 http://www.sew-eurodrive.fi sew@sew.fi
Production Assembly	Karkkila	SEW Industrial Gears Oy Santasalonkatu 6, PL 8 03620 Karkkila, 03601 Karkkila	Tel. +358 201 589-300 Fax +358 201 589-310 http://www.sew-eurodrive.fi sew@sew.fi
France			
Production Sales Service	Hagenau	SEW USOCOME 48-54 route de Soufflenheim B. P. 20185 67506 Hagenau Cedex	Tel. +33 3 88 73 67 00 Fax +33 3 88 73 66 00 http://www.usocome.com sew@usocome.com
Production	Forbach	SEW USOCOME Zone industrielle Technopôle Forbach Sud B. P. 30269 57604 Forbach Cedex	Tel. +33 3 87 29 38 00

France			
	Brumath	SEW USOCOME 1 Rue de Bruxelles 67670 Mommenheim Cedex	Tel. +33 3 88 37 48 00
Assembly Sales Service	Bordeaux	SEW USOCOME Parc d'activités de Magellan 62 avenue de Magellan – B. P. 182 33607 Pessac Cedex	Tel. +33 5 57 26 39 00 Fax +33 5 57 26 39 09
	Lyon	SEW USOCOME 75 rue Antoine Condorcet 38090 Vaulx-Milieu	Tel. +33 4 74 99 60 00 Fax +33 4 74 99 60 15
	Nantes	SEW USOCOME Parc d'activités de la forêt 4 rue des Fontenelles 44140 Le Bignon	Tel. +33 2 40 78 42 00 Fax +33 2 40 78 42 20
	Paris	SEW USOCOME Zone industrielle 2 rue Denis Papin 77390 Verneuil l'Étang	Tel. +33 1 64 42 40 80 Fax +33 1 64 42 40 88
Gabon			
Representation: Cameroon			
Germany			
Headquarters Production Sales	Bruchsal	SEW-EURODRIVE GmbH & Co KG Ernst-Blickle-Straße 42 76646 Bruchsal	Tel. +49 7251 75-0 Fax +49 7251 75-1970 http://www.sew-eurodrive.de sew@sew-eurodrive.de
Production / Industrial Gears	Bruchsal	SEW-EURODRIVE GmbH & Co KG Christian-Pähr-Str. 10 76646 Bruchsal	Tel. +49 7251 75-0 Fax +49 7251 75-2970
Production	Graben	SEW-EURODRIVE GmbH & Co KG Ernst-Blickle-Straße 1 76676 Graben-Neudorf	Tel. +49 7251 75-0 Fax +49 7251-2970
	Östringen	SEW-EURODRIVE GmbH & Co KG, Werk Östringen Franz-Gurk-Straße 2 76684 Östringen	Tel. +49 7253 9254-0 Fax +49 7253 9254-90 oestringen@sew-eurodrive.de
Service Competence Center	Mechanics / Mechatronics	SEW-EURODRIVE GmbH & Co KG Ernst-Blickle-Straße 1 76676 Graben-Neudorf	Tel. +49 7251 75-1710 Fax +49 7251 75-1711 scc-mechanik@sew-eurodrive.de
	Electronics	SEW-EURODRIVE GmbH & Co KG Ernst-Blickle-Straße 42 76646 Bruchsal	Tel. +49 7251 75-1780 Fax +49 7251 75-1769 scc-elektronik@sew-eurodrive.de
Drive Technology Center	North	SEW-EURODRIVE GmbH & Co KG Alte Ricklinger Straße 43 30823 Garbsen (Hannover)	Tel. +49 5137 8798-30 Fax +49 5137 8798-55 dtc-nord@sew-eurodrive.de
	East	SEW-EURODRIVE GmbH & Co KG Dänkritzter Weg 1 08393 Meerane (Zwickau)	Tel. +49 3764 7606-0 Fax +49 3764 7606-20 dtc-ost@sew-eurodrive.de
	South	SEW-EURODRIVE GmbH & Co KG Domagkstraße 5 85551 Kirchheim (München)	Tel. +49 89 909551-21 Fax +49 89 909551-50 dtc-sued@sew-eurodrive.de
	West	SEW-EURODRIVE GmbH & Co KG Siemensstraße 1 40764 Langenfeld (Düsseldorf)	Tel. +49 2173 8507-10 Fax +49 2173 8507-50 dtc-west@sew-eurodrive.de
Drive Center	Berlin	SEW-EURODRIVE GmbH & Co KG Alexander-Meißner-Straße 44 12526 Berlin	Tel. +49 306331131-30 Fax +49 306331131-36 dc-berlin@sew-eurodrive.de
	Hamburg	SEW-EURODRIVE GmbH & Co KG Hasselbinnen 44 22869 Schenefeld	Tel. +49 40298109-60 Fax +49 40298109-70 dc-hamburg@sew-eurodrive.de
	Ludwigshafen	SEW-EURODRIVE GmbH & Co KG c/o BASF SE c/o BASF SE Gebäude W130 67056 Ludwigshafen	Tel. +49 7251 75 3759 Fax +49 7251 75 503759 dc-ludwigshafen@sew-eurodrive.de

Germany			
	Saarland	SEW-EURODRIVE GmbH & Co KG Gottlieb-Daimler-Straße 4 66773 Schwalbach Saar – Hülzweiler	Tel. +49 6831 48946 10 Fax +49 6831 48946 13 dc-saarland@sew-eurodrive.de
	Ulm	SEW-EURODRIVE GmbH & Co KG Dieselstraße 18 89160 Dornstadt	Tel. +49 7348 9885-0 Fax +49 7348 9885-90 dc-ulm@sew-eurodrive.de
	Würzburg	SEW-EURODRIVE GmbH & Co KG Nürnbergerstraße 118 97076 Würzburg-Lengfeld	Tel. +49 931 27886-60 Fax +49 931 27886-66 dc-wuerzburg@sew-eurodrive.de
Drive Service Hotline / 24 Hour Service			0 800 SEWHELP 0 800 7394357
Great Britain			
Assembly Sales Service	Normanton	SEW-EURODRIVE Ltd. DeVilliers Way Trident Park Normanton West Yorkshire WF6 1GX	Tel. +44 1924 893-855 Fax +44 1924 893-702 http://www.sew-eurodrive.co.uk info@sew-eurodrive.co.uk
Drive Service Hotline / 24 Hour Service			Tel. 01924 896911
Greece			
Sales	Athens	Christ. Boznos & Son S.A. 12, K. Mavromichali Street P.O. Box 80136 18545 Piraeus	Tel. +30 2 1042 251-34 Fax +30 2 1042 251-59 http://www.boznos.gr info@boznos.gr
Hungary			
Sales Service	Budapest	SEW-EURODRIVE Kft. Csillaghegyi út 13. 1037 Budapest	Tel. +36 1 437 06-58 Fax +36 1 437 06-50 http://www.sew-eurodrive.hu office@sew-eurodrive.hu
Iceland			
Sales	Reykjavik	Varma & Vélaverk ehf. Knarrarvogi 4 104 Reykjavik	Tel. +354 585 1070 Fax +354 585)1071 http://www.varmaverk.is vov@vov.is
India			
Registered Office Assembly Sales Service	Vadodara	SEW-EURODRIVE India Private Limited Plot No. 4, GIDC POR Ramangamdi • Vadodara - 391 243 Gujarat	Tel. +91 265 3045200 Fax +91 265 3045300 http://www.seweurodriveindia.com salesvadodara@seweurodriveindia.com
Assembly Sales Service	Chennai	SEW-EURODRIVE India Private Limited Plot No. K3/1, Sipcot Industrial Park Phase II Mambakkam Village Sriperumbudur - 602105 Kancheepuram Dist, Tamil Nadu	Tel. +91 44 37188888 Fax +91 44 37188811 saleschennai@seweurodriveindia.com
	Pune	SEW-EURODRIVE India Private Limited Plant: Plot No. D236/1, Chakan Industrial Area Phase- II, Warale, Tal- Khed, Pune-410501, Maharashtra	Tel. +91 21 35 628700 Fax +91 21 35 628715 salespune@seweurodriveindia.com
Sales Service	Gurgaon	SEW-EURODRIVE India Private Limited Drive Center Gurugram Plot no 395, Phase-IV, UdyogVihar Gurugram , 122016 Haryana	Tel. +91 99588 78855 salesgurgaon@seweurodriveindia.com
Indonesia			
Sales	Medan	PT. Serumpun Indah Lestari Jl.Pulau Solor no. 8, Kawasan Industri Medan II Medan 20252	Tel. +62 61 687 1221 Fax +62 61 6871429 / +62 61 6871458 / +62 61 30008041 sil@serumpunindah.com serumpunindah@yahoo.com http://www.serumpunindah.com

Indonesia			
	Jakarta	PT. Cahaya Sukses Abadi Komplek Rukan Puri Mutiara Blok A no 99, Sunter Jakarta 14350	Tel. +62 21 65310599 Fax +62 21 65310600 csajkt@cbn.net.id
	Jakarta	PT. Agrindo Putra Lestari JL.Pantai Indah Selatan, Komplek Sentra In- dustri Terpadu, Pantai indah Kapuk Tahap III, Blok E No. 27 Jakarta 14470	Tel. +62 21 2921-8899 Fax +62 21 2921-8988 aplindo@indosat.net.id http://www.aplindo.com
	Surabaya	PT. TRIAGRI JAYA ABADI Jl. Sukosemolo No. 63, Galaxi Bumi Permai G6 No. 11 Surabaya 60111	Tel. +62 31 5990128 Fax +62 31 5962666 sales@triagri.co.id http://www.triagri.co.id
	Surabaya	CV. Multi Mas Jl. Raden Saleh 43A Kav. 18 Surabaya 60174	Tel. +62 31 5458589 Fax +62 31 5317220 sianhwa@sby.centrin.net.id http://www.cvmultimas.com
Ireland			
Sales Service	Dublin	Alperon Engineering Ltd. 48 Moyle Road Dublin Industrial Estate Glasnevin, Dublin 11	Tel. +353 1 830-6277 Fax +353 1 830-6458 http://www.alperon.ie info@alperon.ie
Israel			
Sales	Tel Aviv	Liraz Handasa Ltd. Ahofer Str 34B / 228 58858 Holon	Tel. +972 3 5599511 Fax +972 3 5599512 http://www.liraz-handasa.co.il office@liraz-handasa.co.il
Italy			
Assembly Sales Service	Milan	SEW-EURODRIVE S.a.s. di SEW S.r.l. & Co. Via Bernini,12 20020 Solaro (Milano)	Tel. +39 02 96 980229 Fax +39 02 96 980 999 http://www.sew-eurodrive.it milano@sew-eurodrive.it
Ivory Coast			
Sales	Abidjan	SEW-EURODRIVE SARL Ivory Coast Rue des Pêcheurs, Zone 3 26 BP 916 Abidjan 26	Tel. +225 21 21 81 05 Fax +225 21 25 30 47 info@sew-eurodrive.ci http://www.sew-eurodrive.ci
Japan			
Assembly Sales Service	Iwata	SEW-EURODRIVE JAPAN CO., LTD 250-1, Shimoman-no, Iwata Shizuoka 438-0818	Tel. +81 538 373811 Fax +81 538 373814 http://www.sew-eurodrive.co.jp sewjapan@sew-eurodrive.co.jp
Kazakhstan			
Sales Service	Almaty	SEW-EURODRIVE LLP 291-291A, Tole bi street 050031, Almaty	Tel. +7 (727) 350 5156 Fax +7 (727) 350 5156 http://www.sew-eurodrive.kz sew@sew-eurodrive.kz
	Tashkent	SEW-EURODRIVE LLP Representative office in Uzbekistan 96A, Sharaf Rashidov street, Tashkent, 100084	Tel. +998 71 2359411 Fax +998 71 2359412 http://www.sew-eurodrive.uz sew@sew-eurodrive.uz
	Ulaanbaatar	IM Trading LLC Olympic street 28B/3 Sukhbaatar district, Ulaanbaatar 14230, MN	Tel. +976-77109997 Fax +976-77109997 imt@imt.mn
Latvia			
Sales	Riga	SIA Alas-Kuul Katlakalna 11C 1073 Riga	Tel. +371 6 7139253 Fax +371 6 7139386 http://www.alas-kuul.lv info@alas-kuul.com

Lebanon			
Sales (Lebanon)	Beirut	Gabriel Acar & Fils sarl B. P. 80484 Bourj Hammoud, Beirut	Tel. +961 1 510 532 Fax +961 1 494 971 ssacar@inco.com.lb
Sales (Jordan, Kuwait , Beirut Saudi Arabia, Syria)		Middle East Drives S.A.L. (offshore) Sin El Fil. B. P. 55-378 Beirut	Tel. +961 1 494 786 Fax +961 1 494 971 http://www.medrives.com info@medrives.com
Lithuania			
Sales	Alytus	UAB Irseva Statybininku 106C 63431 Alytus	Tel. +370 315 79204 Fax +370 315 56175 http://www.irseva.lt irmantas@irseva.lt
Luxembourg			
Representation: Belgium			
Macedonia			
Sales	Skopje	Boznos DOOEL Dime Anicin 2A/7A 1000 Skopje	Tel. +389 23256553 Fax +389 23256554 http://www.boznos.mk
Malaysia			
Assembly Sales Service	Johor	SEW-EURODRIVE SDN BHD No. 95, Jalan Seroja 39, Taman Johor Jaya 81000 Johor Bahru, Johor West Malaysia	Tel. +60 7 3549409 Fax +60 7 3541404 sales@sew-eurodrive.com.my
Mexico			
Assembly Sales Service	Quéretaro	SEW-EURODRIVE MEXICO S.A. de C.V. SEM-981118-M93 Tequisquiapan No. 102 Parque Industrial Quéretaro C.P. 76220 Querétaro, México	Tel. +52 442 1030-300 Fax +52 442 1030-301 http://www.sew-eurodrive.com.mx scmexico@seweurodrive.com.mx
Sales Service	Puebla	SEW-EURODRIVE MEXICO S.A. de C.V. Calzada Zavaleta No. 3922 Piso 2 Local 6 Col. Santa Cruz Buenavista C.P. 72154 Puebla, México	Tel. +52 (222) 221 248 http://www.sew-eurodrive.com.mx scmexico@seweurodrive.com.mx
Mongolia			
Technical Office	Ulaanbaatar	IM Trading LLC Olympic street 28B/3 Sukhbaatar district, Ulaanbaatar 14230, MN	Tel. +976-77109997 Tel. +976-99070395 Fax +976-77109997 http://imt.mn/ imt@imt.mn
Morocco			
Sales Service Assembly	Bouskoura	SEW-EURODRIVE Morocco SARL Parc Industriel CFCIM, Lot. 55/59 27182 Bouskoura Grand Casablanca	Tel. +212 522 88 85 00 Fax +212 522 88 84 50 http://www.sew-eurodrive.ma sew@sew-eurodrive.ma
Namibia			
Sales	Swakopmund	DB MINING & INDUSTRIAL SUPPLIES CC Einstein Street Strauss Industrial Park Unit1 Swakopmund	Tel. +264 64 462 738 Fax +264 64 462 734 anton@dbminingnam.com
Netherlands			
Assembly Sales Service	Rotterdam	SEW-EURODRIVE B.V. Industrieweg 175 3044 AS Rotterdam Postbus 10085 3004 AB Rotterdam	Tel. +31 10 4463-700 Fax +31 10 4155-552 Service: 0800-SEWHELP http://www.sew-eurodrive.nl info@sew-eurodrive.nl

New Zealand

Assembly Sales Service	Auckland	SEW-EURODRIVE NEW ZEALAND LTD. P.O. Box 58-428 82 Greenmount drive East Tamaki Auckland	Tel. +64 9 2745627 Fax +64 9 2740165 http://www.sew-eurodrive.co.nz sales@sew-eurodrive.co.nz
	Christchurch	SEW-EURODRIVE NEW ZEALAND LTD. 30 Lodestar Avenue, Wigram Christchurch	Tel. +64 3 384-6251 Fax +64 3 384-6455 sales@sew-eurodrive.co.nz

Nigeria

Sales	Lagos	Greenpeg Nig. Ltd Plot 296A, Adeyemo Akapo Str. Omole GRA Ikeja Lagos-Nigeria	Tel. +234-701-821-9200-1 http://www.greenpeg ltd.com bolaji.adekunle@greenpeg ltd.com
-------	-------	---	---

Norway

Assembly Sales Service	Moss	SEW-EURODRIVE A/S Solgaard skog 71 1599 Moss	Tel. +47 69 24 10 20 Fax +47 69 24 10 40 http://www.sew-eurodrive.no sew@sew-eurodrive.no
------------------------------	------	--	--

Pakistan

Sales	Karachi	Industrial Power Drives Al-Fatah Chamber A/3, 1st Floor Central Com- mercial Area, Sultan Ahmed Shah Road, Block 7/8, Karachi	Tel. +92 21 452 9369 Fax +92-21-454 7365 sew eurodrive@cyber.net.pk
-------	---------	---	---

Paraguay

Sales	Fernando de la Mora	SEW-EURODRIVE PARAGUAY S.R.L De la Victoria 112, Esquina nueva Asunción Departamento Central Fernando de la Mora, Barrio Bernardino	Tel. +595 991 519695 Fax +595 21 3285539 sewpy@sew-eurodrive.com.py
-------	---------------------	--	---

Peru

Assembly Sales Service	Lima	SEW EURODRIVE DEL PERU S.A.C. Los Calderos, 120-124 Urbanizacion Industrial Vulcano, ATE, Lima	Tel. +51 1 3495280 Fax +51 1 3493002 http://www.sew-eurodrive.com.pe sewperu@sew-eurodrive.com.pe
------------------------------	------	--	--

Philippines

Sales	Makati	P.T. Cerna Corporation 4137 Ponte St., Brgy. Sta. Cruz Makati City 1205	Tel. +63 2 519 6214 Fax +63 2 890 2802 mech_drive_sys@ptcerna.com http://www.ptcerna.com
-------	--------	---	--

Poland

Assembly Sales Service	Łódź	SEW-EURODRIVE Polska Sp.z.o.o. ul. Techniczna 5 92-518 Łódź	Tel. +48 42 293 00 00 Fax +48 42 293 00 49 http://www.sew-eurodrive.pl sew@sew-eurodrive.pl
	Service	Tel. +48 42 293 0030 Fax +48 42 293 0043	24 Hour Service Tel. +48 602 739 739 (+48 602 SEW SEW) serwis@sew-eurodrive.pl

Portugal

Assembly Sales Service	Coimbra	SEW-EURODRIVE, LDA. Av. da Fonte Nova, n.º 86 3050-379 Mealhada	Tel. +351 231 20 9670 Fax +351 231 20 3685 http://www.sew-eurodrive.pt info sew@sew-eurodrive.pt
------------------------------	---------	---	---

Romania

Sales Service	Bucharest	Sialco Trading SRL str. Brazilia nr. 36 011783 Bucuresti	Tel. +40 21 230-1328 Fax +40 21 230-7170 sialco@sialco.ro
------------------	-----------	--	---

Russia			
Assembly Sales Service	St. Petersburg	ЗАО «СЕВ-ЕВРОДРАЙФ» 188660, Russia, Leningrad Region, Vse- volozhsky District, Korabselki, Aleksandra Nevskogo str. building 4, block 1 P.O. Box 36 195220 St. Petersburg	Tel. +7 812 3332522 / +7 812 5357142 Fax +7 812 3332523 http://www.sew-eurodrive.ru sew@sew-eurodrive.ru
Senegal			
Sales	Dakar	SENEMECA Mécanique Générale Km 8, Route de Rufisque B.P. 3251, Dakar	Tel. +221 338 494 770 Fax +221 338 494 771 http://www.senemeca.com senemeca@senemeca.sn
Serbia			
Sales	Belgrade	DIPAR d.o.o. Ustanicka 128a PC Košum, IV floor 11000 Beograd	Tel. +381 11 347 3244 / +381 11 288 0393 Fax +381 11 347 1337 office@dipar.rs
Singapore			
Assembly Sales Service	Singapore	SEW-EURODRIVE PTE. LTD. No 9, Tuas Drive 2 Jurong Industrial Estate Singapore 638644	Tel. +65 68621701 Fax +65 68612827 http://www.sew-eurodrive.com.sg sewsingapore@sew-eurodrive.com
Slovakia			
Sales	Bernolákovo	SEW-Eurodrive SK s.r.o. Priemyselná ulica 6267/7 900 27 Bernolákovo	Tel.+421 2 33595 202, 217, 201 Fax +421 2 33595 200 http://www.sew-eurodrive.sk sew@sew-eurodrive.sk
Slovenia			
Sales Service	Celje	Pakman - Pogonska Tehnika d.o.o. Ul. XIV. divizije 14 3000 Celje	Tel. +386 3 490 83-20 Fax +386 3 490 83-21 pakman@siol.net
South Africa			
Assembly Sales Service	Johannesburg	SEW-EURODRIVE (PROPRIETARY) LIMITED Eurodrive House Cnr. Adcock Ingram and Aerodrome Roads Aeroton Ext. 2 Johannesburg 2013 P.O.Box 90004 Bertsham 2013	Tel. +27 11 248-7000 Fax +27 11 248-7289 http://www.sew.co.za info@sew.co.za
	Cape Town	SEW-EURODRIVE (PROPRIETARY) LIMITED Rainbow Park Cnr. Racecourse & Omuramba Road Montague Gardens Cape Town P.O.Box 36556 Chempet 7442	Tel. +27 21 552-9820 Fax +27 21 552-9830 Telex 576 062 bgriffiths@sew.co.za
	Durban	SEW-EURODRIVE (PROPRIETARY) LIMITED 48 Prospecton Road Isipingo Durban P.O. Box 10433, Ashwood 3605	Tel. +27 31 902 3815 Fax +27 31 902 3826 cdejager@sew.co.za
	Nelspruit	SEW-EURODRIVE (PROPRIETARY) LIMITED 7 Christie Crescent Vintonia P.O.Box 1942 Nelspruit 1200	Tel. +27 13 752-8007 Fax +27 13 752-8008 robermeyer@sew.co.za
South Korea			
Assembly Sales Service	Ansan	SEW-EURODRIVE KOREA CO., LTD. 7, Dangjaengi-ro, Danwon-gu, Ansan-si, Gyeonggi-do, Zip 425-839	Tel. +82 31 492-8051 Fax +82 31 492-8056 http://www.sew-eurodrive.kr master.korea@sew-eurodrive.com

South Korea

Busan	SEW-EURODRIVE KOREA CO., LTD. 28, Noksansandan 262-ro 50beon-gil, Gangseo-gu, Busan, Zip 618-820	Tel. +82 51 832-0204 Fax +82 51 832-0230
-------	---	---

Spain

Assembly Sales Service	Bilbao	SEW-EURODRIVE ESPAÑA, S.L. Parque Tecnológico, Edificio, 302 48170 Zamudio (Vizcaya)	Tel. +34 94 43184-70 http://www.sew-eurodrive.es sew.spain@sew-eurodrive.es
------------------------------	--------	--	---

Sri Lanka

Sales	Colombo	SM International (Pte) Ltd 254, Galle Raod Colombo 4, Sri Lanka	Tel. +94 1 2584887 Fax +94 1 2582981
-------	---------	---	---

Swaziland

Sales	Manzini	C G Trading Co. (Pty) Ltd Simunye street Matsapha, Manzini	Tel. +268 7602 0790 Fax +268 2 518 5033 charles@cgtrading.co.sz www.cgtradingswaziland.com
-------	---------	--	--

Sweden

Assembly Sales Service	Jönköping	SEW-EURODRIVE AB Gnejsvägen 6-8 553 03 Jönköping Box 3100 S-550 03 Jönköping	Tel. +46 36 34 42 00 Fax +46 36 34 42 80 http://www.sew-eurodrive.se jonkoping@sew.se
------------------------------	-----------	---	--

Switzerland

Assembly Sales Service	Basel	Alfred Imhof A.G. Jurastrasse 10 4142 Münchenstein bei Basel	Tel. +41 61 417 1717 Fax +41 61 417 1700 http://www.imhof-sew.ch info@imhof-sew.ch
------------------------------	-------	--	--

Taiwan

Sales	Taipei	Ting Shou Trading Co., Ltd. 6F-3, No. 267, Sec. 2 Tung Huw S. Road Taipei	Tel. +886 2 27383535 Fax +886 2 27368268 Telex 27 245 sewtwn@ms63.hinet.net http://www.tingshou.com.tw
	Nan Tou	Ting Shou Trading Co., Ltd. No. 55 Kung Yeh N. Road Industrial District Nan Tou 540	Tel. +886 49 255353 Fax +886 49 257878 sewtwn@ms63.hinet.net http://www.tingshou.com.tw

Tanzania

Sales	Daressalam	SEW-EURODRIVE PTY LIMITED TANZANIA Plot 52, Regent Estate PO Box 106274 Dar Es Salaam	Tel. +255 0 22 277 5780 Fax +255 0 22 277 5788 http://www.sew-eurodrive.co.tz info@sew.co.tz
-------	------------	--	--

Thailand

Assembly Sales Service	Chonburi	SEW-EURODRIVE (Thailand) Ltd. 700/456, Moo.7, Donhuaroh Muang Chonburi 20000	Tel. +66 38 454281 Fax +66 38 454288 sewthailand@sew-eurodrive.com
------------------------------	----------	---	---

Tunisia

Sales	Tunis	T. M.S. Technic Marketing Service Zone Industrielle Mghira 2 Lot No. 39 2082 Fouchana	Tel. +216 79 40 88 77 Fax +216 79 40 88 66 http://www.tms.com.tn tms@tms.com.tn
-------	-------	--	--

Turkey

Assembly Sales Service	Kocaeli-Gebze	SEW-EURODRIVE Ana Merkez Gebze Organize Sanayi Böl. 400 Sok No. 401 41480 Gebze Kocaeli	Tel. +90 262 9991000 04 Fax +90 262 9991009 http://www.sew-eurodrive.com.tr sew@sew-eurodrive.com.tr
------------------------------	---------------	---	---

Ukraine

Assembly Sales Service	Dnipropetrovsk	SEW-EURODRIVE, LLC Robochya str., bld. 23-B, office 409 49008 Dnipro	Tel. +380 56 370 3211 Fax +380 56 372 2078 http://www.sew-eurodrive.ua sew@sew-eurodrive.ua
------------------------------	----------------	--	--

United Arab Emirates

Drive Technology Center	Dubai	SEW-EURODRIVE FZE PO Box 263835 Jebel Ali Free Zone – South, P.O. Box Dubai, United Arab Emirates	Tel. +971 (0)4 8806461 Fax +971 (0)4 8806464 info@sew-eurodrive.ae
----------------------------	-------	---	---

Uruguay

Assembly Sales	Montevideo	SEW-EURODRIVE Uruguay, S. A. Jose Serrato 3569 Esquina Corumbe CP 12000 Montevideo	Tel. +598 2 21181-89 Fax +598 2 21181-90 sewuy@sew-eurodrive.com.uy
-------------------	------------	--	---

USA

Production Assembly Sales Service	Southeast Region	SEW-EURODRIVE INC. 1295 Old Spartanburg Highway P.O. Box 518 Lyman, S.C. 29365	Tel. +1 864 439-7537 Fax Sales +1 864 439-7830 Fax Production +1 864 439-9948 Fax Assembly +1 864 439-0566 Fax Confidential/HR +1 864 949-5557 http://www.seweurodrive.com cslyman@seweurodrive.com
Assembly Sales Service	Northeast Region	SEW-EURODRIVE INC. Pureland Ind. Complex 2107 High Hill Road, P.O. Box 481 Bridgeport, New Jersey 08014	Tel. +1 856 467-2277 Fax +1 856 845-3179 csbridgeport@seweurodrive.com
	Midwest Region	SEW-EURODRIVE INC. 2001 West Main Street Troy, Ohio 45373	Tel. +1 937 335-0036 Fax +1 937 332-0038 cstroy@seweurodrive.com
	Southwest Region	SEW-EURODRIVE INC. 3950 Platinum Way Dallas, Texas 75237	Tel. +1 214 330-4824 Fax +1 214 330-4724 csdallas@seweurodrive.com
	Western Region	SEW-EURODRIVE INC. 30599 San Antonio St. Hayward, CA 94544	Tel. +1 510 487-3560 Fax +1 510 487-6433 cshayward@seweurodrive.com
	Wellford	SEW-EURODRIVE INC. 148/150 Finch Rd. Wellford, S.C. 29385	Tel. +1 864 439-7537 Fax +1 864 661 1167 IGOrders@seweurodrive.com

Additional addresses for service provided on request!

Vietnam

Sales	Ho Chi Minh City	SEW-EURODRIVE PTE. LTD. RO at Hochim- inh City Floor 8, KV I, Loyal building, 151-151 Bis Vo Thi Sau street, ward 6, District 3, Ho Chi Minh City, Vietnam	Tel. +84 937 299 700 huytam.phan@sew-eurodrive.com
	Hanoi	MICO LTD Quảng Trị - North Vietnam / All sectors except Construction Materials 8th Floor, Ocean Park Building, 01 Dao Duy Anh St, Ha Noi, Viet Nam	Tel. +84 4 39386666 Fax +84 4 3938 6888 nam_ph@micogroup.com.vn http://www.micogroup.com.vn

Zambia

Representation: South Africa

Index

Numerical

3-wire control	57
87 Hz characteristic (50 Hz motors)	56

A

AC brakemotors, connection	30
Access to parameter group 0	79
Advanced parameters	83
Ambient conditions	113
Ambient temperature	113
Automatic measuring procedure	47

B

Basic parameters	82
Braking resistor	
Connection	28

C

Cable length, permitted	68
Communication socket RJ45	38
Configuration of the inverters for speed synchron- ism	54
Configuration parameters	79
Conformity	113
Connecting the signal terminals at the inverter ...	67
Connection	
Braking resistor	28
Inverter and motor	38
Control cabinet, installation	19
Control word	67
Cooling	
Derating	12
Installation altitude	12
Copyright notice	8

D

Derating	12
Description of parameter group 0	80
Designated use	11
Device structure	15
Dimensions	124
IP20/NEMA-1 housing	124
IP66-NEMA-4X housing	125

E

Electrical installation	13, 22, 69
Before installation	23
Safety notes	13
Electromagnetic compatibility	32
Interference emission	33
Interference immunity	32
Electronics Service	126
Embedded safety notes	8
EMC standards for interference emission	113
Emergency code objects	76
Engineering software	
MOVITOOLS® MotionStudio	45
Error clearance	60
Error diagnostics	60
Error history	60
Error list	
Service	61
Explanation of the parameters	85
Extended storage	126

F

Factory setting, parameter reset	42
Fire mode/emergency mode	55

G

Group drive	30
-------------------	----

H

Help card	27
Housing variants	124

I

Input voltage ranges	122
Installation	18
Electrical	22
Inverter and motor connection	38
Safety notes	12
Installation notes	
Derating	12
Installation altitude > 1000 m	12
Installation with IP66 housing	21
Inverter status	59

IP20/NEMA-1 housing		P-12 Control signal source	88
Assembly	19	P-14 Extended parameter access	89
IP66 installation	21	P-15 Digital input function selection	89
IT systems	25	P-16 Analog input 1 format	94
K		P-17 PWM switching frequency	95
Keypad mode, startup	52	P-18 User relay output function selection	96
L		P-19 Limit value for relay/analog output	97
Line contactors	23	P-20 Fixed setpoint speed 1	97
LT Shell software	43	P-21 Fixed setpoint speed 2	97
M		P-22 Fixed setpoint speed 3	97
Mains fuses	24	P-23 Fixed setpoint speed 4	97
Master-slave mode	54	P-24 Second deceleration ramp, rapid stop ramp	97
Mechanical installation	19	P-25 Analog output/digital output function selection	98
Motor connection	30	P-26/P-27 Skip frequency band/skip frequency ..	99
Motor potentiometer	57	P-28/P-29 V/f characteristic curve adjustment ..	100
Multi-motor drive/group drive	30	P-30 Start mode selection	101
N		P-31 Enable behavior/changeover behavior for keypad/fieldbus	101
Notes		P-32 DC hold function	103
Designation in the documentation	7	P-33 Flying start function enable	103
O		P-34 Brake chopper activation	103
Operation	59	P-35 Analog input 1/slave scaling	104
On the IT system	25	P-36 Fieldbus settings	105
Safety notes	14	P-37 Extended parameter access code definition	106
Operation at 87 Hz characteristic	56	P-38 Parameter lock	106
Output power with EMC filter	115	P-39 Analog input 1 offset	106
Overload	123	P-40 Actual speed value scaling factor	106
Overview of parameters	79	P-41 Thermal motor protection to UL508C	106
Overview of signal terminals	36	P-42 PI proportional gain	107
P		P-43 PI integral time constant	107
P-00 Configuration parameters	112	P-44 PI operating mode	107
P-01 Maximum speed	85	P-45 PI reference selection	107
P-02 Minimum speed	85	P-46 PI fixed setpoint reference	107
P-03 Acceleration ramp time	85	P-47 Analog input 2 format	108
P-04 Deceleration ramp time	85	P-48 Standby mode	108
P-05 Stop mode	86	P-49 PI control difference wake-up level	108
P-06 Energy-saving function	86	P-50 Hysteresis band user relay	108
P-07 Rated motor voltage	86	P-51 Operating mode/motor control	109
P-08 Rated motor current	87	P-52 Auto tune	109
P-09 Rated motor frequency	87	P-53 Controller parameter	110
P-10 Rated motor speed	87	P-53 Level 1: Speed controller proportional gain	110
P-11 Voltage increase	88	P-53 Level 2: Speed controller integrating time constant	110

P-54 Current limit	110	Section-related safety notes	7
P-55 Motor stator resistance (Rs)	111	Separation, protective	13
P-56 Motor stator inductance (Lsd)	111	Service	126
P-57 Motor stator inductance (Lsq) – only for syn- chronous motors.....	111	Error diagnostics	60
P-58 DC braking speed	112	Error history	60
P-59 Current strength of DC holding function ...	112	Signal words in the safety notes.....	7
P-60 Fire mode/emergency mode speed	112	Slip compensation	47, 87
Parameter settings for the inverter	67	Startup	41, 47
Parameters	79	Keypad mode	52
Real time monitoring	79	PI controller mode	52
PI controller mode, startup	52	Safety notes	14
Process data	67	Startup	47
Process input words	66	Terminal mode (factory setting).....	51
Process output words	65	Status word	67
Product names	8	Structure and settings of process data words	65
Protection function.....	123	T	
Protective separation.....	13	Target group	10
R		Technical data	113
Realtime monitoring	79	Terminal mode, startup	51
Repair	126	Thermal motor protection TF, TH	29
Restriction of use.....	12	Trademarks	8
Rights to claim under limited warranty	8	Transport	11
RJ45 communication socket	38	Type designation	15
S		U	
Safety notes		Use	11
Designation in the documentation	7	User Interface	41
Installation	12	Keypad	41
Installation altitude > 1000 m	12	UZ DC link connection.....	38
Preliminary information.....	9	W	
Setup	12	Waste disposal	127
Structure of embedded.....	8	Wiring diagram	
Structure of the section-related	7	Braking resistor	40

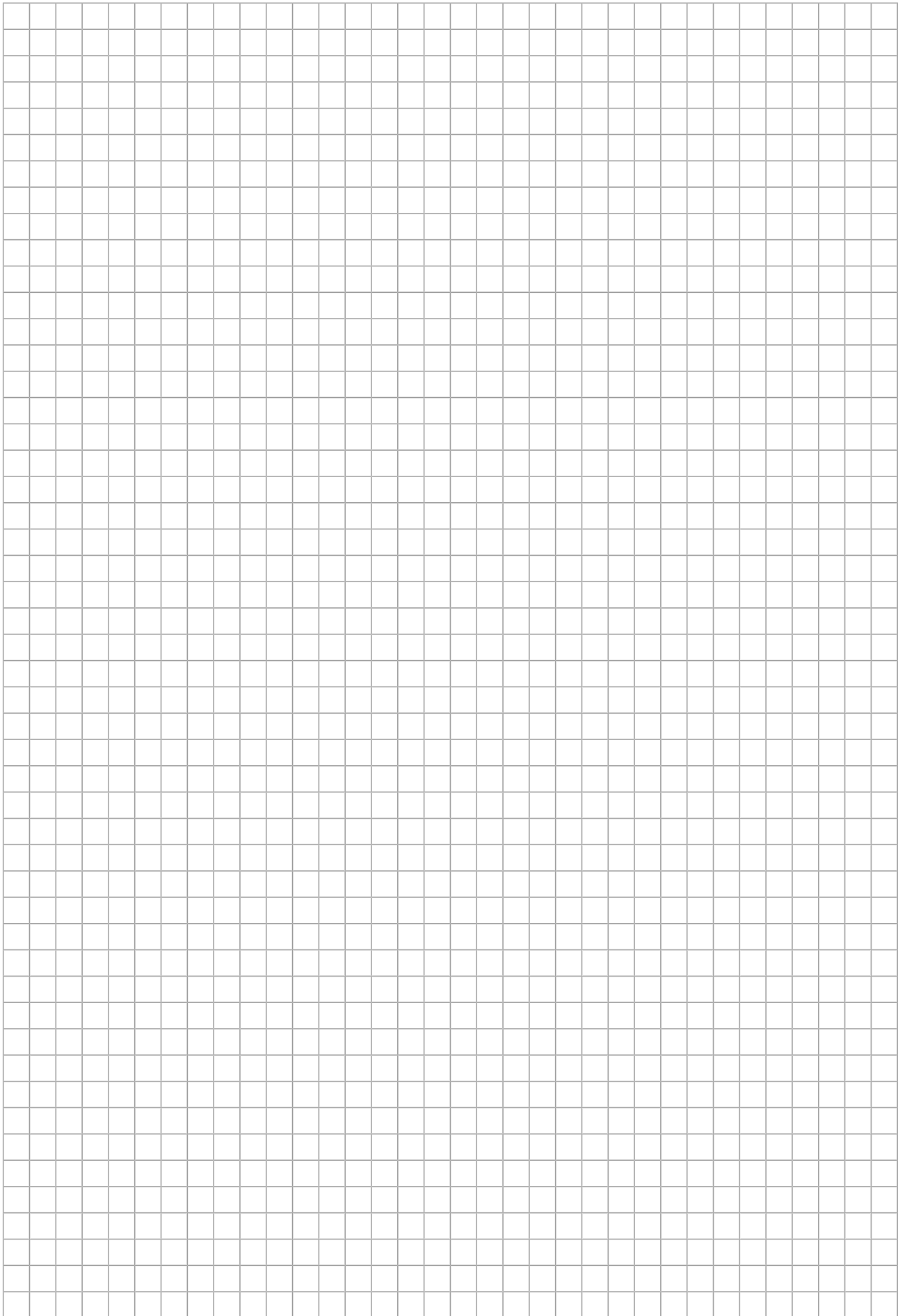

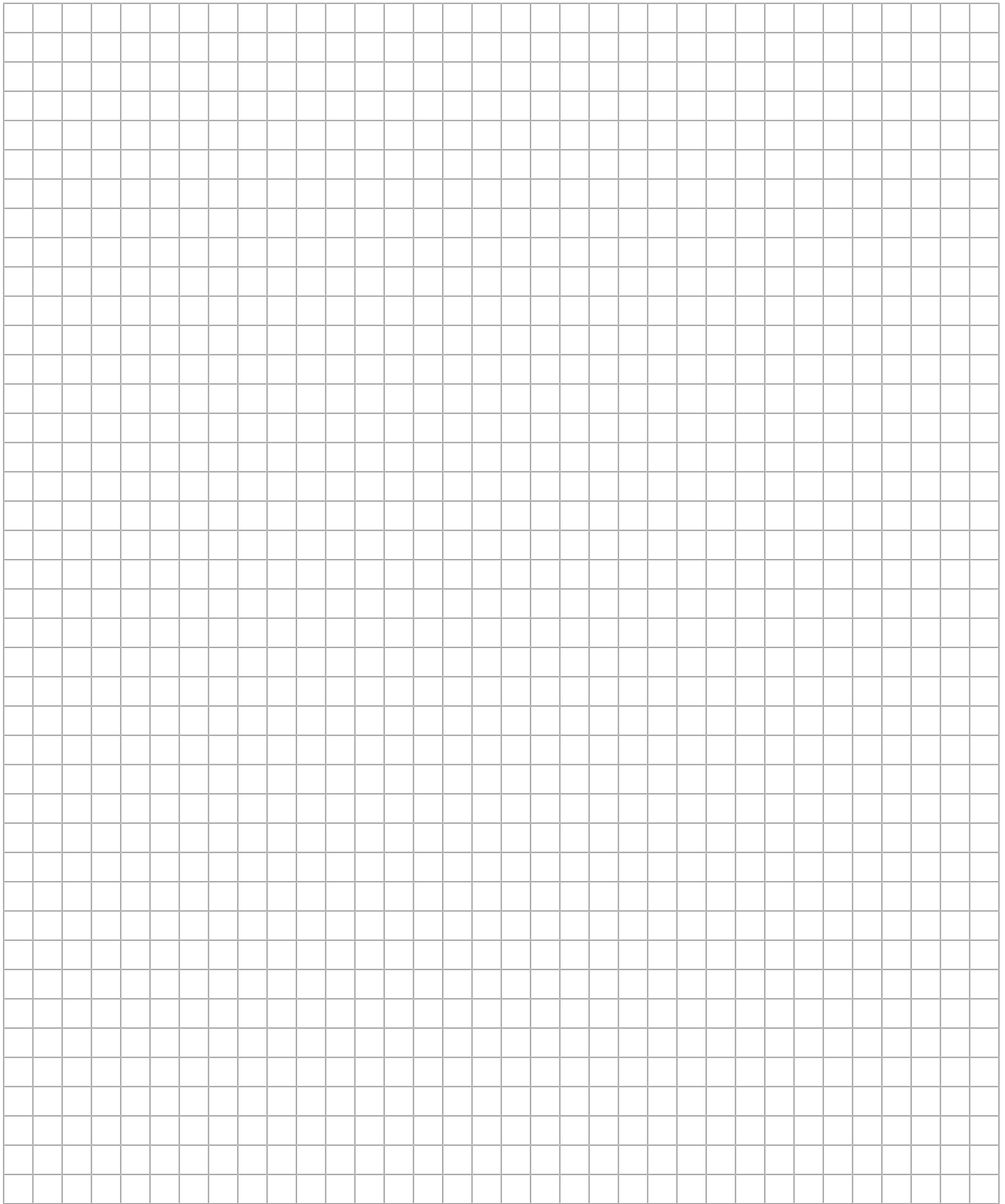



SEW-EURODRIVE
Driving the world

SEW
EURODRIVE

SEW-EURODRIVE GmbH & Co KG
Ernst-Blickle-Str. 42
76646 BRUCHSAL
GERMANY
Tel. +49 7251 75-0
Fax +49 7251 75-1970
sew@sew-eurodrive.com
→ www.sew-eurodrive.com