

SCALING TRADITIONAL CCAP TO MEET THE CAPACITY NEEDS OF THE NEXT DECADE

ACHIEVING A 10X INCREASE IN SERVICE GROUPS
PER HEADEND WITHIN TODAY'S EXISTING
FOOTPRINT

JOHN ULM, ENGINEERING FELLOW

TOM CLOONAN, CTO, NETWORK SOLUTIONS



TABLE OF CONTENTS

- INTRODUCTION 3
- MSO CONCERNS WITH TRADITIONAL CCAP 3
 - Head End Space & Power 3
 - Capacity Limitations due to AM Optics..... 3
- BENEFITS FROM TODAY’S CCAP, A CCAP CASE STUDY 4
 - Chassis & Power Reductions..... 5
 - Rack Space Savings 5
 - Interconnection Savings 6
 - CCAP Case Study Conclusion 6
- TODAY’S CCAP + OPTICS SAVINGS 8
 - Scaling CCAP to CY2020 8
 - Silicon Scaling 9
 - Digital Backplane Scaling 10
 - RF Connector Scaling 10
 - Ethernet Connector/Interface Scaling 11
 - Potential Head End Power and Space Issues 11
- OPTICAL SHELF RACK DENSITIES..... 11
- SCALING HEADENDS TO CY2020..... 12
 - How Many More Node Splits will there be?..... 13
- AM OPTIC CONSIDERATIONS..... 14
 - AM Optics – Distances and Wavelengths 14
 - AM Optics and DOCSIS 3.1 Capacity 16
- CONCLUSION 17
- ACKNOWLEDGEMENTS 18

INTRODUCTION

Much recent industry discussion has focused on new distributed architectures such as Remote PHY and Remote CCAP. Their claims have been that traditional head end based CCAP systems can't scale to meet the space and power requirements for fiber deep architectures needing many node splits; and they can't support modulation rates to take full advantage of DOCSIS 3.1. Is this really true? The purpose of this paper is take a very detailed look at traditional CCAP systems and see how they may adapt to head ends with significant growth in Service Groups (SG).

We start by reviewing the current state of head ends and the impact of installing today's first generation CCAP platform. Topics discussed will include space, power, RF combining and Ethernet interconnection issues. From here, we investigate anticipated improvements we can expect to see in CCAP technology over the coming years. This analysis includes insights from Koomey's Law and Dennard's Scaling Law, lesser known cousins to Moore's Law.

We also take a look at AM Optic technology and the implications of pushing fiber deeper. As SGs get smaller with each successive node split, there is a double whammy of reduced capacity gains and increased costs. How deep should operators push fiber before reaching the point of diminishing returns?

As we pull together all of this information, the results may surprise some operators as to the longevity of traditional CCAP solutions in today's head end. Don't be fooled so quickly by shiny new objects.

MSO CONCERNS WITH TRADITIONAL CCAP

Head End Space & Power

With the continued 50% growth rates in capacities as shown in [CLOONAN1], some operators are concerned that they may need to continue to split nodes until they reach N+0 systems and need a dozen or more times the number of Service Groups (SG) than they have today. There is a fear among some that traditional CCAP boxes will not keep pace with this growth in SG. This could result in operators running out of both space and power in their existing head end facilities. We will show in this paper that this fear may not be well-founded.

Capacity Limitations due to AM Optics

Today's classic HFC network sends broadband signals down the fiber portion using analog based AM optics. Nonlinear Optical noise distorts QAM signals as they propagate over this fiber portion of the HFC plant. The Nonlinear Optical noise increases with longer fiber runs and more

WDM lambdas per fiber. But longer distances and more wavelengths are two trends that are likely to occur with more node-splits and head end consolidations in the future.

Nonlinear Optical noise can significantly decrease SNRs and limit supported QAM modulation rates. This becomes more important with the introduction of DOCSIS 3.1 that requires downstream support up to 4096-QAM, with optional support for 16384-QAM modulation.

While one approach to solve the Nonlinear Optical noise issue is using Distributed Access Architectures (DAA), our paper will discuss some improvements that are occurring in traditional AM optics to address these trends as well.

Even with these improvements in AM optics, there may be some use cases where a digital fiber link is desired (e.g. extreme distances &/or wavelengths). As discussed in [EMMEN], operators have a choice to either go with DAA, or they can add the digital fiber capabilities to their traditional CCAP head end systems. This approach is called Broadband Compression Forward, or BCF for short.

BCF gives the operator all of the digital optic benefits as any DAA approach such as Remote PHY. These benefits include:

- Longer Fiber reaches
- More Lambdas
- Higher SNRs, higher order QAM
- Smaller components, lower power
- “Set it & Forget it” operation

BENEFITS FROM TODAY’S CCAP, A CCAP CASE STUDY

A detailed analysis of the space and power benefits for using CCAP today was given in [ULM]. It showed that CCAP delivers on the promise of many benefits, including:

- Frees Rack Space
- Reduces head end power
- Less Network + RF Interconnections
- Fewer Boxes to Manage

The case study looked at a range of head ends from different operators: from moderate sized suburban hubs to massive urban master head ends; and from integrated CMTS to modular CMTS systems. In addition to these sites, another Urban Hub site that was “bursting at the seams” was also selected.

Chassis & Power Reductions

The case study shows that there is a significant reduction in the number of unique chassis in the system. This benefit is seen across all types of head ends and ranges from 80% to 95% reduction in the total number of devices in the head end. This provides operational savings as well.

The power savings from the reduced chassis are also dramatic with the larger head ends savings 50% to 63% of their CMTS + EQAM power. In addition to total power, the power per DS channel is also reduced by a factor of ten while supporting four times the narrowcast capacity.

Rack Space Savings

For most of the head ends in the case study, the CMTS equipment accounted for the bulk of the equipment rack space. For one site older EQAMs were more significant in an M-CMTS site. For four of the five head ends in the case study, equipment space savings ranged from 60% to 68%.

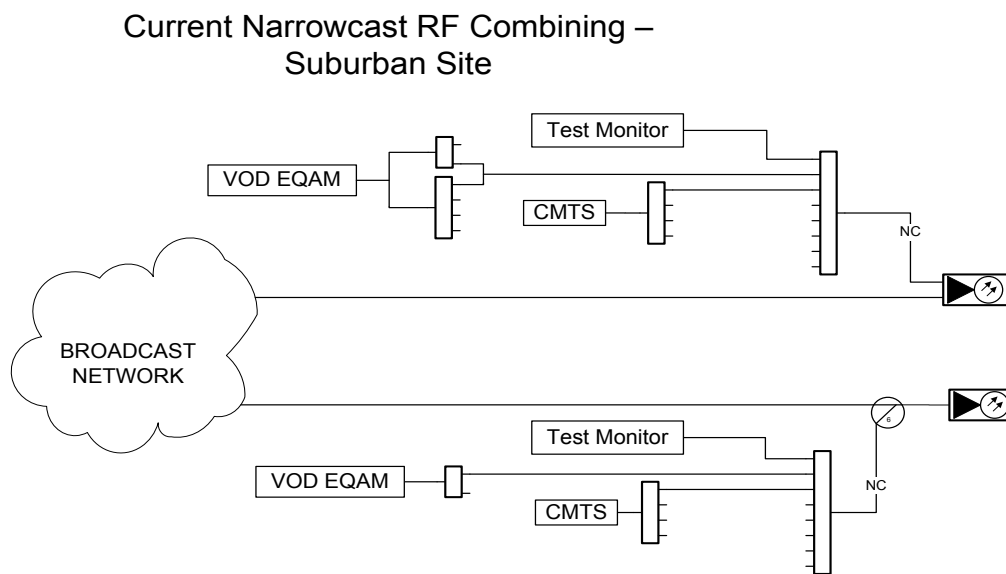

Figure 1a – RF Combining Example: Existing

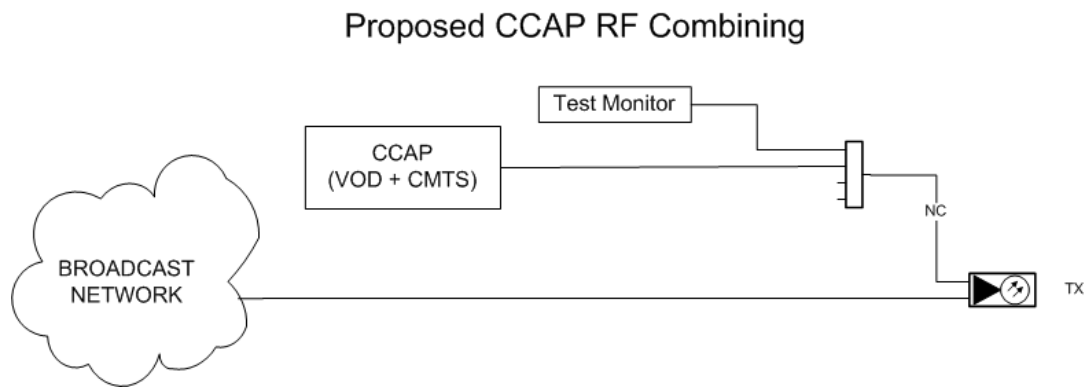

Figure 1b – RF Combining Example: After CCAP Migration

Many of these space savings were then matched with space savings from simplified RF combining. For the case study, a head end design team performed a detailed analysis for collapsing the RF combining with CCAP.

Figure 1a shows the existing RF combining design for one of the suburban hubs, followed by the CCAP design in Figure 1b. Notice that the CCAP design is still a fairly conservative design as a four way combiner was left in the CCAP path to allow for test monitoring with two spare inputs. This means that the case study numbers could be improved even further if needed.

Interestingly, one urban site saw most of its space gains from equipment reduction while the other head ends saw a more equal savings from equipment and RF combining. So in general, the RF combining savings is an equally important point to the CCAP migration. The total space savings seen at both urban master head ends, results in a dozen racks being recovered.

Interconnection Savings

There is more to the CCAP space savings story than just the savings from reduced equipment chassis. There is also a significant savings from the simplified RF Combining that comes with a “Wire Once” strategy.

The “Wire Once” strategy provides significant rack savings from simplified RF combining and makes SG splits to be operationally simpler. The case study shows that RF interconnections are reduced by about 50%.

The study shows even larger gains in the Ethernet port with reductions on the order of 80%. All of this leads to simpler operations and maintenance of the head end.

CCAP Case Study Conclusion

The CCAP case study created some before and after rack elevations to visualize the space savings from installing CCAP. This is shown in Figure 2.

The case study showed that the SG “multiplier” factor ranged from 3.7X to 5.1X. This indicates roughly the number of SG that could be fit within the existing footprint using today’s CCAP technology. The study found that the net effect of the combined equipment and RF Combing space savings is that operators can now roughly quadruple their SG count within their existing footprint.

In addition to quadrupling the SG count, 1st generation CCAP devices will also quadruple the narrowcast channel capacity for every SG. This means that today’s CCAP can enable a 16-fold increase in narrowcast capacity within existing head end footprints.

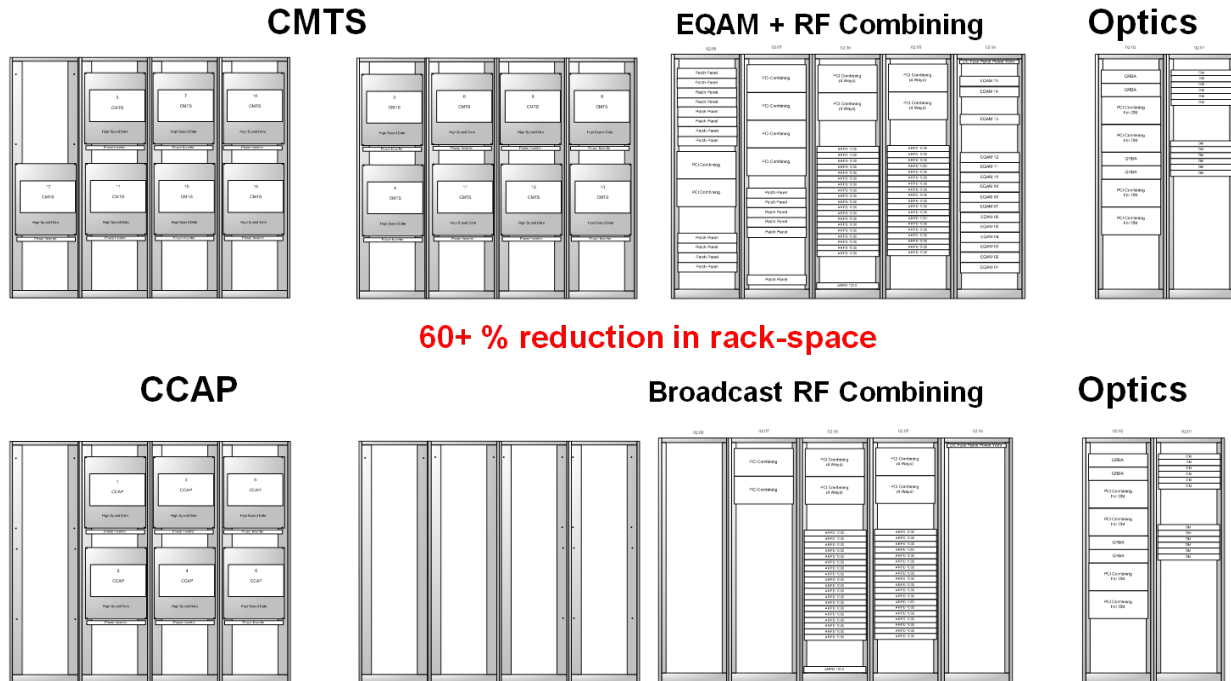

Figure 2 – CCAP Space Savings Example

Configuration	Space Needed For ~200 SG	SG per 1 Rack	Relative Scale
2012 Head End – CMTS, EQAM, RF Combing, Optics	~10 Racks	~20 SG	1X
2013 Traditional CCAP (56 SG) + Optics Shelf (60 SG per 12 RU)	~3 Racks	~70 SG	3.5X

Table 1 – CCAP Space Savings Example, Today’s CCAP

TODAY'S CCAP + OPTICS SAVINGS

The case study had certain limitations. First, it only considered the integration of narrowcast channels into the CCAP system. The broadcast channels were left external to the CCAP box and provide potential for further space savings in the future.

Also, the case study focused on just CMTS, EQAM, and RF combining, but did not delve into the optics components. For this paper we used the case study as a starting point and evaluated the entire head end footprint. While there are significant variations between head ends, we focused on a conservative “normalized” head end footprint that is represented in Table 1. Our model head end requires 10 racks of space today to support about 200 Service Groups (SG). That's an average of 20 SG per rack. This is shown in row 1 of the Table and is our baseline for our analysis.

Our next step is the migration to today's CCAP platforms and existing optic shelf technology. This could squeeze 200 SG into 3 total racks. This uses 56 SG per CCAP based on 2013 availability and optic rack density of 60 SG per 12RU. That results in an average of 70 SG per rack which results in a 3.5X improvement over our baseline configuration. This means that we might fit 700 SG into the existing 10 rack footprint. This is shown in row 2 of the Table.

While this is a great start, will this be sufficient as we go into the next decade? What if an operator needs to scale SG by a factor of a dozen? We'll now take a deeper look into how CCAP and Optics in the head end might scale over time to see what might be achieved by the year 2020.

Scaling CCAP to CY2020

MSOs will undoubtedly experience profound bandwidth growth in most of their service types, including DOCSIS HSD, IP Video, SDV, VoD, nDVR, and Digital Broadcast Video (SD, HD, 4K, and 8K resolutions). But with intelligent planning and carefully-phased deployments of equipment designed to support this growth, MSOs should be able to ride on their HFC infrastructure deep into the 2020 decade and potentially into the 2030 decade. If MSOs select certain paths for their equipment evolution; CCAPs may also provide a very smooth and cost-effective transition from the HFC infrastructure that exists today to the FTTH infrastructure that will likely be used by many MSOs by the 2040-2050 timeframe.

We will now look into some forward-looking ideas on how to accommodate the expected growth rates of the future and present some potential ideas on how CCAPs may evolve in the future. Since these ideas are forward-looking in nature, they should be viewed as proposals that may be altered down the road.

Our analysis will take a detailed look at many aspects that go into the SG density of a CCAP chassis. Scaling issues considered include silicon, backplane, RF connector and Ethernet

connector technologies. And just as important, a close look is done at the projected power consumption over time.

Silicon Scaling

Moore's Law is an interesting empirical observation that has held true for 40 years, implying that the number of transistors in chips will double every 2 years (i.e. grow by a "change factor" of 1.42 every year). Over a 7 year time span from 2013 to 2020, this would result in a growth of:

$$\text{Moore's Law: } (1.42x)^7 = 11.6x$$

However, Moore's Law does NOT consider transistor speeds or power consumption, so it really does not give any clues as to the trends in processing capacity or power consumption for chips.

Koomey's Law is another (less famous, but more useful) empirical observation implying that for computing hardware in silicon, the number of computations per Joule of energy will double every 1.57 years (i.e. grow by a "change factor" of 1.56 every year)

If we assume that CCAPs will have fixed power per chassis between 2013 and 2020, then application of Koomey's Law to CCAP systems over the next 7 years predicts that the CCAP silicon processing capacity should grow from its current processing capacity level to:

$$\text{Koomey's Law: } (1.56x)^7 = 22.5x$$

Interesting, but this was for processors, so let's check those results by looking at it another way, by using Dennard's Scaling Law.

Dennard's Scaling Law is more useful in predicting trends in chip processing capacity and power consumption... and it can also be used to predict more complex behaviors like the trends in chip processing capacity when constrained by specific power consumption limits.

Application of Dennard's Scaling Law can be used to show that for computing hardware in typical silicon systems, the number of computations per Joule of energy will grow by a "change factor" of 1.37x every year.

Assuming that CCAPs will have fixed power per chassis between 2013 and 2020, then application of Dennard's Scaling Law to CCAP systems over the next 7 years predicts that the CCAP silicon processing capacity should grow from its current processing capacity level to:

$$\text{Dennard's Law: } (1.37x)^7 = 9.1x$$

This is a bit more conservative than Koomey's Law and gives ourselves a large amount of head-room.

Does this Processing Growth match reality? Consider the evolution for an example commercially available Multi-Core Processor family:

- 2009: 16 cores
- 2011: 32 cores
- 2013: 48-72 cores
- 2014: 128 cores
- 2015: 144 cores

Note that they had 9x increase in 6 years or an 1.44x Annual Change Factor (which is quite similar to the 1.37x number from Dennard's Law). This would lead to a 7 year growth of:

$$\text{Multi-core NPU example: } (1.44x)^7 = 13.0x$$

Based on all this, it looks reasonable to assume that the silicon processing on a CCAP card will grow by at least 8-10x by the year 2020:

$$\text{CCAP Processor Scaling} = 8\text{-}10x$$

Digital Backplane Scaling

In 2013, typical CCAP backplanes support KR interfaces operating at 10-20 Gbps between each Switch Fabric Card and each Client Card (2.5 Gbps per lane).

By 2015, typical CCAP backplanes will likely support KR4 interfaces operating at 40-80 Gbps between each Switch Fabric Card and each Client Card (10 Gbps per lane).

Current R&D being carried out has 33 Gbps per lane being transmitted across typical backplanes...

So, by 2020, this should easily permit CCAP backplanes to support interfaces operating at 100 Gbps+ between each Switch Fabric Card and each Client Card (25 Gbps per lane). This is 10x the backplane speeds of today:

$$\text{CCAP Backplane Scaling} = \sim 10x$$

RF Connector Scaling

24 MCX connectors are easily positioned on the CCAP faceplates today for upstream cards. It is believed that the use of MMCX connectors could increase the density of MCX connectors by a factor of ~1.4 and could increase the density of F-connectors by a factor of ~4. As a result, 32 connectors per face plate will likely be possible.

When combined with other techniques such as frequency stacking, it may be possible to create the equivalent of 32-64 connectors per card in the future. Since typical Downstream CCAP cards have ~8 connectors per card today. This results in a 4x to 8x increase in Downstream card connectors. Since typical Upstream CCAP cards have ~24 connectors per card today. This results in only a 1.3x to 2.6x increase in Upstream card connectors. However, the upstream spectrum is

significantly less than the downstream spectrum, so frequency stacking can be used more aggressively on upstream connectors to keep pace if needed.

CCAP RF Connector Scaling = 4-8x

Ethernet Connector/Interface Scaling

For our Ethernet interconnections analysis, an example CCAP chassis is used that is constructed from a “typical” ATCA chassis. An ATCA chassis has a card faceplate with dimensions of ~13.5” x 1.2”. Twelve SFP+ connectors (i.e. 12 x 10 Gbps) are easily positioned on these faceplates today. Eight CFP4 connectors (i.e. 8 x 100 Gbps) will be easily positioned on these faceplates by 2020.

The use of both front and back faceplates can double that density to be 16 CFP4 connectors per card (1.6 Tbps). Thus, the total increase results in a 13x increase in Ethernet interface bandwidth:

CCAP Ethernet NSI Scaling = 13x

Potential Head End Power and Space Issues

From the analyses in the previous sections, it can be seen that great improvements will be seen in silicon performance levels, backplane performance levels, Ethernet performance levels, and connector performance levels between now and 2020. Taken as a whole, the most limiting factor will likely be found in the RF connector densities, which may provide only a 4-8x improvement in RF connector density between now and 2020.

As a result, MSOs can likely expect to see at least four times the number of RF ports on their CCAP chassis in 2020 time-frame than they do today (without experiencing any significant increases in chassis sizes or chassis power levels). This should permit typical CCAP chassis of the 2020 time-frame to support 200 Service Groups or more per CCAP chassis.

However, the CCAP is only part of the head end solution. We also need to look closely at the Optical Shelf and see how that will scale over time.

OPTICAL SHELF RACK DENSITIES

The CCAP case study did not factor into its analysis the impact of optic shelf rack densities. As CCAP densities increase and the RF Combining is eliminated, then the optic shelves start to become the limiting factor for head end space requirements.

Figure 3 takes a closer look at some example rack densities from multiple vendors. This shows the rack space required to support 80 SG with a 1:1 ratio for upstream and downstream optics. This represents several generations of optics and it is apparent that there could be almost a three to one difference in optical rack density depending on vendor.

The optic solution on the left side of the figure represents the latest state of the art for the year 2014. It squeezes 80 SG of optics into 12RU. Currently, the upstream optical receivers are twice as dense as the downstream optical transmitters.

Down the road, once the optical TX catches up to the optical RX, we might see optical rack densities of 80 SG in 8RU. This is the number that we'll use for our year 2020 analysis. We feel this is very conservative and feasible in this time frame. Longer term we may actually see a trend towards integrating multiple WDM wavelengths into optical components which could yield another 2X or 4X in optical shelf rack densities.

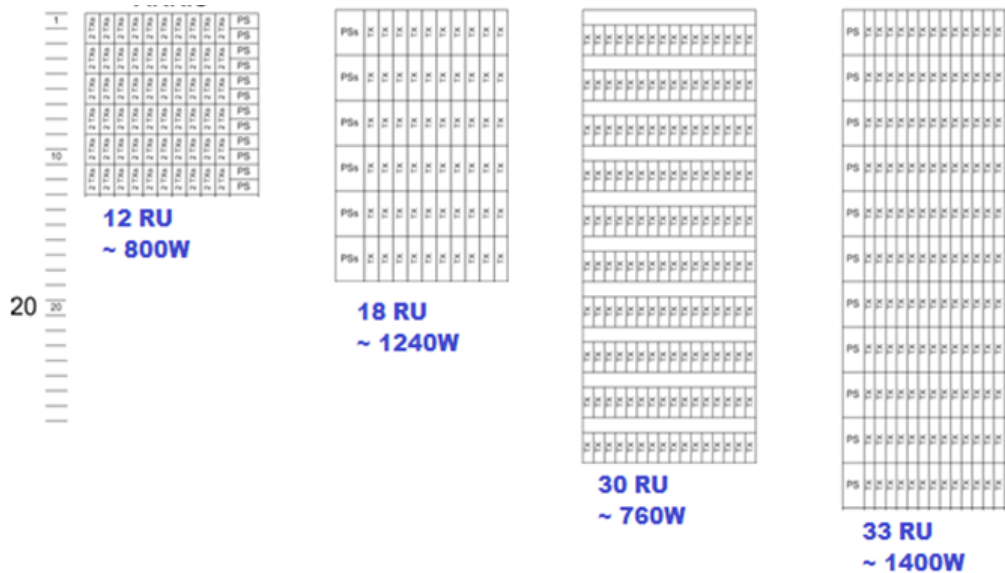

Figure 3 – Example Optic Shelves Rack Densities for 80 SG

An alternate path for future optics might be integration of pluggable optics directly into the CCAP chassis. This may be reasonable in some scenarios, but there are a myriad of trade-offs that must be considered. Today's external Optical Shelves offer the full range of TX & RX optics necessary to cover the many different HFC plant conditions encountered today. It is also expected that external Optical Shelves can provide advantages as operators look to integrate WDM capabilities as well.

SCALING HEADENDS TO CY2020

Now let's put together all this information that we've gathered. As the next step in the CCAP evolution, we'll assume that the 2nd generation CCAP devices can achieve at least 25% increase in SG density. This should be quite reasonable given our previous analysis and pushes the CCAP up to ~70 SG per chassis.

At the same time, we've seen optic shelf rack density increase in the last year from 60 SG per 12RU up to 80 SG per 12RU.

Using these two inputs, the next step in the CCAP evolution should get us down to 2 racks to support 200 SG. That's an average of 100 SG per rack for a 5X increase over our baseline of today's CMTS/EQAM based head ends. This is shown in the third row of Table 2 below.

As we push towards the end of this decade, our previous analysis shows that traditional CCAP systems can just about quadruple densities of today's CCAP by CY2020. That would put us around 200 SG per CCAP chassis. This then combines with the expected continued advances in optical shelf rack densities to 80 SG per 8RU. The result is that we have a clear line of sight to achieving 200 SG in a single rack within this decade. That provides a 10X increase in SG growth within today's existing head end footprint. See the last row in Table 2.

In addition to this SG growth, DOCSIS 3.1 will also give a giant boost to the SG capacity. Starting from today's CCAP system that provides about 1 Gbps (i.e. 32 DOCSIS channels), DOCSIS 3.1 can provide more than 10 Gbps per SG.

Configuration	Space Needed For ~200 SG	SG per 1 Rack	Relative Scale
2012 Head End – CMTS, EQAM, RF Combining, Optics	~10 Racks	~20 SG	1X
2013 Traditional CCAP (56 SG) + Optics Shelf (60 SG per 12RU)	~3 Racks	~70 SG	3.5X
2nd Gen CCAP (~70 SG) + 2014 Optics Shelf (80 SG per 12RU)	~2 Racks	~100 SG	5X
Future 2020 CCAP (~200 SG) + Optics Shelf (120 SG per 12RU)	~1 Rack	~200 SG	10X

Table 2 – CCAP Space Savings Example, Future CCAP

How Many More Node Splits will there be?

Eventually operators will reach a point where it no longer makes sense to split a node further. As discussed further in [CLOONAN2], a fundamental transition is occurring in cable system traffic engineering. Previously with extremely large SG, average traffic load dominated the analysis and splitting nodes would cut the average traffic roughly in half. However with today's Downstream Service Group sizes around 500 subs, the max burst traffic rate, Tmax, plays a

significant role. Some people now use a rule of thumb of taking 2x or 3x the T_{max} rate of the highest service tier to determine the amount of DOCSIS capacity needed.

As operators continue to split nodes past this point, the SG size becomes so small that average traffic load is in the noise and the T_{max} burst rate dominates the traffic engineering. This means that further node splits will provide diminishing returns. It will become more important to increase burst capacity through DOCSIS 3.1 introduction with plant upgrades to 1.2GHz.

Thus, for most MSOs who will perform no more than 3-4 rounds of node-splits within the next decade or two, it is clear that the traditional head-end-based CCAP chassis of the future will be able to accommodate their needs. With a 10x SG increase, future CCAP might take today's 500 sub per SG down to an average of 50 subs per SG. The CCAP chassis of the future will provide increases in RF port (Service Group) densities that can keep up with the demand created by the node splits.

AM OPTIC CONSIDERATIONS

As discussed at the beginning of the paper, the other major concern making operators think about migrating down the DAA path is the impact Nonlinear Optical noise on the potential capacity gains from DOCSIS 3.1.

Nonlinear Optical noise can significantly decrease SNRs and limit supported QAM modulation rates. This becomes more important with the introduction of DOCSIS 3.1 that requires downstream support up to 4096-QAM, with optional support for 16384-QAM modulation.

AM Optics – Distances and Wavelengths

In recent years, there continues to be significant improvements that are occurring in traditional AM optics to address the issue of Nonlinear Optical noise. This means that the latest generation of optics can support longer reach capability as shown in Figure 4, where the red represents recent optic improvements.

Newer AM optics also supports more lambdas, such as 44 wavelengths. That's almost a factor of three improvements over previous generation optics. Figure 5 shows an example of the trade-off between # of wavelengths and distances. Note that 44 wavelengths can still be achieved at 40km distances. Only longer distances results in a reduction in wavelengths supported.

It is also important to note that these devices are full 1.2GHz spectrum products that can take full advantage of DOCSIS 3.1. There is a reduction in power too which is important for scaling the head end SG capacity.

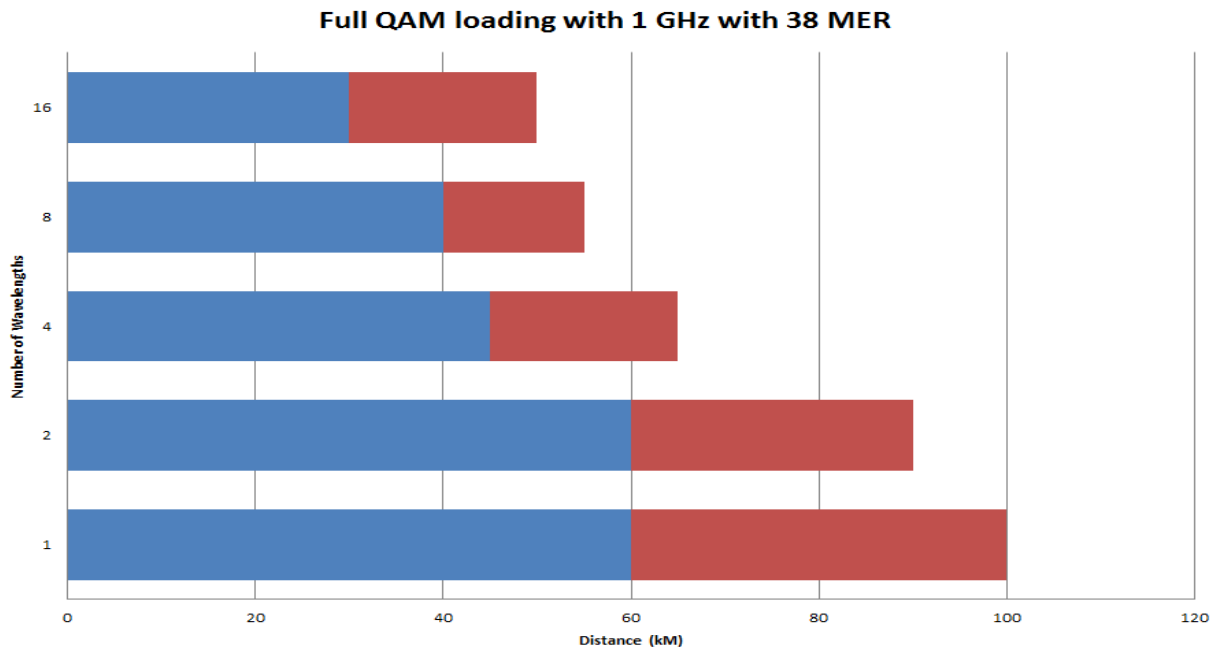

Figure 4 – CY2014 AM Optic Distance Improvements

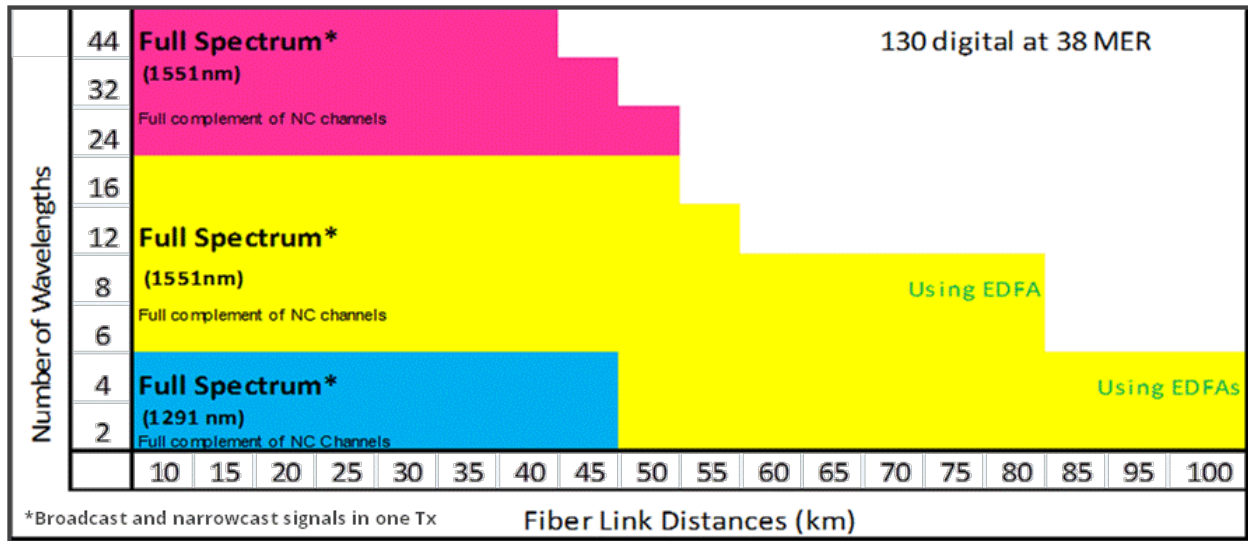

Figure 5 – CY2014 AM Optic Capabilities: Wavelength vs. Distance

AM Optics and DOCSIS 3.1 Capacity

So, a major question for AM optics becomes what kind of capacity can be achieved with DOCSIS 3.1? This topic is investigated in detail in [EMMEN]. A very informative chart from that paper is shown in Figure 6. The chart provides the PHY capacities for various optic configurations, both AM optics and digital optics (e.g. Ethernet).

The first four bars in the chart are various AM optic configurations. The first four bars represents Full Spectrum AM optics at distances of 80km, 40km, 25km and 10km respectively. The last two bars on the chart represent different types of digital fiber systems. Note that “Remote Gadgets” refers to either Remote PHY or Remote CCAP.

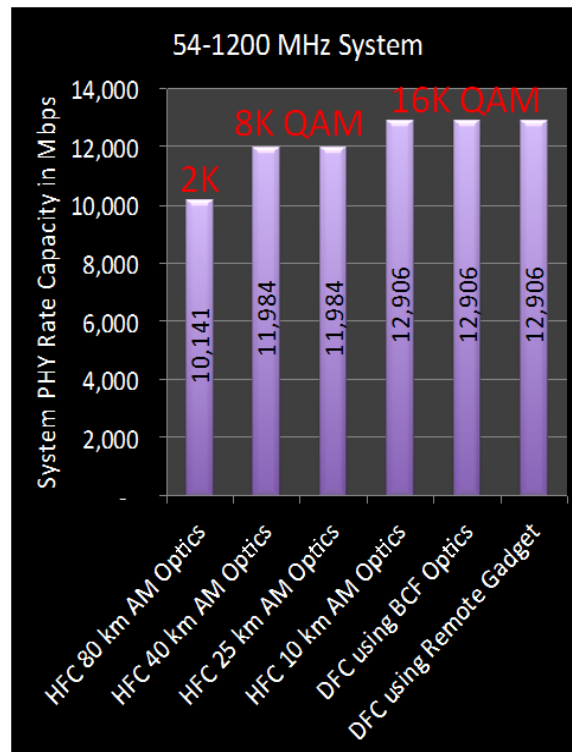

Figure 6 – PHY Capacity for Various Optic Configurations

As can be seen in Figure 6, the digital fiber systems provide maximum DOCSIS 3.1 capacity. The value of 12,906 Mbps represents full spectrum OFDM channels operating at 16384-QAM modulation. Note that AM optics at 10km also achieves the theoretical maximum as well.

The AM optic capacities start to drop off as the distance increases. The capacity at 25km and 40km corresponds to 8192-QAM modulation. It should be noted that 4096-QAM is the highest mandatory modulation for DOCSIS 3.1 and is what initial products will

support. 8192-QAM and 16384-QAM are future options and it is not clear when or if they may be deployed.

At 80km distances, the AM optics capacity drops to 2048-QAM. An interesting note is that the total PHY capacity at this distance is still just over 10 Gbps. This means that it can still match cable plant capacity with a Remote Gadget being fed (and limited by) a 10G Ethernet link.

We now take a look at these results in a tabular form in Table 3. For the relative gain, we use 40km AM optics as the baseline performance for comparison purposes.

As the table shows, 40km AM optics supports more than the full DOCSIS 3.1 mandatory requirements of 4096-QAM. Even once the optional modulations are introduced, 1638-QAM will only provide operators with a best case gain of 7.5% over the 40km AM Optic baseline. These modulations will also have increased SNR requirements which might require more robust FEC that could eat into that gain. Similarly, operating AM optics at 80km only results in a 15% hit compared to the baseline, but only an 8% hit to total PHY capacity compared to the D3.1 mandatory maximum modulation of 4096-QAM.

Technology	D3.1 QAM Modulation	Relative Gain
Digital Optics	16,384-QAM	+7.5%
AM Optics, 10km	16,384-QAM	+7.5%
AM Optics, 25km	8192-QAM	0
AM Optics, 40km	8192-QAM	0
AM Optics, 80km	2048-QAM	-15%

Table 3 – PHY Capacity for Various Optic Configurations

CONCLUSION

Traditional head-end-based CCAP and AM Optic systems will capitalize on many improvements in silicon, packaging, interconnection, and cooling technologies over the next 10 to 15 years. Our estimated gains based on well-known Moore's Law and lesser known cousins Koomey's Law and Dennard's Law, show that these improvements will permit extensive increases in bandwidth per RF port (permitting >10 Gbps per RF port) and will also permit extensive increases in the number of RF ports (e.g. allowing more than 200 Downstream RF ports per CCAP chassis) by the end of this decade.

Over the next 4-6 years, DOCSIS 3.1 will also enable a 10x increase in capacity per SG from today's ~1 Gbps HSD (e.g. 24-32 DOCSIS 3.0 channels) to 10+ Gbps (e.g. 5 or 6 192 MHz OFDM channels). The paper shows that AM optic technology advances will allow

operators to still take advantage of this, supporting 40km distances with 44 wavelengths at DOCSIS 3.1 4096-QAM modulation rates.

So, the bottom line is that traditional head end systems can leverage CCAP + optic advances to get both a 10X increase in SG counts in conjunction with 10X increase in capacity per SG before the end of this decade. Those increases should permit traditional head-end-based CCAPs to provide more than enough bandwidth capacity and RF port capacity than most MSOs will require as they perform expected node splits in the coming 10 to 20 years.

ACKNOWLEDGEMENTS

The authors would like to thank Mike Emmendorfer for his assistance in helping to pull together material for this paper and for his review of the paper.

MEET ONE OF OUR EXPERTS: John Ulm

John Ulm's position is an Engineering Fellow, Broadband Systems within the ARRIS Network Solutions CTO group. In this role he's been investigating Advanced Technologies for Broadband Systems. This includes strategic technical directions for multiscreen services and bandwidth expansion. Recent activities include research into Multi-screen IP Video solutions; next generation CCAP architectures; HFC distributed access architectures such as Remote CCAP and Remote PHY; and new HFC protocols including DOCSIS 3.1 and IEEE 802.3bn EPoC.

John's two+ decades in the Broadband industry began as designer, architect, and MAC protocol developer at LANcity, pioneering the industry's first cable modem systems. He was a primary author for the Cable Industry's DOCSIS 1.0 and 1.1 specifications that drove early cable modem success. He also spent time as a Network Processor architect for Nortel and as a senior technical consultant to the Broadband industry with YAS Corp. John holds a BSEE and MSEE from RPI and has a multitude of papers and patents to his name.

REFERENCES

[CLOONAN1] – “HFC Spectrum Planning in the Era of the HSD Bandwidth Explosion”; T. Cloonan Ph.D., S. Chernak, SCTE Cable-Tec Expo 2012

[ULM] – “CCAP Case Study: Enabling Converged Video + Data thru Space & Power Savings”; J. Ulm, J. Finkelstein, S. Rahman, J. Salinger, The Cable Show Spring Technical Forum 2013

[CLOONAN2] – “Predictions on the Evolution of Access Networks to the Year 2020 & Beyond”; T. Cloonan Ph.D., M. Emmendorfer, J. Ulm, A. Al-Banna Ph.D., The Cable Show Spring Technical Forum 2014

[EMMEN] – “A Side-by-side Comparison of Centralized vs. Distributed Access Architectures”; M. Emmendorfer, T. Cloonan Ph.D., J. Ulm, The Cable Show Spring Technical Forum 2014

©ARRIS Enterprises, Inc. 2014 All rights reserved. No part of this publication may be reproduced in any form or by any means or used to make any derivative work (such as translation, transformation, or adaptation) without written permission from ARRIS Enterprises, Inc. (“ARRIS”). ARRIS reserves the right to revise this publication and to make changes in content from time to time without obligation on the part of ARRIS to provide notification of such revision or change.