

# **DIGITAL MULTIFUNCTIONAL SYSTEM MX-B467F**

---

## **User's Guide**

**November 2020**

---

Machine type(s):

7017

Models:

679 and its equivalent models

# Contents

- Safety information..... 6**
  - Conventions..... 6
  - Product statements..... 6
  
- Learning about the printer..... 9**
  - Selecting a location for the printer..... 9
  - Printer configurations..... 10
  - Attaching cables..... 11
  - Using the control panel..... 13
  - Understanding the status of the power button and indicator light..... 13
  - Using the home screen..... 14
  - Printing the Menu Settings Page..... 14
  - Printing the Network Setup Page..... 15
  
- Setting up and using the home screen applications..... 16**
  - Customizing the home screen..... 16
  - Setting up Card Copy..... 16
  - Using Shortcut Center..... 16
  - Using Display Customization..... 17
  - Setting up Scan Center..... 17
  - Managing contacts..... 18
  
- Loading paper and specialty media..... 20**
  - Setting the paper size and type..... 20
  - Configuring Universal paper settings..... 20
  - Loading trays..... 20
  - Loading the multipurpose feeder..... 22
  - Linking trays..... 23
  
- Supported paper..... 24**
  - Supported paper sizes..... 24
  - Supported paper types..... 26
  - Supported paper weights..... 27

**Printing.....28**

- Printing from a computer.....28
- Printing from a mobile device..... 28
- Printing from a flash drive..... 29
- Supported flash drives and file types..... 30
- Configuring confidential jobs..... 31
- Printing confidential and other held jobs.....31
- Printing a font sample list..... 32
- Canceling a print job..... 32

**Copying..... 33**

- Making copies..... 33
- Copying photos..... 33
- Copying on letterhead..... 33
- Copying on both sides of the paper (two-sided)..... 33
- Reducing or enlarging copies..... 34
- Collating copies..... 34
- Placing separator sheets between copies..... 34
- Copying multiple pages onto a single sheet..... 34
- Creating a copy shortcut..... 34

**E-mailing..... 35**

- Configuring the e-mail server settings..... 35
- Sending an e-mail.....35
- Creating an e-mail shortcut..... 36

**Faxing..... 37**

- Setting up the printer to fax..... 37
- Sending a fax..... 43
- Scheduling a fax..... 44
- Creating a fax destination shortcut..... 44
- Changing the fax resolution..... 44
- Adjusting the fax darkness..... 44
- Printing a fax log..... 45
- Blocking junk faxes..... 45
- Holding faxes..... 45

Forwarding a fax..... 45

**Scanning..... 46**

Scanning to a computer..... 46

Creating an FTP shortcut..... 46

Scanning to an FTP server..... 47

Scanning to a flash drive..... 47

**Understanding the printer menus..... 49**

Menu map..... 49

Device..... 50

Print..... 62

Paper..... 70

Copy..... 73

Fax..... 76

E-mail..... 80

FTP..... 86

Network/Ports..... 90

USB Drive..... 102

Security..... 108

Reports..... 116

Help..... 117

Troubleshooting..... 117

**Securing the printer..... 119**

Locating the security slot..... 119

Erasing printer memory..... 119

Erasing printer hard disk memory..... 119

Encrypting the printer hard disk..... 120

Restoring factory default settings..... 120

Statement of Volatility..... 120

**Maintaining the printer..... 122**

Adjusting the speaker volume..... 122

Networking..... 122

Cleaning printer parts..... 124

Ordering parts and supplies..... 128

Replacing parts and supplies..... 129  
Moving the printer..... 139  
Saving energy and paper..... 140

**Clearing jams..... 142**

Avoiding jams.....142  
Identifying jam locations..... 143  
Paper jam in door A.....144  
Paper jam in the rear door.....148  
Paper jam in the standard bin.....149  
Paper jam in the duplex unit..... 149  
Paper jam in trays..... 150  
Paper jam in the multipurpose feeder.....151  
Paper jam in the automatic document feeder.....152

**Troubleshooting..... 154**

Network connection problems..... 154  
Issues with supplies..... 156  
Paper feed problems..... 156  
Printing problems.....159  
Faxing problems..... 180  
Scanning problems.....183  
Contacting your dealer..... 187

**Upgrading and migrating.....188**

Hardware.....188  
Software..... 200  
Firmware..... 201

**Notices.....203**

**Index..... 214**

# Safety information





## Conventions

**Note:** A *note* identifies information that could help you.







**Warning:** A *warning* identifies something that could damage the product hardware or software.

**CAUTION:** A *caution* indicates a potentially hazardous situation that could injure you.

Different types of caution statements include:

-  **CAUTION—POTENTIAL INJURY:** Indicates a risk of injury.
-  **CAUTION—SHOCK HAZARD:** Indicates a risk of electrical shock.
-  **CAUTION—HOT SURFACE:** Indicates a risk of burn if touched.
-  **CAUTION—TIPPING HAZARD:** Indicates a crush hazard.
-  **CAUTION—PINCH HAZARD:** Indicates a risk of being caught between moving parts.

## Product statements

-  **CAUTION—POTENTIAL INJURY:** To avoid the risk of fire or electrical shock, connect the power cord to an appropriately rated and properly grounded electrical outlet that is near the product and easily accessible.
-  **CAUTION—POTENTIAL INJURY:** To avoid the risk of fire or electrical shock, use only the power cord provided with this product or the manufacturer's authorized replacement.
-  **CAUTION—POTENTIAL INJURY:** Do not use this product with extension cords, multioutlet power strips, multioutlet extenders, or UPS devices. The power capacity of these types of accessories can be easily overloaded by a laser printer and may result in a risk of fire, property damage, or poor printer performance.
-  **CAUTION—POTENTIAL INJURY:** Do not use this product with an inline surge protector. The use of a surge protection device may result in a risk of fire, property damage, or poor printer performance.
-  **CAUTION—POTENTIAL INJURY:** To reduce the risk of fire, use only a 26 AWG or larger telecommunications (RJ-11) cord when connecting this product to the public switched telephone network. For users in Australia, the cord must be approved by the Australian Communications and Media Authority.
-  **CAUTION—SHOCK HAZARD:** To avoid the risk of electrical shock, do not place or use this product near water or wet locations.
-  **CAUTION—SHOCK HAZARD:** To avoid the risk of electrical shock, do not set up this product or make any electrical or cabling connections, such as the power cord, fax feature, or telephone, during a lightning storm.

 **CAUTION—POTENTIAL INJURY:** Do not cut, twist, bind, crush, or place heavy objects on the power cord. Do not subject the power cord to abrasion or stress. Do not pinch the power cord between objects such as furniture and walls. If any of these things happen, a risk of fire or electrical shock results. Inspect the power cord regularly for signs of such problems. Remove the power cord from the electrical outlet before inspecting it.

 **CAUTION—SHOCK HAZARD:** To avoid the risk of electrical shock, make sure that all external connections (such as Ethernet and telephone system connections) are properly installed in their marked plug-in ports.

 **CAUTION—SHOCK HAZARD:** To avoid the risk of electrical shock, if you are accessing the controller board or installing optional hardware or memory devices sometime after setting up the printer, then turn the printer off, and unplug the power cord from the electrical outlet before continuing. If you have any other devices attached to the printer, then turn them off as well, and unplug any cables going into the printer.

 **CAUTION—SHOCK HAZARD:** To avoid the risk of electrical shock, do not use the fax feature during a lightning storm.





 **CAUTION—SHOCK HAZARD:** To avoid the risk of electrical shock when cleaning the exterior of the printer, unplug the power cord from the electrical outlet and disconnect all cables from the printer before proceeding.

 **CAUTION—POTENTIAL INJURY:** If the printer weight is greater than 20 kg (44 lb), then it may require two or more people to lift it safely.

 **CAUTION—POTENTIAL INJURY:** When moving the printer, follow these guidelines to avoid personal injury or printer damage:

- Make sure that all doors and trays are closed.
- Turn off the printer, and then unplug the power cord from the electrical outlet.
- Disconnect all cords and cables from the printer.
- If the printer has separate floor-standing optional trays or output options attached to it, then disconnect them before moving the printer.
- If the printer has a caster base, then carefully roll it to the new location. Use caution when passing over thresholds and breaks in flooring.
- If the printer does not have a caster base but is configured with optional trays or output options, then remove the output options and lift the printer off the trays. Do not try to lift the printer and any options at the same time.
- Always use the handholds on the printer to lift it.
- Any cart used to move the printer must have a surface able to support the full footprint of the printer.
- Any cart used to move the hardware options must have a surface able to support the dimensions of the options.
- Keep the printer in an upright position.
- Avoid severe jarring movements.
- Make sure that your fingers are not under the printer when you set it down.
- Make sure that there is adequate clearance around the printer.

 **CAUTION—TIPPING HAZARD:** Installing one or more options on your printer or MFP may require a caster base, furniture, or other feature to prevent instability causing possible injury. For more information on supported configurations, contact the place where you purchased the printer.

-  **CAUTION—TIPPING HAZARD:** To reduce the risk of equipment instability, load each tray separately. Keep all other trays closed until needed.
-  **CAUTION—HOT SURFACE:** The inside of the printer might be hot. To reduce the risk of injury from a hot component, allow the surface to cool before touching it.
-  **CAUTION—PINCH HAZARD:** To avoid the risk of a pinch injury, use caution in areas marked with this label. Pinch injuries may occur around moving parts, such as gears, doors, trays, and covers.
-  **CAUTION—POTENTIAL INJURY:** This product uses a laser. Use of controls or adjustments or performance of procedures other than those specified in the *User's Guide* may result in hazardous radiation exposure.
-  **CAUTION—POTENTIAL INJURY:** The lithium battery in this product is not intended to be replaced. There is a danger of explosion if a lithium battery is incorrectly replaced. Do not recharge, disassemble, or incinerate a lithium battery. Discard used lithium batteries according to the manufacturer's instructions and local regulations.

This product is designed, tested, and approved to meet strict global safety standards with the use of specific manufacturer's components. The safety features of some parts may not always be obvious. The manufacturer is not responsible for the use of other replacement parts.

Refer service or repairs, other than those described in the user documentation, to a service representative.

This product uses a printing process that heats the print media, and the heat may cause the media to release emissions. You must understand the section in your operating instructions that discusses the guidelines for selecting print media to avoid the possibility of harmful emissions.

This product may produce small amounts of ozone during normal operation, and may be equipped with a filter designed to limit ozone concentrations to levels well below the recommended exposure limits. To avoid high ozone concentration levels during extensive usage, install this product in a well-ventilated area and replace the ozone and exhaust filters if instructed to do so in the product maintenance instructions. If there are no references to filters in the product maintenance instructions, then there are no filters requiring replacement for this product.

**SAVE THESE INSTRUCTIONS.**



# Learning about the printer

## Selecting a location for the printer

- Leave enough room to open trays, covers, and doors and to install hardware options.
- Set up the printer near an electrical outlet.

 **CAUTION—POTENTIAL INJURY:** To avoid the risk of fire or electrical shock, connect the power cord to an appropriately rated and properly grounded electrical outlet that is near the product and easily accessible.

 **CAUTION—SHOCK HAZARD:** To avoid the risk of electrical shock, do not place or use this product near water or wet locations.

- Make sure that airflow in the room meets the latest revision of the ASHRAE 62 standard or the CEN Technical Committee 156 standard.
- Provide a flat, sturdy, and stable surface.
- Keep the printer:
  - Clean, dry, and free of dust
  - Away from stray staples and paper clips
  - Away from the direct airflow of air conditioners, heaters, or ventilators
  - Free from direct sunlight and humidity extremes
- Observe the recommended temperatures and avoid fluctuations.

Ambient temperature	10 to 32°C (50 to 90°F)
Storage temperature	0 to 40°C (32 to 104°F)

- Allow the following recommended amount of space around the printer for proper ventilation:

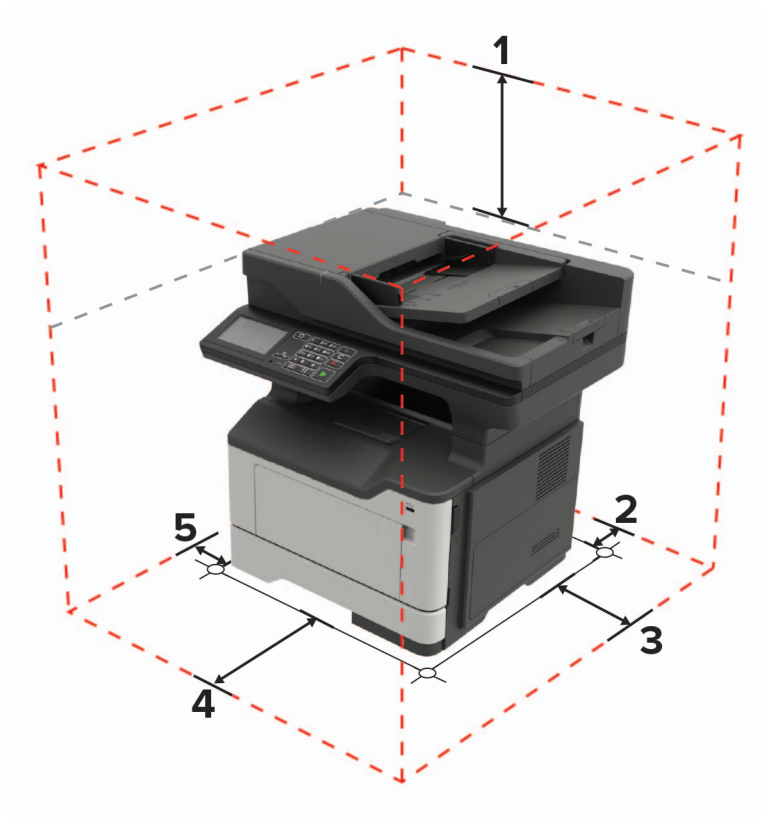

1	Top	737 mm (29 in.)
2	Rear	203 mm (8 in.)
3	Right side	305 mm (12 in.)
4	Front	510 mm (20 in.)
5	Left side	203 mm (8 in.)

## Printer configurations

**CAUTION—TIPPING HAZARD:** Installing one or more options on your printer or MFP may require a caster base, furniture, or other feature to prevent instability causing possible injury. For more information on supported configurations, contact the place where you purchased the printer.

**CAUTION—TIPPING HAZARD:** To reduce the risk of equipment instability, load each tray separately. Keep all other trays closed until needed.

You can configure your printer by adding optional 250- or 550-sheet trays. For more information, see [“Installing optional trays” on page 199](#).

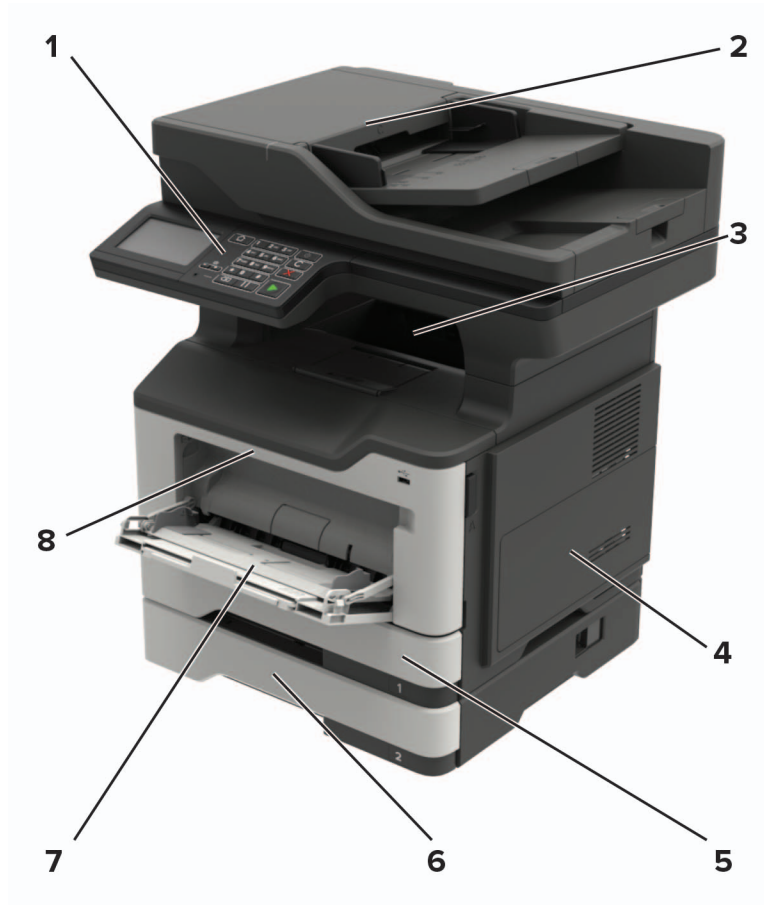

1	Control panel
2	Automatic document feeder (ADF)
3	Standard bin
4	Controller board access cover
5	Standard 250-sheet tray
6	Optional 250- or 550-sheet tray
7	Multipurpose feeder
8	Door A

## Attaching cables

- ⚠ **CAUTION—SHOCK HAZARD:** To avoid the risk of electrical shock, do not set up this product or make any electrical or cabling connections, such as the power cord, fax feature, or telephone, during a lightning storm.
- ⚠ **CAUTION—POTENTIAL INJURY:** To avoid the risk of fire or electrical shock, connect the power cord to an appropriately rated and properly grounded electrical outlet that is near the product and easily accessible.
- ⚠ **CAUTION—POTENTIAL INJURY:** To avoid the risk of fire or electrical shock, use only the power cord provided with this product or the manufacturer's authorized replacement.

**⚠ CAUTION—POTENTIAL INJURY:** To reduce the risk of fire, use only a 26 AWG or larger telecommunications (RJ-11) cord when connecting this product to the public switched telephone network. For users in Australia, the cord must be approved by the Australian Communications and Media Authority.

**Warning—Potential Damage:** To avoid loss of data or printer malfunction, do not touch the USB cable, any wireless network adapter, or the printer in the areas shown while actively printing.

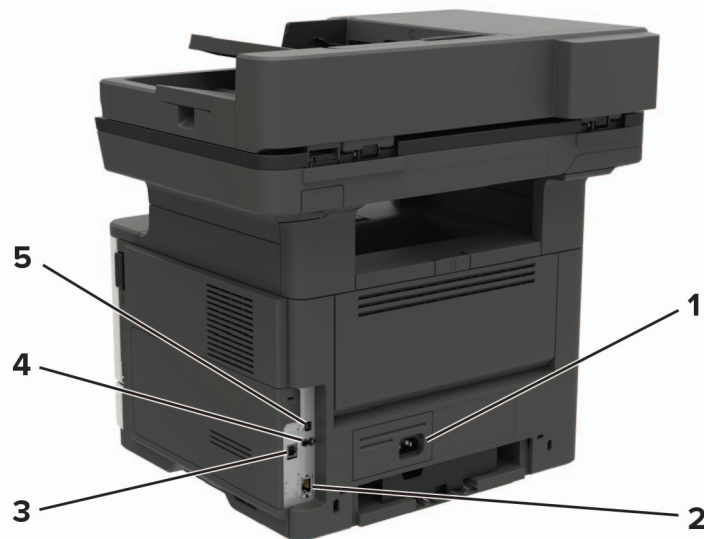

	Use the	To
1	Power cord socket	Connect the printer to an electrical outlet.
2	Ethernet port	Connect the printer to an Ethernet network.
3	LINE port	Connect the printer to an active telephone line through a standard wall jack (RJ-11), DSL filter, or VoIP adapter, or any other adapter that allows you to access the telephone line to send and receive faxes.
4	USB port (678 only)	Attach a keyboard or any compatible option.
5	USB printer port	Connect the printer to a computer.

## Using the control panel

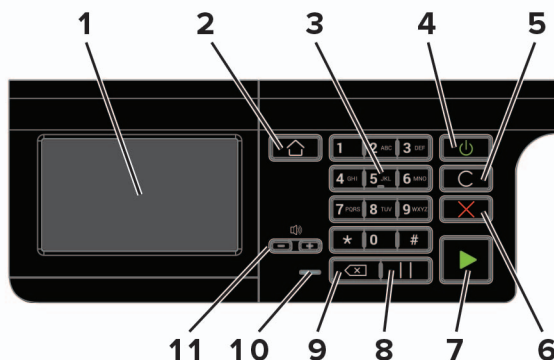

	Use the	To
1	Display	<ul style="list-style-type: none"> <li>View the printer messages and supply status.</li> <li>Set up and operate the printer.</li> </ul>
2	Home button	Go to the home screen.
3	Numeric keypad	Enter numbers or symbols in an input field.
4	Power button	Turn on or turn off the printer. <b>Note:</b> To turn off the printer, press and hold the power button for five seconds.
5	Clear all or Reset button	Reset the default settings of a function such as copying, faxing, or scanning.
6	Stop or Cancel button	Stop the current printer task.
7	Start button	Start a printer task, depending on which mode is selected.
8	Pause button	Place a dial pause in a fax number.
9	Backspace button	Move the cursor backward and delete a character in an input field.
10	Indicator light	Check the printer status.
11	Volume buttons	Adjust the speaker volume.

## Understanding the status of the power button and indicator light

Indicator light	Printer status
Off	The printer is off or in Hibernate mode.
Blue	The printer is ready or processing data.
Red	The printer requires user intervention.

Power button light	Printer status
Off	The printer is off, ready, or processing data.
Solid amber	The printer is in sleep mode.
Blinking amber	The printer is in hibernate mode.

## Using the home screen

**Note:** Your home screen may vary depending on your home screen customization settings, administrative setup, and active embedded solutions.

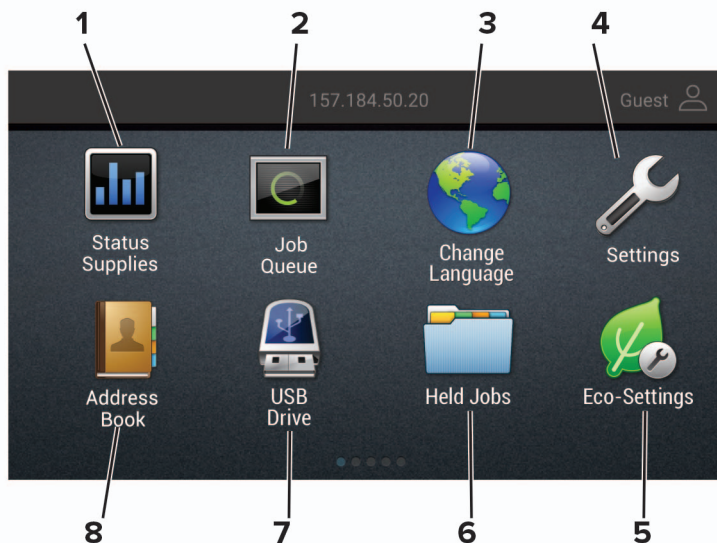

Touch	To
1	<p>Status/Supplies</p> <ul style="list-style-type: none"> <li>Show a warning or error message whenever the printer requires intervention to continue processing.</li> <li>View more information on the printer warning or message, and on how to clear it.</li> </ul> <p><b>Note:</b> You can also access this setting by touching the top section of the home screen.</p>
2	<p>Job Queue</p> <p>Show all the current print jobs.</p> <p><b>Note:</b> You can also access this setting by touching the top section of the home screen.</p>
3	<p>Change Language</p> <p>Change the language on the display.</p>
4	<p>Settings</p> <p>Access the printer menus.</p>
5	<p>Eco-Settings</p> <p>Manage energy consumption, noise, toner, and paper usage settings.</p>
6	<p>Held Jobs</p> <p>Show the print jobs that are held in the printer memory.</p>
7	<p>USB Drive</p> <p>Print photos and documents from a flash drive.</p>
8	<p>Address Book</p> <p>Manage a contact list that other applications on the printer can access.</p>

## Printing the Menu Settings Page

From the home screen, touch **Settings > Reports > Menu Settings Page**.

## Printing the Network Setup Page

From the home screen, touch **Settings** > **Reports** > **Network** > **Network Setup Page**.

# Setting up and using the home screen applications

## Customizing the home screen

- 1 From the control panel, touch **Settings** > **Device** > **Visible Home Screen Icons**.
- 2 Select the icons that you want to appear on the home screen.
- 3 Apply the changes.

## Setting up Card Copy

- 1 Open a web browser, and then type the printer IP address in the address field.

**Notes:**

- View the printer IP address on the printer home screen. The IP address appears as four sets of numbers separated by periods, such as 123.123.123.123.
- If you are using a proxy server, then temporarily disable it to load the web page correctly.

- 2 Click **Apps** > **Card Copy** > **Configure**.

**Notes:**

- Make sure that Display Icon is enabled.
- Make sure that E-mail Settings and Network Share Settings are configured.
- When scanning a card, make sure that the scan resolution does not exceed 200 dpi for color and 400 dpi for black and white.
- When scanning multiple cards, make sure that the scan resolution does not exceed 150 dpi for color and 300 dpi for black and white.

- 3 Apply the changes.

**Note:** You need a printer hard disk to scan multiple cards.

## Using Shortcut Center

- 1 From the home screen, touch **Shortcut Center**, and then select a printer function.
- 2 Touch **Create Shortcut**, and then configure the settings.
- 3 Touch **Save**, and then type a unique shortcut name.
- 4 Apply the changes.



## Using Display Customization

Before using the application, make sure to do the following:

- From the Embedded Web Server, click **Apps > Display Customization > Configure**.
- Enable and configure the screen saver, slideshow, and wallpaper settings.

### Managing screen saver and slide show images

- 1 From the Screen Saver and Slideshow Images section, add, edit, or delete an image.

**Notes:**

- You can add up to 10 images.
- When enabled, the status icons appear on the screen saver only when there are errors, warnings, or cloud-based notifications.

- 2 Apply the changes.

### Changing the wallpaper image

- 1 From the home screen, touch **Change Wallpaper**.
- 2 Select an image to use.
- 3 Apply the changes.

### Running a slide show from a flash drive

- 1 Insert a flash drive into the USB port.
- 2 From the home screen, touch **Slideshow**.

Images appear in alphabetical order.

**Note:** You can remove the flash drive after the slide show starts, but the images are not stored in the printer. If the slide show stops, then insert the flash drive again to view the images.

## Setting up Scan Center

- 1 From the home screen, touch **Scan Center**.
- 2 Select and create a destination, and then configure the settings.

**Notes:**

- When creating a network destination, make sure to validate and adjust the settings until no errors occur.
- Only destinations created from the Embedded Web Server are saved. For more information, see the documentation that came with the solution.

- 3 Apply the changes.

# Managing contacts

## Adding contacts

- 1 Open a web browser, and then type the printer IP address in the address field.

**Notes:**

- View the printer IP address on the printer home screen. The IP address appears as four sets of numbers separated by periods, such as 123.123.123.123.
- If you are using a proxy server, then temporarily disable it to load the web page correctly.

- 2 Click **Address Book**.

- 3 From the Contacts section, add a contact.

**Note:** You can assign the contact to one or more groups.

- 4 If necessary, specify a login method to allow application access.

- 5 Apply the changes.

## Adding groups

- 1 Open a web browser, and then type the printer IP address in the address field.

**Notes:**

- View the printer IP address on the printer home screen. The IP address appears as four sets of numbers separated by periods, such as 123.123.123.123.
- If you are using a proxy server, then temporarily disable it to load the web page correctly.

- 2 Click **Address Book**.

- 3 From the Contact Groups section, add a group name.

**Note:** You can assign one or more contacts to the group.

- 4 Apply the changes.

## Editing contacts or groups

- 1 Open a web browser, and then type the printer IP address in the address field.

**Notes:**

- View the printer IP address on the printer home screen. The IP address appears as four sets of numbers separated by periods, such as 123.123.123.123.
- If you are using a proxy server, then temporarily disable it to load the web page correctly.

- 2 Click **Address Book**.

**3** Do either of the following:

- From the Contacts section, click a contact name, and then edit the information.
- From the Contact Groups section, click a group name, and then edit the information.

**4** Apply the changes.

## Deleting contacts or groups

**1** Open a web browser, and then type the printer IP address in the address field.

**Notes:**

- View the printer IP address on the printer home screen. The IP address appears as four sets of numbers separated by periods, such as 123.123.123.123.
- If you are using a proxy server, then temporarily disable it to load the web page correctly.

**2** Click **Address Book**.

**3** Do either of the following:

- From the Contacts section, select a contact that you want to delete.
- From the Contact Groups section, select a group name that you want to delete.

# Loading paper and specialty media

## Setting the paper size and type

- 1 From the home screen, navigate to:  
**Settings > Paper > Tray Configuration > Paper Size/Type** > select a paper source
- 2 Set the paper size and type.

## Configuring Universal paper settings

- 1 From the home screen, touch **Settings > Paper > Media Configuration > Universal Setup**.
- 2 Configure the settings.

## Loading trays

 **CAUTION—TIPPING HAZARD:** To reduce the risk of equipment instability, load each tray separately. Keep all other trays closed until needed.

- 1 Remove the tray.

**Note:** To avoid paper jams, do not remove trays while the printer is busy.



- 2** Adjust the paper guides to match the size of the paper that you are loading.

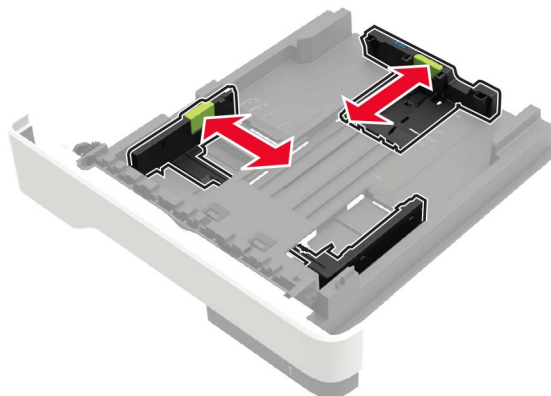

- 3** Flex, fan, and align the paper edges before loading.

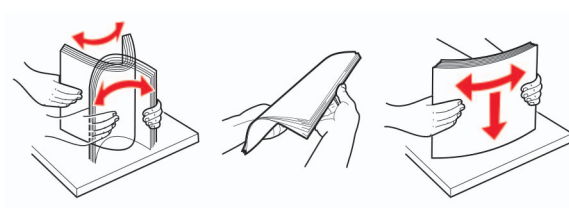

- 4** Load the paper stack with the printable side facedown, and then make sure that the side guides fit snugly against the paper.

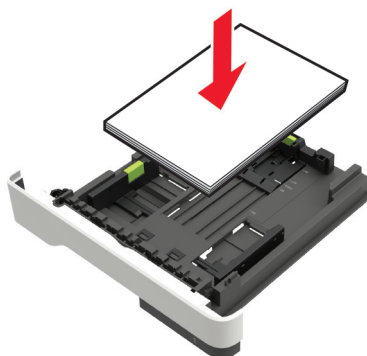

**Notes:**

- Load letterhead facedown with the top edge of the sheet toward the front of the tray for one-sided printing.
- Load letterhead faceup with the bottom edge of the sheet toward the front of the tray for two-sided printing.
- Do not slide paper into the tray.
- To avoid paper jams, make sure that the stack height is below the maximum paper fill indicator.

- 5** Insert the tray.

If necessary, set the paper size and paper type from the control panel to match the paper loaded.

## Loading the multipurpose feeder

1 Open the multipurpose feeder.

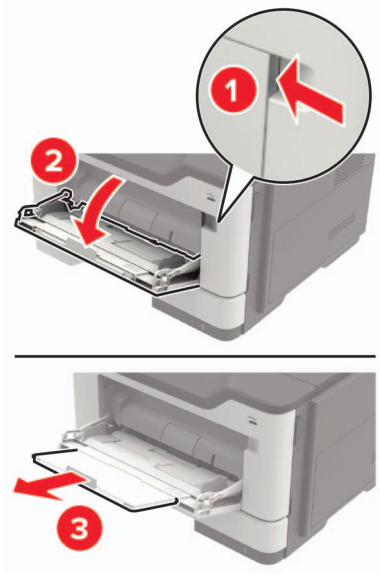

2 Adjust the guide to match the size of the paper that you are loading.



3 Flex, fan, and align the paper edges before loading.

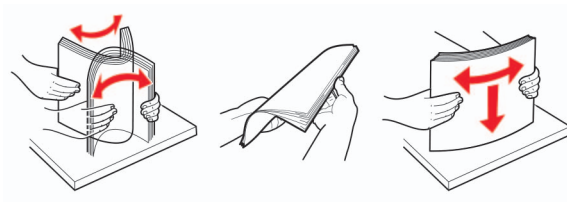

4 Load paper with the printable side faceup.

**Notes:**

- Load letterhead faceup with the top edge of the sheet toward the front of the tray for one-sided printing.
- Load letterhead facedown with the bottom edge of the sheet toward the front of the tray for two-sided printing.

- Load envelopes with the flap facedown on the left side.
- Load European envelopes with the flap facedown and entering the printer first.

**Warning—Potential Damage:** Do not use envelopes with stamps, clasps, snaps, windows, coated linings, or self-stick adhesives.

**5** From the control panel, set the paper size and paper type to match the paper loaded.

## Linking trays

**1** Open a web browser, and then type the printer IP address in the address field.

**Notes:**

- View the printer IP address on the printer home screen. The IP address appears as four sets of numbers separated by periods, such as 123.123.123.123.
- If you are using a proxy server, then temporarily disable it to load the web page correctly.

**2** Click **Settings > Paper > Tray Configuration**.

**3** Set the same paper size and paper type for the trays that you are linking.

**4** Save the settings.

**Note:** You can also change the settings from the printer control panel.

To unlink trays, make sure that no trays have the same paper size and paper type settings.

**Warning—Potential Damage:** The temperature of the fuser varies according to the specified paper type. To avoid printing issues, match the paper type setting in the printer with the paper loaded in the tray.

# Supported paper

## Supported paper sizes

Paper size	Tray	Multipurpose feeder	Two-sided printing	ADF	Scanner glass
<b>A4</b> 210 x 297 mm (8.3 x 11.7 in.)	✓	✓	✓	✓	✓
<b>A5</b> 210 x 148 mm (5.8 x 8.3 in.)	✓	✓	x	✓	✓
<b>A5 LEF*</b> 148 x 210 mm (5.8 x 8.3 in.)	✓	✓	x	✓	✓
<b>A6*</b> 105 x 148 mm (4.1 x 5.8 in.)	✓	✓	x	✓	✓
<b>JIS B5</b> 182 x 257 mm (7.2 x 10.1 in.)	✓	✓	x	✓	✓
<b>Oficio (Mexico)</b> 216 x 340 mm (8.5 x 13.4 in.)	✓	✓	✓	✓	✓
<b>Hagaki</b> 100 x 148 mm (3.9 x 5.8 in.)	x	✓	x	x	✓
<b>Business card</b> 50.8 x 88.9 mm (2 x 3.5 in.)	x	x	x	x	✓
<b>Statement</b> 140 x 216 mm (5.5 x 8.5 in.)	✓	✓	x	✓	✓
<b>Executive</b> 184 x 267 mm (7.3 x 10.5 in.)	✓	✓	x	✓	✓
<b>Letter</b> 216 x 279 mm (8.5 x 11 in.)	✓	✓	✓	✓	✓

\* This paper size is not supported in the optional tray.



Paper size	Tray	Multipurpose feeder	Two-sided printing	ADF	Scanner glass
<b>Legal</b> 216 x 356 mm (8.5 x 14 in.)	✓	✓	✓	✓	✓
<b>Folio</b> 216 x 330 mm (8.5 x 13 in.)	✓	✓	✓	✓	✓
<b>Universal*</b> 76.2 x 127 mm to 216 x 356 mm (3 x 5 in. to 8.5 x 14 in.)	X	✓	X	X	✓
<b>Universal*</b> 105 x 148 mm to 216 x 356 mm (4.13 x 5.83 in. to 8.5 x 14 in.)	✓	X	X	✓	✓
<b>Universal</b> 148 x 210 mm to 216 x 356 mm (5.83 x 8.27 in. to 8.5 x 14 in.)	X	X	X	✓	✓
<b>7 3/4 Envelope (Monarch)</b> 98 x 191 mm (3.9 x 7.5 in.)	X	✓	X	X	✓
<b>9 Envelope</b> 98 x 225 mm (3.9 x 8.9 in.)	X	✓	X	X	✓
<b>10 Envelope</b> 105 x 241 mm (4.1 x 9.5 in.)	X	✓	X	X	✓
<b>DL Envelope</b> 110 x 220 mm (4.3 x 8.7 in.)	X	✓	X	X	✓
<b>C5 Envelope</b> 162 x 229 mm (6.4 x 9 in.)	X	✓	X	X	✓
<b>B5 Envelope</b> 176 x 250 mm (6.9 x 9.8 in.)	X	✓	X	X	✓

\* This paper size is not supported in the optional tray.

Paper size	Tray	Multipurpose feeder	Two-sided printing	ADF	Scanner glass
<b>Other Envelope</b> 76.2 x 127 mm to 216 x 356 mm ( 3 x 5 in. to 8.5 x 14 in.)	X	✓	X	X	✓

\* This paper size is not supported in the optional tray.

## Supported paper types

Paper type	Tray	Multipurpose feeder	Two-sided printing	ADF	Scanner glass
Plain paper	✓	✓	✓	✓	✓
Card stock	X	✓	X	X	✓
Transparency	✓	✓	X	X	✓
Recycled	✓	✓	✓	✓	✓
Paper labels <sup>1</sup>	✓	✓	X	X	✓
Bond <sup>2</sup>	✓	✓	✓	✓	✓
Letterhead	✓	✓	✓	✓	✓
Preprinted	✓	✓	✓	✓	✓
Colored Paper	✓	✓	✓	✓	✓
Light Paper	✓	✓	✓	✓	✓
Heavy Paper <sup>2</sup>	✓	✓	✓	✓	✓
Rough/Cotton	✓	✓	✓	✓	✓
Envelope	X	✓	X	X	✓
Rough envelope	X	✓	X	X	✓

<sup>1</sup> One-sided paper labels designed for laser printers are supported for occasional use. It is recommended to print 20 or fewer pages of paper labels per month. Vinyl, pharmacy, and two-sided labels are not supported.

<sup>2</sup> Bond and Heavy Paper are supported in two-sided printing up to 90-g/m<sup>2</sup> (24-lb) paper weight.

## Supported paper weights

	Tray	Multipurpose feeder	Two-sided printing	ADF
Paper weight	60–120 g/m <sup>2</sup> (16–32 lb)	60–216 g/m <sup>2</sup> (16–58 lb)	60–90 g/m <sup>2</sup> (16–24 lb)	52–120 g/m <sup>2</sup> (14–32 lb)

# Printing

## Printing from a computer

**Note:** For labels, card stock, and envelopes, set the paper size and paper type in the printer before printing the document.

- 1 From the document that you are trying to print, open the Print dialog.
- 2 If necessary, adjust the settings.
- 3 Print the document.

**Note:** For details of the function of the printer driver, refer to the Help of the printer driver.



## Printing from a mobile device

### Printing from a mobile device using Google Cloud Print

Google Cloud Print™ is a printing service that allows you to print to any Google Cloud Print-ready printer.

Before you begin, make sure that:

- The printer is registered to the Google Cloud Print server.
- The Cloud Print plugin is downloaded from the Google Play™ store and is enabled in the mobile device.

- 1 From your Android™ mobile device, open a document or select a document from your file manager.
- 2 Tap  > **Print**.
- 3 Select a printer, and then tap .

### Printing from a mobile device using AirPrint



The AirPrint software feature is a mobile printing solution that allows you to print directly from Apple devices to an AirPrint-certified printer.

#### Notes:

- Make sure that the Apple device and the printer are connected to the same network. If the network has multiple wireless hubs, then make sure that both devices are connected to the same subnet.
- This application is supported only in some Apple devices.

- 1 From your mobile device, select a document from your file manager or launch a compatible application.
- 2 Tap the share icon, and then tap **Print**.

**3** Select a printer.

If necessary, adjust the settings.



**4** Print the document.

## Printing from a mobile device using Wi-Fi Direct®

Wi-Fi Direct® is a printing service that lets you print to any Wi-Fi Direct-ready printer.

**Note:** Make sure that the mobile device is connected to the printer wireless network. For more information, see [“Connecting a mobile device to the printer” on page 123](#).

**1** From your mobile device, launch a compatible application or select a document from your file manager.**2** Depending on your mobile device, do one of the following:

- Tap  > **Print**.
- Tap  > **Print**.
- Tap  > **Print**.

**3** Select a printer, and then adjust the settings, if necessary.**4** Print the document.

## Printing from a flash drive

**1** Insert the flash drive.**Notes:**

- If you insert the flash drive when an error message appears, then the printer ignores the flash drive.
- If you insert the flash drive while the printer is processing other print jobs, then **Busy** appears on the display.

**2** From the display, touch the document that you want to print.

If necessary, configure other print settings.

**3** Send the print job.

To print another document, touch **USB Drive**.

**Warning—Potential Damage:** To avoid loss of data or printer malfunction, do not touch the flash drive or the printer in the area shown while actively printing, reading, or writing from the memory device.



## Supported flash drives and file types

### Flash drives

#### Notes:

- The printer supports high-speed USB flash drives with full-speed standard.
- USB flash drives must support the File Allocation Table (FAT) system.

Many flash drives are tested and approved for use with the printer. For more information, contact the place where you purchased the printer.

### File types

Documents:

- .doc or .docx
- .xls or .xlsx
- .ppt or .pptx
- .pdf
- .xps

Images:

- .dcx
- .gif
- .jpeg or .jpg
- .bmp
- .pcx
- .tiff or .tif
- .png

## Configuring confidential jobs

- 1 From the control panel, navigate to:  
**Settings > Security > Confidential Print Setup**
- 2 Configure the settings.

Use	To
Max Invalid PIN	Set the number of times an invalid PIN can be entered. <b>Note:</b> When the limit is reached, the print jobs for that user name are deleted.
Confidential Job Expiration	Set the expiration time for confidential print jobs. <b>Note:</b> Confidential held jobs are stored in the printer until they are released or deleted manually.
Repeat Job Expiration	Set the expiration time for a repeat print job. <b>Note:</b> Repeat held jobs are stored in the printer memory for reprinting.
Verify Job Expiration	Set the expiration time that the printer prints a copy before printing the remaining copies. <b>Note:</b> Verify jobs print one copy to check if it is satisfactory before printing the remaining copies.
Reserve Job Expiration	Set the expiration time that the printer stores print jobs. <b>Note:</b> Reserve held jobs are automatically deleted after printing.
Require All Jobs to be Held	Set the printer to hold all print jobs.
Keep duplicate documents	Set the printer to print all documents with the same file name.

## Printing confidential and other held jobs

### For Windows users

- 1 With a document open, click **File > Print**.
- 2 Click **Properties, Preferences, Options, or Setup**.
- 3 Click **Print and Hold**.

- 4 Select **Use Print and Hold**, and then assign a user name.
- 5 Select the print job type (Confidential, Repeat, Reserve, or Verify).  
If the print job is confidential, then enter a four-digit PIN.
- 6 Click **OK** or **Print**.
- 7 From the printer home screen, release the print job.
  - For confidential print jobs, touch **Held jobs** > select your user name > **Confidential** > enter the PIN > select the print job > configure the settings > **Print**.
  - For other print jobs, touch **Held jobs** > select your user name > select the print job > configure the settings > **Print**.

### For Macintosh users

- 1 With a document open, choose **File** > **Print**.
- 2 From the Preview or Media & Quality menu, choose **PIN Printing**.
- 3 Enable **Print with PIN**, and then enter a four-digit PIN.
- 4 Click **Print**.
- 5 From the printer home screen, release the print job. Touch **Held jobs** > select your computer name > **Confidential** > enter the PIN > select the print job > **Print**.

## Printing a font sample list

- 1 From the home screen, touch **Settings** > **Reports** > **Print** > **Print Fonts**.
- 2 Touch **PCL Fonts** or **PostScript Fonts**.

## Canceling a print job

### From the printer control panel

- 1 From the home screen, touch **Job Queue**.  
**Note:** You can also access this setting by touching the top section of the home screen.
- 2 Select the job to cancel.

### From the computer

- 1 Depending on the operating system, do either of the following:
  - Open the printers folder, and then select your printer.
  - From the System Preferences in the Apple menu, navigate to your printer.
- 2 Select the job to cancel.



# Copying

## Making copies

- 1 Load an original document into the ADF tray or on the scanner glass.

**Note:** To avoid a cropped image, make sure that the original document and output have the same paper size.

- 2 From the home screen, touch **Copy**, and then specify the number of copies.

If necessary, adjust the copy settings.

- 3 Copy the document.

**Note:** To make a quick copy, from the control panel, press .

## Copying photos

- 1 Place a photo on the scanner glass.

- 2 From the control panel, navigate to:

**Copy > Settings > Content > Content Type > Photo**

- 3 From the Content Source menu, select the setting that best matches the original photo.

- 4 Copy the document.

## Copying on letterhead

- 1 Load an original document into the ADF tray or on the scanner glass.

- 2 From the home screen, touch **Copy > Copy From** > select the size of the original document.

- 3 Touch **Copy To**, and then select the paper source that contains the letterhead.

If you loaded the letterhead into the multipurpose feeder, then navigate to:

**Copy To > Multipurpose Feeder > select a paper size > Letterhead**

- 4 Copy the document.

## Copying on both sides of the paper (two-sided)

- 1 Load an original document into the ADF tray or on the scanner glass.

- 2 From the home screen, touch **Copy > Settings > Paper Setup**.

- 3 Adjust the settings.

- 4 Copy the document.

## Reducing or enlarging copies

- 1 Load an original document into the ADF tray or on the scanner glass.
- 2 From the control panel, navigate to:  
**Copy > Settings > Scale** > specify a scale value  
**Note:** Changing the size of the original document or output after setting Scale restores the scale value to Auto.
- 3 Copy the document.

## Collating copies

- 1 Load an original document into the ADF tray or on the scanner glass.
- 2 From the control panel, navigate to:  
**Copy > Settings > Collate > On [1,2,1,2,1,2]**
- 3 Copy the document.

## Placing separator sheets between copies

- 1 Load an original document into the ADF tray or on the scanner glass.
- 2 From the control panel, navigate to:  
**Copy > Settings > Separator Sheets** > adjust the settings
- 3 Copy the document.

## Copying multiple pages onto a single sheet

- 1 Load an original document into the ADF tray or on the scanner glass.
- 2 From the control panel, navigate to:  
**Copy > Settings > Pages per Side** > adjust the settings
- 3 Copy the document.

## Creating a copy shortcut

- 1 From the home screen, touch **Copy**.
- 2 Adjust the settings, and then touch .
- 3 Enter a shortcut name.
- 4 Apply the changes.

# E-mailing

## Configuring the e-mail server settings

You can send scanned documents through e-mail after setting up the SMTP server. For more information on SMTP settings, contact your e-mail provider.

### Using the control panel

- 1 From the home screen, touch **Settings** > **E-mail** > **E-mail Setup**.
- 2 Configure the settings.

### Using the Embedded Web Server

- 1 Open a web browser, and then type the printer IP address in the address field.

#### Notes:

- View the printer IP address on the printer home screen. The IP address appears as four sets of numbers separated by periods, such as 123.123.123.123.
- If you are using a proxy server, then temporarily disable it to load the web page correctly.

- 2 Click **Settings** > **E-mail**.
- 3 From the E-mail Setup section, configure the settings.
- 4 Click **Save**.

## Sending an e-mail

### Using the control panel

- 1 Load an original document into the ADF tray or on the scanner glass.
- 2 From the home screen, touch **E-mail**, and then enter the needed information.  
**Note:** You can also enter the recipient using the address book or shortcut number.
- 3 If necessary, configure the output file type settings.
- 4 Send the e-mail.

### Using the shortcut number

- 1 From the control panel, press **#**, and then enter the shortcut number using the keypad.
- 2 Send the e-mail.

## Creating an e-mail shortcut

**Note:** You may need administrative rights to create a shortcut.

- 1 Open a web browser, and then type the printer IP address in the address field.

**Notes:**

- View the printer IP address on the home screen. The IP address appears as four sets of numbers separated by periods, such as 123.123.123.123.
- If you are using a proxy server, then temporarily disable it to load the web page correctly.

- 2 Click **Shortcuts > Add Shortcut**.

- 3 From the Shortcut Type menu, select **E-mail**, and then configure the settings.

- 4 Apply the changes.

# Faxing

## Setting up the printer to fax

### Notes:

- The following connection methods are applicable only in some countries or regions.
- During the initial printer setup, clear the fax function check box and any other function you plan to set up later, and then select **Continue**.
- If the fax function is enabled and not fully set up, then the indicator light may blink red.

**Warning—Potential Damage:** To avoid loss of data or printer malfunction, do not touch cables or the printer in the area shown while actively sending or receiving a fax.

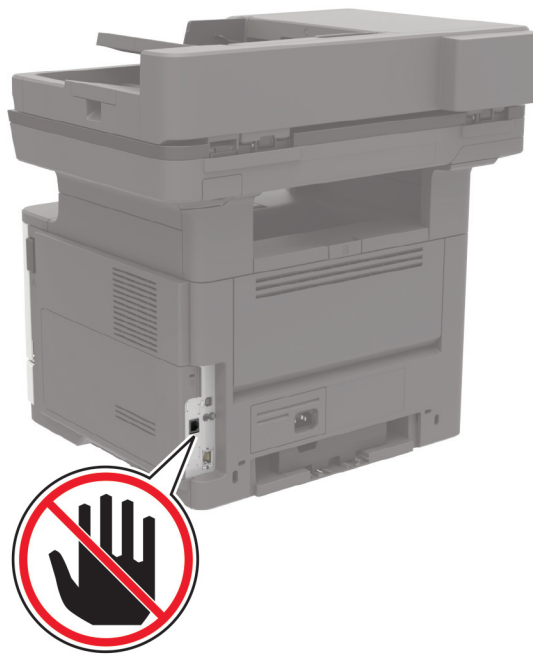

## Configuring the SMTP server for fax

### From the control panel

- 1 From the control panel, touch **Settings > Fax > Fax Server Setup > Fax Server E-mail Settings**.
- 2 Configure the settings.

**Note:** To use the SMTP server setting for e-mail, enable **Use E-mail SMTP Server**.

### From the Embedded Web Server

- 1 Open a web browser, and then type the printer IP address in the address field.

**Notes:**

- View the printer IP address on the printer home screen. The IP address appears as four sets of numbers separated by periods, such as 123.123.123.123.
- If you are using a proxy server, then temporarily disable it to load the web page correctly.

**2** Click **Settings > Fax > Fax Server Setup**.

**3** From the Fax Server E-mail Settings section, configure the settings.

**Note:** To use the SMTP server setting for e-mail, enable **Use E-mail SMTP Server**.

**4** Click **Save**.

## Setting up fax using a standard telephone line

 **CAUTION—SHOCK HAZARD:** To avoid the risk of electrical shock, do not set up this product or make any electrical or cabling connections, such as the power cord, fax feature, or telephone, during a lightning storm.

 **CAUTION—SHOCK HAZARD:** To avoid the risk of electrical shock, do not use the fax feature during a lightning storm.

 **CAUTION—POTENTIAL INJURY:** To reduce the risk of fire, use only a 26 AWG or larger telecommunications (RJ-11) cord when connecting this product to the public switched telephone network. For users in Australia, the cord must be approved by the Australian Communications and Media Authority.

### Setup 1: Printer is connected to a dedicated fax line

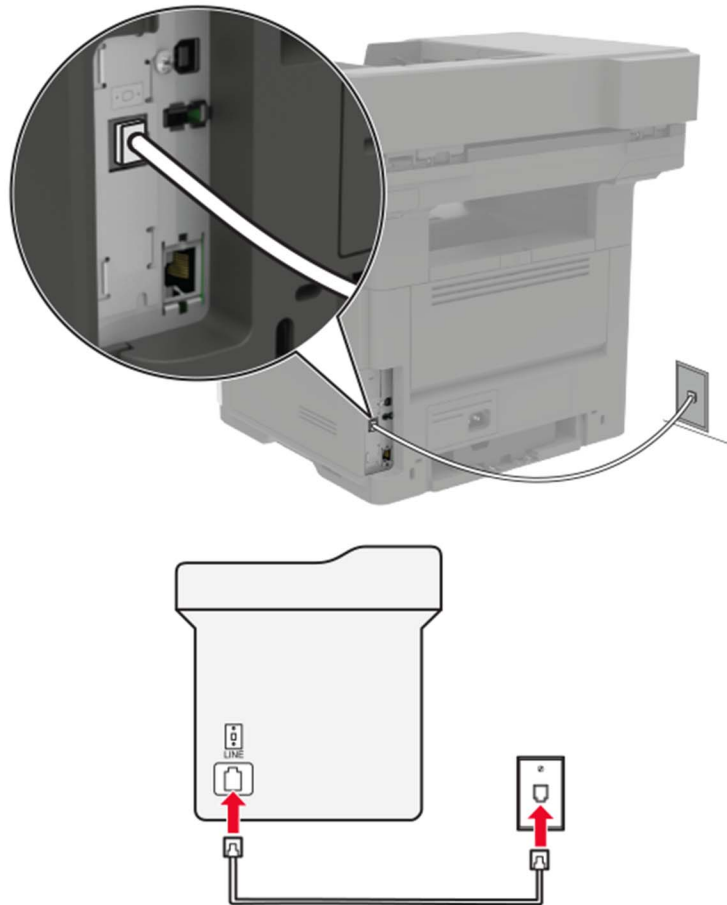

- 1 Connect one end of the telephone cable to the line port of the printer.
- 2 Connect the other end of the cable to an active analog wall jack.

#### Notes:

- You can set the printer to receive faxes automatically (Auto Answer On) or manually (Auto Answer Off).
- If you want to receive faxes automatically, then set the printer to pick up on a specified number of rings.

### Setup 2: Printer is sharing the line with an answering machine

**Note:** If you subscribe to a distinctive ring service, then make sure that you set the correct ring pattern for the printer. Otherwise, the printer does not receive faxes even if you have set it to receive faxes automatically.

### Connected to different wall jacks

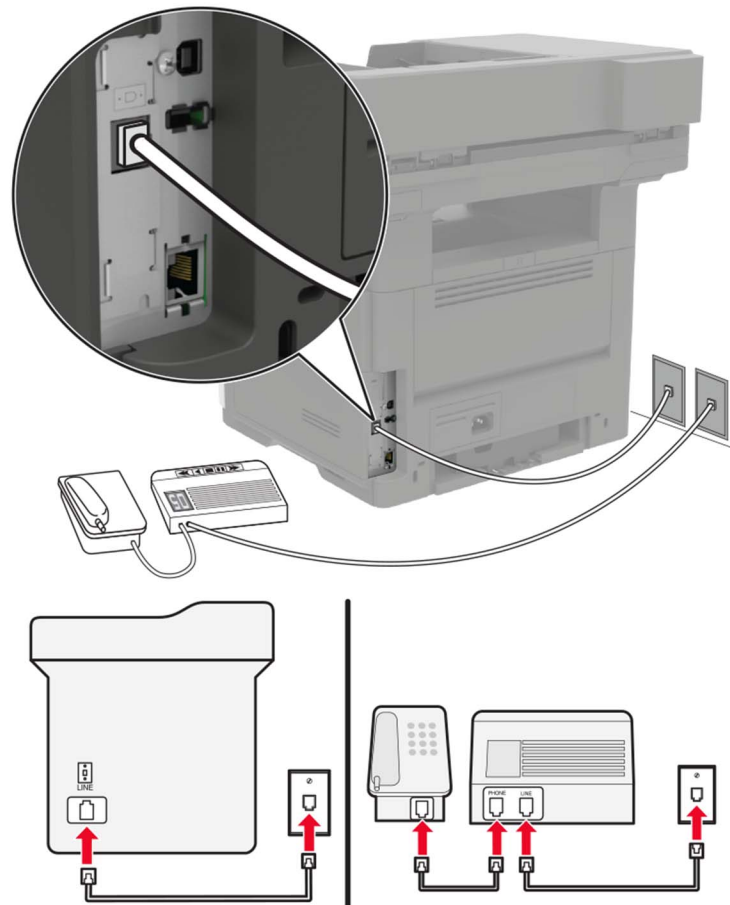

- 1 Connect one end of the telephone cable to the line port of the printer.
- 2 Connect the other end of the cable to an active analog wall jack.

#### Notes:

- If you have only one telephone number on your line, then set the printer to receive faxes automatically.
- Set the printer to pick up calls two rings after the answering machine. For example, if the answering machine picks up calls after four rings, then set the printer Rings to Answer setting to six.

### Setting up fax in countries or regions with different telephone wall jacks and plugs

**⚠ CAUTION—SHOCK HAZARD:** To avoid the risk of electrical shock, do not set up this product or make any electrical or cabling connections, such as the power cord, fax feature, or telephone, during a lightning storm.

**⚠ CAUTION—SHOCK HAZARD:** To avoid the risk of electrical shock, do not use the fax feature during a lightning storm.



**⚠ CAUTION—POTENTIAL INJURY:** To reduce the risk of fire, use only a 26 AWG or larger telecommunications (RJ-11) cord when connecting this product to the public switched telephone network. For users in Australia, the cord must be approved by the Australian Communications and Media Authority.

The standard wall jack adopted by most countries or regions is RJ11. If the wall jack or equipment in your facility is not compatible with this type of connection, then use a telephone adapter. An adapter for your country or region may not come with your printer, and you may need to purchase it separately.

There may be an adapter plug installed in the telephone port of the printer. Do not remove the adapter plug from the telephone port of the printer if you are connecting to a serial or cascaded telephone system.

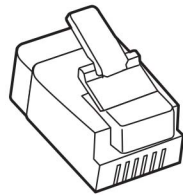

### Connecting the printer to a non-RJ11 wall jack

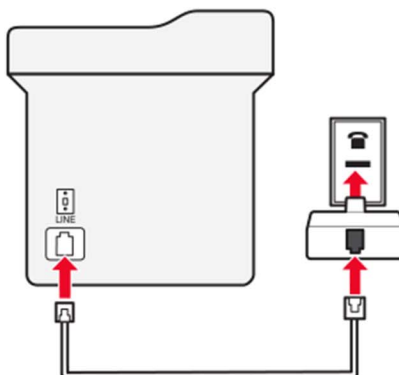
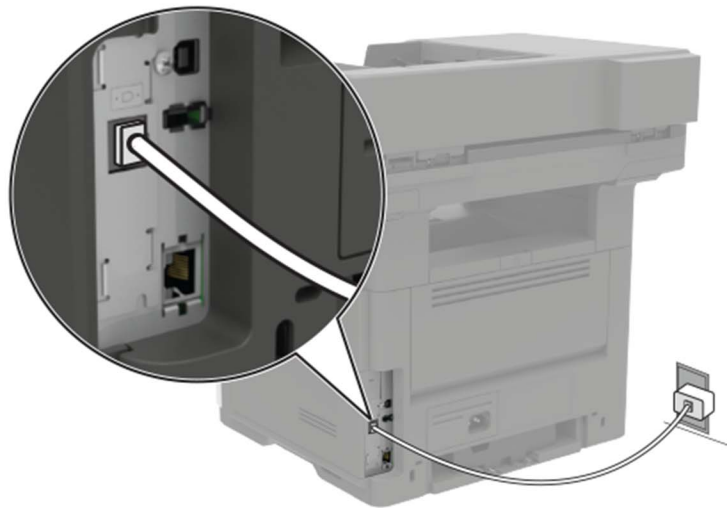

- 1 Connect one end of the telephone cable to the line port of the printer.
- 2 Connect the other end of the cable to the RJ11 adapter, and then connect the adapter to the wall jack.
- 3 If you want to connect another device with a non-RJ11 connector to the same wall jack, then connect it directly to the telephone adapter.

### Connecting the printer to a wall jack in Germany

The German wall jack has two kinds of ports. The N ports are for fax machines, modems, and answering machines. The F port is for telephones. Connect the printer to any of the N ports.

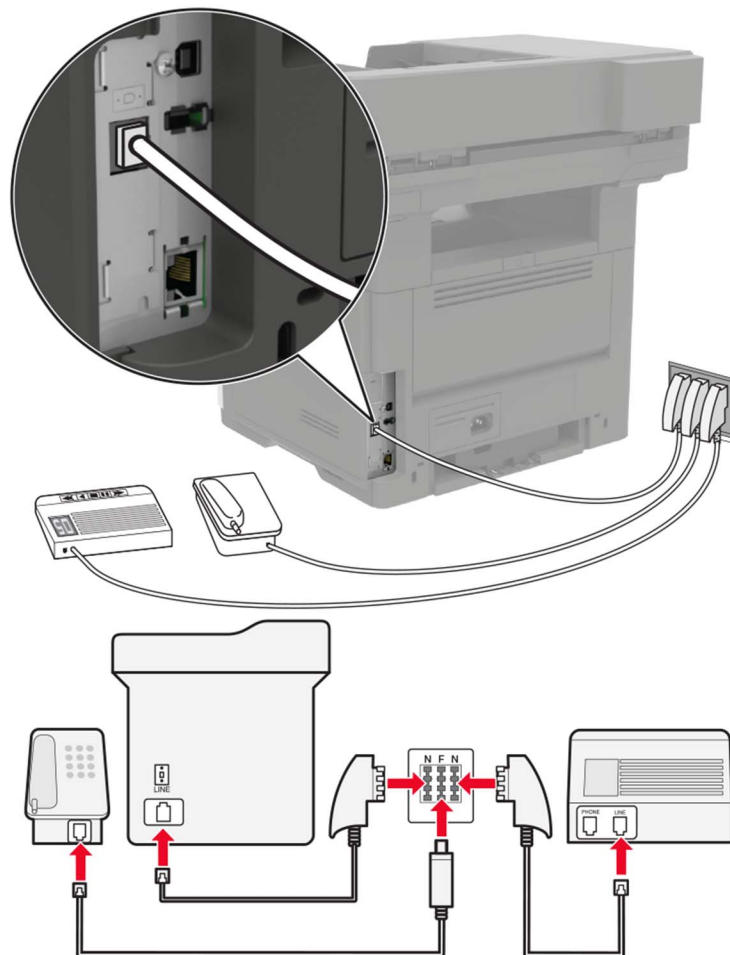

- 1 Connect one end of the telephone cable to the line port of the printer.
- 2 Connect the other end of the cable to the RJ11 adapter, and then connect the adapter to an N port.
- 3 If you want to connect a telephone and answering machine to the same wall jack, then connect the devices as shown.

## Connecting to a distinctive ring service

A distinctive ring service lets you have multiple telephone numbers on one telephone line. Each telephone number is assigned a different ring pattern.

- 1 From the home screen, touch **Settings > Fax > Fax Setup > Fax Receive Settings > Admin Controls > Answer On**.
- 2 Select a ring pattern.

## Setting the fax date and time

- 1 From the home screen, touch **Settings > Device > Preferences > Date and Time > Configure**.
- 2 Configure the settings.

## Configuring daylight saving time

- 1 From the home screen, touch **Settings > Device > Preferences > Date and Time > Configure**.
- 2 In the Time Zone menu, select **Custom**.
- 3 Configure the settings.

## Sending a fax

### Using the control panel

- 1 Load the original document into the ADF tray or on the scanner glass.
- 2 From the home screen, touch **Fax**, and then enter the needed information.
- 3 If necessary, configure other fax settings.
- 4 Send the fax job.

### Using the computer

**Note:** Make sure that the Universal Fax driver is installed.

#### For Windows users

- 1 With a document open, click **File > Print**.
- 2 Select the printer, and then click **Properties, Preferences, Options, or Setup**.
- 3 Click **Fax > Enable fax**, and then enter the recipient number.
- 4 If necessary, configure other fax settings.
- 5 Send the fax job.

### For Macintosh users

- 1 With a document open, choose **File > Print**.
- 2 Select the printer and enter the recipient number.
- 3 If necessary, configure other fax settings.
- 4 Send the fax job.

## Scheduling a fax

- 1 Load the original document into the ADF tray or on the scanner glass.
- 2 From the home screen, navigate to:  
**Fax > To > enter the fax number > Done**
- 3 Touch **Send Time**, configure the settings, and then touch **Done**.
- 4 Send the fax.

## Creating a fax destination shortcut

- 1 From the home screen, touch **Fax > To**.
- 2 Enter the recipient number, and then touch **Done**.
- 3 Touch .
- 4 Create a shortcut.

## Changing the fax resolution

- 1 Load an original document into the ADF tray or on the scanner glass.
- 2 From the home screen, touch **Fax**, and then enter the needed information.
- 3 Adjust the Resolution setting.
- 4 Send the fax job.

## Adjusting the fax darkness

- 1 Load an original document into the ADF tray or on the scanner glass.
- 2 From the home screen, touch **Fax**, and then enter the needed information.
- 3 Adjust the Darkness setting.
- 4 Send the fax job.

## Printing a fax log

- 1 From the home screen, touch **Settings** > **Reports** > **Fax**.
- 2 Touch **Fax Job Log** or **Fax Call Log**.

## Blocking junk faxes

- 1 From the home screen, touch **Settings** > **Fax** > **Fax Setup** > **Fax Receive Settings** > **Admin Controls**.
- 2 Set Block No Name Fax to **On**.

## Holding faxes

- 1 From the home screen, touch **Settings** > **Fax** > **Fax Setup** > **Fax Receive Settings** > **Holding Faxes**.
- 2 Select a mode.

## Forwarding a fax

- 1 From the home screen, touch **Settings** > **Fax** > **Fax Setup** > **Fax Receive Settings** > **Admin Controls**.
- 2 Touch **Fax Forwarding** > **Forward**.
- 3 Configure the Forward to and Confirmation E-mail settings.

# Scanning

## Scanning to a computer

Before you begin, make sure that the computer and the printer are connected to the same network.

### For Windows users

**Note:** Make sure that the printer is added to the computer.

- 1 Load an original document into the automatic document feeder or on the scanner glass.
- 2 From the computer, open Windows Fax and Scan.
- 3 From the Source menu, select a scanner source.
- 4 If necessary, change the scan settings.
- 5 Scan the document.

### For Macintosh users

- 1 Load an original document into the automatic document feeder or on the scanner glass.
- 2 From a computer, open Printers & Scanners.
- 3 Select a printer.  
If no printer is available, then add a printer.

**Note:** For the printer software setting, use either AirPrint or Secure AirPrint.

- 4 Click **Scan > Open Scanner**.
- 5 From the Scanner window, do one or more of the following:
  - Select where you want to save the scanned document.
  - Select the size of the original document.
  - To scan from the ADF, enable **Use Document Feeder**.
  - Click **Show Details**, and then configure the scan settings.
- 6 Click **Scan**.

## Creating an FTP shortcut

- 1 From the home screen, touch **FTP**.
- 2 Enter the FTP server address, and then touch .
- 3 Create a shortcut.

## Scanning to an FTP server

- 1 Load the original document into the ADF tray or on the scanner glass.
- 2 From the home screen, touch **FTP**, and then enter the needed information.
- 3 If necessary, configure other FTP settings.
- 4 Send the FTP job.

## Scanning to a flash drive

- 1 Load an original document into the ADF tray or on the scanner glass.
- 2 Insert the flash drive.



- 3 Touch **Scan to USB** and adjust the settings if necessary.

**Note:** If the USB Drive screen does not appear, then touch **USB Drive** on the home screen.

- 4 Scan the document.

**Warning—Potential Damage:** To avoid loss of data or printer malfunction, do not touch the flash drive or the printer in the area shown while actively printing, reading, or writing from the memory device.





# Understanding the printer menus

## Menu map

Device	<ul style="list-style-type: none"> <li>• <a href="#">Preferences</a></li> <li>• <a href="#">Eco-Mode</a></li> <li>• <a href="#">Remote Operator Panel</a></li> <li>• <a href="#">Notifications</a></li> <li>• <a href="#">Power Management</a></li> </ul>	<ul style="list-style-type: none"> <li>• <a href="#">Accessibility</a></li> <li>• <a href="#">Restore Factory Defaults</a></li> <li>• <a href="#">Maintenance</a></li> <li>• <a href="#">Visible Home Screen Icons</a></li> <li>• <a href="#">About This Printer</a></li> </ul>
Print	<ul style="list-style-type: none"> <li>• <a href="#">Layout</a></li> <li>• <a href="#">Setup</a></li> <li>• <a href="#">Quality</a></li> <li>• <a href="#">Job Accounting</a></li> <li>• <a href="#">XPS</a></li> </ul>	<ul style="list-style-type: none"> <li>• <a href="#">PDF</a></li> <li>• <a href="#">PostScript</a></li> <li>• <a href="#">PCL</a></li> <li>• <a href="#">HTML</a></li> <li>• <a href="#">Image</a></li> </ul>
Paper	<ul style="list-style-type: none"> <li>• <a href="#">Tray Configuration</a></li> </ul>	<ul style="list-style-type: none"> <li>• <a href="#">Media Configuration</a></li> </ul>
Copy	<a href="#">Copy Defaults</a>	
Fax	<ul style="list-style-type: none"> <li>• <a href="#">Fax Mode</a></li> <li>• <a href="#">Fax Setup</a></li> </ul>	<ul style="list-style-type: none"> <li>• <a href="#">Fax Server Setup</a></li> </ul>
E-mail	<ul style="list-style-type: none"> <li>• <a href="#">E-mail Setup</a></li> <li>• <a href="#">E-mail Defaults</a></li> </ul>	<ul style="list-style-type: none"> <li>• <a href="#">Web Link Setup</a></li> </ul>
FTP	<a href="#">FTP Defaults</a>	
USB Drive	<ul style="list-style-type: none"> <li>• <a href="#">Flash Drive Scan</a></li> </ul>	<ul style="list-style-type: none"> <li>• <a href="#">Flash Drive Print</a></li> </ul>
Network/Ports	<ul style="list-style-type: none"> <li>• <a href="#">Network Overview</a></li> <li>• <a href="#">Wireless</a></li> <li>• <a href="#">Ethernet</a></li> <li>• <a href="#">TCP/IP</a></li> <li>• <a href="#">SNMP</a></li> <li>• <a href="#">IPSec</a></li> <li>• <a href="#">802.1x</a></li> </ul>	<ul style="list-style-type: none"> <li>• <a href="#">LPD Configuration</a></li> <li>• <a href="#">HTTP/FTP Settings</a></li> <li>• <a href="#">ThinPrint</a></li> <li>• <a href="#">USB</a></li> <li>• <a href="#">Restrict external network access</a></li> <li>• <a href="#">Google Cloud Print</a></li> <li>• <a href="#">Wi-Fi Direct</a></li> </ul>
Security	<ul style="list-style-type: none"> <li>• <a href="#">Login Methods</a></li> <li>• <a href="#">Schedule USB Devices</a></li> <li>• <a href="#">Security Audit Log</a></li> <li>• <a href="#">Login Restrictions</a></li> <li>• <a href="#">Confidential Print Setup</a></li> </ul>	<ul style="list-style-type: none"> <li>• <a href="#">Disk Encryption</a></li> <li>• <a href="#">Erase Temporary Data Files</a></li> <li>• <a href="#">Solutions LDAP Settings</a></li> <li>• <a href="#">Mobile Services Management</a></li> <li>• <a href="#">Miscellaneous</a></li> </ul>
Reports	<ul style="list-style-type: none"> <li>• <a href="#">Menu Settings Page</a></li> <li>• <a href="#">Device</a></li> <li>• <a href="#">Print</a></li> </ul>	<ul style="list-style-type: none"> <li>• <a href="#">Shortcuts</a></li> <li>• <a href="#">Fax</a></li> <li>• <a href="#">Network</a></li> </ul>

<a href="#">Help</a>	<ul style="list-style-type: none"> <li>• Print All Guides</li> <li>• Connection Guide</li> <li>• Copy Guide</li> <li>• E-mail Guide</li> <li>• Fax Guide</li> <li>• FTP Guide</li> <li>• Information Guide</li> </ul>	<ul style="list-style-type: none"> <li>• Media Guide</li> <li>• Mono Quality Guide</li> <li>• Moving Guide</li> <li>• Print Quality Guide</li> <li>• Scan Guide</li> <li>• Supplies Guide</li> </ul>
<a href="#">Troubleshooting</a>	Print Quality Test Pages	Cleaning the scanner

## Device

### Preferences

Menu item	Description
<b>Display Language</b> [List of languages]	Set the language of the text that appears on the display.
<b>Country/Region</b> [List of countries or regions]	Identify the country or region where the printer is configured to operate.
<b>Run initial setup</b> On Off*	Run the setup wizard.
<b>Keyboard</b> Keyboard Type [List of languages]	Select a language as a keyboard type.  <b>Notes:</b> <ul style="list-style-type: none"> <li>• All the Keyboard Type values may not appear or may require special hardware to appear.</li> <li>• This menu item appears only in some printer models.</li> </ul>
<b>Displayed information</b> Display Text 1 [IP Address*] Display Text 2 [Date/Time*] Custom Text 1 Custom Text 2	Specify the information to appear on the home screen.  <b>Note:</b> Custom Text 1 and Custom Text 2 appear only in some printer models.
<b>Date and Time</b> Configure Current Date and Time Manually Set Date and Time Date Format [MM-DD-YYYY*] Time Format [12 hour A.M./P.M.*] Time Zone [GMT*]	Configure the printer date and time.
<b>Note:</b> An asterisk (*) next to a value indicates the factory default setting.	

Menu item	Description
<b>Date and Time</b> Network Time Protocol Enable NTP [On*] NTP Server Enable Authentication	Configure the settings for Network Time Protocol (NTP). <b>Notes:</b> <ul style="list-style-type: none"> <li>• Enable Authentication appears only in some printer models.</li> <li>• When Enable Authentication is set to MD5 key, Key ID and Password appear.</li> </ul>
<b>Paper Sizes</b> U.S.* Metric	Specify the unit of measurement for paper sizes. <b>Note:</b> The country or region selected in the initial setup wizard determines the initial paper size setting.
<b>Screen Brightness</b> 20–100% (100*)	Adjust the brightness of the display. <b>Note:</b> This menu item appears only in some printer models.
<b>Flash Drive Access</b> Enabled* Disabled	Enable access to the flash drive.
<b>Allow Background Removal</b> On* Off	Specify whether background removal is allowed.
<b>Allow Custom Job scans</b> On* Off	Scan multiple jobs to one file. <b>Note:</b> This menu setting appears only when a hard disk is installed.
<b>One Page Flatbed Scanning</b> On Off*	Set copies from the scanner glass to only one page at a time.
<b>Audio Feedback</b> Button Feedback On* Off	Enable audio feedback for button presses, panel interactions, paper loaded prompts, and error notifications. <b>Note:</b> This menu item appears only in some printer models.
<b>Audio Feedback</b> Volume 1–10 (5*)	Adjust the volume of the printer speakers. <b>Notes:</b> <ul style="list-style-type: none"> <li>• Changes to the volume are applied after the current user session ends.</li> <li>• This menu item appears only in some printer models.</li> </ul>
<b>Screen Timeout</b> 10–300 (60*)	Set the idle time in seconds before the display shows the home screen, or before the printer logs off a user account automatically.
<b>Note:</b> An asterisk (*) next to a value indicates the factory default setting.	

## Eco-Mode

Menu item	Description
<b>Print</b> Sides 1-Sided* 2-Sided	Specify whether to print on one side or two sides of the paper.
<b>Print</b> Pages per Side Off* 2 pages per side 3 pages per side 4 pages per side 6 pages per side 9 pages per side 12 pages per side 16 pages per side	Print multiple page images on one side of a sheet of paper.
<b>Print</b> Toner Darkness 1–10 (8*)	Determine the lightness or darkness of text images.
<b>Copy</b> Sides 1 sided to 1 sided* 1 sided to 2 sided 2 sided to 1 sided 2 sided to 2 sided	Specify the scanning behavior based on the original document.
<b>Copy</b> Pages per Side Off* 2 Portrait pages 4 Portrait pages 2 Landscape pages 4 Landscape pages	Specify the scanning behavior based on the original document.
<b>Copy</b> Darkness 1–9 (5*)	Determine the darkness of the scanned text images.
<b>Note:</b> An asterisk (*) next to a value indicates the factory default setting.	

## Remote Operator Panel

Menu item	Description
<b>External VNC Connection</b> Don't Allow* Allow	Connect an external Virtual Network Computing (VNC) client to the remote control panel.
<b>Authentication Type</b> None* Standard Authentication	Set the authentication type when accessing the VNC client server.
<b>VNC Password</b>	Specify the password to connect to the VNC client server. <b>Note:</b> This menu item appears only if Authentication Type is set to Standard Authentication.
<b>Note:</b> An asterisk (*) next to a value indicates the factory default setting.	

## Notifications

Menu item	Description
<b>ADF Loaded Beep</b> Off On*	Enable a sound when loading paper into the ADF.
<b>Alarm Control</b> Off Single* Continuous	Set the number of times that the alarm sounds when the printer requires user intervention.
<b>Supplies</b> Show Supply Estimates Show estimates* Do not show estimates	Show the estimated status of the supplies.
<b>Supplies</b> Display Estimates Pages* Percent	Determine the unit that the printer uses to estimate supply usage and trigger custom notifications when user intervention is required. <b>Note:</b> This menu item appears only in the Embedded Web Server.
<b>Supplies</b> Cartridge Alarm Off Single* Continuous	Set the number of times that the alarm sounds when the toner cartridge is low.
<b>Supplies</b> Custom Supply Estimates Show Estimates Do Not Show Estimates*	Configure notification settings when the printer requires user intervention. <b>Note:</b> This menu item appears only in the Embedded Web Server.
<b>Note:</b> An asterisk (*) next to a value indicates the factory default setting.	

Menu item	Description
<p><b>E-mail Alerts Setup</b></p> <ul style="list-style-type: none"> <li>E-mail Setup                             <ul style="list-style-type: none"> <li>Primary SMTP Gateway</li> <li>Primary SMTP Gateway Port (25*)</li> <li>Secondary SMTP Gateway</li> <li>Secondary SMTP Gateway Port (25*)</li> <li>SMTP Timeout (30 seconds*)</li> <li>Reply Address                                     <ul style="list-style-type: none"> <li>Always use SMTP default Reply Address(Off*)</li> <li>Use SSL/TLS(Disabled*)</li> <li>Require Trusted Certificate(On*)</li> </ul> </li> <li>SMTP Server Authentication (No authentication required*)</li> <li>Device-Initiated E-mail(None*)</li> <li>User-Initiated E-mail(None*)</li> <li>Use Active Directory Device Credentials(Off*)</li> <li>Device Userid</li> <li>Device Password</li> <li>Kerberos 5 REALM</li> <li>NTLM Domain</li> <li>Disable "SMTP server not set up" error(Off*)</li> </ul> </li> </ul>	<p>Configure the e-mail settings of the printer.</p>
<p><b>E-mail Alerts Setup</b></p> <ul style="list-style-type: none"> <li>Setup E-mail Lists and Alerts                             <ul style="list-style-type: none"> <li>E-mail List 1</li> <li>E-mail List 2</li> <li>E-mail Events</li> </ul> </li> </ul>	<p>Specify the e-mail addresses and enable the e-mail alert events.</p> <p><b>Note:</b> This menu item appears only in the Embedded Web Server.</p>
<p><b>Error Prevention</b></p> <ul style="list-style-type: none"> <li>Jam Assist                             <ul style="list-style-type: none"> <li>Off</li> <li>On*</li> </ul> </li> </ul>	<p>Set the printer to flush blank pages or pages with partial prints automatically after a jammed page has been cleared.</p>
<p><b>Error Prevention</b></p> <ul style="list-style-type: none"> <li>Auto Continue                             <ul style="list-style-type: none"> <li>Off</li> <li>On* (5 seconds)</li> </ul> </li> </ul>	<p>Let the printer continue processing or printing a job automatically after clearing certain printer conditions that require user intervention.</p>
<p><b>Error Prevention</b></p> <ul style="list-style-type: none"> <li>Auto Reboot                             <ul style="list-style-type: none"> <li>Auto Reboot                                     <ul style="list-style-type: none"> <li>Reboot when idle</li> <li>Reboot always*</li> <li>Reboot never</li> </ul> </li> </ul> </li> </ul>	<p>Set the printer to restart when an error occurs.</p>
<p><b>Note:</b> An asterisk (*) next to a value indicates the factory default setting.</p>	

Menu item	Description
<b>Error Prevention</b> Auto Reboot Max Auto Reboots 1–20 (2*)	Set the number of automatic reboots that the printer can perform.
<b>Error Prevention</b> Auto Reboot Auto Reboot Window 1–525600 seconds (720*)	Set the time before the printer performs an automatic reboot.
<b>Error Prevention</b> Auto Reboot Auto Reboot Counter	Show a read-only information of the reboot counter.
<b>Error Prevention</b> Auto Reboot Reset Auto Reboot Counter Cancel Continue	Reset Auto Reboot Counter.
<b>Error Prevention</b> Display Short Paper Error On Auto-clear*	Set the printer to show a message when a short paper error occurs.  <b>Note:</b> Short paper refers to the size of the paper loaded.
<b>Error Prevention</b> Page Protect Off* On	Set the printer to process the entire page into the memory before printing it.
<b>Jam Content Recovery</b> Jam Recovery Off On Auto*	Set the printer to reprint jammed pages.
<b>Jam Content Recovery</b> Scanner Jam Recovery Job level Page level*	Specify how to restart a scan job after resolving a paper jam.

**Note:** An asterisk (\*) next to a value indicates the factory default setting.

## Power Management

Menu item	Description
<b>Sleep Mode Profile</b> Print from Sleep Mode Stay awake after printing Enter Sleep Mode after printing*	Set the printer to stay in Ready mode or return to Sleep mode after printing.
<b>Timeouts</b> Sleep Mode 1–120 minutes (15*)	Set the idle time before the printer begins operating in Sleep mode.
<b>Timeouts</b> Hibernate Timeout Disabled 1 hour 2 hours 3 hours 6 hours 1 day 2 days 3 days* 1 week 2 weeks 1 month	Set the time before the printer turns off.
<b>Timeouts</b> Hibernate Timeout on Connection Hibernate Do Not Hibernate*	Set Hibernate Timeout to turn off the printer while an active Ethernet connection exists.
<b>Schedule Power Modes</b> Schedules Add New Schedule	Schedule the printer when to enter Sleep or Hibernate mode.
<b>Note:</b> An asterisk (*) next to a value indicates the factory default setting.	

## Accessibility

Menu item	Description
<b>Duplicate Key Strike Interval</b> 0–5 seconds (0*)	Set the interval during which the printer ignores duplicate key presses on an attached keyboard.
<b>Key Repeat Initial Delay</b> 0.25–5 seconds (1*)	Set the initial length of delay before a repeating key starts repeating. <b>Note:</b> Appears only when a keyboard is attached to the printer.
<b>Key Repeat Rate</b> 0.5–30 (30*)	Set the number of presses per second for a repeating key. <b>Note:</b> Appears only when a keyboard is attached to the printer.
<b>Note:</b> An asterisk (*) next to a value indicates the factory default setting.	



Menu item	Description
<b>Prolong Screen Timeout</b> Off* On	Let the user remain in the same location and reset the Screen Timeout timer when it expires instead of returning to the home screen.
<b>Note:</b> An asterisk (*) next to a value indicates the factory default setting.	

## Restore Factory Defaults

Menu item	Description
<b>Restore Settings</b> Restore all settings Restore printer settings Restore network settings Restore fax settings Restore app settings	Restore the printer factory default settings. <b>Note:</b> The default value is the value selected during the initial setup.

## Maintenance

### Configuration Menu

Menu item	Description
<b>USB Configuration</b> USB PnP 1* 2	Change the USB driver mode of the printer to improve its compatibility with a personal computer.
<b>USB Configuration</b> USB Scan to Local On* Off	Set whether the USB device driver enumerates as a USB Simple device (single interface) or as a USB Composite device (multiple interfaces).
<b>USB Configuration</b> USB Speed Full Auto*	Set the USB port to run at full speed and disable its high-speed capabilities.
<b>Tray Configuration</b> Tray Linking Automatic* Off	Set the printer to link the trays that have the same paper type and paper size settings.
<b>Tray Configuration</b> Show Tray Insert Message Off Only for unknown sizes* Always	Show the <b>Tray Insert</b> message.
<b>Note:</b> An asterisk (*) next to a value indicates the factory default setting.	

Menu item	Description
<b>Tray Configuration</b> A5 Loading Short Edge* Long Edge	Specify the page orientation when loading A5 paper size.
<b>Tray Configuration</b> Paper Prompts Auto* Multipurpose Feeder Manual Paper	Set the paper source that the user fills when a prompt to load paper appears.
<b>Tray Configuration</b> Envelope Prompts Auto* Multipurpose Feeder Manual Envelope	Set the paper source that the user fills when a prompt to load envelope appears.
<b>Tray Configuration</b> Action for Prompts Prompt user Continue* Use current	Set the printer to resolve paper- or envelope-related change prompts.
<b>Reports</b> Menu Settings Page Event Log Event Log Summary HealthCheck Statistics	Print reports about printer menu settings, status, and event logs.
<b>Supply Usage And Counters</b> Clear Supply Usage History Reset Black Cartridge Counter Reset Maintenance Counter	Reset the supply page counter or view the total printed pages.
<b>Printer Emulations</b> PPDS Emulation Off* On	Set the printer to recognize and use the PPDS data stream.
<b>Printer Emulations</b> PS Emulation Off On*	Set the printer to recognize and use the PS data stream.
<b>Printer Emulations</b> Emulator Security Page Timeout 0–60 (60*)	Set the page timeout during emulation.

**Note:** An asterisk (\*) next to a value indicates the factory default setting.

Menu item	Description
<b>Printer Emulations</b> Emulator Security Reset Emulator After Job Off* On	Reset the emulator after a print job.
<b>Printer Emulations</b> Emulator Security Disable Printer Message Access On* Off	Disable access to the printer message during emulation.
<b>Fax Configuration</b> Fax Low Power Support Disable Sleep Permit Sleep Auto*	Set fax to enter Sleep mode whenever the printer determines that it should.
<b>Print Configuration</b> Font Sharpening 0–150 (24*)	Set a text point-size value below which the high-frequency screens are used when printing font data.
<b>Print Configuration</b> Print Density Disabled* 1–5 Copy Density Disabled* 1–5	Adjust the toner density when printing or copying documents.
<b>Device Operations</b> Quiet Mode Off* On	Set the printer to reduce the amount of noise that it makes when printing.  <b>Note:</b> Enabling this setting slows down the overall performance of the printer.
<b>Device Operations</b> Panel Menus Enable* Disable	Set the printer to show the menus on the control panel.  <b>Note:</b> This menu item appears only in the Embedded Web Server.
<b>Device Operations</b> Safe Mode Off* On	Set the printer to operate in a special mode, in which it attempts to continue offering as much functionality as possible, despite known issues.  For example, when set to On, and the duplex motor is nonfunctional, the printer performs one-sided printing of the documents even if the job is two-sided printing.
<b>Note:</b> An asterisk (*) next to a value indicates the factory default setting.	

Menu item	Description
<b>Device Operations</b> Minimum Copy Memory 80 MB* 100 MB	Set the minimum memory allocation for storing copy jobs.
<b>Device Operations</b> Clear Custom Status	Erase all custom messages.
<b>Device Operations</b> Clear all remotely-installed messages	Erase all remotely-installed messages.
<b>Device Operations</b> Automatically Display Error Screens On* Off	Show existing error messages on the display after the printer remains inactive on the home screen for a length of time equal to the Screen Timeout setting.
<b>Device Operations</b> Honor orientation on fast path copy On Off*	Enable the printer to use the orientation setting under the Copy menu when sending quick copy jobs.
<b>Scanner Configuration</b> Scanner Manual Registration Print Quick Test	Print a Quick Test target page. <b>Note:</b> Make sure that the margin spacing on the target page is uniform all the way around the target. If it is not, then the printer margins must be reset.
<b>Scanner Configuration</b> Scanner Manual Registration Front ADF Registration Rear ADF Registration Flatbed Registration	Manually register the flatbed and ADF after replacing the ADF, scanner glass, or controller board.
<b>Scanner Configuration</b> Edge Erase Flatbed Edge Erase 0–6 (3*) ADF Edge Erase 0–6 (3*)	Set the size, in millimeters, of the no-print area around an ADF or flatbed scan job.
<b>Scanner Configuration</b> ADF Deskew ADF Mechanical Deskew Off On Auto*	Set the printer to perform ADF mechanical skew adjustment.
<b>Note:</b> An asterisk (*) next to a value indicates the factory default setting.	

Menu item	Description
<b>Scanner Configuration</b> Disable Scanner Enabled* Disabled ADF Disabled	Disable the scanner if it is not working properly.
<b>Scanner Configuration</b> Tiff Byte Order CPU Endianness* Little Endian Big Endian	Set the byte order of a TIFF-formatted scan output.
<b>Scanner Configuration</b> Exact Tiff Rows Per Strip On* Off	Set the RowsPerStrip tag value of a TIFF-formatted scan output.
<b>Note:</b> An asterisk (*) next to a value indicates the factory default setting.	

### Out of Service Erase

Menu item	Description
<b>Out of Service Erase</b> Memory Last Sanitized Hard Disk Last Sanitized	Show information on when the printer memory or hard disk was last sanitized.  <b>Note:</b> Hard Disk Last Sanitized appears only when a hard disk is installed.
<b>Out of Service Erase</b> Sanitize all information on nonvolatile memory Erase all printer and network settings Erase all apps and app settings Erase all shortcuts and shortcut settings Sanitize all information on hard disk Erase downloads (Erase all macros, fonts, PPOs, etc.) Erase buffered jobs Erase Held jobs	Clear all information on non-volatile memory and information on the hard disk.  <b>Note:</b> Sanitize all information on hard disk appears only when a hard disk is installed.

## Visible Home Screen Icons

Menu	Description
<b>Visible Home Screen Icons</b> Copy E-mail Fax Status/Supplies Job Queue Change Language Shortcut Center Address Book Bookmarks Held Jobs USB FTP Scan Profiles App Profiles Scan Center	Specify which icons to show on the home screen.

## About this Printer

Menu item	Description
<b>Asset Tag<sup>1</sup></b>	Describe the printer. The maximum length is 32 characters.
<b>Printer's Location<sup>1</sup></b>	Identify the printer location. The maximum length is 63 characters.
<b>Contact<sup>1</sup></b>	Personalize the printer name. The maximum length is 63 characters.
<b>Export Configuration File to USB<sup>2</sup></b>	Export configuration files to a flash drive.
<b>Export Compressed Logs to USB<sup>2</sup></b>	Export compressed log files to a flash drive.
<sup>1</sup> In some printer models, this menu item can be configured only from the Embedded Web Server. <sup>2</sup> This menu item appears only in some printer models.	

## Print

### Layout

Menu item	Description
<b>Sides</b> 1-Sided* 2-Sided	Specify whether to print on one side or both sides of the paper.
<b>Note:</b> An asterisk (*) next to a value indicates the factory default setting.	

Menu item	Description
<b>Flip Style</b> Long Edge* Short Edge	Determine which side of the paper is bound when performing two-sided printing.
<b>Blank Pages</b> Print Do Not Print*	Print blank pages that are included in a print job.
<b>Collate</b> Off (1,1,1,2,2,2) On (1,2,1,2,1,2)*	Keep the pages of a print job stacked in sequence, particularly when printing multiple copies of the job.
<b>Separator Sheets</b> None* Between Copies Between Jobs Between Pages	Insert blank separator sheets when printing.
<b>Separator Sheet Source</b> Tray [x] (1*) Multipurpose Feeder	Specify the paper source for the separator sheet.
<b>Pages per Side</b> Off* 2 pages per side 3 pages per side 4 pages per side 6 pages per side 9 pages per side 12 pages per side 16 pages per side	Print multiple page images on one side of a sheet of paper.
<b>Pages per Side Ordering</b> Horizontal* Reverse Horizontal Vertical Reverse Vertical	Specify the positioning of multiple page images when using the Pages per Side menu.
<b>Pages per Side Orientation</b> Auto* Landscape Portrait	Specify the orientation of multiple page images when using the Pages per Side menu.
<b>Pages per Side Border</b> None* Solid	Print a border around each page image when using the Pages per Side menu.
<b>Copies</b> 1–9999 (1*)	Specify the number of copies for each print job.
<b>Note:</b> An asterisk (*) next to a value indicates the factory default setting.	

Menu item	Description
<b>Print Area</b> Normal* Fit to page Whole Page	Set the printable area on a sheet of paper.
<b>Note:</b> An asterisk (*) next to a value indicates the factory default setting.	

## Setup

Menu item	Description
<b>Printer Language</b> PCL Emulation* PS Emulation	Set the printer language. <b>Note:</b> Setting a printer language default does not prevent a software program from sending print jobs that use another printer language.
<b>Resource Save</b> Off* On	Determine what the printer does with downloaded resources, such as fonts and macros, when it receives a job that requires more than the available memory. <b>Notes:</b> <ul style="list-style-type: none"> <li>• When set to Off, the printer retains downloaded resources only until memory is needed. Resources associated with the inactive printer language are deleted.</li> <li>• When set to On, the printer preserves all the permanent downloaded resources across all language switches. When necessary, the printer shows memory full messages instead of deleting permanent resources.</li> </ul>
<b>Print All Order</b> Alphabetical* Newest First Oldest First	Specify the order when you choose to print all held and confidential jobs.
<b>Note:</b> An asterisk (*) next to a value indicates the factory default setting.	

## Quality

Menu item	Description
<b>Print Resolution</b> 300 dpi 600 dpi* 1200 dpi 1200 Image Q 2400 Image Q	Set the resolution for the text and images on the printed output. <b>Note:</b> Resolution is determined in dots per inch or image quality.
<b>Note:</b> An asterisk (*) next to a value indicates the factory default setting.	



Menu item	Description
<b>Pixel Boost</b> Off* Fonts Horizontally Vertically Both directions Isolated	Enable more pixels to print in clusters for clarity, in order to enhance text and images.
<b>Toner Darkness</b> 1–10 (8*)	Determine the lightness or darkness of text images.
<b>Halftone</b> Normal* Detail	Enhance the printed output to have smoother lines with sharper edges.
<b>Brightness</b> -6 to 6 (0*)	Adjust the brightness of the printed output.
<b>Contrast</b> 0 to 5 (0*)	Adjust the contrast of the printed output.
<b>Gray Correction</b> Auto* Off	Adjust the contrast enhancement applied to images.
<b>Note:</b> An asterisk (*) next to a value indicates the factory default setting.	

## Job Accounting

Menu item	Description
<b>Job Accounting</b> Off* On	Set the printer to create a log of the print jobs that it receives. <b>Note:</b> This menu item appears only when a flash memory or hard disk is installed.
<b>Accounting Log Frequency</b> Daily Weekly Monthly*	Specify how often the printer creates a log file.
<b>Log Action at End of Frequency</b> None* E-mail Current Log E-mail & Delete Current Log Post Current Log Post & Delete Current Log	Specify how the printer responds when the frequency threshold expires. <b>Note:</b> The value defined in Accounting Log Frequency determines when this action is triggered.
<b>Note:</b> An asterisk (*) next to a value indicates the factory default setting.	

Menu item	Description
<b>Log Action at Near Full</b> None* E-mail Current Log E-mail & Delete Current Log E-mail & Delete Oldest Log Post Current Log Post & Delete Current Log Post & Delete Oldest Log Delete Current Log Delete Oldest Log Delete All But Current Delete All Logs	Specify how the printer responds when the hard disk is nearly full.
<b>Log Action at Full</b> None* E-mail & Delete Current Log E-mail & Delete Oldest Log Post & Delete Current Log Post & Delete Oldest Log Delete Current Log Delete Oldest Log Delete All But Current Delete All Logs	Specify how the printer responds when hard disk usage reaches the maximum limit (100MB).
<b>URL to Post Log</b>	Specify where the printer posts job accounting logs.
<b>E-mail Address to Send Logs</b>	Specify the e-mail address to which the printer sends job accounting logs.
<b>Log File Prefix</b>	Specify the prefix for the log files.  <b>Note:</b> The current host name defined in the TCP/IP menu is used as the default log file prefix.
<b>Note:</b> An asterisk (*) next to a value indicates the factory default setting.	

## XPS

Menu item	Description
<b>Print Error Pages</b> Off* On	Print a test page that contains information on errors, including XML markup errors.
<b>Minimum Line Width</b> 1–30 (2*)	Set the minimum stroke width.  <b>Notes:</b> <ul style="list-style-type: none"> <li>Jobs printed in 1200 dpi use the value directly.</li> <li>Jobs printed in 4800 CQ use half the value.</li> </ul>
<b>Note:</b> An asterisk (*) next to a value indicates the factory default setting.	

## PDF

Menu item	Description
<b>Scale To Fit</b> Yes No*	Scale the page content to fit the selected paper size.
<b>Annotations</b> Print Do Not Print*	Specify whether to print annotations in the PDF.
<b>Print PDF Error</b> Off On*	Enable the printing of PDF error.
<b>Note:</b> An asterisk (*) next to a value indicates the factory default setting.	

## PostScript

Menu item	Description
<b>Print PS Error</b> On Off*	Print a test page that contains the PostScript error.
<b>Minimum Line Width</b> 1–30 (2*)	Set the minimum stroke width of any job printed in 1200 dpi.
<b>Lock PS Startup Mode</b> On Off*	Disable the SysStart file.
<b>Font Priority</b> Resident* Flash/Disk	Establish the font search order. <b>Notes:</b> <ul style="list-style-type: none"> <li>Resident sets the printer to search its memory for the requested font before searching the flash memory.</li> <li>Flash/Disk sets the printer to search the flash memory for the requested font before searching the printer memory.</li> <li>This menu item appears only when a flash memory is installed.</li> </ul>
<b>Wait Timeout</b> Disabled 15–65535 (40*)	Set the printer to wait for additional data before canceling a print job.
<b>Note:</b> An asterisk (*) next to a value indicates the factory default setting.	

**PCL**

Menu item	Description
<b>Font Source</b> Resident* All	Choose the source which contains the default font selection.
<b>Font Name</b> [List of available fonts]	Select a font from the specified font source.
<b>Symbol Set</b> [List of available symbol set]	Specify the symbol set for each font name.  <b>Note:</b> A symbol set is a set of alphabetic and numeric characters, punctuation, and special symbols. Symbol sets support the different languages or specific programs such as math symbols for scientific text.
<b>Pitch</b> 0.08–100 (10*)	Specify the font pitch for scalable monospaced fonts.  <b>Note:</b> Pitch refers to the number of fixed-space characters in a horizontal inch of type.
<b>Orientation</b> Portrait* Landscape	Specify the orientation of text and graphics on the page.
<b>Lines per Page</b> 1–255	Specify the number of lines of text for each page printed through the PCL® datastream.  <b>Notes:</b> <ul style="list-style-type: none"> <li>• This menu item activates vertical escapement that causes the selected number of requested lines to print between the default margins of the page.</li> <li>• 60 is the U.S. factory default setting. 64 is the international factory default setting.</li> </ul>
<b>PCL5 Minimum Line Width</b> 1–30 (2*)	Set the initial minimum stroke width.  <b>Notes:</b>
<b>PCLXL Minimum Line Width</b> 1–30 (2*)	<ul style="list-style-type: none"> <li>• Jobs printed in 1200 dpi use the value directly.</li> <li>• Jobs printed in 4800CQ use half the value.</li> </ul>
<b>A4 Width</b> 198 mm* 203 mm	Set the width of the logical page on A4-size paper.  <b>Note:</b> Logical page is the space on the physical page where data is printed.
<b>Auto CR after LF</b> On Off*	Set the printer to perform a carriage return after a line feed control command.  <b>Note:</b> Carriage return is a mechanism that commands the printer to move the position of the cursor to the first position on the same line.
<b>Auto LF after CR</b> On Off*	Set the printer to perform a line feed after a carriage return control command.
<b>Note:</b> An asterisk (*) next to a value indicates the factory default setting.	

Menu item	Description
<b>Tray Renumber</b> Assign MP Feeder Off* None 0–201 Assign Tray [x] Off* None 0–201 Assign Manual Paper Off* None 0–201 Assign Manual Envelope Off* None 0–201	Configure the printer to work with print drivers or applications that use different source assignments for the paper source.
<b>Tray Renumber</b> View Factory Defaults	Show the factory default setting assigned for each paper source.
<b>Tray Renumber</b> Restore Defaults	Return all tray assignments to factory default values.
<b>Print Timeout</b> Disabled 1–255 (90*)	Set the printer to end a print job after it has been idle for the specified amount of time in seconds.
<b>Note:</b> An asterisk (*) next to a value indicates the factory default setting.	

## HTML

Menu item	Description
<b>Font Name</b> [List of fonts] (Times*)	Set the font to use for HTML documents.
<b>Font Size</b> 1–255 (12*)	Set the font size to use for HTML documents.
<b>Scale</b> 1–400% (100*)	Scale HTML documents.
<b>Orientation</b> Portrait* Landscape	Set the page orientation for HTML documents.
<b>Margin Size</b> 8–255 mm (19*)	Set the page margin for HTML documents.
<b>Note:</b> An asterisk (*) next to a value indicates the factory default setting.	

Menu item	Description
<b>Backgrounds</b> Do Not Print Print*	Print background information or graphics for HTML documents.
<b>Note:</b> An asterisk (*) next to a value indicates the factory default setting.	

## Image

Menu item	Description
<b>Auto Fit</b> On Off*	Select the best available paper size and orientation setting for an image. <b>Note:</b> When set to On, this menu item overrides the scaling and orientation settings for the image.
<b>Invert</b> Off* On	Invert bitonal monochrome images. <b>Note:</b> This menu item does not apply to GIF or JPEG image formats.
<b>Scaling</b> Anchor Top Left Best Fit* Anchor Center Fit Height/Width Fit Height Fit Width	Adjust the image to fit the printable area. <b>Note:</b> When Auto Fit is set to On, Scaling is automatically set to Best Fit.
<b>Orientation</b> Portrait* Landscape Reverse Portrait Reverse Landscape	Specify the orientation of text and graphics on the page.
<b>Note:</b> An asterisk (*) next to a value indicates the factory default setting.	

## Paper

### Tray Configuration

Menu item	Description
<b>Default Source</b> Tray [x] (1*) Multipurpose Feeder Manual Paper Manual Envelope	Set the paper source for all print jobs.
<b>Note:</b> An asterisk (*) next to a value indicates the factory default setting.	

Menu item	Description
<b>Paper Size/Type</b> Tray [x] Multipurpose Feeder Manual Paper Manual Envelope	Specify the paper size or paper type loaded in each paper source.
<b>Substitute Size</b> Off Statement/A5 Letter/A4 All Listed*	Set the printer to substitute a specified paper size if the requested size is not loaded in any paper source.  <b>Notes:</b> <ul style="list-style-type: none"> <li>• Off prompts the user to load the required paper size.</li> <li>• Statement/A5 prints A5-size document on statement when loading statement and statement-size jobs on A5 paper size when loading A5.</li> <li>• Letter/A4 prints A4-size document on letter when loading letter and letter-size jobs on A4 paper size when loading letter.</li> <li>• All Listed substitutes Letter/A4.</li> </ul>
<b>Configure MP</b> Cassette* Manual First	Determine the behavior of the multipurpose feeder.  <b>Notes:</b> <ul style="list-style-type: none"> <li>• Cassette configures the multipurpose feeder as the automatic paper source.</li> <li>• Manual sets the multipurpose feeder only for manual-feed print jobs.</li> <li>• First configures the multipurpose feeder as the primary paper source.</li> </ul>
<b>Note:</b> An asterisk (*) next to a value indicates the factory default setting.	

## Media Configuration menu

### Universal Setup

Menu item	Description
<b>Units of Measure</b> Inches Millimeters	Specify the unit of measurement for the universal paper.  <b>Note:</b> Inches is the U.S. factory default setting. Millimeters is the international factory default setting.
<b>Portrait Width</b> 3–52 inches (8.50*) 76–1321 mm (216*)	Set the portrait width of the universal paper.
<b>Portrait Height</b> 3–52 inches (14*) 76–1321 mm (356*)	Set the portrait height of the universal paper.
<b>Feed Direction</b> Short Edge* Long Edge	Set the printer to pick paper from the short edge or long edge direction.  <b>Note:</b> Long Edge appears only when the longest edge is shorter than the maximum width supported.
<b>Note:</b> An asterisk (*) next to a value indicates the factory default setting.	

## Custom Scan Sizes

Menu item	Description
<b>Custom Scan Size [x]</b> Scan Size Name Width 1–8.50 inches (8.50*) 25–216 mm (216*) Height 1–14 inches (14*) 25–356 mm (297*) Orientation Portrait* Landscape 2 scans per side Off* On	Assign a scan size name and configure the scan settings.

## Media Types

Menu item	Description
Plain	Specify the texture and weight of the paper loaded.
Card Stock	Select from the following options:
Transparency	Paper Texture
Recycled	Smooth
Labels	Normal*
Bond	Rough
Envelope	Paper Weight
Rough Envelope	Light
Letterhead	Normal*
Preprinted	Heavy
Colored Paper	
Light	
Heavy	
Rough/Cotton	
Custom Type [x]	

**Note:** An asterisk (\*) next to a value indicates the factory default setting.



# Copy

## Copy Defaults

Menu item	Description
<b>Content Type</b> Text Text/Photo* Photo Graphics	Improve the output result based on the content of the original document.
<b>Content Source</b> Black and White Laser* Color Laser Inkjet Photo/Film Magazine Newspaper Press Other	Improve the output result based on the source of the original document.
<b>Sides</b> 1 sided to 1 sided* 1 sided to 2 sided 2 sided to 1 sided 2 sided to 2 sided	Specify the scanning behavior based on the original document.
<b>Separator Sheets</b> None* Between Copies Between Jobs Between Pages	Specify whether to insert blank separator sheets when printing.
<b>Separator Sheet Source</b> Tray [x] (1*) Multipurpose Feeder	Specify the paper source for the separator sheet.
<b>Pages per Side</b> Off* 2 Portrait pages 4 Portrait pages 2 Landscape pages 4 Landscape pages	Specify the number of page images to print on one side of a sheet of paper.
<b>Print Page Borders</b> Off* On	Place a border around each image when printing multiple pages on a single page.

**Note:** An asterisk (\*) next to a value indicates the factory default setting.

Menu item	Description
<b>Collate</b> Off [1,1,1,2,2,2] On [1,2,1,2,1,2]*	Print multiple copies in sequence.
<b>“Copy from” Size</b>	Set the paper size of the original document. <b>Note:</b> Letter is the U.S. factory default setting. A4 is the international factory default setting.
<b>“Copy to” Source</b> Tray [x] (1*) Multipurpose Feeder Auto Size Match	Specify the paper source for the copy job.
<b>Darkness</b> 1 to 9 (5*)	Adjust the darkness of the scanned image.
<b>Number of Copies</b> 1–9999 (1*)	Specify the number of copies.
<b>Header/Footer</b> Left Header Middle Header Right Header Left Footer Middle Footer Right Footer	Specify the header or footer information on the scanned image.
<b>Overlay</b> Confidential Copy Draft Urgent Custom Off*	Specify the overlay text to print on each copy.
<b>Custom overlay</b>	Type the text for the Custom choice in Overlay menu.
<b>Note:</b> An asterisk (*) next to a value indicates the factory default setting.	

### Advanced Imaging

Menu item	Description
<b>Color Dropout</b> Color Dropout (None*) Default Red Threshold (128*) Default Green Threshold (128*) Default Blue Threshold (128*)	Specify which color to drop during scanning, and adjust the dropout setting for that color.
<b>Note:</b> An asterisk (*) next to a value indicates the factory default setting.	

Menu item	Description
<b>Contrast</b> Best for content* 0–5	Specify the contrast for the scanned image.
<b>Background Removal</b> Background Detection (Content-based*) Level (0*)	Remove the background color or image noise from the original document.  <b>Notes:</b> <ul style="list-style-type: none"> <li>• Content-based removes the background color from the original document .</li> <li>• Fixed removes image noise from a photo.</li> </ul>
<b>Auto Center</b> Off* On	Align the content at the center of the page.
<b>Mirror Image</b> Off* On	Create a mirror image of the original document.
<b>Negative Image</b> Off* On	Create a negative image of the original document.
<b>Shadow Detail</b> -4 to 4 (0*)	Adjust the shadow detail in the original document.
<b>Scan Edge to Edge</b> Off* On	Scan the original document from edge to edge.
<b>Sharpness</b> 1–5 (3*)	Adjust the sharpness of the scanned image.
<b>Note:</b> An asterisk (*) next to a value indicates the factory default setting.	

**Admin Controls**

Menu item	Description
<b>Transparency Separators</b> Off On*	Insert a blank sheet between transparencies.
<b>Allow Priority Copies</b> Off On*	Interrupt a print job to make copies.
<b>Custom Job Scanning</b> Off* On	Set the printer to scan the first set of original documents using the specified settings, and then scan the next set with the same or different settings.  <b>Note:</b> This menu item appears only when a hard disk is installed.
<b>Note:</b> An asterisk (*) next to a value indicates the factory default setting.	

Menu item	Description
<b>Allow Save as Shortcut</b> Off On*	Save copy settings as a shortcut.
<b>Sample copy</b>	Print a sample copy to check the quality before printing the remaining copies.
<b>Note:</b> An asterisk (*) next to a value indicates the factory default setting.	

## Fax

### Fax Mode

Menu item	Description
<b>Fax Mode</b> Fax* Fax Server Disabled	Select a fax mode.
<b>Note:</b> An asterisk (*) next to a value indicates the factory default setting.	

### Fax Setup

Menu item	Description
<b>General Fax Settings</b> Fax Name Fax Number Fax ID (Fax Number*) Enable Manual Fax (Off*) Memory Use (Equal*) Cancel Faxes (Allow*) Fax Number Masking (Off*) Digits to Mask Enable Line Connected Detection (On*) Enable Line In Wrong Jack Detection (On*) Enable Extension In Use Support (On*) Optimize Fax Compatibility Fax Transport (Analog*)	Configure the general fax settings.
<b>Note:</b> An asterisk (*) next to a value indicates the factory default setting.	

Menu item	Description
<p><b>Fax Send Settings</b></p> <ul style="list-style-type: none"> <li>Resolution (Standard*)</li> <li>Original Size (Mixed Sizes*)</li> <li>Orientation (Portrait*)</li> <li>Sides (Off*)</li> <li>Content Type (Text*)</li> <li>Content Source (Color Laser*)</li> <li>Darkness (5*)</li> <li>Behind a PABX (Off*)</li> <li>Dial Mode (Tone*)</li> <li>Advanced Imaging                             <ul style="list-style-type: none"> <li>Color Balance</li> <li>Color Dropout</li> <li>Contrast (Best for Content*)</li> <li>Background Removal                                     <ul style="list-style-type: none"> <li>Background Detection (Content-based*)</li> <li>Level (0*)</li> </ul> </li> </ul> </li> <li>Mirror Image (Off*)</li> <li>Negative Image (Off*)</li> <li>Shadow Detail (0*)</li> <li>Scan Edge to Edge (Off*)</li> <li>Sharpness (3*)</li> <li>Temperature (0*)</li> <li>Admin Controls                             <ul style="list-style-type: none"> <li>Automatic Redial (5*)</li> <li>Redial Frequency (3 minutes*)</li> <li>Enable ECM (On*)</li> <li>Enable Fax Scans (On*)</li> <li>Driver to Fax (Off*)</li> <li>Allow Save as Shortcut (On*)</li> <li>Max Speed (33600*)</li> <li>Custom Job Scanning (Off*)</li> <li>Scan Preview (Off*)</li> <li>Enable Color Fax Scans (Off by Default*)</li> <li>Auto Convert Color Faxes to Mono Faxes (On*)</li> <li>Confirm Fax Number (Off*)</li> <li>Dial Prefix</li> <li>Dialing Prefix Rules</li> </ul> </li> </ul>	<p>Configure the fax send settings.</p> <p><b>Note:</b> Custom Job Scanning and Scan Preview appear only when a hard disk is installed.</p>
<p><b>Note:</b> An asterisk (*) next to a value indicates the factory default setting.</p>	

Menu item	Description
<p><b>Fax Receive Settings</b></p> <ul style="list-style-type: none"> <li>Rings to Answer (3*)</li> <li>Auto Reduction (Off*)</li> <li>Paper Source (Auto*)</li> <li>Sides (Off*)</li> <li>Separator Sheets (None*)</li> <li>Separator Sheet Source(Tray 1*)</li> <li>Output Bin(Standard Bin*)</li> <li>Fax Footer (Off*)</li> <li>Fax Footer Time Stamp (Receive*)</li> <li>Holding Faxes               <ul style="list-style-type: none"> <li>Held Fax Mode (Off*)</li> </ul> </li> <li>Admin Controls               <ul style="list-style-type: none"> <li>Enable Fax Receive (On*)</li> <li>Enable Color Fax Receive (On*)</li> <li>Enable Caller ID (On*)</li> <li>Block No Name Fax (Off*)</li> <li>Banned Fax List</li> <li>Answer On (All Rings*)</li> <li>Auto Answer (On*)</li> <li>Manual Answer Code (*9*)</li> <li>Fax Forwarding (Print*)</li> <li>Forward to</li> <li>Confirmation E-mail</li> <li>Max Speed (33600*)</li> </ul> </li> </ul>	<p>Configure the fax receive settings.</p>
<p><b>Fax Cover Page</b></p> <ul style="list-style-type: none"> <li>Fax Cover Page (Off by Default*)</li> <li>Include To field (Off*)</li> <li>Include From field (Off*)</li> <li>Include Message field (Off*)</li> <li>Include Logo (Off*)</li> <li>Include Footer [x]</li> </ul>	<p>Configure the fax cover page settings.</p>
<p><b>Note:</b> An asterisk (*) next to a value indicates the factory default setting.</p>	

Menu item	Description
<p><b>Fax Log Settings</b></p> <ul style="list-style-type: none"> <li>Transmission Log Frequency (Always*)</li> <li>Transmission Log Action                             <ul style="list-style-type: none"> <li>Print (On*)</li> <li>E-mail (Off*)</li> </ul> </li> <li>Receive Error Log (Print Never*)</li> <li>Auto Print Logs (On*)</li> <li>Log Paper Source (Tray 1*)</li> <li>Logs Display (Remote Fax Name*)</li> <li>Enable Job Log (On*)</li> <li>Enable Call Log (On*)</li> <li>Log Output Bin (Standard Bin*)</li> </ul>	<p>Configure the fax log settings.</p>
<p><b>Speaker Settings</b></p> <ul style="list-style-type: none"> <li>Speaker Mode (Always Off*)</li> <li>Speaker Volume (Low*)</li> <li>Ringer Volume (Off*)</li> </ul>	<p>Set the speaker mode and volume for incoming or outgoing fax.</p>
<p><b>Note:</b> An asterisk (*) next to a value indicates the factory default setting.</p>	

## Fax Server Setup

Menu item	Description
<p><b>General Fax Settings</b></p> <ul style="list-style-type: none"> <li>To Format</li> <li>Reply Address</li> <li>Subject:</li> <li>Message:</li> <li>Enable analog receive (Off*)</li> </ul>	<p>Configure the general fax settings.</p>
<p><b>Note:</b> An asterisk (*) next to a value indicates the factory default setting.</p>	

Menu item	Description
<b>Fax Server E-mail Settings</b> Use E-mail SMTP Server (Off*) Primary SMTP Gateway Primary SMTP Gateway Port Secondary SMTP Gateway Secondary SMTP Gateway Port SMTP Timeout (30 seconds*) Reply Address Use SSL/TLS (Disabled*) Required Trusted Certificate (On*) SMTP Server Authentication (No authentication required*) Device-Initiated E-mail (None*) User-Initiated E-mail (None*) Use Active Directory Device Credentials (Off*) Device Userid Device Password Kerberos 5 REALM NTLM Domain Disable "SMTP server not set up" error (Off*)	Configure the fax server e-mail settings.
<b>Fax Server Scan Settings</b> Image Format (PDF (.pdf)*) Content Type (Text*) Content Source (Color Laser*) Fax Resolution (Standard*) Sides (Off*) Darkness (5*) Orientation (Portrait*) Original Size (Mixed Sizes*) Use Multi-Page TIFF (On*)	Configure the fax server scan settings.

**Note:** An asterisk (\*) next to a value indicates the factory default setting.

## E-mail

### E-mail Setup

Menu item	Description
<b>Primary SMTP Gateway</b>	Type the IP address or host name of the primary SMTP server for sending e-mail.
<b>Primary SMTP Gateway Port</b> 1-65535 (25*)	Enter the port number of the primary SMTP server.

**Note:** An asterisk (\*) next to a value indicates the factory default setting.



Menu item	Description
<b>Secondary SMTP Gateway</b>	Type the server IP address or host name of your secondary or backup SMTP server.
<b>Secondary SMTP Gateway Port</b> 1–65535 (25*)	Enter the server port number of your secondary or backup SMTP server.
<b>SMTP Timeout</b> 5–30 seconds (30*)	Set the time before the printer times out if the SMTP server does not respond.
<b>Reply Address</b>	Specify a reply address in the e-mail.
<b>Always use SMTP default Reply Address</b> On Off*	Always use the default reply address in the SMTP server.
<b>Use SSL/TLS</b> Disabled* Negotiate Required	Specify whether to send e-mail using an encrypted link.
<b>Require Trusted Certificate</b> Off On*	Require a trusted certificate when accessing the SMTP server.
<b>SMTP Server Authentication</b> No authentication required* Login / Plain NTLM CRAM-MD5 Digest-MD5 Kerberos 5	Set the authentication type for the SMTP server.
<b>Device-Initiated E-mail</b> None* Use Device SMTP Credentials	Specify whether credentials are required for device-initiated e-mail.
<b>User-Initiated E-mail</b> None* Use Device SMTP Credentials Use Session User ID and Password Use Session E-mail address and Password Prompt user	Specify whether credentials are required for user-initiated e-mail.
<b>Use Active Directory Device Credentials</b> Off* On	Specify whether credentials are required for user-initiated e-mail.
<b>Device Userid</b>	Specify the user ID and password to connect to the SMTP server.
<b>Device Password</b>	
<b>Kerberos 5 REALM</b>	Specify the realm for the Kerberos 5 authentication protocol.
<b>Note:</b> An asterisk (*) next to a value indicates the factory default setting.	

Menu item	Description
<b>NTLM Domain</b>	Specify the domain name for the NTLM security protocol.
<b>Note:</b> An asterisk (*) next to a value indicates the factory default setting.	

## E-mail Defaults

Menu item	Description
<b>Subject:</b>	Specify the e-mail subject and message.
<b>Message:</b>	
<b>File Name</b>	Specify the filename for the scanned document.
<b>Format</b> JPEG (.jpg) PDF (.pdf)* TIFF (.tif) XPS (.xps)	Specify the file format of the scanned document.
<b>PDF Settings</b> PDF Version (1.5*) Archival Version (A-1a*) Highly Compressed (Off*) Secure (Off*) Archival (PDF/A) (Off*)	Configure the PDF settings of the scanned document. <b>Notes:</b> <ul style="list-style-type: none"> <li>• Archival Version and Archival (PDF/A) are supported only when PDF Version is set to 1.4.</li> <li>• Highly Compressed appears only when a hard disk is installed.</li> </ul>
<b>Content Type</b> Text Text/Photo* Photo Graphics	Improve the output result based on the content type of the original document.
<b>Content Source</b> Black and White Laser Color Laser* Inkjet Photo/Film Magazine Newspaper Press Other	Improve the output result based on the content source of the original document.
<b>Color</b> Black and White Gray Color* Auto	Set the printer to capture file content in color or in mono.
<b>Note:</b> An asterisk (*) next to a value indicates the factory default setting.	

Menu item	Description
<b>Resolution</b> 75 dpi 150 dpi* 200 dpi 300 dpi 400 dpi 600 dpi	Set the resolution of the scanned image.
<b>Darkness</b> 1–9 (5*)	Adjust the darkness of the scanned image.
<b>Orientation</b> Portrait* Landscape	Specify the orientation of the original document.
<b>Original Size</b> Mixed Sizes*	Set the paper size of the original document.
<b>Sides</b> Off* Short Edge Long Edge	Specify the orientation of the original document when scanning on both sides of the document.
<b>Note:</b> An asterisk (*) next to a value indicates the factory default setting.	

### Advanced Imaging

Menu item	Description
<b>Color Balance</b> Cyan (0*) Magenta (0*) Yellow (0*)	Adjust the color intensity for cyan, magenta, and yellow.
<b>Color Dropout</b> Color Dropout (None*) Default Red Threshold (128*) Default Green Threshold (128*) Default Blue Threshold (128*)	Specify which color to drop during scanning, and adjust the dropout setting for that color.
<b>Auto Color Detect</b> Color Sensitivity (5*) Area Sensitivity (5*) E-mail Bit Depth (1 bit*)	Configure the auto color detection setting.
<b>JPEG Quality</b> Best for content* 5–95	Set the JPEG quality of the scanned image.
<b>Note:</b> An asterisk (*) next to a value indicates the factory default setting.	

Menu item	Description
<b>Contrast</b> Best for content* 0–5	Specify the contrast for the scanned image.
<b>Background Removal</b> Background Detection (Content-based*) Level (0*)	Remove the background color or image noise from the original document.  <b>Notes:</b> <ul style="list-style-type: none"> <li>• Content-based removes the background color from the original document.</li> <li>• Fixed removes image noise from a photo.</li> </ul>
<b>Mirror Image</b> Off* On	Create a mirror image of the original document.
<b>Negative Image</b> Off* On	Create a negative image of the original document.
<b>Shadow Detail</b> -4 to 4 (0*)	Adjust the shadow detail in the scanned image.
<b>Scan Edge to Edge</b> Off* On	Scan the original document from edge to edge.
<b>Sharpness</b> 1–5 (3*)	Adjust the sharpness in the scanned image.
<b>Temperature</b> -4 to 4 (0*)	Generate a bluer or redder output of the original document.
<b>Blank Pages</b> Blank Page Removal (Remove*) Blank Page Sensitivity (5*)	Set the sensitivity of scans in relation to blank pages in the original document.
<b>Note:</b> An asterisk (*) next to a value indicates the factory default setting.	

**Admin Controls**

Menu item	Description
<b>Max E-mail Size</b> 0–65535 (0*)	Set the allowable file size for each e-mail.
<b>Size Error Message</b>	Specify an error message that the printer sends when an e-mail exceeds its allowable file size.  <b>Note:</b> You can type up to 1024 characters.
<b>Limit Destinations</b>	Limit sending of e-mail only to the specified list of domain name.  <b>Note:</b> Use a comma to separate each domain.
<b>Note:</b> An asterisk (*) next to a value indicates the factory default setting.	

Menu item	Description
<b>Send Me a Copy</b> Never appears* On by Default Off by Default Always On	Send a copy of the e-mail to yourself.
<b>Allow self e-mails only</b> Off* On	Set the printer to send e-mails to yourself only.
<b>Use cc:/bcc:</b> Off* On	Enable carbon copy and blind carbon copy in e-mail.
<b>Use Multi-Page TIFF</b> Off On*	Enable scanning of multiple TIFF images in one TIFF file.
<b>TIFF Compression</b> JPEG LZW*	Specify the compression type for TIFF files.
<b>Text Default</b> 5–95 (75*)	Set the text quality in the content being scanned.
<b>Text/Photo Default</b> 5–95 (75*)	Set the text and photo quality in the content being scanned.
<b>Photo Default</b> 5–95 (50*)	Set the photo quality of the content being scanned.
<b>Transmission Log</b> Print log Do Not Print Log* Print Only For Error	Print a transmission log for e-mail scans.
<b>Log Paper Source</b> Tray [x] (1*) Multipurpose Feeder	Specify the paper source for printing e-mail logs.
<b>Custom Job Scanning</b> Off* On	Set the printer to scan the first set of original documents using the specified settings, and then scan the next set with the same or different settings.  <b>Note:</b> This menu item appears only when a hard disk is installed.
<b>Scan Preview</b> Off On*	Show a scan preview of the original document.  <b>Note:</b> This menu item appears only when a hard disk is installed.
<b>Allow Save as Shortcut</b> Off On*	Save an e-mail address as a shortcut.
<b>Note:</b> An asterisk (*) next to a value indicates the factory default setting.	

Menu item	Description
<b>E-mail Images Sent As</b> Attachment* Web Link	Specify how to send the images that are included in the e-mail.
<b>Reset E-mail Information After Sending</b> Off On*	Reset the To, Subject, Message, and Filename fields to their default values after sending an e-mail.
<b>Note:</b> An asterisk (*) next to a value indicates the factory default setting.	

## Web Link Setup

Menu item	Description
<b>Server</b>	Set the printer to send e-mail as a web link.
<b>Login</b>	
<b>Password</b>	
<b>Path</b>	
<b>File Name</b>	
<b>Web Link</b>	

## FTP

### FTP Defaults

Menu item	Description
<b>Format</b> PDF (.pdf)* TIFF (.tif) JPEG (.jpg) XPS (.xps)	Specify the file format for the scanned image.
<b>PDF Settings</b> PDF Version (1.5*) Archival Version (A-1a*) Secure (Off*) Archival (PDF/A) (Off*)	Configure the PDF settings for the scanned image. <b>Note:</b> Archival Version and Archival (PDF/A) are supported only when PDF Version is set to 1.4.
<b>Content Type</b> Text Text/Photo* Graphics Photo	Improve the output result based on the content type of the original document.
<b>Note:</b> An asterisk (*) next to a value indicates the factory default setting.	

Menu item	Description
<b>Content Source</b> Black and White Laser Color Laser* Inkjet Photo/Film Magazine Newspaper Press Other	Improve the output result based on the source of the original document.
<b>Color</b> Black and White Gray Color* Auto	Set the printer to capture file content in color or in mono.
<b>Resolution</b> 75 dpi 150 dpi* 200 dpi 300 dpi 400 dpi 600 dpi	Set the resolution of the scanned image.
<b>Darkness</b> 1–9 (5*)	Adjust the darkness of the scanned image.
<b>Orientation</b> Portrait* Landscape	Specify the orientation of the original document.
<b>Original Size</b> Mixed Sizes*	Set the paper size of the original document.
<b>Sides</b> Off* Long Edge Short Edge	Specify the orientation when scanning on both sides of the document.
<b>File Name</b>	Specify the file name of the scanned image.
<b>Note:</b> An asterisk (*) next to a value indicates the factory default setting.	

**Advanced Imaging**

Menu item	Description
<b>Color Balance</b> Cyan - Red (0*) Magenta - Green (0*) Yellow - Blue (0*)	Adjust the color intensity for cyan, magenta, and yellow.
<b>Color Dropout</b> Color Dropout None* Red Green Blue Default Red Threshold 0–255 (128*) Default Green Threshold 0–255 (128*) Default Blue Threshold 0–255 (128*)	Specify which color to drop during scanning, and adjust the dropout setting for that color.
<b>Auto Color Detect</b> Color Sensitivity 1–9 (5*) Area Sensitivity 1–9 (5*)	Set the amount of color that the printer detects from the original document. <b>Note:</b> This menu item appears only when Color is set to Auto.
<b>JPEG Quality</b> Best for content* 5–95	Set the quality of a JPEG-format image. <b>Notes:</b> <ul style="list-style-type: none"> <li>• 5 reduces the file size, but lessens the image quality.</li> <li>• 90 provides the best image quality, but produces a large file size.</li> </ul>
<b>Contrast</b> Best for content* 0 1 2 3 4 5	Specify the contrast for the scanned image.
<b>Background Removal</b> Level (0*)	Remove the background color or image noise from the original document.
<b>Mirror Image</b> Off* On	Create a mirror image of the original document.
<b>Note:</b> An asterisk (*) next to a value indicates the factory default setting.	



Menu item	Description
<b>Negative Image</b> Off* On	Create a negative image of the original document.
<b>Shadow Detail</b> -4 to 4 (0*)	Adjust the amount of shadow detail visible on a scanned image.
<b>Scan Edge to Edge</b> Off* On	Allow edge-to-edge scanning of the original document.
<b>Sharpness</b> 1–5 (3*)	Adjust the sharpness of a scanned image.
<b>Temperature</b> -4 to 4 (0*)	Specify whether to generate a cooler or warmer output.
<b>Blank Pages</b> Blank Page Removal Blank Page Sensitivity	Specify whether to include blank pages.
<b>Note:</b> An asterisk (*) next to a value indicates the factory default setting.	

### Admin Controls

Menu item	Description
<b>Text Default</b> 5–95 (75*)	Set the quality of text on the scanned image.
<b>Text/Photo Default</b> 5–95 (75*)	Set the quality of text and photo on the scanned image.
<b>Photo Default</b> 5–95 (50*)	Set the quality of photo on the scanned image.
<b>Use Multi-Page TIFF</b> On* Off	Choose between single- and multiple-page TIFF files.
<b>TIFF Compression</b> LZW* JPEG	Set a compression option for TIFF files.
<b>Transmission Log</b> Print Log Do Not Print Log* Print Only For Error	Print a transmission log for FTP scans.
<b>Log Paper Source</b> Tray [x] (1*) Multipurpose Feeder	Specify the paper source for printing FTP logs.
<b>Note:</b> An asterisk (*) next to a value indicates the factory default setting.	

Menu item	Description
<b>FTP Bit Depth</b> 1 bit 8 bit*	Enable the Text/Photo mode to have smaller file sizes by using 1-bit image. <b>Note:</b> This menu item appears only when Color is set to Gray.
<b>Custom Job Scanning</b> Off* On	Turn on scanning of custom jobs by default. <b>Note:</b> This menu item appears only when a hard disk is installed.
<b>Scan Preview</b> Off On*	Show a preview of the scan on the display. <b>Note:</b> This menu item appears only when a hard disk is installed.
<b>Allow Save as Shortcut</b> Off On*	Save custom FTP settings as shortcuts.
<b>Note:</b> An asterisk (*) next to a value indicates the factory default setting.	

## Network/Ports

### Network Overview

Menu item	Description
<b>Active Adapter</b> Auto* Standard Network Wireless	Specify the type of the network connection. <b>Note:</b> Wireless is available only in printers connected to a wireless network.
<b>Network Status</b>	Show the connectivity status of the printer network.
<b>Display Network Status on Printer</b> Off On*	Show the network status on the display.
<b>Speed, Duplex</b>	Show the speed of the currently active network card.
<b>IPv4</b>	Show the IPv4 address.
<b>All IPv6 Addresses</b>	Show all IPv6 addresses.
<b>Reset Print Server</b>	Reset all active network connections to the printer. <b>Note:</b> This setting removes all network configuration settings.
<b>Network Job Timeout</b> Off On* (90 seconds)	Set the time before the printer cancels a network print job.
<b>Note:</b> An asterisk (*) next to a value indicates the factory default setting.	

Menu item	Description
<b>Banner Page</b> Off* On	Print a banner page.
<b>Scan to PC Port Range</b>	Specify a valid port range for printers that are behind a port blocking firewall.
<b>Enable Network Connections</b> Off On*	Enable the printer to connect to a network.
<b>Enable LLDP</b> Off* On	Enable Link Layer Discovery Protocol (LLDP) in the printer.
<b>Note:</b> An asterisk (*) next to a value indicates the factory default setting.	

## Wireless

**Note:** This menu is available only in printers connected to a wireless network.

Menu item	Description
<b>Setup On Printer Panel</b> Choose Network Add Wi-Fi Network Network Name Network Mode Infrastructure* Ad hoc Wireless Security Mode Disabled* WEP WPA2/WPA - Personal WPA2 - Personal	Configure the wireless connection using the control panel.
<b>Wi-Fi Protected Setup</b> Start Push Button Method Start PIN Method	Establish a wireless network and enable network security.  <b>Notes:</b> <ul style="list-style-type: none"> <li>• Start Push-Button Method connects the printer to a wireless network when buttons on both the printer and the access point (wireless router) are pressed within a given period of time.</li> <li>• Start PIN Method connects the printer to a wireless network when a PIN on the printer is entered into the wireless settings of the access point.</li> </ul>

Menu item	Description
<b>Network Mode</b> BSS Type Infrastructure* Ad hoc Preferred Channel Number Auto* 1–11	Specify the network mode.  <b>Note:</b> Preferred Channel Number only appears if BSS Type is set to Ad hoc.
<b>Enable Wi-Fi Direct</b> On Off*	Set the printer to connect directly to Wi-Fi devices.
<b>Compatibility</b> 802.11b/g/n (2.4GHz)* 802.11a/b/g/n/ac (2.4GHz/5GHz) 802.11a/n/ac (5GHz)	Specify the wireless standard for the wireless network.  <b>Note:</b> 802.11a/b/g/n and 802.11a/n are selectable only if the Enable Wi-Fi Direct setting is disabled.
<b>Wireless Security Mode</b> Disabled* WEP WPA2/WPA - Personal WPA2 - Personal 802.1x - RADIUS	Set the type of security for connecting the printer to wireless devices.
<b>WEP Authentication Mode</b> Auto* Open Shared	Set the type of Wireless Encryption Protocol (WEP) used by the printer.  <b>Note:</b> This menu item appears only if Wireless Security Mode is set to WEP.
<b>Set WEP Key</b>	Specify a WEP password for secure wireless connection.
<b>WPA2/WPA - Personal</b> AES	Enable wireless security through Wi-Fi Protected Access (WPA).  <b>Note:</b> This menu item appears only if the Wireless Security Mode is set to WPA2/WPA-Personal or WPA2-Personal.
<b>Set Pre-Shared Key</b>	Set the password for secure wireless connection.
<b>WPA2 - Personal</b> AES	Enable wireless security through WPA2.  <b>Note:</b> This menu item appears only if the Wireless Security Mode is set to WPA2/WPA-Personal or WPA2-Personal.
<b>802.1x Encryption Mode</b> WPA+ WPA2*	Enable wireless security through 802.1x standard.  <b>Note:</b> This menu item appears only if the Wireless Security Mode is set to 802.1x - Radius.

Menu item	Description
<b>IPv4</b> Enable DHCP On* Off Set Static IP Address IP Address Netmask Gateway	Enable and configure IPv4 settings in the printer.
<b>IPv6</b> Enable IPv6 On* Off Enable DHCPv6 On Off* Stateless Address Autoconfiguration On* Off DNS Server Address Manually Assigned IPv6 Address Manually Assigned IPv6 Router Address Prefix All IPv6 Addresses All IPv6 Router Addresses	Enable and configure IPv6 settings in the printer.
<b>Network Address</b> UAA LAA	View the network addresses.
<b>PCL Smartswitch</b> On* Off*	Set the printer to switch automatically to PCL emulation when a print job requires it, regardless of the default printer language. <b>Note:</b> If PCL SmartSwitch is off, then the printer does not examine incoming data and uses the default printer language specified in the Setup menu.
<b>PS Smartswitch</b> On* Off*	Set the printer to switch automatically to PS emulation when a print job requires it, regardless of the default printer language. <b>Note:</b> If PS SmartSwitch is off, then the printer does not examine incoming data and uses the default printer language specified in the Setup menu.
<b>Job Buffering</b> On Off*	Temporarily store print jobs in the printer hard disk before printing. <b>Note:</b> This menu item appears only when a hard disk is installed.
<b>Mac Binary PS</b> Auto* On	Set the printer to process Macintosh binary PostScript print jobs. <b>Note:</b> On processes raw binary PostScript print jobs.

## Ethernet

Menu item	Description
<b>Network Speed</b>	Show the speed of the active network adapter.
<b>IPv4</b> Enable DHCP (On*) Set Static IP Address	Configure the IPv4 settings.
<b>IPv6</b> Enable IPv6 (On*) Enable DHCPv6 (Off*) Stateless Address Autoconfiguration (On*) DNS Server Address Manually Assigned IPv6 Address Manually Assigned IPv6 Router Address Prefix (64*) All IPv6 Addresses All IPv6 Router Addresses	Configure the IPv6 settings.
<b>Network Address</b> UAA LAA	Specify the network address.
<b>PCL SmartSwitch</b> Off On*	Set the printer to switch automatically to PCL emulation when a print job requires it, regardless of the default printer language. <b>Note:</b> When this setting is disabled, the printer does not examine incoming data and uses the default printer language specified in the Setup menu.
<b>PS SmartSwitch</b> Off On*	Set the printer to switch automatically to PostScript emulation when a print job requires it, regardless of the default printer language. <b>Note:</b> When this setting is disabled, the printer does not examine incoming data and uses the default printer language specified in the Setup menu.
<b>Job Buffering</b> Off* On	Temporarily store jobs on the hard disk before printing. <b>Note:</b> This menu item appears only when a hard disk is installed.
<b>Mac Binary PS</b> Auto* On Off	Set the printer to process Macintosh binary PostScript print jobs. <b>Notes:</b> <ul style="list-style-type: none"> <li>• Auto processes print jobs from computers using either Windows or Macintosh operating systems.</li> <li>• Off filters PostScript print jobs using the standard protocol.</li> </ul>
<b>Energy Efficient Ethernet</b> On Off Auto*	Reduce power consumption when the printer does not receive data from the Ethernet network.
<b>Note:</b> An asterisk (*) next to a value indicates the factory default setting.	

## TCP/IP

**Note:** This menu appears only in network printers or printers attached to print servers.

Menu item	Description
<b>Set Hostname</b>	Set the current TCP/IP host name.
<b>Domain Name</b>	Set the domain name.
<b>Allow DHCP/BOOTP to update NTP server</b> On* Off	Allow the DHCP and BOOTP clients to update the NTP settings of the printer.
<b>Zero Configuration Name</b>	Specify a service name for the zero configuration network.
<b>Enable Auto IP</b> Off* On	Assign an IP address automatically.
<b>DNS Server Address</b>	Specify the current Domain Name System (DNS) server address.
<b>Backup DNS Address</b>	Specify the backup DNS server addresses.
<b>Backup DNS Address 2</b>	
<b>Backup DNS Address 3</b>	
<b>Domain Search Order</b>	Specify a list of domain names to locate the printer and its resources that reside in different domains on the network.
<b>Enable DDNS</b> Off* On	Update the Dynamic DNS settings.
<b>DDNS TTL</b>	Specify the current DDNS settings.
<b>Default TTL</b>	
<b>DDNS Refresh Time</b>	
<b>Enable mDNS</b> Off On*	Update the multicast DNS settings.
<b>WINS Server Address</b>	Specify a server address for Windows Internet Name Service (WINS).
<b>Enable BOOTP</b> Off* On	Allow the BOOTP to assign a printer IP address.
<b>Restricted Server List</b>	Specify the IP addresses that are allowed to communicate with the printer over TCP/IP.  <b>Notes:</b> <ul style="list-style-type: none"> <li>• Use a comma to separate each IP address.</li> <li>• You can add up to 50 IP addresses.</li> </ul>
<b>Note:</b> An asterisk (*) next to a value indicates the factory default setting.	

Menu item	Description
<b>Restricted Server List Options</b> Block All Ports* Block Printing Only Block Printing and HTTP Only	Specify the access option for IP addresses that are not in the list.
<b>MTU</b> 256–1500 Ethernet (1500*)	Specify a maximum transmission unit (MTU) parameter for the TCP connections.
<b>Raw Print Port</b> 1–65535 (9100*)	Specify a raw port number for printers connected on a network.
<b>Outbound Traffic Maximum Speed</b> Off* On	Set the maximum transfer rate of the printer. <b>Note:</b> When enabled, the option for this setting is 100–1000000 Kilobits/second.
<b>Enable TLSv1.0</b> Off On*	Enable the TLSv1.0 protocol.
<b>Enable TLSv1.1</b> Off On*	Enable the TLSv1.1 protocol.
<b>SSL Cipher List</b>	Specify the cipher algorithms to use for the SSL or the TLS connections.
<b>Note:</b> An asterisk (*) next to a value indicates the factory default setting.	

## SNMP

**Note:** This menu appears only in network printers or printers that are attached to print servers.

Menu item	Description
<b>SNMP Versions 1 and 2c</b> Enabled Off On* Allow SNMP Set Off On* Enable PPM MIB Off On* SNMP Community	Configure Simple Network Management Protocol (SNMP) versions 1 and 2c to install print drivers and applications.
<b>Note:</b> An asterisk (*) next to a value indicates the factory default setting.	



Menu item	Description
<b>SNMP Version 3</b> Enabled Off On* Set Read/Write Credentials User Name Password Set Read-only Credentials User Name Password Authentication Hash MD5 SHA1* Minimum Authentication Level No Authentication, No Privacy Authentication, No Privacy Authentication, Privacy* Privacy Algorithm DES AES-128*	Configure SNMP version 3 to install and update the printer security.
<b>Note:</b> An asterisk (*) next to a value indicates the factory default setting.	

## IPSec

**Note:** This menu appears only in network printers or printers that are attached to print servers.

Menu item	Description
<b>Enable IPSec</b> Off* On	Enable Internet Protocol Security (IPSec).
<b>Base Configuration</b> Default* Compatibility Secure	Set the IPSec base configuration.  <b>Note:</b> This menu item appears only when Enable IPSec is set to On.
<b>IPSec Device Certificate</b>	Specify an IPSec certificate.  <b>Note:</b> This menu item appears only when Base Configuration is set to Compatibility.
<b>Note:</b> An asterisk (*) next to a value indicates the factory default setting.	

Menu item	Description
<b>Pre-Shared Key Authenticated Connections</b> Host [x] Address Key	Configure the authenticated connections of the printer. <b>Note:</b> These menu items appear only when Enable IPsec is set to On.
<b>Certificate Authenticated Connections</b> Host [x] Address[/subnet] Address[/subnet]	
<b>Note:</b> An asterisk (*) next to a value indicates the factory default setting.	

## 802.1x

**Note:** This menu appears only in network printers or printers that are attached to print servers.

Menu item	Description
<b>Active</b> Off* On	Let the printer join networks that require authentication before allowing access. <b>Note:</b> To configure the settings of this menu item, access the Embedded Web Server.
<b>Note:</b> An asterisk (*) next to a value indicates the factory default setting.	

## LPD Configuration

**Note:** This menu appears only in network printers or printers that are attached to print servers.

Menu item	Description
<b>LPD Timeout</b> 0–65535 seconds (90*)	Set the time-out value to stop the Line Printer Daemon (LPD) server from waiting indefinitely for hung or invalid print jobs.
<b>LPD Banner Page</b> Off* On	Print a banner page for all LPD print jobs. <b>Note:</b> A banner page is the first page of a print job used as a separator of print jobs and to identify the originator of the print job request.
<b>LPD Trailer Page</b> Off* On	Print a trailer page for all LPD print jobs. <b>Note:</b> A trailer page is the last page of a print job.
<b>LPD Carriage Return Conversion</b> Off* On	Enable carriage return conversion. <b>Note:</b> Carriage return is a mechanism that commands the printer to move the position of the cursor to the first position on the same line.
<b>Note:</b> An asterisk (*) next to a value indicates the factory default setting.	

## HTTP/FTP Settings

Menu item	Description
<b>Enable HTTP Server</b> Off On*	Access the Embedded Web Server to monitor and manage the printer.
<b>Enable HTTPS</b> Off On*	Configure the Hypertext Transfer Protocol Secure (HTTPS) settings.
<b>Force HTTPS Connections</b> On Off*	Force the printer to use the HTTPS connections.
<b>Enable FTP/TFTP</b> Off On*	Send files using FTP.
<b>Local Domains</b>	Specify domain names for HTTP and FTP servers. <b>Note:</b> This menu item appears only in the Embedded Web Server.
<b>HTTP Proxy IP Address</b>	Configure the HTTP and FTP server settings. <b>Note:</b> HTTP Proxy IP Address and FTP Proxy IP Address appear only in the Embedded Web Server.
<b>FTP Proxy IP Address</b>	
<b>HTTP Default IP Port</b> 1–65535 (80*)	
<b>HTTPS Device Certificate</b>	
<b>FTP Default IP Port</b> 1–65535 (21*)	
<b>Timeout for HTTP/FTP Requests</b> 1–299 (30*)	Specify the amount of time before the server connection stops.
<b>Retries for HTTP/FTP Requests</b> 1–299 (3*)	Set the number of retries to connect to the HTTP/FTP server.
<b>Note:</b> An asterisk (*) next to a value indicates the factory default setting.	

## ThinPrint

Menu item	Description
<b>Enable ThinPrint</b> Off On*	Print using ThinPrint.
<b>Port Number</b> 4000–4999 (4000*)	Set the port number for the ThinPrint server.
<b>Note:</b> An asterisk (*) next to a value indicates the factory default setting.	

Menu item	Description
<b>Bandwidth (bits/sec)</b> 0* 100–1000000	Set the speed to transmit data in a ThinPrint environment.
<b>Packet Size (kbytes)</b> 0–64000 (0*)	Set the packet size for data transmission.
<b>Note:</b> An asterisk (*) next to a value indicates the factory default setting.	

## USB

Menu item	Description
<b>PCL SmartSwitch</b> On* Off	Set the printer to switch to PCL emulation when a print job received through a USB port requires it, regardless of the default printer language.  <b>Note:</b> If PCL SmartSwitch is off, then the printer does not examine incoming data and uses the default printer language specified in the Setup menu.
<b>PS SmartSwitch</b> On* Off	Set the printer to switch to PS emulation when a print job received through a USB port requires it, regardless of the default printer language.  <b>Note:</b> If PS SmartSwitch is off, then the printer does not examine incoming data and uses the default printer language specified in the Setup menu.
<b>Mac Binary PS</b> Auto* On Off	Set the printer to process Macintosh binary PostScript print jobs.  <b>Notes:</b> <ul style="list-style-type: none"> <li>• On processes raw binary PostScript print jobs.</li> <li>• Off filters print jobs using the standard protocol.</li> </ul>
<b>Enable USB Port</b> Enable* Disable	Enable the standard USB port.
<b>Note:</b> An asterisk (*) next to a value indicates the factory default setting.	

## Restrict external network access

Menu item	Description
<b>Restrict external network access</b> Off* On	Restrict access to network sites.
<b>External network address</b>	Specify the network addresses with restricted access.
<b>E-mail address for notification</b>	Specify an e-mail address to send a notification of logged events.
<b>Ping frequency</b> 1–300 (10*)	Specify the network query interval in seconds.
<b>Note:</b> An asterisk (*) next to a value indicates the factory default setting.	

Menu item	Description
<b>Subject</b>	Specify the subject and message of the notification e-mail.
<b>Message</b>	
<b>Note:</b> An asterisk (*) next to a value indicates the factory default setting.	

## Google Cloud Print

Menu item	Description
<b>Registration</b> Register	Register the printer to the Google Cloud Print server.
<b>Options</b> Enable Google Cloud Print Off On*	Print directly from your Google account.
<b>Options</b> Enable Local Discovery Off On*	Allow the registered user and other users on the same subnet to send jobs to the printer locally.
<b>Options</b> Enable SSL Peer Verification Off On*	Verify authenticity of the peer certificate to connect to your Google account.
<b>Options</b> Always Print As Image Off* On	Enable the Always Print As Image feature.
<b>Note:</b> An asterisk (*) next to a value indicates the factory default setting.	

## Wi-Fi Direct

**Note:** This menu appears only when a direct Wi-Fi network is the active network.

Menu item	Description
<b>SSID</b>	Specify the service set identifier (SSID) of the Wi-Fi network.
<b>Preferred Channel Number</b> Auto 1–11 (6*)	Show the PSK on the Network Setup Page.
<b>Set PSK</b>	Set the preshared key (PSK) to authenticate and validate users on a Wi-Fi connection.
<b>Note:</b> An asterisk (*) next to a value indicates the factory default setting.	

Menu item	Description
<b>Show PSK on Setup Page</b> Off On*	Show the PSK on the Network Setup Page.
<b>Group Owner IP Address</b>	Specify the IP address of the group owner.
<b>Auto-Accept Push Button Requests</b> Off* On	Accept requests to connect to the network automatically. <b>Note:</b> Accepting clients automatically is not secure.
<b>Note:</b> An asterisk (*) next to a value indicates the factory default setting.	

## USB Drive

### Flash Drive Scan

Menu item	Description
<b>Format</b> PDF (.pdf)* TIFF (.tif) JPEG (.jpg) XPS (.xps)	Specify the file format for the scanned image. <b>Note:</b> The settings may vary depending on your printer model.
<b>Global OCR Settings</b> Recognized Languages Auto Rotate Despeckle Auto Contrast Enhance	Configure the settings for optical character recognition (OCR). <b>Note:</b> This menu appears only if you have purchased and installed an OCR solution.
<b>Note:</b> An asterisk (*) next to a value indicates the factory default setting.	

Menu item	Description
<p><b>PDF Settings</b></p> <ul style="list-style-type: none"> <li>PDF Version                             <ul style="list-style-type: none"> <li>1.3</li> <li>1.4</li> <li>1.5*</li> <li>1.6</li> <li>1.7</li> </ul> </li> <li>Archival Version                             <ul style="list-style-type: none"> <li>A-1a*</li> <li>A-1b</li> </ul> </li> <li>Secure                             <ul style="list-style-type: none"> <li>Off*</li> <li>On</li> </ul> </li> <li>Archival (PDF/A)                             <ul style="list-style-type: none"> <li>Off*</li> <li>On</li> </ul> </li> </ul>	<p>Set the PDF format for the scanned image.</p>
<p><b>Content Type</b></p> <ul style="list-style-type: none"> <li>Text</li> <li>Text/Photo*</li> <li>Graphics</li> <li>Photo</li> </ul>	<p>Improve the output result based on the content of the original document.</p>
<p><b>Content Source</b></p> <ul style="list-style-type: none"> <li>Black and White Laser</li> <li>Color Laser*</li> <li>Inkjet</li> <li>Photo/Film</li> <li>Magazine</li> <li>Newspaper</li> <li>Press</li> <li>Other</li> </ul>	<p>Improve the output result based on the source of the original document.</p>
<p><b>Color</b></p> <ul style="list-style-type: none"> <li>Black and White</li> <li>Gray</li> <li>Color*</li> <li>Auto</li> </ul>	<p>Specify the color when scanning an image.</p>
<p><b>Resolution</b></p> <ul style="list-style-type: none"> <li>75 dpi</li> <li>150 dpi*</li> <li>200 dpi</li> <li>300 dpi</li> <li>400 dpi</li> <li>600 dpi</li> </ul>	<p>Set the resolution of the scanned image.</p>
<p><b>Note:</b> An asterisk (*) next to a value indicates the factory default setting.</p>	

Menu item	Description
<b>Darkness</b> 1–9 (5*)	Adjust the darkness of the scanned image.
<b>Orientation</b> Portrait* Landscape	Specify the orientation of text and graphics on the page.
<b>Original Size</b> [List of paper sizes]	Set the paper size of the original document. <b>Notes:</b> <ul style="list-style-type: none"> <li>• Letter is the U.S. factory default setting. A4 is the international factory default setting.</li> <li>• This menu item may vary depending on your printer model.</li> </ul>
<b>Sides</b> Off* Long edge Short edge	Specify the page orientation of text and graphics when scanning a two-sided document.
<b>File Name</b>	Specify the file name of the scanned image.
<b>Note:</b> An asterisk (*) next to a value indicates the factory default setting.	

### Advanced Imaging

Menu item	Description
<b>Color Balance</b>	Adjust the amount of toner used for each color.
<b>Color Dropout</b> Color Dropout None* Red Green Blue Default Red Threshold 0–255 (128*) Default Green Threshold 0–255 (128*) Default Blue Threshold 0–255 (128*)	Specify which color to drop during scanning, and adjust the dropout setting for that color.
<b>Auto Color Detect</b> Color Sensitivity 1–9 (5*) Area Sensitivity 1–9 (5*)	Set the amount of color that the printer detects from the original document. <b>Note:</b> This menu item appears only when Color is set to Auto.
<b>Note:</b> An asterisk (*) next to a value indicates the factory default setting.	



Menu item	Description
<b>JPEG Quality</b> Best for content* 5–95	Set the quality of a JPEG-format image. <b>Notes:</b> <ul style="list-style-type: none"> <li>• 5 reduces the file size, but lessens the image quality.</li> <li>• 90 provides the best image quality, but produces a large file size.</li> </ul>
<b>Contrast</b> Best for content* 0 1 2 3 4 5	Specify the contrast of the output.
<b>Background Removal</b> Background Detection Content-based* Fixed Level -4 to 4 (0*)	Adjust the amount of background visible on a scanned image. <b>Note:</b> If you want to remove the background color from the original document, then set Background Detection to Content-based. If you want to remove image noise from a photo, then set Background Detection to Fixed.
<b>Mirror Image</b> Off* On	Create a mirror image of the original document.
<b>Negative Image</b> Off* On	Create a negative image of the original document.
<b>Shadow Detail</b> -4 to 4 (0*)	Adjust the amount of shadow detail visible on a scanned image.
<b>Scan Edge to Edge</b> Off* On	Allow edge-to-edge scanning of the original document.
<b>Sharpness</b> 1–5 (3*)	Adjust the sharpness of a scanned image.
<b>Temperature</b> -4 to 4 (0*)	Specify whether to generate a cooler or warmer output.
<b>Blank Pages</b> Blank Page Removal Blank Page Sensitivity	Specify whether to include blank pages.
<b>Note:</b> An asterisk (*) next to a value indicates the factory default setting.	

## Admin Controls

Menu item	Description
<b>Text Default</b> 5–95 (75*)	Set the quality of text on a scanned image.
<b>Text/Photo Default</b> 5–95 (75*)	Set the quality of text or photo on a scanned image.
<b>Photo Default</b> 5–95 (75*)	Set the quality of a photo on a scanned image.
<b>Use Multi-Page TIFF</b> On* Off	Choose between single- and multiple-page TIFF files.
<b>TIFF Compression</b> LZW* JPEG	Set the compression for TIFF files.
<b>Scan Bit Depth</b> 1 bit 8 bit*	Enable the Text/Photo mode to have smaller file sizes by using 1-bit image. <b>Note:</b> This menu item appears only when Color is set to Gray.
<b>Custom Job Scanning</b> Off* On	Turn on scanning of custom jobs by default. <b>Note:</b> This menu item appears only when a hard disk is installed.
<b>Scan Preview</b> Off On*	Show a preview of the scan on the display. <b>Note:</b> This menu item appears only when a hard disk is installed.
<b>Note:</b> An asterisk (*) next to a value indicates the factory default setting.	

## Flash Drive Print

Menu item	Description
<b>Number of Copies</b> 1–9999 (1*)	Set the number of copies.
<b>Paper Source</b> Tray [x] (1*) Multipurpose Feeder Manual Paper Manual Envelope	Set the paper source for the print job. <b>Note:</b> The multipurpose feeder is available only in some printer models.
<b>Collate</b> (1,1,1) (2,2,2) (1,2,3) (1,2,3)*	Print multiple copies in sequence.
<b>Note:</b> An asterisk (*) next to a value indicates the factory default setting.	

Menu item	Description
<b>Sides</b> 1-Sided* 2-Sided	Specify whether to print on one side or two sides of the paper.
<b>Flip Style</b> Long Edge* Short Edge	Determine which side of the paper (long edge or short edge) is bound when performing two-sided printing. <b>Note:</b> Depending on the option selected, the printer automatically offsets each printed information of the page to bind the job correctly.
<b>Pages per Side</b> Off* 2 pages per side 3 pages per side 4 pages per side 6 pages per side 9 pages per side 12 pages per side 16 pages per side	Print multiple page images on one side of a sheet of paper.
<b>Pages per Side Ordering</b> Horizontal* Reverse Horizontal Reverse Vertical Vertical	Specify the positioning of multiple page images when using Pages per Side. <b>Note:</b> The positioning depends on the number of page images and their page orientation.
<b>Pages per Side Orientation</b> Auto* Landscape Portrait	Specify the orientation of a multiple-page document when using Pages per Side.
<b>Pages per Side Border</b> None* Solid	Print a border around each page image when using Pages per Side.
<b>Separator Sheets</b> Off* Between Copies Between Jobs Between Pages	Specify whether to insert blank separator sheets when printing.
<b>Separator Sheet Source</b> Tray [x] (1*) Multipurpose Feeder	Specify the paper source for the separator sheet. <b>Note:</b> The multipurpose feeder is available only in some printer models.
<b>Blank Pages</b> Do Not Print* Print	Specify whether to print blank pages in a print job.
<b>Note:</b> An asterisk (*) next to a value indicates the factory default setting.	

# Security

## Login Methods

### Manage Permissions

Menu item	Description
<p><b>Function Access</b></p> <ul style="list-style-type: none"> <li>Access Address Book in Apps</li> <li>Modify Address Book</li> <li>Manage Shortcuts</li> <li>Create Profiles</li> <li>Manage Bookmarks</li> <li>Flash Drive Print</li> <li>Flash Drive Scan</li> <li>Copy Function</li> <li>Color Dropout</li> <li>E-mail Function</li> <li>Fax Function</li> <li>FTP Function</li> <li>Release Held Faxes</li> <li>Held Jobs Access</li> <li>User Profiles</li> <li>Cancel Jobs at the Device</li> <li>Change Language</li> <li>Internet Printing Protocol (IPP)</li> <li>Initiate Scans Remotely</li> <li>B/W Print</li> <li>Network Folder - Scan</li> </ul>	<p>Control access to the printer functions.</p>
<p><b>Administrative Menus</b></p> <ul style="list-style-type: none"> <li>Security Menu</li> <li>Network/Ports Menu</li> <li>Paper Menu</li> <li>Reports Menu</li> <li>Function Configuration Menus</li> <li>Supplies Menu</li> <li>Option Card Menu</li> <li>SE Menu</li> <li>Device Menu</li> </ul>	<p>Control access to the printer menu settings.</p>

Menu item	Description
<p><b>Device Management</b></p> <ul style="list-style-type: none"> <li>Remote Management</li> <li>Firmware Updates</li> <li>Apps Configuration</li> <li>Operator Panel Lock</li> <li>Import/Export All Settings</li> <li>Out of Service Erase</li> <li>Embedded Web Server Access</li> </ul>	<p>Control access to the printer management options.</p>
<p><b>Apps</b></p> <ul style="list-style-type: none"> <li>New Apps</li> <li>Scan Center</li> <li>Scan Center Custom 1</li> <li>Scan Center Custom 2</li> <li>Scan Center Custom 3</li> <li>Scan Center Custom 4</li> <li>Scan Center Custom 5</li> <li>Scan Center Custom 6</li> <li>Scan Center Custom 7</li> <li>Scan Center Custom 8</li> <li>Scan Center Custom 9</li> <li>Scan Center Custom 10</li> </ul>	<p>Control access to printer applications.</p>

**Local Accounts**

Menu item	Description
<p><b>Manage Groups/Permissions</b></p> <ul style="list-style-type: none"> <li>Add Group                             <ul style="list-style-type: none"> <li>Import Access Controls</li> <li>Function Access</li> <li>Administrative Menus</li> <li>Device Management</li> <li>Apps</li> </ul> </li> <li>All Users                             <ul style="list-style-type: none"> <li>Import Access Controls</li> <li>Function Access</li> <li>Administrative Menus</li> <li>Device Management</li> <li>Apps</li> </ul> </li> <li>Admin</li> </ul>	<p>Control group or user access to the printer functions, applications, and security settings.</p>

Menu item	Description
<b>Add User</b> User Name/Password User Name Password PIN	Create local accounts to manage access to the printer functions.
<b>User Name/Password Accounts</b> Add User	
<b>User Name Accounts</b> Add User	
<b>Password Accounts</b> Add User	
<b>PIN Accounts</b> Add User	

### Schedule USB Devices

Menu item	Description
<b>Schedules</b> Add New Schedule	Schedule access to the USB ports.

### Security Audit Log

Menu item	Description
<b>Enable Audit</b> Off* On	Record the events in the secure audit log and remote syslog.
<b>Enable Remote Syslog</b> Off* On	Send audit logs to a remote server.
<b>Remote Syslog Server</b>	Specify the remote syslog server.
<b>Remote Syslog Port</b> 1–65535 (514*)	Specify the remote syslog port.
<b>Remote Syslog Method</b> Normal UDP* Stunnel	Specify a syslog method to transmit logged events to a remote server.

**Note:** An asterisk (\*) next to a value indicates the factory default setting.

Menu item	Description
<p><b>Remote Syslog Facility</b></p> <ul style="list-style-type: none"> <li>0 - Kernel Messages</li> <li>1 - User-Level Messages</li> <li>2 - Mail System</li> <li>3 - System Daemons</li> <li>4 - Security/Authorization Messages*</li> <li>5 - Messages Generated Internally by Syslogs</li> <li>6 - Line Printer Subsystem</li> <li>7 - Network News Subsystem</li> <li>8 - UUCP Subsystem</li> <li>9 - Clock Daemon</li> <li>10 - Security/Authorization Messages</li> <li>11 - FTP Daemon</li> <li>12 - NTP Subsystem</li> <li>13 - Log Audit</li> <li>14 - Log Alert</li> <li>15 - Clock Daemon</li> <li>16 - Local Use 0 (local0)</li> <li>17 - Local Use 1 (local1)</li> <li>18 - Local Use 2 (local2)</li> <li>19 - Local Use 3 (local3)</li> <li>20 - Local Use 4 (local4)</li> <li>21 - Local Use 5 (local5)</li> <li>22 - Local Use 6 (local6)</li> <li>23 - Local Use 7 (local7)</li> </ul>	<p>Specify a facility code that the printer uses when sending log events to a remote server.</p>
<p><b>Severity of Events to Log</b></p> <ul style="list-style-type: none"> <li>0 - Emergency</li> <li>1 - Alert</li> <li>2 - Critical</li> <li>3 - Error</li> <li>4 - Warning*</li> <li>5 - Notice</li> <li>6 - Informational</li> <li>7 - Debug</li> </ul>	<p>Specify the priority level cutoff for logging messages and events.</p>
<p><b>Remote Syslog Non-Logged Events</b></p> <ul style="list-style-type: none"> <li>Off*</li> <li>On</li> </ul>	<p>Send all events, regardless of severity level, to the remote server.</p>
<p><b>Admin's E-mail Address</b></p>	<p>Send e-mail notification of logged events to the administrator.</p>
<p><b>Note:</b> An asterisk (*) next to a value indicates the factory default setting.</p>	

Menu item	Description
<b>E-mail Log Cleared Alert</b> Off* On	Send e-mail notification to the administrator when a log entry is deleted.
<b>E-mail Log Wrapped Alert</b> Off* On	Send e-mail notification to the administrator when the log becomes full and begins to overwrite the oldest entries.
<b>Log Full Behavior</b> Wrap Over Older Entries* E-mail Log Then Delete All Entries	Resolve log storage issues when the log fills its allotted memory.
<b>E-mail % Full Alert</b> Off* On	Send e-mail notification to the administrator when the log fills its allotted memory.
<b>% Full Alert Level</b> 1–99 (90*)	
<b>E-mail Log Exported Alert</b> Off* On	Send e-mail notification to the administrator when a log is exported.
<b>E-mail Log Settings Changed Alert</b> Off* On	Send e-mail notification to the administrator when Enable Audit is set.
<b>Log Line Endings</b> LF (\n)* CR (\r) CRLF (\r\n)	Specify how the log file terminates the end of each line.
<b>Digitally Sign Exports</b> Off* On	Add a digital signature to each exported log file.
<b>Clear Log</b>	Delete all audit logs.
<b>Export Log</b> Syslog (RFC 5424) Syslog (RFC 3164) CSV	Export a security log to a flash drive.
<b>Note:</b> An asterisk (*) next to a value indicates the factory default setting.	



## Login Restrictions

Menu item	Description
<b>Login failures</b> 1–10 (3*)	Specify the number of failed login attempts before the user gets locked out.
<b>Failure time frame</b> 1–60 minutes (5*)	Specify the time frame between failed login attempts before the user gets locked out.
<b>Lockout time</b> 1–60 minutes (5*)	Specify the lockout duration.
<b>Web Login Timeout</b> 1–120 minutes (10*)	Specify the delay for a remote login before the user is logged off automatically.
<b>Note:</b> An asterisk (*) next to a value indicates the factory default setting.	

## Confidential Print Setup

Menu item	Description
<b>Max Invalid PIN</b> 2–10	Set the number of times an invalid PIN can be entered.  <b>Notes:</b> <ul style="list-style-type: none"> <li>• A value of zero turns off this setting.</li> <li>• When the limit is reached, the print jobs for that user name and PIN are deleted.</li> <li>• This menu item appears only when a hard disk is installed.</li> </ul>
<b>Confidential Job Expiration</b> Off* 1 Hour 4 Hours 24 Hours 1 Week	Set the expiration time for confidential print jobs.  <b>Notes:</b> <ul style="list-style-type: none"> <li>• If this menu item is changed while confidential print jobs reside in the printer memory or hard disk, then the expiration time for those print jobs does not change to the new default value.</li> <li>• If the printer is turned off, then all confidential jobs held in the printer memory are deleted.</li> </ul>
<b>Repeat Job Expiration</b> Off* 1 Hour 4 Hours 24 Hours 1 Week	Set the expiration time for a print job that you want to repeat.
<b>Verify Job Expiration</b> Off* 1 Hour 4 Hours 24 Hours 1 Week	Set the expiration time that the printer prints a copy for the user to examine its quality, before printing the remaining copies.
<b>Note:</b> An asterisk (*) next to a value indicates the factory default setting.	

Menu item	Description
<b>Reserve Job Expiration</b> Off* 1 Hour 4 Hours 24 Hours 1 Week	Set the expiration time that the printer stores print jobs for printing later.
<b>Require All Jobs to be Held</b> Off* On	Set the printer to hold all print jobs.
<b>Keep duplicate documents</b> Off* On	Set the printer to print other documents with the same file name without overwriting any of the print jobs.
<b>Note:</b> An asterisk (*) next to a value indicates the factory default setting.	

## Disk Encryption

**Note:** This menu appears only when a printer hard disk is installed.

Menu item	Description
<b>Status</b> Enabled Disabled	Determine whether Disk Encryption is enabled.
<b>Start encryption</b>	Prevent the loss of sensitive data in case the printer or its hard disk is stolen. <b>Note:</b> Enabling disk encryption erases all contents in the hard disk. If necessary, back up important data from the printer before starting the encryption.

## Erase Temporary Data Files

Menu item	Description
<b>Stored in onboard memory</b> Off* On	Delete all files stored on the printer memory.
<b>Stored on hard disk</b> 1 Pass Erase* 3 Pass Erase 7 Pass Erase	Delete all files stored on the printer hard disk.
<b>Note:</b> An asterisk (*) next to a value indicates the factory default setting.	

## Solutions LDAP Settings

Use	To
<b>Follow LDAP Referrals</b> Off* On	Search the different servers in the domain for the logged-in user account.
<b>LDAP Certificate Verification</b> No* Yes	Enable verification of LDAP certificates.

## Mobile Services Management

Use	To
<b>AirPrint</b> Print Scan Fax	Enable functions in the AirPrint software feature.

## Miscellaneous

Menu item	Description
<b>Protected Features</b> Show* Hide	Show all the features that Function Access Control (FAC) protects regardless of the security permission that the user has. <b>Note:</b> FAC manages access to specific menus and functions or disables them entirely.
<b>Print Permission</b> Off* On	Let the user log in before printing.
<b>Default Print Permission Login</b>	Set the default login for Print Permission.
<b>Security Reset Jumper</b> Enable "Guest" access* No Effect	Specify the effect of using the security reset jumper. <b>Notes:</b> <ul style="list-style-type: none"> <li>• The jumper is located beside a lock icon on the controller board.</li> <li>• Enable "Guest" access provides full access control to users who are not logged in.</li> <li>• No Effect means that the reset has no effect on the printer security configuration.</li> </ul>
<b>Minimum Password Length</b> 0–32 (0*)	Specify the minimum characters that are allowed for a password.
<b>Note:</b> An asterisk (*) next to a value indicates the factory default setting.	

## Reports

### Menu Settings Page

Menu item	Description
<b>Menu Settings Page</b>	Print a report that contains the printer menus.

### Device

Menu item	Description
<b>Device Information</b>	Print a report that contains information about the printer.
<b>Device Statistics</b>	Print a report about printer usage and supply status.
<b>Profile List</b>	Print a list of profiles that are stored in the printer.
<b>Asset Report</b>	Print a report that contains the printer serial number and model name.

### Print

Menu item	Description
<b>Print Fonts</b> PCL Fonts PS Fonts	Print samples and information about the fonts that are available in each printer language.
<b>Print Demo</b>	Print sample pages.
<b>Print Directory</b>	Print the resources that are stored in the flash drive or hard disk. <b>Note:</b> This menu item appears only when a flash drive or hard disk is installed.

### Shortcuts

Menu item	Description
<b>All Shortcuts</b>	Print a report that lists the shortcuts that are stored in the printer.
<b>Fax Shortcuts</b>	
<b>Copy Shortcuts</b>	
<b>E-mail Shortcuts</b>	
<b>FTP Shortcuts</b>	
<b>Network Folder Shortcuts</b>	

## Fax

Menu item	Description
<b>Fax Job Log</b>	Print a report about the last 200 completed fax jobs. <b>Note:</b> This menu item appears only when Enable Job Log is set to On.
<b>Fax Call Log</b>	Print a report about the last 100 attempted, received, and blocked calls. <b>Note:</b> This menu item appears only when Enable Job Log is set to On.

## Network

Menu item	Description
<b>Network Setup Page</b>	Print a page that shows the configured network and wireless settings on the printer. <b>Note:</b> This menu item appears only in network printers or printers connected to print servers.

## Help

Menu item	Description
Print All Guides	Prints all the guides
Connection Guide	Provides information about connecting the printer locally (USB) or to a network
Copy Guide	Provides information about making copies and configuring the settings
E-mail Guide	Provides information about sending e-mails and configuring the settings
Fax Guide	Provides information about sending faxes and configuring the settings
FTP Guide	Provides information about scanning documents and configuring the settings
Information Guide	Provides more information sources about the printer
Media Guide	Provides information about loading paper and specialty media
Mono Quality Guide	Provides information about mono print quality settings
Moving Guide	Provides information about moving, locating, or shipping the printer
Print Quality Guide	Provides information about solving print quality issues
Supplies Guide	Provides information about ordering supplies

## Troubleshooting

### Troubleshooting

Menu item	Description
<b>Print Quality Test Pages</b>	Print sample pages to identify and correct print quality defects.

Menu item	Description
<b>Cleaning the Scanner</b>	Print instructions on how to clean the scanner.

## Securing the printer

### Locating the security slot

The printer is equipped with a security lock feature. Attach a security lock compatible with most laptop computers in the location shown to secure the printer in place.

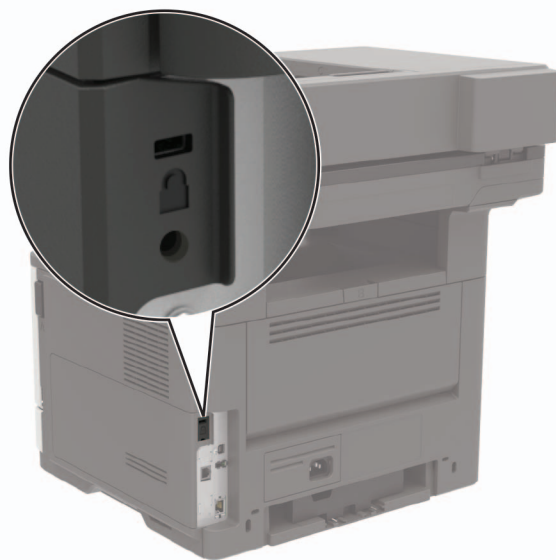

### Erasing printer memory

To erase volatile memory or buffered data in your printer, turn off the printer.

To erase non-volatile memory or individual settings, device and network settings, security settings, and embedded solutions, do the following:

- 1 From the home screen, touch **Settings** > **Device** > **Maintenance** > **Out of Service Erase**.
- 2 Select the **Sanitize all information on nonvolatile memory** check box, and then touch **ERASE**.
- 3 Follow the instructions on the display.

### Erasing printer hard disk memory

- 1 From the home screen, touch **Settings** > **Device** > **Maintenance** > **Out of Service Erase**.
- 2 Select the **Sanitize all information on hard disk** check box, and then touch **ERASE**.
- 3 Follow the instructions on the display.

**Note:** This process can take from several minutes to more than an hour, making the printer unavailable for other tasks.

## Encrypting the printer hard disk

This process erases all contents in the hard disk. If necessary, back up important data from the printer before starting the encryption.

- 1 From the home screen, touch **Settings** > **Security** > **Disk Encryption** > **Start encryption**.
- 2 Follow the instructions on the display.

### Notes:

- To avoid loss of data, do not turn off the printer during the encryption process.
- This process can take from several minutes to more than an hour, making the printer unavailable for other tasks.
- After encryption, the printer automatically restarts.

## Restoring factory default settings

From the home screen, touch **Settings** > **Device** > **Restore Factory Defaults** > **Restore Settings** > **Restore all settings** > **RESTORE** > **Start**.

For more information, see [“Erasing printer memory” on page 119](#).

## Statement of Volatility

Type of memory	Description
Volatile memory	The printer uses standard random access memory (RAM) to buffer temporarily user data during simple print and copy jobs.
Non-volatile memory	The printer may use two forms of non-volatile memory: EEPROM and NAND (flash memory). Both types are used to store the operating system, printer settings, network information, scanner and bookmark settings, and embedded solutions.
Hard disk memory	Some printers may have a hard disk drive installed. The printer hard disk is designed for printer-specific functionality. The hard disk lets the printer retain buffered user data from complex print jobs, form data, and font data.

Erase the content of any installed printer memory in the following circumstances:

- The printer is decommissioned.
- The printer hard disk is replaced.
- The printer is moved to a different department or location.
- The printer is serviced by someone from outside your organization.
- The printer is removed from your premises for service.
- The printer is sold to another organization.



**Disposing of a printer hard disk**

- **Degaussing**—Flushes the hard disk with a magnetic field that erases stored data
- **Crushing**—Physically compresses the hard disk to break component parts and render them unreadable
- **Milling**—Physically shreds the hard disk into small metal bits

**Note:** To guarantee that all data are completely erased, destroy physically each hard disk where data is stored.

# Maintaining the printer

**Warning—Potential Damage:** Failure to maintain optimum printer performance, or to replace parts and supplies, may cause damage to your printer.

## Adjusting the speaker volume

### Adjusting the default internal speaker volume

The speaker volume will reset to default value after the session is logged out, when the printer wakes from Sleep or Hibernate mode, or after a power-on reset.

- 1 From the control panel, navigate to:  
**Settings > Device > Preferences > Audio Feedback**
- 2 Select the volume.

**Note:** If Quiet Mode is enabled, then audible alerts are turned off.

### Configuring the fax speaker settings

- 1 From the home screen, touch **Settings > Fax > Fax Setup > Speaker Settings**.
- 2 Do the following:
  - Set the Speaker Mode to **Always On**.
  - Set the Speaker Volume to **High**.
  - Activate the Ringer Volume.

## Networking

**Note:** For information on installing the wireless network adapter, see the setup sheet that came with the adapter.

### Connecting the printer to a Wi-Fi network

Make sure that Active Adapter is set to Auto. From the home screen, touch **Settings > Network/Ports > Network Overview > Active Adapter**.

- 1 From the home screen, touch **Settings > Network/Ports > Wireless > Setup On Printer Panel > Choose Network**.
- 2 Select a Wi-Fi network, and then type the network password.

**Note:** For Wi-Fi-network-ready printer models, a prompt for Wi-Fi network setup appears during initial setup.

## Connecting the printer to a wireless network using Wi-Fi Protected Setup (WPS)

Before you begin, make sure that:

- The access point (wireless router) is WPS-certified or WPS-compatible. For more information, see the documentation that came with your access point.
- A wireless network adapter is installed in your printer. For more information, see the instructions that came with the adapter.
- Active Adapter is set to Auto. From the home screen, touch **Settings** > **Network/Ports** > **Network Overview** > **Active Adapter**.

### Using the Push Button method

- 1 From the home screen, touch **Settings** > **Network/Ports** > **Wireless** > **Wi-Fi Protected Setup** > **Start Push Button Method**.
- 2 Follow the instructions on the display.

### Using the personal identification number (PIN) method

- 1 From the home screen, touch **Settings** > **Network/Ports** > **Wireless** > **Wi-Fi Protected Setup** > **Start PIN Method**.
- 2 Copy the eight-digit WPS PIN.
- 3 Open a web browser, and then type the IP address of your access point in the address field.

#### Notes:

- To know the IP address, see the documentation that came with your access point.
- If you are using a proxy server, then temporarily disable it to load the web page correctly.

- 4 Access the WPS settings. For more information, see the documentation that came with your access point.
- 5 Enter the eight-digit PIN, and then save the changes.

## Connecting a mobile device to the printer

Before connecting your mobile device, make sure to do the following:

- Enable Wi-Fi Direct in the printer. From the control panel, navigate to: **Settings** > **Network/Ports** > **Wireless** > **Enable Wi-Fi Direct**.
- Show the preshared key (PSK) on the Network Setup Page. From the control panel, navigate to: **Settings** > **Network/Ports** > **Wi-Fi Direct** > **Show PSK on Setup Page**.
- Print the Network Setup Page. From the control panel, navigate to: **Settings** > **Reports** > **Network** > **Network Setup Page**.

### Connecting using Wi-Fi Direct

- 1 From the mobile device, go to the settings menu.
- 2 Enable Wi-Fi, and then tap **Wi-Fi Direct**.
- 3 Select the printer SSID.
- 4 Confirm the connection on the printer control panel.

## Connecting using Wi-Fi

1 From the mobile device, go to the settings menu.

2 Tap **Wi-Fi**, and then select the printer SSID.

**Note:** The string **DIRECT-xy** (where **x** and **y** are two random characters) is added before the SSID.

3 Enter the PSK.

**Note:** The PSK is the password.

### Notes:

- You can change the SSID on the control panel. Navigate to: **Settings > Network/Ports > Wi-Fi Direct > SSID**.
- You can also change the PSK on the control panel. Navigate to: **Settings > Network/Ports > Wi-Fi Direct > Set PSK**.

## Deactivating the Wi-Fi network

1 From the printer control panel, navigate to:

**Settings > Network/Ports > Network Overview > Active Adapter > Standard Network**

For non-touch-screen printer models, press  to navigate through the settings.

2 Follow the instructions on the display.

## Cleaning printer parts

### Cleaning the printer

 **CAUTION—SHOCK HAZARD:** To avoid the risk of electrical shock when cleaning the exterior of the printer, unplug the power cord from the electrical outlet and disconnect all cables from the printer before proceeding.

### Notes:

- Perform this task after every few months.
- Damage to the printer caused by improper handling is not covered by the printer warranty.

1 Turn off the printer, and then unplug the power cord from the electrical outlet.

2 Remove paper from the standard bin and multipurpose feeder.

3 Remove any dust, lint, and pieces of paper around the printer using a soft brush or vacuum.

4 Wipe the outside of the printer with a damp, soft, lint-free cloth.

### Notes:

- Do not use household cleaners or detergents, as they may damage the finish of the printer.

- Make sure that all areas of the printer are dry after cleaning.

**5** Connect the power cord to the electrical outlet, and then turn on the printer.

**⚠ CAUTION—POTENTIAL INJURY:** To avoid the risk of fire or electrical shock, connect the power cord to an appropriately rated and properly grounded electrical outlet that is near the product and easily accessible.

## Cleaning the scanner

**1** Open the scanner cover.



**2** Using a damp, soft, lint-free cloth, wipe the following areas:

- ADF glass



- ADF glass pad



- Scanner glass



- Scanner glass pad



**3** Close the scanner cover.

**4** Open the ADF cover.

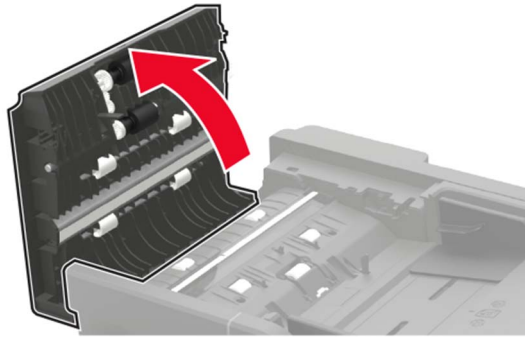

**5** Using a damp, soft, lint-free cloth, wipe the following areas:

- ADF glass pad in the ADF cover

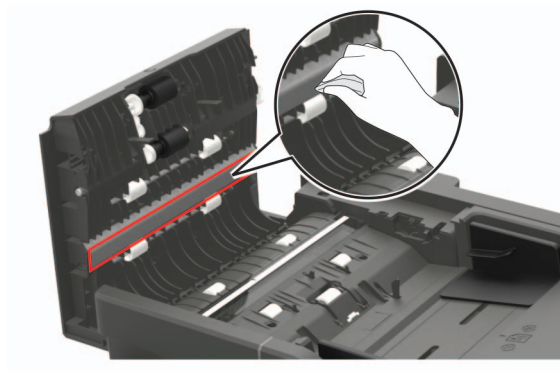

- ADF glass in the ADF cover

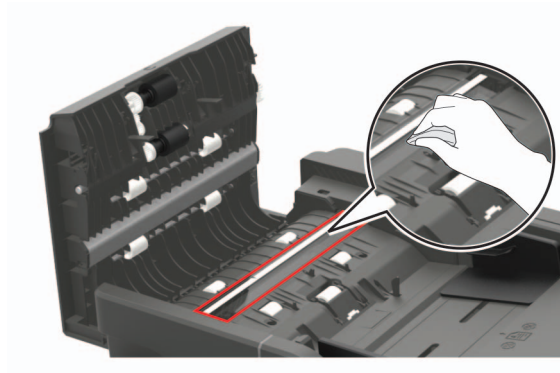

**6** Close the ADF cover.

## Ordering parts and supplies

**Note:** All life estimates for printer supplies assume printing on letter- or A4-size plain paper.

### Checking the status of parts and supplies

- 1 From the home screen, touch **Status/Supplies**.
- 2 Select the parts or supplies that you want to check.

**Note:** You can also access this setting by touching the top section of the home screen.

### Ordering a toner cartridge

**Notes:**

- The estimated cartridge yield is based on the ISO/IEC 19752 standard.
- Extremely low print coverage for extended periods of time may negatively affect actual yield.

To order a toner cartridge, contact the place where you purchased the printer.

### Ordering an imaging unit

To order an imaging unit, contact the place where you purchased the printer.

### Configuring supply notifications

- 1 Open a web browser, and then type the printer IP address in the address field.

**Notes:**

- View the printer IP address on the printer home screen. The IP address appears as four sets of numbers separated by periods, such as 123.123.123.123.
- If you are using a proxy server, then temporarily disable it to load the web page correctly.

- 2 Click **Settings > Device > Notifications**.
- 3 From the Supplies menu, click **Custom Supply Notifications**.
- 4 Select a notification for each supply item.
- 5 Apply the changes.



## Replacing parts and supplies

### Replacing the toner cartridge

- 1 Open door A.

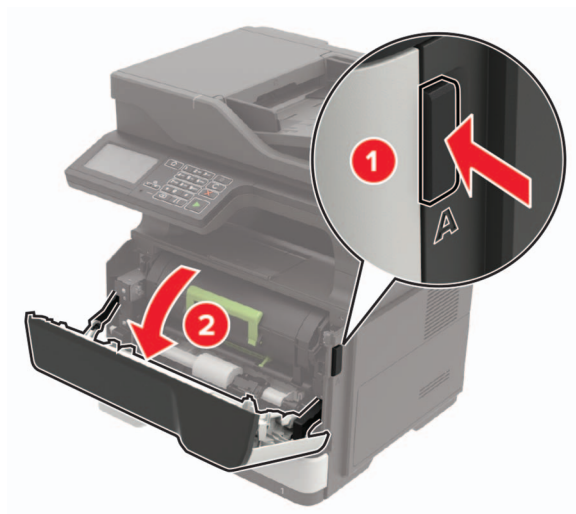

- 2 Remove the used toner cartridge.

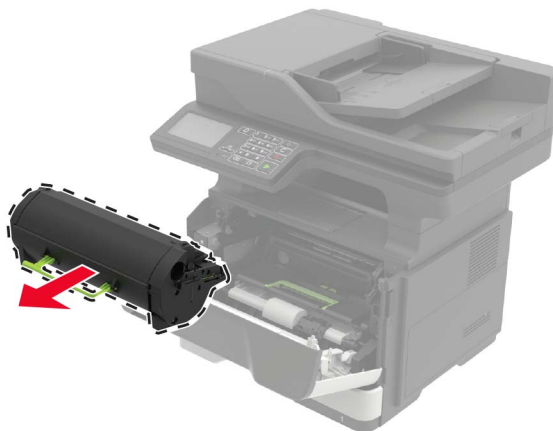

- 3** Unpack the new toner cartridge, and then shake it three times to redistribute the toner.

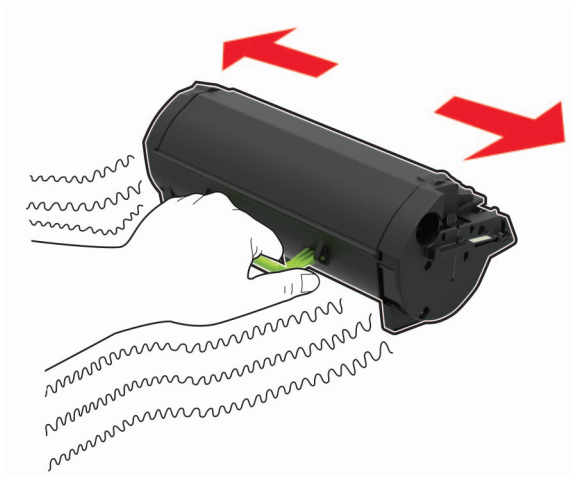

- 4** Insert the new toner cartridge.

**Note:** Use the arrows inside the printer as guides.

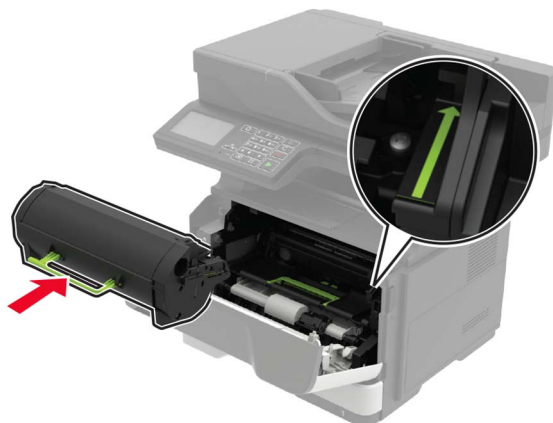

- 5** Close door A.

## Replacing the imaging unit

1 Open door A.

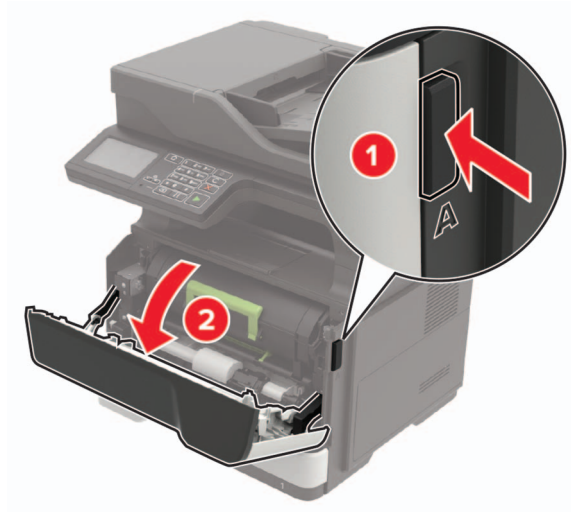

2 Remove the toner cartridge.

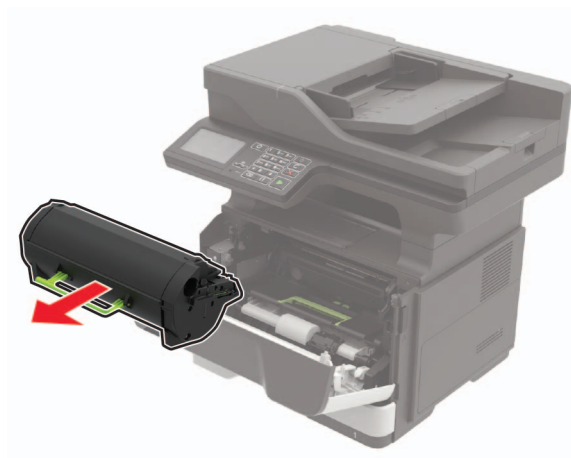

3 Remove the used imaging unit.

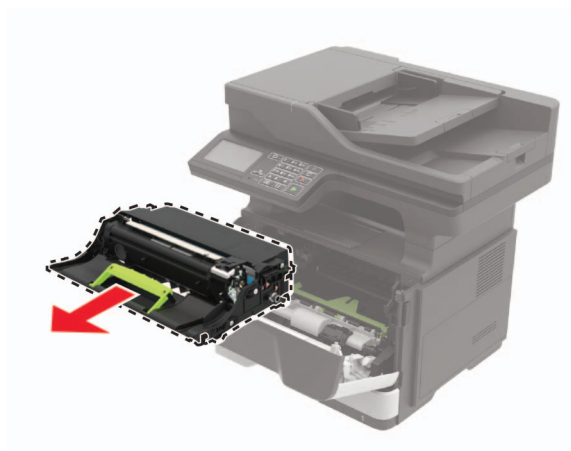

**4** Unpack the new imaging unit, and then shake it three times to redistribute the toner.

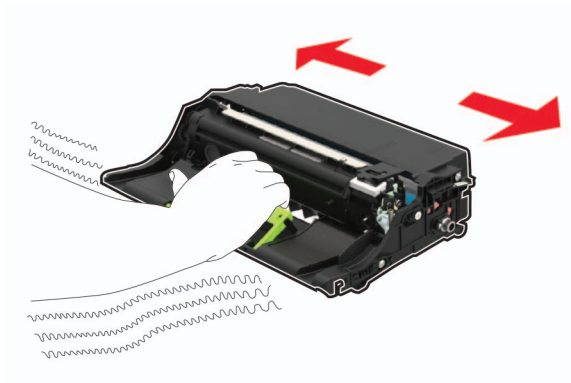

**Warning—Potential Damage:** Do not expose the imaging unit to direct light for more than 10 minutes. Extended exposure to light may cause print quality problems.

**Warning—Potential Damage:** Do not touch the photoconductor drum. Doing so may affect the quality of future print jobs.



**5** Insert the new imaging unit.

**Note:** Use the arrows inside the printer as guides.



**6** Insert the toner cartridge.

**Note:** Use the arrows inside the printer as guides.

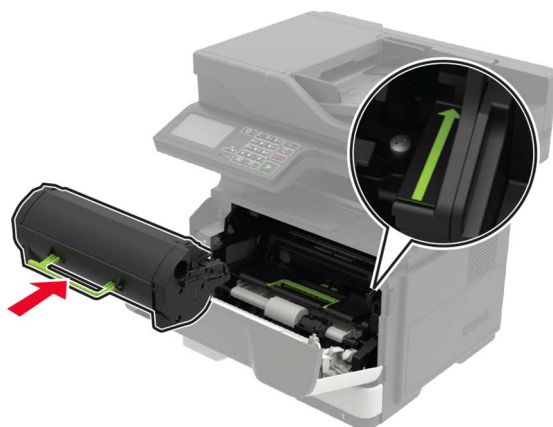

**7** Close door A.

## Replacing the pick tires

- 1** Turn off the printer.
- 2** Unplug the power cord from the electrical outlet, and then from the printer.
- 3** Remove the tray.



4 Remove the used pick tires one after the other.

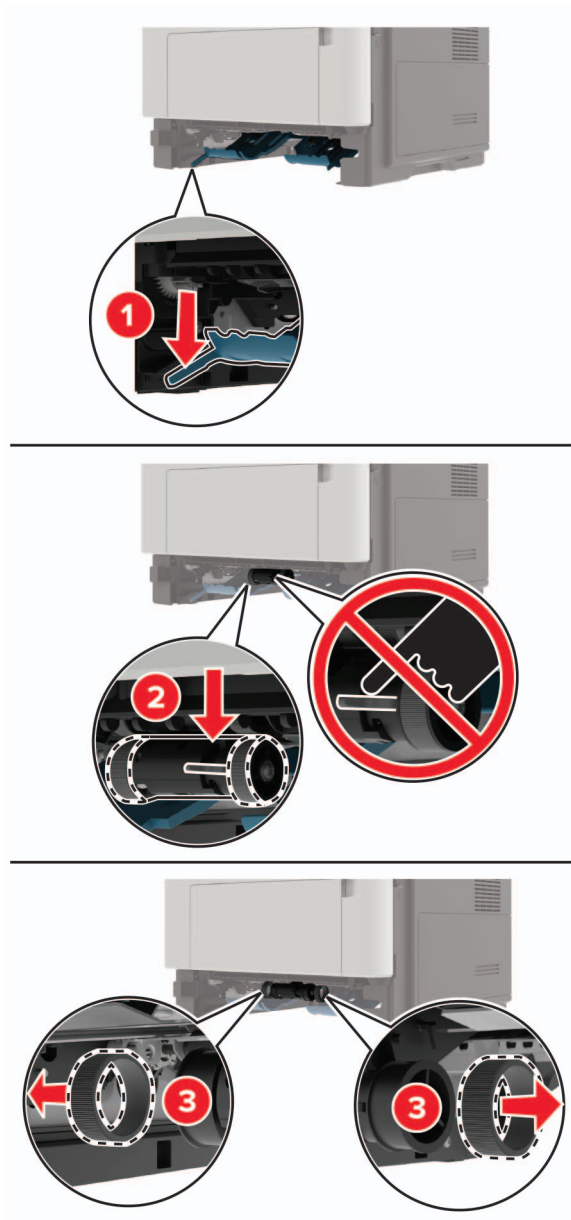

5 Unpack the new pick tires.

- 6 Insert the new pick tires.

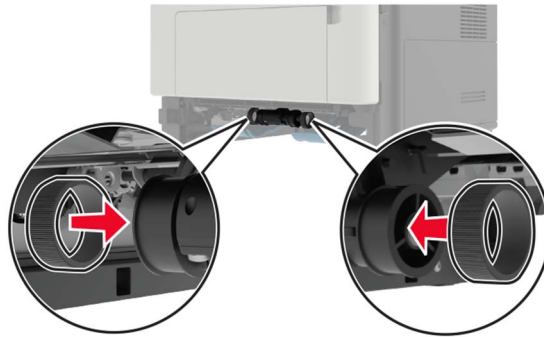

- 7 Insert the tray.
- 8 Connect the power cord to the printer, and then to the electrical outlet.

**⚠ CAUTION—POTENTIAL INJURY:** To avoid the risk of fire or electrical shock, connect the power cord to an appropriately rated and properly grounded electrical outlet that is near the product and easily accessible.

- 9 Turn on the printer.

## Replacing the pick roller assembly

- 1 Turn off the printer.
- 2 Unplug the power cord from the electrical outlet, and then from the printer.
- 3 Remove the optional tray.

**⚠ CAUTION—POTENTIAL INJURY:** If the printer weight is greater than 20 kg (44 lb), then it may require two or more people to lift it safely.

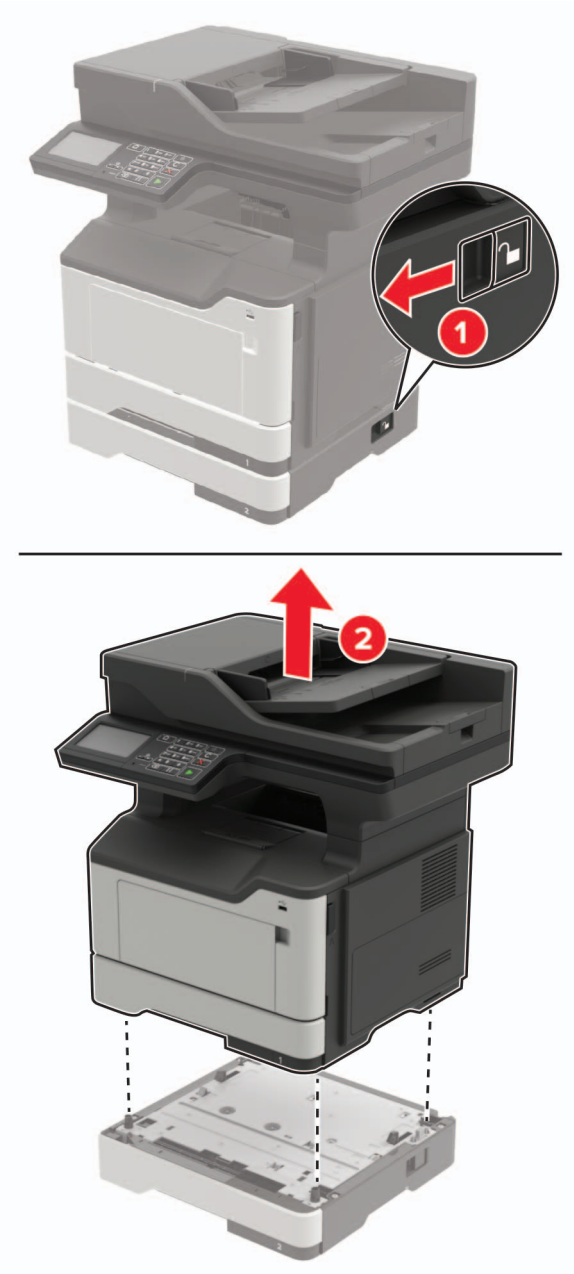



**4** Remove the tray insert, and then flip the tray base.

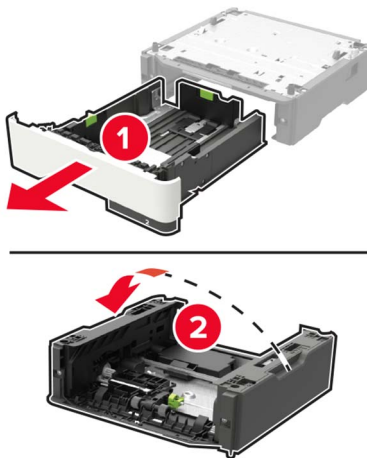

**5** Remove the used pick roller assembly.

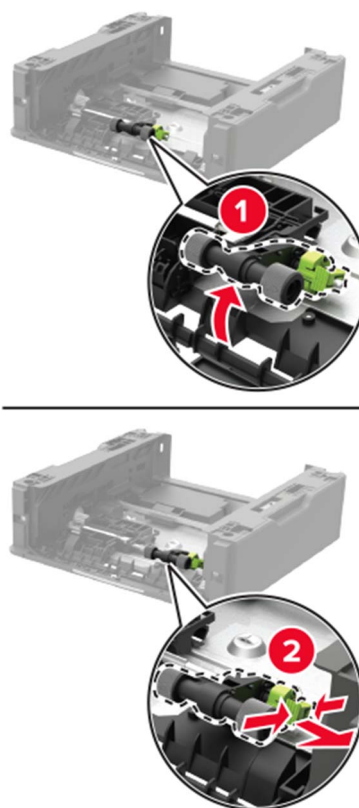

**6** Unpack the new pick roller assembly.

**7** Insert the new pick roller assembly.

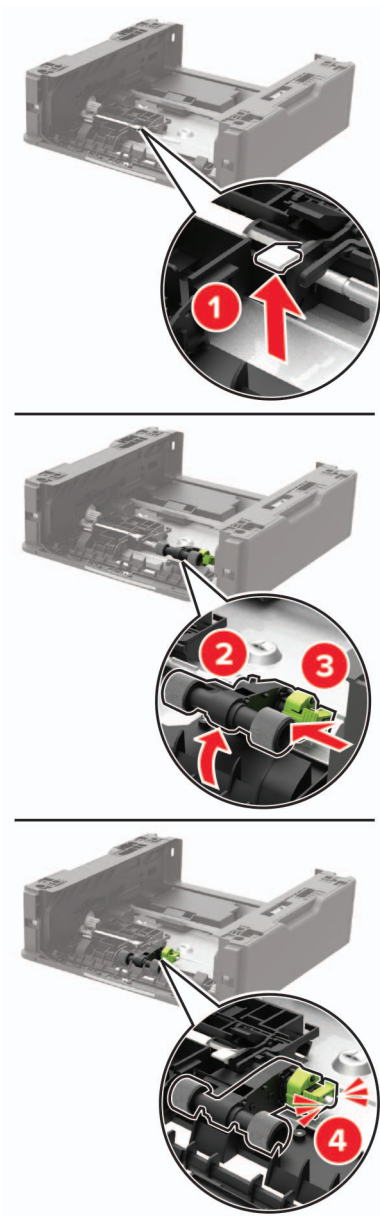

**8** Flip the tray base, and then insert the tray insert.

- 9 Align the printer with the optional tray, and then lower the printer until it *clicks* into place.



- 10 Connect the power cord to the printer, and then to the electrical outlet.

**⚠ CAUTION—POTENTIAL INJURY:** To avoid the risk of fire or electrical shock, connect the power cord to an appropriately rated and properly grounded electrical outlet that is near the product and easily accessible.

- 11 Turn on the printer.

## Moving the printer

### Moving the printer to another location

**⚠ CAUTION—POTENTIAL INJURY:** If the printer weight is greater than 20 kg (44 lb), then it requires two or more trained personnel to lift it safely.

**⚠ CAUTION—POTENTIAL INJURY:** To avoid the risk of fire or electrical shock, use only the power cord provided with this product or the manufacturer's authorized replacement.

**⚠ CAUTION—POTENTIAL INJURY:** When moving the printer, follow these guidelines to avoid personal injury or printer damage:

- Make sure that all doors and trays are closed.
- Turn off the printer, and then unplug the power cord from the electrical outlet.
- Disconnect all cords and cables from the printer.
- If the printer has separate floor-standing optional trays or output options attached to it, then disconnect them before moving the printer.
- If the printer has a caster base, then carefully roll it to the new location. Use caution when passing over thresholds and breaks in flooring.
- If the printer does not have a caster base but is configured with optional trays or output options, then remove the output options and lift the printer off the trays. Do not try to lift the printer and any options at the same time.
- Always use the handholds on the printer to lift it.

- Any cart used to move the printer must have a surface able to support the full footprint of the printer.
- Any cart used to move the hardware options must have a surface able to support the dimensions of the options.
- Keep the printer in an upright position.
- Avoid severe jarring movements.
- Make sure that your fingers are not under the printer when you set it down.
- Make sure that there is adequate clearance around the printer.

**Note:** Damage to the printer caused by improper moving is not covered by the printer warranty.

## Shipping the printer

When shipping the printer, use the original packaging or contact the place where you purchased the printer.

## Saving energy and paper

### Configuring the power save mode settings

#### Sleep mode

- 1 From the control panel, navigate to:

**Settings > Device > Power Management > Timeouts > Sleep Mode**

For non-touch-screen printer models, press  to navigate through the settings.

- 2 Specify the amount of time that the printer stays idle before it enters Sleep Mode.

#### Hibernate mode

- 1 From the control panel, navigate to:

**Settings > Device > Power Management > Timeouts > Hibernate Timeout**

For non-touch-screen printer models, press  to navigate through the settings.

- 2 Select the amount of time that the printer stays idle before it enters Hibernate mode.

#### Notes:

- For Hibernate Timeout to work, set Hibernate Timeout on Connection to Hibernate.
- The Embedded Web Server is disabled when the printer is in Hibernate mode.

### Adjusting the brightness of the printer display

- 1 From the home screen, touch **Settings > Device > Preferences > Screen Brightness**.
- 2 Adjust the setting.

## Conserving supplies

- Print on both sides of the paper.

**Note:** Two-sided printing is the default setting in the print driver.

- Print multiple pages on a single sheet of paper.
- Use the preview feature to see how the document looks like before printing it.
- Print one copy of the document to check its content and format for accuracy.

# Clearing jams

## Avoiding jams

### Load paper properly

- Make sure that the paper lies flat in the tray.

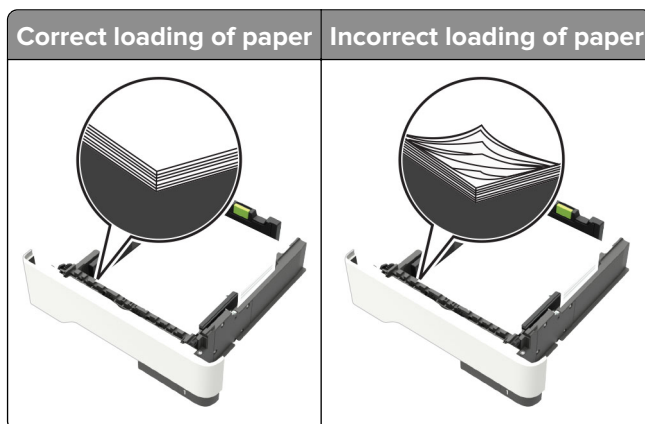

- Do not load or remove a tray while the printer is printing.
- Do not load too much paper. Make sure that the stack height is below the maximum paper fill indicator.
- Do not slide paper into the tray. Load paper as shown in the illustration.

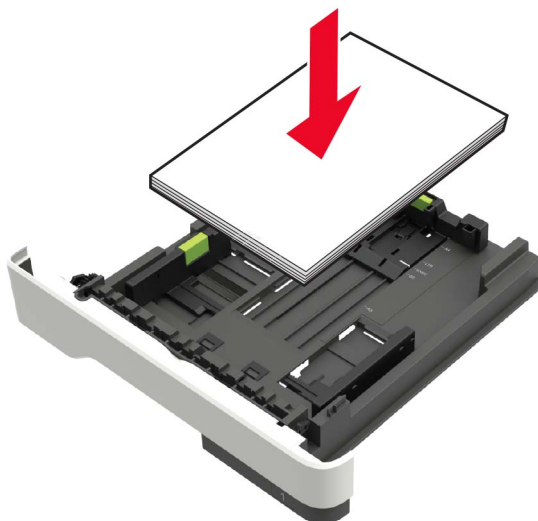

- Make sure that the paper guides are positioned correctly and are not pressing tightly against the paper or envelopes.
- Push the tray firmly into the printer after loading paper.

### Use recommended paper

- Use only recommended paper or specialty media.
- Do not load paper that is wrinkled, creased, damp, bent, or curled.

- Flex, fan, and align the paper edges before loading.

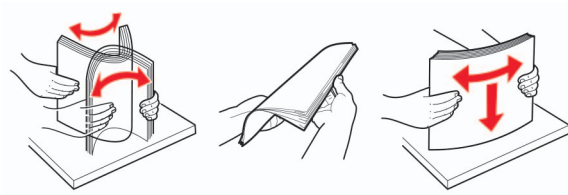

- Do not use paper that has been cut or trimmed by hand.
- Do not mix paper sizes, weights, or types in the same tray.
- Make sure that the paper size and type are set correctly on the computer or printer control panel.
- Store paper according to manufacturer recommendations.

## Identifying jam locations

### Notes:

- When Jam Assist is set to On, the printer automatically flushes blank pages or partially printed pages with after a jammed page is cleared. Check your printed output for blank pages.
- When Jam Recovery is set to On or Auto, the printer reprints jammed pages.

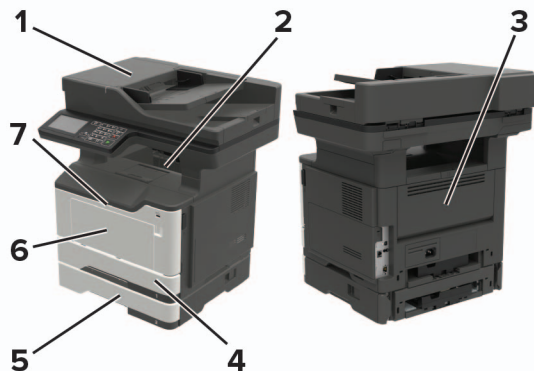

	Jam location
1	Automatic document feeder
2	Standard bin
3	Rear door
4	Standard 250-sheet tray
5	Optional 250- or 550-sheet tray
6	Multipurpose feeder
7	Door A

## Paper jam in door A

1 Remove the tray.



2 Open door A.

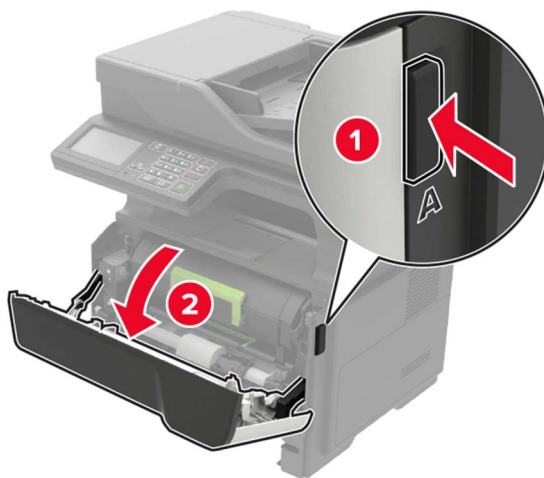



- 3 Remove the toner cartridge.

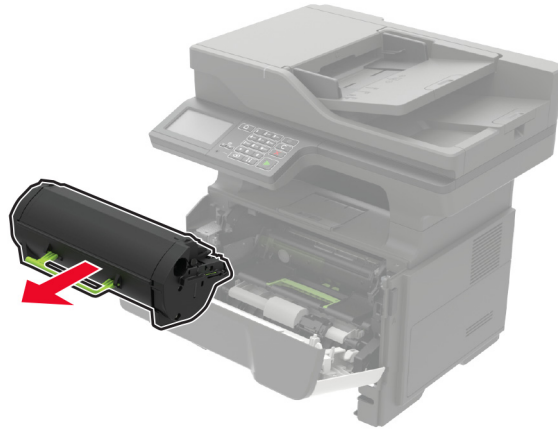

- 4 Remove the imaging unit.

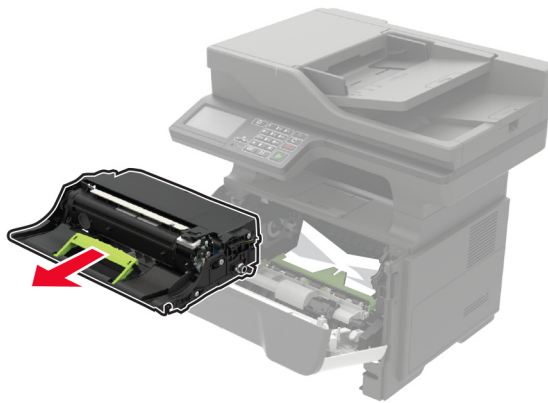

**Warning—Potential Damage:** Do not expose the imaging unit to direct light for more than 10 minutes. Extended exposure to light may cause print quality problems.

**Warning—Potential Damage:** Do not touch the photoconductor drum. Doing so may affect the quality of future print jobs.



5 Remove the jammed paper.

 **CAUTION—HOT SURFACE:** The inside of the printer might be hot. To reduce the risk of injury from a hot component, allow the surface to cool before touching it.

**Note:** Make sure that all paper fragments are removed.

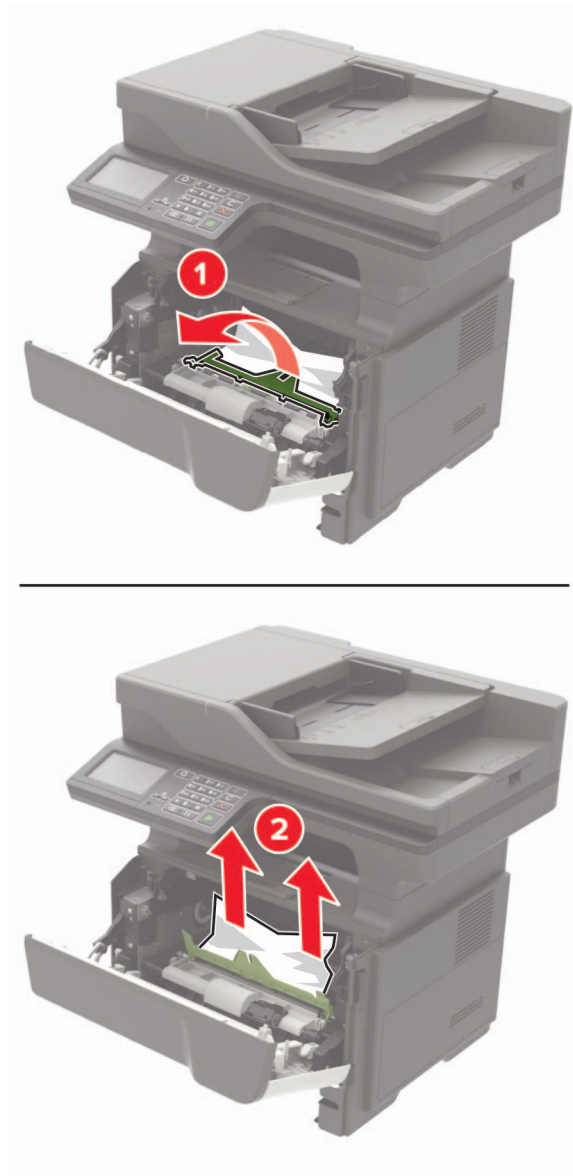

**6** Insert the imaging unit.

**Note:** Use the arrows inside the printer as guides.

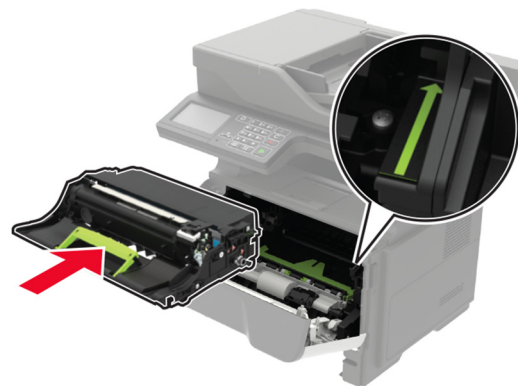

- 7 Insert the toner cartridge.

**Note:** Use the arrows inside the printer as guides.

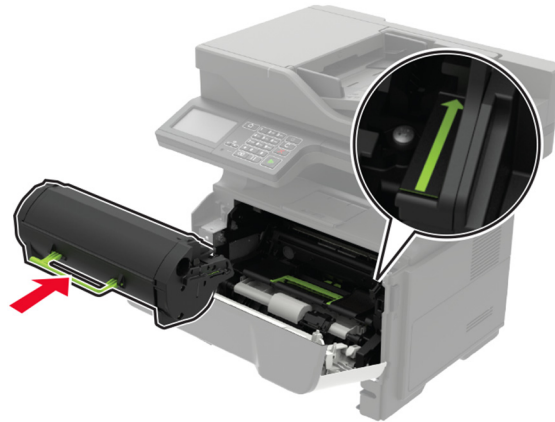

- 8 Close door A.
- 9 Insert the tray.

## Paper jam in the rear door

- 1 Open the rear door.

 **CAUTION—HOT SURFACE:** The inside of the printer might be hot. To reduce the risk of injury from a hot component, allow the surface to cool before touching it.

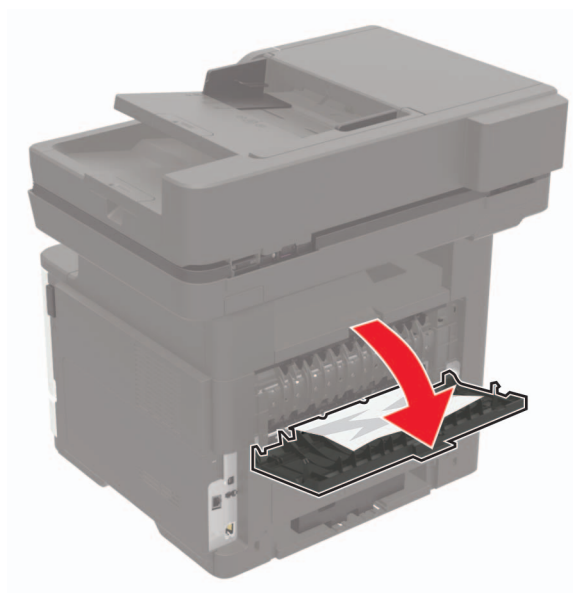

- 2 Remove the jammed paper.

**Note:** Make sure that all paper fragments are removed.

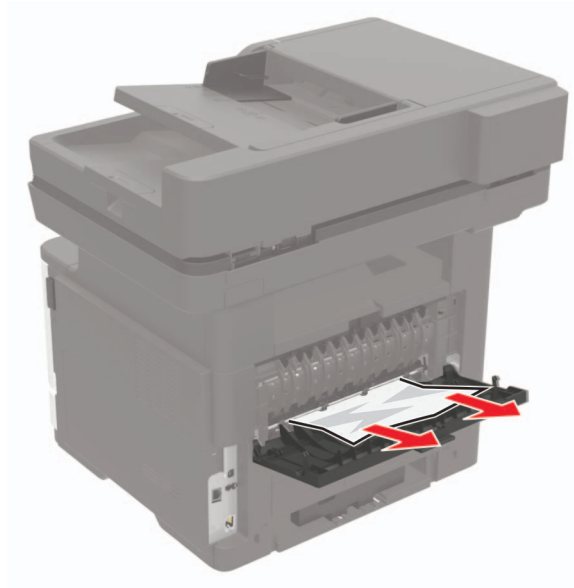

3 Close the rear door.

## Paper jam in the standard bin

Remove the jammed paper.

**Note:** Make sure that all paper fragments are removed.



## Paper jam in the duplex unit

1 Remove the tray.

**Warning—Potential Damage:** To prevent damage from electrostatic discharge, touch the metal plate at the back of the printer where the cables plug in before accessing or touching interior areas of the printer.



**2** Remove the jammed paper.

**Note:** Make sure that all paper fragments are removed.

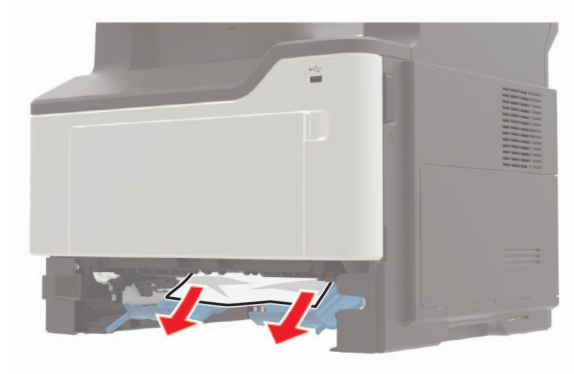

**3** Insert the tray.

## Paper jam in trays

**1** Remove the tray.

**Warning—Potential Damage:** To prevent damage from electrostatic discharge, touch the metal plate at the back of the printer where the cables plug in before accessing or touching interior areas of the printer.



**2** Remove the jammed paper.

**Note:** Make sure that all paper fragments are removed.

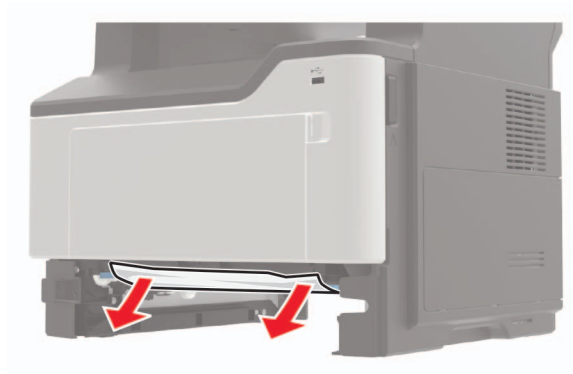

**3** Insert the tray.

## Paper jam in the multipurpose feeder

**1** Remove paper from the multipurpose feeder.

**2** Remove the jammed paper.

**Note:** Make sure that all paper fragments are removed.



**3** Flex, fan, and align the paper edges before loading.

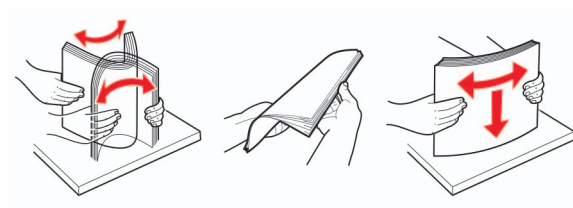

**4** Reload paper, and then adjust the paper guide.



## Paper jam in the automatic document feeder

- 1** Remove all original documents from the ADF tray.
- 2** Open the ADF cover.

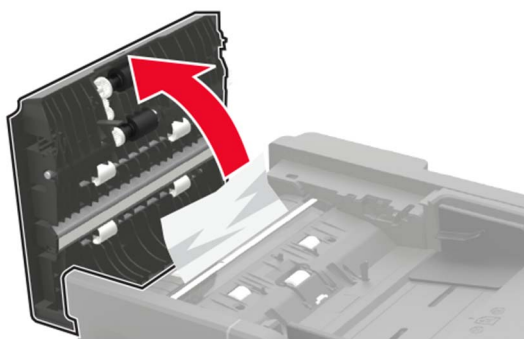

**3** Remove the jammed paper.

**Note:** Make sure that all paper fragments are removed.



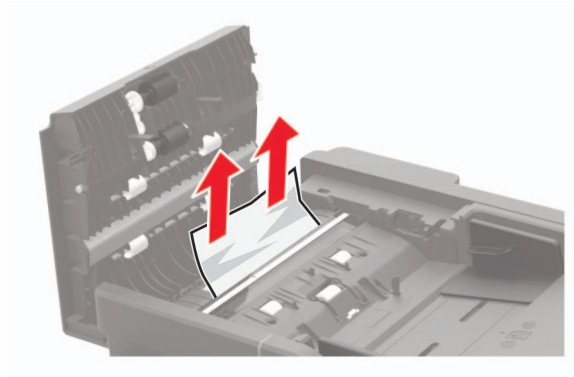

**4** Close the ADF cover.

# Troubleshooting

## Network connection problems

### Cannot open Embedded Web Server

Action	Yes	No
<p><b>Step 1</b> Check if the printer is on.</p> <p>Is the printer on?</p>	Go to step 2.	Turn on the printer.
<p><b>Step 2</b> Make sure that the printer IP address is correct.</p> <p><b>Notes:</b></p> <ul style="list-style-type: none"> <li>• View the IP address on the home screen.</li> <li>• An IP address appears as four sets of numbers separated by periods, such as 123.123.123.123.</li> </ul> <p>Is the printer IP address correct?</p>	Go to step 3.	Type the correct printer IP address in the address field.
<p><b>Step 3</b> Check if you are using a supported browser:</p> <ul style="list-style-type: none"> <li>• Internet Explorer version 11 or later</li> <li>• Microsoft Edge</li> <li>• Safari version 6 or later</li> <li>• Google Chrome™ version 32 or later</li> <li>• Mozilla Firefox version 24 or later</li> </ul> <p>Is your browser supported?</p>	Go to step 4.	Install a supported browser.
<p><b>Step 4</b> Check if the network connection is working.</p> <p>Is the network connection working?</p>	Go to step 5.	Contact your administrator.
<p><b>Step 5</b> Make sure that the cable connections to the printer and print server are secure. For more information, see the documentation that came with the printer.</p> <p>Are the cable connections secure?</p>	Go to step 6.	Secure the cable connections.
<p><b>Step 6</b> Check if the web proxy servers are disabled.</p> <p>Are the web proxy servers disabled?</p>	Go to step 7.	Contact your administrator.

Action	Yes	No
<p><b>Step 7</b> Access the Embedded Web Server.</p> <p>Did the Embedded Web Server open?</p>	The problem is solved.	Contact your <a href="#">dealer</a> .

## Unable to read flash drive

Action	Yes	No
<p><b>Step 1</b> Check if the printer is not busy processing another job.</p> <p>Is the printer ready?</p>	Go to step 2.	Wait for the printer to finish processing the other job.
<p><b>Step 2</b> Check if the flash drive is inserted into the front USB port.</p> <p><b>Note:</b> The flash drive does not work when it is inserted into the rear USB port.</p> <p>Is the flash drive inserted into the correct port?</p>	Go to step 3.	Insert the flash drive into the correct port.
<p><b>Step 3</b> Check if the flash drive is supported. For more information, see <a href="#">“Supported flash drives and file types” on page 30</a>.</p> <p>Is the flash drive supported?</p>	Go to step 4.	Insert a supported flash drive.
<p><b>Step 4</b></p> <p><b>a</b> Check if the USB port is enabled. For more information, see <a href="#">“Enabling the USB port” on page 155</a>.</p> <p><b>b</b> Remove, and then insert the flash drive.</p> <p>Does the printer recognize the flash drive?</p>	The problem is solved.	Contact your <a href="#">dealer</a> .

## Enabling the USB port

From the home screen, touch **Settings** > **Network/Ports** > **USB** > **Enable USB Port**.

## Checking the printer connectivity

- 1 From the home screen, touch **Settings** > **Reports** > **Network** > **Network Setup Page**.
- 2 Check the first section of the network setup page, and confirm that the status is connected.  
If the status is not connected, then the LAN drop may be inactive, or the network cable may be malfunctioning. Contact your administrator for assistance.

## Issues with supplies

### Replace cartridge, printer region mismatch

Install the correct toner cartridge.

### Non-Printer Manufacturer supply

The printer has detected an unrecognized supply or part installed in the printer.

Your printer is designed to function best with genuine supplies and parts made by the printer manufacturer. Use of third-party supplies or parts may affect the performance, reliability, or life of the printer and its imaging components.

All life indicators are designed to function with supplies and parts from the printer manufacturer and may deliver unpredictable results if third-party supplies or parts are used. Imaging component usage beyond the intended life may damage your printer or associated components.

**Warning—Potential Damage:** Use of third-party supplies or parts can affect warranty coverage. Damage caused by the use of third-party supplies or parts may not be covered by the warranty.

To accept any and all of these risks and to proceed with the use of non-genuine supplies or parts in your printer, from the control panel, press and hold **X** and **#** simultaneously for 15 seconds.

If you do not want to accept these risks, then remove the third-party supply or part from your printer and install a genuine supply or part from the printer manufacturer.

### Scanner maintenance required, use ADF Kit

The printer is scheduled for maintenance. Contact customer support or your service representative, and then report the message.

## Paper feed problems

### Envelope seals when printing

Action	Yes	No
<p><b>Step 1</b></p> <p><b>a</b> Use an envelope that has been stored in a dry environment.  <b>Note:</b> Printing on envelopes with high moisture content can seal the flaps.</p> <p><b>b</b> Send the print job.</p> <p>Does the envelope seal when printing?</p>	Go to step 2.	The problem is solved.

Action	Yes	No
<p><b>Step 2</b></p> <p><b>a</b> Make sure that the paper type is set to Envelope. From the control panel, touch <b>Settings &gt; Paper &gt; Tray Configuration &gt; Paper Size/Type</b> &gt; select a paper source</p> <p><b>b</b> Send the print job.</p> <p>Does the envelope seal when printing?</p>	Contact your <a href="#">dealer</a> .	The problem is solved.

### Collated printing does not work

Action	Yes	No
<p><b>Step 1</b></p> <p><b>a</b> From the control panel, touch <b>Settings &gt; Print &gt; Layout &gt; Collate &gt; On [1,2,1,2,1,2]</b>.</p> <p><b>b</b> Print the document.</p> <p>Are the pages collated correctly?</p>	The problem is solved.	Go to step 2.
<p><b>Step 2</b></p> <p><b>a</b> From the document that you are trying to print, open the Print dialog, and then select <b>Collate</b>.</p> <p><b>b</b> Print the document.</p> <p>Are the pages collated correctly?</p>	The problem is solved.	Go to step 3.
<p><b>Step 3</b></p> <p><b>a</b> Reduce the number of pages to print.</p> <p><b>b</b> Print the document.</p> <p>Are the pages collated correctly?</p>	The problem is solved.	Contact your <a href="#">dealer</a> .

### Tray linking does not work

Action	Yes	No
<p><b>Step 1</b></p> <p><b>a</b> Check if the trays contain the same paper size and paper type.</p> <p><b>b</b> Check if the paper guides are positioned correctly.</p> <p><b>c</b> Print the document.</p> <p>Do the trays link correctly?</p>	The problem is solved.	Go to step 2.

Action	Yes	No
<p><b>Step 2</b></p> <p><b>a</b> From the home screen, touch <b>Settings &gt; Paper &gt; Tray Configuration &gt; Paper Size/Type</b>.</p> <p><b>b</b> Set the paper size and paper type to match the paper loaded in the linked trays.</p> <p><b>c</b> Print the document.</p> <p>Do the trays link correctly?</p>	<p>The problem is solved.</p>	<p>Go to step 3.</p>
<p><b>Step 3</b></p> <p><b>a</b> Make sure that Tray Linking is set to Automatic. For more information, see <a href="#">“Linking trays” on page 23</a>.</p> <p><b>b</b> Print the document.</p> <p>Do the trays link correctly?</p>	<p>The problem is solved.</p>	<p>Contact your <a href="#">dealer</a>.</p>

### Paper frequently jams

Action	Yes	No
<p><b>Step 1</b></p> <p><b>a</b> Pull out the tray.</p> <p><b>b</b> Check if paper is loaded correctly.</p> <p><b>Notes:</b></p> <ul style="list-style-type: none"> <li>• Make sure that the paper guides are positioned correctly.</li> <li>• Make sure that the stack height is below the maximum paper fill indicator.</li> <li>• Make sure to print on recommended paper size and type.</li> </ul> <p><b>c</b> Insert the tray.</p> <p><b>d</b> Print the document.</p> <p>Do paper jams occur frequently?</p>	<p>Go to step 2.</p>	<p>The problem is solved.</p>
<p><b>Step 2</b></p> <p><b>a</b> From the home screen, touch <b>Settings &gt; Paper &gt; Tray Configuration &gt; Paper Size/Type</b>.</p> <p><b>b</b> Set the correct paper size and type.</p> <p><b>c</b> Print the document.</p> <p>Do paper jams occur frequently?</p>	<p>Go to step 3.</p>	<p>The problem is solved.</p>

Action	Yes	No
<p><b>Step 3</b></p> <p><b>a</b> Load paper from a fresh package.</p> <p><b>Note:</b> Paper absorbs moisture due to high humidity. Store paper in its original wrapper until you are ready to use it.</p> <p><b>b</b> Print the document.</p> <p>Do paper jams occur frequently?</p>	Contact your <a href="#">dealer</a> .	The problem is solved.

### Jammed pages are not reprinted

Action	Yes	No
<p><b>a</b> From the home screen, touch <b>Settings &gt; Device &gt; Notifications &gt; Jam Content Recovery</b>.</p> <p><b>b</b> In the Jam Recovery menu, select <b>On</b> or <b>Auto</b>.</p> <p><b>c</b> Print the document.</p> <p>Are the jammed pages reprinted?</p>	The problem is solved.	Contact your <a href="#">dealer</a> .

## Printing problems

### Confidential and other held documents do not print

Action	Yes	No
<p><b>Step 1</b></p> <p><b>a</b> From the control panel, check if the documents appear in the Held Jobs list.</p> <p><b>Note:</b> If the documents are not listed, then print the documents using the Print and Hold options.</p> <p><b>b</b> Print the documents.</p> <p>Are the documents printed?</p>	The problem is solved.	Go to step 2.
<p><b>Step 2</b></p> <p>The print job may contain a formatting error or invalid data. Delete the print job, and then send it again.</p> <p>Are the documents printed?</p>	The problem is solved.	Go to step 3.

Action	Yes	No
<p><b>Step 3</b></p> <p>If you are printing from the Internet, then the printer may be reading the multiple job titles as duplicates.</p> <p><b>For Windows users</b></p> <ul style="list-style-type: none"> <li><b>a</b> Open the Printing Preferences dialog.</li> <li><b>b</b> From the Print and Hold tab, click <b>Use Print and Hold</b>, and then click <b>Keep duplicate documents</b>.</li> <li><b>c</b> Enter a PIN, and then save the changes.</li> <li><b>d</b> Send the print job.</li> </ul> <p><b>For Macintosh users</b></p> <ul style="list-style-type: none"> <li><b>a</b> Save and name each job differently.</li> <li><b>b</b> Send the job individually.</li> </ul> <p>Are the documents printed?</p>	<p>The problem is solved.</p>	<p>Go to step 4.</p>
<p><b>Step 4</b></p> <ul style="list-style-type: none"> <li><b>a</b> Delete some held jobs to free up printer memory.</li> <li><b>b</b> Print the documents.</li> </ul> <p>Are the documents printed?</p>	<p>The problem is solved.</p>	<p>Contact your <a href="#">dealer</a>.</p>

## Slow printing

Action	Yes	No
<p><b>Step 1</b></p> <ul style="list-style-type: none"> <li><b>a</b> Connect the printer cable securely to the printer and the computer, print server, option, or other network device.</li> <li><b>b</b> Print the document.</li> </ul> <p>Is the printer printing slow?</p>	<p>Go to step 2.</p>	<p>The problem is solved.</p>
<p><b>Step 2</b></p> <ul style="list-style-type: none"> <li><b>a</b> Make sure that the printer is not in Quiet Mode. From the home screen, touch <b>Settings &gt; Device &gt; Maintenance &gt; Configuration Menu &gt; Device Operations &gt; Quiet Mode</b>.</li> <li><b>b</b> Print the document.</li> </ul> <p>Is the printer printing slow?</p>	<p>Go to step 3.</p>	<p>The problem is solved.</p>



Action	Yes	No
<p><b>Step 3</b></p> <p><b>a</b> Depending on your operating system, specify the paper type from the Printing Preferences or Print dialog.</p> <p><b>Notes:</b></p> <ul style="list-style-type: none"> <li>• Make sure that the setting matches the paper loaded in the tray.</li> <li>• You can also change the setting from the printer control panel. From the home screen, touch <b>Settings &gt; Paper &gt; Tray Configuration &gt; Paper Size/Type</b>.</li> </ul> <p><b>b</b> Print the document.</p> <p>Is the printer printing slow?</p>	<p>Go to step 4.</p>	<p>The problem is solved.</p>
<p><b>Step 4</b></p> <p><b>a</b> Reduce the number of pages to print.</p> <p><b>b</b> Print the document.</p> <p>Is the printer printing slow?</p>	<p>Go to step 5.</p>	<p>The problem is solved.</p>
<p><b>Step 5</b></p> <p><b>a</b> From the home screen, touch <b>Settings &gt; Print &gt; Quality &gt; Print Resolution</b>.</p> <p><b>b</b> Set the resolution to <b>600 dpi</b>.</p> <p><b>c</b> Print the document.</p> <p>Is the printer still printing slow?</p>	<p>Go to step 6.</p>	<p>The problem is solved.</p>
<p><b>Step 6</b></p> <p><b>a</b> Make sure that the printer is not overheating.</p> <p><b>Notes:</b></p> <ul style="list-style-type: none"> <li>• Allow the printer to cool down after a long print job.</li> <li>• Observe the recommended ambient temperature for the printer. For more information, see <a href="#">“Selecting a location for the printer” on page 9</a>.</li> </ul> <p><b>b</b> Print the document.</p> <p>Is the printer still printing slow?</p>	<p>Contact your <a href="#">dealer</a>.</p>	<p>The problem is solved.</p>

## Print jobs do not print

Action	Yes	No
<p><b>Step 1</b></p> <p><b>a</b> From the document you are trying to print, open the Print dialog, and then check if you have selected the correct printer.</p> <p><b>b</b> Print the document.</p> <p>Is the document printed?</p>	The problem is solved.	Go to step 2.
<p><b>Step 2</b></p> <p><b>a</b> Check if the printer is on.</p> <p><b>b</b> Resolve any error messages that appear on the display.</p> <p><b>c</b> Print the document.</p> <p>Is the document printed?</p>	The problem is solved.	Go to step 3.
<p><b>Step 3</b></p> <p><b>a</b> Check if the ports are working and if the cables are securely connected to the computer and the printer. For more information, see the setup documentation that came with the printer.</p> <p><b>b</b> Print the document.</p> <p>Is the document printed?</p>	The problem is solved.	Go to step 4.
<p><b>Step 4</b></p> <p><b>a</b> Turn off the printer, wait for about 10 seconds, and then turn on the printer.</p> <p><b>b</b> Print the document.</p> <p>Is the document printed?</p>	The problem is solved.	Go to step 5.
<p><b>Step 5</b></p> <p><b>a</b> Remove, and then reinstall the print driver.</p> <p><b>b</b> Print the document.</p> <p>Is the document printed?</p>	The problem is solved.	Contact your <a href="#">dealer</a> .

## Print quality is poor

### Blank or white pages



Contact your [dealer](#).

### Dark print



**Note:** Before solving the problem, print the Print Quality Test Pages. From the control panel, navigate to **Settings > Troubleshooting > Print Quality Test Pages**. For non-touch-screen printer models, press **OK** to navigate through the settings.

Action	Yes	No
<p><b>Step 1</b></p> <p><b>a</b> Check if the printer is using a genuine and supported toner cartridge.</p> <p><b>Note:</b> If the cartridge is not supported, then install a supported one.</p> <p><b>b</b> Print the document.</p> <p>Is the print dark?</p>	Go to step 2.	The problem is solved.
<p><b>Step 2</b></p> <p><b>a</b> Turn off the printer, wait for about 10 seconds, and then turn on the printer.</p> <p><b>b</b> Reduce toner darkness. From the control panel, navigate to: <b>Settings &gt; Print &gt; Quality</b></p> <p><b>c</b> Print the document.</p> <p>Is the print dark?</p>	Go to step 3.	The problem is solved.

Action	Yes	No
<p><b>Step 3</b></p> <p><b>a</b> Depending on your operating system, specify the paper type from the Printing Preferences or Print dialog.</p> <p><b>Notes:</b></p> <ul style="list-style-type: none"> <li>• Make sure that the setting matches the paper loaded.</li> <li>• You can also change the setting on the printer control panel. From the control panel, navigate to <b>Settings &gt; Paper &gt; Tray Configuration &gt; Paper Size/Type</b>.</li> </ul> <p><b>b</b> Print the document.</p> <p>Is the print dark?</p>	Go to step 4.	The problem is solved.
<p><b>Step 4</b></p> <p>Check if the paper has texture or rough finishes.</p> <p>Are you printing on textured or rough paper?</p>	Go to step 5.	Go to step 6.
<p><b>Step 5</b></p> <p><b>a</b> Replace textured paper with plain paper.</p> <p><b>b</b> Print the document.</p> <p>Is the print dark?</p>	Go to step 6.	The problem is solved.
<p><b>Step 6</b></p> <p><b>a</b> Load paper from a fresh package.</p> <p><b>Note:</b> Paper absorbs moisture due to high humidity. Store paper in its original wrapper until you are ready to use it.</p> <p><b>b</b> Print the document.</p> <p>Is the print dark?</p>	Go to step 7.	The problem is solved.
<p><b>Step 7</b></p> <p><b>a</b> Remove, and then insert the imaging unit.</p> <p><b>Warning—Potential Damage:</b> Do not expose the imaging unit to direct light for more than 10 minutes. Extended exposure to light may cause print quality problems.</p> <p><b>Warning—Potential Damage:</b> Do not touch the photoconductor drum under the imaging unit. Doing so may affect the quality of future print jobs.</p> <p><b>b</b> Print the document.</p> <p>Is the print dark?</p>	Contact your <a href="#">dealer</a> .	The problem is solved.

### Fine lines are not printed correctly

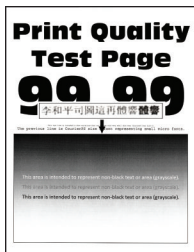

**Note:** Before solving the problem, print the Print Quality Test Pages. From the control panel, navigate to **Settings > Troubleshooting > Print Quality Test Pages**. For non-touch-screen printer models, press **OK** to navigate through the settings.

Action	Yes	No
<p><b>Step 1</b></p> <p><b>a</b> Check if the printer is using a genuine and supported toner cartridge.</p> <p><b>Note:</b> If the cartridge is not supported, then install a supported one.</p> <p><b>b</b> Print the document.</p> <p>Are fine lines not printed correctly?</p>	Go to step 2.	The problem is solved.
<p><b>Step 2</b></p> <p><b>a</b> Adjust the print quality settings.</p> <p><b>1</b> From the control panel, navigate to: <b>Settings &gt; Print &gt; Quality &gt; Pixel Boost &gt; Fonts</b></p> <p><b>2</b> Adjust Toner Darkness to 7. From the control panel, navigate to: <b>Settings &gt; Print &gt; Quality</b></p> <p><b>b</b> Print the document.</p> <p>Are fine lines not printed correctly?</p>	Contact your <a href="#">dealer</a> .	The problem is solved.

### Folded or wrinkled paper

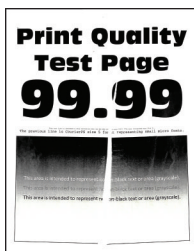

**Note:** Before solving the problem, print the Print Quality Test Pages. From the control panel, navigate to **Settings > Troubleshooting > Print Quality Test Pages**. For non-touch-screen printer models, press **OK** to navigate through the settings.

Action	Yes	No
<p><b>Step 1</b></p> <p><b>a</b> Check if the printer is using a genuine and supported toner cartridge.</p> <p><b>Note:</b> If the cartridge is not supported, then install a supported one.</p> <p><b>b</b> Print the document.</p> <p>Is the paper folded or wrinkled?</p>	Go to step 2.	The problem is solved.
<p><b>Step 2</b></p> <p><b>a</b> Load paper from a fresh package.</p> <p><b>Note:</b> Paper absorbs moisture due to high humidity. Store paper in its original wrapper until you are ready to use it.</p> <p><b>b</b> Print the document.</p> <p>Is the paper folded or wrinkled?</p>	Go to step 3.	The problem is solved.
<p><b>Step 3</b></p> <p><b>a</b> Depending on your operating system, specify the paper type from the Printing Preferences or Print dialog.</p> <p><b>Notes:</b></p> <ul style="list-style-type: none"> <li>• Make sure that the setting matches the paper loaded.</li> <li>• You can also change the setting on the printer control panel. Navigate to <b>Settings &gt; Paper &gt; Tray Configuration &gt; Paper Size/Type</b>.</li> </ul> <p><b>b</b> Print the document.</p> <p>Is the paper folded or wrinkled?</p>	Contact your <a href="#">dealer</a> .	The problem is solved.

### Gray background

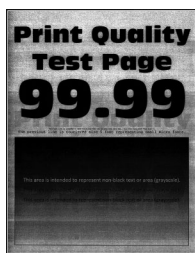

**Note:** Before solving the problem, print the Print Quality Test Pages. From the control panel, navigate to **Settings > Troubleshooting > Print Quality Test Pages**. For non-touch-screen printer models, press **OK** to navigate through the settings.

Action	Yes	No
<p><b>Step 1</b></p> <p><b>a</b> Turn off the printer, wait for 10 seconds, and then turn on the printer.</p> <p><b>b</b> Decrease toner darkness. From the control panel, navigate to: <b>Settings &gt; Print &gt; Quality &gt; Toner Darkness</b></p> <p><b>c</b> Print the document.</p> <p>Does gray background appear on prints?</p>	Go to step 2.	The problem is solved.
<p><b>Step 2</b></p> <p><b>a</b> Check if the printer is using a genuine and supported toner cartridge. <b>Note:</b> If the toner cartridge is not supported, then install a supported one.</p> <p><b>b</b> Print the document.</p> <p>Does gray background appear on prints?</p>	Go to step 3.	The problem is solved.
<p><b>Step 3</b></p> <p><b>a</b> Depending on your operating system, specify the paper type from the Printing Preferences or Print dialog. <b>Notes:</b></p> <ul style="list-style-type: none"> <li>• Make sure that the setting matches the paper loaded.</li> <li>• You can also change the setting on the printer control panel. Navigate to <b>Settings &gt; Paper &gt; Tray Configuration &gt; Paper Size/Type</b>.</li> </ul> <p><b>b</b> Print the document.</p> <p>Does gray background appear on prints?</p>	Contact your <a href="#">dealer</a> .	The problem is solved.

### Horizontal light bands



**Note:** Before solving the problem, print the Print Quality Test Pages. From the control panel, navigate to **Settings > Troubleshooting > Print Quality Test Pages**. For non-touch-screen printer models, press  to navigate through the settings.

Action	Yes	No
<p><b>a</b> Check if the printer is using a genuine and supported toner cartridge.</p> <p><b>Note:</b> If the cartridge is not supported, then install a supported one.</p> <p><b>b</b> Print the document.</p> <p>Do horizontal light bands appear on prints?</p>	Contact your <a href="#">dealer</a> .	The problem is solved.

### Incorrect margins



**Note:** Before solving the problem, print the Print Quality Test Pages. From the control panel, navigate to **Settings > Troubleshooting > Print Quality Test Pages**. For non-touch-screen printer models, press **OK** to navigate through the settings.

Action	Yes	No
<p><b>Step 1</b></p> <p><b>a</b> Adjust the paper guides to the correct position for the paper loaded.</p> <p><b>b</b> Print the document.</p> <p>Are the margins correct?</p>	The problem is solved.	Go to step 2.
<p><b>Step 2</b></p> <p><b>a</b> Depending on your operating system, specify the paper size from the Printing Preferences or Print dialog.</p> <p><b>Notes:</b></p> <ul style="list-style-type: none"> <li>• Make sure that the setting matches the paper loaded.</li> <li>• You can also change the setting from the printer control panel. Navigate to <b>Settings &gt; Paper &gt; Tray Configuration &gt; Paper Size/Type</b>.</li> </ul> <p><b>b</b> Print the document.</p> <p>Are the margins correct?</p>	The problem is solved.	Contact your <a href="#">dealer</a> .



## Light print

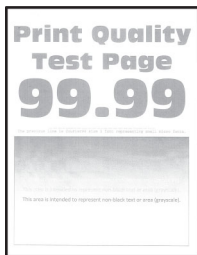

**Note:** Before solving the problem, print the Print Quality Test Pages. From the control panel, navigate to **Settings > Troubleshooting > Print Quality Test Pages**. For non-touch-screen printer models, press **OK** to navigate through the settings.

Action	Yes	No
<p><b>Step 1</b></p> <p><b>a</b> Check if the printer is using a genuine and supported toner cartridge.</p> <p><b>Note:</b> If the cartridge is not supported, then install a supported one.</p> <p><b>b</b> Print the document.</p> <p>Is the print light?</p>	Go to step 2.	The problem is solved.
<p><b>Step 2</b></p> <p><b>a</b> Turn off the printer, wait for about 10 seconds, and then turn on the printer.</p> <p><b>b</b> Increase toner darkness. From the control panel, navigate to: <b>Settings &gt; Print &gt; Quality &gt; Toner Darkness</b></p> <p><b>c</b> Print the document.</p> <p>Is the print light?</p>	Go to step 3.	The problem is solved.
<p><b>Step 3</b></p> <p><b>a</b> Depending on your operating system, specify the paper type from the Printing Preferences or Print dialog.</p> <p><b>Notes:</b></p> <ul style="list-style-type: none"> <li>• Make sure that the setting matches the paper loaded.</li> <li>• You can also change the setting on the printer control panel. Navigate to <b>Settings &gt; Paper &gt; Tray Configuration &gt; Paper Size/Type</b></li> </ul> <p><b>b</b> Print the document.</p> <p>Is the print light?</p>	Go to step 4.	The problem is solved.

Action	Yes	No
<p><b>Step 4</b>                      Check if the print resolution is set to 600 dpi.  <b>a</b> From the control panel, navigate to:                          <b>Settings &gt; Print &gt; Quality &gt; Print Resolution</b>  <b>b</b> Print the document.</p> <p>Is the print light?</p>	Go to step 5.	The problem is solved.
<p><b>Step 5</b>                      Check the status of the toner cartridge, and replace if necessary.  <b>a</b> From the control panel, navigate to:                          <b>Status/Supplies &gt; Supplies</b>  <b>b</b> Print the document.</p> <p>Is the print light?</p>	Contact your <a href="#">dealer</a> .	The problem is solved.

**Mottled print and dots**



**Note:** Before solving the problem, print the Print Quality Test Pages. From the control panel, navigate to **Settings > Troubleshooting > Print Quality Test Pages**. For non-touch-screen printer models, press  to navigate through the settings.

Action	Yes	No
<p><b>Step 1</b>  <b>a</b> Check if the printer is using a genuine and supported toner cartridge.                          <b>Note:</b> If the cartridge is not supported, then install a supported one.  <b>b</b> Print the document.</p> <p>Is the print mottled?</p>	Go to step 2.	The problem is solved.
<p><b>Step 2</b>                      Check the printer for leaked toner contamination.</p> <p>Is the printer free of leaked toner?</p>	Go to step 3.	Contact your <a href="#">dealer</a> .

Action	Yes	No
<p><b>Step 3</b></p> <p><b>a</b> Check the status of the imaging unit. From the control panel, navigate to: <b>Settings &gt; Reports &gt; Device &gt; Device Statistics</b></p> <p><b>b</b> From the Supply Information section of the pages printed, check the status of the imaging unit.</p> <p>Is the imaging unit near end of life?</p>	Go to step 4.	Contact your <a href="#">dealer</a> .
<p><b>Step 4</b></p> <p><b>a</b> Replace the imaging unit.</p> <p><b>b</b> Print the document.</p> <p>Is the print mottled?</p>	Contact your <a href="#">dealer</a> .	The problem is solved.

**Paper curl**



Action	Yes	No
<p><b>Step 1</b></p> <p><b>a</b> Check if the paper loaded is supported. <b>Note:</b> If paper is not supported, then load a supported paper.</p> <p><b>b</b> Print the document.</p> <p>Is the paper curled?</p>	Go to step 2.	The problem is solved.
<p><b>Step 2</b></p> <p><b>a</b> Check if the printer is using a genuine and supported toner cartridge. <b>Note:</b> If the cartridge is not supported, then install a supported one.</p> <p><b>b</b> Print the document.</p> <p>Is the paper curled?</p>	Go to step 3.	The problem is solved.

Action	Yes	No
<p><b>Step 3</b></p> <p><b>a</b> Adjust the guides in the tray to the correct position for the paper loaded.</p> <p><b>b</b> Print the document.</p> <p>Is the paper curled?</p>	Go to step 4.	The problem is solved.
<p><b>Step 4</b></p> <p><b>a</b> Depending on your operating system, specify the paper size and paper type from the Printing Preferences or Print dialog.</p> <p><b>Notes:</b></p> <ul style="list-style-type: none"> <li>• Make sure that the settings match the paper loaded.</li> <li>• You can also change the settings on the printer control panel. Navigate to <b>Settings &gt; Paper &gt; Tray Configuration &gt; Paper Size/Type</b>. For non-touch-screen printer models, press  to navigate through the settings.</li> </ul> <p><b>b</b> Print the document.</p> <p>Is the paper curled?</p>	Go to step 5.	The problem is solved.
<p><b>Step 5</b></p> <p><b>a</b> Remove paper, flip it over, and then reload paper.</p> <p><b>b</b> Print the document.</p> <p>Is the paper curled?</p>	Go to step 6.	The problem is solved.
<p><b>Step 6</b></p> <p><b>a</b> Load paper from a fresh package.</p> <p><b>Note:</b> Paper absorbs moisture due to high humidity. Store paper in its original wrapper until you are ready to use it.</p> <p><b>b</b> Print the document.</p> <p>Is the paper curled?</p>	Contact your <a href="#">dealer</a> .	The problem is solved.

**Print crooked or skewed**



**Note:** Before solving the problem, print the Print Quality Test Pages. From the control panel, navigate to **Settings > Troubleshooting > Print Quality Test Pages**. For non-touch-screen printer models, press **OK** to navigate through the settings.

Action	Yes	No
<p><b>Step 1</b></p> <p><b>a</b> Adjust the paper guides in the tray to the correct position for the paper loaded.</p> <p><b>b</b> Print the document.</p> <p>Is the print crooked or skewed?</p>	Go to step 2.	The problem is solved.
<p><b>Step 2</b></p> <p><b>a</b> Load paper from a fresh package.</p> <p><b>Note:</b> Paper absorbs moisture due to high humidity. Store paper in its original wrapper until you are ready to use it.</p> <p><b>b</b> Print the document.</p> <p>Is the print crooked or skewed?</p>	Go to step 3.	The problem is solved.
<p><b>Step 3</b></p> <p><b>a</b> Check if the paper loaded is supported.</p> <p><b>Note:</b> If paper is not supported, then load a supported paper.</p> <p><b>b</b> Print the document.</p> <p>Is the print crooked or skewed?</p>	Contact your <a href="#">dealer</a> .	The problem is solved.

### Repeating defects

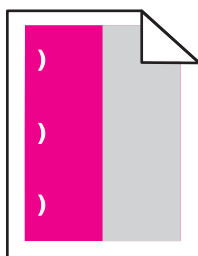

Contact your [dealer](#).

### Solid black pages

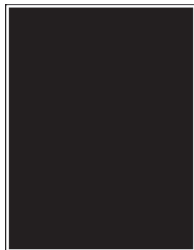

**Note:** Before solving the problem, print the Print Quality Test Pages. From the control panel, navigate to **Settings > Troubleshooting > Print Quality Test Pages**. For non-touch-screen printer models, press **OK** to navigate through the settings.

Action	Yes	No
<p><b>a</b> Check if the printer is using a genuine and supported toner cartridge.</p> <p><b>Note:</b> If the toner cartridge is not supported, then install a supported one.</p> <p><b>b</b> Print the document.</p> <p>Is the printer printing solid black pages?</p>	Contact your <a href="#">dealer</a> .	The problem is solved.

### Text or images cut off

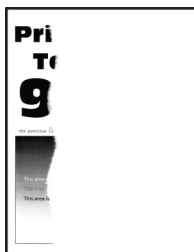

**Note:** Before solving the problem, print the Print Quality Test Pages. From the control panel, navigate to **Settings > Troubleshooting > Print Quality Test Pages**. For non-touch-screen printer models, press **OK** to navigate through the settings.

Action	Yes	No
<p><b>a</b> Check if the printer is using a genuine and supported toner cartridge.</p> <p><b>Note:</b> If the toner cartridge is not supported, then install a supported one.</p> <p><b>b</b> Print the document.</p> <p>Are text or images cut off?</p>	Contact your <a href="#">dealer</a> .	The problem is solved.

### Toner easily rubs off



**Note:** Before solving the problem, print the Print Quality Test Pages. From the control panel, navigate to

**Settings > Troubleshooting > Print Quality Test Pages.** For non-touch-screen printer models, press **OK** to navigate through the settings.

Action	Yes	No
<p><b>Step 1</b></p> <p><b>a</b> Check if the printer is using a genuine and supported toner cartridge.</p> <p><b>Note:</b> If the cartridge is not supported, then install a supported one.</p> <p><b>b</b> Print the document.</p> <p>Does toner easily rub off?</p>	<p>Go to step 2.</p>	<p>The problem is solved.</p>
<p><b>Step 2</b></p> <p><b>a</b> Depending on your operating system, specify the paper type from the Printing Preferences or Print dialog.</p> <p><b>Notes:</b></p> <ul style="list-style-type: none"> <li>• Make sure that the setting matches the paper loaded.</li> <li>• You can also change the setting on the printer control panel. Navigate to <b>Settings &gt; Paper &gt; Tray Configuration &gt; Paper Size/Type.</b></li> </ul> <p><b>b</b> Print the document.</p> <p>Does toner easily rub off?</p>	<p>Contact your <a href="#">dealer</a>.</p>	<p>The problem is solved.</p>

### Vertical dark bands

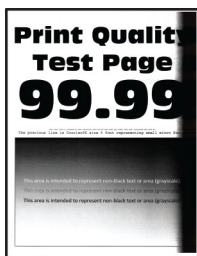

**Note:** Before solving the problem, print the Print Quality Test Pages. From the control panel, navigate to **Settings > Troubleshooting > Print Quality Test Pages**. For non-touch-screen printer models, press **OK** to navigate through the settings.

Action	Yes	No
<p><b>a</b> Check if the printer is using a genuine and supported toner cartridge.</p> <p><b>Note:</b> If the toner cartridge is not supported, then install a supported one.</p> <p><b>b</b> Print the document.</p> <p>Do vertical dark bands appear on prints?</p>	Contact your <a href="#">dealer</a> .	The problem is solved.

### Vertical dark lines or streaks



Action	Yes	No
<p><b>Step 1</b></p> <p><b>a</b> From the control panel, navigate to: <b>Settings &gt; Troubleshooting &gt; Cleaning the scanner</b></p> <p><b>b</b> Print the document.</p> <p>Do vertical dark lines or streaks appear on prints?</p>	Go to step 2.	The problem is solved.
<p><b>Step 2</b></p> <p><b>a</b> Using a damp, soft, lint-free cloth, clean the scanner. For more information, see <a href="#">“Cleaning the scanner” on page 125</a>.</p> <p><b>b</b> Copy the document using the ADF.</p> <p>Do vertical dark lines or streaks appear on prints?</p>	Go to step 3.	The problem is solved.
<p><b>Step 3</b></p> <p><b>a</b> Check if the printer is using a genuine and supported toner cartridge.</p> <p><b>Note:</b> If the toner cartridge is not supported, then install a supported one.</p> <p><b>b</b> Print the document.</p> <p>Do vertical dark lines or streaks appear on prints?</p>	Contact your <a href="#">dealer</a> .	The problem is solved.



### Vertical dark streaks with print missing

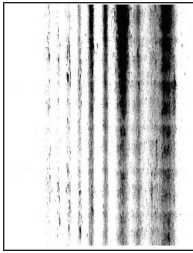

Contact your [dealer](#).

### Vertical light bands



**Note:** Before solving the problem, print the Print Quality Test Pages. From the control panel, navigate to **Settings > Troubleshooting > Print Quality Test Pages**. For non-touch-screen printer models, press  to navigate through the settings.

Action	Yes	No
<p><b>a</b> Check if the printer is using a genuine and supported toner cartridge.</p> <p><b>Note:</b> If the cartridge is not supported, then install a supported one.</p> <p><b>b</b> Print the document.</p> <p>Do vertical light bands appear on prints?</p>	Contact your <a href="#">dealer</a> .	The problem is solved.

### Vertical white lines



**Note:** Before solving the problem, print the Print Quality Test Pages. From the control panel, navigate to **Settings > Troubleshooting > Print Quality Test Pages**. For non-touch-screen printer models, press  to navigate through the settings.

Action	Yes	No
<p><b>Step 1</b></p> <p><b>a</b> Check if the printer is using a genuine and supported toner cartridge.</p> <p><b>Note:</b> If the cartridge is not supported, then install a supported one.</p> <p><b>b</b> Print the document.</p> <p>Do vertical white lines appear on prints?</p>	Go to step 2.	The problem is solved.
<p><b>Step 2</b></p> <p>Fix slow printing problems. For more information, see <a href="#">“Slow printing” on page 160</a>.</p> <p>Do vertical white lines appear on prints?</p>	Contact your <a href="#">dealer</a> .	The problem is solved.

### The printer is not responding

Action	Yes	No
<p><b>Step 1</b></p> <p>Check if the power cord is connected to the electrical outlet.</p> <p> <b>CAUTION—POTENTIAL INJURY:</b> To avoid the risk of fire or electrical shock, connect the power cord to an appropriately rated and properly grounded electrical outlet that is near the product and easily accessible.</p> <p>Is the printer responding?</p>	The problem is solved.	Go to step 2.
<p><b>Step 2</b></p> <p>Check if the electrical outlet is turned off by a switch or breaker.</p> <p>Is the electrical outlet turned off by a switch or breaker?</p>	Turn on the switch or reset the breaker.	Go to step 3.
<p><b>Step 3</b></p> <p>Check if the printer is on.</p> <p>Is the printer on?</p>	Go to step 4.	Turn on the printer.
<p><b>Step 4</b></p> <p>Check if the printer is in Sleep or Hibernate mode.</p> <p>Is the printer in Sleep or Hibernate mode?</p>	Press the power button to wake the printer.	Go to step 5.

Action	Yes	No
<p><b>Step 5</b> Check if the cables connecting the printer and the computer are inserted to the correct ports.</p> <p>Are the cables inserted to the correct ports?</p>	Go to step 6.	Insert the cables to the correct ports.
<p><b>Step 6</b> Install the correct print driver.</p> <p>Is the printer responding?</p>	The problem is solved.	Go to step 7.
<p><b>Step 7</b> Turn off the printer, wait for about 10 seconds, and then turn on the printer.</p> <p>Is the printer responding?</p>	The problem is solved.	Contact your <a href="#">dealer</a> .

## Adjusting toner darkness

- 1 From the home screen, touch **Settings > Print > Quality**.
- 2 Adjust the toner darkness.
- 3 Apply the changes.

## Job prints from the wrong tray or on the wrong paper

Action	Yes	No
<p><b>Step 1</b></p> <p><b>a</b> Check if you are printing on the correct paper.</p> <p><b>b</b> Print the document.</p> <p>Is the document printed on the correct paper?</p>	Go to step 2.	Load the correct paper size and paper type.
<p><b>Step 2</b></p> <p><b>a</b> Depending on your operating system, specify the paper size and paper type from the Printing Preferences or Print dialog.</p> <p><b>Note:</b> You can also change the settings on the printer control panel. From the home screen, touch <b>Settings &gt; Paper &gt; Tray Configuration &gt; Paper Size/Type</b>.</p> <p><b>b</b> Make sure that the settings match the paper loaded.</p> <p><b>c</b> Print the document.</p> <p>Is the document printed on the correct paper?</p>	The problem is solved.	Go to step 3.

Action	Yes	No
<p><b>Step 3</b></p> <p><b>a</b> Check if the trays are linked. For more information, see <a href="#">“Linking trays” on page 23</a>.</p> <p><b>b</b> Print the document.</p> <p>Is the document printed from the correct tray?</p>	<p>The problem is solved.</p>	<p>Contact your <a href="#">dealer</a>.</p>

## Faxing problems

### Cannot send or receive faxes

Action	Yes	No
<p><b>Step 1</b></p> <p>Resolve any error messages that appear on the display.</p> <p>Can you send or receive a fax?</p>	<p>The problem is solved.</p>	<p>Go to step 2.</p>
<p><b>Step 2</b></p> <p>Make sure that the cable connections for the following equipment are secure:</p> <ul style="list-style-type: none"> <li>• Telephone</li> <li>• Handset</li> <li>• Answering machine</li> </ul> <p>Can you send or receive a fax?</p>	<p>The problem is solved.</p>	<p>Go to step 3.</p>
<p><b>Step 3</b></p> <p>Check for a dial tone.</p> <ul style="list-style-type: none"> <li>• Call the fax number to check if it is working properly.</li> <li>• If you are using the On Hook Dial feature, then turn up the volume to check if you hear a dial tone.</li> </ul> <p>Can you hear a dial tone?</p>	<p>Go to step 5.</p>	<p>Go to step 4.</p>
<p><b>Step 4</b></p> <p>Check the telephone wall jack.</p> <ul style="list-style-type: none"> <li><b>a</b> Connect the analog telephone directly to the wall jack.</li> <li><b>b</b> Listen for a dial tone.</li> <li><b>c</b> If you do not hear a dial tone, then use a different telephone cable.</li> <li><b>d</b> If you still do not hear a dial tone, then connect the analog telephone to a different wall jack.</li> <li><b>e</b> If you hear a dial tone, then connect the printer to that wall jack.</li> </ul> <p>Can you send or receive a fax?</p>	<p>The problem is solved.</p>	<p>Go to step 5.</p>

Action	Yes	No
<p><b>Step 5</b></p> <p>Check if the printer is connected to an analog phone service or to the correct digital connector.</p> <ul style="list-style-type: none"> <li>• If you are using an Integrated Services for Digital Network (ISDN) telephone service, then connect to an analog telephone port of an ISDN terminal adapter. For more information, contact your ISDN provider.</li> <li>• If you are using DSL, then connect to a DSL filter or router that supports analog use. For more information, contact your DSL provider.</li> <li>• If you are using a private branch exchange (PBX) telephone service, then make sure that you are connecting to an analog connection on the PBX. If none exists, then consider installing an analog telephone line for the fax machine.</li> </ul> <p>Can you send or receive a fax?</p>	<p>The problem is solved.</p>	<p>Go to step 6.</p>
<p><b>Step 6</b></p> <p>Temporarily disconnect other equipment and disable other telephone services.</p> <ul style="list-style-type: none"> <li><b>a</b> Disconnect other equipment (such as answering machines, computers, modems, or telephone line splitters) between the printer and the telephone line.</li> <li><b>b</b> Disable call waiting and voice mail. For more information, contact your telephone company.</li> </ul> <p>Can you send or receive a fax?</p>	<p>The problem is solved.</p>	<p>Go to step 7.</p>
<p><b>Step 7</b></p> <p>Scan the original document one page at a time.</p> <ul style="list-style-type: none"> <li><b>a</b> Dial the fax number.</li> <li><b>b</b> Scan the document.</li> </ul> <p>Can you send or receive a fax?</p>	<p>The problem is solved.</p>	<p>Contact your <a href="#">dealer</a>.</p>

### Can receive but not send faxes

Action	Yes	No
<p><b>Step 1</b> Load the original document properly into the ADF tray or on the scanner glass.</p> <p>Can you send faxes?</p>	The problem is solved.	Go to step 2.
<p><b>Step 2</b> Set up the shortcut number properly.</p> <ul style="list-style-type: none"> <li>• Check if the shortcut number is set for the telephone number that you want to dial.</li> <li>• Dial the telephone number manually.</li> </ul> <p>Can you send faxes?</p>	The problem is solved.	Contact your <a href="#">dealer</a> .

### Can send but not receive faxes

Action	Yes	No
<p><b>Step 1</b> Make sure that the paper source is not empty.</p> <p>Can you receive faxes?</p>	The problem is solved.	Go to step 2.
<p><b>Step 2</b> Check the ring count delay settings. From the home screen, touch <b>Settings &gt; Fax &gt; Fax Setup &gt; Fax Receive Settings &gt; Rings to Answer</b>.</p> <p>Can you receive faxes?</p>	The problem is solved.	Go to step 3.
<p><b>Step 3</b> If the printer is printing blank pages, then see <a href="#">“Blank or white pages” on page 163</a>.</p> <p>Can you receive faxes?</p>	The problem is solved.	Contact your <a href="#">dealer</a> .

### Poor fax print quality

Action	Yes	No
<p><b>Step 1</b> Enhance the print quality.</p> <p><b>a</b> From the home screen, touch <b>Settings &gt; Print &gt; Quality</b>.</p> <p><b>b</b> Adjust the settings.</p> <p>Is the fax print quality satisfactory?</p>	The problem is solved.	Go to step 2.

Action	Yes	No
<p><b>Step 2</b>                      Decrease the incoming fax transmission speed.</p> <p><b>a</b> From the home screen, touch <b>Settings &gt; Fax &gt; Fax Setup &gt; Fax Receive Settings &gt; Admin Controls &gt; Max Speed.</b></p> <p><b>b</b> Select a lower transmission speed.</p> <p>Is the fax print quality satisfactory?</p>	<p>The problem is solved.</p>	<p>Go to step 3.</p>
<p><b>Step 3</b>                      Replace the toner cartridge.                      For more information, see the instruction sheet that came with the supply item.</p> <p>Is the fax print quality satisfactory?</p>	<p>The problem is solved.</p>	<p>Contact your <a href="#">dealer</a>.</p>

## Scanning problems

### Cannot scan from a computer

Action	Yes	No
<p><b>Step 1</b></p> <p><b>a</b> Turn off the printer, wait for about 10 seconds, and then turn it back on.</p> <p><b>b</b> Resend the scan job.</p> <p>Can you send the scan job?</p>	<p>The problem is solved.</p>	<p>Go to step 2.</p>
<p><b>Step 2</b></p> <p><b>a</b> Make sure that the cables between the printer and the print server are secure.                      For more information, see the setup documentation that came with the printer.</p> <p><b>b</b> Resend the scan job.</p> <p>Can you send the scan job?</p>	<p>The problem is solved.</p>	<p>Contact your <a href="#">dealer</a>.</p>

### Partial copies of document or photo

Action	Yes	No
<p><b>Step 1</b></p> <p><b>a</b> Make sure that the document or photo is loaded facedown on the upper left corner of the scanner glass.</p> <p><b>b</b> Copy the document or photo.</p> <p>Is the document or photo copied correctly?</p>	The problem is solved.	Go to step 2.
<p><b>Step 2</b></p> <p><b>a</b> Match the paper size setting and the paper loaded in the tray.</p> <p><b>b</b> Copy the document or photo.</p> <p>Is the document or photo copied correctly?</p>	The problem is solved.	Contact your <a href="#">dealer</a> .

### Poor copy quality

Action	Yes	No
<p><b>Step 1</b></p> <p><b>a</b> Clean the scanner glass and the ADF glass with a damp, soft, lint-free cloth. If your printer has a second ADF glass inside the ADF, then also clean that glass.</p> <p>For more information, see <a href="#">“Cleaning the scanner” on page 125</a>.</p> <p><b>b</b> Make sure that the document or photo is loaded facedown on the upper left corner of the scanner glass.</p> <p><b>c</b> Copy the document or photo.</p> <p>Is the copy quality satisfactory?</p>	The problem is solved.	Go to step 2.
<p><b>Step 2</b></p> <p><b>a</b> Check the quality of the original document or photo.</p> <p><b>b</b> Adjust the scan quality settings.</p> <p><b>c</b> Copy the document or photo.</p> <p>Is the copy quality satisfactory?</p>	The problem is solved.	Contact your <a href="#">dealer</a> .

### Vertical dark streaks on output when scanning from the ADF

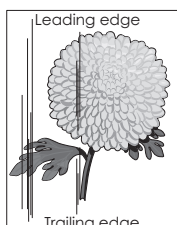
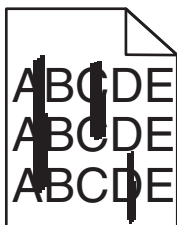



Action	Yes	No
<p><b>Step 1</b></p> <p><b>a</b> Open the scanner cover.</p> <p><b>b</b> Using a damp, soft, lint-free cloth, wipe the ADF glass and the white underside of the ADF cover.</p> <p><b>c</b> Close the scanner cover.</p> <p>Do vertical streaks still appear on scanned documents?</p>	Go to step 2.	The problem is solved.
<p><b>Step 2</b></p> <p><b>a</b> Open door C.</p> <p><b>b</b> Using a damp, soft, lint-free cloth, wipe the ADF glass and the white underside of the ADF cover.</p> <p><b>c</b> Close the door.</p> <p>Do vertical streaks still appear on scanned documents?</p>	Contact your <a href="#">dealer</a> .	The problem is solved.

### Scan job was not successful

Action	Yes	No
<p><b>Step 1</b></p> <p>Check the cable connections.</p> <p><b>a</b> Make sure that the Ethernet or USB cable is securely connected to the computer and the printer.</p> <p><b>b</b> Resend the scan job.</p> <p>Is the scan job successful?</p>	The problem is solved.	Go to step 2.
<p><b>Step 2</b></p> <p>Check the file that you want to scan.</p> <p><b>a</b> Make sure that the file name is not already used in the destination folder.</p> <p><b>b</b> Make sure that the document or photo you want to scan is not open in another application.</p> <p><b>c</b> Resend the scan job.</p> <p>Is the scan job successful?</p>	The problem is solved.	Go to step 3.
<p><b>Step 3</b></p> <p><b>a</b> Make sure that the Append time stamp or the Overwrite existing file check box is selected in the destination configuration settings.</p> <p><b>b</b> Resend the scan job.</p> <p>Is the scan job successful?</p>	The problem is solved.	

### Scanner does not close

Action	Yes	No
Remove obstructions that keep the scanner unit open.  Did the scanner unit close correctly?	The problem is solved.	Contact your <a href="#">dealer</a> .

### Scanning takes too long or freezes the computer

Action	Yes	No
Close all applications that are interfering with the scan.  Does scanning take too long or freeze the computer?	Contact your <a href="#">dealer</a> .	The problem is solved.

### Scanner does not respond

Action	Yes	No
<p><b>Step 1</b></p> <p><b>a</b> Check if the power cord is connected properly to the printer and the electrical outlet.</p> <p> <b>CAUTION—POTENTIAL INJURY:</b> To avoid the risk of fire or electrical shock, connect the power cord to an appropriately rated and properly grounded electrical outlet that is near the product and easily accessible.</p> <p><b>b</b> Copy or scan the document.</p> <p>Is the scanner responding?</p>	The problem is solved.	Go to step 2.
<p><b>Step 2</b></p> <p><b>a</b> Check if the printer is turned on.</p> <p><b>b</b> Resolve any error messages that appear on the display.</p> <p><b>c</b> Copy or scan the document.</p> <p>Is the scanner responding?</p>	The problem is solved.	Go to step 3.
<p><b>Step 3</b></p> <p><b>a</b> Turn off the printer, wait for about 10 seconds, and then turn the printer on.</p> <p><b>b</b> Copy or scan the document.</p> <p>Is the scanner responding?</p>	The problem is solved.	Contact your <a href="#">dealer</a> .

## Adjusting scanner registration

- 1 From the home screen, touch **Settings > Device > Maintenance > Configuration Menu > Scanner Configuration > Scanner Manual Registration**.
- 2 In the Print Quick Test menu, touch **Start**.
- 3 Place the Print Quick Test page on the scanner glass, and then touch **Flatbed Registration**.
- 4 In the Copy Quick Test menu, touch **Start**.
- 5 Compare the Copy Quick Test page with the original document.  
**Note:** If the margins of the test page are different from the original document, then adjust Left Margin and Top Margin.
- 6 Repeat [step 4](#) and [step 5](#) until the margins of the Copy Quick Test page closely match the original document.

## Adjusting ADF registration

- 1 From the home screen, touch **Settings > Device > Maintenance > Configuration Menu > Scanner Configuration > Scanner Manual Registration**.
- 2 In the Print Quick Test menu, touch **Start**.
- 3 Place the Print Quick Test page on the ADF tray.
- 4 Touch **Front ADF Registration** or **Rear ADF Registration**.  
**Notes:**
  - To align Front ADF Registration, place the test page faceup, short edge first into the ADF.
  - To align Rear ADF Registration, place the test page facedown, short edge first into the ADF.
- 5 In the Copy Quick Test menu, touch **Start**.
- 6 Compare the Copy Quick Test page with the original document.  
**Note:** If the margins of the test page are different from the original document, then adjust Horizontal Adjust and Top Margin.
- 7 Repeat [step 5](#) and [step 6](#) until the margins of the Copy Quick Test page closely match the original document.

## Contacting your dealer

Before contacting your dealer, make sure to have the following information:

- Printer problem
- Error message
- Printer model type and serial number

Visit the place where you purchased your printer.

# Upgrading and migrating

## Hardware

### Available internal options

- Flash memory
- Font cards
- Firmware cards
  - Bar Code
  - IPDS

### Accessing the controller board



**CAUTION—SHOCK HAZARD:** To avoid the risk of electrical shock, if you are accessing the controller board or installing optional hardware or memory devices sometime after setting up the printer, then turn the printer off, and unplug the power cord from the electrical outlet before continuing. If you have any other devices attached to the printer, then turn them off as well, and unplug any cables going into the printer.

- 1 Turn off the printer.
- 2 Unplug the power cord from the electrical outlet, and then from the printer.
- 3 Using a flat-head screwdriver, open the controller board access cover.

**Warning—Potential Damage:** Controller board electronic components are easily damaged by static electricity. Touch a metal surface on the printer before touching any controller board components or connectors.

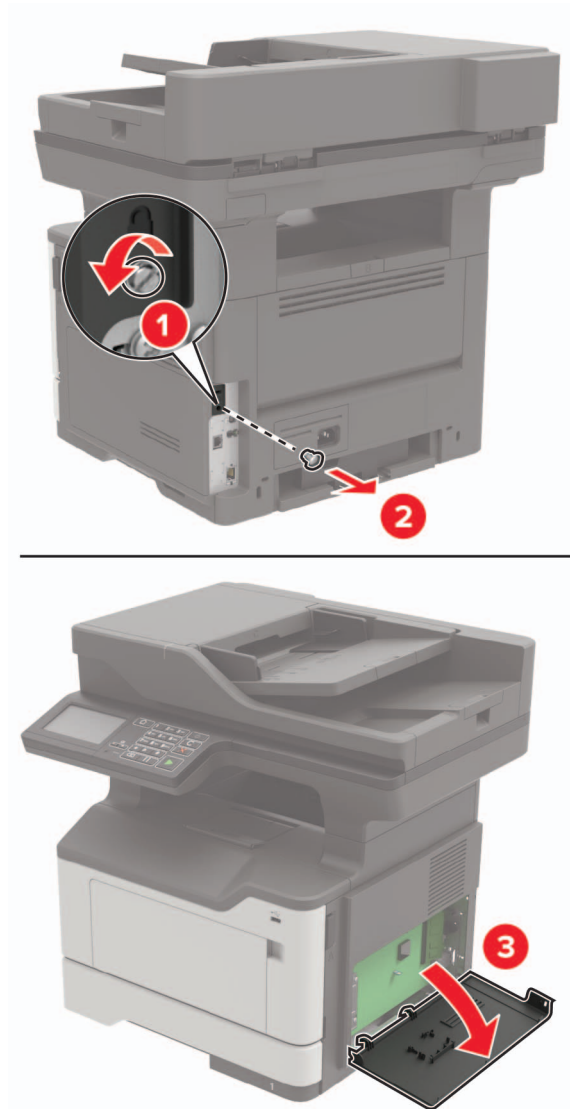

4 Close the access cover.

5 Connect the power cord to the printer, and then to the electrical outlet.

**⚠ CAUTION—POTENTIAL INJURY:** To avoid the risk of fire or electrical shock, connect the power cord to an appropriately rated and properly grounded electrical outlet that is near the product and easily accessible.

6 Turn on the printer.

## Installing an optional card

**⚠ CAUTION—SHOCK HAZARD:** To avoid the risk of electrical shock, if you are accessing the controller board or installing optional hardware or memory devices sometime after setting up the printer, then turn the printer off, and unplug the power cord from the electrical outlet before continuing. If you have any other devices attached to the printer, then turn them off as well, and unplug any cables going into the printer.

- 1 Turn off the printer.
- 2 Unplug the power cord from the electrical outlet, and then from the printer.
- 3 Open the controller board access cover.

**Warning—Potential Damage:** Controller board electronic components are easily damaged by static electricity. Touch a metal surface on the printer before touching any components or connectors.

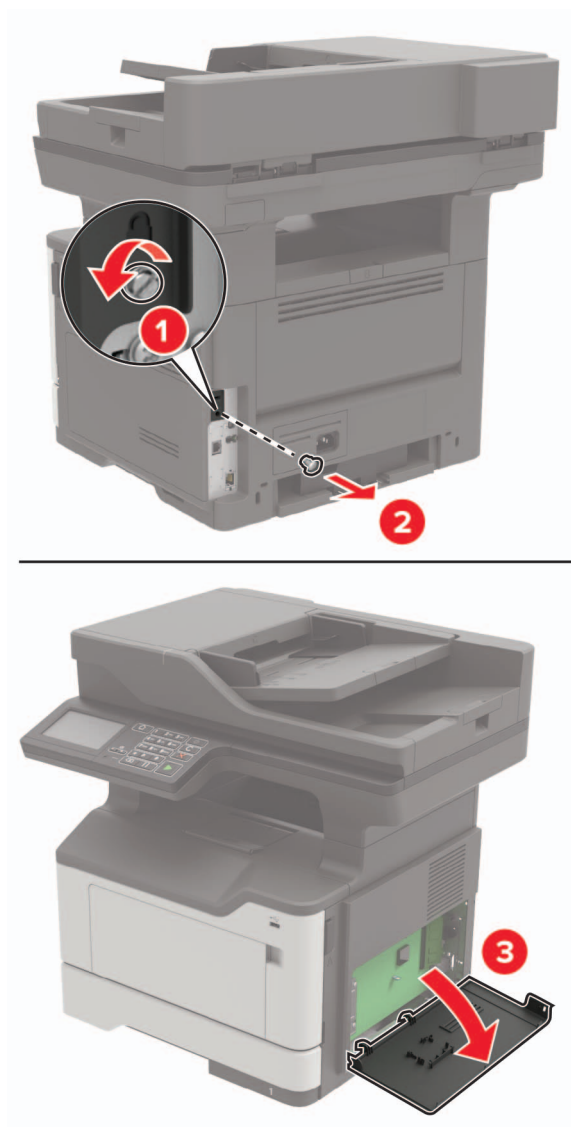

- 4 Unpack the optional card.

**Warning—Potential Damage:** Do not touch the connection points along the edge of the card.

- 5 Push the card firmly into place.

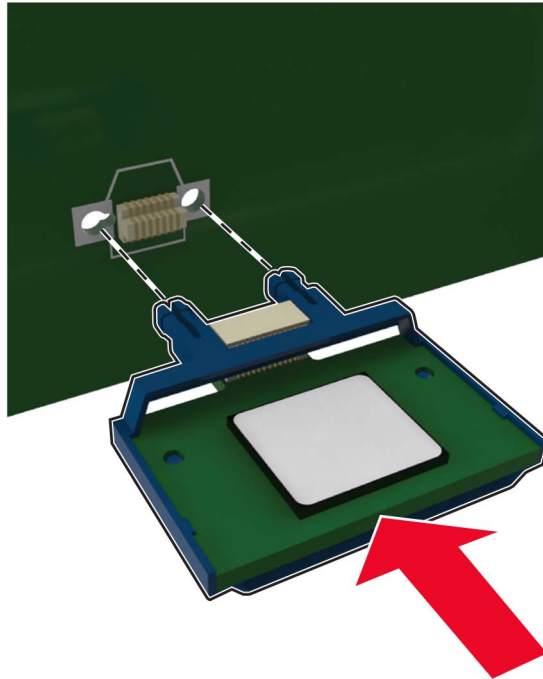

**Note:** The entire length of the connector on the card must touch and be flush against the controller board.

**Warning—Potential Damage:** Improper installation of the card may cause damage to the card and the controller board.

- 6 Close the access cover.
- 7 Connect the power cord to the printer, and then to the electrical outlet.

**CAUTION—POTENTIAL INJURY:** To avoid the risk of fire or electrical shock, connect the power cord to an appropriately rated and properly grounded electrical outlet that is near the product and easily accessible.

- 8 Turn on the printer.

## Installing a printer hard disk

**CAUTION—SHOCK HAZARD:** To avoid the risk of electrical shock, if you are accessing the controller board or installing optional hardware or memory devices sometime after setting up the printer, then turn the printer off, and unplug the power cord from the electrical outlet before continuing. If you have any other devices attached to the printer, then turn them off as well, and unplug any cables going into the printer.

- 1 Turn off the printer.
- 2 Unplug the power cord from the electrical outlet, and then from the printer.
- 3 Open the controller board access cover.

**Warning—Potential Damage:** Controller board electronic components are easily damaged by static electricity. Touch a metal surface on the printer before touching any controller board components or connectors.

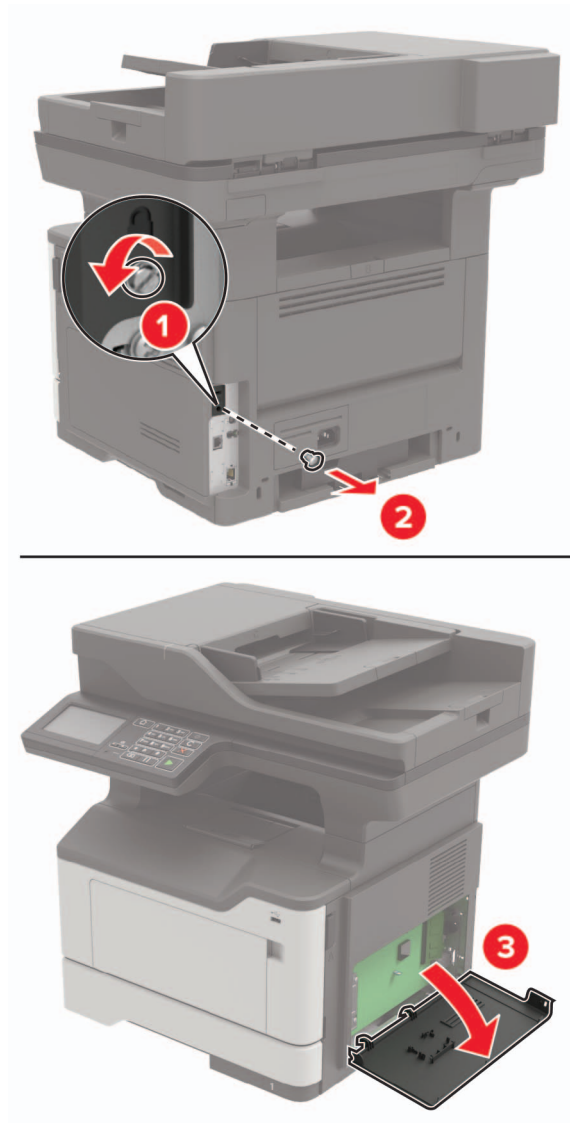

**4** Unpack the hard disk.

**5** Attach the hard disk to the controller board.

**Warning—Potential Damage:** Do not touch or press the center of the hard disk.



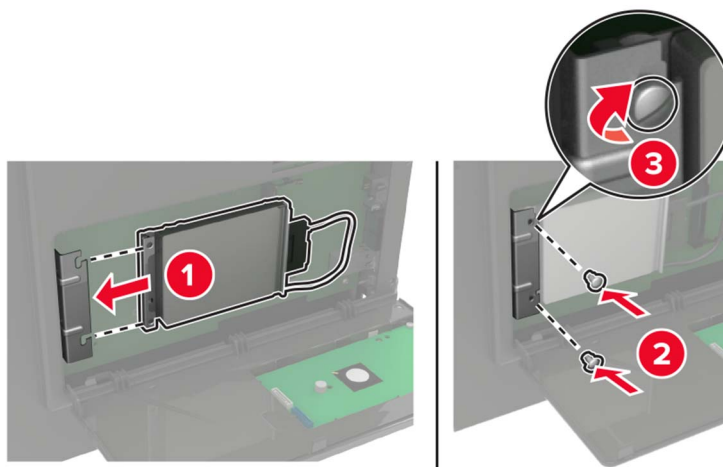

- 6 Attach the hard disk interface cable to the controller board.

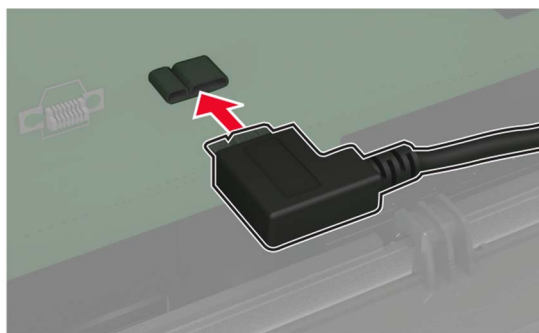

- 7 Close the access cover.  
8 Connect the power cord to the printer, and then to the electrical outlet.

**⚠ CAUTION—POTENTIAL INJURY:** To avoid the risk of fire or electrical shock, connect the power cord to an appropriately rated and properly grounded electrical outlet that is near the product and easily accessible.

- 9 Turn on the printer.

## Installing an internal solutions port

**⚠ CAUTION—SHOCK HAZARD:** To avoid the risk of electrical shock, if you are accessing the controller board or installing optional hardware or memory devices sometime after setting up the printer, then turn the printer off, and unplug the power cord from the electrical outlet before continuing. If you have any other devices attached to the printer, then turn them off as well, and unplug any cables going into the printer.

- 1 Turn off the printer.
- 2 Unplug the power cord from the electrical outlet, and then from the printer.
- 3 Unpack the internal solutions port (ISP) kit.

**Note:** Remove the preinstalled interface cable from the ISP.

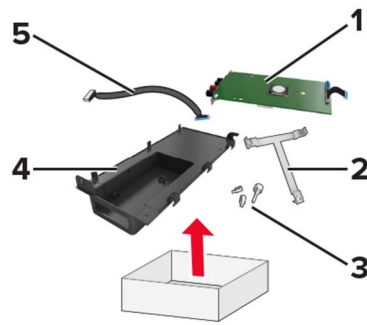

1	ISP
2	Mounting bracket
3	Thumbscrews
4	Housing
5	Interface cable

4 Install the ISP into its housing.

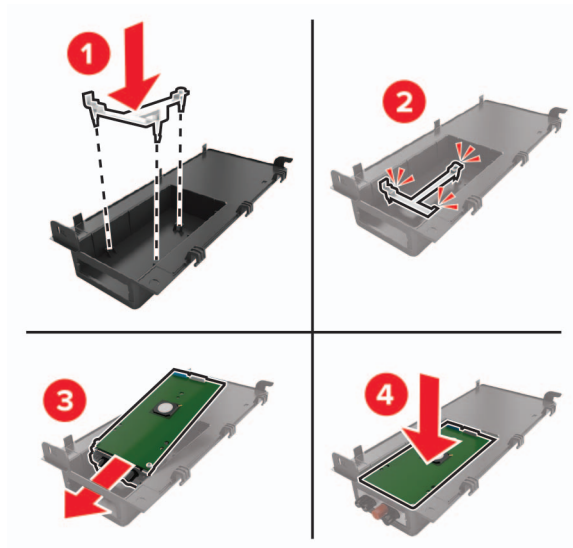

5 Secure the ISP in place and attach the ISP extended cable.

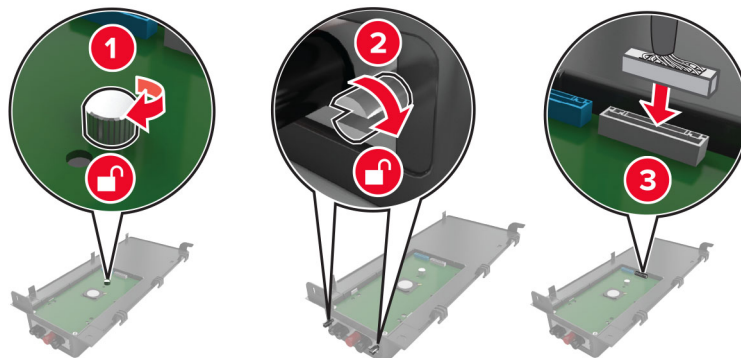

**6** Open, and then remove the controller board access cover.

**Warning—Potential Damage:** Controller board electronic components are easily damaged by static electricity. Touch a metal surface on the printer before touching any controller board electronic components or connectors.

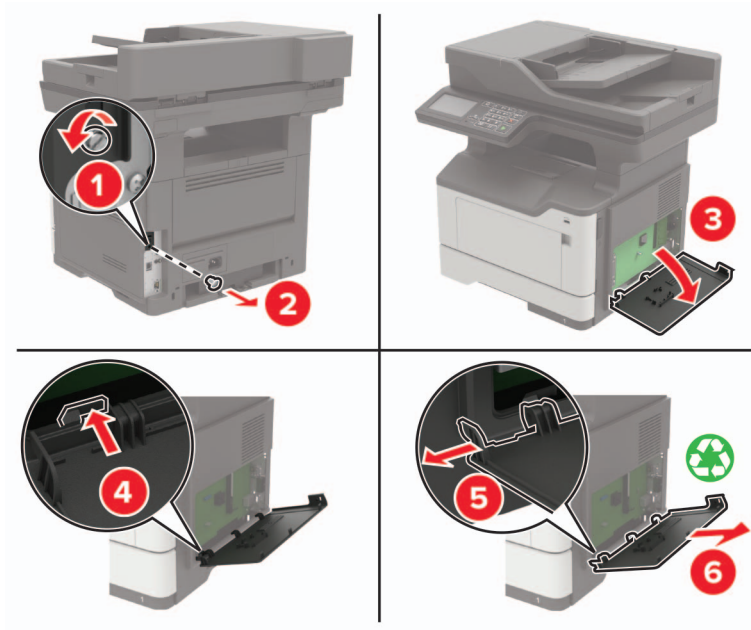

**7** Attach the ISP kit to the printer.

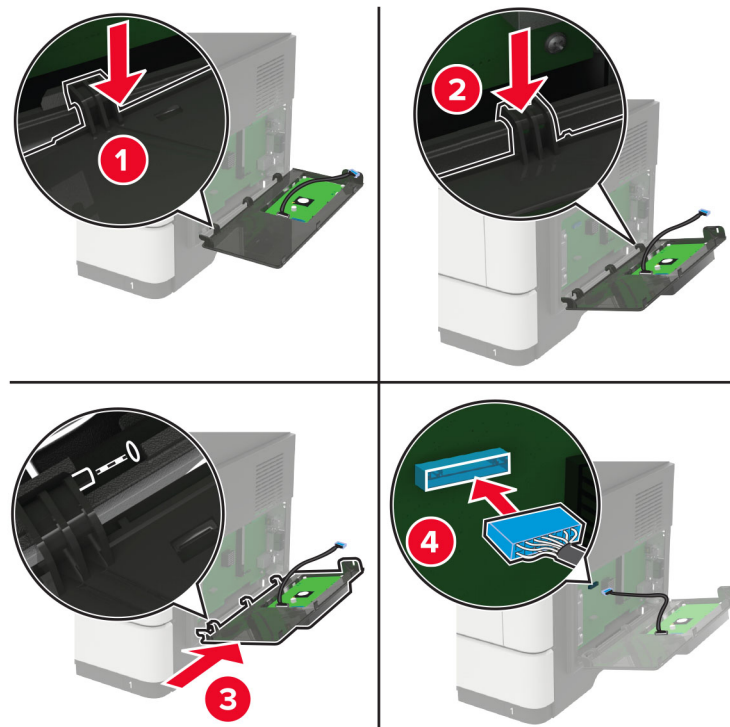

If a printer hard disk is installed, then remove the hard disk before installing the ISP.

- a** Unplug the hard disk interface cable from the controller board.

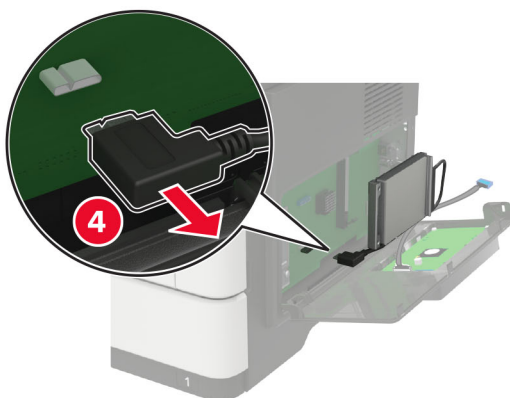
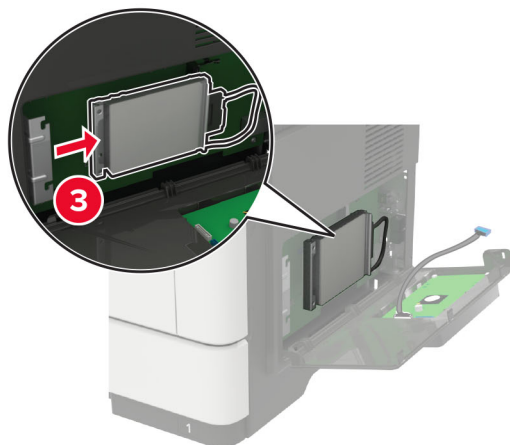
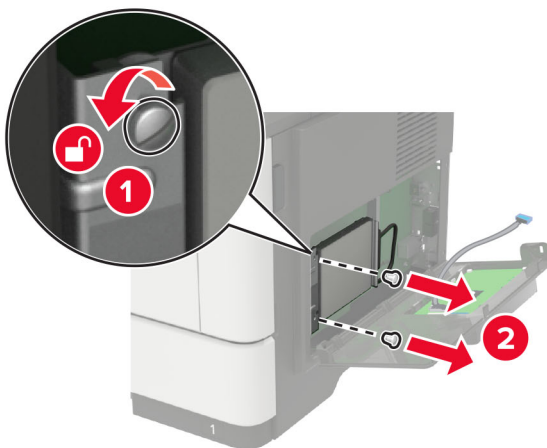

- b** Connect the ISP extended cable to the ISP connector.

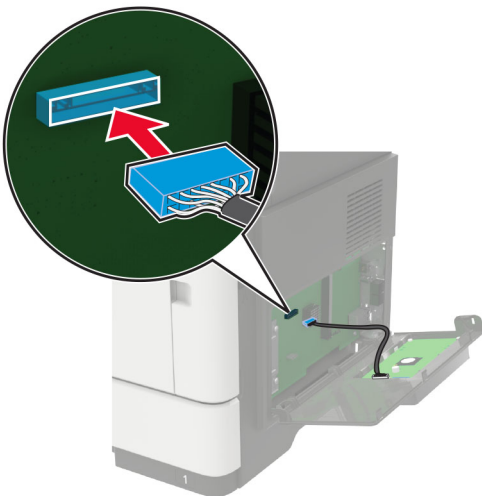

c Install the hard disk.



- 8 Close the access cover.
- 9 Connect the power cord to the printer, and then to the electrical outlet.

**⚠ CAUTION—POTENTIAL INJURY:** To avoid the risk of fire or electrical shock, connect the power cord to an appropriately rated and properly grounded electrical outlet that is near the product and easily accessible.

- 10 Turn on the printer.

## Installing optional trays

**⚠ CAUTION—SHOCK HAZARD:** To avoid the risk of electrical shock, if you are accessing the controller board or installing optional hardware or memory devices sometime after setting up the printer, then turn the printer off, and unplug the power cord from the electrical outlet before continuing. If you have any other devices attached to the printer, then turn them off as well, and unplug any cables going into the printer.

- 1 Turn off the printer.
- 2 Unplug the power cord from the electrical outlet, and then from the printer.
- 3 Unpack the optional tray, and then remove all packing material.

**Note:** If optional trays are already installed, then unlock them from the printer before lifting the printer. Do not try to lift the printer and trays at the same time.

- 4 Align the printer with the optional tray, and then lower the printer until it *clicks* into place.

**⚠ CAUTION—POTENTIAL INJURY:** If the printer weight is greater than 20 kg (44 lb), then it may require two or more people to lift it safely.



- 5 Connect the power cord to the printer, and then to the electrical outlet.

**⚠ CAUTION—POTENTIAL INJURY:** To avoid the risk of fire or electrical shock, connect the power cord to an appropriately rated and properly grounded electrical outlet that is near the product and easily accessible.

- 6 Turn on the printer.

Add the tray in the print driver to make it available for print jobs. For more information, see [“Adding available options in the print driver” on page 201](#).

## Software

### Supported operating systems

Using the software CD, you can install the printer software on the following operating systems:

- Windows 10
- Windows 8.1
- Windows Server 2012 R2
- Windows Server 2012
- Windows 7 SP1
- Windows Server 2008 R2 SP1
- Windows Server 2008 SP2
- Windows Vista SP2
- Mac OS X version 10.7 or later
- Red Hat Enterprise Linux WS
- openSUSE Linux
- SUSE Linux Enterprise Server
- Debian GNU/Linux
- Ubuntu
- Fedora
- IBM AIX
- Oracle Solaris SPARC
- Oracle Solaris x86

#### Notes:

- For Windows operating systems, the print drivers and utilities are supported in both 32- and 64-bit versions.
- For drivers and utilities that are compatible with Mac OS X version 10.6 or earlier and for specific supported Linux or UNIX operating system versions, go to our website.
- For more information on software compatibility with all other operating systems, contact customer support.

### Installing the printer software

- 1 Obtain a copy of the software installer package.
  - From our website.
  - From the place where you purchased the printer.
- 2 Run the installer, and then follow the instructions.



- 3 For Macintosh users, add the printer.

**Note:** For Macintosh computers with macOS version 10.7 or later, you do not need to install the driver to print on an AirPrint-certified printer.

## Adding available options in the print driver

### For Windows users

- 1 Open the printers folder.
- 2 Select the printer you want to update, and then do either of the following:
  - For Windows 7 or later, select **Printer properties**.
  - For earlier versions, select **Properties**.
- 3 Navigate to the Configuration tab, and then select **Update Now - Ask Printer**.
- 4 Apply the changes.

### For Macintosh users

- 1 From System Preferences in the Apple menu, navigate to your printer, and then select **Options & Supplies**.
- 2 Navigate to the list of hardware options, and then add any installed options.
- 3 Apply the changes.

## Firmware

### Exporting or importing a configuration file

You can export the configuration settings of your printer into a text file, and then import the file to apply the settings to other printers.

- 1 Open a web browser, and then type the printer IP address in the address field.

**Notes:**

- View the printer IP address on the printer home screen. The IP address appears as four sets of numbers separated by periods, such as 123.123.123.123.
- If you are using a proxy server, then temporarily disable it to load the web page correctly.

- 2 Export or import a configuration file for one or multiple applications.

#### For one application

- a From the Embedded Web Server, click **Apps** > the application that you want > **Configure**.
- b Click **Export** or **Import**.

#### For multiple applications

- a From the Embedded Web Server, click **Export Configuration** or **Import Configuration**.
- b Follow the instructions on the screen.

## Updating firmware

Some applications require a minimum device firmware level to operate correctly.

For more information on updating the device firmware, contact your sales representative.

- 1** From the Embedded Web Server, click **Settings > Device > Update Firmware**.
- 2** Browse to locate the required flash file.
- 3** Apply the changes.

# Notices

## Product information

Product name:

DIGITAL MULTIFUNCTIONAL SYSTEM MX-B467F

Machine type:

7017

Model(s):

679 and its equivalent models

## Edition notice

November 2020

**The following paragraph does not apply to any country where such provisions are inconsistent with local law:** THIS PUBLICATION IS PROVIDED "AS IS" WITHOUT WARRANTY OF ANY KIND, EITHER EXPRESS OR IMPLIED, INCLUDING, BUT NOT LIMITED TO, THE IMPLIED WARRANTIES OF MERCHANTABILITY OR FITNESS FOR A PARTICULAR PURPOSE. Some states do not allow disclaimer of express or implied warranties in certain transactions; therefore, this statement may not apply to you.

This publication could include technical inaccuracies or typographical errors. Changes are periodically made to the information herein; these changes will be incorporated in later editions. Improvements or changes in the products or the programs described may be made at any time.

## GOVERNMENT END USERS

The Software Program and any related documentation are "Commercial Items," as that term is defined in 48 C.F.R. 2.101, "Computer Software" and "Commercial Computer Software Documentation," as such terms are used in 48 C.F.R. 12.212 or 48 C.F.R. 227.7202, as applicable. Consistent with 48 C.F.R. 12.212 or 48 C.F.R. 227.7202-1 through 227.7207-4, as applicable, the Commercial Computer Software and Commercial Software Documentation are licensed to the U.S. Government end users (a) only as Commercial Items and (b) with only those rights as are granted to all other end users pursuant to the terms and conditions herein.

## Supplies

Standard supplies for this product that can be replaced by the user include toner cartridges.

Be sure to use only SHARP-specified products for the toner cartridges.

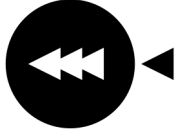
 <p><b>SHARP</b> GENUINE SUPPLIES</p>	<p>For best copying results, be sure to use only Sharp Genuine Supplies which are designed, engineered, and tested to maximize the life and performance of Sharp products. Look for the Genuine Supplies label on the toner package.</p>
--	--

### Noise emission levels

The following measurements were made in accordance with ISO 7779 and reported in conformance with ISO 9296.

**Note:** Some modes may not apply to your product.

1-meter average sound pressure, dBA	
Printing	One-sided: 56 Two-sided: 55
Scanning	51
Copying	57
Ready	14

### Waste from Electrical and Electronic Equipment (WEEE) directive



The WEEE logo signifies specific recycling programs and procedures for electronic products in countries of the European Union. We encourage the recycling of our products. If you have further questions about recycling options, contact your local sales office.

### India E-Waste notice



This product complies with the India E-Waste (Management and Handling) Rules, 2011, which prohibit use of lead, mercury, hexavalent chromium, polybrominated biphenyls, or polybrominated diphenyl ethers in concentrations exceeding 0.1% by weight and 0.01% by weight for cadmium, except for the exemption set in Schedule II of the Rules.

## Product disposal

Do not dispose of the printer or supplies in the same manner as normal household waste. Consult your local authorities for disposal and recycling options.

## Static sensitivity notice

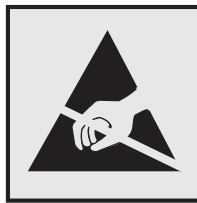

This symbol identifies static-sensitive parts. Do not touch the areas near these symbols without first touching a metal surface in an area away from the symbol.

## ENERGY STAR

Any product bearing the ENERGY STAR® emblem on the product or on a start-up screen is certified to comply with Environmental Protection Agency (EPA) ENERGY STAR requirements as of the date of manufacture.



## Temperature information

Ambient operating temperature	10 to 32°C (50 to 90°F)
Shipping temperature	-20 to 40°C (-4 to 104°F)
Storage temperature and relative humidity	0 to 40°C (32 to 104°F) 8 to 80% RH

## Laser notice

The printer is certified in the U.S. to conform to the requirements of DHHS 21 CFR, Chapter I, Subchapter J for Class I (1) laser products, and elsewhere is certified as a Class I laser product conforming to the requirements of IEC 60825-1: 2014.

Class I laser products are not considered to be hazardous. The laser system and printer are designed so there is never any human access to laser radiation above a Class I level during normal operation, user maintenance, or prescribed service conditions. The printer has a non-serviceable printhead assembly that contains a laser with the following specifications:

Class: IIIb (3b) AlGaInP

Nominal output power (milliwatts): 15

Wavelength (nanometers): 650–670

## Power consumption

### Product power consumption

The following table documents the power consumption characteristics of the product.

**Note:** Some modes may not apply to your product.

Mode	Description	Power consumption (Watts)
Printing	The product is generating hard-copy output from electronic inputs.	One-sided: 620 Two-sided: 385
Copy	The product is generating hard-copy output from hard-copy original documents.	630
Scan	The product is scanning hard-copy documents.	20
Ready	The product is waiting for a print job.	14.5
Sleep Mode	The product is in a high-level energy-saving mode.	1.41
Hibernate	The product is in a low-level energy-saving mode.	0.1
Off	The product is plugged into an electrical outlet, but the power switch is turned off.	0.1

The power consumption levels listed in the previous table represent time-averaged measurements. Instantaneous power draws may be substantially higher than the average.

### Sleep Mode

This product is designed with an energy-saving mode called *Sleep Mode*. The Sleep Mode saves energy by lowering power consumption during extended periods of inactivity. The Sleep Mode is automatically engaged after this product is not used for a specified period of time, called the *Sleep Mode Timeout*.

Factory default Sleep Mode Timeout for this product (in minutes):	15
---	----

By using the configuration menus, the Sleep Mode Timeout can be modified between 1 minute and 120 minutes. If the print speed is less than or equal to 30 pages per minute, then you can set the timeout only up to 60 minutes. Setting the Sleep Mode Timeout to a low value reduces energy consumption, but may increase the response time of the product. Setting the Sleep Mode Timeout to a high value maintains a fast response, but uses more energy.

## Hibernate Mode

This product is designed with an ultra-low power operating mode called *Hibernate mode*. When operating in Hibernate Mode, all other systems and devices are powered down safely.

The Hibernate mode can be entered in any of the following methods:

- Using the Hibernate Timeout
- Using the Schedule Power modes

Factory default Hibernate Timeout for this product in all countries or regions	3 days
--	--------

The amount of time the printer waits after a job is printed before it enters Hibernate mode can be modified between one hour and one month.

## Off mode

If this product has an off mode which still consumes a small amount of power, then to completely stop product power consumption, disconnect the power supply cord from the electrical outlet.

## Total energy usage

It is sometimes helpful to estimate the total product energy usage. Since power consumption claims are provided in power units of Watts, the power consumption should be multiplied by the time the product spends in each mode in order to calculate energy usage. The total product energy usage is the sum of each mode's energy usage.

## Environmental information

**Please read this part carefully. It will help you to reduce your impact on the environment and help you to reduce your costs at the same time.**

### Saving paper

- 1 The automated duplex printing function is for printing both sides of paper automatically without turning over the paper manually. If the machine is equipped with the automated duplex printing function, set up your print settings on your computer to automatically print double-sided. Please use the automatic duplex printing function of this machine wherever possible.
- 2 By printing on recycled paper and thin 64 g/m<sup>2</sup> paper that meet the standard EN12281:2002 and similar quality standards, you can reduce the impact on the environment.

### Saving energy

The ENERGY STAR® program is a voluntary scheme to promote the development and purchase of energy efficient models, which help to minimize environmental impact. Products which meet the stringent requirements of the ENERGY STAR program for both environmental benefits and the amount of energy consumption may carry the ENERGY STAR logo in case they have been registered with an ENERGY STAR program.

## Regulatory notices for telecommunication terminal equipment

This section contains regulatory information pertaining to products that contain the analog facsimile card:

Regulatory Type/Model Number:

LEX-M14-002

## **Notice to users of the US telephone network: FCC requirements**

This equipment complies with Part 68 of the FCC rules and the requirements adopted by the Administrative Council for Terminal Attachments (ACTA). On the back of this equipment is a label that contains, among other information, a product identifier in the format US:AAAEQ##TXXXX. If requested, this number must be provided to your telephone company.

This equipment uses the RJ-11C Universal Service Order Code (USOC) jack.

A plug and jack used to connect this equipment to the premises' wiring and telephone network must comply with the applicable FCC Part 68 rules and requirements adopted by the ACTA. Use a compliant telephone cord (RJ-11) that is 26 AWG or larger when connecting this product to the public switched telephone network. See your setup documentation for more information.

The Ringer Equivalence Number (REN) is used to determine the number of devices that may be connected to a telephone line. Excessive RENs on a telephone line may result in the devices not ringing in response to an incoming call. In most but not all areas, the sum of RENs should not exceed five (5.0). To be certain of the number of devices that may be connected to a line, as determined by the total RENs, contact your local telephone company. For products approved after July 23, 2001, the REN for this product is part of the product identifier that has the format US:AAAEQ##TXXXX. The digits represented by ## are the REN without a decimal point (for example, 03 is a REN of 0.3). For earlier products, the REN is shown separately on the label.

If this equipment causes harm to the telephone network, the telephone company will notify you in advance that temporary discontinuance of service may be required. If advance notice is not practical, the telephone company will notify the customer as soon as possible. You will also be advised of your right to file a complaint with the FCC.

The telephone company may make changes in its facilities, equipment, operations or procedures that could affect the operation of this equipment. If this happens, the telephone company will provide advance notice in order for you to make necessary modifications to maintain uninterrupted service.

If you experience trouble with this equipment, for repair or warranty information, contact your point of purchase. If the equipment is causing harm to the telephone network, the telephone company may request that you disconnect the equipment until the problem is resolved.

This equipment contains no user serviceable parts. For repair and warranty information, contact your point of purchase.

Connection to party line service is subject to state tariffs. Contact the state public utility commission, public service commission, or corporation commission for information.

If your home has specially wired alarm equipment connected to the telephone line, ensure the installation of this equipment does not disable your alarm equipment. If you have questions about what will disable alarm equipment, consult your telephone company or a qualified installer.

The Telephone Consumer Protection Act of 1991 makes it unlawful for any person to use a computer or other electronic device, including fax machines, to send any message unless said message clearly contains in a margin at the top or bottom of each transmitted page or on the first page of the transmission, the date and time it is sent and an identification of the business or other entity, or other individual sending the message, and the telephone number of the sending machine or such business, other entity, or individual. (The telephone number provided may not be a 900 number or any other number for which charges exceed local or long-distance transmission charges.)



See your user documentation in order to program this information into your fax machine.

## **Notice to users of the Canadian telephone network**

This product meets the applicable Industry Canada technical specifications.

The Ringer Equivalence Number (REN) indicates the maximum number of devices allowed to be connected to a telephone interface. The termination of an interface may consist of any combination of devices subject only to the requirement that the sum of the RENs of all the devices not exceed five. The REN is located on the product label.

This equipment uses CA11A telephone jacks.

### **Avis réservé aux utilisateurs du réseau téléphonique du Canada**

Ce produit est conforme aux spécifications techniques d'Industrie Canada.

Le numéro REN (ringer equivalence number : numéro d'équivalence de sonnerie) indique le nombre maximum d'appareils pouvant être connectés à l'interface téléphonique. En bout de ligne, le nombre d'appareils qui peuvent être connectés n'est pas directement limité, mais la somme des REN de ces appareils ne doit pas dépasser cinq. Le numéro REN est indiqué sur l'étiquette produit.

Cet équipement utilise des prises de téléphone CA11A.

## **Notice to users of the New Zealand telephone network**

The following are special conditions for the Facsimile User Instructions. The grant of a telepermit for any item of terminal equipment indicates only that Telecom has accepted that the item complies with minimum conditions for connection to its network. It indicates no endorsement of the product by Telecom, nor does it provide any sort of warranty. Above all, it provides no assurance that any item will work correctly in all respects with another item of telepermitted equipment of a different make or model, nor does it imply that any product is compatible with all of Telecom's network services.

This equipment shall not be set up to make automatic calls to the Telecom "111" Emergency Service.

This equipment may not provide for the effective hand-over of a call to another device connected to the same line.

This equipment should not be used under any circumstances that may constitute a nuisance to other Telecom customers.

This equipment is not capable, under all operating conditions, of correct operation at the higher speeds for which it is designed. Telecom will accept no responsibility should difficulties arise in such circumstances.

The decadic (or pulse) dialing on this device is unsuitable for use on the Telecom network in New Zealand.

For correct operation, the total of all the Ringer Equivalence Numbers (RENs) of all parallel devices connected to the same telephone line may not exceed 5. The REN of this device is located on the label.

This device uses an RJ-11C modular connector. Contact your point of purchase if a BT adapter is required. The part number is 80D1873.

Some parameters required for compliance with Telecom's telepermit requirements are dependent on the equipment associated with this device. The associated equipment shall be set to operate within the following limits for compliance to Telecom's specifications:

- There shall be no more than 10 call attempts to the same number within any 30 minute period for any single manual call initiation, and
- The equipment shall go on-hook for a period of not less than 30 seconds between the end of one attempt and the beginning of the next call attempt.
- The equipment shall be set to ensure that automatic calls to different numbers are spaced such that there is not less than 5 seconds between the end of one call attempt and the beginning of another.

### Japanese telecom notice

The installed optional modem is in compliance with Japanese Telecommunication Law and has been Certified by JATE, with the following Certification Number:

A11-0160001JP

	Lexmark International, Inc.
	LEX-M14-002
	A11-0160001JP

### Using this product in Switzerland

This product requires a Swiss billing tone filter to be installed on any line which receives metering pulses in Switzerland.

### Utilisation de ce produit en Suisse

Cet appareil nécessite l'utilisation d'un filtre de tonalité de facturation suisse devant être installé sur toute ligne recevant des impulsions de comptage en Suisse.

### Verwendung dieses Produkts in der Schweiz

Für dieses Produkt muss ein schweizerischer Billing Tone Filter zur Zählzeichenübertragung für jede Leitung installiert werden, über die in der Schweiz Zeitsteuertakte übertragen werden.

### Uso del prodotto in Svizzera

Questo prodotto richiede un filtro toni Billing svizzero, a installare su tutte le linee che ricevono impulsi remoti in Svizzera.

## Regulatory notices for wireless products

This section contains regulatory information that applies only to wireless models.

If in doubt as to whether your model is a wireless model, go to our website.

### Modular component notice

Wireless models contain one of the following modular components:

Regulatory Type/Model Number LEX-M07-001; FCC ID:IYLLEXM07001; IC:2376A-LEXM07001

Regulatory Type/Model Number LEX-M08-001; FCC ID:IYLLEXM08001; IC:2376A-LEXM08001

To determine which modular components are installed in your particular product, refer to the labeling on your actual product.

### Exposure to radio frequency radiation

The radiated output power of this device is far below the radio frequency exposure limits of the FCC and other regulatory agencies. A minimum separation of 20 cm (8 inches) must be maintained between the antenna and any persons for this device to satisfy the RF exposure requirements of the FCC and other regulatory agencies.

### Industry Canada (Canada)

This device complies with Industry Canada license-exempt RSS standards. Operation is subject to the following two conditions: (1) this device may not cause interference, and (2) this device must accept any interference, including interference that may cause undesired operation of the device.

### Industrie Canada (Canada)

Cet appareil est conforme aux normes RSS exemptes de licence d'Industrie Canada. Son fonctionnement est soumis aux deux conditions suivantes : (1) cet appareil ne doit pas causer d'interférences et (2) il doit accepter toutes les interférences, y compris les celles qui peuvent entraîner un fonctionnement indésirable.

### European Community (EC) directives conformity

This product is in conformity with the protection requirements of EC Council directive 2014/53/EU on the approximation and harmonization of the laws of the Member States relating to radio equipment.

A declaration of conformity to the requirements of the Directives may be obtained at [www.lexmark.com/en\\_us/about/regulatory-compliance/european-union-declaration-of-conformity.html](http://www.lexmark.com/en_us/about/regulatory-compliance/european-union-declaration-of-conformity.html).

Compliance is indicated by the CE marking:



**Restrictions**

This radio equipment is restricted to indoor use only. Outdoor use is prohibited. This restriction applies to all the countries listed in the table below:

								
AT	BE	BG	CH	CY	CZ	DE	DK	EE
EL	ES	FI	FR	HR	HU	IE	IS	IT
LI	LT	LU	LV	MT	NL	NO	PL	PT
RO	SE	SI	SK	TR	UK			

**EU and other countries statement of radio transmitter operational frequency bands and maximum RF power**

This radio product transmits in either the 2.4GHz (2.412–2.472 GHz in the EU) or 5GHz (5.15–5.35, 5.47–5.725 in the EU) bands. The maximum transmitter EIRP power output, including antenna gain, is ≤ 20dBm for both bands.

**Federal Communications Commission (FCC) compliance information statement**

This product has been tested and found to comply with the limits for a Class A digital device, pursuant to Part 15 of the FCC Rules. Operation is subject to the following two conditions: (1) this device may not cause harmful interference, and (2) this device must accept any interference received, including interference that may cause undesired operation.

The FCC Class A limits are designed to provide reasonable protection against harmful interference when the equipment is operated in a commercial environment. This equipment generates, uses, and can radiate radio frequency energy and, if not installed and used in accordance with the instruction manual, may cause harmful interference to radio communications. Operation of this equipment in a residential area is likely to cause harmful interference, in which case the user will be required to correct the interference at his own expense.

The manufacturer is not responsible for any radio or television interference caused by using other than recommended cables or by unauthorized changes or modifications to this equipment. Unauthorized changes or modifications could void the user's authority to operate this equipment.

**Note:** To assure compliance with FCC regulations on electromagnetic interference for a Class A computing device, use a properly shielded and grounded cable such as Lexmark part number 1021231 for parallel attach or 1021294 for USB attach. Use of a substitute cable not properly shielded and grounded may result in a violation of FCC regulations.

Any questions regarding this compliance information statement should be directed to:

Director of Lexmark Technology & Services  
Lexmark International, Inc.  
740 West New Circle Road  
Lexington, KY 40550  
Telephone: (859) 232-2000  
E-mail: [regulatory@lexmark.com](mailto:regulatory@lexmark.com)

## Industry Canada compliance statement

This Class A digital apparatus meets all requirements of the Canadian Interference-Causing Equipment Standard ICES-003.

## Avis de conformité aux normes de l'industrie du Canada

Cet appareil numérique de classe A est conforme aux exigences de la norme canadienne relative aux équipements pouvant causer des interférences NMB-003.

## Notice to users of Class A products in Brazil

Este produto não é apropriado para uso em ambientes domésticos, pois poderá causar interferências eletromagnéticas que obrigam o usuário a tomar medidas necessárias para minimizar estas interferências.

## European Community (EC) directives conformity

This product is in conformity with the protection requirements of EC Council directives 2014/30/EU, 2014/35/EU, and 2011/65/EU as amended by (EU) 2015/863 on the approximation and harmonization of the laws of the Member States relating to electromagnetic compatibility, safety of electrical equipment designed for use within certain voltage limits, and on the restrictions of use of certain hazardous substances in electrical and electronic equipment.

A declaration of conformity to the requirements of the Directives may be obtained at [www.lexmark.com/en\\_us/about/regulatory-compliance/european-union-declaration-of-conformity.html](http://www.lexmark.com/en_us/about/regulatory-compliance/european-union-declaration-of-conformity.html).

This product satisfies the Class A limits of EN 55022 and EN55032 and safety requirements of EN 60950-1 or EN 62368-1.

## Radio interference notice

### Warning

This is a product that complies with the emission requirements of EN55022 and EN55032 Class A limits and immunity requirements of EN55024. This product is not intended to be used in residential/domestic environments.

This is a Class A product. In a domestic environment, this product may cause radio interference, in which case the user may be required to take adequate measures.

# Index

## A

- accessing the controller board 188
- adapter plug 40
- adding contacts 18
- adding groups 18
- adding hardware options
  - print driver 201
- adding internal options
  - print driver 201
- adding shortcut
  - fax destination 44
  - FTP address 46
- ADF registration
  - adjusting 187
- adjusting
  - scanner registration 187
- adjusting ADF registration 187
- adjusting the brightness
  - printer display 140
- adjusting the brightness of the printer display 140
- adjusting the default speaker volume 122
- adjusting toner darkness 179
- AirPrint
  - using 28
- Android device
  - printing from 28
- answering machine
  - setting up 38
- assigning printer to a ring pattern 43
- attaching cables 11
- avoiding paper jams 142

## B

- blocking junk faxes 45

## C

- can send but not receive faxes 182
- canceling a print job
  - from the computer 32
  - from the printer control panel 32

- cannot open Embedded Web Server 154
- cannot scan from a computer 183
- cannot send faxes 182
- cannot send or receive faxes 180
- Card Copy
  - setting up 16
- changing the wallpaper 17
- checking the status of parts and supplies 128
- cleaning
  - exterior of the printer 124
  - interior of the printer 124
- cleaning the printer 124
- cleaning the scanner 117, 125
- clearing jam
  - in door A 144
  - in the duplex unit 149
  - in trays 150
- collated printing does not work 157
- collating copies
  - copying 34
- computer
  - scanning to 46
- confidential documents do not print 159
- confidential print jobs 31
  - printing 31
- configuring daylight saving time 43
- configuring supply notifications 128
- configuring the settings
  - fax speaker 122
- configuring the SMTP server 35
- configuring the SMTP server for fax 37
- connecting a mobile device
  - to the printer wireless network 123
- connecting printer to distinctive ring service 43
- connecting the printer
  - to a wireless network 122
- connecting to a wireless network
  - using PIN method 123
  - using Push Button method 123
- conserving supplies 141
- contacting your dealer 187
- contacts
  - adding 18
  - deleting 19
  - editing 18
- control panel
  - using 13
- controller board
  - accessing 188
- copy troubleshooting
  - partial copies of documents or photos 184
  - poor copy quality 184
  - scanner does not respond 186
  - scanner unit does not close 186
- copying
  - creating shortcuts 34
  - multiple pages onto a single sheet 34
  - on both sides of the paper 33
  - on letterhead 33
  - photos 33
  - separator sheets between copies 34
- copying different paper sizes 33
- copying from
  - selected tray 33
- creating a shortcut
  - e-mail 36
- creating an e-mail shortcut 36
- creating shortcut
  - fax destination 44
  - FTP address 46
- crooked print 172
- customizing the display 17

## D

- date and time
  - fax settings 43
- daylight saving time, configuring 43
- deactivating the Wi-Fi network 124
- dealer
  - contacting 187

- default speaker volume
  - adjusting 122
- deleting contacts 19
- deleting groups 19
- different paper sizes, copying 33
- Display Customization
  - using 17
- distinctive ring service, fax
  - enabling 43
- dots on print 170

## E

- editing contacts 18
- editing groups 18
- emission notices 204, 211, 213
- enabling the USB port 155
- enabling Wi-Fi Direct 123
- encrypting
  - printer hard disk 120
- enlarging a copy size 34
- envelope seals when printing 156
- environmental setting
  - Hibernate mode 140
  - sleep mode 140
- erasing printer hard disk memory 119
- erasing printer memory 120
- Ethernet port 11
- exporting a configuration file
  - using the Embedded Web Server 201
- e-mail
  - creating a shortcut 36
- e-mail function
  - setting up 35
- e-mailing
  - using a shortcut number 35
  - using the address book 35
  - using the printer 35

## F

- fax
  - configuring the SMTP server 37
  - forwarding 45
  - holding 45
  - setting the schedule to send 44
- fax destination shortcut
  - creating 44
- fax log
  - viewing 45

- fax resolution
  - changing 44
- fax setup
  - country- or region-specific 40
  - standard telephone line connection 38
- fax speaker
  - configuring the settings 122
- fax troubleshooting
  - cannot receive faxes 182
  - cannot send faxes 182
  - cannot send or receive faxes 180
  - received fax has poor print quality 182
- faxing
  - adjusting darkness 44
  - changing resolution 44
  - setting the date and time 43
- FCC notices 211
- fine lines are not printed correctly 165
- firmware
  - update 202
- flash drive
  - printing from 29
  - scanning to 47
- folder paper 165
- font sample list
  - printing 32
- FTP address
  - creating shortcut 46
- FTP server, scanning to
  - using the control panel 47

## G

- Google Cloud Print
  - using 28
- groups
  - adding 18
  - deleting 19
  - editing 18

## H

- hardware options
  - trays 199
- hardware options, adding
  - print driver 201
- held documents do not print 159
- held jobs 31
  - printing 31

- Help menu 117
- Hibernate mode
  - configuring 140
- holding faxes 45
- home screen
  - customizing 16
  - using 14
- home screen icons 14
  - displaying 16

## I

- icons on the home screen
  - showing 16
- identifying jam locations 143
- imaging unit
  - ordering 128
  - replacing 131
- importing a configuration file
  - using the Embedded Web Server 201
- indicator light
  - printer status 13
- installing a printer hard disk 191
- installing an internal solutions port 193
- installing an optional card 190
- installing options
  - printer hard disk 191
- installing the printer software 200
- internal options
  - firmware card 188
  - installing 190
  - memory card 188
  - printer hard disk 191
- internal options, adding
  - print driver 201
- internal solutions port
  - installing 193

## J

- jammed pages are not reprinted 159
- jams
  - avoiding 142
- jams, clearing
  - in the automatic document feeder 152
  - in the multipurpose feeder 151
  - in the standard bin 149

job prints from the wrong tray 179  
job prints on the wrong paper 179  
junk faxes  
  blocking 45

## L

letterhead  
  copying on 33  
LINE port 11  
linking trays 23  
loading  
  multipurpose feeder 22  
loading envelopes  
  in the multipurpose feeder 22  
loading trays 20  
locating paper jams 143  
locating the security slot 119

## M

making copies 33  
managing screen saver 17  
Media Types menu 72  
menu  
  802.1x 98  
  About this Printer 62  
  Accessibility 56  
  Confidential Print Setup 113  
  Configuration Menu 57  
  Copy Defaults 73  
  Custom Scan Sizes 72  
  Device 116  
  Eco-Mode 52  
  Erase Temporary Data Files 114  
  Ethernet 94  
  E-mail Defaults 82  
  E-mail Setup 80  
  Fax 117  
  Fax Mode 76  
  Fax Server Setup 79  
  Fax Setup 76  
  Flash Drive Print 106  
  Flash Drive Scan 102  
  FTP Defaults 86  
  Google Cloud Print 101  
  HTML 69  
  HTTP/FTP Settings 99  
  Image 70  
  IPSec 97  
  Job Accounting 65

Layout 62  
Local Accounts 109  
Login Restrictions 113  
LPD Configuration 98  
Manage Permissions 108  
Media Types 72  
Menu Settings Page 116  
Miscellaneous 115  
Mobile Services  
  Management 115  
Network 117  
Network Overview 90  
Notifications 53  
Out of Service Erase 61  
PCL 68  
PDF 67  
PostScript 67  
Power Management 56  
Preferences 50  
Print 116  
Quality 64  
Remote Operator Panel 53  
Restrict external network  
  access 100  
Security Audit Log 110  
Setup 64  
Shortcuts 116  
SNMP 96  
Solutions LDAP Settings 115  
TCP/IP 95  
ThinPrint 99  
Tray Configuration 70  
Troubleshooting 117  
Universal Setup 71  
USB 100  
Visible Home Screen Icons 62  
Web Link Setup 86  
Wi-Fi Direct 101  
XPS 66  
Menu Settings Page  
  printing 14  
menus  
  Disk Encryption 114  
  Restore Factory Defaults 57  
  Schedule USB Devices 110  
  Wireless 91  
mobile device  
  printing from 28, 29  
mottled print 170  
moving the printer 9, 139

multiple pages onto a single sheet  
  copying 34  
multipurpose feeder  
  loading 22

## N

Network Setup Page  
  printing 15  
network setup page  
  printing 155  
noise emission levels 204  
Non-Printer Manufacturer supply 156  
non-volatile memory 120  
  erasing 119  
notices 204, 205, 206, 207, 211, 213

## O

operating systems  
  supported 200  
optional card  
  installing 190  
options  
  internal solutions port 193  
ordering  
  imaging unit 128  
  toner cartridge 128

## P

paper  
  Universal size setting 20  
paper curl 171  
paper jam in door A 144  
paper jam in the automatic document feeder 152  
paper jam in the duplex unit 149  
paper jam in the multipurpose feeder 151  
paper jam in the rear door 148  
paper jam in trays 150  
paper jam, clearing  
  in the automatic document feeder 152  
  in the multipurpose feeder 151  
  in the rear door 148  
paper jams  
  avoiding 142  
paper jams, clearing  
  in the standard bin 149



- paper sizes
    - supported 24
  - partial copies of documents or photos 184
  - parts status
    - checking 128
  - personal identification number method 123
  - photos
    - copying 33
  - pick roller assembly
    - replacing 135
  - pick tires
    - replacing 133
  - placing separator sheets
    - between copies 34
  - poor copy quality 184
  - poor fax print quality 182
  - power button light
    - printer status 13
  - power cord socket 11
  - print driver
    - hardware options, adding 201
  - print job
    - canceling from the computer 32
    - canceling from the printer control panel 32
  - print jobs not printed 162
  - print quality troubleshooting
    - blank pages 163
    - crooked print 172
    - dark print 163
    - fine lines are not printed correctly 165
    - folded or wrinkled paper 165
    - gray background on prints 166
    - horizontal light bands 167
    - light print 169
    - mottled print and dots 170
    - paper curl 171
    - repeating print defects 173
    - skewed print 172
    - solid black pages 174
    - text or images cut off 174
    - toner easily rubs off 175
    - vertical dark bands 175
    - vertical dark lines or streaks 176
    - vertical dark streaks with print missing 177
    - vertical light bands 177
    - vertical white lines 177
    - white pages 163
  - print troubleshooting
    - collated printing does not work 157
    - confidential and other held documents do not print 159
    - envelope seals when printing 156
    - incorrect margins 168
    - jammed pages are not reprinted 159
    - job prints from the wrong tray 179
    - job prints on the wrong paper 179
    - paper frequently jams 158
    - print jobs do not print 162
    - slow printing 160
    - tray linking does not work 157
    - unable to read flash drive 155
  - printer
    - minimum clearances 9
    - selecting a location 9
    - shipping 140
  - printer configurations 10
  - printer display
    - adjusting the brightness 140
  - printer hard disk
    - encrypting 120
  - printer hard disk memory 120
  - erasing 119
  - printer is not responding 178
  - printer menus 49
  - printer messages
    - Non-Printer Manufacturer supply 156
    - Replace cartridge, printer region mismatch 156
    - Scanner maintenance required, use ADF Kit 156
  - printer ports 11
  - printer settings
    - restoring to factory defaults 120
  - printer software
    - installing 200
  - printer wireless network
    - connecting a mobile device to 123
  - printing
    - confidential print jobs 31
    - font sample list 32
    - from a computer 28
    - from a flash drive 29
    - from a mobile device 28, 29
    - from an Android device 28
    - held jobs 31
    - Menu Settings Page 14
    - Network Setup Page 15
    - network setup page 155
    - quality test pages 117
    - using Google Cloud Print 28
    - using Wi-Fi Direct 29
  - printing a font sample list 32
  - printing a network setup page 155
  - printing from a computer 28
  - printing from a flash drive 29
  - Push Button method 123
- Q**
- Quality menu 64
- R**
- received fax
    - forwarding 45
  - received faxes
    - holding 45
  - reducing a copy size 34
  - removing jam
    - in the duplex unit 149
  - removing paper jam
    - in door A 144
    - in trays 150
  - repeat print jobs 31
  - repeating print defects 173
  - Replace cartridge, printer region mismatch 156
  - replacing supplies
    - imaging unit 131
    - toner cartridge 129
  - replacing the pick roller assembly 135
  - replacing the pick tires 133
  - restoring factory default settings 120
  - RJ11 adapter 40
  - running a slideshow 17
- S**
- safety information 7, 8
  - saving paper 34

- Scan Center
    - setting up 17
  - scan job not successful 185
  - scan troubleshooting
    - cannot scan from a computer 183
    - partial copies of documents or photos 184
    - poor copy quality 184
    - scanner does not respond 186
    - scanning freezes the computer 186
    - scanning takes too long 186
    - vertical dark streaks on output when scanning from the ADF 184
  - scanner
    - cleaning 125
  - Scanner maintenance required, use ADF Kit 156
  - scanner unit does not close 186
  - scanning
    - to a computer 46
    - to an FTP server 47
  - scanning quality problem 184
  - scanning to a flash drive 47
  - scanning to an FTP server
    - using the control panel 47
  - scheduling a fax 44
  - securing printer memory 120
  - security slot
    - locating 119
  - selecting a location for the printer 9
  - sending a fax
    - using the computer 43
    - using the control panel 43
  - sending an e-mail 35
  - setting the paper size 20
  - setting the paper type 20
  - setting the Universal paper size 20
  - setting up fax
    - country- or region-specific 40
    - standard telephone line connection 38
  - shipping the printer 140
  - Shortcut Center
    - using 16
  - shortcut, creating
    - fax destination 44
    - FTP address 46
  - shortcuts, creating
    - copy screen 34
  - skewed print 172
  - sleep mode
    - configuring 140
  - slow printing 160
  - SMTP server
    - configuring 35
  - SMTP server for fax
    - configuring 37
  - speaker
    - default volume 122
  - statement of volatility 120
  - storing print jobs 31
  - supplies
    - conserving 141
  - supplies status
    - checking 128
  - supplies, ordering
    - imaging unit 128
  - supply notifications
    - configuring 128
  - supported file types 30
  - supported flash drives 30
  - supported operating systems 200
  - supported paper sizes 24
  - supported paper types 26
  - supported paper weights 27
- T**
- toner cartridge
    - ordering 128
    - replacing 129
  - toner darkness
    - adjusting 179
  - tray linking does not work 157
  - trays
    - installing 199
    - linking 23
    - loading 20
    - unlinking 23
  - troubleshooting
    - cannot open Embedded Web Server 154
    - printer is not responding 178
  - troubleshooting, copy
    - partial copies of documents or photos 184
    - poor copy quality 184
    - scanner does not respond 186
  - troubleshooting, fax
    - received fax has poor print quality 182
  - troubleshooting, print
    - collated printing does not work 157
    - confidential and other held documents do not print 159
    - envelope seals when printing 156
    - incorrect margins 168
    - jammed pages are not reprinted 159
    - job prints from the wrong tray 179
    - job prints on the wrong paper 179
    - paper frequently jams 158
    - print jobs do not print 162
    - slow printing 160
  - troubleshooting, print quality
    - blank pages 163
    - crooked print 172
    - dark print 163
    - fine lines are not printed correctly 165
    - folded or wrinkled paper 165
    - gray background on prints 166
    - horizontal light bands 167
    - light print 169
    - mottled print and dots 170
    - paper curl 171
    - repeating print defects 173
    - skewed print 172
    - solid black pages 174
    - text or images cut off 174
    - toner easily rubs off 175
    - vertical dark bands 175
    - vertical dark lines or streaks 176
    - vertical dark streaks with print missing 177
    - vertical light bands 177
    - vertical white lines 177
    - white pages 163
  - troubleshooting, scan
    - partial copies of documents or photos 184
    - poor copy quality 184
    - scan job not successful 185
    - scanner does not respond 186
    - scanner unit does not close 186

- vertical dark streaks on output
  - when scanning from the ADF 184
- wrinkled paper 165
- two-sided copying 33

## U

- unable to read flash drive
  - troubleshooting, print 155
- understanding the status of the power button and indicator light 13
- Universal paper size
  - setting 20
- unlinking trays 23
- updating firmware
  - flash file 202
- USB port 11
  - enabling 155
- USB printer port 11
- using Display Customization 17
- using the ADF
  - copying 33
- using the control panel 13
- using the home screen 14
- using the scanner glass
  - copying 33

## V

- verify print jobs 31
- vertical dark lines on prints 176
- vertical dark streaks on output
  - when scanning from the ADF 184
- vertical streaks on prints 176
- viewing a fax log 45
- volatile memory 120
  - erasing 119

## W

- white lines 177
- Wireless menu 91
- wireless network
  - connecting the printer to 122
  - Wi-Fi Protected Setup 123
- wireless networking 122
- Wi-Fi Direct 123
  - printing from a mobile device 29
- Wi-Fi network
  - deactivating 124
- Wi-Fi Protected Setup
  - wireless network 123