



Product Catalog

Packaged Rooftop Air Conditioners Foundation™ Cooling and Gas/ Electric

15 to 25 Tons, 60 Hz





Introduction

Packaged Rooftop Air Conditioners

Through the years, Trane has designed and developed the most complete line of Packaged Rooftop products available in the market today.

Trane customers demanded a product that provided exceptional reliability, was easy to install, and was competitively priced. Trane listened and is proud to introduce the new Trane Foundation™ Light Commercial rooftop unit.

With Foundation, Trane continues to provide the highest standards in quality and reliability, comfort, performance, and ease of installation.

Trademarks

Trane and the Trane logo, Foundation, and Froststat are trademarks of Trane in the United States and other countries. All trademarks referenced in this document are the trademarks of their respective owners.

Revision Summary

Updated Electrical Data chapter.



Table of Contents

Features and Benefits	4
Standard and Optional Features at a Glance	4
Outstanding Standard Features	5
Variety of Options	8
Other Benefits	11
Application Considerations	12
Selection Procedure	13
Model Number Description	15
General Data	16
Performance Data	18
Controls	45
Economizer Controls	45
Thermostats	45
Electrical Data	46
Jobsite Connections	50
Dimensional Data	51
Weights	56
Mechanical Specifications	58



Features and Benefits

Foundation™ has features and benefits that make it first class in the light commercial rooftop market. Designed with input from field contractors and technicians, its convertible airflow and ease of installation are outstanding.

Standard and Optional Features at a Glance

Standard Features

- 2-inch throwaway filters
- 5kA SCCR (Short Circuit Current Rating)
- 5 year Limited Compressor Warranty
- 5 year Limited Heat Exchanger (15–17½ ton); 1 Year on 20 and 25 Tons
- 1 year Limited Parts Warranty
- All Heat Capacities Available in Vertical and Horizontal Discharge Configurations
- Belt Drive Motors
- Cleanable Condensate Drain Pan
- Colored and Numbered Wiring
- Convertible Airflow
- Cooling to 45°F
- Crankcase Heater (15–20 Tons)
- Discharge Line Thermostat
- Electromechanical Controls
- Easy Access Low Voltage Terminal Board (LTB)
- Foil-Faced and Edge Captured Insulation
- Froststat™
- High Pressure Cutout
- Liquid Line Refrigerant Drier
- Locking Safety Device with Anti-Short Cycle Timer
- Low Pressure Cutout
- Microchannel Type Condenser Coils
- Operating Charge of R-410A
- Phase Monitor
- Provisions for Through-the-Base Electrical
- Quick Access Panels
- Quick Adjust Fan Motor Mounting Plate
- Single Point Power
- Single Side Service
- Standardized Components
- Tubular Aluminized Steel heat Exchanger

Factory Installed Options

- Complete Coat™ Microchannel Condenser Coil
- Multi-Speed Indoor Fans (utilizing VFD)
- Stainless Steel Heat Exchanger with 10 Year Warranty
- Third Side Fork Access (Condenser)

Factory or Field Installed Options

- Barometric Relief¹
- Condensate Overflow Switch
- Economizer (Downflow)¹
- Electric Heaters

- Low Leak Economizer with Fault Detection and Diagnostics and 5 Year Limited Warranty - Downflow
- Manual Outside Air Dampers
- Motorized Outside Air Dampers
- Oversized Motor⁸
- Reference or Comparative Enthalpy Economizer
- Through the Base Electrical Access
- Through the Base Gas Piping
- Unit Mounted Non-Fused Disconnect Switch²

Field Installed Options

- 2-inch MERV 13 Throwaway Filters
- Crankcase Heater (25 Tons)
- Demand Control Ventilation with CO₂ Sensor
- Economizer (Horizontal)
- Hail Guard
- High Altitude Kit
- High and Low Static Drive Kits
- Low Ambient Kit
- Low Leak Economizer with Fault Detection and Diagnostics and 5 Year Limited Warranty - Horizontal
- LP Conversion Kit
- Powered Exhaust
- Remote Potentiometer
- Roof Curb
- Thermostat

Note: Explanation of Notes located in *"Model Number Description," p. 15.*

Other Benefits

- Cabinet Design Ensures Water Integrity
- Convertible Airflow - Downflow to Horizontal Airflow Configuration
- Ease of Service, Installation and Maintenance
- Mixed Model Build Enables "Fastest in the Industry" Ship Cycle Times
- Rigorous Testing
- Unmatched Product Support

Outstanding Standard Features

Colored and Numbered Wiring

Save time and money tracing wires and diagnosing the unit.

Compressors

Foundation™ contains the best compressor technology available to achieve the highest possible performance. Dual stages from manifold compressors are outstanding for humidity control and part load cooling conditions.

Controls—Electromechanical

This 24-volt control includes the control transformer and contactor pressure lugs for power wiring.



Features and Benefits

Convertible Units

Foundation units ship in the downflow configuration. A horizontal conversion kit, consisting of two downflow duct covers, is needed to convert the unit from a downflow to a horizontal airflow configuration. Units come complete with horizontal duct flanges so the contractor doesn't have to field fabricate them. These duct flanges are a time and cost saver. Units also have the ability to fit Trane and other competitors roof curbs (Carrier). In a matter of minutes, you can go from the Trane configuration to the Carrier configuration by simply changing the return air opening plate. This design allows for easy field conversion and eliminates the need for costly adapter curbs.

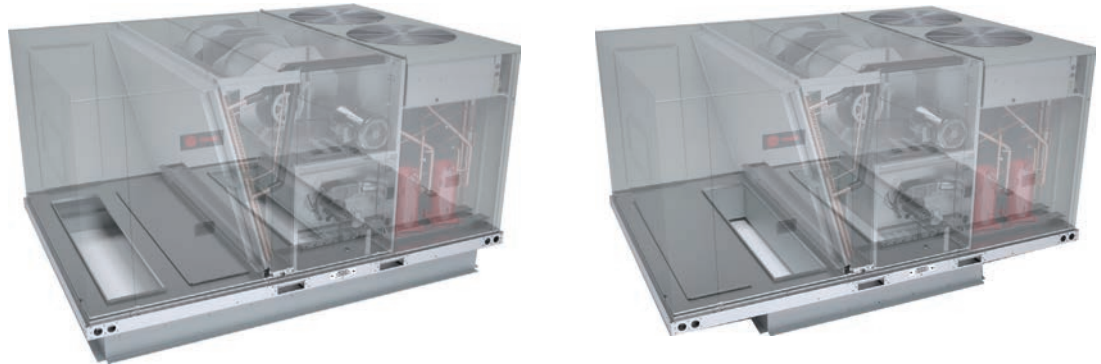

Crankcase Heaters (15 - 20 Tons)

These band heaters provide improved compressor reliability by warming the oil to prevent migration during off-cycles or low ambient conditions.

Discharge Line Thermostat

A bi-metal element discharge line thermostats installed as a standard feature on the discharge line of each compressor. This standard feature provides extra protection to the compressors against high discharge temperatures in case of loss of charge, extremely high ambient and other conditions which could drive the discharge temperature higher.

Efficiency

Product efficiencies meet the requirements of ASHRAE 90.1.

Easy Access Low Voltage Terminal Board

Foundation™ Low Voltage Terminal Board is mounted outside the main electrical control cabinet. It is extremely easy to locate and attach the thermostat control wiring and also test operation of all unit functions. This is another cost and time saving installation feature.

Foil Faced Insulation

All panels in the evaporator section of the unit have cleanable foil-faced insulation. All edges are either captured or sealed to ensure no insulation fibers get into the airstream.

Frostat™

This switch monitors coil temperature to prevent evaporator icing and protect the compressor.

Heat Exchanger

The cabinet features a tubular heat exchanger in, low, medium and high heat capacities, all of which are available for both vertical as well as horizontal discharge directions. The heat exchanger is fabricated using aluminized steel burners and corrosion-resistant aluminized steel tubes as standard on all models. As part of the heat exchanger assembly, an induced draft blower is used to pull the gas mixture through the burner tubes. A direct spark ignition system, which doubles as a safety device to prove the flame, is used to ignite the gas mixture.

Locking Safety Device with Anti-Short Cycle Timer

This device monitors compressor safety switch trips to prevent short cycling, protecting the compressor. A manual reset is required after a fourth safety switch trip.

Low Ambient Cooling

All Foundation units have cooling capabilities down to 45°F as standard.

Low Voltage Connections

The wiring of the low voltage connections to the unit and the thermostat is as simple as R-R, G-G, Y-Y, and W-W. This simplified system makes it easy for the installer to wire.

Microchannel Coils

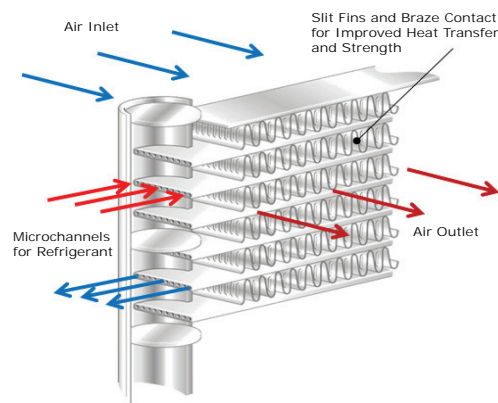

Microchannel coils are all-aluminum coils with fully-brazed construction. This design reduces risk of leaks and provides increased coil rigidity — making them more rugged on the jobsite. Their flat streamlined tubes with small ports and metallurgical tube-to-fin bond allow for exceptional heat transfer.

Microchannel all-aluminum construction provides several additional benefits:

- Light weight (simplifies coil handling)
- Easy to recycle
- Minimize galvanic corrosion

Motors

All indoor fan motors are belt drive as standard.

Pressure Cutouts

Low and high pressure cutouts are standard on all Foundation™ models.

Phase Monitor

Foundation features a three-phase line monitor module that protects against phase loss, phase reversal and phase unbalance. It is intended to protect compressors from reverse rotation. It has an operating input voltage range of 180–632 Vac, and LED indicators for ON and FAULT. There are no field adjustments and the module will automatically reset from a fault condition.

Quick-Access Panels

Remove three or less screws for access to the standardized internal components and wiring.

Quick-Adjust Fan Motor Mounting Plate

With the quick-adjust slider plate, the belt and sheaves can be quickly adjusted without moving the mounted fan motor. This results in reduced time spent on routine maintenance.

Single Point Power

A single electrical connection powers the unit and all on-board options.

Single Side Service

Single side service is standard on all units.



Features and Benefits

Sloped Drain Pans

Every Foundation™ unit has a non-corrosive, sloped drain pan made of rigid PVC - standard on all units - that is removable for easy cleaning.

Standardized Components

Components are placed in the same location on all Foundation units. Familiarize yourself with one Foundation and you are familiar with every Foundation. Due to standardized components throughout the Foundation line, contractors/owners can stock fewer parts.

Variety of Options¹

Factory Installed Options

Complete Coat™ Condenser Coil

The cathodic epoxy type electrodisposition coating is formulated for high edge build to a number of different types of heat exchangers. The coating is selected to provide excellent resistance and durability to corrosive effects of alkalies, acids, alcohols, petroleum, seawater, salt air, and corrosive environments.

Multi-Speed Indoor Fan System

Multi-speed indoor fan system is designed for use in applications for meeting the minimum requirement of CA Title 24. This system incorporates a multi-speed fan control to change the speed of the fan to 67% of full airflow based off compressor stages.

Stainless Steel Heat Exchanger

The optional stainless steel heat exchanger is constructed of 304 stainless steel tubes and 439 stainless steel burners. It is resistant to corrosion and oxidation and easy to clean. The high strength to weight ratio allows for high ventilation rates with gas units and comes standard with a modulating gas heat option. With this option, a 10-year stainless steel heat exchanger warranty is standard.

Third Side Fork Access

This option adds fork openings on the condenser end of the unit for ease of maneuvering the unit through narrow openings.

Factory or Field Installed Options

Barometric Relief

Designed to be used on downflow units, barometric relief is an unpowered means of relieving excess building pressure.

Condensate Overflow Switch

A condensate overflow switch is available to shut the unit down in the event that the condensate drain line becomes clogged. This option protects the unit from water overflowing from the drain pan and entering the base of the units.

Disconnect Switch

This accessory can be utilized as a convenient way to stock standard product without a disconnect and have the ability to use the through the base/disconnect offering. The standard disconnect is non-fused, 3-pole, case molded switch.

¹ Refer to "Model Number Description," p. 15 for option availability.

Economizer - Downflow

Economizers are equipped with either dry bulb, reference, or comparative enthalpy sensing. These economizers provide free cooling as the outdoor temperature and/or humidity decreases. Correctly installed, they offer valuable energy savings. Factory-installed economizers save time and ensure proper installation.

Note: *Factory-installed economizers require some field set-up.*

Electric Heaters

Electric heat modules are available within the basic unit. If ordering the Through the Base Electrical option with an Electrical Heater, the heater must be factory installed.

Low Leak Economizer with Fault Detection and Diagnostics - Downflow

This economizer meets the damper leakage requirements for ASHRAE 90.1, IECC, and California Title 24 standards (3 cfm/ft² at 1.0 in. w.g. for outside air dampers and 4 cfm/ft² for return dampers). Also, included as required per California Title 24:

- Fault Detection and Diagnostics system - provides detection of economizer faults. Barometric relief must be field installed with this option.
- Occupant Controlled Smart Thermostat (OCST) Connection - user-provided thermostat allows remote monitoring of economizer faults, and also provides the capability to receive load shedding commands from the utility company.

Manual Outside Air Damper

A 0–25 percent manual air damper is available.

Motorized Outside Air Damper

A 0–50 percent motorized outside air dampers is available.

Oversized Motors

Factory or field installed oversized motors are available for high static applications.

Note: *Field installed oversized motor is not available with multispeed option.*

Note: *10 hp oversized motor is factory installed only.*

Reference or Comparative Enthalpy

Measures and communicates humidity while maximizing comfort control.

Through-the-Base Electrical Utility Access

An electrical service entrance shall be provided allowing access for both control and main power connections inside the curb and through the base of the unit. This option will allow for field installation of liquid-tight conduit and an external field installed disconnect switch.

Factory provided through the base openings simplify wiring and piping. Because these utility openings frequently minimize the number of roof penetrations, the integrity of roofing materials is enhanced.

Through-the-Base Gas Piping (Gas Heat Units Only)

This option shall have all piping necessary including, black steel, manual gas shut-off valve, elbows, and union. This assembly will require minor field labor to install.

Field Installed Options

CO₂ Sensor - Demand Control Ventilation (DCV)

Demand-controlled ventilation (DCV) is a control strategy that responds to the actual demand (need) for ventilation by regulating the rate at which the HVAC system brings outdoor air into the



Features and Benefits

building. A CO₂ sensor measures the concentration (parts per million, ppm) of CO₂ in the air. As the CO₂ concentration changes, the outside air damper modulates to meet the current ventilation needs of the zone. DCV is a passive system; direct control of the indoor fan is not possible with standard or low leak economizers. The CO₂ sensor kit is available as a field installed accessory.

Crankcase Heaters (25 Tons)

These band heaters provide improved compressor reliability by warming the oil to prevent migration during off-cycles or low ambient conditions.

Economizer - Horizontal

Economizers are equipped with either dry bulb or reference or comparative enthalpy sensing. These economizers provide free cooling as the outdoor temperature and/or humidity decreases. Correctly installed, they offer a valuable energy savings.

High Altitude Kit

Requirement for units applies above 2000 feet. Derate gas orifices by 10%.

Low Leak Economizer with Fault Detection and Diagnostics - Horizontal

This economizer meets the damper leakage requirements for ASHRAE 90.1, IECC, and California Title 24 standards (3 cfm/ft² at 1.0 in. w.g. for outside air dampers and 4 cfm/ft² for return dampers). Also, included as required per California Title 24:

- Fault Detection and Diagnostics system - provides detection of economizer faults. Barometric relief must be field installed with this option.
- Occupant Controlled Smart Thermostat (OCST) Connection - user-provided thermostat allows remote monitoring of economizer faults, and also provides the capability to receive load shedding commands from the utility company.

LP Conversion Kit

Provided for field conversion of gas heat units from natural gas to propane.

Power Exhaust

This option is available on downflow units and provides exhaust of the return air, when using a downflow economizer, to maintain proper building pressurization. This is an excellent option for relieving most building overpressurization problems.

Remote Potentiometer

When installed in the economizer control circuitry, this accessory provides a method to remotely adjust the minimum damper position.

Roof Curbs

Available for downflow units. Only one roof curb for the entire Foundation™ line simplifies curb selection.

Static Drive Accessories

Available on many models, this high and low static drive accessories extend the capability of the standard motor. Avoid expensive motors by installing this optimized sheave accessory.

Thermostats

Available in programmable and non-programmable.

Tool-less Hail Guards

Tool-less, hail protection quality coil guards (pictured right) shall be field-installed for condenser coil protection. This option protects the condenser coil from vandalism and/or hail damage.



Other Benefits

Cabinet Integrity

For added water integrity, Foundation has a raised 1-1/8 inch lip around the supply and return of the downflow units to prevent water from blowing into the ductwork.

Easy to Install, Service and Maintain

Because today's owners are very cost-conscious when it comes to service and maintenance, Foundation was designed with direct input from service contractors. This valuable information helped to design a product that would get the service technician off the job quicker and save the owner money. Foundation does this by offering outstanding standard features enhanced by a variety of factory and field installed options, multiple control options, rigorously tested proven designs and superior product and technical support.

Outstanding Flexibility

The Foundation unit has the ability to adapt to specific Carrier WeatherMaker™ models without costly adapter curbs. This will save contractors money and make the installation an ease.

Rigorous Testing

All of Foundation's designs were rigorously rain tested at the factory to ensure water integrity. Foundation units incorporate either a one piece top or the Trane-Tite-Top (T3). Each part of the top overlaps in such a way that water cannot leak into the unit. These overlapped edges are gasketed and sealed to ensure superior water integrity.

Actual shipping tests were performed to determine packaging requirements. Units were test shipped around the country to determine the best packaging. Factory shake and drop tests were used as part of the package design process to help assure that the unit arrives at the job site in top condition.

Rigging tests include lifting a unit into the air and letting it drop one foot, assuring that the lifting lugs and rails hold up under stress. For the microchannel coils, the supplier will perform the leak check at 450 psig. The completely assembled refrigerant system is leak tested at a minimum of 225 psig with a refrigerant and nitrogen mixture.

All parts are inspected at the point of final assembly. Sub-standard parts are identified and rejected immediately. Every unit receives a 100% unit run test before leaving the production line to make sure it lives up to rigorous Trane requirements.

Unmatched Support

Trane Sales Representatives are a Support Group that can assist you with:

- Product
- Application
- Service
- Training
- Special Applications
- Specifications
- Computer Programs and much more



Application Considerations

Application of this product should be within the cataloged airflow and cooling considerations.

Barometric Relief

This product line offers an optional barometric relief damper for use in conjunction with economizer option. This accessory consists of gravity dampers which open with increased pressure. As building pressure increases, the pressure in the unit return air section also increases, opening the dampers and relieving the conditioned space.

Notes:

- *The effectiveness of barometric relief damper during economizing operation is system related.*
- *Pressure drop of the return air system should be considered to control building pressurization.*

Clearance Requirements

The recommended clearances identified with unit dimensions should be maintained to ensure adequate serviceability, maximum capacity and peak operating efficiency. Actual clearances which appear inadequate should be reviewed with local Trane sales personnel.

Complete Coat™ Microchannel Condenser Coil

The cathodic epoxy type electrodisposition coating is formulated for high edge build to a number of different types of heat exchangers. The coating is selected to provide excellent resistance and durability to corrosive effects of alkalies, acids, alcohols, petroleum, seawater, salt air, and corrosive environments. This coating shall be available on microchannel condenser coils.

Condensate Trap

The evaporator is a draw-through configuration. A trap must be field provided prior to start-up on the cooling cycle.

Heating Operation

The heat exchanger is manufactured with aluminized steel. To prevent condensation within the heat exchanger, do not exceed 50 percent outside air or a minimum mixed air temperature of 40°F.

Optional Stainless Steel Heat Exchanger

The optional stainless steel heat exchanger is manufactured with 304 stainless steel tubes and 439 stainless steel burners. To prevent corrosion and prolong heat exchanger reliability, the minimum mixed air temperature allowed across the heat exchanger is 40°F. Whenever high outside air or outside applications exist, this option should be utilized.

Low Ambient Cooling

The Foundation line features low ambient cooling down to 45°F. The following options need to be included/considered when low ambient applications are required: continuous fan operation, crankcase heaters, froststat. Contact your local Trane Representative for more assistance with low ambient cooling applications.

Unit Pitch

These units have sloped condensate drain pans. Units must be installed level. Any unit slope must be toward access side of the unit.



Selection Procedure

Cooling Capacity

Note: Cooling Capacity Procedure is the same for cooling (E) and gas/electric (G).

Step 1.

Calculate the building's total and sensible cooling loads at design conditions. Use the following calculation methods or any other standard accepted method. Factors used in unit selection:

Total Cooling Load: 180 MBh

Sensible Cooling Load: 126 MBh

Airflow: 6000 cfm

Electrical Characteristics: 460/60/3

Summer Design Conditions: Entering Evaporator Coil: 80 DB, 67 WB Outdoor Ambient: 95 DB

External Static Pressure: 0.38 in. wg

Rooftop—downflow configuration

Accessories

- Roof curb
- Economizer
- Electric Heat

Step 2.

As a starting point, a rough determination must be made of the size of the unit. The final selection will be made after examining the performance at the given conditions. Divide the total cooling load by nominal Btu/h per ton (12 MBh per ton); then round up to the nearest unit size.

$$180 \text{ MBh} / 12 \text{ MBh} = 15.0 \text{ tons}$$

Step 3.

Table 3, p. 18 shows that a EBC180A4 has a **gross** cooling capacity of 187.2 MBh and 143 MBh sensible capacity at 6000 cfm and 95 DB outdoor ambient with 80 DB, 67 WB air entering the evaporator.

To Find Capacity at Intermediate Conditions Not in the Table.

When the design conditions are between values that are identified in the capacity table, interpolation is required to approximate the capacity.

Note: Extrapolation outside of the table conditions is not recommended.

Step 4.

In order to select the correct unit which meets the building's requirements, the fan motor heat must be deducted from the gross cooling capacity. The amount of heat that the fan motor generates is dependent on the effort by the motor—cfm and static pressure. To determine the total unit static pressure you add the external static pressure to the additional static related by the added features:

External Static Duct System	0.38 wg
Standard Filter 2 in. from Table 31, p. 43	0.05 wg
Economizer from Table 31, p. 43 (100% Return Air)	0.04 wg
Electric Heater Size 36 kW from Table 31, p. 43	0.07 wg
(Reference "Heating Capacity," p. 14 for determination of heater size.) No additional static add for gas/heat exchanger.	
Total Static Pressure	0.55 wg

Note: The Evaporator Fan Performance Table 9, p. 24 has already accounted for the pressure drop for standard filters and wet coils (see note below Table 9). Therefore, the actual total static pressure is 0.55 - 0.05 (from Table 31, p. 43 = 0.50 wg).



Selection Procedure

With 6000 cfm and 0.50 wg.

[Table 9, p. 24](#) shows 1.37 bhp for this unit. Note below the table gives a formula to calculate Fan Motor Heat,

$$3.15 \times \text{bhp} = \text{MBh.}$$

$$3.15 \times 1.37 = 4.32 \text{ MBh.}$$

Now subtract the fan motor heat from the gross cooling capacity of the unit:

$$\begin{aligned} \text{Net Total Cooling Capacity} \\ = 187.2 \text{ MBh} - 4.32 = 182.88 \text{ MBh.} \end{aligned}$$

$$\begin{aligned} \text{Net Sensible Cooling Capacity} \\ = 143 \text{ MBh} - 4.32 = 138.68 \text{ MBh.} \end{aligned}$$

Step 5.

If the performance will not meet the required load of the building—total or sensible cooling load, try a selection at the next higher size unit.

Heating Capacity

Note: Heating capacity procedures DIFFER for cooling (E) and gas/electric (G) units.

Step 1.

Calculate the building heating load.

Step 2.

Size the system heating capacity to match the calculated building heating load. The following are building heating requirements:

460 volt/3 phase Power Supply
Total heating load of 115.0 MBh
6000 cfm

The electric heat accessory capacities are listed in [Table 33, p. 44](#). From the table, a 36 kW heater will deliver 122.94 MBh at 480 volts. In order to determine capacity at 460 volts, the heater voltage correction factor from [Table 34, p. 44](#) must be used. Therefore, 122.94 MBh x 0.94 (voltage correction factor) = 115.6 MBh.

Gas/electric: Fuel natural gas total heating load of 195 MBh. [Table 32, p. 43](#) shows 250 MBh and 350 MBh input models. The output capacities of these furnaces are 203 MBh and 284 MBh respectively. The low heat model with 203 MBh output best matches the building requirements.

Air Delivery Selection

Note: Air Delivery procedures is the same for cooling (E) and gas/electric (G) units.

External static pressure drop through the air distribution system has been calculated to be 0.50 inches of water. From [Table 31, p. 43](#) static pressure drop through the economizer is 0.04 and the 36 kW heater is 0.07 inches of water (0.38 + 0.04 + 0.07). Enter [Table 9, p. 24](#) for a EBC180A4 at 6000 cfm and 0.50 static pressure. The standard motor with the low static drive accessory at 622 rpm will give the desired airflow at a rated bhp of 1.37.



Model Number Description

Digit 1 – Unit Type

- E = Packaged Cooling, Electric Heat
- G = Packaged Gas/Electric

Digit 2 – Efficiency

- B = ASHRAE 90.1 - 2013

Digit 3 – Airflow Configuration

- C = Convertible

Digit 4, 5, 6 – Nominal Gross Cooling Capacity (MBh)

- 180 = 15 Tons
- 210 = 17½ Tons
- 240 = 20 Tons
- 300 = 25 Tons

Digit 7 – Major Design

Sequence

- A

Digit 8 – Voltage Selection

- 3 = 208-230/60/3
- 4 = 460/60/3
- W = 575/60/3
- K = 380/60/3^{6, 7}

Digit 9 – Unit Controls

- E = Electromechanical

Digit 10 – Heating Capacity

Note: (Applicable to Digit 1 = E models only)

- 0 = No Heat
- G = 18 kW Electric Heat
- N = 36 kW Electric Heat
- P = 54 kW Electric Heat
- R = 72 kW Electric Heat

Note: (Applicable to Digit 1 = G models only)

- H = Gas Heat - High
- L = Gas Heat - Low
- M = Gas Heat - Medium
- X = Gas Heat - SS Ht Ex - Low
- Y = Gas Heat - SS Ht Ex - Medium
- Z = Gas Heat - SS Ht Ex - High

Digit 11 – Minor Design

Sequence

Digit 12, 13 – Service Sequence

- 00 = None

Digit 14 – Fresh Air Selection³

- 0 = No Fresh Air
- A = Manual Outside Air Damper 0-25%
- B = Motorized Outside Air Damper 0-50%
- C = Economizer, Dry Bulb 0-100% without Barometric Relief⁴
- D = Economizer, Dry Bulb 0-100% with Barometric Relief^{1, 4}
- E = Economizer, Reference Enthalpy 0-100% without Barometric Relief⁴
- F = Economizer, Reference Enthalpy 0-100% with Barometric Relief^{1, 4}

- G = Economizer, Comparative Enthalpy 0-100% without Barometric Relief⁴
- H = Economizer, Comparative Enthalpy 0-100% with Barometric Relief^{1, 4}
- J = Downflow Low Leak Economizer, Dry Bulb w/o Barometric Relief⁴
- L = Downflow Low Leak Economizer, Reference Enthalpy w/o Barometric Relief⁴
- N = Downflow Low Leak Economizer, Comparative Enthalpy w/o Barometric Relief⁴

Digit 15 – Supply Fan/Drive Type/Motor

- 0 = Standard Motor
- 1 = Oversized Motor⁸
- 7 = Multi-Speed Standard Motor
- 9 = Multi-Speed Oversized Motor

Digit 16 – Access

- 0 = Standard Fork Access
- F = Third Side Condenser Fork Access (15-25 Ton)

Digit 17 – Condenser Coil Protection

- 0 = Standard Coil
- 4 = CompleteCoat™ Condenser Coil

Digit 18 – Through The Base Provisions

Note: Applicable to Digit 1, E models.

- 0 = No Through The Base Provisions
- A = Through The Base Electric

Note: Applicable to Digit 1, G models only.

- 0 = No Through The Base Provisions
- A = Through The Base Electric
- B = Through-the-Base Gas¹
- C = Through-the-Base Electric/Gas

Digit 19 – Disconnect Switch

- 0 = No Disconnect
- 1 = Unit Mounted Non-Fused Disconnect Switch²

Digit 20 – Not Used

Digit 21 – Not Used

Digit 22 – Not Used

Digit 23 – Not Used

Digit 24 – Not Used

Digit 25 - System Monitoring Controls

- 0 = No Monitoring Controls
- A = Condensate Drain Pan Overflow Switch

Digit 26

- B = Economizer Fault Detection and Diagnostics (FDD)⁵

Model Number Notes

1. Some field set up required.
2. Must be ordered with Through-the-Base Electrical option.
3. All Factory Installed Options are Built-to-Order. Check order services for estimated production cycle.
4. Factory installed economizers only available in downflow configuration.
5. Fault Detection and Diagnostics (FDD) is available on Low Leak Economizers only.
6. Available on Digit 1 = E units only.
7. Unit will operate reliably at 400V.
8. 10 hp oversized motor is factory installed only.



General Data

Table 1. General data – 15-25 tons

	15 Ton	17½ Ton	20 Ton	25 Ton	
	E/GBC180	E/GBC210	E/GBC240	EBC300	GBC300
Cooling Performance^(a)					
Gross Cooling Capacity	180,000	212,000	256,000	284,000	284,000
EER (Downflow/Horizontal)	11	11	10	10	9.8
Nominal Airflow CFM / AHRI Rated CFM	6000 / 4800	7000 / 6650	8000 / 7000	10,000 / 8000	10,000 / 8000
AHRI Net Cooling Capacity	176,000	206,000	244,000	268,000	268,000
Integrated Energy Efficiency Ratio (IEER) (One Speed Fan / Multi Speed Fan)	12.4 / 13.2	12.4 / 13.2	11.6 / 12.4	11.6 / 12.4	11.4 / 12.4
Percent Capacity @ part load (Stage 1/Stage 2)	53 / 100	50 / 100	54 / 100	53 / 100	53 / 100
System Power (kW)	16.00	18.73	24.4	26.8	27.35
Compressor					
Number/Type	2 / Scrolls	2 / Scrolls	2 / Scrolls	2 / Scrolls	2 / Scrolls
Sound					
Outdoor Sound Rating (BELS)	9.5	9.5	9.5	9.5	9.5
Outdoor Coil					
Type	Microchannel	Microchannel	Microchannel	Microchannel	Microchannel
Coil Width (in.)	0.71	1.0	1.0	1.0	1.0
Face Area (sq. ft.)	34.74	34.74	34.74	34.74	34.74
Rows/FPI	1 / 23	1 / 21	1 / 23	1 / 23	1 / 23
Indoor Coil					
Type	Microchannel	Microchannel	Microchannel	Microchannel	Microchannel
Tube Size (in.) ID	1	1	1	1	1
Face Area (sq. ft.)	26.00	26.00	26.00	26.00	26.00
Rows/FPI	2 / 18	2 / 18	2 / 18	4 / 15	4 / 15
Refrigerant Control	TXV	TXV	TXV	TXV	TXV
Drain Connection Number/Size (in.)	1 / 1.00 PVC Pipe Female	1 / 1.00 PVC Pipe Female	1 / 1.00 PVC Pipe Female	1 / 1.00 PVC Pipe Female	1 / 1.00 PVC Pipe Female
Outdoor Fan					
Type	Propeller	Propeller	Propeller	Propeller	Propeller
Number Used/Diameter (in.)	2 / 28	2 / 28	2 / 28	2 / 28	2 / 28
Drive Type/No. Speeds	Direct / 1	Direct / 1	Direct / 1	Direct / 1	Direct / 1
cfm	15,900	15,900	15,900	15,900	15,900
Number Motors/hp	2 / 1.0	2 / 1.0	2 / 1.0	2 / 1.0	2 / 1.0
Motor rpm	1125	1125	1125	1125	1125
Indoor Fan					
Type	FC Centrifugal	FC Centrifugal	FC Centrifugal	FC Centrifugal	FC Centrifugal
Number Used/Diameter (in.)	2 / 15x15	2 / 15x15	2 / 15x15	2 / 15x15	2 / 15x15
Drive Type/No. Speeds	Belt / 1	Belt / 1	Belt / 1	Belt / 1	Belt / 1
Number Motors	1	1	1	1	1
Motor hp (Standard/Oversized)	3.0 ^(b) / 5.0	5.0 / 7.5	5.0 / 7.5	7.5 / 10.0 ^(c)	7.5 / 10.0 ^(c)
Motor rpm (Standard/Oversized)	1750 (380V = 3450) / 3450	3450 / 3450 (380V = 3470)	3450 / 3450 (380V = 3470)	3450 (380V = 3470) / 1750	3450 (380V = 3470) / 1750
Motor Frame Size (Standard/Oversized)	145T / 145T	145T / 184T	145T / 184T	184T / 215T	184T / 215T

Table 1. General data – 15-25 tons (continued)

	15 Ton	17½ Ton	20 Ton	25 Ton	
	E/GBC180	E/GBC210	E/GBC240	EBC300	GBC300
Filters					
Type Furnished ^(d)	Throwaway	Throwaway	Throwaway	Throwaway	Throwaway
Number Size Recommended	(8) 20x25x2	(8) 20x25x2	(8) 20x25x2	(8) 20x25x2	(8) 20x25x2
Refrigerant Charge (Pounds of R-410A)^(e)					
Circuit 1	14.6	15.2	16.5	17.8	17.8

(a) Units are AHRI Certified to AHRI Standard 340-360 (I-P). Rating conditions are 95F outdoor air temperature, 80F entering dry bulb, 67F entering wet bulb with minimum external static pressure as determined by rating standard.

(b) 3.0hp motor is not available on 380V units.

(c) 10.0hp oversized motor is not available on 380V units.

(d) Optional field-installed MERV 13 filters available.

(e) Refrigerant charge is an approximate value. For a more precise value, see unit nameplate and service instructions.

Table 2. General data—heating performance – 15-25 tons

Heating Models	Heating Performance ^(a)					
	15 Tons			17½ - 25 Tons		
	Low	Medium	High	Low	Medium	High
Heating Input (Btu/h)	240,000	320,000	350,000	240,000	320,000	400,000
1st Stage (Btu)	168,000	224,000	245,000	168,000	224,000	280,000
Heating Output (Btu/h)	192,000	256,000	280,000	192,000	256,000	320,000
1st Stage (Btu)	134,500	179,200	196,000	134,500	179,200	224,000
Steady State Efficiency%	80%	80%	80%	80%	80%	80%
No. Burners	6	8	8	6	8	8
No. Stages	2	2	2	2	2	2
Gas Supply Line Pressure (in. wc)						
Natural Gas (minimum/maximum)	4.5 / 14.0 in. wc.	4.5 / 14.0 in. wc.	5.0 / 14.0 in. wc.	4.5 / 14.0 in. wc.	4.5 / 14.0 in. wc.	5.5 / 14.0 in. wc.
LP (minimum/maximum)	11.0/14.0 in. wc.	11.0/14.0 in. wc.	11.0/14.0 in. wc.	11.0/14.0 in. wc.	11.0/14.0 in. wc.	11.0/14.0 in. wc.
Gas Connection Pipe Size (in.)	3/4"	3/4"	3/4"	3/4"	3/4"	3/4"

(a) Heating Performance limit settings and rating data were established and approved under laboratory test conditions using American National Standards Institute standards (ANSI). Ratings shown are for elevations up to 2000 feet. For elevations above 2000 feet, ratings should be reduced at the rate of 4% for each 1000 feet above sea level.



Performance Data

Table 3. Gross cooling capacities 15 tons - E/GBC180A3,4,W,K

Air Flow cfm	Ent DB (°F)	Ambient Temperature																	
		85						95						105					
		Entering Wet Bulb																	
		61		67		73		61		67		73		61		67		73	
MBh	SHC	MBh	SHC	MBh	SHC	MBh	SHC	MBh	SHC	MBh	SHC	MBh	SHC	MBh	SHC	MBh	SHC		
4800	75	166.5	134.8	190.7	107.0	209.9	70.8	158.0	130.5	180.8	102.6	197.5	65.9	149.1	126.0	170.2	97.9	184.3	64.1
	80	165.7	157.3	190.1	131.6	210.6	100.2	157.3	152.8	180.4	127.1	198.3	95.4	148.4	148.1	170.0	122.4	184.8	90.1
	85	170.6	170.6	189.7	156.5	211.5	126.2	164.0	164.0	180.0	152.1	199.6	121.0	156.8	156.8	169.7	146.2	186.2	115.6
	90	181.5	181.5	188.9	178.6	211.4	151.1	174.5	174.5	179.2	173.9	199.4	146.2	166.9	166.9	168.8	168.8	186.1	140.8
5400	75	170.4	143.7	194.9	112.4	213.8	75.6	161.6	136.7	184.4	107.8	200.7	70.6	152.2	129.8	173.3	102.3	186.8	65.4
	80	169.2	167.8	194.5	139.8	213.9	104.6	160.5	160.5	184.2	135.2	201.1	99.7	152.5	152.5	173.3	130.3	187.7	94.6
	85	178.0	178.0	193.9	164.5	214.9	132.9	170.9	170.9	183.4	161.2	202.1	127.8	163.2	163.2	172.4	156.0	187.8	122.2
	90	189.3	189.3	192.4	191.2	214.8	161.2	181.7	181.7	182.3	182.3	202.0	156.1	173.3	173.3	173.5	173.5	187.7	150.5
6000	75	173.5	146.8	198.1	116.8	216.9	77.1	163.8	145.7	187.5	112.1	203.2	71.9	154.0	140.7	176.1	107.1	193.2	68.1
	80	172.3	172.3	197.9	147.7	217.1	109.1	165.2	165.2	187.2	143.0	203.9	104.0	157.5	157.5	175.8	138.0	190.1	99.0
	85	184.3	184.3	196.5	175.7	217.4	139.7	176.7	176.7	185.7	170.7	203.9	134.5	168.5	168.5	174.2	165.4	190.0	129.1
	90	196.0	196.0	196.2	196.2	217.3	171.0	187.7	187.7	187.9	187.9	203.9	165.0	178.2	178.2	178.4	178.4	189.8	153.4
6600	75	175.2	157.9	201.2	121.6	219.5	78.4	165.6	153.0	190.1	116.7	205.2	73.1	155.5	147.9	178.2	111.6	196.4	69.8
	80	177.4	177.4	200.6	155.4	219.8	113.4	169.9	169.9	189.5	150.5	206.5	107.4	161.8	161.8	177.7	144.5	191.9	101.8
	85	189.8	189.8	198.5	185.0	219.7	146.6	181.7	181.7	187.3	179.9	206.1	141.3	172.9	172.9	175.4	174.5	191.6	135.8
	90	201.5	201.5	201.7	201.7	219.4	175.4	192.4	192.4	192.6	192.6	205.0	172.9	181.9	181.9	182.0	182.0	190.3	167.0
7200	75	176.8	164.9	203.5	126.2	221.5	79.7	166.9	159.9	192.0	121.2	206.7	74.3	156.5	154.8	179.8	115.9	199.0	71.3
	80	181.9	181.9	202.7	162.8	222.0	116.5	174.1	174.1	191.4	154.6	208.0	111.0	165.5	165.5	178.7	150.2	193.5	105.4
	85	194.6	194.6	199.8	194.0	222.0	153.4	186.0	186.0	188.3	188.3	207.8	148.0	176.5	176.5	176.6	176.6	192.8	142.4
	90	206.0	206.0	206.2	206.2	220.2	187.2	196.1	196.1	196.3	196.3	206.0	181.5	184.3	184.3	184.4	184.4	190.8	175.5
Air Flow cfm	Ent DB (°F)	Ambient Temperature																	
		115						120						125					
		Entering Wet Bulb																	
		61		67		73		61		67		73		61		67		73	
MBh	SHC	MBh	SHC	MBh	SHC	MBh	SHC	MBh	SHC	MBh	SHC	MBh	SHC	MBh	SHC	MBh	SHC		
4800	75	139.5	118.4	158.7	92.9	169.9	58.7	134.4	114.3	152.5	89.7	161.9	55.8	129.0	110.9	146.2	86.9	153.2	52.6
	80	139.2	139.2	158.7	117.4	170.9	84.9	135.2	135.2	152.7	114.8	163.3	82.1	130.9	130.9	146.2	111.9	155.3	79.1
	85	149.0	149.0	158.3	140.8	171.3	109.8	144.7	144.7	152.2	138.0	163.8	106.9	140.0	140.0	145.6	135.0	155.7	103.8
	90	158.3	158.3	158.4	158.4	171.1	135.0	153.3	153.3	153.5	153.5	163.6	132.1	147.8	147.8	147.9	147.9	155.4	128.6
5400	75	141.7	128.1	161.5	97.1	171.4	59.7	136.3	125.3	155.2	94.4	170.4	59.2	130.7	122.5	148.4	91.5	153.7	53.4
	80	144.5	144.5	161.4	125.2	173.3	89.1	140.2	140.2	155.1	122.4	165.6	86.4	135.6	135.6	148.3	119.5	157.6	83.7
	85	154.6	154.6	160.4	150.5	173.3	116.6	149.8	149.8	153.9	147.5	165.3	113.6	144.6	144.6	147.0	144.4	156.6	110.3
	90	163.4	163.4	163.6	163.6	173.1	142.2	157.6	157.6	157.7	157.7	167.8	140.2	150.8	150.8	150.9	150.9	160.6	138.5
6000	75	143.4	135.4	163.7	101.7	180.2	63.3	137.9	132.6	157.1	98.8	163.5	57.6	132.0	129.7	150.1	95.8	154.0	54.3
	80	149.1	149.1	163.5	132.7	175.5	92.4	144.5	144.5	156.8	129.2	167.5	89.4	139.5	139.5	149.6	125.8	158.9	86.1
	85	159.1	159.1	161.7	159.7	174.6	123.3	153.9	153.9	155.0	155.0	166.2	120.1	148.0	148.0	148.1	148.1	157.2	116.8
	90	166.9	166.9	167.0	167.0	173.8	152.2	159.8	159.8	159.9	159.9	169.8	150.5	152.7	152.7	152.8	152.8	162.9	147.8
6600	75	144.7	142.5	165.4	106.1	173.1	61.7	138.9	138.9	158.6	103.1	164.0	58.5	133.0	133.0	151.3	100.0	168.7	59.8
	80	152.9	152.9	165.0	135.1	176.7	96.0	148.0	148.0	157.5	135.3	168.4	92.8	142.7	142.7	150.1	132.0	159.7	89.4
	85	162.7	162.7	162.8	162.8	179.9	131.3	156.9	156.9	157.0	157.0	173.1	128.7	150.2	150.2	150.3	150.3	157.6	123.1
	90	168.7	168.7	168.9	168.9	174.0	160.7	162.2	162.2	162.3	162.3	171.6	159.6	158.6	158.6	158.7	158.7	164.6	156.9
7200	75	145.4	145.4	166.7	110.3	185.1	66.4	140.4	140.4	159.7	107.3	178.0	63.8	135.4	135.4	152.2	104.1	154.9	56.3
	80	156.1	156.1	165.2	144.7	177.7	99.3	150.9	150.9	158.0	141.6	169.2	96.1	145.2	145.2	150.3	138.2	160.3	92.6
	85	165.4	165.4	165.5	165.5	176.4	136.3	158.9	158.9	159.0	159.0	167.3	132.0	151.4	151.4	151.5	151.5	157.5	128.5
	90	171.3	171.3	171.4	171.4	179.9	171.1	168.2	168.2	168.4	168.4	173.0	168.4	163.1	163.1	163.2	163.2	165.9	165.7

Notes:

1. All capacities shown are gross and have not considered indoor fan heat. To obtain **NET** cooling capacity subtract indoor fan heat. For indoor fan heat formula, refer to appropriate airflow table notes.
2. MBh = Total Gross Capacity
3. SHC = Sensible Heat Capacity

Table 4. Gross cooling capacities 17½ tons - E/GBC210A3,4,W,K

Air Flow cfm	Ent DB (°F)	Ambient Temperature																	
		85				95				105									
		Entering Wet Bulb																	
		61		67		73		61		67		73		61		67		73	
MBh	SHC	MBh	SHC	MBh	SHC	MBh	SHC	MBh	SHC	MBh	SHC	MBh	SHC	MBh	SHC	MBh	SHC	MBh	SHC
5600	75	192.3	156.3	219.9	124.4	243.4	83.6	183.0	151.6	208.7	119.4	229.2	81.9	173.1	146.6	196.7	114.1	213.5	75.9
	80	190.3	180.4	219.2	152.4	243.6	117.0	181.1	175.4	208.1	147.3	229.6	111.5	171.3	170.1	196.1	142.0	214.1	105.5
	85	194.5	194.5	217.7	180.4	243.8	146.3	187.4	187.4	206.9	175.4	230.1	140.4	179.6	179.6	195.1	166.8	215.0	134.3
	90	206.5	206.5	215.8	204.0	243.3	174.3	198.9	198.9	204.9	198.6	229.7	168.8	190.5	190.5	193.1	192.9	214.7	162.9
6300	75	196.8	166.2	225.0	130.6	247.4	89.1	187.0	159.9	213.1	125.3	232.4	83.4	176.6	151.5	200.4	120.0	216.9	77.5
	80	193.9	191.6	224.0	161.5	247.9	122.1	184.2	184.2	212.3	156.3	233.2	116.4	174.9	174.9	199.7	150.8	217.2	110.4
	85	202.6	202.6	222.3	188.1	248.3	154.0	194.9	194.9	210.4	184.7	233.7	148.2	186.4	186.4	197.8	178.8	217.6	142.0
	90	215.1	215.1	219.4	217.4	247.6	185.7	206.8	206.8	207.9	207.9	233.2	180.1	197.4	197.4	197.6	197.6	217.4	173.9
7000	75	200.2	170.2	229.0	136.5	250.8	90.6	189.4	167.9	216.7	130.5	235.6	84.9	178.4	162.3	203.5	124.7	219.6	79.0
	80	196.5	196.5	227.8	170.3	251.5	127.0	188.8	188.8	215.6	165.0	236.1	121.3	180.5	180.5	202.5	159.3	220.0	115.3
	85	209.6	209.6	225.0	200.7	251.7	161.8	201.3	201.3	212.8	194.9	236.5	155.9	192.2	192.2	199.6	188.8	219.8	149.5
	90	222.4	222.4	222.6	222.6	250.9	196.9	213.4	213.4	213.6	213.6	236.0	191.1	203.1	203.1	203.3	203.3	219.5	177.8
7700	75	202.0	181.2	232.5	141.3	253.9	92.2	191.3	175.7	219.8	135.8	238.4	86.5	180.0	169.9	206.0	129.9	221.7	80.5
	80	202.2	202.2	230.8	178.8	254.5	131.8	194.1	194.1	218.2	173.4	238.9	126.0	185.2	185.2	204.6	167.2	222.4	119.0
	85	215.6	215.6	226.9	210.5	254.4	169.4	206.9	206.9	214.3	204.6	238.6	163.4	197.1	197.1	200.7	198.5	221.8	157.0
	90	228.7	228.7	228.9	228.9	253.6	203.5	219.0	219.0	219.1	219.1	237.5	198.5	207.7	207.7	207.9	207.9	219.8	191.2
8400	75	203.5	188.6	235.5	146.5	256.8	93.9	192.5	183.0	222.2	140.8	240.7	88.0	180.9	177.2	207.9	134.8	223.5	81.9
	80	207.2	207.2	233.2	187.1	257.3	135.9	198.7	198.7	220.2	178.4	241.2	129.6	189.3	189.3	205.5	172.8	224.5	123.3
	85	221.0	221.0	228.2	220.0	256.6	176.9	211.6	211.6	215.2	214.1	240.4	170.8	201.2	201.2	201.3	201.3	223.4	164.4
	90	234.2	234.2	234.3	234.3	254.5	214.1	223.6	223.6	223.8	223.8	238.0	207.4	211.4	211.4	211.5	211.5	220.1	200.2
Air Flow cfm	Ent DB (°F)	Ambient Temperature																	
		115				120				125									
		Entering Wet Bulb																	
		61		67		73		61		67		73		61		67		73	
MBh	SHC	MBh	SHC	MBh	SHC	MBh	SHC	MBh	SHC	MBh	SHC	MBh	SHC	MBh	SHC	MBh	SHC	MBh	SHC
5600	75	162.4	140.1	183.4	108.3	197.4	69.8	156.6	134.9	176.1	105.3	188.4	66.6	150.5	130.4	168.3	102.0	178.7	63.0
	80	160.7	160.7	183.0	136.2	197.8	99.4	156.0	156.0	175.8	133.1	189.1	96.2	151.1	151.1	168.0	129.7	179.7	92.8
	85	170.8	170.8	181.9	162.0	198.0	127.7	165.9	165.9	174.6	158.6	189.4	124.4	160.4	160.4	166.8	155.0	180.0	120.9
	90	180.7	180.7	180.9	180.9	197.7	156.3	175.0	175.0	175.2	175.2	189.0	153.0	168.5	168.5	168.6	168.6	179.7	149.2
6300	75	164.8	148.4	186.5	113.4	199.8	71.3	158.7	145.2	178.9	110.1	190.4	67.9	152.2	141.9	170.7	106.6	180.2	64.3
	80	166.3	166.3	185.9	144.8	200.6	104.3	161.4	161.4	178.3	141.6	191.6	101.1	156.1	156.1	170.1	138.1	182.0	97.2
	85	176.8	176.8	183.9	172.3	200.6	135.5	171.3	171.3	176.3	168.8	191.6	132.1	165.2	165.2	168.0	165.0	181.7	128.5
	90	186.4	186.4	186.6	186.6	200.0	165.0	179.9	179.9	180.0	180.0	191.1	156.9	172.3	172.3	172.4	172.4	180.8	157.7
7000	75	166.6	156.2	189.0	118.5	201.7	72.7	160.3	153.0	181.0	115.1	191.9	69.2	153.5	149.6	172.5	111.5	181.4	65.6
	80	171.1	171.1	188.1	153.2	203.0	108.5	165.9	165.9	180.2	148.7	193.9	104.8	160.2	160.2	171.8	143.5	183.9	101.1
	85	181.7	181.7	185.2	182.1	202.6	143.1	175.7	175.7	177.2	177.2	193.2	139.6	168.8	168.8	168.9	168.9	183.0	135.9
	90	190.8	190.8	190.9	190.9	201.1	174.8	183.4	183.4	183.5	183.5	191.6	171.0	175.5	175.5	175.6	175.6	181.3	167.0
7700	75	167.8	163.8	190.9	123.4	203.3	74.0	161.3	160.5	182.6	120.0	202.0	73.4	154.3	154.3	173.8	116.3	182.5	66.8
	80	175.2	175.2	189.8	155.5	204.9	112.5	169.7	169.7	181.0	155.3	195.3	108.9	163.5	163.5	172.1	151.3	185.0	105.1
	85	185.7	185.7	185.8	185.8	204.2	150.5	179.1	179.1	179.2	179.2	194.5	147.0	171.6	171.6	171.7	171.7	184.1	143.2
	90	194.0	194.0	194.1	194.1	201.7	184.0	186.4	186.4	186.5	186.5	191.9	180.2	178.4	178.4	178.5	178.5	181.3	176.1
8400	75	168.5	168.5	192.3	128.2	204.6	75.3	162.1	162.1	183.9	124.7	204.3	75.0	156.4	156.4	174.8	121.0	183.5	68.2
	80	178.8	178.8	190.0	165.8	206.4	116.5	172.8	172.8	181.4	162.1	196.5	112.9	166.2	166.2	172.3	158.0	185.9	109.0
	85	188.9	188.9	189.0	189.0	205.4	157.9	181.8	181.8	181.8	181.8	195.6	153.3	173.6	173.6	173.7	173.7	184.9	144.8
	90	196.8	196.8	196.9	196.9	201.9	193.0	189.3	189.3	189.4	189.4	191.9	189.1	180.6	180.6	180.6	180.6	181.2	181.2

Notes:

1. All capacities shown are gross and have not considered indoor fan heat. To obtain **NET** cooling capacity subtract indoor fan heat. For indoor fan heat formula, refer to appropriate airflow table notes.
2. MBh = Total Gross Capacity
3. SHC = Sensible Heat Capacity



Performance Data

Table 5. Gross cooling capacities 20 tons - E/GBC240A3,4,W,K

Air Flow cfm	Ent DB (°F)	Ambient Temperature																	
		85						95						105					
		Entering Wet Bulb																	
		61		67		73		61		67		73		61		67		73	
MBh	SHC	MBh	SHC	MBh	SHC	MBh	SHC	MBh	SHC	MBh	SHC	MBh	SHC	MBh	SHC	MBh	SHC		
6400	75	231.8	181.2	262.2	145.9	288.6	100.1	220.1	175.0	248.1	139.4	270.5	93.6	207.4	168.4	232.6	132.4	251.6	90.5
	80	229.5	203.7	261.5	176.3	288.7	137.2	217.6	201.1	247.8	169.7	270.9	130.0	204.9	193.9	232.4	162.6	251.5	122.3
	85	226.8	226.8	260.1	206.3	288.8	168.9	218.1	218.1	246.3	199.8	271.3	161.8	208.5	208.5	231.2	192.8	251.9	154.0
	90	239.8	239.8	257.7	232.5	288.6	199.1	230.7	230.7	244.0	225.3	271.2	191.8	220.3	220.3	228.9	217.6	251.7	183.9
7200	75	237.4	191.6	268.5	152.6	293.6	107.1	224.9	185.2	253.4	145.7	274.7	99.6	211.4	178.3	236.7	138.4	255.4	92.1
	80	233.6	219.4	267.9	186.0	294.0	142.6	221.3	212.4	252.8	179.0	275.0	135.0	207.9	205.0	236.3	171.5	255.7	127.5
	85	236.0	236.0	265.6	219.2	294.3	177.2	226.6	226.6	250.9	212.4	275.7	169.3	216.1	216.1	234.8	200.6	255.6	161.2
	90	249.6	249.6	262.0	246.2	293.6	210.9	239.5	239.5	247.4	238.8	275.1	203.4	228.0	228.0	231.3	231.3	254.7	195.2
8000	75	241.7	201.6	273.5	158.9	297.8	108.8	228.6	194.9	257.4	151.7	279.0	101.4	214.4	184.0	239.9	144.1	258.4	93.5
	80	236.7	230.2	272.5	195.1	298.2	147.7	223.7	223.1	256.6	187.9	278.8	140.1	209.8	209.8	239.2	180.0	258.9	132.5
	85	243.9	243.9	269.8	227.9	298.7	185.1	233.8	233.8	253.7	220.9	279.0	177.1	222.4	222.4	236.4	212.4	258.9	169.1
	90	258.0	258.0	264.8	259.3	297.6	222.4	247.0	247.0	249.4	249.4	278.2	214.6	234.3	234.3	234.5	234.5	257.3	206.4
8800	75	245.0	207.9	277.4	164.6	302.2	110.6	231.9	197.4	260.7	156.3	282.3	102.9	215.6	193.0	242.6	148.2	266.8	96.9
	80	238.7	238.7	276.1	203.9	301.8	152.8	226.2	226.2	259.5	196.4	282.3	145.3	214.9	214.9	241.5	188.4	261.4	137.4
	85	250.9	250.9	271.8	238.8	302.1	192.9	240.1	240.1	255.4	230.7	281.7	184.8	227.7	227.7	237.4	222.0	261.2	176.6
	90	265.3	265.3	266.5	266.5	300.7	233.7	253.4	253.4	253.5	253.5	280.6	225.7	239.5	239.5	239.6	239.6	260.1	209.1
9600	75	246.5	216.3	280.9	169.3	305.7	112.3	232.1	208.5	263.7	161.5	285.0	104.4	216.6	200.2	244.8	153.1	270.4	98.7
	80	242.1	242.1	278.9	212.4	305.1	157.8	231.4	231.4	261.8	204.7	285.0	149.4	219.5	219.5	243.2	196.5	263.6	140.5
	85	257.1	257.1	273.4	248.4	304.7	200.5	245.5	245.5	256.4	240.1	284.1	192.4	232.2	232.2	237.9	231.3	262.9	184.1
	90	271.6	271.6	271.8	271.8	303.7	242.6	258.8	258.8	258.9	258.9	281.6	232.4	243.7	243.7	243.8	243.8	259.6	223.0

Air Flow cfm	Ent DB (°F)	Ambient Temperature																	
		115						120						125					
		Entering Wet Bulb																	
		61		67		73		61		67		73		61		67		73	
MBh	SHC	MBh	SHC	MBh	SHC	MBh	SHC	MBh	SHC	MBh	SHC	MBh	SHC	MBh	SHC	MBh	SHC		
6400	75	193.5	161.3	215.2	124.7	231.1	82.6	186.0	157.5	205.6	120.5	227.3	81.0	178.0	153.5	195.3	116.1	218.5	77.6
	80	191.2	186.3	215.2	154.7	231.6	114.5	183.7	182.3	205.6	150.4	220.5	110.3	175.7	175.7	195.4	145.9	208.5	105.8
	85	197.6	197.6	214.3	184.0	232.0	145.1	191.4	191.4	205.0	176.8	221.1	140.8	184.5	184.5	194.5	173.7	209.3	136.1
	90	208.2	208.2	211.9	209.2	231.5	175.7	201.2	201.2	202.6	202.6	220.7	171.4	193.0	193.0	193.2	193.2	214.8	169.0
7200	75	196.8	169.7	218.3	130.4	241.0	86.4	188.8	163.4	208.3	126.0	221.7	79.4	180.7	156.3	197.6	120.5	208.7	74.6
	80	193.4	193.4	218.0	163.3	234.5	119.4	186.5	186.5	207.9	158.8	222.9	115.1	179.8	179.8	197.1	154.1	220.9	114.2
	85	204.0	204.0	216.3	193.4	234.9	152.9	197.1	197.1	206.2	188.6	229.2	150.5	189.3	189.3	195.3	183.4	210.8	143.5
	90	214.4	214.4	214.5	214.5	234.1	187.0	206.3	206.3	206.4	206.4	227.4	184.2	197.0	197.0	197.1	197.1	218.3	180.1
8000	75	198.3	177.0	220.7	134.6	245.4	88.3	189.8	172.5	210.2	130.0	236.2	84.7	180.8	167.7	199.0	125.1	209.7	75.6
	80	197.9	197.9	220.1	171.6	242.7	126.3	191.2	191.2	209.6	167.0	233.3	122.7	183.8	183.8	198.3	162.2	223.3	119.0
	85	209.2	209.2	217.3	203.2	236.9	160.4	201.5	201.5	206.8	198.2	232.6	158.5	192.9	192.9	195.4	192.9	223.0	154.8
	90	219.1	219.1	219.2	219.2	236.1	192.5	210.0	210.0	210.1	210.1	229.4	192.0	200.8	200.8	200.9	200.9	219.7	188.3
8800	75	199.3	184.3	222.6	139.4	249.0	90.1	190.6	179.7	211.7	134.6	239.5	86.4	181.2	174.9	200.0	129.5	210.4	76.6
	80	202.2	202.2	221.6	179.7	244.8	130.2	195.0	195.0	210.8	173.7	226.7	122.7	187.0	187.0	199.0	165.9	213.6	117.6
	85	213.4	213.4	217.6	212.6	238.3	171.4	205.0	205.0	206.8	206.1	235.1	166.3	195.5	195.5	195.6	195.6	225.3	162.4
	90	222.7	222.7	222.8	222.8	236.1	204.3	213.6	213.6	213.7	213.7	230.7	201.9	203.9	203.9	204.0	204.0	221.0	197.8
9600	75	199.8	191.4	223.9	143.9	251.9	91.8	190.8	186.7	212.6	139.0	242.1	88.0	181.1	181.1	200.7	133.9	211.1	77.6
	80	205.9	205.9	222.7	182.1	247.0	133.8	198.2	198.2	210.6	179.6	227.7	126.4	189.5	189.5	198.5	174.0	227.4	125.8
	85	216.7	216.7	217.5	217.5	246.5	177.5	207.7	207.7	207.7	207.7	237.0	173.8	197.6	197.6	197.7	197.7	226.9	169.8
	90	225.8	225.8	225.8	225.8	241.1	215.1	216.7	216.7	216.8	216.8	231.6	211.1	211.4	211.4	211.6	211.6	221.7	207.0

- Notes:**
1. All capacities shown are gross and have not considered indoor fan heat. To obtain **NET** cooling capacity subtract indoor fan heat. For indoor fan heat formula, refer to appropriate airflow table notes.
 2. MBh = Total Gross Capacity
 3. SHC = Sensible Heat Capacity

Table 6. Gross cooling capacities 25 tons - E/GBC300A3,4,W,K

Air Flow cfm	Ent DB (°F)	Ambient Temperature																	
		85						95						105					
		Entering Wet Bulb																	
		61		67		73		61		67		73		61		67		73	
MBh	SHC	MBh	SHC	MBh	SHC	MBh	SHC	MBh	SHC	MBh	SHC	MBh	SHC	MBh	SHC	MBh	SHC		
7000	75	253.7	194.1	287.3	158.0	318.8	112.4	241.0	187.4	272.6	151.0	300.3	104.1	227.3	180.2	256.6	143.6	279.5	101.0
	80	249.6	222.6	286.4	189.8	318.9	149.8	237.3	212.0	271.8	182.4	300.5	142.1	223.1	206.3	256.1	174.9	279.8	133.8
	85	244.7	244.7	285.0	220.3	318.6	182.3	232.6	232.6	270.3	213.3	300.4	174.8	222.9	222.9	254.3	205.7	280.2	166.5
	90	255.4	255.4	281.4	247.3	318.4	213.8	246.1	246.1	267.1	235.2	300.5	206.1	235.9	235.9	250.6	231.4	280.2	197.6
8000	75	260.7	206.2	296.0	166.0	326.3	113.0	247.1	199.1	280.0	158.6	305.9	111.2	232.4	191.5	262.5	150.7	283.0	102.2
	80	254.5	234.5	295.4	201.1	326.4	156.2	241.1	226.8	279.7	193.6	306.2	148.0	226.7	218.6	262.2	185.5	283.8	139.2
	85	252.6	252.6	292.0	235.2	326.2	192.8	243.0	243.0	276.2	227.8	306.4	183.9	232.4	232.4	259.1	219.9	284.5	175.0
	90	267.3	267.3	286.2	262.9	325.7	227.5	257.2	257.2	270.6	254.8	305.8	219.3	245.9	245.9	253.8	246.1	284.0	210.4
9000	75	265.9	217.5	302.8	173.3	331.7	121.4	251.4	210.1	285.6	165.6	309.7	112.7	236.0	202.2	266.9	157.3	285.4	103.2
	80	257.8	246.5	302.0	211.8	332.0	162.1	243.7	238.5	284.6	203.7	310.4	153.5	228.4	228.4	265.9	195.2	286.5	144.4
	85	262.2	262.2	297.0	249.2	332.0	201.6	251.8	251.8	280.3	238.3	310.9	192.9	240.3	240.3	261.1	229.1	287.4	183.4
	90	277.6	277.6	289.3	277.3	330.5	240.5	266.6	266.6	272.9	269.0	309.6	232.0	254.2	254.2	255.2	255.2	286.6	222.8
10000	75	269.6	228.1	308.1	180.2	335.9	123.0	254.5	218.1	289.7	171.3	312.4	113.9	237.0	208.7	270.4	162.6	288.4	104.7
	80	259.6	257.7	306.3	221.6	336.4	167.8	244.6	244.6	288.1	213.3	313.6	158.9	232.6	232.6	268.5	204.6	288.9	149.5
	85	270.6	270.6	299.0	258.1	336.8	210.6	259.5	259.5	281.3	249.1	314.1	201.4	247.1	247.1	262.2	239.6	289.3	191.6
	90	286.5	286.5	290.7	290.7	334.1	253.1	274.6	274.6	274.8	274.8	312.3	244.4	261.1	261.1	261.2	261.2	288.5	233.4
11000	75	271.5	233.3	312.5	185.9	339.0	124.5	254.7	225.8	293.7	177.3	314.8	115.2	237.8	216.5	273.3	168.2	290.5	106.0
	80	261.5	261.5	309.5	231.1	339.9	173.2	250.3	250.3	290.6	222.6	316.3	164.2	238.1	238.1	270.4	213.7	291.0	154.7
	85	277.9	277.9	300.4	268.6	339.8	219.1	266.1	266.1	282.0	259.4	316.2	209.7	252.9	252.9	262.3	249.8	290.7	199.7
	90	294.3	294.3	294.5	294.5	336.8	265.4	281.5	281.5	281.6	281.6	314.3	250.4	266.8	266.8	267.0	267.0	288.2	242.1

Air Flow cfm	Ent DB (°F)	Ambient Temperature																	
		115						120						125					
		Entering Wet Bulb																	
		61		67		73		61		67		73		61		67		73	
MBh	SHC	MBh	SHC	MBh	SHC	MBh	SHC	MBh	SHC	MBh	SHC	MBh	SHC	MBh	SHC	MBh	SHC		
7000	75	212.4	172.5	238.7	135.5	255.6	91.5	204.4	168.4	228.8	131.1	242.8	86.6	195.9	164.2	218.1	126.5	230.1	81.7
	80	208.5	197.9	238.6	166.7	256.3	124.5	200.6	193.5	228.9	162.3	243.4	119.5	192.3	188.9	218.1	157.5	230.7	114.7
	85	212.1	212.1	236.7	197.6	257.3	157.0	206.1	206.1	227.1	193.2	244.6	151.6	199.5	199.5	216.7	187.7	231.1	146.3
	90	224.3	224.3	233.3	222.4	257.3	188.3	217.8	217.8	223.8	217.7	244.5	183.2	210.5	210.5	213.6	212.6	230.9	177.8
8000	75	216.6	183.5	243.1	142.2	258.5	92.7	208.0	179.3	232.5	137.5	245.6	87.8	199.0	172.6	221.0	132.7	237.2	84.6
	80	211.1	210.0	242.7	176.7	258.8	129.6	202.8	202.8	232.1	171.9	246.3	124.9	194.8	194.8	220.7	166.9	232.8	119.9
	85	220.5	220.5	240.4	208.0	259.7	165.1	213.8	213.8	229.2	203.1	246.5	159.8	206.5	206.5	218.0	197.6	233.4	154.7
	90	233.0	233.0	235.3	235.3	259.6	200.7	225.5	225.5	225.6	225.6	246.2	195.5	217.1	217.1	217.2	217.2	232.4	190.2
9000	75	219.3	189.2	246.3	147.5	260.8	93.9	209.3	186.2	235.1	142.6	247.1	88.8	199.7	181.0	223.1	137.3	242.1	86.7
	80	214.1	214.1	245.4	186.1	261.9	134.0	207.5	207.5	234.2	181.2	248.5	130.1	200.3	200.3	222.3	176.0	234.5	124.6
	85	227.4	227.4	241.0	219.1	261.5	173.3	220.0	220.0	230.1	213.8	248.6	168.2	211.9	211.9	218.4	208.2	234.5	162.8
	90	239.8	239.8	239.9	239.9	261.1	212.9	231.4	231.4	231.5	231.5	247.4	202.1	221.8	221.8	221.9	221.9	233.3	198.0
10000	75	219.4	199.1	248.9	153.0	262.4	95.0	210.0	194.1	237.1	147.8	248.1	89.8	200.0	188.8	224.5	142.4	246.0	88.7
	80	219.7	219.7	247.2	195.2	263.7	140.0	212.6	212.6	235.6	190.2	250.2	133.9	204.8	204.8	223.3	184.0	235.7	128.3
	85	233.0	233.0	241.4	229.5	263.7	180.6	225.0	225.0	230.1	224.1	249.8	176.4	216.0	216.0	218.1	218.1	235.2	170.9
	90	245.2	245.2	245.3	245.3	261.1	220.6	235.8	235.8	235.9	235.9	246.8	214.5	225.0	225.0	225.0	225.0	232.7	208.6
11000	75	219.6	206.8	250.8	158.2	263.5	96.1	209.9	201.6	238.4	152.9	260.5	94.7	199.7	196.3	225.2	147.2	249.0	90.4
	80	224.4	224.4	248.4	202.4	265.3	143.5	216.8	216.8	236.0	194.6	251.3	138.0	208.4	208.4	222.6	190.0	243.9	135.0
	85	237.7	237.7	241.0	239.6	264.5	189.7	229.0	229.0	229.5	229.5	250.5	184.4	219.2	219.2	219.3	219.3	235.6	178.8
	90	249.4	249.4	249.5	249.5	260.6	230.3	239.0	239.0	239.0	239.0	246.2	224.3	226.9	226.9	226.9	226.9	232.0	218.4

Notes:

1. All capacities shown are gross and have not considered indoor fan heat. To obtain **NET** cooling capacity subtract indoor fan heat. For indoor fan heat formula, refer to appropriate airflow table notes.
2. MBh = Total Gross Capacity
3. SHC = Sensible Heat Capacity



Performance Data

Table 7. Evaporator fan performance - 15 ton units with gas heat - GBC180 - downflow airflow

External Static Pressure (Inches of Water)																					
		0.10		0.20		0.30		0.40		0.50		0.60		0.70		0.80		0.90		1.00	
cfm	rpm	bhp	rpm	bhp	rpm	bhp	rpm	bhp	rpm	bhp	rpm	bhp	rpm	bhp	rpm	bhp	rpm	bhp	rpm	bhp	
3-hp Standard Motor & Low Static Drive Accessory										3-hp Standard Motor Drive											
4800	483	0.69	525	0.81	562	0.92	602	1.05	638	1.17	671	1.30	703	1.43	732	1.56	760	1.68	787	1.81	
5400	532	0.94	572	1.08	607	1.21	640	1.34	675	1.49	707	1.63	738	1.76	767	1.91	794	2.05	820	2.20	
6000	581	1.26	619	1.41	653	1.56	683	1.71	713	1.85	744	2.01	774	2.17	802	2.32	829	2.48	855	2.64	
6600	632	1.63	667	1.81	699	1.98	728	2.14	756	2.30	782	2.45	812	2.63	839	2.80	865	2.98	890 ^(a)	3.14	
7200	683	2.08	716	2.28	747	2.46	774	2.64	801	2.82	826	2.99	850	3.16	877	3.35	902	3.54	927	3.73	
																	5-hp Oversized Motor & Drive				

Continued

External Static Pressure (Inches of Water)																					
		1.10		1.20		1.30		1.40		1.50		1.60		1.70		1.80		1.90		2.00	
cfm	rpm	bhp	rpm	bhp	rpm	bhp	rpm	bhp	rpm	bhp	rpm	bhp	rpm	bhp	rpm	bhp	rpm	bhp	rpm	bhp	
3-hp Standard Motor & Drive							3-hp Standard Motor & High Static Drive Accessory							5-hp Oversized Motor & Drive							
4800	812	1.93	838	2.09	864	2.25	889	2.41	912	2.57	936	2.74	958	2.90	980	3.07	1001	3.24	1022	3.41	
5400	845	2.34	870	2.48	893	2.62	915	2.76	939	2.94	962	3.12	984	3.30	1006	3.48	1027	3.67	1047	3.85	
6000	880	2.80	903	2.96	926	3.12	949	3.28	970	3.43	991	3.59	1011	3.75	1032	3.93	1053	4.13	1074	4.33	
6600	915	3.31	938	3.49	961	3.67	983	3.85	1004	4.02	1025	4.20	1045	4.37	1064	4.55	1083	4.72	1102	4.89	
7200	951	3.92	974	4.10	996	4.29	1017	4.48	1038	4.68	1059	4.87	1079	5.06	1098	5.25	1117	5.44	---	---	

Notes:

1. For Standard Evaporator Fan Speed (rpm), reference [Table 27, p. 42](#).
2. For High Evaporator Fan Speed (rpm), reference [Table 29, p. 42](#).
3. For Oversized Evaporator Fan Speed (rpm), reference [Table 30, p. 42](#).
4. Fan motor heat (MBh) = 3.15 x Fan bhp.
5. Data includes pressure drop due to standard filters and wet coils. No accessories or options are included in pressure drop data.
6. For all non-standard sheave combinations, please refer to accessory installer's guides ACC-SVN163*-EN and ACC-SVN169*-EN.
7. Factory supplied motors, in commercial equipment, are definite purpose motors, specifically designed and tested to operate reliably and continuously at all cataloged conditions. Using the full horsepower range of our fan motors as shown in our tabular data will not result in nuisance tripping or premature motor failure. Our product's warranty will not be affected.

(a) 3-hp Standard Motor & High Static Drive Accessory

Table 8. Evaporator fan performance - 15 ton unit with gas heat - GBC180 - horizontal airflow

External Static Pressure (Inches of Water)																					
		0.10		0.20		0.30		0.40		0.50		0.60		0.70		0.80		0.90		1.00	
cfm	rpm	bhp	rpm	bhp	rpm	bhp	rpm	bhp	rpm	bhp	rpm	bhp	rpm	bhp	rpm	bhp	rpm	bhp	rpm	bhp	
3-hp Standard Motor & Low Static Drive Accessory										3-hp Standard Motor Drive											
4800	488	0.72	532	0.85	572	0.99	609	1.12	643	1.24	675	1.37	707	1.52	738	1.67	767	1.82	796	1.98	
5400	539	1.00	578	1.13	615	1.29	650	1.43	683	1.58	714	1.72	743	1.87	771	2.02	800	2.19	827	2.36	
6000	591	1.34	626	1.48	660	1.65	693	1.82	724	1.98	754	2.14	782	2.30	809	2.46	834	2.62	860	2.79	
6600	643	1.75	675	1.90	706	2.07	738	2.26	767	2.45	795	2.62	823	2.80	849	2.98	873	3.15	897 ^(a)	3.33	
7200	696	2.24	725	2.40	754	2.58	783	2.77	811	2.99	838	3.19	864	3.38	889	3.57	913	3.76	937	3.95	
										5-hp Oversized Motor & Drive											

Continued

External Static Pressure (Inches of Water)																					
		1.10		1.20		1.30		1.40		1.50		1.60		1.70		1.80		1.90		2.00	
cfm	rpm	bhp	rpm	bhp	rpm	bhp	rpm	bhp	rpm	bhp	rpm	bhp	rpm	bhp	rpm	bhp	rpm	bhp	rpm	bhp	
3-hp Standard Motor & Drive							3-hp Standard Motor & High Static Drive Accessory							5-hp Oversized Motor & Drive							
4800	823	2.13	849	2.29	874	2.44	899	2.60	923	2.76	946	2.91	969	3.07	991	3.23	1012	3.39	1033	3.55	
5400	853	2.53	879	2.70	903	2.88	927	3.05	951	3.22	973	3.40	995	3.57	1017	3.75	1038	3.93	1059	4.11	
6000	886	2.98	910	3.17	934	3.36	957	3.55	980	3.74	1003	3.94	1024	4.13	1045	4.32	1066	4.52	1086	4.71	
6600	920	3.50	944	3.70	967	3.91	990	4.11	1012	4.32	1033	4.53	1054	4.74	1075	4.95	1096	5.16	1116	5.38	
7200	959	4.15	981	4.34	1002	4.53	1024	4.74	1045	4.96	1066	5.19	1087	5.42	1107	5.65	---	---	---	---	

Notes:

1. For Standard Evaporator Fan Speed (rpm), reference [Table 27, p. 42](#).
2. For High Evaporator Fan Speed (rpm), reference [Table 29, p. 42](#).
3. For Oversized Evaporator Fan Speed (rpm), reference [Table 30, p. 42](#).
4. Fan motor heat (MBh) = 3.15 x Fan bhp.
5. Data includes pressure drop due to standard filters and wet coils. No accessories or options are included in pressure drop data.
6. For all non-standard sheave combinations, please refer to accessory installer's guides ACC-SVN163*-EN and ACC-SVN169*-EN.
7. Factory supplied motors, in commercial equipment, are definite purpose motors, specifically designed and tested to operate reliably and continuously at all cataloged conditions. Using the full horsepower range of our fan motors as shown in our tabular data will not result in nuisance tripping or premature motor failure. Our product's warranty will not be affected.

(a) 3HP Standard Motor & High Static Drive Accessory



Performance Data

Table 9. Evaporator fan performance - 15 ton cooling only units (model number digit 8 = 3, 4, W) - EBC180 - downflow airflow

External Static Pressure (Inches of Water)																					
		0.10		0.20		0.30		0.40		0.50		0.60		0.70		0.80		0.90		1.00	
cfm	rpm	bhp	rpm	bhp	rpm	bhp	rpm	bhp	rpm	bhp	rpm	bhp	rpm	bhp	rpm	bhp	rpm	bhp	rpm	bhp	
3-hp Standard Motor & Low Static Drive Accessory											3-hp Standard Motor Drive										
4800	---	---	---	---	489	0.68	530	0.78	568	0.89	608	1.00	644	1.11	679	1.24	713	1.39	746	1.53	
5400	---	---	---	---	517	0.86	558	0.99	594	1.11	628	1.23	663	1.35	697	1.48	729	1.60	760	1.75	
6000	---	---	500	0.93	546	1.08	586	1.23	622	1.37	655	1.50	685	1.63	717	1.76	748	1.91	778	2.05	
6600	480	0.98	530	1.17	575	1.34	614	1.50	650	1.66	683	1.81	713	1.96	741	2.10	768	2.24	798	2.40	
7200	514	1.24	562	1.44	604	1.63	643	1.82	679	1.99	711	2.16	741	2.33	769	2.49	795	2.65	821	2.80	

Continued

External Static Pressure (Inches of Water)																					
		1.10		1.20		1.30		1.40		1.50		1.60		1.70		1.80		1.90		2.00	
cfm	rpm	bhp	rpm	bhp	rpm	bhp	rpm	bhp	rpm	bhp	rpm	bhp	rpm	bhp	rpm	bhp	rpm	bhp	rpm	bhp	
3-hp Standard Motor & Drive											3-hp Standard Motor & High Static Drive Accessory										
4800	777	1.68	806	1.82	832	1.97	858	2.12	882	2.26	906	2.41	928	2.56	951	2.72	972	2.87	994	3.02	
5400	791	1.91	820	2.07	849	2.24	876	2.40	902	2.57	926	2.73	949	2.89	971	3.06	993	3.23	1014	3.39	
6000	806	2.18	835	2.34	863	2.52	890	2.70	916	2.88	942	3.06	966	3.24	990	3.43	1013	3.61	1034	3.79	
6600	826	2.55	853	2.71	879	2.86	905	3.01	931	3.20	956	3.40	981	3.6	1004	3.80	1028	4.00	1050	4.20	
7200	846	2.96	873	3.13	899	3.30	924	3.47	948	3.63	972	3.79	995	3.98	1019	4.19	1042	4.41	1065	4.62	
											5-hp Oversized Motor & Drive										

Notes:

1. For Standard Evaporator Fan Speed (rpm), reference [Table 27, p. 42](#).
2. For High Evaporator Fan Speed (rpm), reference [Table 29, p. 42](#).
3. For Oversized Evaporator Fan Speed (rpm), reference [Table 30, p. 42](#).
4. Fan motor heat (MBh) = 3.15 x Fan bhp.
5. Data includes pressure drop due to standard filters and wet coils. No accessories or options are included in pressure drop data.
6. For all non-standard sheave combinations, please refer to accessory installer's guides ACC-SVN163*-EN and ACC-SVN169*-EN.
7. Factory supplied motors, in commercial equipment, are definite purpose motors, specifically designed and tested to operate reliably and continuously at all cataloged conditions. Using the full horsepower range of our fan motors as shown in our tabular data will not result in nuisance tripping or premature motor failure. Our product's warranty will not be affected.

Table 10. Evaporator fan performance - 15 ton cooling only units (model number digit 8 = 3, 4, W) - EBC180 - horizontal airflow

External Static Pressure (Inches of Water)																					
		0.10		0.20		0.30		0.40		0.50		0.60		0.70		0.80		0.90		1.00	
cfm	rpm	bhp	rpm	bhp	rpm	bhp	rpm	bhp	rpm	bhp	rpm	bhp	rpm	bhp	rpm	bhp	rpm	bhp	rpm	bhp	
3-hp Standard Motor & Low Static Drive Accessory											3-hp Standard Motor Drive										
4800	---	---	475	0.66	517	0.77	563	0.92	605	1.07	644	1.21	680	1.35	714	1.51	745	1.66	775	1.81	
5400	---	---	512	0.87	552	1.00	589	1.13	631	1.30	669	1.46	705	1.63	738	1.79	770	1.95	799	2.12	
6000	498	0.94	548	1.12	589	1.28	624	1.42	657	1.56	695	1.75	730	1.93	763	2.12	794	2.30	824	2.48	
6600	536	1.21	585	1.41	626	1.60	660	1.76	691	1.91	721	2.06	755	2.27	788	2.48	819	2.68	848	2.88	
7200	575	1.52	623	1.75	662	1.96	697	2.15	727	2.32	755	2.49	782	2.65	814	2.87	844	3.10	873	3.32	

Continued

External Static Pressure (Inches of Water)																					
		1.10		1.20		1.30		1.40		1.50		1.60		1.70		1.80		1.90		2.00	
cfm	rpm	bhp	rpm	bhp	rpm	bhp	rpm	bhp	rpm	bhp	rpm	bhp	rpm	bhp	rpm	bhp	rpm	bhp	rpm	bhp	
3-hp Standard Motor & Drive							3-hp Standard Motor & High Static Drive Accessory														
4800	804	1.96	831	2.12	858	2.27	883	2.42	907	2.58	931	2.74	953	2.92	975	3.09	996	3.27	1017	3.45	
5400	828	2.29	855	2.47	881	2.64	906	2.81	931	2.98	954	3.15	977	3.33	1000	3.50	1021	3.67	1042	3.86	
6000	852	2.66	879	2.85	905	3.04	930	3.23	954	3.42	978	3.61	1001	3.80	1023	3.99	1044	4.18	1066	4.37	
6600	877	3.08	904	3.28	930	3.47	954	3.68	979	3.89	1002	4.10	1025	4.31	1047	4.52	1068	4.73	1089	4.94	
7200	901	3.54	928	3.76	954	3.98	979	4.19	1003	4.41	1026	4.63	1049	4.86	1071	5.08	1092	5.31	1113	5.54	

5-hp Oversized Motor & Drive

Notes:

1. For Standard Evaporator Fan Speed (rpm), reference [Table 27, p. 42](#).
2. For High Evaporator Fan Speed (rpm), reference [Table 29, p. 42](#).
3. For Oversized Evaporator Fan Speed (rpm), reference [Table 30, p. 42](#).
4. Fan motor heat (MBh) = 3.15 x Fan bhp.
5. Data includes pressure drop due to standard filters and wet coils. No accessories or options are included in pressure drop data.
6. For all non-standard sheave combinations, please refer to accessory installer's guides ACC-SVN163*-EN and ACC-SVN169*-EN.
7. Factory supplied motors, in commercial equipment, are definite purpose motors, specifically designed and tested to operate reliably and continuously at all cataloged conditions. Using the full horsepower range of our fan motors as shown in our tabular data will not result in nuisance tripping or premature motor failure. Our product's warranty will not be affected.



Performance Data

Table 11. Evaporator fan performance - 15 ton cooling only units (model number digit 8 = K) - EBC180 - downflow airflow

External Static Pressure (Inches of Water)																					
		0.10		0.20		0.30		0.40		0.50		0.60		0.70		0.80		0.90		1.00	
cfm	rpm	bhp	rpm	bhp	rpm	bhp	rpm	bhp	rpm	bhp	rpm	bhp	rpm	bhp	rpm	bhp	rpm	bhp	rpm	bhp	
5-hp Standard Motor & Low Static Drive Accessory											5-hp Standard Motor & Drive										
4800	---	---	---	---	---	---	530	0.78	568	0.89	608	1.00	644	1.11	679	1.24	713	1.39	746	1.53	
5400	---	---	---	---	517	0.86	558	0.99	594	1.11	628	1.23	663	1.35	697	1.48	729	1.60	760	1.75	
6000	---	---	---	---	546	1.08	586	1.23	622	1.37	655	1.50	685	1.63	717	1.76	748	1.91	778	2.05	
6600	---	---	530	1.17	575	1.34	614	1.50	650	1.66	683	1.81	713	1.96	741	2.10	768	2.24	798	2.40	
7200	514	1.24	562	1.44	604	1.63	643	1.82	679	1.99	711	2.16	741	2.33	769	2.49	795	2.65	821	2.80	

Continued

External Static Pressure (Inches of Water)																					
		1.10		1.20		1.30		1.40		1.50		1.60		1.70		1.80		1.90		2.00	
cfm	rpm	bhp	rpm	bhp	rpm	bhp	rpm	bhp	rpm	bhp	rpm	bhp	rpm	bhp	rpm	bhp	rpm	bhp	rpm	bhp	
5-hp Standard Motor & Drive											5-hp Standard Motor & High Static Drive Accessory										
4800	777	1.68	806	1.82	832	1.97	858	2.12	882	2.26	906	2.41	928	2.56	951	2.72	972	2.87	994	3.02	
5400	791	1.91	820	2.07	849	2.24	876	2.40	902	2.57	926	2.73	949	2.89	971	3.06	993	3.23	1014	3.39	
6000	806	2.18	835	2.34	863	2.52	890	2.70	916	2.88	942	3.06	966	3.24	990	3.43	1013	3.61	1034	3.79	
6600	826	2.55	853	2.71	879	2.86	905	3.01	931	3.20	956	3.40	981	3.6	1004	3.80	1028	4.00	1050	4.20	
7200	846	2.96	873	3.13	899	3.30	924	3.47	948	3.63	972	3.79	995	3.98	1019	4.19	1042	4.41	1065	4.62	

Notes:

1. For Standard Evaporator Fan Speed (rpm), reference [Table 27, p. 42](#).
2. For High Evaporator Fan Speed (rpm), reference [Table 29, p. 42](#).
3. Fan motor heat (MBh) = 3.15 x Fan bhp.
4. Data includes pressure drop due to standard filters and wet coils. No accessories or options are included in pressure drop data.
5. For all non-standard sheave combinations, please refer to accessory installer's guides ACC-SVN163*-EN and ACC-SVN169*-EN.
6. Factory supplied motors, in commercial equipment, are definite purpose motors, specifically designed and tested to operate reliably and continuously at all cataloged conditions. Using the full horsepower range of our fan motors as shown in our tabular data will not result in nuisance tripping or premature motor failure. Our product's warranty will not be affected.

Table 12. Evaporator fan performance - 15 ton cooling only units (model number digit 8 = K) - EBC180 - horizontal airflow

External Static Pressure (Inches of Water)																					
		0.10		0.20		0.30		0.40		0.50		0.60		0.70		0.80		0.90		1.00	
cfm	rpm	bhp	rpm	bhp	rpm	bhp	rpm	bhp	rpm	bhp	rpm	bhp	rpm	bhp	rpm	bhp	rpm	bhp	rpm	bhp	
5-hp Standard Motor & Low Static Drive Accessory											5-hp Standard Motor & Drive										
4800	---	---	---	---	517	0.77	563	0.92	605	1.07	644	1.21	680	1.35	714	1.51	745	1.66	775	1.81	
5400	---	---	512	0.87	552	1.00	589	1.13	631	1.30	669	1.46	705	1.63	738	1.79	770	1.95	799	2.12	
6000	---	---	548	1.12	589	1.28	624	1.42	657	1.56	695	1.75	730	1.93	763	2.12	794	2.30	824	2.48	
6600	536	1.21	585	1.41	626	1.60	660	1.76	691	1.91	721	2.06	755	2.27	788	2.48	819	2.68	848	2.88	
7200	575	1.52	623	1.75	662	1.96	697	2.15	727	2.32	755	2.49	782	2.65	814	2.87	844	3.10	873	3.32	

Continued

External Static Pressure (Inches of Water)																					
		1.10		1.20		1.30		1.40		1.50		1.60		1.70		1.80		1.90		2.00	
cfm	rpm	bhp	rpm	bhp	rpm	bhp	rpm	bhp	rpm	bhp	rpm	bhp	rpm	bhp	rpm	bhp	rpm	bhp	rpm	bhp	
5-hp Standard Motor & Drive										5-hp Standard Motor & High Static Drive Accessory											
4800	804	1.96	831	2.12	858	2.27	883	2.42	907	2.58	931	2.74	953	2.92	975	3.09	996	3.27	1017	3.45	
5400	828	2.29	855	2.47	881	2.64	906	2.81	931	2.98	954	3.15	977	3.33	1000	3.50	1021	3.67	1042	3.86	
6000	852	2.66	879	2.85	905	3.04	930	3.23	954	3.42	978	3.61	1001	3.80	1023	3.99	1044	4.18	1066	4.37	
6600	877	3.08	904	3.28	930	3.47	954	3.68	979	3.89	1002	4.10	1025	4.31	1047	4.52	1068	4.73	1089	4.94	
7200	901	3.54	928	3.76	954	3.98	979	4.19	1003	4.41	1026	4.63	1049	4.86	1071	5.08	1092	5.31	1113	5.54	

Notes:

1. For Standard Evaporator Fan Speed (rpm), reference [Table 27, p. 42](#).
2. For High Evaporator Fan Speed (rpm), reference [Table 29, p. 42](#).
3. Fan motor heat (MBh) = 3.15 x Fan bhp.
4. Data includes pressure drop due to standard filters and wet coils. No accessories or options are included in pressure drop data.
5. For all non-standard sheave combinations, please refer to accessory installer's guides ACC-SVN163*-EN and ACC-SVN169*-EN.
6. Factory supplied motors, in commercial equipment, are definite purpose motors, specifically designed and tested to operate reliably and continuously at all cataloged conditions. Using the full horsepower range of our fan motors as shown in our tabular data will not result in nuisance tripping or premature motor failure. Our product's warranty will not be affected.



Performance Data

Table 13. Evaporator fan performance - 17½ ton unit with gas heat - GBC210 - downflow airflow

External Static Pressure (Inches of Water)																					
		0.10		0.20		0.30		0.40		0.50		0.60		0.70		0.80		0.90		1.00	
cfm	rpm	bhp	rpm	bhp	rpm	bhp	rpm	bhp	rpm	bhp	rpm	bhp	rpm	bhp	rpm	bhp	rpm	bhp	rpm	bhp	
5-hp Standard Motor & Low Static Drive Accessory										5-hp Standard Motor Drive											
5600	554	1.06	592	1.21	627	1.34	658	1.47	693	1.63	725	1.77	755	1.92	783	2.07	811	2.22	837	2.37	
6300	613	1.46	649	1.63	681	1.79	711	1.94	739	2.09	769	2.26	799	2.43	826	2.59	853	2.75	878	2.92	
7000	673	1.96	706	2.15	737	2.33	765	2.51	792	2.67	817	2.84	844	3.02	871	3.21	897	3.39	921	3.58	
7700	733	2.57	764	2.78	794	2.98	820	3.18	846	3.37	870	3.55	893	3.73	916	3.92	941	4.13	965	4.34	
8400	794	3.29	823	3.52	851	3.75	877	3.96	901	4.17	924	4.38	946	4.58	967	4.78	987	4.97	1011	5.20	
										5-hp Standard Motor & High Static Drive Accessory											

Continued

External Static Pressure (Inches of Water)																					
		1.10		1.20		1.30		1.40		1.50		1.60		1.70		1.80		1.90		2.00	
cfm	rpm	bhp	rpm	bhp	rpm	bhp	rpm	bhp	rpm	bhp	rpm	bhp	rpm	bhp	rpm	bhp	rpm	bhp	rpm	bhp	
5-hp Standard Motor Drive										5-hp Standard Motor & High Static Drive Accessory											
5600	862	2.52	886	2.67	909	2.81	931	2.96	953	3.11	976	3.30	998	3.48	1019	3.67	1040	3.86	1061	4.05	
6300	903	3.09	926	3.26	949	3.43	971	3.60	992	3.76	1013	3.93	1033	4.10	1053	4.26	1072	4.43	1093	4.64	
7000	945	3.75	968	3.94	990	4.13	1012	4.32	1033	4.51	1053	4.70	1073	4.88	1093	5.07	1112	5.25	1130	5.44	
7700	989	4.54	1011	4.74	1033	4.94	1054	5.13	1075	5.34	1095	5.55	1114	5.76	1134	5.97	1152	6.18	1170	6.38	
8400	1033	5.43	1055	5.65	1077	5.87	1097	6.09	1118	6.31	1137	6.52	1156	6.74	1175	6.97	1194	7.20	---	---	
										7.5-hp Oversized Motor & Drive											

Notes:

1. For Standard Evaporator Fan Speed (rpm), reference [Table 27, p. 42](#).
2. For High Evaporator Fan Speed (rpm), reference [Table 29, p. 42](#).
3. For Oversized Evaporator Fan Speed (rpm), reference [Table 30, p. 42](#).
4. Fan motor heat (MBh) = 3.15 x Fan bhp.
5. Data includes pressure drop due to standard filters and wet coils. No accessories or options are included in pressure drop data.
6. For all non-standard sheave combinations, please refer to accessory installer's guides ACC-SVN163*-EN and ACC-SVN169*-EN.
7. Factory supplied motors, in commercial equipment, are definite purpose motors, specifically designed and tested to operate reliably and continuously at all cataloged conditions. Using the full horsepower range of our fan motors as shown in our tabular data will not result in nuisance tripping or premature motor failure. Our product's warranty will not be affected.

Table 14. Evaporator fan performance - 17½ ton unit with gas heat - GBC210 - horizontal airflow

External Static Pressure (Inches of Water)																					
		0.10		0.20		0.30		0.40		0.50		0.60		0.70		0.80		0.90		1.00	
cfm	rpm	bhp	rpm	bhp	rpm	bhp	rpm	bhp	rpm	bhp	rpm	bhp	rpm	bhp	rpm	bhp	rpm	bhp	rpm	bhp	
5-hp Standard Motor & Low Static Drive Accessory											5-hp Standard Motor Drive										
5600	561	1.12	599	1.26	635	1.43	670	1.58	702	1.73	732	1.88	761	2.03	788	2.18	816	2.36	843	2.53	
6300	622	1.56	656	1.71	689	1.88	721	2.07	751	2.24	780	2.41	808	2.58	834	2.74	859	2.91	884	3.08	
7000	684	2.10	714	2.26	745	2.44	774	2.64	803	2.85	830	3.04	857	3.22	882	3.41	906	3.60	930	3.79	
7700	747	2.76	775	2.93	802	3.12	829	3.32	856	3.55	882	3.78	907	3.99	931	4.19	955	4.40	977	4.61	
8400	810	3.54	836	3.74	860	3.93	886	4.15	910	4.37	935	4.63	959	4.87	982	5.10	1004	5.33	1026	5.55	
											5-hp Standard Motor & High Static Drive Accessory										

Continued

External Static Pressure (Inches of Water)																					
		1.10		1.20		1.30		1.40		1.50		1.60		1.70		1.80		1.90		2.00	
cfm	rpm	bhp	rpm	bhp	rpm	bhp	rpm	bhp	rpm	bhp	rpm	bhp	rpm	bhp	rpm	bhp	rpm	bhp	rpm	bhp	
5-hp Standard Motor Drive											5-hp Standard Motor & High Static Drive Accessory										
5600	869	2.71	894	2.89	919	3.07	942	3.25	965	3.43	988	3.61	1010	3.79	1031	3.98	1052	4.16	1073	4.35	
6300	909	3.28	933	3.48	956	3.68	979	3.88	1001	4.08	1023	4.28	1045	4.48	1066	4.69	1086	4.89	1106	5.09	
7000	952	3.97	974	4.16	996	4.37	1019	4.59	1041	4.81	1062	5.03	1082	5.25	1102	5.48	1122	5.70	1142	5.93	
7700	999	4.81	1021	5.02	1041	5.23	1061	5.43	1081	5.64	1102	5.88	1122	6.12	1142	6.37	1161	6.61	1180	6.85	
8400	1047	5.78	1068	6.01	1088	6.23	1108	6.45	1127	6.68	1146	6.90	1164	7.13	1182	7.35	1201	7.62	---	---	
											7.5-hp Oversized Motor & Drive										

Notes:

1. For Standard Evaporator Fan Speed (rpm), reference [Table 27, p. 42](#).
2. For High Evaporator Fan Speed (rpm), reference [Table 29, p. 42](#).
3. For Oversized Evaporator Fan Speed (rpm), reference [Table 30, p. 42](#).
4. Fan motor heat (MBh) = 3.15 x Fan bhp.
5. Data includes pressure drop due to standard filters and wet coils. No accessories or options are included in pressure drop data.
6. For all non-standard sheave combinations, please refer to accessory installer's guides ACC-SVN163*-EN and ACC-SVN169*-EN.
7. Factory supplied motors, in commercial equipment, are definite purpose motors, specifically designed and tested to operate reliably and continuously at all cataloged conditions. Using the full horsepower range of our fan motors as shown in our tabular data will not result in nuisance tripping or premature motor failure. Our product's warranty will not be affected.



Performance Data

Table 15. Evaporator fan performance - 17½ ton cooling only units (model number digit 8 = 3, 4, W, K) - EBC210 - downflow airflow

External Static Pressure (Inches of Water)																					
		0.10		0.20		0.30		0.40		0.50		0.60		0.70		0.80		0.90		1.00	
cfm	rpm	bhp	rpm	bhp	rpm	bhp	rpm	bhp	rpm	bhp	rpm	bhp	rpm	bhp	rpm	bhp	rpm	bhp	rpm	bhp	
5-hp Standard Motor & Low Static Drive Accessory												5-hp Standard Motor Drive									
5600	---	---	---	---	---	---	572	1.08	608	1.21	641	1.33	675	1.46	709	1.59	740	1.72	771	1.85	
6300	---	---	---	---	566	1.23	606	1.38	642	1.53	674	1.68	705	1.81	733	1.95	764	2.10	794	2.25	
7000	---	---	559	1.38	601	1.56	640	1.74	676	1.91	708	2.07	738	2.24	766	2.39	792	2.54	818	2.69	
7700	551	1.52	597	1.74	638	1.95	675	2.15	710	2.35	742	2.53	771	2.71	799	2.89	825	3.07	850	3.24	
8400	593	1.93	636	2.17	675	2.41	711	2.63	744	2.85	776	3.06	805	3.26	833	3.46	859	3.65	883	3.85	

Continued

External Static Pressure (Inches of Water)																					
		1.10		1.20		1.30		1.40		1.50		1.60		1.70		1.80		1.90		2.00	
cfm	rpm	bhp	rpm	bhp	rpm	bhp	rpm	bhp	rpm	bhp	rpm	bhp	rpm	bhp	rpm	bhp	rpm	bhp	rpm	bhp	
5-hp Standard Motor Drive												5-hp Standard Motor & High Static Drive Accessory									
5600	801	2.02	831	2.19	859	2.36	886	2.53	912	2.70	938	2.88	961	3.05	983	3.22	1004	3.39	1025	3.56	
6300	822	2.40	849	2.54	877	2.71	904	2.89	930	3.08	955	3.28	980	3.47	1004	3.66	1027	3.85	1049	4.05	
7000	846	2.86	873	3.03	899	3.19	924	3.35	948	3.51	973	3.70	997	3.91	1021	4.12	1044	4.33	1067	4.55	
7700	874	3.40	897	3.57	923	3.75	948	3.94	972	4.12	995	4.30	1018	4.47	1040	4.65	1062	4.84	1084	5.07	
8400	907	4.04	929	4.22	951	4.40	973	4.58	995	4.78	1019	4.98	1041	5.18	1063	5.38	1085	5.57	1105 ^(a)	5.76	

Notes:

1. For Standard Evaporator Fan Speed (rpm), reference [Table 27, p. 42](#).
2. For High Evaporator Fan Speed (rpm), reference [Table 29, p. 42](#).
3. For Oversized Evaporator Fan Speed (rpm), reference [Table 30, p. 42](#).
4. Fan motor heat (MBh) = 3.15 x Fan bhp.
5. Data includes pressure drop due to standard filters and wet coils. No accessories or options are included in pressure drop data.
6. For all non-standard sheave combinations, please refer to accessory installer's guides ACC-SVN163*-EN and ACC-SVN169*-EN.
7. Factory supplied motors, in commercial equipment, are definite purpose motors, specifically designed and tested to operate reliably and continuously at all cataloged conditions. Using the full horsepower range of our fan motors as shown in our tabular data will not result in nuisance tripping or premature motor failure. Our product's warranty will not be affected.

(a) 7.5-hp Oversized Motor & Drive

Table 16. Evaporator fan performance - 17½ ton cooling only units (model number digit 8 = 3, 4, W, K) - EBC210 - horizontal airflow

External Static Pressure (Inches of Water)																					
		0.10		0.20		0.30		0.40		0.50		0.60		0.70		0.80		0.90		1.00	
cfm	rpm	bhp	rpm	bhp	rpm	bhp	rpm	bhp	rpm	bhp	rpm	bhp	rpm	bhp	rpm	bhp	rpm	bhp	rpm	bhp	
5-hp Standard Motor & Low Static Drive Accessory											5-hp Standard Motor Drive										
5600	---	---	529	0.97	569	1.11	605	1.24	645	1.41	683	1.58	719	1.75	752	1.92	783	2.09	813	2.27	
6300	---	---	573	1.29	613	1.46	647	1.61	679	1.75	714	1.94	749	2.14	782	2.33	813	2.52	842	2.72	
7000	571	1.45	617	1.67	657	1.87	691	2.05	721	2.21	749	2.37	780	2.57	813	2.79	843	3.01	872	3.22	
7700	617	1.87	663	2.13	701	2.35	735	2.57	764	2.76	792	2.94	818	3.11	844	3.30	874	3.55	903	3.79	
8400	664	2.37	709	2.67	745	2.92	778	3.16	809	3.39	835	3.59	860	3.79	884	3.98	907	4.17	934	4.42	

Continued

External Static Pressure (Inches of Water)																					
		1.10		1.20		1.30		1.40		1.50		1.60		1.70		1.80		1.90		2.00	
cfm	rpm	bhp	rpm	bhp	rpm	bhp	rpm	bhp	rpm	bhp	rpm	bhp	rpm	bhp	rpm	bhp	rpm	bhp	rpm	bhp	
5-hp Standard Motor Drive											5-hp Standard Motor & High Static Drive Accessory										
5600	841	2.45	868	2.62	894	2.80	919	2.98	944	3.16	967	3.34	990	3.52	1012	3.70	1034	3.88	1055	4.06	
6300	871	2.90	898	3.10	923	3.30	948	3.50	972	3.70	996	3.90	1018	4.10	1041	4.30	1062	4.50	1083	4.71	
7000	900	3.44	927	3.65	953	3.86	978	4.07	1002	4.29	1025	4.51	1047	4.74	1069	4.96	1091	5.18	1112	5.41	
7700	930	4.03	957	4.27	982	4.50	1007	4.74	1031	4.97	1054	5.20	1077	5.43	1099	5.67	1120	5.92	1141	6.16	
8400	961	4.68	987	4.95	1013	5.21	1037	5.47	1061	5.73	1084	5.98	1106	6.24	1128	6.49	1149	6.75	---	---	
7.5-hp Oversized Motor & Drive																					

Notes:

1. For Standard Evaporator Fan Speed (rpm), reference [Table 27, p. 42](#).
2. For High Evaporator Fan Speed (rpm), reference [Table 29, p. 42](#).
3. For Oversized Evaporator Fan Speed (rpm), reference [Table 30, p. 42](#).
4. Fan motor heat (MBh) = 3.15 x Fan bhp.
5. Data includes pressure drop due to standard filters and wet coils. No accessories or options are included in pressure drop data.
6. For all non-standard sheave combinations, please refer to accessory installer's guides ACC-SVN163*-EN and ACC-SVN169*-EN.
7. Factory supplied motors, in commercial equipment, are definite purpose motors, specifically designed and tested to operate reliably and continuously at all cataloged conditions. Using the full horsepower range of our fan motors as shown in our tabular data will not result in nuisance tripping or premature motor failure. Our product's warranty will not be affected.



Performance Data

Table 17. Evaporator fan performance - 20 ton unit with gas heat - GBC240 - downflow airflow

External Static Pressure (Inches of Water)																					
		0.10		0.20		0.30		0.40		0.50		0.60		0.70		0.80		0.90		1.00	
cfm	rpm	bhp	rpm	bhp	rpm	bhp	rpm	bhp	rpm	bhp	rpm	bhp	rpm	bhp	rpm	bhp	rpm	bhp	rpm	bhp	
5-hp Standard Motor & Low Static Drive Accessory											5-hp Standard Motor Drive										
6400	621	1.53	657	1.70	689	1.86	719	2.02	746	2.17	776	2.34	805	2.51	833	2.67	859	2.84	884	3.00	
7200	690	2.12	723	2.32	753	2.51	781	2.69	807	2.86	832	3.03	857	3.21	884	3.40	909	3.60	934	3.78	
8000	759	2.86	790	3.08	818	3.29	844	3.50	869	3.70	893	3.89	915	4.08	937	4.27	961	4.48	985	4.70	
8800	829	3.76	857	4.00	884	4.24	909	4.47	932	4.69	955	4.91	976	5.12	997	5.33	1017	5.54	1037	5.75	
9600	899	4.83	925	5.10	950	5.36	974	5.61	997	5.86	1018	6.10	1039	6.34	1059	6.58	1078	6.81	1097	7.03	
7.5-hp Oversized Motor & Drive																					

Continued

External Static Pressure (Inches of Water)																					
		1.10		1.20		1.30		1.40		1.50		1.60		1.70		1.80		1.90		2.00	
cfm	rpm	bhp	rpm	bhp	rpm	bhp	rpm	bhp	rpm	bhp	rpm	bhp	rpm	bhp	rpm	bhp	rpm	bhp	rpm	bhp	
5-hp Standard Motor Drive											5-hp Standard Motor & High Static Drive Accessory										
6400	909	3.18	932	3.35	955	3.52	977	3.70	998	3.87	1019	4.03	1039	4.20	1059	4.37	1078	4.54	1097	4.73	
7200	957	3.97	980	4.15	1002	4.34	1024	4.54	1045	4.74	1065	4.93	1085	5.12	1104	5.32	1123	5.51	1142	5.70	
8000	1008	4.91	1030	5.12	1052	5.32	1073 ^(a)	5.53	1093 ^(a)	5.73	1113	5.95	1132	6.17	1151	6.38	1170	6.60	1188	6.82	
8800	1059	5.99	1081	6.23	1102	6.46	1123	6.69	1143	6.92	1162	7.15	1181	7.37	1199	7.59	---	---	---	---	
9600	1115	7.26	1133	7.49	1154	7.75	1174	8.01	1193	8.27	1212	8.52	---	---	---	---	---	---	---	---	
7.5-hp Oversized Motor & Drive																					

Notes:

1. For Standard Evaporator Fan Speed (rpm), reference [Table 27, p. 42](#).
2. For High Evaporator Fan Speed (rpm), reference [Table 29, p. 42](#).
3. For Oversized Evaporator Fan Speed (rpm), reference [Table 30, p. 42](#).
4. Fan motor heat (MBh) = 3.15 x Fan bhp.
5. Data includes pressure drop due to standard filters and wet coils. No accessories or options are included in pressure drop data.
6. For all non-standard sheave combinations, please refer to accessory installer's guides ACC-SVN163*-EN and ACC-SVN169*-EN.
7. Factory supplied motors, in commercial equipment, are definite purpose motors, specifically designed and tested to operate reliably and continuously at all cataloged conditions. Using the full horsepower range of our fan motors as shown in our tabular data will not result in nuisance tripping or premature motor failure. Our product's warranty will not be affected.

(a) 5-hp Standard Motor & High Static Drive Accessory

Table 18. Evaporator fan performance - 20 ton unit with gas heat - GBC240 - horizontal airflow

External Static Pressure (Inches of Water)																					
		0.10		0.20		0.30		0.40		0.50		0.60		0.70		0.80		0.90		1.00	
cfm	rpm	bhp	rpm	bhp	rpm	bhp	rpm	bhp	rpm	bhp	rpm	bhp	rpm	bhp	rpm	bhp	rpm	bhp	rpm	bhp	
5-hp Standard Motor & Low Static Drive Accessory											5-hp Standard Motor Drive										
6400	631	1.63	664	1.78	697	1.95	729	2.14	759	2.32	787	2.49	815	2.66	841	2.83	866	3.00	890	3.18	
7200	702	2.28	732	2.44	761	2.62	790	2.83	818	3.04	845	3.24	871	3.43	896	3.62	920	3.82	943	4.01	
8000	774	3.08	801	3.26	827	3.45	853	3.66	879	3.89	905	4.13	929	4.35	953	4.57	976	4.78	998	5.00	
8800	846	4.05	871	4.26	894	4.45	919	4.68	942	4.90	966	5.17	989	5.43	1012	5.68	1034	5.92	1055	6.15	
9600	918	5.22	941	5.44	963	5.66	985	5.88	1007	6.13	1029	6.38	1051	6.67	1072	6.95	1093	7.24	1114	7.50	
7.5-hp Oversized Motor & Drive																					

Continued

External Static Pressure (Inches of Water)																					
		1.10		1.20		1.30		1.40		1.50		1.60		1.70		1.80		1.90		2.00	
cfm	rpm	bhp	rpm	bhp	rpm	bhp	rpm	bhp	rpm	bhp	rpm	bhp	rpm	bhp	rpm	bhp	rpm	bhp	rpm	bhp	
5-hp Standard Motor Drive											5-hp Standard Motor & High Static Drive Accessory										
6400	914	3.36	939	3.57	962	3.77	985	3.97	1007	4.18	1029	4.38	1050	4.59	1071	4.79	1091	5.00	1111	5.21	
7200	966	4.20	987	4.39	1008	4.59	1030	4.81	1052	5.04	1073	5.26	1093	5.49	1113	5.72	1133	5.95	1152	6.18	
8000	1020	5.21	1041	5.42	1061	5.64	1081	5.85	1101	6.07	1120	6.28	1139	6.52	1159	6.78	1178	7.03	1197	7.28	
8800	1076	6.39	1096	6.63	1116	6.87	1135	7.10	1154	7.33	1172	7.57	1190	7.81	1208	8.04	---	---	---	---	
9600	1133	7.76	1153	8.01	1172	8.27	1190	8.53	---	---	---	---	---	---	---	---	---	---	---	---	
7.5-hp Oversized Motor & Drive																					

Notes:

1. For Standard Evaporator Fan Speed (rpm), reference [Table 27, p. 42](#).
2. For High Evaporator Fan Speed (rpm), reference [Table 29, p. 42](#).
3. For Oversized Evaporator Fan Speed (rpm), reference [Table 30, p. 42](#).
4. Fan motor heat (MBh) = 3.15 x Fan bhp.
5. Data includes pressure drop due to standard filters and wet coils. No accessories or options are included in pressure drop data.
6. For all non-standard sheave combinations, please refer to accessory installer's guides ACC-SVN163*-EN and ACC-SVN169*-EN.
7. Factory supplied motors, in commercial equipment, are definite purpose motors, specifically designed and tested to operate reliably and continuously at all cataloged conditions. Using the full horsepower range of our fan motors as shown in our tabular data will not result in nuisance tripping or premature motor failure. Our product's warranty will not be affected.



Performance Data

Table 19. Evaporator fan performance - 20 ton cooling only units (model number digit 8 = 3, 4, W, K) - EBC240 - downflow airflow

External Static Pressure (Inches of Water)																					
		0.10		0.20		0.30		0.40		0.50		0.60		0.70		0.80		0.90		1.00	
cfm	rpm	bhp	rpm	bhp	rpm	bhp	rpm	bhp	rpm	bhp	rpm	bhp	rpm	bhp	rpm	bhp	rpm	bhp	rpm	bhp	
5-hp Standard Motor & Low Static Drive Accessory											5-hp Standard Motor Drive										
6400	---	---	---	---	571	1.28	611	1.43	647	1.58	679	1.73	709	1.87	738	2.01	767	2.16	797	2.31	
7200	---	---	570	1.48	612	1.67	650	1.85	685	2.03	718	2.20	747	2.37	775	2.53	801	2.69	827	2.84	
8000	569	1.69	614	1.92	653	2.14	690	2.35	724	2.55	756	2.75	786	2.94	813	3.13	839	3.31	864	3.49	
8800	617	2.19	658	2.45	697	2.70	731	2.93	764	3.16	795	3.39	825	3.60	852	3.81	878	4.02	902	4.23	
9600	665	2.79	704	3.07	740	3.35	774	3.61	805	3.86	835	4.12	864	4.36	891	4.60	917	4.83	942	5.06	

Continued

External Static Pressure (Inches of Water)																					
		1.10		1.20		1.30		1.40		1.50		1.60		1.70		1.80		1.90		2.00	
cfm	rpm	bhp	rpm	bhp	rpm	bhp	rpm	bhp	rpm	bhp	rpm	bhp	rpm	bhp	rpm	bhp	rpm	bhp	rpm	bhp	
5-hp Standard Motor Drive											5-hp Standard Motor & High Static Drive Accessory										
6400	826	2.46	853	2.61	879	2.76	906	2.95	932	3.14	958	3.33	982	3.53	1006	3.72	1029	3.92	1052	4.12	
7200	853	3.00	880	3.18	906	3.35	931	3.52	955	3.68	978	3.84	1002	4.04	1026	4.26	1049	4.48	1072	4.69	
8000	888	3.67	911	3.84	933	4.01	958	4.20	982	4.39	1005	4.58	1028	4.77	1050	4.95	1071	5.14	1092	5.31	
8800	926	4.43	948	4.63	970	4.82	991	5.01	1012	5.20	1032	5.39	1055	5.61	1077	5.82	1098	6.03	1119	6.23	
9600	964	5.29	987	5.51	1008	5.73	1029	5.95	1049	6.16	1069	6.37	1088	6.57	1106	6.78	1125	6.99	1146	7.22	
7.5-hp Oversized Motor & Drive																					

Notes:

1. For Standard Evaporator Fan Speed (rpm), reference [Table 27, p. 42](#).
2. For High Evaporator Fan Speed (rpm), reference [Table 29, p. 42](#).
3. For Oversized Evaporator Fan Speed (rpm), reference [Table 30, p. 42](#).
4. Fan motor heat (MBh) = 3.15 x Fan bhp.
5. Data includes pressure drop due to standard filters and wet coils. No accessories or options are included in pressure drop data.
6. For all non-standard sheave combinations, please refer to accessory installer's guides ACC-SVN163*-EN and ACC-SVN169*-EN.
7. Factory supplied motors, in commercial equipment, are definite purpose motors, specifically designed and tested to operate reliably and continuously at all cataloged conditions. Using the full horsepower range of our fan motors as shown in our tabular data will not result in nuisance tripping or premature motor failure. Our product's warranty will not be affected.

Table 20. Evaporator fan performance - 20 ton cooling only units (model number digit 8 = 3, 4, W, K) - EBC240 - horizontal airflow

External Static Pressure (Inches of Water)																					
		0.10		0.20		0.30		0.40		0.50		0.60		0.70		0.80		0.90		1.00	
cfm	rpm	bhp	rpm	bhp	rpm	bhp	rpm	bhp	rpm	bhp	rpm	bhp	rpm	bhp	rpm	bhp	rpm	bhp	rpm	bhp	
5-hp Standard Motor & Low Static Drive Accessory											5-hp Standard Motor Drive										
6400	---	---	579	1.34	620	1.51	653	1.67	685	1.81	719	1.99	754	2.19	786	2.39	817	2.59	847	2.78	
7200	584	1.56	630	1.79	669	2.00	703	2.19	733	2.36	761	2.53	789	2.70	821	2.93	852	3.16	881	3.38	
8000	637	2.07	683	2.35	719	2.59	753	2.81	783	3.02	810	3.21	836	3.39	860	3.57	888	3.80	916	4.05	
8800	691	2.69	736	3.01	771	3.28	803	3.53	834	3.78	860	4.00	885	4.21	909	4.42	931	4.62	953	4.82	
9600	746	3.42	787	3.78	823	4.09	854	4.38	883	4.65	911	4.92	935	5.16	958 ^(a)	5.40	980	5.62	1001 ^(b)	5.84	

Continued

External Static Pressure (Inches of Water)																					
		1.10		1.20		1.30		1.40		1.50		1.60		1.70		1.80		1.90		2.00	
cfm	rpm	bhp	rpm	bhp	rpm	bhp	rpm	bhp	rpm	bhp	rpm	bhp	rpm	bhp	rpm	bhp	rpm	bhp	rpm	bhp	
5-hp Standard Motor Drive											5-hp Standard Motor & High Static Drive Accessory										
6400	875	2.98	902	3.17	928	3.37	952	3.58	977	3.78	1000	3.98	1023	4.19	1045	4.39	1066	4.60	1087	4.80	
7200	909	3.60	935	3.82	961	4.04	986	4.26	1010	4.47	1033	4.70	1056	4.93	1078	5.16	1099	5.39	1120	5.62	
8000	944	4.30	970	4.55	995	4.80	1020	5.04	1044	5.29	1067	5.53	1089	5.77	1111	6.01	1133	6.25	1153	6.51	
8800	979	5.08	1005	5.36	1030	5.64	1055	5.92	1078	6.19	1101	6.46	1123	6.73	1145	7.00	1166	7.26	1187	7.53	
9600	1022	6.06	1042	6.28	1066	6.57	1090	6.88	1113	7.18	1136	7.48	1158	7.78	1179	8.08	1200	8.37	---	---	
7.5-hp Oversized Motor & Drive																					

Notes:

1. For Standard Evaporator Fan Speed (rpm), reference [Table 27, p. 42](#).
2. For High Evaporator Fan Speed (rpm), reference [Table 29, p. 42](#).
3. For Oversized Evaporator Fan Speed (rpm), reference [Table 30, p. 42](#).
4. Fan motor heat (MBh) = 3.15 x Fan bhp.
5. Data includes pressure drop due to standard filters and wet coils. No accessories or options are included in pressure drop data.
6. For all non-standard sheave combinations, please refer to accessory installer's guides ACC-SVN163*-EN and ACC-SVN169*-EN.
7. Factory supplied motors, in commercial equipment, are definite purpose motors, specifically designed and tested to operate reliably and continuously at all cataloged conditions. Using the full horsepower range of our fan motors as shown in our tabular data will not result in nuisance tripping or premature motor failure. Our product's warranty will not be affected.

(a) 5-hp Standard Motor & High Static Drive Accessory
 (b) 7.5-hp Oversized Motor & Drive



Performance Data

Table 21. Evaporator fan performance - 25 ton unit with gas heat - GBC300 - downflow airflow

External Static Pressure (Inches of Water)																					
		0.10		0.20		0.30		0.40		0.50		0.60		0.70		0.80		0.90		1.00	
cfm	rpm	bhp	rpm	bhp	rpm	bhp	rpm	bhp	rpm	bhp	rpm	bhp	rpm	bhp	rpm	bhp	rpm	bhp	rpm	bhp	
7.5-hp Standard Motor & Field Supplied Drive ^(a)											7.5-hp Standard Motor & Low Static Drive Accessory										
7000	---	---	706	2.15	737	2.33	765	2.51	792	2.67	817	2.84	844	3.02	871	3.21	897	3.39	921	3.58	
7500	716	2.38	748	2.59	777	2.78	804	2.97	830	3.16	854	3.34	878	3.51	903	3.71	928	3.91	953	4.11	
8000	759	2.86	790	3.08	818	3.29	844	3.50	869	3.70	893	3.89	915	4.08	937	4.27	961	4.48	985	4.70	
8500	803	3.40	832	3.64	859	3.86	885	4.08	909	4.30	931	4.51	953	4.71	974	4.91	995	5.11	1017	5.34	
9000	846	4.01	874	4.26	900	4.50	925	4.74	948	4.97	971	5.19	992	5.41	1012	5.63	1032	5.84	1052	6.05	
9500	890	4.68	917	4.95	942	5.21	966	5.46	989	5.70	1010	5.94	1031	6.18	1051	6.41	1070	6.64	1089	6.86	
10000	934	5.43	960	5.71	984	5.99	1007	6.25	1029	6.51	1050	6.77	1070	7.02	1090	7.27	1109	7.51	1127	7.75	
10500	978	6.25	1003	6.55	1026	6.84	1049	7.12	1070	7.40	1091	7.67	1110	7.94	1129	8.20	1148	8.46	1166	8.71	
11000	1022	7.16	1046	7.47	1069	7.78	1090	8.08	1111	8.37	1131	8.66	1151	8.94	1169	9.21	1187	9.49	1204	9.76	
7.5-hp Standard Motor & Drive											10-hp Oversized Motor & Drive										

Continued

External Static Pressure (Inches of Water)																					
		1.10		1.20		1.30		1.40		1.50		1.60		1.70		1.80		1.90		2.00	
cfm	rpm	bhp	rpm	bhp	rpm	bhp	rpm	bhp	rpm	bhp	rpm	bhp	rpm	bhp	rpm	bhp	rpm	bhp	rpm	bhp	
7.5-hp Standard Motor & Low Static Drive Accessory											7.5-hp Standard Motor & Drive										
7000	945	3.75	968	3.94	990	4.13	1012	4.32	1033	4.51	1053	4.70	1073	4.88	1093	5.07	1112	5.25	1130	5.44	
7500	976	4.31	999	4.50	1021	4.69	1042	4.89	1063	5.09	1083	5.30	1103	5.50	1122	5.70	1141	5.90	1159	6.10	
8000	1008	4.91	1030	5.12	1052	5.32	1073	5.53	1093	5.73	1113	5.95	1132	6.17	1151	6.38	1170	6.60	1188	6.82	
8500	1040	5.57	1062	5.79	1083	6.02	1104	6.24	1124	6.46	1143	6.67	1162	6.89	1181	7.12	1200	7.35	1218	7.58	
9000	1072	6.28	1094	6.53	1115	6.77	1135	7.01	1155	7.24	1174	7.48	1193	7.71	1212	7.94	1230	8.16	1248	8.41	
9500	1107	7.08	1127	7.32	1147	7.58	1167	7.84	1187	8.09	1206	8.34	1225	8.59	1243	8.84	1261	9.08	1278	9.32	
10000	1145	7.99	1163	8.22	1180	8.46	1200	8.73	1219	9.00	1238	9.27	1256	9.54	1274	9.80	1292	10.06	1309	10.32	
10500	1183	8.96	1200	9.21	1217	9.46	1233	9.70	1252	9.98	1270	10.27	1288	10.55	1306	10.83	---	---	---	---	
11000	1222	10.02	1238	10.29	1255	10.55	1271	10.81	1286	11.06	1303	11.34	---	---	---	---	---	---	---	---	
10-hp Oversized Motor & Drive																					

Notes:

1. For Standard Evaporator Fan Speed (rpm), reference [Table 27, p. 42](#).
2. For High Evaporator Fan Speed (rpm), reference [Table 29, p. 42](#).
3. For Oversized Evaporator Fan Speed (rpm), reference [Table 30, p. 42](#).
4. Fan motor heat (MBh) = 3.15 x Fan bhp.
5. Data includes pressure drop due to standard filters and wet coils. No accessories or options are included in pressure drop data.
6. For all non-standard sheave combinations, please refer to accessory installer's guides ACC-SVN163*-EN and ACC-SVN169*-EN.
7. Factory supplied motors, in commercial equipment, are definite purpose motors, specifically designed and tested to operate reliably and continuously at all cataloged conditions. Using the full horsepower range of our fan motors as shown in our tabular data will not result in nuisance tripping or premature motor failure. Our product's warranty will not be affected.
8. For multi-speed fan operation, max allowable bhp is 10.0.

(a) Field supplied BK160 x 1.4375" fan sheave, 1VP44 x 1.125" motor sheave, and BX60 belt.

Table 22. Evaporator fan performance - 25 ton unit with gas heat - GBC300 - horizontal airflow

External Static Pressure (Inches of Water)																					
		0.10		0.20		0.30		0.40		0.50		0.60		0.70		0.80		0.90		1.00	
cfm	rpm	bhp	rpm	bhp	rpm	bhp	rpm	bhp	rpm	bhp	rpm	bhp	rpm	bhp	rpm	bhp	rpm	bhp	rpm	bhp	
7.5-hp Standard Motor & Field Supplied Drive ^(a)										7.5-hp Standard Motor & Low Static Drive Accessory											
7000	---	---	714	2.26	745	2.44	774	2.64	803	2.85	830	3.04	857	3.22	882	3.41	906	3.60	930	3.79	
7500	729	2.56	757	2.73	786	2.92	813	3.12	841	3.34	867	3.55	892	3.76	917	3.96	941	4.16	964	4.36	
8000	774	3.08	801	3.26	827	3.45	853	3.66	879	3.89	905	4.13	929	4.35	953	4.57	976	4.78	998	5.00	
8500	819	3.67	844	3.86	869	4.05	894	4.28	918	4.50	943	4.76	967	5.01	990	5.24	1012	5.47	1033	5.70	
9000	864	4.33	888	4.54	912	4.74	935	4.96	958	5.19	982	5.45	1005	5.72	1027	5.98	1048	6.23	1069	6.47	
9500	909	5.06	932	5.29	955	5.50	977	5.72	999	5.97	1021	6.21	1043	6.50	1065	6.79	1086	7.06	1106	7.32	
10000	954	5.88	977	6.12	998	6.34	1019	6.56	1040	6.82	1061	7.08	1082	7.35	1103	7.66	1123	7.96	1143	8.24	
10500	1000	6.78	1021	7.03	1042	7.27	1062	7.50	1082	7.76	1102	8.03	1122	8.30	1142	8.60	1162	8.92	1181	9.23	
11000	1045	7.77	1066	8.03	1086	8.28	1105	8.53	1124	8.78	1144	9.07	1162	9.35	1181	9.63	1200	9.96	1219	10.30	
7.5-hp Standard Motor & Drive										10-hp Oversized Motor & Drive											

Continued

External Static Pressure (Inches of Water)																					
		1.10		1.20		1.30		1.40		1.50		1.60		1.70		1.80		1.90		2.00	
cfm	rpm	bhp	rpm	bhp	rpm	bhp	rpm	bhp	rpm	bhp	rpm	bhp	rpm	bhp	rpm	bhp	rpm	bhp	rpm	bhp	
7.5-hp Standard Motor & Drive																					
7000	952	3.97	974	4.16	996	4.37	1019	4.59	1041	4.81	1062	5.03	1082	5.25	1102	5.48	1122	5.70	1142	5.93	
7500	986	4.56	1007	4.76	1028	4.96	1048	5.16	1069	5.39	1090	5.63	1110	5.86	1130	6.10	1150	6.34	1169	6.58	
8000	1020	5.21	1041	5.42	1061	5.64	1081	5.85	1101	6.07	1120	6.28	1139	6.52	1159	6.78	1178	7.03	1197	7.28	
8500	1054	5.93	1075	6.16	1095	6.38	1115	6.61	1134	6.84	1152	7.07	1171	7.29	1188	7.52	1207	7.77	1225	8.04	
9000	1090	6.71	1110	6.96	1130	7.20	1149	7.44	1167	7.68	1186	7.92	1204	8.16	1221	8.40	1239	8.64	1255	8.88	
9500	1126	7.57	1145	7.83	1165	8.09	1183	8.34	1202	8.60	1220	8.85	1237	9.10	1255	9.35	1272	9.61	1288	9.87	
10000	1163	8.52	1182	8.78	1200	9.05	1218	9.32	1237	9.59	1254	9.86	1272	10.13	1289	10.40	1305	10.66	---	---	
10500	1200	9.53	1219	9.82	1237	10.10	1254	10.38	1272	10.66	1289	10.95	1306	11.24	---	---	---	---	---	---	
11000	1238	10.62	1256	10.94	1274	11.24	---	---	---	---	---	---	---	---	---	---	---	---	---	---	
10-hp Oversized Motor & Drive																					

Notes:

1. For Standard Evaporator Fan Speed (rpm), reference [Table 27, p. 42](#).
2. For High Evaporator Fan Speed (rpm), reference [Table 29, p. 42](#).
3. For Oversized Evaporator Fan Speed (rpm), reference [Table 30, p. 42](#).
4. Fan motor heat (MBh) = 3.15 x Fan bhp.
5. Data includes pressure drop due to standard filters and wet coils. No accessories or options are included in pressure drop data.
6. For all non-standard sheave combinations, please refer to accessory installer's guides ACC-SVN163*-EN and ACC-SVN169*-EN.
7. Factory supplied motors, in commercial equipment, are definite purpose motors, specifically designed and tested to operate reliably and continuously at all cataloged conditions. Using the full horsepower range of our fan motors as shown in our tabular data will not result in nuisance tripping or premature motor failure. Our product's warranty will not be affected.
8. For multi-speed fan operation, max allowable bhp is 10.0.

(a) Field supplied BK160 x 1.4375" fan sheave, 1VP44 x 1.125" motor sheave, and BX60 belt.



Performance Data

Table 23. Evaporator fan performance - 25 ton cooling only unit - EBC300 (model number digit 8 = 3, 4, W)- downflow airflow

External Static Pressure (Inches of Water)																					
		0.10		0.20		0.30		0.40		0.50		0.60		0.70		0.80		0.90		1.00	
cfm	rpm	bhp	rpm	bhp	rpm	bhp	rpm	bhp	rpm	bhp	rpm	bhp	rpm	bhp	rpm	bhp	rpm	bhp	rpm	bhp	
7.5-hp Standard Motor & Field Supplied Drive ^(a)											7.5-hp Standard Motor & Low Static Drive Accessory										
7000	---	---	---	---	601	1.56	640	1.74	676	1.91	708	2.07	738	2.24	766	2.39	792	2.54	818	2.69	
7500	---	---	586	1.63	627	1.83	665	2.03	700	2.22	732	2.39	762	2.57	789	2.74	816	2.91	841	3.07	
8000	---	---	614	1.92	653	2.14	690	2.35	724	2.55	756	2.75	786	2.94	813	3.13	839	3.31	864	3.49	
8500	599	1.99	642	2.24	680	2.48	716	2.70	749	2.92	781	3.14	810	3.34	838	3.54	863	3.74	888	3.94	
9000	629	2.33	670	2.60	707	2.85	742	3.09	775	3.33	805	3.56	834	3.79	862	4.00	888	4.21	912	4.43	
9500	659	2.71	698	2.99	735	3.26	769	3.52	800	3.77	830	4.02	859	4.26	886	4.50	912	4.73	937	4.95	
10000	689	3.13	727	3.42	763	3.72	796	3.99	826	4.25	856	4.52	884	4.78	911	5.03	936	5.28	961	5.52	
10500	720	3.59	756	3.90	791	4.21	823	4.50	853	4.78	881	5.06	909	5.34	935	5.61	961	5.87	985	6.13	
11000	750	4.10	786	4.42	819	4.75	850	5.06	880	5.36	908	5.65	934	5.94	960	6.23	985	6.51	1009	6.79	
											7.5-hp Standard Motor & Drive										

Continued

External Static Pressure (Inches of Water)																					
		1.10		1.20		1.30		1.40		1.50		1.60		1.70		1.80		1.90		2.00	
cfm	rpm	bhp	rpm	bhp	rpm	bhp	rpm	bhp	rpm	bhp	rpm	bhp	rpm	bhp	rpm	bhp	rpm	bhp	rpm	bhp	
7.5-hp Standard Motor & Drive																					
7000	846	2.86	873	3.03	899	3.19	924	3.35	948	3.51	973	3.70	997	3.91	1021	4.12	1044	4.33	1067	4.55	
7500	865	3.23	890	3.41	916	3.59	941	3.77	965	3.94	988	4.11	1011	4.28	1034	4.47	1057	4.69	1079	4.92	
8000	888	3.67	911	3.84	933	4.01	958	4.20	982	4.39	1005	4.58	1028	4.77	1050	4.95	1071	5.14	1092	5.31	
8500	911	4.13	934	4.32	956	4.50	977	4.69	999	4.87	1022	5.08	1045	5.28	1067	5.48	1088	5.68	1109	5.88	
9000	935	4.63	958	4.84	979	5.04	1001	5.23	1021	5.43	1041	5.62	1062	5.83	1084	6.04	1105	6.26	1126	6.47	
9500	960	5.17	982	5.39	1003	5.61	1024	5.82	1044	6.03	1064	6.24	1083	6.44	1102	6.64	1122	6.86	1143	7.09	
10000	984	5.75	1006	5.99	1027	6.22	1048	6.45	1068	6.68	1087	6.90	1106	7.12	1125	7.34	1143	7.55	1161	7.76	
10500	1008	6.38	1031	6.63	1052	6.88	1072	7.12	1092	7.36	1111	7.60	1130	7.84	1148	8.07	1166	8.30	1184	8.53	
11000	1032	7.06	1055	7.32	1076	7.58	1096	7.84	1116	8.10	1135	8.35	1154	8.60	1172	8.85	1190	9.10	1207	9.34	
											7.5-hp Standard Motor & High Static Drive Accessory						10-hp Oversized Motor & Drive				

Notes:

1. For Standard Evaporator Fan Speed (rpm), reference [Table 27, p. 42](#).
2. For High Evaporator Fan Speed (rpm), reference [Table 29, p. 42](#).
3. For Oversized Evaporator Fan Speed (rpm), reference [Table 30, p. 42](#).
4. Fan motor heat (MBh) = 3.15 x Fan bhp.
5. Data includes pressure drop due to standard filters and wet coils. No accessories or options are included in pressure drop data.
6. For all non-standard sheave combinations, please refer to accessory installer's guides ACC-SVN163*-EN and ACC-SVN169*-EN.
7. Factory supplied motors, in commercial equipment, are definite purpose motors, specifically designed and tested to operate reliably and continuously at all cataloged conditions. Using the full horsepower range of our fan motors as shown in our tabular data will not result in nuisance tripping or premature motor failure. Our product's warranty will not be affected.
8. For multi-speed fan operation, max allowable bhp is 10.0.

(a) Field supplied BK190 x 1.4375" fan sheave, 1VP44 x 1.125" motor sheave, and BX66 belt.

Table 24. Evaporator fan performance - 25 ton cooling only unit (model number digit 8 = 3, 4, W) - EBC300 - horizontal airflow

External Static Pressure (Inches of Water)																					
		0.10		0.20		0.30		0.40		0.50		0.60		0.70		0.80		0.90		1.00	
cfm	rpm	bhp	rpm	bhp	rpm	bhp	rpm	bhp	rpm	bhp	rpm	bhp	rpm	bhp	rpm	bhp	rpm	bhp	rpm	bhp	
7.5hp Standard motor & Field Supplied Drive ^(a)										7.5-hp Standard Motor & Low Static Drive Accessory											
7000	---	---	617	1.67	657	1.87	691	2.05	721	2.21	749	2.37	780	2.57	813	2.79	843	3.01	872	3.22	
7500	604	1.74	650	1.99	688	2.21	722	2.41	752	2.59	780	2.77	806	2.94	835	3.15	865	3.39	894	3.62	
8000	637	2.07	683	2.35	719	2.59	753	2.81	783	3.02	810	3.21	836	3.39	860	3.57	888	3.80	916	4.05	
8500	671	2.44	716	2.75	751	3.01	784	3.25	815	3.48	841	3.69	866	3.89	890	4.09	913	4.28	939	4.51	
9000	705	2.86	748	3.19	784	3.47	816	3.73	846	3.99	873	4.22	897	4.44	921	4.65	943	4.86	965	5.06	
9500	739	3.32	781	3.68	816	3.98	847	4.27	877	4.54	905	4.80	929	5.04	952	5.27	974	5.49	995	5.71	
10000	773	3.83	814	4.21	849	4.55	880	4.85	908	5.14	935	5.42	961	5.69	983	5.94	1005	6.17	1026	6.41	
10500	807	4.39	847	4.79	882	5.17	912	5.49	940	5.79	966	6.09	992	6.39	1015	6.66	1036	6.92	1057	7.17	
11000	842	5.01	880	5.43	915	5.83	945	6.18	972	6.51	998	6.83	1022	7.14	1046	7.44	1068	7.72	1088	7.98	
																	7.5-hp Standard Motor & High Static Drive Accessory				

Continued

External Static Pressure (Inches of Water)																					
		1.10		1.20		1.30		1.40		1.50		1.60		1.70		1.80		1.90		2.00	
cfm	rpm	bhp	rpm	bhp	rpm	bhp	rpm	bhp	rpm	bhp	rpm	bhp	rpm	bhp	rpm	bhp	rpm	bhp	rpm	bhp	
7.5-hp Standard Motor & Drive										7.5-hp Standard Motor & High Static Drive Accessory											
7000	900	3.44	927	3.65	953	3.86	978	4.07	1002	4.29	1025	4.51	1047	4.74	1069	4.96	1091	5.18	1112	5.41	
7500	922	3.86	948	4.09	974	4.32	999	4.54	1023	4.77	1046	4.99	1068	5.23	1090	5.46	1111	5.70	1132	5.94	
8000	944	4.30	970	4.55	995	4.80	1020	5.04	1044	5.29	1067	5.53	1089	5.77	1111	6.01	1133	6.25	1153	6.51	
8500	966	4.78	992	5.05	1017	5.31	1042	5.58	1065	5.84	1088	6.10	1110	6.36	1132	6.62	1153	6.87	1174	7.13	
9000	988	5.29	1014	5.58	1039	5.87	1063	6.15	1087	6.43	1110	6.71	1132	6.98	1153	7.26	1175	7.53	1195	7.81	
9500	1016	5.92	1037	6.15	1062	6.45	1086	6.75	1109	7.05	1131	7.35	1154	7.64	1175	7.94	1196	8.23	1216	8.52	
10000	1046	6.64	1066	6.87	1085	7.09	1108	7.40	1131	7.71	1154	8.03	1175	8.34	1197	8.66	1218	8.97	1238	9.28	
10500	1077	7.41	1096	7.66	1115	7.89	1133	8.13	1154	8.42	1176	8.75	1198	9.08	1219	9.41	1239	9.74	1260	10.07	
11000	1107	8.25	1126	8.51	1145	8.76	1163	9.01	1181	9.26	1198	9.51	1220	9.87	1241	10.22	1262	10.56	1282	10.91	
																	10-hp Oversized Motor & Drive				

Notes:

1. For Standard Evaporator Fan Speed (rpm), reference [Table 27, p. 42](#).
2. For High Evaporator Fan Speed (rpm), reference [Table 29, p. 42](#).
3. For Oversized Evaporator Fan Speed (rpm), reference [Table 30, p. 42](#).
4. Fan motor heat (MBh) = 3.15 x Fan bhp.
5. Data includes pressure drop due to standard filters and wet coils. No accessories or options are included in pressure drop data.
6. For all non-standard sheave combinations, please refer to accessory installer's guides ACC-SVN163*-EN and ACC-SVN169*-EN.
7. Factory supplied motors, in commercial equipment, are definite purpose motors, specifically designed and tested to operate reliably and continuously at all cataloged conditions. Using the full horsepower range of our fan motors as shown in our tabular data will not result in nuisance tripping or premature motor failure. Our product's warranty will not be affected.
8. For multi-speed fan operation, max allowable bhp is 10.0.

(a) Field supplied BK190 x 1.4375" fan sheave, 1VP44 x 1.125" motor sheave, and BX66 belt.



Performance Data

Table 25. Evaporator fan performance - 25 ton cooling only unit (model number digit 8 = K) - EBC300 - downflow airflow

External Static Pressure (Inches of Water)																					
		0.10		0.20		0.30		0.40		0.50		0.60		0.70		0.80		0.90		1.00	
cfm	rpm	bhp	rpm	bhp	rpm	bhp	rpm	bhp	rpm	bhp	rpm	bhp	rpm	bhp	rpm	bhp	rpm	bhp	rpm	bhp	
7.5-hp Standard Motor & Field Supplied Drive ^(a)											7.5-hp Standard Motor & Low Static Drive Accessory										
7000	---	---	---	---	601	1.56	640	1.74	676	1.91	708	2.07	738	2.24	766	2.39	792	2.54	818	2.69	
7500	---	---	586	1.63	627	1.83	665	2.03	700	2.22	732	2.39	762	2.57	789	2.74	816	2.91	841	3.07	
8000	---	---	614	1.92	653	2.14	690	2.35	724	2.55	756	2.75	786	2.94	813	3.13	839	3.31	864	3.49	
8500	599	1.99	642	2.24	680	2.48	716	2.70	749	2.92	781	3.14	810	3.34	838	3.54	863	3.74	888	3.94	
9000	629	2.33	670	2.60	707	2.85	742	3.09	775	3.33	805	3.56	834	3.79	862	4.00	888	4.21	912	4.43	
9500	659	2.71	698	2.99	735	3.26	769	3.52	800	3.77	830	4.02	859	4.26	886	4.50	912	4.73	937	4.95	
10000	689	3.13	727	3.42	763	3.72	796	3.99	826	4.25	856	4.52	884	4.78	911	5.03	936	5.28	961	5.52	
10500	720	3.59	756	3.90	791	4.21	823	4.50	853	4.78	881	5.06	909	5.34	935	5.61	961	5.87	985	6.13	
11000	750	4.10	786	4.42	819	4.75	850	5.06	880	5.36	908	5.65	934	5.94	960	6.23	985	6.51	1009	6.79	

Continued

External Static Pressure (Inches of Water)																					
		1.10		1.20		1.30		1.40		1.50		1.60		1.70		1.80		1.90		2.00	
cfm	rpm	bhp	rpm	bhp	rpm	bhp	rpm	bhp	rpm	bhp	rpm	bhp	rpm	bhp	rpm	bhp	rpm	bhp	rpm	bhp	
7.5-hp Standard Motor & Drive																					
7000	846	2.86	873	3.03	899	3.19	924	3.35	948	3.51	973	3.70	997	3.91	1021	4.12	1044	4.33	1067	4.55	
7500	865	3.23	890	3.41	916	3.59	941	3.77	965	3.94	988	4.11	1011	4.28	1034	4.47	1057	4.69	1079	4.92	
8000	888	3.67	911	3.84	933	4.01	958	4.20	982	4.39	1005	4.58	1028	4.77	1050	4.95	1071	5.14	1092	5.31	
8500	911	4.13	934	4.32	956	4.50	977	4.69	999	4.87	1022	5.08	1045	5.28	1067	5.48	1088	5.68	1109	5.88	
9000	935	4.63	958	4.84	979	5.04	1001	5.23	1021	5.43	1041	5.62	1062	5.83	1084	6.04	1105	6.26	1126	6.47	
9500	960	5.17	982	5.39	1003	5.61	1024	5.82	1044	6.03	1064	6.24	1083	6.44	1102	6.64	1122	6.86	1143	7.09	
10000	984	5.75	1006	5.99	1027	6.22	1048	6.45	1068	6.68	1087	6.90	1106	7.12	1125	7.34	1143	7.55	1161	7.76	
10500	1008	6.38	1031	6.63	1052	6.88	1072	7.12	1092	7.36	1111	7.60	1130	7.84	1148	8.07	1166	8.30	1184	8.53	
11000	1032	7.06	1055	7.32	1076	7.58	1096	7.84	1116	8.10	1135	8.35	1154	8.60	1172	8.85	1190	9.10	1207	9.34	

Notes:

1. For Standard Evaporator Fan Speed (rpm), reference [Table 27, p. 42](#).
2. For High Evaporator Fan Speed (rpm), reference [Table 29, p. 42](#).
3. Fan motor heat (MBh) = 3.15 x Fan bhp.
4. Data includes pressure drop due to standard filters and wet coils. No accessories or options are included in pressure drop data.
5. For all non-standard sheave combinations, please refer to accessory installer's guides ACC-SVN163*-EN and ACC-SVN169*-EN.
6. Factory supplied motors, in commercial equipment, are definite purpose motors, specifically designed and tested to operate reliably and continuously at all cataloged conditions. Using the full horsepower range of our fan motors as shown in our tabular data will not result in nuisance tripping or premature motor failure. Our product's warranty will not be affected.
7. For multi-speed fan operation, max allowable bhp is 10.0.

(a) Field supplied BK190 x 1.4375" fan sheave, 1VP44 x 1.125" motor sheave, and BX66 belt.

Performance Data

Table 26. Evaporator fan performance - 25 ton cooling only unit (model number digit 8 = K) - EBC300 - horizontal airflow

External Static Pressure (Inches of Water)																					
		0.10		0.20		0.30		0.40		0.50		0.60		0.70		0.80		0.90		1.00	
cfm	rpm	bhp	rpm	bhp	rpm	bhp	rpm	bhp	rpm	bhp	rpm	bhp	rpm	bhp	rpm	bhp	rpm	bhp	rpm	bhp	
7.5hp Standard motor & Field Supplied Drive										7.5-hp Standard Motor & Low Static Drive Accessory						7.5-hp Standard Motor & Drive					
7000	---	---	617	1.67	657	1.87	691	2.05	721	2.21	749	2.37	780	2.57	813	2.79	843	3.01	872	3.22	
7500	604	1.74	650	1.99	688	2.21	722	2.41	752	2.59	780	2.77	806	2.94	835	3.15	865	3.39	894	3.62	
8000	637	2.07	683	2.35	719	2.59	753	2.81	783	3.02	810	3.21	836	3.39	860	3.57	888	3.80	916	4.05	
8500	671	2.44	716	2.75	751	3.01	784	3.25	815	3.48	841	3.69	866	3.89	890	4.09	913	4.28	939	4.51	
9000	705	2.86	748	3.19	784	3.47	816	3.73	846	3.99	873	4.22	897	4.44	921	4.65	943	4.86	965	5.06	
9500	739	3.32	781	3.68	816	3.98	847	4.27	877	4.54	905	4.80	929	5.04	952	5.27	974	5.49	995	5.71	
10000	773	3.83	814	4.21	849	4.55	880	4.85	908	5.14	935	5.42	961	5.69	983	5.94	1005	6.17	1026	6.41	
10500	807	4.39	847	4.79	882	5.17	912	5.49	940	5.79	966	6.09	992	6.39	1015	6.66	1036	6.92	1057	7.17	
11000	842	5.01	880	5.43	915	5.83	945	6.18	972	6.51	998	6.83	1022	7.14	1046	7.44	1068	7.72	1088	7.98	
																		7.5-hp Std Motor & HS Drive Accessory			

Continued

External Static Pressure (Inches of Water)																					
		1.10		1.20		1.30		1.40		1.50		1.60		1.70		1.80		1.90		2.00	
cfm	rpm	bhp	rpm	bhp	rpm	bhp	rpm	bhp	rpm	bhp	rpm	bhp	rpm	bhp	rpm	bhp	rpm	bhp	rpm	bhp	
7.5-hp Standard Motor & Drive												7.5-hp Std Motor & HS Drive Accessory									
7000	900	3.44	927	3.65	953	3.86	978	4.07	1002	4.29	1025	4.51	1047	4.74	1069	4.96	1091	5.18	1112	5.41	
7500	922	3.86	948	4.09	974	4.32	999	4.54	1023	4.77	1046	4.99	1068	5.23	1090	5.46	1111	5.70	1132	5.94	
8000	944	4.30	970	4.55	995	4.80	1020	5.04	1044	5.29	1067	5.53	1089	5.77	1111	6.01	1133	6.25	1153	6.51	
8500	966	4.78	992	5.05	1017	5.31	1042	5.58	1065	5.84	1088	6.10	1110	6.36	1132	6.62	1153	6.87	1174	7.13	
9000	988	5.29	1014	5.58	1039	5.87	1063	6.15	1087	6.43	1110	6.71	1132	6.98	1153	7.26	1175	7.53	1195	7.81	
9500	1016	5.92	1037	6.15	1062	6.45	1086	6.75	1109	7.05	1131	7.35	1154	7.64	1175	7.94	1196	8.23	---	---	
10000	1046	6.64	1066	6.87	1085	7.09	1108	7.40	1131	7.71	1154	8.03	1175	8.34	1197	8.66	---	---	---	---	
10500	1077	7.41	1096	7.66	1115	7.89	1133	8.13	1154	8.42	1176	8.75	1198	9.08	---	---	---	---	---	---	
11000	1107	8.25	1126	8.51	1145	8.76	1163	9.01	1181	9.26	1198	9.51	---	---	---	---	---	---	---	---	

Notes:

1. For Standard Evaporator Fan Speed (rpm), reference [Table 27, p. 42](#).
2. For High Evaporator Fan Speed (rpm), reference [Table 29, p. 42](#).
3. Fan motor heat (MBh) = 3.15 x Fan bhp.
4. Data includes pressure drop due to standard filters and wet coils. No accessories or options are included in pressure drop data.
5. For all non-standard sheave combinations, please refer to accessory installer's guides ACC-SVN163*-EN and ACC-SVN169*-EN.
6. Factory supplied motors, in commercial equipment, are definite purpose motors, specifically designed and tested to operate reliably and continuously at all cataloged conditions. Using the full horsepower range of our fan motors as shown in our tabular data will not result in nuisance tripping or premature motor failure. Our product's warranty will not be affected.
7. For multi-speed fan operation, max allowable bhp is 10.0.



Performance Data

Table 27. Standard motor and drive/fan speed (rpm)

Tons	Unit Model Number	6 Turns Open	5 Turns Open	4 Turns Open	3 Turns Open	2 Turns Open	1 Turn Open	Closed
15	E/G*C180A3,4,W	639	686	733	781	828	875	N/A
15	E*C180AK	668	712	757	801	846	890	N/A
17½	E*C210A3,4,W,K G*C210A3,4,W	695	747	798	850	901	953	N/A
20	G*C240A3,4,W	798	850	901	953	1004	1056	N/A
20	E*C240A3,4,W,K	695	747	798	850	901	953	N/A
25	G*C300A3,4,W	953	1004	1056	1107	1159	1210	N/A
25	E*C300A3,4,W	829	874	919	963	1008	1053	N/A
25	E*C300AK	699	751	803	854	906	958	N/A

Note: Factory set at 3 turns open.

Table 28. Standard motor and low static drive accessory sheave / fan speed (rpm)

Tons	Unit Model Number	6 Turns Open	5 Turns Open	4 Turns Open	3 Turns Open	2 Turns Open	1 Turn Open	Closed
15	E/G*C180A3,4,W	477	512	548	583	619	654	N/A
15	E*C180AK	506	544	581	619	656	694	N/A
17½	E*C210A3,4,W,K G*C210A3,4,W	538	574	610	645	681	717	N/A
20	G*C240A3,4,W	605	650	695	739	784	829	N/A
20	E*C240A3,4,W,K	538	574	610	645	681	717	N/A
25	G*C300A3,4,W	798	849	901	952	1004	1056	N/A
25	E*C300A3,4,W,K	694	739	784	829	874	919	N/A

Table 29. Standard motor and high static drive accessory sheave / fan speed (rpm)

Tons	Unit Model Number	6 Turns Open	5 Turns Open	4 Turns Open	3 Turns Open	2 Turns Open	1 Turn Open	Closed
15	E/G*C180A3,4,W	875	922	969	1017	1064	1111	N/A
15	E*C180AK	817	878	938	999	1059	1120	N/A
17½	E*C210A3,4,W,K G*C210A3,4,W	953	1004	1056	1107	1159	1210	N/A
20	E*C240A3,4,W,K G*C240A3,4,W	863	919	974	1030	1085	1141	N/A
25	E*C300A3,4,W,K	953	1004	1056	1107	1159	1210	N/A

Table 30. Oversized motor and drive/fan speed (rpm)

Tons	Unit Model Number	6 Turns Open	5 Turns Open	4 Turns Open	3 Turns Open	2 Turns Open	1 Turn Open	Closed
15	E/G*C180A3,4,W	817	878	938	999	1059	1120	N/A
17½	E*C210A3,4,W,K G*C210A3,4,W	953	1004	1056	1107	1159	1210	N/A
20	E*C240A3,4,W,K G*C240A3,4,W	953	1004	1056	1107	1159	1210	N/A
25	E/G*C300A3,4,W	1096	1138	1181	1223	1266	1308	N/A

Table 31. Static pressure drop through accessories (inches water column)

Tons	Unit Model Number	cfm	2" Standard Filters	2" MERV 13 Filters	Standard Economizer with OA/RA Dampers ^(a)		Low Leak Economizer with OA/RA Dampers ^(a)		Electric Heater Accessory (kW) ^(b)			
					100% OA	100% RA	100% OA	100% RA	18	36	54	72
					15	E/G*C180A (Downflow)	4800	0.03	0.10	0.15	0.04	0.19
		6000	0.05	0.14	0.20	0.04	0.31	0.34	0.02	0.02	-	-
		7200	0.07	0.17	0.27	0.04	0.45	0.48	0.03	0.03	-	-
	E/G*C180A (Horizontal)	4800	0.03	0.10	0.15	0.04	0.19	0.22	0.01	0.01	-	-
		6000	0.05	0.14	0.20	0.04	0.31	0.34	0.02	0.02	-	-
		7200	0.07	0.17	0.27	0.04	0.45	0.48	0.04	0.04	-	-
17½	E/G*C210A (Downflow)	5600	0.05	0.12	0.18	0.04	0.27	0.29	-	0.03	0.04	0.04
		7000	0.07	0.16	0.26	0.04	0.42	0.46	-	0.05	0.05	0.06
		8400	0.10	0.20	0.35	0.06	0.61	0.66	-	0.06	0.07	0.09
	E/G*C210A (Horizontal)	5600	0.05	0.12	0.18	0.04	0.27	0.29	-	0.03	0.04	0.04
		7000	0.07	0.16	0.26	0.04	0.42	0.46	-	0.05	0.06	0.07
		8400	0.10	0.20	0.35	0.06	0.61	0.66	-	0.07	0.09	0.11
20	E/G*C240A (Downflow)	6400	0.06	0.15	0.22	0.04	0.35	0.38	-	0.04	0.05	0.05
		8000	0.09	0.19	0.32	0.05	0.55	0.60	-	0.05	0.07	0.08
		9600	0.13	0.24	0.44	0.07	0.81	0.86	-	0.06	0.08	0.11
	E/G*C240A (Horizontal)	6400	0.06	0.15	0.22	0.04	0.35	0.38	-	0.04	0.05	0.06
		8000	0.09	0.19	0.32	0.05	0.55	0.60	-	0.07	0.08	0.10
		9600	0.13	0.24	0.44	0.07	0.81	0.86	-	0.09	0.11	0.14
25	E/G*C300A (Downflow)	7000	0.07	0.16	0.26	0.04	0.42	0.46	-	0.05	0.05	0.06
		9000	0.10	0.22	0.40	0.07	0.71	0.75	-	0.06	0.08	0.10
		11000	0.17	0.28	0.57	0.10	1.07	1.12	-	0.07	0.10	0.12
	E/G*C300A (Horizontal)	7000	0.07	0.16	0.26	0.04	0.42	0.46	-	0.05	0.06	0.07
		9000	0.10	0.22	0.40	0.07	0.71	0.75	-	0.08	0.10	0.12
		11000	0.17	0.28	0.57	0.10	1.07	1.12	-	0.13	0.18	0.23

(a) OA = Outside Air and RA = Return Air.

(b) Nominal kW ratings at 240, 480, 600 volts.

Table 32. Gas fired heating capacities

Tons	Unit Model Number	Heating Input (MBH) ^(a)	Heating Output (MBH) ^(a)	Air Temp Rise (F)
15	G*C180A(3,4,W)E(L or X)	240/168	192/134	10 - 40
	G*C180A(3,4,W)E(M or Y)	320/224	256/179	20 - 50
	G*C180A(3,4,W)E(H or Z)	350/245	280/196	25 - 55
17.5	G*C210A(3,4,W)E(L or X)	240/168	192/134	10 - 40
	G*C210A(3,4,W)E(M or Y)	320/224	256/179	20 - 50
	G*C210A(3,4,W)E(H or Z)	400/280	320/224	25 - 55
20	G*C240A(3,4,W)E(L or X)	240/168	192/134	10 - 40
	G*C240A(3,4,W)E(M or Y)	320/224	256/179	20 - 50
	G*C240A(3,4,W)E(H or Z)	400/280	320/224	25 - 55
25	G*C300A(3,4,W)E(L or X)	240/168	192/134	10 - 40
	G*C300A(3,4,W)E(M or Y)	320/224	256/179	20 - 50
	G*C300A(3,4,W)E(H or Z)	400/280	320/224	25 - 55

(a) For two stage heaters (input or output), second stage is total heating capacity. Second stage/first stage.



Performance Data

Table 33. Auxiliary electric heat capacity

Tons	Unit Model Number.	Total ^(a)		No. of Stages	Stage1		Stage 2	
		kW Input ^(b)	MBh Output		kW Input	MBh Output	kW Input	MBh Output
15	E*C180A3,4,W,K	18	61.5	1	18	61.5	—	—
		36	122.9	2	18	61.5	18	61.5
		54	184.4	2	36	122.9	18	61.5
17½–25	E*C210A3,4,W,K E*C240A3,4,W,K E*C300A3,4,W,K	36	122.9	2	18	61.5	18	61.5
		54	184.4	2	36	122.9	18	61.5
		72	245.9	2	36	122.9	36	122.9

(a) Heaters are rated at 240V, 480V, and 600V. For other than rated voltage, CAP = (voltage/rated voltage)² x rated cap.
 (b) For all input/output categories, does not include fan power or heat.

Table 34. Electric heater voltage correction factors (applicable to auxiliary heat capacity)

Nominal Voltage	Distribution Voltage	Capacity Multiplier
240	208	0.75
	230	0.92
	240	1.00
480	380	0.63
	440	0.84
	460	0.94
	480	1.00
600	540	0.81
	575	0.92
	600	1.00

Table 35. Air temperature rise across electric heaters (°F)

kW	Stages	15 Tons 6000 cfm E*C180A	17½ Tons 7000 cfm E*C210A	20 Tons 8000 cfm E*C240A	25 Ton 9000 cfm E*C300A
18	1	9.5	—	—	—
36	2	19.0	16.3	14.2	12.6
54	2	28.5	24.4	21.3	19.0
72	2	—	32.5	28.5	25.3

Note: For minimum design airflow, see airflow performance table for each unit. To calculate temp rise at different airflow, use the following formula:
 Temp. rise across Electric Heater = kW x 3414/1.08 x cfm.



Controls

Economizer Controls

The standard equipment offering is a fixed dry bulb changeover control. In addition, there are two optional controls, Reference Enthalpy Control and Comparative Enthalpy Control.

Reference Enthalpy Control

Replaces the dry bulb control with a wet bulb changeover controller which has a fully adjustable setpoint. Enthalpy control offers a higher level of comfort control, along with energy savings potential, than the standard dry bulb control. This is due to the additional wet bulb sensing capability.

Comparative Enthalpy Control

Comparative Enthalpy replaces the standard dry bulb control with two sensors that compare total heat content of the indoor air and outdoor air to determine the most efficient air source. This control option offers the highest level of comfort control, plus energy efficiency, available.

Remote Potentiometer

Minimum position setting of economizer can be remotely adjusted with this accessory.

Thermostats

Table 36. Thermostats

Model #	Type	Stages	Display Type	Other
TCONT302AS42DA	Programmable	4H/2C	Touchscreen	Common preferred, not required 2/ 2 AA battery power
TCONT402AN32DA	Non-Programmable	3H/2C	Backlit Display and Keys	Outdoor Temperature Sensor included
BAYSTAT814	Touchscreen	3H/2C	Touchscreen	Remote access via Pivot Mobile App
BAYSTAT300	Programmable	3H/2C	Backlit Display and Keys	BACnet MS-TP enabled



Electrical Data

Table 37. Unit wiring with cooling (no electric heat) or gas heat

Tons	Unit Model Number	Unit Operating Voltage Range	Standard Indoor Fan Motor		Oversized Indoor Fan Motor	
			Minimum Circuit Ampacity ^(a)	Maximum Fuse Size or Maximum Circuit Breaker	Minimum Circuit Ampacity	Maximum Fuse Size or Maximum Circuit Breaker
15	E/GBC180A3	208-230	79	100	85	110
	E/GBC180A4	460	36	45	39	50
	E/GBC180AW	575	30	35	32	40
	EBC180AK	380 ^(b)	48	60	-	-
17½	E/GBC210A3	208-230	92	110	99	125
	E/GBC210A4	460	40	50	44	50
	E/GBC210AW	575	33	40	36	45
	EBC210AK	380 ^(b)	52	60	56	70
20	E/GBC240A3	208-230	101	125	109	125
	E/GBC240A4	460	50	60	53	60
	E/GBC240AW	575	39	50	42	50
	EBC240AK	380 ^(b)	61	80	65	80
25	E/GBC300A3	208-230	133	175	140	175
	E/GBC300A4	460	58	70	61	70
	E/GBC300AW	575	46	60	48	60
	EBC300AK	380 ^(b)	73	90	-	-

(a) For Standard and Oversized Indoor Fan Motor, values do not include power exhaust accessory.

(b) Unit will operate reliably at 400VAC.

Table 38. Unit wiring with electric heat (single point connection)

Tons	Unit Model Number	Heater Model Number	Heater kW Rating	Control Stages	Standard Indoor Motor		Oversized Indoor Motor	
					MCA	Max Fuse Size or Max Circuit Breaker	MCA	Max Fuse Size or Max Circuit Breaker ^(a)
208/230 Volts Three Phase								
15	EBC180A3	BAYHTFB318A	13.5/18	1	79	100	85	110
		BAYHTFC336A	27/36	2	108/122	110/125	115/130	125/150
		BAYHTFC354A	40.5/54	2	155/144	175	162/151	175
17½	EBC210A3	BAYHTFC336A	27/36	2	115/130	125/150	125/139	125/150
		BAYHTFC354A	40.5/54	2	162/151	175	172/161	175
		BAYHTFC372A	54/72	2	172/195	200/225	181/204	200/225
20	EBC240A3	BAYHTFD336A	27/36	2	115/130	125/150	125/139	125/150
		BAYHTFD354A	40.5/54	2	162/151	175	172/161	175
		BAYHTFD372A	54/72	2	172/195	200/225	181/204	200/225
25	EBC300A3	BAYHTFD336A	27/36	2	133/139	175	140/147	175
		BAYHTFD354A	40.5/54	2	172/161	175	180/169	200/175
		BAYHTFD372A	54/72	2	181/204	200/225	189/212	200/225

Table 38. Unit wiring with electric heat (single point connection) (continued)

Tons	Unit Model Number	Heater Model Number	Heater kW Rating	Control Stages	Standard Indoor Motor		Oversized Indoor Motor	
					MCA	Max Fuse Size or Max Circuit Breaker	MCA	Max Fuse Size or Max Circuit Breaker ^(a)
460 Volts Three Phase								
15	EBC180A4	BAYHTFB418A	18	1	36	45	39	50
		BAYHTFC436A	36	2	61	70	64	70
		BAYHTFC454A	54	2	72	90	75	90
17½	EBC210A4	BAYHTFC436A	36	2	64	70	68	70
		BAYHTFC454A	54	2	75	90	79	90
		BAYHTFC472A	72	2	97	110	101	110
20	EBC240F4	BAYHTFD436A	36	2	64	70	68	70
		BAYHTFD454A	54	2	75	90	79	90
		BAYHTFD472A	72	2	97	110	101	110
25	EBC300A4	BAYHTFD436A	36	2	68	70	72	80
		BAYHTFD454A	54	2	79	90	83	90
		BAYHTFD472A	72	2	101	110	105	110
575 Volts Three Phase								
15	EBC180AW	BAYHTFBW18A	18	1	30	35	32	40
		BAYHTFCW36A	36	2	49	50	51	60
		BAYHTFCW54A	54	2	57	70	60	70
17½	EBC210AW	BAYHTFCW36A	36	2	51	60	55	60
		BAYHTFCW54A	54	2	60	70	64	70
		BAYHTFCW72A	72	2	77	90	81	90
20	EBC240AW	BAYHTFDW36A	36	2	51	60	55	60
		BAYHTFDW54A	54	2	60	70	64	70
		BAYHTFDW72A	72	2	77	90	81	90
25	EBC300AW	BAYHTFDW36A	36	2	55	60	58	60
		BAYHTFDW54A	54	2	64	70	66	70
		BAYHTFDW72A	72	2	81	90	84	90
380 Volts Three Phase^(b)								
15	EBC180AK	BAYHTFBK18A	11.3	1	48	60	-	-
		BAYHTFCK36A	22.6	2	55	60	-	-
		BAYHTFCK54A	33.8	2	76	80	-	-
17½	EBC210AK	BAYHTFCK36A	22.6	2	55	60	60	60
		BAYHTFCK54A	33.8	2	76	80	81	90
		BAYHTFCK72A	45.1	2	98	100	103	110
20	EBC240AK	BAYHTFDK36A	22.6	2	61	70	65	80
		BAYHTFDK54A	33.8	2	76	80	81	90
		BAYHTFDK72A	45.1	2	98	100	103	110
25	EBC300AK	BAYHTFDK36A	22.6	2	73	90	-	-
		BAYHTFDK54A	33.8	2	81	90	-	-
		BAYHTFDK72A	45.1	2	103	110	-	-

(a) Values do not include power exhaust accessory.
 (b) Unit will operate reliably at 400VAC.



Electrical Data

Table 39. Electrical characteristics—compressor motor and condenser motor

Tons	Unit Model No.	Compressor Motors						Condenser Fan Motors				
		No.	Volts	Phase	rpm	Amps ^(a)		No.	Phase	hp	Amps ^(a)	
						RLA	LRA				FLA	LRA
15	E/GBC180A3	2	280–230	3	3500	26.9/24.9	208/180	2	3	1	4.8	20.0
	E/GBC180A4	2	460	3	3500	12.1/10.8	98/75	2	3	1	2.5	10.1
	E/GBC180AW	2	575	3	3500	10.1/8.8	75/60	2	3	1	1.9	8.0
	EBC180AK	2	380 ^(b)	3	3500	14.8/13.5	117/91	2	3	1	3.1	12.6
17½	E/GBC210A3	2	280–230	3	3500	28.9/28.9	208/208	2	3	1	4.8	20.0
	E/GBC210A4	2	460	3	3500	12.1/12.1	98/98	2	3	1	2.5	10.1
	E/GBC210AW	2	575	3	3500	10.1/10.1	75/75	2	3	1	1.9	8.0
	EBC210AK	2	380 ^(b)	3	3500	16.2/16.2	117/117	2	3	1	3.1	12.6
20	E/GBC240A3	3	280–230	3	3500	35.7/29.6	240/240	2	3	1	4.8	20.0
	E/GBC240A4	3	460	3	3500	16.8/15.5	140/130	2	3	1	2.5	10.1
	E/GBC240AW	3	575	3	3500	13.6/11.8	107.6/93.7	2	3	1	1.9	8.0
	EBC240AK	3	380 ^(b)	3	3500	22.3/16.8	152/135	2	3	1	3.1	12.6
25	E/GBC300A3	3	280–230	3	3500	50.5/35.7	245/240	2	3	1	4.8	20.0
	E/GBC300A4	3	460	3	3500	19.5/16.8	125/140	2	3	1	2.5	10.1
	E/GBC300AW	3	575	3	3500	15.5/13.6	100/107.6	2	3	1	1.9	8.0
	EBC300AK	3	380 ^(b)	3	3500	24.9/22.3	145/152	2	3	1	3.1	12.6

(a) For Compressor Motors and Condenser Fan Motors: Amp draw for each motor; multiply value by number of motors to determine total amps.

(b) Unit will operate reliably at 400VAC.

Table 40. Electrical characteristics—evaporator fan motor

Tons	Unit Model Number	Standard Evaporator Fan Motor						Oversized Evaporator Fan Motor					
		No.	Volts	Phase	hp	Amps		No.	Volts	Phase	hp	Amps	
						FLA	LRA					FLA	LRA
15	E/GBC180A3	1	208–230	3	3.00	10.6	83.0	1	208–230	3	5	16.7	110
	E/GBC180A4	1	460	3	3.00	4.8	35.5	1	460	3	5	7.6	56
	E/GBC180AW	1	575	3	3.00	3.9	31.0	1	575	3	5	6.1	44
	EBC180AK	1	380 ^(a)	3	5.00	9.2	66.5	1	-	-	-	-	-
17½	E/GBC210A3	1	208–230	3	5.00	16.7	110	1	208–230	3	7.5	24.2	150
	E/GBC210A4	1	460	3	5.00	7.6	56	1	460	3	7.5	11	75
	E/GBC210AW	1	575	3	5.00	6.1	44	1	575	3	7.5	9	60
	EBC210AK	1	380 ^(a)	3	5.00	9.2	66.5	1	380	3	7.5	13.3	76
20	E/GBC240A3	1	208–230	3	5.00	16.7	110	1	208–230	3	7.5	24.2	150
	E/GBC240A4	1	460	3	5.00	7.6	56	1	460	3	7.5	11	75
	E/GBC240AW	1	575	3	5.00	6.1	44	1	575	3	7.5	9	60
	EBC240AK	1	380 ^(a)	3	5.00	9.2	66.5	1	380	3	7.5	13.3	76
25	E/GBC300A3	1	208–230	3	7.50	24.2	150	1	208–230	3	10	30.8	227.2
	E/GBC300A4	1	460	3	7.50	11.0	75	1	460	3	10	14	113.6
	E/GBC300AW	1	575	3	7.50	9.0	60	1	575	3	10	11	90.8
	EBC300AK	1	380 ^(a)	3	7.50	13.3	76	1	-	-	-	-	-

(a) Unit will operate reliably at 400VAC.

Table 41. Electrical characteristics—combustion blower motor (gas heat units)

Unit Model Number	Heat	Heating Stages	hp	rpm ^(a)	Volts	Phase	Amps	
							FLA	LRA
GBC180A,210A,240A,300A	Low	2	1/15	3350/2800	208–230	1	0.36	0.72
GBC180A,210A,240A,300A	Med/High	2	1/6	3300/2300	208-230	1	0.95	1.41

(a) High/Low Speed.

Table 42. Electrical characteristics—power exhaust

Tons	Volts	Phase	hp	rpm	Amps	
					FLA	LRA
15–25	208–230	1	3/4	1040	6.6	13.5
	460	1	3/4	1040	3.2	8.4
	575	1	3/4	1040	2.1	5.2

Jobsite Connections

Table 43. Typical number of wires

Thermostats

B 3 Power Wires + 1 Ground Wire (three phase)

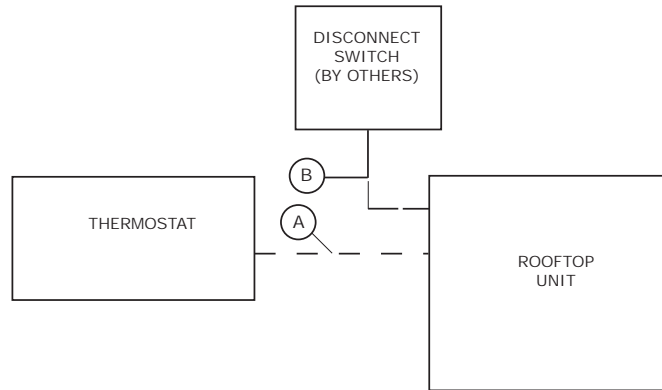

Notes:

- For specific wiring information, see the installation instructions.
- All wiring except power wire is low voltage.
- All customer supplied wiring to be copper and must conform to applicable electrical codes and local electric codes. Wiring shown dotted is to be furnished and installed by the customer.

Dimensional Data

Figure 1. Cooling with optional electrical heat and gas/electric units — overview

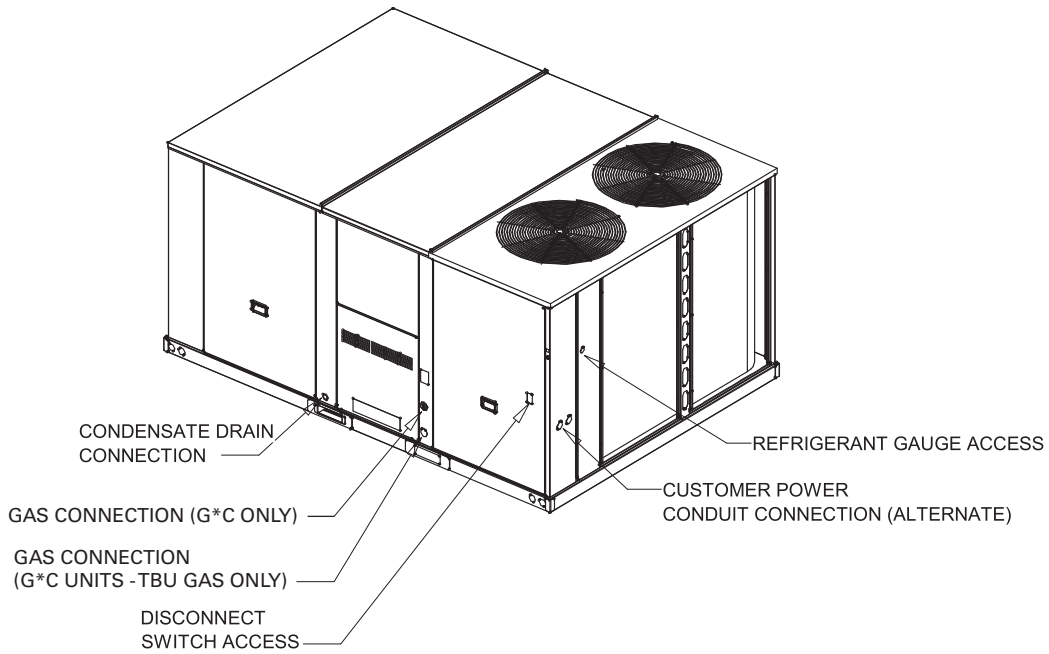
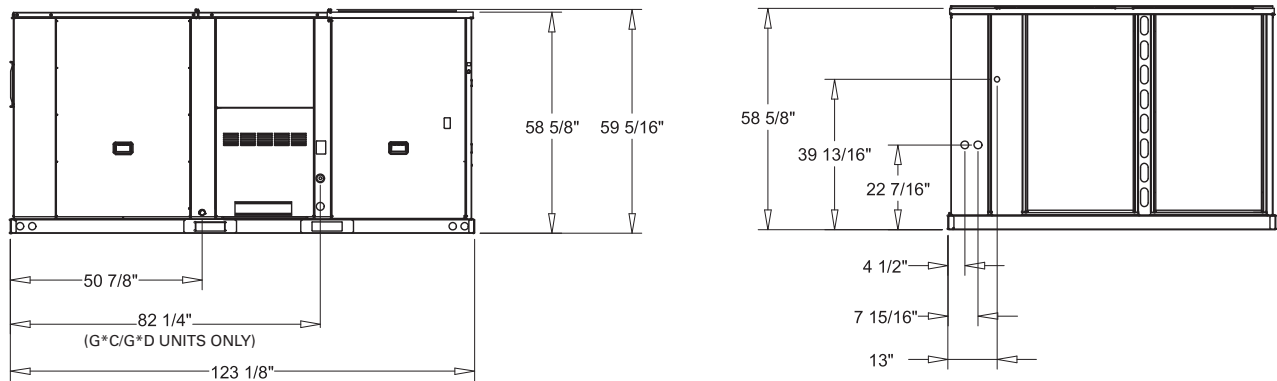

Figure 2. Cooling with optional electrical heat and gas/electric units — front & side views — 15–25 tons



- NOTES:
1. THRU -THE -BASE GAS AND ELECTRICAL IS NOT STANDARD ON ALL UNITS.
 2. VERIFY WEIGHT, CONNECTION, AND ALL DIMENSION WITH INSTALLER DOCUMENTS BEFORE INSTALLATION

Dimensional Data

Figure 3. Cooling with optional electrical heat and gas/electric units — plan view — 15–25 tons

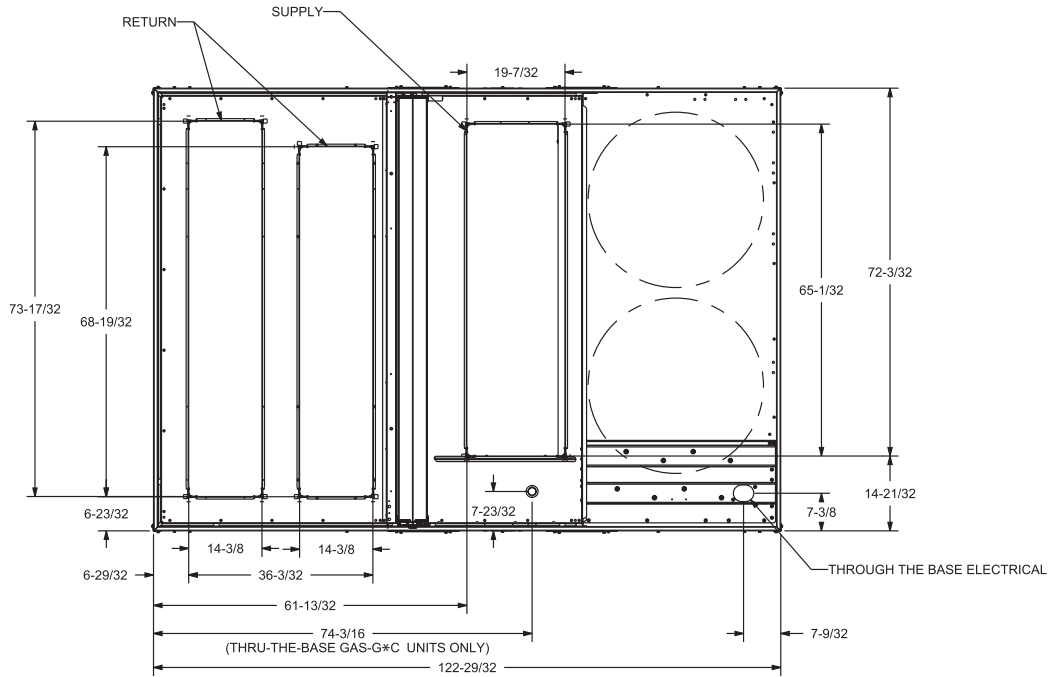

- NOTES:
1. THRU-THE-BASE GAS AND ELECTRICAL PROVISIONS ARE STANDARD ON ALL UNITS.
 2. VERIFY WEIGHT, CONNECTIONS, AND ALL OTHER DIMENSION WITH INSTALLER DOCUMENTS BEFORE INSULATION.

Figure 4. Cooling with optional electrical heat and gas/electric units — back view (horizontal configuration) — 15–25 tons

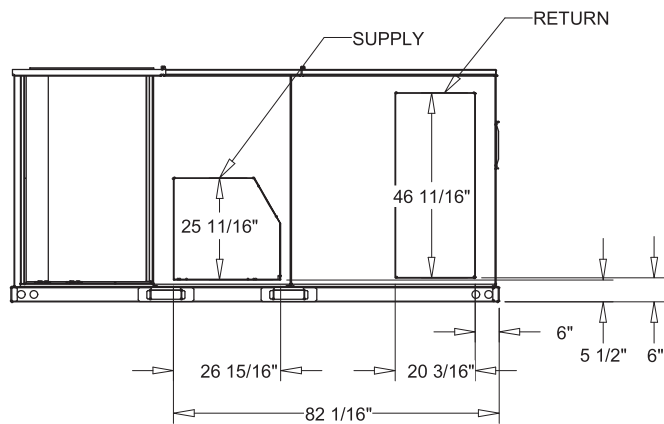

Figure 5. Cooling with optional electric heat and gas/electric models — roof curb — 15–25 tons

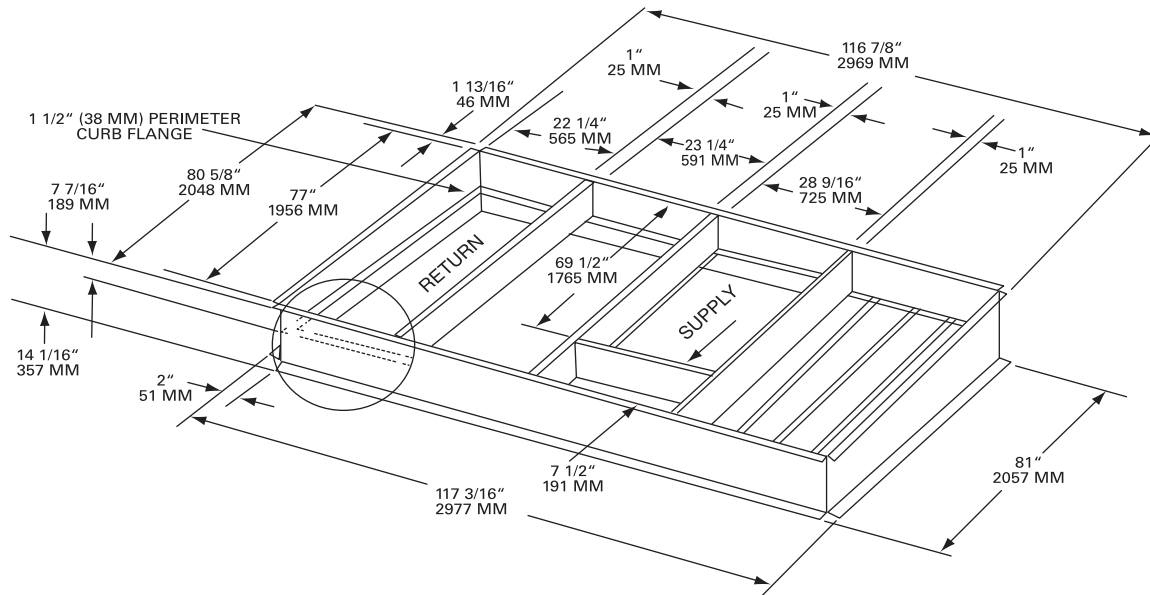
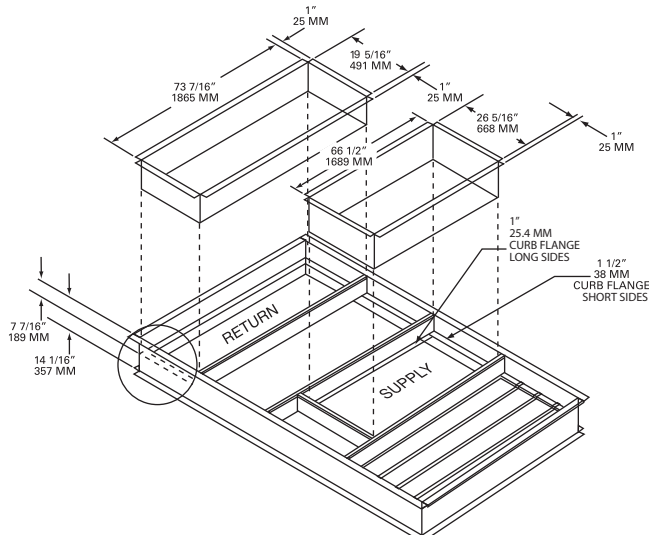

Figure 6. Cooling with optional electric heat and gas/electric models — downflow duct connections—field fabricated 15–25 tons



Notes:

- Duct flanges mount 7-7/16 inches down inside the curb on the 1-1/2 inches curb flanges.
- Roofcurb is intended for downflow use only.

Dimensional Data

Figure 7. Cooling with optional electric heat and gas/electric models — downflow unit clearance — 15–25 tons

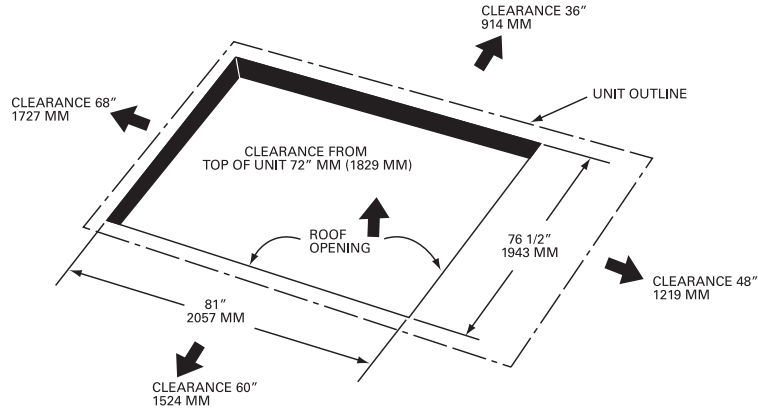
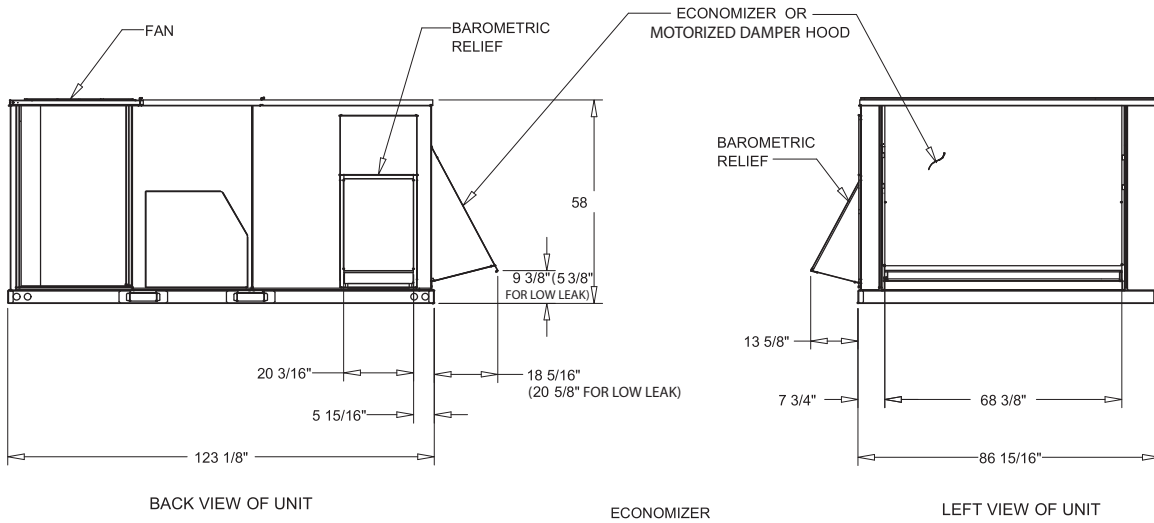

Figure 8. Cooling with optional electric heat and gas/electric models — barometric relief and economizer — 15–25 tons



NOTES:

1. VERIFY WEIGHT, CONNECTION, AND ALL DIMENSION WITH INSTALLER DOCUMENTS BEFORE INSTALLATION
2. BAROMETRIC RELIEF IS FOR USE WITH A DOWNFLOW ECONOMIZER ONLY

Figure 9. Cooling with optional electric heat and gas/electric models — manual damper — 15–25 tons

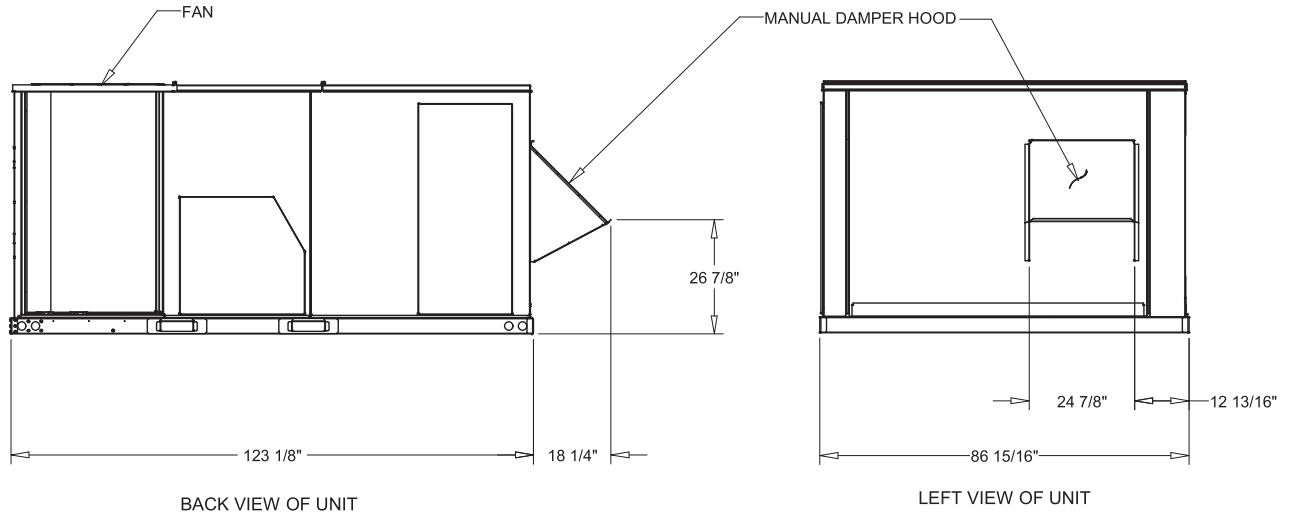

NOTE:
 1. VERIFY WEIGHT, CONNECTION, AND ALL DIMENSION WITH INSTALLER DOCUMENTS BEFORE INSTALLATION

Weights

Table 44. Maximum unit and corner weights (lb) and center of gravity dimensions (in.) cooling with optional electric heat units only

Tons	Unit Model No.	Weights (lb) ^{(a), (b)}		Corner Weights ^(c)				Center of Gravity (in.)	
		Shipping	Net	A	B	C	D	Length	Width
15	EBC180A	2160	1840	635	475	365	365	56	35
17½	EBC210A	2165	1845	634	477	367	367	56	35
20	EBC240A	2180	1860	632	484	372	372	55	37
25	EBC300A	2206	1886	641	490	377	377	55	36

(a) Weights are approximate. Horizontal and downflow unit and corner weights may vary slightly.

(b) Weights do not include additional factory or field installed options/accessories. For option/accessory additional weights, reference [Table 46, p. 57](#) to be added to unit weights.

(c) Corner weights are given for information only. 15–25 ton models must be supported continuously by a curb or equivalent frame support.

Table 45. Maximum unit and corner weights (lb) and center of gravity dimensions (in.) gas/electric heat units only

Tons	Unit Model No.	Weights (lb) ^{(a), (b)}		Corner Weights ^(c)				Center of Gravity (in.)	
		Shipping	Net	A	B	C	D	Length	Width
15	GBC180A	2324	2003	646	505	396	457	55	37
17½	GBC210A	2329	2009	647	506	395	460	55	37
20	GBC240A	2344	2024	643	512	403	466	55	37
25	GBC300A	2370	2050	668	521	391	470	55	36

(a) Weights are approximate. Horizontal and downflow unit and corner weights may vary slightly.

(b) Weights do not include additional factory or field installed options/accessories. For option/accessory additional weights, reference [Table 46, p. 57](#) to be added to unit weights.

(c) Corner weights are given for information only. 15–25 ton models must be supported continuously by a curb or equivalent frame support.

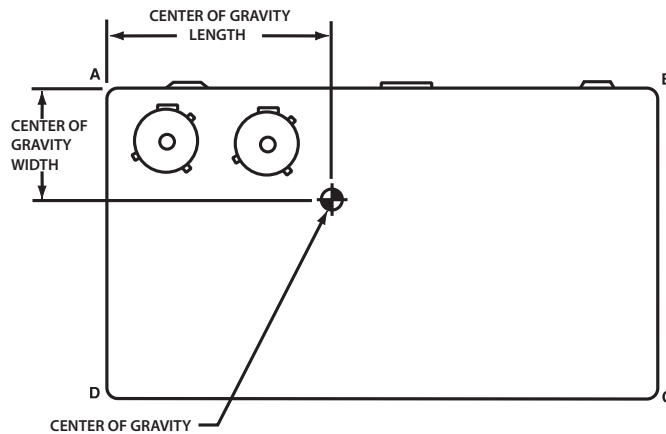

Table 46. Accessory net weight (lb)^{(a), (b)}

Accessories	E/GBC180	E/GBC210	E/GBC240	E/GBC300
Standard Economizer	91	91	91	91
Low Leak Economizer - Downflow	105	105	105	105
Low Leak Economizer - Horizontal	115	115	115	115
Manual Outside Air Damper	15	15	15	15
Motorized outside Air Damper ^(c)	82	82	82	82
Power Exhaust ^(c)	110	110	110	110
Barometric relief ^(c)	40	40	40	40
Roof Curb ^(c)	235	235	235	235
Oversized Motor				
5 HP	2	--	--	--
7.5 HP	--	20	20	--
10 HP ^(d)	--	--	--	60
Hail Guard	43	43	43	43
Through the Base Electrical	22	22	22	22
Disconnect	5	5	5	5
High Static Drive Kit ^(e)	2	2	2	2
Low Static Drive Kit ^(e)	2	2	2	2
LP Gas Conversion	2	2	2	2
Electric Heaters ^{(f), (g)}				
18 KW (230 / 460 & 575V)	36 / 29	--	--	--
36 KW (230 / 460 & 575V)	41 / 35	41 / 35	41 / 35	41 / 35
54 KW (230 / 460 & 575V)	48 / 40	48 / 40	48 / 40	48 / 40
72 KW (230 / 460 & 575V)	--	51 / 42	51 / 42	51 / 42
Multi-Speed w/ VFD				
3 & 5 HP	35	35	35	--
7.5 HP	--	65	65	65
10 HP	--	--	--	40

(a) Net weight should be added to unit weight when ordering factory-installed accessories.

(b) Weights for factory installed options and field installed accessories not listed are < 5 lb.

(c) Downflow only.

(d) 10.0 hp oversized motor is not available on 380V units.

(e) Not available on all models (see Fan Performance tables for specific models).

(f) For 600V heaters net weights are same as 480V heaters.

(g) To estimate shipping weight add 5 lb to net weight.



Mechanical Specifications

General

The units shall be dedicated downflow or horizontal airflow. The operating range shall be between 125°F and 40°F in cooling as standard from the factory for all units. All units shall be factory assembled, internally wired, fully charged with R-410A, and 100 percent run tested to check cooling operation, fan and blower rotation and control sequence, before leaving the factory. Wiring internal to the unit shall be colored and numbered for simplified identification. Units shall be UL listed and labeled, classified in accordance to UL 1995/C 22.2, 236-15 5th Edition.

Cooling capacities and efficiencies for Unitary Air-Cooled Packaged Air-conditioners are rated within the scope of the Air-Conditioning, Heating & Refrigeration Institute (AHRI) Certification Program and display the AHRI Certified® mark as a visual confirmation of conformance to the certification sections of AHRI Standard 340-360 (I-P) and ANSIZ21.47 and 10 CFR Part 431 pertaining to Commercial Warm Air Furnaces.

Casing

Unit casing shall be constructed of zinc coated, heavy gauge, galvanized steel. Exterior surfaces shall be cleaned, phosphatized, and finished with a weather-resistant baked enamel finish. Unit's surface shall be tested 672 hours in a salt spray test in compliance with ASTM B117. Cabinet construction shall allow for all maintenance on one side of the unit. In order to ensure a water and air tight seal, service panels shall have lifting handles and no more than three screws to remove. All exposed vertical panels and top covers in the indoor air section shall be insulated with a 1/2-inch, 1-pound density foil-faced, fire-resistant, permanent, odorless, glass fiber material. The base of the downflow unit shall be insulated with 1/2-inch, 1-pound density foil-faced, closed-cell material. The downflow unit's base pan shall have no penetrations within the perimeter of the curb other than the raised 1-1/8-inch high supply/return openings to provide an added water integrity precaution, if the condensate drain backs up. The base of the unit shall have provisions for forklift, from two long sides of the unit and crane lifting with option to add condenser third side forking.

Compressors

All units shall have direct-drive, hermetic, scroll type compressors with centrifugal type oil pumps. Motor shall be suction gas-cooled and shall have a voltage utilization range of plus or minus 10 percent of nameplate voltage. Internal overloads shall be provided with the scroll compressors. All models shall have phase monitors and low and high pressure control as standard.

Controls

Unit shall be completely factory wired with necessary controls and contactor pressure lugs or terminal block for power wiring. Unit shall provide an external location for mounting a fused disconnect device.

Crankcase Heaters (15 - 20 Tons)

These band heaters provide improved compressor reliability by warming the oil to prevent migration during off-cycles or low ambient conditions.

Discharge Line Thermostat

A bi-metal element discharge line thermostat is installed as a standard option on the discharge line of each system. This standard option provides extra protection to the compressors against high discharge temperatures in case of loss of charge, extremely high ambient and other conditions which could drive the discharge temperature higher. Discharge line thermostat is wired in series with high pressure control. When the discharge temperature rises above the protection limit, the bi-metal disc in the thermostat switches to the off position, opening the 24 Vac circuit. When the temperature on the discharge line cools down, the bi-metal disc closes the contactor circuit, providing power to the compressor.

Evaporator and Condenser Coils

Microchannel coils will be burst tested by the manufacturer. Microchannel evaporator and condenser coils shall be standard on all units. Coils shall be leak tested to ensure the pressure integrity. The evaporator coil and condenser coil shall be leak tested to 225 psig and pressure tested to 450 psig. Sloped condensate drain pans are standard.

Filters

Two inch standard filters shall be factory supplied on all units.

Gas Heating Section

The heating section shall have a tubular heat exchanger design. An induced draft combustion blower shall be used to pull the combustion products through the firing tubes. The heater shall use a direct spark ignition (DSI) system. On initial call for heat, the combustion blower shall purge the heat exchanger for 20 seconds before ignition. After three unsuccessful ignition attempts, the entire heating system shall be locked out until manually reset at the thermostat. Units shall be suitable for use with natural gas or propane (field-installed kit) and also comply with the California requirement for low NOx emissions (gas heat only).

Pressure Control

All units include High and Low Pressure Cutout as standard.

Indoor Fan

Units above shall have belt driven, FC centrifugal fans with adjustable motor sheaves. All motors shall be thermally protected. Oversized motors shall be available for high static application. All indoor fan motors meet the U.S. Energy Policy Act of 1992 (EPACT).

Low Pressure Control

All units include low pressure cutout as standard.

Locking Safety Device

Pressure switch monitoring allows for lockout in a situation where the switch is opened. By monitoring the Y input as well as the pressure switches, advanced decision making can be made to identify situations where faults/errors occur.

Outdoor Fans

The outdoor fan shall be direct-drive, statically and dynamically balanced, draw-through in the vertical discharge position. The fan motor(s) shall be permanently lubricated and shall have built-in thermal overload protection.

Phase Monitor

The Phase Monitor is a three-phase line monitor module that protects against phase loss, phase reversal and phase unbalance. It is intended to protect compressors from reverse rotation. It has an operating input voltage range of 180–632 Vac, and LED indicators for ON and FAULT. There are no field adjustments and the module will automatically reset from a fault condition.

Refrigerant Circuits

Each refrigerant circuit shall have thermostatic expansion valves, service pressure ports, and refrigerant line filter driers factory installed as standard. An area shall be provided for replacement suction line driers.

Unit Top

The top cover shall be double hemmed and gasket sealed to prevent water leakage.



Mechanical Specifications

Factory Installed Options

Complete Coat™ Microchannel Condenser Coil

The cathodic epoxy type electrodisposition coating is formulated for high edge build to a number of different types of heat exchangers. The coating is selected to provide excellent resistance and durability to corrosive effects of alkalis, acids, alcohols, petroleum, seawater, salty air, and other corrosive environments. This coating shall be available on microchannel condenser coils.

Multi-Speed Indoor Fan System

Multi-speed indoor fan system is designed for use in applications for meeting the minimum requirement of CA Title 24. This system incorporates a multi-speed fan control to change the speed of the fan to 67% of full airflow based off of compressor stages.

Stainless Steel Heat Exchanger

Gas heat exchanger shall be of tubular heat exchanger design constructed from a minimum 304 grade stainless steel tubes and 439 stainless steel burners. The stainless steel heat exchanger shall have a 10-year warranty as standard (Gas/Electric only).

Third Side Fork Access

This option shall provide fork openings on condenser end of unit for ease of maneuvering unit through narrow openings.

Factory or Field Installed Options

Barometric Relief

Designed to be used on downflow units, barometric relief is an unpowered means of relieving excess building pressure.

Condensate Overflow Switch

This option shall shut the unit down in the event that a clogged condensate drain line prevents proper condensate removal from the unit.

Economizer (Standard) – Downflow

The assembly includes fully modulating 0–100% motor and dampers, barometric relief, minimum position setting, preset linkage, wiring harness with plug, fixed dry bulb and spring return actuator. The barometric relief damper shall provide a pressure operated damper that shall be gravity closing and shall prohibit entrance of outside air during the equipment “off” cycle.

Electric Heaters

Electric heat modules shall be available for installation within the basic unit. Electric heater elements shall be constructed of heavy-duty nickel chromium elements internally delta connected for 240 volt, wye connected for 480 and 600 volt. Each heater package shall have temperature high limiting devices that are equipped with an auto-resetting and a single operation switch operating as line break limits. Single operation switch shall act as a backup limit control if the auto resetting switch fail to operate appropriately. All heaters shall be individually fused from the factory, where required, and shall meet all NEC and CEC requirements when properly installed. Power assemblies shall provide single-point connection. Electric heat modules shall be UL listed or CSA certified. If ordering the Through the Base Electrical option with an Electric Heater, the heater must be factory installed.

Low Leak Economizer with Fault Detection & Diagnostics - Downflow

This economizer meets the damper leakage requirements for ASHRAE 90.1, IECC, and California Title 24 standards (3 cfm/ft² at 1.0 in. w.g. for outside air dampers and 4 cfm/ft² for return dampers). The controller shall have the capability to provide the value of each sensor used in controlling the economizer operation. System status is also indicted for the following conditions:

- Free cooling available
- Economizer enabled
- Compressor enabled
- Heating Enabled
- Mixed air low limit cycle active

The Fault Detection and Diagnostic system detects the following faults:

- Air temperature sensor failure/fault
- Not economizing when conditions indicate system should be economizing
- Economizing when conditions indicate system should not be economizing
- Dampers are not modulating
- Excessive amounts of outside air are being introduced though the economizer

The Fault Detection and Diagnostic system is certified by the California Energy Commission as meeting requirements of California Title 24 120.2(i)1 through 120.2(i)8 in accordance with Section 100(h).

Manual Outside Air Damper

The rain hood and screen shall provide up to 25% outside air.

Motorized Outside Air Dampers

Manually set outdoor air dampers shall provide up to 50% outside air. Once set, outdoor air dampers shall open to set position when indoor fan starts. The damper shall close to the full closed position when indoor fan shuts down.

Oversized Motors

Oversized motors shall be available for high static applications.

Note: 10 hp oversized motor is factory installed only.

Reference or Comparative Enthalpy

Reference Enthalpy is used to measure and communicate outdoor humidity. The unit receives and uses this information to provide improved comfort cooling while using the economizer. Comparative Enthalpy measures and communicates humidity for both outdoor and return air conditions, and return air temperature. The unit receives and uses this information to maximize use of economizer cooling, and to provide maximum occupant comfort control. Reference or Comparative Enthalpy option shall be available when a factory or field installed Downflow Economizer is ordered. This option is available on all models.

Through the Base Electrical with Disconnect Switch

Three-pole, molded case, disconnect switch with provisions for through the base electrical connections are available. The disconnect switch will be installed in the unit in a water tight enclosure with access through a swinging door. Factory wiring will be provided from the switch to the unit high voltage terminal block. The switch will be UL/CSA agency recognized.

Note: The disconnect switch will be sized per NEC and UL guidelines but will not be used in place of unit overcurrent protection.

Through the Base Gas Piping

The unit shall include a standard through the base gas provision. This option shall have all piping necessary including, black steel, manual gas shut-off valve, elbows, and union. The manual shutoff valve shall include a 1/8" NPT pressure tap. This assembly will require minor field labor to install (Gas/Electric Only).



Mechanical Specifications

Through the Base Utilities Access

An electrical service entrance shall be provided allowing electrical access for both control and main power connections inside the curb and through the base of the unit. Option will allow for field installation of liquid-tight conduit and an external field installed disconnect switch.

Field Installed Options

Crankcase Heaters (25 Tons)

These band heaters provide improved compressor reliability by warming the oil to prevent migration during off-cycles or low ambient conditions.

Demand Control Ventilation with CO₂ Sensor

The CO₂ sensor shall have the ability to monitor the concentration (parts per million, ppm) of CO₂ (Carbon Dioxide) in the air. As the CO₂ concentration changes, the outside air damper modulates to meet the current ventilation needs of the zone.

Economizer—Horizontal

The horizontal economizer shall contain the same features as the downflow economizer with the exception of barometric relief.

Hail Guards

Hail protection coil guards are available for condenser coil protection.

Low and High Static Drive

The high static drive option shall allow the standard motor on all units to operate at various external static pressure conditions.

Low Leak Economizer with Fault Detection & Diagnostics - Horizontal

This economizer meets the damper leakage requirements for ASHRAE 90.1, IECC, and California Title 24 standards (3 cfm/ft² at 1.0 in. w.g. for outside air dampers and 4 cfm/ft² for return dampers). The controller shall have the capability to provide the value of each sensor used in controlling the economizer operation. System status is also indicated for the following conditions:

- Free cooling available
- Economizer enabled
- Compressor enabled
- Heating Enabled
- Mixed air low limit cycle active

The Fault Detection and Diagnostic system detects the following faults:

- Air temperature sensor failure/fault
- Not economizing when conditions indicate system should be economizing
- Economizing when conditions indicate system should not be economizing
- Dampers are not modulating
- Excessive amounts of outside air are being introduced through the economizer

The Fault Detection and Diagnostic system is certified by the California Energy Commission as meeting requirements of California Title 24 120.2(i)1 through 120.2(i)8 in accordance with Section 100(h).

Powered Exhaust

The powered exhaust shall provide exhaust of return air, when using an economizer, to maintain better building pressurization.

Remote Potentiometer

The minimum position setting of the economizer shall be adjusted with this accessory.

Roof Curb—Downflow

The roof curb shall be designed to mate with the downflow unit and provide support and a water tight installation when installed properly. The roof curb design shall allow field-fabricated rectangular supply/return ductwork to be connected directly to the curb. Curb shall be shipped knocked down for field assembly and shall include wood nailer strips.

Two-Inch Pleated Filters

Two-inch MERV 13 filters shall be available on all models.



Trane - by Trane Technologies (NYSE: TT), a global climate innovator - creates comfortable, energy efficient indoor environments for commercial and residential applications. For more information, please visit trane.com or tranetechnologies.com.

Trane has a policy of continuous product and product data improvement and reserves the right to change design and specifications without notice. We are committed to using environmentally conscious print practices.