

**ROG STRIX
X299-E
GAMING II**

ASUS[®]

Motherboard

E15991
Revised Edition V2
October 2019

Copyright© 2019 ASUSTeK COMPUTER INC. All Rights Reserved.

No part of this manual, including the products and software described in it, may be reproduced, transmitted, transcribed, stored in a retrieval system, or translated into any language in any form or by any means, except documentation kept by the purchaser for backup purposes, without the express written permission of ASUSTeK COMPUTER INC. ("ASUS").

Product warranty or service will not be extended if: (1) the product is repaired, modified or altered, unless such repair, modification of alteration is authorized in writing by ASUS; or (2) the serial number of the product is defaced or missing.

ASUS PROVIDES THIS MANUAL "AS IS" WITHOUT WARRANTY OF ANY KIND, EITHER EXPRESS OR IMPLIED, INCLUDING BUT NOT LIMITED TO THE IMPLIED WARRANTIES OR CONDITIONS OF MERCHANTABILITY OR FITNESS FOR A PARTICULAR PURPOSE. IN NO EVENT SHALL ASUS, ITS DIRECTORS, OFFICERS, EMPLOYEES OR AGENTS BE LIABLE FOR ANY INDIRECT, SPECIAL, INCIDENTAL, OR CONSEQUENTIAL DAMAGES (INCLUDING DAMAGES FOR LOSS OF PROFITS, LOSS OF BUSINESS, LOSS OF USE OR DATA, INTERRUPTION OF BUSINESS AND THE LIKE), EVEN IF ASUS HAS BEEN ADVISED OF THE POSSIBILITY OF SUCH DAMAGES ARISING FROM ANY DEFECT OR ERROR IN THIS MANUAL OR PRODUCT.

SPECIFICATIONS AND INFORMATION CONTAINED IN THIS MANUAL ARE FURNISHED FOR INFORMATIONAL USE ONLY, AND ARE SUBJECT TO CHANGE AT ANY TIME WITHOUT NOTICE, AND SHOULD NOT BE CONSTRUED AS A COMMITMENT BY ASUS. ASUS ASSUMES NO RESPONSIBILITY OR LIABILITY FOR ANY ERRORS OR INACCURACIES THAT MAY APPEAR IN THIS MANUAL, INCLUDING THE PRODUCTS AND SOFTWARE DESCRIBED IN IT.

Products and corporate names appearing in this manual may or may not be registered trademarks or copyrights of their respective companies, and are used only for identification or explanation and to the owners' benefit, without intent to infringe.

Offer to Provide Source Code of Certain Software

This product contains copyrighted software that is licensed under the General Public License ("GPL"), under the Lesser General Public License Version ("LGPL") and/or other Free Open Source Software Licenses. Such software in this product is distributed without any warranty to the extent permitted by the applicable law. Copies of these licenses are included in this product.

Where the applicable license entitles you to the source code of such software and/or other additional data, you may obtain it for a period of three years after our last shipment of the product, either

(1) for free by downloading it from <https://www.asus.com/support/>

or

(2) for the cost of reproduction and shipment, which is dependent on the preferred carrier and the location where you want to have it shipped to, by sending a request to:

ASUSTeK Computer Inc.
Legal Compliance Dept.
15 Li Te Rd.,
Beitou, Taipei 112
Taiwan

In your request please provide the name, model number and version, as stated in the About Box of the product for which you wish to obtain the corresponding source code and your contact details so that we can coordinate the terms and cost of shipment with you.

The source code will be distributed WITHOUT ANY WARRANTY and licensed under the same license as the corresponding binary/object code.

This offer is valid to anyone in receipt of this information.

ASUSTeK is eager to duly provide complete source code as required under various Free Open Source Software licenses. If however you encounter any problems in obtaining the full corresponding source code we would be much obliged if you give us a notification to the email address gpl@asus.com, stating the product and describing the problem (please DO NOT send large attachments such as source code archives, etc. to this email address).

Contents

Safety information.....	vi
About this guide.....	vii
ROG STRIX X299-E GAMING II specifications summary.....	ix
Package contents.....	xiv
Installation tools and components.....	xv

Chapter 1: Product Introduction

1.1	Before you proceed.....	1-1
1.2	Motherboard layout.....	1-2
1.3	Central Processing Unit (CPU).....	1-4
1.4	System memory.....	1-5
1.5	Expansion slots.....	1-7
1.6	Onboard buttons and switches.....	1-9
1.7	Onboard jumpers.....	1-10
1.8	Onboard LEDs.....	1-12
1.9	Internal connectors.....	1-14

Chapter 2: Basic Installation

2.1	Building your PC system.....	2-1
2.1.1	CPU and heatsink installation.....	2-1
2.1.2	Cooling system installation.....	2-4
2.1.3	Motherboard installation.....	2-6
2.1.4	DIMM installation.....	2-7
2.1.5	ATX Power connection.....	2-8
2.1.6	SATA device connection.....	2-9
2.1.7	Front I/O connector.....	2-10
2.1.8	Expansion Card installation.....	2-11
2.1.9	M.2 installation.....	2-13
2.1.10	Wi-Fi antenna installation.....	2-18
2.2	BIOS update utility.....	2-19
2.3	Motherboard rear and audio connections.....	2-21
2.3.1	Rear I/O connection.....	2-21
2.3.2	Audio I/O connections.....	2-23
2.4	Starting up for the first time.....	2-25
2.5	Turning off the computer.....	2-25

Chapter 3: BIOS Setup

3.1	Knowing BIOS	3-1
3.2	BIOS setup program	3-2
3.2.1	Advanced Mode	3-3
3.2.2	EZ Mode.....	3-7
3.2.3	QFan Control.....	3-8
3.2.4	AI OC Guide.....	3-10
3.2.5	EZ Tuning Wizard	3-11
3.3	My Favorites	3-14
3.4	Main menu	3-16
3.5	Ai Tweaker menu	3-16
3.6	Advanced menu	3-18
3.6.1	CPU Configuration	3-18
3.6.2	Platform Misc Configuration	3-18
3.6.3	System Agent (SA) Configuration	3-18
3.6.4	PCH Configuration	3-19
3.6.5	PCH Storage Configuration.....	3-19
3.6.6	CPU Storage Configuration.....	3-20
3.6.7	Onboard Devices Configuration.....	3-20
3.6.8	APM Configuration	3-21
3.6.9	USB Configuration	3-21
3.6.10	HDD/SSD SMART Information	3-21
3.6.11	NVMe Configuration.....	3-21
3.6.12	PCH-FW Configuration	3-21
3.6.13	Network Stack Configuration.....	3-21
3.6.14	Intel(R) Rapid Storage Technology.....	3-21
3.7	Monitor menu	3-22
3.8	Boot menu	3-22
3.9	Tool menu	3-24
3.9.1	ASUS EZ Flash 3 Utility	3-24
3.9.2	Secure Erase	3-25
3.9.3	ASUS User Profile.....	3-26
3.9.4	ASUS SPD Information.....	3-26
3.9.5	ASUS Armoury Crate.....	3-26
3.9.6	Graphics Card Information	3-26
3.10	Exit menu	3-27
3.11	Updating BIOS	3-28
3.11.1	EZ Update	3-28
3.11.2	ASUS EZ Flash 3.....	3-29
3.11.3	ASUS CrashFree BIOS 3.....	3-31

Chapter 4: RAID Support

4.1 RAID configurations 4-1
 4.1.1 RAID definitions 4-1

Appendix

Q-Code table A-1
Notices A-5
ASUS contact information..... A-12

Safety information

Electrical safety

- To prevent electrical shock hazard, disconnect the power cable from the electrical outlet before relocating the system.
- When adding or removing devices to or from the system, ensure that the power cables for the devices are unplugged before the signal cables are connected. If possible, disconnect all power cables from the existing system before you add a device.
- Before connecting or removing signal cables from the motherboard, ensure that all power cables are unplugged.
- Seek professional assistance before using an adapter or extension cord. These devices could interrupt the grounding circuit.
- Ensure that your power supply is set to the correct voltage in your area. If you are not sure about the voltage of the electrical outlet you are using, contact your local power company.
- If the power supply is broken, do not try to fix it by yourself. Contact a qualified service technician or your retailer.

Operation safety

- Before installing the motherboard and adding devices on it, carefully read all the manuals that came with the package.
- Before using the product, ensure all cables are correctly connected and the power cables are not damaged. If you detect any damage, contact your dealer immediately.
- To avoid short circuits, keep paper clips, screws, and staples away from connectors, slots, sockets and circuitry.
- Avoid dust, humidity, and temperature extremes. Do not place the product in any area where it may become wet.
- Place the product on a stable surface.
- If you encounter technical problems with the product, contact a qualified service technician or your retailer.

About this guide

This user guide contains the information you need when installing and configuring the motherboard.

How this guide is organized

This guide contains the following parts:

1. Chapter 1: Product Introduction

This chapter describes the features of the motherboard and the new technology it supports. It includes description of the switches, jumpers, and connectors on the motherboard.

2. Chapter 2: Basic Installation

This chapter lists the hardware setup procedures that you have to perform when installing system components.

3. Chapter 3: BIOS Setup

This chapter tells how to change system settings through the BIOS Setup menus. Detailed descriptions of the BIOS parameters are also provided.

4. Chapter 4: RAID Support

This chapter describes the RAID configurations.

Where to find more information

Refer to the following sources for additional information and for product and software updates.

1. ASUS website

The ASUS website (www.asus.com) provides updated information on ASUS hardware and software products.

2. Optional documentation

Your product package may include optional documentation, such as warranty flyers that may have been added by your dealer. These documents are not part of the standard package.

Conventions used in this guide

To ensure that you perform certain tasks properly, take note of the following symbols used throughout this manual.



DANGER/WARNING: Information to prevent injury to yourself when trying to complete a task.



CAUTION: Information to prevent damage to the components when trying to complete a task.



IMPORTANT: Instructions that you **MUST** follow to complete a task.



NOTE: Tips and additional information to help you complete a task.

Typography

Bold text

Indicates a menu or an item to select.

Italics

Used to emphasize a word or a phrase.

<Key>

Keys enclosed in the less-than and greater-than sign means that you must press the enclosed key.

Example: <Enter> means that you must press the Enter or Return key.

<Key1> + <Key2> + <Key3>

If you must press two or more keys simultaneously, the key names are linked with a plus sign (+).

ROG STRIX X299-E GAMING II specifications summary

CPU	<p>Optimized for Intel® Core™ X-Series 10000 Processor Family, Intel® Core™ X-Series Processors Family(6-core above) on LGA 2066 Socket*</p> <p>Supports Intel® Virtual RAID on CPU (VROC)</p> <p>Supports 14nm CPU</p> <p>Supports Intel® Turbo Boost Max Technology 3.0**</p> <p>* Refer to www.asus.com for Intel® CPU support list.</p> <p>** The support of these features depends on the CPU types.</p>
Chipset	Intel® X299 Chipset
Memory	<p>Intel® Core™ i9 10000 X-Series CPU</p> <p>8 x DIMM, Max. 256GB, DDR4 4266+(O.C.) / 4133(O.C.) / 4000(O.C.) / 3866(O.C.) / 3800(O.C.) / 3733(O.C.) / 3600(O.C.) / 3466(O.C.) / 3400(O.C.) / 3333(O.C.) / 3300(O.C.) / 3200(O.C.) / 3000(O.C.) / 2933 / 2800 / 2666 / 2400 / 2133 MHz, Non-ECC, Un-buffered Memory*</p> <p>Intel® Core™ i9 9000/7000 and i7 9000/7000 X-Series CPU</p> <p>8 x DIMM, Max. 256GB, DDR4 4266+(O.C.) / 4133(O.C.) / 4000(O.C.) / 3866(O.C.) / 3800(O.C.) / 3733(O.C.) / 3600(O.C.) / 3466(O.C.) / 3400(O.C.) / 3333(O.C.) / 3300(O.C.) / 3200(O.C.) / 3000(O.C.) / 2933(O.C.) / 2800(O.C.) / 2666 / 2400 / 2133 MHz, Non-ECC, Un-buffered Memory*</p> <p>Quad channel memory architecture</p> <p>Supports Intel® Extreme Memory Profile (XMP)</p> <p>* Hyper DIMM support is subject to the physical characteristics of individual CPUs. Please refer to Memory QVL (Qualified Vendors Lists) on www.asus.com for details.</p>
Expansion Slots	<p>48-Lane CPU (Intel® Core™ i9 10000 X-Series CPU)</p> <p>3 x PCIe 3.0 x16 slots (supports x16, x16/x16, x16/x16/x8 modes)</p> <p>44-Lane CPU (Intel® Core™ i9 9000/7000 and i7 9000 X-Series CPU)</p> <p>3 x PCIe 3.0 x16 slots (supports x16, x16/x16, x16/x16/x4 modes)</p> <p>28-Lane CPU (Intel® Core™ i7 7000 X-Series CPU)</p> <p>3 x PCIe 3.0 x16 slots (supports x16, x16/x8, x16/x8/x4 modes)</p> <p>Intel® X299 Chipset</p> <p>1 x PCIe 3.0 x4 slot</p> <p>1 x PCIe 3.0 x1 slot*</p> <p>* PCIEX1 slot shares bandwidth with USB 3.2 Gen 2 front panel connector.</p>
Multi-GPU Support	<p>Supports NVIDIA® 3-Way/2-Way SLI® Technology</p> <p>Supports AMD 3-Way/2-Way CrossFireX™ Technology</p>

(continued on the next page)

ROG STRIX X299-E GAMING II specifications summary

<p>Storage</p>	<p>Intel® Core™ X-Series Processors support with Intel® Virtual RAID on CPU (VROC)</p> <ul style="list-style-type: none"> - 2 x M.2 Socket 3 with M key, type 2242/2260/2280/22110 storage devices support (PCIe 3.0 x4 mode)* <p>Intel® X299 Chipset supports with Intel® Rapid Storage Technology (RAID 0, 1, 5, 10)</p> <ul style="list-style-type: none"> - 8 x SATA 6Gb/s ports - 1 x M.2_1 Socket 3 with M key, type 2242/2260/2280/22110 storage devices support (both SATA & PCIe 3.0 x4 modes) - Intel® Optane Memory ready <p>* M.2_2 and M.2_3 are supported by 48-Lane CPU and 44-Lane CPU (Intel® Core™ i7 9000 X-Series CPU or above).</p>
<p>LAN</p>	<p>Intel® I219-V Gigabit LAN Realtek® RTL8125-CG 2.5G LAN Anti-surge LANGuard ROG GameFirst Technology</p>
<p>Wireless & Bluetooth</p>	<p>Intel® Wi-Fi 6 AX200</p> <p>2x2 Wi-Fi 6 (802.11 a/b/g/n/ac/ax) with MU-MIMO supports dual frequency band 2.4/5GHz</p> <p>Supports channel bandwidth: HT20/HT40/HT80/HT160</p> <p>Up to 2.4 Gbps transfer speed</p> <p>Bluetooth v5.0</p>
<p>Audio</p>	<p>ROG SupremeFX S1220A 8-Channel High Definition Audio CODEC</p> <ul style="list-style-type: none"> - Supports up to 32-Bit/192kHz playback* - Impedance sense for front and rear headphone outputs - High quality 120dB SNR stereo playback output and 113dB SNR recording input - SupremeFX Shielding Technology - Dual Headphone Amplifiers - Jack-detection, Multi-streaming, and Front Panel Jack-retasking - Optical S/PDIF out port at back panel <p>Audio Features:</p> <ul style="list-style-type: none"> - Gold-plated jacks - Sonic Studio III + Sonic Studio Virtual Mixer - Sonic Radar III - DTS® Sound Unbound <p>* Due to limitations in HDA bandwidth, 32-Bit/192kHz is not supported for 8-Channel audio.</p>

(continued on the next page)

ROG STRIX X299-E GAMING II specifications summary

<p>USB</p>	<p>Intel® X299 Chipset-</p> <ul style="list-style-type: none"> - 6 x USB 3.2 Gen 1 ports (2 ports at back panel [blue], 4 ports at mid-board) - 8 x USB 2.0 ports (4 ports at back panel, 4 ports at mid-board) <p>ASMedia® USB 3.2 Gen 2 controllers-</p> <ul style="list-style-type: none"> - 4 x USB 3.2 Gen 2 ports (3 x Type-A [red] and 1 x Type-C™ port at back panel) - 1 x USB 3.2 Gen 2 front panel connector* <p>* The USB 3.2 Gen 2 front panel connector shares bandwidth with PCIe x1 slot.</p>
<p>ROG Exclusive Features</p>	<p>ROG RAMCache III ROG GameFirst V ROG CPU-Z ROG Overwolf Sonic Studio III + Sonic Studio Virtual Mixer Sonic Radar III FlexKey</p>
<p>Special Features</p>	<p>Performance Optimization*</p> <p>5-Way Optimization</p> <ul style="list-style-type: none"> - Whole system optimization with a single click! Perfectly consolidates better CPU performance, power saving, digital power control, system cooling and app usages. <p>Digi+VRM</p> <p>EPU</p> <ul style="list-style-type: none"> - EPU <p>TPU</p> <ul style="list-style-type: none"> - Auto Tuning <p>Fan Xpert 4 featuring Fan Auto Tuning function and multiple thermistors selection for optimized system cooling control</p> <p>Turbo Core App (6-core or above CPU)</p> <p>* Only available on Intel® Core™ X-Series Processors</p> <p>LiveDash OLED</p> <p>AI Overclocking</p> <p>AURA:</p> <ul style="list-style-type: none"> - Aura Lighting Control - Aura RGB Strip Headers - Aura Addressable Gen 2 Headers <p>ASUS EZ DIY</p> <ul style="list-style-type: none"> - ASUS CrashFree BIOS 3 - ASUS EZ Flash 3 - EZ Tuning Wizard

(continued on the next page)

ROG STRIX X299-E GAMING II specifications summary

<p>Special Features</p>	<p>ASUS Q-Design</p> <ul style="list-style-type: none"> - Q-Code - Q-LED (CPU [red], DRAM [yellow], VGA [white], Boot Device [green]) - Q-Slot - Q-DIMM - Q-Connector <p>Gamer's Guardian</p> <ul style="list-style-type: none"> - Procool II - SafeSlot - DIGI+ VRM - DRAM Overcurrent Protection - ESD Guards on VGA, LAN, Audio and USB3.2/2.0 ports - Highly Durable Components - OC Design - ASUS PRO Clock II Technology ASUS Exclusive Features - Armoury Crate - Pre-mounted I/O Shield - ASUS NODE: hardware control interface - BIOS FlashBack™ - AURA Lighting Control - AI Suite 3 - AI Charger
<p>Back I/O Ports</p>	<ul style="list-style-type: none"> 1 x BIOS FlashBack™ Button 4 x USB 2.0 ports 2 x USB 3.2 Gen 1 ports [blue] 4 x USB 3.2 Gen 2 ports (3 x Type-A [red] and 1 x Type-C™ ports at back panel) 1 x Anti-surge LAN (RJ45) port 1 x Anti-surge 2.5G LAN (RJ45) port 1 x ASUS Wi-Fi Module 5 x Gold-plated Audio jacks 1 x Optical S/PDIF out

(continued on the next page)

ROG STRIX X299-E GAMING II specifications summary

Internal I/O Ports	<p>1 x Node connector</p> <p>1 x USB 3.2 Gen 2 front panel connector</p> <p>2 x USB 3.2 Gen 1 connectors support additional 4 x USB 3.2 Gen 1 ports</p> <p>2 x USB 2.0 connectors support additional 4 x USB 2.0 ports</p> <p>8 x SATA 6Gb/s connectors</p> <p>1 x 4-Pin W_PUMP+ connector</p> <p>1 x 4-Pin AIO_PUMP fan connector</p> <p>1 x 4-Pin CPU fan connector</p> <p>1 x 4-Pin CPU_OPT fan connector</p> <p>2 x 4-Pin Chassis fan connectors</p> <p>1 x 4-Pin M.2 fan connector</p> <p>1 x 24-pin EATX power connector</p> <p>2 x 8-pin EATX 12V power connectors</p> <p>1 x M.2_1 Socket 3 for M Key, type 2242/2260/2280/22110 storage devices support (Supports PCIe and SATA modes)</p> <p>2 x M.2_2 Socket 3 for M Key, type 2242/2260/2280/22110 storage devices support (Supports PCIe mode only)</p> <p>1 x Power-on button</p> <p>1 x Front panel audio connector (AAFP)</p> <p>1 x VROC_HW_KEY</p> <p>2 x RGB Headers</p> <p>2 x Addressable Gen 2 headers</p> <p>1 x System panel connector</p> <p>1 x Thermal sensor connector</p> <p>1 x CPU_OV</p> <p>1 x Clear CMOS jumper (2-pin)</p>
BIOS Features	128 Mb Flash ROM, UEFI AMI BIOS, PnP, WfM2.0, SM BIOS 3.2, ACPI 6.2
Manageability	WOL, PXE
Software	Overwolf Anti-virus software (OEM version) WinRAR
Operating System	Windows® 10 64-bit
Form Factors	ATX Form Factor, 12"x 9.6" (30.5cm x 24.4cm)



- Specifications are subject to change without notice.
- Visit the ASUS website for the software manual.

Package contents

Check your motherboard package for the following items:

Motherboard	1 x ROG STRIX X299-E GAMING II motherboard
Cables	4 x SATA 6Gb/s cables
	1 x Addressable LED extension cable
	1 x RGB LED extension cable
	1 x Thermal sensor cable
Accessories	1 x Wi-Fi Antenna(s)
	1 x Q-Connector kit
	1 x Vertical M.2 bracket set
	1 x M.2 screw package
	1 x Pack of cable ties
	1 x ROG Thank you card
	1 x ROG STRIX door hanger
1 x ROG STRIX sticker	
Application DVD	1 x ROG motherboard support DVD
Documentation	1 x User guide



If any of the above items is damaged or missing, contact your retailer.

Installation tools and components

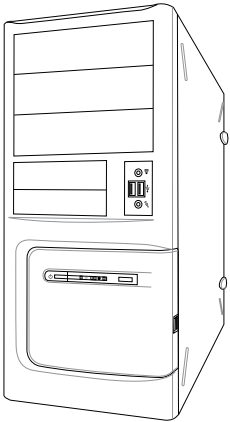

PC chassis

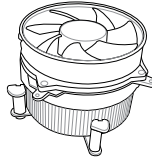

Intel® LGA2066 compatible CPU Fan

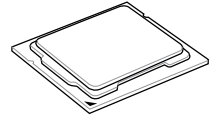

Intel® LGA2066 CPU

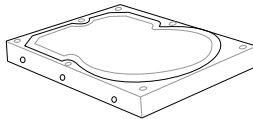

SATA hard disk drive



Phillips (cross) screwdriver

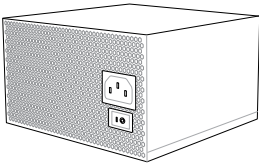

Power supply unit

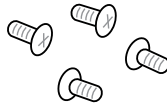

1 bag of screws

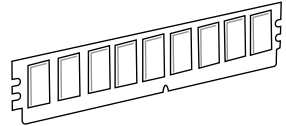

DIMM

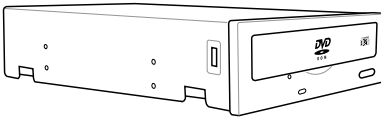

SATA optical disc drive (optional)

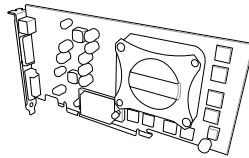

Graphics card



The tools and components in the table above are not included in the motherboard package.

Product Introduction

1.1 Before you proceed

Take note of the following precautions before you install motherboard components or change any motherboard settings.



-
- Unplug the power cord from the wall socket before touching any component.
 - Before handling components, use a grounded wrist strap or touch a safely grounded object or a metal object, such as the power supply case, to avoid damaging them due to static electricity.
 - Hold components by the edges to avoid touching the ICs on them.
 - Whenever you uninstall any component, place it on a grounded antistatic pad or in the bag that came with the component.
 - Before you install or remove any component, ensure that the ATX power supply is switched off or the power cord is detached from the power supply. Failure to do so may cause severe damage to the motherboard, peripherals, or components.
-

1.2 Motherboard layout

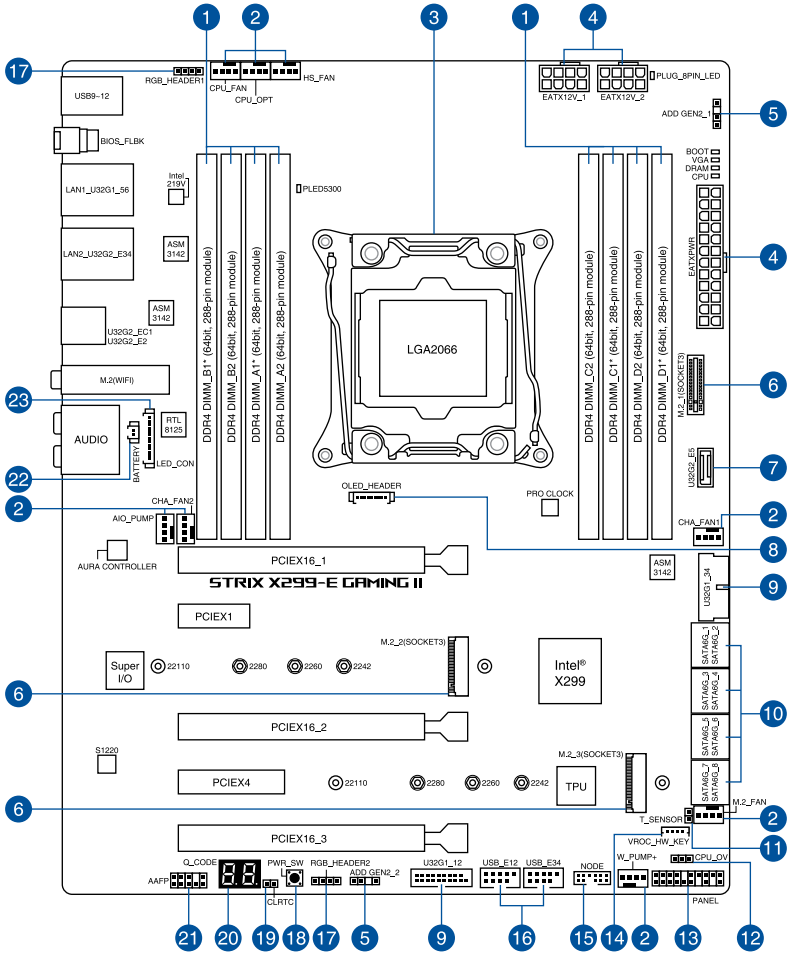

Refer to **Internal connectors** and **Rear I/O connection** for more information about rear panel connectors and internal connectors.

Layout contents	Page
1. DIMM slots	1-5
2. Fan and Pump connectors	1-18
3. CPU socket	1-4
4. Power connectors	1-19
5. Addressable Gen2 LED connector	1-22
6. M.2 slot	1-15
7. USB 3.2 Gen 2 connector	1-16
8. OLED connector	1-23
9. USB 3.2 Gen 1 connector	1-16
10. SATA 6Gb/s connector	1-14
11. Thermal Sensor connector	1-17
12. CPU Over Voltage jumper	1-11
13. System Panel connector	1-20
14. VROC Key connector	1-24
15. Node connector	1-24
16. USB 2.0 connector	1-17
17. AURA RGB LED connector	1-21
18. Power button	1-9
19. Clear RTC RAM jumper	1-10
20. Q-Code LED	1-12
21. Front Panel Audio connector	1-25
22. Battery connector	1-15
23. Rear I/O Cover LED connector	1-23

1.3 Central Processing Unit (CPU)

The motherboard comes with a surface mount LGA2066 socket designed for the Intel® Core™ X-series Processors.

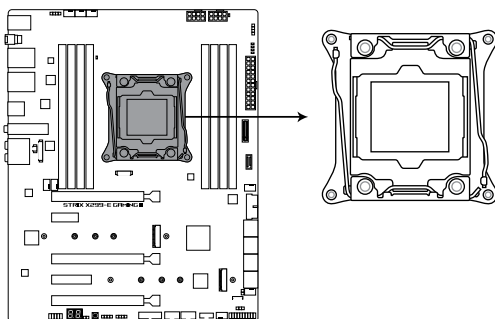

ROG STRIX X299-E GAMING II CPU LGA2066 Socket



- Ensure that you install the correct CPU designed for LGA2066 socket only. **DO NOT** install a CPU designed for other sockets on the LGA2066 socket.
- The CPU fits in only one correct orientation. **DO NOT** force the CPU into the socket to prevent bending the connectors on the socket and damaging the CPU.
- Ensure that all power cables are unplugged before installing the CPU.
- Upon purchase of the motherboard, ensure that the PnP cap is on the socket and the socket contacts are not bent. Contact your retailer immediately if the PnP cap is missing, or if you see any damage to the PnP cap/socket contacts/motherboard components. ASUS will shoulder the cost of repair only if the damage is shipment/transit-related.
- Keep the cap after installing the motherboard. ASUS will process Return Merchandise Authorization (RMA) requests only if the motherboard comes with the cap on the LGA2066 socket.
- The product warranty does not cover damage to the socket contacts resulting from incorrect CPU installation/removal, or misplacement/loss/incorrect removal of the PnP cap.

1.4 System memory

The motherboard comes with Dual Inline Memory Modules (DIMM) slots designed for DDR4 (Double Data Rate 4) memory modules.



A DDR4 memory module is notched differently from a DDR, DDR2, or DDR3 module. DO NOT install a DDR, DDR2, or DDR3 memory module to the DDR4 slot.

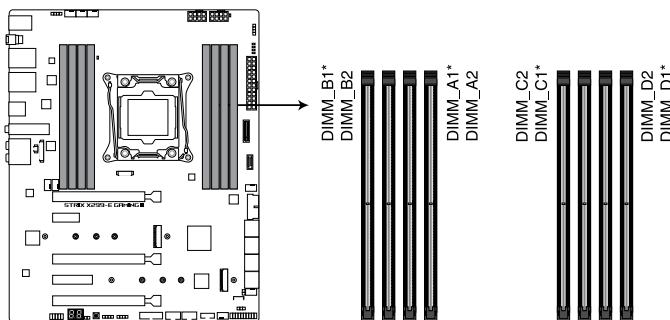

ROG STRIX X299-E GAMING II 288-pin DDR4 DIMM socket

Recommended memory configurations

Intel® Core™ X-series Processors (6-core or above)

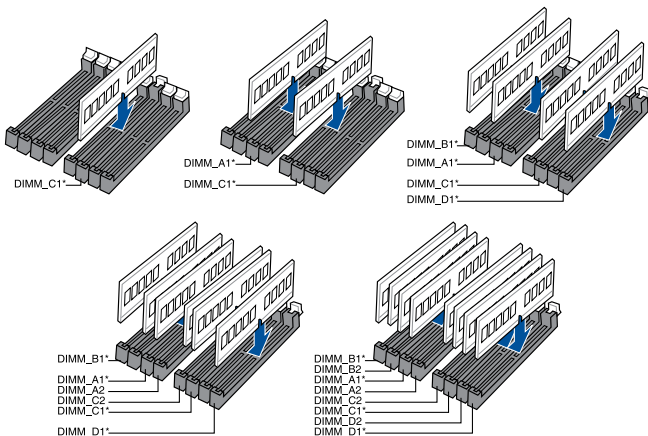

Memory configurations

You may install 4 GB, 8 GB, 16 GB, and 32 GB unbuffered and non-ECC DDR4 DIMMs into the DIMM sockets.



For Intel® Core™ X-Series Processors (6-core or above), you may install varying memory sizes in Channel A, Channel B, Channel C, and Channel D. The system maps the total size of the lower-sized channel for the quad-channel configuration. Any excess memory from the higher-sized channel is then mapped for single-channel operation.



- The default memory operation frequency is dependent on its Serial Presence Detect (SPD), which is the standard way of accessing information from a memory module. Under the default state, some memory modules for overclocking may operate at a lower frequency than the vendor-marked value.
 - For system stability, use a more efficient memory cooling system to support a full memory load or overclocking condition.
 - Always install the DIMMS with the same CAS Latency. For an optimum compatibility, we recommend that you install memory modules of the same version or data code (D/C) from the same vendor. Check with the vendor to get the correct memory modules.
 - Visit the ASUS website for the latest QVL.
-

1.5 Expansion slots



Unplug the power cord before adding or removing expansion cards. Failure to do so may cause you physical injury and damage motherboard components.

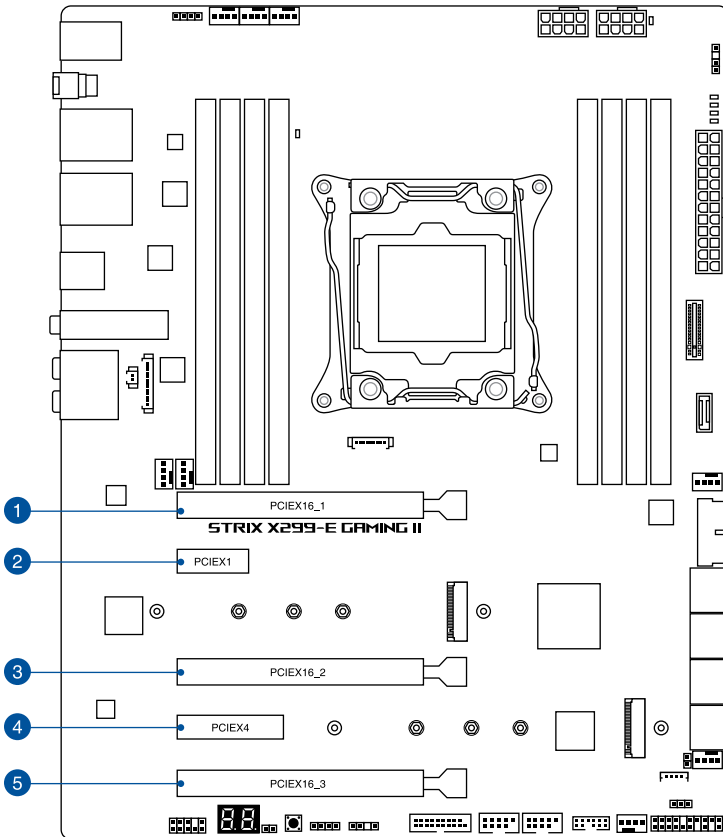

Recommended VGA configuration

48-LANE CPU

Slot Description	Single VGA	Dual VGA	Triple VGA
1. PCIe 3.0 x16_1	x16	x16	x16
2. PCIe 3.0 x1	x1	x1	x1
3. PCIe 3.0 x16_2	-	x16	x16
4. PCIe 3.0 x4	x4	x4	x4
5. PCIe 3.0 x16_3	-	-	x8

44-LANE CPU

Slot Description	Single VGA	Dual VGA	Triple VGA
1. PCIe 3.0 x16_1	x16	x16	x16
2. PCIe 3.0 x1	x1	x1	x1
3. PCIe 3.0 x16_2	-	x16	x16
4. PCIe 3.0 x4	x4	x4	x4
5. PCIe 3.0 x16_3	-	-	x4

28-LANE CPU

Slot Description	Single VGA	Dual VGA	Triple VGA
1. PCIe 3.0 x16_1	x16	x16	x16
2. PCIe 3.0 x1	x1	x1	x1
3. PCIe 3.0 x16_2	-	x8	x8
4. PCIe 3.0 x4	x4	x4	x4
5. PCIe 3.0 x16_3	-	-	x4



- We recommend that you provide sufficient power when running CrossFireX™ or SLI® mode.
- Ensure to connect both the 8-pin power plugs when running CrossFireX™ or SLI® mode.
- Connect a chassis fan to the chassis fan connectors when using multiple graphics cards for better thermal environment.

1.6 Onboard buttons and switches

1. Power button

Press the Power button to power up the system, or put the system into sleep or soft-off mode (depending on the operating system settings).

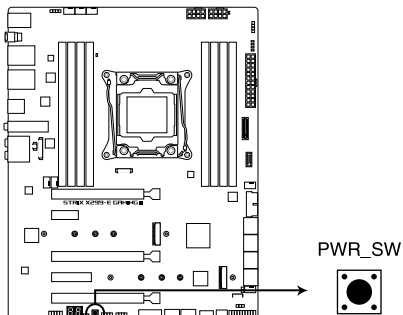

ROG STRIX X299-E GAMING II Power on button



The LED near the button also lights up when the system is plugged to a power source indicating that you should shut down the system and unplug the power cable before removing or installing any motherboard component.

1.7 Onboard jumpers

1. Clear RTC RAM jumper

The Clear RTC RAM jumper allows you to clear the Real Time Clock (RTC) RAM in the CMOS, which contains the date, time, system passwords, and system setup parameters.

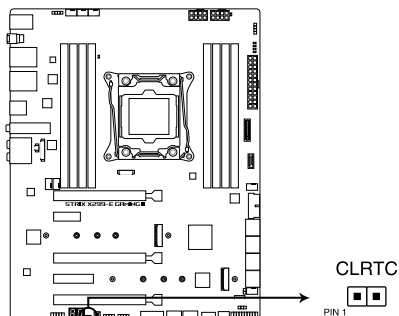

ROG STRIX X299-E GAMING II Clear RTC RAM jumper

To erase the RTC RAM:

1. Turn OFF the computer and unplug the power cord.
2. Short-circuit pin 1-2 with a metal object or jumper cap for about 5-10 seconds.
3. Plug the power cord and turn ON the computer.
4. Hold down the key during the boot process and enter BIOS setup to re-enter data.



DO NOT short-circuit the pins except when clearing the RTC RAM. Short-circuiting or placing a jumper cap will cause system boot failure!



If the steps above do not help, remove the onboard button cell battery and move the jumper again to clear the CMOS RTC RAM data. After clearing the CMOS, reinstall the button cell battery.

2. CPU Over Voltage jumper

The CPU Over Voltage jumper allows you to set a higher CPU voltage for a flexible overclocking system (depending on the type of the installed CPU). Set to pins 2-3 to increase the CPU voltage setting, or set to pins 1-2 to use the default CPU voltage setting.

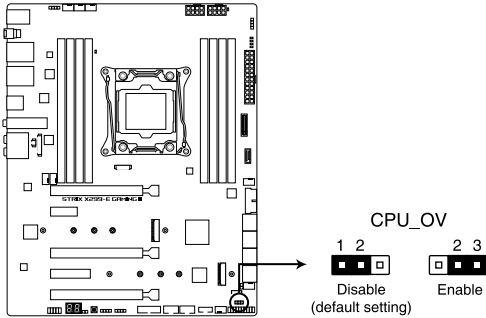

ROG STRIX X299-E GAMING II CPU Over Voltage jumper

1.8 Onboard LEDs

1. POST State LEDs

The POST State LEDs check key components (CPU, DRAM, VGA, and booting devices) during the motherboard booting process. If an error is found, the critical component's LED stays lit up until the problem is solved.

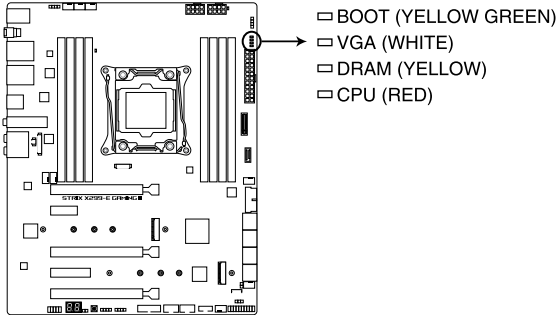

ROG STRIX X299-E GAMING II Q LEDs



The POST State LEDs provide the most probable cause of an error code as a starting point for troubleshooting. The actual cause may vary from case to case.

2. Q-Code LED

The Q-Code LED design provides you with a 2-digit error code that displays the system status.

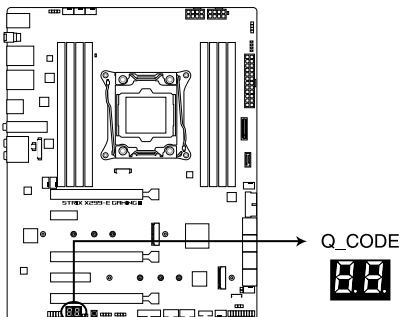

ROG STRIX X299-E GAMING II Q-Code LED



- The Q-Code LEDs provide the most probable cause of an error code as a starting point for troubleshooting. The actual cause may vary from case to case.
- Please refer to the Q-Code table in the **Appendix** section for more details.

3. 8-pin Power Plug LED

The 8-pin Power Plug LED lights up to indicate that the 8-pin power plug is not connected.

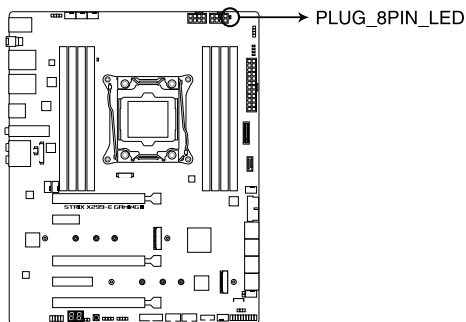

ROG STRIX X299-E GAMING II 8-pin Power Plug LED

1.9 Internal connectors

1. SATA 6Gb/s connector

The SATA 6Gb/s connector allows you to connect SATA devices such as optical disc drives and hard disk drives via a SATA cable.

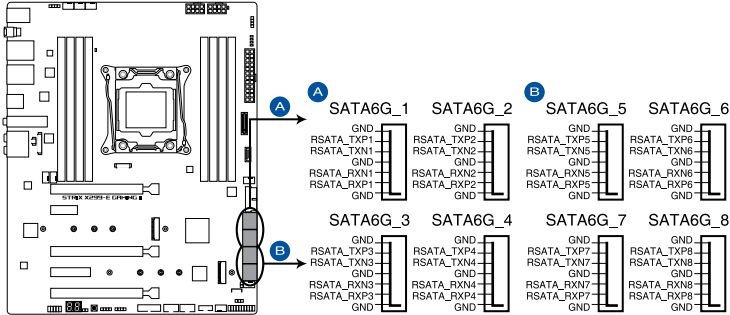

ROG STRIX X299-E GAMING II SATA 6 Gb/s connector

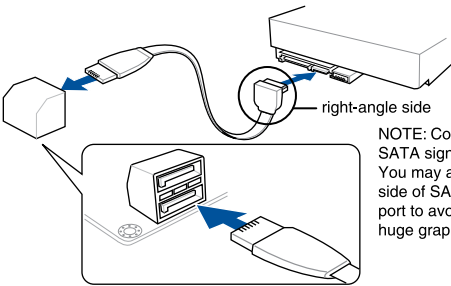

NOTE: Connect the right-angle side of SATA signal cable to SATA device. You may also connect the right-angle side of SATA cable to the onboard SATA port to avoid mechanical conflict with huge graphics cards.



If you installed SATA storage devices, you can create a RAID 0, 1, 5, and 10 configuration with the Intel® Rapid Storage Technology through the onboard Intel® X299 chipset.



- The connectors are set to **[Intel RST Premium (RAID)]** by default.
- Before creating a RAID set, refer to the **RAID Configuration Guide**. You can download the **RAID Configuration Guide** from the ASUS website.

2. M.2 slot

The M.2 slot allows you to install M.2 devices such as M.2 SSD modules.

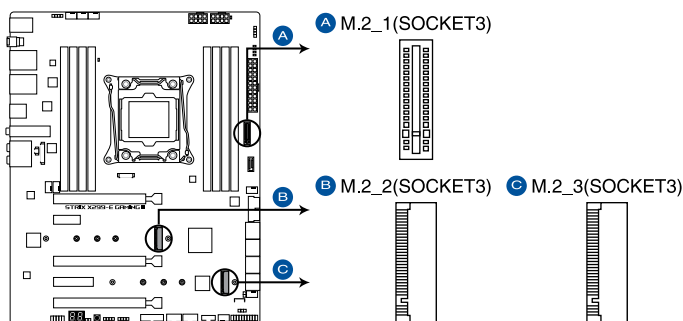

ROG STRIX X299-E GAMING II M.2 slot



- M.2_1 socket supports PCIe 3.0 x4 and SATA modes M Key design and type 2242 / 2260 / 2280 / 22110 storage devices.
- M.2_2 and M.2_3 sockets support PCIe 3.0 x4 mode M Key design and type 2242 / 2260 / 2280 / 22110 storage devices.
- M.2_1 socket supports IRST (Intel® Rapid Storage Technology).
- M.2_2 and M.2_3 sockets supports Intel® VROC (Intel® Virtual RAID on CPU).



- The M.2 SSD module is purchased separately.
- This motherboard supports PCIe SSD devices only.

3. Battery connector

The Battery connector allows you to install a battery to power the real-time clock and store your BIOS settings.

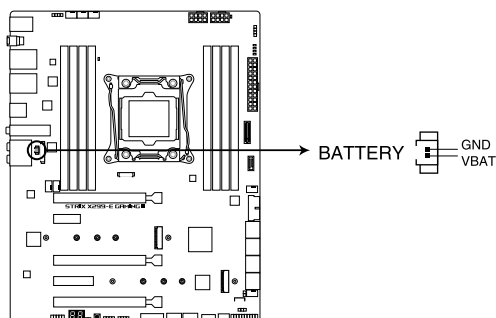

ROG STRIX X299-E GAMING II Battery connector

4. USB 3.2 Gen 2 connector

The USB 3.2 Gen 2 connector allows you to connect a USB 3.2 Gen 2 module for additional USB 3.2 Gen 2 ports. The USB 3.2 Gen 2 connector provides data transfer speeds of up to 10 Gb/s.

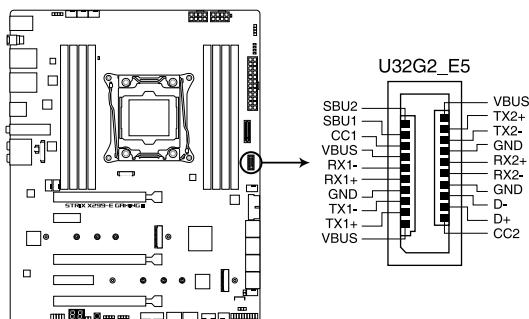

ROG STRIX X299-E GAMING II USB 3.2 Gen 2 connector



The USB 3.2 Gen 2 module is purchased separately.

5. USB 3.2 Gen 1 connector

The USB 3.2 Gen 1 connector allows you to connect a USB 3.2 Gen 1 module for additional USB 3.2 Gen 1 ports. The USB 3.2 Gen 1 connector provides data transfer speeds of up to 5 Gb/s.

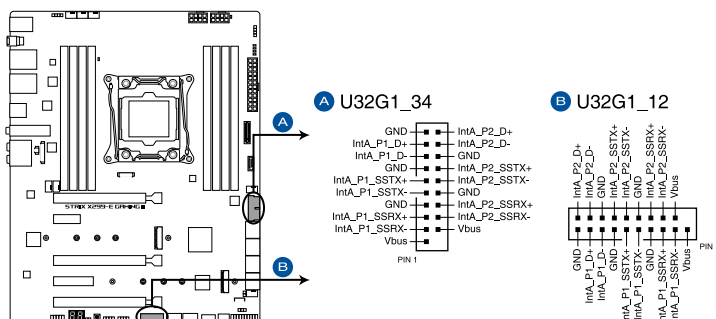

ROG STRIX X299-E GAMING II USB 3.2 Gen 1 connector



The USB 3.2 Gen 1 module is purchased separately.

6. USB 2.0 connector

The USB 2.0 connector allows you to connect a USB module for additional USB 2.0 ports. The USB 2.0 connector provides data transfer speeds of up to 480 MB/s connection speed.

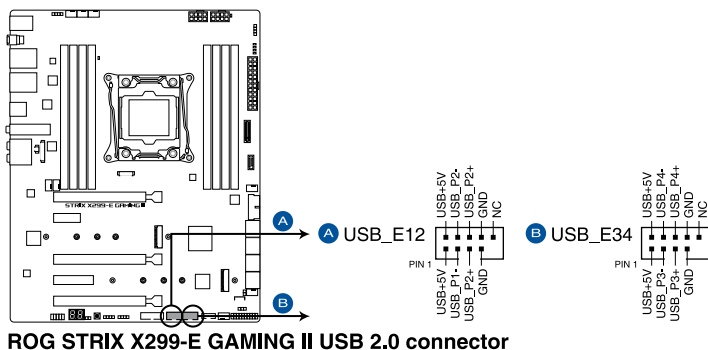

DO NOT connect a 1394 cable to the USB connectors. Doing so will damage the motherboard!



The USB 2.0 module is purchased separately.

7. Thermal Sensor connector

The Thermal Sensor connector allows you to connect a sensor to monitor the temperature of the devices and the critical components inside the motherboard. Connect the thermal sensor and place it on the device or the motherboard's component to detect its temperature.

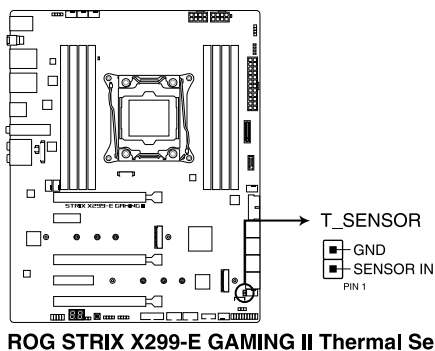

The thermal sensor is purchased separately.

8. Fan and Pump connectors

The Fan and Pump connectors allow you to connect fans or pumps to cool the system.

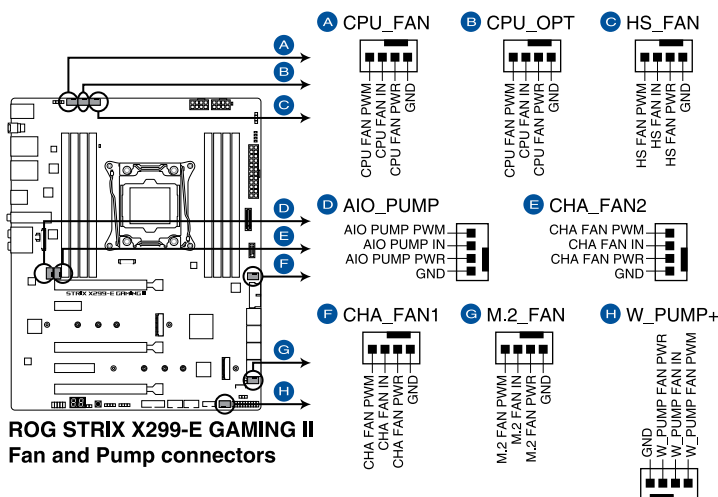

- DO NOT forget to connect the fan cables to the fan connectors. Insufficient air flow inside the system may damage the motherboard components. These are not jumpers! Do not place jumper caps on the fan connectors!
- Ensure the cable is fully inserted into the connector.



- For water cooling kits, connect the pump connector to the **W_PUMP+** connector, then connect the fan connectors to the **CPU_FAN** and **CPU_OPT** connectors.
- For All-In-One coolers, connect the pump connector to the **AIO_PUMP** connector, then connect the fan connectors to the **CPU_FAN** and **CPU_OPT** connectors.

Header	Max. Current	Max. Power	Default Speed	Shared Control
CPU_FAN	1A	12W	Q-Fan Controlled	A
CPU_OPT	1A	12W	Q-Fan Controlled	A
CHA_FAN1	1A	12W	Q-Fan Controlled	-
CHA_FAN2	1A	12W	Q-Fan Controlled	-
HS_FAN	1A	12W	Q-Fan Controlled	-
M.2_FAN	1A	12W	Q-Fan Controlled	-
AIO_PUMP	1A	12W	Full-Speed	-
W_PUMP+	3A	36W	Full-Speed	-

9. Power connectors

These Power connectors allow you to connect your motherboard to a power supply. The power supply plugs are designed to fit in only one orientation, find the proper orientation and push down firmly until the power supply plugs are fully inserted.

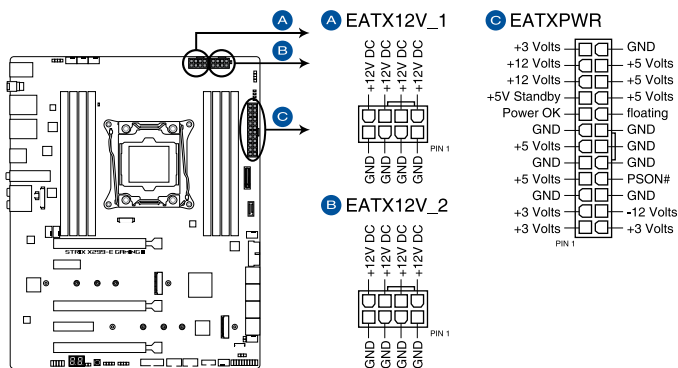

ROG STRIX X299-E GAMING II Power connectors



Ensure to connect the 8-pin power plug.



- For a fully configured system, we recommend that you use a power supply unit (PSU) that complies with ATX 12V Specification 2.0 (or later version) and provides a minimum power of 350 W.
- We recommend that you use a PSU with a higher power output when configuring a system with more power-consuming devices. The system may become unstable or may not boot up if the power is inadequate.
- If you want to use two or more high-end PCI Express x16 cards, use a PSU with 1000W power or above to ensure the system stability.

10. System Panel connector

The System Panel connector supports several chassis-mounted functions.

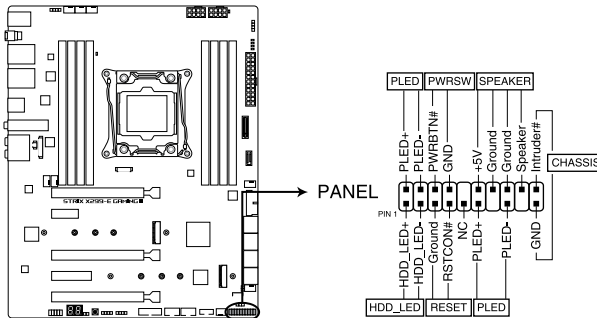

ROG STRIX X299-E GAMING II System panel connector

- **System Power LED connector (PLED)**

The 2-pin and/or 3-1 pin connectors allow you to connect the System Power LED. The System Power LED lights up when the system is connected to a power source, or when you turn on the system power, and blinks when the system is in sleep mode.

- **Storage Device Activity LED connector (HDD_LED)**

The 2-pin connector allows you to connect the Storage Device Activity LED. The Storage Device Activity LED lights up or blinks when data is read from or written to the storage device or storage device add-on card.

- **System Warning Speaker connector (SPEAKER)**

The 4-pin connector allows you to connect the chassis-mounted system warning speaker. The speaker allows you to hear system beeps and warnings.

- **Power Button/Soft-off Button connector (PWRSW)**

The 3-1 pin connector allows you to connect the system power button. Press the power button to power up the system, or put the system into sleep or soft-off mode (depending on the operating system settings).

- **Reset button connector (RESET)**

The 2-pin connector allows you to connect the chassis-mounted reset button. Press the reset button to reboot the system.

- **Chassis intrusion connector (CHASSIS)**

The 2-pin connector allows you to connect the chassis-mounted intrusion detection sensor or switch. The chassis intrusion sensor or switch sends a high-level signal to the connector when a chassis component is removed or replaced, the signal is then generated as a chassis intrusion event.

11. AURA RGB LED connector

The AURA RGB LED connector allows you to connect RGB LED strips.

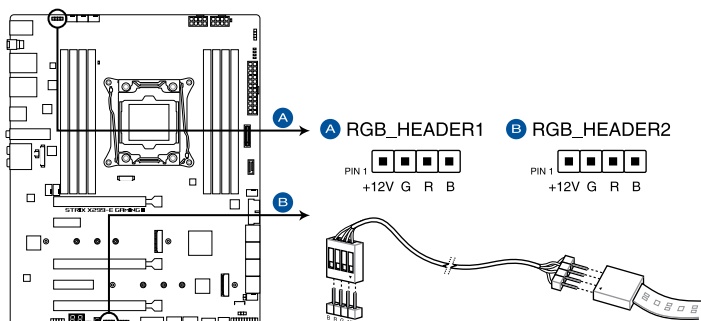

ROG STRIX X299-E GAMING II AURA RGB LED connector



The AURA RGB LED connector supports 5050 RGB multi-color LED strips (12V/G/R/B), with a maximum power rating of 3A (12V), and no longer than 3m.



Before you install or remove any component, ensure that the power supply is switched off or the power cord is detached from the power supply. Failure to do so may cause severe damage to the motherboard, peripherals, or components.



- Actual lighting and color will vary with LED strip.
- If your LED strip does not light up, check if the RGB LED extension cable and the RGB LED strip is connected in the correct orientation, and the 12V connector is aligned with the 12V header on the motherboard.
- The LED strip will only light up when the system is powered on.
- The LED strip is purchased separately.

12. Addressable Gen2 LED connector

The Addressable Gen2 LED connector allows you to connect individually addressable RGB WS2812B LED strips or WS2812B based LED strips.

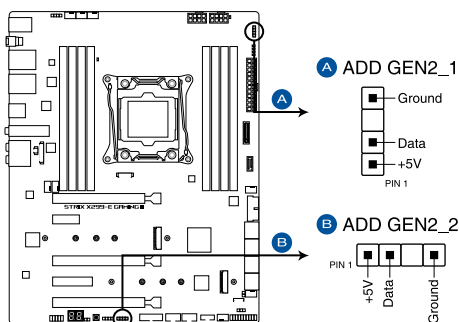

ROG STRIX X299-E GAMING II Addressable RGB LED connector



The Addressable Gen2 LED connector supports WS2812B addressable RGB LED strips (5V/Data/Ground), with a maximum power rating of 3A (5V) and a maximum of 120 LEDs.



Before you install or remove any component, ensure that the power supply is switched off or the power cord is detached from the power supply. Failure to do so may cause severe damage to the motherboard, peripherals, or components.



- Actual lighting and color will vary with LED strip.
- If your LED strip does not light up, check if the addressable RGB LED strip is connected in the correct orientation, and the 5V connector is aligned with the 5V header on the motherboard.
- The addressable RGB LED strip will only light up when the system is powered on.
- The addressable RGB LED strip is purchased separately.

13. Rear I/O Cover LED connector

The Rear I/O Cover LED connector is for connecting the LED strips on your rear I/O cover.

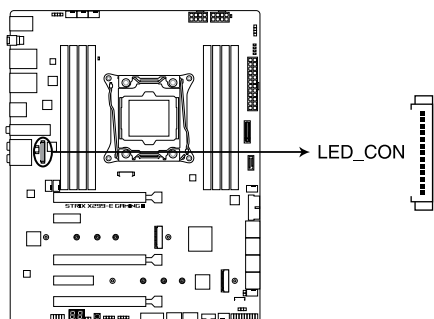

ROG STRIX X299-E GAMING II Rear I/O Cover LED connector

14. OLED connector

The OLED connector allows you to connect the LiveDash OLED panel. The OLED panel provides you a quick overview of the system temperature, power status, and fan speeds when your system boots up.

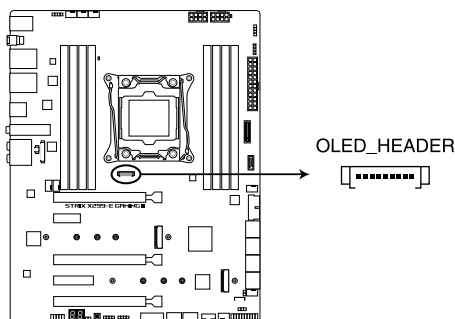

ROG STRIX X299-E GAMING II OLED connector



- Use the **ROG LiveDash Utility** to configure and customize the LiveDash OLED panel.
- The LiveDash OLED displays a Q-Code that provides the most probable cause of an error code as a starting point for troubleshooting. The actual cause may vary from case to case.
- Please refer to the Q-Code table in the **Appendix** section for more details.

15. VROC Key connector

The VROC (Virtual Raid on CPU) Key connector allows you to connect a VROC hardware key to enable additional CPU RAID functions with Intel® CPU RSTe.

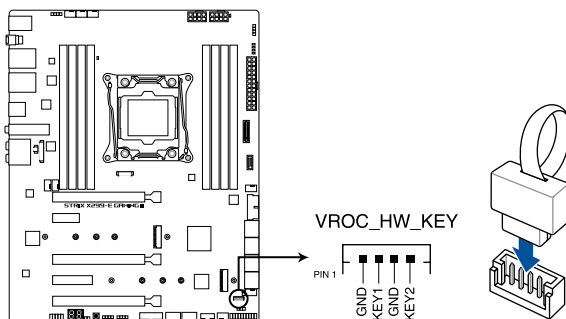

ROG STRIX X299-E GAMING II VROC Key connector



- The VROC hardware key is purchased separately.
- Due to CPU behavior, CPU RAID functions with Intel® CPU RSTe only supports Intel® Core™ X-series Processors (6-core or above) and Intel® SSD modules.

16. Node connector

The Node connector allows you to connect a compatible PSU or control a compatible fan extension card.

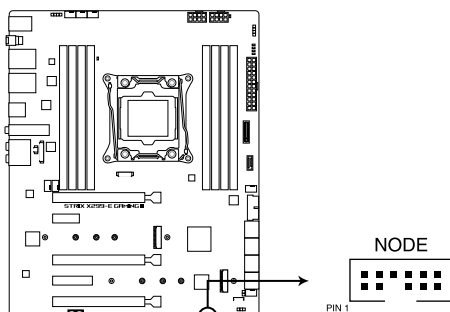

ROG STRIX X299-E GAMING II Node connector



Visit www.asus.com for more information about the devices and the latest compatibility list.

17. Front Panel Audio connector

The front panel audio connector is for a chassis-mounted front panel audio I/O module that supports HD Audio. Connect one end of the front panel audio I/O module cable to this connector.

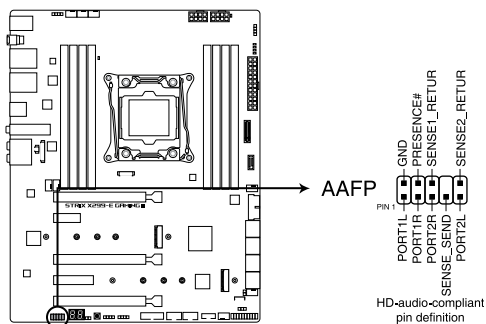

ROG STRIX X299-E GAMING II Front Panel Audio connector



We recommend that you connect a high-definition front panel audio module to this connector to avail of the motherboard's high-definition audio capability.

Basic Installation

2

2.1 Building your PC system



The diagrams in this section are for reference only. The motherboard layout may vary with models, but the installation steps are the same for all models.

2.1.1 CPU and heatsink installation



- Ensure that you install the correct CPU designed for LGA2066 socket only.
- Upon purchase of the motherboard, ensure that the PnP cap is on the socket and the socket contacts are not bent. Contact your retailer immediately if the PnP cap is missing, or if you see any damage to the PnP cap/socket contacts/motherboard components. ASUS will shoulder the cost of repair only if the damage is shipment/transit-related.
- The product warranty does not cover damage to the socket contacts resulting from incorrect CPU installation/removal, or misplacement/loss/incorrect removal of the PnP cap.
- Please note the order in opening/closing the double latch. Follow the instructions printed on the metal sealing hatch or the illustrations shown below in this manual. The plastic cap will pop up automatically once the CPU is in place and the hatch properly sealed down.

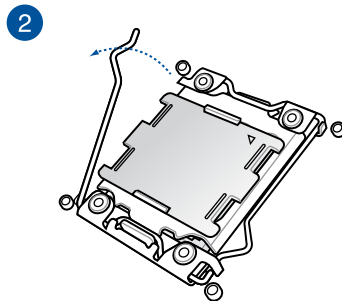
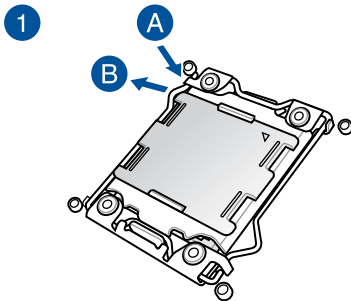

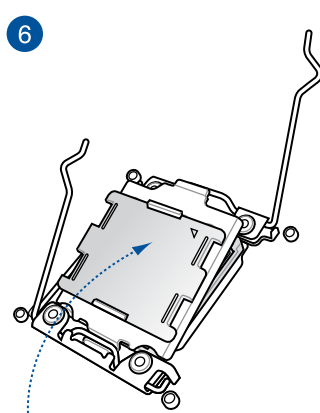
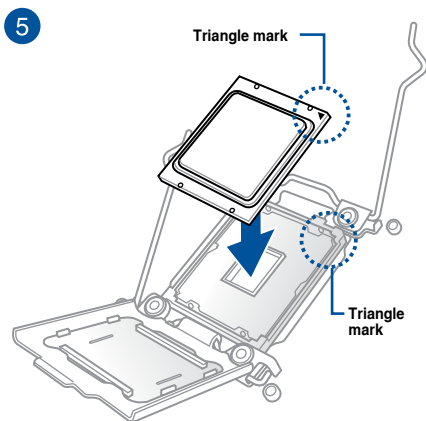
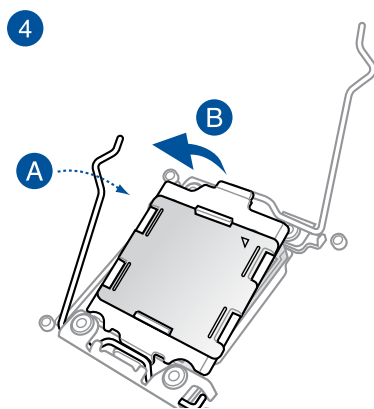
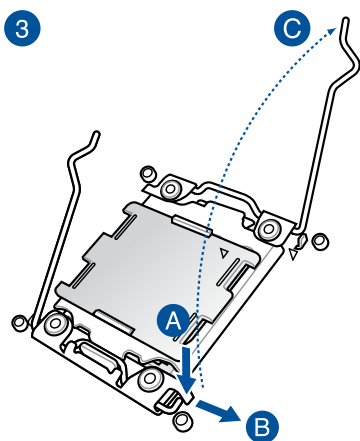

7

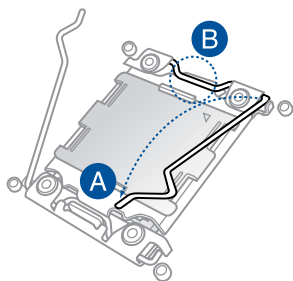

8

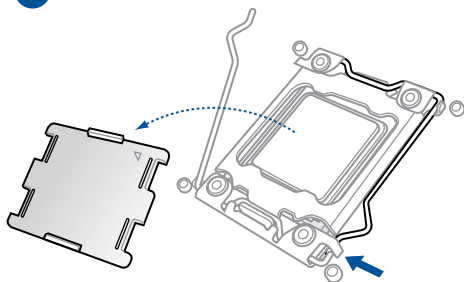

9

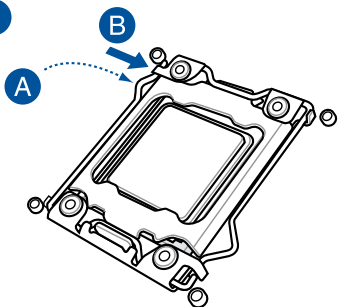

2.1.2 Cooling system installation

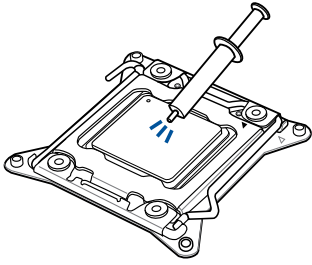

Apply the Thermal Interface Material to the CPU heatsink and CPU before you install the heatsink and fan, if necessary.

To install the CPU heatsink and fan assembly:

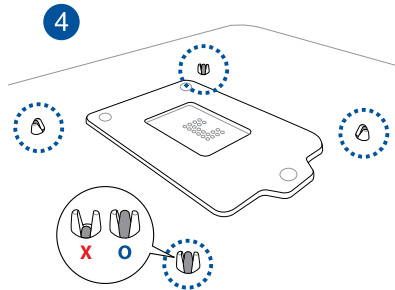
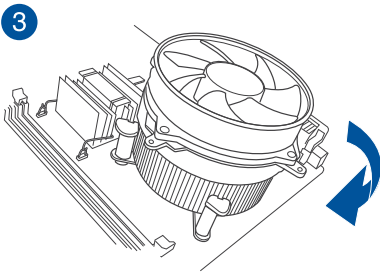
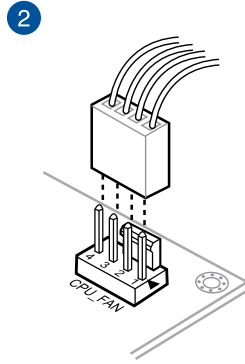
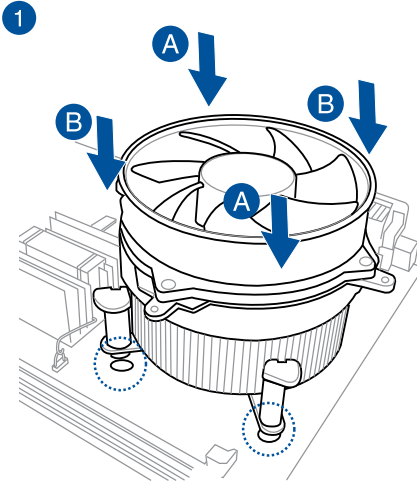

To install a water cooling kit or an AIO cooler

1

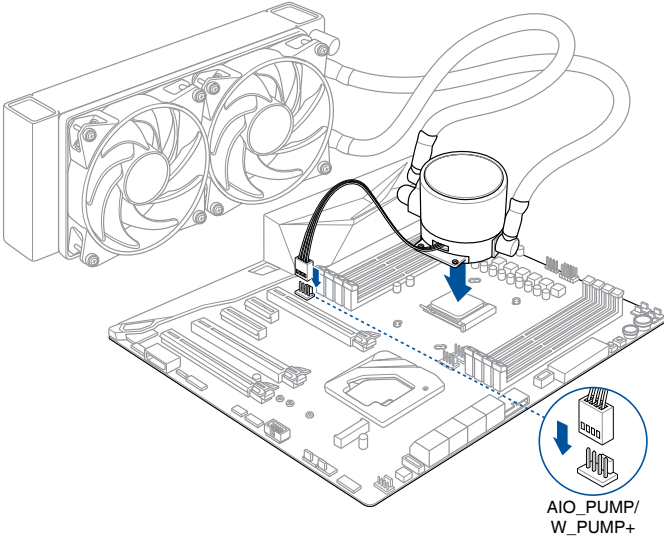

2

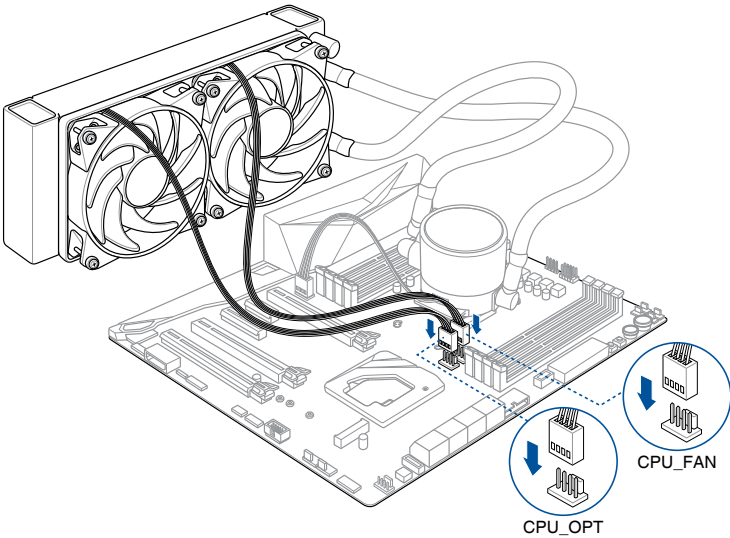

2.1.3 Motherboard installation

1. Place the motherboard into the chassis, ensuring that its rear I/O ports are aligned to the chassis' rear I/O panel.

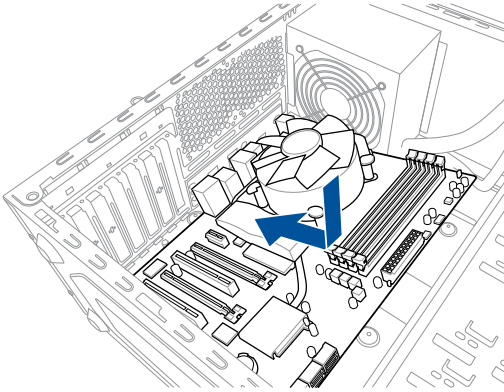

2. Place nine (9) screws into the holes indicated by circles to secure the motherboard to the chassis.

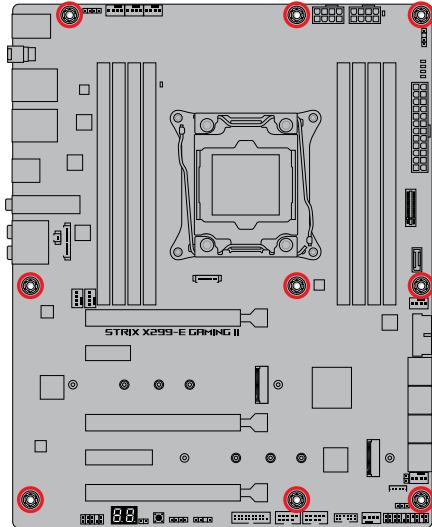
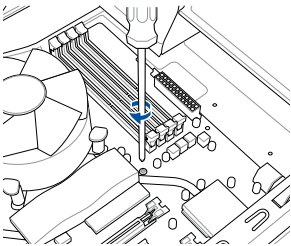

DO NOT overtighten the screws! Doing so can damage the motherboard.

2.1.4 DIMM installation



Ensure to install at least one of the memory modules into the A1+/B1+/C1+/D1+ slots.

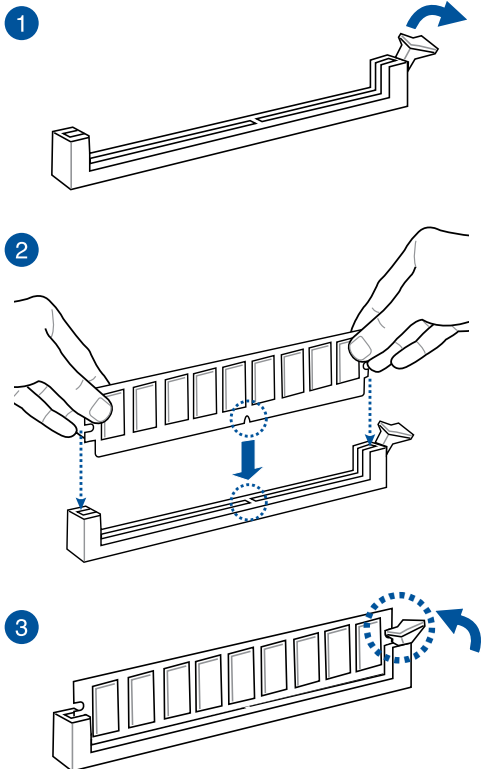

To remove a DIMM

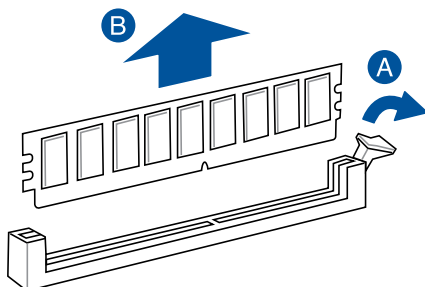

2.1.5 ATX Power connection

1

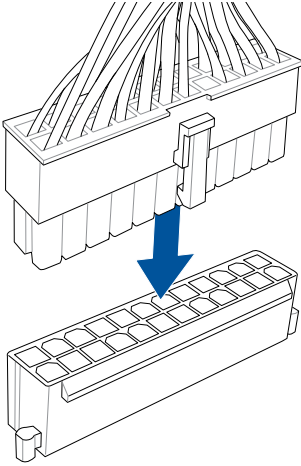

2

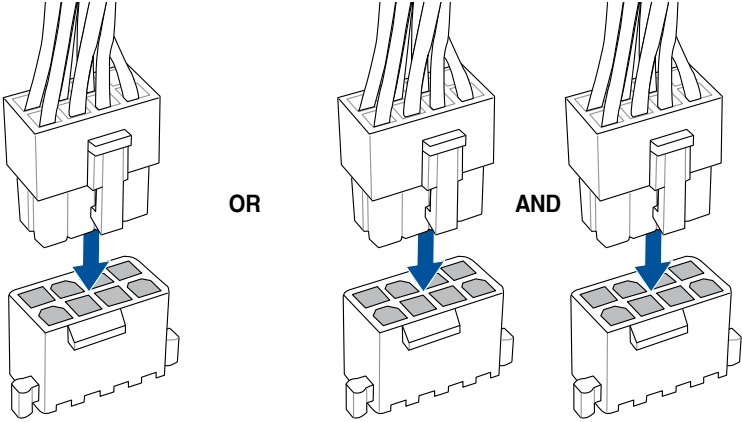

Ensure to connect the 8-pin power plug, or connect both 8-pin power plugs.

2.1.6 SATA device connection

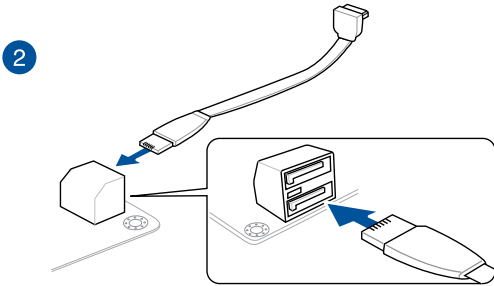
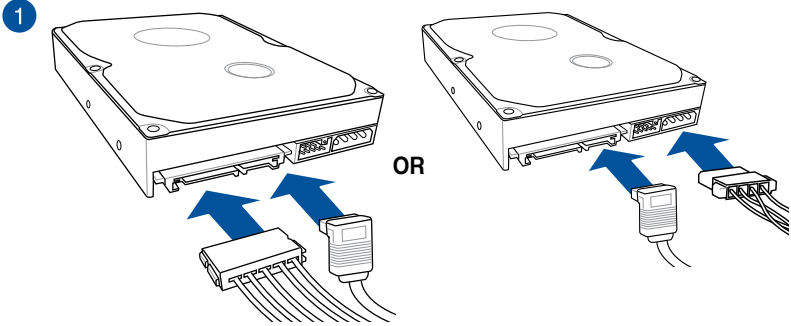

2.1.7 Front I/O connector

To install ASUS Q-Connector

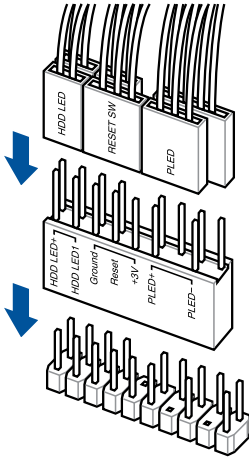

To install USB 3.2 Gen 2 connector

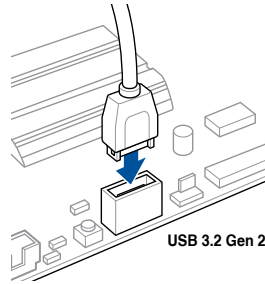

This connector will only fit in one orientation. Push the connector until it clicks into place.

To install USB 3.2 Gen 1 connector

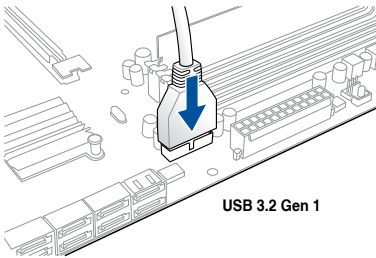

To install USB 2.0 connector

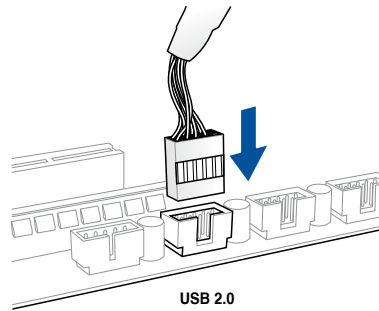

To install front panel audio connector

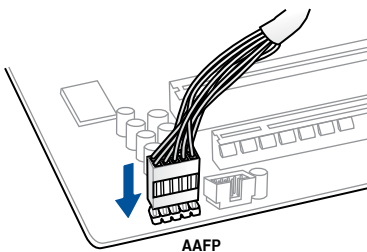

2.1.8 Expansion Card installation

To install PCIe x16 cards

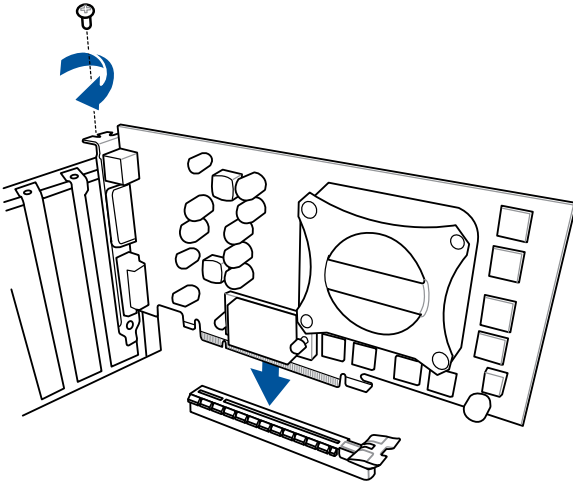

To install PCIe x4 cards

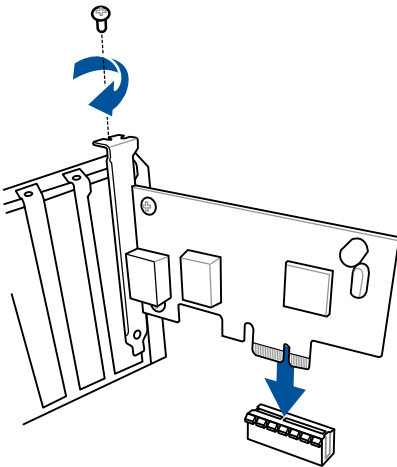

To install PCIe x1 cards

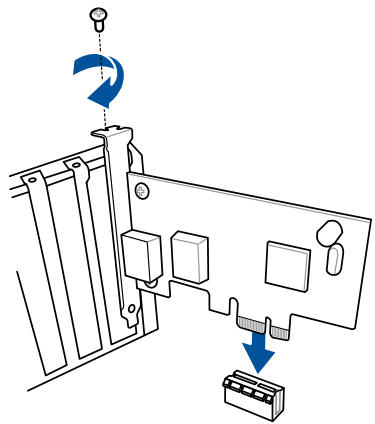

To install FAN EXTENSION CARD II

1

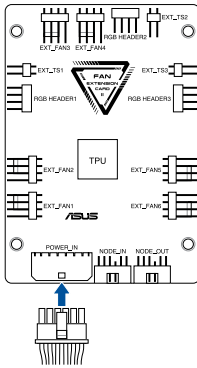

2

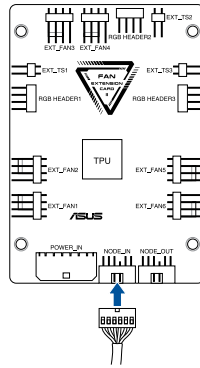

3

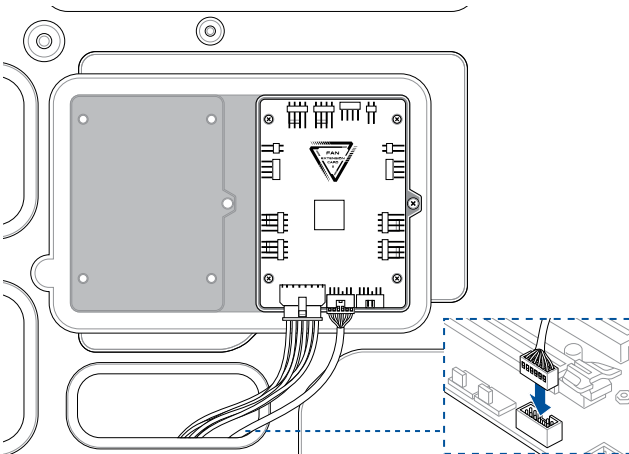

The illustrations in this section are for reference only. The chassis and motherboard layout may vary with models, but the installation steps are the same for all models.

2.1.9 M.2 installation



Supported M.2 type varies per motherboard.

For M.2_1 (Type 2242 / 2260 / 2280 / 22110 M.2)

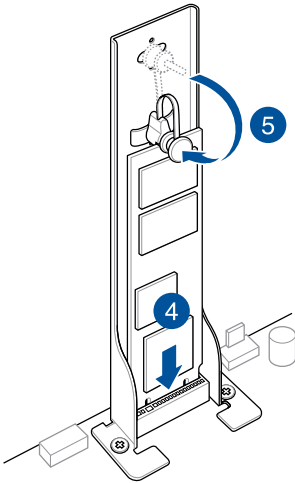
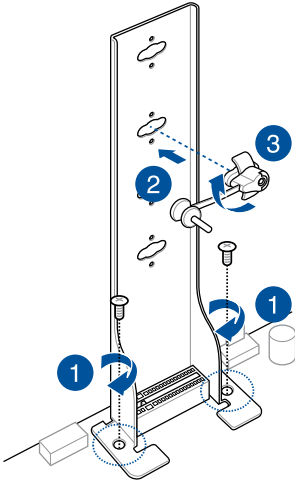

Use the bundled M.2 screws to secure the M.2.

For M.2_2 (Type 2242 / 2260 / 2280 M.2)

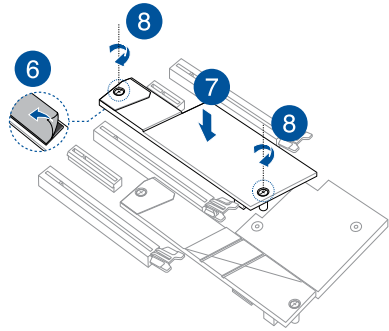
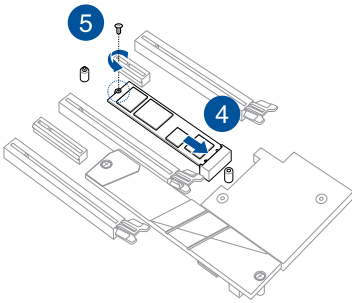
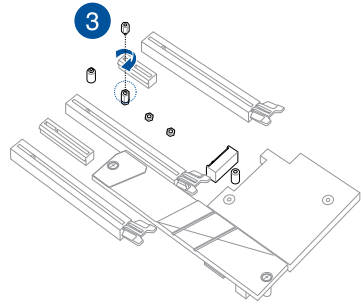
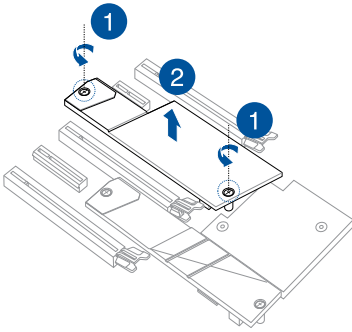

- Please remove the plastic film from the thermal pad before use.
- Use the bundled M.2 screws to secure the M.2.

For M.2_2 (Type 22110 M.2)

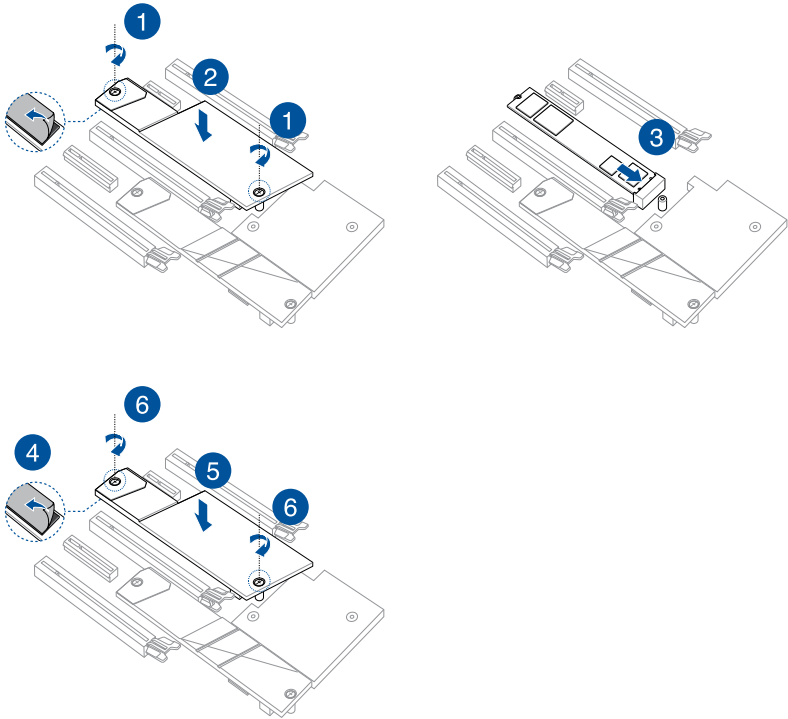

- Please remove the plastic film from the thermal pad before use.
- Use the bundled M.2 screws to secure the M.2.

For M.2_3 (Type 2242 / 2260 / 2280 M.2)

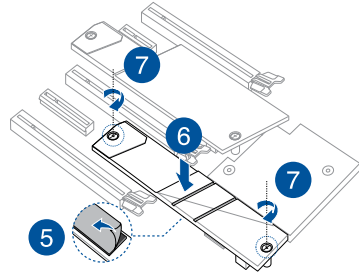
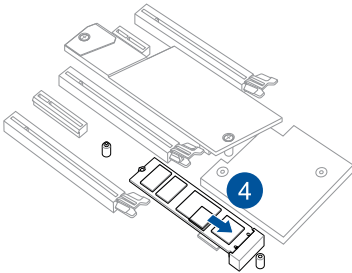
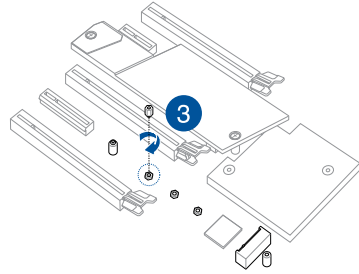
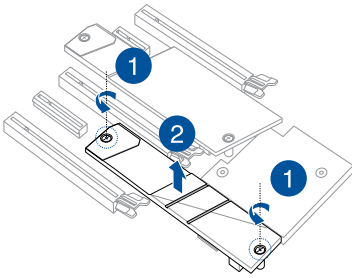

- Please remove the plastic film from the thermal pad before use.
- Use the bundled M.2 screws to secure the M.2.

For M.2_3 (Type 22110 M.2)

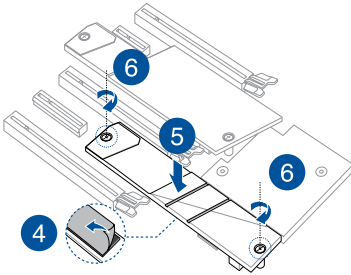
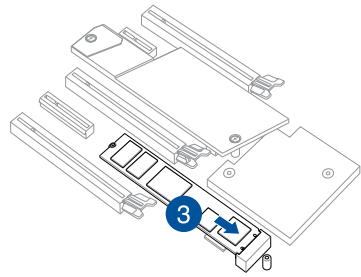
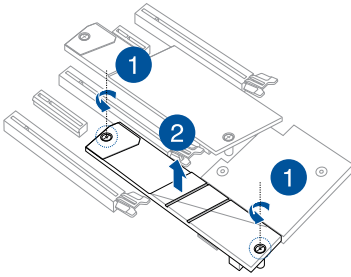

- Please remove the plastic film from the thermal pad before use.
- Use the bundled M.2 screws to secure the M.2.

2.1.10 Wi-Fi antenna installation

Installing the ASUS 2x2 dual band W-Fi antenna

Connect the bundled ASUS 2x2 dual band Wi-Fi antenna connector to the Wi-Fi ports at the back of the chassis.

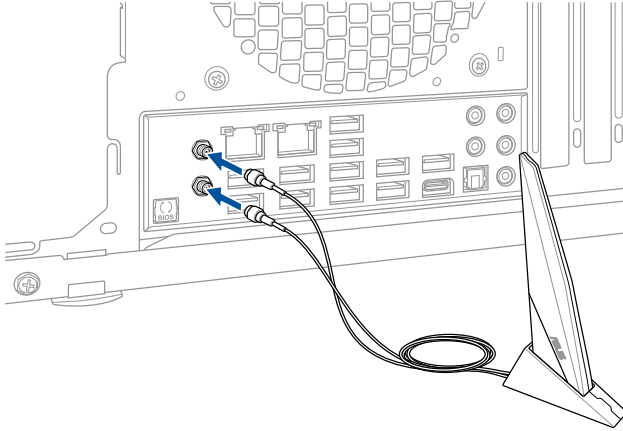

- Ensure that the ASUS 2x2 dual band Wi-Fi antenna is securely installed to the Wi-Fi ports.
- Ensure that the antenna is at least 20 cm away from all persons.



The illustration above is for reference only. The I/O port layout may vary with models, but the Wi-Fi antenna installation procedure is the same for all models.

2.2 BIOS update utility

BIOS FlashBack™

BIOS FlashBack™ allows you to easily update the BIOS without entering the existing BIOS or operating system. Simply insert a USB storage device to the USB port (the USB port hole marked in green on the I/O shield) then press the BIOS FlashBack™ button for three seconds to automatically update the BIOS.

To use BIOS FlashBack™:

1. Insert a USB storage device to the BIOS FlashBack™ port.



We recommend you to use a USB 2.0 storage device to save the latest BIOS version for better compatibility and stability.

2. Visit <https://www.asus.com/support/> and download the latest BIOS version for this motherboard.
3. Manually rename the file as **X299SE2.CAP**, or launch the **BIOSRenamer.exe** application to automatically rename the file, then copy it to your USB storage device.



The **BIOSRenamer.exe** application is zipped together with your BIOS file when you download a BIOS file for a BIOS FlashBack™ compatible motherboard.

4. Shut down your computer.
5. Press the BIOS FlashBack™ button for three seconds until the BIOS FlashBack™ LED blinks three times, indicating that the BIOS FlashBack™ function is enabled.

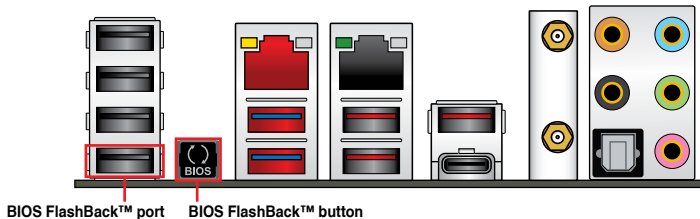

6. Wait until the light goes out, indicating that the BIOS updating process is completed.



For more BIOS update utilities in BIOS setup, refer to the section **Updating BIOS** in Chapter 3.



- Do not unplug portable disk, power system, or press the CLR_CMOS button while BIOS update is ongoing, otherwise update will be interrupted. In case of interruption, please follow the steps again.
 - If the light flashes for five seconds and turns into a solid light, this means that the BIOS FlashBack™ is not operating properly. This may be caused by improper installation of the USB storage device and filename/file format error. If this scenario happens, please restart the system to turn off the light.
 - Updating BIOS may have risks. If the BIOS program is damaged during the process and results to the system's failure to boot up, please contact your local ASUS Service Center.
-

2.3 Motherboard rear and audio connections

2.3.1 Rear I/O connection

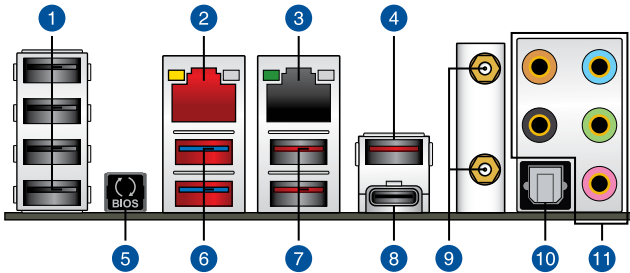

Rear panel connectors

1. USB 2.0 ports 9–12 (Bottom port supports BIOS FlashBack™)	7. USB 3.2 Gen 2 ports E34
2. Intel® LAN port*	8. USB 3.2 Gen 2 Type-C™ port EC1
3. Realtek® 2.5G LAN port*	9. Wi-Fi 802.11 a/b/g/n/ac/ax, Bluetooth V5.0
4. USB 3.2 Gen 2 port E2	10. Optical S/PDIF Out port
5. BIOS FlashBack™ button	11. Audio I/O ports**
6. USB 3.2 Gen 1 ports 56	

* and **: Refer to the tables on the next page for LAN port LEDs and audio port definitions.



We strongly recommend that you connect your devices to ports with matching data transfer rate. Please connect your USB 3.2 Gen 1 devices to USB 3.2 Gen 1 ports and your USB 3.2 Gen 2 devices to USB 3.2 Gen 2 ports for faster and better performance for your devices.

* LAN ports LED indications

Activity Link LED		Speed LED	
Status	Description	Status	Description
Off	No link	Off	10 Mbps connection
Orange	Linked	Orange	100 Mbps connection
Orange (Blinking)	Data activity	Green	1 Gbps connection
Orange (Blinking then steady)	Ready to wake up from S5 mode		

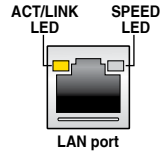

Realtek® RTL8125-CG 2.5G LAN port LED indications

Activity Link LED		Speed LED	
Status	Description	Status	Description
OFF	No link	OFF	100 Mbps connection
GREEN	Linked	GREEN	2.5 Gbps connection
BLINKING	Data activity	ORANGE	1 Gbps / 100 Mbps / 10 Mbps connection

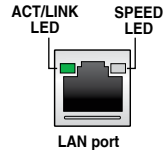

** Audio 2, 4, 5.1 or 7.1-channel configuration

Port	Headset 2-channel	4.channel	5.1-channel	7.1-channel
Light Blue	Line In	Line In	Line In	Side Speaker Out
Lime	Line Out	Front Speaker Out	Front Speaker Out	Front Speaker Out
Pink	Mic In	Mic In	Mic In	Mic In
Orange	–	–	Center/Sub woofer	Center/Sub woofer
Black	–	Rear Speaker Out	Rear Speaker Out	Rear Speaker Out

2.3.2 Audio I/O connections

Audio I/O ports

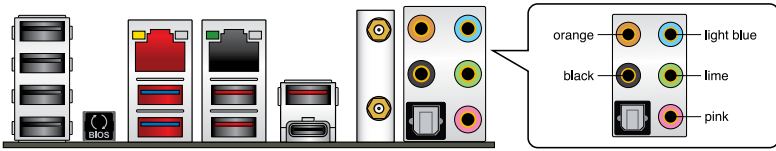

Connect to Headphone and Mic



Connect to Stereo Speakers

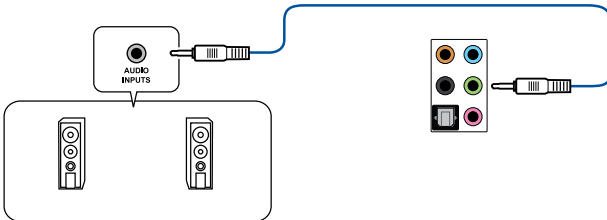

Connect to 2 channel Speakers

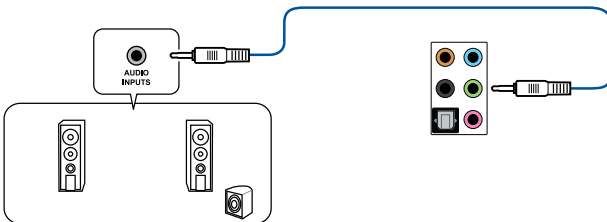

Connect to 4 channel Speakers

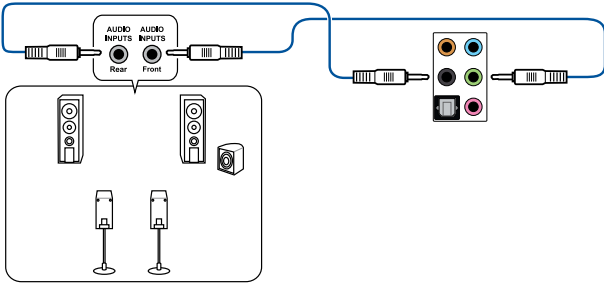

Connect to 6 channel Speakers

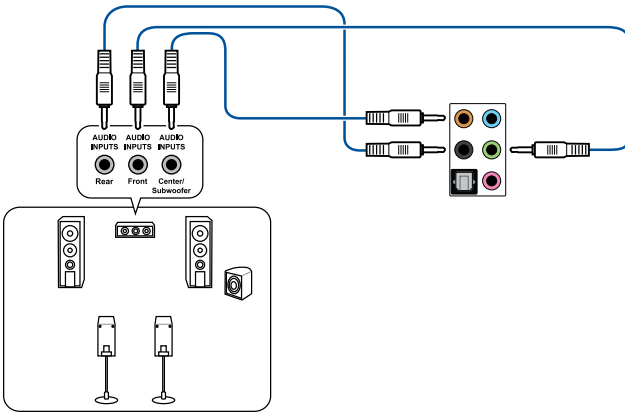

Connect to 8 Speakers

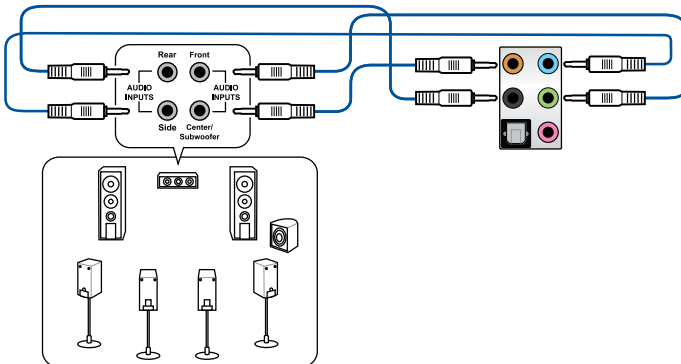

2.4 Starting up for the first time

1. After making all the connections, replace the system case cover.
2. Ensure that all switches are off.
3. Connect the power cord to the power connector at the back of the system chassis.
4. Connect the power cord to a power outlet that is equipped with a surge protector.
5. Turn on the devices in the following order:
 - a. Monitor
 - b. External SCSI devices (starting with the last device on the chain)
 - c. System power
6. After applying power, the system power LED on the system front panel case lights up. For systems with ATX power supplies, the system LED lights up when you press the ATX power button. If your monitor complies with the “green” standards or if it has a “power standby” feature, the monitor LED may light up or change from orange to green after the system LED turns on.

The system then runs the power-on self tests (POST). While the tests are running, the BIOS beeps (refer to the BIOS beep codes table) or additional messages appear on the screen. If you do not see anything within 30 seconds from the time you turned on the power, the system may have failed a power-on test. Check the jumper settings and connections or call your retailer for assistance.

BIOS Beep	Description
One short beep	VGA detected Quick boot set to disabled No keyboard detected
One continuous beep followed by two short beeps then a pause (repeated)	No memory detected
One continuous beep followed by three short beeps	No VGA detected
One continuous beep followed by four short beeps	Hardware component failure

7. At power on, hold down the <Delete> key to enter the BIOS Setup. Follow the instructions in Chapter 3.

2.5 Turning off the computer

While the system is ON, press the power button for less than four seconds to put the system on sleep mode or soft-off mode, depending on the BIOS setting. Press the power switch for more than four seconds to let the system enter the soft-off mode regardless of the BIOS setting.

BIOS Setup

3

3.1 Knowing BIOS



The new ASUS UEFI BIOS is a Unified Extensible Interface that complies with UEFI architecture, offering a user-friendly interface that goes beyond the traditional keyboard-only BIOS controls to enable a more flexible and convenient mouse input. You can easily navigate the new UEFI BIOS with the same smoothness as your operating system. The term "BIOS" in this user manual refers to "UEFI BIOS" unless otherwise specified.

BIOS (Basic Input and Output System) stores system hardware settings such as storage device configuration, overclocking settings, advanced power management, and boot device configuration that are needed for system startup in the motherboard CMOS. In normal circumstances, the default BIOS settings apply to most conditions to ensure optimal performance. **DO NOT change the default BIOS settings** except in the following circumstances:

- An error message appears on the screen during the system bootup and requests you to run the BIOS Setup.
- You have installed a new system component that requires further BIOS settings or update.



Inappropriate BIOS settings may result to instability or boot failure. **We strongly recommend that you change the BIOS settings only with the help of a trained service personnel.**



When downloading or updating the BIOS file, rename it as **X299SE2.CAP** for this motherboard.

3.2 BIOS setup program

Use the BIOS Setup to update the BIOS or configure its parameters. The BIOS screen include navigation keys and brief onscreen help to guide you in using the BIOS Setup program.

Entering BIOS at startup

To enter BIOS Setup at startup, press <Delete> or <F2> during the Power-On Self Test (POST). If you do not press <Delete> or <F2>, POST continues with its routines.

Entering BIOS Setup after POST

To enter BIOS Setup after POST:

- Press <Ctrl>+<Alt>+<Delete> simultaneously.
- Press the reset button on the system chassis.
- Press the power button to turn the system off then back on. Do this option only if you failed to enter BIOS Setup using the first two options.

After doing either of the three options, press <Delete> key to enter BIOS.



-
- The BIOS setup screens shown in this section are for reference purposes only, and may not exactly match what you see on your screen.
 - Ensure that a USB mouse is connected to your motherboard if you want to use the mouse to control the BIOS setup program.
 - If the system becomes unstable after changing any BIOS setting, load the default settings to ensure system compatibility and stability. Select the **Load Optimized Defaults** item under the **Exit** menu or press hotkey <F5>. See section **Exit Menu** for details.
 - If the system fails to boot after changing any BIOS setting, try to clear the CMOS and reset the motherboard to the default value. See section **Onboard jumpers** for information on how to erase the RTC RAM via the Clear CMOS jumper.
 - The BIOS setup program does not support the Bluetooth devices.
-



Please visit ASUS website for the detailed BIOS content manual.

BIOS menu screen

The BIOS Setup program can be used under two modes: **EZ Mode** and **Advanced Mode**. You can change modes from **Setup Mode** in **Boot menu** or by pressing the <F7> hotkey.

3.2.1 Advanced Mode

The Advanced Mode provides advanced options for experienced end-users to configure the BIOS settings. The figure below shows an example of the Advanced Mode. Refer to the following sections for the detailed configurations.



The default screen for entering the BIOS setup program can be changed. Refer to the **Setup Mode** item in section **Boot menu** for details.

The screenshot shows the ASUS UEFI BIOS Advanced Mode interface. The top bar includes the date and time (10/01/2019, 02:19), language (English), and various utility icons like MyFavorite(F3), Qfan Control(F6), AI OC Guide(F11), Search(F9), and AURA ON/OFF(F4). The main menu includes My Favorites, Main, Ai Tweaker (selected), Advanced, Monitor, Boot, Tool, and Exit. The Ai Tweaker section contains settings for Target CPU Turbo-Mode Frequency (4500MHz), Target CPU @ AVX Frequency (4000MHz), Target CPU @ AVX-512 Frequency (4000MHz), Target DRAM Frequency (2133MHz), and Target Cache Frequency (2400MHz). The Ai Overclock Tuner is set to Auto, with options for Manual and XMP. The CPU Core Ratio is set to By Core Usage. The Hardware Monitor section displays CPU/Memory statistics, including Frequency (3300 MHz), Temperature (42°C), Core Voltage (0.938 V), and DRAM Frequency (2133 MHz). The Prediction section shows V-Freq for 4500MHz (2Core Load Stable), 1.184 V (4774 MHz), Heavy AVX (4Core Load Stable), 3808 MHz (4707 MHz), and ALLCore Load (8Core Load Stable).

Labels in the image point to various features:

- Configuration fields**: Points to the top utility icons.
- Pop-up Menu**: Points to the My Favorites menu.
- Menu bar**: Points to the top navigation tabs (Main, Ai Tweaker, etc.).
- Language**: Points to the English language selector.
- MyFavorite(F3)**: Points to the MyFavorite icon.
- Qfan Control(F6)**: Points to the Qfan Control icon.
- AI OC Guide(F11)**: Points to the AI OC Guide icon.
- Search(F9)**: Points to the Search icon.
- Scroll bar**: Points to the AURA ON/OFF icon.
- AURA ON/OFF(F4)**: Points to the AURA ON/OFF icon.
- Menu items**: Points to the top navigation tabs.
- General help**: Points to the information icon (i) in the bottom left.
- Last modified settings**: Points to the Last Modified text at the bottom.
- EZ Tuning Wizard**: Points to the EZ Tuning Wizard icon.
- Go back to EZ Mode**: Points to the EzMode(F7) icon.
- Search on the FAQ**: Points to the Search on FAQ icon.
- Displays a quick overview of the system status and prediction**: Points to the Hardware Monitor section.

Menu bar

The menu bar on top of the screen has the following main items:

My Favorites	For saving the frequently-used system settings and configuration.
Main	For changing the basic system configuration
Ai Tweaker	For changing the overclocking settings
Advanced	For changing the advanced system settings
Monitor	For displaying the system temperature, power status, and changing the fan settings.
Boot	For changing the system boot configuration
Tool	For configuring options for special functions
Exit	For selecting the exit options and loading default settings

Menu items

The highlighted item on the menu bar displays the specific items for that menu. For example, selecting **Main** shows the Main menu items.

The other items (My Favorites, Ai Tweaker, Advanced, Monitor, Boot, Tool, and Exit) on the menu bar have their respective menu items.

Submenu items

A greater than sign (>) before each item on any menu screen means that the item has a submenu. To display the submenu, select the item and press <Enter>.

Language

This button above the menu bar contains the languages that you can select for your BIOS. Click this button to select the language that you want to display in your BIOS screen.

My Favorites(F3)

This button above the menu bar shows all BIOS items in a Tree Map setup. Select frequently-used BIOS settings and save it to MyFavorites menu.



Refer to section **My Favorites** for more information.

Q-Fan Control(F6)

This button above the menu bar displays the current settings of your fans. Use this button to manually tweak the fans to your desired settings.



Refer to section **QFan Control** for more information.

AI OC Guide(F11)

This button above the menu bar allows you to view the descriptions of AI overclocking and enable it.



-
- Refer to section **AI OC Guide** for more information.
 - This function is only enabled when using an unlocked CPU.
-

Search (F9)

This button allows you to search for BIOS items by entering its name, enter the item name to find the related item listing.

AURA (F4)

This button allows you to turn the RGB LED lighting or functional LED on or off.

[All On]: All LEDs (Aura or Functional) will be enabled.

[Aura Only]: Aura LEDs will be enabled and functional LEDs will be disabled.

[Aura Off]: Aura LEDs will be disabled, however functional LEDs will still be enabled.

[Stealth Mode]: All LEDs (Aura and Functional) will be disabled.

Search on FAQ

Move your mouse over this button to show a QR code, scan this QR code on your mobile device to connect to the BIOS FAQ web page of the ASUS support website. You can also scan the following QR code:



Scroll bar

A scroll bar appears on the right side of a menu screen when there are items that do not fit on the screen. Press the Up/Down arrow keys or <Page Up> / <Page Down> keys to display the other items on the screen.

General help

At the bottom of the menu screen is a brief description of the selected item. Use <F12> key to capture the BIOS screen and save it to the removable storage device.

Configuration fields

These fields show the values for the menu items. If an item is user-configurable, you can change the value of the field opposite the item. You cannot select an item that is not user-configurable.

A configurable field is highlighted when selected. To change the value of a field, select it and press <Enter> to display a list of options.

Hot keys

This button contains the navigation keys for the BIOS setup program. Use the navigation keys to select items in the menu and change the settings.

EZ Tuning Wizard

This button allows you to view and configure the RAID settings of your system.



Refer to section **EZ Tuning Wizard** for more information.

Last Modified button

This button shows the items that you last modified and saved in BIOS Setup.

3.2.2 EZ Mode

The EZ Mode provides you an overview of the basic system information, and allows you to select the display language, system performance, mode and boot device priority. To access the Advanced Mode, select **Advanced Mode** or press the <F7> hotkey for the advanced BIOS settings.



To switch from Advanced Mode to EZ Mode, click **EZ Mode(F7)** or press the <F7> hotkey.

Displays a quick overview of the system status

Displays the system properties of the selected mode. Click < or > to switch modes

EZ Tuning Wizard

Selects the display language of the BIOS setup program

AI OC Guide(F11) Search(F9) AURA ON/OFF(F4)

Information

CPU Temperature

CPU Core Voltage

AI Overclocking

DRAM Status

Storage Information

Intel Rapid Storage Technology

CPU FAN

FAN Profile

Boot Priority

Default(F5) Save & Exit(F10) Advanced Mode(F7) |<|> Search on FAQ

Enables or disables the SATA RAID mode for Intel Rapid Storage Technology

Displays the CPU Fan's speed. Click the button to manually tune the fans

Loads optimized default settings

Saves the changes and resets the system

Click to go to Advanced mode

Search on the FAQ

Click to display boot devices

Selects the boot device priority



The boot device options vary depending on the devices you installed to the system.

3.2.3 QFan Control

The QFan Control allows you to set a fan profile or manually configure the operating speed of your CPU and chassis fans.

The screenshot shows the Q-Fan Control interface with the following annotations:

- Click to select a fan to be configured**: Points to the fan selection list on the left.
- Click to activate PWM Mode**: Points to the 'Standard' profile in the slider.
- Click to activate DC Mode**: Points to the 'Manual' profile in the slider.
- Select a profile to apply to your fans**: Points to the 'Standard' profile in the slider.
- Click to undo the changes**: Points to the 'Undo' button.
- Click to apply the fan setting**: Points to the 'Apply' button.
- Click to go back to main menu**: Points to the 'Exit (ESC)' button.
- Select to manually configure your fans**: Points to the 'Manual' profile in the slider.

The interface includes a fan selection list, a graph showing fan speed (%) vs temperature (°C), a profile slider, and control buttons.

Temperature (°C)	Fan Speed (%)
0	60
30	60
70	100
100	100

Configuring fans manually

Select **Manual** from the list of profiles to manually configure your fans' operating speed.

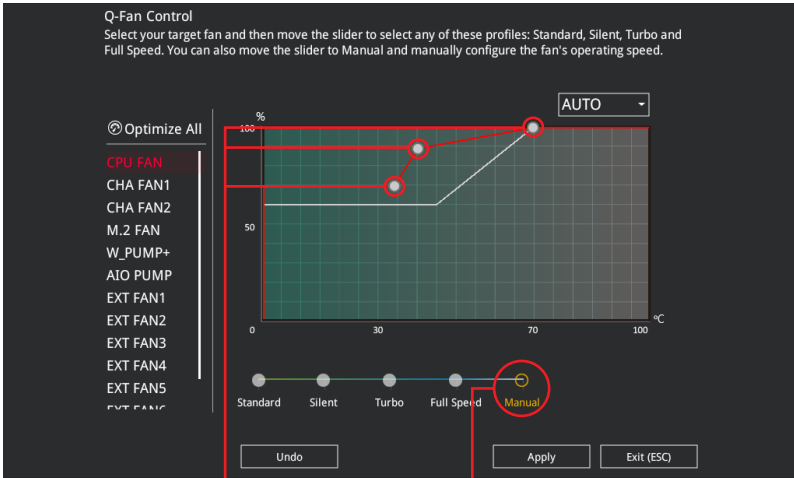

Speed points

Select to manually
configure your fans

To configure your fans:

1. Select the fan that you want to configure and to view its current status.
2. Click and drag the speed points to adjust the fans' operating speed.
3. Click **Apply** to save the changes then click **Exit (ESC)**.

3.2.4 AI OC Guide



- The screenshot shown in this section is for reference purposes only, and may not exactly match what you see on your screen.
- This function is only enabled when using an unlocked CPU.

The AI OC Guide allows you to enable the AI Overclocking feature, or view a quick guide of the AI Overclocking feature which highlights the recommended setup procedure and descriptions of the AI Overclocking.

Clicking on **Enable AI** will enable AI Overclocking.

The screenshot shows the 'AI Overclocking Guide' interface. On the left is a navigation pane with a red box highlighting the following text:

- Introduction
- About the AI Overclocking monitor pane in UEFI
- The AI Overclocking feature
- The following options are found within Extreme Tweaker> AI Features

On the right side of the UEFI window, a variety of AI Overclocking stats are shown. This portion of the guide explains what each item means. SP represents an assessment of the current platform.

Cooler Score refers to the efficiency of the cooler. Depending upon configuration of the "Cooler efficiency customizer" function, this value changes as data is collected by the motherboard. Contributing factors to the score include CPU Core temperatures, processor leakage, ambient temperatures, and CPU fan speeds. Typically, an air-cooler scores around 130pts, an AIO 150-160, and a custom water-loop around 170+ (ambient temps of 26 Celsius).

V req for target refers to the minimum voltage required for the target CPU frequency during normal (non-AVX) workloads. The value is based on Prime95 small FFT stability and referenced off the worst core.

2core Load Stable refers to the frequency sustainable when 2 cores are under load.

4core Load Stable refers to the frequency sustainable when 4 cores are under load.

8core Load Stable refers to the frequency sustainable when 8 cores are under load. Only applicable if there are more than 10cores.

Allcore Load Stable refers to the frequency sustainable when all cores are under load.

Heavy AVX Stable refers to the frequency sustainable when all cores are under load in heavy AVX workloads such as blender.

At the bottom of the guide are four buttons: 'Previous', 'Next', 'Enable AI', and 'Cancel'. Red lines connect these buttons to descriptive text below:

- Quick guide topics** (points to the navigation pane)
- Click to view the previous topic in the quick guide** (points to 'Previous')
- Click to view the next topic in the quick guide** (points to 'Next')
- Click to enable AI Overclocking** (points to 'Enable AI')
- Click to go back to main menu** (points to 'Cancel')

3.2.5 EZ Tuning Wizard

EZ Tuning Wizard allows you to easily set RAID in your system using this feature.

Creating RAID

To create RAID:

1. Click **EZ Tuning Wizard** from the BIOS screen to open EZ Tuning Wizard screen.
2. Click **RAID** then select the port that you want to set to [RAID] mode, **CPU**, **PCH** or **SATA**, then click **Next**.



- Ensure that your HDDs have no existing RAID volumes.
- Ensure to connect your HDDs to Intel® SATA connectors.

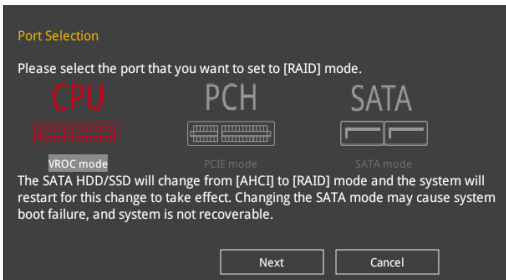

3. Select **Yes** to enable RAID.



4. Click **Next** to proceed.



5. Select the type of storage for your RAID, **Easy Backup** or **Super Speed**, then click **Next**.

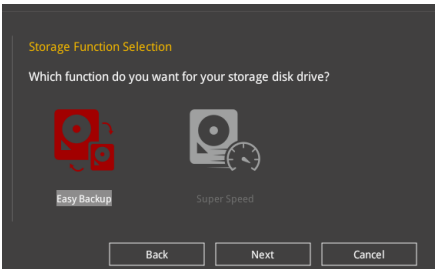

- a. For Easy Backup, click **Next** then select from **Easy Backup (RAID 1)** or **Easy Backup (RAID 10)**.

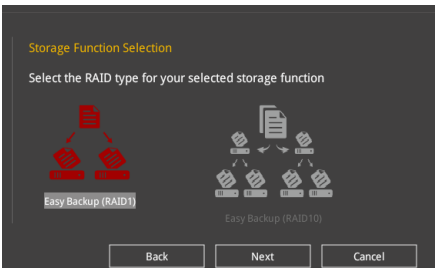

You can only select Easy Backup (RAID 10) if you connect four (4) HDDs.

- b. For Super Speed, click **Next** then select from **Super Speed (RAID 0)** or **Super Speed (RAID 5)**.

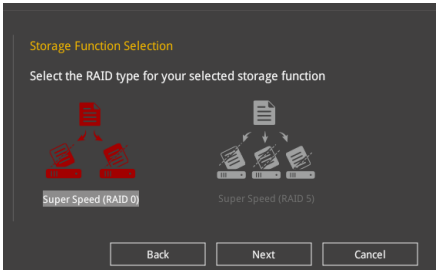

6. After selecting the type of RAID, click **Next** then click **Yes** to continue the RAID setup.
7. After the RAID setup is done, click **Yes** to exit the setup then click **OK** to reset your system.

3.3 My Favorites

My Favorites is your personal space where you can easily save and access your favorite BIOS items.

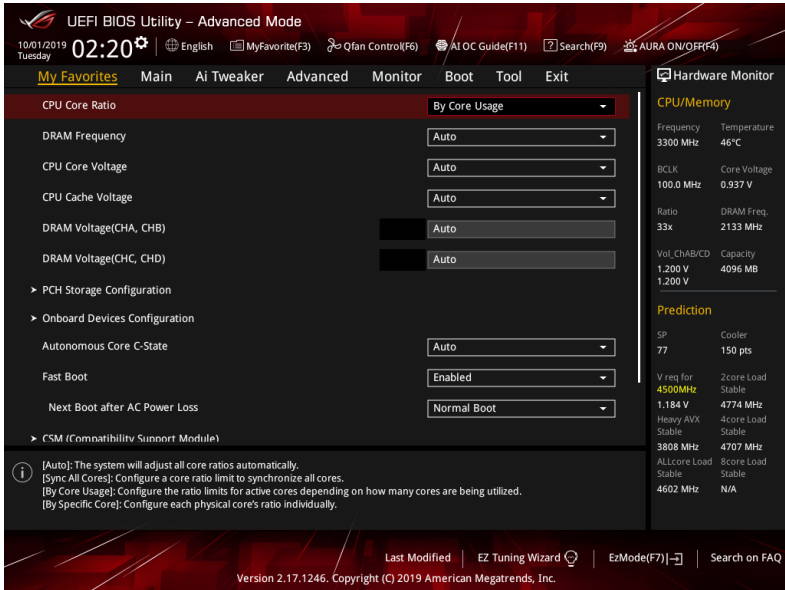

My Favorites comes with several performance, power saving, and fast boot related items by default. You can personalize this screen by adding or removing items.

Adding items to My Favorites

To add BIOS items:

1. Press <F3> on your keyboard or click **MyFavorite(F3)** from the BIOS screen to open Setup Tree Map screen.
2. On the Setup Tree Map screen, select the BIOS items that you want to save in My Favorites screen.

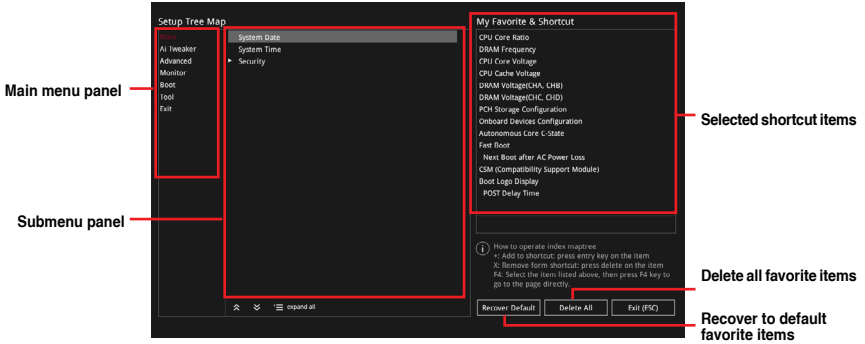

3. Select an item from main menu panel, then click the submenu that you want to save as favorite from the submenu panel and click **+** or press <Enter> on your keyboard.



You cannot add the following items to My Favorite items:

- Items with submenu options
- User-managed items such as language and boot order
- Configuration items such as Memory SPD Information, system time and date.

4. Click **Exit (ESC)** or press <Esc> key to close Setup Tree Map screen.
5. Go to My Favorites menu to view the saved BIOS items.

3.4 Main menu

The Main menu screen appears when you enter the Advanced Mode of the BIOS Setup program. The Main menu provides you an overview of the basic system information, and allows you to set the system date, time, language, and security settings.

Security

The Security menu items allow you to change the system security settings.



- If you have forgotten your BIOS password, erase the CMOS Real Time Clock (RTC) RAM to clear the BIOS password. See section **Onboard jumpers** for information on how to erase the RTC RAM via the Clear CMOS jumper.
- The Administrator or User Password items on top of the screen show the default **[Not Installed]**. After you set a password, these items show **[Installed]**.

3.5 Ai Tweaker menu

The Ai Tweaker menu items allow you to configure overclocking-related items.



Be cautious when changing the settings of the Ai Tweaker menu items. Incorrect field values can cause the system to malfunction



The configuration options for this section vary depending on the CPU and DIMM model you installed on the motherboard.

Ai Overclock Tuner

Allows you to select the CPU overclocking options to achieve the desired CPU internal frequency. Configuration options:

- | | |
|----------|---|
| [Auto] | Loads the optimal settings for the system. |
| [Manual] | Allows you to individually set overclocking parameters. |
| [X.M.P.] | If you install memory modules supporting the eXtreme Memory Profile (X.M.P.) Technology, choose this item to set the profiles supported by your memory modules for optimizing the system performance. |



The [X.M.P.] configuration option appears only when you install memory modules supporting the eXtreme Memory Profile(X.M.P.) Technology.



The following item appears only when **Ai Overclocking Tuner** is set to **[Manual]**.

BCLK Frequency

This item allows you to set the BCLK (base clock) frequency to enhance the system performance. Use the <+> or <-> to adjust the value. The values range from 80.0 MHz to 300.0 MHz.



We recommend you to set the value based on the CPU specification, as high BCLK frequencies may damage the CPU permanently.

ASUS MultiCore Enhancement

[Auto] This item allows you to maximize the overclocking performance optimized by ASUS core ratio settings.

[Disabled] This item allows you to set to default core ratio settings.

CPU Core Ratio

This item allows you to set the CPU core ratios.

Configuration options: [Auto] [Sync All Cores] [By Core Usage] [By Specific Core]

[AI Optimized]

BCLK Frequency : DRAM Frequency Ratio

[Auto] The BCLK frequency to DRAM frequency ratio will be set to the optimized setting.

[100:133] The BCLK frequency to DRAM frequency ratio will be set to 100:133.

[100:100] The BCLK frequency to DRAM frequency ratio will be set to 100:100.

DRAM Frequency

This item allows you to set the memory operating frequency. The configurable options vary with the BCLK (base clock) frequency setting. Select the auto mode to apply the optimized setting.

Configuration options: [Auto] [DDR4-800MHz] - [DDR4-4400MHz]

Internal CPU Power Management

The subitems in this menu allow you to set the CPU ratio and features.

Enhanced Intel SpeedStep Technology

Allows the operating system to dynamically adjust the processor voltage and cores frequency to decrease the average power consumption and decrease average heat production.

Configuration options: [Auto] [Disabled] [Enabled]

Turbo Mode

Allows you to enable your processor cores to run faster than the base operating frequency when it is below power, current and specification limit.

Configuration options: [Disabled] [Enabled]

3.6 Advanced menu

The Advanced menu items allow you to change the settings for the CPU and other system devices.



Be cautious when changing the settings of the Advanced menu items. Incorrect field values can cause the system to malfunction.

3.6.1 CPU Configuration

The items in this menu show the CPU-related information that the BIOS automatically detects.



The items in this menu may vary based on the CPU installed.

Hyper-threading [ALL]

This item allows a hyper-threading processor to appear as two logical processors, allowing the operating system to schedule two threads or processors simultaneously.

Configuration options: [Disabled] [Enabled]

CPU - Power Management Control

This item allows you to manage and configure the CPU's power.

Enhanced Intel SpeedStep Technology

This item allows more than two frequency to be supported.

Configuration options: [Disabled] [Enabled]

Turbo Mode

This item allows you to automatically set the CPU cores to run faster than the base operating frequency when it is below the operating power, current and temperature specification limit.

Configuration options: [Disabled] [Enabled]

Autonomous Core C-State

This item allows you to enable or disable Autonomous Core C-State Control.

Configuration options: [Auto] [Disabled] [Enabled]

3.6.2 Platform Misc Configuration

The items in this menu allow you to change the ASPM for PCH and SA PCI Express.

3.6.3 System Agent (SA) Configuration

The items in this menu allow you to adjust the Link Speed for PEG Port and Multi-Monitor.

3.6.4 PCH Configuration

The items in this menu allow you to adjust the PCH PCI Express speed.

PCI Express Configuration

This item allows you to configure the PCI Express slots.

PCIe Speed

This item allows your system to automatically select the PCI Express port speed.

Configuration options: [Auto] [Gen1 (2.5 GT/s)] [Gen2 (5 GT/s)] [Gen3 (8 GT/s)]

3.6.5 PCH Storage Configuration

While entering Setup, the BIOS automatically detects the presence of SATA devices. The SATA Port items show **Not Present** if no SATA device is installed to the corresponding SATA port.

SATA Controller(s)

This item allows you to enable or disable the SATA Device.

Configuration options: [Enabled] [Disabled]

SATA Mode Selection

This item allows you to set the SATA configuration.

- | | |
|---------------------------|--|
| [AHCI] | Set to [AHCI] when you want the SATA hard disk drives to use the AHCI (Advanced Host Controller Interface). The AHCI allows the onboard storage driver to enable advanced Serial ATA features that increases storage performance on random workloads by allowing the drive to internally optimize the order of commands. |
| [Intel RST Premium(RAID)] | Set to [Intel RST Premium(RAID)] when you want to create a RAID configuration from the SATA hard disk drives. |

S.M.A.R.T. Status Check

SMART (Self-Monitoring, Analysis and Reporting Technology) is a monitoring system that shows a warning message during POST (Power-on Self Test) when an error occurs in the hard disks.

Configuration options: [On] [Off]

SATA6G_1 - SATA6G_8

SATA6G_1 - SATA6G_8

This item allows you to enable or disable the selected SATA port.

Configuration options: [Disabled] [Enabled]

Hot Plug

These items appears only when the SATA Mode Selection is set to [AHCI] and allows you to enable or disable SATA Hot Plug Support.

Configuration options: [Disabled] [Enabled]

3.6.6 CPU Storage Configuration

The items in this menu allow you to configure CPU storage configurations.



- This menu will appear only when an Intel® Core™ X-series Processors (6-core or above) is installed.
- Due to CPU behavior, CPU RAID functions with Intel® CPU RSTe only supports Intel® Core™ X-series Processors (6-core or above) and Intel® SSD modules.

3.6.7 Onboard Devices Configuration

The items in this menu allow you to switch between PCIe Lanes and configure onboard devices.

HD Audio Controller

This item allows you to use the Azalia High Definition Audio Controller

Configuration options: [Disabled] [Enabled]

USB Type C Power Switch

[Auto] The system will automatically detect your USB Type C devices and provide suitable power if needed.

[Enabled] The USB Type C port will always provide power to your devices.

RGB LED lighting

When system is in working state

This item allows you to turn the RGB LED lighting on or off when the system is in the working state.

Configuration options: [All On] [Stealth Mode] [Aura only] [Aura Off]

Q-Code LED Function

[Disabled] Disable the Q-Code LED.

[Auto] Automatically display POST (Power-On Self-Test) code and CPU temperature on Q-Code LED.

[POST Code Only] Show POST (Power-On Self-Test) code on Q-Code LED.

When system is in sleep, hibernate or soft off states

This item allows you to turn the RGB LED lighting on or off when the system is in the sleep, hibernate or soft off states.

Configuration options: [All On] [Stealth Mode] [Aura only] [Aura Off]

Wi-Fi 6 (802.11ax)

This item allows you to enable or disable the Wi-Fi 6 (802.11ax) controller.

Configuration options: [Disabled] [Enabled]

Intel LAN Controller

This item allows you to enable or disable the Intel LAN controllers.

Configuration options: [Disabled] [Enabled]

Realtek 2.5G LAN Controller

This item allows you to enable or disable the Realtek 2.5G LAN controllers.

Configuration options: [Disabled] [Enabled]

3.6.8 APM Configuration

The items in this menu allow you to set system wake and sleep settings.

ErP Ready

This item allows you to switch off some power at S4+S5 or S5 to get the system ready for ErP requirement. When set to **[Enabled]**, all other PME options are switched off.

Configuration options: [Disabled] [Enable(S4+S5)] [Enable(S5)]

3.6.9 USB Configuration

The items in this menu allow you to change the USB-related features.



The **Mass Storage Devices** item shows the auto-detected values. If no USB device is detected, the item shows **None**.

USB Single Port Control

This item allows you to enable or disable the individual USB ports.



Refer to section **Motherboard layout** for the location of the USB ports.

3.6.10 HDD/SSD SMART Information

This menu displays the SMART information of the connected devices.



NVM Express devices do not support SMART information.

3.6.11 NVMe Configuration

This menu displays the NVMe controller and Drive information of the connected devices.

3.6.12 PCH-FW Configuration

This item allows you to configure the firmware TPM.

3.6.13 Network Stack Configuration

The items in this menu allow you to configure ipv4 / ipv6 PXE support.

3.6.14 Intel(R) Rapid Storage Technology

Allows you to manage RAID volumes on the Intel(R) RAID Controller.

3.7 Monitor menu

The Monitor menu displays the system temperature/power status, and allows you to change the fan settings.

Qfan Configuration

Qfan Tuning

Click this item to automatically detect the lowest speed and configure the minimum duty cycle for each fan.

AIO PUMP/Water PUMP+ Control

- [Disabled] Disable the AIO Pump/Water Pump control feature.
- [Auto] Detects the type of AIO Pump/Water Pump installed and automatically switches the control modes.
- [DC mode] Enable the AIO Pump/Water Pump control in DC mode for 3-pin chassis fan.
- [PWM mode] Enable the AIO Pump/Water Pump control in PWM mode for 4-pin chassis fan.

3.8 Boot menu

The Boot menu items allow you to change the system boot options.

Fast Boot

- [Disabled] Allows your system to go back to its normal boot speed.
- [Enabled] Allows your system to accelerate the boot speed.



The following items appear only when **Fast Boot** is set to **[Enabled]**.

Next Boot after AC Power Loss

- [Normal Boot] Returns to normal boot on the next boot after an AC power loss.
- [Fast Boot] Accelerates the boot speed on the next boot after an AC power loss.

Boot Configuration

Setup Mode

- [Advanced Mode] This item allows you to go to Advanced Mode of the BIOS after POST.
- [EZ Mode] This item allows you to go to EZ Mode of the BIOS after POST.

CSM (Compatibility Support Module)

This item allows you to configure the CSM (Compatibility Support Module) items to fully support the various VGA, bootable devices and add-on devices for better compatibility.

Launch CSM

[Auto]	The system automatically detects the bootable devices and the add-on devices.
[Enabled]	For better compatibility, enable the CSM to fully support the non-UEFI driver add-on devices or the Windows® UEFI mode.
[Disabled]	Disable the CSM to fully support the non-UEFI driver add-on devices or the Windows® UEFI mode.



The following items appear only when **Launch CSM** is set to **[Enabled]**.

Boot Devices Control

This item allows you to select the type of devices that you want to boot.

Configuration options: [UEFI and Legacy OPROM] [Legacy OPROM only] [UEFI only]

Boot from Network Devices

This item allows you to select the type of network devices that you want to launch.

Configuration options: [Ignore] [Legacy only] [UEFI driver first]

Boot from Storage Devices

This item allows you to select the type of storage devices that you want to launch.

Configuration options: [Ignore] [Legacy only] [UEFI driver first]

Boot from PCI-E/PCI Expansion Devices

This item allows you to select the type of PCI-E/PCI expansion devices that you want to launch.

Configuration options: [Legacy only] [UEFI driver first]

Secure Boot

This item allows you to configure the Windows® Secure Boot settings and manage its keys to protect the system from unauthorized access and malwares during POST.

Boot Option Priorities

These items specify the boot device priority sequence from the available devices. The number of device items that appears on the screen depends on the number of devices installed in the system.



- To access Windows® OS in Safe Mode, press <F8> after POST (Windows® 8 not supported).
 - To select the boot device during system startup, press <F8> when the ASUS Logo appears.
-

Boot Override

These items displays the available devices. The number of device items that appears on the screen depends on the number of devices installed in the system. Click an item to start booting from the selected device.

3.9 Tool menu

The Tool menu items allow you to configure options for special functions. Select an item then press <Enter> to display the submenu.

Flexkey

This item allows you to assign a different function to the Reset button (Flexkey).

[Reset] Reboots the system.

[Aura On/Off] Enable or Disable Aura LEDs. This setting does not sync with the BIOS/software option.

[DirectKey] Boot directly into the BIOS.

Setup Animator

This item allows you to enable or disable the Setup animator.

Configuration options: [Enabled] [Disabled]

3.9.1 ASUS EZ Flash 3 Utility

This item allows you to run ASUS EZ Flash 3. When you press <Enter>, a confirmation message appears. Use the left/right arrow key to select between [Yes] or [No], then press <Enter> to confirm your choice.



For more details, refer to section **ASUS EZ Flash 3**.

3.9.2 Secure Erase

SSD speeds may lower over time as with any storage medium due to data processing. Secure Erase completely and safely cleans your SSD, restoring it to factory performance levels.



Secure Erase is only available in AHCI mode. Ensure to set the SATA mode to AHCI. Click **Advanced > PCH Storage Configuration > SATA Mode Selection > AHCI**.

To launch Secure Erase, click **Tool > Secure Erase** on the Advanced mode menu.



Check the ASUS support site for a full list of SSDs tested with Secure Erase. The drive may become unstable if you run Secure Erase on an incompatible SSD.



- The time to erase the contents of your SSD may take a while depending on its size. Do not turn off the system during the process.
- Secure Erase is only supported on Intel SATA port. For more information about Intel SATA ports, refer to section **Motherboard layout** of this manual.

Displays the available SSDs

Port #	SSD Name	Status	Total Capacity
P2	ADATA 5096 Turbo	Frozen	64.0GB



Status definition:

- **Frozen.** The frozen state is the result of a BIOS protective measure. The BIOS guards drives that do not have password protection by freezing them prior to booting. If the drive is frozen, a power off or hard reset of your PC must be performed to proceed with the Secure Erase.
- **Locked.** SSDs might be locked if the Secure Erase process is either incomplete or was stopped. This may be due to a third party software that uses a different password defined by ASUS. You have to unlock the SSD in the software before proceeding with Secure Erase.

3.9.3 ASUS User Profile

This item allows you to store or load multiple BIOS settings.

Load Profile

This item allows you to load the previous BIOS settings saved in the BIOS Flash. Key in the profile number that saved your BIOS settings, press <Enter>, and then select **Yes**.



- DO NOT shut down or reset the system while updating the BIOS to prevent the system boot failure!
- We recommend that you update the BIOS file only coming from the same memory/ CPU configuration and BIOS version.

Profile Name

This item allows you to key in a profile name.

Save to Profile

This item allows you to save the current BIOS settings to the BIOS Flash, and create a profile. Key in a profile number from one to eight, press <Enter>, and then select **Yes**.

Load/Save Profile from/to USB Drive

This item allows you to load or save profile from your USB drive, load and save profile to your USB drive.

3.9.4 ASUS SPD Information

This item allows you to view the DRAM SPD information.

3.9.5 ASUS Armoury Crate

This item allows you to enable or disable the ASUS Armoury Crate. The ASUS Armoury Crate is a fixed Advanced Configuration and Power Interface (ACPI) table that provides Windows with a platform binary that the operating system can execute.

3.9.6 Graphics Card Information

This item displays the information about the graphics card installed in your system.

GPU Post

This item displays the information and recommended configuration for the PCIe slots that the graphics card is installed in your system.



This feature is only supported on selected ASUS graphics cards.

Bus Interface

This item allows you to select the bus interface.

Configuration options: [PCIEX16_1] [PCIEX16_2] [PCIEX16_3]

3.10 Exit menu

The Exit menu items allow you to load the optimal default values for the BIOS items, and save or discard your changes to the BIOS items. You can access the EZ Mode from the Exit menu.

Load Optimized Defaults

This option allows you to load the default values for each of the parameters on the Setup menus. When you select this option or if you press <F5>, a confirmation window appears. Select **OK** to load the default values.

Save Changes & Reset

Once you are finished making your selections, choose this option from the Exit menu to ensure the values you selected are saved. When you select this option or if you press <F10>, a confirmation window appears. Select **OK** to save changes and exit.

Discard Changes and Exit

This option allows you to exit the Setup program without saving your changes. When you select this option or if you press <Esc>, a confirmation window appears. Select **Yes** to discard changes and exit.

Launch EFI Shell from USB drives

This item allows you to attempt to launch the EFI Shell application (shellx64.efi) from one of the available filesystem devices.

3.11 Updating BIOS

The ASUS website publishes the latest BIOS versions to provide enhancements on system stability, compatibility, and performance. However, BIOS updating is potentially risky. If there is no problem using the current version of BIOS, DO NOT manually update the BIOS. Inappropriate BIOS updating may result to system's failure to boot. Carefully follow the instructions in this chapter to update your BIOS when necessary.



Visit <http://www.asus.com> to download the latest BIOS file for this motherboard.

The following utilities allow you to manage and update the motherboard BIOS setup program.

1. EZ Update: Updates the BIOS in Windows® environment.
2. ASUS EZ Flash 3: Updates the BIOS using a USB flash drive.
3. ASUS CrashFree BIOS 3: Restores the BIOS using the motherboard support DVD or a USB flash drive when the BIOS file fails or gets corrupted.

3.11.1 EZ Update

The EZ Update is a utility that allows you to update the motherboard BIOS in Windows® environment.



-
- EZ Update requires an Internet connection either through a network or an ISP (Internet Service Provider).
 - This utility is available in the support DVD that comes with the motherboard package.
-

3.11.2 ASUS EZ Flash 3

ASUS EZ Flash 3 allows you to download and update to the latest BIOS through the Internet without having to use a bootable floppy disk or an OS-based utility.



Updating through the Internet varies per region and Internet conditions. Check your local Internet connection before updating through the Internet.

To update the BIOS by USB:

1. Insert the USB flash disk that contains the latest BIOS file to the USB port.
2. Enter the **Advanced** Mode of the BIOS setup program. Go to the **Tool** menu to select **ASUS EZ Flash 3 Utility** and press <Enter>.
3. Select **via Storage Device(s)**.

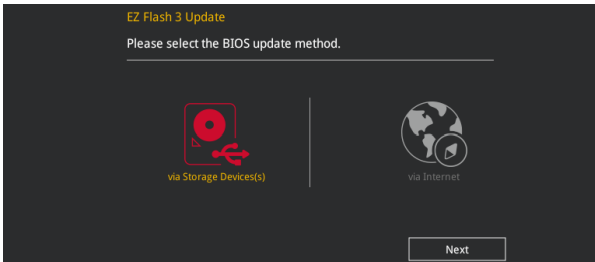

4. Press <Tab> to switch to the Drive field.
5. Press the Up/Down arrow keys to find the USB flash disk that contains the latest BIOS, and then press <Enter>.
6. Press <Tab> to switch to the Folder Info field.
7. Press the Up/Down arrow keys to find the BIOS file, and then press <Enter> to perform the BIOS update process. Reboot the system when the update process is done.

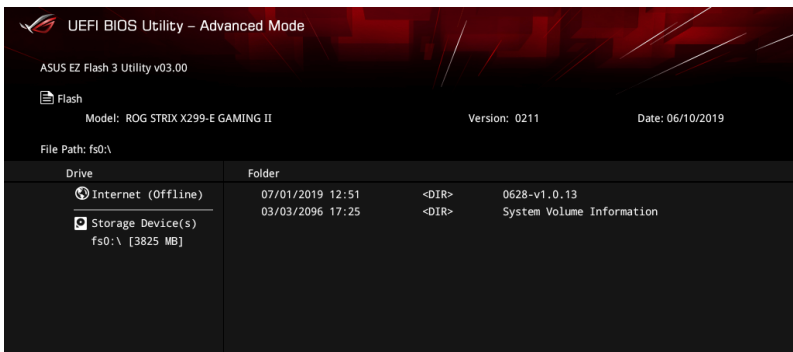



- This function can support devices such as a USB flash disk with FAT 32/16 format and single partition only.
- DO NOT shut down or reset the system while updating the BIOS to prevent system boot failure!



Ensure to load the BIOS default settings to ensure system compatibility and stability. Select the Load Optimized Defaults item under the Exit menu. See section **Exit Menu** for details.

To update the BIOS by Internet:

1. Enter the Advanced Mode of the BIOS setup program. Go to the Tool menu to select **ASUS EZ Flash 3 Utility** and press <Enter>.
2. Select **via Internet**.

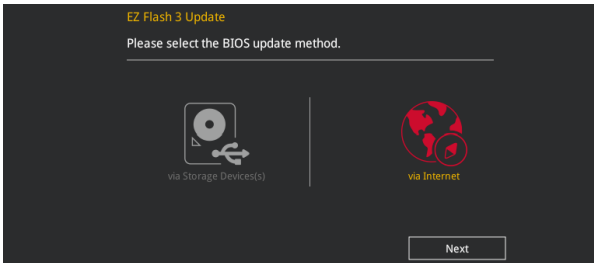

3. Press the Left/Right arrow keys to select an Internet connection method, and then click **Next**.

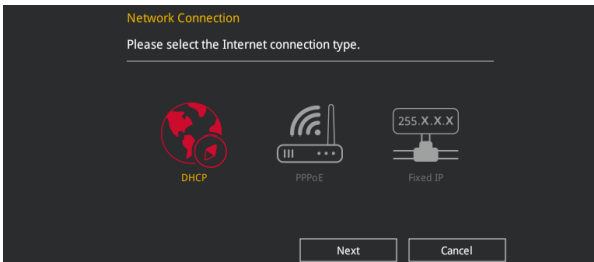

4. Follow the onscreen instructions to complete the update.
5. Reboot the system when the update process is done.



Ensure to load the BIOS default settings to ensure system compatibility and stability. Select the Load Optimized Defaults item under the Exit menu. See section **Exit Menu** for details.

3.11.3 ASUS CrashFree BIOS 3

The ASUS CrashFree BIOS 3 utility is an auto recovery tool that allows you to restore the BIOS file when it fails or gets corrupted during the updating process. You can restore a corrupted BIOS file using the motherboard support DVD or a USB flash drive that contains the BIOS file.



The BIOS file in the motherboard support DVD may be older than the BIOS file published on the ASUS official website. If you want to use the newer BIOS file, download the file at <https://www.asus.com/support/> and save it to a USB flash drive.

Recovering the BIOS

To recover the BIOS:

1. Turn on the system.
2. Insert the motherboard support DVD to the optical drive, or the USB flash drive containing the BIOS file to the USB port.
3. The utility automatically checks the devices for the BIOS file. When found, the utility reads the BIOS file and enters ASUS EZ Flash 3 automatically.
4. The system requires you to enter BIOS Setup to recover the BIOS setting. To ensure system compatibility and stability, we recommend that you press <F5> to load default BIOS values.



DO NOT shut down or reset the system while updating the BIOS! Doing so can cause system boot failure!

RAID Support

4

4.1 RAID configurations

The motherboard comes with the Intel® Rapid Storage Technology that supports RAID 0, RAID 1, RAID 5 and RAID 10 configuration.



For more information on configuring your RAID sets, please refer to the **RAID Configuration Guide** which you can find at <https://www.asus.com/support>.

4.1.1 RAID definitions

RAID 0 (Data striping) optimizes two identical hard disk drives to read and write data in parallel, interleaved stacks. Two hard disks perform the same work as a single drive but at a sustained data transfer rate, double that of a single disk alone, thus improving data access and storage. Use of two new identical hard disk drives is required for this setup.

RAID 1 (Data mirroring) copies and maintains an identical image of data from one drive to a second drive. If one drive fails, the disk array management software directs all applications to the surviving drive as it contains a complete copy of the data in the other drive. This RAID configuration provides data protection and increases fault tolerance to the entire system.

Use two new drives or use an existing drive and a new drive for this setup. The new drive must be of the same size or larger than the existing drive.

RAID 5 stripes both data and parity information across three or more hard disk drives. Among the advantages of RAID 5 configuration include better HDD performance, fault tolerance, and higher storage capacity. The RAID 5 configuration is best suited for transaction processing, relational database applications, enterprise resource planning, and other business systems. Use a minimum of three identical hard disk drives for this setup.

RAID 10 is data striping and data mirroring combined without parity (redundancy data) having to be calculated and written. With the RAID 10 configuration you get all the benefits of both RAID 0 and RAID 1 configurations. Use four new hard disk drives or use an existing drive and three new drives for this setup.

Appendix

Q-Code table

Code	Description
00	Not used
01	Power on. Reset type detection (soft/hard).
02	AP initialization before microcode loading
03	System Agent initialization before microcode loading
04	PCH initialization before microcode loading
06	Microcode loading
07	AP initialization after microcode loading
08	System Agent initialization after microcode loading
09	PCH initialization after microcode loading
0B	Cache initialization
0C – 0D	Reserved for future AMI SEC error codes
0E	Microcode not found
0F	Microcode not loaded
10	PEI Core is started
11 – 14	Pre-memory CPU initialization is started
15 – 18	Pre-memory System Agent initialization is started
19 – 1C	Pre-memory PCH initialization is started
2B – 2F	Memory initialization
30	Reserved for ASL (see ASL Status Codes section below)
31	Memory Installed
32 – 36	CPU post-memory initialization
37 – 3A	Post-Memory System Agent initialization is started
3B – 3E	Post-Memory PCH initialization is started
4F	DXE IPL is started
50 – 53	Memory initialization error. Invalid memory type or incompatible memory speed
54	Unspecified memory initialization error
55	Memory not installed
56	Invalid CPU type or Speed
57	CPU mismatch
58	CPU self test failed or possible CPU cache error
59	CPU micro-code is not found or micro-code update is failed
5A	Internal CPU error
5B	Reset PPI is not available
5C – 5F	Reserved for future AMI error codes

(continued on the next page)

Q-Code table

Code	Description
E0	S3 Resume is started (S3 Resume PPI is called by the DXE IPL)
E1	S3 Boot Script execution
E2	Video repost
E3	OS S3 wake vector call
E4 – E7	Reserved for future AMI progress codes
E8	S3 Resume Failed
E9	S3 Resume PPI not Found
EA	S3 Resume Boot Script Error
EB	S3 OS Wake Error
EC – EF	Reserved for future AMI error codes
F0	Recovery condition triggered by firmware (Auto recovery)
F1	Recovery condition triggered by user (Forced recovery)
F2	Recovery process started
F3	Recovery firmware image is found
F4	Recovery firmware image is loaded
F5 – F7	Reserved for future AMI progress codes
F8	Recovery PPI is not available
F9	Recovery capsule is not found
FA	Invalid recovery capsule
FB – FF	Reserved for future AMI error codes
60	DXE Core is started
61	NVRAM initialization
62	Installation of the PCH Runtime Services
63 – 67	CPU DXE initialization is started
68	PCI host bridge initialization
69	System Agent DXE initialization is started
6A	System Agent DXE SMM initialization is started
6B – 6F	System Agent DXE initialization (System Agent module specific)
70	PCH DXE initialization is started
71	PCH DXE SMM initialization is started
72	PCH devices initialization
73 – 77	PCH DXE Initialization (PCH module specific)
78	ACPI module initialization
79	CSM initialization
7A – 7F	Reserved for future AMI DXE codes

(continued on the next page)

Q-Code table

Code	Description
90	Boot Device Selection (BDS) phase is started
91	Driver connecting is started
92	PCI Bus initialization is started
93	PCI Bus Hot Plug Controller Initialization
94	PCI Bus Enumeration
95	PCI Bus Request Resources
96	PCI Bus Assign Resources
97	Console Output devices connect
98	Console input devices connect
99	Super IO Initialization
9A	USB initialization is started
9B	USB Reset
9C	USB Detect
9D	USB Enable
9E – 9F	Reserved for future AMI codes
A0	IDE initialization is started
A1	IDE Reset
A2	IDE Detect
A3	IDE Enable
A4	SCSI initialization is started
A5	SCSI Reset
A6	SCSI Detect
A7	SCSI Enable
A8	Setup Verifying Password
A9	Start of Setup
AA	Reserved for ASL (see ASL Status Codes section below)
AB	Setup Input Wait
AC	Reserved for ASL (see ASL Status Codes section below)
AD	Ready To Boot event
AE	Legacy Boot event
AF	Exit Boot Services event
B0	Runtime Set Virtual Address MAP Begin
B1	Runtime Set Virtual Address MAP End
B2	Legacy Option ROM Initialization
B3	System Reset

(continued on the next page)

Q-Code table

Code	Description
B4	USB hot plug
B5	PCI bus hot plug
B6	Clean-up of NVRAM
B7	Configuration Reset (reset of NVRAM settings)
B8– BF	Reserved for future AMI codes
D0	CPU initialization error
D1	System Agent initialization error
D2	PCH initialization error
D3	Some of the Architectural Protocols are not available
D4	PCI resource allocation error. Out of Resources
D5	No Space for Legacy Option ROM
D6	No Console Output Devices are found
D7	No Console Input Devices are found
D8	Invalid password
D9	Error loading Boot Option (LoadImage returned error)
DA	Boot Option is failed (StartImage returned error)
DB	Flash update is failed
DC	Reset protocol is not available

ACPI/ASL Checkpoints (under OS)

Code	Description
03	System is entering S3 sleep state
04	System is entering S4 sleep state
05	System is entering S5 sleep state
30	System is waking up from the S3 sleep state
40	System is waking up from the S4 sleep state
AC	System has transitioned into ACPI mode. Interrupt controller is in PIC mode.
AA	System has transitioned into ACPI mode. Interrupt controller is in APIC mode.

Notices

FCC Compliance Information

Responsible Party: Asus Computer International

Address: 48720 Kato Rd., Fremont, CA 94538, USA

Phone / Fax No: (510)739-3777 / (510)608-4555

Identification of the assembled product: INTEL® WI-FI 6 AX200

Identification of the modular components used in the assembly:

Model Name: INTEL® WI-FI 6 AX200 FCC ID: PD9AX200NG

This device complies with part 15 of the FCC Rules. Operation is subject to the following two conditions: (1) This device may not cause harmful interference, and (2) this device must accept any interference received, including interference that may cause undesired operation.

This equipment has been tested and found to comply with the limits for a Class B digital device, pursuant to part 15 of the FCC Rules. These limits are designed to provide reasonable protection against harmful interference in a residential installation. This equipment generates, uses and can radiate radio frequency energy and, if not installed and used in accordance with the instructions, may cause harmful interference to radio communications. However, there is no guarantee that interference will not occur in a particular installation. If this equipment does cause harmful interference to radio or television reception, which can be determined by turning the equipment off and on, the user is encouraged to try to correct the interference by one or more of the following measures:

- Reorient or relocate the receiving antenna.
- Increase the separation between the equipment and receiver.
- Connect the equipment into an outlet on a circuit different from that to which the receiver is connected.
- Consult the dealer or an experienced radio/TV technician for help.

RF exposure warning

This equipment must be installed and operated in accordance with provided instructions and the antenna(s) used for this transmitter must be installed to provide a separation distance of at least 20 cm from all persons and must not be co-located or operating in conjunction with any other antenna or transmitter. End-users and installers must be provide with antenna installation instructions and transmitter operating conditions for satisfying RF exposure compliance.

Compliance Statement of Innovation, Science and Economic Development Canada (ISED)

This device complies with Innovation, Science and Economic Development Canada licence exempt RSS standard(s). Operation is subject to the following two conditions: (1) this device may not cause interference, and (2) this device must accept any interference, including interference that may cause undesired operation of the device.

Operation in the band 5150–5250 MHz is only for indoor use to reduce the potential for harmful interference to co-channel mobile satellite systems.

CAN ICES-3(B)/NMB-3(B)

Déclaration de conformité de Innovation, Sciences et Développement économique Canada (ISED)

Le présent appareil est conforme aux CNR d'Innovation, Sciences et Développement économique Canada applicables aux appareils radio exempts de licence. L'exploitation est autorisée aux deux conditions suivantes : (1) l'appareil ne doit pas produire de brouillage, et (2) l'utilisateur de l'appareil doit accepter tout brouillage radioélectrique subi, même si le brouillage est susceptible d'en compromettre le fonctionnement.

La bande 5150–5250 MHz est réservée uniquement pour une utilisation à l'intérieur afin de réduire les risques de brouillage préjudiciable aux systèmes de satellites mobiles utilisant les mêmes canaux.

CAN ICES-3(B)/NMB-3(B)

VCCI: Japan Compliance Statement

Class B ITE

この装置は、クラスB情報技術装置です。この装置は、家庭環境で使用することを目的としていますが、この装置がラジオやテレビジョン受信機に近接して使用されると、受信障害を引き起こすことがあります。

取扱説明書に従って正しい取り扱いをして下さい。

VCCI-B

KC: Korea Warning Statement

B급 기기 (가정용 방송통신기자재)

이 기기는 가정용(B급) 전자파적합기기로서 주로 가정에서 사용하는 것을 목적으로 하며, 모든 지역에서 사용할 수 있습니다.

*당해 무선설비는 전파혼신 가능성이 있으므로 인명안전과 관련된 서비스는 할 수 없습니다.

Google™ License Terms

Copyright© 2019 Google Inc. All Rights Reserved.

Licensed under the Apache License, Version 2.0 (the “License”); you may not use this file except in compliance with the License. You may obtain a copy of the License at:

<http://www.apache.org/licenses/LICENSE-2.0>

Unless required by applicable law or agreed to in writing, software distributed under the License is distributed on an “AS IS” BASIS, WITHOUT WARRANTIES OR CONDITIONS OF ANY KIND, either express or implied.

See the License for the specific language governing permissions and limitations under the License.

NCC: Taiwan Wireless Statement

經型式認證合格之低功率射頻電機，非經許可，公司、商號或使用者均不得擅自變更頻率、加大功率或變更原設計之特性及功能。低功率射頻電機之使用不得影響飛航安全及干擾合法通信；經發現有干擾現象時，應立即停用，並改善至無干擾時方得繼續使用。前項合法通信，指依電信法規定作業之無線電通信。低功率射頻電機須忍受合法通信或工業、科學及醫療用電波輻射性電機設備之干擾。

應避免影響附近雷達系統之操作。

Japan RF Equipment Statement

屋外での使用について

本製品は、5GHz帯域での通信に対応しています。電波法の定めにより5.2GHz、5.3GHz帯域の電波は屋外で使用が禁じられています。

法律および規制遵守

本製品は電波法及びこれに基づく命令の定めるところに従い使用してください。日本国外では、その国の法律または規制により、本製品の使用ができないことがあります。このような国では、本製品を運用した結果、罰せられることがあります。当社は一切責任を負いかねますのでご了承ください。

Précautions d'emploi de l'appareil :

- Soyez particulièrement vigilant quant à votre sécurité lors de l'utilisation de cet appareil dans certains lieux (les avions, les aéroports, les hôpitaux, les stations-service et les garages professionnels).
- Évitez d'utiliser cet appareil à proximité de dispositifs médicaux implantés. Si vous portez un implant électronique (stimulateurs cardiaques, pompes à insuline, neurostimulateurs...), veuillez impérativement respecter une distance minimale de 15 centimètres entre cet appareil et l'implant pour réduire les risques d'interférence.
- Utilisez cet appareil dans de bonnes conditions de réception pour minimiser le niveau de rayonnement. Ce n'est pas toujours le cas dans certaines zones ou situations, notamment dans les parkings souterrains, dans les ascenseurs, en train ou en voiture ou tout simplement dans un secteur mal couvert par le réseau.
- Tenez cet appareil à distance du ventre des femmes enceintes et du bas-ventre des adolescents.

Declaration of compliance for product environmental regulation

ASUS follows the green design concept to design and manufacture our products, and makes sure that each stage of the product life cycle of ASUS product is in line with global environmental regulations. In addition, ASUS disclose the relevant information based on regulation requirements.

Please refer to <http://csr.asus.com/Compliance.htm> for information disclosure based on regulation requirements ASUS is complied with:

EU REACH and Article 33

Complying with the REACH (Registration, Evaluation, Authorisation, and Restriction of Chemicals) regulatory framework, we published the chemical substances in our products at ASUS REACH website at <http://csr.asus.com/english/REACH.htm>.

EU RoHS

This product complies with the EU RoHS Directive. For more details, see <http://csr.asus.com/english/article.aspx?id=35>

India RoHS

This product complies with the "India E-Waste (Management) Rules, 2016" and prohibits use of lead, mercury, hexavalent chromium, polybrominated biphenyls (PBBs) and polybrominated diphenyl ethers (PBDEs) in concentrations exceeding 0.1% by weight in homogenous materials and 0.01% by weight in homogenous materials for cadmium, except for the exemptions listed in Schedule II of the Rule.

Vietnam RoHS

ASUS products sold in Vietnam, on or after September 23, 2011, meet the requirements of the Vietnam Circular 30/2011/TT-BCT.

Các sản phẩm ASUS bán tại Việt Nam, vào ngày 23 tháng 9 năm 2011 trở về sau, đều phải đáp ứng các yêu cầu của Thông tư 30/2011/TT-BCT của Việt Nam.

Turkey RoHS

AEEE Yönetmeliğine Uygundur

ASUS Recycling/Takeback Services

ASUS recycling and takeback programs come from our commitment to the highest standards for protecting our environment. We believe in providing solutions for you to be able to responsibly recycle our products, batteries, other components as well as the packaging materials. Please go to <http://csr.asus.com/english/Takeback.htm> for detailed recycling information in different regions.



DO NOT throw the motherboard in municipal waste. This product has been designed to enable proper reuse of parts and recycling. This symbol of the crossed out wheeled bin indicates that the product (electrical and electronic equipment) should not be placed in municipal waste. Check local regulations for disposal of electronic products.



DO NOT throw the mercury-containing button cell battery in municipal waste. This symbol of the crossed out wheeled bin indicates that the battery should not be placed in municipal waste.

Regional notice for California



WARNING

Cancer and Reproductive Harm -
www.P65Warnings.ca.gov

Simplified EU Declaration of Conformity

ASUSTek Computer Inc. hereby declares that this device is in compliance with the essential requirements and other relevant provisions of Directive 2014/53/EU. Full text of EU declaration of conformity is available at <https://www.asus.com/support/>

The WiFi operating in the band 5150-5350MHz shall be restricted to indoor use for countries listed in the table below:

Declaration simplifiée de conformité de l'UE

ASUSTek Computer Inc. déclare par la présente que cet appareil est conforme aux critères essentiels et autres clauses pertinentes de la directive 2014/53/EU. La déclaration de conformité de l'UE peut être téléchargée à partir du site internet suivant : <https://www.asus.com/support/>

Dans la plage de fréquence 5150-5350 MHz, le Wi-Fi est restreint à une utilisation en intérieur dans les pays listés dans le tableau ci-dessous:

Vereinfachte EU-Konformitätserklärung

ASUSTek COMPUTER INC erklärt hiermit, dass dieses Gerät mit den grundlegenden Anforderungen und anderen relevanten Bestimmungen der Richtlinie 2014/53/EU übereinstimmt. Der gesamte Text der EU-Konformitätserklärung ist verfügbar unter: <https://www.asus.com/support/>

Der WLAN-Betrieb im Band von 5150-5350 MHz ist für die in der untenen Tabelle aufgeführten Länder auf den Innenbereich beschränkt:

Dichiarazione di conformità UE semplificata

ASUSTek Computer Inc. con la presente dichiara che questo dispositivo è conforme ai requisiti essenziali e alle altre disposizioni pertinenti con la direttiva 2014/53/EU. Il testo completo della dichiarazione di conformità UE è disponibile all'indirizzo: <https://www.asus.com/support/>

L'utilizzo della rete Wi-Fi con frequenza compresa nell'intervallo 5150-5350MHz deve essere limitato all'interno degli edifici per i paesi presenti nella seguente tabella:

Упрощенное заявление о соответствии европейской директиве

ASUSTek Computer Inc. заявляет, что устройство соответствует основным требованиям и другим соответствующим условиям директивы 2014/53/EU. Полный текст декларации соответствия ЕС доступен на <https://www.asus.com/support/>

Работа WiFi в диапазоне частот 5150-5350 должна быть ограничена использованием в помещениях для стран, перечисленных в таблице ниже:
إعلان التوافق المبسط الصادر عن الاتحاد الأوروبي

تقر شركة ASUSTek Computer Inc أن هذا الجهاز يتوافق مع المتطلبات الأساسية والأحكام الأخرى ذات الصلة الخاصة بوجوبه 2014/53/EE. يتوفر النص الكامل لإعلان التوافق الصادر عن الاتحاد الأوروبي على: <https://www.asus.com/support/>

يجب حصر استخدام WiFi المعلنه بـ 5150-5350 ميجاز هرتز على الاستخدام الداخلي للبلدان المدرجة بالجدول.

Опрощена декларация за съответствие на ЕС

С насочено ASUSTek Computer Inc. декларира, че това устройство е в съответствие със съществуващите изисквания и другите приложими постановления на свързаната Директива 2014/53/EE. Пълният текст на ЕС декларация за съвместимост е достъпен на адрес <https://www.asus.com/support/>

WiFi, работеща в диапазон 5150-5350MHz, трябва да се ограничи до употреба на закрито за страните, посочени в таблицата по-долу:

Declaração de Conformidade UE Simplificada

ASUSTek Computer Inc. declara que este dispositivo está em conformidade com os requisitos essenciais e outras disposições relevantes relacionadas às diretivas 2014/53/EU. O texto completo da declaração de conformidade CE está disponível em <https://www.asus.com/support/>

O WiFi operando na banda 5150-5350MHz deve ser restrito para uso interno para os países listados na tabela abaixo:

Поједностављена ЕУ изјава о ускладности

ASUSTek Computer Inc. овим изјављује да је овај уређај ускладан с битним захтевима и осталим одговарајућим одредбама директиве 2014/53/ЕУ. Цјели текст ЕУ изјаве о ускладности доступан је на <https://www.asus.com/support/>

WiFi који ради на опсегу фреквенција 5150-5350 MHz бит ће ограничен на употребу у затвореном простору у земљама на доњем списку:

Zjednodušené prohlášení o shodě EU

Společnost ASUSTek Computer Inc. tímto prohlašuje, že toto zařízení splňuje základní požadavky a další příslušná ustanovení směrnice 2014/53/EU. Plné znění prohlášení o shodě EU je k dispozici na adrese <https://www.asus.com/support/>

V zemích uvedených v tabulce je provoz sítě Wi-Fi ve frekvenčním rozsahu 5 150 - 5 350 MHz povolen pouze ve vnitřních prostorech:

Forenket EU-overensstemmelseserklæring

ASUSTek Computer Inc. erklærer hermed at denne enhed er i overensstemmelse med hovedkravene og øvrige relevante bestemmelser i direktivet 2014/53/EU. Hele EU-overensstemmelseserklæringen kan findes på <https://www.asus.com/support/>

Wi-Fi, der bruger 5150-5350 MHz skal begrænses til indendørs brug i lande, der er anført i tabellen:

Vereenvoudigd EU-conformiteitsverklaring

ASUSTek Computer Inc. verklaart hierbij dat dit apparaat voldoet aan de essentiële vereisten en andere relevante bepalingen van Richtlijn 2014/53/EU. De volledige tekst van de EU-conformiteitsverklaring is beschikbaar op <https://www.asus.com/support/>

De WiFi op 5150-5350MHz zal beperkt zijn tot binnengebruik voor in de tabel vermelde landen:

Lihtsustatud EU vastavusdeklaratsioon

Käesolevaga kinnitab ASUSTek Computer Inc, et seade vastab direktiivi 2014/53/EU olulistele nõuetele ja teistele asjakohastele sätetele. EL vastavusdeklaratsiooni täistekst on teinud available veebisaidil <https://www.asus.com/support/>

Sagedusvahemikus 5150-5350 MHz töötava WiFi kasutamine on järgmistes riikides lubatud ainult siseruumides:

Eurooppa - EY'n vaatimustenmukaisuusvakuutus

ASUSTek Computer Inc. ilmoittaa täten, että tämä laite on direktiivin 2014/53/EU olennaisien vaatimusten ja muiden asiaankuuluvien lisäysten mukainen. Koko EY:n vaatimustenmukaisuusvakuutuksen teksti on luettavissa osoitteessa <https://www.asus.com/support/>

5 150 - 5 350 MHz:n taajuudella toimiva WiFi on rajoitettu sisäkäyttöön taulukossa luetteluissa maissa:

تبعیت از نسخه سده شده بیاتیه انتخابیه اروپا

ASUSTek Computer Inc. در اینجا اعلام می کند که این دستگاه با نیازهای اساسی و سایر مقررات مربوط به بیاتیه 2014/53/EE مطابقت دارد. متن کامل پیروی از این بیاتیه انتخابیه اروپا در این آدرس موجود است: <https://www.asus.com/support/>

عذردهنده 5150-5350 مگاهرتز برای استفاده در فضای داخل ساختمان برای کشورها فهرست شده در جدول، محدود شود.

Απολογομένη Δήλωση Συμμόρφωσης ΕΕ

Διά του παρόντος η ASUSTek Computer Inc. δηλώνει ότι αυτή η συσκευή είναι συμμόρφη με τις βασικές προϋποθέσεις και άλλες σχετικές διατάξεις της Οδηγίας 2014/53/ΕΕ. Το πλήρες κείμενο της δήλωσης συμμόρφωσης της ΕΕ είναι διαθέσιμο στη διεύθυνση <https://www.asus.com/support/>

To WiFi που λειτουργεί στη ζώνη 5150-5350MHz περιορίζεται για χρήση σε εσωτερικούς χώρους για τις χώρες που αναφέρονται στον παρακάτω πίνακα:

הגדרת האימות הרגולטורית מקובלת עבור האיחוד האירופי

ASUSTek Computer Inc. מצהירה באופן פומבי כי מכשיר זה תואם לדרישות החוקיות ולשאר המסמכים הרגולטוריים של תקנה 2014/53/EE. ניתן לקרוא את הסוג המלא של הגדרת האימות הרגולטורית עבור האיחוד האירופי בכתובת: <https://www.asus.com/support/>

יש להגביל רשתות Wi-Fi הפועלות ברצועות התדרים 5150-5350MHz לשימוש בתוך מבנים מסוימים בארצות המפורטות ברשימה הבאה:

Egyszerűsített EU megfeleléségi nyilatkozat

Az ASUSTek Computer Inc. ezennel kijelenti, hogy ez az eszköz megfelel az 2014/53/EU sz. irányelv alapvető követelményeinek és egyéb vonatkozó rendelkezéseinek. Az EU megfeleléségi nyilatkozat teljes szövegét a következő weboldalon tekintheti meg: <https://www.asus.com/support/>

Az 5150-5350 MHz-es sávban működő Wi-Fi-t beltéri használatra kell korlátozni az alábbi táblázatban felsorolt országokban:

Pernyataan Kesesuaian UE yang Disederhanakan

ASUSTek Computer Inc. dengan ini menyatakan bahwa perangkat ini memenuhi persyaratan utama dan ketentuan relevan lainnya yang terdapat pada Peraturan 2014/53/EU. Teks lengkap pernyataan kesesuaian UE tersedia di: <https://www.asus.com/support/>

WiFi yang Beroperasi pada 5150-5350 MHz akan terbatas untuk penggunaan dalam ruangan di negara yang tercantum dalam tabel

Vienākārsta ES atbilstības paziņojums

ASUSTek Computer Inc. ar šo paziņo, ka šī ierīce atbilst Direktīvas 2014/53/ES būtiskajām prasībām un citiem citiem saistītajiem nosacījumiem. Pilns ES atbilstības paziņojuma teksts pieejams šeit: <https://www.asus.com/support/>

Wi-Fi darbība 5150-5350 MHz ir jāierobežo lietošanai telpās valstīs, kuras norādītas tālāk.

Supaprastinta ES atitikties deklaracija

Šiame dokumente bendrovė „ASUSTek Computer Inc.“ pareiškia, kad šis prietaisas atitinka pagrindinius reikalavimus ir kitas susijusias Direktyvos 2014/53/ES nuostatas. Visas ES atitikties deklaracijos tekstas pateikiamas čia: <https://www.asus.com/support/>

Toliau nurodytose šalyse „WiFi“ ryšiu, veikiančiu 5 150–5 350 MHz dažniu juostoje, galima naudotis tik patalpose:

Ovaj uredaj može da se koristi u državama navedenim iznad:

Förenklad EU-samsvarserklæring

ASUSTek Computer Inc. erklærer herved at denne enheten er i samsvar med hovedsaklige krav og andre relevante forskrifter i direktivet 2014/53/EU. Fullstendig tekst for EU-samsvarserklæring finnes på: <https://www.asus.com/support/>

Wi-Fi-området 5150–5350 MHz skal begrenses til innendørs bruk for landene som er oppført i tabellen:

Uproszczone deklaracja zgodności UE

Firma ASUSTek Computer Inc. niniejszym oświadcza, że urządzenie to jest zgodne z zasadniczymi wymogami i innymi właściwymi postanowieniami dyrektywy 2014/53/EU. Pełny tekst deklaracji zgodności UE jest dostępny pod adresem <https://www.asus.com/support/>

W krajach wymienionych w tabeli działanie sieci Wi-Fi w paśmie 5150–5350 MHz powinno być ograniczone wyłącznie do pomieszczeń:

Declaração de Conformidade Simplificada da UE

A ASUSTek Computer Inc. declara que este dispositivo está em conformidade com os requisitos essenciais e outras disposições relevantes da Diretiva 2014/53/UE. O texto integral da declaração de conformidade da UE está disponível em <https://www.asus.com/support/>

A utilização das frequências WiFi de 5150 a 5350MHz está restrita a ambientes interiores nos países apresentados na tabela:

Declaratie de conformitate UE, versiune simplificata

Prin prezenta, ASUSTek Computer Inc. declară că acest dispozitiv este în conformitate cu reglementările esențiale și cu celelalte prevederi relevante ale Directivei 2014/53/UE. Textul complet al declarației de conformitate UE este disponibil la adresa <https://www.asus.com/support/>

Pentru țările listate în tabelul de mai jos, rețelele WiFi care funcționează în banda de frecvență de 5.150-5.350 MHz trebuie utilizate doar în interior:

Pojednostavljena Deklaracija o usaglašenosti EU

ASUSTek Computer Inc. ovim izjavljuje da je ovaj uređaj usaglašen sa osnovnim zahtevima i drugim relevantnim odredbama Direktive 2014/53/EU. Ceo tekst Deklaracije o usaglašenosti EU dostupan je na lokaciji <https://www.asus.com/support/>

WiFi koji radi u frekventnom opsegu od 5150 MHz do 5350 MHz ograničen je isključivo na upotrebu u zatvorenom prostoru za zemlje navedene u tabeli ispod:

Zjednodušené vyhlásenie o zhode platné pre EÚ

Spoločnosť ASUSTek Computer Inc. týmto vyhlasuje, že toto zariadenie je v súlade so základnými požiadavkami a ďalšími príslušnými ustanoveniami smernice č. 2014/53/EÚ. Plné znenie vyhlásenia o zhode pre EÚ je k dispozícii na lokalite <https://www.asus.com/support/>

Činnosť WiFi v pásme 5150 - 5350 MHz bude obmedzená na použitie vo vnútornom prostredí pre krajiny uvedené v tabuľke nižšie:

Poenostavljena izjava EU o skladnosti

ASUSTek Computer Inc. tukaj izjavlja, da je ta naprava skladna s temeljnimi zahtevami in drugimi relevantnimi določili Direktive 2014/53/EU. Polno besedilo izjave EU o skladnosti je na voljo na <https://www.asus.com/support/>

WiFi, ki deluje v pasovnem območju 5150–5350 MHz, mora biti v državah, navedenih v spodnjem seznamu, omejen na notranjo uporabo:

Declaración de conformidad simplificada para la UE

Por la presente, ASUSTek Computer Inc. declara que este dispositivo cumple los requisitos básicos y otras disposiciones pertinentes de la directiva 2014/53/UE. En <https://www.asus.com/support/> está disponible el texto completo de la declaración de conformidad para la UE.

La conexión WiFi con una frecuencia de funcionamiento de 5150-5350 MHz se restringirá al uso en interiores para los países enumerados en la tabla:

Förenklad EU-försäkran om överensstämmelse

ASUSTek Computer Inc. deklarerar härmed att denna enhet överensstämmer med de grundläggande kraven och andra relevanta bestämmelser i direktiv 2014/53/EU. Fullständig text av EU-försäkran om överensstämmelse finns på <https://www.asus.com/support/>

WiFi som används 5150-5350 MHz kommer att begränsas för användning inomhus i de länder som anges i tabellen:

ประกาศเกี่ยวกับความสอดคล้องของสหภาพยุโรปแบบย่อ

ASUSTek Computer Inc.

ขอประกาศในที่นี้ว่าอุปกรณ์นี้มีความสอดคล้องกับตามข้อกำหนดที่เป็นและเงื่อนไขที่เกี่ยวข้องอื่น ๆ ของบทมีอยู่คือกำหนด 2014/53/UE เนื้อหาที่สมบูรณ์ของประกาศความสอดคล้องกับ EU มีอยู่ที่ <https://www.asus.com/support/>

การดำเนินงานของ WiFi ที่ 5150-5350MHz ถูกจำกัดให้ใช้ในเวลาสำหรับประเทศที่แสดงในตาราง

Basitleştirilmiş AB Uyumluluk Bildirimi

ASUSTek Computer Inc., bu aygıtın 2014/53/UE Yönergesinin temel gereksinimlerine ve diğer ilgili hükümlerine uygun olduğunu bildirir. AB uyumluluk bildirimini tam metni şu adreste bulunabilir: <https://www.asus.com/support/>

5150-5350 MHz aralındaki WiFi çalışması, tabloda listelenen ülkeler için iç mekân kullanımıyla kısıtlanacaktır.

Спрощена декларація про відповідність нормам ЕС

ASUSTek Computer Inc. заявляє, що цей пристрій відповідає основним вимогам та іншим відповідним вимогам Директиви 2014 / 53 / EU. Повний текст декларації відповідності нормам ЕС доступний на <https://www.asus.com/support/>

Робота Wi-Fi на частоті 5150-5350 МГц обмежується використанням у приміщенні для країн, поданих у таблиці нижче:



AT	BE	BG	CZ	DK	EE	FR
DE	IS	IE	IT	EL	ES	CY
LV	LI	LT	LU	HU	MT	NL
NO	PL	PT	RO	SI	SK	TR
FI	SE	CH	UK	HR		

INTEL® Wi-Fi 6 AX200 output power table:

Function	Frequency	Maximum Output Power (EIRP)
WiFi	2412 - 2472 MHz	18.04 dBm
	5150 - 5350 MHz	18.23 dBm
	5470 - 5725 MHz	18.02 dBm
	5725 - 5850 MHz	8.76 dBm
Bluetooth	2402 - 2480 MHz	11.82 dBm

For the standard EN 300 440 V2.1.1, if this device operates in 5725-5875 MHz, it will be considered as a receiver category 2.

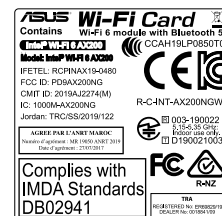

ASUS contact information

ASUSTeK COMPUTER INC.

Address 4F, No. 150, Li-Te Road, Peitou, Taipei 112, Taiwan
Telephone +886-2-2894-3447
Fax +886-2-2890-7798
Web site www.asus.com

Technical Support

Telephone +86-21-38429911
Fax +86-21-5866-8722, ext. 9101#
Online support <http://qr.asus.com/techserv>

ASUS COMPUTER INTERNATIONAL (America)

Address 48720 Kato Rd., Fremont, CA 94538, USA
Telephone +1-510-739-3777
Fax +1-510-608-4555
Web site <http://www.asus.com/us/>

Technical Support

Support fax +1-812-284-0883
Telephone +1-812-282-2787
Online support <http://qr.asus.com/techserv>

ASUS COMPUTER GmbH (Germany and Austria)

Address Harkort Str. 21-23, 40880 Ratingen, Germany
Fax +49-2102-959931
Web site <http://www.asus.com/de>
Online contact <http://eu-rma.asus.com/sales>

Technical Support

Telephone +49-2102-5789555
Support Fax +49-2102-959911
Online support <http://qr.asus.com/techserv>