

PRO-FORM®

HIT L6

proform.com

Model No. PFEL07920.0

Serial No. _____

Write the serial number in the space above for reference.

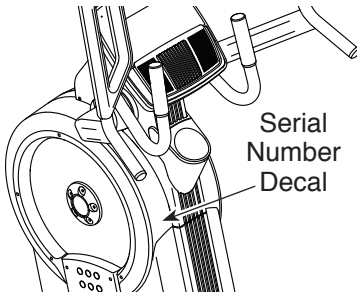

ACTIVATE YOUR WARRANTY

To register your product and activate your warranty today, go to my.proform.com.

CUSTOMER CARE

For service at any time, go to support.proform.com.

Or call 1-866-362-4490
Mon.–Fri. 6 a.m.–6 p.m. MT
Sat. 8 a.m.–12 p.m. MT

Please do not contact the store.

⚠ CAUTION

Read all precautions and instructions in this manual before using this equipment. Keep this manual for future reference.

USER'S MANUAL

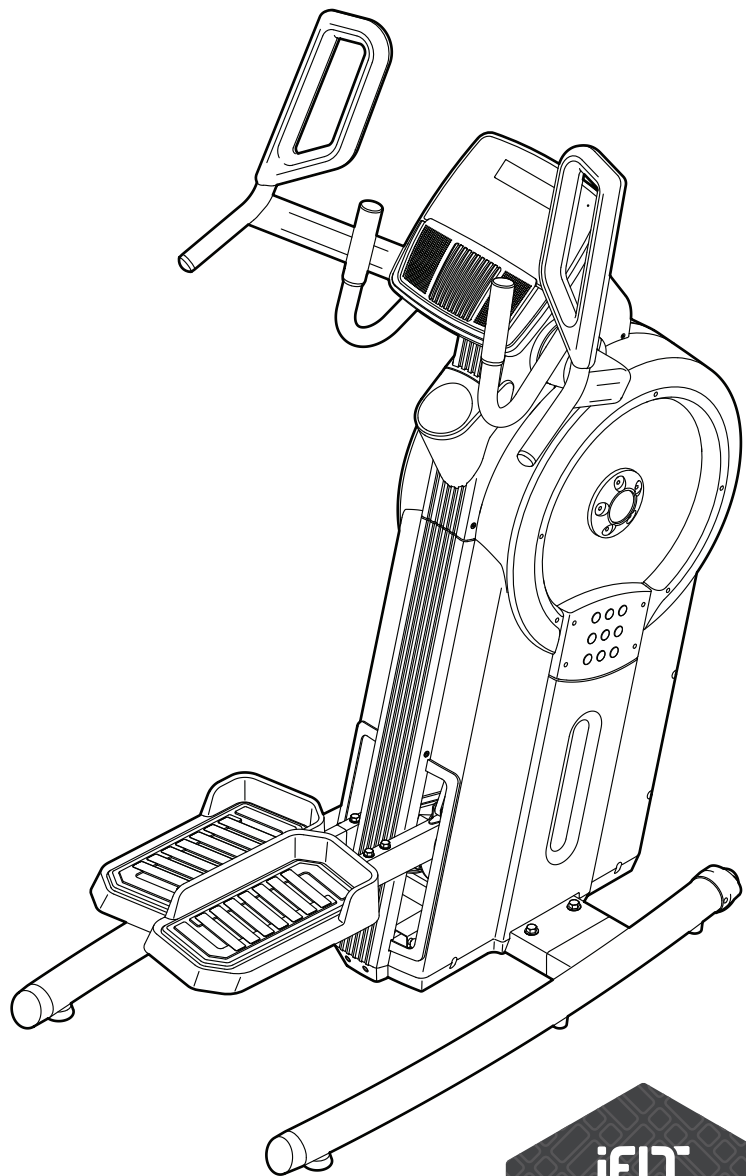

TABLE OF CONTENTS

WARNING DECAL PLACEMENT 2

IMPORTANT PRECAUTIONS..... 3

BEFORE YOU BEGIN..... 5

PART IDENTIFICATION CHART..... 6

ASSEMBLY..... 7

HOW TO USE THE TRAINER..... 13

HOW TO USE THE CONSOLE..... 15

MAINTENANCE AND TROUBLESHOOTING 21

FCC INFORMATION 22

EXERCISE GUIDELINES 23

PART LIST..... 24

EXPLODED DRAWING..... 26

ORDERING REPLACEMENT PARTS Back Cover

LIMITED WARRANTY..... Back Cover

WARNING DECAL PLACEMENT

This drawing shows the location(s) of the warning decal(s). **If a decal is missing or illegible, see the front cover of this manual and request a free replacement decal. Apply the decal in the location shown.** Note: The decal(s) may not be shown at actual size.

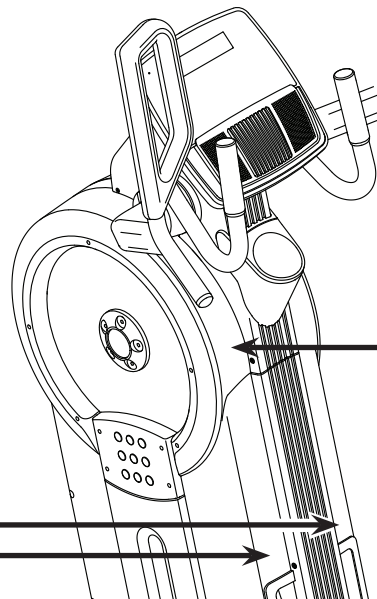

WARNING

- Misuse of this machine may result in serious injury.
- Read user's manual prior to use and follow all warnings and instructions.
- Do not allow children on or around machine.
- Pedals continue to spin when you stop pedaling.
- Spinning pedals can cause injury.
- Reduce pedal speed in a controlled manner.
- User weight must not exceed 325 lbs / 147 kgs.
- This product should always be used on a level surface.
- This product is not intended for therapeutic use.
- Replace label if damaged, illegible, or removed.

PROFORM and IFIT are registered trademarks of ICON Health & Fitness, Inc. The Bluetooth® word mark and logos are registered trademarks of Bluetooth SIG, Inc. and are used under license. Google Maps is a trademark of Google LLC. Wi-Fi is a registered trademark of Wi-Fi Alliance. WPA and WPA2 are trademarks of Wi-Fi Alliance.

IMPORTANT PRECAUTIONS

⚠ WARNING: To reduce the risk of serious injury, read all important precautions and instructions in this manual and all warnings on the trainer before using the trainer. ICON assumes no responsibility for personal injury or property damage sustained by or through the use of this product.

1. It is the responsibility of the owner to ensure that all users of the trainer are adequately informed of all precautions.
2. Before beginning any exercise program, consult your physician. This is especially important for persons over age 35 or persons with pre-existing health problems.
3. The trainer is not intended for use by persons with reduced physical, sensory, or mental capabilities or lack of experience and knowledge, unless they are given supervision or instruction about use of the trainer by someone responsible for their safety.
4. Use the trainer only as described in this manual.
5. The trainer is intended for home use only. Do not use the trainer in a commercial, rental, or institutional setting.
6. Keep the trainer indoors, away from moisture and dust. Do not put the trainer in a garage or covered patio, or near water.
7. Place the trainer on a level surface, with at least 3 ft. (0.9 m) of clearance in the front and rear of the trainer and 2 ft. (0.6 m) on each side. To protect the floor or carpet from damage, place a mat under the trainer.
8. Inspect and properly tighten all parts each time the trainer is used. Replace any worn parts immediately.
9. Keep children under age 16 and pets away from the trainer at all times.
10. The trainer should not be used by persons weighing more than 325 lbs. (147 kg).
11. Wear appropriate clothes while exercising; do not wear loose clothes that could become caught on the trainer. Always wear athletic shoes for foot protection while exercising.
12. Hold the handlebars or the grips when mounting, dismounting, or using the trainer. Before mounting or dismounting, bring the pedals to a stop with the pedal on the mounting or dismounting side in its lowest position.
13. The trainer does not have a freewheel; the pedals will continue to move until the flywheel stops. Reduce your pedaling speed in a controlled way.
14. Keep your back straight while using the trainer; do not arch your back.
15. Over exercising may result in serious injury or death. If you feel faint, if you become short of breath, or if you experience pain while exercising, stop immediately and cool down.

PROTECT

YOUR FITNESS EQUIPMENT
WITH AN EXTENDED SERVICE PLAN



Your new fitness equipment is not an ordinary purchase; it is an investment in your health and well being for years to come.

As the leading provider of manufacturer's extended service plans, ICON strives to protect your equipment and your future.

Please review the following service plans and find one that best fits your needs.

PREVENTIVE MAINTENANCE SERVICE PLANS

Equipment Price	3-Year Plan	5-Year Plan
\$0.00 to \$1000.00	\$199.99	\$289.99
\$1001.00 to \$1500.00	\$259.99	\$379.99
\$1501.00 to \$2500.00	\$339.99	\$489.99
(Bikes/Systems Only) \$0.00 to \$2500.00	\$139.99	NA

Features:

- Includes an annual preventive maintenance and performance check at your convenience
- Unlimited in-home repairs; no shipping required
- Covers parts and labor on all manufacturer's defects, as well as wear and tear on parts
- Up to 5 years of coverage available

STANDARD SERVICE PLANS

Equipment Price	1-Year Plan	2-Year Plan	3-Year Plan
\$0.00 to \$300.00	\$29.99	\$39.99	\$59.99
\$301.00 to \$1000.00	\$89.99	\$119.99	\$149.99
\$1001.00 to \$2000.00	\$109.99	\$139.99	\$179.99
\$2001.00 to \$3000.00	\$179.99	\$209.99	\$239.99

Features:

- Unlimited in-home repairs; no shipping required
- Covers parts and labor on all manufacturer's defects, as well as wear and tear on parts
- Up to 3 years of coverage available

To protect your fitness equipment today, please
call Customer Care at **1-800-677-3838.**
Or, visit us online at **www.utserv.com.**



BEFORE YOU BEGIN

Thank you for selecting the revolutionary PROFORM® HIIT L6 trainer. The HIIT L6 trainer provides an impressive selection of features designed to make your workouts at home more effective and enjoyable.

For your benefit, read this manual carefully before you use the trainer. If you have questions after reading this manual, please see the front cover of this

manual. To help us assist you, note the product model number and serial number before contacting us. The model number and the location of the serial number decal are shown on the front cover of this manual.

Before reading further, please familiarize yourself with the parts that are labeled in the drawing below.

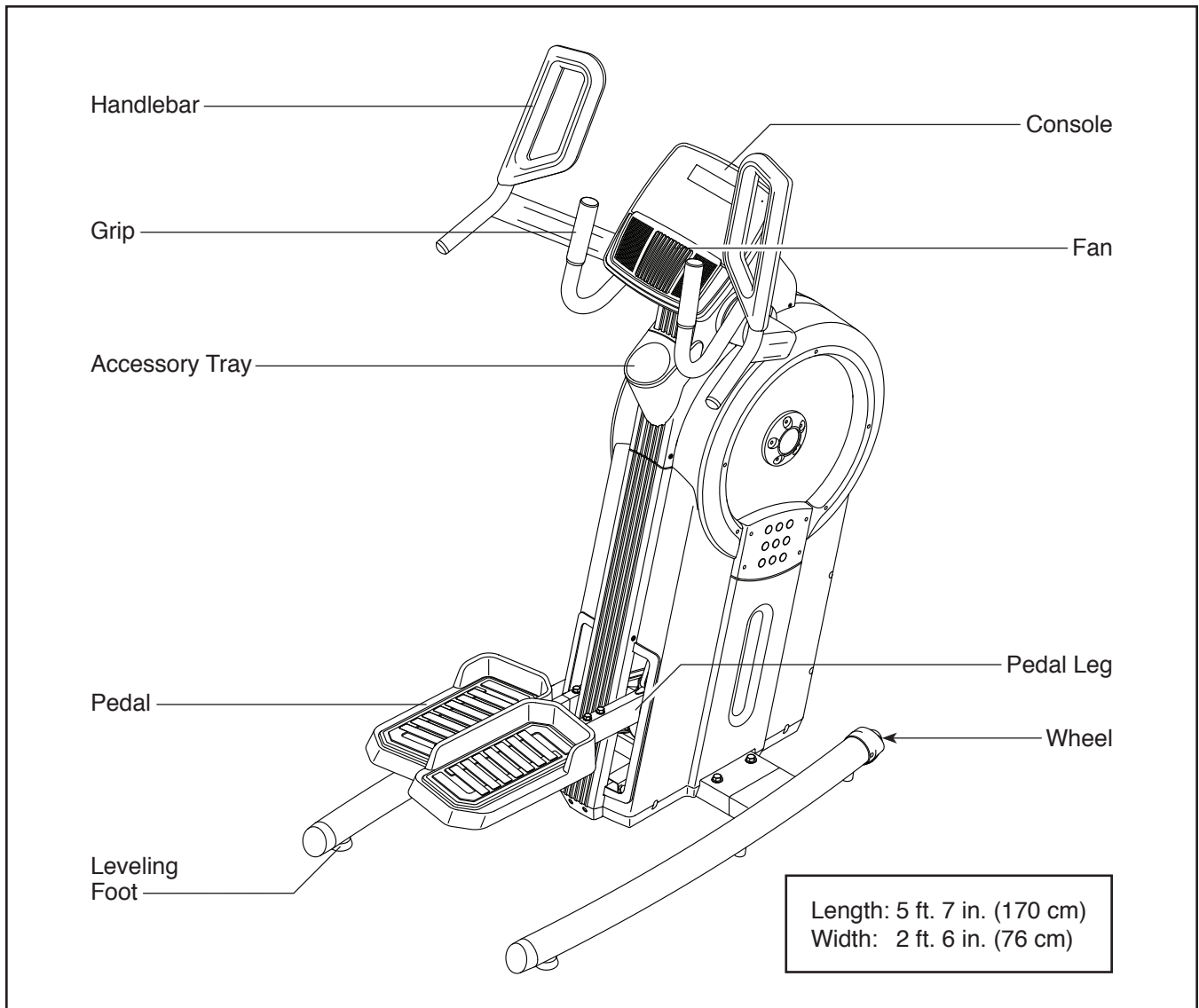

PART IDENTIFICATION CHART

Use the drawings below to identify the small parts needed for assembly. The number in parentheses below each drawing is the key number of the part, from the PART LIST near the end of this manual. The number following the key number is the quantity needed for assembly. **Note: If a part is not in the hardware kit, check to see if it has been preassembled. Extra parts may be included.**

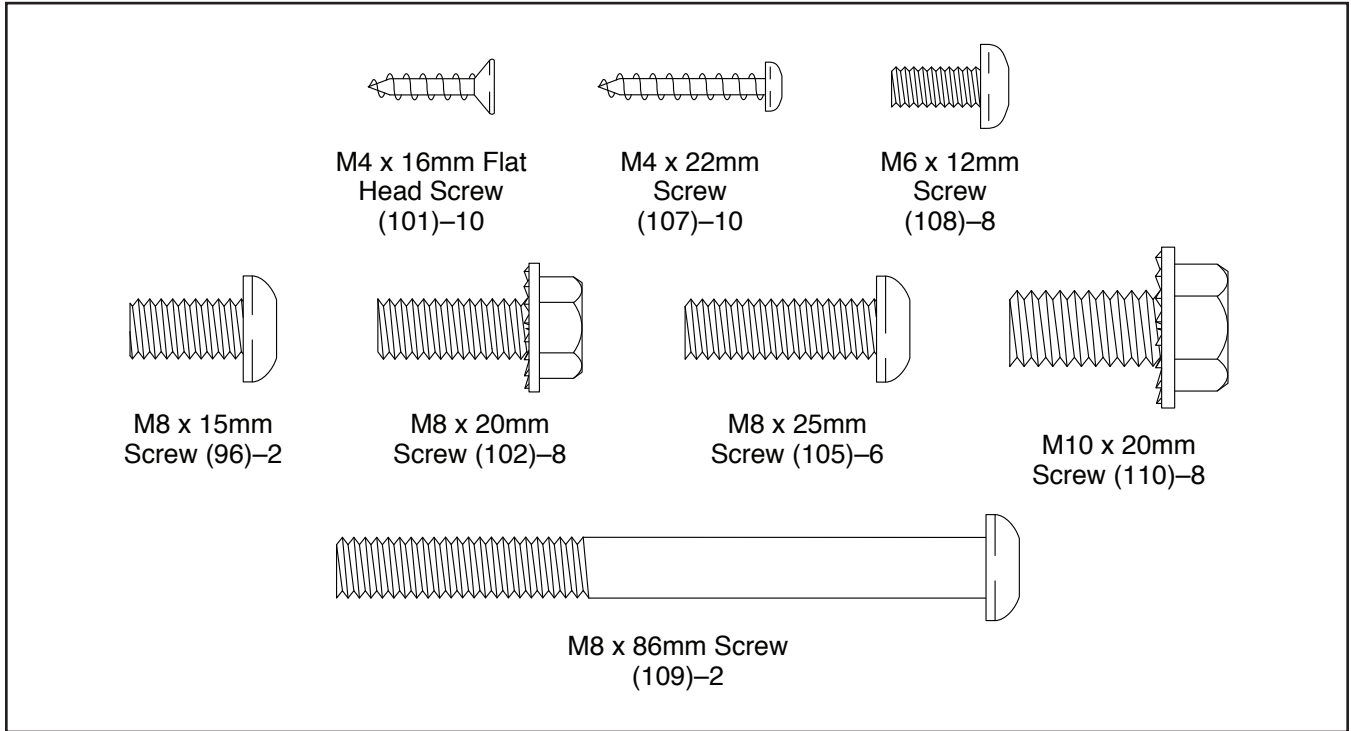

ASSEMBLY

- To hire an authorized service technician to assemble this product, call 1-800-445-2480.
- Assembly requires two persons.
- Place all parts in a cleared area and remove the packing materials. Do not dispose of the packing materials until you finish all assembly steps.
- Left parts are marked “L” or “Left” and right parts are marked “R” or “Right.”

- To identify small parts, see page 6.
- In addition to the included tool(s), assembly requires the following tools:

one Phillips screwdriver

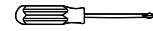

one adjustable wrench



Assembly may be easier if you have your own set of wrenches. To avoid damaging parts, do not use power tools.

1. **Go to my.proform.com on your computer and register your product.**

- documents your ownership
- activates your warranty
- ensures priority customer support if assistance is ever needed

Note: If you do not have internet access, call Customer Care (see the front cover of this manual) and register your product.

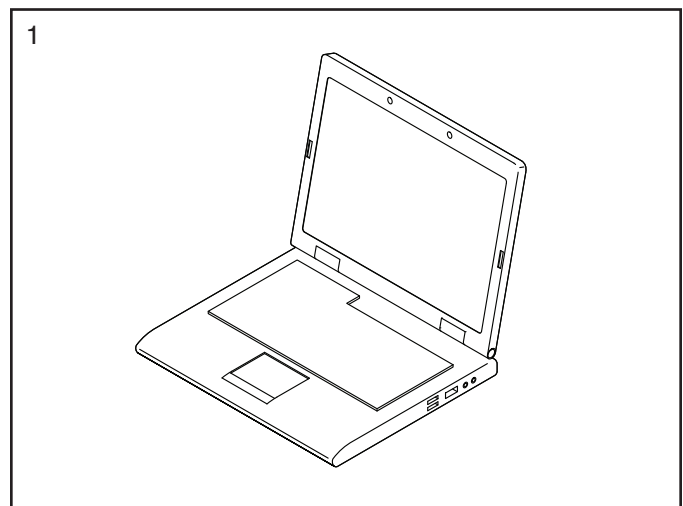

2. Identify the Right and Left Stabilizers (8, 9) and orient them as shown.

Have a second person hold the Frame (1) and tip it to the left. **IMPORTANT: Be careful not to damage the Shields (50, 51).**

Attach the Right Stabilizer (8) to the Frame (1) with four M10 x 20mm Screws (110); **start all the Screws, and then tighten them.**
Note: Disregard the two unthreaded holes in the underside of the Frame.

IMPORTANT: Make sure to tighten the M10 x 20mm Screws (110) firmly and completely.

Have the second person lower the Frame (1) to the floor. **IMPORTANT: Be careful not to damage the Shields (50, 51).**

Attach the Left Stabilizer (9) in the same way.

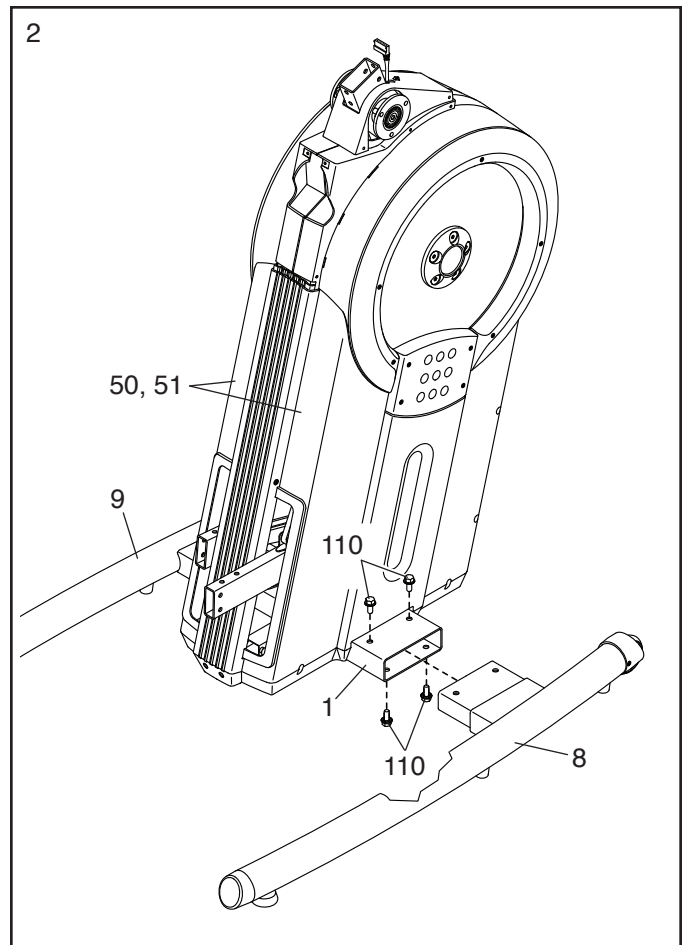

3. Identify the Right and Left Pedal Bases (2, 3) and the Right and Left Pedals (22, 23), and orient them as shown.

Attach the Right Pedal (22) to the Right Pedal Base (2) with four M6 x 12mm Screws (108); **start all the Screws, and then tighten them.**

Attach the Left Pedal (23) to the Left Pedal Base (3) in the same way.

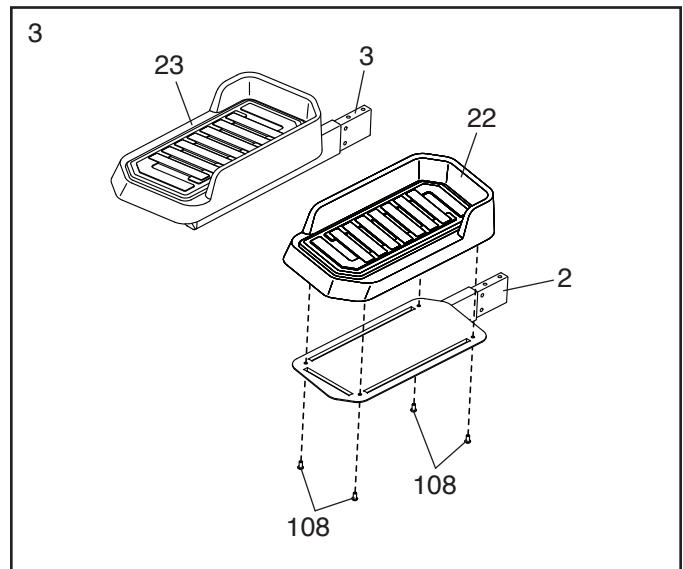

- Attach the Right Pedal Base (2) to the Right Pedal Leg (24) with four M8 x 20mm Screws (102); **start all the Screws, and then tighten them.**

Attach the Left Pedal Base (3) to the Left Pedal Leg (25) in the same way.

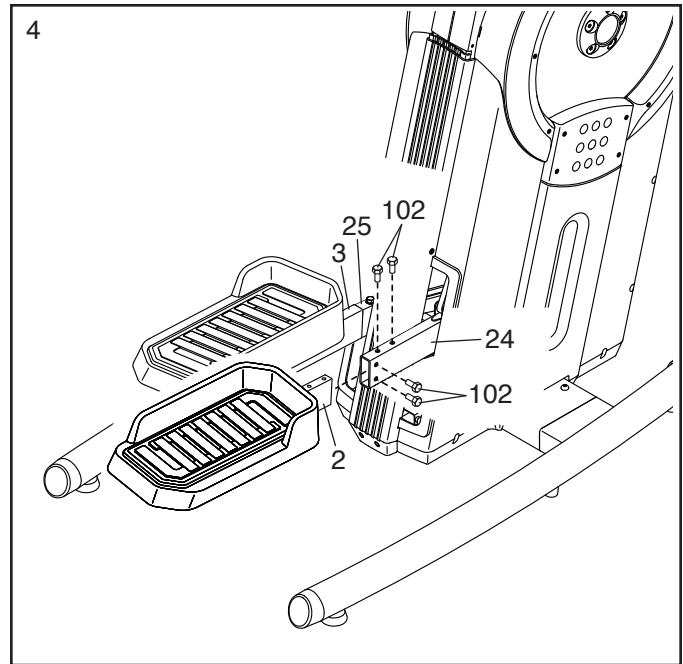

- Press the Rear Cover (53) onto the Left and Right Shields (50, 51).

Attach the Rear Cover (53) with four M4 x 16mm Flat Head Screws (101); **start all the Flat Head Screws, and then tighten them.**

Then, insert the Accessory Tray (18) into the Rear Cover (53).

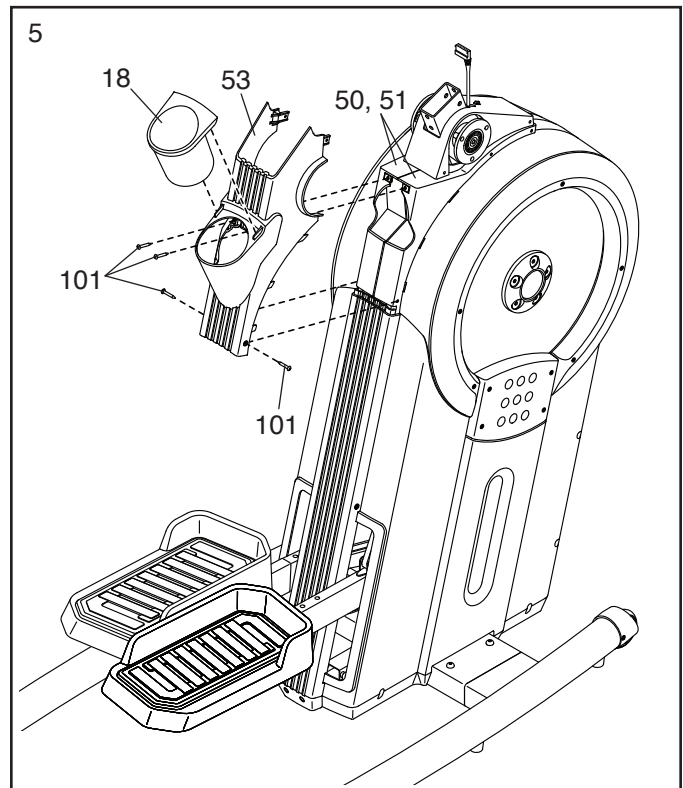

6. **See the upper drawing.** With the help of a second person, orient the Console (5), the Console Cover (7), and the Console Bracket (4) as shown. Then, route the wire (A) on the Console through the Console Cover and the Console Bracket.

See the lower drawing. Tip: Avoid pinching the wire (A). Attach the Console (5) and the Console Cover (7) to the Console Bracket (4) with four M4 x 22mm Screws (107); **start all the Screws, and then tighten them.**

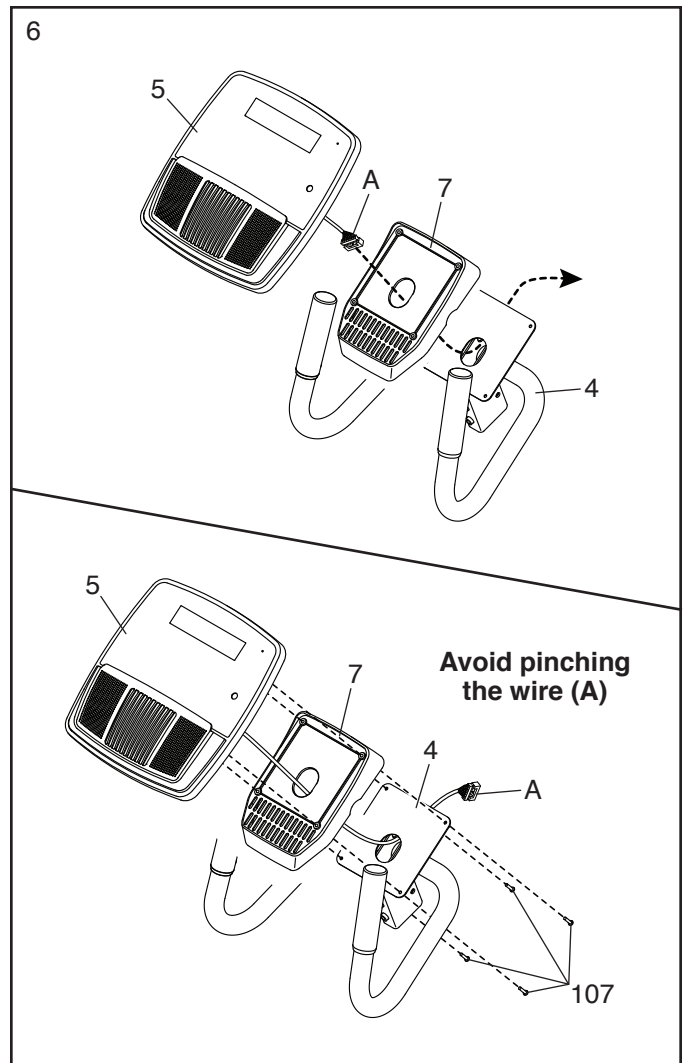

7. While a second person holds the Console Bracket (4) near the Frame (1), connect the wire (A) on the Console (5) to the Main Wire (115).

Tip: Avoid pinching the wires. Attach the Console Bracket (4) to the Frame (1) with two M8 x 86mm Screws (109) and two M8 x 15mm Screws (96); **start all the Screws, and then tighten them.**

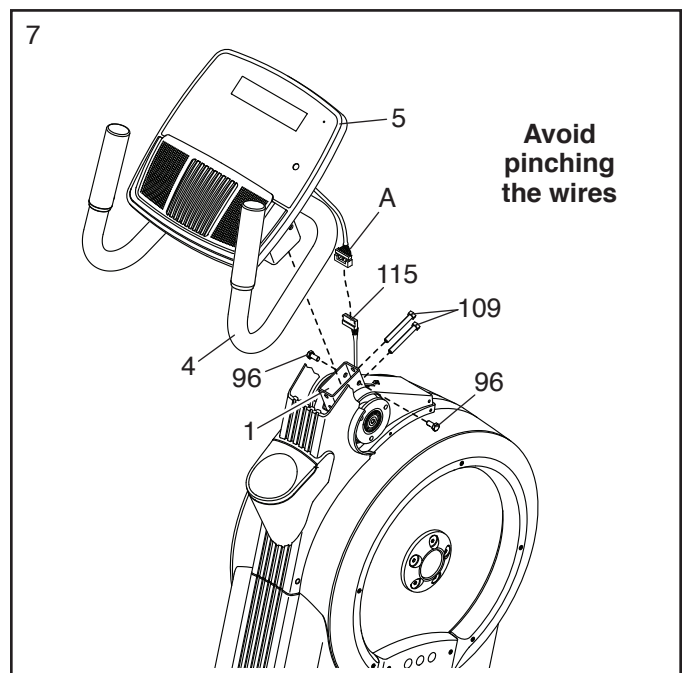

8. Identify the Right and Left Handlebars (10, 11).

Make sure that the Pedals (22, 23) are level. Attach the Right Handlebar (10) to the Right Handlebar Arm (15) with three M8 x 25mm Screws (105); **start all the Screws, and then tighten them.** **Tip: It may be helpful to rotate the Right Handlebar for better access to tighten the Screws.**

Attach the Left Handlebar (11) in the same way.

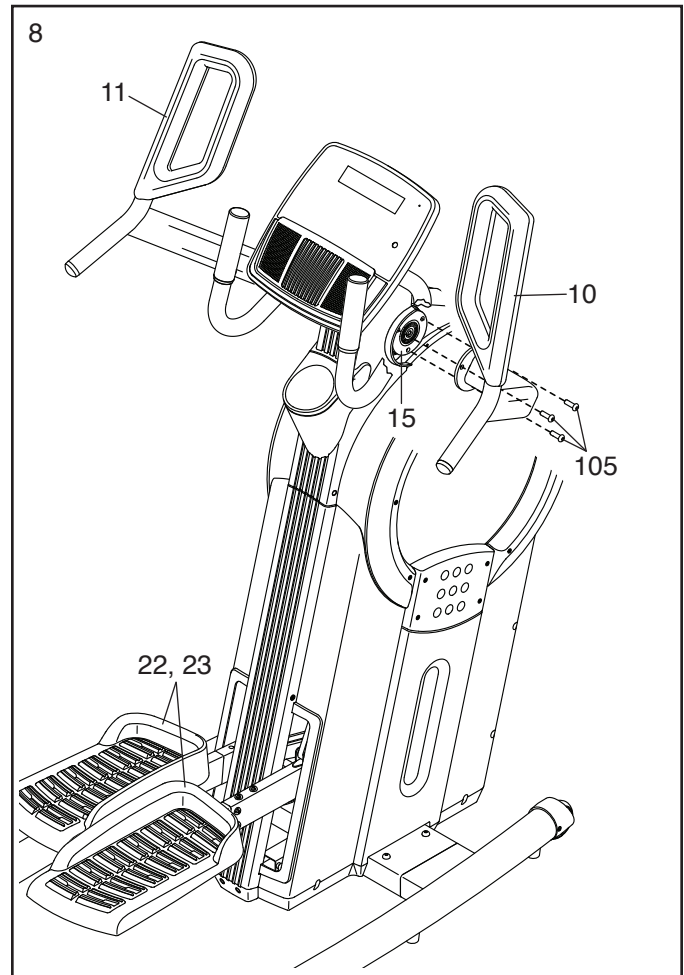

9. Identify the Rear and Front Pivot Covers (65, 66).

Press a set of Rear and Front Pivot Covers (65, 66) together around the Right Handlebar (10) near the bend (B). Then, attach them to each other with two M4 x 22mm Screws (107).

See the inset drawing. Slide the Rear and Front Pivot Covers (65, 66) toward the Shield Cover (12). Attach the Front Pivot Cover to the Right Handlebar (10) with an M4 x 22mm Screw (107).

Repeat this step on the other side of the trainer.

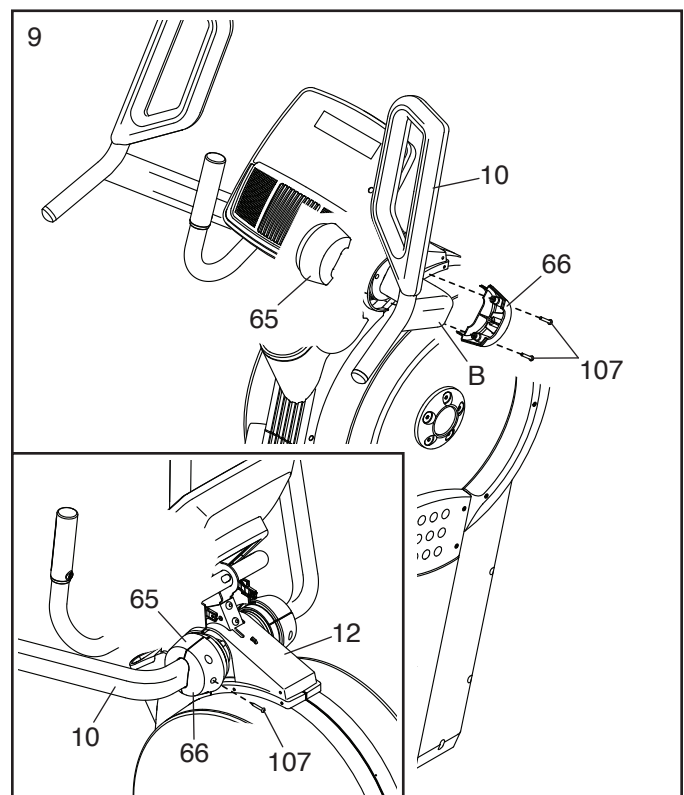

10. Attach the Front Cover (52) to the Left and Right Shields (50, 51) with six M4 x 16mm Flat Head Screws (101); **start all the Flat Head Screws, and then tighten them.**

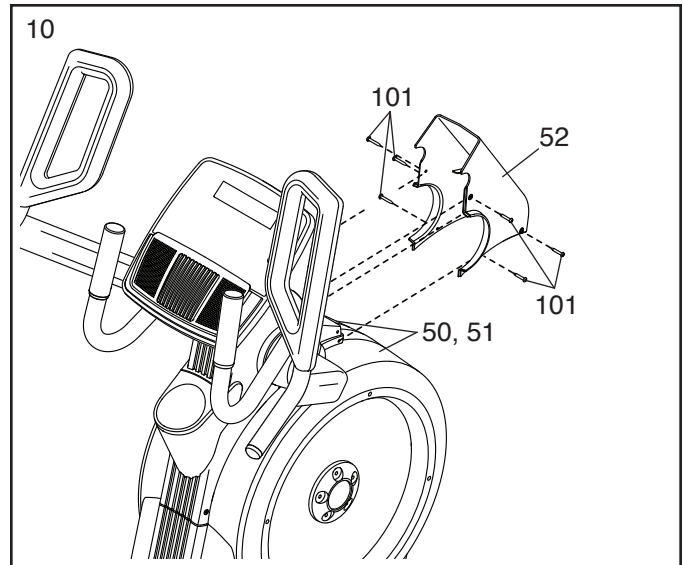

11. **Make sure that all parts are properly tightened.** Extra parts may be included. Place a mat beneath the trainer to protect the floor.

Plug the Power Adapter (118) into the receptacle on the front of the trainer.

Then, plug the Power Adapter (118) into an outlet (see HOW TO PLUG IN THE POWER ADAPTER on page 13).

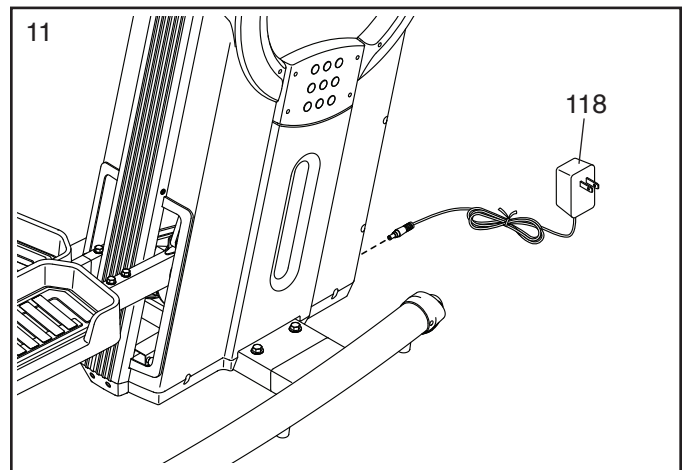

12. **IMPORTANT: You must activate your Console (5) to begin using its exclusive features.**

First, press any button on the Console (5) to turn on the power.

Then, using your smartphone or tablet, go to **iFit.com/activate** and follow the instructions to activate the Console (5).

Note: If you do not have a smartphone or tablet, use your computer to go to **iFit.com/activate** for an alternate way to activate the Console (5). If you do not have a computer, call Customer Care (see the front cover of this manual).

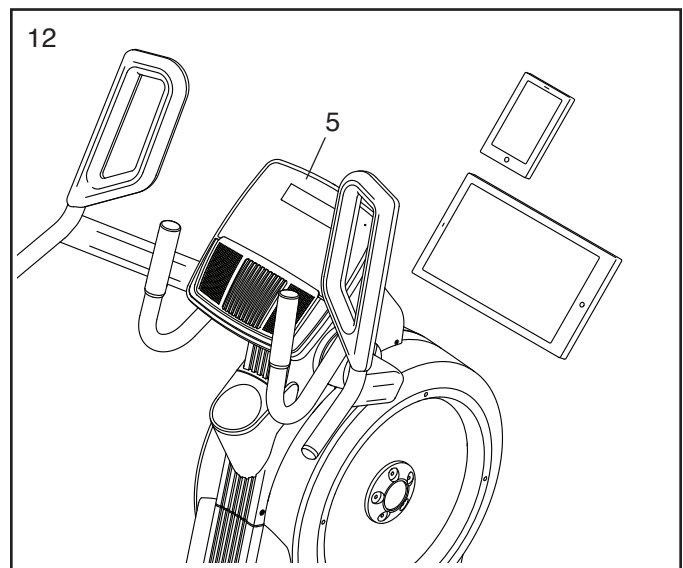

HOW TO USE THE TRAINER

HOW TO PLUG IN THE POWER ADAPTER

IMPORTANT: If the trainer has been exposed to cold temperatures, allow it to warm to room temperature before you plug in the power adapter. If you do not do this, you may damage the console displays or other electronic components.

Plug the power adapter (A) into the receptacle on the front of the trainer. Then, plug the power adapter into an appropriate outlet that is properly installed in accordance with all local codes and ordinances.

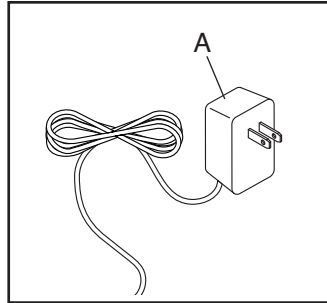

HOW TO MOVE THE TRAINER

Due to the size and weight of the trainer, moving it requires two persons. Stand in front of the trainer, hold the console bracket (B), and place one foot against one of the wheels (C). Have a second person help you pull on the console bracket until the trainer will roll on the wheels. Carefully move the trainer to the desired location, and then lower it to the floor.

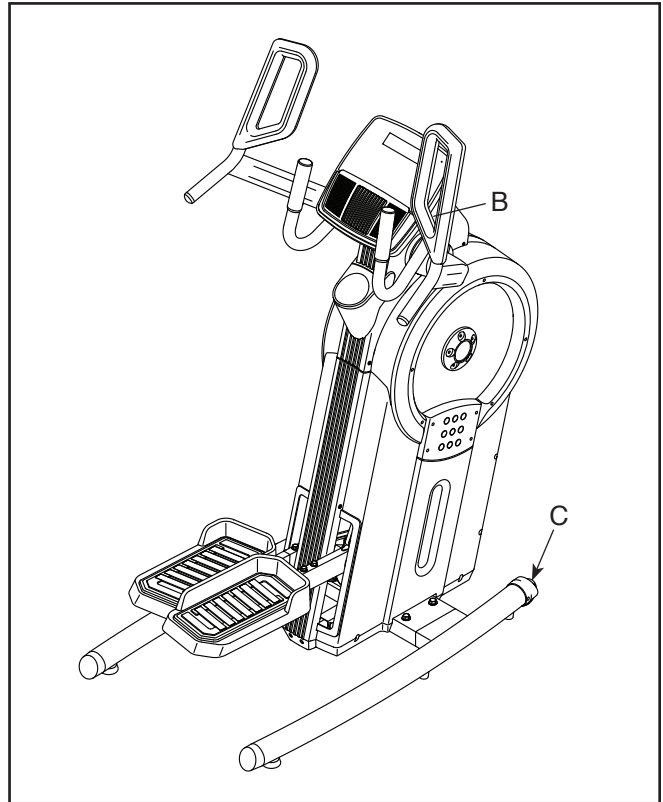

HOW TO EXERCISE ON THE TRAINER

To mount the trainer, hold the handlebars (D) or the grips (E) and step onto the pedal (F) that is in the lower position. Then, step onto the other pedal. Push the pedals until they begin to move with a continuous motion. **Note: The pedals can turn in either direction. It is recommended that you turn the pedals in the direction shown by the arrow; however, for variety, you can turn the pedals in the opposite direction.**

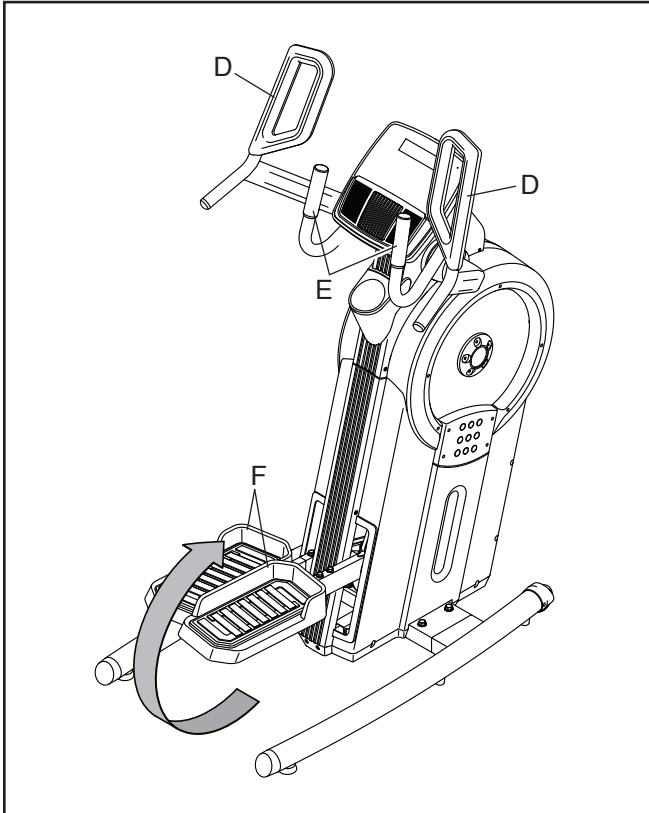

To dismount the trainer, wait until the pedals (F) come to a complete stop. **Note: The trainer does not have a free wheel; the pedals will continue to move until the flywheel stops.** When the pedals are stationary, step off the higher pedal first. Then, step off the lower pedal.

HOW TO LEVEL THE TRAINER

If the trainer rocks slightly on your floor during use, turn one or both of the leveling feet (G) beneath the stabilizers until the rocking motion is eliminated.

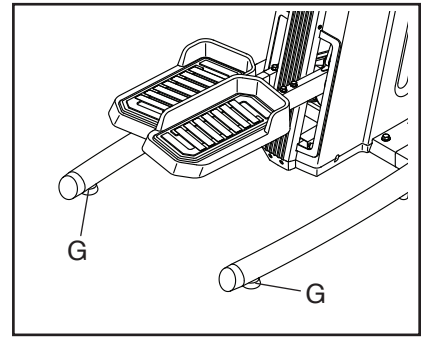

THE OPTIONAL TABLET HOLDER

The optional tablet holder (H) will hold your tablet securely in place and enable you to use your tablet while you exercise. The optional tablet holder is designed for use with most full-size tablets.

To purchase a tablet holder, please see the front cover of this manual.

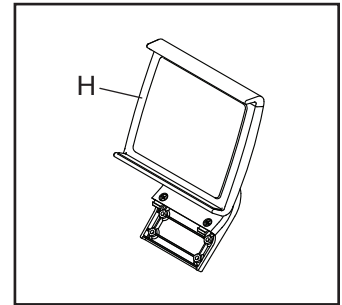

HOW TO USE THE CONSOLE

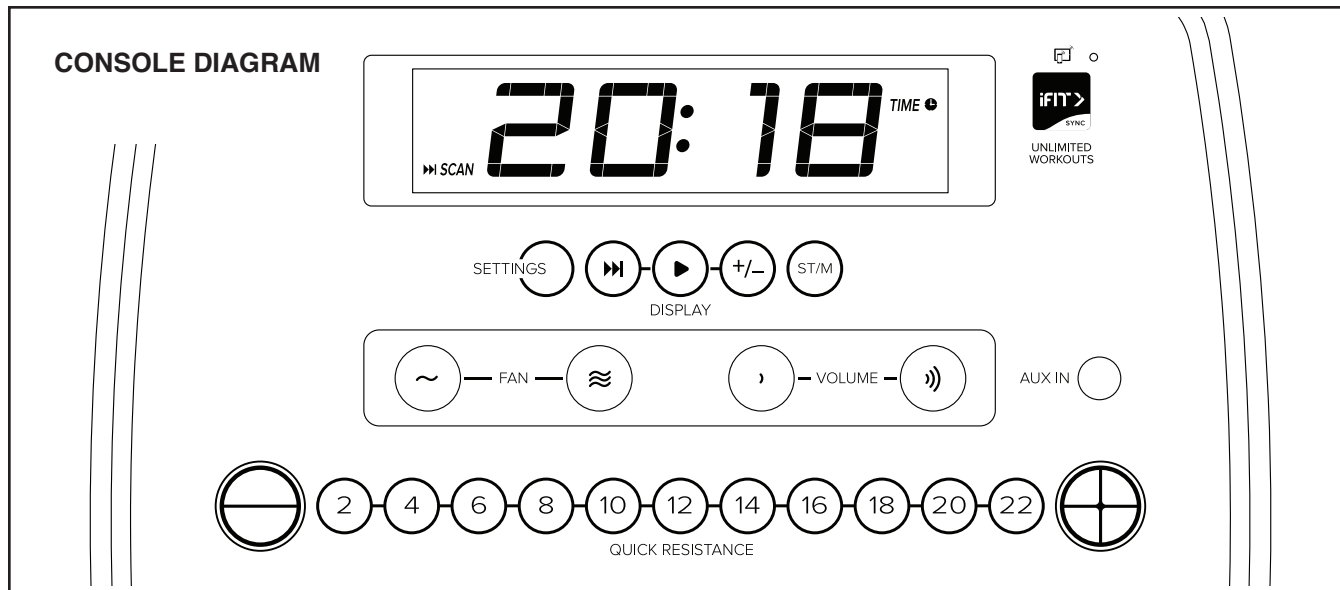

FEATURES OF THE CONSOLE

IMPORTANT: To activate your console and begin using its exclusive features, see assembly step 12 on page 12.

The advanced console offers an array of features designed to make your workouts more effective and enjoyable.

When you use the manual mode of the console, you can change the resistance of the pedals with the touch of a button. As you exercise, the console will provide continuous exercise feedback. You can even measure your heart rate using a compatible heart rate monitor.

You can connect your personal audio player to the console sound system and listen to your favorite music or audio books while you exercise.

The console also offers unlimited iFit workouts when you download the iFit app to your smart device and connect it to the console.

With the iFit app, you can access a large and varied library of iFit video workouts, create your own workouts, track your workout results, and access many other features.

Each iFit workout automatically changes the resistance of the pedals as an iFit coach guides you through an immersive and effective video workout.

To use the manual mode, see page 16. To use the sound system, see page 18.

To use an iFit workout, see page 18. To connect your heart rate monitor to the console, see page 19. To change console settings, see page 20.

Note: If there is a sheet of plastic on the display, remove the plastic.

Note: The console can display speed and distance in standard or metric units. To change the unit of measurement, press the St/M button repeatedly. For simplicity, all instructions in this section refer to standard units.

HOW TO USE THE MANUAL MODE

1. **Begin pedaling or press any button on the console to turn on the console.**

When you turn on the console, the display will turn on. The console will then be ready for use.

2. **Select the manual mode.**

When you turn on the console, the manual mode will be selected automatically.

3. **Change the resistance of the pedals as desired.**

Begin pedaling to start the manual mode.

As you pedal, you can change the resistance of the pedals. To change the resistance, press one of the numbered Quick Resistance buttons or press the Quick Resistance increase and decrease buttons.

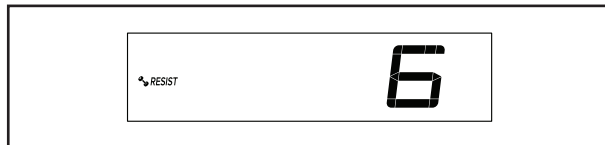

Note: After you press a button, it will take a moment for the pedals to reach the selected resistance level.

4. **Follow your progress with the display.**

The display can show the following workout information:

Calories (CALs)—The approximate number of calories you have burned.

Calories per Hour (CALs/HR)—The approximate number of calories you are burning per hour.

Distance (MI or KM)—The distance that you have pedaled in miles or kilometers. To change the unit of measurement, press the St/M button.

Pace—Your pedaling speed in minutes per mile or minutes per kilometer. To change the unit of measurement, press the St/M button.

Pulse (BPM and heart symbol)—Your heart rate when you use a compatible heart rate monitor (see step 5).

Resistance (RESIST)—The resistance level of the pedals.

RPM—Your pedaling speed in revolutions per minute (RPM).

Speed (MPH or KPH)—Your pedaling speed in miles per hour or kilometers per hour. To change the unit of measurement, press the St/M button.

Time—The elapsed time.

Vertical Distance—Your vertical distance in feet or meters.

Press the Display button (A) repeatedly to view the desired workout information in the display.

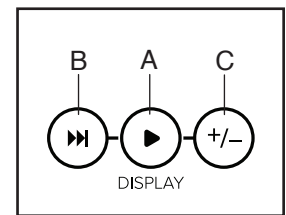

Scan mode—The console also has a scan mode that will display workout information in a repeating cycle. To turn on the scan mode, press the Scan button (B); the scan indicator (D) and the word SCAN will turn on in the display.



To manually advance the scan cycle, press the Scan button repeatedly.

To turn off the scan mode, press the Display button; the scan indicator and the word SCAN will turn off.

You can also customize the scan mode to display only the desired workout information in the repeating cycle.

To customize the scan mode, first press the Display button repeatedly until the workout information that you want to add to or remove from the scan cycle appears in the display.

Next, press the Add/Remove button (C) to add or remove that workout information from the scan cycle. **When workout information is added**, its indicator will turn on in the display. **When workout information is removed**, its indicator will turn off.

Then, press the Scan button to turn on the scan mode.

Note: The console will show your heart rate in the scan cycle automatically whenever it detects a pulse from a heart rate monitor.

To change the volume level of the console, press the Volume increase and decrease buttons.

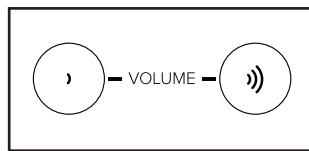

To pause the console, simply stop pedaling. When the console is paused, the time will flash in the display. To continue your workout, simply resume pedaling.

5. Wear a compatible heart rate monitor and measure your heart rate if desired.

You can wear a compatible heart rate monitor to measure your heart rate. Note: The console is compatible with all Bluetooth® Smart heart rate monitors.

A compatible chest heart rate monitor is included with some models. If a chest heart rate monitor is included, see THE CHEST HEART RATE MONITOR in this manual to learn how to use it.

If this model does not include a compatible heart rate monitor, see page 19 for information about ordering one.

To connect a compatible heart rate monitor to the console, press the iFit Sync button on the console; the console pairing number will appear in the display. When a connection is established, the LED on the console will flash red twice. When your heart-beat is detected, your heart rate will be shown. See HOW TO CONNECT YOUR HEART RATE MONITOR TO THE CONSOLE on page 19 for more information.

6. Turn on the fan if desired.

The fan has several speed settings. Press the Fan increase and decrease buttons repeatedly to select a fan speed or to turn off the fan.

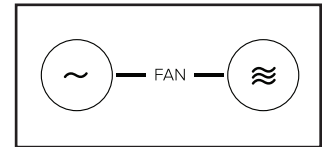

Note: If the pedals do not move for about 30 seconds, the fan will turn off automatically.

7. When you are finished exercising, the console will turn off automatically.

If the pedals do not move for several seconds, the console will pause and the time will flash in the display. To resume your workout, simply resume pedaling.

If the pedals do not move for several minutes and the buttons are not pressed, the console will turn off and the display will be reset.

Note: The console features a demo mode, designed to be used if the trainer is displayed in a store. If the demo mode is turned on, the console will not turn off and the display will not be reset when you finish exercising. To turn off the demo mode, see HOW TO CHANGE CONSOLE SETTINGS on page 20.

HOW TO USE THE SOUND SYSTEM

To play music or audio books through the console sound system while you exercise, plug a 3.5 mm male to 3.5 mm male audio cable (not included) into the jack on the console and into a jack on your personal audio player; **make sure that the audio cable is fully plugged in. Note: To purchase an audio cable, see your local electronics store.**

Next, press the play button on your personal audio player. Adjust the volume level using the Volume increase and decrease buttons on the console or the volume control on your personal audio player.

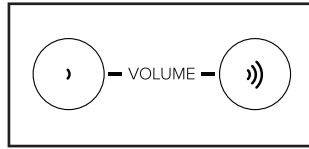

HOW TO USE AN IFIT WORKOUT

The console offers access to a large and varied library of iFit workouts when you download the iFit app to your smart device and connect it to the console.

Note: The console supports Bluetooth connections to smart devices via the iFit app and to compatible heart rate monitors. Other Bluetooth connections are not supported.

1. Download and install the iFit app on your smart device.

On your iOS® or Android™ smart device, open the App StoreSM or the Google Play™ store, search for the free iFit app, and then install the app on your smart device. **Make sure that the Bluetooth option is enabled on your smart device.**

Then, open the iFit app and follow the instructions to set up an iFit account and customize settings.

Take time to explore the iFit app and learn about its features and settings.

2. Connect your heart rate monitor to the console if desired.

If you are connecting both your heart rate monitor and your smart device to the console, **you must connect your heart rate monitor before you connect your smart device.** See HOW TO CONNECT YOUR HEART RATE MONITOR TO THE CONSOLE on page 19.

3. Connect your smart device to the console.

Press the iFit Sync button on the console; the console pairing number will appear in the display. Then, follow the instructions in the iFit app to connect your smart device to the console.

When a connection is established, the LED on the console will turn solid blue.

4. Select an iFit workout.

In the iFit app, touch the buttons at the bottom of the screen to select either the main menu (Home button) or the workout library (Browse button).

To select a workout from the main menu or the workout library, simply touch the desired workout button on the screen. Slide or flick the screen to scroll upward or downward if necessary.

When you select a workout, the screen will show an overview of the workout that includes details such as the duration and distance of the workout and the approximate number of calories you will burn during the workout.

5. Start the workout.

Touch *Start Workout* to start the workout.

During some workouts, an iFit coach will guide you through a video workout. Touch the sound button (music notes symbol) to select music, trainer voice, and volume options for the workout.

During some workouts, the screen will show a map of the route and a marker indicating your progress. Touch the buttons on the screen to select the desired map options.

If the resistance setting for the current segment of the workout is too high or too low, you can manually override the setting by pressing the Quick Resistance buttons on the console. **IMPORTANT: When the current segment ends, the resistance will automatically adjust to the resistance setting programmed for the next segment.**

Note: The calorie goal shown in the workout description is an estimate of the number of calories that you will burn during the workout. The actual number of calories that you burn will depend on various factors, such as your weight. In addition, if you manually change the resistance level during the workout, the number of calories you burn will be affected.

To pause the workout, simply touch the screen or stop pedaling. To continue the workout, simply resume pedaling.

To end the workout, touch the screen to pause the workout, and then follow the prompts on the screen to end the workout and return to the main menu.

When the workout ends, a workout summary will appear on the screen. If desired, you can select options such as adding the workout to your schedule or adding the workout to your favorites list. Then, touch *Save Workout* to return to the main menu.

6. Disconnect your smart device from the console.

To disconnect your smart device from the console, first select the disconnect option in the iFit app. Then, press and hold the iFit Sync button on the console until the LED on the console turns solid green.

Note: All Bluetooth connections between the console and other devices (including any smart devices, heart rate monitors, and so forth) will be disconnected.

7. When you are finished exercising, the console will turn off automatically.

If the pedals do not move for several seconds, the console will pause.

If the pedals do not move for several minutes and the buttons are not pressed, the console will turn off and the display will be reset.

HOW TO CONNECT YOUR HEART RATE MONITOR TO THE CONSOLE

The console is compatible with all Bluetooth Smart heart rate monitors.

To connect your Bluetooth Smart heart rate monitor to the console, press the iFit Sync button on the console; the console pairing number will appear in the display. When a connection is established, the LED on the console will flash red twice.

Note: If there is more than one compatible heart rate monitor near the console, the console will connect to the heart rate monitor with the strongest signal.

To disconnect your heart rate monitor from the console, press and hold the iFit Sync button on the console until the LED on the console turns solid green.

Note: All Bluetooth connections between the console and other devices (including any smart devices, heart rate monitors, and so forth) will be disconnected.

THE OPTIONAL CHEST HEART RATE MONITOR

Whether your goal is to burn fat or to strengthen your cardiovascular system, the key to achieving the best results is to maintain the proper heart rate during your

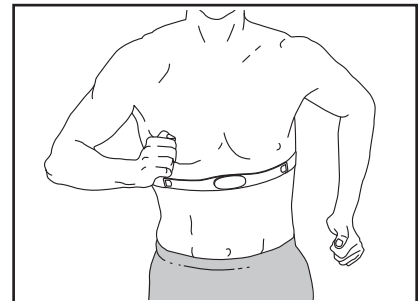

workouts. The optional chest heart rate monitor will enable you to continuously monitor your heart rate while you exercise, helping you to reach your personal fitness goals. **To purchase a chest heart rate monitor, please see the front cover of this manual.**

Note: The console is compatible with all Bluetooth Smart heart rate monitors.

HOW TO CHANGE CONSOLE SETTINGS

1. Select the settings mode.

To select the settings mode, press the Settings button. The first settings screen will appear in the display.

Note: If you are using the manual mode or an iFit workout, end your workout before you press the Settings button.

2. Navigate the settings mode.

While the settings mode is selected, you can navigate through several settings screens. Press the Display button repeatedly to select the desired settings screen.

3. Change settings as desired.

Software Version Number—The software version number will appear in the display.

Unit of Measurement—The currently selected unit of measurement will appear in the display. The console can show speed and distance in standard or metric units of measurement. To change the unit of measurement, press the St/M button repeatedly. To view workout information in standard units, select STD. To view workout information in metric units, select MET.



Display Test—This screen is intended to be used by service technicians to identify whether the display is working correctly.

Button Test—This screen is intended to be used by service technicians to identify whether a certain button is working correctly.

Total Time—The word TIME will appear in the display. The display will show the total number of hours that the trainer has been used.

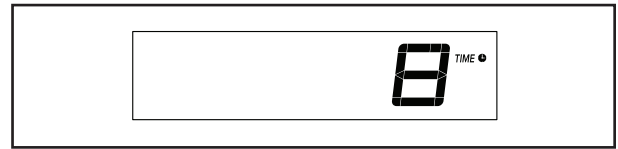

Total Distance—The letters MI or KM will appear in the display. The display will show the total distance (in miles or kilometers) that the trainer has been pedaled.

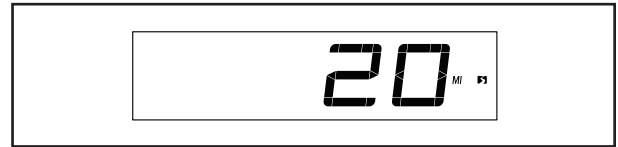

Contrast Level—The currently selected contrast level will appear in the display. Press the Quick Resistance increase and decrease buttons to adjust the contrast level.

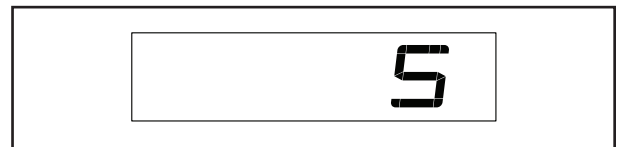

Demo Mode—The currently selected demo mode option will appear in the display. The console features a demo mode, designed to be used if the trainer is displayed in a store. If the demo mode is turned on, the console will not turn off and the display will not be reset when you finish exercising. Press the Quick Resistance increase button repeatedly to select a demo mode option. To turn on the demo mode, select DON. To turn off the demo mode, select DOFF.



4. Exit the settings mode.

Press the Settings button to exit the settings mode.

MAINTENANCE AND TROUBLESHOOTING

MAINTENANCE

Regular maintenance is important for optimal performance and to reduce wear. Inspect and properly tighten all parts each time the trainer is used. Replace any worn parts immediately.

To clean the trainer, use a damp cloth and a small amount of mild soap. **IMPORTANT: To avoid damage to the console, keep liquids away from the console and keep the console out of direct sunlight.**

CONSOLE TROUBLESHOOTING

The console requires activation. If you have not activated the console, see assembly step 12 on page 12.

If the console does not turn on, make sure that the power adapter is fully plugged in.

If a replacement power adapter is needed, call the telephone number on the cover of this manual. IMPORTANT: To avoid damaging the console, use only a manufacturer-supplied regulated power adapter.

If lines appear in the console display, see step 3 on page 20 and adjust the contrast level of the display.

PEDAL TROUBLESHOOTING

If the pedals bottom out while you are exercising and become difficult to move, rock your weight backward and forward on the pedals until the pedals become unstuck and the flywheel inside the trainer begins turning again.

HOW TO ADJUST THE REED SWITCH

If the console does not display correct feedback, the reed switch should be adjusted. To adjust the reed switch, first **unplug the power adapter**.

Next, remove the four indicated M4 x 16mm Flat Head Screws (101) and the Lower Rear Shield Cover (68).

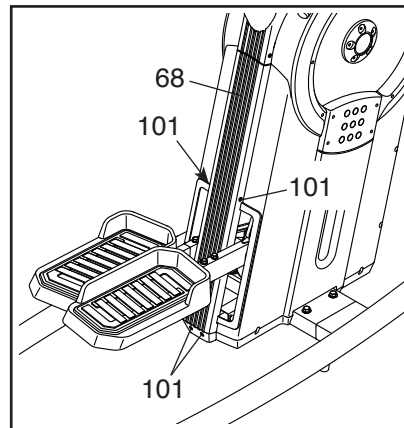

Next, turn the Large Pulley (21) until a Pulley Magnet (104) is aligned with the Reed Switch (116). Then, slightly loosen the M4 x 19mm Screw (113), slide the Reed Switch slightly closer to or away from the Pulley Magnet, and retighten the Screw.

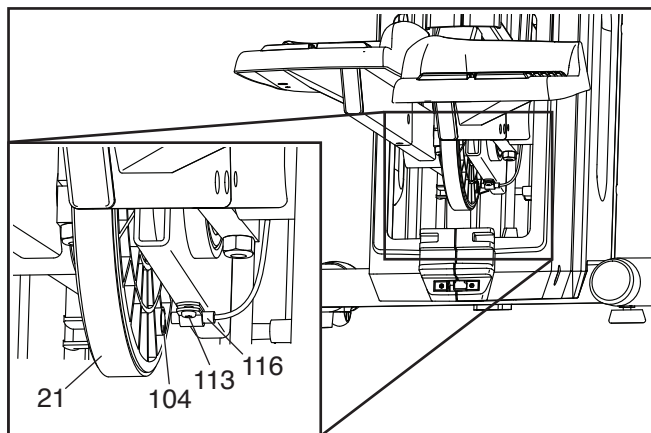

Then, plug in the power adapter and turn the Large Pulley (21) for a moment. Repeat these actions, if necessary, until the console displays correct feedback. Then, reattach the lower rear shield cover.

HOW TO ADJUST THE DRIVE BELT

If the pedals slip while you are pedaling, even while the resistance is adjusted to the highest level, the drive belts may need to be adjusted. To adjust the drive belts, first **unplug the power adapter**.

Next, remove the four indicated M4 x 16mm Flat Head Screws (101) and the Lower Rear Shield Cover (68).

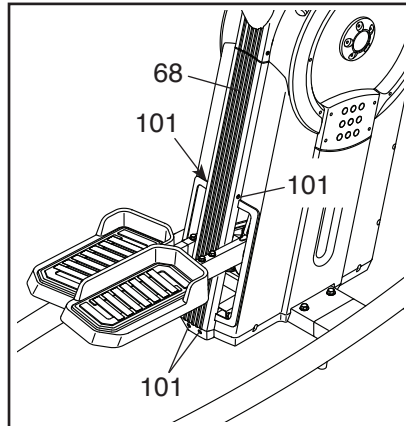

Then, locate the lower Adjustment Screw (A). Tighten the lower Adjustment Screw four turns; this will tighten the Large Drive Belt (31).

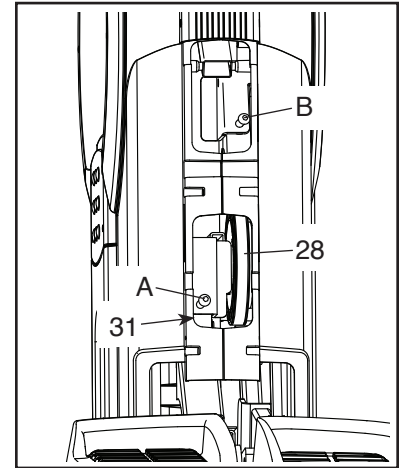

Stand on the trainer and pedal for a few moments. If the pedals still slip, step off the trainer and locate the upper Adjustment Screw (B). Tighten the upper Adjustment Screw two turns; this will tighten the Small Drive Belt (28).

Stand on the trainer again and pedal for a few moments. If the pedals still slip, step off the trainer and tighten the lower Adjustment Screw (A) four turns; this will again tighten the Large Drive Belt (31).

When you have properly adjusted the drive belts, reattach the lower rear shield cover.

FCC INFORMATION

This equipment has been tested and found to comply with the limits for a Class B digital device, pursuant to part 15 of the FCC Rules. These limits are designed to provide reasonable protection against harmful interference in a residential installation. This equipment generates, uses, and can radiate radio frequency energy and, if not installed and used in accordance with the instructions, may cause harmful interference to radio communications. However, there is no guarantee that interference will not occur in a particular installation. If this equipment does cause harmful interference to radio or television reception, which can be determined by turning the equipment off and on, try to correct the interference by one or more of the following measures:

- Reorient or relocate the receiving antenna.
- Increase the separation between the equipment and the receiver.
- Connect the equipment into an outlet on a circuit different from that to which the receiver is connected.
- Consult the dealer or an experienced radio/TV technician for help.

FCC CAUTION: To assure continued compliance, use only shielded interface cables when connecting to computer or peripheral devices. Changes or modifications not expressly approved by the party responsible for compliance could void the user's authority to operate this equipment.

IMPORTANT: To satisfy exposure compliance requirements, the antenna and transmitter in the console must be at least 8 in. (20 cm) from all persons and must not be near or connected to any other antenna or transmitter.

Note: The console contains FCC ID: OMCBMD1.

EXERCISE GUIDELINES

⚠️ WARNING: Before beginning this or any exercise program, consult your physician. This is especially important for persons over age 35 or persons with pre-existing health problems.

These guidelines will help you to plan your exercise program. For detailed exercise information, obtain a reputable book or consult your physician. Remember, proper nutrition and adequate rest are essential for successful results.

EXERCISE INTENSITY

Whether your goal is to burn fat or to strengthen your cardiovascular system, exercising at the proper intensity is the key to achieving results. You can use your heart rate as a guide to find the proper intensity level. The chart below shows recommended heart rates for fat burning and aerobic exercise.

165	155	145	140	130	125	115	♥️
145	138	130	125	118	110	103	♥️
125	120	115	110	105	95	90	♥️
<hr/>							
20	30	40	50	60	70	80	

To find the proper intensity level, find your age at the bottom of the chart (ages are rounded off to the nearest ten years). The three numbers listed above your age define your “training zone.” The lowest number is the heart rate for fat burning, the middle number is the heart rate for maximum fat burning, and the highest number is the heart rate for aerobic exercise.

Burning Fat—To burn fat effectively, you must exercise at a low intensity level for a sustained period of time. During the first few minutes of exercise, your body uses carbohydrate calories for energy. Only after the first few minutes of exercise does your body begin to use stored fat calories for energy. If your goal is to burn fat, adjust the intensity of your exercise until your heart rate is near the lowest number in your training zone. For maximum fat burning, exercise with your heart rate near the middle number in your training zone.

Aerobic Exercise—If your goal is to strengthen your cardiovascular system, you must perform aerobic exercise, which is activity that requires large amounts of oxygen for prolonged periods of time. For aerobic exercise, adjust the intensity of your exercise until your heart rate is near the highest number in your training zone.

HOW TO MEASURE YOUR HEART RATE

To measure your heart rate, exercise for at least four minutes. Then, stop exercising and place two fingers on your wrist as shown. Take a six-second heartbeat count, and multiply the result by 10 to find your heart rate. For example, if your six-second heartbeat count is 14, your heart rate is 140 beats per minute.

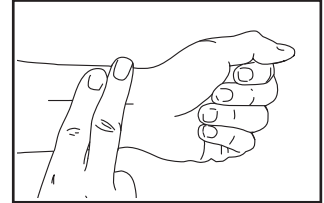

WORKOUT GUIDELINES

Warming Up—Start with 5 to 10 minutes of stretching and light exercise. A warm-up increases your body temperature, heart rate, and circulation in preparation for exercise.

Training Zone Exercise—Exercise for 20 to 30 minutes with your heart rate in your training zone. (During the first few weeks of your exercise program, do not keep your heart rate in your training zone for longer than 20 minutes.) Breathe regularly and deeply as you exercise—never hold your breath.

Cooling Down—Finish with 5 to 10 minutes of stretching. Stretching increases the flexibility of your muscles and helps to prevent post-exercise problems.

EXERCISE FREQUENCY

To maintain or improve your condition, complete three workouts each week, with at least one day of rest between workouts. After a few months of regular exercise, you may complete up to five workouts each week, if desired. Remember, the key to success is to make exercise a regular and enjoyable part of your everyday life.

PART LIST

Model No. PFEL07920.0 R0920A

Key No.	Qty.	Description	Key No.	Qty.	Description
1	1	Frame	51	1	Right Shield
2	1	Right Pedal Base	52	1	Front Cover
3	1	Left Pedal Base	53	1	Rear Cover
4	1	Console Bracket	54	1	Accessory Tray Base
5	1	Console	55	2	Stabilizer Cap
6	2	Snap Ring	56	4	Foot
7	1	Console Cover	57	2	Wheel
8	1	Right Stabilizer	58	1	Right Wheel Cover
9	1	Left Stabilizer	59	2	Handlebar Cap
10	1	Right Handlebar	60	2	Disc Axle Bearing
11	1	Left Handlebar	61	1	Left Rear Handlebar Cover
12	1	Shield Cover	62	1	Left Front Handlebar Cover
13	2	Grip	63	1	Right Rear Handlebar Cover
14	1	Left Handlebar Arm	64	1	Right Front Handlebar Cover
15	1	Right Handlebar Arm	65	2	Rear Pivot Cover
16	1	Magnet Bracket	66	2	Front Pivot Cover
17	2	Idler	67	1	Spring
18	1	Accessory Tray	68	1	Lower Rear Shield Cover
19	1	Exchange Axle	69	2	Leveling Foot
20	1	Medium Pulley	70	10	Small Bearing
21	1	Large Pulley	71	4	Medium Bearing
22	1	Right Pedal	72	2	Large Bearing
23	1	Left Pedal	73	8	Bushing
24	1	Right Pedal Leg	74	2	Large Spacer
25	1	Left Pedal Leg	75	2	Small Spacer
26	2	Connector Arm	76	2	M10 Jam Nut
27	1	Disc Axle	77	2	Crank Washer
28	1	Small Drive Belt	78	6	M8 Washer
29	2	Crank Arm	79	4	M6 Washer
30	1	Crank	80	2	M5 Nut
31	1	Large Drive Belt	81	2	M10 Shoulder Bolt
32	2	Disc	82	5	M4 x 42mm Screw
33	2	Disc Hub	83	8	Clip
34	1	Sprocket	84	4	M6 x 14mm Screw
35	2	Link Arm	85	4	M5 x 16mm Screw
36	1	Resistance Motor	86	1	M3.5 x 12mm Screw
37	1	Resistance Disc	87	8	M8 x 16mm Screw
38	1	Resistance Arm	88	10	Disc Screw
39	1	Resistance Block	89	2	M10 Locknut
40	1	Power Receptacle/Wire	90	2	M10 x 55mm Hex Bolt
41	1	Small Pulley	91	2	Axle Screw
42	1	Clamp	92	2	Flange
43	3	Key	93	2	Stud
44	2	Magnet Cover	94	2	M10 x 55mm Bolt
45	2	M8 Small Washer	95	2	Adjustment Screw
46	1	Left Wheel Cover	96	2	M8 x 15mm Screw
47	2	Self-aligning Bearing	97	2	M8 Shoulder Screw
48	2	Disc Axle Bushing	98	1	M8 x 30mm Bolt
49	2	Disc Ring	99	3	M8 Locknut
50	1	Left Shield	100	6	M8 x 23mm Screw

Key No.	Qty.	Description	Key No.	Qty.	Description
101	14	M4 x 16mm Flat Head Screw	112	1	M10 Screw
102	8	M8 x 20mm Screw	113	25	M4 x 19mm Screw
103	18	Cap Screw	114	3	M4 x 12mm Screw
104	2	Pulley Magnet	115	1	Main Wire
105	6	M8 x 25mm Screw	116	1	Reed Switch/Wire
106	10	M4 x 16mm Screw	117	2	Crank Cover Disc
107	20	M4 x 22mm Screw	118	1	Power Adapter
108	8	M6 x 12mm Screw	*	–	User's Manual
109	2	M8 x 86mm Screw	*	–	Assembly Tool
110	8	M10 x 20mm Screw	*	–	Grease Packet
111	2	Slant Cap			

Note: Specifications are subject to change without notice. For information about ordering replacement parts, see the back cover of this manual. *These parts are not illustrated.

EXPLODED DRAWING A

Model No. PFEL07920.0 R0920A

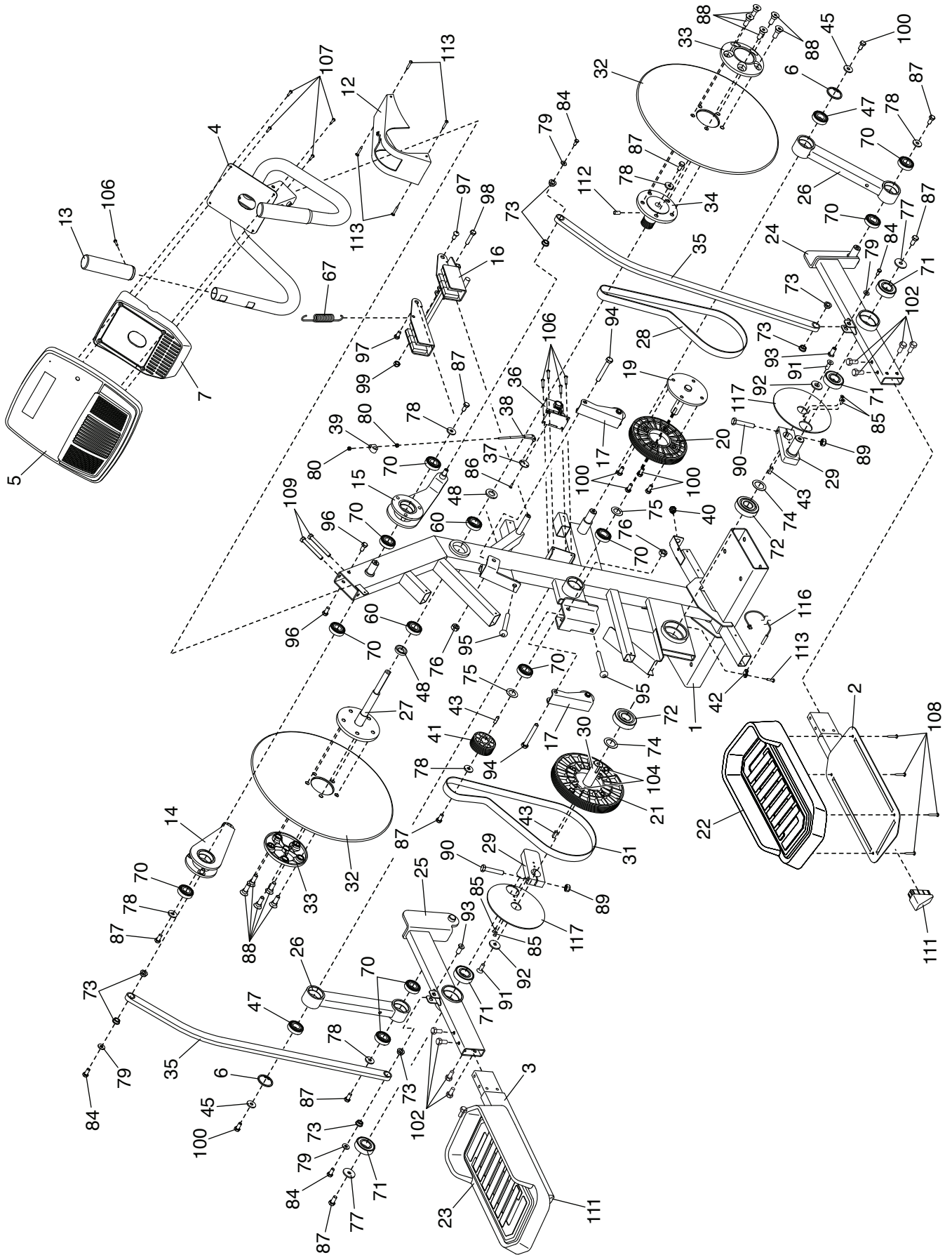

EXPLODED DRAWING B

Model No. PFEL07920.0 R0920A

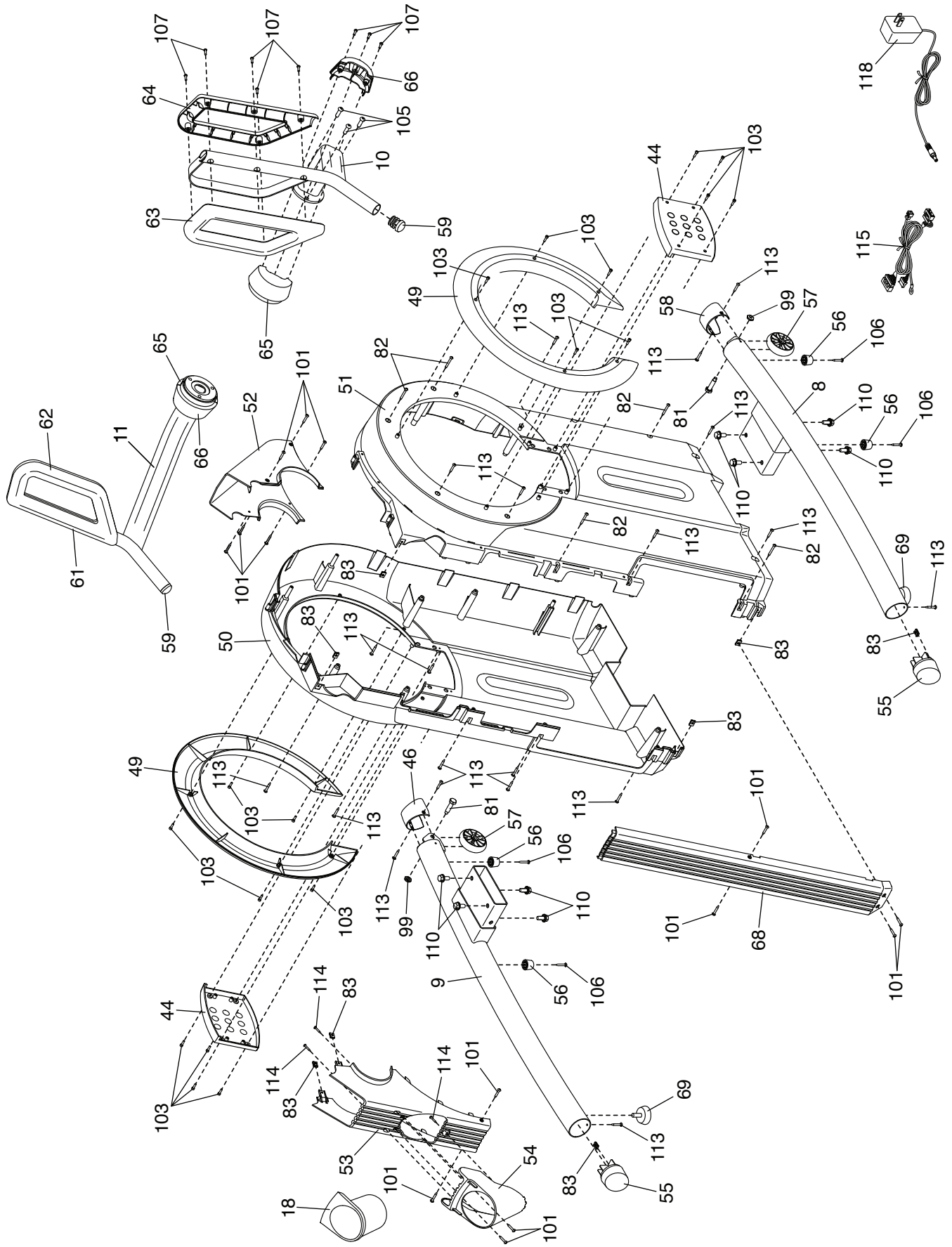

ORDERING REPLACEMENT PARTS

To order replacement parts, please see the front cover of this manual. To help us assist you, be prepared to provide the following information when contacting us:

- the model number and serial number of the product (see the front cover of this manual)
- the name of the product (see the front cover of this manual)
- the key number and description of the replacement part(s) (see the PART LIST and the EXPLODED DRAWING near the end of this manual)

LIMITED WARRANTY

IMPORTANT: To protect your fitness equipment with an extended service plan, see page 4.

ICON Health & Fitness, Inc. (ICON) warrants this product to be free from defects in workmanship and material, under normal use and service conditions. The frame is warranted for ten (10) years from the date of purchase. Parts are warranted for two (2) years from the date of purchase. Labor is warranted for one (1) year from the date of purchase.

This warranty extends only to the original purchaser (customer) and is not transferrable. ICON's obligation under this warranty is limited to repairing or replacing, at ICON's option, the product through one of its authorized service providers. All repairs for which warranty claims are made must be preauthorized by ICON. If replacement parts are shipped while the product is under warranty, the customer will be responsible for a minimal handling charge. For in-home service, the customer may be responsible for a minimal trip charge. This warranty does not extend to freight damage to the product. This warranty will automatically be voided by the following conditions: (1) if the product is used as a store display model, (2) if the product is purchased or transported outside the USA, (3) if all instructions and warnings in this manual are not followed, (4) if the product is abused or improperly or abnormally used, or (5) if the product is used for commercial or rental purposes. No other warranty beyond that specifically set forth above is authorized by ICON.

ICON is not responsible or liable for the following damages: (1) indirect, special, or consequential damages arising out of or in connection with the use or performance of the product; (2) damages with respect to any economic loss, loss of property, loss of revenues or profits, loss of enjoyment or use, or costs of removal or installation; or (3) other consequential damages of any kind. Some states do not allow the exclusion or limitation of incidental or consequential damages. Accordingly, the above limitation may not apply to the customer.

The warranty extended hereunder is in lieu of any and all other warranties, and any implied warranties of merchantability or fitness for a particular purpose are limited in their scope and duration to the terms set forth herein. Some states do not allow limitations on how long an implied warranty lasts. Accordingly, the above limitation may not apply to the customer. This warranty provides specific legal rights; the customer may have other rights that vary from state to state.

For warranty service, please call the telephone number on the front cover of this manual. Please be prepared to provide the model number and serial number of the product (see the front cover of this manual).

ICON Health & Fitness, Inc., 1500 S. 1000 W., Logan, UT 84321-9813