



SHURE

222 HARTREY AVE., EVANSTON, ILL. 60204 U.S.A.

MICROPHONES AND ELECTRONIC COMPONENTS

AREA CODE 312/328-9000 • CABLE: SHUREMICRO

DATA SHEET

MODELS SA-1, SA-1C, SA-2 AND SA-2E SOLO-PHONE® STEREO HEADPHONE AMPLIFIERS

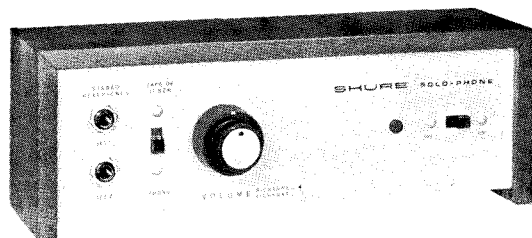

The Shure Solo-Phone Stereo Amplifiers are designed specifically for high fidelity listening with headphones. They provide sufficient amplification and equalization to use any fine quality magnetic phono cartridge (such as the Shure Stereo Dynetic). Additional inputs are available to plug in a multiplex FM tuner or a tape playback unit. Figure A shows a typical arrangement using a turntable with a magnetic cartridge and a tuner or a tape recorder.

Although primarily designed for private high fidelity listening to records, FM, and tape, the Solo-Phones can be used for other applications.

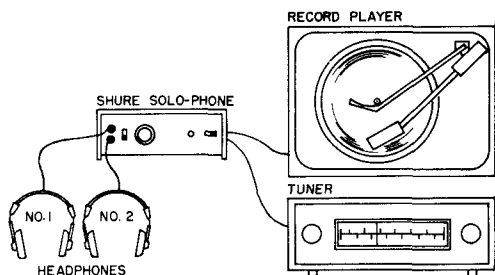

TYPICAL SOLO-PHONE INSTALLATION FIGURE A

- Headphone isolation amplifier (monitoring while tape recording, etc.)
Transcribing disc recordings using tape recorder.
Ceramic microphone amplifier (connect to magnetic cartridge input).
Special installations for the hard-of-hearing.
Ideal for practicing—in private by players and students of electronic organs.
Enables music students and tape recording enthusiasts to monitor tape recordings.

INSTALLATION AND OPERATION

A convenient switch on the front panel permits selection of program sources. Two stereo headphone jacks are provided on the front panel, permitting two sets of stereo headphones to be used at the same time.

An On-Off switch and pilot light are provided on the front panel. The Model SA-1 has a convenient 110 volt AC outlet on the back panel permitting you to plug in the power cord of your record changer, tuner, or tape player.

1. For the Phono position connect the signal leads from the phono cartridge to the jacks on the back panel marked "Magnetic Phono Input."

For the Tuner or Tape position, connect the signal leads from the tuner or tape player to the jacks on the back panel marked "Tape or Tuner Input." Attention must be given to the information in the phono tape, or tuner equipment data sheets regarding their connections for "Right" or "Left" channel, phasing, and grounding. Ground leads from the metal parts of the phono, tape, or tuner equipment, and the external ground may be connected to the screw below the magnetic phono input terminals.

2. Plug the headphones into the jack on the front panel. Set the selector switch to the desired function. (Phono or Tape Tuner).

The volume control is a two-part control allowing separate adjustment of each stereo channel to achieve proper balance between channels. After each channel has been adjusted, simple over-all volume adjustments can be made by turning either part of the dual control.

3. Connect the Solo-Phone power line cord to the proper A.C. power outlet. See Operating Voltage under Specifications. (All Solo-Phones except the SA-2E come with a standard two-conductor AC plug attached.)

The Model SA-2E is supplied with a three-conductor power line cord, but no plug. The power line cord plug should be installed by a qualified person. The brown and blue leads of the power line cord should be connected to the "hot" or line voltage terminals. The green/yellow lead is the grounding conductor and should be connected to the ground or earth terminal of the plug.

If a different power line cord plug is required on the Model SA-2 Solo-Phone, this plug should be installed by qualified service personnel.

In the Models SA-2 and SA-2E either operating voltage is selected by a switch on the back panel. A switch lock plate is provided to prevent accidental switching to the 117-volt position. These Solo-Phones are shipped with operating voltage selector switch locked in the 210-240-volt position. The lock plate can be removed from the locking position by loosening (do not remove) the screw holding the lock plate, rotating the lock plate 90°, and re-tightening the screw.

CAUTION: Do not Plug Power Line Cord of Models SA-2 or SA-2E into 210-240 volts when switched to 117 volts.

ACCESSORY CONNECTING PLUGS

Model PK-1, a package of six connecting plugs, is available. This package contains two phone plugs for connecting headsets and four phono plugs for connecting cables from turntables and tuners to the Solo-Phone.

Guarantee: This Shure product is guaranteed in normal use to be free from electrical and mechanical defects for a period of one year from the date of purchase. Please retain proof of purchase date. This guarantee includes all parts and labor.

Shipping Instructions: Carefully repack the unit and return it prepaid to the factory. If outside the United States, return the unit to your dealer or Authorized Shure Service Center for repair. The unit will be returned to you prepaid.

SPECIFICATIONS

Gain and Frequency Response:

Frequency	Phono Function*	Tape or Tuner Function
100 Hertz	+13 db +3, -2 db re: 1,000 Hertz level	+3, -2 db re: 1,000 Hertz level
1,000 Hertz	34 db ± 3 db 6 mv input produces 300 mv output	7 db ± 3 db 150 mv input produces 340 mv output
10,000 Hertz	-14 db ± 2 db re: 1,000 Hertz level	± 2 db re: 1,000 Hertz level

*Standard RIAA Equalization

Input Impedance:

Phono—47K ohms
Tuner—250K ohms

Range of Load:

The unit shall operate satisfactorily using any earphones with impedances of 4 to 200 ohms. For optimum results, use earphones of 4 to 16 ohm impedance.

Channel Separation:

40 db minimum from 50 to 20,000 Hertz

Total Harmonic Distortion:

Less than 1%—driving both channels simultaneously to 8 ohm resistive load at 100 mv level.

Clipping Level:

400 mv.—at 1,000 Hertz and 8 ohm load.

Operating Voltage:

Model SA-1	117 volts ± 10%	50/60 Hertz
*Model SA-1C	117 volts ± 10%	50/60 Hertz
Models SA-2 and SA-2E	117 volts ± 10%	50/60 Hertz
	210-240 volts	50/60 Hertz

See Paragraph on Installation and Operation.

*Model SA-1C is similar to Model SA-1 except with modifications to meet requirements specified by Canadian Standards Association.

Case Finish:

Satin Walnut.

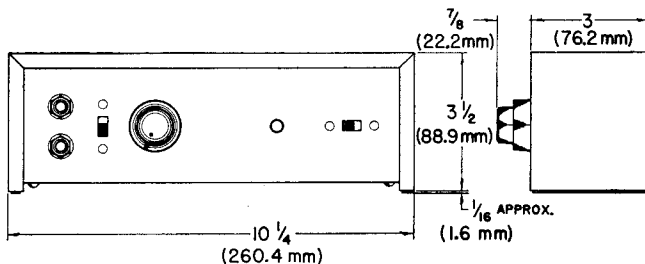

OVERALL DIMENSIONS
FIGURE B

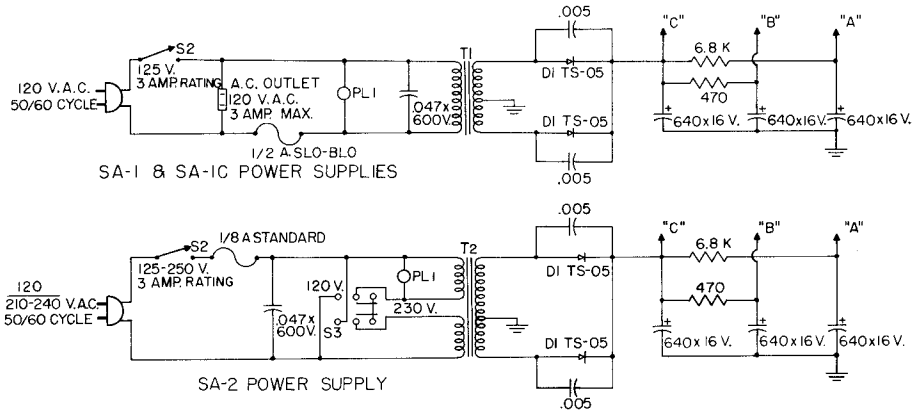
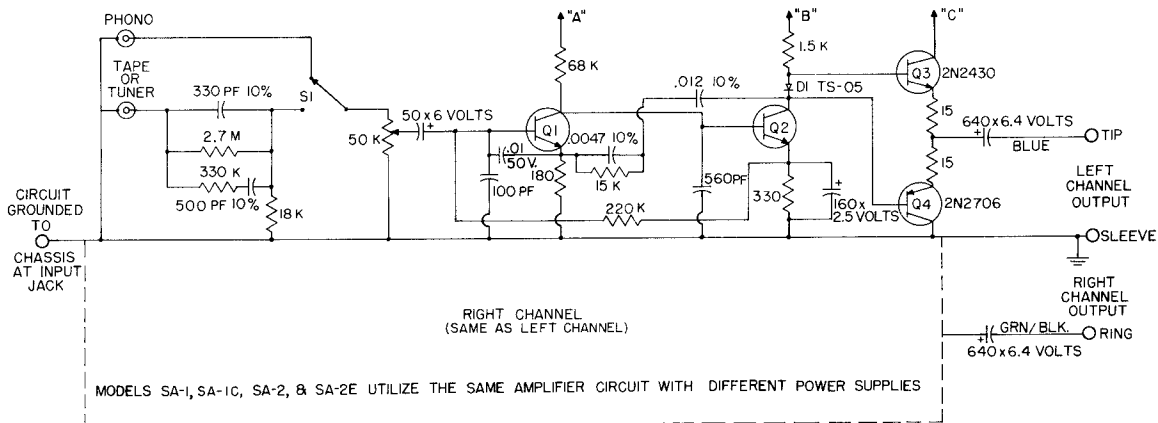

SHURE PART NO./DESCRIPTION		
SE 4002 OR EQUIV.	RKC9	TRANSISTOR Q1 & Q2
2N2430	96A323	Q3
2N2706	86A322	Q4
2N2707	95A180	TRANSISTOR MATCHED SET
DI TS-05	RKC79	DIODE
T1	51A210	TRANSFORMER
T2	51A211	TRANSFORMER

NOTES:
1. ALL CAPACITORS IN MFD UNLESS SHOWN OTHERWISE AND WORKING VOLTAGES OVER 100 UNLESS SHOWN.
2. ALL RESISTORS 1/2 WATT 10%

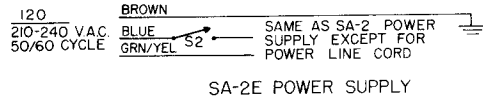

SA-1, SA-1C, SA-2 AND SA-2E SOLO-PHONE CIRCUIT DIAGRAMS