

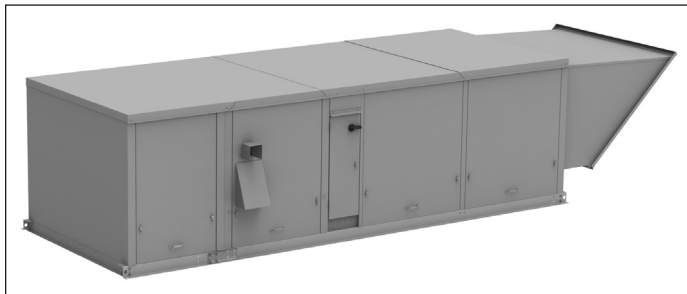

5-572.9
5H0762330001

July, 2016

INSTALLATION AND SERVICE MANUAL gas-fired weatherproof duct furnaces/make-up air units power vented models HBP/HCP/HDP/HPP



Intertek

All models approved for use in California by the CEC.

! WARNING

1. Improper installation, adjustment, alteration, service or maintenance can cause property damage, injury or death, and could cause exposure to substances which have been determined by various state agencies to cause cancer, birth defects or other reproductive harm. Read the installation, operating and maintenance instructions thoroughly before installing or servicing this equipment.
2. Installing, starting up and servicing heating, ventilation and air conditioning equipment poses significant hazards and requires specialized knowledge of Modine products and training in performing those services. Failure to have any service properly performed by, or making any modification to Modine equipment without the use of, qualified service personnel could result in serious injury to person and property, including death. Therefore, only qualified service personnel should work on any Modine products.

! CAUTION

To prevent premature heat exchanger failure do not locate ANY gas-fired units in areas where chlorinated, halogenated, or acid vapors are present in the atmosphere.

FOR YOUR SAFETY

IF YOU SMELL GAS:

1. Open windows.
2. Don't touch electrical switches.
3. Extinguish any open flame.
4. Immediately call your gas supplier.

FOR YOUR SAFETY

The use and storage of gasoline or other flammable vapors and liquids in open containers in the vicinity of this appliance is hazardous.

IMPORTANT

The use of this manual is specifically intended for a qualified installation and service agency. A qualified installation and service agency must perform all installation and service of these appliances.

Inspection on Arrival

1. Inspect unit upon arrival. In case of damage, report it immediately to transportation company and your local factory sales representative.
2. Check rating plate on unit to verify that power supply meets available electric power at the point of installation.
3. Inspect unit upon arrival for conformance with description of product ordered (including specifications where applicable).

SPECIAL PRECAUTIONS / TABLE OF CONTENTS

SPECIAL PRECAUTIONS

THE INSTALLATION AND MAINTENANCE INSTRUCTIONS IN THIS MANUAL MUST BE FOLLOWED TO PROVIDE SAFE, EFFICIENT AND TROUBLE-FREE OPERATION. IN ADDITION, PARTICULAR CARE MUST BE EXERCISED REGARDING THE SPECIAL PRECAUTIONS LISTED BELOW. FAILURE TO PROPERLY ADDRESS THESE CRITICAL AREAS COULD RESULT IN PROPERTY DAMAGE OR LOSS, PERSONAL INJURY, OR DEATH. THESE INSTRUCTIONS ARE SUBJECT TO ANY MORE RESTRICTIVE LOCAL OR NATIONAL CODES.

HAZARD INTENSITY LEVELS

- DANGER:** Indicates an imminently hazardous situation which, if not avoided, WILL result in death or serious injury.
- WARNING:** Indicates a potentially hazardous situation which, if not avoided, COULD result in death or serious injury.
- CAUTION:** Indicates a potentially hazardous situation which, if not avoided, MAY result in minor or moderate injury.
- IMPORTANT:** Indicates a situation which, if not avoided, MAY result in a potential safety concern.

DANGER

Appliances must not be installed where they may be exposed to a potentially explosive or flammable atmosphere.

WARNING

- All field gas piping must be pressure/leak tested prior to operation. Never use an open flame. Use a soap solution or equivalent for testing.
- Gas pressure to appliance controls must never exceed 14" W.C. (1/2 psi).
- Disconnect power supply before making wiring connections to prevent electrical shock and equipment damage.
- All appliances must be wired strictly in accordance with wiring diagram furnished with the appliance. Any wiring different from the wiring diagram could result in a hazard to persons and property.
- Any original factory wiring that requires replacement must be replaced with wiring material having a temperature rating of at least 105°C.
- To reduce the opportunity for condensation, the minimum sea level input to the appliance, as indicated on the serial plate, must not be less than 5% below the rated input, or 5% below the minimum rated input of dual rated units.
- Ensure that the supply voltage to the appliance, as indicated on the serial plate, is not 5% greater than the rated voltage.
- When servicing or repairing this equipment, use only factory-approved service replacement parts. A complete replacement parts list may be obtained by contacting Modine Manufacturing Company. Refer to the rating plate on the appliance for complete appliance model number, serial number, and company address. Any substitution of parts or controls not approved by the factory will be at the owners risk.

CAUTION

- Appliances are designed for outdoor installation only. DO NOT LOCATE APPLIANCES INDOORS.
- Purging of air from gas lines should be performed as described in ANSI Z223.1 - latest edition "National Fuel Gas Code", or in Canada in CAN/CGA-B149 codes.
- Ensure that the supply voltage to the appliance, as indicated on the serial plate, is not 5% less than the rated voltage.
- Do not reuse any mechanical or electrical component which has been wet. Such component must be replaced.

IMPORTANT

- To prevent premature heat exchanger failure, do not locate ANY gas-fired appliances in areas where corrosive vapors (i.e. chlorinated, halogenated or acid) are present in the atmosphere.
- To prevent premature heat exchanger failure, the input to the appliance, as indicated on the serial plate, must not exceed the rated input by more than 5%.
- To prevent premature heat exchanger failure, observe heat exchanger tubes by looking at the heat exchanger through the field installed access openings in connecting ductwork in model HBP or the unit access doors in models HDP, HCP, or HPP. If the bottom of the tubes become red while blower and duct furnace are in operation, check to be sure the blower has been set to the proper rpm for the application. Refer to page 16 for Blower Adjustments.
- Start-up and adjustment procedures should be performed by a qualified service agency.
- To check most of the Possible Remedies in the troubleshooting guide listed in Table 52.1, refer to the applicable sections of the manual.

Table of Contents

Inspection on Arrival.....	1
Special Precautions.....	2
SI (Metric) Conversion Factors	3
Unit Location	3
Combustible Material and Service Clearances	3
Sound and Vibration Levels	4
Rigging Instructions.....	4
Curb or Sub-Base Mounting.....	4
Slab Mounting	4
Duct Installation.....	5
Unit Installation.....	6
Venting.....	6
Gas Connections	8
Considerations for Elevation.....	10
Electrical Connections	11
Evaporative Cooler	11
Cooling Coil Specifications and Installation.....	12
Start-Up Procedure	14
Pilot Burner and Main Burner Adjustment.....	14
Blower Adjustment.....	16
Lubrication Recommendations	16
Damper Linkage Adjustment	16
Control Operating Sequence.....	17
Options	19
General Performance Data	27
Unit Selection	29
Pressure Drop and Blower Performance Data.....	31
Blower Sheave Assembly Data.....	35
Dimensions.....	40
Weights.....	49
Maintenance.....	50
Service & Troubleshooting	52
Model Designations.....	54
Start-Up Checklist	56
Model Nomenclature	57
Commercial Warranty.....	Back Page

SI (METRIC) CONVERSION FACTORS / UNIT LOCATION

SI (METRIC) CONVERSION FACTORS

Table 3.1

To Convert	Multiply By	To Obtain	To Convert	Multiply By	To Obtain
"W.C.	0.24	kPa	CFH	1.699	m ³ /min
psig	6.893	kPa	Btu/ft ³	0.0374	mJ/m ³
°F	(°F-32) x 0.555	°C	pound	0.453	kg
inches	25.4	mm	Btu/hr	0.000293	kW/hr
feet	0.305	meters	gallons	3.785	liters
CFM	0.028	m ³ /min	psig	27.7	"W.C.

UNIT LOCATION

! DANGER

Appliances must not be installed where they may be exposed to potentially explosive or flammable atmosphere.

! CAUTION

Appliances are designed for outdoor installation only. DO NOT LOCATE APPLIANCES INDOORS.

IMPORTANT

To prevent premature heat exchanger failure, do not locate ANY gas-fired appliances in areas where corrosive vapors (i.e. chlorinated, halogenated or acid) are present in the atmosphere.

Location Recommendations

1. When locating the furnace, consider general space and heating requirements and availability of gas and electrical supply.
2. Unit must be installed on the positive pressure side of the circulating blower.
3. Be sure the structural support at the unit location site is adequate to support the weight of the unit and any other required support structure. For proper operation the unit must be installed in a level horizontal position.
4. Do not install units in locations where the flue products can be drawn into the adjacent building openings such as windows, fresh air intakes, etc.
5. Be sure that the minimum clearances to combustible materials and recommended service clearances are maintained. For HBP/HCP/HDP/HPP units, be sure

clearances are maintained to the combustion air inlet louvers and power exhauster discharge cover. Units are designed for installation on non-combustible surfaces or combustible surfaces with the minimum clearances shown in Figure 3.1, Table 3.2, and Table 3.3

6. On units that have fresh air openings, a method should be provided to prevent water and debris from entering the unit such as a rainhood and bird screen, evaporative cooler, etc.
7. On HBP and HCP models, adequate space must be provided to install the discharge duct as shown in Figure 6.1. to insure even air flow across the heat exchanger.

Table 3.2 - Combustible Material Clearances

Model Size	Access Side (A)	Front & Rear (B)	Non-Access Side (C)
75	18"	3"	0"
100/125	20"	3"	0"
150/175	25"	3"	0"
200/225	27"	4"	0"
250/300	30"	5"	0"
350/400	41"	11"	0"
500/600	30"	5"	0"
700/800	41"	11"	0"
840/960	41"	11"	0"

Table 3.3 - Service Clearances

Model Size	Access Side (A)	Non-Access Side (C)
		6"
75	18"	6"
100/125	20"	
150/175	25"	
200/225	27"	
250/300	30"	
350/400	41"	
500/600	30"	
700/800	41"	
840/960	41"	

Figure 3.1 - Combustible Material & Service Clearances ①

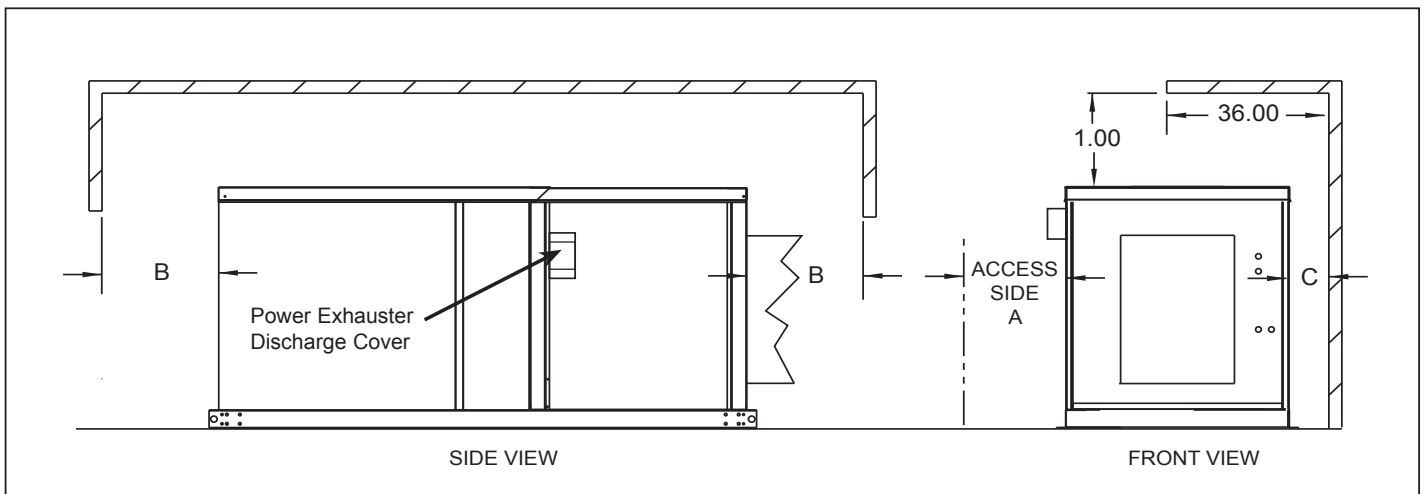

① Minimum clearance to combustible for HBP/HCP/HDP/HPP is 1.0" from rooftop.

UNIT LOCATION/ROOF CURB INSTALLATION

Sound and Vibration Levels

All mechanical equipment generates some sound and vibration that may require attenuation. Libraries, private offices, and hospital patient rooms will require more attenuation and in such cases an acoustical consultant may be retained to assist in the application. Locating the equipment away from the critical area is desirable within ducting limitations. Frequently, units can be located above utility areas, corridors, restrooms, and other non-critical areas. Generally, a unit should be located within 15 feet of a primary support beam. Smaller deflections mean lesser vibration and noise transmission.

Roof curb must be installed level. If roof is pitched it will be necessary to construct a sub-base on which to install the curb.

Install the unit over roof decking with 2" acoustic fiberglass lining within curb area for sound attenuation. The return air duct should be acoustically lined and should be installed with a flexible connection. If the ceiling space is used as a plenum, the acoustically lined return intake duct should form an inverted tee with five foot minimum legs in each direction.

The discharge duct should be acoustically insulated and should have a flexible connection as illustrated.

Figure 4.1 - Suggested Sound Attenuation

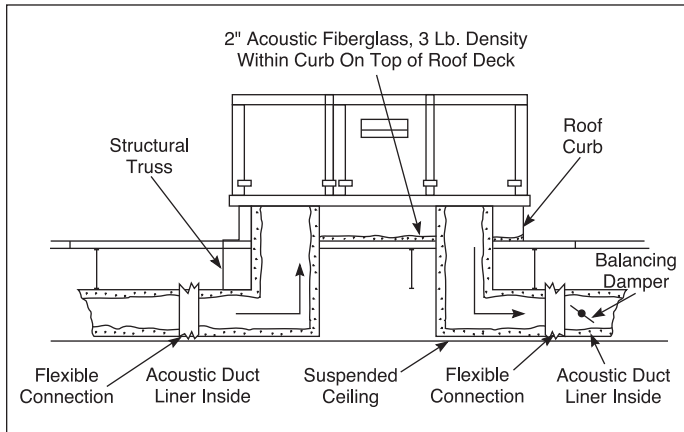

Curb or Sub-Base Mounted Sites

An optional roof curb is available to simplify site preparation and raise the unit above roof water and snow level for drainage. It can be installed with the roof, and in advance of the unit. A sub-base must be furnished by the installer if no curb is supplied for the roof. The sub-base, either steel or concrete, must provide required support with the unit bolted to sub-base. The following are some general guidelines for roof curb installed units:

1. The roof structure must be adequately designed to support the live weight load of the unit and any other required support structure. For the bearing loads normally encountered, the roof curb should be supported at points no greater than five feet apart. Additional truss reinforcement should be provided, if necessary.
2. Roof curbs supplied by Modine are fabricated from 16 gauge galvanized steel and supplied knocked down for assembly on the job site. The curb consists of two side pieces, two end pieces, gasketing, four joiner angles, four 2x4 inch wood nailing strips, nuts, bolts, and washers. Roof curbs over 120 inches long include two additional side pieces and two splice plates. Refer to the latest revision of Modine literature 5-590 for instructions.
3. Outside dimensions must be held when installing curb. Top surface must be level and straight to insure weather-tightness. All corners must be square.
4. All dimensions are +1/8 inch.
5. Final electric and gas connections must be made after unit is installed to allow for tolerance in setting of unit on curb. For electrical power supply allow approximately eight feet of wire, plus provisions for weathertight flexible conduit for connection to unit, as required by local codes.
6. Maintain an 12-inch minimum height from top of roof deck to top of curb.
7. Caulk butt joints after curb is assembled and installed on roof structural members and roof flashing is added.

Figure 4.3 - Typical Curb Details

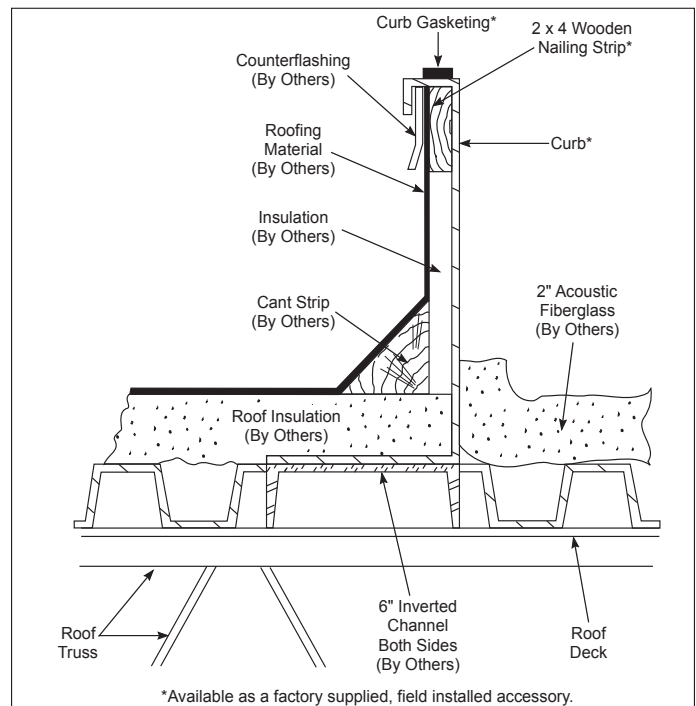

Rigging Instructions

Four 3/4-inch holes at the extended ends of the mounting channels are supplied to facilitate lifting the unit with eyebolts to be furnished by the installer. For either crane or helicopter lift of the equipment to the rooftop, connect sturdy steel cables with eye loops as illustrated in Figure 4.2. To prevent cable from marring the cabinet end tops, use spreader bars or an angle iron frame at least 6" longer and wider than the unit to spread the lifting cables above the unit. For stability in lifting and lowering, include a spreader piece between the two cable spreaders as illustrated in Figure 4.2.

Figure 4.2 - Typical Rooftop Furnace Rigging

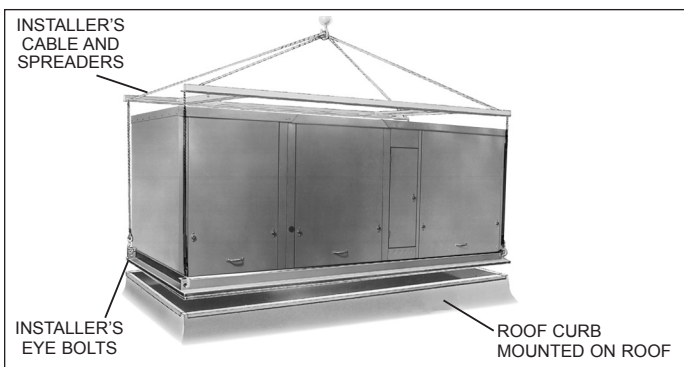

SLAB MOUNT/DUCT INSTALLATION

Slab Mounted Sites — Models HBP & HCP

For ground level installation of a front-discharge unit prepare a level concrete slab at least four inches thick on adequate footings and a generous bed of gravel for drainage (See Figure 5.1). The slab should include threaded 5/8-inch anchor bolts spaced according to Figure 5.2. Anchor bolts should extend at least 1-1/2" above the surface of the floor to allow clearance for mounting washers, nuts and bolts (mounting washers, nuts and bolts by others). The slab should extend out at least six inches around the perimeter of the unit.

Figure 5.1 - Slab-Mounted Furnace

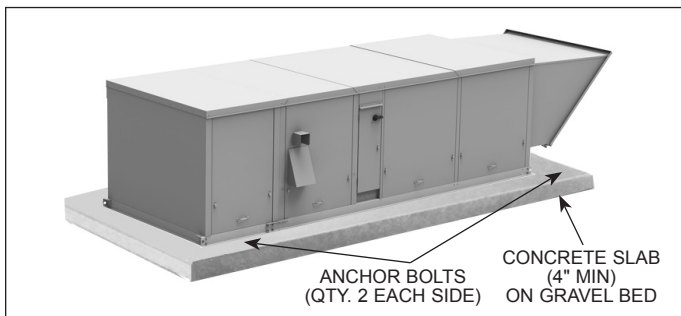
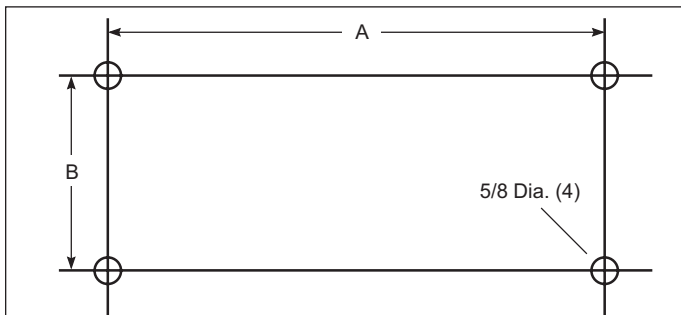

Figure 5.2 - Slab Anchor Bolt Dimensions



Model Size	Blower Type (Digit 16)	A	B
HBP 75	All	82.91	33.85
HBP100/125	All	82.91	36.36
HBP150/175	All	82.91	40.61
HBP200/225	All	82.91	42.71
HBP250/300	E, F, G, or H	82.91	45.75
HBP250/300	I, J, or K	118.50	45.75
HBP350/400	E, F, G, or H	82.91	57.27
HBP350/400	I, J, or K	118.50	57.27
HBP500/600	G or H	116.03	45.75
HBP500/600	I, J, K, or L	151.62	45.75
HBP700/800	G or H	116.03	57.27
HBP700/800	I, J, K, or L	151.62	57.27
HBP840/960	All	185.02	57.27
HCP 75	All	106.89	33.85
HCP100/125	All	106.89	36.36
HCP150/175	All	106.89	40.61
HCP200/225	All	106.89	42.71
HCP250/300	E, F, G, or H	106.89	45.75
HCP250/300	I, J, or K	142.48	45.75
HCP350/400	E, F, G, or H	106.89	57.27
HCP350/400	I, J, or K	142.48	57.27

Duct Installation

For HBP and HCP (Horizontal Discharge):

1. The blower section back and bottom and the furnace discharge are designed to accept 90° flanged ductwork. See Figure 5.3. Provide an airtight seal between the ductwork and the unit. Seams with cracks in the ductwork should be caulked and/or taped and be of permanent type. All duct connections outside the building MUST be weathertight to prevent rain and snow from entering the ductwork.
2. Acoustic duct liners are recommended on all internal return air ducts.

Figure 5.3 - Duct Connections

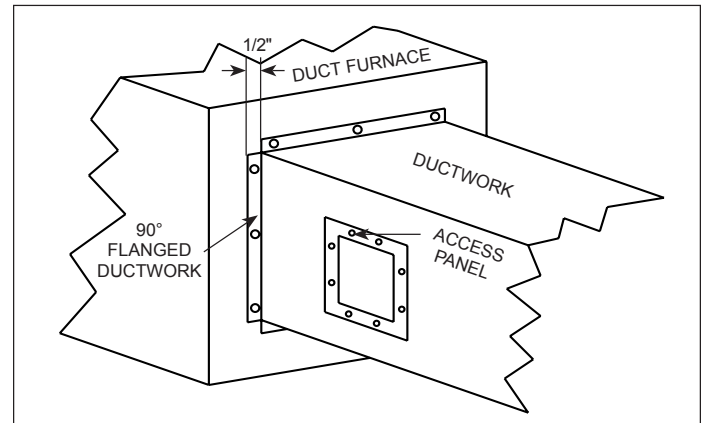

3. When a roof curb is used in conjunction with a factory supplied return air connector, the ductwork can be fastened to the connectors prior to the unit installation. The connectors will accept 90° flanged ductwork. See Figure 6.2.
4. Provide uniform air distribution over the heat exchanger. Use turning vanes where required to obtain uniform air distribution. See Figure 6.1.
5. On model HBP, provide removable access panels on the downstream side of the unit. See Figure 5.3. These openings should be large enough to view smoke or reflect light inside the casing to indicate leaks in the heat exchanger and to check for hot spots on the heat exchanger due to a lack of sufficient air (CFM). Not required on model HCP because the cooling cabinet access door can be removed for this purpose.

DUCT INSTALLATION/RIGGING INSTRUCTIONS/UNIT INSTALLATION

Figure 6.1 - Recommended Field Installed Discharge Duct Configurations for models HBP and HCP

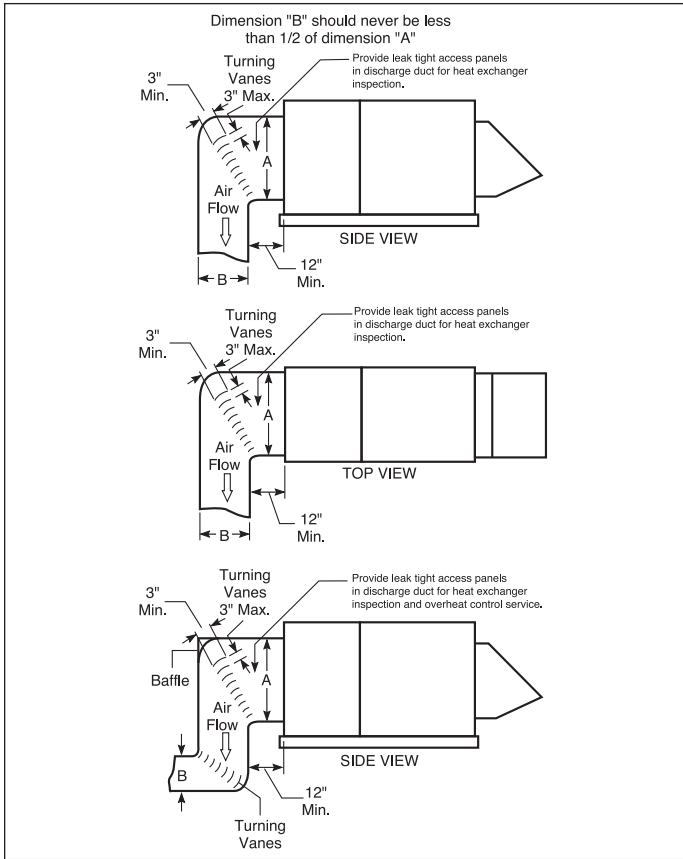

For HDP and HPP (Downturn Discharge):

1. The blower section back and bottom and the downturn plenum bottom is designed to accept 90° flanged ductwork on both the supply and return air openings. Refer to the roof curb (Figure 46.1) or the unit base (Figure 45.1) dimensional drawings to determine the location of the openings.
2. Acoustic duct liners are recommended on all internal supply and return air ducts.
3. When ductwork is installed prior to unit arrival, flexible connections should be included to make connections easier and to simplify possible future service.
4. When a roof curb is used in conjunction with factory supplied discharge and/or return air connectors, the ductwork can be fastened to the connectors prior to the unit installation. The connectors will accept 90° flanged ductwork. See Figure 6.2.

Figure 6.2 - Discharge and/or Return Air Connectors

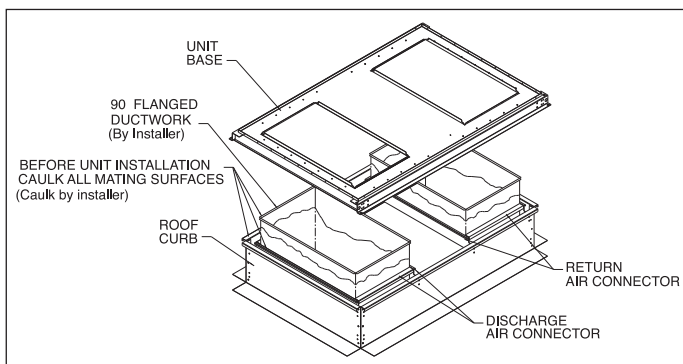

Utility Connections

Utility and control connections can be made to the unit from the bottom for roof curb-mounted units or through the fixed side panels for horizontal supply and return units. Holes can be made in fixed side panels to accommodate utility connections as specified according to the unit dimensional drawings. Sealing of holes cut in the unit casing for utility connections should be done with care to prevent air and water leaks.

Unit Installation

Follow site preparation instructions for applicable curb, sub-base, or slab sites before installation. Check Model Identification Plate of unit with plans to be sure unit is properly located. (See pages 54 and 55). Also inspect damper motors and dampers for proper type (e.g., two-position, modulating, fresh air only, fresh and return air, etc.). Although units may look outwardly similar, their function, capacities, options, and accessories will often vary. Check dimensions.

If unit is to be installed on a factory-supplied curb:

1. Install roof curb using previous roof curb instructions (page 4).
2. Thoroughly clean and dry the top of the curb surface.
3. Lay a bead of weather resistant caulking on top perimeter of roof curb as illustrated in Figure 4.3.
4. Orient hoisted unit to its ductwork and set it down evenly on curb.
5. Make final unit connections to the electric power supply and remote control circuits. Connect the gas lines to the unit heating equipment in accordance with the submittal drawings and architect plans. Caulk all utility line clearance holes on the unit after connections are completed.

If unit is to be installed on a separate sub-base or slab, use steps 4 and 5.

Venting

1. Installation of venting must conform with local building codes, or in the absence of local codes, with the National Fuel Gas Code, ANSI Z223.1 (NFPA 54) - Latest Edition. In Canada, installation must be in accordance with CAN/CGA-B149.1 for natural gas units and CAN/CGA-B149.2 for propane units.
2. Units are shipped with the power exhauster discharge cover factory installed.
3. Do not modify or obstruct the combustion air inlet louvers or the power exhauster discharge cover.
4. Do not add any vents other than those supplied by the manufacturer.

THIS PAGE INTENTIONALLY LEFT BLANK

UNIT INSTALLATION

Gas Connections

⚠ WARNING

1. All field gas piping must be pressure/leak tested prior to operation. Never use an open flame. Use a soap solution or equivalent for testing.
2. Gas pressure to appliance controls must never exceed 14" W.C. (1/2 psi).
3. To reduce the opportunity for condensation, the minimum sea level input to the appliance, as indicated on the serial plate, must not be less than 5% below the rated input, or 5% below the minimum rated input of dual rated units.

⚠ CAUTION

Purging of air from gas supply line should be performed as described in ANSI Z223.1 - latest edition "National Fuel Gas Code", or in Canada in CAN/CGA-B149 codes.

IMPORTANT

To prevent premature heat exchanger failure, the input to the appliance, as indicated on the serial plate, must not exceed the rated input by more than 5%.

1. Installation of piping must conform with local building codes, or in the absence of local codes, with the National Fuel Gas Code, ANSI Z223.1 (NFPA 54) - Latest Edition. In Canada, installation must be in accordance with CAN/CGA-B149.1 for natural gas units and CAN/CGA-B149.2 for propane units.
2. Piping to units should conform with local and national requirements for type and volume of gas handled, and pressure drop allowed in the line. Refer to Table 9.1 to determine the cubic feet per hour (cfh) for the type of gas and size of unit to be installed. Using this cfh value and the length of pipe necessary, determine the pipe diameter from Table 8.1. Where several units are served by the same main, the total capacity, cfh and length of main must be considered. Avoid pipe sizes smaller than 1/2". Table 8.1 allows for a 0.3" W.C. pressure drop in the supply pressure from the building main to the unit. The inlet pressure to the unit must be 6-7" W.C. for natural gas and 11-14" W.C. for propane gas. When sizing the inlet gas pipe diameter, make sure that the unit supply pressure can be met after the 0.3" W.C. has been subtracted. If the 0.3" W.C. pressure drop is too high, refer to the Gas Engineer's Handbook for other gas pipe capacities.
3. The gas piping to the unit can enter the unit from the side of the unit or from below. Install a ground joint union with brass seat and a manual shut-off valve external of the unit casing, and adjacent to the unit for emergency shut-off and easy servicing of controls, including a 1/8" NPT plugged tapping accessible for test gauge connection (See Figure 8.1). Verify the manual shut-off valve is gas tight on an annual basis.
4. Provide a sediment trap before each unit in the line where low spots cannot be avoided. (See Figure 8.1).
5. When Pressure/Leak testing, pressures above 14" W.C. (1/2 psi), close the field installed shut-off valve, disconnect the appliance and its combination gas control from the gas supply line, and plug the supply line before testing. When testing pressures 14" W.C. (1/2 psi) or below, close the manual shut-off valve on the appliance before testing.

Figure 8.1 - Recommended Sediment Trap/Manual Shut-off Valve Installation - Side or Bottom Gas Connection

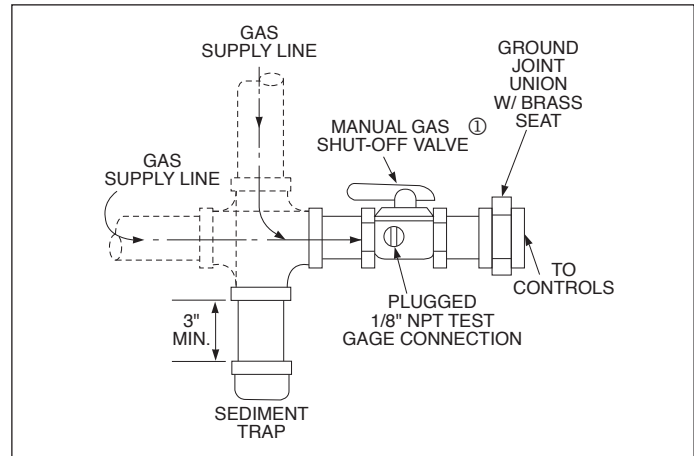

① Manual shut-off valve is in the "OFF" position when handle is perpendicular to pipe.

Table 8.1 - Gas Pipe Capacities - Natural Gas ①②

Pipe Length (ft)	Natural Gas					
	1/2"	3/4"	1"	1-1/4"	1-1/2"	2"
10	132	278	520	1050	1600	3050
20	92	190	350	730	1100	2100
30	73	152	285	590	890	1650
40	63	130	245	500	760	1450
50	56	115	215	440	670	1270
60	50	105	195	400	610	1150
70	46	96	180	370	560	1050
80	43	90	170	350	530	930
100	38	79	150	305	460	870
125	34	72	130	275	410	780
150	31	64	120	250	380	710

① Capacities in Cubic Feet per Hour through Schedule 40 pipe with maximum 0.3" W.C. pressure drop with up to 14" W.C. gas pressure. Specific gravity is 0.60 for Natural gas and 1.50 for Propane gas.

② For Pipe Capacity with Propane Gas, divide Natural gas capacity by 1.6. Example: What is the Propane gas pipe capacity for 60 feet of 1-1/4" pipe? The Natural gas capacity is 400 CFH. Divide by 1.6 to get 250 CFH for Propane gas.

INSTALLATION

Table 9.1 - Burner Orifice Sizing and Gas Consumption

Model Size		Gas Type		Orifice Qty
		Natural ①	Propane ②	
75	Cfh	72.1	30.0	1
	Orifice Drill Size	20	39	
100	Cfh	96.1	40.0	2
	Orifice Drill Size	30	45	
125	Cfh	120.2	50.0	2
	Orifice Drill Size	25	42	
150	Cfh	144.2	60.0	3
	Orifice Drill Size	30	45	
175	Cfh	168.3	70.0	3
	Orifice Drill Size	27	43	
200	Cfh	192.3	80.0	3
	Orifice Drill Size	23	42	
225	Cfh	216.3	90.0	3
	Orifice Drill Size	20	39	
250	Cfh	240.4	100.0	4
	Orifice Drill Size	25	42	
300	Cfh	288.7	120.0	4
	Orifice Drill Size	20	39	
350	Cfh	336.5	140.0	6
	Orifice Drill Size	27	43	
400	Cfh	384.6	160.0	6
	Orifice Drill Size	23	42	
500 ③	Cfh	240.4	100.0	4
	Orifice Drill Size	25	42	
600 ③	Cfh	288.7	120.0	4
	Orifice Drill Size	20	39	
700 ③	Cfh	336.5	140.0	6
	Orifice Drill Size	27	43	
800 ③	Cfh	384.6	160.0	6
	Orifice Drill Size	23	42	
840 ④	Cfh	336.5	140.0	6
	Orifice Drill Size	27	43	
960 ④	Cfh	384.6	160.0	6
	Orifice Drill Size	23	42	

- ① Based on natural gas properties of 1040 Btu/ft³ and specific gravity of 0.60.
- ② Based on propane gas properties of 2500 Btu/ft³ and specific gravity of 1.53.
- ③ Model sizes 500-800 contain 2 furnaces. Values shown are per furnace.
- ④ Model sizes 840-960 contain 3 furnaces. Values shown are per furnace.

INSTALLATION

Considerations for Elevation

The standard ratings for Model HFP (duct furnace portion) are certified for elevations up to 2000 feet above sea level. Operation at elevations above 2,000 feet requires ratings be reduced 4% for each 1000 feet above sea level per ANSI Z223.1. The exception is for units in Canada, CSA requires that ratings be reduced 10% for elevations between 2,001 and 4500 feet. The following instructions are for units that will be installed over 2,000 feet elevation. If this does not apply, you may skip ahead to the Electrical Connections section on page 11.

Manifold Pressure Adjustment

The unit manifold pressure is factory set for operation at elevations up to 2000 feet as follows:

- For **Natural Gas** units, 3.5" W.C. based on a gas heating value of 1,050 BTU/ft³.
- For **Propane Gas** units, 10.0" W.C. based on a gas heating value of 2,500 BTU/ft³.

For higher elevations, some utility companies may derate the BTU content (heating value) of the gas provided at altitude to a lower value to allow certain heating appliances to be used with no manifold pressure adjustments. For this reason it is necessary that the supplying utility be contacted for detailed information about the gas type and BTU content (heating value) before operating any heater. Table 10.1 shows the standard derated heating values of natural and propane gases at various elevations.

Table 10.1
Gas Heating Values at Altitude (Btu/ft³) ①②③⑤

Altitude (ft)	Natural Gas	Propane
0-2,000	1,050	2,500
2,001-3,000	929 ③	2,212 ④
3,001-4,000	892 ③	2,123 ④
4,001-4,500	874 ③	2,080 ④
4,501-5,000	856	2,038
5,001-6,000	822	1,957
6,001-7,000	789	1,879
7,001-8,000	757	1,803
8,001-9,000	727	1,731
9,001-10,000	698	1,662

- ① Values shown are for 3.5" W.C. manifold pressure for Natural Gas and 10.0" W.C. for Propane Gas. If the local utility supplies gas with a different Btu/ft³ value, use Equation 10.1 to calculate the required manifold pressure.
- ② Gas heating values shown are derated 4% per 1,000' of elevation (10% between 2,000' and 4,500' elevation in Canada) in accordance with ANSI Z223.1 and CSA-B149, respectively.
- ③ 945 Btu/ft³ for Canada
- ④ 2,250 Btu/ft³ for Canada
- ⑤ When installed at altitudes above 2,000', a pressure switch may need to be changed. Refer to Tables 10.2 and 10.3 to determine if a switch change is required.

If the utility is supplying gas with heating values **SAME** as shown in Table 10.1, the manifold pressure should remain set to 3.5" W.C. for natural gas and 10.0" W.C. for propane gas and you may proceed to the section on this page titled "Selection of the Proper High Altitude Kit".

If the utility is supplying gas with heating values **DIFFERENT** than shown in Table 10.1, use Equation 10.1 to determine the appropriate manifold pressure for the elevation and gas heating value being supplied. Note what that value is, as it will be needed later for Start-Up. Proceed to the section on this page titled "Selection of the Proper High Altitude Kit".

Equation 10.1 - Manifold Pressure for Gas Heating Values Different Than Shown in Table 10.1

$$MP_{ELEV} = \left(\frac{BTU_{TBL}}{BTU_{ACT}} \right)^2 \times MP_{SL}$$

Where:

MP_{ELEV} = Manifold Pressure (" W.C.) at installed elevation

BTU_{TBL} = BTU/ft³ content of gas from Table 10.1

BTU_{ACT} = BTU/ft³ content of gas obtained from the utility company

MP_{SL} = Manifold Pressure (" W.C.), at Sea Level (use 3.5" W.C. for natural gas and 10.0" W.C. for propane)

NOTE: For units equipped with two-stage or modulating gas controls, only the high fire manifold pressure needs to be adjusted. No adjustments to the low fire manifold pressure are necessary on these units.

Selection of the Proper High Altitude Kit

All units installed at elevations greater than 2000 feet above sea level require a kit, in addition to potential manifold pressure adjustment outlined in the previous step. To determine the proper kit to use, refer to Table 10.2.

Table 10.3 shows the contents of the kit. For more information, refer to the latest revision of Modine Bulletin 75-530.

Table 10.2 - High Altitude Kit Selection Table ①②③

Model	Model Size	Elevation Above Sea Level (ft)	Elevation Above Sea Level (ft)		
			2,001-5,500	5,501-6,500	6,501-7,500
All	All	Item Code	67248	67248	67248

- ① Applies to both installations in the U.S. and Canada.
- ② Applies to both natural and propane gas.
- ③ Sizes 75-400 require a kit qty. of 1, sizes 500-800 require a kit qty of 2, sizes 840-960 require a kit qty of 3.

Table 10.3 - High Altitude Kit Contents

Item Code	Kit Contents		
	High Altitude Conversion Label	Pressure Switch	Installation Instructions
67248	Yes	No	Yes

If a unit is to be installed at higher elevations AND converted from natural gas to propane gas operation, a propane conversion kit must be used in conjunction with the manifold pressure adjustment and high altitude kit listed above. For the Selection and Installation Instructions for propane conversion kits, please see the latest revision of Modine Bulletin 75-511.

UNIT INSTALLATION

Electrical Connections

WARNING

1. Disconnect power supply before making wiring connections to prevent electrical shock and equipment damage.
2. All appliances must be wired strictly in accordance with wiring diagram furnished with the appliance. Any wiring different from the wiring diagram could result in a hazard to persons and property.
3. Any original factory wiring that requires replacement must be replaced with wiring material having a temperature rating of at least 105°C.
4. Ensure that the supply voltage to the appliance, as indicated on the serial plate, is not 5% greater than rated voltage.

CAUTION

1. Ensure that the supply voltage to the appliance, as indicated on the serial plate, is not 5% less than the rated voltage.
1. Installation of wiring must conform with local building codes, or in the absence of local codes, with the National Electric Code ANSI/NFPA 70 - Latest Edition. Unit must be electrically grounded in conformance to this code. In Canada, wiring must comply with CSA C22.1, Part 1, Electrical Code.
2. Two copies of the job specific wiring diagram are provided with each unit, one located in the duct furnace electrical junction box and one in the electrical section of the unit. Refer to this diagram for all wiring connections.
3. The wire gauge must be sized according to the National Electric Code or CSA code based on the power supply voltage, amp draw, and length of run. Refer to Table 11.1 for maximum wire lengths and the number of wires that can be wired to each low voltage terminal block.

Table 11.1 - Low Voltage (24V) Maximum Wire Length (ft)

NEC-1996, Table 310-17, Copper wire with 90°C insulation, conductors in free space (not in conduit), 86°F ambient. For other wire types, refer to the NEC of CSA code.

Digit 15	Transformer Size (VA)	Wire Gauge				
		18 Ga	16 Ga	14 Ga	12 Ga	10 Ga
1	40	162	216	315	360	495
2	75	86	115	168	192	264
3	150	43	58	84	96	132
4	250	26	35	50	58	79
Maximum # of Wires per Terminal		5	4	3	2	1

4. Make sure all multi-voltage components (motors, transformers, etc.) are wired in accordance with the power supply voltage.
5. The power supply to the unit must be protected with a fused or circuit breaker disconnect switch. Refer to the Factory Mounted Option Locations (Figure 19.1) for the factory mounted disconnect switch location and then review the unit to determine if a factory installed dead front disconnect switch was provided. Accessory field installed disconnect switches should be mounted where shown in Figure 11.2. For fusible disconnect switches, refer to the Model Identification plate for the fuse size and type.

6. The power supply must be within 5% percent of the voltage rating and each phase must be balanced within 2 percent of each other. If not, advise the utility company.
7. External electrical service connections that must be installed include:
 - a. Supply power (120, 208, 240, 480, or 600 volts).
 - b. Thermostats, remote monitoring panels, building pressure sensors, time clocks, or any other accessory control devices that may be supplied (24 volts).
8. All outdoor electrical connections must be weatherized to prevent moisture from entering the electrical compartment.
9. Refer to the unit dimensional drawings on pages 40 through 44 for the location of the drill locator dimples in the side and bottom of the unit for field drilling the hole for the electrical conduit entry.
10. All supply power electrical connections are made in the electrical section of the unit. The low voltage (thermostat and accessory control devices) can be wired to either the electrical section or the duct furnace electrical junction box. Refer to the wiring diagram for the terminal location of all low voltage wiring.

Figure 11.2 - Recommended Accessory Field Installed Disconnect Switch Mounting Locations

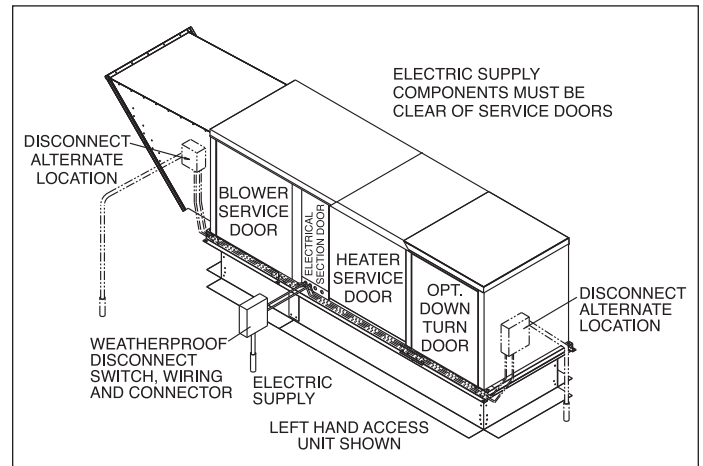

Evaporative Cooler Installation

For units equipped with an evaporative cooler (Digit 22 = B or D), refer to Installation and Service Manual - Evaporative Coolers (Literature 5-588).

UNIT INSTALLATION

Cooling Coil Units

Models with a cooling section can be provided with either a factory installed direct expansion (DX) evaporator, a chilled fluid (for use with water, ethylene glycol, or propylene glycol fluids) coil, or the coil can be field supplied and installed by others. For units equipped with a factory installed cooling coil (Digit 23 = 1), refer to the packing slip to determine the coil type provided.

The cooling section includes a full coverage, 3-way sloping 409 stainless steel drain pan to remove condensate from coil headers, thermal expansion valves, and refrigerant piping. Insulation is standard on outdoor units and optional on indoor units. The cabinet includes two doors, a removable upper door for service access to the coil once the plumbing has been installed and a lower door which includes a factory supplied 1" stubbed drain connection to the exterior of the cabinet. Field connections for coil inlet and outlet piping can be made through the cabinet corner post or back of the unit. The cooling section duct transition includes 1-1/2" flanges for fastening the sides of the coil. The bottom duct transition is angled to remove any condensation that may be entrained in the supply air stream. For field supplied coils, do not exceed the maximum coil dimensions listed in Literature 82-135. The dimensions listed are for the maximum coil dimensions. If the coil supplied is smaller than the listed dimensions, field supplied blank off plates are required to prevent air bypass around the coil. The coil is supported by two 14 gauge support rails which contain mounting provisions for fastening 4", 5", 6", 7.5", 8.5", and 10" deep coils.

Figure 12.1 - Cooling Section

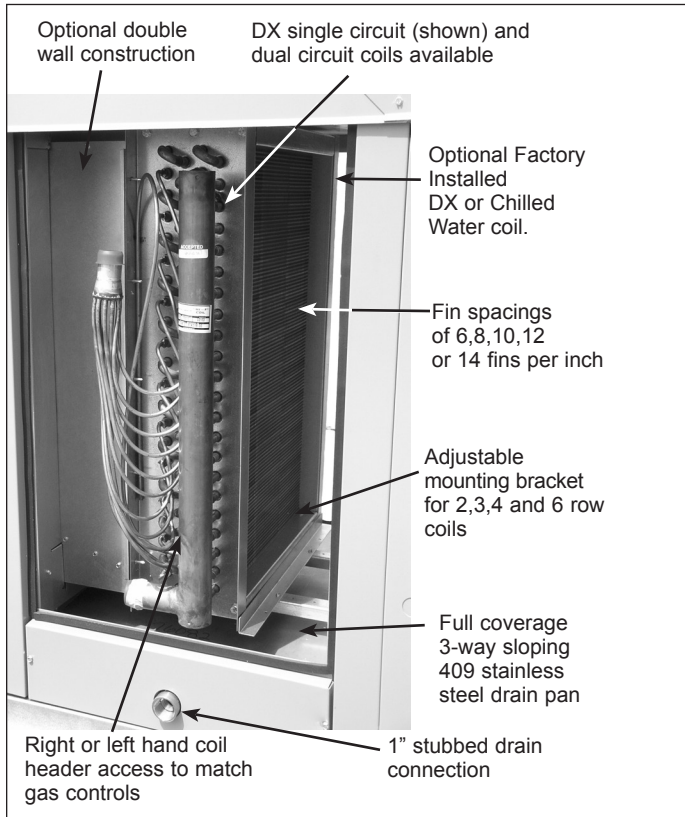

Condensate Drain Pan Trap

The condensate drain line needs to include a P-trap immediately downstream of the connection to the unit. This trap should extend at least two inches below the connection to prevent air pressure from forcing air into the unit. The trap should be primed with a water/glycol solution to prevent freezing.

Direct Expansion (DX) Piping

The refrigerant lines should be insulated to prevent warming or cooling of the refrigerant. If the suction line is allowed to be cooled, liquid will condense in the line and can severely damage the compressor. If the liquid line is warmed, the refrigerant can "flash" into a gas. This will cause erratic operation of the expansion device and impair the heat transfer ability of the cooling coil. Long runs of piping need to be periodically supported to prevent excess vibration that can damage the piping and joints. It is recommended to provide dampening supports at intervals of length equivalent to 15 tube diameters.

Figure 12.2 - General DX Piping

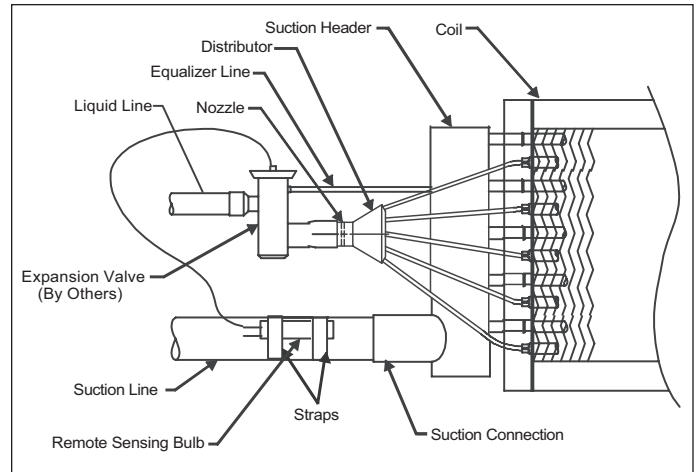

1. Inspect the refrigerant distributor and verify that the nozzle is in place.
2. All field brazing and welding should be performed using high quality materials and an inert gas purge (such as nitrogen) to reduce oxidation of the internal surface of the coil.
3. For DX coils, the use of filter-driers in the system piping is recommended along with a sight glass that has a moisture indicator.
4. Connect the suction line and suction connection.
5. Install the expansion valve (By Others). Follow the expansion valve manufacturer's recommendations for installation to avoid damaging the valve.
6. Connect the liquid line to the expansion valve. Pressurize the coil, expansion valve assembly and suction connection to 100 psig with dry nitrogen or other suitable gas. The coil should be left pressurized for a minimum of 10 minutes.
7. If the coil holds pressure, the installation can be considered leak free. If the pressure drops by 5 psi or less, repressurize the coil and wait another 10 minutes. If the pressure drops again, there are more than likely one or more small leaks, which should be located and repaired. Pressure losses greater than 5 psi would indicate a larger leak, which should be isolated and repaired. Be sure to check valves and fittings as potential sites for leakage or bleed.
8. Use a vacuum pump to evacuate the coil and any interconnecting piping that has been open to atmosphere. Measure the vacuum in the piping using a micron gauge located as far from the pump as possible (the vacuum at the pump will be greater than the rest of the system). Evacuate the coil to 500 microns or less then close the valve between the pump and the system. If the vacuum holds to 500 microns or less for one minute, the system is ready to be charged or refrigerant pumped down in another portion of the system can be opened to the coil. A steady rise in microns would indicate that moisture is still present and that the coil should be further vacuumed until the moisture has been removed.

UNIT INSTALLATION

9. Failure to obtain a high vacuum is indicative of a great deal of moisture or a small leak. Break the vacuum with a charge of dry nitrogen or other suitable gas and recheck for leaks (soapy water works well). If no leaks are found, continue vacuuming the coil until the desired vacuum is reached.
10. All field piping must be self-supporting.

Chilled Fluid Piping

To prevent noise and coil damage from water hammer, an air vent is necessary to bleed off the accumulated air in the system. The vent should be located on the top of the inlet manifold where the air collects. This vent should be opened twice a year.

The outlet manifold should have a drain installed on the bottom to allow for periodic flushing of the system to remove sediments and corrosion products from the cooling coil. This drain should be opened to allow some fluid to drain twice a year. Check coloration and viscosity of the effluent for indications of corrosion in the system. The lines between the unit and the structure should be insulated to prevent freezing of the water.

1. Once installed, the coil should be pressurized to 100 psig with dry nitrogen or other suitable gas. The coil should be left pressurized for a minimum of 10 minutes. If the coil holds the pressure, the hook-up can be considered leak free. If the pressure drops by 5 psig or less re-pressurize the coil and wait another 10 minutes. If the pressure drops again, there is more than likely one or more small leaks which should be located and repaired. Pressure losses greater than 5 psig would indicate a larger leak that should be isolated and repaired.
2. All field brazing and welding should be performed using high quality materials and an inert gas purge (such as nitrogen) to reduce oxidation of the internal surface of the coil.
3. All field piping must be self supporting. System piping should be flexible enough to allow for thermal expansion and contraction of the coil.
4. Fill the coil with water with all air vents open so that air is eliminated from within the coil circuitry and headers. Verify that all vents and drains are not obstructed and do discharge a stream of water.
5. Close all vents and perform a hydrostatic leak test of all brazed, threaded or flanged joints, valves and interconnecting piping. Recheck the coil level and correct if necessary. When the setup is found to be leak free, discharge and discard initial water charge. It is important that all grease, oil, flux and sealing compounds present from the installation be removed.

Figure 13.1 - General Chilled Fluid Piping

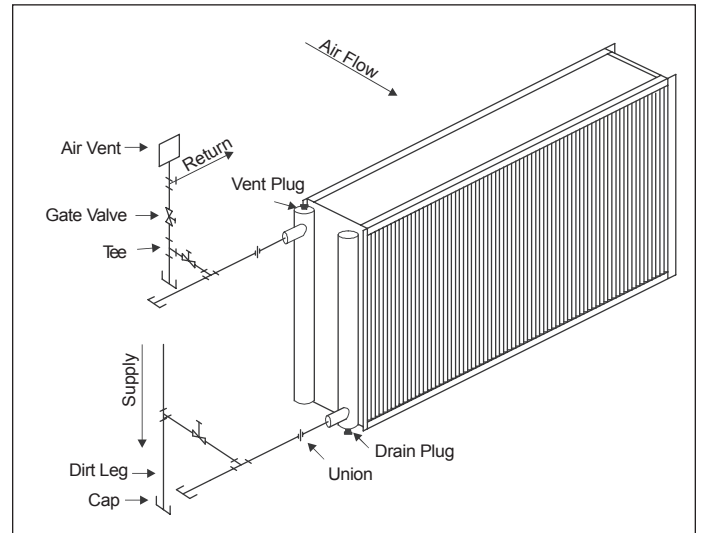

Table 13.1 - Cooling Coil Performance Limits

Cooling Type	Model Size	Min CFM	Single Circuit		Dual Circuit		Max Cooling (Tons) ②
			Max CFM ①	Area (ft ²)	Max CFM ①	Area (ft ²)	
DX	75	688 ③	1,891	3.44	1,707	3.10	9.4
	100	802 ④	2,206	4.01	2,048	3.72	11.4
	125	926					
	150	1,111	2,521	4.58	2,416	4.39	13.4
	175	1,296	3,352	6.09	3,165	5.76	18.1
	200	1,481					
	225	1,667					
	250	1,852	3,724	6.77	3,538	6.43	20.2
	300	2,222	5,214	9.48	4,996	9.08	27.3
	350	2,593					
400	2,963						
Chilled Water	75	609	1,676	3.05	n/a	n/a	10.6
	100	741	2,011	3.66	n/a	n/a	12.6
	125	926					
	150	1,111	2,372	4.31	n/a	n/a	14.8
	175	1,296	3,214	5.84	n/a	n/a	19.3
	200	1,481					
	225	1,667					
	250	1,852	3,592	6.53	n/a	n/a	21.3
	300	2,222	5,073	9.22	n/a	n/a	29.3
	350	2,593					
400	2,963						

① Based on 550 feet per minute (FPM) coil face velocity.
 ② Based on 95°F/75°F Entering Dry Bulb/Wet Bulb.
 ③ Model Size 75 minimum CFM for DX Dual Circuit is 621.
 ④ Model Size 100 minimum CFM for DX Dual Circuit is 745.

START-UP PROCEDURE

Start-Up Procedure

IMPORTANT

1. To prevent premature heat exchanger failure, observe heat exchanger tubes by looking at the heat exchanger through the field installed access openings in connecting ductwork in blower package units or the unit access doors in cooling package units. If the bottom of the tubes become red while blower and duct furnace are in operation, check to be sure the blower has been set to the proper rpm for the application. Refer to page 16 for Blower Adjustments.
 2. Start-up and adjustment procedures should be performed by a qualified service agency.
1. Turn off power to the unit at the disconnect switch. Check that fuses or circuit breakers are in place and sized correctly. Turn all hand gas valves to the "OFF" position.
 2. Remove the blower exterior panels and open the electrical compartment door.
 3. Check that the supply voltage matches the unit supply voltage listed on the Model Identification plate. Verify that all wiring is secure and properly protected. Trace circuits to insure that the unit has been wired according to the wiring diagram.
 4. Check to insure that the venting system is installed and free from obstructions.
 5. Check to see that there are no obstructions to the intake and discharge of the unit.
 6. Check the belt tension and sheave alignment. Refer to Blower Adjustments for proper belt tension.
 7. Check bearings for proper lubrication. For units provided with pillow block bearings (See Model Nomenclature), refer to Lubrication Recommendations for lubrication requirements.
 8. Check to make sure that all filters are in place and that they are installed properly according to direction of air flow.
 9. Perform a visual inspection of the unit to make sure no damage has occurred during installation.
 10. Turn on power to the unit at the disconnect switch. Check to insure that the voltage between duct furnace electrical box terminals 1 and 2 is 24V.
 11. Check the thermostat, ignition control, gas valve, and supply fan blower motor for electrical operation. If these do not function, recheck the wiring diagram. Check to insure that none of the Control Options have tripped.
 12. For units with a return air damper, the return air damper linkage needs to be adjusted. Refer to Damper Linkage Adjustment.
 13. Check to make sure that the damper opens properly without binding.
 14. Check the blower wheel for proper direction of rotation when compared to the air flow direction arrow on the blower housing. Blower wheel rotation, not air movement, must be checked as some air will be delivered through the duct furnace with the blower wheel running backwards.
 15. Check the blower speed (rpm). Refer to Blower Adjustments for modification.
 16. Check the motor speed (rpm).
 17. Check the motor voltage. On three phase systems, check to make sure all legs are in balance.
 18. Check the motor amp draw to make sure it does not exceed the motor nameplate rating. On three phase systems, check all legs to insure system is balanced.

19. Recheck the gas supply pressure at the field installed manual shut-off valve. The minimum inlet pressure should be 6" W.C. on natural gas and 11" W.C. on propane gas. The maximum inlet pressure for either gas is 14" W.C. If inlet pressure exceeds 14" W.C., a gas pressure regulator must be added upstream of the combination gas valve.
20. Open the field installed manual gas shut-off valve.
21. Open the manual main gas valve on the combination gas valve. Call for heat with the thermostat and allow the pilot to light for intermittent pilot ignition. If the pilot does not light, purge the pilot line. If air purging is required, disconnect the pilot line at outlet of pilot valve. In no case should line be purged into heat exchanger. Check the pilot flame length (See Pilot Flame Adjustment).
22. Once the pilot has been established, check to make sure that the main gas valve opens. Check the manifold gas pressure (See Main Gas Adjustment) and flame length (See Air Shutter Adjustment) while the supply fan blower is operating.
23. Check to insure that gas controls sequence properly (See Control Operating Sequence). Verify if the unit has any additional control devices and set according to the instructions in the Control Options.
24. Once proper operation of the unit has been verified, remove any jumper wires that were required for testing.
25. Close the electrical compartment door.
26. Replace all exterior panels.

Refer to page 56 for the Start-up Checklist.

Pilot Burner Adjustment

The pilot burner is orificed to burn properly with an inlet pressure of 6-7" W.C. on natural gas and 11-14" W.C. on propane gas, but final adjustment must be made after installation. If the pilot flame is too long or large, it is possible that it may cause soot and/or impinge on the heat exchanger causing failure. If the pilot flame is shorter than shown, it may cause poor ignition and result in the controls not opening the combination gas control. A short flame can be caused by a dirty pilot orifice. Pilot flame condition should be observed periodically to assure trouble-free operation.

To Adjust the Pilot Flame

1. Create a call for heat from the thermostat.
2. Remove the cap from the pilot adjustment screw. For location, see the combination gas control literature supplied with unit.
3. Adjust the pilot length by turning the screw in or out to achieve a soft steady flame 3/4" to 1" long and encompassing 3/8"-1/2" of the tip of the thermocouple or flame sensing rod (See Figure 14.1).
4. Replace the cap from the pilot adjustment screw.

Figure 14.1 - Correct Pilot Flame

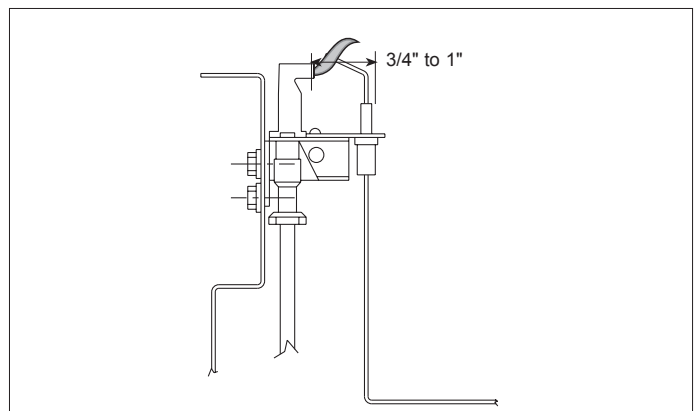

START-UP PROCEDURE

Main Burner Adjustment

The gas pressure regulator (integral to the combination gas control) is adjusted at the factory for average gas conditions. It is important that gas be supplied to the duct furnace in accordance with the input rating on the serial plate. Actual input should be checked and necessary adjustments made after the duct furnace is installed. Over-firing, a result of too high an input, reduces the life of the appliance and increases maintenance. Under no circumstances should the input exceed that shown on the serial plate.

Measuring the manifold pressure is done at the tee in the manifold or at the pressure tap of the gas valve for standard gas string. (See Figure 15.1).

To Adjust the Manifold Pressure

1. Move the field installed manual shut-off valve to the "OFF" position.
2. Remove the 1/8" pipe plug in the pipe tee or gas valve and attach a water manometer of "U" tube type which is at least 12" high.
3. Move the field installed manual gas shut-off valve to the "ON" position.
4. Create a high fire call for heat from the thermostat.
5. Determine the correct high fire manifold pressure. For natural gas 3.5" W.C., for propane gas 10" W.C. Adjust the main gas pressure regulator spring to achieve the proper manifold pressure (for location, see the combination gas control literature supplied with unit).
6. If the unit has Electronic Modulation gas controls (determine from the Model Identification Digit 12), the low fire gas pressure needs to be adjusted. Using Figure 15.2 for item number locations, this is accomplished as follows:
 - a. Disconnect power.
 - b. Remove all wires from Maxitrol Amplifier terminal "3" or duct furnace terminal "43" (if available).
 - c. Turn on power at the disconnect switch.
 - d. Remove the maximum adjustment screw (4), spring (5), and plunger (8). A small magnet is useful for this purpose. CAUTION - The plunger is a precision part. Handle carefully to avoid marring or picking up grease and dirt. Do not lubricate.
 - e. Using minimum adjusting screw (9), adjust low fire manifold pressure to 0.56" W.C. for natural gas and 1.6" W.C. for propane gas.
 - f. Replace plunger and spring retainer, spring, and maximum adjusting screw in proper order.
 - g. Using maximum adjustment screw (4), adjust high fire manifold pressure to 3.5" W.C. for natural gas and 10" W.C. for propane gas.
 - h. Disconnect power.
 - i. Replace cover plate (2) and re-install all wires from Maxitrol amplifier terminal "3" or duct furnace terminal "43".
7. After adjustment, move the field installed manual shut-off valve to the "OFF" position and replace the 1/8" pipe plug.
8. After the plug is in place, move the field installed manual shut-off valve to the "ON" position and recheck pipe plugs for gas leaks with soap solution.

Figure 15.1 - Checking Manifold Pressure with "U" Tube Manometer



Figure 15.2 - Maxitrol Modulating Valve Adjustments

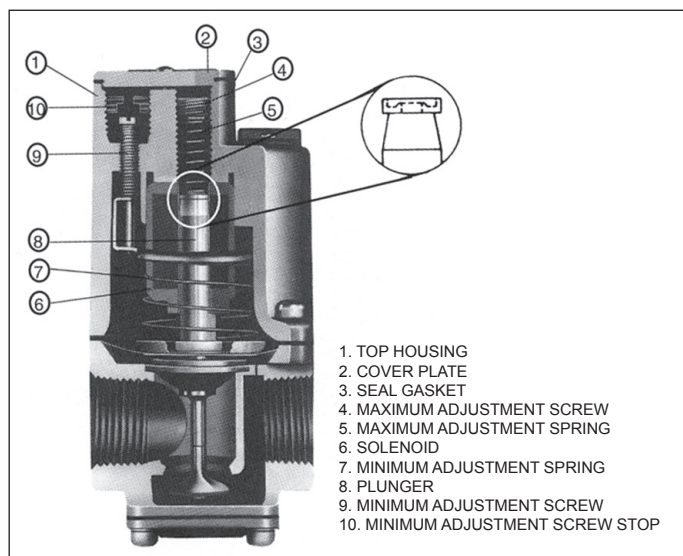

Air Shutter Adjustment

Proper operation provides a soft blue flame with a well-defined inner core. A lack of primary air will reveal soft yellow-tipped flames. Excess primary air produces short, well-defined flames with a tendency to lift off the burner ports. For both natural and propane gas, the air shutters can be adjusted to control the burner flame height. The air shutters can be accessed by reaching behind the manifold tee in Figure 15.1. The larger models may require the removal of the manifold (see Manifold Assembly Removal).

Adjusting the primary combustion air is achieved by resetting the primary air shutters (See Figure 51.2). Prior to flame adjustment, operate duct furnace for about fifteen minutes. The main burner flame can be viewed after loosening and pushing aside the gas designation disc on the side of the burner box.

1. To increase primary air, loosen the air shutter set screws and move the air shutters closer to the manifold until the yellow tipped flames disappear and a clean blue flame with a well defined inner cone appears.
2. To decrease primary air, move the air shutters away from the manifolds until flames no longer lift from burner ports, but being careful not to cause yellow tipping.
3. Re-tighten set screws after adjustment.

START-UP PROCEDURE

Blower Adjustments

If blower fan speed changes are required, adjust motor sheave as follows:

1. Refer to page 32 to determine correct blower speed according to job requirements, then proceed with steps 2 through 8.
2. Loosen motor base and take belt off of motor sheave.
3. Loosen set screw on outer side of adjustable motor sheave.

Figure 16.1 - Motor Sheave Adjustment

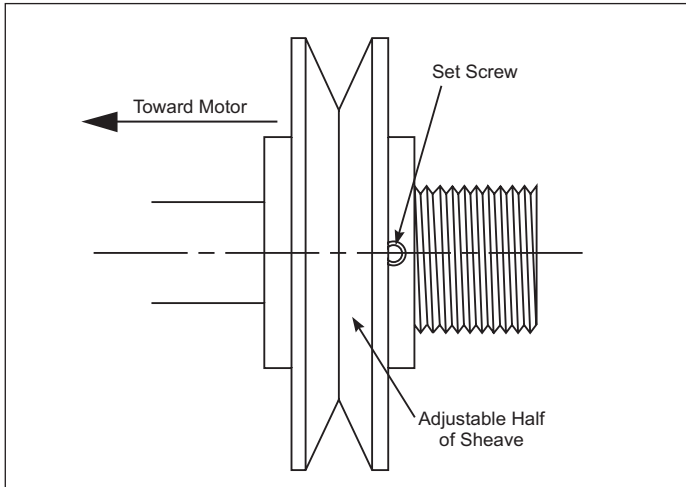

4. Turn outer side of motor sheave clockwise until motor sheave is fully closed.
5. From fully closed position, turn outer side of motor sheave counterclockwise until the proper number of turns open are achieved.
6. Retighten motor sheave set screw, replace belt and retighten motor base. Motor base should be shifted for proper belt tension which is 3/4" deflection with about 5 lbs. of force.

Figure 16.2 - Belt Tension Adjustment

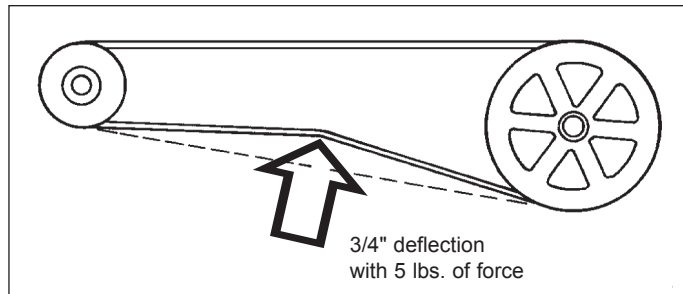

7. Recheck blower rpm after adjustment.
NOTE: Do not fire unit until blower adjustment has been made or unit may cycle on high limit control.
8. Check motor amps. Do not exceed nameplate amps shown on motor nameplate.

Lubrication Recommendations

The blower can be provided with either spider or pillow block bearings. Spider bearings are permanently lubricated and do not require lubrication. Pillow block bearings are shipped greased from the factory but will require lubrication. The bearings should be checked and lubricated before each heating season but a more frequent lubrication schedule may be required based on the environment in which the unit is installed, and the frequency of the equipment operation. Shell Alvania #2 lubricant is recommended.

Damper Linkage Adjustment

If the unit is provided with a return air damper, to prevent shipping damage, the return air damper linkage is disconnected and the damper closed. Before operating the unit, the fresh and return air dampers must be connected. This is accomplished by the following:

1. The damper actuator should be de-energized and the fresh air damper in a fully closed position.
2. Open the return air damper in a fully open position.
3. Slide the connecting rod into the ball joint on the blade arm with the return air damper fully open. See Figure 16.3.
4. Tighten the 5/16" hex head screw on the ball joint.

Figure 16.3 - Damper Linkage Adjustment

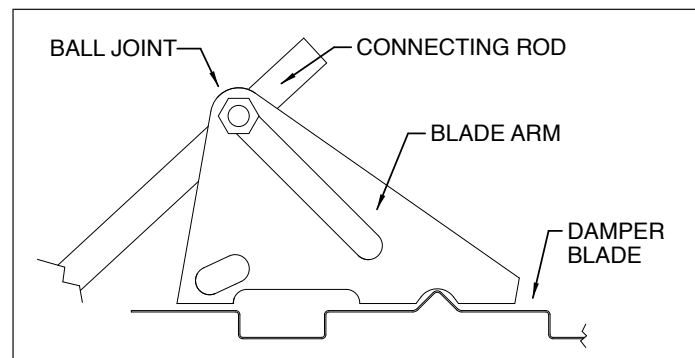

Cooling Coil Operation

1. Proper air distribution is vital to coil performance. Air flow anywhere on the coil face should not vary by more than 20%.
2. Air velocities should be maintained between 200 and 550 feet per minute.
3. For chilled fluid coils, fluid velocities should be maintained within the recommended values of 1 to 8 feet per second (fps) for Water and 1 to 6 fps for Glycol solutions.

START- UP PROCEDURE

Control Operating Sequence

IMPORTANT

To prevent premature heat exchanger failure, with all control systems, a blower starting mechanism must be provided so that the blower is running or energized within 45 seconds of the gas control operation.

Indoor duct furnaces are supplied with intermittent pilot systems with continuous retry, which both the main burner and pilot burner are turned off 100% when the thermostat is satisfied. On a call for heat, the system will attempt to light the pilot for 70 seconds. If the pilot is not sensed for any reason, the ignition control will wait for approximately six minutes with the combination gas control closed and no spark. After six minutes, the cycle will begin again. After three cycles, some ignition controllers lockout for approximately one hour before the cycle begins again. This will continue indefinitely until the pilot flame is sensed or power is interrupted to the system.

Note: Gas Control Options (see page 19) could change the listed sequence of operation based on their function. The descriptions given are for the basic duct furnace.

Single Furnace Controls

Staged Control (Digit 12=1 or 2):

These units utilize a single- or two-stage combination gas valve, an ignition control, and a low voltage thermostat.

Electronic Modulating Control (Digit 12=4, 7, or 8):

These units utilize a single-stage combination gas valve, an electronic modulating gas valve, a modulating amplifier, an ignition control, and one of the following:

- Modulating room thermostat
- Modulating duct thermostat with remote temperature set point adjuster
- Building Management System (BMS) signal by others (an inverted signal where 0 VDC or 4 mA is high fire and 10 VDC or 20 mA is low fire).

The control operating sequence for all units is as follows:

1. The thermostat calls for heat. For BMS controlled units, the BMS closes a heat enable contact at the unit.
2. The power exhaustor relay is energized starting the power exhaustor motor. Once the motor has reached full speed, the differential pressure switch closes. The power exhaustor pre-purge time delay relay then closes after 20 to 40 seconds and energizes the gas control circuit.
3. The pilot valve opens and the spark igniter sparks in an attempt to light the pilot. (If the unit was not provided with a time delay relay, the blower starts).
4. Once the pilot is lit, the flame sensor proves the pilot and stops the spark igniter from sparking.
5. The main gas valve is opened and the main burner is controlled as follows:
 - a. **Single-Stage Units:** The main burner is lit to 100% full fire.
 - b. **Two-Stage Units:** The main burner is lit to 50% fire. If the temperature at the thermostat continues to fall, the thermostat will call for high stage heat and the main burner is lit to 100% full fire.
 - c. **Modulating Thermostat (Room or Duct):** The main gas valve is opened 100% and the burner firing rate is modulated between 40% and 100% full fire. A resistance signal (8000 to 12000 ohms) in the thermostat is converted by the modulating amplifier to an inverted DC voltage

(0VDC for high fire to 12 VDC for low fire). The output voltage is applied to the modulating gas valve to control the gas flow to the main burner. The modulating valve is modulated open or closed based on the voltage from the amplifier (less gas flow required = higher voltage, more gas flow required = lower voltage).

Note: When modulating duct sensing is utilized, a room override thermostat can be added. When the room override calls for heat, the burner modulates to full fire operation until the room override is satisfied. The unit then reverts back to duct sensing control. When equipped with both, either the duct sensor or the room override thermostat can call for heat.

- d. **BMS Signal:** The main gas valve is opened 100% and the burner firing rate is modulated between 40% and 100% full fire. A BMS 0-10VDC or 4-20mA signal (inverted, such that 0 VDC or 4 mA is high fire and 10 VDC or 20 mA is low fire) is converted by the signal conditioner/modulating amplifier into an inverted DC voltage (0VDC for high fire to 12 VDC for low fire). The output voltage is applied to the modulating gas valve to control the gas flow to the main burner. The signal conditioner can accept a 0-10 VDC signal when all the dip switches are in the "OFF" position and 4-20 mA signal when all the dip switches are in the "ON" position. The modulating valve is modulated open or closed based on the voltage from the amplifier (less gas flow required = higher voltage, more gas flow required = lower voltage), which correlates to the control signal from the BMS.

Note: For further information regarding the operation of any of the electronic modulating system options above, consult the literature provided with the unit.

6. If the unit was provided with a time delay relay, the blower starts after 30 to 45 seconds.
7. The unit continues to operate until the thermostat is satisfied, Once satisfied:
 - a. **Single-Stage Units:** Both the main and pilot valves close 100%.
 - b. **Two-Stage Units:** Once the high stage of the thermostat is satisfied, the main valve closes to 50% fire. The unit continues to operate until the low stage thermostat is satisfied, at which time both the main and pilot valves close 100%.
 - c. **Electronic Modulation Units:** The unit continues to operate in this manner until the thermostat is satisfied or the BMS heat enable contact opens. Power is then cut to both the main and pilot valves, closing them 100% and stopping gas flow to the main and pilot burners.
8. If the unit was not provided with a time delay relay, the blower stops immediately. If the unit was provided with a time delay relay, the blower stops after 30 to 45 seconds.

START-UP PROCEDURE

Multiple Furnace Controls

Staged Control (Digit 12=1):

For control of multiple staged units, each furnace would be individually controlled. Refer to the section for Single Furnace Controls, Staged Control (Digit 12=1 or 2).

Electronic Modulating Control (Digit 12=4):

These units are the same as Electronic Modulating Gas Controls – Single Furnace (Digit 12=4) except the Master unit features a modulating amplifier capable of driving multiple modulating gas valves for systems with a Master and up to two Slave units. Slave units do not have a modulating amplifier.

The units would be controlled by one of the following:

- Modulating room thermostat
- Modulating duct thermostat with remote temperature set point adjuster

The sequence of operation for Electronic Modulating Gas Controls - Master/Slave is the same as Electronic Modulating Gas Controls - Single Furnace. The modulating amplifier sends an equal voltage signal to all of the modulating gas valves so that they modulate at the same percentage, between 40% and 100% full fire.

Electronic Modulating Control (Digit 12=7, or 8):

For control of multiple electronic modulation units for BMS control, each furnace would be individually controlled. Refer to the section for Single Furnace Controls, Electronic Modulation Control (Digit 12=7 or 8).

Variable Air Movement Applications

Units may be supplied with variable frequency drives for applications where variable air volume is required. The minimum air flow may be varied between 30 and 100% of the full speed air flow depending on the controls selection of the unit. Due to the extra restrictions of the controller all selections must be performed with the AccuSpec configuration software. Within AccuSpec, three variable frequency drive speed control changeover options are available:

1. Two speed which may be controlled by a manual high/low switch which may be factory mounted on the control panel or shipped loose for field installation or by exhaust fan interlocks.
2. Floating building pressure sensing which utilizes a photohelic pressure controller to adjust the building pressure by varying the amount of makeup air supplied to the the space.
3. Building management control which allows for an external signal of 0-10VDC of 4-20mA to adjust the unit airflow.

The allowable minimum CFM of the system can be 66% of the minimum listed CFM in Table 27.1 if the unit is applied as follows:

1. The unit is provided with 2-stage or electronic modulating gas controls.
2. The unit is provided with a discharge air thermostat.
3. The system does not include a room thermostat.

The discharge air thermostat will prevent the unit from firing above the allowable 100°F rise when the unit is at or above the minimum CFM by monitoring the discharge air and going to low fire. A room thermostat, because it is located remote from the unit, could cause the unit to over-fire.

OPTIONS - FACTORY INSTALLED

Figure 19.1 - Factory Mounted Option Locations

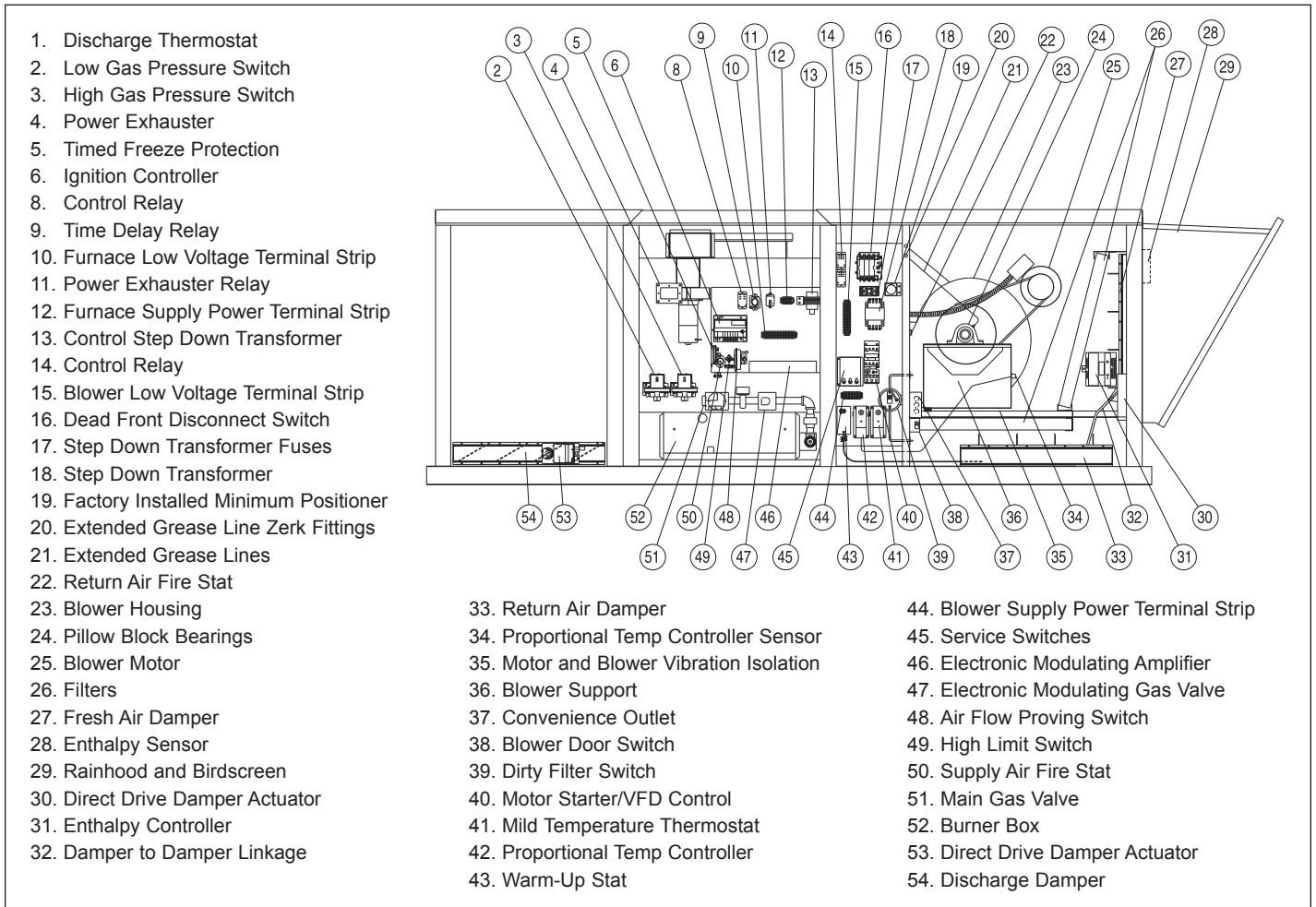

All units include the standard (STD) features. The unit must be reviewed to determine the optional (OPT) features that may have been supplied with the unit.

(1) Discharge Thermostat – (OPT) (Not Shown)

The discharge thermostat is field installed in the discharge air stream of the unit. For additional information, refer to the thermostat vendor literature provided in the literature packet with the unit. Model Sizes 500-960 contain multiple furnaces so multiple thermostats/sensors may be included. The thermostat(s) provided can be one of the following:

- a) Two-stage Capillary Type Thermostat – The thermostat includes a thermostat body and capillary to be field installed in duct work. The thermostat body contains the discharge air set point adjuster that must be field set.

Figure 19.2 - Two-Stage Capillary Type Thermostat

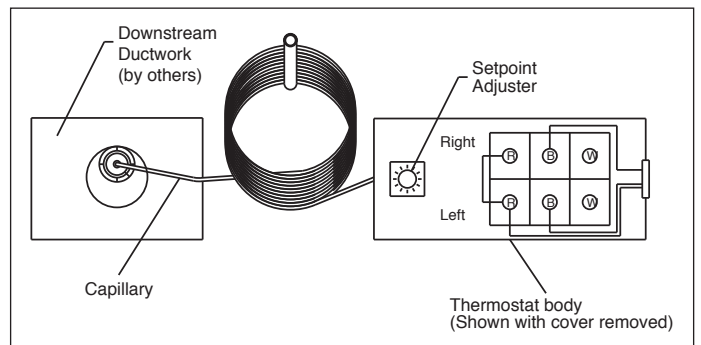

OPTIONS

- b) Two-stage Electronic Type Thermostat - Includes a field installed discharge air sensor. The thermostat body is field installed remotely and includes the discharge air set point adjuster that must be field set. Refer to Literature 5-577 latest revision.

Figure 20.1 - Two-Stage Electronic Type Thermostat Sensor



- c) Electronic Modulating Discharge Air Thermostat – Includes a field installed mixing tube and discharge air sensor field installed in duct work. The set point adjuster is field installed remotely and must be field set. Refer to Literature 5-578 latest revision.

Figure 20.2 - Electronic Modulating Discharge Air Thermostat

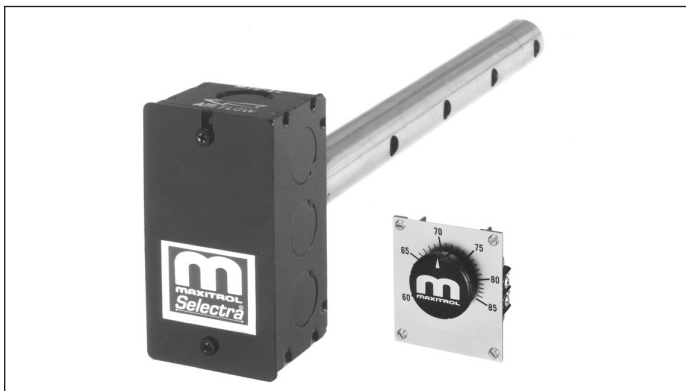

(2) Low Gas Pressure Switch – (OPT)

The low gas pressure switch is factory installed in the duct furnace above the gas train. The switch monitors the gas pressure upstream of all the gas controls and shuts off the electric supply to the ignition controller and combination gas valve if low gas pressure is experienced. This will shut off all gas flow to the burner. The switch has an automatic reset so that if the gas pressure is interrupted and then is returned, the switch will automatically allow the unit to operate when gas conditions are returned to the allowable range of the pressure switch. The pressure switch range is 2" to 14" W.C. and should be set to insure that the minimum inlet gas pressure is available (6" W.C. for natural gas, 11" W.C. for propane gas).

(3) High Gas Pressure Switch – (OPT)

The high gas pressure switch is factory installed in the duct furnace above the gas train. The switch monitors the gas pressure downstream of all the gas controls and shuts off the electric supply to the ignition controller and combination gas valve if high gas pressure is experienced right before the manifold. This will shut off all gas flow to the burner. The switch has a manual reset so that if the gas pressure is too high, a service person must check the unit to make sure that none of the gas controls have been damaged by the high gas pressure and then reset the switch to allow the unit to operate when gas

Figure 20.3 - Low or High Gas Pressure Switch



conditions are returned to the allowable range of the pressure switch. The pressure switch range is 2" to 16" W.C. and should be set to insure that the maximum manifold gas pressure is not exceeded (3.5" W.C. for natural gas, 10" W.C. for propane gas).

(4) Power Exhauster – (STD)

The power exhauster is factory installed in the duct furnace section. On a call for heat, the power exhauster creates a combustion draft through the duct furnace prior to the pilot being energized. The draft is proven through the power exhauster motor centrifugal switch that closes when the motor reaches full speed. The unit door includes a factory installed power exhauster discharge cover and inlet combustion louvers. For information about venting, refer to the Installation – Venting section.

(5) Timed Freeze Protection – (OPT)

The timed freeze protection system is factory installed in the duct furnace electrical junction box with the sensor (30°-75°F adjustable) factory installed in the discharge air stream. On initial start-up, the timed delay in the system allows the unit to go through the normal ignition sequence. The timed delay is a manual reset switch and adjustable for 1-10 minutes. In the event that the unit fails to fire after this period, the discharge air sensor will sense the cold air and will shut down the entire unit.

Figure 20.4 - Timed Freeze Protection Module

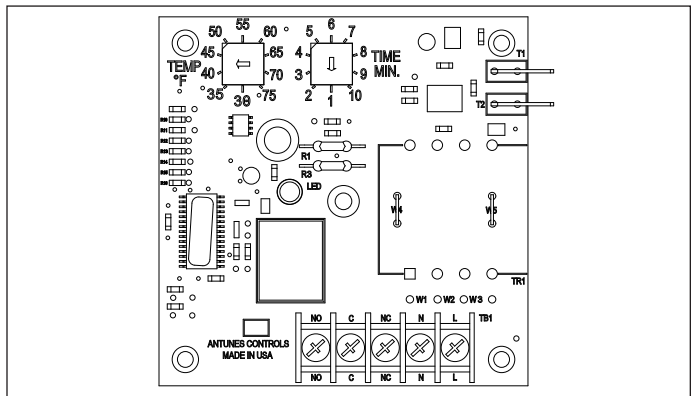

(6) Ignition Controller – (STD)

The ignition controller is factory installed in the duct furnace electrical junction box with the spark ignitor and sensor located on the burner.

For both natural and propane gas units, the ignition controller is 100% shut-off with continuous retry. On a call for heat, the system will attempt to light the pilot for 70 seconds. If the pilot is not sensed for any reason, the ignition control will wait for approximately six minutes with the combination gas control closed and no spark. After six minutes, the cycle will begin again. After three cycles, some ignition controllers lockout for approximately one hour before the cycle begins again. This will continue indefinitely until the pilot flame is sensed or power is interrupted to the system.

OPTIONS

(8) Control Relay – (OPT)

The control relay is factory installed in the duct furnace electrical junction box. The relay has a 24V coil with double-pole, double throw (DPDT) contacts. Refer to the unit wiring diagram for the function of the switching operation of the relay. The two normally open and two normally closed contacts are rated for a maximum of 30 amps @ 115V/1Ph.

(9) Time Delay Relay – (STD)

The time delay relay is factory installed in the duct furnace electrical junction box. The time delay relay allows the gas controls to operate for approximately 30 seconds before the blower starts. This allows the heat exchanger a warm up period so that the initial delivered air coming out of the ductwork is not cool. The time delay relay also keeps the motor running for approximately 30 seconds after the call for heat has been satisfied to remove the residual heat from the heat exchanger. For single phase units below 1-1/2 Hp, the time delay relay controls the motor directly. For single phase units 1-1/2 Hp and greater and all three phase units, the time delay relay controls the motor starter.

(10) Furnace Low Voltage Terminal Strip – (STD)

The furnace low voltage terminal strip is located in the duct furnace electrical junction box. The terminal strip is labeled to match the electrical wiring diagram provided with the unit. Low voltage labeling ranges from terminal numbers 1 to 79. All field wiring connections should be made to the top side of the terminals to prevent miswiring by modifying the factory wiring which is made to the bottom of the terminal strip.

(11) Power Exhaust Relay – (STD)

The control relay is factory installed in the duct furnace electrical junction box. The relay has a 24v coil with single-pole single throw (SPST) contacts. On a call for heat, the relay coil is energized resulting in the contacts energizing the power exhauster motor.

(12) Furnace Supply Power Terminal Strip – (STD)

The furnace supply power terminal strip is located in the duct furnace electrical junction box. The terminal strip is labeled to match the electrical wiring diagram provided with the unit. Supply power labeling ranges from terminal numbers 80 to 99. All field wiring connections should be made to the bottom side of the terminals to prevent miswiring by modifying the factory wiring which is made to the top of the terminal strip.

(13) Control Step Down Transformer – (STD)

The control step down transformer is located in the duct furnace electrical junction box. The transformer is used to step down the supply power (115V, 208V, 230V, 460V, 575V) to 24V. This transformer is used to control the gas controls, damper actuator, motor starter, etc. Refer to the unit model number to determine the volt- amp (VA) capacity of the duct furnace. The 15th digit indicates the VA (See Model Nomenclature).

(14) Control Relay – (OPT)

The control relay is factory installed in the electrical section. See description of Option 8 for additional details.

(15) Blower Low Voltage Terminal Strip – (STD)

The blower low voltage terminal strip is located in the electrical section. The terminal strip is labeled to match the electrical wiring diagram provided with the unit. Low voltage labeling ranges from terminal numbers 1 to 79. All field wiring connections should be made to the right side of the terminals to prevent miswiring by modifying the factory wiring which is made to the left side of the terminal strip.

(16) Dead Front Disconnect Switch – (OPT)

⚠ WARNING

When the dead front disconnect switch is in the “OFF” position, supply power remains energized at the blower supply power terminal strip and the top of the dead front disconnect switch. When providing service on or near these terminals, building supply power to the unit should be de-energized.

The dead front disconnect switch is factory installed in the electrical section. The disconnect switch is designed so that it must be turned “OFF” before entry to the electrical control cabinet can be obtained (See Figure 21.1). When in the “OFF” position, power is disconnected to all unit wiring electrically following the switch (See Warning). For servicing the unit, the disconnect switch can be manually overridden by using a wrench and turning the disconnect switch shaft 90° clockwise (See Figure 21.1). Fusible and circuit breaker switches available. For fusible switches, Class “J” time delay fuses must be field provided matching the fuse size listed on the Model Identification plate.

Figure 21.1 - Dead Front Disconnect Switch Assembly

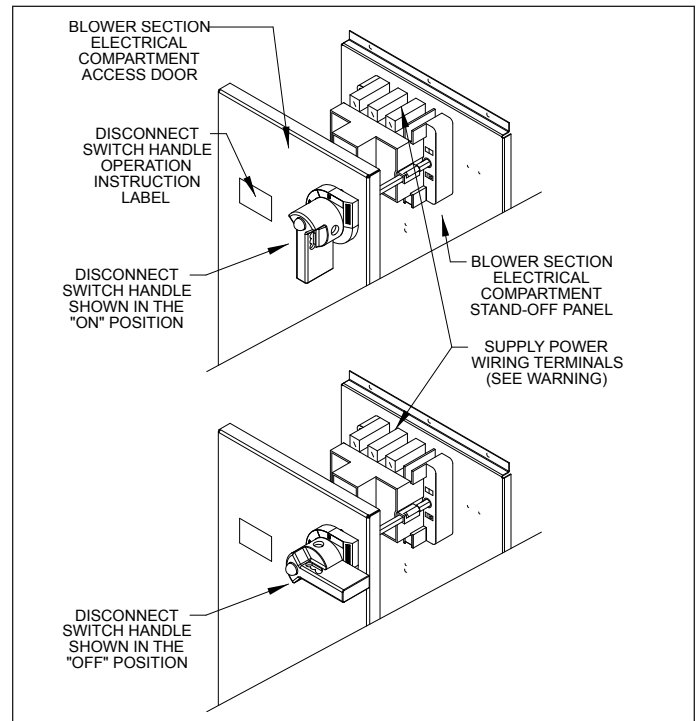

(17) Step Down Transformer Fuses – (OPT)

The transformer fuses are factory installed in the electrical section. The fuses are included to protect the transformer. Fuses included.

(18) Step Down Transformer – (OPT)

The step down transformer is factory installed in the electrical section. The transformer is required for power exhausted units (Digit 2 = P) with a supply voltage of 460V/3Ph and 575V/3Ph and all units that have an evaporative cooler (Digit 22 = 3,4,5, or 6).

For all units with an evaporative cooler, when the supply power voltage is 208V/1Ph or 208V/3Ph, the transformer is provided to step down the voltage from 208V to 115V. In this case, the evaporative cooler pump motor operates at 115V.

For power exhausted units and all units with an evaporative cooler, when the supply power voltage is 460V/3Ph or 575V/3Ph, the transformer is provided to step down from supply power voltage to 115V. In this case, the evaporative cooler pump motor operates at 115V.

OPTIONS

(19) Factory Installed Minimum Positioner – (OPT)

The factory installed minimum positioner is installed in the electrical section and is used with a modulating damper actuator to set the minimum percentage of outside air. The minimum positioner dial is manually set between 0 to 100% resulting in a 2 to 10 VDC signal being sent to the damper actuator. When used in conjunction with the Proportional Temp Controller, the positioner sets the minimum outside air percentage and the Proportional Temp Controller then modulates between the minimum position and 100% outside air.

Figure 22.2 - Minimum Positioner

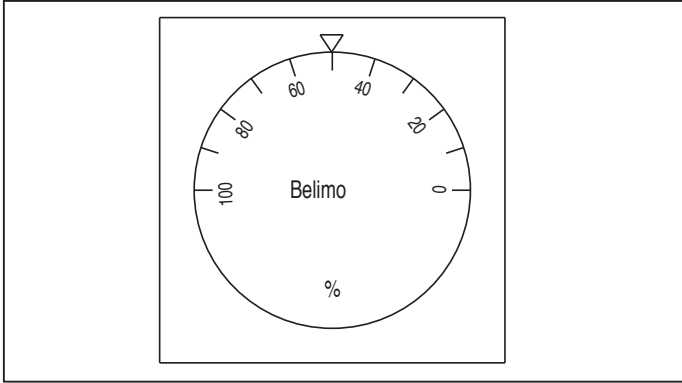

(20, 21) Extended Grease Lines – (OPT)

The extended grease lines (21) are factory installed in the blower section and include Zerk® grease fittings (20) factory installed on the exterior corner post between the electrical and blower sections. This option allows the pillow block bearings to be lubricated with a grease gun without requiring the service personnel to remove both blower doors to access the bearings. Refer to Lubrication Recommendations for lubricant recommendations.

(22) Return Air Fire Stat – (OPT)

The return air fire stat is factory installed in the electrical section with the sensor in the return air stream. In case of elevated temperatures in the return air stream, the manual reset switch shuts down the entire unit. If the limit temperature is exceeded, a service person must inspect the unit for the cause of the high discharge temperature, take corrective action, and then reset the switch.

(23) Blower Housing – (STD)

The blower housing is factory installed in the blower section. The blower housing contains a double width, double inlet (DWDI) blower wheel so both sides of the blower must be free from obstructions for proper operation. For Right Hand units (Digit 9 = R), during operation the blower wheel should rotate in the clockwise direction when viewed from the service side of the unit. For Left Hand units (Digit 9 = L), during operation the blower wheel should rotate in the counterclockwise direction when viewed from the service side of the unit. If necessary, interchange supply power wiring to reverse blower rotation.

(24) Pillow Block Bearings – (OPT)

The pillow bearings are factory installed in the blower section. The blower can be provided with either spider or pillow block bearings. Spider bearings are permanently lubricated and do not require lubrication. Pillow block bearings are shipped non-greased from the factory and require lubrication before start-up. For lubrication recommendations, see Lubrication Recommendations.

(25) Blower Motor – (STD)

The blower motor is factory installed in the blower section. The blower motor can be provided in a variety of supply voltages, frame types, and motor horsepower. Refer to the model nomenclature to determine the type of motor provided. The

blower motor is supplied with an adjustable sheave that can be used to increase/decrease the blower RPM. For instructions on changing the blower RPM, refer to Blower Adjustments.

(26) Filters – (OPT)

When filters are supplied with the unit, a rack and the filters are factory installed in the blower section. The unit can be supplied with 1" or 2" permanent filters, 2" FARR® Aeropleat MERV 7 or 2" FARR® 30/30 MERV 8 filters. For filter replacement, refer to Maintenance.

(27) Fresh Air Damper – (OPT)

When a fresh air damper is supplied with the unit, the damper is factory installed in the blower section. The fresh air damper is used as an outside air shut-off damper, so ultra low leak, Class II leakage resistance (less than 10 CFM/ft² at 1" W.C.) dampers with self-compensating stainless steel side seals and santoprene and galvanized steel blade seals are used.

(29) Rainhood and Birdscreen – (OPT)

The rainhood and birdscreen is shipped loose for field installation at the back of the blower section. For installation instructions, refer to Literature 5-589 supplied with the rainhood and birdscreen.

(30) Direct Drive Damper Actuator – (OPT)

The direct drive damper actuator is factory installed in the blower section on the side of the fresh air damper. The actuator controls the position of the fresh air damper. The return air damper, if provided, is controlled by the damper linkage between the two dampers. All damper actuators are low voltage (24V). For Right Hand units (Digit 9 = R), during operation the actuator should rotate in the counterclockwise direction when viewed from the service side of the unit. For Left Hand units (Digit 9 = L), during operation the actuator should rotate in the clockwise direction when viewed from the service side of the unit. Three different types of dampers actuators can be provided: Two-position, Modulating, and Floating.

Two-position Damper Actuator: A two-position damper actuator is provided with Air Control options DA, EA and EQ (Digits 20 & 21). The two-position damper actuator provides open/closed operation of the fresh air damper. When the damper is energized, the fresh air damper is opened to 100% outside air in 75 seconds (for outside air percentages lower than 100%, refer to the following section, "Setting the Damper Limiter"). All two-position damper actuators are spring return, so when the damper is de-energized, the fresh air damper will spring closed. All two-position dampers include auxiliary switches (one normally open and one normally closed) that reverse when the damper actuator is at 85° rotation (adjustable).

Setting the Damper Limiter: The two-position damper limiter is factory set to prevent the outside air damper from opening 100%. Field adjustment of the two-position damper limiter is accomplished by the following:

1. Determine the amount of damper rotation required (Percentage of outside air).
2. Locate the angle of rotation limiter on the actuator so that its edge lines up with the degree graduation on the actuator face which corresponds with the required rotation. (See Figure 23.1 which is shown at 50% rotation limit.)
3. Position the limiter back to the desired position, making sure the locating "teeth" on the limiter are engaged into the locating holes on the actuator.
4. Fasten the limiter to the actuator using the screw provided.
5. Test the damper rotation either manually with the manual crank or apply power. Re-adjust if necessary.
6. If the damper end switch is being used in the control circuit and needs to be adjusted for the new minimum position, refer to the next section, "Adjusting the Damper End Switch".

OPTIONS

Figure 23.1 - Two-position Damper Actuator and Limiter

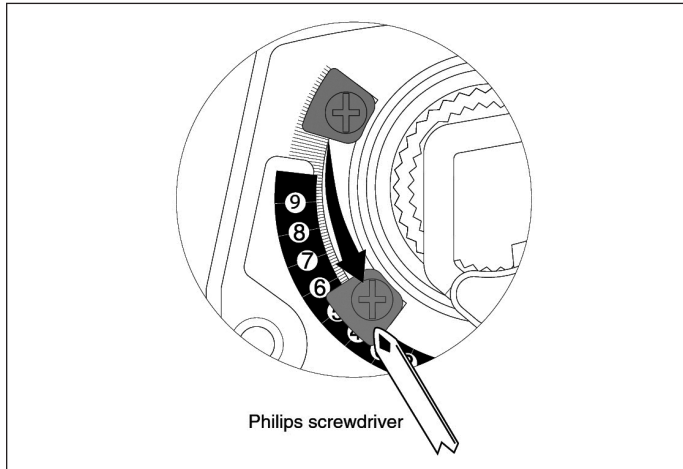

Adjusting the Damper End Switch

If the damper limiter was adjusted in the previous section, it may be required to adjust the Damper End Switch as follows:

- 1 The actuator must be in its fail-safe position.
2. Insert the crank handle into the torx shaped hole located in the center of the adjustable switch pointer as shown in Figure 23.2.
3. Gently rotate the crank until the switch pointer is at the desired switch point in degrees as shown.

Figure 23.2 - Adjusting the Damper End Switch

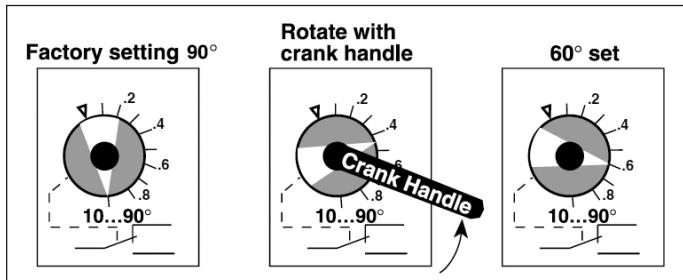

Modulating Damper Actuator: A modulating damper actuator is provided with Air Control options GA, GB, GC, GD, GE, GG, GH, GJ, GK and GM (Digits 20 & 21). The modulating damper actuator provides incremental operation of the fresh air damper (The return air damper is controlled by the fresh air damper position). Full 90° rotation of the modulating actuator requires 150 seconds. All modulating damper actuators operate using a 0-10 Vdc input signal (Air Control GB utilizes a resistor to convert from a 4-20 mA to 0-10 Vdc) from a damper controller.

All modulating damper actuators are spring return, so when the damper is de-energized, the fresh air damper will spring closed.

Floating Damper Actuator: A floating damper actuator is provided with Air Control option HP (Digits 20 & 21). The floating damper actuator provides forward and reversing damper operation in response to contact closures from the space pressure controller. When the space pressure is above the desired set point, a high pressure contact on the space pressure controller energizes the damper to drive the fresh air damper closed. When the space pressure is below the desired set point, a low pressure contact on the space pressure controller energizes the damper to drive the fresh air damper open. When the space pressure is between the high and low set points, the damper “floats” at the fresh air percentage that satisfied the space pressure controller. Full 90° rotation of the floating actuator requires 150 seconds. For additional information on the space pressure controller, refer to Literature 5-585.

The damper actuator is designed to “float” and therefore it is not spring return. When the unit is de-energized under normal operation, the fresh air damper is closed by a relay contact

closure which electrically drives the damper closed. If the supply power to the unit is interrupted before the damper actuator can drive closed, the fresh air damper will remain open. The damper can be manually closed through the use of the manual override switch on the floating damper actuator.

(31) Enthalpy Controller – (OPT)

An enthalpy controller is provided with Air Control option GJ (Digits 20 & 21) and factory installed in the blower section. The purpose of the enthalpy controller is to use outside air for cooling, whenever possible, to reduce compressor operation of the mechanical cooling system. The economizer functions as a true first stage of cooling and provides maximum fuel economy during the cooling cycle.

The components used for the Enthalpy Economizer are:

- **Enthalpy Economizer Controller.** The Enthalpy Controller is used in conjunction with the Enthalpy Sensor and a Mixed Air Temperature sensor. The controller is factory mounted in the blower control cabinet.
- **Outside Air Enthalpy Sensor.** The sensor provides a signal in relation to enthalpy (temperature and humidity) of the outside air. The sensor is installed in the outside air stream.
- **Mixed Air Temperature Sensor.** The sensor is factory installed in the blower section to sense the mixed air temperature of the fresh and return air streams.

Typical Sequence of Operation

Heating or Ventilation Mode

When the space thermostat calls for heat or the fan is on without a call for cooling (ventilation mode), the economizer is automatically locked out and holds the outdoor air damper at the minimum position setting. The minimum position adjustment keeps the outdoor air damper from closing completely during system operation to provide ventilation in both the heating and cooling modes.

Cooling Mode

When the space thermostat calls for cooling, the system operates as follows:

Outdoor Air Enthalpy is Below Changeover Set Point

1. The outdoor air damper is proportioned open (and the return air damper is proportioned closed) to maintain a temperature of 53°F (default, adjustable) at the mixed temperature air sensor.
2. During economizer operation, mechanical cooling is operated by the second stage of the cooling on the space thermostat.

Outdoor Air Enthalpy is Above Changeover Set Point

1. The outdoor air damper is closed to its minimum position.
2. A call for cooling from the space thermostat brings on mechanical cooling.

For complete details on the Enthalpy Economizer controller setup and operation, please refer to the latest revision of Modine publication 5-598, "Setup Instructions, Enthalpy Economizer Controller".

Figure 23.3 - Enthalpy Controller



OPTIONS

(32) Damper to Damper Linkage – (OPT)

Units with fresh and return air dampers include a damper actuator that controls the fresh air damper. The return air damper position is controlled by the fresh air damper through the connecting rod. For adjustment, refer to Damper Linkage Adjustment.

(33) Return Air Damper – (OPT)

When a return air damper is supplied with the unit, the damper is factory installed in the blower section. The return air damper is used as an air balancing damper so low leak, Class III leakage resistance (less than 40 CFM/ft² at 1" W.C.) dampers with self-compensating stainless steel side seals and santoprene blade seals are used.

(34) Proportional Temperature Controller Sensor – (OPT)

A proportional temperature controller sensor is provided with Air Control options GG, GH, GK or GM (Digits 20 & 21) and factory installed in the blower section. The sensor provides the mixed air temperature signal to the A350P Proportional Temperature Controller which is mounted in the electrical section.

(35) Motor and Blower Vibration Isolation – (STD)

The motor vibration isolation is factory installed in the blower section below the blower support bracket. The four (4) 13/32"-neoprene vibration mount grommet provides isolation of the blower housing and motor from the blower support channels. The blower vibration isolation is factory installed in the blower section between blower discharge and the blower duct connection. The blower duct connection is not rigidly mechanically fastened and the 1/4" thick gasketing around the duct transition provides vibration isolation.

Figure 24.1 - Blower/Motor Vibration Isolation

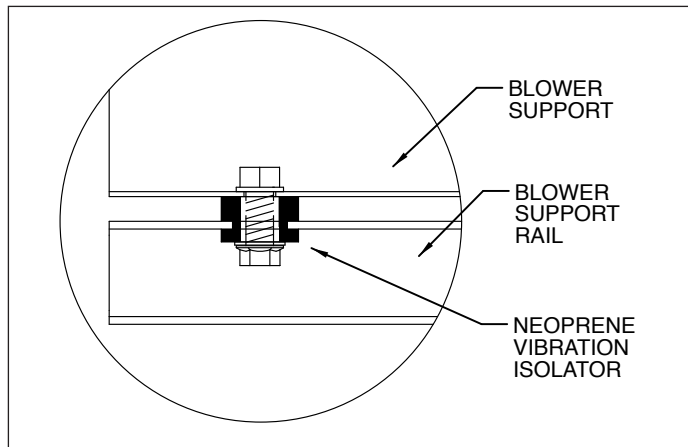

(36) Blower Support – (STD)

The blower supports are factory installed in the blower section. The blower supports are used to rigidly support the weight of the blower and motor during operation and shipping.

(37) Convenience Outlet – (OPT)

⚠ WARNING

Do not perform service on the convenience outlet without disconnecting its power supply. The convenience outlet power supply is separate from main power supply to the unit. When the main disconnect switch is de-energized, the convenience outlet power supply remains energized.

The convenience outlet is factory installed in the blower section for providing power for 115V service equipment (trouble light, power tools, etc.). The 115V ground fault circuit interrupter (GFCI) is rated for 15 amps and includes test and reset switches. A separate field supplied 115V/1Ph power supply must be routed through the electrical section wall into the back of the convenience outlet junction box.

(38) Blower Door Switch – (OPT)

The blower door switch is factory installed inside the blower section door on the access side of the unit. When the blower section door is removed, the momentary switch is released and interrupts power to the low voltage circuit. For single phase units 1-1/2 Hp and less, the door switch de-energizes a relay that controls blower motor operation. For three phase units and single phase units 1-1/2 Hp and greater, the door switch de-energizes the motor starter that controls blower motor operation. For servicing, the switch is equipped with an override position that can be manually pulled out to override the switch. (See Figure 24.2).

Figure 24.2 - Blower Door Switch with Manual Override

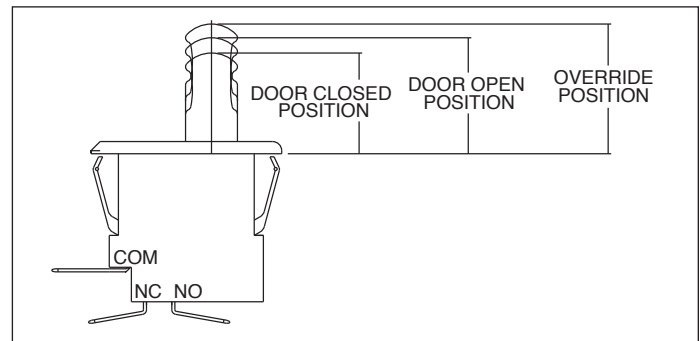

(39) Dirty Filter Switch – (OPT)

The dirty filter pressure switch is factory installed in the electrical section. The dirty filter pressure switch monitors the pressure differential between the two sides of the filters. When the filters become dirty, the differential pressure increases and trips the pressure switch which energizes a light on the remote monitoring panel. The pressure differential switch must be field set because setting the switch requires the blower to be in operation and the ductwork to be installed.

Setting the Dirty Filter Switch

The range of the dirty filter pressure switch is adjustable between 0.17" to 5.0" W.C.

1. Ensure that the unit filters are clean. Clean or replace if necessary.
2. Connect the leads of a continuity tester to the NO and C terminals of the dirty filter pressure switch. See Figure 25.1
3. Set the thermostat so that there is a call for heat. This should fire the burner and the blower should start.
4. Turn the set screw of the pressure switch clockwise until it stops. This will set the pressure at 5.0" W.C. and the continuity tester should be sensing an open circuit.
5. Begin turning the screw counterclockwise until the continuity tester senses a closed circuit. This determines the base pressure of the system.
6. Turn the screw clockwise until the continuity tester senses an open circuit and then one additional full turn (This is approximately 0.25" W.C.) This will allow for the increase in static pressure due to dirty filters.

OPTIONS

Figure 25.1 - Dirty Filter Pressure Switch and Air Flow Proving Switch

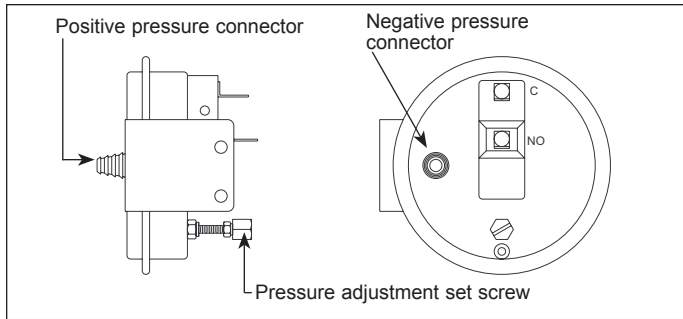

(40) Motor Starter – (OPT)

The motor starter is factory installed in the electrical section. A motor starter is required for all three phase motors and single phase motors 1-1/2 Hp and greater. The motor starter current set point dial is factory set to the motor full load amp draw listed on the motor nameplate.

(40) Variable Frequency Drive – (OPT)

The VFD controller adjusts the motor rpm to vary the unit air flow. The minimum air flow may be varied between 30 and 100% of the full speed air flow depending on the controls selection of the unit. The control changeover options are two speed, floating building pressure sensing, and building management control.

The overload module of the motor starter is designed to trip to protect the motor from exceeding the nameplate amps. If the motor exceeds the amp draw on the current set point dial, the trip condition is indicated by a red color in the trip indicator window. The motor starter can be placed in the automatic or manual reset positions. Automatic reset is accomplished by depressing the “RESET” button and turning the button 1/4 turn. When in the automatic reset position, if the overload module trips, the module will reset itself once the overload relay has cooled. In the manual reset position, if the overload module trips, the “RESET” button must be depressed before the blower can operate.

The contractor module includes one (1) normally open auxiliary contact. The contact rating is 10 amps.

If the factory installed motor starter option was not ordered with a unit that has a three phase motor or single phase motor 1-1/2 Hp or greater, a motor starter must be field supplied and installed.

Figure 25.2 - Motor Starter

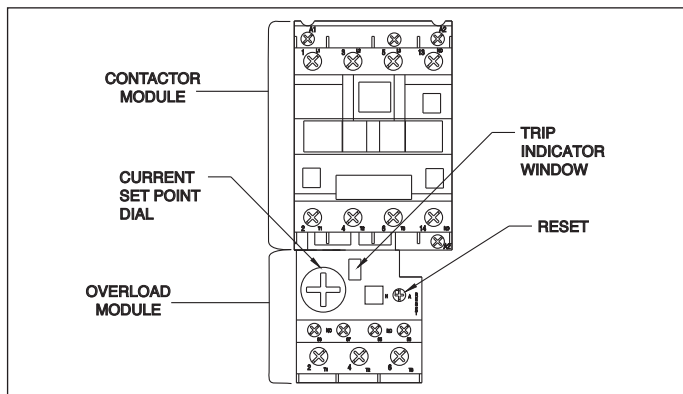

(41) Mild Temperature Thermostat – (OPT)

The mild temperature thermostat is factory installed in the electrical section. The mild temperature thermostat is designed to lockout the burner during mild weather conditions which prevents the burner from cycling. The thermostat must be field set to the desired mild temperature condition (refer to the latest revision of Modine Literature 75-540).

(42) Proportional Temperature Controller – (OPT)

A proportional temperature controller is provided with Air Control options GG, GH, GK or GM (Digits 20 & 21) and factory installed in the electrical section. The controller compares the mixed air temperature set point and the mixed air temperature from the Proportional Temperature Controller Sensor. The controller sends a 2-10 Vdc signal to the modulating damper actuator in order to maintain the set point. The controller includes a set point dial that must be field set to the desired mixed air temperature (typically 55°F).

Figure 25.3 - Proportional Temperature Controller



(43) Warm-Up Stat – (OPT)

A warm-up stat is provided with Air Control options GK or GM (Digits 20 & 21) and factory installed in the electrical section with the sensor in the return air stream. The warm-up thermostat monitors the return air temperature to the unit and prevents the fresh air dampers from opening until the temperature of the return air has reached the desired set point (typically 65°F or 5°F below the room temperature).

(44) Blower Supply Power Terminal Strip – (STD)

The blower supply power terminal strip is located in the electrical section. The terminal strip is labeled to match the electrical wiring diagram provided with the unit. Supply power labeling ranges from terminal numbers 80 to 99. All field wiring connections should be made to the bottom side of the terminals to prevent miswiring by modifying the factory wiring which is made to the top of the terminal strip.

(45) Service Switches – (OPT)

The service switches are factory installed in the electrical section. The service switches allow for service personnel to independently test operation of the damper, blower, and furnace without using jumper wires. The switches override the remote monitoring panel and/or thermostats to energize each component directly. All switches need to be reset to the “OFF” position after testing otherwise the components will remain energized.

Figure 25.4 - Service Switches

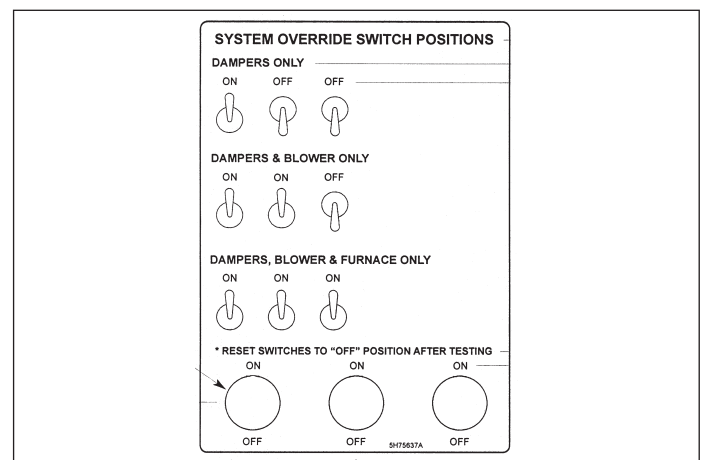

OPTIONS

(46) Electronic Modulation Amplifier – (OPT)

An electronic modulation amplifier is provided factory installed in the duct furnace electrical junction box when the unit is equipped with Electronic Modulating Gas Controls (Digit 12 = 4). The amplifier processes the thermostat temperature and set point signals to modulate the firing rate between 40% to 100% full fire. For additional information, refer to Control Operating Sequence.

(47) Electronic Modulating Gas Valve – (OPT)

An electronic modulating gas valve is provided factory installed in the duct furnace gas train when the unit is equipped with Electronic Modulating Gas Controls (Digit 12 = 4, 7, or 8). The gas valve modulates the firing rate between 40% to 100% full fire based on the input signal from the Electronic Modulation Amplifier or Signal Conditioner. For additional information, refer to Control Operating Sequence.

(48) Air Flow Proving Switch – (OPT)

The air flow proving switch is factory installed in the duct furnace electrical junction box. The air flow proving switch monitors the pressure differential between the duct furnace and the atmosphere. The purpose of the air flow proving switch is to cut power to the gas controls if a positive pressure is not measured by the switch. This could be caused by a lack of air movement through the heat exchanger.

NOTE: The air flow proving switch will prevent any heat exchanger warm-up because the gas controls can not be energized until air flow is proven.

Setting the Air Flow Proving Switch

The range of the air flow proving switch is adjustable between 0.17" to 5.0" W.C.

1. Set the thermostat so that there is a call for heat. This should start the blower and then the burner ignition sequence.
2. Turn the set screw of the pressure switch clockwise until it stops. This will set the pressure at 5.0" W.C.
3. Turn the screw counter-clockwise until the gas controls light and then one additional full turn (This is approximately 0.25" W.C.). This will allow for dirty filters or any other slight static pressure increases in the system.

(49) High Limit Switch

Automatic – (STD)

The automatic reset high limit switch is factory installed in the duct furnace electrical junction box. If the limit temperature is exceeded, the gas controls are de-energized until the switch is cooled.

Manual – (OPT)

The manual reset high limit switch is factory installed in place of the standard automatic reset high limit switch located in the duct furnace electrical junction box. In case of a failure of the blower motor, blockage of the inlet air, etc., the manual reset switch prevents the unit from cycling on the high limit. If the limit temperature is exceeded, a service person must inspect the unit for the cause of the high discharge temperature, take corrective action, and then reset the switch.

(50) Supply Air Fire Stat – (OPT)

The supply air fire stat is factory installed in the duct furnace electrical junction box with the sensor in the discharge air stream. In case of elevated temperatures in the supply air stream, the manual reset switch shuts down the entire unit. If the limit temperature is exceeded, a service person must inspect the unit for the cause of the high discharge temperature, take corrective action, and then reset the switch.

(51) Main Gas Valve – (STD)

The main gas valve is factory installed in the duct furnace gas train. The main gas valve provides the pilot, regulator, main gas, and manual shutoff functions. For additional information, see the supplier literature included with the unit.

(52) Burner Box – (STD)

The burner box is located in the duct furnace section and contains the burner and pilot assembly. The burner box includes an access panel for removal of the burner for inspection and servicing.

(54) Discharge Damper – (OPT)

When a discharge air damper is supplied with the unit, the damper is factory installed in the downturn plenum section. The discharge air damper is used an outside air shut-off damper so ultra low leak, Class II leakage resistance (less than 10 CFM/ft² at 1" W.C.) dampers with self-compensating stainless steel side seals and santoprene and galvanized steel blade seals are used.

(55) Differential Pressure Switch

A differential pressure switch is supplied on all power vented duct furnaces and is designed to prevent operation of the main burner in the event there is improper venting through the vent system. This may occur due to a restricted vent, inadequate vent draw, uninsulated vent pipe in cold ambient or long vent runs, excessive vent diameter, restrictive vent terminal, negative pressure within space, etc. See Troubleshooting section for more information.

(Not Shown) Circuit Analyzer – (OPT)

The circuit analyzer is factory installed on the door of the electrical section. The circuit analyzer is used to quickly assist service personnel in troubleshooting by monitoring the unit firing sequence and vital operating steps. Lights will come on as a point of electrical operation is passed and proven. If any light is not lit, that is the point where failure occurred.

Figure 26.1 - Circuit Analyzer

Circuit analyzer tagging will vary based on the unit ordered. Circuit analyzer shown is for reference only.



GENERAL PERFORMANCE DATA

Table 27.1
General Performance Data - Models With Blower

Model Size (Digits 4-6)	Btu/Hr Input ①	Btu/Hr Out- put ①	Blower Style/Size		Minimum CFM ②	Maximum CFM	Temperature Rise (°F)	
			(Digit 16)	Size			Maximum	Minimum
75	75,000	60,750	A or B	9-7	562	1800	100	31
			C or D	9-9	750	2813	75	20
100	100,000	81,000	C or D	9-9	750	3000	100	25
			E or F	12-12	1500	3750	50	20
125	125,000	101,250	C or D	9-9	937	3000	100	31
			E or F	12-12	1500	4688	63	20
150	150,000	121,500	C or D	9-9	1125	3000	100	38
			E or F	12-12	1250	5550	90	20
175	175,000	141,750	C or D	9-9	1312	3000	100	44
			E or F	12-12	1312	5550	100	24
200	200,000	162,000	C or D	9-9	1500	3000	100	50
			E or F	12-12	1750	5000	86	30
			G or H	15-15	1750	6500	86	23
225	225,000	182,250	C or D	9-9	1687	3000	100	56
			E or F	12-12	1750	5000	96	34
			G or H	15-15	1750	6500	96	26
250	250,000	202,500	E or F	12-12	1875	5500	100	34
			G or H	15-15	1875	6500	100	29
			I, J, or K	18-18	3000	9375	63	20
300	300,000	243,000	E or F	12-12	2250	5500	100	41
			G or H	15-15	2250	6500	100	35
			I, J, or K	18-18	3000	11250	75	20
350	350,000	283,500	E or F	12-12	2625	5500	100	48
			G or H	15-15	2625	6500	100	40
			I, J, or K	18-18	4000	12000	66	22
400	400,000	324,000	E or F	12-12	3000	5500	100	55
			G or H	15-15	3000	6500	100	46
			I, J, or K	18-18	4000	12000	75	25
500	500,000	405,000	G or H	15-15	3125	6500	120	58
			I, J, or K	18-18	4000	9375	94	40
			L	20-18	4000	9375	94	40
600	600,000	486,000	G or H	15-15	3750	6500	120	69
			I, J, or K	18-18	4000	11250	113	40
			L	20-18	5000	11250	90	40
700	700,000	567,000	G or H	15-15	4375	6500	120	81
			I, J, or K	18-18	4375	13000	120	40
			L	20-18	4375	13000	120	40
800	800,000	648,000	G or H	15-15	5000	6500	120	92
			I, J, or K	18-18	5000	13000	120	46
			L	20-18	5000	14500	120	41
840	1,050,000	850,500	I, J, or K	18-18	6562	13000	120	61
			L	20-18	6562	13000	120	61
960	1,200,000	972,000	I, J, or K	18-18	7500	13000	120	69
			L	20-18	7500	14500	120	62

① Ratings are shown for elevations up to 2,000 feet. For higher elevations, refer to section "Considerations for Elevation" on page 10.

② For Variable Air Movement Applications, see page 18.

GENERAL PERFORMANCE DATA

Table 28.1 - Air Temperature Rise ①②③

Model Size	Btu/Hr Input ①	Btu/Hr Output ①	Air Temperature Rise Through Unit (°F)									
			20	40	50	60	70	80	90	100	110	120
75	75,000	60,750	2,813	1,406	1,125	938	804	703	625	562	-	-
100	100,000	81,000	3,750	1,875	1,500	1,250	1,071	938	833	750	-	-
125	125,000	101,250	4,688	2,344	1,875	1,563	1,339	1,172	1,042	937	-	-
150	150,000	121,500	5,500	2,813	2,250	1,875	1,607	1,406	1,250	1,125	-	-
175	175,000	141,750	5,500	3,281	2,625	2,188	1,875	1,641	1,458	1,312	-	-
200	200,000	162,000	6,500	3,750	3,000	2,500	2,143	1,875	1,667	1,500	-	-
225	225,000	182,250	6,500	4,219	3,375	2,813	2,411	2,109	1,875	1,687	-	-
250	250,000	202,500	9,375	4,688	3,750	3,125	2,679	2,344	2,083	1,875	-	-
300	300,000	243,000	11,250	5,625	4,500	3,750	3,214	2,813	2,500	2,250	-	-
350	350,000	283,500	12,000	6,563	5,250	4,375	3,750	3,281	2,917	2,625	-	-
400	400,000	324,000	12,000	7,500	6,000	5,000	4,286	3,750	3,333	3,000	-	-
500	500,000	405,000	-	9,375	7,500	6,250	5,357	4,688	4,167	3,750	3,409	3,125
600	600,000	486,000	-	11,250	9,000	7,500	6,429	5,625	5,000	4,500	4,091	3,750
700	700,000	567,000	-	13,000	10,500	8,750	7,500	6,563	5,833	5,250	4,773	4,375
800	800,000	648,000	-	14,500	12,000	10,000	8,571	7,500	6,667	6,000	5,455	5,000
840	1,050,000	850,500	-	-	-	13,000	11,250	9,844	8,750	7,875	7,159	6,562
960	1,200,000	972,000	-	-	-	14,500	12,857	11,250	10,000	9,000	8,182	7,500

① Ratings are shown for elevations up to 2000 feet. For higher elevations, refer to section "Considerations for Elevation" on page 10.

② Minimum Air Temperature Rise, Maximum Air Temperature Rise, and Maximum Discharge Air Temperature are as follows:

- For Model Sizes 75-400, Min Air Temp Rise is 20°F, Max Air Temp Rise is 100°F, and Max Discharge Air Temp is 150°F.
- For Model Sizes 500-800, Min Air Temp Rise is 40°F, Max Air Temp Rise is 120°F, and Max Discharge Air Temp is 150°F.
- For Model Sizes 840-960, Min Air Temp Rise is 60°F, Max Air Temp Rise is 120°F, and Max Discharge Air Temp is 150°F.
- Note that these are typical limits but may vary by Model Size. Refer to Table 27.1 for actual limits.

③ For Variable Air Movement Applications, see page 18.

Air Temperature Limits

The maximum allowable discharge air temperature is 150°F. The maximum allowable air temperature rise per furnace for Low Air Temperature Rise Units is 60°F. All system units are designed for a maximum allowable total static pressure of 3.0" W.C.

THIS PAGE INTENTIONALLY LEFT BLANK

THIS PAGE INTENTIONALLY LEFT BLANK

OPTION & ACCESSORY PRESSURE DROP DATA

Table 31.1 - Option & Accessory Pressure Drop Tables (in "W.C.") ①

Unit Size	Digit 16	CFM	Filters				Evap Cooler, 12" Media		Other			
			1" Permanent	2" Permanent	2" Farr Aeropleat	2" Farr 30/30	Without Pre-Filters	With Pre-Filters	Downturn Plenum	Rainhood and Birdscreen	Discharge Damper	
75	A, B, C, D	556	0.01	0.01	0.02	0.03	0.02	0.07	0.00	0.01	0.01	
		600	0.01	0.01	0.02	0.03	0.02	0.07	0.00	0.01	0.01	
		700	0.01	0.01	0.03	0.04	0.03	0.09	0.01	0.01	0.01	
		800	0.02	0.01	0.03	0.04	0.04	0.12	0.01	0.02	0.01	
		1,000	0.02	0.02	0.04	0.05	0.06	0.17	0.01	0.03	0.01	
		1,200	0.03	0.02	0.05	0.06	0.08	0.22	0.02	0.03	0.01	
		1,400	0.03	0.03	0.06	0.07	0.11	0.29	0.03	0.04	0.02	
		1,600	0.04	0.04	0.07	0.09	0.15	0.36	0.04	0.06	0.02	
		1,800	0.04	0.04	0.08	0.10	0.19	0.44	0.05	0.07	0.03	
		2,000	0.05	0.05	0.10	0.11	0.23	0.53	0.06	0.08	0.03	
		2,300	0.06	0.07	0.11	0.13	0.31	0.68	0.08	0.11	0.04	
		2,778	0.08	0.09	0.15	0.16	0.45	0.96	0.12	0.15	0.06	
100/125	C, D, E, F	741	0.01	0.02	0.02	0.02	0.02	0.08	0.00	0.03	0.01	
		1,000	0.02	0.02	0.03	0.04	0.04	0.12	0.01	0.05	0.01	
		1,500	0.03	0.04	0.05	0.07	0.08	0.23	0.02	0.07	0.02	
		2,000	0.05	0.06	0.07	0.10	0.15	0.36	0.04	0.10	0.03	
		2,500	0.07	0.08	0.10	0.14	0.23	0.53	0.07	0.13	0.04	
		3,000	0.09	0.11	0.13	0.19	0.34	0.73	0.11	0.16	0.05	
		3,500	0.11	0.13	0.16	0.24	0.46	0.97	0.15	0.19	0.07	
		4,000	0.14	0.16	0.20	0.30	0.60	1.23	0.19	0.22	0.09	
		4,500	0.17	0.20	0.25	0.37	4000 Max CFM for Evap		0.25	0.25	0.11	
		4,630	0.17	0.21	0.26	0.39			0.26	0.26	0.11	
		5,556	0.19	0.23	0.30	0.38	5200 Max CFM		0.26	0.33	0.13	
150/175	C, D, E, F	1,111	0.01	0.02	0.03	0.04	0.03	0.09	0.02	0.02	0.01	
		1,500	0.02	0.03	0.04	0.05	0.05	0.15	0.02	0.03	0.01	
		2,000	0.03	0.04	0.06	0.08	0.09	0.24	0.04	0.05	0.02	
		2,500	0.05	0.06	0.09	0.11	0.14	0.34	0.05	0.08	0.02	
		3,000	0.06	0.08	0.11	0.15	0.20	0.46	0.07	0.10	0.04	
		3,500	0.08	0.11	0.14	0.18	0.27	0.61	0.10	0.14	0.05	
		4,000	0.11	0.13	0.18	0.23	0.35	0.77	0.13	0.18	0.06	
		4,500	0.13	0.16	0.21	0.27	0.45	0.95	0.17	0.22	0.08	
		5,000	0.16	0.19	0.25	0.32	0.55	1.15	0.21	0.27	0.10	
		5,200	0.17	0.21	0.27	0.34	0.60	1.23	0.23	0.29	0.11	
		5,556	0.19	0.23	0.30	0.38	5200 Max CFM		0.26	0.33	0.13	
		6,000	0.21	0.26	0.34	0.43	6000 Max CFM		0.30	0.45	0.16	
200/225	C, D, E, F, G, H	1,481	0.01	0.02	0.03	0.03	0.04	0.12	0.02	0.03	0.01	
		2,000	0.01	0.02	0.04	0.04	0.07	0.19	0.03	0.05	0.01	
		2,500	0.02	0.04	0.05	0.06	0.10	0.27	0.04	0.08	0.02	
		3,000	0.03	0.05	0.07	0.08	0.15	0.36	0.06	0.10	0.04	
		3,500	0.03	0.06	0.09	0.10	0.20	0.47	0.09	0.14	0.05	
		4,000	0.05	0.08	0.11	0.12	0.27	0.60	0.11	0.18	0.06	
		4,500	0.06	0.10	0.13	0.15	0.34	0.73	0.14	0.22	0.08	
		5,000	0.07	0.11	0.16	0.18	0.42	0.89	0.18	0.27	0.10	
		5,500	0.09	0.14	0.19	0.21	0.50	1.05	0.21	0.32	0.12	
		6,000	0.11	0.16	0.22	0.25	0.60	1.23	0.26	0.38	0.14	
		6,500	0.13	0.18	0.25	0.28	6000 Max CFM		0.30	0.45	0.16	
		7,250	0.23	0.32	0.41	0.51	6500 Max CFM		0.27	0.37	0.23	
		11,111	0.36	0.38	0.43	0.47	10400 Max CFM		0.66	0.71	0.53	
250/300 500/600	E, F, G, H	1,852	0.03	0.02	0.05	0.05	0.05	0.15	0.02	0.07	0.02	
		2,000	0.03	0.03	0.05	0.06	0.06	0.17	0.02	0.08	0.02	
		2,500	0.04	0.04	0.07	0.09	0.09	0.24	0.03	0.09	0.03	
		3,000	0.05	0.06	0.10	0.11	0.13	0.32	0.04	0.12	0.04	
		3,500	0.07	0.08	0.12	0.15	0.17	0.41	0.06	0.14	0.06	
		4,000	0.08	0.10	0.15	0.18	0.23	0.52	0.08	0.16	0.07	
		4,500	0.10	0.13	0.18	0.22	0.29	0.64	0.10	0.19	0.09	
		5,500	0.14	0.19	0.25	0.31	0.43	0.91	0.15	0.25	0.13	
		6,500	0.19	0.26	0.34	0.42	0.60	1.23	0.21	0.31	0.18	
	I, J, K	1,925	0.02	0.01	0.03	0.03	0.02	0.08	0.02	0.07	0.02	
		3,000	0.03	0.03	0.05	0.05	0.05	0.15	0.04	0.12	0.04	
		4,000	0.05	0.05	0.08	0.09	0.09	0.23	0.08	0.16	0.07	
		5,000	0.08	0.08	0.11	0.12	0.14	0.34	0.12	0.22	0.11	
		6,000	0.11	0.11	0.15	0.16	0.20	0.46	0.18	0.28	0.16	
		7,000	0.15	0.15	0.19	0.21	0.27	0.61	0.25	0.35	0.21	
		8,000	0.19	0.20	0.24	0.27	0.35	0.77	0.33	0.42	0.28	
		9,000	0.24	0.25	0.30	0.33	0.45	0.95	0.42	0.51	0.35	
		10,400	0.32	0.33	0.38	0.42	0.60	1.23	0.57	0.64	0.47	
350/400 700/800 840/960	E, F, G, H	2,593	0.02	0.02	0.04	0.04	0.05	0.16	0.02	0.03	0.01	
		3,000	0.02	0.02	0.05	0.05	0.07	0.20	0.03	0.04	0.01	
		3,500	0.03	0.03	0.06	0.06	0.10	0.25	0.04	0.05	0.01	
		4,000	0.03	0.04	0.07	0.08	0.13	0.32	0.05	0.07	0.01	
		4,500	0.04	0.05	0.09	0.10	0.16	0.39	0.06	0.09	0.02	
		5,000	0.05	0.06	0.10	0.12	0.20	0.47	0.07	0.11	0.02	
		5,500	0.06	0.07	0.12	0.14	0.24	0.55	0.09	0.14	0.03	
		6,000	0.06	0.08	0.14	0.17	0.29	0.64	0.10	0.17	0.04	
		6,500	0.07	0.10	0.16	0.19	0.34	0.74	0.12	0.20	0.04	
		7,000	0.08	0.11	0.18	0.22	0.39	0.85	0.14	0.23	0.05	
		I, J, K	2,593	0.02	0.01	0.02	0.02	0.03	0.11	0.02	0.03	0.01
			3,000	0.02	0.02	0.02	0.03	0.04	0.14	0.03	0.04	0.01
	4,000		0.03	0.03	0.04	0.04	0.08	0.22	0.05	0.07	0.01	
	5,000		0.04	0.04	0.05	0.06	0.12	0.31	0.07	0.11	0.02	
	6,000		0.06	0.05	0.07	0.08	0.18	0.42	0.10	0.17	0.04	
	7,000		0.07	0.07	0.10	0.11	0.24	0.55	0.14	0.23	0.05	
	8,000		0.09	0.09	0.12	0.13	0.32	0.70	0.19	0.30	0.08	
	9,000		0.11	0.12	0.15	0.16	0.40	0.86	0.24	0.38	0.10	
	10,000		0.13	0.14	0.18	0.19	0.50	1.04	0.30	0.48	0.14	
	11,050		0.15	0.17	0.22	0.23	0.61	1.24	0.36	0.58	0.17	
	12,000		0.18	0.20	0.26	0.27	11050 Max CFM		0.43	0.69	0.21	
	12,500		0.19	0.22	0.28	0.29			0.47	0.75	0.23	
	13,000	0.20	0.24	0.30	0.31			0.51	0.81	0.26		

① Accessory / Option static pressure losses are approximate values only. Please consult the Accuspec selection software for static pressure losses at other than listed CFM.

BLOWER PERFORMANCE DATA

Table 32.1 - Unit Performance Tables ①②

Unit Size	Digit 16	Air Temp. Rise	CFM	Total Static Pressure, "W.C.																			
				0.25		0.50		0.75		1.00		1.25		1.50		2.00		2.50		3.00			
				BHP	RPM	BHP	RPM	BHP	RPM	BHP	RPM	BHP	RPM	BHP	RPM	BHP	RPM	BHP	RPM	BHP	RPM		
75	A,B	100°F / -	556	0.09	679	0.15	871	0.22	1031	0.29	1170	0.37	1296	0.45	1411	0.63	1617	0.81	1800	1.01	1968		
		79°F / -	700	0.14	747	0.21	924	0.29	1074	0.37	1206	0.46	1327	0.55	1438	0.75	1638	0.95	1818	1.17	1982		
		69°F / -	800	0.18	801	0.26	966	0.35	1109	0.44	1237	0.54	1354	0.64	1462	0.84	1658	1.06	1832	1.30	1996		
		56°F / -	1000	0.29	917	0.39	1062	0.50	1192	0.60	1310	0.72	1419	0.83	1522	1.07	1709	1.32	1879	-	-		
		46°F / -	1200	0.45	1042	0.57	1171	0.69	1289	0.82	1397	0.94	1499	1.08	1595	1.35	1773	-	-	-	-		
		40°F / -	1400	0.66	1173	0.80	1288	0.94	1395	1.08	1495	1.23	1589	1.38	1680	-	-	-	-	-	-		
		35°F / -	1600	0.93	1308	1.09	1412	1.25	1509	1.42	1601	-	-	-	-	-	-	-	-	-	-		
31°F / -	1800	1.28	1445	1.46	1539	-	-	-	-	-	-	-	-	-	-	-	-	-	-				
75	C,D	69°F / -	800	-	-	0.15	795	0.21	960	-	-	-	-	-	-	-	-	-	-	-			
		56°F / -	1000	-	-	0.20	822	0.28	975	0.36	1112	-	-	-	-	-	-	-	-	-			
		46°F / -	1200	0.19	705	0.27	862	0.35	1003	0.44	1131	0.54	1250	0.65	1361	-	-	-	-	-			
		40°F / -	1400	0.27	770	0.36	912	0.45	1041	0.55	1161	0.66	1273	0.77	1377	1.00	1572	-	-	-			
		35°F / -	1600	0.37	839	0.47	968	0.57	1087	0.68	1199	0.80	1304	0.92	1403	1.17	1589	1.44	1760	1.72	1920		
		31°F / -	1800	0.49	912	0.60	1030	0.72	1139	0.84	1244	0.96	1343	1.09	1437	1.36	1613	1.65	1777	1.94	1931		
		28°F / -	2000	0.65	987	0.77	1095	0.90	1197	1.03	1295	1.16	1388	1.30	1477	1.59	1645	1.89	1802	2.20	1950		
		24°F / -	2300	0.94	1104	1.08	1200	1.22	1292	1.37	1380	1.52	1465	1.67	1547	1.98	1703	2.31	1850	2.65	1990		
		20°F / -	2778	1.59	1296	1.75	1377	1.92	1456	2.09	1532	2.26	1606	2.44	1679	2.80	1818	-	-	-	-		
		100/125	C,D	100°F / -	741	-	-	0.15	808	0.23	962	0.30	1093	0.38	1212	0.47	1320	0.60	1514	0.86	1686	1.07	1840
				80°F / 100°F	926	0.13	670	0.21	846	0.29	993	0.38	1121	0.47	1236	0.56	1342	0.77	1532	0.99	1702	1.22	1856
62°F / 77°F	1200			0.22	758	0.31	916	0.41	1052	0.52	1173	0.62	1282	0.74	1384	0.97	1568	1.22	1733	1.48	1884		
53°F / 66°F	1400			0.30	828	0.41	975	0.53	1103	0.64	1218	0.76	1323	0.89	1422	1.15	1600	1.42	1762	1.70	1910		
41°F / 51°F	1800			0.55	982	0.69	1108	0.83	1220	0.98	1325	1.12	1422	1.27	1513	1.58	1681	1.90	1834	2.23	1976		
34°F / 42°F	2200			0.93	1145	1.10	1254	1.27	1354	1.44	1449	1.61	1537	1.79	1621	2.15	1778	2.52	1923	2.90	2057		
28°F / 36°F	2600			1.45	1315	1.65	1410	1.85	1500	2.05	1585	2.25	1666	2.46	1744	1.35	1638	-	-	-	-		
25°F / 31°F	3000			2.16	1489	2.39	1573	2.61	1654	2.84	1731	-	-	-	-	-	-	-	-	-			
41°F / 51°F	1800			0.28	497	0.41	622	0.56	735	0.72	837	-	-	-	-	-	-	-	-	-			
34°F / 42°F	2200			0.43	553	0.58	662	0.75	762	0.93	855	1.12	942	1.33	1025	-	-	-	-	-			
28°F / 36°F	2600			0.63	614	0.81	710	1.00	800	1.20	885	1.41	965	1.63	1042	-	-	-	-	-			
25°F / 31°F	3000			0.91	680	1.11	766	1.32	847	1.54	1731	1.77	997	2.01	1068	2.51	1202	3.04	1328	3.60	1446		
22°F / 27°F	3400			1.26	748	1.48	825	1.72	899	1.96	970	2.21	1038	2.47	1104	3.01	1229	3.58	1347	4.17	1459		
20°F / 25°F	3704			1.58	802	1.83	873	2.08	942	2.34	1008	2.60	1072	2.88	1135	3.45	1254	4.04	1367	4.67	1474		
- / 23°F	4100	2.09	873	2.35	938	2.63	1001	2.91	1062	3.20	1122	3.49	1180	4.10	1291	4.74	1398	-	-				
- / 20°F	4630	2.93	969	3.23	1028	3.53	1085	3.84	1140	4.16	1194	4.48	1247	-	-	-	-	-					
150/175	C,D	100°F / 117°F	1111	0.19	727	0.28	884	0.38	1023	0.48	1148	0.59	1262	0.70	1369	0.94	1563	1.21	1738	1.48	1899		
		86°F / 100°F	1296	0.27	793	0.37	937	0.47	1066	0.59	1184	0.71	1293	0.83	1395	1.09	1582	1.37	1752	1.66	1909		
		79°F / 93°F	1400	0.32	832	0.42	970	0.54	1093	0.66	1208	0.78	1313	0.91	1412	1.18	1596	1.47	1763	1.78	1917		
		62°F / 72°F	1800	0.59	994	0.72	1109	0.86	1216	1.00	1316	1.15	1410	1.30	1500	1.62	1667	1.95	1823	2.29	1967		
		51°F / 59°F	2200	1.00	1166	1.16	1264	1.32	1356	1.49	1444	1.66	1529	1.84	1610	2.20	1762	2.57	1906	2.96	2041		
		43°F / 50°F	2600	1.58	1344	1.76	1429	1.95	1510	2.14	1589	2.34	1664	2.54	1737	2.95	1877	-	-	-			
		37°F / 43°F	3000	2.35	1526	2.57	1600	2.78	1673	3.00	1743	-	-	-	-	-	-	-	-				
		86°F / 100°F	1296	-	-	0.25	609	0.37	734	-	-	-	-	-	-	-	-	-	-	-			
		79°F / 93°F	1400	0.17	474	0.28	615	0.40	737	-	-	-	-	-	-	-	-	-	-				
150/175	E,F	62°F / 72°F	1800	0.28	526	0.41	650	0.55	760	0.70	859	0.85	952	-	-	-	-	-	-				
		51°F / 59°F	2200	0.44	588	0.59	697	0.75	796	0.91	887	1.09	972	1.27	1052	1.67	1201	-	-				
		43°F / 50°F	2600	0.67	657	0.83	753	1.01	842	1.19	925	1.39	1004	1.59	1078	2.02	1218	2.47	1348	2.96	1469		
		37°F / 43°F	3000	0.96	729	1.15	815	1.35	895	1.55	972	1.76	1044	1.98	1114	2.45	1245	2.94	1368	3.45	1483		
		33°F / 38°F	3400	1.35	804	1.55	881	1.77	955	2.00	1025	2.23	1092	2.47	1157	2.96	1280	3.49	1396	4.03	1505		
		29°F / 34°F	3800	1.82	880	2.05	951	2.29	1018	2.53	1083	2.79	1146	3.04	1206	3.58	1322	4.14	1431	4.72	1535		
		26°F / 31°F	4200	2.40	959	2.66	1023	2.92	1085	3.18	1145	3.45	1204	3.73	1260	4.30	1369	4.90	1472	-	-		
		24°F / 28°F	4700	3.30	1058	3.58	1116	3.87	1172	4.16	1227	4.46	1281	4.76	1333	-	-	-	-				
		21°F / 25°F	5200	4.40	1158	4.71	1212	-	-	-	-	-	-	-	-	-	-	-	-				
		200/225	C,D	100°F / 113°F	1481	0.36	871	0.48	1016	0.60	1144	0.73	1259	0.85	1366	0.99	1465	1.26	1646	1.54	1808	1.84	1958
89°F / 100°F	1667			0.48	943	0.61	1078	0.75	1198	0.88	1309	1.03	1411	1.17	1507	1.47	1682	1.77	1842	2.09	1988		
85°F / 95°F	1750			0.54	975	0.68	1106	0.82	1224	0.96	1332	1.11	1433	1.26	1527	1.57	1700	1.88	1857	2.21	2003		
74°F / 83°F	2000			0.76	1077	0.92	1197	1.08	1306	1.24	1407	1.40	1502	1.57	1592	1.91	1758	2.26	1910	2.62	2051		
66°F / 74°F	2250			1.04	1181	1.21	1291	1.39	1393	1.57	1488	1.75	1577	1.94	1663	2.31	1822	2.69	1969	-	-		
59°F / 67°F	2500			1.38	1288	1.57	1389	1.77	1484	1.97	1573	2.17	1658	2.37	1739	2.78	1892	-	-	-			
54°F / 61°F	2750			1.79	1396	2.00	1490	2.22	1579	2.44	1663	2.66	1743	2.88	1820	-	-	-	-				
49°F / 56°F	3000			2.28	1506	2.51	1593	2.75	1677	2.98	1756	-	-	-	-	-	-	-	-				
200/225	E,F			85°F / 95°F	1750	0.29	594	0.43	723	0.58	838	0.75	944	0.94	1042	1.14	1134	1.58	1303	2.07	1458	2.60	1600
				74°F / 83°F	2000	0.40	642	0.54	759	0.71	866	0.88	966	1.08	1058	1.28	1146	1.74	1309	2.23	1458	2.78	1595
		59°F / 67°F	2500	0.68	746	0.85	84																

BLOWER PERFORMANCE DATA

Table 33.1 - Unit Performance Tables ①②

Unit Size	Digit 16	Air Temp. Rise	CFM	Total Static Pressure, "W.C.																			
				0.25		0.50		0.75		1.00		1.25		1.50		2.00		2.50		3.00			
				BHP	RPM	BHP	RPM	BHP	RPM	BHP	RPM	BHP	RPM	BHP	RPM	BHP	RPM	BHP	RPM	BHP	RPM		
250/300 Start 300	E,F	100°F / 120°F	1852	0.26	532	0.39	665	0.54	782	0.69	887	0.85	985	1.03	1074	1.39	1239	1.79	1387	2.21	1523		
		83°F / 100°F	2222	0.39	582	0.54	703	0.70	810	0.87	909	1.05	1000	1.24	1085	1.64	1242	2.06	1385	2.52	1517		
		74°F / 89°F	2500	0.51	625	0.68	736	0.85	836	1.04	930	1.23	1016	1.43	1099	1.85	1250	2.30	1389	2.78	1517		
		62°F / 74°F	3000	0.80	706	0.99	803	1.19	893	1.40	978	1.62	1058	1.84	1133	2.31	1275	2.81	1406	3.33	1529		
		53°F / 63°F	3500	1.19	793	1.41	878	1.64	959	1.87	1036	2.12	1109	2.36	1179	2.88	1312	3.42	1435	3.99	1552		
		46°F / 56°F	4000	1.69	882	1.94	958	2.20	1032	2.46	1102	2.73	1170	3.01	1234	3.58	1358	4.17	1474	4.78	1584		
		41°F / 49°F	4500	2.34	974	2.62	1043	2.90	1109	3.19	1174	3.49	1236	3.79	1296	4.41	1412	-	-	-	-		
		37°F / 44°F	5000	3.14	1067	3.44	1130	3.76	1191	4.08	1250	4.40	1308	4.73	1364	-	-	-	-	-	-		
		34°F / 40°F	5500	4.11	1161	4.44	1219	4.78	1275	-	-	-	-	-	-	-	-	-	-	-	-		
		250/300 Start 300	G,H	100°F / 120°F	1852	-	-	0.34	519	0.49	623	0.66	713	0.85	795	1.05	870	1.47	1005	1.94	1126	2.44	1237
83°F / 100°F	2222			0.28	424	0.43	537	0.61	634	0.79	721	0.99	800	1.20	872	1.65	1005	2.14	1123	2.67	1231		
74°F / 89°F	2500			0.35	447	0.52	553	0.71	646	0.90	730	1.11	806	1.33	877	1.81	1006	2.32	1123	2.87	1230		
62°F / 74°F	3000			0.53	492	0.72	588	0.93	674	1.15	752	1.38	824	1.62	892	2.13	1016	2.68	1129	3.27	1232		
53°F / 63°F	3500			0.76	542	0.98	628	1.21	707	1.45	780	1.71	848	1.97	912	2.52	1031	3.11	1140	3.74	1240		
46°F / 56°F	4000			1.07	594	1.31	673	1.57	746	1.83	814	2.11	878	2.39	939	2.99	1052	3.62	1156	4.28	1253		
41°F / 49°F	4500			1.45	649	1.72	721	2.00	789	2.29	852	2.59	912	2.90	969	3.54	1077	4.22	1177	4.92	1270		
37°F / 44°F	5000			1.92	706	2.22	771	2.52	834	2.84	894	3.16	950	3.50	1004	4.18	1107	4.90	1202	-	-		
34°F / 40°F	5500			2.50	767	2.81	824	3.14	882	3.49	938	3.83	991	4.19	1042	4.93	1140	-	-	-	-		
31°F / 37°F	6000			3.16	822	3.52	878	3.87	933	4.24	984	4.61	1035	5.00	1084	-	-	-	-	-	-		
250/300 End 250	I, J, K	46°F / 56°F	4000	-	-	0.97	507	1.25	583	1.56	654	1.89	719	2.24	781	-	-	-	-	-	-		
		37°F / 44°F	5000	-	-	1.51	560	1.84	626	2.19	688	2.56	748	2.95	804	3.77	908	4.67	1005	-	-		
		31°F / 37°F	6000	1.94	559	2.29	620	2.66	679	3.06	734	3.46	787	3.89	838	4.79	935	5.75	1025	6.77	1110		
		26°F / 32°F	7000	2.93	632	3.33	686	3.75	738	4.19	788	4.64	836	5.11	882	6.09	971	7.13	1055	8.22	1134		
		23°F / 28°F	8000	4.24	707	4.69	755	5.16	802	5.64	847	6.14	891	6.65	933	7.72	1015	8.83	1093	10.00	1167		
		20°F / 24°F	9259	6.40	804	6.91	846	7.45	887	7.99	927	8.55	966	9.12	1004	10.30	1079	11.52	1150	12.79	1218		
		- / 22°F	10000	7.97	862	8.52	901	9.09	939	9.67	977	10.27	1014	10.87	1050	12.12	1120	13.41	1187	14.74	1252		
		- / 20°F	11111	10.79	949	11.40	985	12.03	1020	12.66	1054	13.31	1087	13.97	1121	-	-	-	-	-	-		
		350/400 Start 400	E,F	100°F / -	2593	0.61	668	0.80	781	1.01	882	1.22	975	1.45	1061	1.69	1142	2.19	1290	2.73	1425	3.30	1550
				96°F / -	2700	0.67	686	0.87	796	1.08	895	1.30	986	1.53	1071	1.78	1151	2.29	1297	2.84	1431	3.42	1555
87°F / 100°F	2963			0.85	730	1.06	834	1.28	928	1.52	1015	1.76	1097	2.02	1174	2.56	1316	3.13	1446	3.74	1568		
74°F / 85°F	3500			1.30	826	1.54	917	1.80	1002	2.07	1081	2.34	1157	2.62	1228	3.22	1362	3.84	1486	4.50	1602		
65°F / 74°F	4000			1.86	918	2.13	1000	2.42	1078	2.71	1151	3.01	1221	3.32	1288	3.97	1414	4.65	1531	-	-		
58°F / 66°F	4500			2.57	1012	2.87	1087	3.18	1158	3.51	1226	3.84	1291	4.18	1353	4.88	1472	-	-	-	-		
52°F / 59°F	5000			3.44	1109	3.78	1177	4.12	1242	4.47	1305	4.84	1366	-	-	-	-	-	-	-	-		
47°F / 54°F	5500			4.50	1206	4.87	1269	-	-	-	-	-	-	-	-	-	-	-	-	-	-		
350/400 Start 400	G,H			100°F / -	2593	0.43	479	0.62	585	0.84	679	1.09	764	1.35	841	1.64	1142	2.26	1046	2.94	1165	3.68	1275
				87°F / 100°F	2963	0.57	516	0.79	614	1.02	702	1.28	782	1.56	856	1.86	926	2.50	1053	3.20	1170	3.96	1277
		74°F / 85°F	3500	0.85	574	1.09	662	1.35	742	1.63	815	1.93	885	2.25	951	2.93	1072	3.66	1183	4.45	1287		
		65°F / 74°F	4000	1.19	631	1.45	710	1.74	784	2.04	853	2.36	918	2.70	980	3.41	1096	4.19	1202	-	-		
		58°F / 66°F	4500	1.61	690	1.91	762	2.22	830	2.55	895	2.89	956	3.25	1014	4.00	1124	4.81	1226	-	-		
		52°F / 59°F	5000	2.22	767	2.46	817	2.80	880	3.15	940	3.52	998	3.90	1053	4.70	1157	-	-	-	-		
		47°F / 54°F	5500	2.77	813	3.12	874	3.49	933	3.87	989	4.25	1042	4.66	1095	-	-	-	-	-	-		
		43°F / 49°F	6000	3.53	876	3.91	933	4.30	987	4.70	1040	-	-	-	-	-	-	-	-	-	-		
		40°F / 46°F	6500	4.42	939	4.82	992	-	-	-	-	-	-	-	-	-	-	-	-	-	-		
		350/400 Start 400	I,J,K	100°F / -	2593	-	-	-	0.77	561	1.04	639	1.34	709	1.66	774	2.36	891	3.14	995	4.00	1090	
87°F / 100°F	2963			-	-	-	0.89	571	1.18	646	1.49	715	1.81	779	2.54	894	3.34	997	4.20	1091			
65°F / 74°F	4000			-	-	1.07	533	1.37	609	1.69	679	2.03	742	2.40	802	3.18	910	4.04	1009	4.96	1099		
52°F / 59°F	5000			1.37	515	1.69	590	2.04	658	2.41	721	2.79	779	3.19	835	4.05	937	4.98	1030	5.96	1117		
43°F / 49°F	6000			2.20	588	2.58	654	2.97	715	3.39	772	3.82	826	4.26	877	5.20	973	6.21	1061	7.26	1144		
37°F / 42°F	7000			3.34	665	3.77	723	4.22	778	4.68	830	5.16	879	5.65	927	6.68	1016	7.77	1099	8.90	1178		
32°F / 37°F	8000			4.84	744	5.33	796	5.83	845	6.34	893	6.87	938	7.41	982	8.53	1066	9.70	1144	10.92	1219		
29°F / 33°F	9000			6.75	824	7.29	871	7.85	917	8.41	960	8.99	1002	9.58	1043	10.80	1121	12.07	1194	13.37	1265		
26°F / 30°F	10000			9.13	906	9.72	948	10.33	990	10.95	1030	11.58	1069	12.22	1107	13.54	1180	14.90	1249	-	-		
24°F / 27°F	11000			12.01	988	12.66	1027	13.32	1065	14.00	1103	14.68	1139	-	-	-	-	-	-	-	-		
23°F / 26°F	11500	13.66	12.09	14.34	1067	-	-	-	-	-	-	-	-	-	-	-	-	-	-				

① Total static pressure should include external static pressure and accessory / option static pressure from Table 31.1. Unit internal resistance has been included in the unit performance tables.
 ② Brake Horsepower and RPM values are approximate values only. Please consult the AccuSpec selection software for values at other than listed CFM / static pressures.

BLOWER PERFORMANCE DATA

Table 34.1 - Unit Performance Tables ①②

Unit Size	Digit 16	Air Temp Rise	CFM	Total Static Pressure Inches "W.C.																	
				0.25		0.50		0.75		1.00		1.25		1.50		2.00		2.50		3.00	
				BHP	RPM	BHP	RPM	BHP	RPM	BHP	RPM	BHP	RPM	BHP	RPM	BHP	RPM	BHP	RPM	BHP	RPM
500/600 Start 600	G or H →	120°F / -	3086	0.62	529	0.82	620	1.03	703	1.26	779	1.50	849	1.75	916	2.28	1038	2.84	1149	3.44	1252
		106°F / -	3500	0.84	575	1.06	658	1.30	736	1.54	807	1.80	874	2.07	937	2.63	1054	3.23	1162	3.86	1262
		100°F / 120°F	3704	0.97	598	1.20	678	1.45	753	1.70	822	1.97	887	2.25	949	2.83	1064	3.44	1170	4.09	1268
		93°F / 111°F	4000	1.18	633	1.43	709	1.69	779	1.96	846	2.24	908	2.53	968	3.14	1080	3.78	1183	4.45	1279
		82°F / 99°F	4500	1.61	693	1.88	762	2.17	827	2.46	889	2.77	948	3.09	1001	3.74	1110	4.43	1208	-	-
		74°F / 89°F	5000	2.13	755	2.43	818	2.75	878	3.07	936	3.40	991	3.74	1044	4.44	1145	-	-	-	-
		67°F / 81°F	5500	2.77	818	3.10	876	3.44	932	3.79	986	4.15	1038	4.51	1088	-	-	-	-	-	-
		62°F / 74°F	6000	3.53	882	3.89	936	4.25	988	4.63	1038	-	-	-	-	-	-	-	-	-	-
500/600 Start 600	I, J, K →	120°F / -	3086	0.46	401	0.69	496	0.95	580	1.23	657	-	-	-	-	-	-	-	-	-	-
		100°F / 120°F	3704	0.69	443	0.95	527	1.23	604	1.54	675	-	-	-	-	-	-	-	-	-	-
		93°F / 111°F	4000	0.82	464	1.09	544	1.39	618	1.71	686	2.05	749	2.42	810	-	-	-	-	-	-
		74°F / 89°F	5000	1.43	542	1.75	609	2.09	673	2.46	733	2.84	790	3.24	844	4.09	946	5.01	1041	-	-
		62°F / 74°F	6000	2.31	624	2.68	682	3.07	738	3.48	791	3.91	842	4.35	891	5.29	984	6.28	1072	7.33	1155
		53°F / 63°F	7000	3.51	709	3.94	760	4.38	809	4.84	857	5.31	903	5.80	947	6.82	1032	7.90	1113	9.03	1191
		46°F / 56°F	8000	5.09	797	5.57	842	6.07	886	6.58	928	7.10	970	7.64	1010	8.75	1089	9.92	1163	11.13	1235
		41°F / 49°F	9000	7.11	885	7.65	926	8.20	965	8.76	1001	9.33	1042	9.92	1079	11.13	1151	12.38	1220	13.69	1287
500/600 Start 500	L →	- / 44°F	10000	9.62	975	10.21	1012	10.81	1048	11.43	1083	12.05	1118	12.69	1152	14.00	1218	15.35	1283	-	-
		- / 43°F	10400	10.77	1011	11.38	1046	12.01	1081	12.64	1115	13.29	1149	13.95	1182	15.30	1247	-	-	-	-
		- / 40°F	11000	12.66	1065	13.31	1099	13.97	1132	14.64	1164	15.32	1197	16.01	1228	17.42	1290	-	-	-	-
		- / 40°F	11111	13.04	1075	13.69	1109	14.36	1141	15.03	1174	15.72	1205	16.41	1237	17.83	1298	-	-	-	-
		62°F / 74°F	6000	1.69	512	1.97	565	2.26	616	2.57	664	2.89	710	3.23	755	-	-	-	-	-	-
		53°F / 63°F	7000	2.57	580	2.89	626	3.22	671	3.56	714	3.92	756	4.29	797	5.06	874	-	-	-	-
		46°F / 56°F	8000	3.73	650	4.09	691	4.46	731	4.84	770	5.23	808	5.64	845	6.47	916	7.35	984	-	-
		41°F / 49°F	9000	5.21	721	5.60	758	6.01	795	6.43	830	6.86	864	7.30	898	8.21	964	9.16	1027	10.14	1088
700/800 Start 800	G or H →	- / 44°F	10000	7.04	793	7.48	827	7.93	860	8.39	892	8.85	924	9.33	955	10.31	1016	11.33	1074	12.38	1131
		- / 43°F	10400	7.88	823	8.34	855	8.80	887	9.28	918	9.76	949	10.25	979	11.26	1038	12.31	1095	13.38	1150
		- / 40°F	11000	9.27	866	9.75	897	10.24	927	10.74	957	11.24	986	11.76	1015	12.81	1071	13.90	1126	-	-
		- / 40°F	11111	9.54	874	10.03	905	10.52	935	11.02	964	11.53	993	12.05	1022	13.12	1078	14.21	1132	-	-
		120°F / -	4321	1.51	685	1.80	760	2.11	830	2.43	896	2.77	958	3.13	1018	3.88	1131	4.69	1236	-	-
		115°F / -	4500	1.68	708	1.98	780	2.30	847	2.63	912	2.98	973	3.34	1032	4.11	1142	4.94	1245	-	-
		105°F / 120°F	4938	2.15	763	2.48	89	2.82	893	3.17	953	3.54	1011	3.93	1066	4.74	1172	-	-	-	-
		104°F / 119°F	5000	2.23	770	2.55	836	2.90	899	3.26	959	3.63	1016	4.02	1072	4.83	1176	-	-	-	-
700/800 Start 800	I, J, K →	94°F / 108°F	5500	2.89	834	3.25	895	3.62	953	4.00	1009	4.40	1063	4.81	1116	-	-	-	-	-	-
		86°F / 99°F	6000	3.68	900	4.06	956	4.46	1010	4.87	1062	-	-	-	-	-	-	-	-	-	-
		80°F / 91°F	6500	4.61	965	-	-	-	-	-	-	-	-	-	-	-	-	-	-	-	-
		120°F / -	4321	0.87	443	1.14	421	1.42	591	1.72	657	2.04	717	2.37	774	3.08	879	3.84	974	4.65	1063
		104°F / 119°F	5000	1.26	488	1.55	558	1.87	623	2.20	683	2.54	740	2.90	794	3.66	894	4.47	985	5.33	1071
		86°F / 99°F	6000	2.02	558	2.36	619	2.73	677	3.10	731	3.49	782	3.89	832	4.73	924	5.62	1010	6.55	1091
		65°F / 74°F	8000	4.44	707	4.89	755	5.35	801	5.82	845	6.30	888	6.79	930	7.81	1009	8.87	1085	9.96	1156
		58°F / 66°F	9000	6.19	784	6.69	827	7.20	869	7.72	909	8.25	949	8.79	987	9.90	1061	11.04	1131	12.23	1199
700/800 Start 800	L →	52°F / 59°F	10000	8.36	861	8.91	901	9.47	939	10.04	976	10.62	1012	11.21	1048	12.42	1117	13.66	1183	14.93	1246
		47°F / 54°F	11000	11.00	940	11.60	976	12.22	1011	12.84	1045	13.47	1079	14.11	1112	15.41	1176	16.74	1238	-	-
		43°F / 49°F	12000	14.16	1019	14.81	1052	15.48	1085	16.15	1117	16.83	1148	17.52	1179	18.92	1239	-	-	-	-
		40°F / 46°F	13000	17.88	1098	18.59	1129	19.30	1159	-	-	-	-	-	-	-	-	-	-	-	-
		65°F / 74°F	8000	3.26	566	3.60	611	3.95	654	4.31	696	4.67	736	5.05	774	5.84	848	6.66	918	7.51	984
		58°F / 66°F	9000	4.54	626	4.92	667	5.30	706	5.70	744	6.10	780	6.52	816	7.37	885	8.25	950	9.17	1012
		52°F / 59°F	10000	6.13	687	6.54	724	6.97	760	7.40	794	7.85	828	8.30	861	9.22	925	10.17	987	11.15	1046
		47°F / 54°F	11000	8.06	749	8.52	782	8.98	815	9.45	847	9.93	879	10.42	910	11.41	969	12.43	1027	13.48	1083
End 700	→	47°F / 54°F	11050	8.17	752	8.62	785	9.09	818	9.56	850	10.04	881	10.53	912	11.53	972	12.56	1029	13.61	1084
		43°F / 49°F	12000	10.37	811	10.86	842	11.37	872	11.88	902	12.40	931	12.92	960	13.99	1016	15.08	1070	16.20	1123
		40°F / 46°F	13000	13.09	873	13.63	902	14.17	930	14.72	958	15.27	986	15.83	1013	16.98	1065	18.14	1116	19.33	1166
		- / 42°F	14000	16.26	936	16.83	963	17.41	989	18.00	1015	18.59	1041	19.19	1066	-	-	-	-	-	-
		- / 41°F	14500	18.02	968	18.61	994	19.21	1019	19.82	1045	-	-	-	-	-	-	-	-	-	-
		120°F / -	6481	2.72	630	3.09	685	3.48	736	3.88	785	4.30	832	4.72	876	5.60	960	6.52	1038	7.48	1112
		111°F / -	7000	3.36	672	3.76	723	4.17	772	4.60	818	5.04	863	5.49	905	6.42	986	7.38	1061	8.39	1133
		105°F / 120°F	7407	3.93	705	4.35	754	4.79	800	5.23	845	5.69	888	6.16	929	7.13	1007	8.13	1081	9.17	1151
840/960 End 840	→	97°F / 111°F	8000	4.87	754	5.33	799	5.90	843	6.27	885	6.76	926	7.26	965	8.28	1040	9.33	1111	10.43	1179
		86°F / 99°F	9000	6.80	837	7.31	878	7.83	918	8.36	956	8.90	994	9.44	1030	10.56	1100	11.71	1166	12.90	1230
		78°F / 89°F	10000	9.20	921	9.76	958	10.33	995	10.91	1030	11.50	1065	12.10	1099	13.32	1164	14.56	1226	-	-
		70°F / 80°F	11050	12.28	1010	12.89	1044	13.52	1078	14.16	1110	14.80	1142	15.45	1173	16.77	1234	-	-	-	-
		65°F / 74°F	12000	15.60	1091	16.27	1123	16.95	1154	17.63	1184	18.32	1214	19.02	1243	-	-	-	-	-	-
		62°F / 71°F	12500	17.58	1134	18.27	1164	18.97	1194	19.69	1224	-	-	-	-	-	-				

BLOWER SHEAVE ASSEMBLY DATA

Adjusting the Blower Drive Setting

Based on the Sheave Arrangement, Tables 35.1 through 36.5 give the Sheave Assembly numbers used on units that include a blower. The Sheave Arrangement is Digit 19 and is found on the unit Model Identification Plate. The Sheave Assembly describes the motor and blower sheave size and bore as well as the belt provided.

To determine how many turns open the motor sheave should be set for:

1. From Table 31.1, determine the individual static pressure drops for any features included on the unit. Add those and the design external static pressure to calculate the total

2. Locate the unit Model Identification Plate and note Digit 16 and Digit 19 of the model number. Digit 16 is the Blower Size and Type and Digit 19 is the Sheave Arrangement.
3. Once the Blower Size and Type (Digit 16) is known, enter the proper Sheave Arrangement table.
4. Use the Sheave Arrangement (Digit 19) to determine the Sheave Assembly provided.
5. Use Table 37.1 and the Sheave Assembly number to determine the required turns open to achieve the desired blower rpm.
6. Set the motor sheave as described in Blower Adjustments.

Figure 35.1 - Blower Section

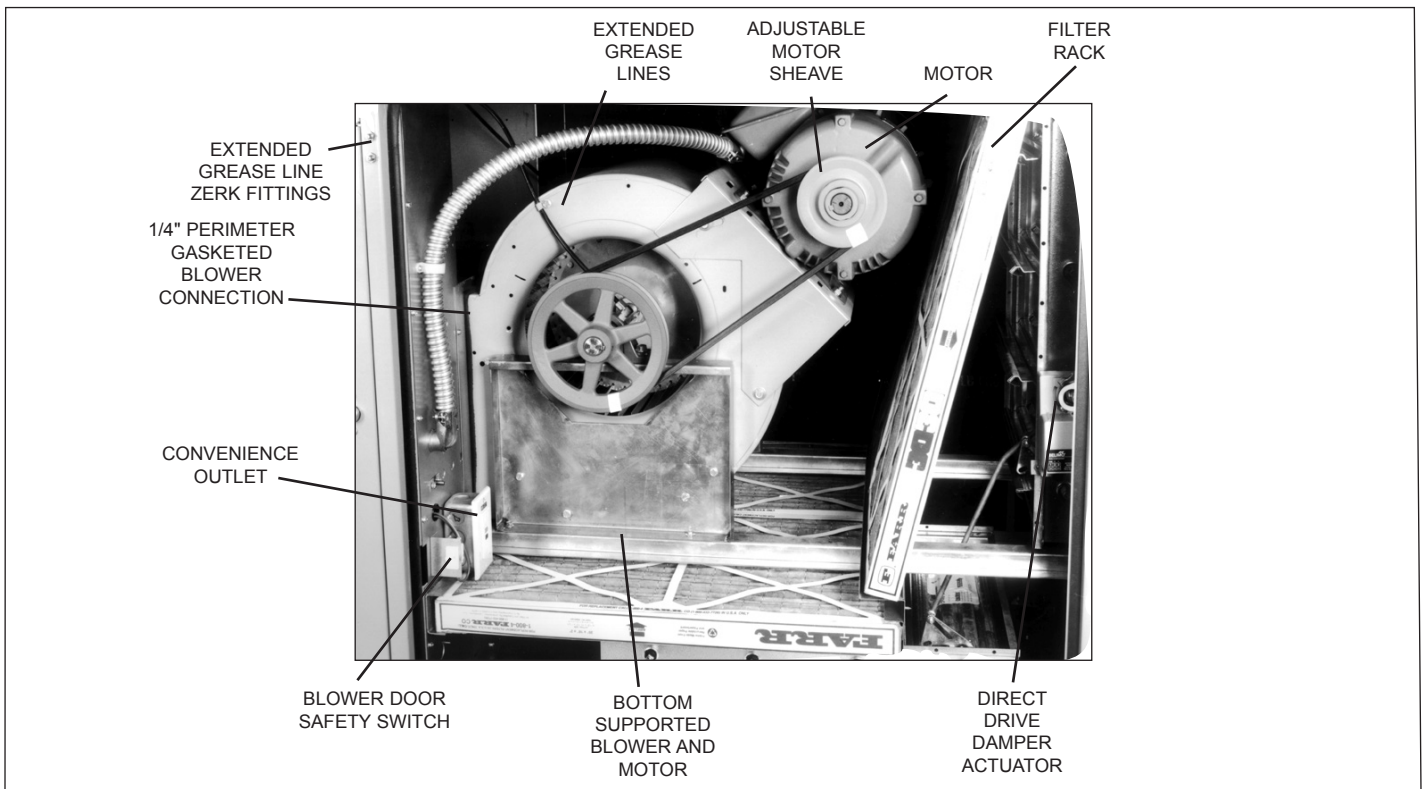

Blower Sheave Assembly Numbers

Table 35.1 - Digit 16 = A or B (9-7 Blower Units)

Motor Frame	RPM Range									
	656-1001		978-1265		1150-1561		1526-1858		1763-2147	
Size	Digit 19	Sheave Assembly	Digit 19	Sheave Assembly	Digit 19	Sheave Assembly	Digit 19	Sheave Assembly	Digit 19	Sheave Assembly
48	A	3H35125B1	C	3H35125B3						
56	B	3H35125B2	D	3H35125B4	F	3H35125B6	H	3H35125B8	J	3H35125B10
143 or 145			E	3H35125B5	G	3H35125B7	I	3H35125B9	K	3H35125B11

Table 35.2 - Digit 16 = C or D (9-9 Blower Units)

Motor Frame	RPM Range									
	656-1001		978-1265		1150-1561		1526-1858		1763-2147	
Size	Digit 19	Sheave Assembly	Digit 19	Sheave Assembly	Digit 19	Sheave Assembly	Digit 19	Sheave Assembly	Digit 19	Sheave Assembly
48	A	3H35126B1	C	3H35126B3						
56	B	3H35126B2	D	3H35126B4	F	3H35126B6	I	3H35126B9	L	3H35126B12
143 or 145			E	3H35126B5	G	3H35126B7	J	3H35126B10	M	3H35126B13
182 or 184					H	3H35126B8	K	3H35126B11	N	3H35126B14

BLOWER SHEAVE ASSEMBLY DATA

Blower Sheave Assembly Numbers (Con't)

Table 36.1 - Digit 16 = E or F (12-12 Blower Units)

Motor Frame	RPM Range											
	468-715		644-874		863-1078		1029-1332		1150-1438		1327-1659	
Size	Digit 19	Sheave Assembly	Digit 19	Sheave Assembly	Digit 19	Sheave Assembly	Digit 19	Sheave Assembly	Digit 19	Sheave Assembly	Digit 19	Sheave Assembly
48	A	3H35127B1										
56	B	3H35127B2	C	3H35127B3	F	3H35127B6	Q	3H35127B17				
143 to 145			D	3H35127B4	G	3H35127B7	I	3H35127B9	L	3H35127B12		
182 or 184			E	3H35127B5	H	3H35127B8	J	3H35127B10	M	3H35127B13	O	3H35127B15
213 or 215							K	3H35127B11	N	3H35127B14	P	3H35127B16

Table 36.2 - Digit 16 = G or H (15-15 Blower Units)

Motor Frame	RPM Range									
	410-625		568-771		767-958		934-1136		1136-1380	
Size	Digit 19	Sheave Assembly	Digit 19	Sheave Assembly	Digit 19	Sheave Assembly	Digit 19	Sheave Assembly	Digit 19	Sheave Assembly
48	A	3H35128B1								
56	B	3H35128B2	D	3H35128B4	G	3H35128B7	O	3H35128B15		
143 to 145	C	3H35128B3	E	3H35128B5	H	3H35128B8	J	3H35128B10		
182 or 184			F	3H35128B6	I	3H35128B9	K	3H35128B11	M	3H35128B13
213 or 215							L	3H35128B12	N	3H35128B14

Table 36.3 - Digit 16 = I or J (18-18 Blower Units under 15 Hp motor)

Motor Frame	RPM Range											
	491-649		586-744		682-821		821-1009		995-1161		1101-1285	
Size	Digit 19	Sheave Assembly	Digit 19	Sheave Assembly	Digit 19	Sheave Assembly	Digit 19	Sheave Assembly	Digit 19	Sheave Assembly	Digit 19	Sheave Assembly
56	A	3H35129B1	D	3H35129B4								
143 or 145	B	3H35129B2	E	3H35129B5	H	3H35129B8						
182 to 184	C	3H35129B3	F	3H35129B6	I	3H35129B9	K	3H35129B11	O	3H35129B15		
213 or 215			G	3H35129B7	J	3H35129B10	L	3H35129B12	P	3H35129B16	S	3H35129B19
254							M	3H35129B13	Q	3H35129B17	T	3H35129B20
256							N	3H35129B14	R	3H35129B18	U	3H35129B21

Table 36.4 - Digit 16 = K (18-18 Blower Units with 15 Hp motor & up)

Motor Frame	RPM Range							
	826-1009		995-1161		1101-1285		1232-1438	
Size	Digit 19	Sheave Assembly	Digit 19	Sheave Assembly	Digit 19	Sheave Assembly	Digit 19	Sheave Assembly
254	A	3H35130B1	C	3H35130B3	E	3H35130B5		
256	B	3H35130B2	D	3H35130B4	F	3H35130B6		
284	G	3H35130B13	I	3H35130B15	K	3H35130B17	M	3H35130B19
286	H	3H35130B14	J	3H35130B16	L	3H35130B18	N	3H35130B20

Table 36.5 - Digit 16 = L (20-18 Blower Units)

Motor Frame	RPM Range											
	491-649		626-765		765-901		901-1059		995-1161		1101-1285	
Size	Digit 19	Sheave Assembly	Digit 19	Sheave Assembly	Digit 19	Sheave Assembly	Digit 19	Sheave Assembly	Digit 19	Sheave Assembly	Digit 19	Sheave Assembly
143 or 145	A	3H36622B1	C	3H36622B3								
182 to 184	B	3H36622B2	D	3H36622B4	F	3H36622B6	L	3H36622B12				
213 or 215			E	3H36622B5	G	3H36622B7	M	3H36622B13	R	3H36622B18		
254					H	3H36622B8	N	3H36622B14	S	3H36622B19	W	3H36622B23
256					I	3H36622B9	O	3H36622B15	T	3H36622B20	X	3H36622B24
284					J	3H36622B10	P	3H36622B16	U	3H36622B21	Y	3H36622B25
286					K	3H36622B11	Q	3H36622B17	V	3H36622B22	Z	3H36622B26

BLOWER SHEAVE ASSEMBLY DATA

Table 37.1 - Blower Sheave Assembly Settings

Sheave Assembly	Turns Open										
	0	0.5	1	1.5	2	2.5	3	3.5	4	4.5	5
	Blower RPM										
3H35125B1-2	1001	966	932	897	863	828	794	759	725	690	656
3H35125B3-5	1265	1236	1208	1179	1150	1121	1093	1064	1035	1006	978
3H35125B6-7	1561	1520	1479	1438	1396	1355	1314	1273	1232	1191	1150
3H35125B8-9	1858	1825	1791	1758	1725	1692	1659	1625	1592	1559	1526
3H35125B10-11	2147	2108	2070	2032	1993	1955	1917	1878	1840	1802	1763
3H35126B1-2	1001	966	932	897	863	828	794	759	725	690	656
3H35126B3-5	1265	1236	1208	1179	1150	1121	1093	1064	1035	1006	978
3H35126B6-8	1561	1520	1479	1438	1396	1355	1314	1273	1232	1191	1150
3H35126B9-11	1858	1825	1791	1758	1725	1692	1659	1625	1592	1559	1526
3H35126B12-14	2147	2108	2070	2032	1993	1955	1917	1878	1840	1802	1763
3H35127B1-2	715	690	665	641	616	591	567	542	518	493	468
3H35127B3-5	874	851	828	805	782	759	736	713	690	667	644
3H35127B6-8	1078	1057	1035	1013	992	970	949	927	906	884	863
3H35127B9-11	1332	1301	1271	1241	1211	1180	1150	1120	1089	1059	1029
3H35127B12-14	1438	1409	1380	1351	1323	1294	1265	1236	1208	1179	1150
3H35127B15-16	1659	1625	1592	1559	1526	1493	1460	1426	1393	1360	1327
3H35127B17	1332	1301	1271	1241	1211	1180	1150	1120	1089	1059	1029
3H35128B1-3	625	604	582	561	539	518	496	474	453	431	410
3H35128B4-6	771	751	731	710	690	670	649	629	609	589	568
3H35128B7-9	958	939	920	901	882	863	843	824	805	786	767
3H35128B10-12	1136	1116	1096	1076	1055	1035	1015	994	974	954	934
3H35128B13-14	1380	1355	1331	1306	1281	1257	1232	1208	1183	1158	1136
3H35128B15	1136	1116	1096	1076	1055	1035	1015	994	974	954	934
3H35129B1-3	649	633	617	601	586	570	554	538	522	506	491
3H35129B4-7	744	728	712	696	681	665	649	633	617	601	586
3H35129B8-10	821	807	793	779	765	751	737	723	709	696	682
3H35129B11-14	1009	991	973	954	936	918	899	881	863	844	821
3H35129B15-18	1161	1144	1128	1111	1095	1078	1062	1045	1028	1012	995
3H35129B19-21	1285	1266	1248	1230	1211	1193	1174	1156	1138	1119	1101
3H35130B1-2	1009	991	973	954	936	918	899	881	863	844	826
3H35130B3-4	1161	1144	1128	1111	1095	1078	1062	1045	1028	1012	995
3H35130B5-6	1285	1266	1248	1230	1211	1193	1174	1156	1138	1119	1101
3H35130B13-14	974	960	946	932	918	904	890	876	863	849	835
3H35130B15-16	1161	1144	1128	1111	1095	1078	1062	1045	1028	1012	995
3H35130B17-18	1285	1266	1248	1230	1211	1193	1174	1156	1138	1119	1101
3H35130B19-20	1438	1417	1396	1376	1355	1335	1314	1294	1273	1253	1232
3H36622B1-2	649	633	617	601	586	570	554	538	522	506	491
3H36622B3-5	765	751	737	723	709	696	682	668	654	640	626
3H36622B6-11	901	888	875	863	850	837	824	811	798	785	765
3H36622B12-17	1059	1044	1029	1014	999	984	968	953	938	923	901
3H36622B18-22	1161	1144	1128	1111	1095	1078	1062	1045	1028	1012	995
3H36622B23-26	1285	1266	1248	1230	1211	1193	1174	1156	1138	1119	1101

BLOWER SHEAVE ASSEMBLY DATA

Table 38.1 - Blower Sheave Assembly Components

Sheave Assembly		Browning Belt #	Motor Sheave		Blower Sheave	
Prefix	Suffix		Pitch Dia (in.)	Bore (in.)	Pitch Dia (in.)	Bore (in.)
3H35125	1	A30	2.9	0.5	5	0.75
	2	A31	2.9	0.625		
	3	A34	4.4	0.5		
	4	A35	4.4	0.625	6	
	5	A35	4.4	0.875		
	6	A31	3.8	0.625	4.2	
	7	A31	3.8	0.875		
	8	A35	5.6	0.625	5.2	
	9	A35	5.6	0.875		
	10	A34	5.6	0.625	4.5	
	11	A34	5.6	0.875		
3H35126	1	A33	2.9	0.5	5	0.75
	2	A34	2.9	0.625		
	3	A37	4.4	0.5	6	
	4	A38	4.4	0.625		
	5	A38	4.4	0.875		
	6	A34	3.8	0.625	4.2	
	7	A34	3.8	0.875		
	8	A36	3.8	1.125	5.2	
	9	A38	5.6	0.625		
	10	A38	5.6	0.875	4.5	
	11	A40	5.6	1.125		
	12	A37	5.6	0.625		
	13	A37	5.6	0.875		
	14	A39	5.6	1.125		
3H35127	1	A42	2.9	0.5	7	1
	2	A43	2.9	0.625		
	3	A46	3.8	0.625	7.5	
	4	A45	3.8	0.875		
	5	A47	3.8	1.125		
	6	A48	5	0.625	8	
	7	A48	5	0.875		
	8	A50	5	1.125	5.7	
	9	A43	4.4	0.875		
	10	A45	4.4	1.125	6.7	
	11	A49	5.2	1.375		
	12	A45	5	0.875	6	
	13	A47	5	1.125		
	14	A49	5.2	1.375	6.2	
	15	A45	5	1.125		
	16	A48	5.6	1.375	5.7	
	17	A43	4.4	0.625		
3H35128	1	A47	2.9	0.5	8	1
	2	A48	2.9	0.625		
	3	A48	2.9	0.875		
	4	A50	3.8	0.625	8.5	
	5	A50	3.8	0.875		
	6	A52	3.8	1.125		
	7	A53	5	0.625	9	
	8	A52	5	0.875		
	9	A54	5	1.125	8.5	
	10	A53	5.6	0.875		
	11	A54	5.6	1.125	8	
	12	A54	5.2	1.375		
	13	A52	5.6	1.125	7	
	14	A52	5.2	1.375		
	15	A53	5.6	0.625	8.5	

Sheave Assembly		Browning Belt #	Motor Sheave		Blower Sheave	
Prefix	Suffix		Pitch Dia (in.)	Bore (in.)	Pitch Dia (in.)	Bore (in.)
3H35129	1	B71	4.1	0.625	10.9	1
	2	B71	4.1	0.875		
	3	B70	4.1	1.125		
	4	BX71	4.7	0.625		
	5	BX71	4.7	0.875		
	6	BX71	4.7	1.125		
	7	BX71	5.5	1.375	12.4	
	8	BX77	5.9	0.875		
	9	BX75	5.9	1.125		
	10	BX75	5.9	1.375		
	11	BX68	5.3	1.125		
	12	BX68	5.5	1.375	9.4	
	13	BX75	5.5	1.625		
	14	BX75	5.5	1.625		
	15	B73	7	1.125	10.4	
	16	B72	7	1.375		
	17	B78	7	1.625		
	18	B78	7	1.625		
	19	B70	7	1.375	9.4	
	20	B77	7	1.625		
	21	B77	7	1.625		
3H35130	1	Qty (2) B74	5.5	1.625	9.4	1.44
	2	Qty (2) B74	5.5	1.625		
	3	Qty (2) B78	7	1.625	10.4	
	4	Qty (2) B78	7	1.625		
	5	Qty (2) B77	7	1.625	9.4	
	6	Qty (2) B77	7	1.625		
	13	Qty (2) B82	7	1.875	12.4	
	14	Qty (2) B82	7	1.875		
	15	Qty (2) B79	7	1.875	10.4	
	16	Qty (2) B79	7	1.875		
17	Qty (2) B77	7	1.875	9.4		
18	Qty (2) B77	7	1.875			
19	Qty (2) B75	7	1.875	8.4		
20	Qty (2) B75	7	1.875			
3H36622	1	B75	4.1	0.875	10.9	1.44
	2	BX73	4.1	1.125		
	3	B72	4.1	0.875	8.9	
	4	B70	4.1	1.125		
	5	BX78	5.5	1.375	12.4	
	6	B74	4.7	1.125		
	7	BX75	5.5	1.375	10.4	
	8	Qty (2) BX82	6	1.625		
	9	Qty (2) BX82	6	1.625	11.4	
	10	Qty (2) B86	7	1.875		
	11	Qty (2) B86	7	1.875	13.4	
	12	B71	5.3	1.125		
	13	BX74	5.9	1.375	8.4	
	14	Qty (2) BX79	6	1.625		
	15	Qty (2) BX79	6	1.625	9.4	
	16	Qty (2) B83	7	1.875		
	17	Qty (2) B83	7	1.875		
	18	B77	7	1.375	11.4	
	19	Qty (2) B82	7	1.625		
	20	Qty (2) B82	7	1.625	10.4	
	21	Qty (2) B81	7	1.875		
	22	Qty (2) B81	7	1.875		
	23	Qty (2) B80	7	1.625	9.4	
	24	Qty (2) B80	7	1.625		
	25	Qty (2) B80	7	1.875		
	26	Qty (2) B80	7	1.875		

THIS PAGE INTENTIONALLY LEFT BLANK

DIMENSIONS - UNIT

Figure 40.1 - HBP Outdoor STANDARD Blower Package Unit Dimensions

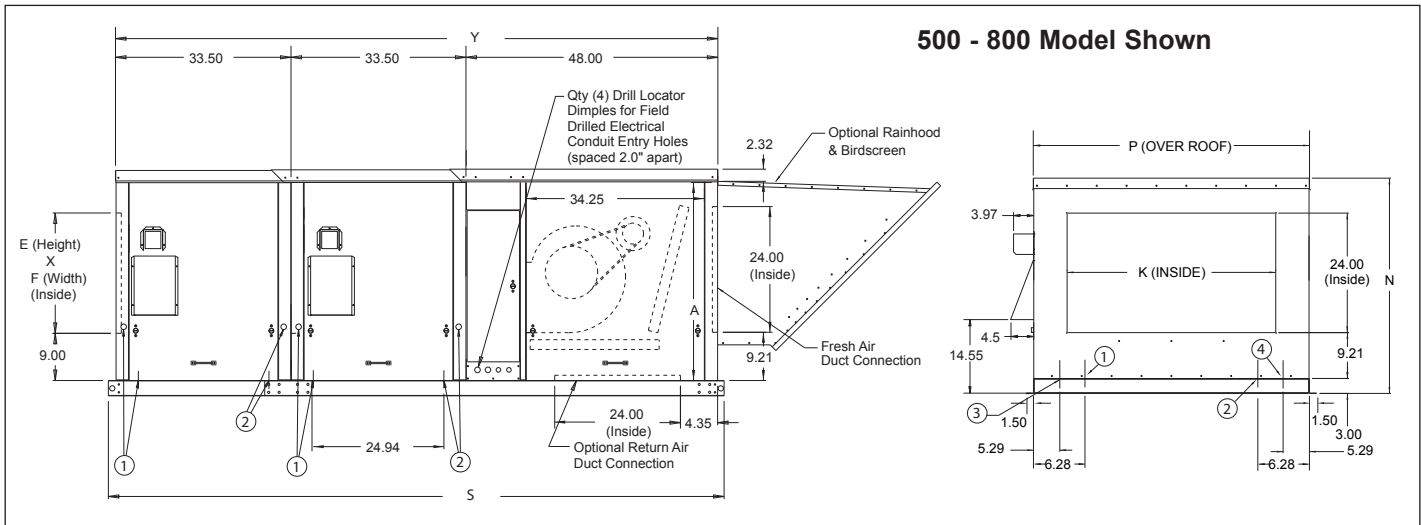

Figure 40.2 - HDP Outdoor STANDARD Blower Downturn Package Unit Dimensions

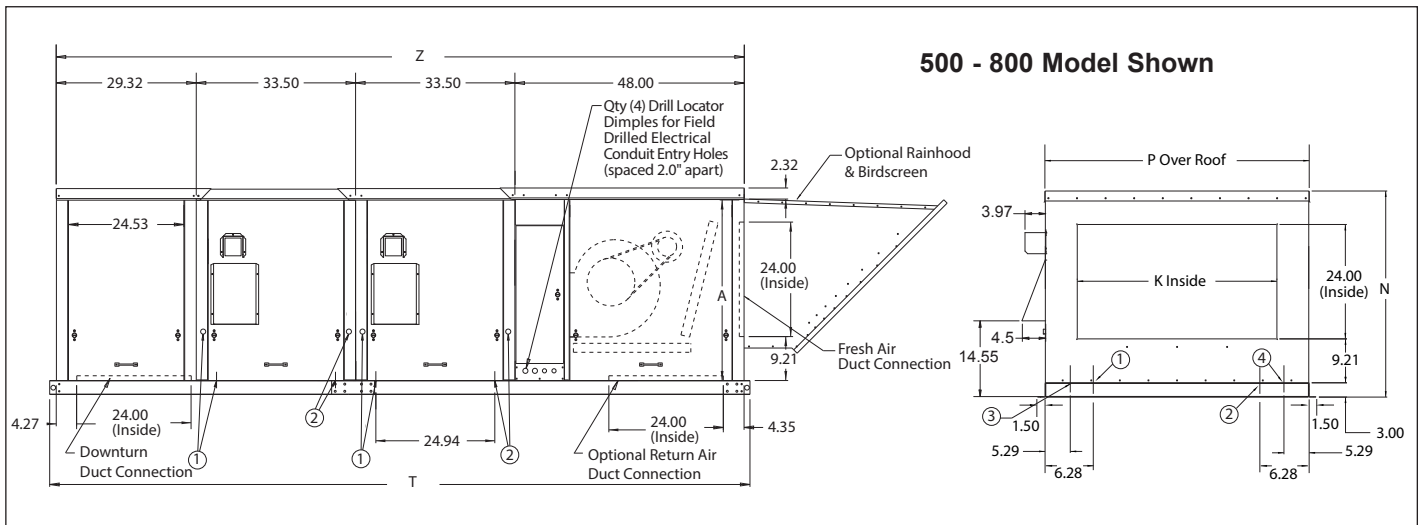

Table 40.1 - HBP/HDP Outdoor STANDARD Blower Unit Dimensions

Model Size	Blower Type (Digit 16)	Furnace Qty	Dimensions (inches)										Gas Conn.
			A	E	F	K	N	P	S	T	Y	Z	
75	All	1	33.75	18.98	15.18	20.02	39.23	32.06	84.41	108.39	81.49	110.82	1/2
100/125	All	1	33.75	18.98	17.69	20.02	39.23	34.56	84.41	108.39	81.49	110.82	1/2
150/175	All	1	33.75	18.98	21.94	23.99	39.23	38.82	84.41	108.39	81.49	110.82	1/2
200/225	All	1	37.75	22.98	24.06	23.99	43.23	40.94	84.41	108.39	81.49	110.82	1/2
250/300	E, F, G, or H	1	37.75	22.98	27.09	29.96	43.23	44.05	84.41	108.39	81.49	110.82	3/4
350/400	E, F, G, or H	1	37.75	22.98	38.60	41.90	43.23	55.57	84.41	108.39	81.49	110.82	3/4
500/600	G or H	2	37.75	22.98	27.09	29.96	43.23	44.05	117.53	146.77	114.94	144.12	3/4
700/800	G or H	2	37.75	22.98	38.60	41.90	43.23	55.57	117.53	146.77	114.94	144.12	3/4

- ① For Right Hand Access Units - Location of drill locator dimples for field drilled gas connection entry holes - one side of unit and one on bottom.
- ② For Left Hand Access Units - Location of drill locator dimples for field drilled gas connection entry holes - one side of unit and one on bottom.
- ③ For Right Hand Access Units - Location of drill locator dimples for field drilled electrical connection, entry holes identical as side electrical connections.
- ④ For Left Hand Access Units - Location of drill locator dimples for field drilled electrical connection, entry holes identical as side electrical connections.

DIMENSIONS - UNIT

Figure 41.1 - HBP Outdoor EXTENDED Blower Package Unit Dimensions (Blower Type I, J, K, or L)

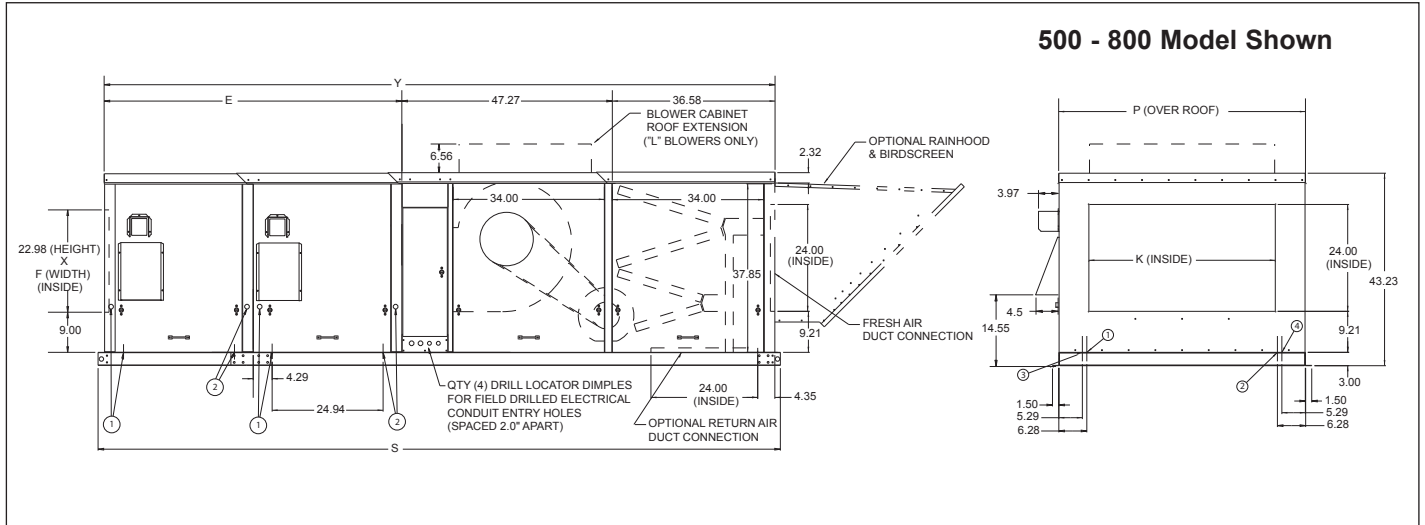

Figure 41.2 - HDP Outdoor EXTENDED Blower Downturn Package Unit Dimensions (Blower Type I, J, K, or L)

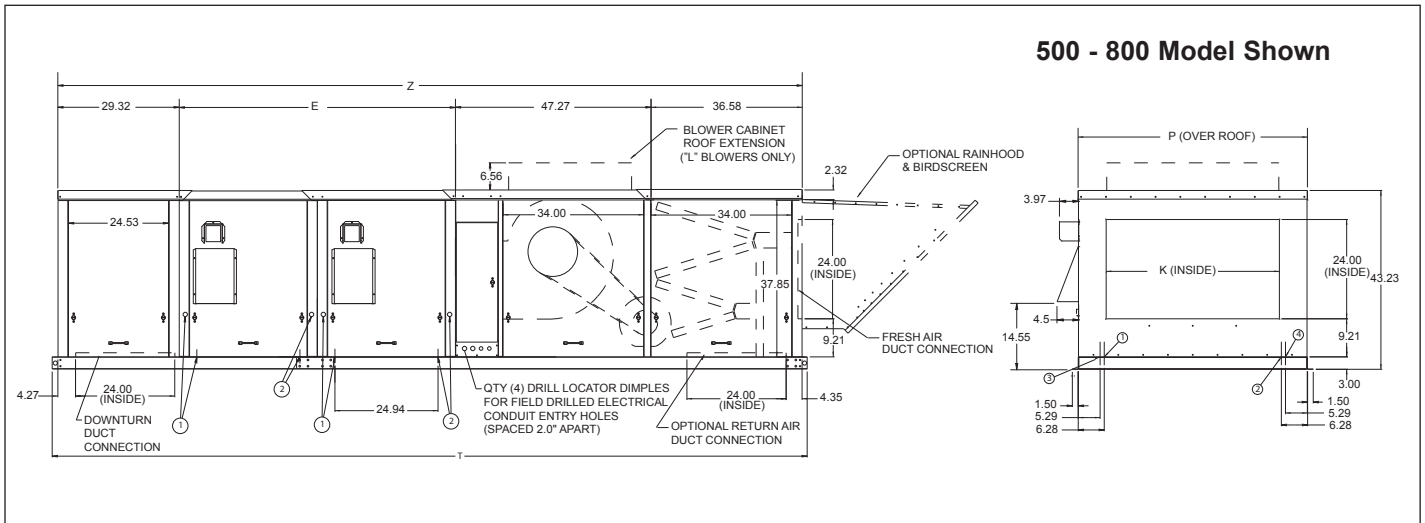

Table 41.1 - HBP/HDP Outdoor EXTENDED Blower Unit Dimensions (Blower Type I, J, K, or L)

Model Size	Blower Type (Digit 16)	Furnace Qty	Dimensions (inches)								Gas Conn.
			E	F	K	P	S	T	Y	Z	
250/300	I, J, or K	1	33.50	27.09	29.96	44.05	120.00	141.34	117.34	141.34	3/4
350/400	I, J, or K	1	33.50	38.60	41.90	55.57	120.00	141.34	117.34	141.34	3/4
500/600	I, J, K, or L	2	67.00	27.09	29.96	44.05	153.12	182.36	150.74	180.00	3/4
700/800	I, J, K, or L	2	67.00	38.60	41.90	55.57	153.12	182.36	150.74	180.00	3/4
840/960	I, J, K, or L	3	100.50	38.60	41.90	55.57	186.52	215.77	184.14	213.40	3/4

- ① For Right Hand Access Units - Location of drill locator dimples for field drilled gas connection entry holes - one side of unit and one on bottom.
- ② For Left Hand Access Units - Location of drill locator dimples for field drilled gas connection entry holes - one side of unit and one on bottom.
- ③ For Right Hand Access Units - Location of drill locator dimples for field drilled electrical connection, entry holes identical as side electrical connections.
- ④ For Left Hand Access Units - Location of drill locator dimples for field drilled electrical connection, entry holes identical as side electrical connections.

DIMENSIONS - UNIT

Figure 42.1 - HCP Outdoor STANDARD BLOWER Cooling Package Unit Dimensions

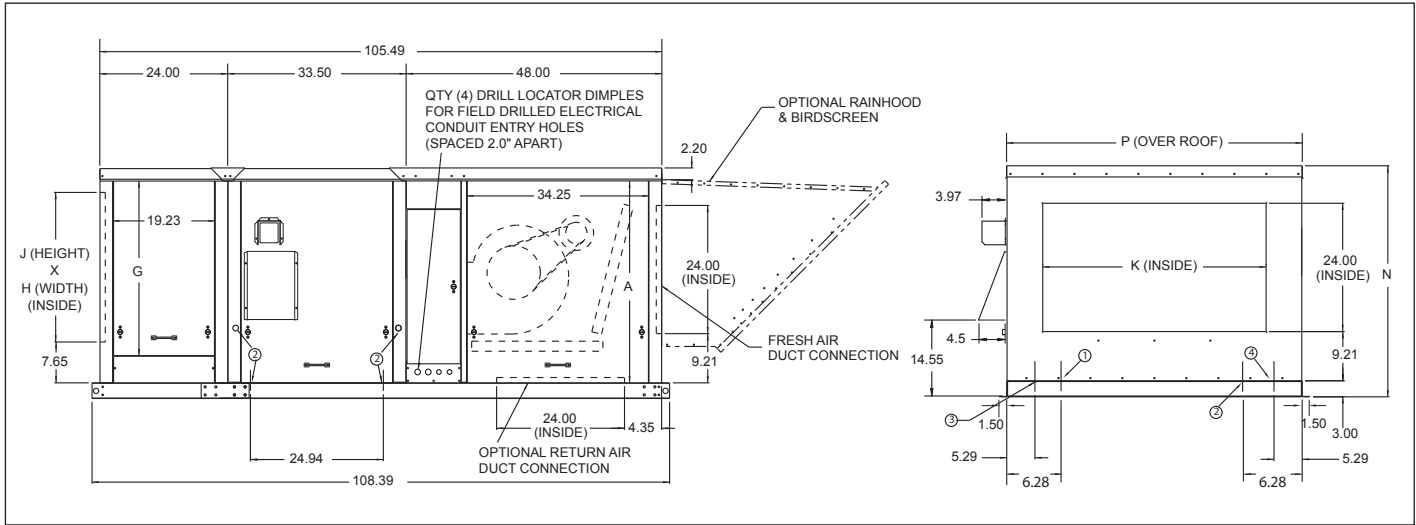

Figure 42.2 - HPP Outdoor STANDARD BLOWER Cooling & Downturn Packaged Unit Dimensions

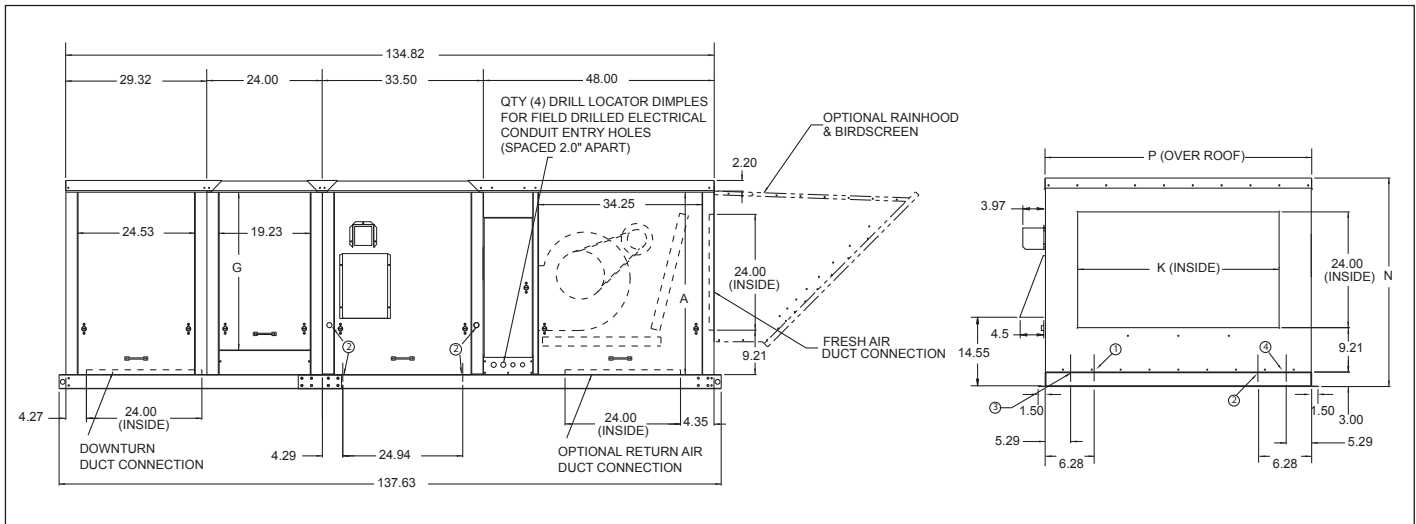

Table 43.1 - HCP/HPP Outdoor STANDARD Blower Unit Dimensions

Model Size	Blower Type (Digit 16)	Dimensions (inches)							Gas Conn.
		A	G	H	J	K	N	P	
75	All	33.75	28.75	18.00	25.00	20.02	39.23	32.06	1/2
100/125	All	33.75	28.75	21.00	25.00	20.02	39.23	34.56	1/2
150/175	All	33.75	28.75	24.00	25.00	23.99	39.23	38.82	1/2
200/225	All	37.75	32.75	27.00	28.00	23.99	43.23	40.94	1/2
250/300	E, F, G, or H	37.75	32.75	30.00	28.00	29.96	43.23	44.05	3/4
350/400	E, F, G, or H	37.75	32.75	42.00	28.00	41.90	43.23	55.57	3/4

- ① For Right Hand Access Units - Location of drill locator dimples for field drilled gas connection entry holes - one side of unit and one on bottom.
- ② For Left Hand Access Units - Location of drill locator dimples for field drilled gas connection entry holes - one side of unit and one on bottom.
- ③ For Right Hand Access Units - Location of drill locator dimples for field drilled electrical connection, entry holes identical as side electrical connections.
- ④ For Left Hand Access Units - Location of drill locator dimples for field drilled electrical connection, entry holes identical as side electrical connections.

DIMENSIONS - UNIT

Figure 43.1 - HCP Outdoor EXTENDED Blower Cooling Package Unit Dimensions (Blower Type I, J, or K)

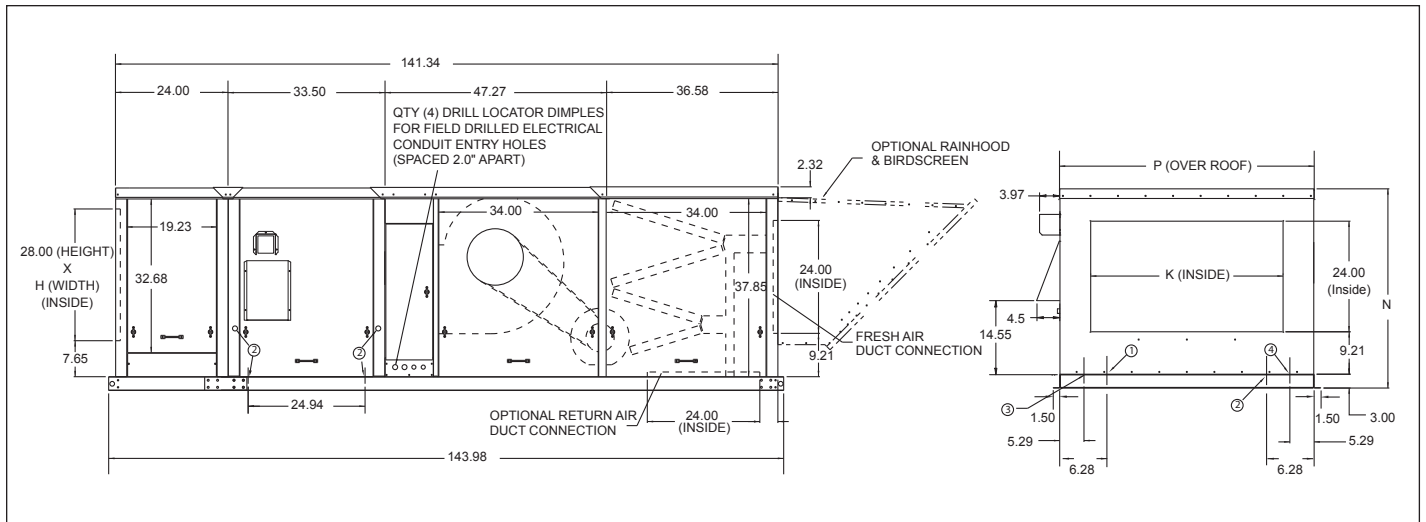

Figure 43.2 - HPP Outdoor EXTENDED Blower Cooling & Downturn Unit Dimensions (Blower Type I, J or K)

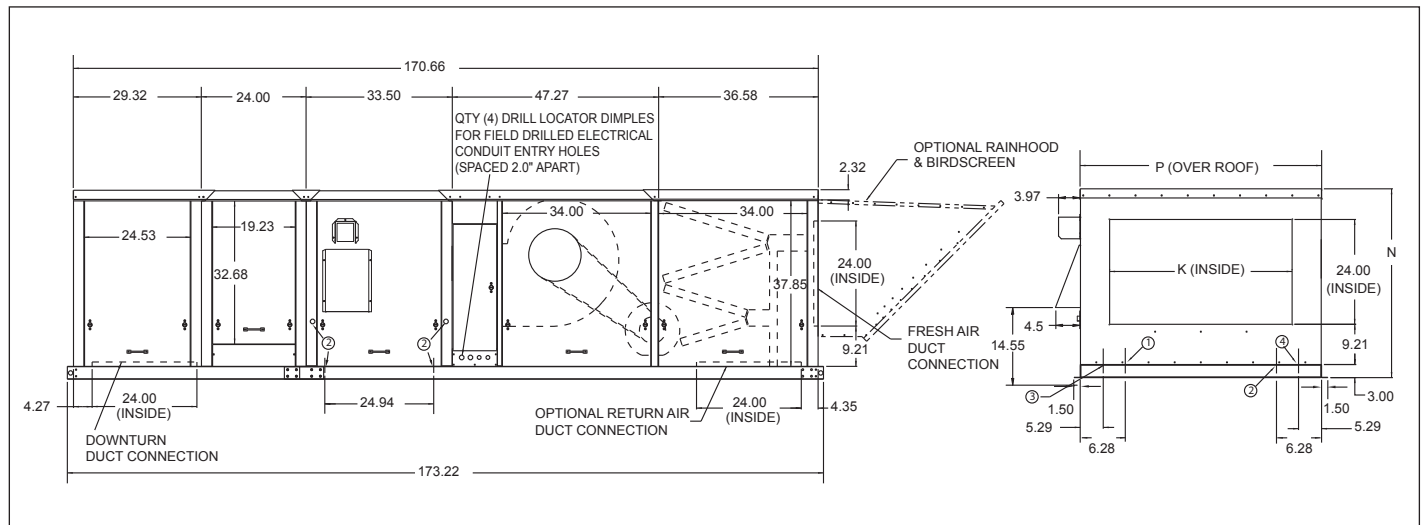

Table 43.1 - HCP/HPP Outdoor EXTENDED Blower Unit Dimensions

Model Size	Blower Type (Digit 16)	Dimensions (inches)					Gas Conn.
		F	H	K	N	P	
250/300	I, J, or K	27.09	30.00	29.96	43.23	44.05	3/4
350/400	I, J, or K	38.60	42.00	41.90	43.23	55.57	3/4

- ① For Right Hand Access Units - Location of drill locator dimples for field drilled gas connection entry holes - one side of unit and one on bottom.
- ② For Left Hand Access Units - Location of drill locator dimples for field drilled gas connection entry holes - one side of unit and one on bottom.
- ③ For Right Hand Access Units - Location of drill locator dimples for field drilled electrical connection, entry holes identical as side electrical connections.
- ④ For Left Hand Access Units - Location of drill locator dimples for field drilled electrical connection, entry holes identical as side electrical connections.

THIS PAGE INTENTIONALLY LEFT BLANK

DIMENSIONS - UNIT BASE

Figure 45.1 - Unit Base Dimensions

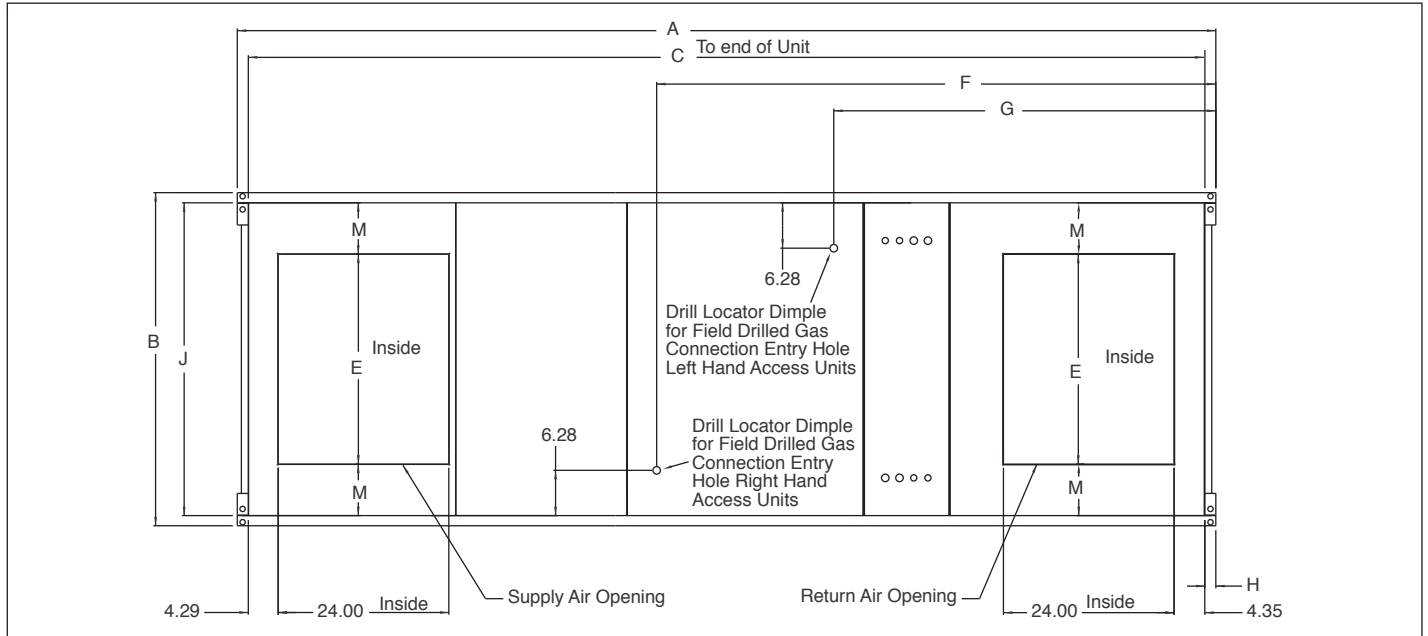

Table 45.1 - HBP & HDP Outdoor Unit Base Rail Dimensions (All dimensions in inches)

Model Size	Blower Type (Digit 16)	Dimensions										
		HBP		HDP		HBP/HDP						
		A	C	A	C	B	E	F ①	G ①	H	J	M
75	All	84.41	81.49	113.63	110.82	34.85	19.52	78.66	53.72	1.53	32.00	6.23
100/125	All	84.41	81.49	113.63	110.82	37.36	19.52	78.66	53.72	1.53	34.50	7.49
150/175	All	84.41	81.49	113.63	110.82	41.61	23.49	78.66	53.72	1.53	38.75	7.63
200/225	All	84.41	81.49	113.63	110.82	43.71	23.49	78.66	53.72	1.53	40.85	8.69
250/300	E,F,G, or H	84.41	81.49	113.63	110.82	46.75	29.46	78.66	53.72	1.53	43.89	7.21
250/300	I, J, or K	120.00	117.34	149.22	146.66	46.75	29.46	114.23	84.29	1.28	43.89	7.21
350/400	E,F,G, or H	84.41	81.49	113.63	110.82	58.27	41.40	78.66	53.72	1.53	55.41	7.00
350/400	I, J, or K	120.00	117.34	149.22	146.66	58.27	41.40	114.23	82.29	1.28	55.41	7.00
500/600	G or H	117.53	114.94	146.77	144.12	46.75	29.46	78.66	53.72	1.53	43.89	7.21
500/600	I, J, K, or L	153.12	150.74	182.36	180.00	46.75	29.46	114.23	82.29	1.28	43.89	7.21
700/800	G or H	117.53	114.94	146.77	144.12	58.27	41.40	78.66	53.72	1.53	55.41	7.00
700/800	I, J, K, or L	153.12	150.74	182.36	180.00	58.27	41.40	114.23	82.29	1.28	55.41	7.00
840/960	I, J, K, or L	186.52	184.14	215.77	213.40	58.27	41.40	114.23	82.29	1.28	55.41	7.00

Table 45.2 - HCP & HPP Outdoor Unit Base Rail Dimensions (All dimensions in inches)

Model Size	Blower Type (Digit 16)	Dimensions										
		HCP		HPP		HCP/HPP						
		A	C	A	C	B	E	F	G	H	J	M
75	All	108.39	105.49	137.63	134.82	34.85	19.52	78.66	53.72	1.53	32.00	6.23
100/125	All	108.39	105.49	137.63	134.82	37.36	19.52	78.66	53.72	1.53	34.50	7.49
150/175	All	108.39	105.49	137.63	134.82	41.61	23.49	78.66	53.72	1.53	38.75	7.63
200/225	All	108.39	105.49	137.63	134.82	43.71	23.49	78.66	53.72	1.53	40.85	8.69
250/300	E,F,G, or H	108.39	105.49	137.63	134.82	46.75	29.46	78.66	53.72	1.53	43.89	7.21
250/300	I, J, or K	143.98	141.34	173.22	170.66	46.75	29.46	114.23	82.29	1.28	43.89	7.21
350/400	E,F,G, or H	108.39	105.49	137.63	134.82	58.27	41.40	78.66	53.72	1.53	55.41	7.00
350/400	I, J, or K	143.98	141.34	173.22	170.66	58.27	41.40	114.23	82.29	1.28	55.41	7.00

① Gas connection for 1st furnace. For Models 500-800 add 33.5" for second furnace gas connection. For Model 840-960 add 33.50" and 67.00" for second and third furnace gas connections.

DIMENSIONS - ROOF CURBS

Figure 46.1 - Roof Curb Dimensions

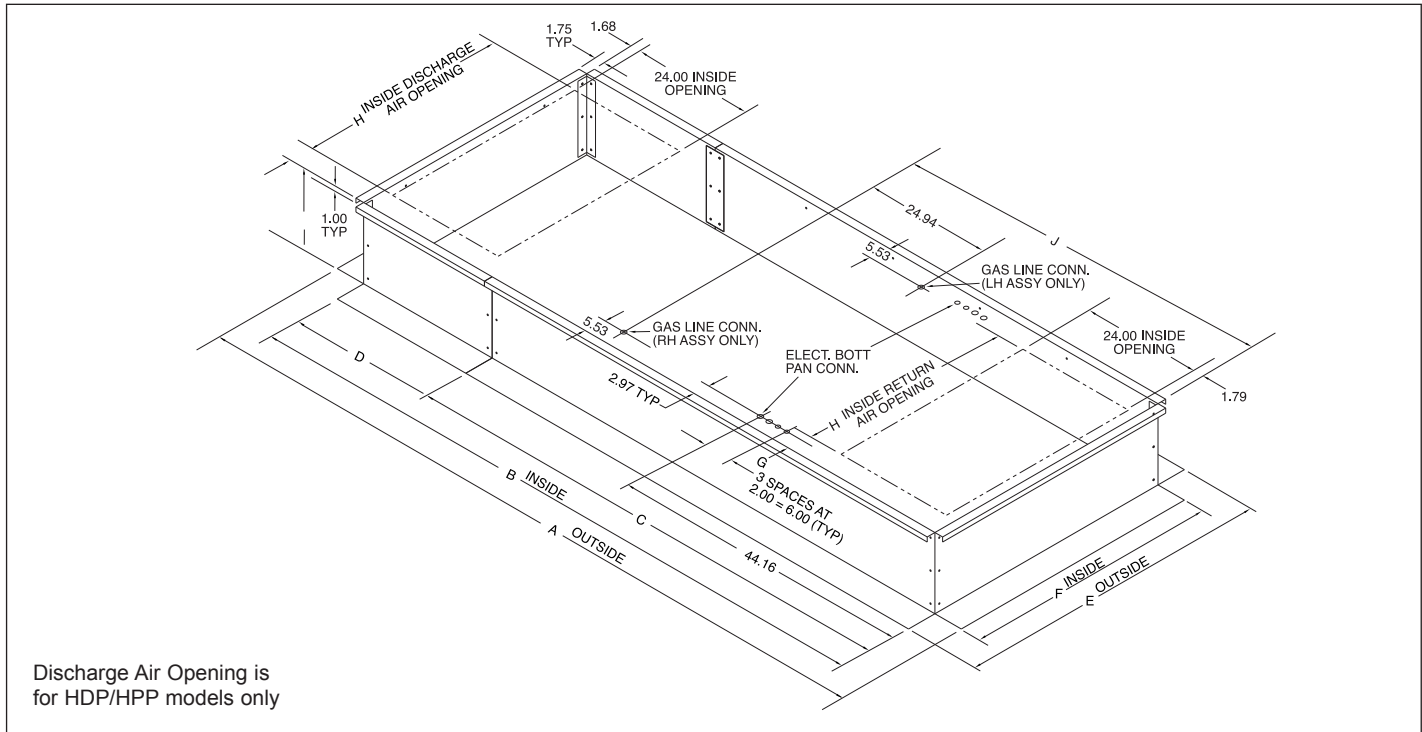

Table 46.1 - HBP & HDP Roof Curb Dimensions (All dimensions in inches)

Model Size	Blower Type (Digit 16)	Dimensions												
		HBP				HDP				HBP/HDP				
		A	B	C	D	A	B	C	D	E	F	G	H	J ①
75	All	88.77	76.77	-	-	117.98	105.98	-	-	39.33	27.33	3.97	19.52	74.84
100/125	All	88.77	76.77	-	-	117.98	105.98	-	-	41.84	29.84	5.22	19.52	74.84
150/175	All	88.77	76.77	-	-	117.98	105.98	-	-	46.18	34.18	5.41	23.49	74.84
200/225	All	88.77	76.77	-	-	117.98	105.98	-	-	48.22	36.22	6.43	23.49	74.84
250/300	E,F,G, or H	88.77	76.77	-	-	117.98	105.98	-	-	51.25	39.25	4.96	29.46	74.84
250/300	I, J, or K	124.61	112.61	-	-	153.83	141.63	105.98	35.85	51.25	39.25	4.96	29.46	110.41
350/400	E,F,G, or H	88.77	76.77	-	-	117.98	105.98	-	-	62.76	50.76	4.74	41.40	74.84
350/400	I, J, or K	124.61	112.61	-	-	153.83	141.63	105.98	35.85	62.76	50.76	4.74	41.40	110.41
500/600	G or H	121.89	109.89	-	-	151.10	139.10	105.98	33.12	51.25	39.25	4.96	29.46	74.84
500/600	I, J, K, or L	157.74	145.74	105.98	39.76	186.98	174.98	105.98	69.00	51.25	39.25	4.96	29.46	110.41
700/800	G or H	121.89	109.89	-	-	151.10	139.10	105.98	33.12	62.76	50.76	4.74	41.40	74.84
700/800	I, J, K, or L	157.74	145.74	105.98	39.76	186.98	174.98	105.98	69.00	62.76	50.76	4.74	41.40	110.41
840/960	I, J, K, or L	191.14	179.14	105.98	73.16	220.39	208.39	105.98	102.41	62.76	50.76	4.74	41.40	110.41

Table 46.2 - HCP & HPP Roof Curb Dimensions (All dimensions in inches)

Model Size	Blower Type (Digit 16)	Dimensions												
		HCP				HPP				HCP/HPP				
		A	B	C	D	A	B	C	D	E	F	G	H	J
75	All	112.74	100.74	-	-	141.98	129.98	100.74	29.24	39.33	27.33	3.97	19.52	74.84
100/125	All	112.74	100.74	-	-	141.98	129.98	100.74	29.24	41.84	29.84	5.22	19.52	74.84
150/175	All	112.74	100.74	-	-	141.98	129.98	100.74	29.24	46.18	34.18	5.41	23.49	74.84
200/225	All	112.74	100.74	-	-	141.98	129.98	100.74	29.24	48.22	36.22	6.43	23.49	74.84
250/300	E,F,G, or H	112.74	100.74	-	-	141.98	129.98	100.74	29.24	51.25	39.25	4.96	29.46	74.84
250/300	I, J, or K	148.59	136.59	105.98	30.61	177.83	165.83	105.98	59.85	51.25	39.25	4.96	29.46	110.41
350/400	E,F,G, or H	112.74	100.74	-	-	141.98	129.98	100.74	29.24	62.76	50.76	4.74	41.40	74.84
350/400	I, J, or K	148.59	136.59	105.98	30.61	177.83	165.83	105.98	59.85	62.76	50.76	4.74	41.40	110.41

① Gas connection for 1st furnace. For Models 500-800 add 33.5" for second furnace gas connection. For Model 840-960 add 33.50" and 67.00" for second and third furnace gas connections.

DIMENSIONS - COOLING COILS

Figure 47.1 - DX Coil Drawing (All dimensions in inches)

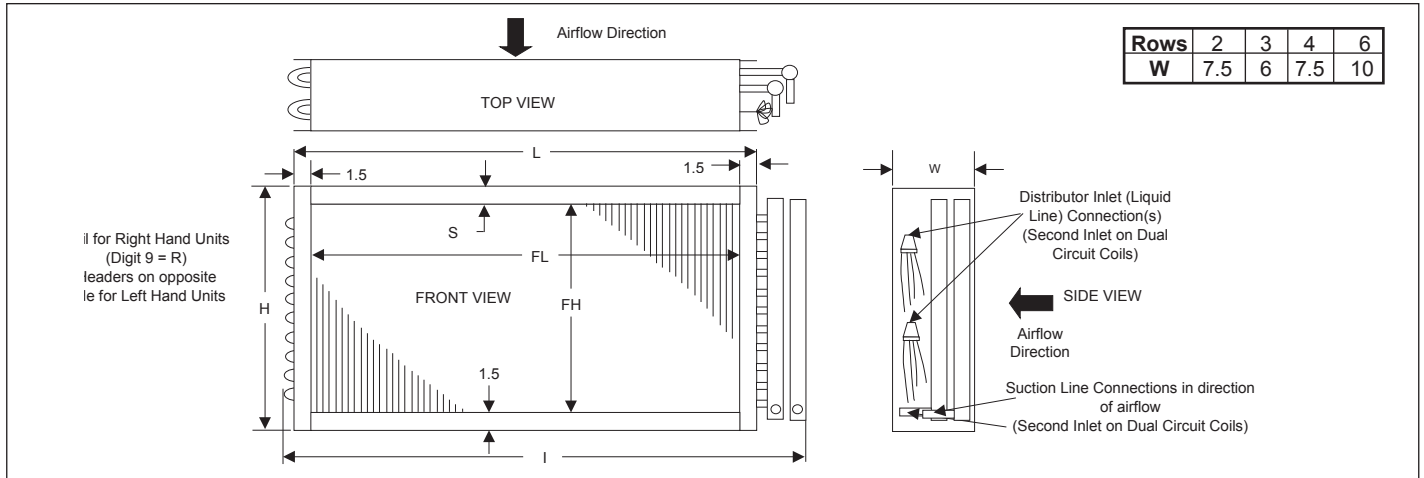

Table 47.1 - DX Coil Dimensions

Model Size	Cooling MBH	FH	H	S	DX - Single Circuit ①			DX - Dual Circuit ②		
					FL	I	L	FL	I	L
75	All	27.5	30.5	1.5	18	25	21	16.25	26.5	19.25
100/125	All	27.5	30.5	1.5	21	28	24	19.5	29.75	22.5
150/175	All	27.5	30.5	1.5	24	31	27	23	33.25	28.5
200/225	Below 185 MBH	32.5	34.5	0.5	27	34	30	25.5	35.75	28.5
	185 MBH & Up	32.5	34.5	0.5	27	34.5	30			
250/300	Below 185 MBH	32.5	34.5	0.5	30	37	33	28.5	38.75	31.5
	185 MBH & Up	32.5	34.5	0.5	30	37.5	33			
350/400	Below 185 MBH	32.5	34.5	0.5	42	49	45	40.25	50.5	43.25
	185 MBH & Up	32.5	34.5	0.5	42	49.5	45			

- ① Single Circuit DX coils have 1 each Suction Line and Liquid Lines. Refer to AccuSpec for line size diameters.
- ② Dual Circuit DX coils have 2 each Suction Line and Liquid Lines. Refer to AccuSpec for line size diameters.

Figure 47.2 - Chilled Water Coil Drawing (All dimensions in inches)

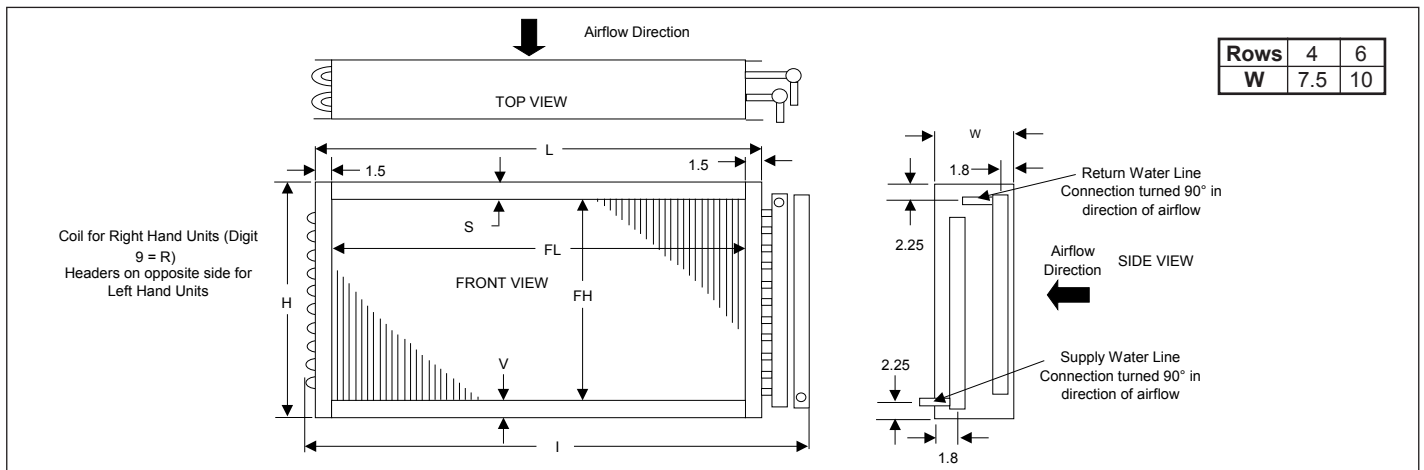

Table 47.2 - Chilled Water Coil Dimensions

Model Size	FH	H	S	V	FL	I	L	Supply Line	Return Line
75	27	30	1.5	1.5	16.25	25.50	19.25	1.50 MPT	1.50 MPT
100/125	27	30	1.5	1.5	19.50	28.75	22.50	1.50 MPT	1.50 MPT
150/175	27	30	1.5	1.5	23.00	32.25	26.00	1.50 MPT	1.50 MPT
200/225	33	34.5	0.5	1	25.50	34.75	28.50	1.50 MPT	1.50 MPT
250/300	33	34.5	0.5	1	28.50	37.75	31.50	1.50 MPT	1.50 MPT
350/400	33	34.5	0.5	1	40.25	49.50	43.25	1.50 MPT	1.50 MPT

DIMENSIONS - RAINHOOD, REMOTE PANEL & EVAPORATIVE COOLER

Figure 48.1 - Rainhood and Birdscreen Dimensions

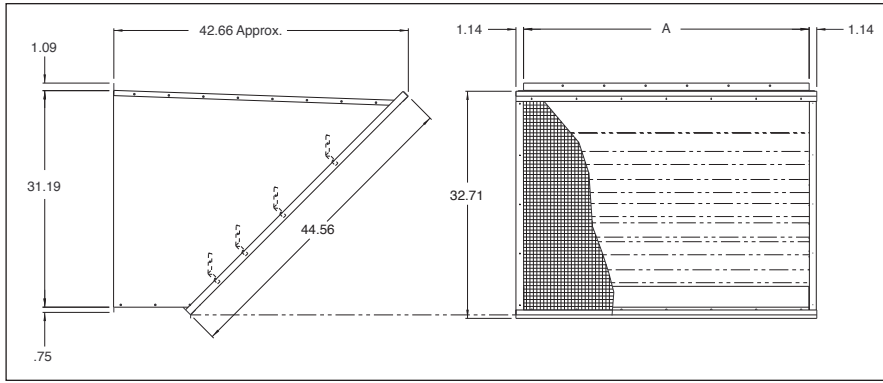

Table 48.1 - Rainhood and Birdscreen Dimensions (inches)

Rainhood & Birdscreen	
Model Size	A
75	29.43
100/125	31.94
150/175	38.24
200/225	38.24
250/300	41.34
350/400	52.85
500/600	41.34
700/800	52.85
840/960	52.85

Figure 48.2 - Evaporative Cooling Module

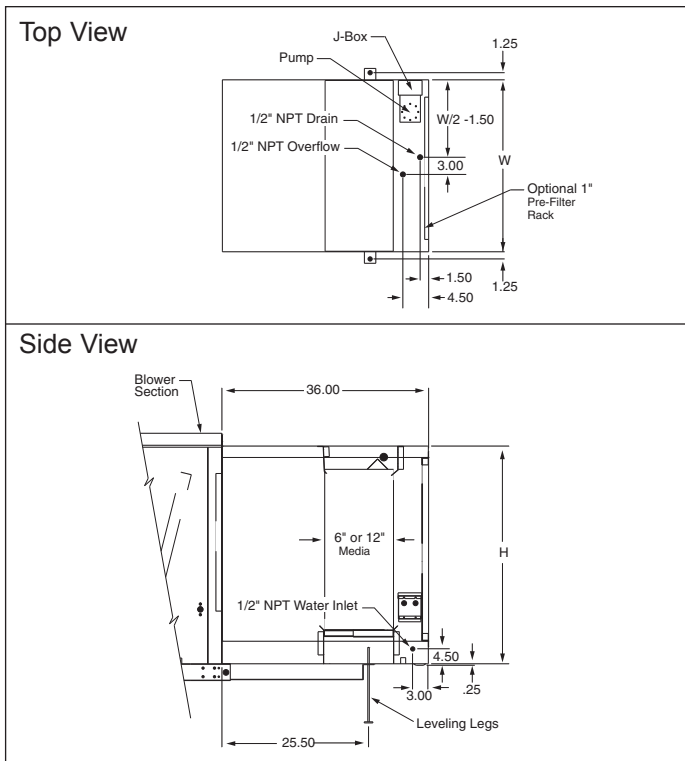

Figure 48.3 - Remote Panel Dimensions

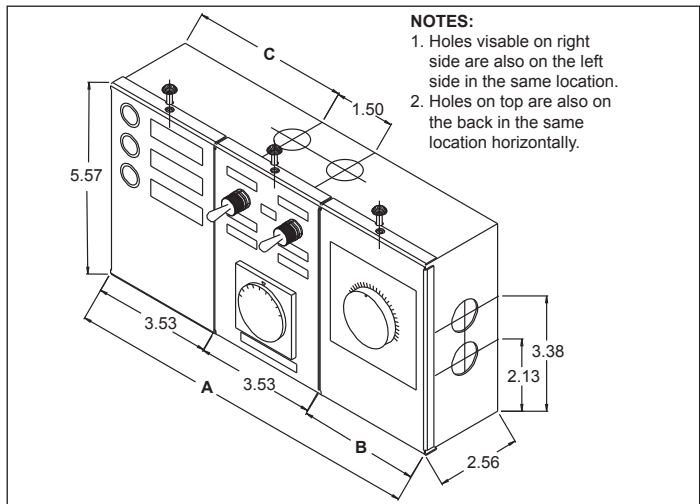

Table 48.3 - Remote Panel Dimensions (inches)

Remote Panel Type	A	B	C
Light and Switch Panels Only	7.06	-	2.81
Light and Switch Panels with Single Stage Thermostat or Electronic Set Point Adjustor	10.60	3.53	4.58
Light and Switch Panels with Two Stage Thermostat	13.09	6.03	5.82

Table 48.2 - Evap Cooler Dimension, Performance, and Weight Data

Model Size	Blower Type (digit 16)	H (in.)	W (in.)	Maximum Cooling CFM	Media Face Area (ft ²)	Face Velocity @ Max CFM (ft/min)	12" Media (Digit 23 = B or D)	
							Dry Weight (lbs)	Op. Weight (lbs)
75	All	34	30	2778	4.0	695	154	285
100/125	All	34	30	4000	5.0	800	159	295
150/175	All	34	36	5200	6.5	800	169	336
200/225	All	38	36	6000	7.5	800	174	341
250/300	E, F, G, or H	38	39	6500	8.1	800	182	363
250/300	I, J, or k	56	39	10400	13.0	800	214	404
350/400	E, F, G, or H	38	51	8500	10.6	800	228	473
350/400	I, J, or k	47	51	11050	13.8	800	244	496
500/600	G or H	38	39	6500	8.1	800	182	363
500/600	I, J, k or L	56	39	10400	13.0	800	214	404
700/800	G or H	38	51	8500	10.6	800	228	473
700/800	I, J, k or L	47	51	11050	13.8	800	244	496
840/960	I, J, k or L	47	51	11050	13.8	800	244	496

WEIGHTS

Table 49.1 - Unit Operating Weights ①

Model Size	Blower Type (Digit 16)	Base Unit				Motor	Filters	Dampers		Rain-hood	Double Wall (all sections)				Evap Cooler
		HBP	HDP	HCP	HPP			Fresh Air Only	Fresh & Return Air		HBP	HDP	HCP	HPP	
75	All	439	540	546	647	See Motor Data	6	26	46	65	38	73	72	107	See Evaporative Cooler Data
100/125	All	474	578	584	688		6	26	46	67	38	73	72	107	
150/175	All	511	621	626	736		6	29	52	70	43	78	77	112	
200/225	All	588	707	714	833		6	29	52	72	46	86	85	125	
250/300	E,F,G, or H	626	747	756	877		8	33	60	83	46	88	87	129	
250/300	I, J, or k	875	996	1005	1126		15	33	60	83	93	135	134	176	
350/400	E,F,G, or H	738	876	887	1025		12	38	70	90	53	102	101	150	
350/400	I, J, or k	1019	1057	1168	1306		17	38	70	90	96	145	144	193	
500/600	G or H	959	1080	n/a	n/a		8	33	60	83	46	88	n/a	n/a	
500/600	I, J, k, or L	1208	1329	n/a	n/a		15	33	60	83	93	135	n/a	n/a	
700/800	G or H	1153	1291	n/a	n/a		12	38	70	90	53	102	n/a	n/a	
700/800	I, J, k, or L	1352	1490	n/a	n/a		17	38	70	90	96	145	n/a	n/a	
840/960	I, J, k, or L	1767	1905	n/a	n/a		17	38	70	90	96	145	n/a	n/a	

Table 49.2 - Motor Operating Weights ①

Digit 14 - Supply Voltage	Digit 18 - Motor Type	Digit 17 - Motor Size												
		A or L	B or M	C or N	D or P	E or Q	F or R	G or S	H or T	I or W	J or X	K or Y	V or Z	
		1/3	1/2	3/4	1	1-1/2	2	3	5	7-1/2	10	15	20	
A - 115/60/1ph	1 - ODP	25	23	25	32	40	49	81	-	-	-	-	-	
	5 - TE	25	28	30	37	45	49	83	-	-	-	-	-	
B - 208/60/1ph	1 - ODP	-	23	25	32	40	49	81	87	-	-	-	-	
	5 - TE	-	28	30	37	45	49	83	86	-	-	-	-	
C - 230/60/1ph	1 - ODP	25	23	25	32	40	49	81	87	-	-	-	-	
	5 - TE	25	28	30	37	45	49	83	86	-	-	-	-	
D - 208/60/3ph	1 - ODP	17	18	21	-	-	-	-	-	-	-	-	-	
	2 - ODP HE	-	-	-	83	94	99	83	94	141	126	220	250	
	5 - TE	15	23	26	-	-	-	-	-	-	-	-	-	
	6 - TE HE	-	-	-	68	66	66	92	99	158	200	259	368	
E - 230/60/3ph	1 - ODP	17	18	21	-	-	-	-	-	-	-	-	-	
	2 - ODP HE	-	-	-	40	46	54	87	94	130	126	217	250	
	5 - TE	15	23	30	-	-	-	-	-	-	-	-	-	
	6 - TE HE	-	-	-	53	66	67	92	117	194	213	322	368	
F - 460/60/3ph	1 - ODP	17	18	21	-	-	-	-	-	-	-	-	-	
	2 - ODP HE	-	-	-	40	46	54	87	94	130	126	217	250	
	5 - TE	15	23	30	-	-	-	-	-	-	-	-	-	
	6 - TE HE	-	-	-	53	66	66	92	117	194	213	322	368	
G - 575/60/3ph	1 - ODP	-	25	28	-	-	-	-	-	-	-	-	-	
	2 - ODP HE	-	-	-	35	40	45	76	89	90	220	310	360	
	5 - TE	-	24	33	-	-	-	-	-	-	-	-	-	
	6 - TE HE	-	-	-	68	40	67	100	125	192	200	326	368	

① All weights in pounds and are approximate.

MAINTENANCE

⚠ WARNING

When servicing or repairing this equipment, use only factory-approved service replacement parts. A complete replacement parts list may be obtained by contacting Modine Manufacturing Company. Refer to the rating plate on the appliance for complete appliance model number, serial number, and company address. Any substitution of parts or controls not approved by the factory will be at the owner's risk.

⚠ CAUTION

Do not attempt to reuse any mechanical or electrical controllers which have been wet. Replace defective controller.

IMPORTANT

To check most of the Possible Remedies in the troubleshooting guide listed in Table 52.1, refer to the applicable sections of the manual.

All heating equipment should be serviced before each heating season to assure proper operations. The following items may be required to have more frequent service schedule based on the environment in which the unit is installed, and the frequency of the equipment operation.

Blower Assembly

The blower assembly includes the bearings, drive sheaves and belts. Blower bearings should be checked and lubricated based on the blower manufacturer's recommendations. Bearings should also be checked for any unusual wear and replaced if needed. Drive sheaves should be checked at the same time the bearings are inspected. Check to make sure the sheaves are in alignment and are securely fastened to the blower and motor shafts. Belt tension should be rechecked shortly after the unit has been installed to check for belt stretching. After the initial start-up, monthly checks are recommended.

Filters

If the unit is supplied with a dirty filter switch and light, clean or replace the filters any time the dirty filter light comes on. Units which do not have a dirty filter warning light should have the filters checked monthly. Clean or replace if necessary. In dirty atmospheres, filter maintenance may be required more often.

Figure 50.1 - Filter Replacement Arrangement for Blower Size (Digit 16) A, B, C, D, E, F, G and H

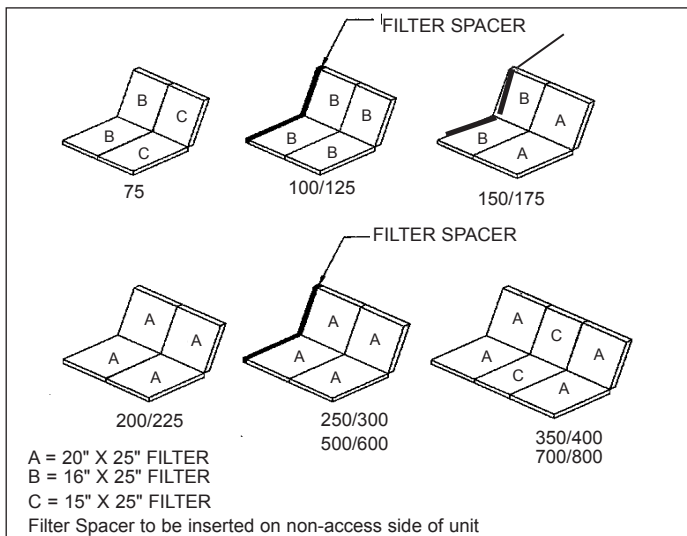
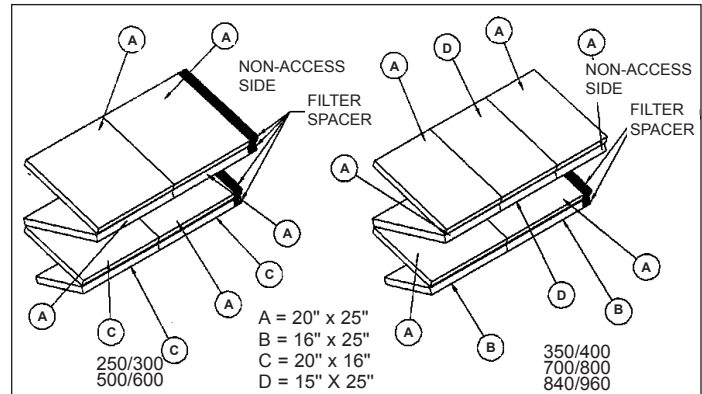

Figure 50.2 - Filter Replacement Arrangement for Blower Size (Digit 16) I, J, K, and L



Cooling Coil Drain Pan and Drain System

The drain pan, trap, and drain pipe must be cleaned regularly to avoid blockage that can reduce or stop water flow as follows:

1. At the beginning of the cooling season, inspect and clean the entire cooling coil cabinet and condensate drain pan to remove contaminants.
2. Inspect and clean the condensate drain trap and piping. The use of a cleanout opening at the top of the trap can help facilitate this maintenance.
3. Fill the trap with water to ensure proper operation and replace the cap on the cleanout opening to close the system.
4. During the end of cooling season shutdown of the system, disconnect and remove all water from the trap and drain to prevent freeze damage. If local building codes permit, the trap may be filled with an antifreeze solution.
5. If the unit is used year round, regularly inspect and clean the cooling coil cabinet, condensate drain pan, and trap/drain system to ensure proper function.
6. Depending on climate, freeze protection of the trap may be required during non-cooling days.

Cooling Coil Maintenance

1. Periodically, inspect the coil for signs of corrosion and leaks. Repair and replacement of the coil and the connecting piping, valves, etc., must be performed as needed by a qualified technician.
2. Should the coil surface need cleaning, caution should be exercised in selecting the cleaning solution as well as the cleaning equipment. Improper selection can result in damage to the coil and/or health hazards. Cleaning solutions must not be corrosive or cause damage to copper tube/aluminum fin coils. Clean the coil from the leaving air-side so that foreign material will be washed out of the coil rather than pushed further in. Be sure to carefully read and follow the cleaning fluid manufacturer's recommendations before using any cleaning fluid.
3. For DX coils, replace the filter dryer(s) as needed.
4. For chilled fluid coils:
 - a. Maintain the circulated fluid free of sediment, corrosive products and biological contaminants.
 - b. Freeze Protection - During the winter, chilled water coils need to be protected against freezing. Two common methods are 1) blowing out the coils with air, or 2) flushing coils with inhibited glycol designed for corrosion protection in HVAC applications. Select an inhibited glycol solution that will protect the coil from the lowest possible temperatures that can occur at that locality.

Electrical Wiring

The electrical wiring should be checked annually for loose connections or deteriorated insulation.

Duct Furnace

When providing annual maintenance for the duct furnace, keep the unit free from dust, dirt, grease and foreign matter. Pay particular attention to:

1. The power exhauster discharge opening and the combustion air inlet louvers.
2. The burner ports and pilot burner orifices (avoid the use of hard, sharp instruments capable of damaging surfaces for cleaning these ports). To check the burner port and pilot burner orifice, see Burner and Pilot Assembly Removal.
3. The air shutters and main burner orifices (avoid the use of hard, sharp instruments capable of damaging surfaces for cleaning these orifices). To check the air shutters and main burner orifices, see for Manifold Assembly Removal.

The heat exchanger should be checked annually for cracks and discoloration of the tubes. If a crack is detected, the heat exchanger should be replaced before the unit is put back into service. If the tubes are dark gray, airflow across the heat exchanger should be checked to insure that a blockage has not occurred or the blower is operating properly.

Gas Piping & Controls

The gas valves and piping should be checked annually for general cleanliness and tightness.

The gas controls should be checked to insure that the unit is operating properly.

Manifold Assembly Removal

To remove the manifold (Refer to Figure 51.1):

1. Shut off gas and electric supply.
2. Remove the side access panel.
3. Disconnect gas manifold at ground union joint.
4. Remove the two screws holding the manifold to the heat exchanger support.
5. Slide the manifold through the manifold bracket.
6. Clean the orifices and adjust the air shutters as necessary.
7. Follow steps 3-6 in reverse to install the manifold assembly.
8. Turn on the electric and gas supply.
9. Check the ground union joint for leaks with a soap solution. Tighten if necessary.
10. Install the side access panel.

Figure 51.1 - Manifold Assembly Removal

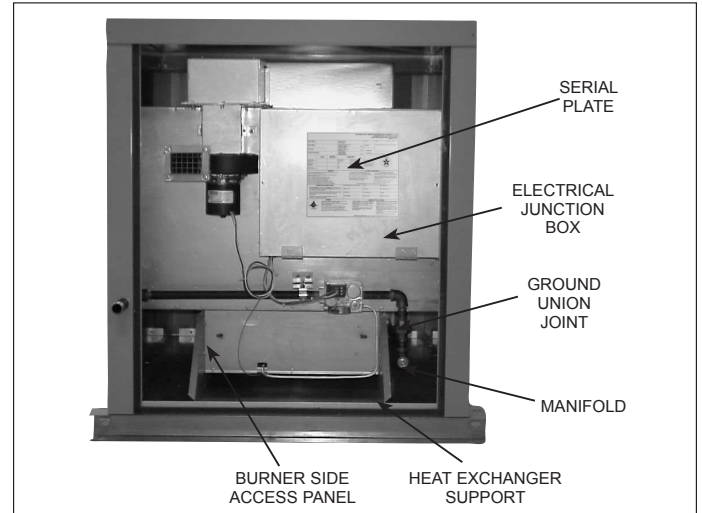

Burner and Pilot Assembly Removal

To remove the burner (Refer to Figure 51.2):

1. Shut off gas and electric supply.
2. Disconnect the pilot supply line from the gas valve.
3. Disconnect the ignition cable from the ignition controller (located in the electrical junction box). Feed the cable through the bushing in the bottom of the electrical junction box.
4. Remove the screws holding the burner side access panel. Attached to the panel are the burner retaining pins that align the burner.
5. Slide the burner assembly out. The pilot is attached to the burner assembly.
6. Examine the burner and pilot assembly for cleanliness and/or obstructions as necessary (see Duct Furnace for cleaning instructions).
7. Replace the burner assembly in reverse order. In replacing the burner, be certain that the rear burner slots are located properly on the burner retaining pins. Do not force the burner side access panel, it will not fit if the burner is not properly aligned.
8. Reconnect the ignition cable and pilot gas supply line.
9. Turn on the electric and gas supply.

Figure 51.2 - Burner and Pilot Assembly Removal

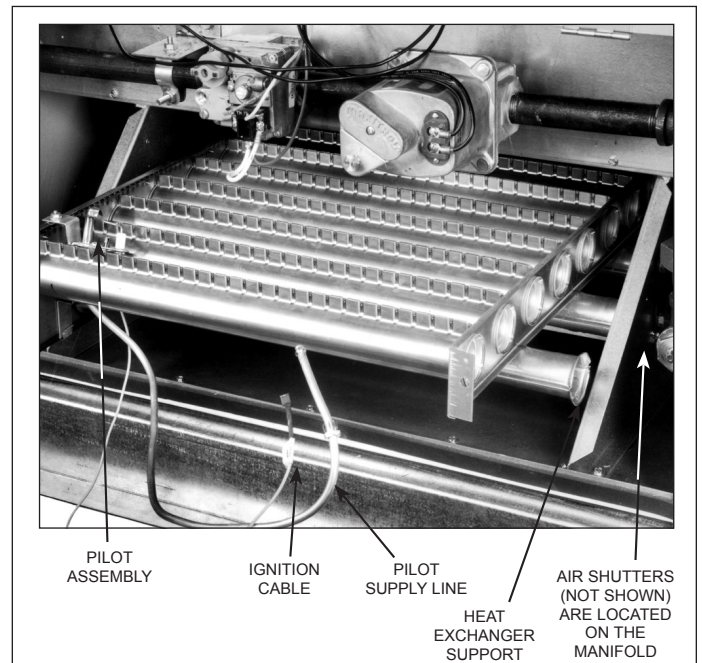

SERVICE & TROUBLESHOOTING

WARNING

When servicing or repairing this equipment, use only factory-approved service replacement parts. A complete replacement parts list may be obtained by contacting Modine Manufacturing Company. Refer to the rating plate on the unit for complete unit model number, serial number, and company address. Any substitution of parts or controls not approved by the factory will be at the owner's risk.

CAUTION

Do not reuse any mechanical or electrical component which has been wet. Such component must be replaced.

IMPORTANT

To check most of the Possible Remedies in the troubleshooting guide listed in Table 52.1, refer to the applicable sections of the manual.

Table 52.1 - Troubleshooting

Trouble	Possible Cause	Possible Remedy
Pilot does not light	<ol style="list-style-type: none"> 1. Main gas is off. 2. Power supply is off. 3. Air in gas line. 4. Dirt in pilot orifice. 5. Gas pressure out of proper range. 6. Pilot valve does not open. <ol style="list-style-type: none"> a. Defective ignition controller. b. Defective gas valve. 7. No Spark at ignitor. <ol style="list-style-type: none"> a. Loose wire connections. b. Pilot sensor is grounded. c. Defective ignition controller. 8. Safety device has cut power. 	<ol style="list-style-type: none"> 1. Open manual gas valve. 2. Turn on main power. 3. Purge gas line. 4. Check for plugged pilot orifice and clean with compressed air if necessary. 5. Adjust to a maximum of 14" W.C. Minimum for Natural Gas - 6" W.C. Minimum for Propane Gas - 11" W.C. 6. Check wiring for 24 volts to valve. <ol style="list-style-type: none"> a. Replace ignition controller. b. Replace gas valve. 7. <ol style="list-style-type: none"> a. Check all ignition controller wiring. b. Replace sensor if cracked or worn c. Replace ignition controller. 8. Check all safety devices (High limit, air flow proving switch, power exhauster centrifugal switch - HFP Models Only, gas pressure switches, etc.) Determine and correct problem. Reset if necessary.
Main burners do not light (Pilot is lit)	<ol style="list-style-type: none"> 1. Defective valve. 2. Loose wiring. 3. Defective pilot sensor 4. Defective ignition controller. 5. Improper thermostat wiring. 	<ol style="list-style-type: none"> 1. Replace valve. 2. Check wiring to gas valve. 3. Replace pilot sensor. 4. Replace ignition controller. 5. Verify wiring compared to wiring diagram.
Lifting Flames (See Figure 53.1)	<ol style="list-style-type: none"> 1. Too much primary air. 2. Main pressure set too high. 3. Orifice too large. 	<ol style="list-style-type: none"> 1. Reduce primary air. 2. Adjust to a maximum of 14" W.C. 3. Check orifice size with those listed on the serial plate.
Yellow Tipping (With propane gas, some yellow tipping is always present.)	<ol style="list-style-type: none"> 1. Insufficient primary air. 2. Dirty orifice. 3. Misaligned orifice. 	<ol style="list-style-type: none"> 1. Increase primary air. 2. Check orifices and clean with compressed air if necessary. 3. Check manifold, replace if necessary.
Flashback	<ol style="list-style-type: none"> 1. Too much primary air. 2. Main pressure set too high. 3. Orifice too large. 	<ol style="list-style-type: none"> 1. Reduce primary air. 2. Adjust to a maximum of 14" W.C. 3. Check orifice size with those listed on the serial plate.
Floating Flames (See Figure 53.2)	<ol style="list-style-type: none"> 1. Insufficient primary air. 2. Main pressure set too high. 3. Orifice too large. 4. Blocked vent cap. 	<ol style="list-style-type: none"> 1. Increase primary air. 2. Adjust to a maximum of 14" W.C. 3. Check orifice size with those listed on the serial plate. 4. Clean louvers in vent cap.

SERVICE & TROUBLESHOOTING

Trouble	Possible Cause	Possible Remedy
Flame Rollout (See Figure 53.3)	<ol style="list-style-type: none"> Main pressure set too high. Orifice too large. Blocked vent cap. 	<ol style="list-style-type: none"> Adjust to a maximum of 14" W.C. Check orifice size with those listed on the serial plate. Clean louvers in vent cap.
Not Enough Heat	<ol style="list-style-type: none"> Unit cycling on high limit. ① <ol style="list-style-type: none"> Obstructions/leaks in duct system. Main pressure set too high. Blower motor not energized. Loose belt Blower speed too low. Blocked/damaged venting system. Air distribution baffle removed (high temperature rise units only). Defective high limit switch. Main pressure set too low. Too much outside air. Thermostat malfunction. Gas controls wired incorrectly. Unit undersized. 	<ol style="list-style-type: none"> <ol style="list-style-type: none"> Clean/correct duct system. Adjust to a maximum of 14" W.C. Check/correct to insure blower motor operates within 45 seconds of when gas controls are energized. Adjust belt tension. Check/correct blower drive settings for proper rpm. Check/correct venting system. Replace air distribution baffle. Replace high limit switch. Adjust main gas pressure. Minimum for Natural Gas — 6" W.C. Minimum for Propane Gas — 11" W.C. Adjust outside air damper to decrease outside air percentage (if possible). Check/replace thermostat. Check unit wiring against the wiring diagram. Check design conditions. If unit is undersized, an additional unit(s) or other heat source must be added.
Too Much Heat	<ol style="list-style-type: none"> Thermostat malfunction. Gas controls do not shut-off. <ol style="list-style-type: none"> Gas controls wired incorrectly. Short circuit. Main gas pressure set too high. Defective gas valve. 	<ol style="list-style-type: none"> Check/replace thermostat. <ol style="list-style-type: none"> Check unit wiring against the wiring diagram. Check for loose or worn wires. Adjust to a maximum of 14" W.C. Replace gas valve.
Power Exhauster Motor will not start	<ol style="list-style-type: none"> Power supply is off. No 24V power to thermostat. Thermostat malfunction. Defective power exhauster relay. Defective power exhauster motor. 	<ol style="list-style-type: none"> Turn on main power. Check control transformer. Check/replace thermostat. Replace power exhauster relay. Replace power exhauster motor.

① Automatic Reset High Limit

The duct furnace comes standard with an automatic reset high limit switch that will shut-off the gas should the discharge air temperature become excessive. See Figure 19.1, indicator ④⑨ for the location of either the standard automatic or optional manual reset high limit switch. The switch should operate only when something is seriously wrong with the unit operation. Anytime the switch operates, correct the difficulty immediately or serious damage may result. If the switch cuts off the gas supply during normal operation, refer to the "Not Enough Heat" section of Service & Troubleshooting.

Figure 53.1
Lifting Flame Condition

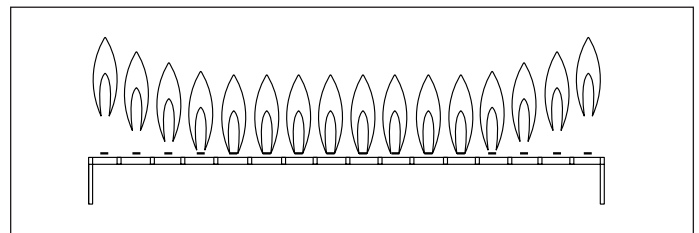

Figure 53.2
Floating Flame Condition

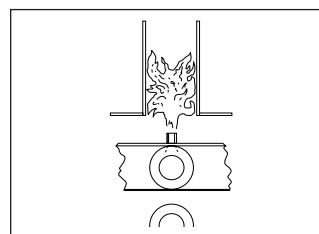
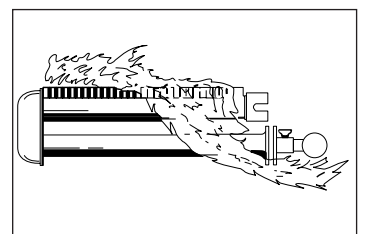

Figure 53.3
Flame Rollout Appearance



MODEL DESIGNATIONS

Model Identification

Modine weatherproof duct furnace/make-up air units contain an ETL/ETL Canada certified weatherproof duct furnace. This duct furnace is combined with either a blower section, or a blower and/or cooling and/or downturn sections to make a complete make-up air or heating/ventilating/cooling unit that is ETL/ETL Canada certified. For this reason, two identification plates are used on these models. The **Serial Plate** is used to identify the duct furnace and its components. The **Model Identification Plate** is used to identify the complete model, including blower, cooling, and/or downturn sections.

Ordering

When servicing, repairing or replacing parts on these units, locate the model identification plate of the unit and always give the complete Model Number and Serial Number from the model identification plate. The model identification plate is located on the door of the electrical control box (See Figure 54.1). The part number for some common replacement parts are listed on the serial plate (See Figure 54.2) and the model identification plate (See Figure 55.1). For a complete description of the model number, see Model Identification.

Figure 54.1 - Serial Plate and Model ID Plate Locations

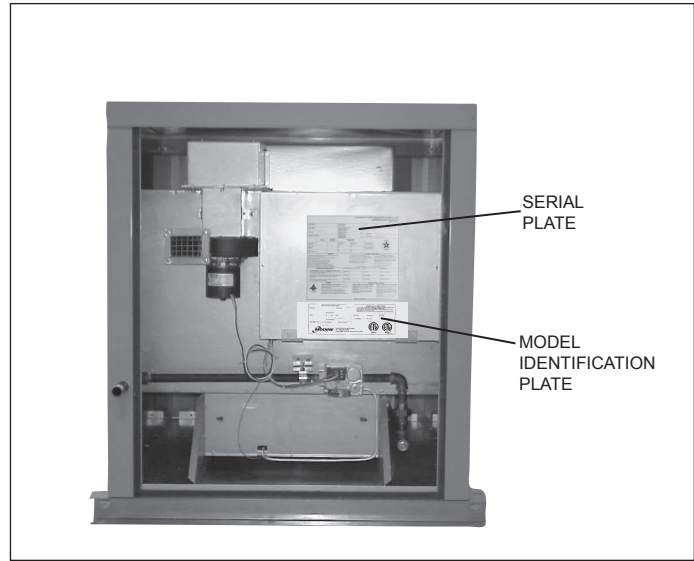

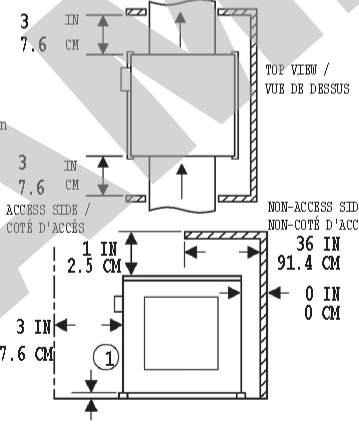
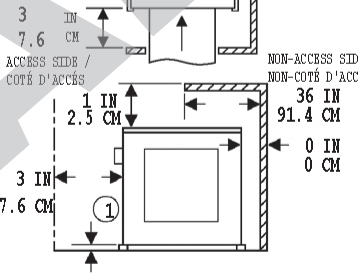

Figure 54.2 - Serial Plate

Modine Manufacturing Company 1500 DeKoven Avenue Racine, WI 53403-2552 Phone: 800-828-4328		OUTDOOR GAS-FIRED DUCT FURNACE FOR INDUSTRIAL / COMMERCIAL USE CHAUDIERE À GAZ À CONDUIT POUR EXTERIEUR / POUR USAGE INDUSTRIEL/COMMERCIAL		Made in U.S.A.		APPROVALS  Intertek 9900100 DESIGN COMPLIES WITH DUCT FURNACE STANDARD: ANSI Z83.8-2013 CSA 2.6-2013 APPROVED FOR USE IN MASSACHUSETTS APPROVED FOR USE IN CA BY THE CRC	
MODEL NUMBER NUMERO DE MODELE HFP 75SMRHP40A1		MIN. INPUT DEBIT CALORIFIQUE MIN. 30000 BTU/HR 8784 W		VOLTS 115		PHASE 1 HERTZ 60 AMPS 1.75	
SERIAL NUMBER NUMERO DE SERIE 0917093615-0036		MIN. INLET PRESS. FOR PURPOSE OF INPUT ADJUSTMENT / PRESSION D'ALIMENTATION EN GAZ MIN. ADMISE 11 IN W.C. 2.74 kPa		MANIFOLD PRESSURE PRESSION A LA TUBULURE D'ALIMENTATION 10 IN W.C. 2.49 kPa			
TYPE OF GAS TYPE OF GAZ Propane		MAXIMUM EXTERNAL STATIC PRESSURE PRESSION STATIQUE EXTERIEUR MAXIMUM 3 IN W.C. 0.75 kPa		TEMPERATURE RISE RANGE ELEVATION DE TEMPERATURE 20-100 °F -7- 38 °C			
(IN CANADA) 0 TO 2000 FT. 0 FT 610 M		2000 TO 4500 FT. 610 FT 1370 M		AIR THROUGHPUT DEBIT D'AIR			
INPUT DEBIT CALORIFIQUE 75000 BTU/HR 21960 W		MIN. CFM CMH MIN 563		GENERAL 1. FOR OUTDOOR INSTALLATIONS ONLY. 2. MINIMUM AMBIENT TEMPERATURE -40° F. 3. FOR INSTALLATION DOWNSTREAM OF REFRIGERATION SYSTEMS. 4. INSTALL ON THE POSITIVE PRESSURE SIDE OF AIR CIRCULATING BLOWER. 5. FOR UNITS WITH MANUAL RESET HIGH LIMIT SWITCH, RESET BUTTON IS LOCATED IN ELECTRICAL JUNCTION BOX. 6. (IN USA) FOR INSTALLATIONS ABOVE 2000 FEET DEBATE 4 PERCENT FOR EACH 1000 FEET OF ELEVATION ABOVE SEA LEVEL. LIGHTING INSTRUCTIONS 1. OPEN ALL GAS VALVES. TURN ON POWER. 2. SET THERMOSTAT TO DESIRED SETTING. SHUT DOWN INSTRUCTIONS: 1. TURN OFF POWER & CLOSE ALL GAS VALVES. REFER TO INSTALLATION & SERVICE MANUAL FOR MORE INSTRUCTIONS * FOR UNITS WITH 2-STAGE, MECHANICAL MODULATION, OR ELECTRONIC MODULATING GAS CONTROLS, A FACTORY DISCHARGE AIR CONTROLLER AND NO ROOM THERMOSTAT INCLUDED.			
OUTPUT RENDEMENT 60750 BTU/HR 17568 W		MAX. CFM CMH MAX 2813					
ORIFICE SIZE DIM. DE L'INJECTEUR 37		MIN VARIABLE SPEED CFM MIN VARIABLE SPEED CMH 422					
RECOMMENDED SERVICE CLEARANCE / DÉGAGEMENT DE SERVICE RECOMMANDÉ				COMBUSTIBLE MATERIALS AND SERVICE CLEARANCES / MATÉRIAUX COMBUSTIBLES ET DÉGAGEMENTS D'ENTRETIEN AIR FLOW / AIR COURANT			
ACCESS SIDE 18 IN CÔTÉ D'ACCÈS 45.7 CM		NON-ACCESS SIDE 6 IN CÔTÉ NON-ACCÈS 15.2 CM		COMMON REPLACEMENT PARTS For parts ordering, contact the parts wholesaler or the manufacturer's representative serving your area. When inquiring about parts, always provide model number, serial number, description, and part number. When ordering parts, provide part number listed. For service, contact your local qualified installation and service contractor or appropriate utility company.			
				1. MINIMUM CLEARANCE TO COMBUSTIBLES IS 0.0" FROM BOTTOM OF UNIT MOUNTING RAIL OR 3" FROM BOTTOM OF SHEET METAL CASING. 1. LE DÉGAGEMENT MINIMUM DU COMBUSTIBLE EST 0.0 CM DU BAS DE LA BARRE QUI SUPPORTE L'ÉLÉMENT OU 7.6 CM DU BAS DE L'ENVELOPPE DE TÔLE.			

MODEL DESIGNATIONS

Figure 55.1 - Model Identification Plate



MODEL IDENTIFICATION PLATE				COMMON REPLACEMENT PARTS			
Model Number HBG 75AFRHN10A1AA1AAA1A		Serial Number		For parts ordering, contact the parts wholesaler or the manufacturer's representative serving your area. A complete listing of both can be found in your Installation and Service Manual. When inquiring about parts, always provide model number, serial number, description and part number. When ordering parts, provide part number listed. For service, contact your local qualified installation and service contractor or appropriate utility company.			
MOTOR DATA							
Voltage 115/208-230	Hertz 60	Phase 1	Amps 6.6/3.0-3.3	Blower Motor 9F20218	Blower Sheave 5H63081-20	Blower Belt 5H76183-31	
SYSTEM DATA							
Supply Voltage 115	Hertz 60	Phase 1	Max System Amps 8.47	Eye Size (Time Delay) 10.00	Blower Relay 5H71780	Motor Sheave 5H58084-3	
 Modine Manufacturing Company 1500 DeKoven Ave., Racine, WI 53403 Phone: 800.828.4328				Design conforms to: UL Std 1995		 	
				Certified to: CAN/CSA C22.2 No. 236			

Figure 55.2 - Duct Furnace Serial Number Designations ①

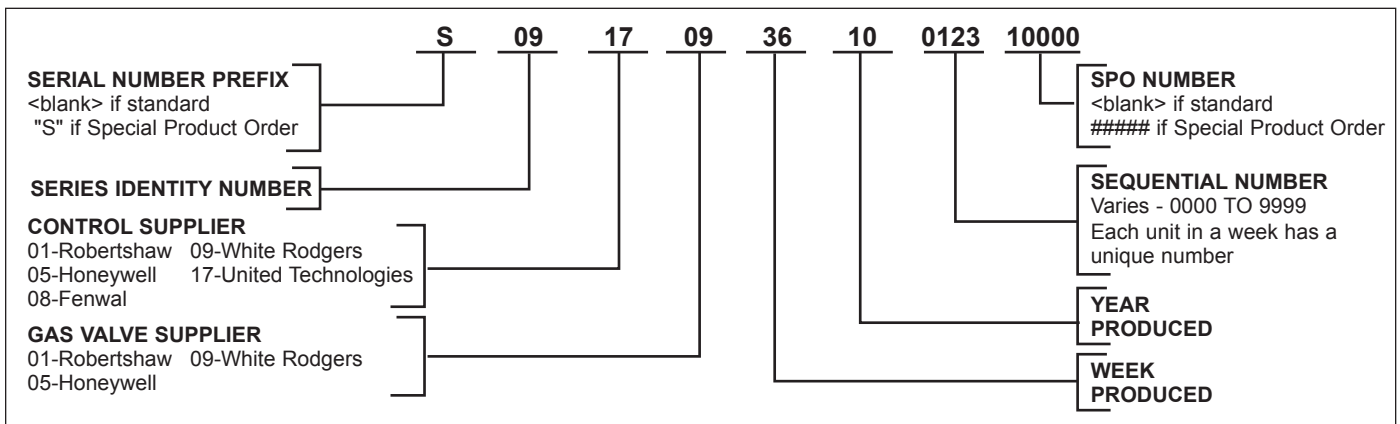
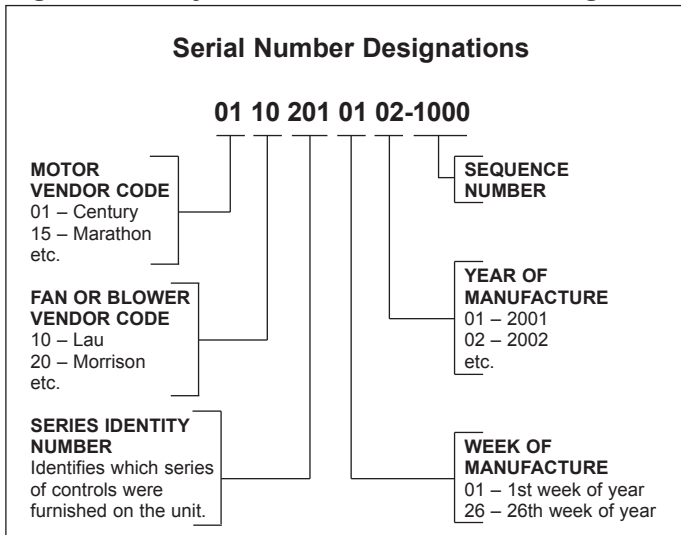

Figure 55.3 - System Unit Serial Number Designations ①



① Serial number format subject to change. When contacting the factory for replacement parts, always have the actual serial number ready from the unit(s).

START-UP CHECKLIST

START-UP CHECKLIST INDIRECT GAS-FIRED HEATING EQUIPMENT

Job Name:	Date:	
Address:	Model No.:	
City & State:	Order No.:	
Start-Up Check List "ALL ITEMS MUST BE CHECKED"	Serial No.:	
1. All shipping straps, braces, tie downs removed?	<input type="checkbox"/> Yes	<input type="checkbox"/> No
2. Unit installed level and secure?	<input type="checkbox"/> Yes	<input type="checkbox"/> No
3. Gas burner properly located and aligned?	<input type="checkbox"/> Yes	<input type="checkbox"/> No
4. Blower and motor alignment okay?	<input type="checkbox"/> Yes	<input type="checkbox"/> No
5. Bearings aligned and tight on shaft/bearing supports?	<input type="checkbox"/> Yes	<input type="checkbox"/> No
6. Electrical connections checked and secure?	<input type="checkbox"/> Yes	<input type="checkbox"/> No
7. Gas piping checked and tightened if necessary?	<input type="checkbox"/> Yes	<input type="checkbox"/> No
8. Any visible damage to unit? Describe: _____ If damaged, was the damage repaired?	<input type="checkbox"/> Yes	<input type="checkbox"/> No
9. Air inlet and discharge checked for obstructions?	<input type="checkbox"/> Yes	<input type="checkbox"/> No
10. Bearings checked for proper lubrication?	<input type="checkbox"/> Yes	<input type="checkbox"/> No
11. Filters in place and correct to direction of air flow?	<input type="checkbox"/> Yes	<input type="checkbox"/> No
12. Belt tension checked?	<input type="checkbox"/> Yes	<input type="checkbox"/> No
13. Electric supply to unit: _____ Volts, _____ Hz, _____ Phase		
14. Gas supply to unit: _____ Natural, _____ Propane		
15. Gas supply pressure to unit: _____ " W.C., _____ PSIG		
16. Inlet and/or discharge dampers operating correctly?	<input type="checkbox"/> Yes	<input type="checkbox"/> No
17. Blower rotation correct?	<input type="checkbox"/> Yes	<input type="checkbox"/> No
18. Blower speed: Hi Speed _____ RPM, Lo Speed _____ RPM		
19. Motor speed: Hi Speed _____ RPM, Lo Speed _____ RPM		
20. Is unit noisy? Excessive vibration?	<input type="checkbox"/> Yes	<input type="checkbox"/> No
21. Motor voltage: L1 _____ V, L2 _____ V, L3 _____ V		
22. Motor amps: L1 _____ Amp, L2 _____ Amp, L3 _____ Amp		
23. High temperature limit control continuity checked?	<input type="checkbox"/> Yes	<input type="checkbox"/> No
24. Burner light off Low Fire: Does entire burner light off? Hi Fire: Burner pressure reading? _____ " W.C. Is flame clean and stable? Does flame modulate in response to temperature control(s)?	<input type="checkbox"/> Yes <input type="checkbox"/> Yes <input type="checkbox"/> Yes <input type="checkbox"/> Yes	<input type="checkbox"/> No <input type="checkbox"/> No <input type="checkbox"/> No <input type="checkbox"/> No
25. Gas input checked? Input at maximum firing rate: _____ Btu/Hr Input at minimum firing rate: - _____ Btu/Hr	<input type="checkbox"/> Yes	<input type="checkbox"/> No
26. Gas piping checked for and free of leaks?	<input type="checkbox"/> Yes	<input type="checkbox"/> No
27. Has wiring been verified to match the unit wiring diagram?	<input type="checkbox"/> Yes	<input type="checkbox"/> No
28. Have all the modes of the sequence of operation been verified and tested?	<input type="checkbox"/> Yes	<input type="checkbox"/> No
29. What optional and/or accessory control devices have been set? Device: _____ Setting: _____ (°F/psi/Inches W.C./etc.) Device: _____ Setting: _____ (°F/psi/Inches W.C./etc.) Device: _____ Setting: _____ (°F/psi/Inches W.C./etc.)	<input type="checkbox"/> Yes <input type="checkbox"/> Yes <input type="checkbox"/> Yes	<input type="checkbox"/> No <input type="checkbox"/> No <input type="checkbox"/> No

Customer/Owner instructed in operation and maintenance of unit? Yes No

Name of Person(s) Instructed: _____

Comments: _____

Start-Up Company Name: _____ Phone: _____

Signature: _____ Date: _____

THIS PAGE INTENTIONALLY LEFT BLANK

THIS PAGE INTENTIONALLY LEFT BLANK

COMMERCIAL WARRANTY

Seller warrants its products to be free from defects in material and workmanship, EXCLUSIVE, HOWEVER, of failures attributable to the use of materials substituted under emergency conditions for materials normally employed. This warranty covers replacement of any parts furnished from the factory of Seller, but does not cover labor of any kind and materials not furnished by Seller, or any charges for any such labor or materials, whether such labor, materials or charges thereon are due to replacement of parts, adjustments, repairs, or any other work done. This warranty does not apply to any equipment which shall have been repaired or altered outside the factory of Seller in any way so as, in the judgment of Seller, to affect its stability, nor which has been subjected to misuse, negligence, or operating conditions in excess of those for which such equipment was designed. This warranty does not cover the effects of physical or chemical properties of water or steam or other liquids or gases used in the equipment.

BUYER AGREES THAT SELLER'S WARRANTY OF ITS PRODUCTS TO BE FREE FROM DEFECT IN MATERIAL AND WORKMANSHIP, AS LIMITED HEREIN, SHALL BE IN LIEU OF AND EXCLUSIVE OF ALL OTHER WARRANTIES, EITHER EXPRESS OR IMPLIED, WHETHER ARISING FROM LAW, COURSE OF DEALING, USAGE OF TRADE, OR OTHERWISE, **THERE ARE NO OTHER WARRANTIES, INCLUDING WARRANTY OF MERCHANTABILITY OR FITNESS FOR PURPOSE, WHICH EXTEND BEYOND THE PRODUCT DESCRIPTION CONFIRMED BY BUYER AND SELLER AS OF THE DATE OF FINAL AGREEMENT.**

This warranty is void if the input to the product exceeds the rated input as indicated on the product serial plate by more than 5% on gas-fired and oil-fired units, or if the product in the judgment of SELLER has been installed in a corrosive atmosphere, or subjected to corrosive fluids or gases, been subjected to misuse, negligence, accident, excessive thermal shock, excessive humidity, physical damage, impact, abrasion, unauthorized alterations, or operation contrary to SELLER'S printed instructions, or if the serial number has been altered, defaced or removed.

BUYER AGREES THAT IN NO EVENT WILL SELLER BE LIABLE FOR COSTS OF PROCESSING, LOST PROFITS, INJURY TO GOODWILL, OR ANY OTHER CONSEQUENTIAL OR INCIDENTAL DAMAGES OF ANY KIND RESULTING FROM THE ORDER OR USE OF ITS PRODUCT, WHETHER ARISING FROM BREACH OF WARRANTY, NONCONFORMITY TO ORDERED SPECIFICATIONS, DELAY IN DELIVERY, OR ANY LOSS SUSTAINED BY THE BUYER.

BUYER'S REMEDY FOR BREACH OF WARRANTY, EXCLUSIVE OF ALL OTHER REMEDIES PROVIDED BY LAW, IS LIMITED TO REPAIR OR REPLACEMENT AT THE FACTORY OF SELLER, ANY COMPONENT WHICH SHALL, WITHIN THE APPLICABLE WARRANTY PERIOD DEFINED HEREIN AND UPON PRIOR WRITTEN APPROVAL, BE RETURNED TO SELLER WITH TRANSPORTATION CHARGES PREPAID AND WHICH THE EXAMINATION OF SELLER SHALL DISCLOSE TO HAVE BEEN DEFECTIVE; EXCEPT THAT WHEN THE PRODUCT IS TO BE USED BY BUYER AS A COMPONENT PART OF EQUIPMENT MANUFACTURED BY BUYER, BUYER'S REMEDY FOR BREACH, AS LIMITED HEREIN, SHALL BE LIMITED TO ONE YEAR FROM DATE OF SHIPMENT FROM SELLER. FOR GAS-FIRED PRODUCTS INSTALLED IN HIGH HUMIDITY APPLICATIONS AND UTILIZING STAINLESS STEEL HEAT EXCHANGERS, BUYER'S REMEDY FOR BREACH, AS LIMITED HEREIN, SHALL BE LIMITED TO TEN YEARS FROM DATE OF SHIPMENT FROM SELLER.

These warranties are issued only to the original owner-user and cannot be transferred or assigned. No provision is made in these warranties for any labor allowance or field labor participation. Seller will not honor any expenses incurred in its behalf with regard to repairs to any of Seller's products. No credit shall be issued for any defective part returned without proper written authorization (including, but not limited to, model number, serial number, date of failure, etc.) and freight prepaid.

OPTIONAL SUPPLEMENTAL WARRANTY

Provided a supplemental warranty has been purchased, Seller extends the warranty herein for an additional four (4) years on certain compressors. Provided a supplemental warranty has been purchased, Seller extends the warranty herein for an additional four (4) years or nine (9) years on certain heat exchangers.

EXCLUSION OF CONSUMABLES & CONDITIONS BEYOND SELLER'S CONTROL

This warranty shall not be applicable to any of the following items: refrigerant gas, belts, filters, fuses and other items consumed or worn out by normal wear and tear or conditions beyond Seller's control, including (without limitation as to generality) polluted or contaminated or foreign matter contained in the air or water utilized for heat exchanger (condenser) cooling or if the failure of the part is caused by improper air or water supply, or improper or incorrect sizing of power supply.

<u>Component</u> Applicable Models	"APPLICABLE WARRANTY PERIOD"
<u>Heat Exchangers</u> Gas-Fired Units except MPR Models	TEN YEARS FROM DATE OF FIRST BENEFICIAL USE BY BUYER OR ANY OTHER USER, WITHIN TEN YEARS FROM DATE OF RESALE BY BUYER OR ANY OTHER USER, WITHIN TEN YEARS FROM DATE OF RESALE BY BUYER IN ANY UNCHANGED CONDITION, OR WITHIN ONE HUNDRED TWENTY-SIX MONTHS FROM DATE OF SHIPMENT FROM SELLER, WHICHEVER OCCURS FIRST
<u>Heat Exchangers</u> Low Intensity Infrared Units , Gas Heat option on MPR models <u>Compressors</u> Condensing Units for Cassettes	FIVE YEARS FROM DATE OF FIRST BENEFICIAL USE BY BUYER OR ANY OTHER USER, WITHIN FIVE YEARS FROM DATE OF RESALE BY BUYER OR ANY OTHER USER, WITHIN FIVE YEARS FROM DATE OF RESALE BY BUYER IN ANY UNCHANGED CONDITION, OR WITHIN SIXTY-SIX MONTHS FROM DATE OF SHIPMENT FROM SELLER, WHICHEVER OCCURS FIRST
<u>Burners</u> Low Intensity Infrared Units <u>Compressors</u> MPR Models <u>Other</u> Components excluding Heat Exchangers, Coils, Condensers, Burners, Sheet Metal	TWO YEARS FROM DATE OF FIRST BENEFICIAL USE BY BUYER OR ANY OTHER USER, WITHIN TWO YEARS FROM DATE OF RESALE BY BUYER IN ANY UNCHANGED CONDITION, OR WITHIN THIRTY MONTHS FROM DATE OF SHIPMENT FROM SELLER, WHICHEVER OCCURS FIRST
<u>Heat Exchangers/Coils</u> Indoor and Outdoor Duct Furnaces and System Units, Steam/Hot Water Units, Oil-Fired Units, Electric Units, Cassettes, Vertical Unit Ventilators <u>Compressors</u> Vertical Unit Ventilators <u>Burners</u> High Intensity Infrared Units <u>Sheet Metal Parts</u> All Products	ONE YEAR FROM DATE OF FIRST BENEFICIAL USE BY BUYER OR ANY OTHER USER, WITHIN ONE YEAR FROM DATE OF RESALE BY BUYER IN ANY UNCHANGED CONDITION, OR WITHIN EIGHTEEN MONTHS FROM DATE OF SHIPMENT FROM SELLER, WHICHEVER OCCURS FIRST

As Modine Manufacturing Company has a continuous product improvement program, it reserves the right to change design and specifications without notice.



Modine Manufacturing Company
1500 DeKoven Avenue
Racine, WI 53403
Phone: 1.800.828.4328 (HEAT)
www.modinehvac.com