

SECTION 9: PARTS

We do our best to stock replacement parts when possible, but we cannot guarantee that all parts shown are available for purchase. Call (800) 523-4777 or visit www.grizzly.com/parts to check for availability.

Frame & Bed

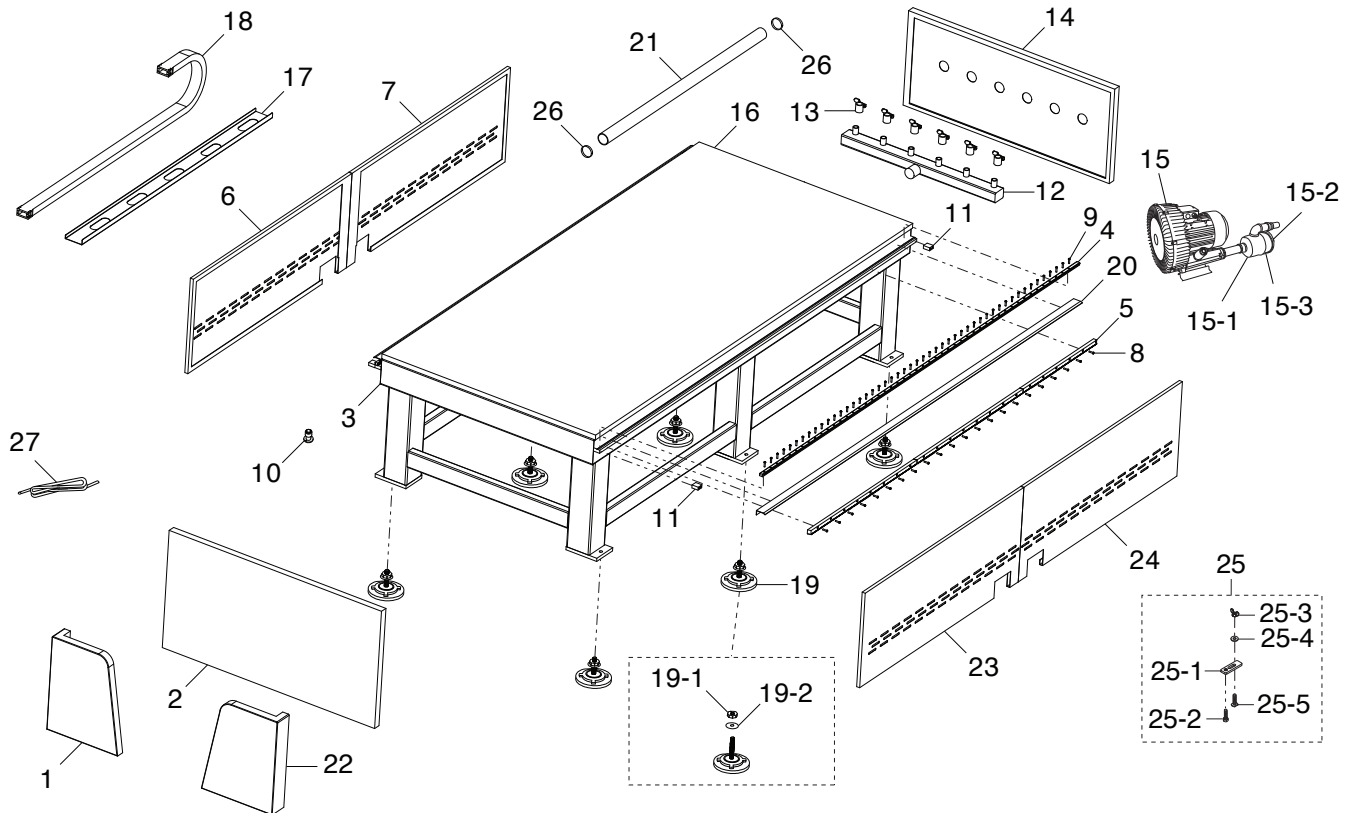

REF	PART #	DESCRIPTION
1	P0895001	CORNER COVER (LEFT)
2	P0895002	PANEL (FRONT)
3	P0895003	BODY
4	P0895004	LINEAR GUIDE 25MM
5	P0895005	RACK
6	P0895006	SIDE PANEL (LEFT, FRONT)
7	P0895007	SIDE PANEL (LEFT, REAR)
8	P0895008	CAP SCREW M6-1 X 30
9	P0895009	CAP SCREW M5-.8 X 25
10	P0895010	Z-AXIS SENSOR
11	P0895011	LIMIT BLOCK
12	P0895012	AIR DISTRIBUTION PIPE
13	P0895013	AIR VALVE
14	P0895014	PANEL (REAR)
15	P0895015	VACUUM PUMP
15-1	P0895015-1	VACUUM PUMP FILTER ASSEMBLY
15-2	P0895015-2	PLEXIGLASS COVER W/RUBBER SEAL
15-3	P0895015-3	VACUUM PUMP FILTER
16	P0895016	VACUUM TABLE

REF	PART #	DESCRIPTION
17	P0895017	CABLE SUPPORT
18	P0895018	CABLE CARRIER
19	P0895019	LEVELING FOOT
19-1	P0895019-1	HEX NUT M20-2.5
19-2	P0895019-2	FLAT WASHER 20MM
20	P0895020	DUST COVER
21	P0895021	VACUUM HOSE 2"
22	P0895022	CORNER COVER (RIGHT)
23	P0895023	SIDE PANEL (RIGHT, FRONT)
24	P0895024	SIDE PANEL (RIGHT, REAR)
25	P0895025	T-SLOT CLAMP
25-1	P0895025-1	T-SLOT CLAMP PLATE
25-2	P0895025-2	HEX BOLT M8-1.25 X 50
25-3	P0895025-3	WING NUT M8-1.25
25-4	P0895025-4	FLAT WASHER 8MM
25-5	P0895025-5	T-BOLT M8-1.25 X 80
26	P0895026	HOSE CLAMP 2"
27	P0895027	GASKET TUBE



Gantry & Spindle

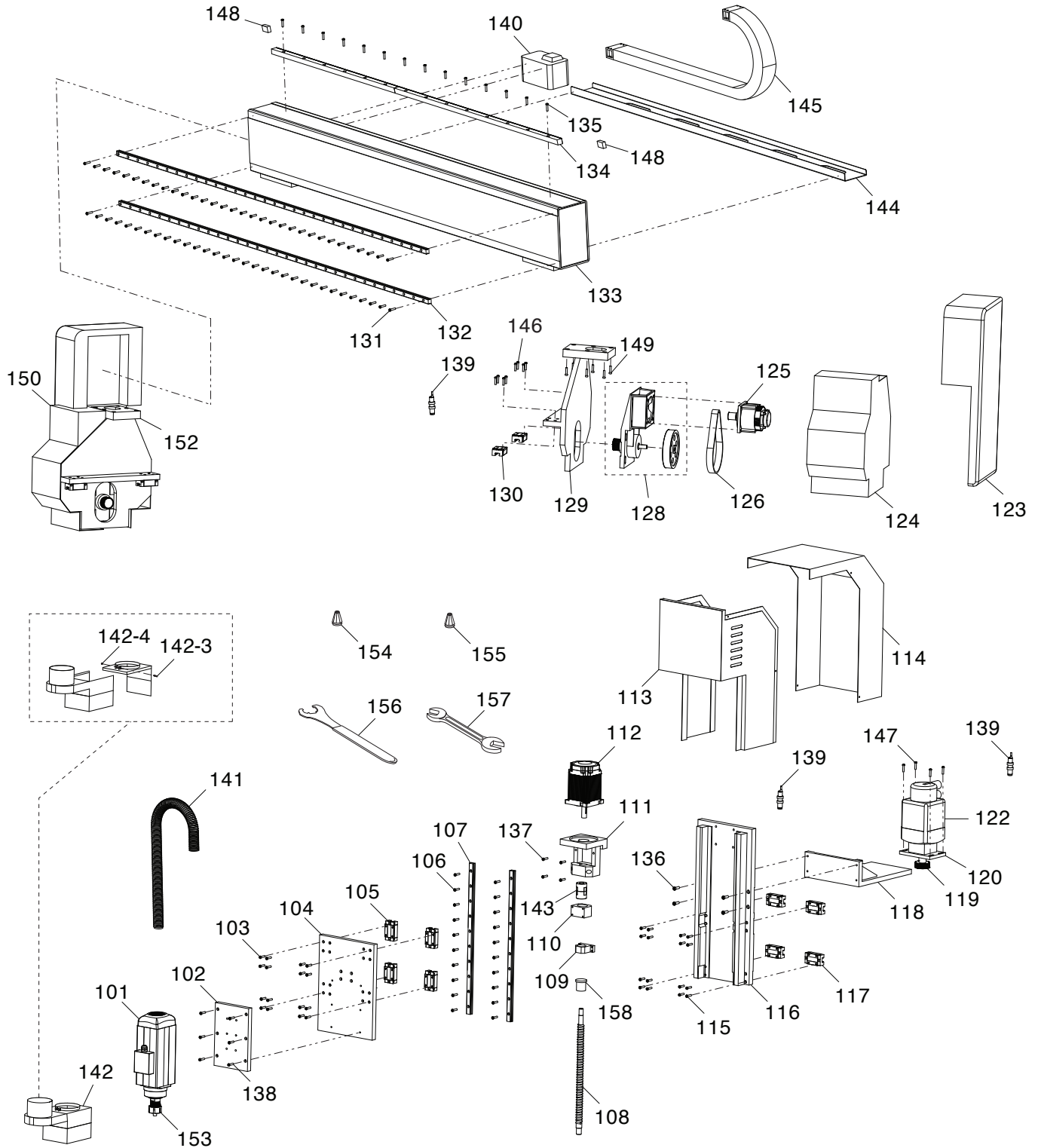

Gantry & Spindle Parts List

REF	PART #	DESCRIPTION
101	P0895101	SPINDLE MOTOR 6HP 3-PH 220V
102	P0895102	MOTOR MOUNT
103	P0895103	CAP SCREW M5-.8 X 20
104	P0895104	Z-AXIS MOUNT
105	P0895105	SLIDE BRACKET 25MM
106	P0895106	CAP SCREW M5-.8 X 25
107	P0895107	LINEAR GUIDE 25MM
108	P0895108	BALL SCREW 25MM
109	P0895109	BEARING SEAT
110	P0895110	BALL SCREW SEAT
111	P0895111	Z-AXIS MOTOR MOUNT
112	P0895112	Z-AXIS SERVO MOTOR SGM7G-09AFC6C
113	P0895113	SPINDLE COVER (LOWER)
114	P0895114	SPINDLE COVER (UPPER)
115	P0895115	CAP SCREW M5-.8 X 20
116	P0895116	X-AXIS MOUNT
117	P0895117	SLIDE BRACKET 25MM
118	P0895118	DRIVE BOARD BRACKET
119	P0895119	GEAR
120	P0895120	X-AXIS SERVO MOTOR MOUNTING BOARD
122	P0895122	X-AXIS SERVO MOTOR SGM7G-09AFC61
123	P0895123	Y-AXIS COVER (UPPER, RIGHT)
124	P0895124	Y-AXIS COVER (LOWER, RIGHT)
125	P0895125	Y-AXIS SERVO MOTOR SGM7G-09AFC61
126	P0895126	TIMING BELT 5M 550
128	P0895128	GEAR BOX & PULLEY
129	P0895129	GANTRY SUPPORT (RIGHT)
130	P0895130	SLIDE BRACKET 25MM
131	P0895131	CAP SCREW M5-.8 X 20

REF	PART #	DESCRIPTION
132	P0895132	LINEAR GUIDE 25MM
133	P0895133	GANTRY
134	P0895134	RACK
135	P0895135	CAP SCREW M6-1 X 25
136	P0895136	CAP SCREW M8-1.25 X 35
137	P0895137	CAP SCREW M6-1 X 45
138	P0895138	CAP SCREW M6-1 X 30
139	P0895139	LIMIT SWITCH TL-Q5MC1-Z
140	P0895140	LUBRICATION PUMP
141	P0895141	CONDUIT
142	P0895142	DUST HOOD ASSEMBLY
142-3	P0895142-3	CAP SCREW M5-.8 X 30
142-4	P0895142-4	HEX NUT M5-.8
143	P0895143	COUPLER
144	P0895144	CABLE CARRIER
145	P0895145	CABLE SUPPORT
146	P0895146	CAP SCREW M5-.8 X 20
147	P0895147	CAP SCREW M8-1.25 X 30
148	P0895148	LIMIT BLOCK
149	P0895149	CAP SCREW M12-1.75 X 60
150	P0895150	Y-AXIS COVERS 2-PC SET
152	P0895152	GANTRY SUPPORT (LEFT)
153	P0895153	SPINDLE NUT ER32
154	P0895154	COLLET 6MM ER32
155	P0895155	COLLET 1/2" ER32
156	P0895156	COLLET WRENCH ER32
157	P0895157	WRENCH 30 X 32 OPEN ENDS
158	P0895158	Z-AXIS SHAFT COLLAR



Electrical Cabinet

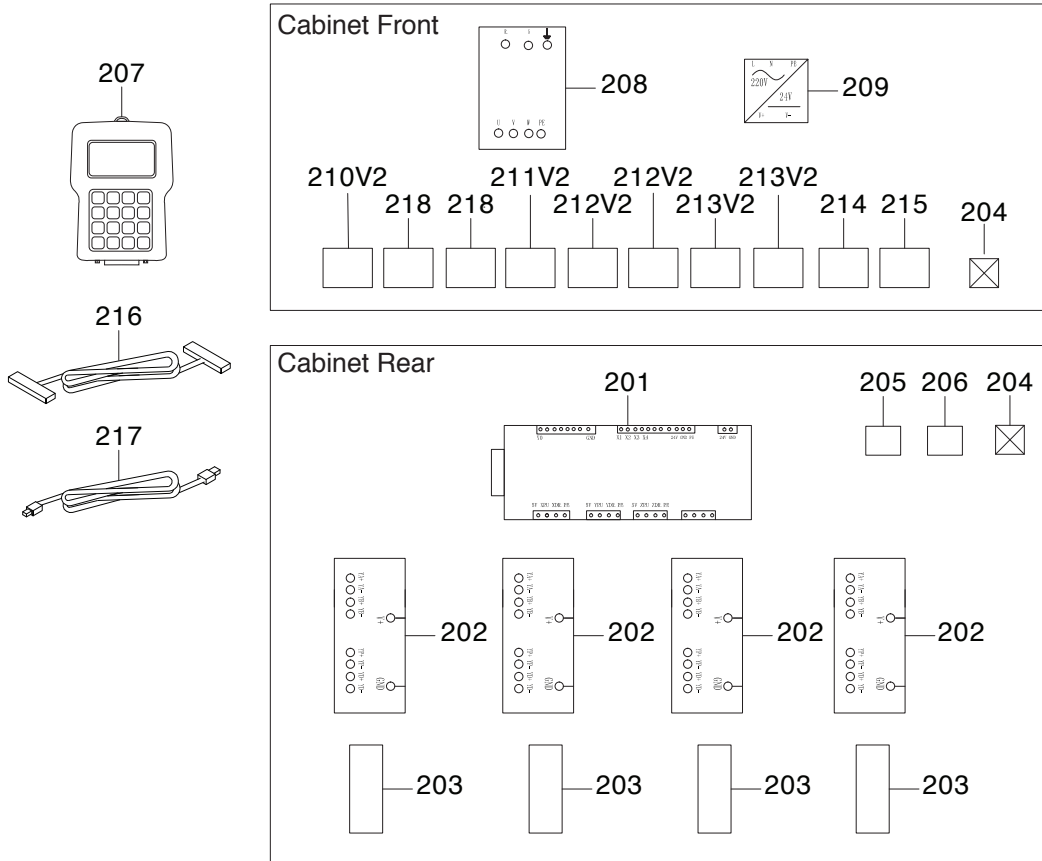

REF PART # DESCRIPTION

201	P0895201	DSP CONTROLLER RICHAUTO A11E
202	P0895202	SERVO MOTOR YASKAWA SGD7S-7R6A00A
203	P0895203	BRAKE RESISTANCE 200W
204	P0895204	FAN SUNON 2122HSL
205	P0895205	ON SWITCH YIJIA YJ136-LA38
206	P0895206	E-STOP SWITCH YIJIA YJ136-LA38
207	P0895207	DSP CONTROLLER RICHAUTO
208	P0895208	VFD DELTA MS300 VFD25AMS23ANSAA
209	P0895209	POWER CONVERTER LRS01-150-24D

REF PART # DESCRIPTION

210V2	P0895210V2	CIRCUIT BREAKER 32A IC65N V2.01.20
211V2	P0895211V2	CONTACTOR LC1R2510 V2.01.20
212V2	P0895212V2	TERMINAL BAR 4P V2.01.20
213V2	P0895213V2	TERMINAL BAR 6P V2.01.20
214	P0895214	RELAY OMRON MY2N-GS 24VDC
215	P0895215	POWER TERMINAL 6P
216	P0895216	CONTROLLER CABLE 50-PIN
217	P0895217	CONTROLLER CABLE USB
218	P0895218	FUSE 32A 690V RT18-32X



Labels & Cosmetics

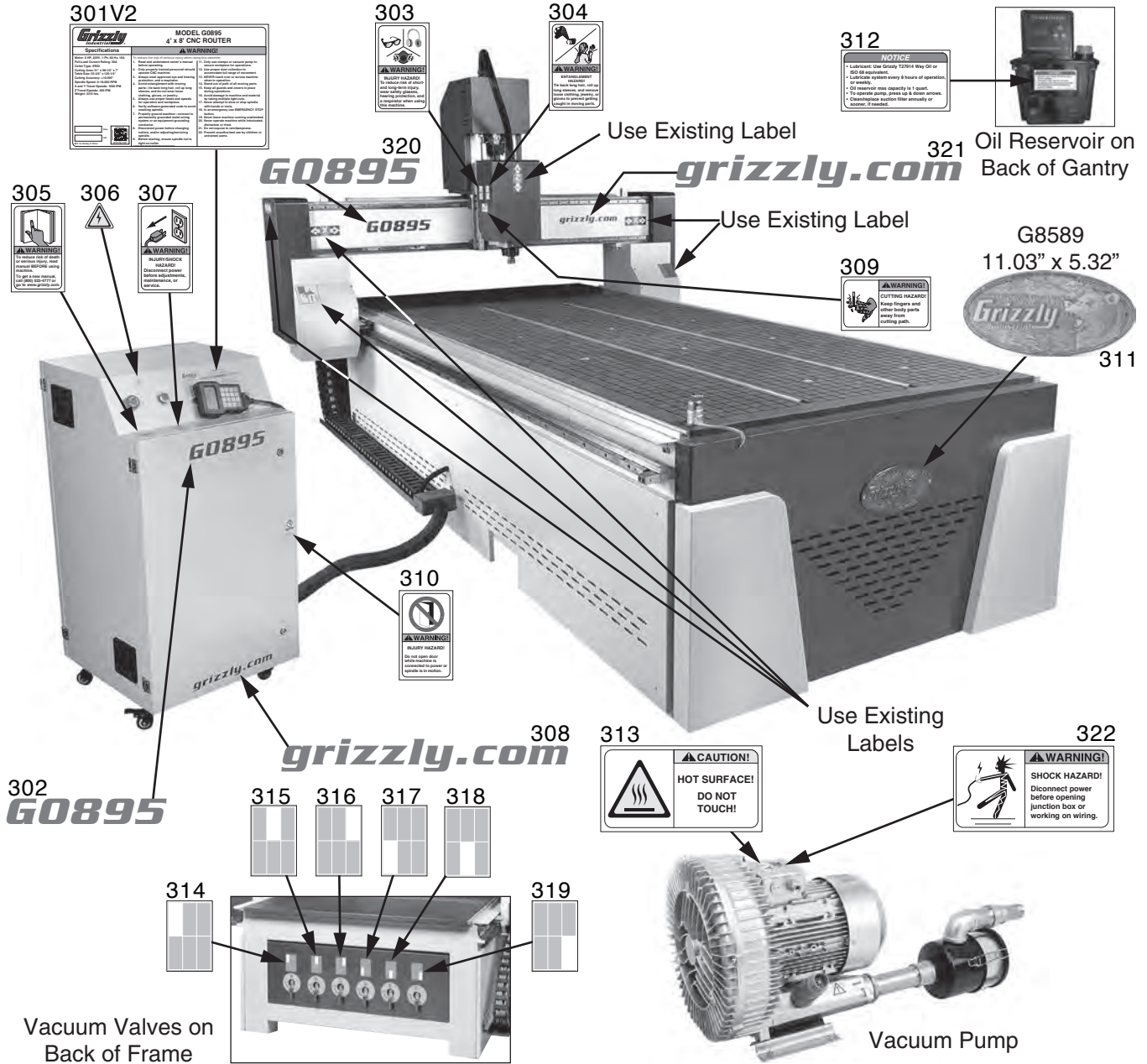

Labels & Cosmetics Parts List

REF	PART #	DESCRIPTION
301V2	P0895301V2	MACHINE ID LABEL V2.01.20
302	P0895302	MODEL NUMBER LABEL (SMALL)
303	P0895303	EYE/EAR/LUNG LABEL
304	P0895304	ENTANGLEMENT LABEL
305	P0895305	READ MANUAL LABEL
306	P0895306	ELECTRICITY LABEL
307	P0895307	DISCONNECT POWER LABEL
308	P0895308	GRIZZLY.COM LABEL (SMALL)
309	P0895309	CUTTING HAZARD LABEL
310	P0895310	DO NOT OPEN LABEL
311	P0895311	GRIZZLY NAMEPLATE (LARGE)

REF	PART #	DESCRIPTION
312	P0895312	OIL RESERVOIR LABEL
313	P0895313	HOT SURFACE LABEL
314	P0895314	VACUUM ZONE LABEL (TOP, LEFT)
315	P0895315	VACUUM ZONE LABEL (TOP, CENTER)
316	P0895316	VACUUM ZONE LABEL (TOP, RIGHT)
317	P0895317	VACUUM ZONE LABEL (BOTTOM, LEFT)
318	P0895318	VACUUM ZONE LABEL (BOTTOM, CENTER)
319	P0895319	VACUUM ZONE LABEL (BOTTOM, RIGHT)
320	P0895320	MODEL NUMBER LABEL (LARGE)
321	P0895321	GRIZZLY.COM LABEL (LARGE)
322	P0895322	DO NOT OPEN JUNCTION BOX LABEL

WARNING

Safety labels help reduce the risk of serious injury caused by machine hazards. If any label comes off or becomes unreadable, the owner of this machine **MUST** replace it in the original location before resuming operations. For replacements, contact (800) 523-4777 or www.grizzly.com.

