

71-8468-250

1/05

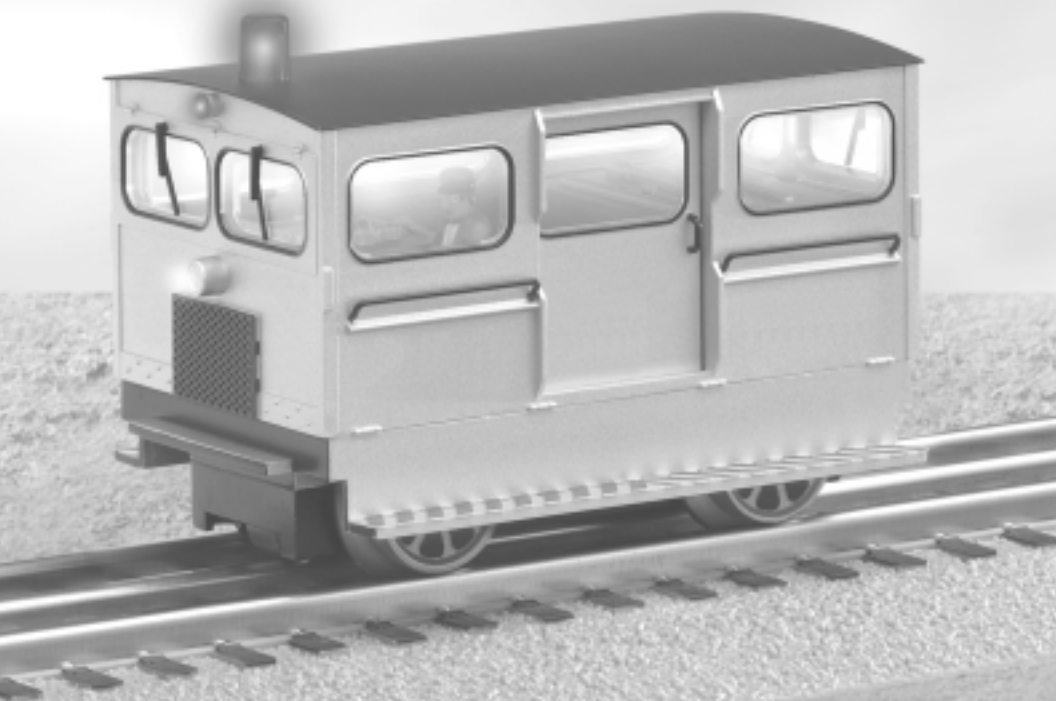

***Lionel
Railroad Speeder
Owner's Manual***

Congratulations!

Congratulations on your purchase of the Lionel Speeder! This motorized unit features two figures, a lighted interior, operating headlights, and a flashing strobe light.

Features of the speeder

- **Transformer controlled forward, neutral, and reverse operation**
- **Operating front and rear headlights**
- **Powerful, maintenance-free motor**
- **Traction tire**
- **Operating strobe light**
- **Interior lighting**
- **Two crew figures**

The following Lionel marks may be used throughout this instruction manual and are protected under law. All rights reserved.

Lionel®, *TrainMaster®*, *Odyssey®*, *RailSounds®*, *CrewTalk™*, *TowerCom™*, *DynaChuff™*, *StationSounds™*, *Pullmor®*, *ElectroCoupler™*, *Magne-Traction®*, *CAB-1® Remote Controller*, *PowerMaster®*, *Lionel ZW®*, *ZW®*, *PowerHouse®*, *TMCC®*, *Lionelville™*, *Lockon®*, *Wireless Tether™*, *LionMaster®*, *FatBoy™*, *American Flyer®*, *TrainSounds™*

The name FasTrack® is used with permission from Pitsco, Inc.

Table of contents

Transformer operations

Running your speeder with a Lionel transformer	4
Locking your speeder into a single operational state	5

Maintaining and servicing your speeder

Lubricating your speeder	6
Replacing your speeder's lamps	7
Replacing the traction tire	7
Limited Warranty/Lionel Service	8

Transformer operations

Running your speeder with a Lionel transformer

1

Place your speeder on Lionel or Lionel-compatible 0 gauge track.

2

Power up your speeder with your transformer.

Your speeder is designed to operate on 8-18 volts alternating current. Virtually all Lionel and Lionel-compatible alternating-current transformers are suitable.

Caution!

Do not power your speeder with direct current (DC). Damage to sensitive electronic components may occur.

3

Move 'em out!

Get your speeder moving. Press the DIRECTION button on your Lionel transformer. This sequences the reverse unit to the next operating state in the repeating sequence: forward, neutral, reverse, and neutral.

Adjust track voltage until your speeder moves at your desired speed. To increase speed, increase track voltage. To decrease speed, reduce voltage. To stop the speeder, turn-off track power.

See page 5 for information on locking your speeder into a single operational state.

Transformer operations

Locking your speeder into a single operational state

To select a single operational state for your Lionel speeder (for example, forward only), you can deactivate the reverse unit's sequencing function with the reverse unit switch.

To lock your speeder into a particular state, cycle the speeder through forward, neutral, reverse, neutral, and so on. Turn off track power and remove the speeder from the track when it operates in the state that precedes your desired state. For example, remove the speeder from the track when it is in neutral, just before forward. Throw the switch on the underside of the unit, place the unit back on the track, and the speeder is locked in the next operational state. Refer to Figure 1 for the switch location.

When you no longer want single-direction operation, just slide the switch back to ON.

Note! Your speeder's reverse unit will "reset" to forward after any power interruption lasting five seconds or longer, regardless of the original locked-out direction.

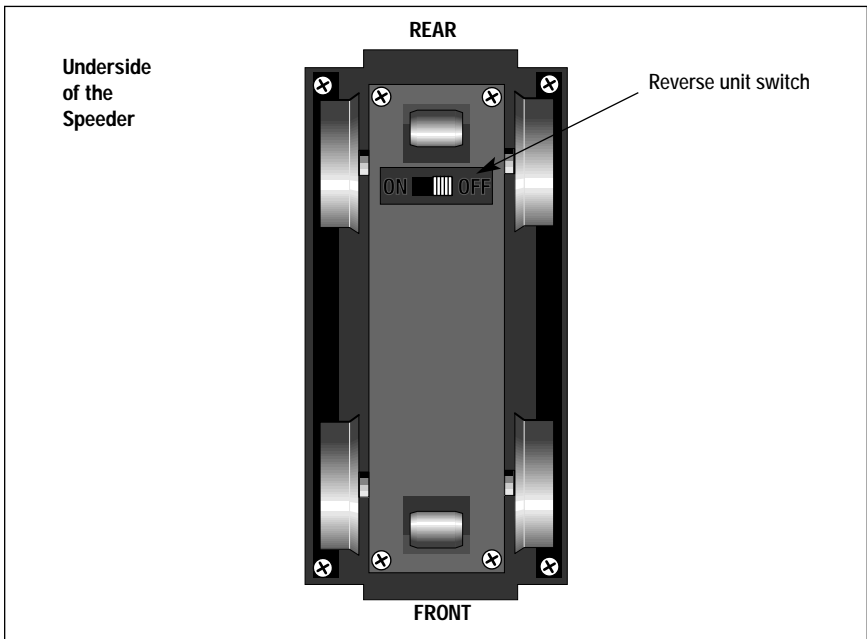

Figure 1. Switch location

Maintaining and servicing your speeder

Lubricating your speeder

Help your Lionel speeder lead a long and productive life on your railroad by maintaining it properly.

We recommend that you purchase a Lionel Lubrication and Maintenance Kit (6-62927), available from your Lionel dealer. Two basic rules to keep in mind: *never* over-lubricate (a small amount will do), and avoid getting grease or oil on the speeder's wheels *or* your track. You'll know your speeder requires lubrication when visual inspection reveals dryness on the parts indicated in Figure 4. Remove accumulated dirt and dust before lubricating and always lubricate any speeder emerging from prolonged storage.

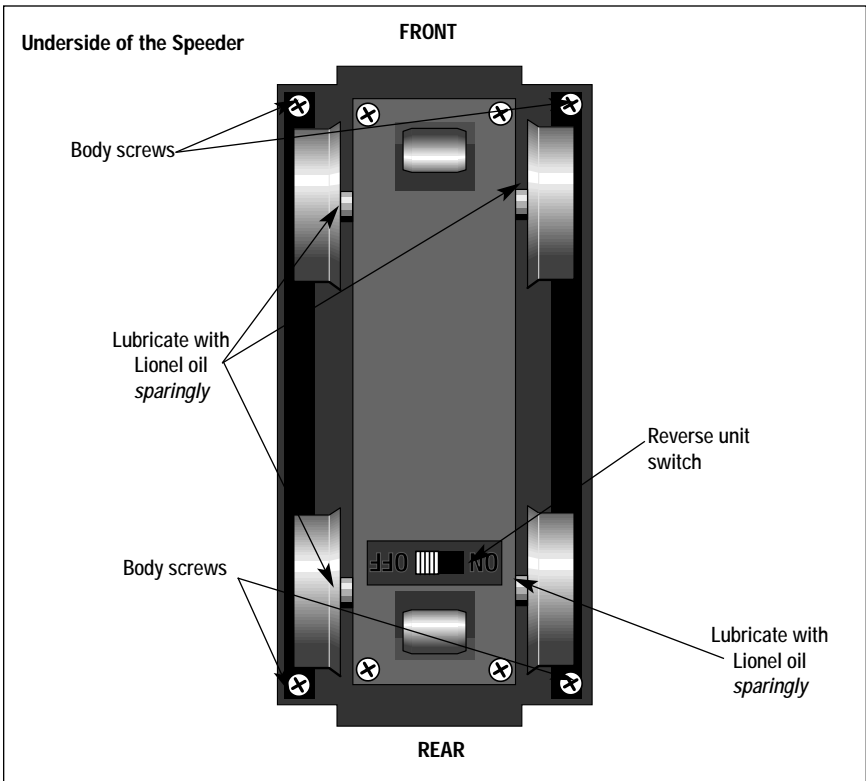

Figure 4. Underside details and lubrication points

Maintaining and servicing your speeder

Replacing your speeder's lamps

Your speeder is illuminated by two lamps and two LEDs (light emitting diodes). While the LEDs are expected to last for the life of the product, you may find that the lamps require replacement. Because of the delicate soldering operations required, we recommend that you have the lamps serviced at an authorized Lionel Service Center. Refer to the Service Center list that is included with this unit.

Replacing the traction tires

Your speeder is equipped with one traction tire, Lionel part no. 610-8468-206. During the course of normal operations, the traction tire may become worn out. To replace the traction tire, use a small flat-blade screwdriver to slip the worn tire off the wheel and position the replacement tire around the wheel. Carefully fit the tire into the groove. If you are uncomfortable with this operation, you may choose to have the traction tires replaced by your authorized Lionel Service Center.

Limited Warranty/Lionel Service

This Lionel product, including all mechanical and electrical components, moving parts, motors and structural components, except for light bulbs, is warranted to the original consumer-purchaser, for **one year** against original defects in materials or workmanship when purchased through an authorized Lionel merchant.

This warranty does NOT cover normal wear and tear, light bulbs, defects appearing in the course of commercial use, or damage resulting from abuse or misuse of the product by the purchaser. Transfer of this product by the original consumer-purchaser to another person voids this warranty. Modification of this product voids this warranty.

Any warranted product which is defective in original materials or workmanship and is delivered by the original consumer-purchaser to Lionel L.L.C. or an authorized Lionel L.L.C. Service Center, together with proof of original purchase will, at the option of Lionel L.L.C., be repaired or replaced, without charge for parts or labor. In the event the defective product cannot be repaired, and a replacement is not available, a refund of the original purchase price will be granted. Any products on which warranty service is sought must be sent freight or postage prepaid, as transportation and shipping charges are not covered by the warranty.

In no event shall Lionel L.L.C. be liable for incidental or consequential damages.

Some states do not allow the exclusion or limitation of incidental or consequential damages, so the above exclusion may not apply to you.

This limited warranty gives you specific legal rights, and you may have other rights which vary from state to state.

Instructions for Obtaining Service

If service for this Lionel L.L.C. product is required, bring the item, along with your dated sales receipt and completed warranty information to the nearest Authorized Lionel Service Center. Your nearest Lionel Service Center can be found by calling 1-800-4-Lionel, or by accessing our Website at www.lionel.com.

If you prefer to send your product back to Lionel L.L.C. for repair in Michigan, you must first call 586-949-4100 or FAX 586-949-5429, or write to Customer Service, P.O. Box 748, New Baltimore, MI 48047-0748, stating what the item is, when it was purchased and what seems to be the problem. You will be sent a return authorization letter and label to ensure your merchandise will be properly handled upon receipt.

Once you have received your return authorization and label, make sure that the item is packed to prevent damage during shipping and handling. We suggest that you use the product's original packaging. This shipment must be prepaid and we recommend that it be insured.

Please make sure you have followed all of the above instructions carefully before returning any merchandise for service. You may choose to have your product repaired by one of our Authorized Lionel Service Centers after its warranty has expired. A reasonable service fee will be charged.

Warranty Information

Please complete the information below and keep it, along with your dated sales receipt. You must present this and your dated sales receipt when requesting warranty service.

Name _____

Address _____

Place of Purchase _____

Date of Purchase _____

Product Number _____

Product Description _____



©2005 LIONEL L.L.C., CHESTERFIELD, MI 48051-2493
UNITED STATES OF AMERICA
PRINTED IN CHINA