



**Count on it.**

Form No. 01088SL Rev L

**Service Manual**

**Groundsmaster® 3500-D**  
**(Models 30821, 30839 and 30843)**



# Reader Comments

The Toro Company Technical Assistance Center maintains a continuous effort to improve the quality and usefulness of its publications. To do this effectively, we encourage user feedback. Please comment on the completeness, accuracy, organization, usability, and readability of this manual by an e-mail to [servicemanuals@toro.com](mailto:servicemanuals@toro.com)

or Mail to:

**Technical Publication Manager, Commercial  
The Toro Company  
8111 Lyndale Avenue South  
Bloomington, MN 55420-1196  
Phone: +1 952-887-8495**

# NOTES

---





## Service Manual

# Groundsmaster<sup>®</sup> 3500-D

## Models 30821, 30839 and 30843

### Preface

The purpose of this publication is to provide the service technician with information for troubleshooting, testing, and repair of major systems and components on the Groundsmaster 3500-D (Models 30821, 30839 and 30843).

REFER TO THE OPERATOR'S MANUAL FOR OPERATING, MAINTENANCE AND ADJUSTMENT INSTRUCTIONS. For reference, insert a copy of the Operator's Manual and Parts Catalog for your machine into Chapter 2 of this service manual. Additional copies of the Operator's Manual and Parts Catalog are available on the internet at [www.Toro.com](http://www.Toro.com).

The Toro Company reserves the right to change product specifications or this publication without notice.



This safety symbol means **DANGER, WARNING, or CAUTION, PERSONAL SAFETY INSTRUCTION**. When you see this symbol, carefully read the instructions that follow. Failure to obey the instructions may result in personal injury.

**NOTE:** A **NOTE** will give general information about the correct operation, maintenance, service, testing, or repair of the machine.

**IMPORTANT:** The **IMPORTANT** notice will give important instructions which must be followed to prevent damage to systems or components on the machine.



This page is intentionally blank.

# Table Of Contents

## Chapter 1 - Safety

General Safety Instructions	1 - 1
Jacking Instructions	1 - 4
Safety and Instruction Decals	1 - 5

## Chapter 2 - Product Records and Maintenance

Product Records	2 - 1
Maintenance	2 - 1
Equivalents and Conversions	2 - 2
Torque Specifications	2 - 3

## Chapter 3 - Kubota Diesel Engine

Introduction	3 - 2
Specifications	3 - 3
General Information	3 - 4
Adjustments	3 - 6
Service and Repairs	3 - 8
KUBOTA WORKSHOP MANUAL, DIESEL ENGINE, 05 SERIES	

## Chapter 4 - Hydraulic System

Specifications	4 - 2
General Information	4 - 3
Hydraulic Schematic	4 - 9
Hydraulic Flow Diagrams	4 - 10
Special Tools	4 - 22
Troubleshooting	4 - 26
Testing	4 - 28
Adjustments	4 - 54
Service and Repairs	4 - 56
ROSS TORQMOTOR™ MG, MF, ME, AND MJ SERIES SERVICE PROCEDURE	
EATON MEDIUM DUTY PISTON PUMP REPAIR INFORMATION MODEL 70160 VARIABLE DISPLACEMENT PISTON PUMP	
ROSS HYDRAGUIDE™ HYDROSTATIC STEERING SYSTEM HGF SERIES SERVICE PROCEDURE	
DANFOSS STEERING UNIT TYPE OSPM SERVICE MANUAL	

## Chapter 5 - Electrical System

Electrical Schematics and Diagrams	5 - 2
Special Tools	5 - 3
Troubleshooting	5 - 4
Electrical System Quick Checks	5 - 7
Component Testing	5 - 9
Service and Repairs	5 - 24

## Chapter 6 - Wheels, Brakes, and Chassis

Specifications	6 - 2
Special Tools	6 - 2
Adjustments	6 - 3
Service and Repairs	6 - 8

## Chapter 7 - Cutting Units

Specifications	7 - 2
Troubleshooting	7 - 3
Special Tools	7 - 4
Adjustments	7 - 5
Service and Repairs	7 - 8

## Chapter 8 - Electrical Diagrams

Electrical Schematics and Diagrams	8 - 3
------------------------------------	-------

Safety
Product Records and Maintenance
Kubota Diesel Engine
Hydraulic System
Electrical System
Wheels, Brakes, and Chassis
Cutting Units
Electrical Diagrams

This page is intentionally blank.



## Table of Contents

GENERAL SAFETY INSTRUCTIONS .....	1	Maintenance and Service .....	3
Before Operating .....	1	JACKING INSTRUCTIONS .....	4
While Operating .....	2	SAFETY AND INSTRUCTION DECALS .....	5

## General Safety Instructions

The GROUNDMASTER 3500- D was tested and certified by TORO for compliance with existing standards and specifications as identified in the Operator's Manual. Although hazard control and accident prevention are dependent partially upon the design and configuration of the machine, these factors are also dependent upon the awareness, concern, and proper training of the personnel involved in the operation, transport, maintenance, and storage of the machine. Improper use or maintenance by the operator or owner of the machine can result in injury. To reduce the potential for any injury, comply with the following safety instructions.

**WARNING**

**To reduce the potential for injury or death, comply with the following safety instructions.**

### Before Operating

1. Operate machine only after reading and understanding the contents of the Operator's Manual and viewing the Operator's Video. Copies of the Operator's Manual are available on the internet at [www.Toro.com](http://www.Toro.com).
2. Only trained operators who are skilled in slope operation and who have read the Operator's Manual and viewed the Operator's Video should operate the machine. Never allow children to operate the machine or adults to operate it without proper instructions.
3. Become familiar with the controls and know how to stop the machine and engine quickly.
4. Do not carry passengers on the machine. Keep everyone, especially children and pets, away from the areas of operation.
5. Keep all shields, safety devices, and decals in place. Repair or replace damaged, malfunctioning, or illegible shields, safety devices, or decals before operating the machine.
6. Always wear substantial shoes. Do not operate machine while wearing sandals, tennis shoes or sneakers. Do not wear loose fitting clothing because it could get caught in moving parts and possibly cause personal injury.
7. Wearing safety glasses, safety shoes, long pants and a helmet is advisable and required by some local ordinances and insurance regulations.
8. Make sure the work area is clear of objects which might be picked up and thrown by the blades.
9. Fill fuel tank with diesel fuel before starting engine. Avoid spilling any fuel. Since fuel is highly flammable, handle it carefully.
  - A. Use an approved fuel container.
  - B. Do not remove cap from fuel tank when engine is hot or running.
  - C. Do not smoke while handling diesel fuel.
  - D. Fill fuel tank outdoors and not over one inch from the top of the tank (bottom of the filler neck). Do not overfill.

---

## While Operating

1. Always wear your seat belt.
2. Do not run the engine in a confined area without adequate ventilation. Exhaust fumes are hazardous and could be deadly.
3. Sit on the seat when starting and operating the machine.
4. Check interlock switches daily for proper operation (see Chapter 5 - Electrical System). Do not rely entirely on safety switches: shut off engine before getting off seat. If a switch fails, replace it before operating the machine. The interlock system is for your protection, so do not bypass it.
5. Operator must be skilled and trained in how to drive on hillsides. Failure to use caution on slopes or hills may cause vehicle to tip or roll, possibly resulting in personal injury or death.
6. This triplex mower has a unique drive system for superior traction on hills. The uphill wheel will not spin out and limit traction like conventional triplexes. If operated on a side hill that is too steep, rollover may occur before losing traction.
7. Before backing up, look to the rear and assure no one is behind the machine. Watch out for traffic when near or crossing roads. Always yield the right of way.
8. Keep hands, feet and clothing away from moving parts and the deck discharge area.
9. Establish special procedures and work rules for unusual operating conditions (e.g. slopes, sand traps, water hazards). Survey the mowing site completely to determine which areas can be operated on safely. When performing this site survey, always use common sense and take into consideration the turf condition and the rollover risk. To perform a site survey, follow the procedure outlined in the Operator's Manual.

Stay alert for holes in terrain and other hidden hazards which can cause a sudden change in side hill angle. Use extreme caution when operating close to sand traps, ditches, creeks, steep hillsides, or other hazards. Reduce speed when making sharp turns. Do not turn on hills. Avoid sudden stops and starts. Use reverse pedal for braking. Cutting units should be lowered when going down slopes.

### 10. When starting the engine:

- A. Engage parking brake.
- B. Be sure traction pedal is in neutral and blade drive is in disengage position.
- C. After engine starts, release parking brake and keep foot off traction pedal. Machine must not move. If movement is evident, the neutral control linkage is incorrectly adjusted: therefore, shut engine off and adjust until machine does not move when traction pedal is released (see Adjust Traction Drive for Neutral in the Adjustments section of Chapter 4 - Hydraulic System).

11. This product may exceed noise levels of 85 dB(A) at the operator position. Ear protectors are recommended for prolonged exposure to reduce the potential of permanent hearing damage.

12. Raise the cutting units when driving from one work area to another.

13. Do not touch engine, muffler, exhaust pipe or hydraulic tank while engine is running or soon after it has stopped because these areas could be hot enough to cause burns.

14. If a cutting unit strikes a solid object or vibrates abnormally, stop immediately. Turn engine off, wait for all motion to stop and inspect for damage.

### 15. Before getting off the seat:

- A. Move traction pedal to neutral.
- B. Set the parking brake.
- C. Disengage the cutting units and wait for the blades to stop spinning.
- D. Stop the engine and remove key from the ignition switch.

16. Whenever machine is left unattended, make sure key is removed from ignition switch and parking brake is set.

---

## Maintenance and Service

1. Before servicing or making adjustments to the machine, stop the engine and remove key from switch to prevent accidental starting of the engine.
2. Check performance of all interlock switches daily. Do not defeat interlock system. It is for your protection.
3. To ensure entire machine is in good operating condition, frequently check and keep all nuts, bolts, screws and hydraulic fittings tight.
4. Make sure all hydraulic line connectors are tight, and all hydraulic hoses and lines are in good condition before applying pressure to the system.
5. Keep body and hands away from pin hole leaks or nozzles that eject hydraulic fluid under high pressure. Use paper or cardboard, not hands, to search for leaks. Hydraulic fluid escaping under pressure can have sufficient force to penetrate skin and do serious damage. If fluid is injected into the skin it must be surgically removed within a few hours by a doctor familiar with this form of injury or gangrene may result.
6. Before disconnecting or performing any work on the hydraulic system, all pressure in system must be relieved by stopping engine and lowering cutting units to the ground.
7. If major repairs are ever needed, or if assistance is desired, contact an Authorized Toro Distributor.
8. To reduce potential fire hazard, keep the engine area free of excessive grease, grass, leaves and accumulation of dirt.
9. If the engine must be running to perform a maintenance adjustment, keep hands, feet, clothing, and any other parts of the body away from the cutting units and any moving parts. Keep everyone away.
10. Do not overspeed the engine by changing governor settings. To assure safety and accuracy, have an Authorized Toro Distributor check maximum engine speed with a tachometer.
11. Engine must be shut off before checking oil or adding oil to the crankcase.
12. To insure optimum performance and safety, use genuine TORO replacement parts and accessories. Replacement parts and accessories made by other manufacturers could be dangerous, and such use could void the product warranty of The Toro Company.

# Jacking Instructions



## CAUTION

When changing attachments, tires, or performing other service, use correct blocks, hoists, and jacks. Make sure machine is parked on a solid level floor such as a concrete floor. Prior to raising machine, remove any attachments that may interfere with the safe and proper raising of the machine. Always chock or block wheels. Use jack stands or solid wood blocks to support the raised machine. If the machine is not properly supported by blocks or jack stands, the machine may move or fall, which may result in personal injury.

Use the following positions when jacking up the machine:

### Jacking the Front End

1. If the front wheel motor is to be removed, position jack securely under the square tube of the lower frame as closely to the side plate as possible (Fig. 1).
2. If the front tire is to be removed, position the jack securely under the front wheel motor.
3. Use jack stands or hardwood blocks under the square tube or wheel motors to support the machine.

### Jacking the Rear End

1. The preferred method for removing the rear fork, the rear wheel, or the rear wheel motor is to lift the rear end of the machine from above:
  - A. Secure a chain fall or hoist to the rear casting (Fig 2).
  - B. Chock both front tires. Lift rear tire off the ground.
  - C. Use jack stands or hardwood blocks under the frame to support the machine (Fig. 3).
2. If the rear of the machine cannot be lifted from above:
  - A. Chock both front tires.

**IMPORTANT: Make sure jack is as close to the rear fork as possible when jacking the rear wheel.**

- B. Place jack securely under the rear wheel motor as close to the fork as possible (Fig. 3). Jack rear tire off the ground.
- C. Use jack stands or blocks under the frame to support the machine.

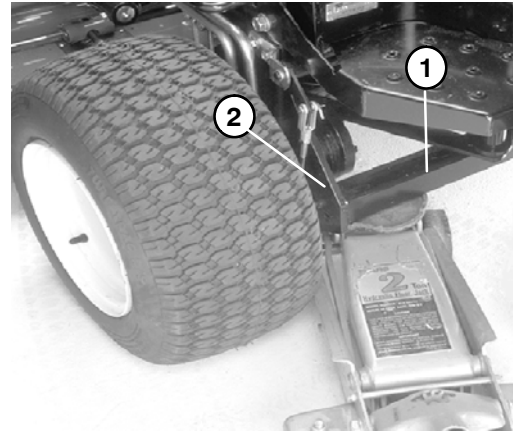

Figure 1

1. Square tube
2. Side plate

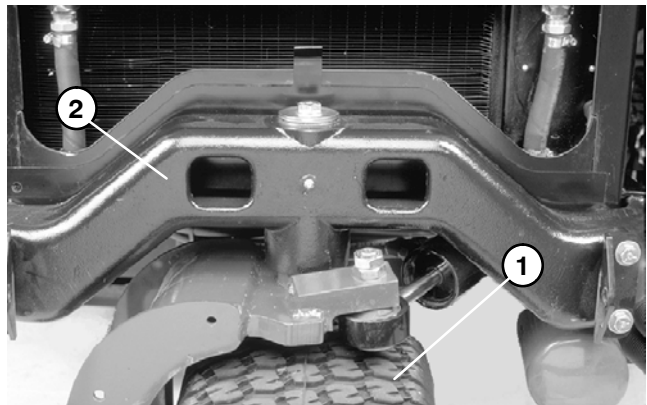

Figure 2

1. Rear tire
2. Rear casting

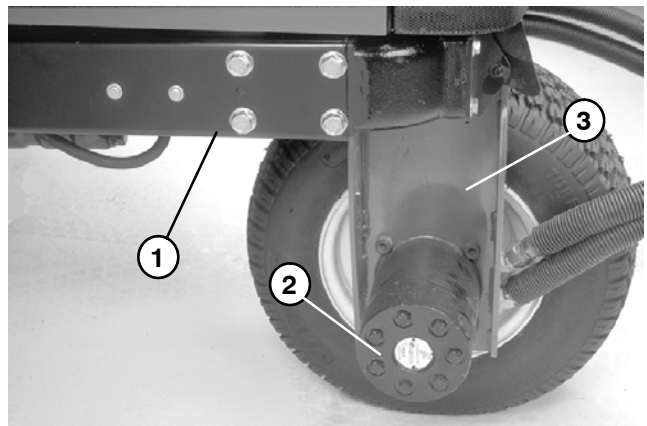

Figure 3

1. Frame
2. Rear wheel motor
3. Rear fork



# Safety and Instruction Decals

Numerous safety and instruction decals are affixed to the Groundsmaster 3500- D. If any decal becomes illegible or damaged, install a new decal. Part numbers for replacement decals are listed in your Parts Catalog. Order replacement decals from your Authorized Toro Distributor.

This page is intentionally blank.



# Product Records and Maintenance

## Table of Contents

PRODUCT RECORDS ..... 1  
 MAINTENANCE ..... 1  
 EQUIVALENTS AND CONVERSIONS ..... 2  
   Decimal and Millimeter Equivalents ..... 2  
   U.S. to Metric Conversions ..... 2  
 TORQUE SPECIFICATIONS ..... 3  
   Fastener Identification ..... 3  
   Using a Torque Wrench with an Offset Wrench .. 3  
   Standard Torque (Inch Series) ..... 4  
   Standard Torque (Metric Fasteners) ..... 5  
   Other Torque Specifications ..... 6  
   Conversion Factors ..... 6

## Product Records

Insert a copy of the Operator’s Manual and Parts Catalog for your Groundsmaster 3500- D at the end of this chapter. Additionally, if any optional equipment or accessories have been installed to your Groundsmaster, insert the Installation Instructions, Operator’s Manuals and Parts Catalogs for those options at the end of this chapter.

## Maintenance

Maintenance procedures and recommended service intervals for the Groundsmaster 3500- D are covered in the Operator’s Manual. Refer to that publication when performing regular equipment maintenance.

# Equivalents and Conversions

## Decimal and Millimeter Equivalents

Fractions	Decimals	mm	Fractions	Decimals	mm		
	1/64	0.015625	— 0.397	33/64	0.515625	— 13.097	
	1/32	0.03125	— 0.794	17/32	0.53125	— 13.494	
	3/64	0.046875	— 1.191	35/64	0.546875	— 13.891	
1/16	—	0.0625	— 1.588	9/16	—	0.5625	— 14.288
	5/64	0.078125	— 1.984	37/64	0.578125	— 14.684	
	3/32	0.09375	— 2.381	19/32	—	0.59375	— 15.081
	7/64	0.109275	— 2.778	39/64	0.609375	— 15.478	
1/8	—	0.1250	— 3.175	5/8	—	0.6250	— 15.875
	9/64	0.140625	— 3.572	41/64	0.640625	— 16.272	
	5/32	0.15625	— 3.969	21/32	—	0.65625	— 16.669
	11/64	0.171875	— 4.366	43/64	0.671875	— 17.066	
3/16	—	0.1875	— 4.762	11/16	—	0.6875	— 17.462
	13/64	0.203125	— 5.159	45/64	0.703125	— 17.859	
	7/32	0.21875	— 5.556	23/32	—	0.71875	— 18.256
	15/64	0.234375	— 5.953	47/64	0.734375	— 18.653	
1/4	—	0.2500	— 6.350	3/4	—	0.7500	— 19.050
	17/64	0.265625	— 6.747	49/64	0.765625	— 19.447	
	9/32	0.28125	— 7.144	25/32	—	0.78125	— 19.844
	19/64	0.296875	— 7.541	51/64	0.796875	— 20.241	
5/16	—	0.3125	— 7.938	13/16	—	0.8125	— 20.638
	21/64	0.328125	— 8.334	53/64	0.828125	— 21.034	
	11/32	0.34375	— 8.731	27/32	—	0.84375	— 21.431
	23/64	0.359375	— 9.128	55/64	0.859375	— 21.828	
3/8	—	0.3750	— 9.525	7/8	—	0.8750	— 22.225
	25/64	0.390625	— 9.922	57/64	0.890625	— 22.622	
	13/32	0.40625	— 10.319	29/32	—	0.90625	— 23.019
	27/64	0.421875	— 10.716	59/64	0.921875	— 23.416	
7/16	—	0.4375	— 11.112	15/16	—	0.9375	— 23.812
	29/64	0.453125	— 11.509	61/64	0.953125	— 24.209	
	15/32	0.46875	— 11.906	31/32	—	0.96875	— 24.606
	31/64	0.484375	— 12.303	63/64	0.984375	— 25.003	
1/2	—	0.5000	— 12.700	1	—	1.000	— 25.400
	<b>1 mm = 0.03937 in.</b>			<b>0.001 in. = 0.0254 mm</b>			

## U.S. to Metric Conversions

	To Convert	Into	Multiply By
<b>Linear Measurement</b>	Miles	Kilometers	1.609
	Yards	Meters	0.9144
	Feet	Meters	0.3048
	Feet	Centimeters	30.48
	Inches	Meters	0.0254
	Inches	Centimeters	2.54
	Inches	Millimeters	25.4
<b>Area</b>	Square Miles	Square Kilometers	2.59
	Square Feet	Square Meters	0.0929
	Square Inches	Square Centimeters	6.452
	Acre	Hectare	0.4047
<b>Volume</b>	Cubic Yards	Cubic Meters	0.7646
	Cubic Feet	Cubic Meters	0.02832
	Cubic Inches	Cubic Centimeters	16.39
<b>Weight</b>	Tons (Short)	Metric Tons	0.9078
	Pounds	Kilograms	0.4536
	Ounces (Avdp.)	Grams	28.3495
<b>Pressure</b>	Pounds/Sq. In.	Kilopascal	6.895
	Pounds/Sq. In.	Bar	0.069
<b>Work</b>	Foot-pounds	Newton-Meters	1.356
	Foot-pounds	Kilogram-Meters	0.1383
	Inch-pounds	Kilogram-Centimeters	1.152144
<b>Liquid Volume</b>	Quarts	Liters	0.9463
	Gallons	Liters	3.785
<b>Liquid Flow</b>	Gallons/Minute	Liters/Minute	3.785
<b>Temperature</b>	Fahrenheit	Celsius	1. Subtract 32°
			2. Multiply by 5/9

# Torque Specifications

Recommended fastener torque values are listed in the following tables. For critical applications, as determined by Toro, either the recommended torque or a torque that is unique to the application is clearly identified and specified in this Service Manual.

These Torque Specifications for the installation and tightening of fasteners shall apply to all fasteners which do not have a specific requirement identified in this Service Manual. The following factors shall be considered when applying torque: cleanliness of the fastener, use of a thread sealant (Loctite), degree of lubrication on the fastener, presence of a prevailing torque feature, hardness of the surface underneath the fastener's head, or similar condition which affects the installation.

As noted in the following tables, torque values should be **reduced by 25% for lubricated fasteners** to achieve the similar stress as a dry fastener. Torque values may also have to be reduced when the fastener is threaded into aluminum or brass. The specific torque value should be determined based on the aluminum or brass material strength, fastener size, length of thread engagement, etc.

The standard method of verifying torque shall be performed by marking a line on the fastener (head or nut) and mating part, then back off fastener 1/4 of a turn. Measure the torque required to tighten the fastener until the lines match up.

## Fastener Identification

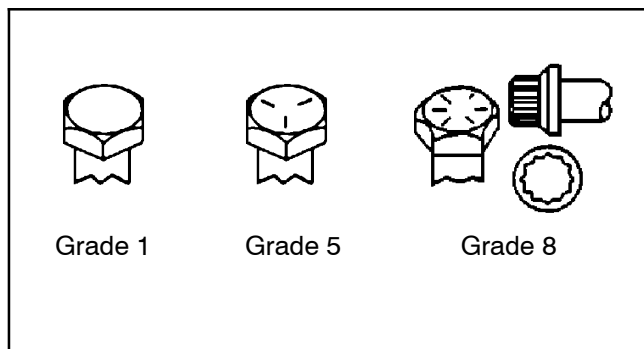

Inch Series Bolts and Screws

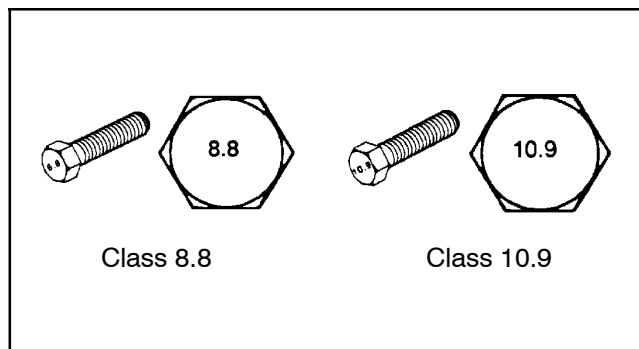

Metric Bolts and Screws

## Using a Torque Wrench with an Offset Wrench

Use of an offset wrench (e.g. crowfoot wrench) will affect torque wrench calibration due to the effective change of torque wrench length. When using a torque wrench with an offset wrench, multiply the listed torque recommendation by the calculated torque conversion factor (Fig. 4) to determine proper tightening torque. Tightening torque when using a torque wrench with an offset wrench will be lower than the listed torque recommendation.

**Example:** The measured effective length of the torque wrench (distance from the center of the handle to the center of the square drive) is 18".

The measured effective length of the torque wrench with the offset wrench installed (distance from the center of the handle to the center of the offset wrench) is 19".

The calculated torque conversion factor for this torque wrench with this offset wrench would be  $18 / 19 = 0.947$ .

If the listed torque recommendation for a fastener is from 76 to 94 ft-lb, the proper torque when using this torque wrench with an offset wrench would be from 72 to 89 ft-lb.

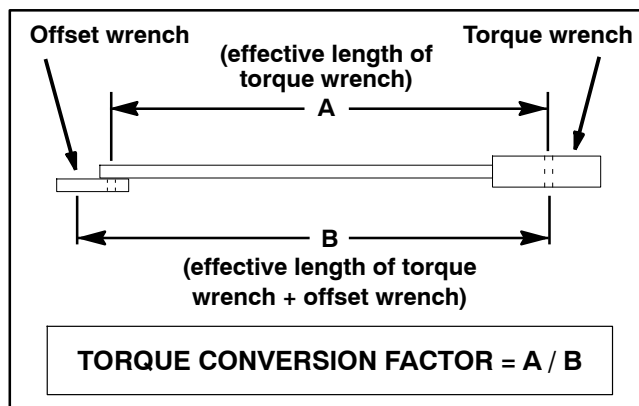

Figure 4

## Standard Torque for Dry, Zinc Plated, and Steel Fasteners (Inch Series)

Thread Size	Grade 1, 5, & 8 with Thin Height Nuts	SAE Grade 1 Bolts, Screws, Studs, & Sems with Regular Height Nuts (SAE J995 Grade 2 or Stronger Nuts)		SAE Grade 5 Bolts, Screws, Studs, & Sems with Regular Height Nuts (SAE J995 Grade 2 or Stronger Nuts)		SAE Grade 8 Bolts, Screws, Studs, & Sems with Regular Height Nuts (SAE J995 Grade 5 or Stronger Nuts)	
	in-lb	in-lb	N-cm	in-lb	N-cm	in-lb	N-cm
# 6 - 32 UNC	10 ± 2	13 ± 2	147 ± 23	15 ± 2	170 ± 20	23 ± 2	260 ± 20
# 6 - 40 UNF				17 ± 2	190 ± 20	25 ± 2	280 ± 20
# 8 - 32 UNC	13 ± 2	25 ± 5	282 ± 30	29 ± 3	330 ± 30	41 ± 4	460 ± 45
# 8 - 36 UNF				31 ± 3	350 ± 30	43 ± 4	485 ± 45
# 10 - 24 UNC	18 ± 2	30 ± 5	339 ± 56	42 ± 4	475 ± 45	60 ± 6	675 ± 70
# 10 - 32 UNF				48 ± 4	540 ± 45	68 ± 6	765 ± 70
1/4 - 20 UNC	48 ± 7	53 ± 7	599 ± 79	100 ± 10	1125 ± 100	140 ± 15	1580 ± 170
1/4 - 28 UNF	53 ± 7	65 ± 10	734 ± 113	115 ± 10	1300 ± 100	160 ± 15	1800 ± 170
5/16 - 18 UNC	115 ± 15	105 ± 17	1186 ± 169	200 ± 25	2250 ± 280	300 ± 30	3390 ± 340
5/16 - 24 UNF	138 ± 17	128 ± 17	1446 ± 192	225 ± 25	2540 ± 280	325 ± 30	3670 ± 340
	ft-lb	ft-lb	N-m	ft-lb	N-m	ft-lb	N-m
3/8 - 16 UNC	16 ± 2	16 ± 2	22 ± 3	30 ± 3	41 ± 4	43 ± 4	58 ± 5
3/8 - 24 UNF	17 ± 2	18 ± 2	24 ± 3	35 ± 3	47 ± 4	50 ± 4	68 ± 5
7/16 - 14 UNC	27 ± 3	27 ± 3	37 ± 4	50 ± 5	68 ± 7	70 ± 7	95 ± 9
7/16 - 20 UNF	29 ± 3	29 ± 3	39 ± 4	55 ± 5	75 ± 7	77 ± 7	104 ± 9
1/2 - 13 UNC	30 ± 3	48 ± 7	65 ± 9	75 ± 8	102 ± 11	105 ± 10	142 ± 14
1/2 - 20 UNF	32 ± 3	53 ± 7	72 ± 9	85 ± 8	115 ± 11	120 ± 10	163 ± 14
5/8 - 11 UNC	65 ± 10	88 ± 12	119 ± 16	150 ± 15	203 ± 20	210 ± 20	285 ± 27
5/8 - 18 UNF	75 ± 10	95 ± 15	129 ± 20	170 ± 15	230 ± 20	240 ± 20	325 ± 27
3/4 - 10 UNC	93 ± 12	140 ± 20	190 ± 27	265 ± 25	359 ± 34	375 ± 35	508 ± 47
3/4 - 16 UNF	115 ± 15	165 ± 25	224 ± 34	300 ± 25	407 ± 34	420 ± 35	569 ± 47
7/8 - 9 UNC	140 ± 20	225 ± 25	305 ± 34	430 ± 45	583 ± 61	600 ± 60	813 ± 81
7/8 - 14 UNF	155 ± 25	260 ± 30	353 ± 41	475 ± 45	644 ± 61	660 ± 60	895 ± 81

**Note:** Reduce torque values listed in the table above by 25% for lubricated fasteners. Lubricated fasteners are defined as threads coated with a lubricant such as oil, graphite, or thread sealant such as Loctite.

**Note:** Torque values may have to be reduced when installing fasteners into threaded aluminum or brass. The specific torque value should be determined based

on the fastener size, the aluminum or base material strength, length of thread engagement, etc.

**Note:** The nominal torque values listed above for Grade 5 and 8 fasteners are based on 75% of the minimum proof load specified in SAE J429. The tolerance is approximately ± 10% of the nominal torque value. Thin height nuts include jam nuts.

## Standard Torque for Dry, Zinc Plated, and Steel Fasteners (Metric Fasteners)

Thread Size	Class 8.8 Bolts, Screws, and Studs with Regular Height Nuts (Class 8 or Stronger Nuts)		Class 10.9 Bolts, Screws, and Studs with Regular Height Nuts (Class 10 or Stronger Nuts)	
M5 X 0.8	57 ± 5 in-lb	640 ± 60 N-cm	78 ± 7 in-lb	885 ± 80 N-cm
M6 X 1.0	96 ± 9 in-lb	1018 ± 100 N-cm	133 ± 13 in-lb	1500 ± 150 N-cm
M8 X 1.25	19 ± 2 ft-lb	26 ± 3 N-m	27 ± 2 ft-lb	36 ± 3 N-m
M10 X 1.5	38 ± 4 ft-lb	52 ± 5 N-m	53 ± 5 ft-lb	72 ± 7 N-m
M12 X 1.75	66 ± 7 ft-lb	90 ± 10 N-m	92 ± 9 ft-lb	125 ± 12 N-m
M16 X 2.0	166 ± 15 ft-lb	225 ± 20 N-m	229 ± 22 ft-lb	310 ± 30 N-m
M20 X 2.5	325 ± 33 ft-lb	440 ± 45 N-m	450 ± 37 ft-lb	610 ± 50 N-m

Product Records and Maintenance

**Note:** Reduce torque values listed in the table above by 25% for lubricated fasteners. Lubricated fasteners are defined as threads coated with a lubricant such as oil, graphite, or thread sealant such as Loctite.

**Note:** Torque values may have to be reduced when installing fasteners into threaded aluminum or brass. The specific torque value should be determined based

on the fastener size, the aluminum or base material strength, length of thread engagement, etc.

**Note:** The nominal torque values listed above are based on 75% of the minimum proof load specified in SAE J1199. The tolerance is approximately ± 10% of the nominal torque value.

## Other Torque Specifications

### SAE Grade 8 Steel Set Screws

Thread Size	Recommended Torque	
	Square Head	Hex Socket
1/4 - 20 UNC	140 ± 20 in-lb	73 ± 12 in-lb
5/16 - 18 UNC	215 ± 35 in-lb	145 ± 20 in-lb
3/8 - 16 UNC	35 ± 10 ft-lb	18 ± 3 ft-lb
1/2 - 13 UNC	75 ± 15 ft-lb	50 ± 10 ft-lb

### Wheel Bolts and Lug Nuts

Thread Size	Recommended Torque*	
7/16 - 20 UNF Grade 5	65 ± 10 ft-lb	88 ± 14 N-m
1/2 - 20 UNF Grade 5	80 ± 10 ft-lb	108 ± 14 N-m
M12 X 1.25 Class 8.8	80 ± 10 ft-lb	108 ± 14 N-m
M12 X 1.5 Class 8.8	80 ± 10 ft-lb	108 ± 14 N-m

\* For steel wheels and non-lubricated fasteners.

### Thread Cutting Screws (Zinc Plated Steel)

Type 1, Type 23, or Type F	
Thread Size	Baseline Torque*
No. 6 - 32 UNC	20 ± 5 in-lb
No. 8 - 32 UNC	30 ± 5 in-lb
No. 10 - 24 UNC	38 ± 7 in-lb
1/4 - 20 UNC	85 ± 15 in-lb
5/16 - 18 UNC	110 ± 20 in-lb
3/8 - 16 UNC	200 ± 100 in-lb

### Thread Cutting Screws (Zinc Plated Steel)

Thread Size	Threads per Inch		Baseline Torque**
	Type A	Type B	
No. 6	18	20	20 ± 5 in-lb
No. 8	15	18	30 ± 5 in-lb
No. 10	12	16	38 ± 7 in-lb
No. 12	11	14	85 ± 15 in-lb

\*\* Hole size, material strength, material thickness & finish must be considered when determining specific torque values. All torque values are based on non-lubricated fasteners.

## Conversion Factors

$$\text{in-lb} \times 11.2985 = \text{N-cm}$$

$$\text{ft-lb} \times 1.3558 = \text{N-m}$$

$$\text{N-cm} \times 0.08851 = \text{in-lb}$$

$$\text{N-m} \times 0.7376 = \text{ft-lb}$$



# Lubrication

## Traction Unit

	<b>CAUTION</b>
<b>Before servicing or making adjustments to the machine, stop engine, lower cutting units, set parking brake, and remove key from the ignition switch.</b>	

The traction unit has grease fittings that must be lubricated regularly with No. 2 General Purpose Lithium Base Grease. If machine is operated under normal conditions, lubricate bearings and bushings after every 50 hours of operation. Bearings and bushings must be lubricated daily when operating conditions are extremely dusty and dirty. Dusty and dirty operating conditions could cause dirt to get into the bearings and bushings, resulting in accelerated wear. Lubricate bearings and bushings immediately after every washing, regardless of the interval listed.

The traction unit bearings and bushings that must be lubricated are: Rear cutting unit pivot (Fig. NO TAG), Front cutting unit pivot (Fig. 2), Sidewinder cylinder ends (qty. 2) (Fig. 3), Steering pivot (Fig. 4), Rear lift arm pivot and lift cylinder (qty. 2) (Fig. 5), Left front lift arm pivot and lift cylinder (qty. 2) (Fig. 6), Right front lift arm pivot and lift cylinder (qty. 2) (Fig. 7), Neutral adjust mechanism (Fig. 8), Mow/Transport slide (Fig. 9), Belt tension pivot (Fig. 10), and Steering cylinder (Fig. 11).

**Note:** If desired, an additional grease fitting may be installed in other end of steering cylinder. Tire must be removed, plug removed, fitting installed, greased, fitting removed and plug reinstalled (Fig. 12).

**IMPORTANT: Do not lubricate Sidewinder cross tube: bearing blocks are self lubricated.**

**IMPORTANT: Lubricate bearings and bushings immediately after washing. This helps to purge water out of bearings and increases bearing life.**

1. Wipe each grease fitting with a clean rag.

**IMPORTANT: Do not apply too much pressure or grease seals will be permanently damaged.**

2. Apply grease until pressure is felt against handle.
3. Wipe excess grease away.

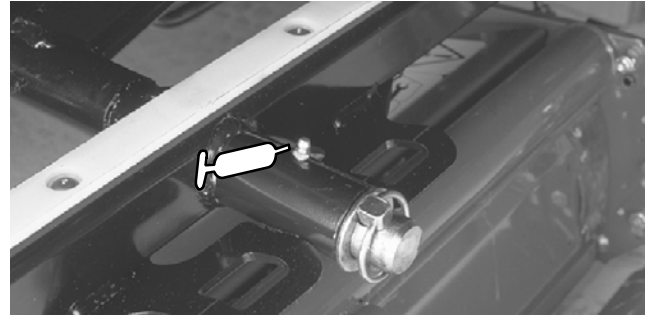

Figure 1

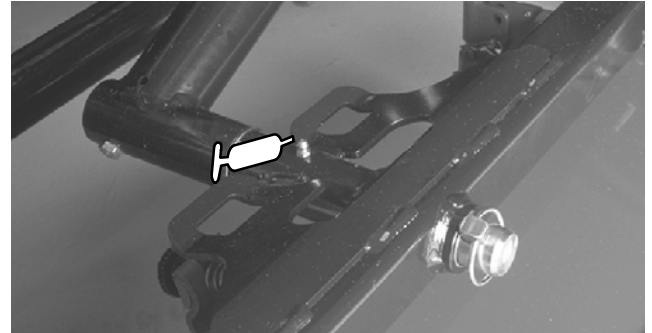

Figure 2

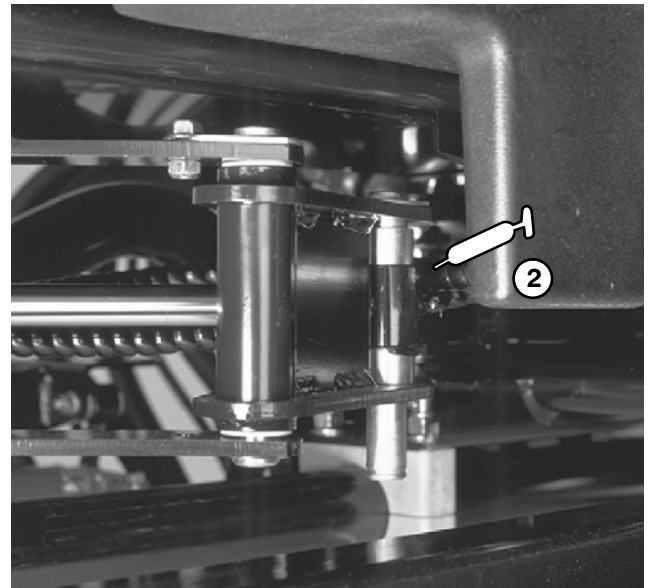

Figure 3

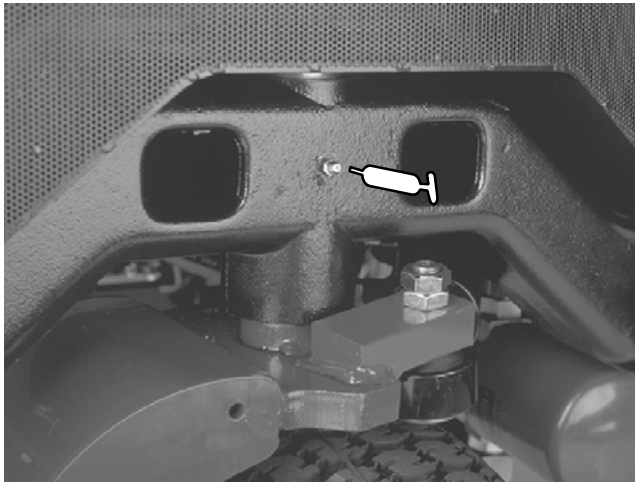

Figure 4

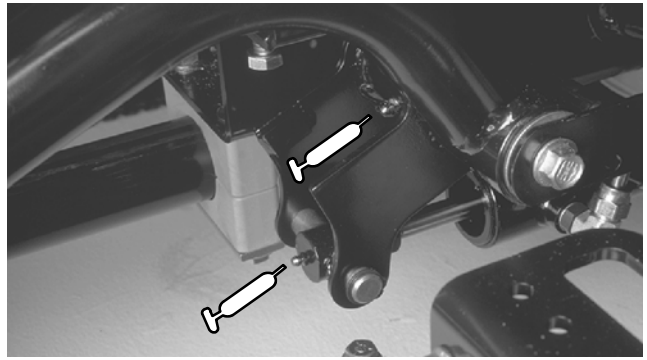

Figure 7

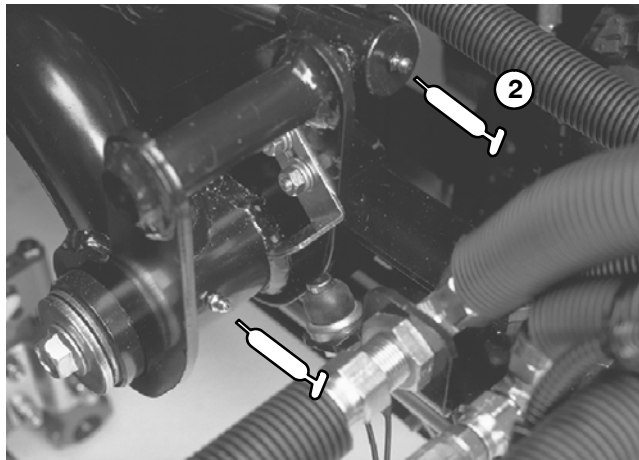

Figure 5

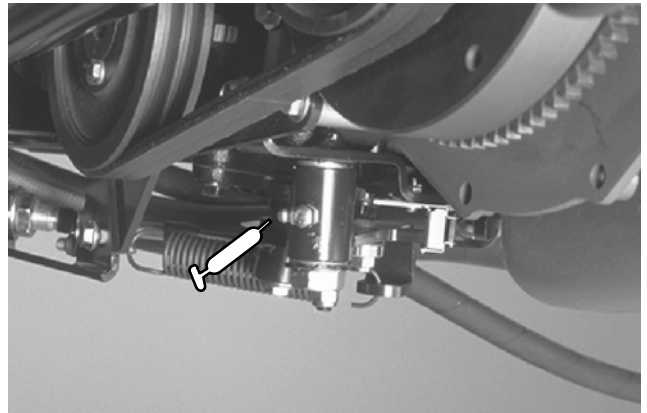

Figure 8

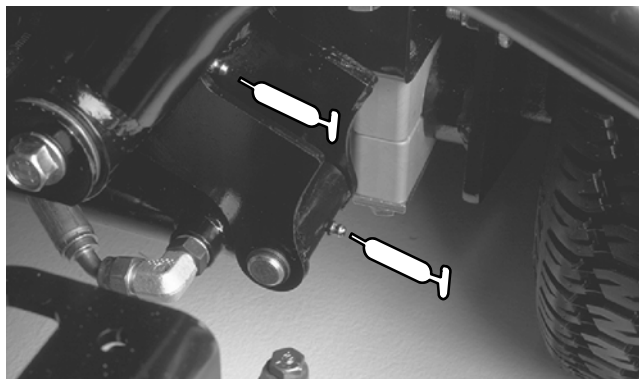

Figure 6

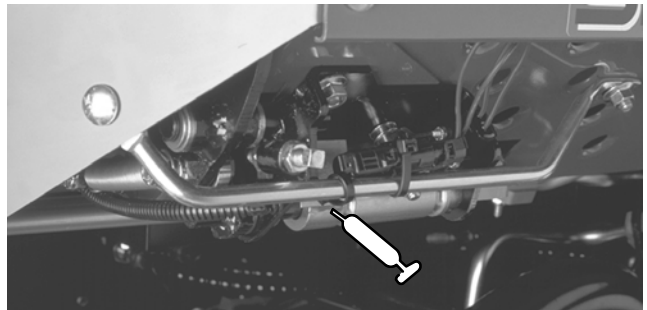

Figure 9

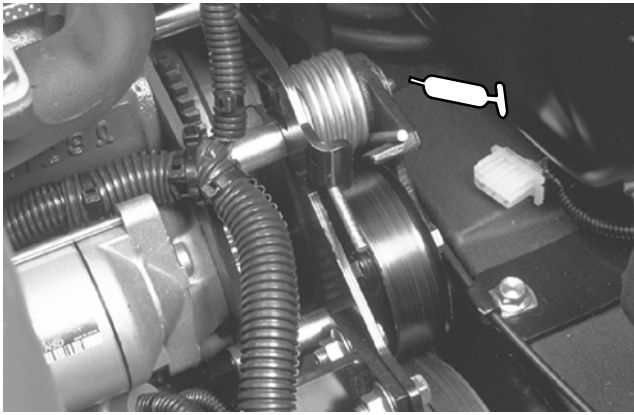

Figure 10

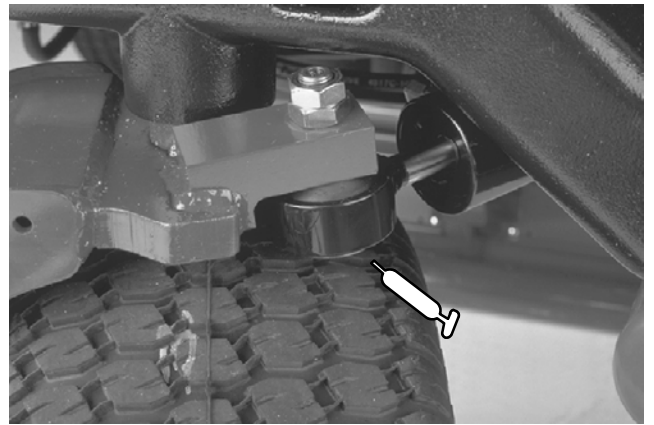

Figure 12 (See note)



Figure 11

## Cutting Units

Each cutting unit has two grease fittings per blade spindle. Either fitting can be used for greasing, which ever is more accessible. Under normal conditions, lubricate spindle bearings with No. 2 General Purpose Lithium Base Grease or Molybdenum base grease, after every 50 hours of operation.

**IMPORTANT: Lubricate cutting units immediately after washing. This helps to purge water out of bearings and increases bearing life.**

1. Wipe grease fitting with a clean rag.

**IMPORTANT: Do not apply too much pressure or grease seals will be permanently damaged.**

2. Apply grease until a small amount appears at bottom of spindle housing (under deck).
3. Wipe excess grease away.

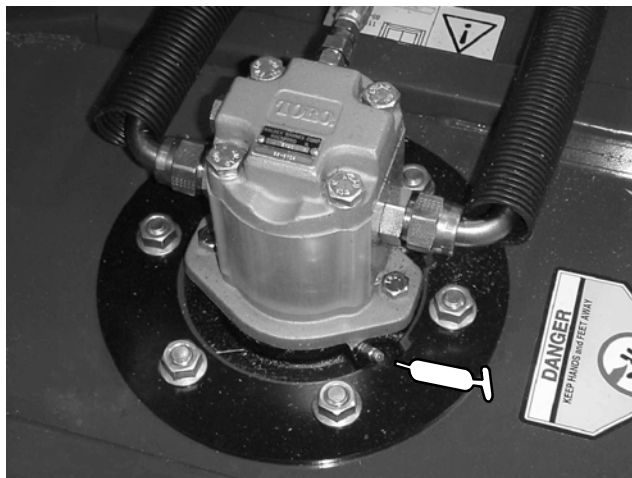

Figure 13

# Preparation for Seasonal Storage

## Traction Unit

1. Clean traction unit, cutting units, and the engine thoroughly.
2. Check tire pressure. Inflate all tires to 14 to 18 psi (0.97 to 1.24 Bar).
3. Check all fasteners for looseness; tighten as necessary.
4. Lubricate all grease fittings and pivot points (see Lubrication).
5. Cover entire length of the Sidewinder cross tube with a light oil to prevent rust. After storage, wipe off all oil.
6. Lightly sand and use touch-up paint on painted areas that are scratched, chipped, or rusted. Repair any dents in the metal body.
7. Service battery and cables as follows:
  - A. Remove battery terminals from the battery posts (see Battery Service in Chapter 5 - Electrical System).
  - B. Clean battery, terminals, and posts with a wire brush and baking soda solution.
  - C. Coat cable terminals and battery posts with Grafo 112X skin-over grease (Toro Part No. 505-47) or petroleum jelly to prevent corrosion.
  - D. Every 30 days, check battery electrolyte levels and fill battery as necessary (see Battery Care in Chapter 5 - Electrical System).
  - E. Every 60 days, recharge battery slowly for 24 hours to prevent sulfate from forming on the battery plates (see manufacturer's instructions for battery charger).

## Traction Unit Engine

1. Drain engine oil from the oil pan and replace the drain plug.
2. Remove and discard oil filter. Install new oil filter.
3. Refill oil pan with approximately 4.0 quarts (3.8 l) of SAE10W-30 motor oil.
4. Start engine and run at idle speed for approximately two minutes.
5. Stop engine.
6. Drain all fuel thoroughly from the fuel tank, fuel lines, and water/fuel separator (see Water/Fuel Separator and Fuel System in Chapter 3 - Kubota Diesel Engine).
7. Flush the fuel tank with fresh, clean diesel fuel (see Fuel System in Chapter 3 - Kubota Diesel Engine).
8. Re-secure all fuel system fittings.
9. Clean and service the air cleaner assembly (see Service Air Filter, Dust Cup, and Burp Valve in Chapter 3 - Kubota Diesel Engine).
10. Seal air cleaner inlet and the exhaust outlet with weatherproof tape.
11. Check anti-freeze protection and add as needed for expected minimum temperature in your area (see Check Cooling System in Chapter 3 - Kubota Diesel Engine).

This page is intentionally blank.



# Kubota Diesel Engine

## Table of Contents

INTRODUCTION .....	2
Operator's Manual .....	2
Kubota Workshop Manual .....	2
SPECIFICATIONS .....	3
ADJUSTMENTS .....	4
Adjust Throttle Cable .....	4
SERVICE AND REPAIRS .....	5
Replace Traction Belt .....	5
Bleed Fuel System .....	6
Bleed Air from Fuel Injectors .....	7
Muffler and Air Cleaner .....	8
Fuel System .....	10
Radiator (Serial Number Below 313999999) ...	12
Radiator and Oil Cooler Assembly (Serial Number Above 314000000) .....	14
Engine .....	16
Removal .....	16
Installation .....	18
KUBOTA WORKSHOP MANUAL, DIESEL ENGINE, 05 SERIES	

Kubota  
Diesel Engine

# Introduction

This Chapter gives information about specifications, maintenance, troubleshooting, testing, and repair of the diesel engine used in the Groundsmaster 3500- D.

Most repairs and adjustments require tools which are commonly available in many service shops. Special tools are described in the Kubota Workshop Manual, Diesel Engine, 05 Series. The use of some specialized test equipment is explained. However, the cost of the

test equipment and the specialized nature of some repairs may dictate that the work be done at an engine repair facility.

Service and repair parts for Kubota engines are supplied through your Authorized Toro Distributor. If no parts list is available, be prepared to provide your distributor with the Toro model and serial number.

---

## Operator's Manual

The Traction Unit Operator's Manual provides information regarding the operation, general maintenance and maintenance intervals for the Kubota diesel engine that powers your Groundsmaster 3500- D. Refer to this publication for additional information when servicing the machine.

---

## Kubota Workshop Manual

The engine that powers your Groundsmaster machine is a Kubota model D1105. The Kubota Workshop Manual is available for these engines. Make sure that the correct engine manual is used when servicing the engine on your Groundsmaster 3500- D.



# Specifications

Item	Description
Make / Designation	Kubota D1105, 4- Cycle, 3 Cylinder, Liquid Cooled, Diesel Engine
Bore mm (in.)	78.0 (3.07)
Stroke mm (in.)	78.4 (3.09)
Total Displacement cc (cu. in.)	1123 (68.53)
Firing Order	1-2-3
Combustion Chamber	Spherical Type
Fuel	No. 2 Diesel Fuel (ASTM D975)
Fuel Capacity liters (gallons)	41.7 (11)
Fuel Injection Pump	Bosch MD Type Mini Pump
Governor	Centrifugal Mechanical
Low Idle (no load)	1400 ± 50 RPM
High Idle (no load)	3050 ± 50 RPM
Direction of Rotation	Counterclockwise (Viewed from Flywheel)
Injection Nozzles	Mini Nozzle (DNOPD)
Engine Oil	See Traction Unit Operator's Manual for viscosity and API classification recommendations
Oil Pump	Gear Driven Trochoid Type
Crankcase Oil Capacity liters (U.S. qt.)	3.8 (4.0) with Filter
Starter	12 VDC, 1.4 KW
Alternator/Regulator	12 VDC, 40 AMP
Dry Weight kilograms (U.S. lbs)	98.0 (215.0)
Coolant Capacity liters (U.S. qt.)	5.7 (6.0) with 0.9 (1.0) Reservoir

**Kubota  
Diesel Engine**

# Adjustments

## Adjust Throttle Cable

1. Park machine on a level surface, lower cutting units, stop engine, engage parking brake, and remove key from the ignition switch. Unlatch and raise hood.
  2. Position throttle control lever all the way to the SLOW position so it stops against the control panel slot (Fig. 5).
  3. Loosen cap screw securing the throttle cable to the swivel enough to loosen the cable (Fig. 6).
  4. Hold speed control lever on the injection pump against the low idle stop. Tighten cable to the swivel with cap screw (Fig. 6).
  5. Loosen screws securing throttle control lever to the control panel (Fig. 5).
  6. Push throttle control lever all the way to the FAST position. Slide stop plate until it contacts throttle control lever, and tighten screws securing throttle control to control panel (Fig. 5).
- Note:** Attach spring scale where the throttle cable is attached to the control lever (Fig. 7).
7. If throttle control lever does not stay in position during operation, torque lock nut and cap screw used to tighten the friction disc from 40 to 55 in- lb (4.5 to 6.2 N- m). The force required to operate the throttle control lever should be 20 lb (89 N). Torque fasteners as necessary (Fig. 7).
  8. Close and secure hood.

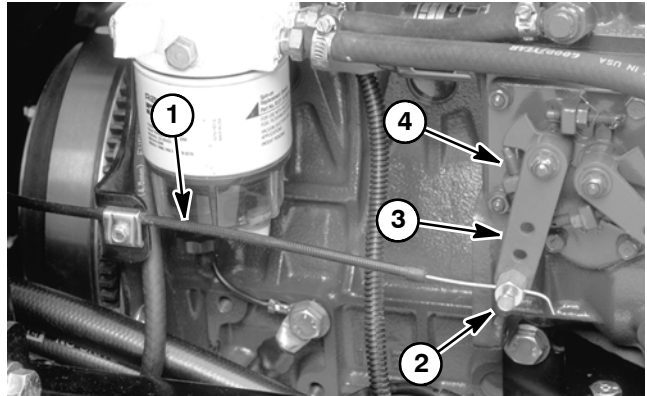

Figure 6

- |                   |                        |
|-------------------|------------------------|
| 1. Throttle cable | 3. Speed control lever |
| 2. Swivel         | 4. Low idle stop       |

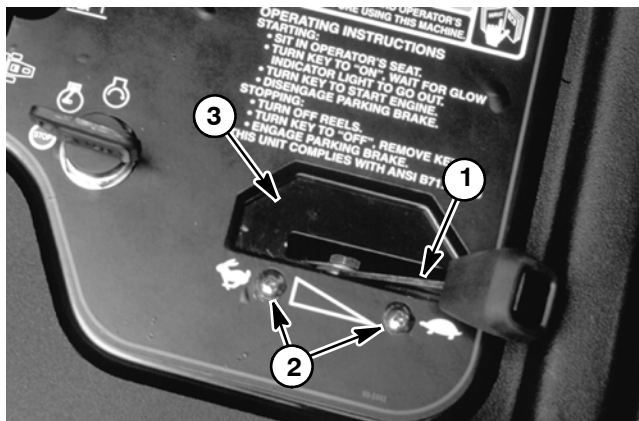

Figure 5

- |                           |               |
|---------------------------|---------------|
| 1. Throttle control lever | 3. Stop plate |
| 2. Screws                 |               |

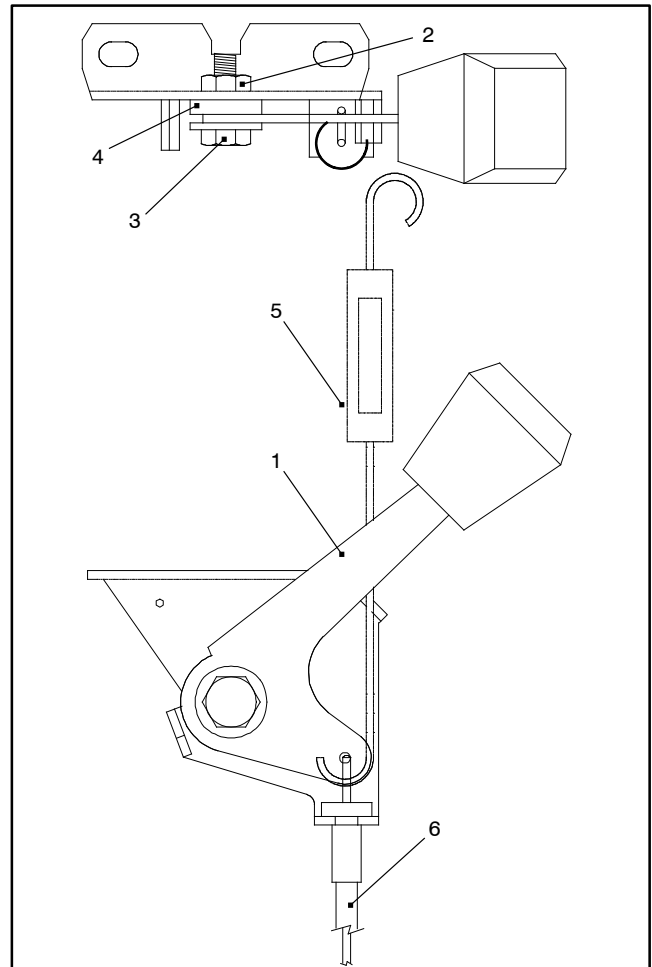

Figure 7

- |                           |                   |
|---------------------------|-------------------|
| 1. Throttle control lever | 4. Friction disc  |
| 2. Lock nut               | 5. Spring scale   |
| 3. Cap screw              | 6. Throttle cable |

# Service and Repairs

## Replace Traction Belt

1. Park machine on a level surface, lower cutting units, stop engine, engage parking brake, and remove key from the ignition switch. Unlatch and raise hood.
2. Insert nut driver or small piece of pipe onto the end of the torsion spring of the idler pulley.

**CAUTION**

**Be careful when removing or applying tension from or to the torsion spring of the idler pulley. The spring is under heavy load and may cause personal injury.**

3. Push down and forward on the spring end to unhook the spring from the pump mounting plate.
4. Remove drive belt from the engine flywheel and hydrostat pulleys.
5. Install replacement drive belt onto the engine flywheel and hydrostat pulleys.
6. Insert nut driver or small piece of pipe onto the end of the torsion spring of the idler pulley.
7. Push down and back on the spring end to get the spring under the pump mounting plate notch. Then release the spring slowly to lock it into place.

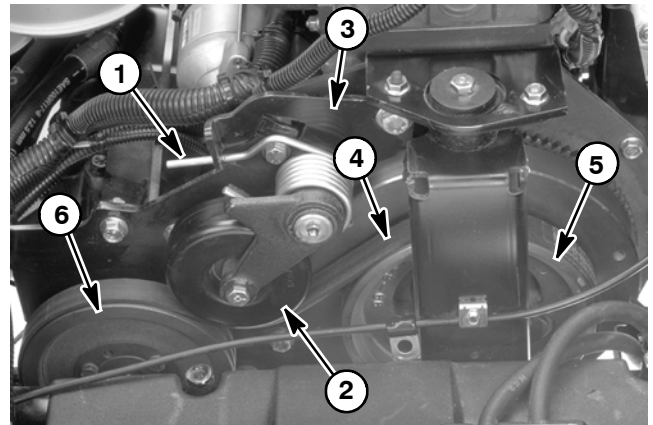

Figure 8

- |                        |                     |
|------------------------|---------------------|
| 1. Torsion spring      | 4. Drive belt       |
| 2. Idler pulley        | 5. Flywheel pulley  |
| 3. Pump mounting plate | 6. Hydrostat pulley |

## Bleed Fuel System

1. Park machine on a level surface, lower cutting units, stop engine, and engage parking brake.
2. Make sure fuel tank is at least half full. Unlatch and raise hood.



**DANGER**

Because diesel fuel is highly flammable, use caution when storing or handling it. Do not smoke while filling the fuel tank. Do not fill fuel tank while engine is running or hot, or when machine is in an enclosed area. Always fill fuel tank outside and wipe up any spilled diesel fuel before starting the engine. Store fuel in a clean, safety-approved container and keep cap in place. Use diesel fuel for the engine only; not for any other purpose.

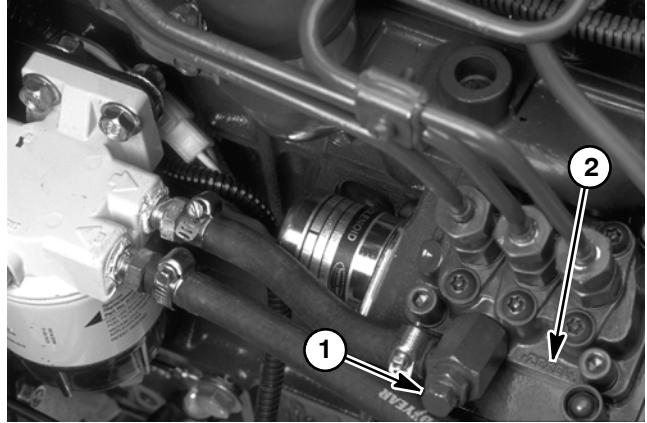

Figure 9

1. Air bleed screw
2. Injection pump

3. Open air bleed screw on the fuel injection pump.

**IMPORTANT:** The engine should normally start after the bleeding procedures are followed. However, if the engine does not start, air may be trapped between injection pump and injectors (see **Bleed Air from Fuel Injectors**).

4. Turn ignition key switch to the ON position. The electric fuel pump will begin operation and force air out around the air bleed screw. Leave key in the ON position until a solid stream of fuel flows out around the air bleed screw. Tighten screw and turn key to OFF.
5. Clean up any spilled fuel.
6. Close and secure hood.

## Bleed Air from Fuel Injectors

**IMPORTANT:** This procedure should be used only if the fuel system has been purged of air through normal priming procedures (see Bleed Fuel System) and engine will not start.

1. Park machine on a level surface, lower cutting units, stop engine, and engage parking brake. Unlatch and raise hood.



### DANGER

Because diesel fuel is highly flammable, use caution when storing or handling it. Do not smoke while filling the fuel tank. Do not fill fuel tank while engine is running, hot, or when machine is in an enclosed area. Always fill fuel tank outside and wipe up any spilled diesel fuel before starting the engine. Store fuel in a clean, safety-approved container and keep cap in place. Use diesel fuel for the engine only; not for any other purpose.

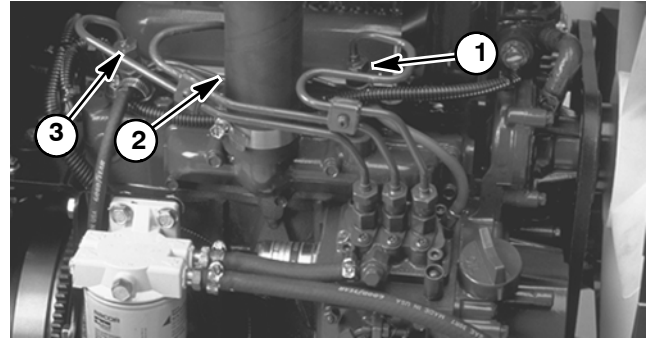

Figure 10

1. #1 injector nozzle
2. #2 nozzle (behind hose)
3. #3 injector nozzle

2. Loosen pipe connection to the No. 1 injector nozzle and holder assembly.
3. Move throttle to FAST position.
4. Turn ignition switch to START and watch for fuel flow around connector. Turn key to OFF when solid flow is observed. Tighten pipe connector securely to the injector nozzle.
5. Repeat steps on the remaining injector nozzles. Clean up any spilled fuel.
6. Close and secure hood.

# Muffler and Air Cleaner

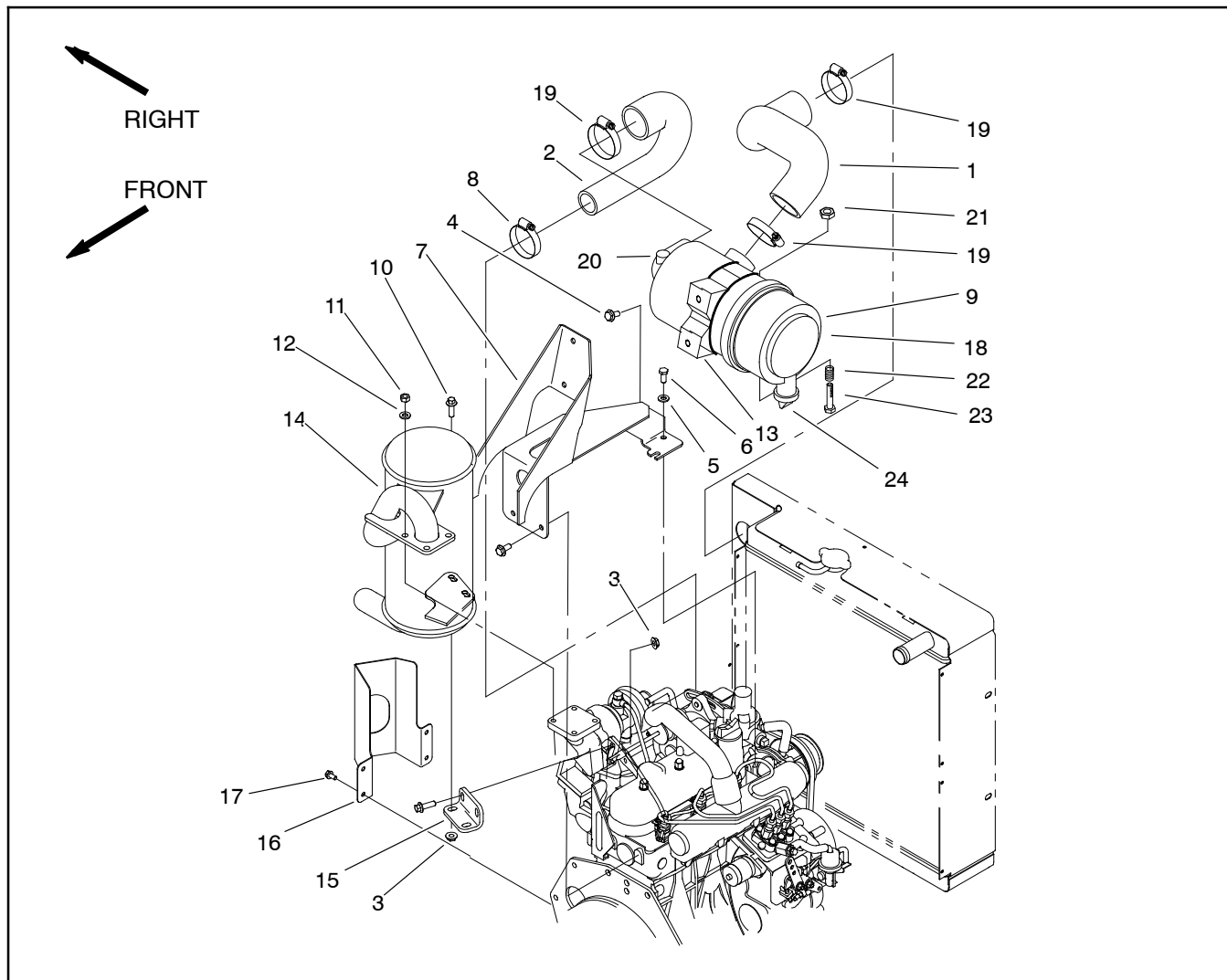

Figure 11

- |                           |                                 |                        |
|---------------------------|---------------------------------|------------------------|
| 1. Air inlet hose (upper) | 9. Air cleaner body             | 17. Cap screw          |
| 2. Air inlet hose (lower) | 10. Flange head screw           | 18. Filter cover       |
| 3. Flange nut             | 11. Hex nut                     | 19. Hose clamp         |
| 4. Flange head screw      | 12. Lock washer                 | 20. Plug               |
| 5. Flat washer            | 13. Mounting band assembly      | 21. Lock nut           |
| 6. Cap screw              | 14. Muffler                     | 22. Compression spring |
| 7. Air filter mount       | 15. Muffler bracket             | 23. Bolt               |
| 8. Hose clamp             | 16. Exhaust guard (if equipped) | 24. Evacuator valve    |

## Muffler Removal (Fig. 11)



### CAUTION

The muffler and exhaust pipe may be hot. To avoid possible burns, allow the engine and exhaust system to cool before working on the muffler.

1. Park machine on a level surface, lower cutting units, stop engine, engage parking brake, and remove key from the ignition switch.
2. Open engine hood to gain access to engine.
3. Remove exhaust guard from frame (if equipped).
4. Remove both flange head nuts and screws securing the muffler plate to the muffler bracket (Fig. 12).
5. Remove four hex nuts and lock washers from the exhaust manifold studs. Separate muffler flange from the exhaust manifold. Remove muffler from the machine.
6. Remove exhaust gasket. Replace gasket if damaged or torn.

## Muffler Installation (Fig. 11)

**Note:** Make sure muffler flange and exhaust manifold sealing surfaces are free of debris or damage that may prevent a tight seal.

1. Place exhaust gasket on the exhaust manifold.

**IMPORTANT: Finger tighten all fasteners before securing the muffler plate to the muffler bracket so there is no preload on the exhaust manifold.**

2. Position muffler flange to the exhaust manifold with four lock washers and hex nuts.
3. Position muffler plate to the muffler bracket with both flange head screws and nuts (Fig. 12).
4. Tighten muffler flange hex nuts and then muffler plate screws and nuts.
5. Install exhaust guard to frame (if equipped).
6. Close and latch engine hood.

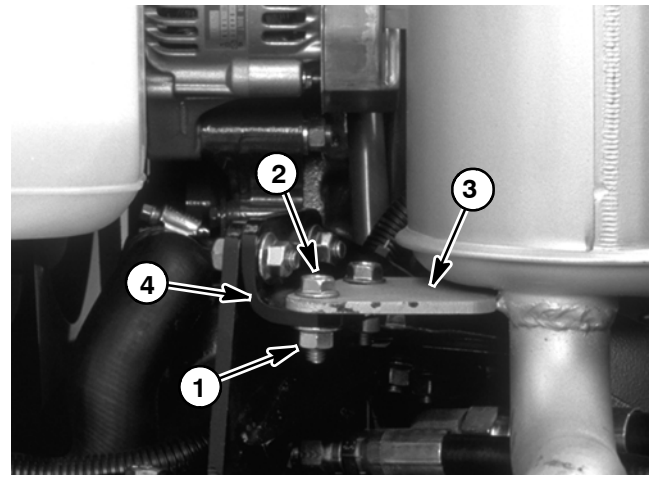

Figure 12

- |                      |                    |
|----------------------|--------------------|
| 1. Flange head nut   | 3. Muffler plate   |
| 2. Flange head screw | 4. Muffler bracket |

## Air Cleaner Removal (Fig. 11)

1. Park machine on a level surface, lower cutting units, stop engine, engage parking brake, and remove key from the ignition switch. Unlatch and raise hood.
2. Remove air cleaner components as needed using Figure 11 as a guide.

## Air Cleaner Installation (Fig. 11)

**IMPORTANT: Any leaks in the air cleaner system will cause serious engine damage. Make sure that all air cleaner components are in good condition and are properly secured during assembly.**

1. Assemble air cleaner system using Figure 11 as a guide.
  - A. When installing air cleaner, orientate the evacuator valve on the air cleaner cover so that the valve is pointing in a downward position.
  - B. Make sure that air cleaner hoses do not contact the engine or exhaust system after assembly. To ensure clearance, move and/or rotate air cleaner body in air cleaner strap if necessary.
2. After all air cleaner components have been installed, lower and secure hood.

# Fuel System

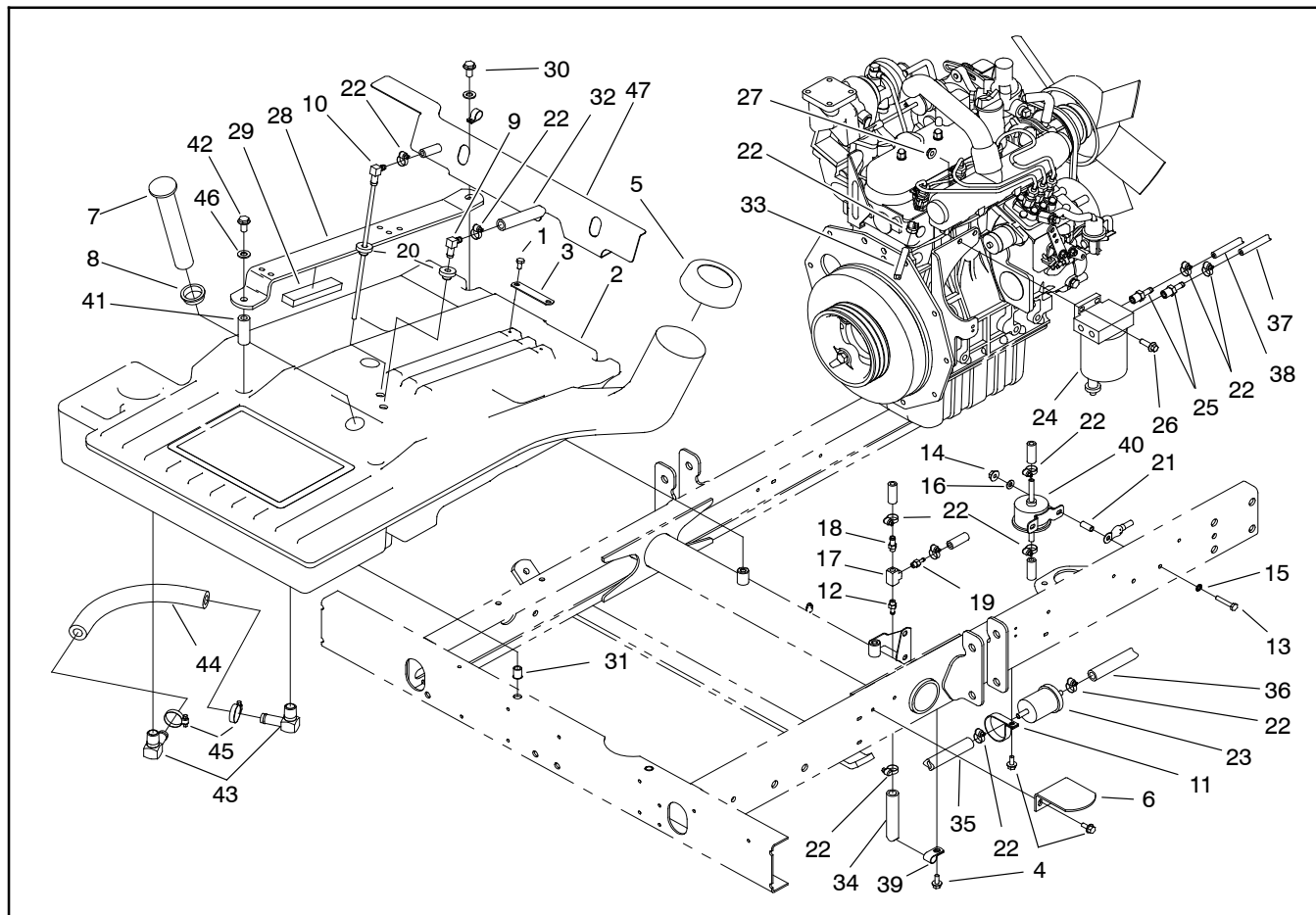

Figure 13

- |                      |                                  |                 |
|----------------------|----------------------------------|-----------------|
| 1. Cap screw         | 17. Tee fitting                  | 33. Fuel hose   |
| 2. Fuel tank         | 18. Barb fitting                 | 34. Fuel hose   |
| 3. Fuel hose strap   | 19. Barb fitting                 | 35. Fuel hose   |
| 4. Cap screw         | 20. Bushing                      | 36. Fuel hose   |
| 5. Fuel cap          | 21. Spacer                       | 37. Fuel hose   |
| 6. Tank support      | 22. Hose clamp                   | 38. Fuel hose   |
| 7. Fuel gauge        | 23. Fuel prefilter (if equipped) | 39. R-clamp     |
| 8. Grommet           | 24. Fuel/water separator         | 40. Fuel pump   |
| 9. Connector fitting | 25. Fuel fitting                 | 41. Spacer      |
| 10. Stand pipe       | 26. Flange head screw            | 42. Cap screw   |
| 11. R-clamp          | 27. Flange nut                   | 43. Hose stem   |
| 12. Barb fitting     | 28. Seat support strap           | 44. Fuel hose   |
| 13. Cap screw        | 29. Foam                         | 45. Hose clamp  |
| 14. Flange hex nut   | 30. Hex flange head screw        | 46. Flat washer |
| 15. Lock washer      | 31. Insert nut                   | 47. Heat shield |
| 16. Flat washer      | 32. Fuel hose                    |                 |





## DANGER

**Because diesel fuel is highly flammable, use caution when storing or handling it. Do not smoke while filling the fuel tank. Do not fill fuel tank while engine is running or hot, or when machine is in an enclosed area. Always fill fuel tank outside and wipe up any spilled diesel fuel before starting the engine. Store fuel in a clean, safety-approved container and keep cap in place. Use diesel fuel for the engine only; not for any other purpose.**

### Check Fuel Lines and Connections

Check fuel lines and connections at intervals recommended in your Operator's Manual.

1. Park machine on a level surface, lower cutting units, stop engine, engage parking brake, and remove key from the ignition switch. Unlatch and raise hood.
2. Check fuel lines for deterioration, damage, leaks, or loose connections. Replace hoses, clamps, and connections as necessary.

### Fuel Tank Removal (Fig. 13)

1. Park machine on a level surface, lower cutting units, stop engine, engage parking brake, and remove key from the ignition switch. Unlatch and raise hood.
2. Remove fuel from the tank into a suitable container. Crossover fuel hose removal may assist to drain tank completely.
3. Remove seat and seat support straps from the frame. Note location of spacers under front of seat support straps. Disconnect seat switch from the electrical harness (Fig. 14).
4. Remove fuel hose strap and both fuel hoses from the fuel tank. Pull tank from the machine (Fig. 14).

### Drain and Clean Fuel Tank

Drain and clean the fuel tank every 2 years. Also, drain and clean the fuel tank if the fuel system becomes contaminated or if the machine is to be stored for an extended period.

1. Remove fuel tank from the machine (see Fuel Tank Removal).
2. Flush fuel tank out with clean diesel fuel. Make sure tank is free of contaminants and debris.
3. Install fuel tank to the machine (see Fuel Tank Installation).

### Fuel Tank Installation (Fig. 13)

1. Position fuel tank to the machine.
2. Connect both fuel hoses to the tank and secure with hose clamps and fuel hose strap.
3. Connect seat switch to the electrical harness. Route seat switch wire under seat support strap. Secure seat support straps and seat to the frame with hex flange head screws.
4. Check for correct seat operation and that seat switch wires and connector are not pinched and do not contact any moving parts.
5. Fill fuel tank.

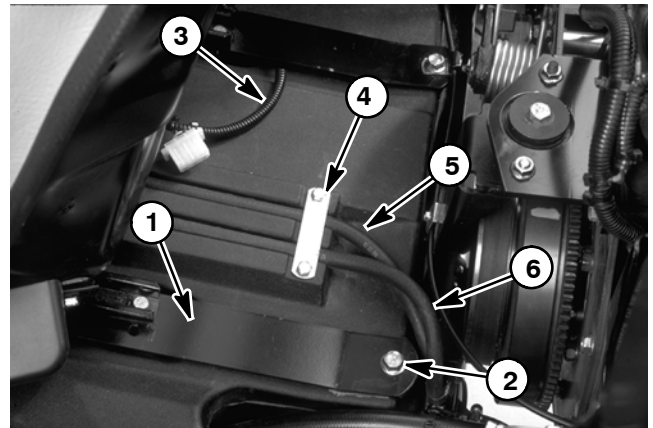

Figure 14

- |                          |                     |
|--------------------------|---------------------|
| 1. Seat support strap    | 4. Fuel hose strap  |
| 2. Hex flange head screw | 5. Fuel supply hose |
| 3. Electrical harness    | 6. Fuel return hose |

## Radiator (Serial Number Below 31399999)

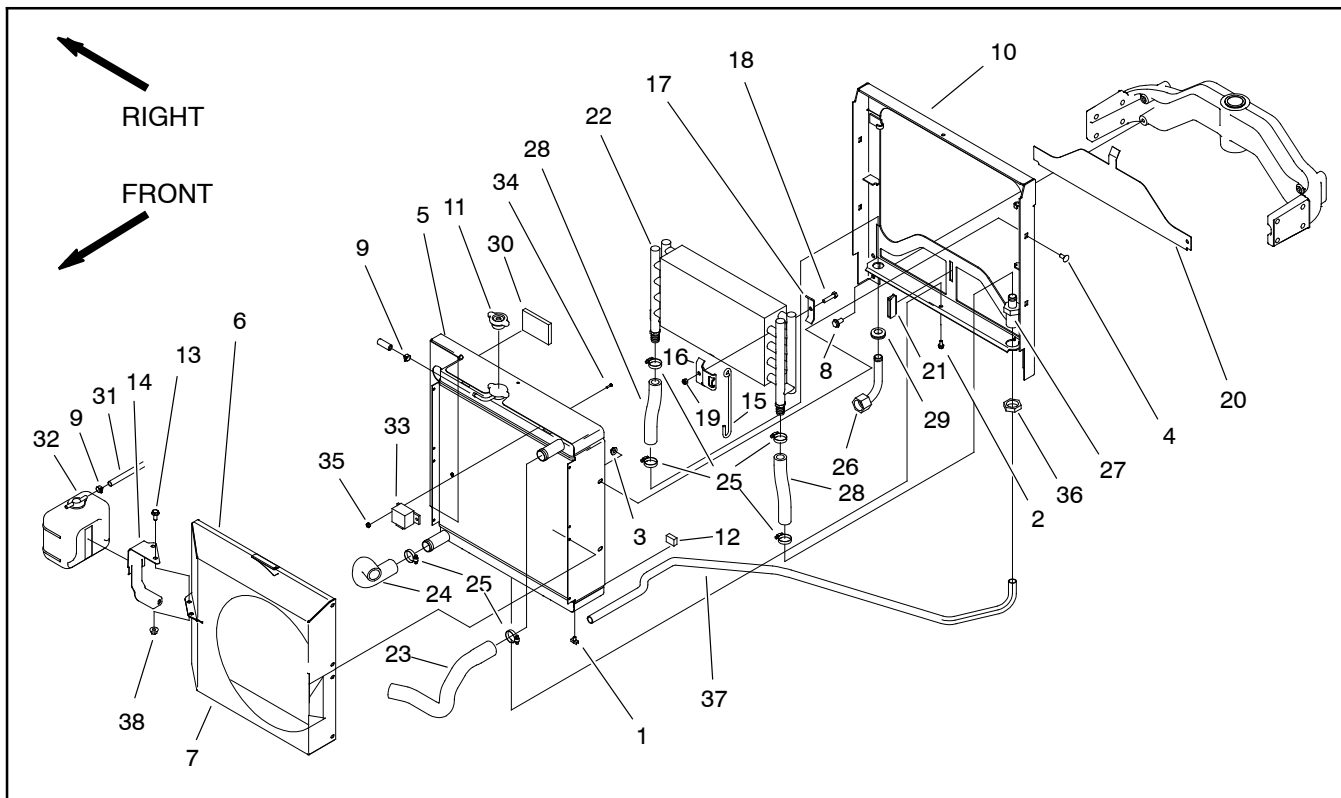

Figure 15

- |                        |                             |                          |
|------------------------|-----------------------------|--------------------------|
| 1. Draincock valve     | 14. Reservoir bracket       | 27. Hydraulic tube       |
| 2. Flange head screw   | 15. Wire form latch         | 28. Oil cooler hose      |
| 3. Flange nut          | 16. Oil cooler bracket      | 29. Grommet              |
| 4. Carriage bolt       | 17. Bracket clamp           | 30. Foam seal            |
| 5. Radiator            | 18. Screw                   | 31. Expansion tank hose  |
| 6. Fan shroud (top)    | 19. Lock nut                | 32. Expansion tank       |
| 7. Fan shroud (bottom) | 20. Radiator shield (lower) | 33. Glow plug relay      |
| 8. Flange head screw   | 21. Magnetic catch          | 34. Thread forming screw |
| 9. Hose clamp          | 22. Oil cooler              | 35. Flange lock nut      |
| 10. Radiator frame     | 23. Radiator hose (upper)   | 36. Bulkhead nut         |
| 11. Radiator cap       | 24. Radiator hose (lower)   | 37. Tube assembly        |
| 12. Radiator foam seal | 25. Hose clamp              | 38. Nut                  |
| 13. Flange head screw  | 26. Hydraulic tube          |                          |

### Removal

1. Park machine on a level surface, lower cutting units, stop engine, engage parking brake, and remove key from the ignition switch.
2. Open and remove engine hood from the machine.



## CAUTION

Do not open radiator cap or drain coolant if the radiator or engine is hot. Pressurized, hot coolant can escape and cause burns. Ethylene-glycol antifreeze is poisonous. Dispose of coolant properly, or store it in a properly labeled container away from children and pets.

3. Place a suitable container under the radiator to collect the coolant. Open draincock valve, and completely drain the radiator.

**IMPORTANT: Follow all local codes and regulations when recycling or disposing engine coolant.**

4. Remove glow plug relay from the radiator assembly. Position relay away from the radiator.
5. Disconnect following hoses from the radiator:
  - A. Upper radiator hose to the water pump.
  - B. Lower radiator hose to the engine block.
  - C. Coolant hose to the expansion tank.
  - D. Air hose to the air cleaner.

6. Remove expansion tank and bracket from the top fan shroud.
7. Remove both fan shrouds from radiator assembly.
8. Remove flange head screws securing the top and bottom of the radiator frame to the radiator. Remove four carriage bolts and lock nuts securing the radiator to the radiator frame.
9. Pull radiator carefully from the radiator frame.
10. Plug any openings to prevent contamination.

### Installation

1. Remove any plugs used during the removal procedures.
2. Position radiator carefully to the radiator frame.
3. Secure radiator assembly to the radiator frame with four carriage bolts and lock nuts. Secure top and bottom of radiator to frame with flange head screws.
4. Secure both fan shrouds to the radiator assembly with flange head screws.
5. Secure expansion tank bracket and tank to the top fan shroud with both flange head screws and flange nuts.
6. Connect following hoses to the radiator:
  - A. Upper radiator hose to the water pump.
  - B. Lower radiator hose to the engine block.
  - C. Coolant hose to the expansion tank.
  - D. Air hose to the air cleaner.

7. Secure glow plug relay to the radiator assembly with both thread forming screws.
8. Make sure draincock valve is closed. Fill radiator with coolant.
9. Install engine hood to the machine. Close and latch hood.

### Clean Radiator and Oil Cooler (Fig. 16)

The radiator and oil cooler should be checked for dirt and debris daily, and hourly if conditions are extremely dusty and dirty.

1. Park machine on a level surface, lower cutting units, stop engine, engage parking brake, and remove key from the ignition switch.



## CAUTION

**If engine has been running, the radiator may be hot and cause burns. Work on radiator only when the engine and radiator are cool.**

2. Unlatch and open engine hood.
3. Clean engine area thoroughly of all dirt and debris.
4. Remove lower radiator shield. Release wire form latch and allow oil cooler to pivot out (Fig. 17).
5. Clean both sides of oil cooler and radiator area thoroughly with water or compressed air.
6. Pivot oil cooler back and latch into position. Install lower shield. Close and latch hood.

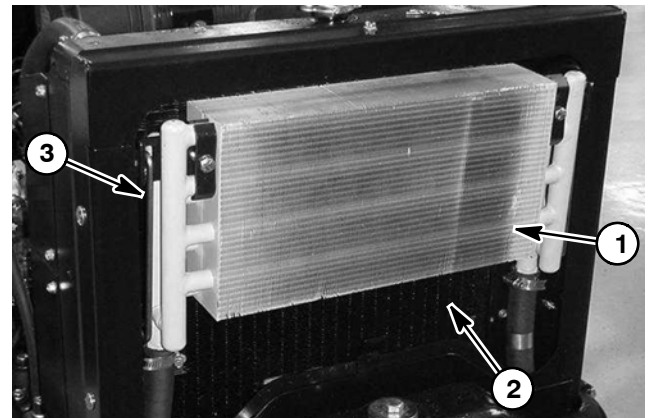

Figure 16

- |               |                    |
|---------------|--------------------|
| 1. Oil cooler | 3. Wire form latch |
| 2. Radiator   |                    |

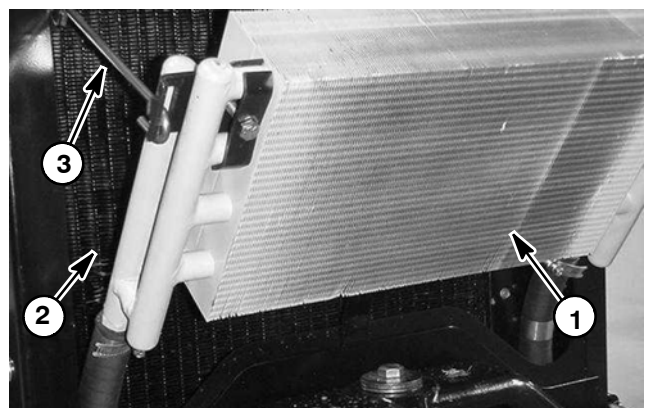

Figure 17

- |                             |                    |
|-----------------------------|--------------------|
| 1. Oil cooler (pivoted out) | 3. Wire form latch |
| 2. Radiator                 |                    |

## Radiator and Oil Cooler Assembly (Serial Number Above 314000000)

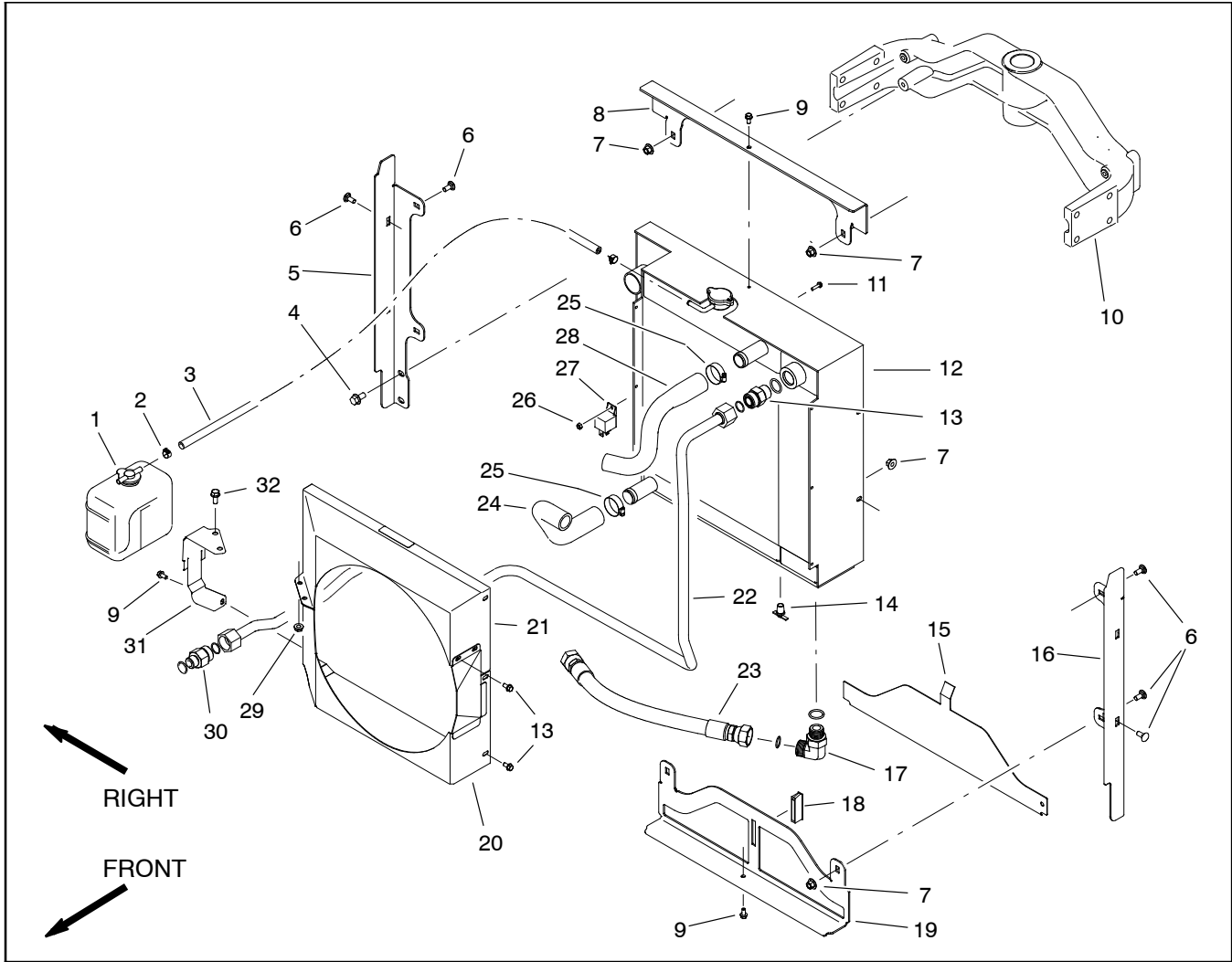

Figure 18

- |                           |                               |                            |
|---------------------------|-------------------------------|----------------------------|
| 1. Expansion tank         | 12. Radiator                  | 23. Hydraulic hose         |
| 2. Hose clamp             | 13. Straight fitting          | 24. Lower radiator hose    |
| 3. Coolant hose           | 14. Draincock                 | 25. Hose clamp             |
| 4. Flange head screw      | 15. Lower radiator shield     | 26. Hex nut                |
| 5. Radiator bracket - RH  | 16. Radiator bracket - LH     | 27. Relay                  |
| 6. Carriage bolt          | 17. Elbow fitting             | 28. Upper radiator hose    |
| 7. Flange nut             | 18. Magnet                    | 29. Flange nut             |
| 8. Radiator bracket - top | 19. Radiator bracket - bottom | 30. Straight fitting       |
| 9. Flange head screw      | 20. Lower fan shroud          | 31. Expansion tank support |
| 10. Frame casting         | 21. Upper fan shroud          | 32. Flange head screw      |
| 11. Cap screw             | 22. Hydraulic tube            |                            |

**NOTE:** On machines with serial number above 314000000, the hydraulic oil cooler is combined with the radiator as shown in Figure 18.

### Removal

1. Park machine on a level surface, lower cutting units, stop engine, engage parking brake, and remove key from the ignition switch.
2. Open and remove engine hood from the machine.



## CAUTION

Do not open radiator cap or drain coolant if the radiator or engine is hot. Pressurized, hot coolant can escape and cause burns. Ethylene-glycol antifreeze is poisonous. Dispose of coolant properly, or store it in a properly labeled container away from children and pets.

3. Place a suitable container under the radiator to collect the coolant. Open draincock valve, and completely drain the radiator.

**IMPORTANT: Follow all local codes and regulations when recycling or disposing engine coolant.**

4. Remove glow plug relay from the radiator assembly. Position relay away from the radiator.

5. Place a suitable container under the hydraulic filter to collect the hydraulic fluid. The container should have a 6 gal. (23 Ltr.) minimum capacity. Disconnect the hydraulic hose below the filter head or remove the hydraulic filter element and drain the hydraulic system (Fig. 19).

6. Disconnect the coolant hoses from the radiator/oil cooler assembly:

- A. Upper radiator hose to the water pump.
- B. Lower radiator hose to the engine block.
- C. Coolant hose to the expansion tank.
- D. Air hose to the air cleaner.

7. Disconnect the hydraulic hoses from the oil cooler section of the radiator/oil cooler assembly:

- A. Hydraulic tube from top of hydraulic fluid cooler.
- B. Hydraulic hose from bottom of hydraulic fluid cooler.

8. Remove expansion tank from the fan shroud.

9. Remove expansion tank bracket and both fan shrouds from radiator assembly.

10. Remove flange head screws securing the top and bottom of the radiator frame to the radiator. Remove four carriage bolts and lock nuts securing the radiator to the radiator frame.

11. Carefully remove radiator from the radiator frame.

12. Plug any openings to prevent contamination.

### Installation

1. Remove all plugs used during the removal procedures.

2. Position radiator carefully to the radiator frame.

3. Secure radiator assembly to the radiator frame with four carriage bolts and lock nuts. Secure top and bottom of radiator to frame with flange head screws.

4. Secure both fan shrouds to the radiator assembly with flange head screws.

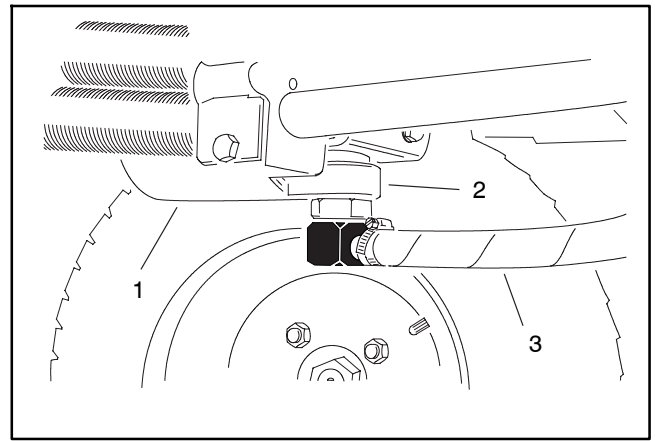

Figure 19

- 1. Hydraulic filter element
- 2. Hydraulic filter head
- 3. Hydraulic hose

5. Secure expansion tank bracket and tank to the top fan shroud with both flange head screws and flange nuts.

6. Connect the following hydraulic hoses to the oil cooler section of the radiator/oil cooler assembly:

- A. Hydraulic tube to top of hydraulic fluid cooler.
- B. Hydraulic hose to bottom of hydraulic fluid cooler.

7. Connect following coolant hoses to the radiator/oil cooler assembly:

- A. Upper radiator hose to the water pump.
- B. Lower radiator hose to the engine block.
- C. Coolant hose to the expansion tank.
- D. Air hose to the air cleaner.

8. Secure glow plug relay to the radiator assembly with both thread forming screws.

9. Make sure draincock valve in radiator is closed. Fill radiator with coolant to the bottom of the filler neck.

10. Install engine hood to the machine. Close and latch hood.

11. Start engine. Check for fluid leaks and proper engine operation.

12. After running engine for a short time, stop engine and make sure hydraulic tank is full. Add correct oil if necessary.

# Engine

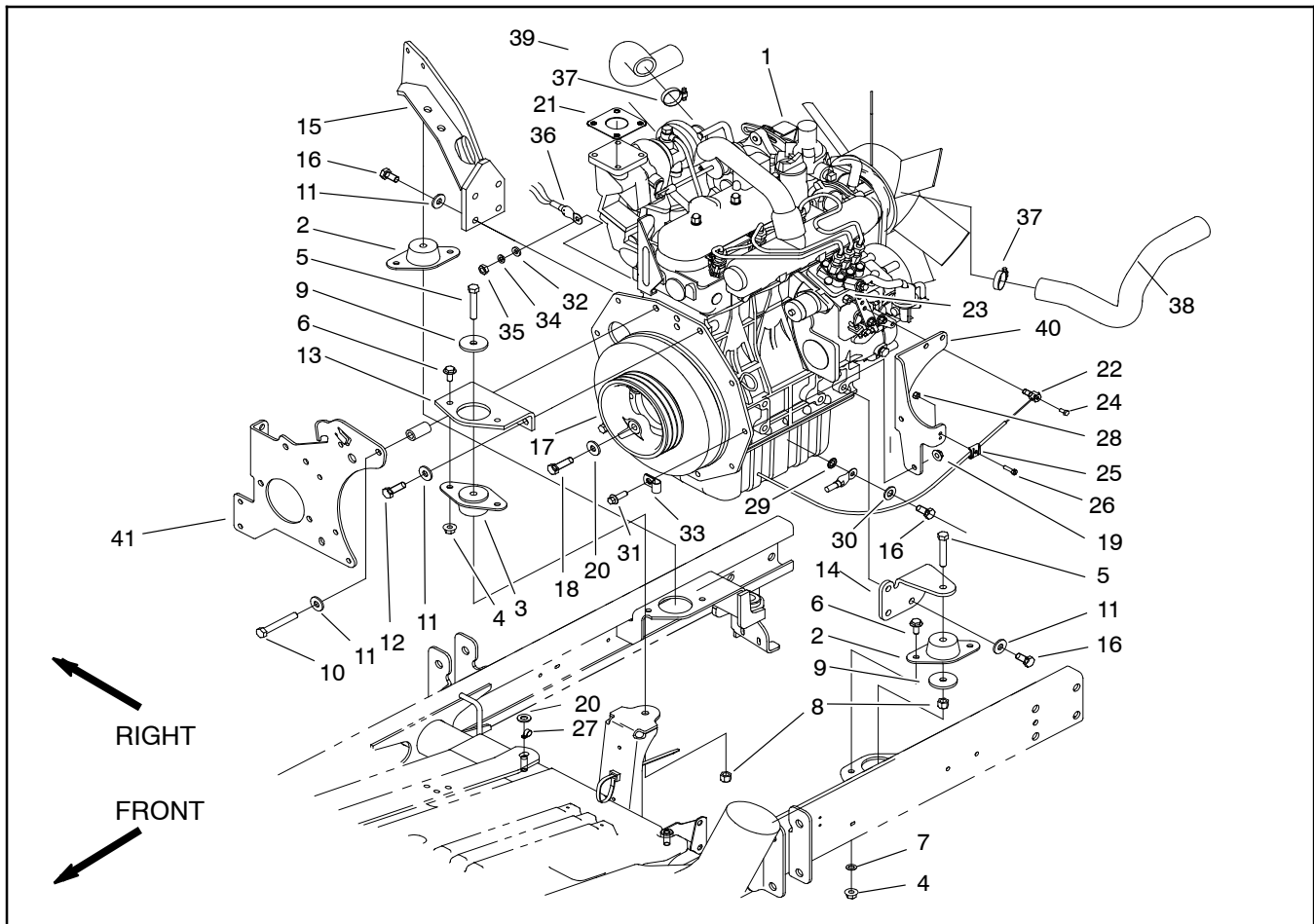

Figure 20

- |                                     |                                  |                              |
|-------------------------------------|----------------------------------|------------------------------|
| 1. Kubota engine                    | 15. Engine mounting bracket (RH) | 29. Lock washer              |
| 2. Engine mount                     | 16. Cap screw                    | 30. Flat washer              |
| 3. Engine mount                     | 17. Pulley                       | 31. Flange head screw        |
| 4. Flange nut                       | 18. Bolt                         | 32. Flat washer              |
| 5. Cap screw                        | 19. Flange nut                   | 33. R-clamp                  |
| 6. Hex flange head screw            | 20. Washer                       | 34. Lock washer              |
| 7. External lock washer             | 21. Exhaust gasket               | 35. Hex nut                  |
| 8. Lock nut                         | 22. Throttle swivel              | 36. Wire harness             |
| 9. Hardened washer                  | 23. Lock nut                     | 37. Hose clamp               |
| 10. Machine screw                   | 24. Slotted hex head screw       | 38. Radiator hose (upper)    |
| 11. Hardened washer                 | 25. Throttle cable clamp         | 39. Radiator hose (lower)    |
| 12. Cap screw                       | 26. Cap screw                    | 40. Throttle support bracket |
| 13. Engine mounting bracket (front) | 27. R-clamp                      | 41. Pump mount plate         |
| 14. Engine mounting bracket (LH)    | 28. Lock nut                     |                              |

## Removal

1. Park machine on a level surface, lower cutting units, stop engine, engage parking brake, and remove key from the ignition switch.

2. Open and remove engine hood from the machine (see Hood Removal in Chapter 6 - Wheels, Brakes, and Chassis). Slide seat all the way forward.

3. Disconnect air hose from the air cleaner and radiator. Remove air cleaner from the engine.

4. Disconnect both battery cables at the battery (see Battery Service in Chapter 5 - Electrical System).

5. Remove muffler from the exhaust manifold and muffler bracket (see Muffler Removal).

6. Drain radiator from the drain cock valve into a suitable container (see Radiator Removal). Disconnect coolant hoses from the water pump and engine block.

7. Remove coolant expansion tank and bracket from the top fan shroud. Remove top fan shroud from the radiator (see Radiator Removal).

8. Disconnect wire harness and electrical wires from the following:

- A. Battery and wire harness grounds (Fig. 21).
- B. Glow plug bus (Fig. 22) and fuel stop solenoid.
- C. High temperature warning switch (Fig. 23).
- D. High temperature shutdown switch, alternator, and low oil pressure switch (Fig. 24).

9. Disconnect throttle cable from the support and swivel on the speed control lever (Fig. 21).

10. Disconnect fuel hose from the fuel/water separator (Fig. 21) and front injector nozzle.

11. Remove traction control cable from the neutral arm assembly on the piston pump. Remove all hydraulic hoses from the piston and gear pumps (see Piston Pump Removal in Chapter 4- Hydraulic System).

12. Remove cable ties securing the wire harness to the front lift tab and other engine parts. Connect hoist or lift to the front and rear lift tabs (Fig. 22 and 23).

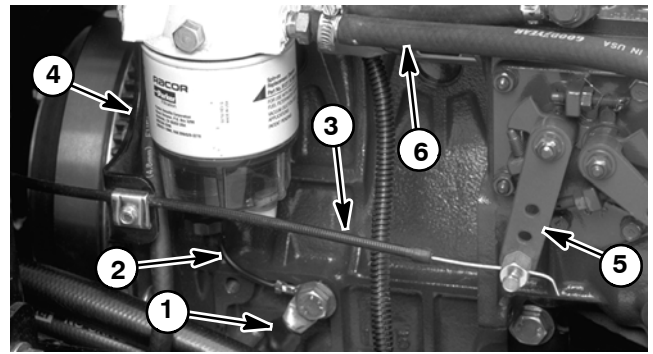

Figure 21

- |                         |                        |
|-------------------------|------------------------|
| 1. Battery ground cable | 4. Support bracket     |
| 2. Wire harness ground  | 5. Speed control lever |
| 3. Throttle cable       | 6. Fuel hose           |



**CAUTION**

**Make sure lift or hoist can support the total weight of the engine before removing the cap screws from the engine and engine brackets.**

13. Remove flange nuts, cap screws, and washers securing three engine mounts to the engine mounting brackets.



**CAUTION**

**One person should operate lift or hoist while the other person guides the engine out of the machine.**

**IMPORTANT: Make sure not to damage the engine, fuel and hydraulic lines, electrical harness, or other parts while removing the engine.**

14. Remove engine slowly from the machine.

15. Separate hydrostat and pump mount plate from the engine as follows (Figs. 25 and 26):

- A. Remove traction belt from the engine flywheel and hydrostat pulleys (see Replace Traction Belt).

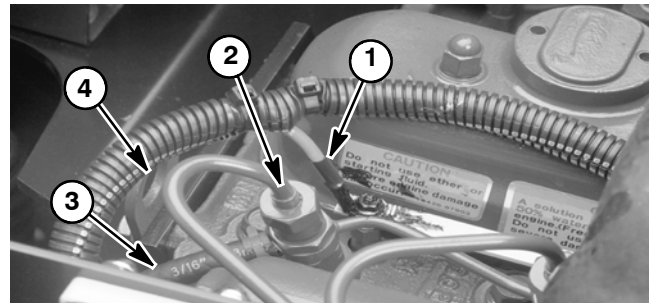

Figure 22

- |                         |                     |
|-------------------------|---------------------|
| 1. Glow plug wire       | 3. Fuel return hose |
| 2. Rear injector nozzle | 4. Rear lift tab    |

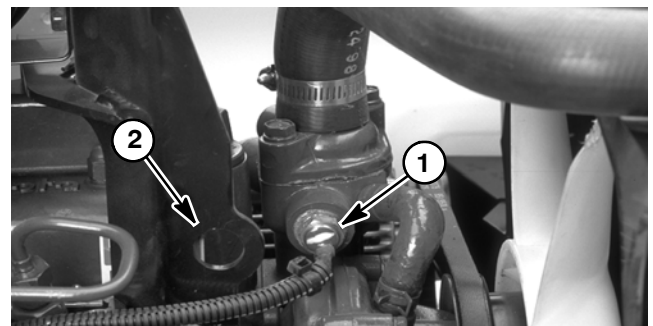

Figure 23

- |                         |                   |
|-------------------------|-------------------|
| 1. Temp. warning switch | 2. Front lift tab |
|-------------------------|-------------------|

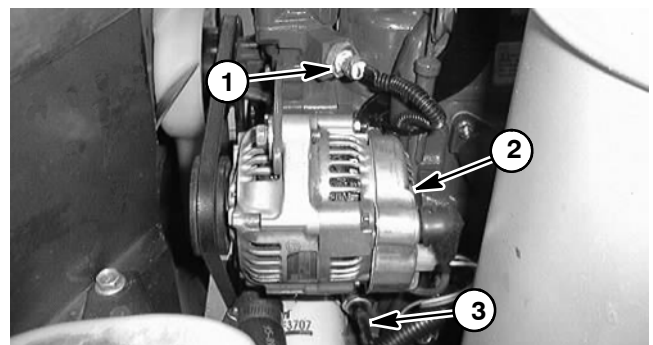

Figure 24

- |                          |                          |
|--------------------------|--------------------------|
| 1. Temp. shutdown switch | 3. Low oil press. switch |
| 2. Alternator            |                          |

**Note:** The cap screw next to the torsion spring does not have a flat washer with it.

B. Remove five cap screws, four washers, and five spacers securing the pump mount plate to the engine.

C. Remove four cap screws and hardened washers securing the right engine mounting bracket and hydrostat to the engine.

16. As necessary, remove engine mounts, front engine mounting bracket, throttle support bracket and left engine mounting bracket.

### Installation

1. If removed, install engine mounts, front engine mounting bracket, throttle support bracket and left engine mounting bracket. Also, make sure that all switches and sensors are installed on engine.

2. Install hydrostat and pump mount plate to the engine as follows (Figs. 25 and 26):

A. Secure right engine mounting bracket and hydrostat to the engine with four hardened washers and cap screws.

**Note:** Do not install flat washer with cap screw near the torsion spring to prevent the spring from binding.

B. Secure pump mount plate to the engine with five spacers, four washers, and five cap screws.

C. Install traction belt to the engine flywheel and hydrostat pulleys (see Replace Traction Belt).

3. Connect hoist or lift to the front and rear engine lift tabs (Fig. 22 and 23).

	<b>CAUTION</b>
<b>One person should operate lift or hoist while the other person guides the engine into the machine.</b>	

**IMPORTANT:** Make sure not to damage the engine, fuel and hydraulic lines, electrical harness, or other parts while installing the engine.

- 4. Position engine slowly into the machine.
- 5. Secure all three engine mounts to the engine mounting brackets with cap screws, washers, and flange nuts.
- 6. Secure wire harness to the front lift tab and the engine with cable ties.

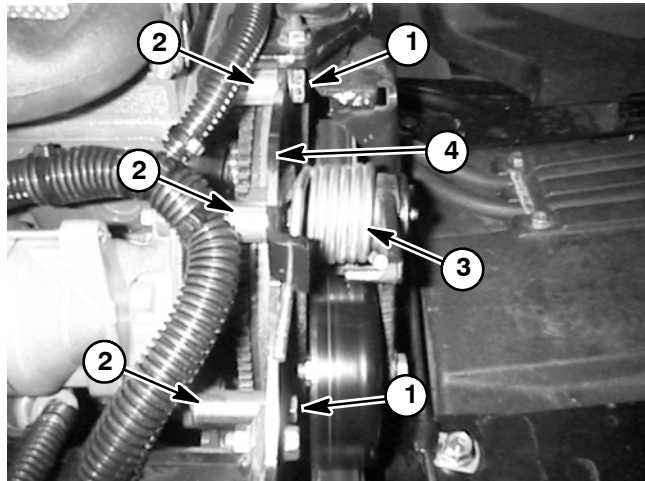

Figure 25

- |              |                     |
|--------------|---------------------|
| 1. Cap screw | 3. Torsion spring   |
| 2. Spacer    | 4. Pump mount plate |

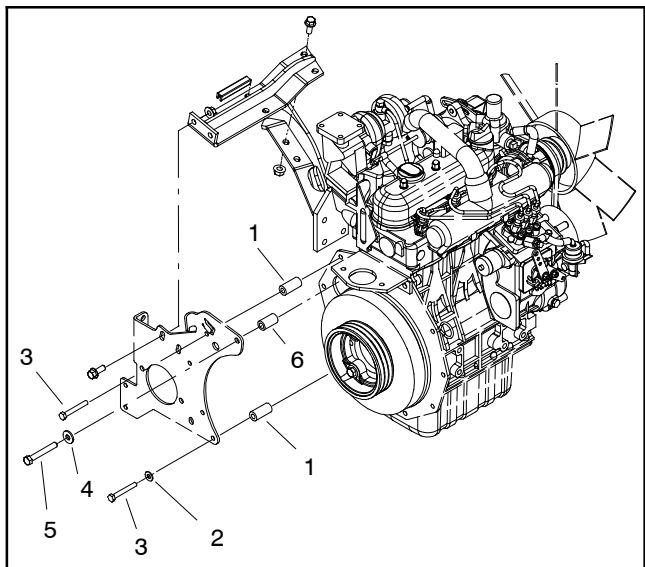

Figure 26

- |                            |                    |
|----------------------------|--------------------|
| 1. Long spacer (4 used)    | 4. Hardened washer |
| 2. Flat washer (3 used)    | 5. 10 mm cap screw |
| 3. 8 mm cap screw (4 used) | 6. Short spacer    |

7. Install all hydraulic hoses to the piston and gear pumps. Install traction control cable to the neutral arm assembly on the piston pump (see Piston Pump Installation in Chapter 4- Hydraulic System).

8. Connect fuel hose to the fuel/water separator (Fig. 21) and front injector nozzle.

9. Install top fan shroud to the radiator. Install expansion tank and bracket to the top fan shroud (see Radiator Installation).



10. Connect wire harness and electrical wires to the following:

- A. Engine grounds to the battery and wire harness (Fig. 21).
- B. Glow plug bus (Fig. 22) and fuel stop solenoid.
- C. High temperature warning switch (Fig. 23).
- D. High temperature shutdown switch, alternator, and low oil pressure switch (Fig. 24).

11. Secure wire harness to engine with cable ties at locations noted during engine removal.

12. Connect coolant hoses to the water pump and engine block. Make sure drain cock valve is closed. Fill radiator with coolant (see Check Cooling System).

13. Install muffler to the exhaust manifold and muffler bracket (see Muffler Installation).

14. Connect throttle cable to the support and swivel on the speed control lever (Fig. 21).

15. Connect both battery cables at the battery (see Battery Service in Chapter 5 - Electrical system).

16. Install air cleaner to the engine. Connect air hose to air cleaner and radiator.

17. Adjust throttle cable (see Adjust Throttle Cable).

18. Bleed fuel system (see Bleed Fuel System).

19. Install engine hood to the machine. Close and latch hood.

20. Check hydraulic oil level. Adjust as needed.

21. Adjust traction drive for neutral (see Adjust Traction Drive for Neutral in Chapter 4- Hydraulic System).

This page is intentionally blank.



# Hydraulic System

Hydraulic System

## Table of Contents

SPECIFICATIONS	2	Check Hydraulic Lines and Hoses	62
GENERAL INFORMATION	3	Flush Hydraulic System	63
Traction Unit Operator's Manual	3	Filtering Closed- Loop Traction Circuit	64
Check Hydraulic Fluid	3	Charge Hydraulic System	65
Towing Traction Unit	3	Hydraulic Tank and Hydraulic Oil Filter	66
Hydraulic Hoses	4	Oil Cooler	68
Hydraulic Hose and Tube Installation	5	Front Wheel Motors	70
Hydraulic Fitting Installation	6	Rear Wheel Motor	72
Relieving Hydraulic System Pressure	8	Wheel Motor Service	74
Traction Circuit (Closed Loop) Component Failure	8	Rotary Cutting Motors	76
HYDRAULIC SCHEMATICS	9	Rotary Cutting Motor Service (Haldex)	78
Serial Numbers Below 240000600	9	Rotary Cutting Motor Service (Casappa)	82
Serial Numbers 240000601 to 313999999	10	Hydraulic Manifold	84
Serial Numbers Above 314000000	11	Hydraulic Manifold Service (Serial Numbers Below 240000600)	86
HYDRAULIC FLOW DIAGRAMS	12	Hydraulic Manifold Service (Serial Numbers 240000601 to 313999999)	90
Traction Circuits	12	Hydraulic Manifold Service (Serial Numbers Above 314000000)	92
Cutting Unit Circuit	14	Control Valve	94
Lift Circuit (Up)	16	Control Valve Service	96
Lift Circuit (Down)	18	Piston Pump	100
Sidewinder Circuit	20	Piston Pump Service	104
Steering Circuit	22	Gear Pump	106
SPECIAL TOOLS	24	Gear Pump Service (Serial Numbers Below 260000400)	108
TROUBLESHOOTING	28	Gear Pump Service (Serial Numbers Above 260000400)	112
TESTING	30	Steering Control Valve	114
Traction Circuit Working Pressure Test	32	Steering Control Valve Service (Serial Numbers Below 240000000)	116
Piston Pump (P3) Flow & Traction Relief Pressure Test	34	Steering Control Valve Service (Serial Numbers Above 240000000)	117
Charge Relief Valve Pressure Test	36	Sidewinder	118
Gear Pump (P2) Flow Test	38	Front Lift Cylinder	120
Wheel Motor Efficiency Test	40	Rear Lift Cylinder	122
Cutting Deck Circuit Pressure Test	42	Lift Cylinder Service	124
Gear Pump (P1) Flow Test	44	Steering Cylinder	126
Manifold Relief Valve (R1) Pressure Test	46	Steering Cylinder Service	128
Logic (Counterbalance) Valve (LC1) Pressure Test	48	ROSS TORQMOTOR™ MG, MF, ME, AND MJ SERIES SERVICE PROCEDURE	
Deck Motor Efficiency - Case Drain Test	50	EATON MEDIUM DUTY PISTON PUMP REPAIR INFORMATION MODEL 70160 VARIABLE DISPLACEMENT PISTON PUMP	
Lift and Steering Control Valve Relief Pressure Test	52	ROSS HYDRAGUIDE™ HYDROSTATIC STEERING SYSTEM HGF SERIES SERVICE PROCEDURE	
Steering Control Valve Test	54	DANFOSS STEERING UNIT TYPE OSPM SERVICE MANUAL	
ADJUSTMENTS	56		
Adjust Traction Drive for Neutral	56		
Braking Valve Adjustment	57		
SERVICE AND REPAIRS	58		
General Precautions for Removing and Installing Hydraulic System Components	58		
Change Hydraulic Fluid	59		
Replace Hydraulic Oil Filter	60		
Replace Traction Belt	61		

# Specifications

Item	Description
Piston Pump (Hydrostat) Maximum Operating Pressure Charge Pressure Traction Circuit Relief Pressure (Forward Only)	Variable displacement piston pump 3000 PSI (207 bar) 100 to 150 PSI (6.9 to 10 bar) 3000 PSI (207 bar)
Gear Pump Maximum Operating Pressure	2 stage positive displacement gear type pump 3200 PSI (221 bar)
Wheel Motors (Front) Maximum Operating Pressure	Orbital rotor motor 2000 PSI (138 bar)
Wheel Motor (Rear) Maximum Operating Pressure	Orbital rotor motor 3000 PSI (207 bar)
Hydraulic Manifold Relief Pressure	3200 PSI (221 bar)
Cutting Unit Motor Cross-over Relief Pressure Maximum Operating Pressure	Gear motor 1500 PSI (103 bar) 2250 PSI (155 bar)
Steering Control Valve Maximum Operating Pressure Implement (Steering and Lift) Relief Valve Pressure	Distributor valve with rotary meter 1800 PSI (124 bar) 1000 PSI (69 bar)
Hydraulic Filter	10 Micron, spin- on cartridge type
Hydraulic Oil	See Hydraulic System Fluid in General Information Section
Hydraulic Reservoir	6 Gal. U.S. (22.6 L)

# General Information

## Traction Unit Operator's Manual

The Traction Unit Operator's Manual provides information regarding the operation, general maintenance and maintenance intervals for your Groundsmaster machine. Refer to that publication for additional information when servicing the machine.

### Check Hydraulic Fluid

The hydraulic system on Groundsmaster 3500- D machines is designed to operate on high quality hydraulic fluid. The hydraulic system reservoir holds approximately 6 gallons (22.6 liters) of hydraulic fluid. **Check level of hydraulic fluid daily.** See Traction Unit Operator's Manual for fluid level checking procedure and hydraulic oil recommendations.

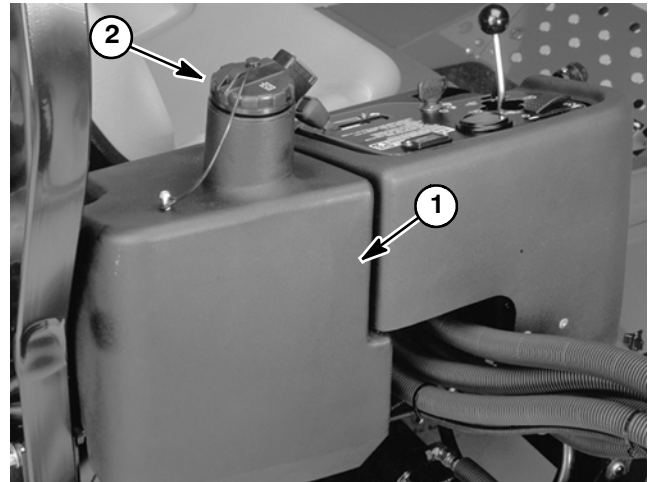

Figure 34

- 1. Hydraulic reservoir
- 2. Cap and dipstick

Hydraulic System

### Towing Traction Unit

In case of emergency, the Groundsmaster 3500- D can be towed for a short distance. However, Toro does not recommend this as a standard procedure.

1. Locate by-pass valve on hydrostat pump (Fig. 35) and rotate it 90° to open the by-pass valve. This open position should be horizontal (Fig. 36).

**IMPORTANT:** Do not tow the machine faster than 2 to 3 mph because the drive system may be damaged. If machine must be moved a considerable distance (more than a few feet), transport it on a truck or trailer.

2. Slowly tow machine.

3. Before starting engine, close by-pass valve by rotating it 90°. This closed position should be vertical (Fig. 36). Do not start engine when by-pass valve is open.

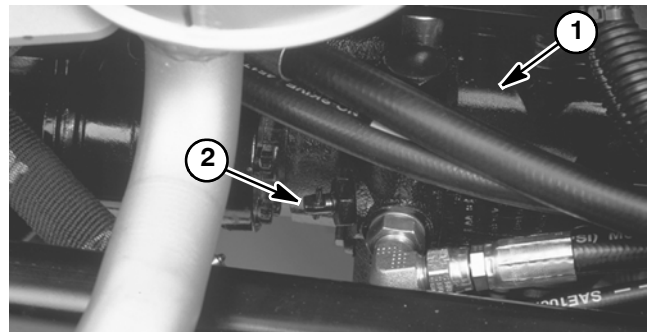

Figure 35

- 1. Hydrostat pump
- 2. By-pass valve

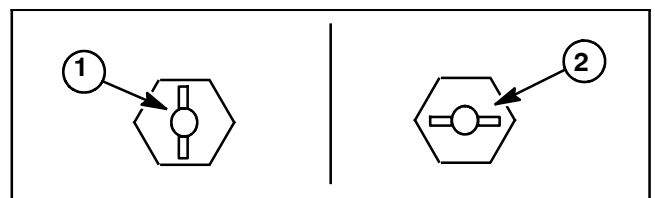

Figure 36

- 1. Valve closed position
- 2. Valve open position

---

## Hydraulic Hoses

Hydraulic hoses are subject to extreme conditions such as pressure differentials during operation and exposure to weather, sun, chemicals, very warm storage conditions or mishandling during operation and maintenance. These conditions can cause hose damage and deterioration. Some hoses are more susceptible to these conditions than others. Inspect all machine hydraulic hoses frequently for signs of deterioration or damage:

Hard, cracked, cut, abraded, charred, leaking or otherwise damaged hose.

Kinked, crushed, flattened or twisted hose.

Blistered, soft, degraded or loose hose cover.

Cracked, damaged or badly corroded hose fittings.

When replacing a hydraulic hose, be sure that the hose is straight (not twisted) before tightening the fittings. This can be done by observing the imprint (layline) on the hose. Use two wrenches when tightening a hose; hold the hose straight with one wrench and tighten the hose swivel nut onto the fitting with the second wrench (see Hydraulic Hose and Tube Installation in this section). If the hose has an elbow at one end, tighten the swivel nut on that end before tightening the nut on the straight end of the hose.

For additional hydraulic hose information, refer to Toro Service Training Book, Hydraulic Hose Servicing (Part Number 94813SL).



## WARNING

**Before disconnecting or performing any work on hydraulic system, relieve all pressure in system (see Relieving Hydraulic System Pressure in this section).**

**Keep body and hands away from pin hole leaks or nozzles that eject hydraulic fluid under high pressure. Use paper or cardboard, not hands, to search for leaks. Hydraulic fluid escaping under pressure can have sufficient force to penetrate the skin and cause serious injury. If fluid is injected into the skin, it must be surgically removed within a few hours by a doctor familiar with this type of injury. Gangrene may result from such an injury.**

## Hydraulic Hose and Tube Installation (O-Ring Face Seal Fitting)

1. Make sure threads and sealing surfaces of the hose/tube and the fitting are free of burrs, nicks, scratches or any foreign material.

2. As a preventative measure against leakage, it is recommended that the face seal O-ring be replaced any time the connection is opened. Make sure the O-ring is installed and properly seated in the fitting groove. Lightly lubricate the O-ring with clean hydraulic oil.

3. Place the hose/tube against the fitting body so that the flat face of the hose/tube sleeve fully contacts the O-ring in the fitting.

4. Thread the swivel nut onto the fitting by hand. While holding the hose/tube with a wrench, use a torque wrench to tighten the swivel nut to the recommended installation torque shown in Figure 39. This tightening process will require the use of an offset wrench (e.g. crowfoot wrench). Use of an offset wrench will affect torque wrench calibration due to the effective length change of the torque wrench. Tightening torque when using a torque wrench with an offset wrench will be lower than the listed installation torque (see Using a Torque Wrench with an Offset Wrench in the Torque Specifications section of Chapter 2 - Product Records and Maintenance).

5. If a torque wrench is not available or if space at the swivel nut prevents use of a torque wrench, an alternate method of assembly is the Flats From Wrench Resistance (F.F.W.R.) method (Fig. 2).

A. Using a wrench, tighten the swivel nut onto the fitting until light wrench resistance is reached (approximately 30 in-lb).

B. Mark the swivel nut and fitting body. Hold the hose/tube with a wrench to prevent it from turning.

C. Use a second wrench to tighten the nut to the correct Flats From Wrench Resistance (F.F.W.R.). The markings on the nut and fitting body will verify that the connection has been properly tightened.

Size	F.F.W.R.
4 (1/4 in. nominal hose or tubing)	1/2 to 3/4
6 (3/8 in.)	1/2 to 3/4
8 (1/2 in.)	1/2 to 3/4
10 (5/8 in.)	1/2 to 3/4
12 (3/4 in.)	1/3 to 1/2
16 (1 in.)	1/3 to 1/2

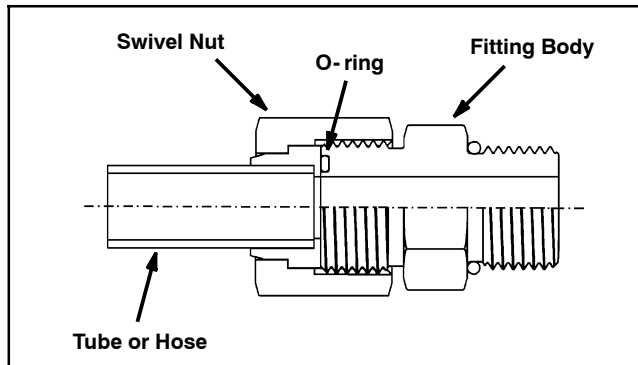

Figure 37

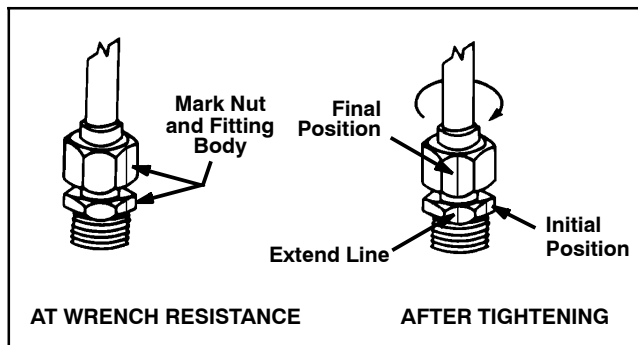

Figure 38

Fitting Dash Size	Hose/Tube Side Thread Size	Installation Torque
4	9/16 - 18	18 to 22 ft-lb (25 to 29 N-m)
6	11/16 - 16	27 to 33 ft-lb (37 to 44 N-m)
8	13/16 - 16	37 to 47 ft-lb (51 to 63 N-m)
10	1 - 14	60 to 74 ft-lb (82 to 100 N-m)
12	1 3/16 - 12	85 to 105 ft-lb (116 to 142 N-m)
16	1 7/16 - 12	110 to 136 ft-lb (150 to 184 N-m)
20	1 11/16 - 12	140 to 172 ft-lb (190 to 233 N-m)

Figure 39

## Hydraulic Fitting Installation (SAE Straight Thread O-Ring Fitting into Component Port)

### Non-Adjustable Fitting (Fig. 40)

1. Make sure all threads and sealing surfaces of fitting and component port are free of burrs, nicks, scratches or any foreign material.
2. As a preventative measure against leakage, it is recommended that the O-ring be replaced any time the connection is opened.
3. Lightly lubricate the O-ring with clean hydraulic oil. Fitting threads should be clean with no lubricant applied.

**IMPORTANT: Before installing fitting into port, determine port material. If fitting is to be installed into an aluminum port, installation torque is reduced.**

4. Install the fitting into the port. Then, use a torque wrench and socket to tighten the fitting to the recommended installation torque shown in Figure 41.

**NOTE:** Use of an offset wrench (e.g. crowfoot wrench) will affect torque wrench calibration due to the effective length change of the torque wrench. Tightening torque when using a torque wrench with an offset wrench will be less than the recommended installation torque. See Using a Torque Wrench with an Offset Wrench in the Torque Specifications section of Chapter 2 - Product Records and Maintenance to determine necessary conversion information.

5. If a torque wrench is not available, or if space at the port prevents use of a torque wrench, an alternate method of assembly is the Flats From Finger Tight (F.F.F.T.) method.

A. Install the fitting into the port and tighten it down full length until finger tight.

B. If port material is steel, tighten the fitting to the listed F.F.F.T. If port material is aluminum, tighten fitting to 60% of listed F.F.F.T.

Size	F.F.F.T.
4 (1/4 in. nominal hose or tubing)	1.00 ± 0.25
6 (3/8 in.)	1.50 ± 0.25
8 (1/2 in.)	1.50 ± 0.25
10 (5/8 in.)	1.50 ± 0.25
12 (3/4 in.)	1.50 ± 0.25
16 (1 in.)	1.50 ± 0.25

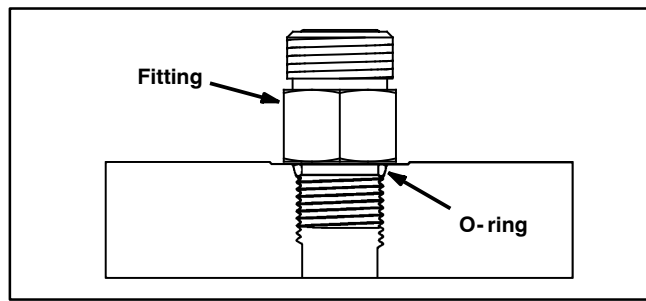

Figure 40

Fitting Dash Size	Fitting Port Side Thread Size	Installation Torque Into Steel Port	Installation Torque Into Aluminum Port
4	7/16 - 20	15 to 19 ft-lb (21 to 25 N-m)	9 to 11 ft-lb (13 to 15 N-m)
5	1/2 - 20	18 to 22 ft-lb (25 to 29 N-m)	11 to 15 ft-lb (15 to 20 N-m)
6	9/16 - 18	34 to 42 ft-lb (47 to 56 N-m)	20 to 26 ft-lb (28 to 35 N-m)
8	3/4 - 16	58 to 72 ft-lb (79 to 97 N-m)	35 to 43 ft-lb (48 to 58 N-m)
10	7/8 - 14	99 to 121 ft-lb (135 to 164 N-m)	60 to 74 ft-lb (82 to 100 N-m)
12	1 1/16 - 12	134 to 164 ft-lb (182 to 222 N-m)	81 to 99 ft-lb (110 to 134 N-m)
14	1 3/16 - 12	160 to 196 ft-lb (217 to 265 N-m)	96 to 118 ft-lb (131 to 160 N-m)
16	1 5/16 - 12	202 to 248 ft-lb (274 to 336 N-m)	121 to 149 ft-lb (165 to 202 N-m)
20	1 5/8 - 12	247 to 303 ft-lb (335 to 410 N-m)	149 to 183 ft-lb (202 to 248 N-m)

Figure 41



**Adjustable Fitting (Fig. 42)**

1. Make sure all threads and sealing surfaces of fitting and component port are free of burrs, nicks, scratches or any foreign material.
2. As a preventative measure against leakage, it is recommended that the O-ring be replaced any time the connection is opened.
3. Lightly lubricate the O-ring with clean hydraulic oil. Fitting threads should be clean with no lubricant applied.
4. Turn back the lock nut as far as possible. Make sure the back up washer is not loose and is pushed up as far as possible (Step 1 in Figure 43).

**IMPORTANT: Before installing fitting into port, determine port material. If fitting is to be installed into an aluminum port, installation torque is reduced.**

5. Install the fitting into the port and tighten finger tight until the washer contacts the face of the port (Step 2 in Figure 43). Make sure that the fitting does not bottom in the port during installation.
6. To put the fitting in the desired position, unscrew it by the required amount to align fitting with incoming hose or tube, but no more than one full turn (Step 3 in Figure 43).
7. Hold the fitting in the desired position with a wrench and use a torque wrench to tighten the lock nut to the recommended installation torque shown in Figure 41. This tightening process will require the use of an offset wrench (e.g. crowfoot wrench). Use of an offset wrench will affect torque wrench calibration due to the effective length change of the torque wrench. Tightening torque when using a torque wrench with an offset wrench will be lower than the listed installation torque (see Using a Torque Wrench with an Offset Wrench in the Torque Specifications section of Chapter 2 - Product Records and Maintenance).
8. If a torque wrench is not available, or if space at the port prevents use of a torque wrench, an alternate method of assembly is the Flats From Finger Tight (F.F.F.T.) method. Hold the fitting in the desired position with a wrench and, if port material is steel, tighten the lock nut with a second wrench to the listed F.F.F.T. (Step 4 in Figure 43). If port material is aluminum, tighten fitting to 60% of listed F.F.F.T.

Size	F.F.F.T.
4 (1/4 in. nominal hose or tubing)	1.00 ± 0.25
6 (3/8 in.)	1.50 ± 0.25
8 (1/2 in.)	1.50 ± 0.25
10 (5/8 in.)	1.50 ± 0.25
12 (3/4 in.)	1.50 ± 0.25
16 (1 in.)	1.50 ± 0.25

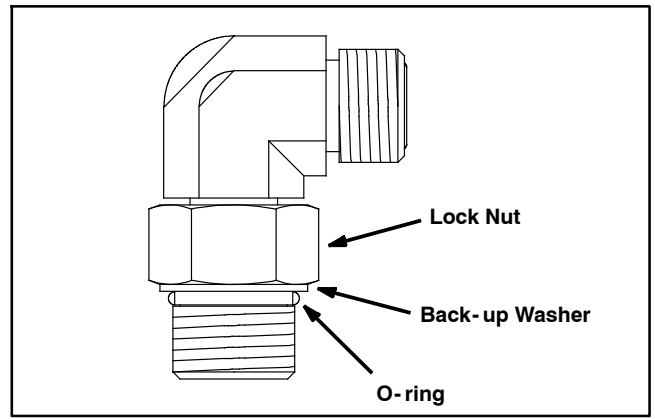

Figure 42

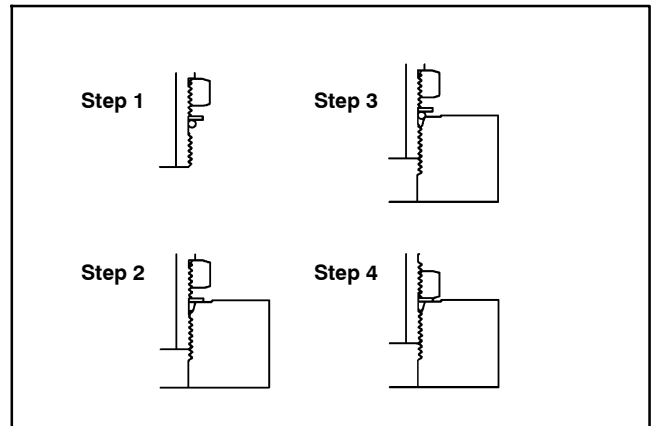

Figure 43

---

## Relieving Hydraulic System Pressure

Before disconnecting or performing any work on the Groundsmaster 3500- D hydraulic system, all pressure in the hydraulic system must be relieved. Park machine on a level surface with the cutting units lowered and off. Turn key switch to OFF and allow engine to stop.

To relieve hydraulic pressure in traction circuit, move traction lever to both forward and reverse directions. To relieve hydraulic pressure in steering and lift circuits, rotate steering wheel in both directions.

To relieve cutting unit system pressure, turn key switch to ON (engine not running). Move PTO switch to engage

which will energize the solenoid valve on hydraulic manifold to relieve circuit pressure. Move PTO switch to disengage, return key switch to OFF and remove key from the ignition switch.

**NOTE:** Moving steering wheel with engine off may unseat implement relief valve. If steering or lift circuits appear weak or inoperative after machine is returned to service, repeat relieving hydraulic system pressure procedure.

---

## Traction Circuit (Closed Loop) Component Failure

The Groundsmaster 3500- D traction circuit is a closed loop system that includes the hydrostat and two (2) wheel motors. If a component in the traction circuit should fail, debris and contamination from the failed component will circulate throughout the traction circuit. This contamination can damage other components in the circuit so it must be removed to prevent additional component failure.

If a component failure occurs in the traction circuit, it is critical that the entire traction circuit be disassembled, drained and thoroughly cleaned to ensure that all contamination is removed from the circuit. If any debris remains in the traction circuit and the machine is operated, the debris can cause additional component failure.

An additional step for removing all traction circuit contamination would be to temporarily install a high pressure hydraulic oil filter (see Special Tools) into the circuit. The filter could be used when connecting hydraulic test gauges in order to test traction circuit components or after replacing a failed traction circuit component (e.g. hydrostat or wheel motor). The filter will ensure that contaminants are removed from the closed loop and thus, do not cause additional component damage.

Once the filter has been placed in the traction circuit, place the machine on jack stands and operate the traction circuit to allow oil flow through the circuit. With the machine raised off the ground, the traction circuit will have maximum oil flow at minimum pressure to minimize damage from any remaining contamination. The filter will remove contamination from the closed loop traction circuit during operation. Remove the filter from the machine after contamination has been removed from the traction circuit.

**IMPORTANT:** When operating the traction system with the high pressure filter installed, make sure that flow is always directed through the filter (e.g. do not press the traction pedal in the reverse direction if the filter is placed for forward direction flow). If flow is reversed, debris from the filter will re- enter the traction circuit.

# Hydraulic Schematics

Groundsmaster 3500 - D  
**Hydraulic Schematic**  
 (Serial Numbers Below 2400006000)

All solenoids are shown as de-energized

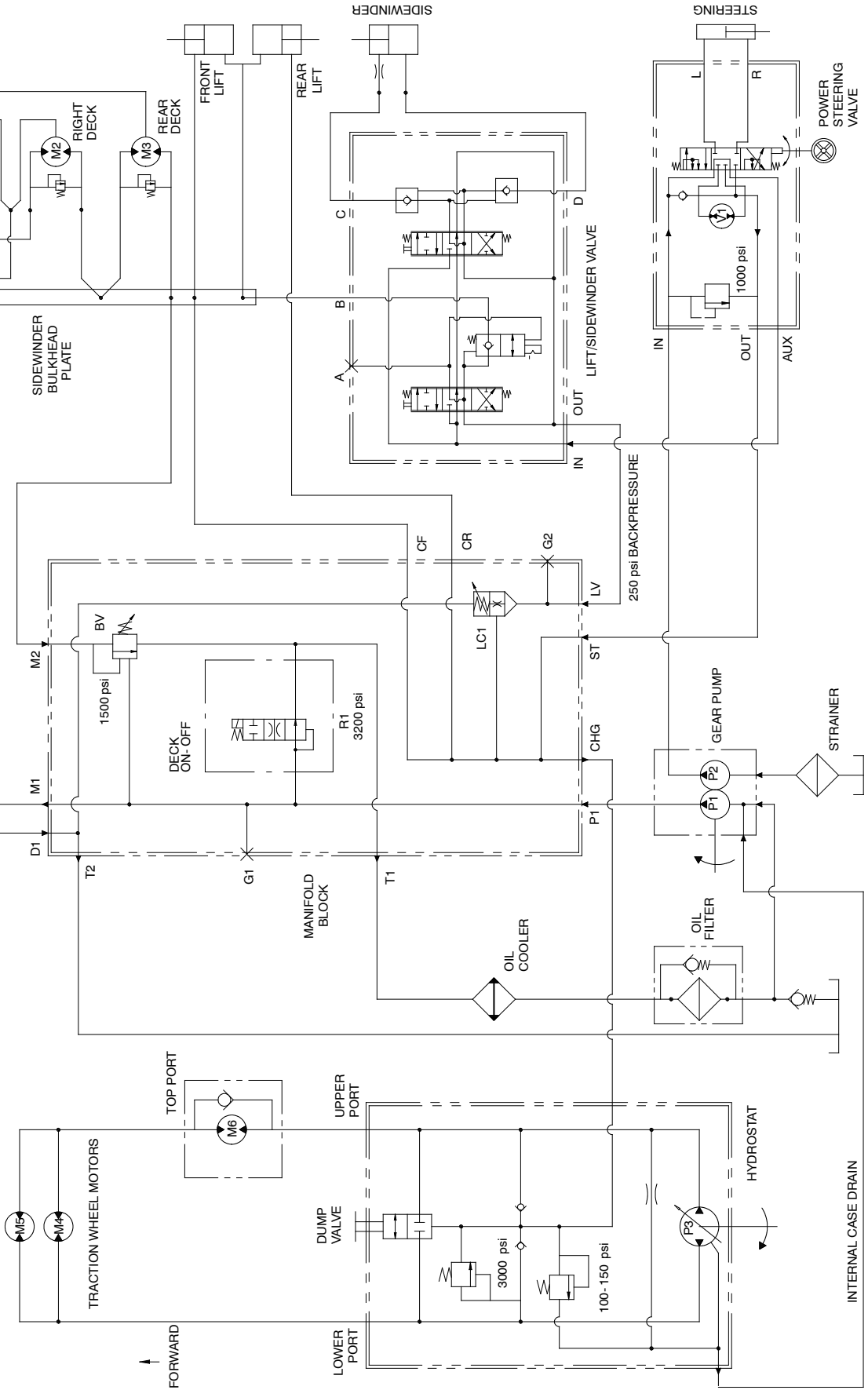

Hydraulic System



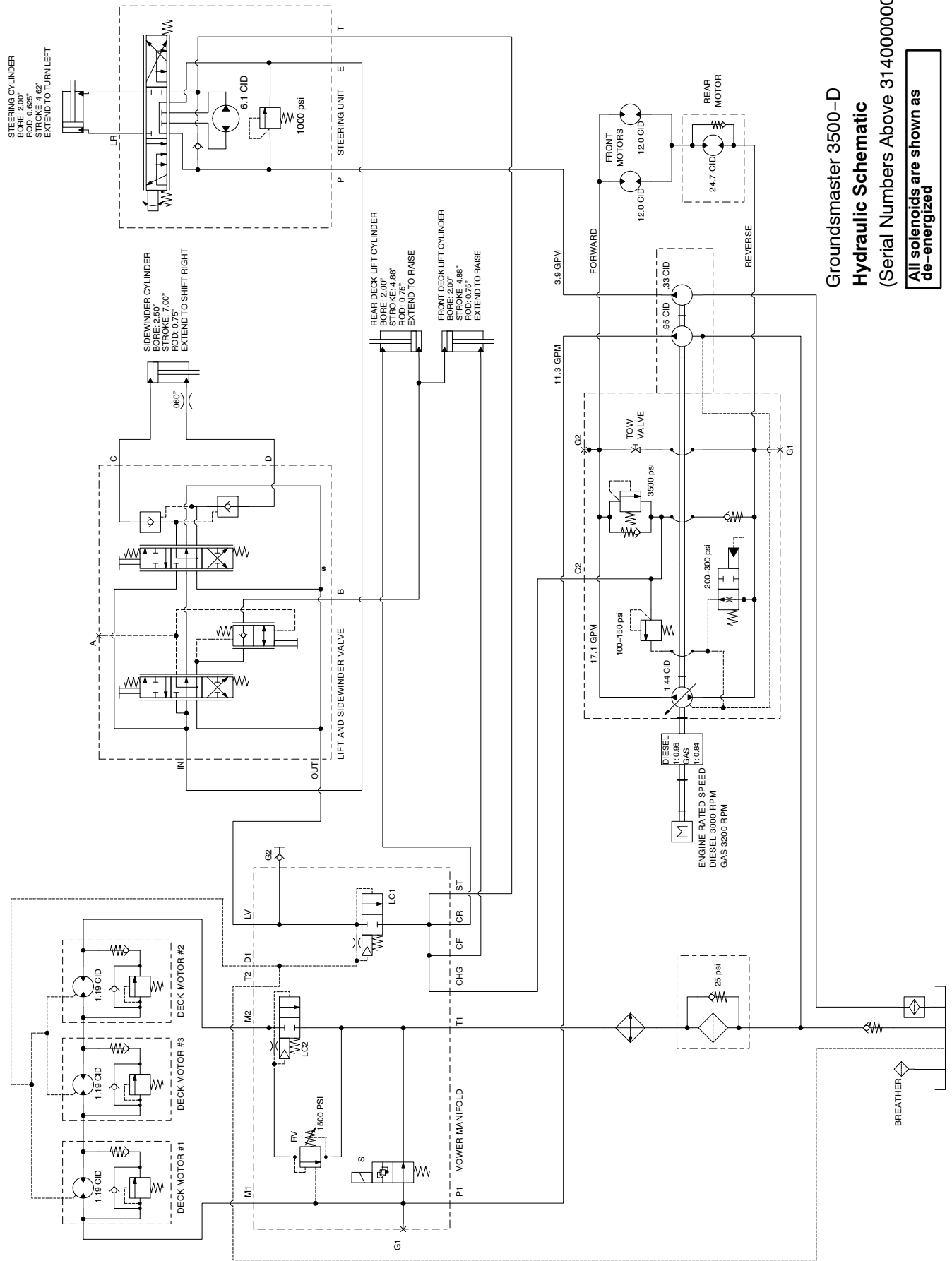

Groundsmaster 3500-D  
**Hydraulic Schematic**  
 (Serial Numbers Above 31400000C  
 All solenoids are shown as de-energized)

**Hydraulic System**

# Hydraulic Flow Diagrams

## Groundmaster 3500 - D Traction Circuits (Forward)

- High Pressure
- - - Low Pressure (Charge)
- Return or Suction
- ▶ Flow

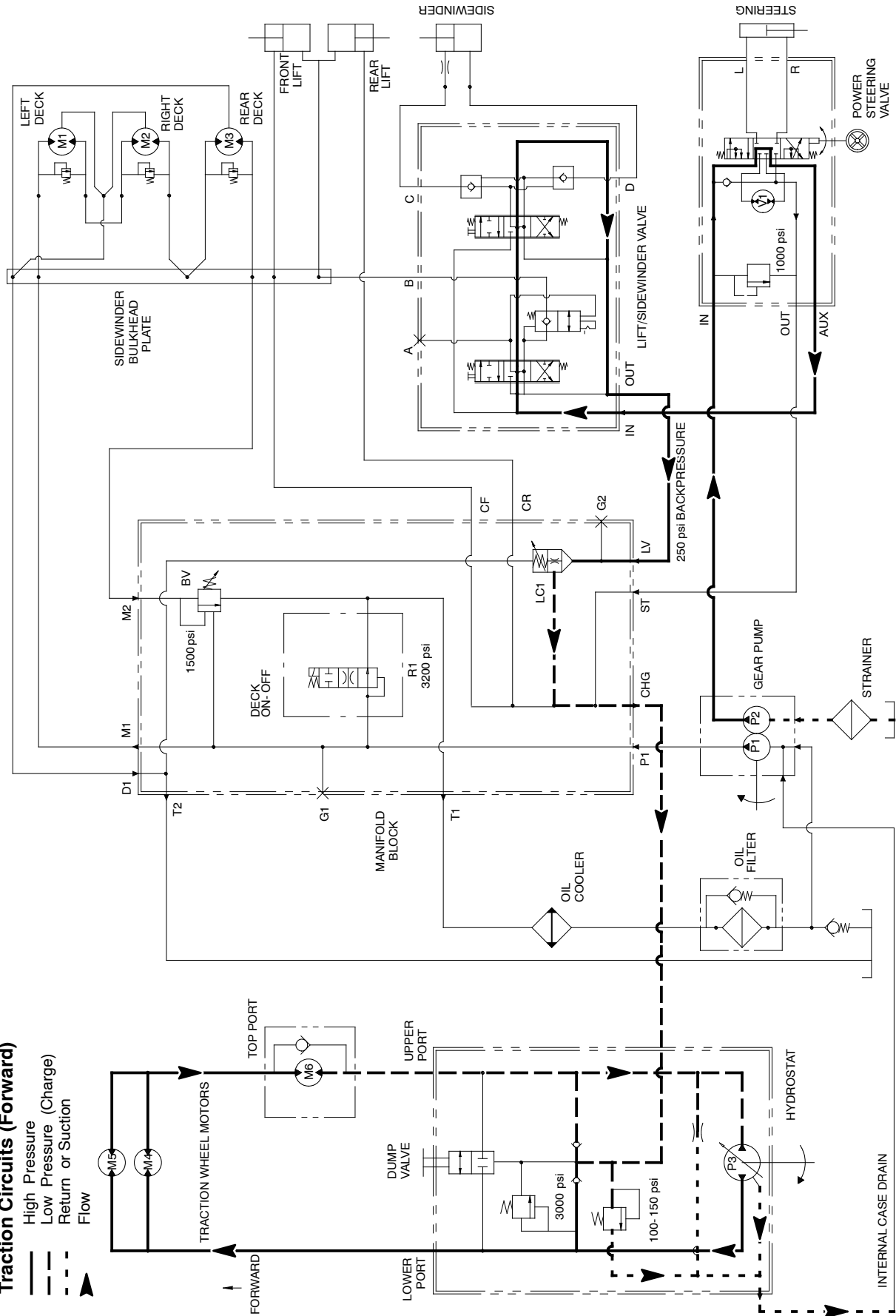

---

## Traction Circuits

### Forward

The traction circuit of the hydraulic system consists of a hydrostat connected in a closed loop circuit to three orbital vane wheel motors.

The engine drives traction pump (P3) indirectly through pulleys and a V-belt. The traction pump is a variable displacement piston pump. The traction pedal connects through a cable to the trunnion shaft and swash plate of the pump. With the engine running and the traction pedal in the neutral position, traction pump (P3) supplies no flow to the wheel motors. When the traction pedal is pressed to the forward position, the cable from the pedal positions the swash plate in the traction pump so oil flows out of the lower port. Oil flow out of the lower port goes to the wheel motors and turns them in the forward direction. Oil flowing out of the wheel motors returns to the upper port of the hydrostat and is continuously pumped out of the lower port.

The rear wheel motor has a small check valve across its ports that allows the rear motor to over run during tight turns in the forward direction.

The traction pump uses a small amount of hydraulic fluid for internal lubrication. Fluid is designed to leak across pump parts into the case drain. This leakage results in

the loss of hydraulic fluid from the closed loop circuit that must be replenished.

The charge pump (P2) is a fixed displacement gear pump. It is driven directly off the traction pump. The pump replenishes the closed loop traction circuit with fluid from the hydraulic tank. The charge relief valve supplies sufficient pressure so that charge pump flow is guided to the low pressure side of the traction circuit through one of two check valves. Pump flow in excess of replenishment requirements is relieved through the charge relief valve back to the gear pump inlet.

### Reverse

The traction circuit operates essentially the same in reverse as it does in forward. However, there are a few differences in operation.

When the reverse traction pedal is depressed, the cable from the pedal positions the swash plate in the traction pump (P3) so oil flows out of the upper port. Oil flow out of the upper port goes to the wheel motors and turns them in the reverse direction. Oil flowing out of the wheel motors returns to the lower port of the hydrostat and is continuously pumped out of the upper port. Oil bypasses the rear motor in reverse because of the check valve inside the rear wheel motor.

Groundmaster 3500-D

**Cutting Unit Circuit**

High Pressure  
 Low Pressure (Charge)  
 Return or Suction  
 Flow

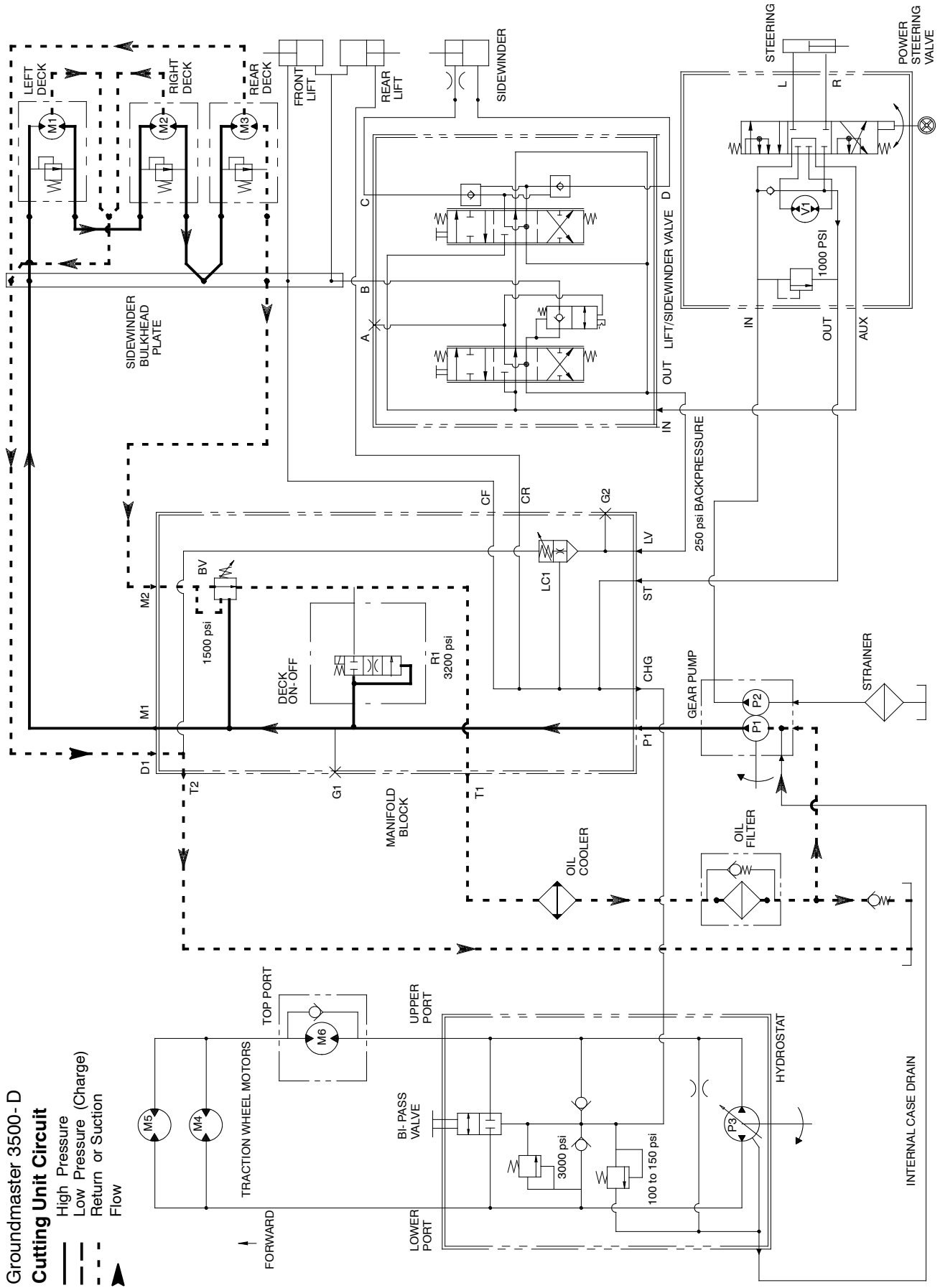



---

## Cutting Unit Circuit

### Mow

The gear pump (P1) is directly coupled to the the hydrostat which is driven by the engine. Taking its suction directly from the hydraulic tank, the gear pump (P1) supplies oil flow to the manifold block and to the cutting unit motors.

Solenoid valve (R1) is de-energized with the engine running when either the cutting unit drive switch is in DISENGAGE or the transport/mow slide is in TRANSPORT. Solenoid valve (R1) by-passes flow from the cutting unit motors directly to the hydraulic reservoir.

Solenoid valve (R1) is energized with the engine running when the cutting unit drive switch is in ENGAGE and the transport/mow slide is in MOW. When energized, solenoid valve (R1) allows gear pump (P1) flow out manifold block port M1 to the cutting unit motors. When solenoid valve (R1) is energized, brake relief cartridge (BV) is shifted (opens) to allow oil return from the cutting unit motors.

Oil flows through the left, right, and then rear cutting unit motors as it turns the motors. The oil then returns into manifold block port (M2), the oil cooler, the oil filter and to gear pump (P1) inlet.

If cutting unit circuit pressure exceeds relief pressure of 3200 PSI (221 bar), solenoid valve (R1) shifts to allow circuit pressure relief.

### Cutting Unit Blade Braking

When the solenoid valve (R1) is de-energized as the PTO switch is DISENGAGED, brake relief cartridge (BV) shifts to its closed position, blocking return flow from the deck motors and slowing the cutting blades

The inertia of the rotating cutting blades, however, effectively turns the deck motors into pumps causing an increase in pressure as the flow from the motors comes up against the closed brake relief cartridge (BV). When this pressure builds to approximately 1500 PSI (103 bar), brake relief cartridge (BV) opens which allows hydraulic flow to return to tank and reduces return pressure. When return pressure drops below 1500 PSI (103 bar), brake relief cartridge (BV) reseats to further slow the cutting blades. This action repeats several times in a very short time frame as the blades finally come to a stop. Once the blades have stopped, brake relief cartridge (BV) remains closed to keep the deck motors from rotating.

Groundmaster 3500-D

Lift Circuit (Up)

- High Pressure
- Low Pressure (Charge)
- Return or Suction
- Flow

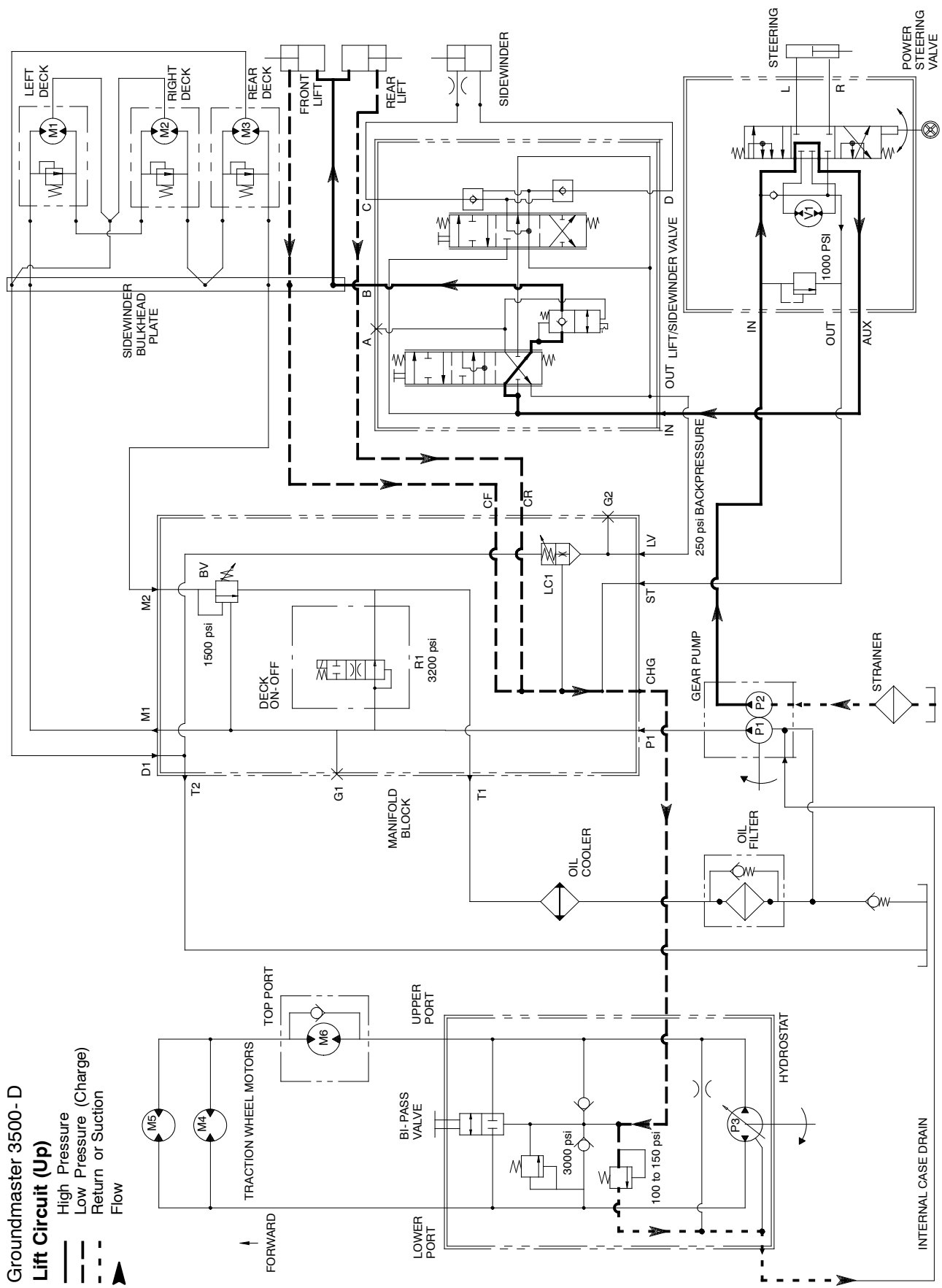

---

## Lift Circuit (Up)

### Raise Cutting Units

The gear pump (P2) is directly coupled to the hydrostat through gear pump (P1). It supplies hydraulic pressure (charge pressure) for operating the power steering system, raising and lowering the cutting units, operating the sidewinder unit, and maintaining 100 to 150 PSI (6.9 to 10.0 bar) to the low pressure side of the traction circuit. The pump takes its suction from the hydraulic reservoir.

During conditions of not lifting or lowering cutting units, flow from the gear pump (P2) is by-passed through the power steering valve, 2- spool lift/sidewinder valve, and hydraulic manifold directly to the hydrostat and the charge relief valve. Flow then returns to the hydraulic tank.

When the cutting units are to be raised, the 2- spool valve is positioned by moving the cutting unit shift lever to RAISE. Flow is directed to cap ends of the lift cylinders. Hydraulic pressure against the cylinder pistons moves their shafts causing the cutting units to raise. At the same time, the pistons push the hydraulic fluid out of the lift cylinders and back through the hydraulic manifold to the hydrostat.

When the cutting unit shift lever is released, spring action returns the valve to its original position and by-passes flow back to the hydrostat stopping lift cylinder movement. The cylinder position is locked in place by the load holding checks in the lift control valve.

Groundmaster 3500-D

**Lift Circuit (Down)**

- High Pressure
- - - Low Pressure (Charge)
- Return or Suction
- ▲ Flow

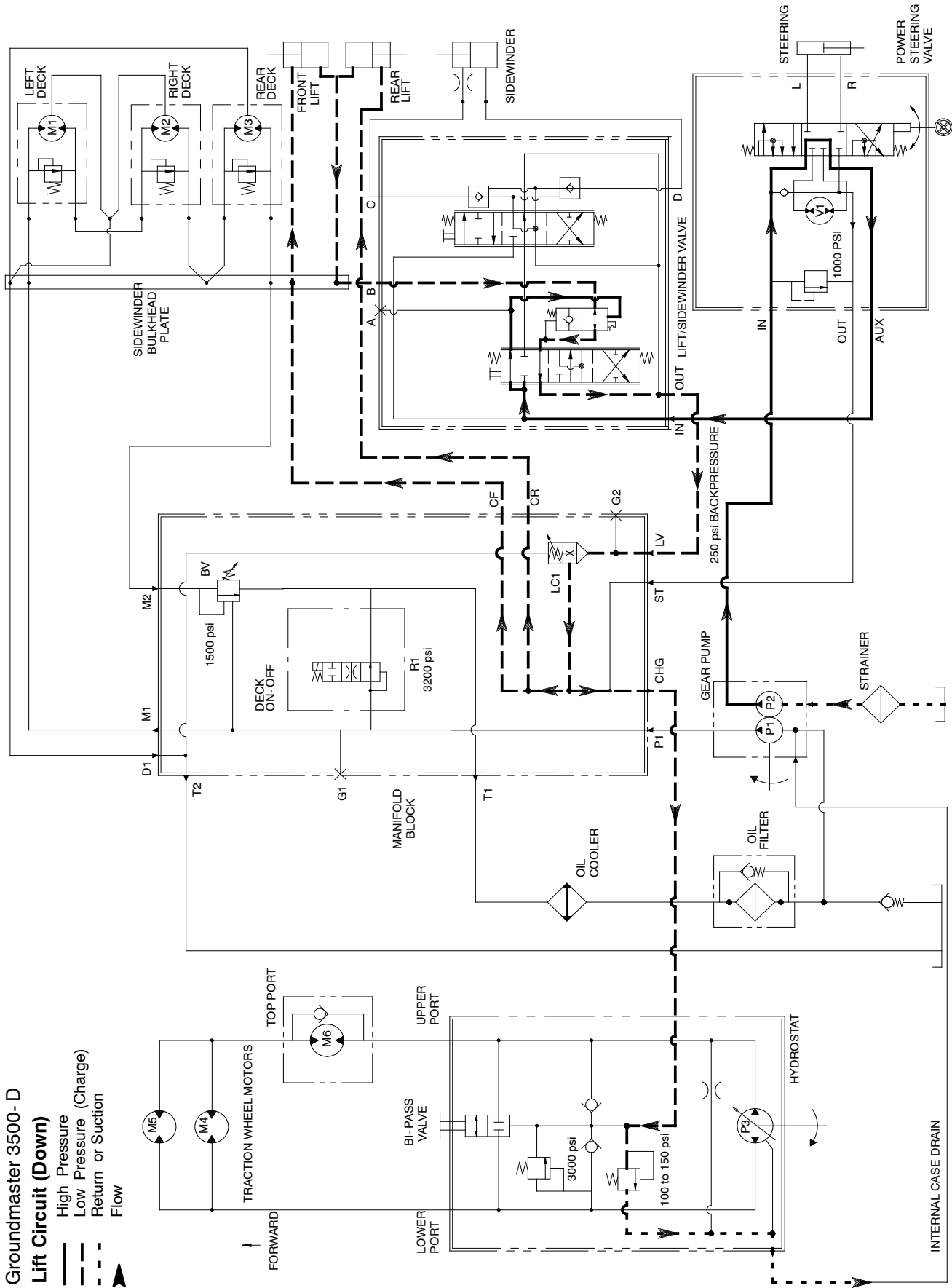

---

## Lift Circuit (Down)

### Lower Cutting Units

Circuit operation for lowering the cutting units is similar to raising them. However, pressure is relieved from the lift cylinders, and this action allows them to lower.

During conditions of not lifting or lowering cutting units, flow from the gear pump is by-passed through the power steering valve, 2- spool lift/sidewinder valve, and hydraulic manifold directly to the hydrostat and the charge relief valve. Flow then returns to gear pump (P1) inlet.

When the cutting units are to be lowered, the 2- spool valve is positioned by moving the cutting unit shift lever to LOWER. Pressure from gear pump (P2) is used to shift the pilot valve in the 2- spool valve. This shifting of the pilot valve allows hydraulic pressure to relieve from

the cap end of the lift cylinders. Flow from the cap end of the lift cylinders causes the cutting units to lower. At the same time, the fluid relieved from the cap end of the lift cylinders goes into the rod end of the cylinders and back through the hydraulic manifold to the hydrostat.

When the cutting unit shift lever is released, spring action returns and detents the valve into the float position while by-passing flow back to the hydrostat. The pilot valve remains shifted to allow the lift cylinders to float until the lift control valve is moved to the raise position.

The logic cartridge valve (LC1) in the manifold block maintains 250 PSI (17.2 bar) back pressure on the lift cylinders. This counterbalance pressure transfers cutting unit weight to the machine to improve traction.

**Groundmaster 3500- D  
Sidewinder Circuit (Extend Right)**

High Pressure  
Low Pressure (Charge)  
Return or Suction  
Flow

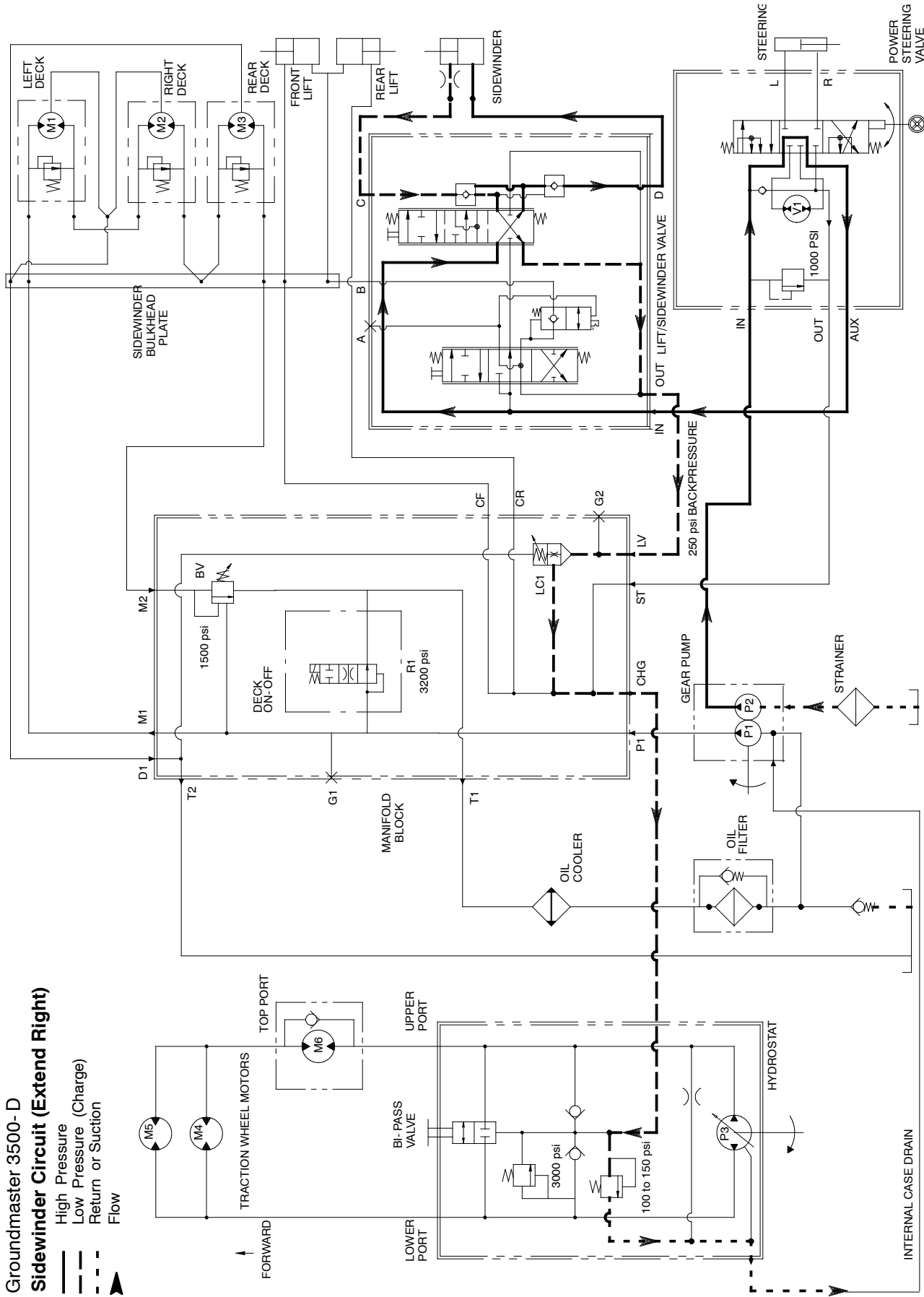

---

## Sidewinder Circuit

The gear pump (P2) is directly coupled to the hydrostat through gear pump (P1). It supplies hydraulic pressure (charge pressure) for operating the power steering system, raising and lowering the cutting units, operating the sidewinder unit, and maintaining 100 to 150 PSI (6.9 to 10.0 bar) to the low pressure side of the traction circuit. The pump takes its suction from the hydraulic reservoir.

During conditions of not lifting or lowering the cutting units, flow from the gear pump is by-passed through the power steering valve, 2- spool lift/sidewinder valve, and hydraulic manifold directly to the hydrostat and the charge relief valve. Flow then returns to the hydraulic tank.

### Shift Sidewinder Right

When the sidewinder is to be shifted right, the 2- spool valve is positioned by moving the cutting unit shift lever to RIGHT. Flow is directed to the cap end of the sidewinder cylinder. Hydraulic pressure against the cylinder piston moves the rod causing the sidewinder cylinder to extend right. At the same time, the piston pushes the hy-

draulic fluid out of the cylinder, back through the spool and hydraulic manifold, and to the hydrostat. When the cutting unit shift lever is released, spring action returns the valve to its original position and by-passes flow back to the hydrostat and stopping cylinder movement. The cylinder position is locked in place since there is no complete circuit of flow to and from the sidewinder cylinder.

### Shift Sidewinder Left

When the sidewinder is to be shifted left, the 2- spool valve is positioned by moving the cutting unit shift lever to LEFT. Flow is directed to the rod end of the sidewinder cylinder. Hydraulic pressure against the cylinder piston moves the rod causing the sidewinder to retract left. At the same time, the piston pushes the hydraulic fluid out of the cylinder, back through the spool and hydraulic manifold, and to the hydrostat. When the cutting unit shift lever is released, spring action returns the valve to its original position and by-passes flow back to the hydrostat stopping cylinder movement. The cylinder position is locked in place.

Groundmaster 3500-D

**Steering Circuit (Right Turn)**

- High Pressure
- - - Low Pressure (Charge)
- · - · - Return or Suction
- ▲ Flow

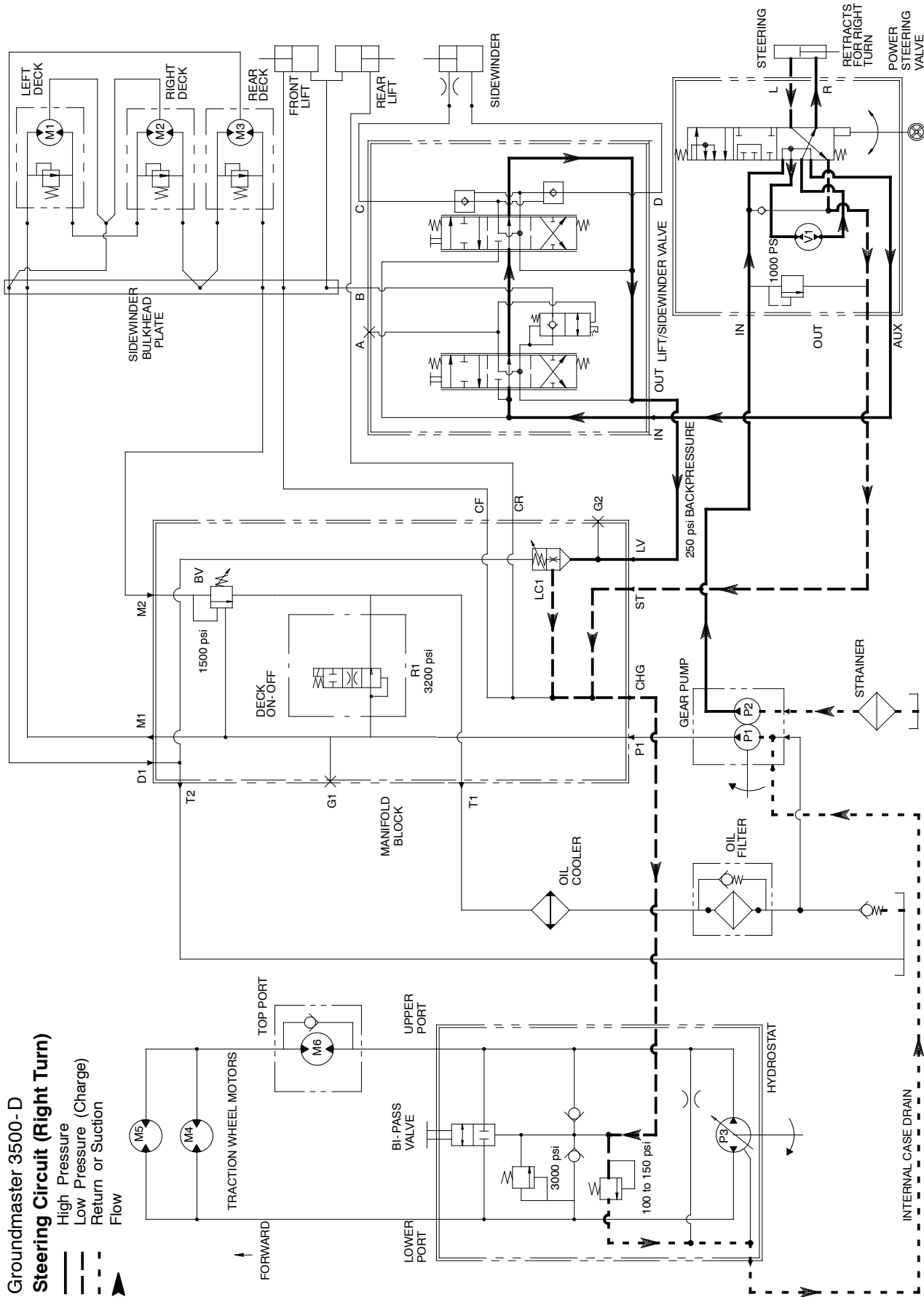



---

## Steering Circuit

The gear pump (P2) is directly coupled to the hydrostat. It supplies hydraulic pressure to the power steering valve for turning the rear wheel and maintaining 100 to 150 PSI (6.9 to 10.0 Bar) to the low pressure side of the traction circuit. The pump takes its suction from the hydraulic reservoir.

With the steering wheel in the neutral position (rear wheel positioned straight ahead), the engine running, and the spool valve in the center position, flow enters the steering control valve at the IN port and goes through the spool valve, by-passing the rotary meter (V1) and steering cylinder. Flow leaves the control valve through the AUX port to the hydrostat to be available for the lift circuit and then to the hydrostat (charge).

### Right Turn

When a right turn is made with the engine running, the turning of the steering wheel positions the spool valve so that flow goes through the bottom of the spool. Flow entering the steering control valve at the IN port goes through the spool and is routed to two places. First, most of the flow through the valve is by-passed out the AUX port back through the 2-spool valve to the hydrostat. Second, the remainder of the flow is drawn through the rotary meter (V1) and out port (R). Pressure retracts the piston for a right turn. The rotary meter (V1) ensures that

the oil flow to the cylinder is proportional to the amount of the turning on the steering wheel. Fluid leaving the cylinder flows back through the spool valve then through the OUT port and to the hydrostat.

The steering control valve returns to the neutral position when turning is complete.

### Left Turn

When a left turn is made with the engine running, the turning of the steering wheel positions the spool valve so that flow goes through the top of the spool. Flow entering the steering control valve at the IN port goes through the spool and is routed to two places. As in a right turn, most of the flow through the valve is by-passed out the AUX port back through the 2-spool valve to the hydrostat. Also like a right turn, the remainder of the flow is drawn through rotary meter (V1) but goes out port (L). Pressure extends the piston for a left turn. The rotary meter (V1) ensures that the oil flow to the cylinder is proportional to the amount of the turning on the steering wheel. Fluid leaving the cylinder flows back through the spool valve then through the OUT port and to the hydrostat.

The steering control valve returns to the neutral position when turning is complete.

# Special Tools

Order these special tools from your Toro Distributor.

---

## Hydraulic Pressure Test Kit

Toro Part Number: **TOR47009**

Use to take various pressure readings for diagnostic tests. Quick disconnect fittings provided attach directly to mating fittings on machine test ports without tools. A high pressure hose is provided for remote readings. Contains one each: 1000 PSI (70 Bar), 5000 PSI (350 Bar) and 10000 PSI (700 Bar) gauges. Use gauges as recommended in Testing section of this chapter.



Figure 44

---

## Hydraulic Tester (Pressure and Flow)

Toro Part Number: **TOR214678**

This tester requires O-ring Face Seal (ORFS) adapter fittings for use on this machine (see Hydraulic Test Fitting Kit - TOR4079 in this section).

1. **INLET HOSE:** Hose connected from the system circuit to the inlet side of the hydraulic tester.
2. **LOAD VALVE:** A simulated working load is created in the circuit by turning the valve to restrict flow.
3. **LOW PRESSURE GAUGE:** Low range gauge to provide accurate reading at low pressure: 0 to 1000 PSI.

A protector valve cuts out when pressure is about to exceed the normal range for the gauge. The cutout pressure is adjustable.

4. **HIGH PRESSURE GAUGE:** High range gauge which accommodates pressures beyond the capacity of the low pressure gauge: 0 to 5,000 PSI.
5. **FLOW METER:** This meter measures actual oil flow in the operating circuit with a gauge rated at 15 GPM.
6. **OUTLET HOSE:** A hose from the outlet side of the hydraulic tester connects to the hydraulic system circuit.



Figure 45

## Hydraulic Test Fitting Kit

Toro Part Number: **TOR4079**

This kit includes a variety of O-ring Face Seal fittings to enable the connection of test gauges into the system.

The kit includes: tee's, unions, reducers, plugs, caps, and male test fittings.

Toro Test Fitting Kit TOR4079				Union 1 Each Toro Tool Number	
Fitting	Tool Number			No 4 to No 8 No 10 to No 8 No 1 to No 8	
	Size No 4 No 6 No 8 No 10 Tee Tool Number		Size No 10 to No 8 No 12 to No 8 Reducer 1 Each Toro Tool Number		
	Size No 4 No 6 No 8 No 10 Plug 2 Each Toro Tool Number		Size No 4 No 6 No 8 No 10 Test Cap Fitting 2 Each Toro Tool Number		
	Size No 4 No 6 No 8 No 10 Cap 2 Each Toro Tool Number		Size 7/16 - 20 1/2 Pipe thread Test Fitting 2 Each Toro Tool Number		

Figure 46

## Measuring Container

Toro Part Number: **TOR4077**

Use this graduated container for doing hydraulic motor efficiency testing (motors with case drain lines only). Measure efficiency of a hydraulic motor by restricting the outlet flow from the motor and measuring leakage from the case drain line while the motor is pressurized by the hydraulic system.

The table in Figure 48 provides gallons per minute (GPM) conversion for measured milliliter or ounce leakage.



Figure 47

GPM	Milliliters in 15 sec.	Ounces in 15 sec.
.1	95	3.2
.2	189	6.4
.3	284	9.6
.4	378	12.8
.5	473	16.0
.6	568	19.2
.7	662	22.4
.8	756	25.6
.9	852	28.8
1.0	946	32.0

Figure 48

---

## O-Ring Kit

Toro Part Number: **117-2727**

The kit includes O-rings in a variety of sizes for face seal and port seal hydraulic connections. It is recommended that O-rings be replaced whenever a hydraulic connection is loosened.



Figure 49

---

## Wheel Hub Puller

Toro Part Number: **TOR4097**

The wheel hub puller allows safe removal of the wheel hub from the shaft of wheel motors.



Figure 50

---

## Hydraulic Hose Kit

Toro Part Number: **TOR6007**

This kit includes hydraulic fittings and hoses needed to connect high flow hydraulic filter kit (TOR6011) to machine hydraulic traction system components.

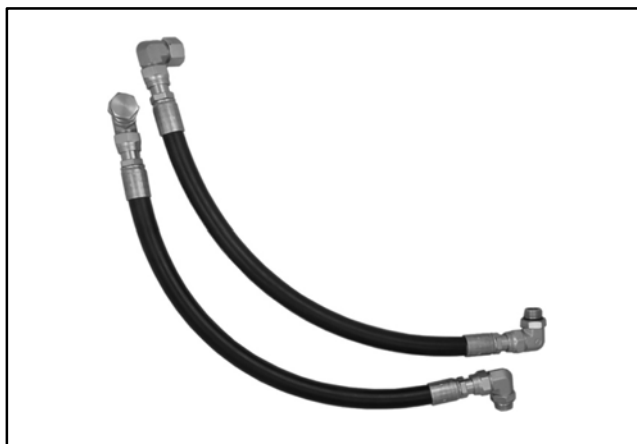

Figure 51

---

## High Flow Hydraulic Filter Kit

Toro Part Number: **TOR6011**

The high flow hydraulic filter kit is designed with large flow (40 GPM/150 LPM) and high pressure (5000 PSI/345 bar) capabilities. This kit provides for bi-directional filtration which prevents filtered debris from being allowed back into the circuit regardless of flow direction.

If a component failure occurs in the closed loop traction circuit, contamination from the failed part will remain in the circuit until removed. When connecting hydraulic test gauges in order to test traction circuit components or after replacing a failed traction circuit component (e.g. piston pump or wheel motor), the high flow hydraulic filter can be installed in the traction circuit. The filter will ensure that contaminants are removed from the closed loop and thus, do not cause additional component damage.

**NOTE:** This kit does not include hydraulic hoses (see Hydraulic Hose Kit TOR6007 above).

**NOTE:** Replacement filter element is Toro part number TOR6012. Filter element cannister tightening torque is **25 ft-lb (34 N-m)**.



Figure 52

# Troubleshooting

The charts that follow contain information to assist in troubleshooting. There may possibly be more than one cause for a machine malfunction.

Refer to the Testing section of this Chapter for precautions and specific test procedures.

Problem	Possible Cause
Hydraulic oil leaks from system.	Fitting(s), hose(s), or tube(s) are loose or damaged. O- ring(s) or seal(s) are missing or damaged.
Hydraulic fluid foams.	Oil level in reservoir is low. Hydraulic system has wrong type of oil. One of the pump suction lines has an air leak. Incompatible hydraulic oils mixed in system. Water in hydraulic system.
Hydraulic system operates hot.	Transmission pressure is high due to load or brakes applied. Oil level in reservoir is low, or inlet filter is loose or clogged. Oil is contaminated or oil viscosity is too light. Oil cooler is damaged or plugged. By- pass relief is stuck open or air flow is obstructed. Hydrostat by- pass valve is open or defective. Charge pressure is low. Wheel motor(s) or cutting unit motor(s) are worn or damaged. Traction pump is worn or damaged.
Neutral is difficult to find, or unit operates in one direction only.	External control linkage is misadjusted, disconnected, binding, or damaged. Traction pump is worn or damaged.
Traction response is sluggish.	Hydrostat by- pass valve is open or worn. Brake is not released. Charge pressure is low. Hydraulic oil is very cold. Traction pump or wheel motor(s) are worn or damaged.
No traction exists in either direction.	Brake is not released. Oil level in reservoir is low. Hydrostat by- pass valve is open. Traction pump drive belt loose or broken. Charge pressure is low. Traction pump or wheel motor(s) are worn or damaged.

Problem	Possible Cause
Wheel motor will not turn.	<p>Brakes are binding.</p> <p>Key on wheel motor shaft is sheared or missing.</p> <p>Internal parts in wheel motor are damaged.</p>
Wheel motor will not hold load in neutral.	<p>Make up fluid from charge pump is not available.</p> <p>Hydrostat ball check valves are damaged.</p>
Cutting unit gear pump (P1) is noisy (cavitation).	<p>Reservoir oil level is low.</p> <p>Suction line is restricted.</p> <p>Suction line has an air leak.</p>
Blades will not turn.	<p>Solenoid valve (R1) is stuck open.</p> <p>An electrical problem exists (See Chapter 5- Electrical System).</p> <p>Gear pump (P1) is damaged.</p>
Blades(s) turn too slowly.	<p>Gear pump (P1) is inefficient (see Testing).</p> <p>Cutting motor has internal leakage or malfunctioning cross- over relief valve (see Testing).</p> <p>Spindle bearing(s) are damaged.</p>
Cutting units will not lift or lift slowly.	<p>Engine speed is too low.</p> <p>Lift cylinder linkage is binding or broken.</p> <p>Lift cylinder bushings are binding.</p> <p>Reservoir oil level is low.</p> <p>Charge pump (P2) pressure or flow is insufficient.</p> <p>Charge pump (P2) is damaged.</p> <p>Implement relief valve (1000 PSI) is stuck open.</p> <p>Lift cylinders leak internally.</p> <p>Steering control valve is defective.</p>
Cutting units raise, but will not stay up.	<p>Lift cylinders leak internally.</p> <p>Check valve within the lift control valve leaks.</p>
Steering Problems.	<p>See Ross Troubleshooting Guide in the Hydraguide™ Hydrostatic Steering System HGF Series Service Procedure or Sauer/Danfoss Steering Unit Type OSPM Service Manual at the end of this chapter.</p>
Turning steering wheel turns machine in the opposite direction.	<p>Hoses to the steering cylinder are reversed.</p>

# Testing

The most effective method for isolating problems in the hydraulic system is by using hydraulic test equipment such as pressure gauges and flow meters in the circuits during various operational checks (See the Special Tools section in this Chapter).

## Before Performing Hydraulic Tests

**IMPORTANT:** All obvious areas such as oil supply, filter, binding linkages, loose fasteners, or improper adjustments must be checked before assuming that a hydraulic component is the source of the problem.

## Precautions for Hydraulic Testing

 <b>CAUTION</b>
Failure to use gauges with recommended pressure (psi) rating as listed in test procedures could result in damage to the gauge and possible personal injury from leaking hot oil.

 <b>CAUTION</b>
All testing should be performed by two (2) people. One person should be in the seat to operate the machine, and the other should read and record test results.

 <b>WARNING</b>
Keep body and hands away from pin hole leaks or nozzles that eject hydraulic fluid under high pressure. Do not use hands to search for leaks; use paper or cardboard. Hydraulic fluid escaping under pressure can have sufficient force to penetrate the skin and cause serious injury. If fluid is injected into the skin, it must be surgically removed within a few hours by a doctor familiar with this type of injury. Gangrene may result from such an injury.

1. Clean machine thoroughly before disconnecting or disassembling any hydraulic components. Always keep in mind the need for cleanliness when working on hydraulic equipment. Contamination will cause excessive wear of components.

2. Put metal caps or plugs on any hydraulic lines left open or exposed during testing or removal of components.

 <b>WARNING</b>
<b>Before disconnecting or performing any work on the hydraulic system, all pressure in the system must be relieved. See Relieving Hydraulic System Pressure in the General Information section.</b>

3. The engine must be in good operating condition. Use a phototac when performing a hydraulic test. Engine speed can affect the accuracy of the tester readings. Check actual speed of the pump when performing flow testing.

4. The inlet and the outlet hoses must be properly connected and not reversed (tester with pressure and flow capabilities) to prevent damage to the hydraulic tester or components.

5. When using tester with pressure and flow capabilities, open load valve completely in the hydraulic tester to minimize the possibility of damaging components.

6. Install fittings finger tight and far enough to make sure that they are not cross-threaded before tightening them with a wrench.

7. Position tester hoses to prevent **rotating** machine parts from contacting and damaging the hoses or tester.

8. Check oil level in the hydraulic tank. After connecting test equipment, make sure tank is full.

9. Check control linkages for improper adjustment, binding, or broken parts.

10. All hydraulic tests should be made with the hydraulic oil at normal operating temperature.

11. If a traction circuit problem exists, consider performing one or more of the following tests: Traction Circuit Working Pressure, Charge Relief Valve Pressure, Piston Pump (P3) Flow & Traction Relief Pressure and/or Wheel Motor Efficiency Tests.

12. If a cutting circuit problem exists, consider performing one or more of the following tests: Cutting Deck Circuit Pressure, Manifold Relief Valve (R1) Pressure, Logic (Counterbalance) Valve (LC1) Pressure, Gear Pump (P1) Flow and/or Deck Motor Efficiency Tests.

13. If a steering or lift circuit problem exists, consider performing one or more of the following tests: Steering and Lift Relief Pressure, Gear Pump (P2) Flow and/or Steering Control Valve Tests.



This page is intentionally blank.

# Traction Circuit Working Pressure Test (Using Pressure Gauge)

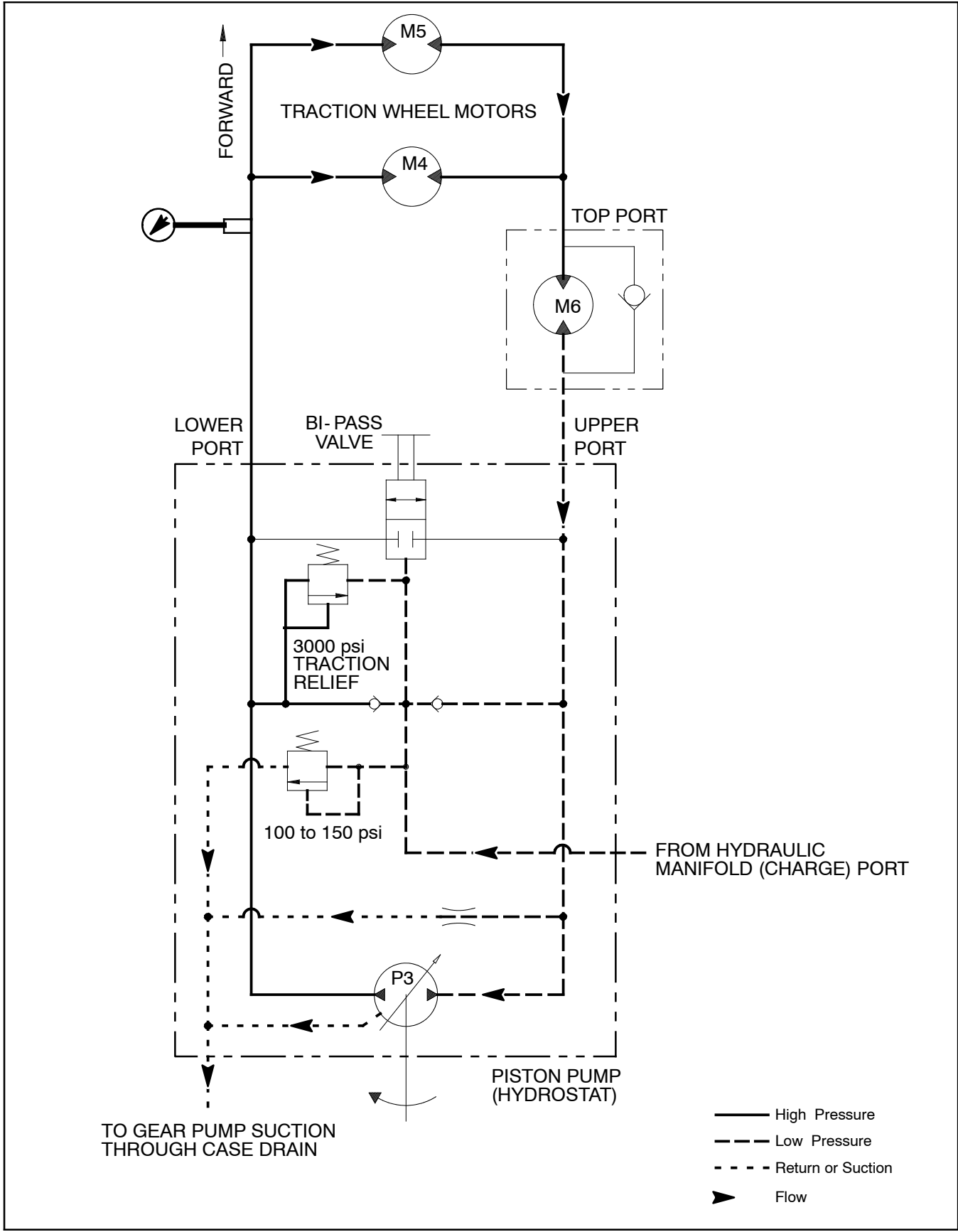

### Procedure for Traction Circuit Working Pressure Test:

1. Make sure hydraulic oil is at normal operating temperature by operating the machine for approximately 10 minutes.
2. Park machine on a level surface with the cutting units lowered and off. Make sure engine is off.
3. Read Precautions for Hydraulic Testing.
4. Make sure that traction pedal is adjusted to the neutral position (see Adjust Traction Drive for Neutral in the Adjustments Section).
5. Remove plug from hydraulic tube connected to front wheel motors (Fig. 53). Connect test gauge with a hydraulic hose attached to the hydraulic tube opening. Make sure hose is long enough so the operator can read gauge while driving the machine.
6. Start engine and move throttle to full speed ( $3050 \pm 50$  RPM).

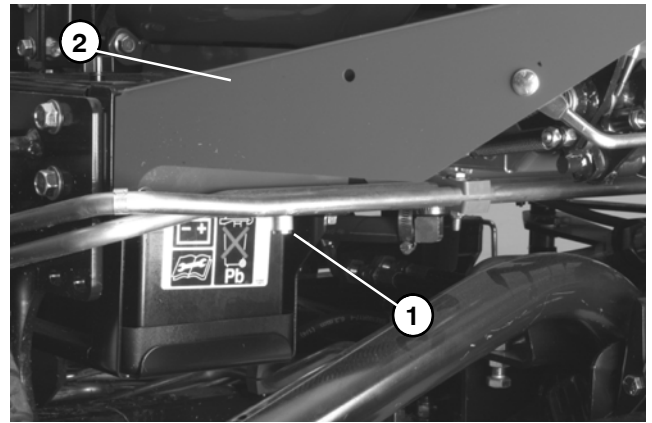

Figure 53

1. Hydraulic tube with plug
2. Floor plate

**CAUTION**

**Do not operate sidewinder while performing test. The test gauge hose may get hit by the sidewinder carrier and rupture, and cause personal injury.**

7. Drive machine in the **forward** direction. Observe test gauge:
  - A. Pressure while transporting the machine over a flat, level surface should be about **500 PSI**.
  - B. Pressure driving the machine up a steep hill should be about **3300 PSI** but can reach relief settings (3500 PSI).
  - C. Pressure while mowing should range between **1000 to 2000 PSI** and will vary with terrain conditions.
8. Release traction pedal and turn off machine.
9. Disconnect test gauge and hose from the hydraulic tube. Install plug into tube opening.
10. If specification is not met, the hydrostat needs to be repaired or replaced as necessary.

**Piston Pump (P3) Flow and Traction Relief Pressure Test (Using Tester with Pressure Gauges and Flow Meter)**

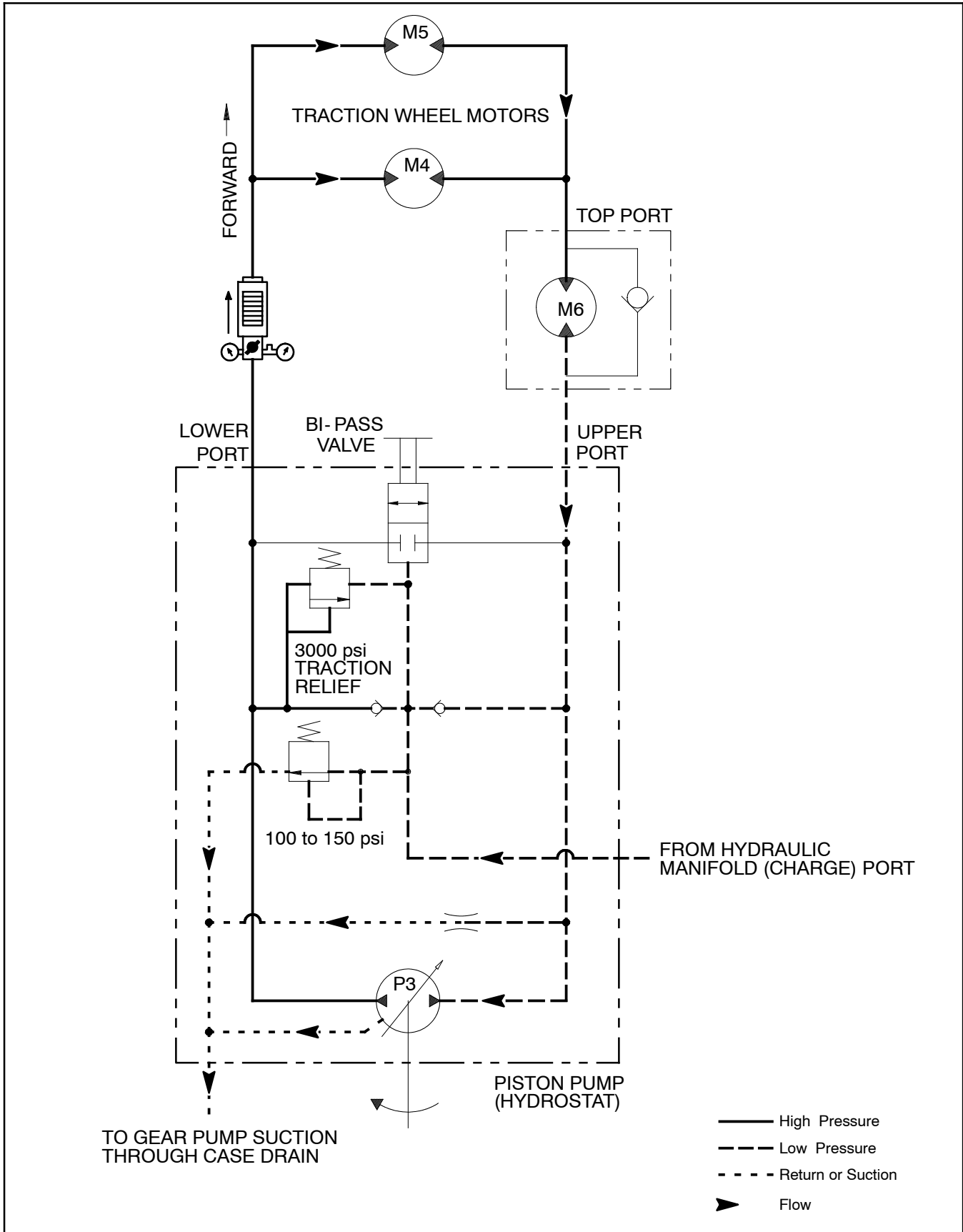

### **Procedure for Piston Pump (P3) Flow and Traction Relief Pressure Test:**

1. Make sure hydraulic oil is at normal operating temperature by operating the machine for approximately 10 minutes.
2. Park machine on a level surface with the cutting units lowered and off. Make sure engine is off.
3. Read Precautions for Hydraulic Testing.
4. Make sure that traction pedal is adjusted to the neutral position (see Adjust Traction Drive for Neutral in the Adjustments Section).



5. Block up one front traction wheel and the rear wheel off the floor to allow flow through the traction circuit; disconnect brake linkage to the raised front wheel (see Wheels and Brakes - Chapter 7).
6. Chock remaining front wheel to prevent movement of the machine.
7. Attach a heavy chain to the rear of the machine frame and something immovable in the shop.
8. Make sure parking brake is on.
9. Disconnect hose from the lower hydraulic fitting on the engine side of the hydrostat (Fig. 54).
10. Install tester in series with the pump and the disconnected hose. Make sure the tester flow control valve is fully open.
11. Start engine and move throttle to full speed ( $3050 \pm 50$  RPM).



12. Slowly push traction pedal fully to **forward** position.

13. Verify traction relief valve setting by closing flow control valve on tester. System pressure should be **3500 PSI** as the relief valve lifts. If pressure can not be met or is exceeded with traction pedal fully depressed, release traction pedal and open flow control valve fully.

14. If specification is not met consider the following:

- A. The traction belt may be worn and slipping (see Replace Traction Belt).
- B. The relief valve leaks or is faulty and needs replacement.
- C. The hydrostat needs to be repaired or replaced as necessary.

15. If the traction relief valve tests out properly, verify pump flow as follows:

- A. Apply traction pedal until pressure gauge reads **1000 PSI**. Verify with a phototac that the **pump speed** is **2350 RPM** (engine speed approximately 2450 RPM).
- B. Observe flow gauge. **TESTER READING** should be approximately **12.5 GPM**.

16. Release traction pedal and turn off machine.

**Note:** If pressure is good under no load, but drops below specification when under traction load, the piston pump and/or wheel motor(s) should be suspected of wear. When a pump and/or motor is worn or damaged, the charge pump is not able to keep up with internal leakage in the traction circuit (See Test #3).

17. If specifications are not met, the hydrostat needs to be repaired or replaced as necessary.

18. Disconnect tester from hydraulic fitting and hose. Reconnect hose to pump connection.

19. Reconnect brake linkage to wheel (see Wheels and Brakes - Chapter 7).

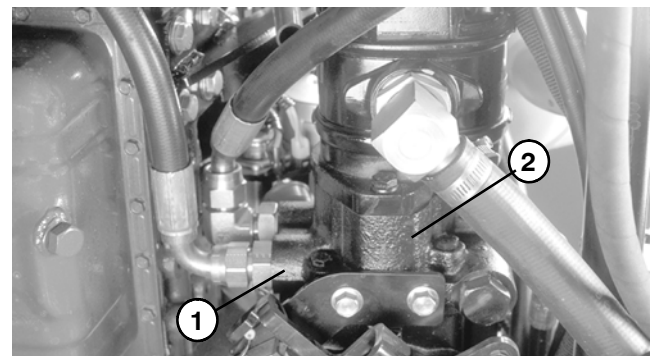
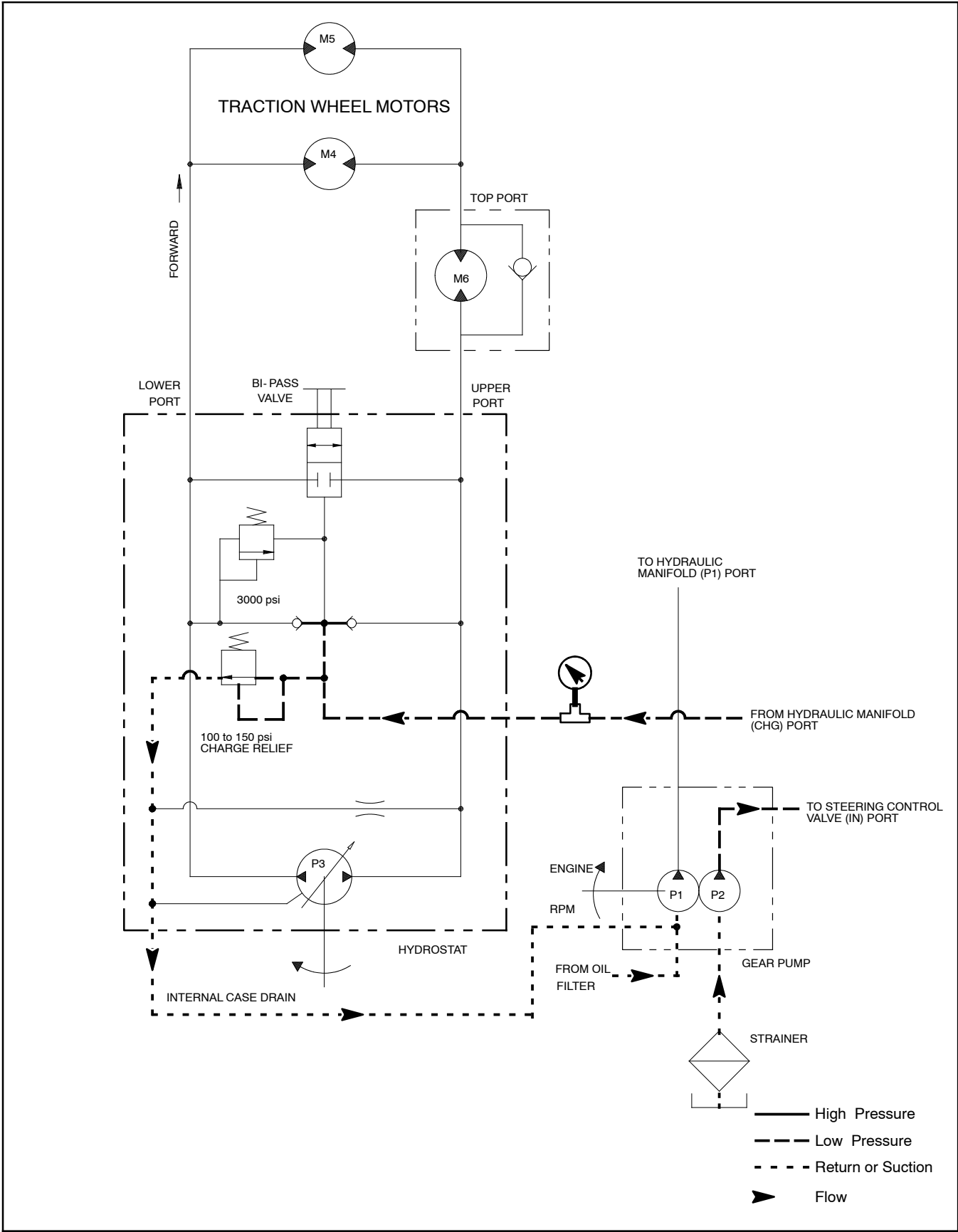

Figure 54

1. Lower hydraulic fitting
2. Piston pump

# Charge Relief Valve Pressure Test



### Procedure for Charge Relief Valve Pressure Test:

1. Make sure hydraulic oil is at normal operating temperature by operating the machine for approximately 10 minutes.
2. Park machine on a level surface with the cutting units lowered and off. Make sure engine is off and the parking brake is engaged.
3. Read Precautions for Hydraulic Testing.
4. Disconnect hose to the rear 90° hydraulic fitting on the piston pump coming from the hydraulic manifold port (CHG). Connect T-connector and pressure gauge to the fitting and hose connection.
5. Make sure that traction pedal is in neutral and the parking brake is engaged.
6. Start engine and operate engine at full speed (3050 ± 50 RPM).
7. Pressure gauge should read from **100 to 150 PSI**.
8. If charge relief pressure specification is not met, consider the following:
  - A. The piston pump charge relief valve is faulty. Repair or replace the piston pump charge relief valve (see Piston Pump Service in the Service and Repairs section).
  - B. Gear pump (P2) is faulty (steering and lift circuits are also affected).
9. A dynamic charge pressure test can be performed as follows:
  - A. With T-connector and pressure gauge still connected, sit in the operator seat and press the traction pedal to forward.
  - B. While machine is moving, monitor the charge pressure reading on the pressure gauge.
  - C. The charge pressure should drop no more than 15% from initial test reading (Step 7 above). A pressure drop of more than 15% indicates a traction circuit leak (e.g. a worn or damaged piston pump and/or wheel motor).
10. Shut off engine.
11. Disconnect gauge and T-connection from the 90° hydraulic fitting and hose connection. Reconnect hose to the hydrostat.

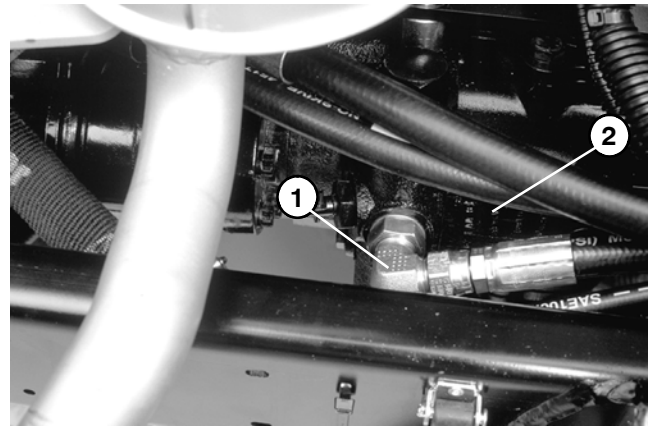
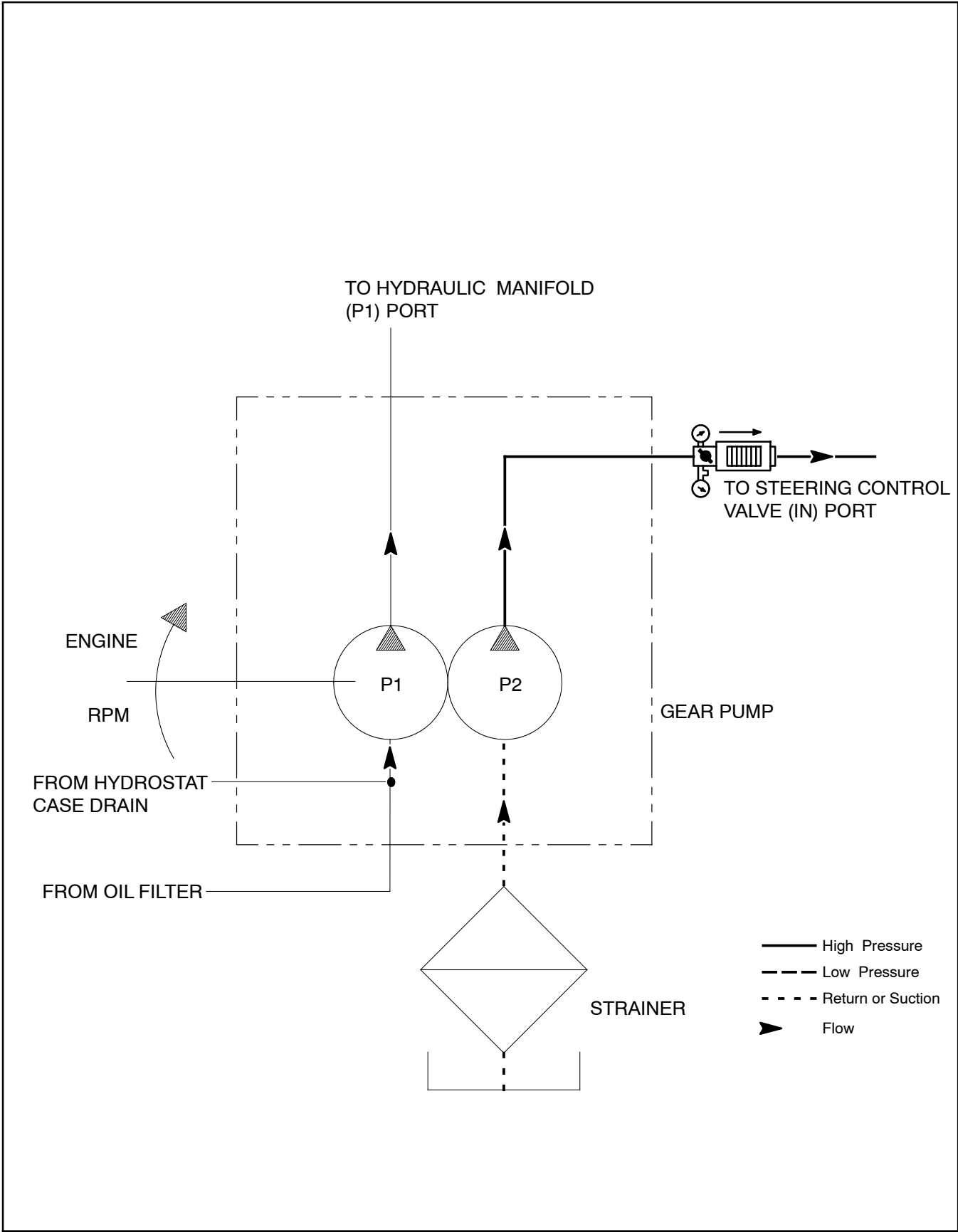

Figure 55

1. 90° hydraulic fitting
2. Piston pump

**Gear Pump (P2) Flow Test (Using Tester with Pressure Gauges and Flow Meter)**





### Procedure for Gear Pump (P2) Flow Test:

1. Make sure hydraulic oil is at normal operating temperature by operating the machine for approximately 10 minutes.
2. Park machine on a level surface with the cutting units lowered and off. Make sure engine is off and the parking brake is engaged.
3. Read Precautions for Hydraulic Testing.
4. Disconnect hose connection on the gear pump (P2) leading to the steering control valve (Fig. 56).
5. Install tester in series with gear pump and the disconnected hose leading to the steering control valve.
6. Make sure the flow control valve on the tester is fully open.
7. Start engine and move throttle to full speed ( $3050 \pm 50$  RPM). **Do not engage the cutting units.**

**IMPORTANT:** In this test, the hydraulic tester is positioned before the manifold relief valve. Pump damage can occur if the oil flow is fully restricted by fully closing the tester flow control valve. Do not close tester valve fully when performing test.

8. Watch pressure gauge carefully while slowly closing the flow control valve until **800 PSI** is obtained. Verify with a phototac that the **pump speed** is **3100 RPM** while maintaining 800 PSI.

9. Flow indication should be **3.6 GPM** minimum.

10. Shut off engine.

**NOTE:** If necessary, Steering and Lift Relief Pressure Test can be conducted with tester as placed for this test.

11. If flow was less than **3.6 GPM** or a pressure of **800 PSI** cannot be obtained, check for restriction in the pump intake line. If line is not restricted, remove gear pump (P2) and repair or replace as necessary.

12. Disconnect tester from gear pump fitting and hose. Reconnect hose to the pump.

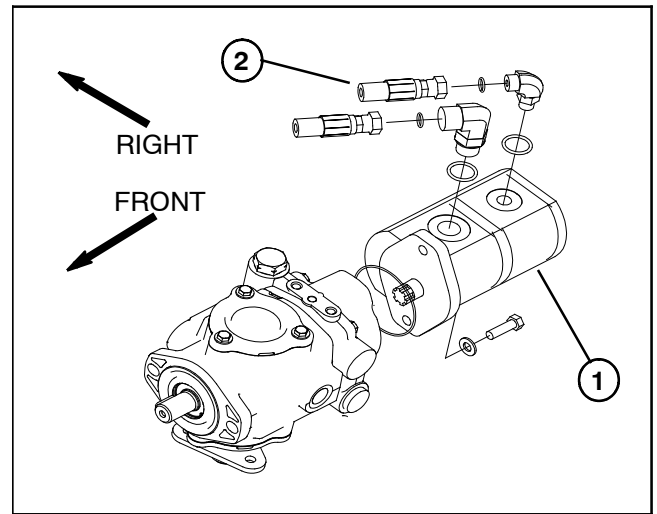

Figure 56

1. Gear pump (P2)
2. To steering control valve

## Wheel Motor Efficiency Test (Using Tester with Pressure Gauges and Flow Meter)

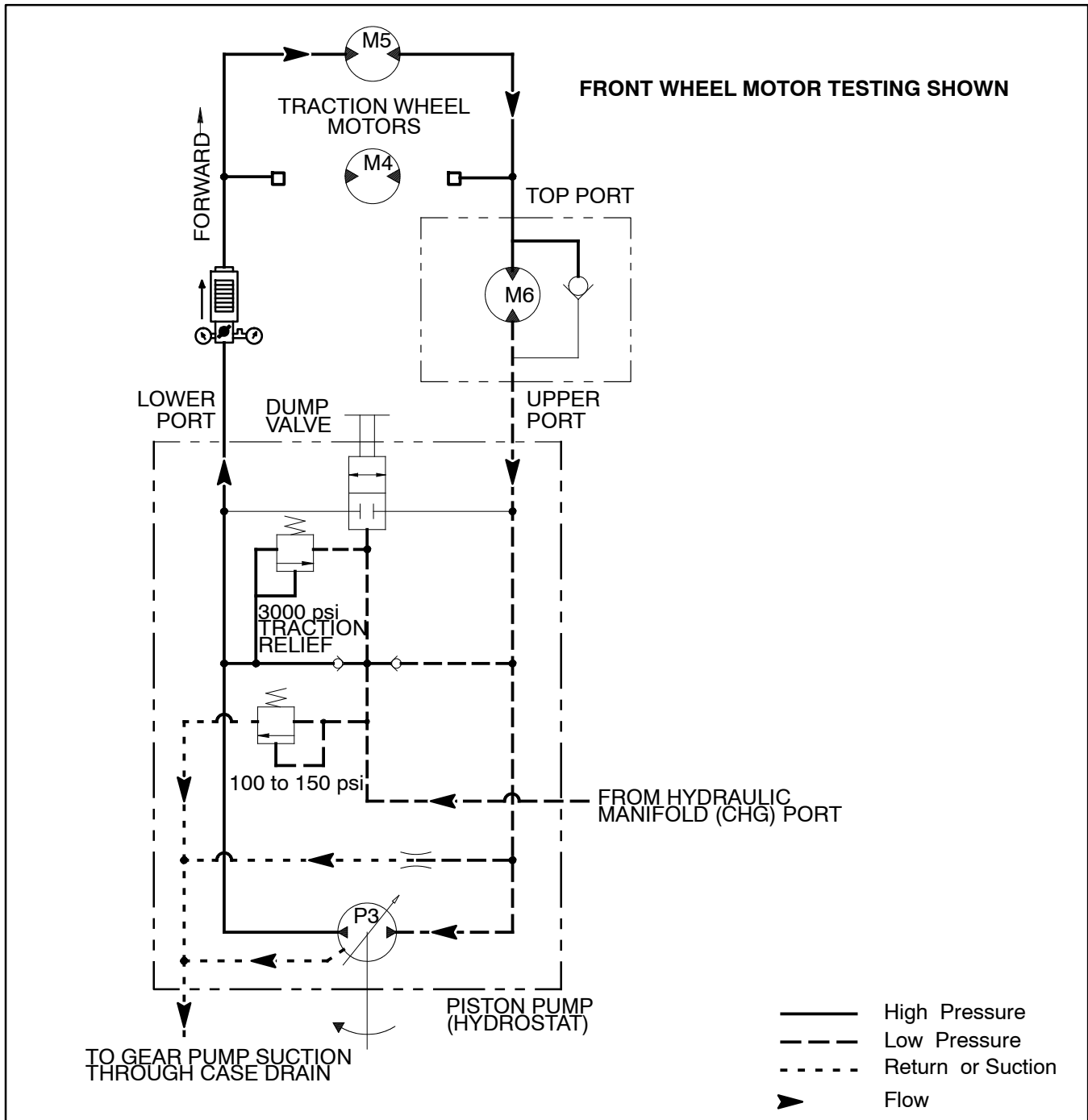

Figure 57

**NOTE:** Over a period of time, a wheel motor can wear internally. A worn motor may by-pass oil to its case drain causing the motor to be less efficient. Eventually, enough oil loss will cause the wheel motor to stall under heavy load conditions. Continued operation with a worn, inefficient motor can generate excessive heat, cause damage to seals and other components in the hydraulic system, and affect overall machine performance.

### Procedure for Wheel Motor Efficiency Test:

1. Make sure hydraulic oil is at normal operating temperature by operating the machine for approximately 10 minutes. Make sure the hydraulic tank is full.
2. Park machine on a level surface with the cutting units lowered and off. Make sure engine is off and the parking brake is engaged.
3. Read Precautions for Hydraulic Testing.
4. Make sure that traction pedal is adjusted to the neutral position (see Adjust Traction Drive for Neutral in the Adjustments Section).
5. Attach a heavy chain to the rear of the machine frame and an immovable object to prevent the machine from moving during testing.

 <b>WARNING</b>
<b>The rear wheel will be off the ground during front wheel motor testing. Make sure machine is supported so it will not move and accidentally fall to prevent injuring anyone under machine.</b>

6. Block up the rear wheel off the ground to allow flow through the traction circuit.
  7. Chock front wheel being tested to prevent rotation of the wheel. Make sure parking brake is on.
  8. Disconnect hydraulic lines from front wheel motor that is **not** being tested. Cap disconnected hydraulic lines and plug ports in wheel motor to prevent contamination.
  9. Disconnect hose from the lower hydraulic fitting on the bottom of the hydrostat (Fig. 58).
- NOTE:** An alternate testing location would be at the hydraulic hose connection to the hydraulic tube under the left floor plate.
10. Install flow tester in series with the pump and the disconnected hose. Make sure the tester flow control valve is fully open.
  11. Start engine and move throttle to full speed (**3050 ± 50 RPM**).

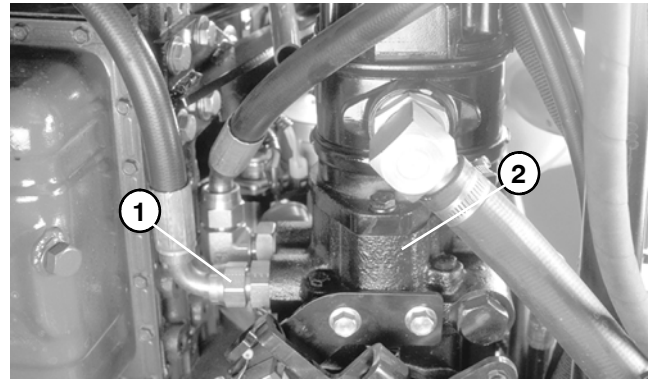

Figure 58

1. Lower hydraulic fitting
2. Piston pump

 <b>CAUTION</b>
<b>Use extreme caution when performing test. The front tire on the ground will be trying to move the machine forward.</b>

12. Slowly push traction pedal in **forward** direction until 1000 PSI is displayed on the pressure gauge.
13. Motor internal leakage will be shown on flow meter in GPM. Flow should be **less than 1.5 GPM** for the tested wheel motor.
14. If specifications are not met, the tested wheel motor needs to be repaired or replaced as necessary.
15. If remaining front wheel motor requires testing, complete steps 5 to 14 for the remaining motor.
16. If rear wheel motor requires testing:
  - A. Both front wheel motors should have hydraulic lines connected. Block up both front wheels off the ground. Release parking brake so front wheels can turn.
  - B. Attach a heavy chain to the rear of the machine frame and an immovable object to prevent the machine from moving during testing.
  - C. Position rear wheel on the ground and chock rear wheel to prevent it from turning.
  - D. Complete steps 9 to 13.
  - E. If specifications are not met, check the relief valve in the rear wheel motor for damage. If relief valve is not damaged, wheel motor needs to be repaired or replaced.
17. Disconnect tester from hydraulic fitting and hose. Reconnect hose to pump connection.

# Cutting Deck Circuit Pressure Test

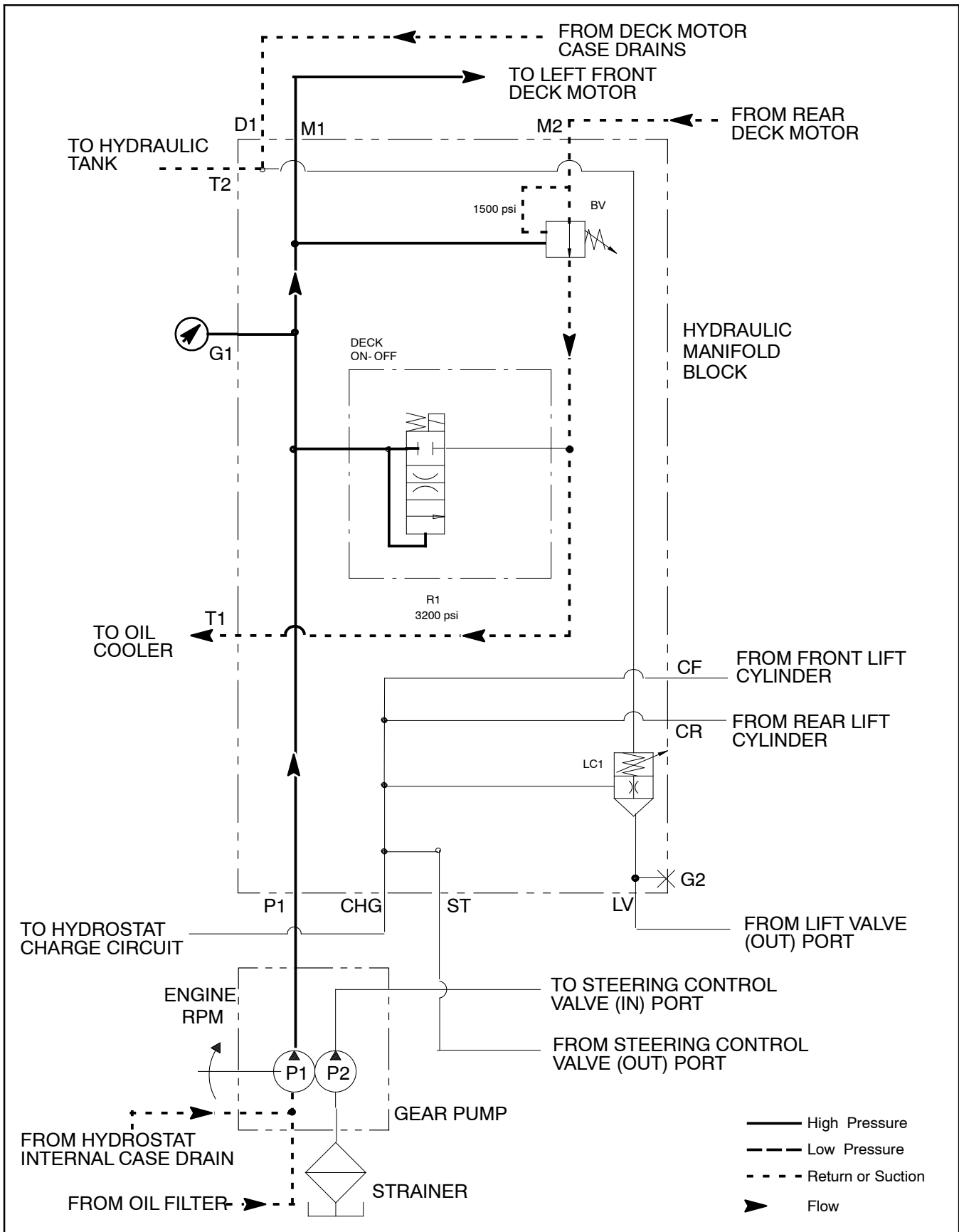

**Procedure for Cutting Deck Circuit Pressure Test:**

1. Make sure hydraulic oil is at normal operating temperature by operating the machine for approximately 10 minutes.
2. Park machine on a level surface with the cutting units lowered and off. Make sure engine is off and the parking brake is engaged.
3. Read Precautions for Hydraulic Testing.
4. Remove plug from hydraulic manifold port (G1).
5. Install test gauge with hydraulic hose attached to the manifold port (G1).

	<b>CAUTION</b>
<b>Keep away from decks during test to prevent personal injury from the cutting blades.</b>	

6. Start engine and move throttle to full speed ( $3050 \pm 50$  RPM). Engage the cutting units.
7. Watch pressure gauge carefully while mowing with the machine.
8. Cutting circuit pressure should be from **1000 to 1500 PSI** and will vary depending on mowing conditions.
9. Disengage cutting units. Shut off engine.
10. Disconnect test gauge with hose from manifold block. Reconnect plug to the hydraulic manifold port (G1).

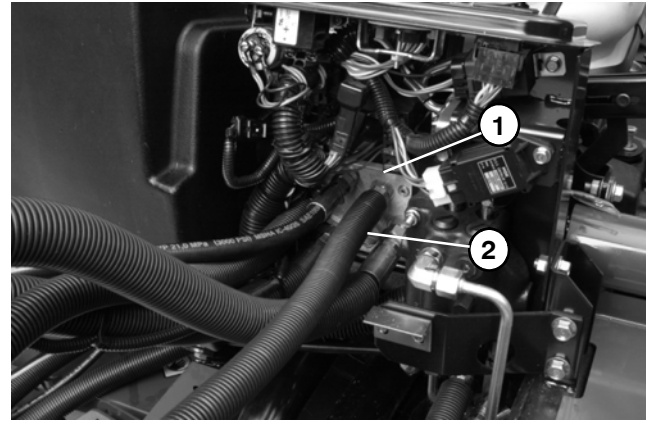

Figure 59

1. Hydraulic manifold
2. Manifold port (G1)

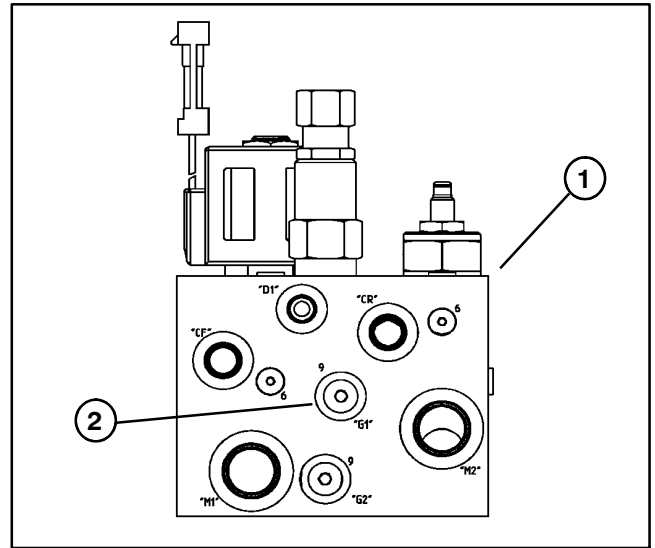
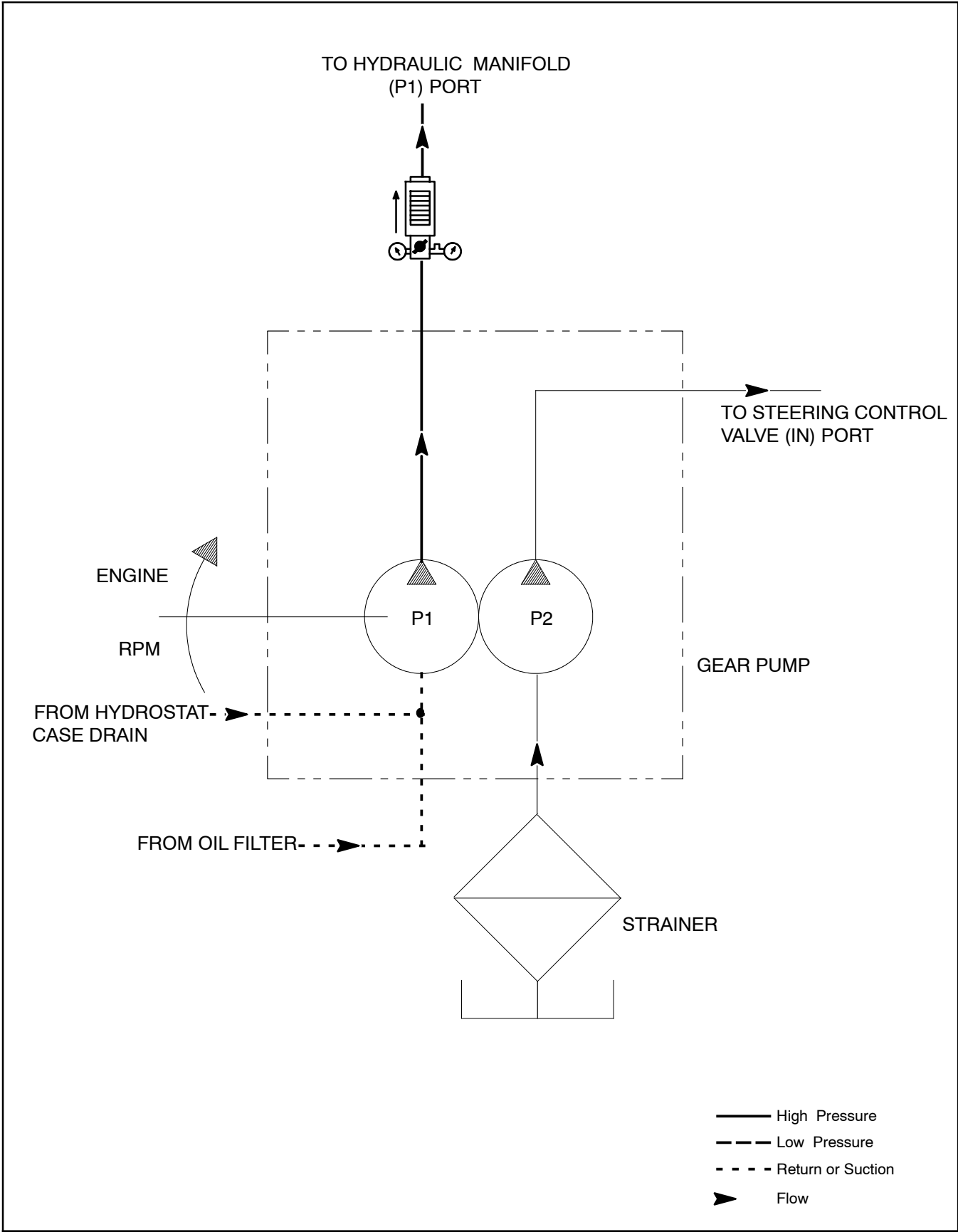

Figure 60

1. Hydraulic manifold
2. Manifold port (G1)

**Hydraulic System**

**Gear Pump (P1) Flow Test (Using Tester with Pressure Gauges and Flow Meter)**



### Procedure for Gear Pump (P1) Flow Test:

**Note:** Over a period of time, the gears and wear plates in the pump can wear. A worn pump will by pass oil and make the pump less efficient. Eventually, enough oil loss will occur to cause the cutting unit motors to stall under heavy cutting conditions. Continued operation with a worn, inefficient pump can generate excessive heat and cause damage to the seals and other components in the hydraulic system.

1. Make sure hydraulic oil is at normal operating temperature by operating the machine for approximately 10 minutes.
2. Park machine on a level surface with the cutting units lowered and off. Make sure engine is off and the parking brake is engaged.
3. Read Precautions for Hydraulic Testing.
4. Disconnect hose connection on the gear pump (P1) leading to port (P1) on the hydraulic manifold (Fig. 61).
5. Install tester in series with the gear pump and the disconnected hose leading to port (P1) on the hydraulic manifold.
6. Make sure the flow control valve on the tester is fully open.
7. Start engine and move throttle to full speed ( $3050 \pm 50$  RPM). **Do not engage the cutting units.**

**IMPORTANT:** In this test, the hydraulic tester is positioned before the manifold relief valve. Pump damage can occur if the oil flow is fully restricted by fully closing the tester flow control valve. Do not close tester valve fully when performing test.

8. Watch pressure gauge carefully while slowly closing the flow control valve until **2000 PSI** is obtained. **Do not close tester load valve fully.** Verify with a phototac that the **pump speed** is **3100 RPM** while maintaining 2000 PSI.
9. Flow indication should be **11.8 GPM** minimum.
10. Shut off engine.
11. Disconnect tester from gear pump fitting and hose. Reconnect hose to the pump.
12. If flow was less than **11.8 GPM** or a pressure of **2000 PSI** cannot be obtained, check for restriction in the pump intake line. If line is not restricted, remove gear pump (P1) and repair or replace as necessary.

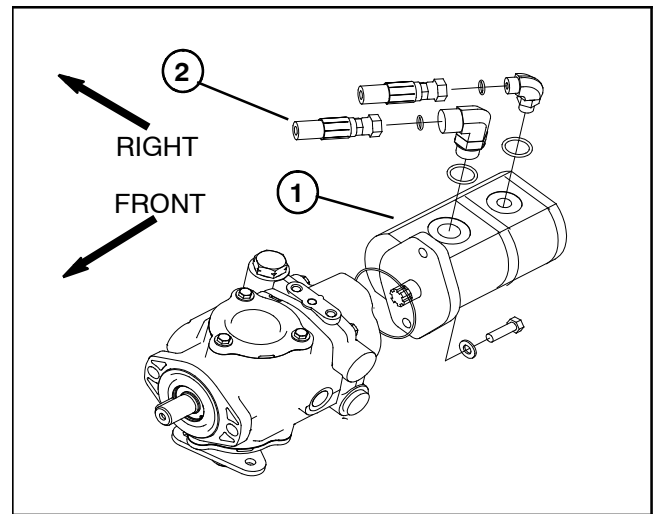
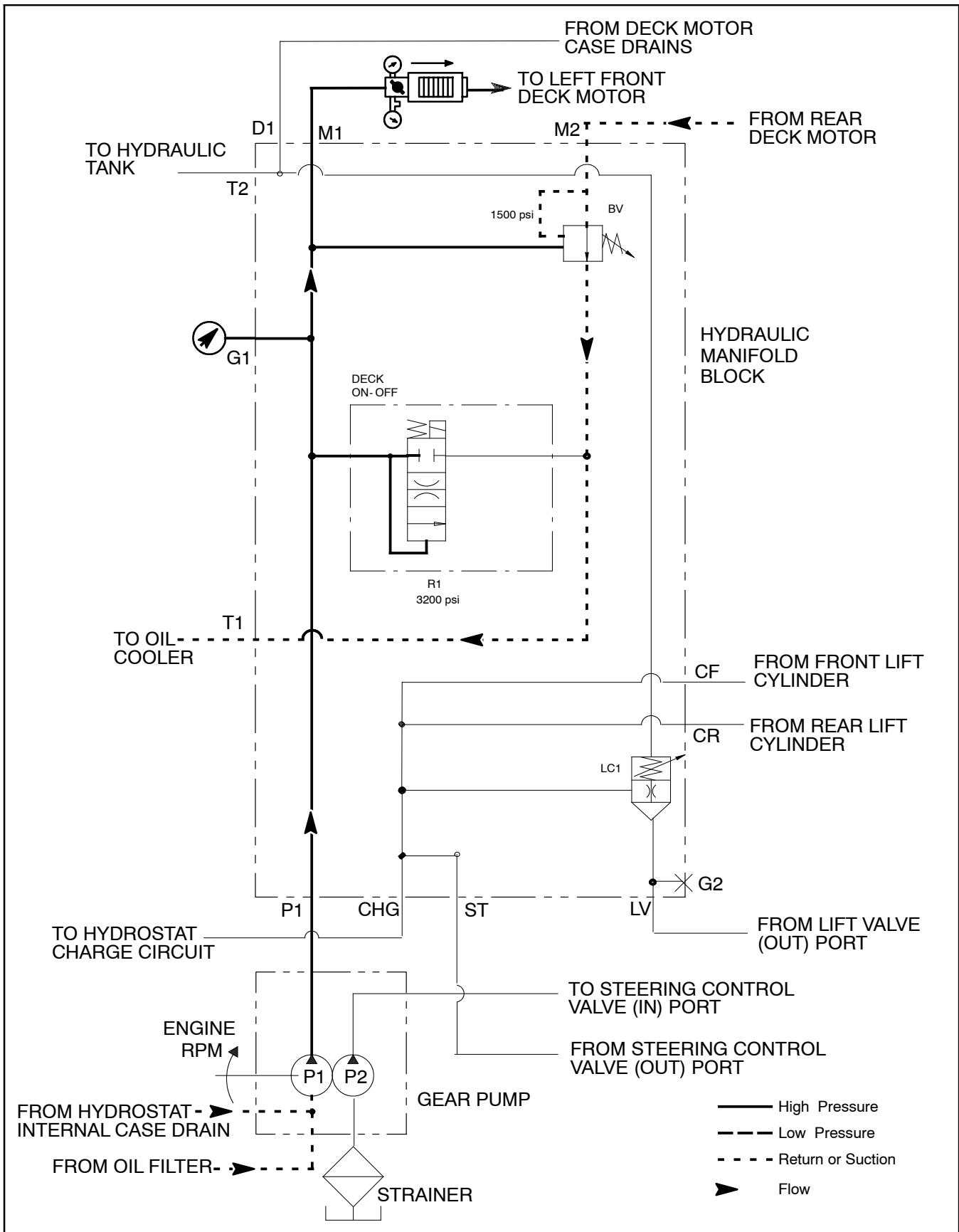

Figure 61

1. Gear pump (P1)

2. To hydraulic manifold

# Manifold Relief Valve (R1) Pressure Test





**Procedure for Manifold Relief Valve (R1) Pressure Test:**

1. Make sure hydraulic oil is at normal operating temperature by operating the machine for approximately 10 minutes.
2. Park machine on a level surface with the cutting units lowered and off. Make sure engine is off and the parking brake is engaged.
3. Read Precautions for Hydraulic Testing.
4. Disconnect hose connection from hydraulic fitting on manifold port (M1) (Figure 62).

**Note:** An alternative to using manifold port (M1) would be to disconnect the inlet hydraulic hose to the front, left deck motor. The motor inlet is opposite from the relief valve on the motor (Figure 64).

5. Install tester in series with the hose and hydraulic fitting. Make sure the flow control valve on tester is fully open.



CAUTION

---

Keep away from decks during test to prevent personal injury from the cutting blades.

6. Start engine and move throttle to full speed (3050 ± 50 RPM). Engage the cutting units.
7. Watch pressure gauge carefully while slowly closing the flow control valve to fully closed.
8. System pressure should be from **3350 to 3600 PSI** as the relief valve lifts.
  - A. If specification is **not** met, shut off engine and clean or replace SRV valve (R1). Return to step 5.
  - B. If this specification is met, proceed to step 9.
9. Disengage cutting units. Shut off engine.
10. Disconnect tester from manifold and hose. Reconnect hydraulic hose that was disconnected for test procedure.

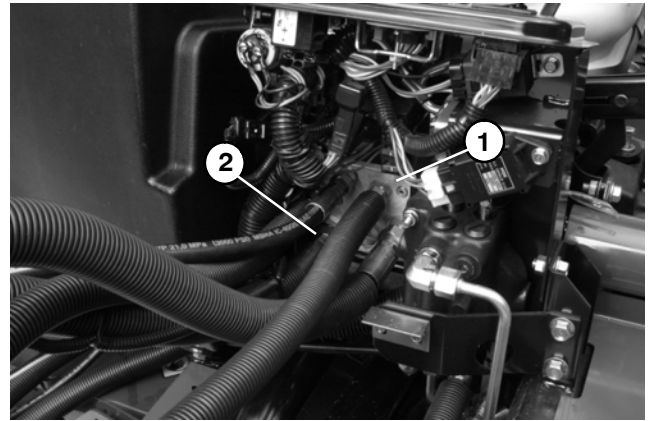

Figure 62

1. Hydraulic manifold      2. Manifold port (M1)

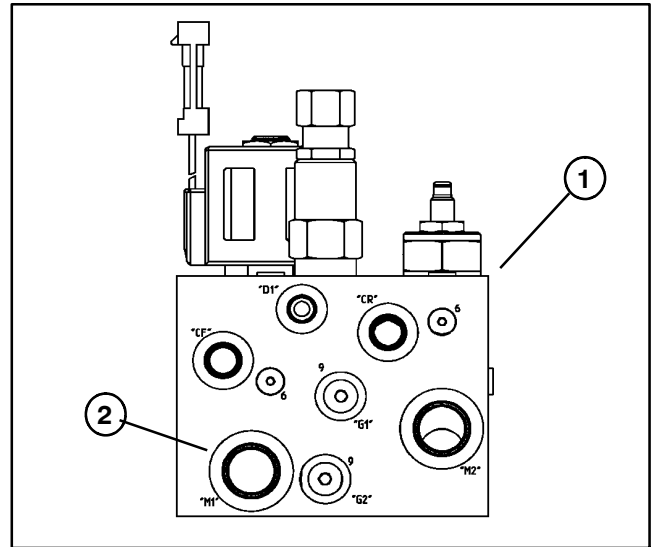

Figure 63

1. Hydraulic manifold      2. Manifold port (M1)

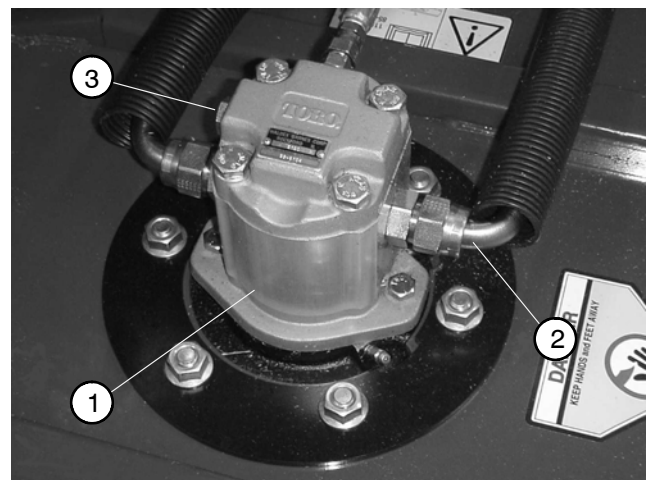
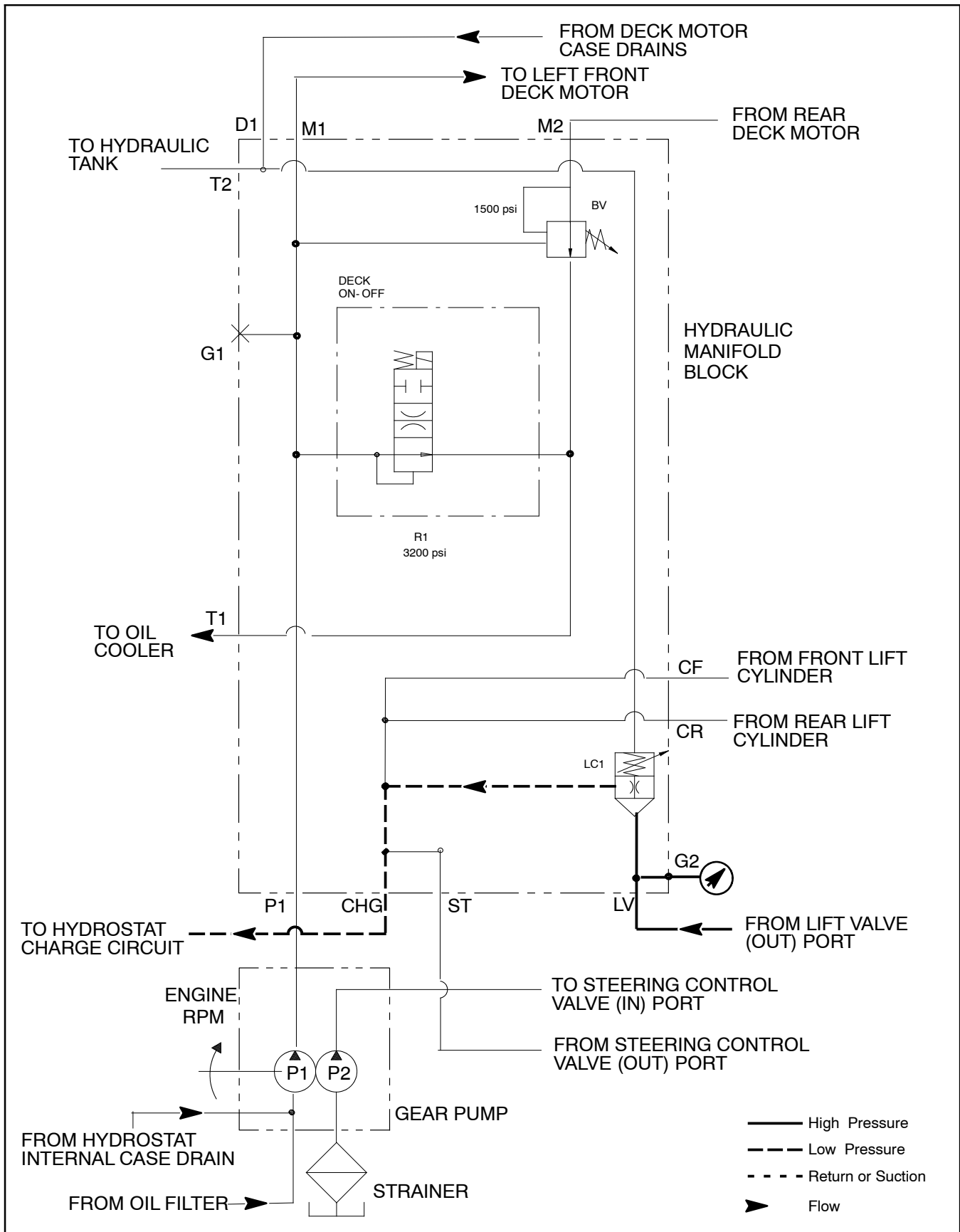

Figure 64

1. Hydraulic deck motor      3. Relief valve  
2. Inlet hose

# Logic (Counterbalance) Valve (LC1) Pressure Test



**Procedure for Logic (Counterbalance) Valve (LC1) Pressure Test:**

**NOTE:** If the counterbalance system is functioning, the machine should normally settle slightly when the engine is started.

1. Make sure hydraulic oil is at normal operating temperature by operating the machine for approximately 10 minutes.
2. Park machine on a level surface with the cutting units lowered and off. Make sure engine is off and the parking brake is engaged.
3. Read Precautions for Hydraulic Testing.
4. Remove plug from hydraulic manifold port (G2) (Fig. 65 and 66).
5. Install test gauge with hydraulic hose attached to port (G2).

	<b>CAUTION</b>
<b>Keep away from decks during test to prevent personal injury from the cutting blades.</b>	

6. Start engine and move throttle to full speed (3050 ± 50 RPM). **Do not engage or raise the cutting units.**
7. The standard counterbalance pressure should be **250 PSI** with a range of 180 to 300 psi. Adjustment of the Logic valve (LC1) can be performed as follows:

**Note:** Do not remove the Logic valve from the hydraulic manifold for adjustment.

- A. Remove hex cap from logic valve (Fig. 67).
- B. Loosen locknut.
- C. To **increase** pressure setting, turn the adjustment shaft on the valve in a clockwise direction. A 1/8 turn on the shaft will make a measurable change in counterbalance pressure.
- D. To **decrease** pressure setting, turn the adjustment shaft on the valve in a counterclockwise direction. A 1/8 turn on the shaft will make a measurable change in counterbalance pressure.
- E. Tighten locknut. Check counterbalance pressure and readjust as needed.
- F. Replace hex cap to Logic valve (LC1).

8. Lower cutting units. Shut off engine.
9. Disconnect test gauge with hose from manifold block. Reconnect plug to the hydraulic manifold port (G2).

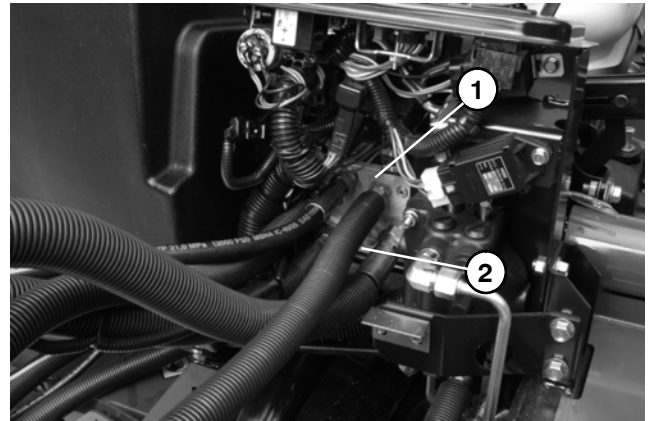

Figure 65

1. Hydraulic manifold      2. Manifold port (G2)

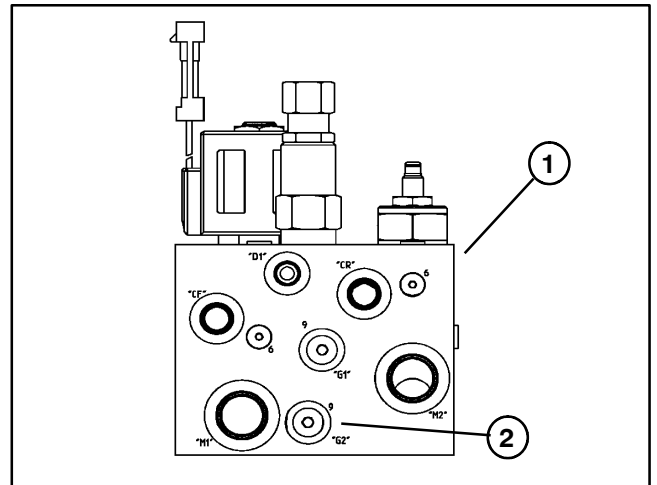

Figure 66

1. Hydraulic manifold      2. Manifold port (G2)

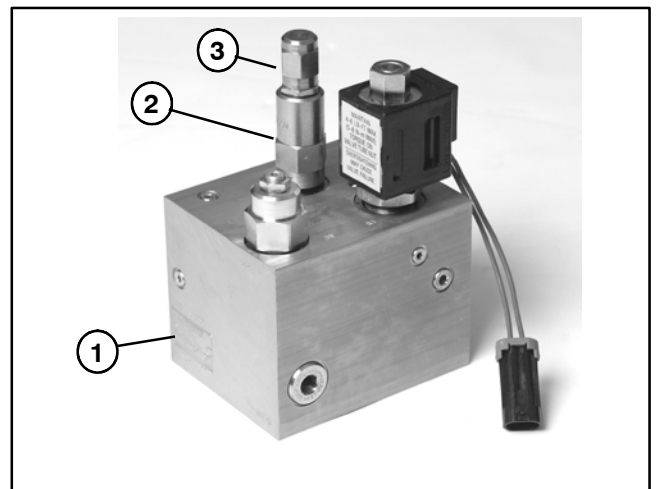
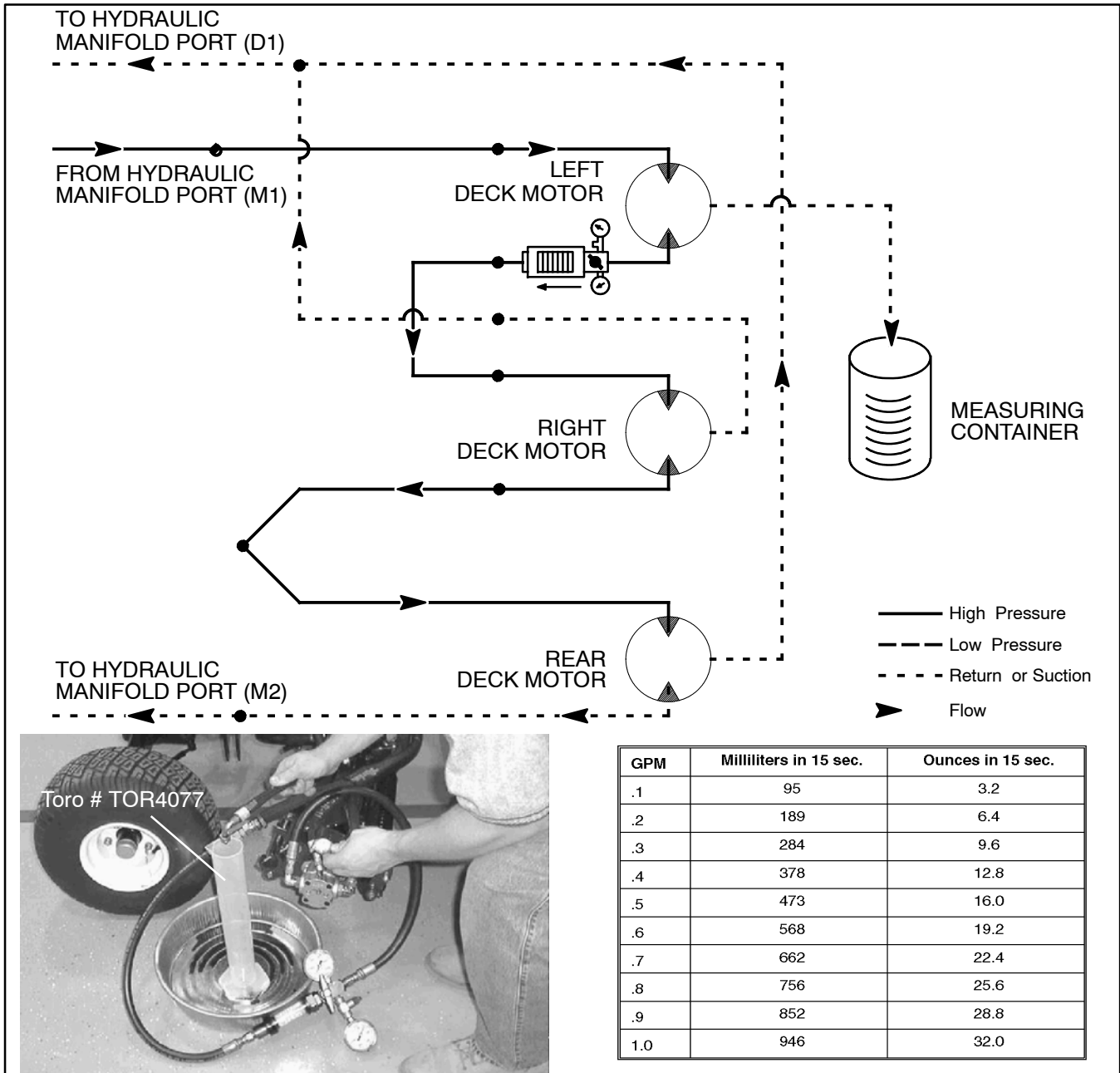

Figure 67

1. Manifold assembly      3. Hex cap  
2. Logic valve (LC1)

Hydraulic System

# Deck Motor Efficiency - Case Drain Test (Using Tester with Pressure Gauges and Flow Meter)



**Note:** Over a period of time, a deck motor can wear internally. A worn motor may by-pass oil to its case drain causing the motor to be less efficient. Eventually, enough oil loss will cause the deck motor to stall under heavy cutting conditions. Continued operation with a worn, inefficient motor can generate excessive heat, cause damage to seals and other components in the hydraulic system, and affect quality of cut.

**Note:** One method to identify a possibly bad deck motor is to have another person observe the machine while mowing in dense turf. A bad motor will run slower, produce fewer clippings, and could cause a different appearance in the turf.

**Procedure for Deck Motor Efficiency - Case Drain Test:**

1. Make sure hydraulic oil is at normal operating temperature by operating the machine for approximately 10 minutes. Make sure the hydraulic tank is full.
2. Remove blades from all cutting decks. Lower the cutting units.
3. Park the machine on a level surface with the cutting units raised and off. Make sure engine is off and the parking brake is engaged.
4. Read Precautions for Hydraulic Testing.

**Note:** The deck motors are connected in series. To isolate a faulty motor, you may have to test all three motors in the circuit by starting with the upstream motor first.

5. For the suspected bad deck motor, disconnect return hose from the motor. **Note:** the return hose is on the motor side that includes the relief valve (Fig. 68).

6. Install hydraulic tester (pressure and flow) in series with the motor and the disconnected return hose. Make sure the tester flow control valve is fully open.

7. Disconnect hose from deck motor case drain at the bulkhead T-fitting (Fig. 69). Plug the T-fitting. Place open end of disconnected case drain hose into a drain pan.

8. One person should sit on the seat and operate the machine while another person reads the tester and measures deck motor case drain leakage. Make sure traction pedal is in **NEUTRAL**. Start engine and move the throttle to full speed (3050 ± 50 RPM).



**CAUTION**

**Keep away from decks during test to prevent personal injury from rotating parts.**

9. Engage decks by positioning the PTO switch to the **ENGAGE** position. While watching hydraulic tester pressure gauge, slowly close flow control valve until a pressure of **1200 PSI** is obtained.

10. After achieving **1200 PSI**, place disconnected motor case drain hose into a container graduated in ounces or milliliters (e.g. Toro #TOR4077) and collect hydraulic fluid for **15 seconds**. After **15 seconds**, remove hose end from container.

11. Stop cutting units by positioning the PTO switch to the **DISENGAGE** position. Stop engine.

12. Identify amount of oil collected in the container. Record test results.

13. If flow was greater than **22.4 ounces (662 milliliters)**, repair or replace the tested deck motor.

14. Relieve hydraulic system pressure (See Relieving Hydraulic System Pressure in the General Information section). Disconnect tester from motor and hose. Reconnect hydraulic hoses.

15. Repeat test with other deck motors as needed.

16. Install cutting blades after testing is completed (see Cutting Unit Operator's Manual).

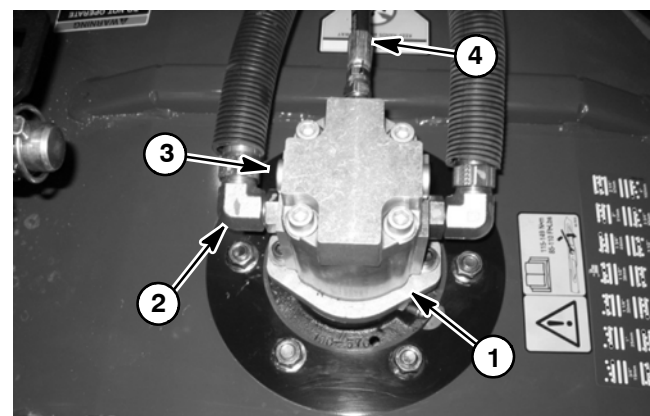

Figure 68

- |                |                    |
|----------------|--------------------|
| 1. Deck motor  | 3. Relief valve    |
| 2. Return line | 4. Case drain hose |

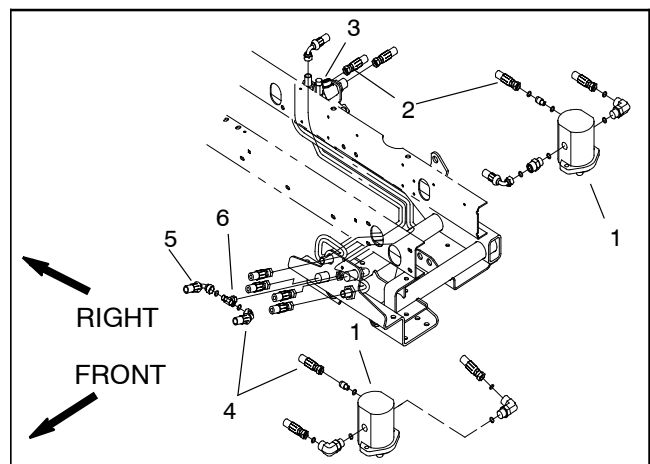
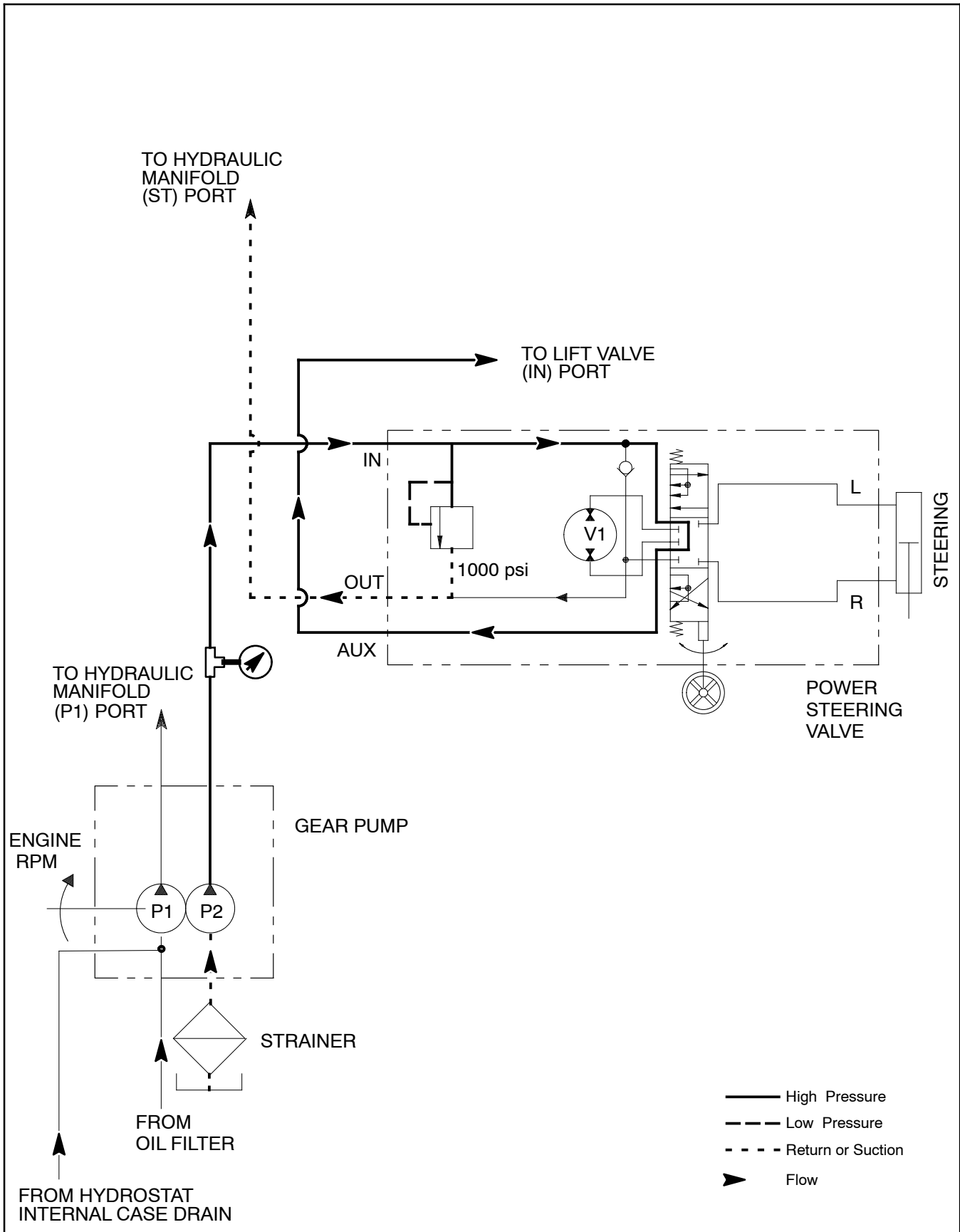

Figure 69

- |                         |                        |
|-------------------------|------------------------|
| 1. Deck motor           | 4. Front LH case drain |
| 2. Rear case drain hose | 5. Front RH case drain |
| 3. Rear T-fitting       | 6. Front T-fitting     |

# Lift and Steering Control Valve Relief Pressure Test



**Procedure for Lift and Steering Control Valve Relief Pressure Test:**

1. Make sure hydraulic oil is at normal operating temperature by operating the machine for approximately 10 minutes.
2. Park machine on a level surface with the cutting units lowered and off. Make sure engine is off and the parking brake is engaged.
3. Read Precautions for Hydraulic Testing.
4. Disconnect hose connection on gear pump (P2) leading to the steering control valve (Fig. 70).
5. Install T- connector with test gauge in series with the discharge of the gear pump and the disconnected hose leading to the steering control valve.
6. Make sure steering wheel is positioned so the rear wheel points directly ahead.
7. Start engine and move throttle to full speed ( $3050 \pm 50$  RPM).

**IMPORTANT: Do not allow pressure to exceed 1500 PSI.**

**IMPORTANT: Hold steering wheel at full lock only long enough to get a system pressure reading. Holding the steering wheel against the stop for an extended period may damage the steering control valve.**

8. Watch pressure gauge carefully while turning the steering wheel completely in one direction and holding.
9. System pressure should be from **845 to 995 PSI** as the relief valve lifts. Return steering wheel to the center position. If specification is **not** met, shut off engine and repair or replace steering control valve.
10. Disconnect T- connector with test gauge from pump connection and hose. Reconnect hydraulic hose to gear pump (P2).

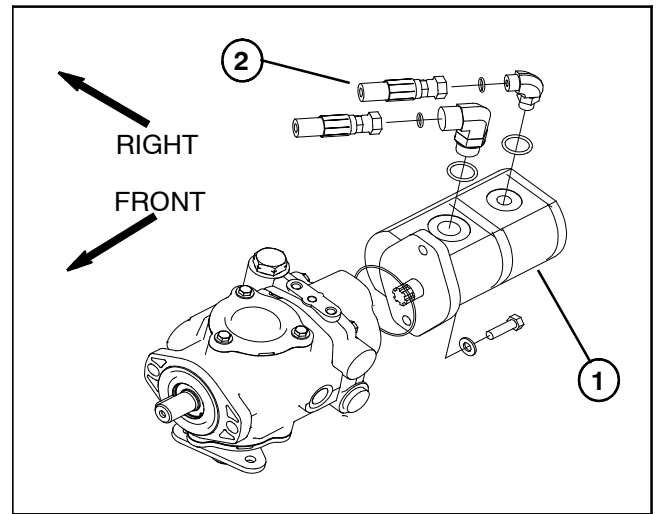
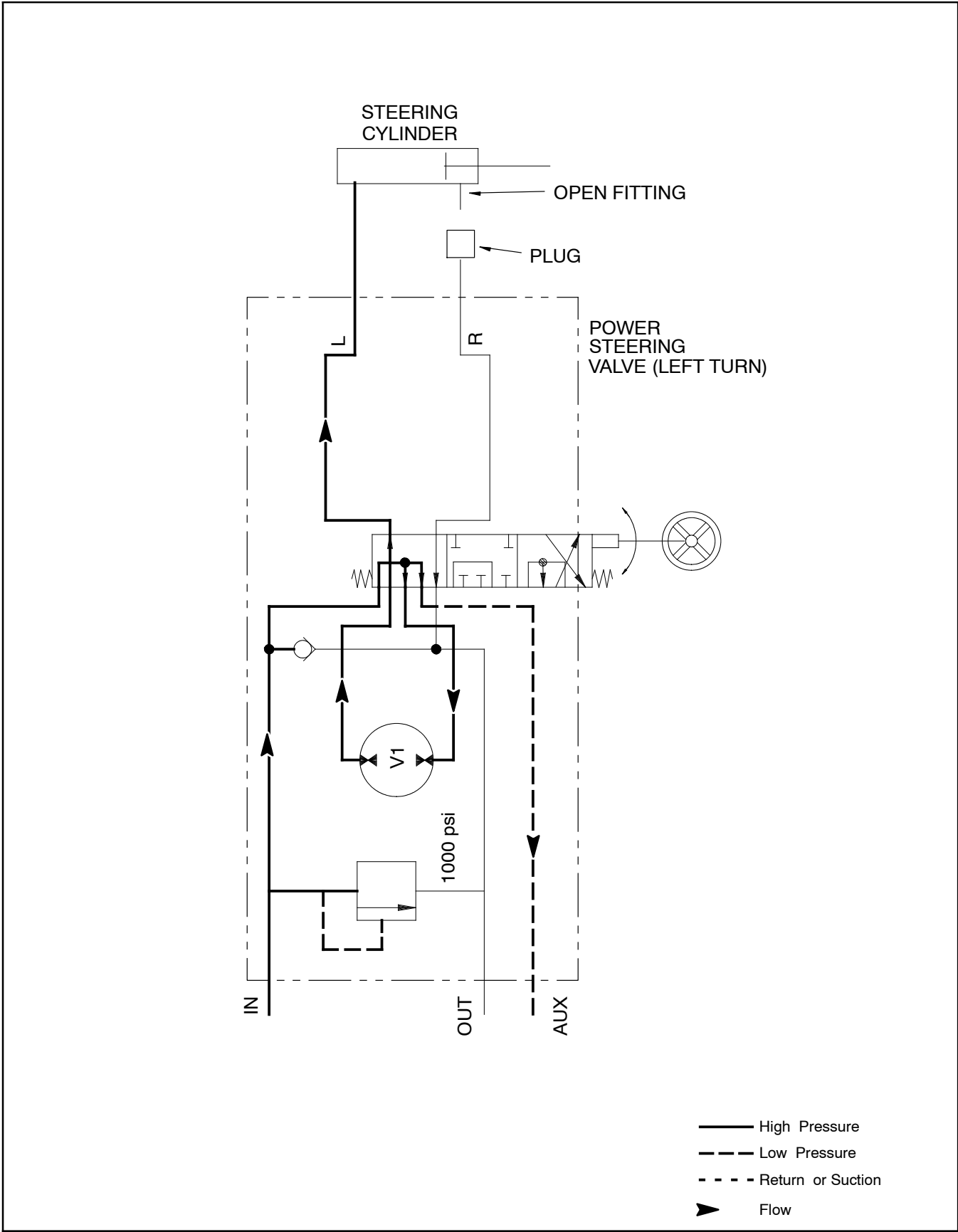

Figure 70

1. Gear pump (P2)
2. To steering control valve

**Steering Control Valve Test**





**Procedure for Steering Control Valve Test:**

1. Make sure hydraulic oil is at normal operating temperature by operating the machine for approximately 10 minutes.

2. Perform the Lift and Steering Control Valve Relief Pressure and Gear Pump (P2) Flow tests to make sure that pump and relief valve are functioning correctly.

**NOTE:** This steering test procedure will be affected by incorrect rear tire pressure, binding in the hydraulic steering cylinder, extra weight on the vehicle, and/or binding of the steering fork assembly. Make sure that these items are checked before proceeding with any hydraulic testing procedure.

3. Drive machine slowly in a figure eight on a flat level surface.

A. There should be no shaking or vibration in the steering wheel or rear wheel.

B. Steering wheel movements should be followed **immediately** by a corresponding rear wheel movement **without** the steering wheel continuing to turn.

4. Stop unit with the engine running. Turn steering wheel with small quick movements in both directions. Let go of the steering wheel after each movement.

A. The steering control valve should respond to each steering wheel movement.

B. When steering wheel is released, steering control should return to the neutral position with no additional turning.

5. If either of these performance tests indicate a steering problem, determine if the steering cylinder is faulty using the following procedure.

A. Park machine on a level surface with the cutting units lowered and off. Make sure engine is off and the parking brake is engaged.

B. Turn the steering wheel all the way to the left (counterclockwise) so the steering cylinder rod is fully extended.

C. Turn engine off.

D. Read Precautions for Hydraulic Testing.

E. Remove hydraulic hose from the 90° fitting on the rod end of the steering cylinder. Plug the end of the hose.

F. With the engine off, continue turning the steering wheel to the left (counterclockwise) with the steering cylinder fully extended. Observe the open fitting on the steering cylinder as the wheel is turned. If oil comes out of the fitting while turning the steering wheel to the left, the steering cylinder has internal leakage and must be repaired or replaced.

G. Remove plug from the hydraulic hose. Reconnect hose to the steering cylinder fitting.

6. If steering problem exists and steering cylinder tested acceptably, steering control requires service (see Steering Control Valve and Steering Control Valve Service in the Service and Repairs section).

# Adjustments

## Adjust Traction Drive for Neutral

If the machine creeps when the traction pedal is in the neutral position, the traction adjustment cam needs adjustment.

1. Park the machine on a level surface and turn the engine off.

	<b>WARNING</b>
<p><b>One front wheel <u>and</u> rear wheel must be raised off the ground or the machine will move during adjustment. Make sure machine is supported so it will not accidentally fall injuring anyone under machine.</b></p>	

2. Raise one front wheel and rear wheel off floor and place support blocks under frame.
3. Loosen locknut on traction adjustment cam.

	<b>WARNING</b>
<p><b>Engine must be running so final adjustment of the traction adjustment cam can be performed. To guard against possible personal injury, keep hands, feet, face and other parts of the body away from the muffler, other hot parts of the engine, and any rotating parts.</b></p>	

4. Start engine and rotate cam hex in both directions to determine mid position of neutral span. When properly set, neither wheel that is off the floor should turn.
5. Tighten locknut to secure adjustment.
6. Stop engine.
7. Remove support blocks and lower the machine to the ground. Test drive the machine to make sure it does not move when in the neutral position. Readjust if necessary.

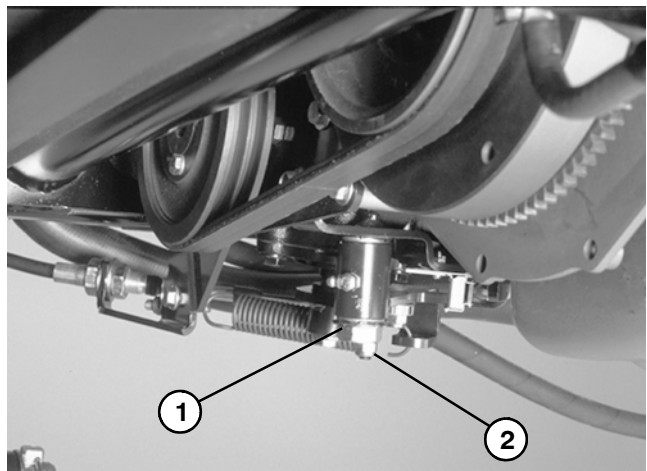

Figure 71

1. Adjustment cam
2. Lock nut

## Braking Valve Adjustment

The braking valve (BV) on the hydraulic manifold controls the stopping time for the cutting deck blades. The braking valve is adjustable. If adjustment of the braking valve is correct, the cutting deck blades should come to a complete stop within 7 seconds after the PTO switch is disengaged.

If blade stopping time is incorrect, adjustment of the braking valve (BV) can be performed as follows:

**NOTE:** Do not remove the braking valve from the hydraulic manifold for adjustment.

1. Loosen lock nut on braking valve (Fig. 72).
2. To **decrease** blade stopping time, turn the adjustment shaft on the valve in a counterclockwise direction.
3. To **increase** blade stopping time, turn the adjustment shaft on the valve in a clockwise direction.
4. Tighten lock nut to secure adjustment.
5. Check blade stopping time and readjust braking valve as needed.

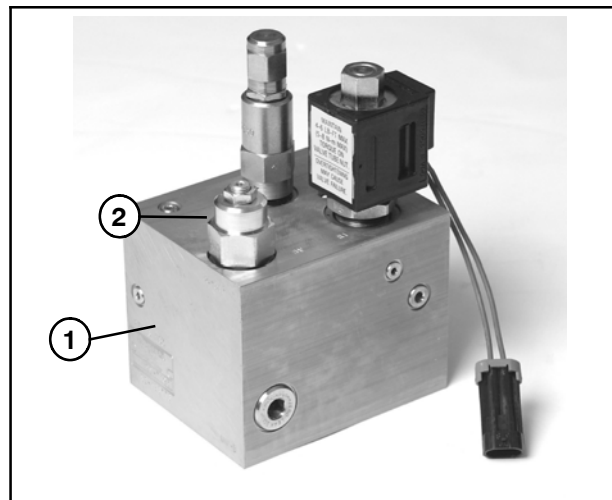

Figure 72

1. Manifold assembly
2. Braking valve (BV)

# Service and Repairs

---

## General Precautions for Removing and Installing Hydraulic System Components

### Before Repair or Replacement of Components

1. Before removing any parts from the hydraulic system, park machine on a level surface, engage parking brake, lower cutting units or attachments, and stop engine. Remove key from the ignition switch.
2. Clean machine before disconnecting, removing, or disassembling any hydraulic components. Make sure hydraulic components, hoses, connections, and fittings are cleaned thoroughly. Always keep in mind the need for cleanliness when working on hydraulic components.



### CAUTION

**Operate all hydraulic controls to relieve system pressure and avoid injury from pressurized hydraulic oil. Controls must be operated with the ignition switch in RUN and the engine OFF. Make sure all electrically operated control valves are actuated. Return ignition switch to OFF when pressure has been relieved. Remove key from the ignition switch.**

3. Put caps or plugs on any hydraulic lines, hydraulic fittings, and components left open or exposed to prevent contamination.
4. Put labels on disconnected hydraulic lines and hoses for proper installation after repairs are completed.
5. Note the position of hydraulic fittings (especially elbow fittings) on hydraulic components before removal. Mark parts if necessary to make sure they will be aligned properly when reinstalling hydraulic hoses and tubes.

### After Repair or Replacement of Components

1. Check oil level in the hydraulic reservoir and add correct oil if necessary. Drain and refill hydraulic system reservoir, and change oil filter if component failure was severe or system is contaminated (see Flush Hydraulic System).
2. Lubricate O-rings and seals with clean hydraulic oil before installing hydraulic components.
3. Make sure caps or plugs are removed from the hydraulic tubes, hydraulic fittings, and components before reconnecting.
4. Use proper tightening methods when installing hydraulic hoses and fittings (see Hydraulic Fitting Installation).
5. After repairs, check control linkages or cables for proper adjustment, binding, or broken parts.
6. After disconnecting or replacing any hydraulic components, operate machine functions slowly until air is out of system (see Charge Hydraulic System).
7. Check for hydraulic oil leaks. Shut off engine and correct leaks if necessary. Check oil level in hydraulic reservoir and add correct oil if necessary.

## Change Hydraulic Fluid

Change hydraulic fluid after every 400 operating hours or yearly, under normal conditions. If fluid becomes contaminated, the complete hydraulic system must be flushed (see Flush Hydraulic System). Contaminated fluid looks milky or black when compared to clean oil.

1. Position machine on a level surface, lower the cutting units, stop the engine, engage the parking brake and remove key from ignition switch.

2. Thoroughly clean area around the hydraulic suction hose at gear pump (Fig. 73). Disconnect suction hose and let hydraulic fluid flow into drain pan. Reinstall hose when hydraulic fluid stops draining.

3. Fill hydraulic tank with approximately 6 gallons (22.6 liters) of hydraulic fluid. Refer to Check Hydraulic Fluid.

**IMPORTANT: Use only hydraulic fluids specified. Other fluids could cause system damage.**

4. Install hydraulic tank cap. Start engine and use all hydraulic controls to distribute hydraulic fluid throughout the system. Also, check for leaks, then stop the engine.

5. Check level of hydraulic fluid and add enough fluid to raise level to FULL mark on dipstick. DO NOT OVER FILL.

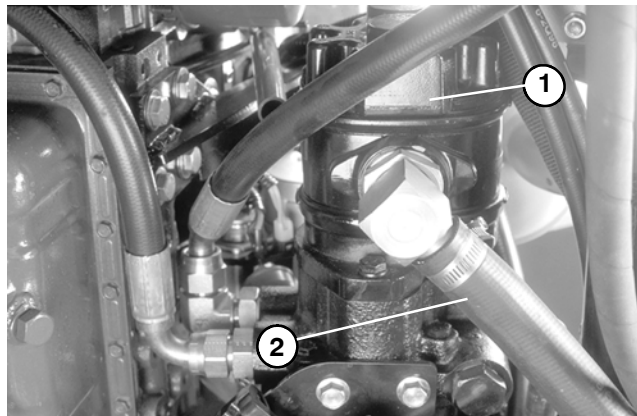

Figure 73

1. Gear pump                      2. Suction hose from tank

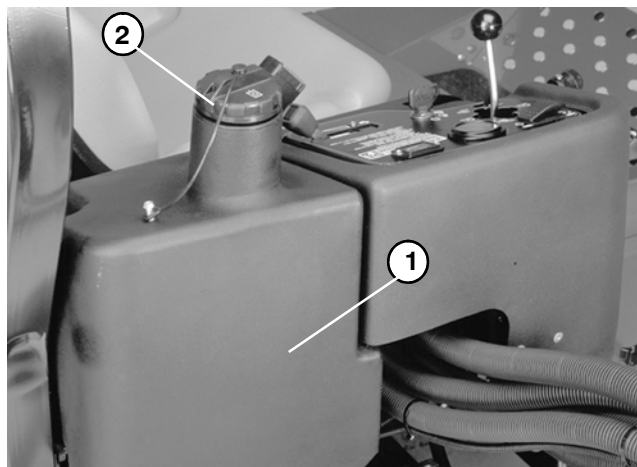

Figure 74

1. Hydraulic tank                2. Cap

## Replace Hydraulic Oil Filter

The hydraulic system oil filter must be changed initially, after the first 10 hours of operation, and thereafter every 200 hours of operation or yearly, whichever comes first.

Use a genuine Toro oil filter (Part No. 54-0110) for replacement.

**IMPORTANT: Use of any other filter may void the warranty on some components.**

1. Position machine on a level surface, lower the cutting units, stop the engine, engage the parking brake and remove key from ignition switch.
2. Clamp hose leading to the oil filter head from the hydraulic tank to prevent draining the hydraulic tank.
3. Clean area around filter mounting surface. Place drain pan under filter and remove filter. Properly dispose of filter.
4. Fill the new filter with hydraulic fluid and lubricate filter gasket.
5. Assure filter mounting surface is clean. Screw filter on until filter gasket contacts mounting plate. Then tighten filter an additional 3/4 turn.
6. Fill hydraulic tank with approximately 6 gallons (22.6 liters) of hydraulic fluid. Refer to Change Hydraulic Fluid. Remove clamp from hydraulic hose.
7. Start engine and let run for about two minutes to purge air from the hydraulic system. Stop the engine, check for leaks, and re-check hydraulic fluid level.

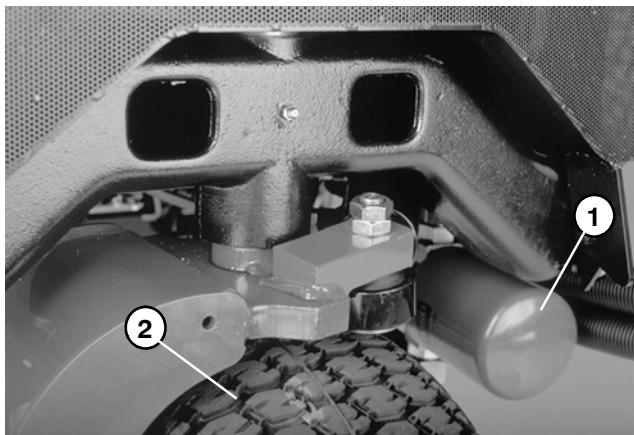

Figure 75

1. Hydraulic oil filter
2. Rear wheel

## Replace Traction Belt

1. Park machine on a level surface, lower cutting units, stop engine, engage parking brake, and remove key from the ignition switch. Raise hood.

2. Insert nut driver or small piece of pipe onto the end of the torsion spring of the idler pulley.

	<b>CAUTION</b>
<b>Be careful when removing or applying tension from or to the torsion spring of the idler pulley. The spring is under heavy load and may cause personal injury.</b>	

3. Push down and forward on the spring end to unhook the spring from the pump mounting plate.

4. Remove V-belt from the engine flywheel and hydrostat pulleys.

5. Install new V-belt onto the engine flywheel and hydrostat pulleys.

6. Insert nut driver or small piece of pipe onto the end of the torsion spring of the idler pulley.

7. Push down and back on the spring end to get the spring under the pump mounting plate notch. Then release the spring slowly to lock it into place.

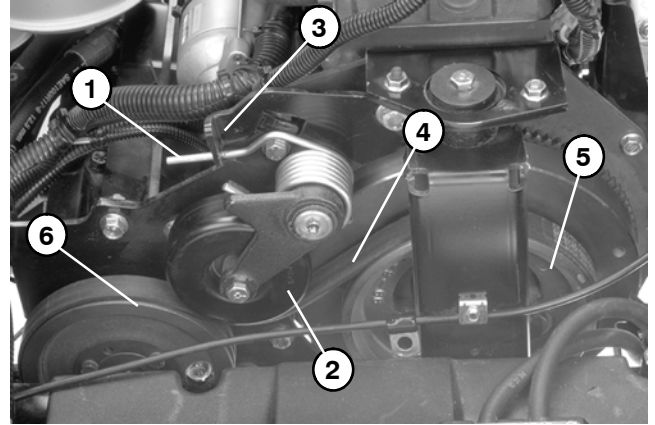

Figure 76

- |                        |                     |
|------------------------|---------------------|
| 1. Torsion spring      | 4. V-belt           |
| 2. Idler pulley        | 5. Flywheel pulley  |
| 3. Pump mounting plate | 6. Hydrostat pulley |

---

## Check Hydraulic Lines and Hoses



### **WARNING**

**Keep body and hands away from pin hole leaks or nozzles that eject hydraulic fluid under high pressure. Use paper or cardboard, not hands, to search for leaks. Hydraulic fluid escaping under pressure can have sufficient force to penetrate the skin and cause serious injury. If fluid is injected into the skin, it must be surgically removed within a few hours by a doctor familiar with this type of injury. Gangrene may result from such an injury.**

Check hydraulic lines and hoses daily for leaks, kinked lines, loose mounting supports, wear, loose fittings, weather deterioration and chemical deterioration. Make any necessary repairs before operating equipment.



---

## Flush Hydraulic System

**IMPORTANT:** Flush the hydraulic system any time there is a severe component failure or if the system is contaminated (oil appears milky, black, or contains metal particles).

**IMPORTANT:** Flush hydraulic system when changing from petroleum base hydraulic fluid to a biodegradable fluid such as Toro Biodegradable Hydraulic Fluid. Operate machine under normal operating conditions for at least four (4) hours before draining.

**IMPORTANT:** If a component failure occurred in the traction circuit, refer to Traction Circuit (Closed Loop) Component Failure in the General Information section for information regarding the importance of removing contamination from the traction circuit.

1. Park machine on a level surface. Lower cutting units, stop engine, and engage parking brake. Remove key from the ignition switch.



### WARNING

Before disconnecting or performing any work on the hydraulic system, all pressure in the system must be relieved. See Relieving Hydraulic System Pressure in the General Information section.

**IMPORTANT:** Make sure to clean around any hydraulic connections that will be disassembled.

2. Drain hydraulic tank (see Change Hydraulic Fluid).
3. Drain hydraulic system. Drain all hoses, tubes, and components while the system is warm.
4. Change and replace oil filter (see Replace Hydraulic Oil Filter).
5. Inspect and clean hydraulic oil tank (see Hydraulic Tank Inspection).

6. Reconnect all hydraulic hoses, lines, and components that were disconnected while draining system.

**NOTE:** Use only hydraulic fluids specified in Check Hydraulic System Fluid. Other fluids may cause system damage. If changing to biodegradable fluid, use Toro Biodegradable Hydraulic Fluid for this step.

7. Fill hydraulic tank with **new** hydraulic fluid (see Change Hydraulic Fluid).

8. Disconnect fuel stop solenoid lead to prevent the engine from starting. Make sure traction pedal and the lift control lever are in the **neutral** position.

9. Turn ignition key switch and engage starter for ten (10) seconds to prime the traction and gear pumps. Wait fifteen (15) seconds to allow the starter motor to cool and then repeat cranking procedure again.

10. Connect electrical connector on fuel stop solenoid.

11. Start engine and let it idle at low speed ( $1750 \pm 50$  RPM) for a minimum of 2 minutes. Increase engine speed to high idle ( $3050 \pm 50$  RPM) for a minimum of 1 minute under no load.

12. Raise and lower cutting units several times. Turn steering wheel fully left and right several times.

13. Shut off engine and check for hydraulic oil leaks. Check oil level in hydraulic tank and add correct amount of oil if necessary.

14. Operate the machine for 2 hours under normal operating conditions.

15. Check condition of hydraulic oil. If the new fluid shows any signs of contamination, repeat steps 1 through 14 again until oil is clean. If changing to biodegradable fluid, repeat steps 1 through 14 again at least once and until the oil is clean.

16. Assume normal operation and follow recommended maintenance intervals.

## Filtering Closed- Loop Traction Circuit

Filtering of a closed- loop hydraulic system after a major component failure (e.g. traction (piston) pump or wheel motor) is a requirement to prevent debris from transmitting throughout the system. If a closed- loop hydraulic system filtering tool is not used (to ensure system cleanliness) repeat failures and subsequent damage to other hydraulic components in the system will occur. To effectively remove contamination from closed- loop traction circuit, use of the Toro high flow hydraulic filter and hydraulic hose kit are recommended (see Special Tools in this chapter).

1. Park machine on a level surface, stop engine and remove key from ignition switch.

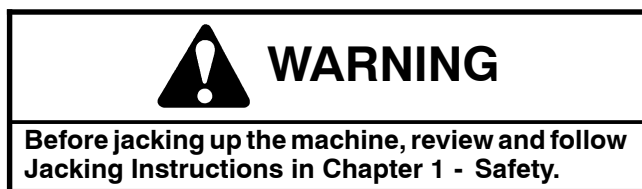

2. Raise and support machine so all wheels are off the ground.

**NOTE:** If a wheel motor was replaced, install high flow filter to the inlet (when traveling forward) of new wheel motor instead of to the inlet (when traveling forward) of the traction pump. This will prevent system contamination from entering and damaging the new motor.

3. Thoroughly clean junction of hydraulic hose and lower fitting on rear wheel motor (Fig. 77). Disconnect hose from lower fitting on wheel motor.

4. Connect Toro high flow hydraulic filter in series between wheel motor fitting and disconnected hose. Use hydraulic hose kit (see Special Tools in this chapter) to connect filter to machine. Make sure that fitting and hose connections are properly tightened.

**IMPORTANT:** Use only hydraulic fluids specified in Operator's Manual. Other fluids could cause system damage.

5. After installing high flow filter to machine, check and fill hydraulic reservoir with new hydraulic oil as required.

6. Sit in the operator's seat and start engine. Run engine at low idle speed and check for any hydraulic leakage from filter and hose connections. Correct any leaks before proceeding.

**IMPORTANT:** While engaging the traction circuit, monitor the high flow hydraulic filter indicator. If the indicator should show red, either reduce traction pedal setting or reduce engine speed to decrease hydraulic flow through the filter.

Hydraulic System (Rev. G)

7. With engine running at low idle speed, slowly depress the forward traction pedal to the full forward position to allow flow through the traction circuit and high flow filter. Keep traction circuit engaged for five (5) minutes while gradually increasing both forward pressure on traction pedal and engine speed. Monitor filter indicator to make sure that green color is showing during operation.

8. With engine running at high idle speed and traction pedal moved to the forward direction, periodically apply brakes to increase pressure in traction circuit. While monitoring filter indicator, continue this process for an additional five (5) minutes.

**IMPORTANT:** If using a filter that is not the bi- directional Toro high flow filter, do not press the traction pedal in the reverse direction. If flow is reversed when using a filter that is not bi- directional, debris from the filter will re- enter the traction circuit.

9. With engine running at high idle speed, alternately move traction pedal from forward to reverse. While monitoring filter indicator, continue this process for an additional five (5) minutes.

10. Shut engine off and remove key from ignition switch.

11. Remove high flow hydraulic filter and hydraulic hose kit from machine. Reconnect hydraulic hose to rear wheel motor fitting. Make sure to properly tighten hose (see Hydraulic Hose and Tube Installation in the General Information section of this chapter).

12. Lower machine to ground.

13. Check oil level in hydraulic reservoir and add correct oil if necessary.

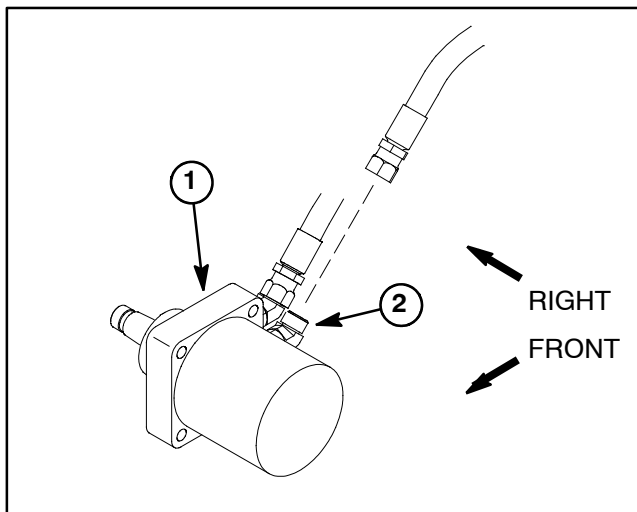

Figure 77

1. Rear wheel motor

2. Lower fitting

## Charge Hydraulic System

**NOTE:** When initially starting the hydraulic system with new or rebuilt components such as motors, pumps, or lift cylinders, it is important that the hydraulic system be charged properly. Air must be purged from the system and its components to reduce the chance of damage.

**IMPORTANT: Change hydraulic oil filter whenever hydraulic components are repaired or replaced.**

1. Park machine on a level surface and turn engine off.
2. Make sure all hydraulic connections, lines, and components are secured tightly.
3. If component failure was severe or the system is contaminated, flush and refill hydraulic system and tank (see Flush Hydraulic System).
4. Make sure hydraulic tank is full. Add correct oil if necessary (see Check Hydraulic System Fluid).
5. Disconnect fuel stop solenoid lead to prevent the engine from starting.
6. Check control cable to the hydrostat for proper adjustment, binding, or broken parts.
7. Make sure traction pedal and the lift control lever are in the **neutral** position. Turn ignition key switch and engage starter for ten (10) seconds to prime the traction and gear pumps. Wait fifteen (15) seconds to allow the starter motor to cool and then repeat cranking procedure again.
8. Reconnect fuel stop solenoid lead.



9. Raise one front and rear wheel off the floor, and place support blocks under the frame. Chock remaining front wheel to prevent movement of the machine.



10. Make sure traction pedal and lift control lever are in **neutral**. Start engine and run it at low idle of 1800 rpm. The charge pump should pick up oil and fill the hydraulic system. If there is no indication of fill in 30 seconds, stop the engine and determine the cause.

11. After the hydraulic system starts to show signs of fill, actuate lift control lever until the lift cylinder rod moves in and out several times. If the cylinder rod does not move after 10 to 15 seconds, or the pump emits abnormal sounds, shut the engine off immediately and determine cause or problem. Inspect for the following:

- A. Loose filter or suction lines.
- B. Incorrect hydraulic hose routing.
- C. Loose or faulty coupler on the pump.
- D. Blocked suction line.
- E. Faulty charge relief valve.
- F. Faulty charge pump (Gear Pump P2).

12. If cylinder moves in 10 to 15 seconds, proceed to step 13.

13. Operate the traction pedal in the forward and reverse directions. The wheels off the floor should rotate in the proper direction.

- A. If the wheels rotate in the wrong direction, stop engine, remove lines from rear of hydrostat pump, and reverse the connections.
- B. If the wheels rotate in the proper direction, stop engine.

14. Adjust traction pedal to the neutral position (see Adjust Traction Drive for Neutral).

15. Check operation of the traction interlock switch (see Check Interlock System in Chapter - 5, Electrical Systems).

16. Remove blocks from wheels and lower machine. Remove chocks from remaining wheel.

17. If the traction pump or a wheel motor was replaced or rebuilt, run the traction unit so all wheels turn slowly for 10 minutes.

18. Operate traction unit by gradually increasing its work load to full over a 10 minute period.

19. Stop the machine. Check hydraulic tank and fill if necessary. Check hydraulic components for leaks and tighten any loose connections.

# Hydraulic Tank and Hydraulic Oil Filter

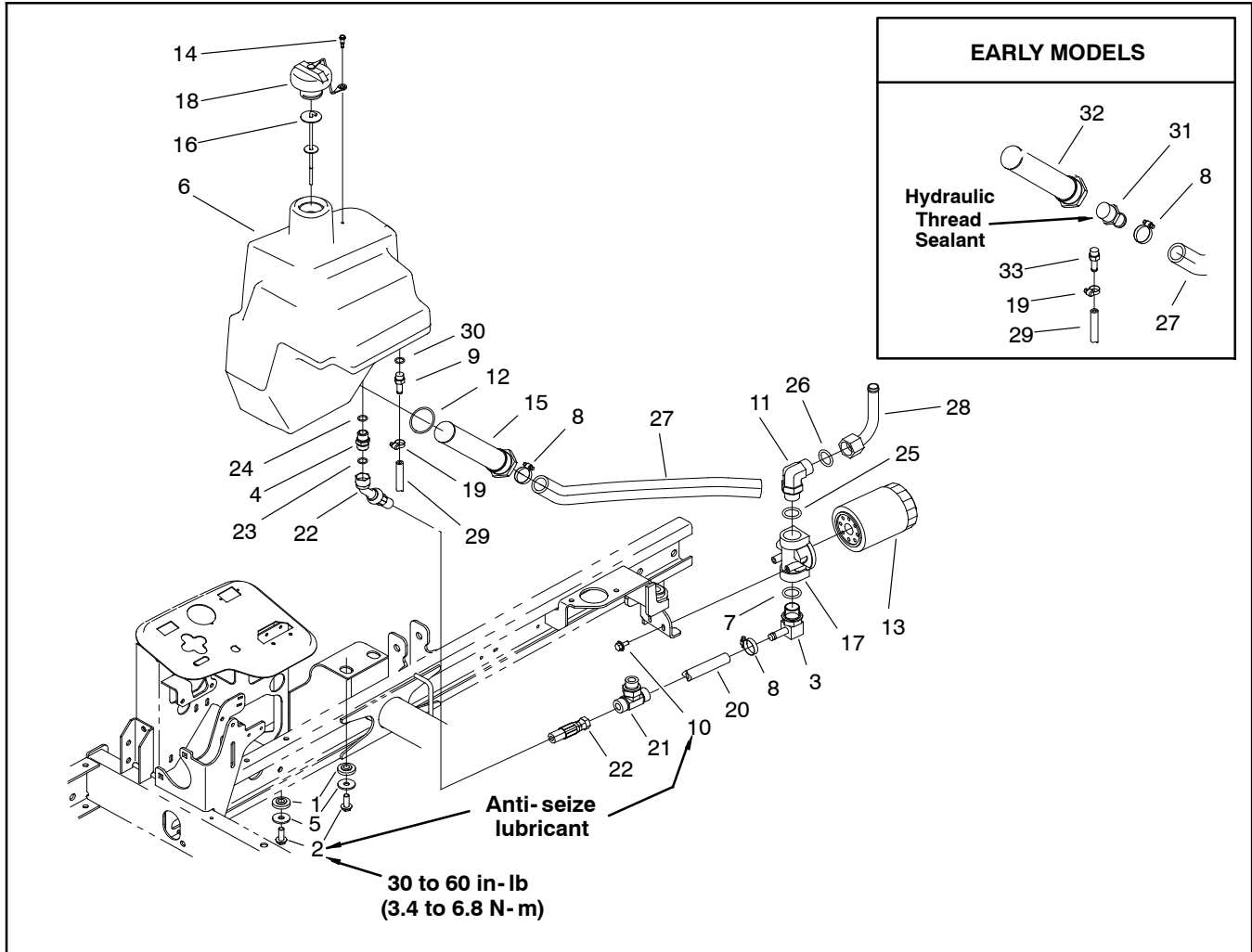

Figure 78

- |                            |                        |                                      |
|----------------------------|------------------------|--------------------------------------|
| 1. Grommet                 | 12. O-ring             | 23. O-ring                           |
| 2. Flange head screw       | 13. Oil filter element | 24. O-ring                           |
| 3. Barb fitting            | 14. Shoulder screw     | 25. O-ring                           |
| 4. Check fitting           | 15. Suction strainer   | 26. O-ring                           |
| 5. Flat washer             | 16. Dipstick           | 27. Hydraulic hose (suction)         |
| 6. Hydraulic tank          | 17. Filter head        | 28. Hydraulic tube (from oil cooler) |
| 7. O-ring                  | 18. Hydraulic tank cap | 29. Hydraulic hose (from manifold)   |
| 8. Hose clamp              | 19. Hose clamp         | 30. O-ring                           |
| 9. Barb fitting (straight) | 20. Hydraulic hose     | 31. Barb fitting (early models)      |
| 10. Flange head screw      | 21. Tee fitting        | 32. Suction strainer (early models)  |
| 11. Elbow fitting          | 22. Hydraulic hose     | 33. Barb fitting (early models)      |

### Hydraulic Tank Removal

1. Drain hydraulic oil from Hydraulic tank (see Change Hydraulic Fluid).
2. Remove hydraulic tank using Figure 78 as a guide. Discard and replace any O-rings that are removed.

### Hydraulic Tank Inspection (Fig. 78)

1. Clean hydraulic tank and suction strainer with solvent.
2. Inspect hydraulic tank for leaks, cracks, or other damage.

### Hydraulic Tank Installation

1. Apply anti-seize lubricant or equivalent to the two flange head screws that secure the hydraulic tank. Tighten the tank mounting screws from 30 to 60 in-lb (3.4 to 6.8 N-m). Install tank using Figure 78 as a guide.
2. Thread suction strainer into hydraulic tank. **Note:** Early models used a two piece suction strainer assembly. On early models only, use hydraulic thread sealant on threads of suction strainer and barb fittings during re-assembly. Do not apply sealant to the first thread of the fittings.
3. Using a wrench, turn strainer into tank port at least 1- 1/2 to 2 full turns beyond finger tight.
4. Fill hydraulic tank with **new** hydraulic fluid (see Change Hydraulic Fluid).

## Oil Cooler

**Note:** On Groundsmaster 3500- D machines with serial numbers above 314000000, the hydraulic oil cooler is combined with the radiator.

### Removal



## CAUTION

The radiator and oil cooler may be hot. To avoid possible burns, allow the engine and cooling systems to cool before working on the oil cooler.

1. Remove oil cooler using Figures 79 and 80 as guides.

### Inspection



## CAUTION

Use eye protection such as goggles when using compressed air.

1. Back flush oil cooler with cleaning solvent. After cooler is clean, make sure all solvent is drained from the cooler.
2. Dry inside of oil cooler using compressed air in the opposite direction of the oil flow.
3. Plug both ends of oil cooler. Clean exterior of cooler. Make sure oil cooler fins are clear of dirt and debris.
4. The oil cooler should be free of corrosion, cracked tubes, or excessive pitting of tubes.

### Installation

1. Install oil cooler using Figures 79 and 80 as guides.
2. Make sure hydraulic tank is full. Add correct oil if necessary (see Check Hydraulic System Fluid).

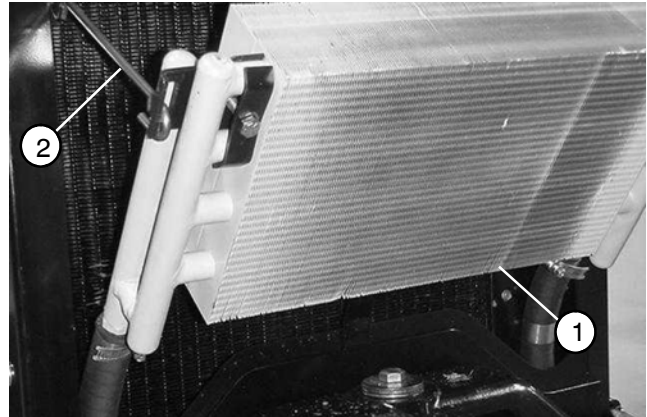

Figure 79

1. Oil cooler
2. Latch

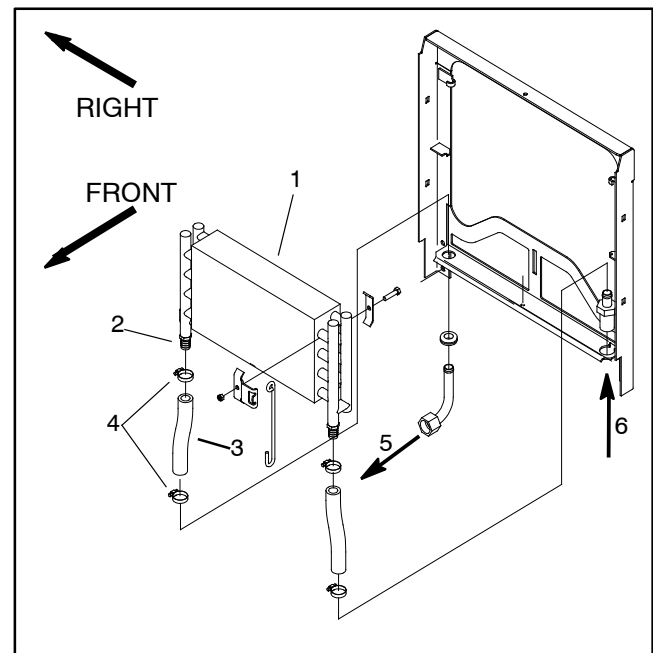

Figure 80

1. Oil cooler
2. Barb fitting
3. Hydraulic hose
4. Hose clamp
5. Flow to oil filter
6. Flow from manifold

This page is intentionally blank.

**Front Wheel Motors**

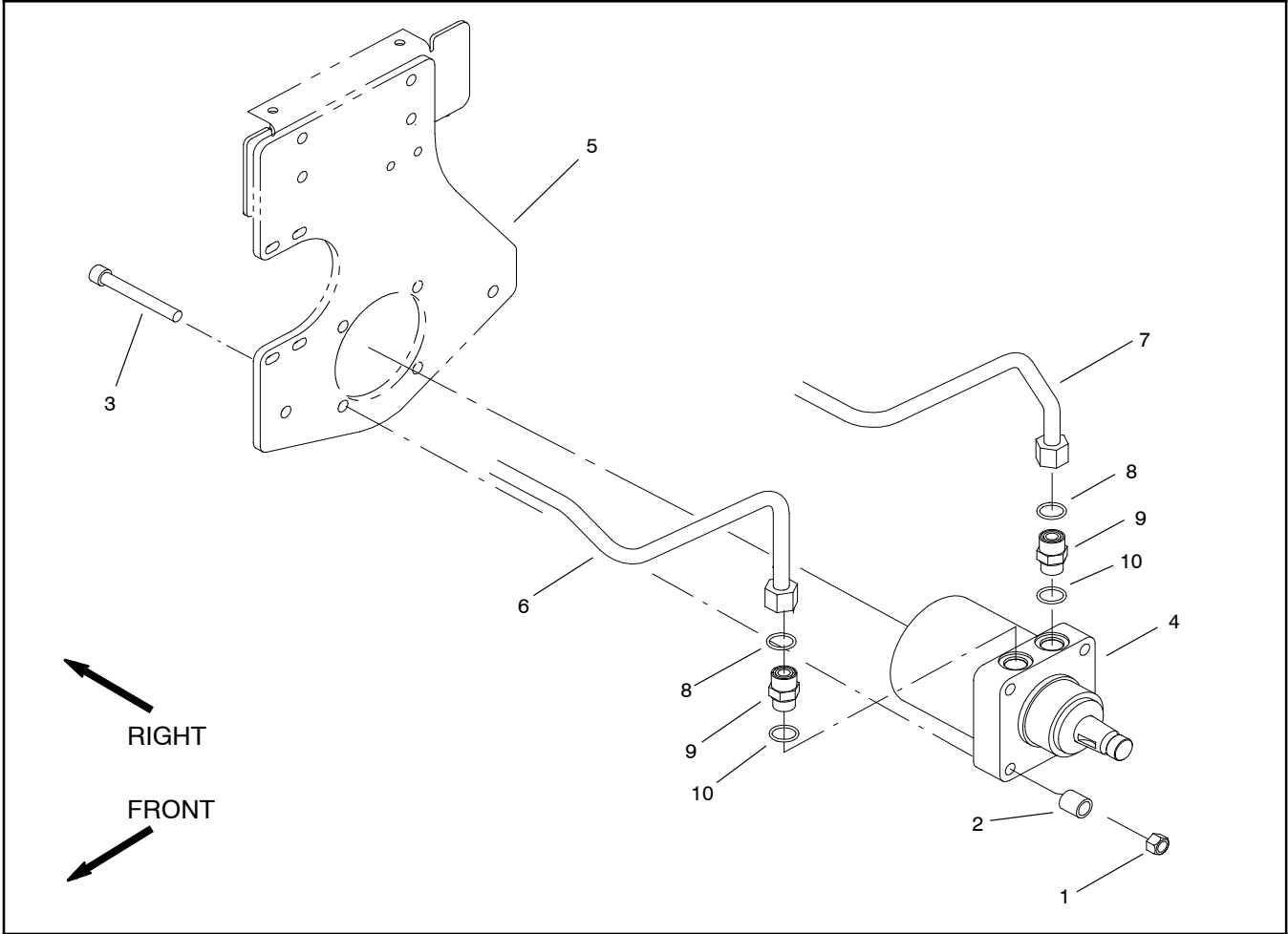

Figure 81

- 1. Lock nut
- 2. Spacer
- 3. Socket head screw
- 4. Hydraulic wheel motor

- 5. Frame
- 6. Hydraulic tube
- 7. Hydraulic tube

- 8. O-ring
- 9. Hydraulic fitting
- 10. O-ring



## Removal

1. Park machine on a level surface, lower cutting units, stop engine, engage parking brake, and remove key from the ignition switch.



2. Jack up front of equipment enough to allow the removal of the front wheel.

**IMPORTANT: DO NOT hit wheel hub, wheel hub puller or motor with a hammer during removal or installation. Hammering may cause damage to the hydraulic motor.**

3. Remove tire and wheel assembly, wheel hub, and brake drum from the hydraulic motor. Remove brake assembly, brake bracket, and wheel shield from the frame (see Front Wheel and Brake Removal in Chapter 6 - Wheels, Brakes, and Miscellaneous).

4. Remove wheel motor from frame using Figure 81 as guide.

## Installation

1. Install wheel motor to frame using Figure 81 as guide.

2. Install wheel shield, brake bracket, and brake assembly to the frame. Install brake drum, wheel hub, and tire and wheel assembly to the hydraulic motor (see Front Wheel and Brake Installation in Chapter 6 - Wheels, Brakes, and Miscellaneous).

3. Lower the machine to the ground.

## Rear Wheel Motor

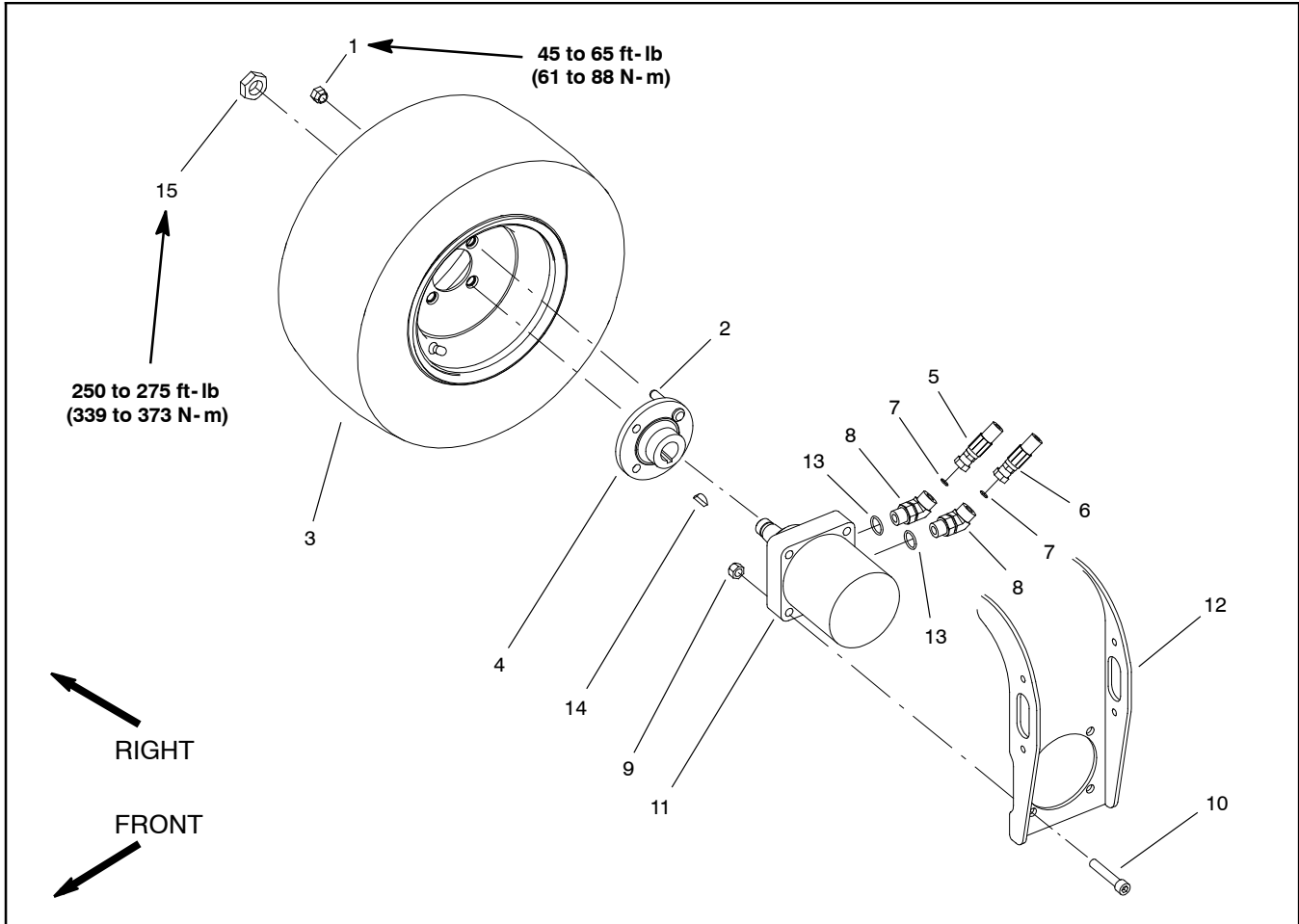

Figure 75

- |                          |                          |                     |
|--------------------------|--------------------------|---------------------|
| 1. Lug nut               | 6. Hydraulic hose        | 11. Hydraulic motor |
| 2. Drive stud            | 7. O-ring                | 12. Rear fork       |
| 3. Tire and rim assembly | 8. 45° hydraulic fitting | 13. O-ring          |
| 4. Wheel hub             | 9. Lock nut              | 14. Woodruff key    |
| 5. Hydraulic hose        | 10. Socket head screw    | 15. Lock nut        |

### Removal (Fig. 75)

1. Park machine on a level surface, lower cutting units, stop engine, engage parking brake, and remove key from the ignition switch.



## WARNING

**Before jacking up the machine, review and follow Jacking Instructions in Chapter 1 - Safety.**

2. Jack up rear of equipment enough to allow the removal of the rear wheel.
3. Remove rear tire and rim assembly from machine.

4. Remove rear wheel motor with wheel hub attached from the rear fork using Figure 75 as guide.

5. Secure wheel hub in a vise. Loosen but do not remove lock nut that secures wheel hub to wheel motor.

**IMPORTANT: DO NOT hit wheel hub, wheel hub puller or wheel motor with a hammer during wheel hub removal or installation. Hammering may cause damage to the wheel motor.**

6. Using hub puller (see Special Tools), loosen wheel hub from wheel motor.

7. Remove wheel hub and motor from vise. Remove lock nut and hub from motor shaft. Locate and retrieve woodruff key.

8. If hydraulic fittings are to be removed from wheel motor, mark fitting orientation to allow correct assembly.

### **Installation (Fig. 75)**

1. If hydraulic fittings were removed from wheel motor, install fittings to motor using marks made during the removal process to properly orientate fittings.

2. Thoroughly clean wheel motor shaft and wheel hub taper.

3. Lock wheel hub in a vise. Install woodruff key into the wheel motor shaft. Slide motor shaft into hub and secure with lock nut. Torque lock nut from 250 to 275 ft- lb (339 to 373 N- m). Remove wheel motor and hub from vise.

4. Install wheel motor to the rear fork using Figure 75 as guide.

5. Install tire and rim assembly to machine.

6. Lower the machine to the ground.

7. Torque rear wheel lug nuts from 45 to 65 ft- lb (61 to 88 N- m).

8. Make sure hydraulic tank is full. Add correct oil if necessary (see Check Hydraulic System Fluid).

## Wheel Motor Service

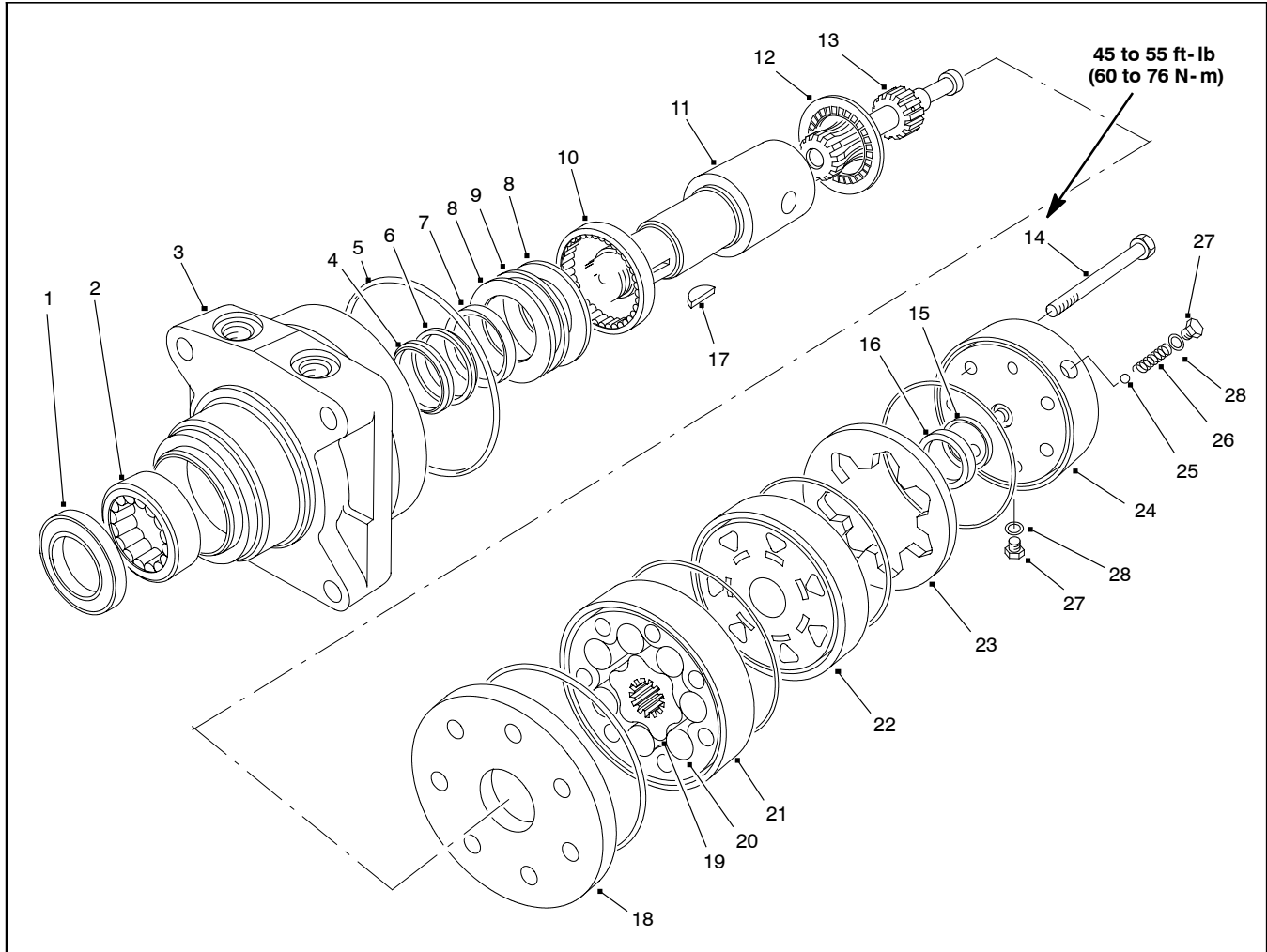

Figure 83

- |                   |                     |                     |
|-------------------|---------------------|---------------------|
| 1. Dirt seal      | 11. Coupling shaft  | 20. Vane            |
| 2. Bearing        | 12. Thrust bearing  | 21. Stator          |
| 3. Housing        | 13. Drive link      | 22. Manifold        |
| 4. Back-up washer | 14. Cap screw       | 23. Commutator ring |
| 5. Seal rings     | 15. Commutator seal | 24. End cover       |
| 6. Back-up washer | 16. Commutator      | 25. Ball            |
| 7. Inner seal     | 17. Woodruff key    | 26. Spring          |
| 8. Thrust washer  | 18. Wear plate      | 27. Plug            |
| 9. Thrust bearing | 19. Rotor           | 28. O-ring          |
| 10. Bearing       |                     |                     |

**Note:** The wheel motor illustrated in Figure 83 is the rear motor. The three wheel motors are identical in construction except for some minor differences. The right front and rear wheel motors have reverse timed manifolds, and the front left motor does not. The end cover of the rear motor has a check valve consisting of a ball and spring, and both front motors lack this feature.

**IMPORTANT:** If a wheel motor failure occurred, refer to Traction Circuit (Closed Loop) Component Failure in the General Information section for information regarding the importance of removing contamination from the traction circuit.

**Note:** For repair of the wheel motors, see the Ross Torqmotor™ MG, MF, MP, MB, ME, and MJ Series Service Procedure at the end of this chapter.

This page is intentionally blank.

# Rotary Cutting Motors

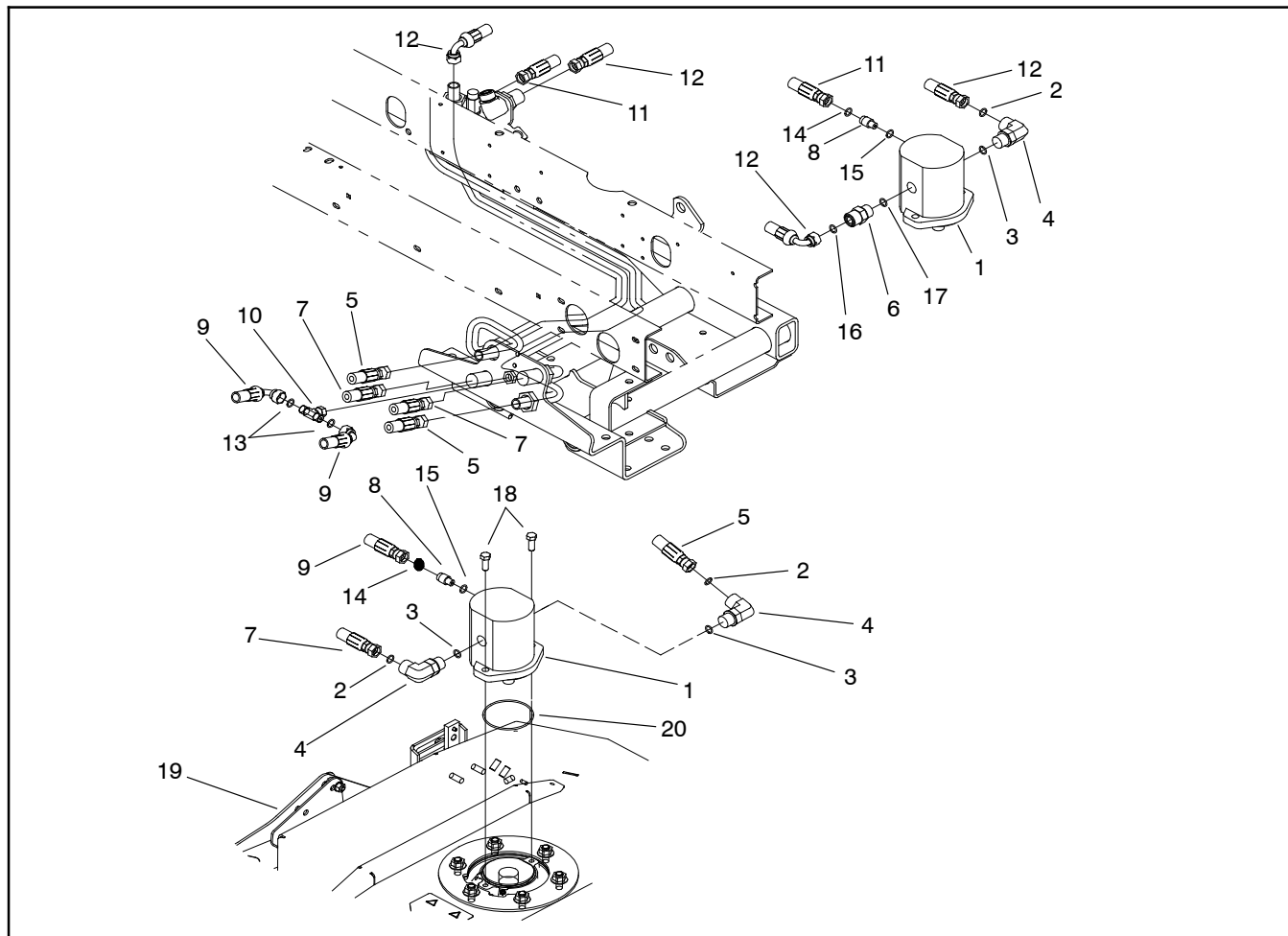

Figure 84

- |                      |                         |                  |
|----------------------|-------------------------|------------------|
| 1. Hydraulic motor   | 8. Hydraulic fitting    | 15. O-ring       |
| 2. O-ring            | 9. Hydraulic hose       | 16. O-ring       |
| 3. O-ring            | 10. Hydraulic T-fitting | 17. O-ring       |
| 4. Hydraulic elbow   | 11. Hydraulic hose      | 18. Cap screw    |
| 5. Hydraulic hose    | 12. Hydraulic hose      | 19. Cutting deck |
| 6. Hydraulic adapter | 13. O-ring              | 20. O-ring       |
| 7. Hydraulic hose    | 14. O-ring              |                  |

### Removal (Fig. 84)

**Note:** Note position of hydraulic hoses when removing from the rotary motors. Proper positioning is critical when reconnecting hydraulic hoses. The inlet to the motor is opposite from the relief valve (Fig. 85).

1. Remove two cap screws that secure hydraulic motor to the cutting unit (Fig. 85). Remove hydraulic motor from deck and O- ring from top of spindle housing.
2. Remove hydraulic hoses from rotary motors using Figure 84 as a guide.
3. If hydraulic fittings are to be removed from motor, mark fitting orientation to allow correct assembly.

### Installation (Fig. 84)

1. If hydraulic fittings were removed from motor, install fittings to motor using marks made during the removal process to properly orientate fittings.
2. Position O- ring to top of spindle housing. Install hydraulic motor to the cutting unit with two cap screws.
3. Install hydraulic hoses to rotary motors using Figure 84 as a guide.
4. Make sure hydraulic tank is full. Add correct oil if necessary (see Check Hydraulic System Fluid).

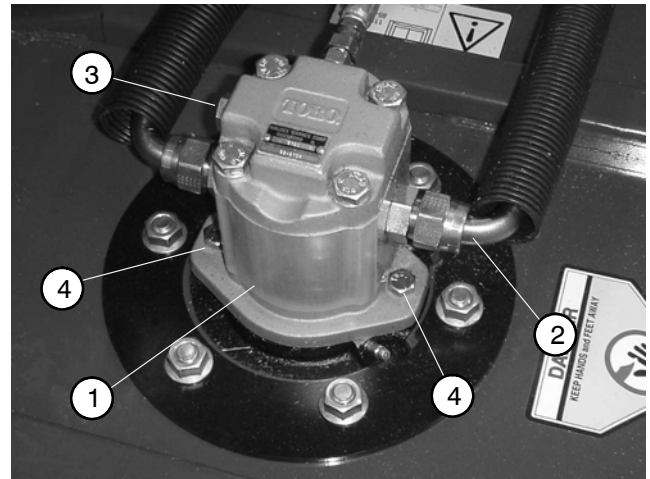

Figure 85

- |                         |                 |
|-------------------------|-----------------|
| 1. Hydraulic deck motor | 3. Relief valve |
| 2. Inlet hose           | 4. Cap screw    |

## Rotary Cutting Motor Service (Haldex)

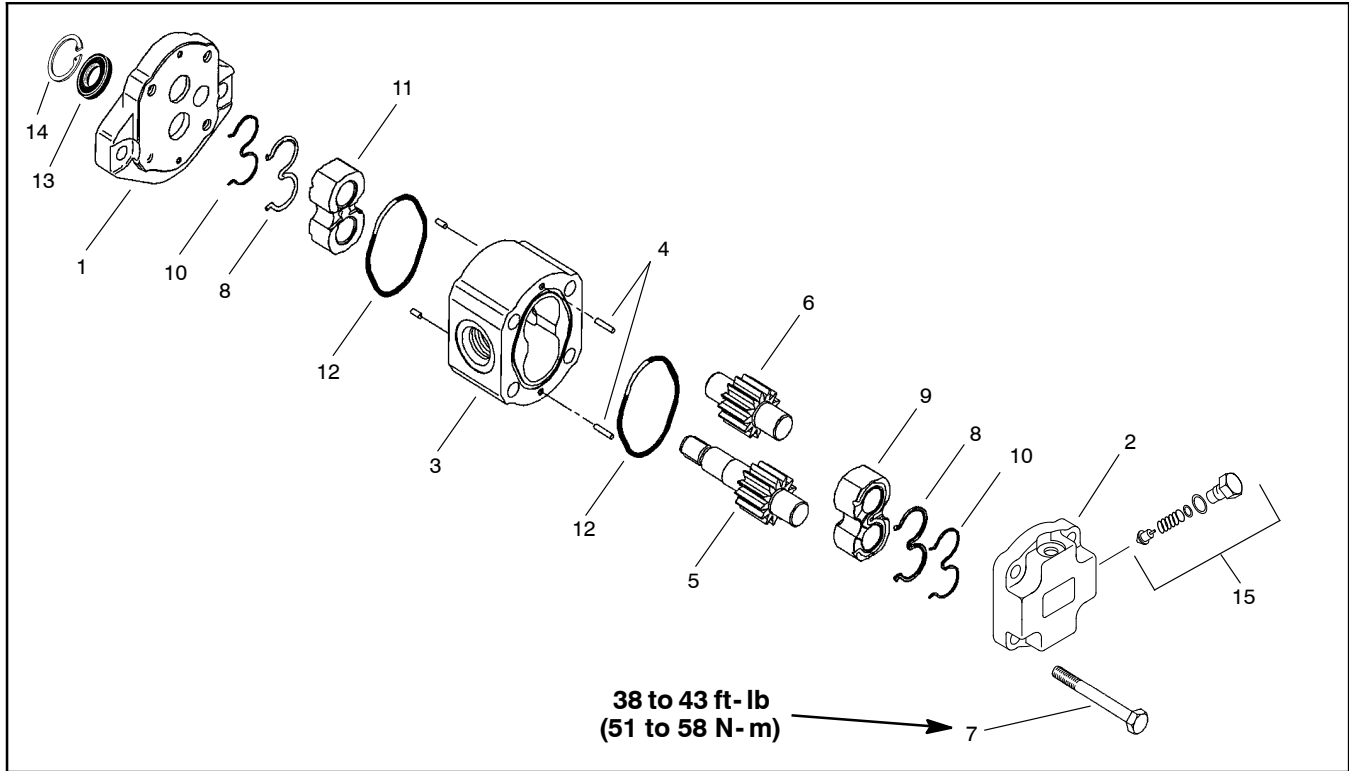

Figure 86

- |                |                    |                      |
|----------------|--------------------|----------------------|
| 1. Front plate | 6. Idler gear      | 11. Front wear plate |
| 2. Back plate  | 7. Cap screw       | 12. O-ring           |
| 3. Body        | 8. Back-up gasket  | 13. Shaft seal       |
| 4. Dowel       | 9. Rear wear plate | 14. Retaining ring   |
| 5. Drive gear  | 10. Pressure seal  | 15. Relief valve kit |

### Disassembly (Fig. 86)

1. Plug motor ports and clean the outside of the motor thoroughly. After cleaning, remove plugs and drain any oil out of the motor.

2. Use a marker to make a **diagonal** line across the front plate, body, and back plate for assembly purposes (Fig. 87).

**IMPORTANT: Avoid using excessive clamping pressure on the motor housing to prevent distorting the housing.**

3. Clamp mounting flange of motor in a vise with the shaft end down.

4. Loosen cap screws from the back plate.

5. Remove motor from the vise. Turn motor so that the shaft end is facing down. Remove cap screws.

6. Remove back plate from the body.

7. Carefully remove body. Lift body straight up to remove. Make sure the rear wear plate remains on the drive and idler gear shafts. Remove and discard O-rings from the body. Locate and retrieve dowel pins.

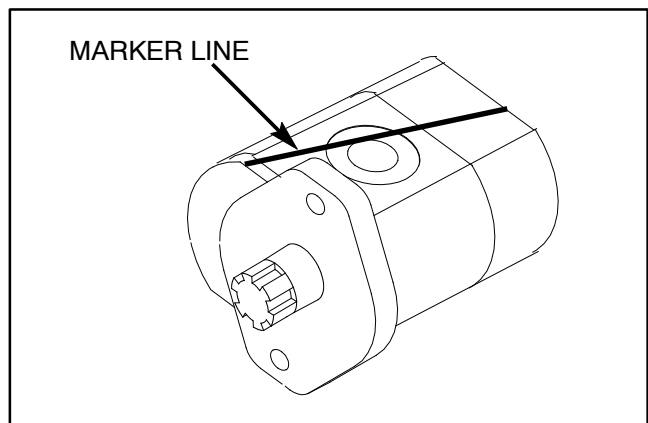

Figure 87



**IMPORTANT:** Note position of the open and closed side of the wear plates before removing. Also, identify wear plates (front and rear) with a marker for proper assembly.

8. Carefully remove rear wear plate, idler gear, drive gear, and front wear plate from the front plate.

9. Remove and discard back-up gaskets and pressure seals from wear plates.

10. Turn front plate over, with seal side up, and remove the retaining ring using snap ring pliers.

**IMPORTANT:** Make sure not to damage the counter bore when removing the shaft seal from the front plate.

11. Remove and discard shaft seal from the front plate.

### Inspection

1. Remove any nicks and burrs from all parts with emery cloth.



2. Clean all parts with solvent. Dry all parts with compressed air.

3. Inspect drive gears and idler gears for the following (Fig. 88):

A. Drive gear shaft spline should be free of twisted or broken teeth.

B. Gear shafts should be free of rough surfaces and excessive wear at bushing points and sealing areas. Scoring, rough surfaces, or wear on gear shafts indicates need for replacement.

C. Gear teeth should be free of excessive scoring and wear. Any broken or nicked gear teeth must be replaced.

D. Inspect gear face edge for sharpness. Sharp edges of gears will mill into wear plates and, thus, must be replaced.

4. Inspect wear plates for the following:

A. Bearing areas should not have excessive wear or scoring.

B. Face of wear plates that are in contact with gears should be free of wear, roughness or scoring.

C. Thickness of wear plates should be equal.

5. Inspect front plate and back plate for damage or wear.

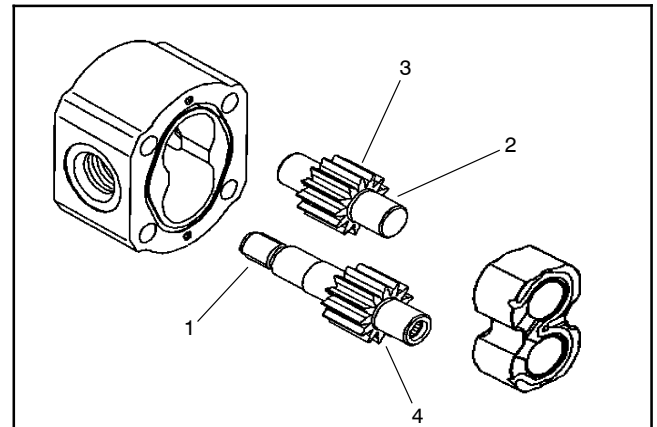

Figure 88

- |                      |                   |
|----------------------|-------------------|
| 1. Gear shaft spline | 3. Gear teeth     |
| 2. Gear shaft        | 4. Gear face edge |

### Assembly (Fig. 86)

**Note:** When assembling the motor, check the marker line on each part to make sure the parts are properly aligned during assembly.

1. Lubricate O-rings, pressure seals, back-up gaskets, and wear plate grooves with a thin coat of petroleum jelly. Lubricate all other internal parts freely with clean hydraulic oil.

2. Install new shaft seal in front plate with seal part number facing out. Seal should be pressed into place until it reaches the bottom of the bore.

3. Install retaining ring into the groove of the front plate.

4. Place front plate, shaft seal side down, on a flat surface.

5. Install the pressure seals, flat side outward, into the grooves in the wear plates. Follow by carefully placing the backup gaskets, flat side outward, between the pressure seals and the grooves in the wear plate.

6. Apply a light coating of petroleum jelly to the exposed side of the front plate.

7. Lubricate the drive gear shaft with clean hydraulic oil. Insert the drive end of the drive shaft through the wear plate with the pressure seal side down and the open side of the pressure seal pointing to the inlet side of the motor. Carefully install shaft into front plate.

8. Lubricate the idler gear shaft with clean hydraulic oil. Install idler gear shaft into the remaining position in the wear plate. Apply a light coating of clean hydraulic oil to gear faces.

9. Install rear wear plate with pressure seal side up and open side of the pressure seal pointing to the inlet side of the motor.

10. Apply a light coating of petroleum jelly to new O-rings and O-ring grooves in the body. Install new O-rings to the body.

11. Install locating dowels in body. Align marker line on the body and front plate.

**IMPORTANT: Do not dislodge seals during installation.**

12. Gently slide the body onto the assembly. Firm hand pressure should be sufficient to engage the dowels.

13. Check to make sure that the surface of the rear wear plate is slightly below the face of the body. If the wear plate is not below the body, check assembly for a shifted pressure seal, backup seal, or O-ring. Correct before proceeding.

14. Apply a light coating of petroleum jelly to the exposed side of the back plate.

15. Place back plate on assembly using marker line for proper location. Firm hand pressure should be sufficient to engage the dowels.

16. Install the four screws and hand tighten.

**IMPORTANT: Avoid using excessive clamping pressure on the motor housing to prevent distorting the housing.**

17. Place mounting flange of the motor into a vise and alternately torque the screws from 38 to 43 ft-lb (51 to 58 N-m).

18. Remove motor from vise.

19. Place a small amount of clean hydraulic oil in the inlet of the motor and rotate the drive shaft away from the inlet one revolution. If any binding is noted, disassemble the pump and check for assembly problems.

## Relief Valve Service

**IMPORTANT: Do not remove the relief valve assembly unless testing shows it to be faulty. The relief valve assembly must be replaced as a complete unit.**

1. When removing or installing the relief valve, motor should be removed from deck and positioned horizontally with the relief valve pointed down (Fig. 89). This process will prevent relief valve from falling into motor passages.

2. Remove plug, O-ring, spring, and relief valve from the backplate. **Do not** attempt to remove the seat from the back plate.

3. Clean and inspect removed parts. Visually inspect relief valve bore and seat in the back plate.

4. Apply hydraulic oil to components. Replace the relief valve assembly: install relief valve, spring, O-ring, and plug into the backplate. Tighten plug.

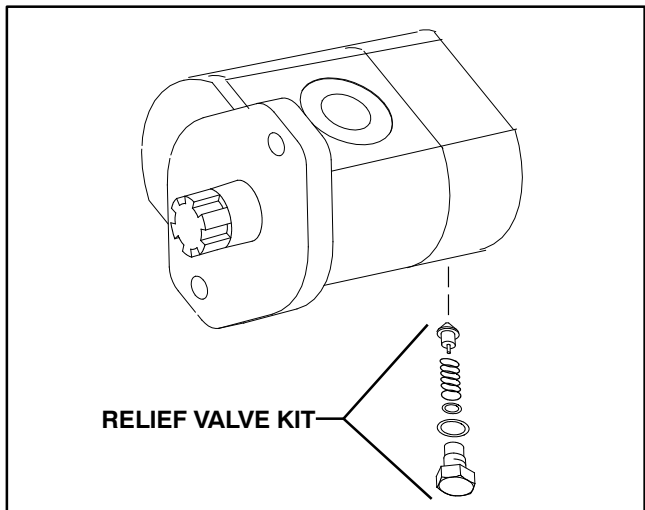

Figure 89

This page is intentionally blank.

## Rotary Cutting Motor Service (Casappa)

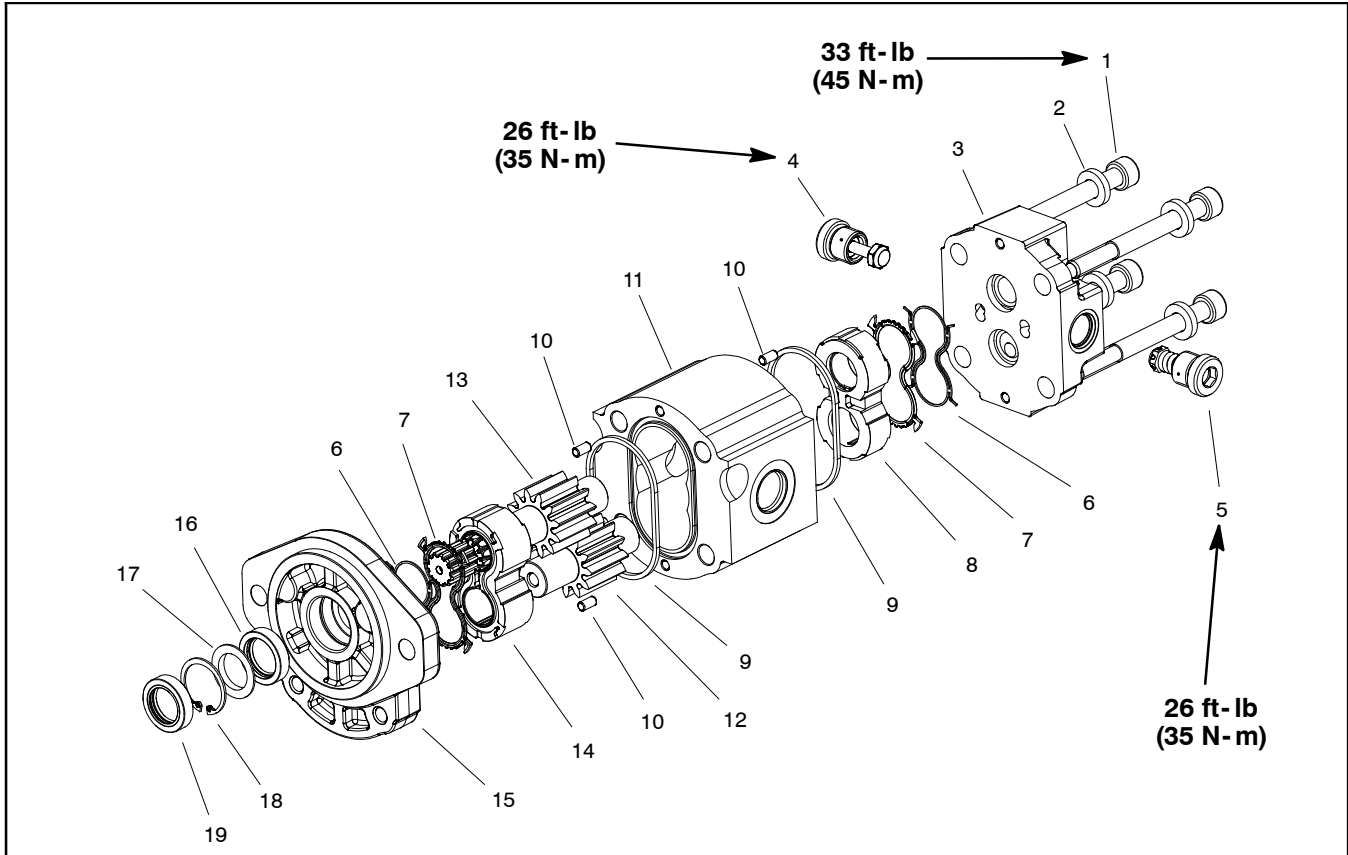

Figure 90

- |                               |                        |                      |
|-------------------------------|------------------------|----------------------|
| 1. Socket head screw (4 used) | 8. Rear wear plate     | 14. Front wear plate |
| 2. Washer (4 used)            | 9. O-ring              | 15. Front plate      |
| 3. Back plate                 | 10. Dowel pin (4 used) | 16. Shaft seal       |
| 4. Anti-cavitation valve      | 11. Body               | 17. Washer           |
| 5. Relief valve               | 12. Idler gear         | 18. Retaining ring   |
| 6. Pressure seal              | 13. Drive gear         | 19. Seal             |
| 7. Back up gasket             |                        |                      |

For service procedures of a Casappa motor, refer to Disassembly, Inspection and Assembly steps listed in Rotary Cutting Motor Service (Haldex). Refer to Figure 90 for torque specifications.

This page is intentionally blank.

# Hydraulic Manifold

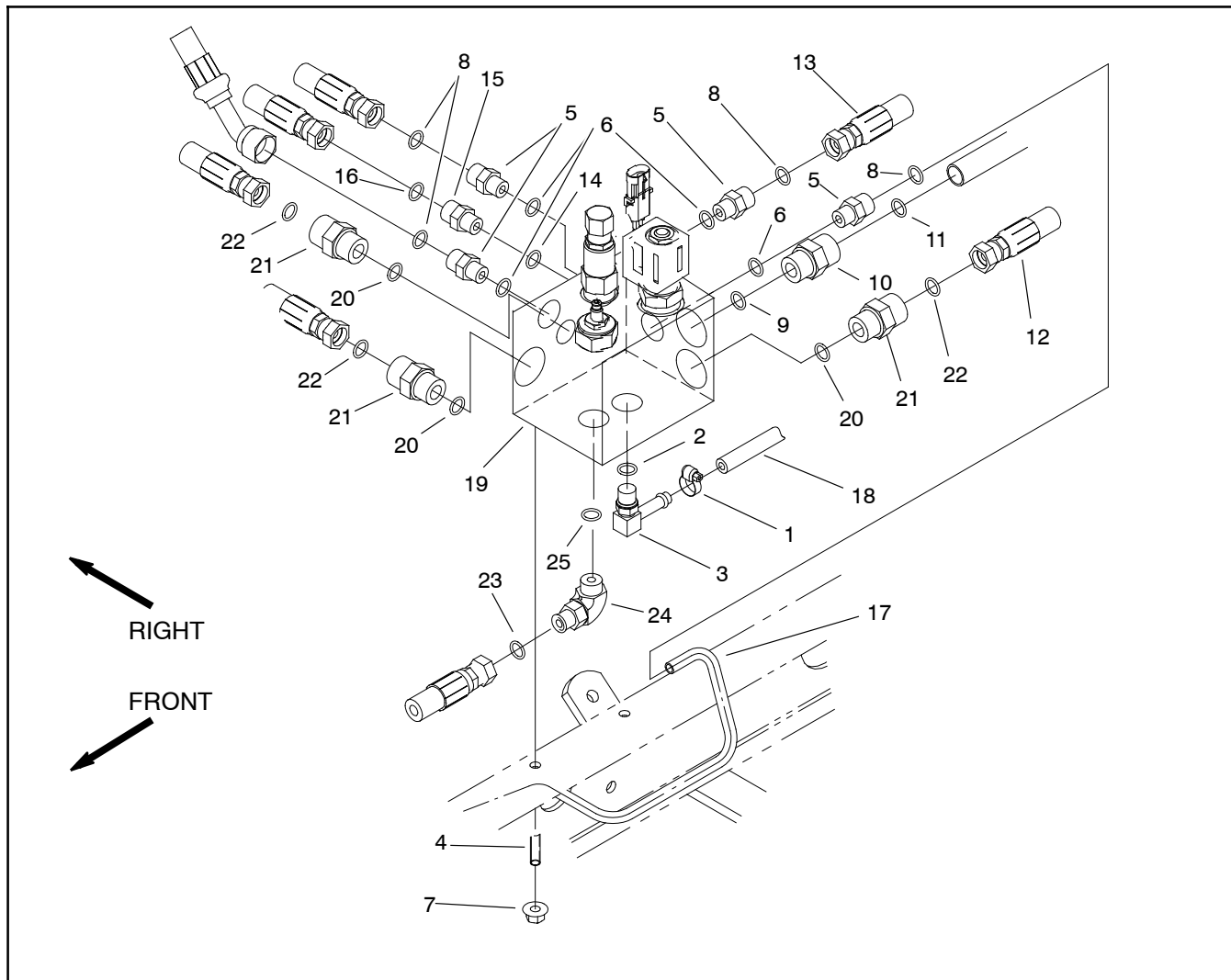

Figure 91

- |                               |                                |                                |
|-------------------------------|--------------------------------|--------------------------------|
| 1. Hose clamp                 | 10. Straight hydraulic fitting | 18. Hydraulic hose             |
| 2. O-ring                     | 11. O-ring                     | 19. Hydraulic manifold         |
| 3. Barb fitting               | 12. Hydraulic hose             | 20. O-ring                     |
| 4. Stud                       | 13. Hydraulic hose             | 21. Straight hydraulic fitting |
| 5. Straight hydraulic fitting | 14. Straight hydraulic fitting | 22. O-ring                     |
| 6. O-ring                     | 15. O-ring                     | 23. O-ring                     |
| 7. Flange head nut            | 16. O-ring                     | 24. 90° hydraulic fitting      |
| 8. O-ring                     | 17. Hydraulic tube             | 25. O-ring                     |
| 9. O-ring                     |                                |                                |

## Removal (Fig. 91)

**Note:** The ports on the manifold are marked for easy identification of components. Example: BV is the deck circuit braking valve and P1 is the gear pump connection port. (See Hydraulic Schematics to identify the function of the hydraulic lines and cartridge valves at each port location).

1. Clean hydraulic manifold before doing any disassembly.
2. Label all hydraulic connections for assembly purposes.

 <b>WARNING</b>
<b>Before disconnecting or performing any work on the hydraulic system, all pressure in the system must be relieved. See Relieving Hydraulic System Pressure in the General Information section.</b>

3. Remove hydraulic manifold from the machine using Figure 91 as guide.
4. If hydraulic fittings are to be removed from manifold, mark fitting orientation to allow correct assembly.

## Installation (Fig. 91)

1. If hydraulic fittings were removed from manifold, install fittings to manifold using marks made during the removal process to properly orientate fittings.
2. Install hydraulic manifold to the frame using Figure 91 as guide.
3. Make sure hydraulic tank is full. Add correct oil if necessary (see Check Hydraulic System Fluid).

## Hydraulic Manifold Service (Serial Numbers Below 24000600)

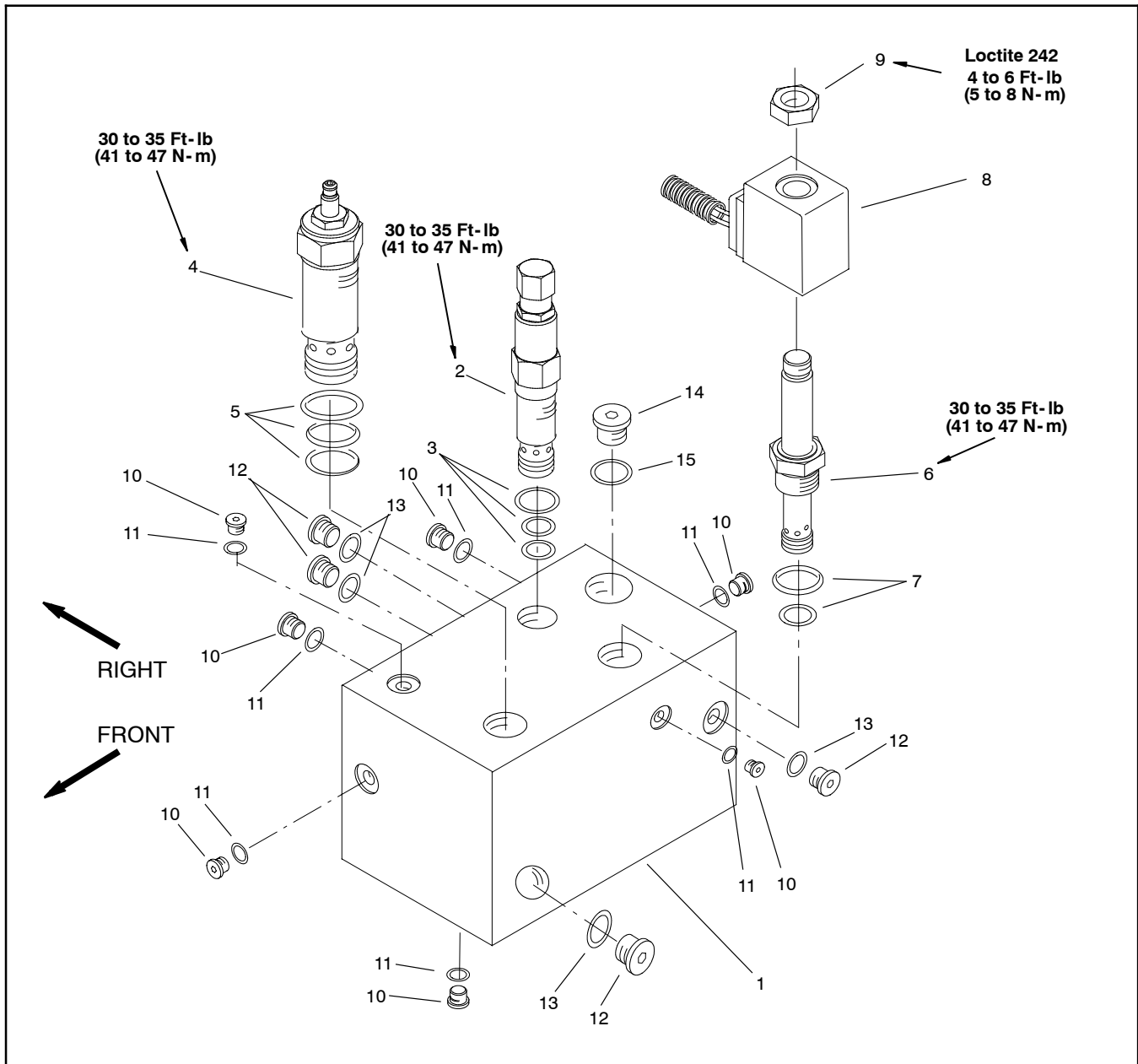

Figure 92

- |                                 |                             |                  |
|---------------------------------|-----------------------------|------------------|
| 1. Manifold body                | 6. SRV cartridge valve (R1) | 11. O-ring       |
| 2. Logic cartridge valve (LC1)  | 7. Seal kit                 | 12. Plug (SAE-4) |
| 3. Seal kit                     | 8. SRV coil                 | 13. O-ring       |
| 4. Braking cartridge valve (BV) | 9. Nut                      | 14. Plug (SAE-8) |
| 5. Seal kit                     | 10. Plug (SAE-2)            | 15. O-ring       |

**Note:** The ports on the manifold are marked for easy identification of components. Examples: BV is the deck circuit braking valve and P1 is the gear pump connection port. (See Hydraulic Schematics to identify the function of the hydraulic lines and cartridge valves at each port location).

### SRV Cartridge Valve (Fig. 92 and 93)

1. Make sure the manifold is clean before removing the cartridge valve.

Hydraulic System (Rev. G)

2. Remove nut securing solenoid to the SRV cartridge valve. Slide solenoid off the valve.

**IMPORTANT: Use care when handling the cartridge valve. Slight bending or distortion of the stem tube can cause binding and malfunction.**

3. Remove SRV cartridge valve from port R1 using a deep socket wrench.



4. Visually inspect the port in the manifold for damage to the sealing surfaces, damaged threads, or contamination.

5. Visually inspect cartridge valve for damaged sealing surfaces or contamination.

A. Contamination may cause valves to stick or hang up. Contaminants can become lodged in small valve orifices or seal areas causing malfunction.

B. If valve sealing surfaces appear pitted or damaged, the hydraulic system may be overheating or there may be water in the system.

	<b>CAUTION</b>
<b>Use eye protection such as goggles when using compressed air.</b>	

6. Clean cartridge valve using clean mineral spirits. Submerge valve in clean mineral spirits to flush out contamination. Use a probe (wood dowel or brass drift) to push the internal spool in and out 20 to 30 times to flush out contamination. Particles as fine as talcum powder can affect the operation of high pressure hydraulic valves. Use compressed air for cleaning.

**IMPORTANT: Use care when handling the cartridge valve. Slight bending or distortion of the stem tube can cause binding and malfunction.**

7. Reinstall the SRV cartridge valve:

A. Lubricate new O-rings of seal kit with clean hydraulic oil and install. The O-rings must be arranged properly on the cartridge valve for proper operation and sealing (Fig. 94).

B. Thread valve carefully into port R1. The valve should go in easily without binding.

C. Torque cartridge valve using a deep socket from 30 to 35 ft-lb (41 to 47 N-m).

D. Install solenoid coil to the cartridge valve. Apply "Loctite 242" or equivalent to the threads of the valve. Torque nut from 4 to 6 ft-lb (5 to 8 N-m).

8. If problems still exist, remove valve and clean again or replace valve.

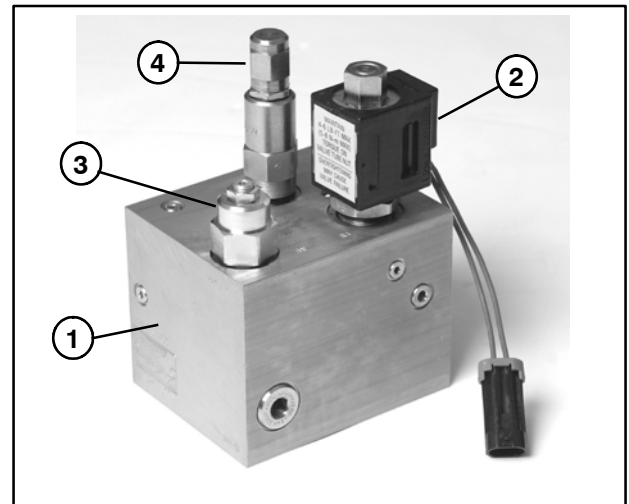

Figure 93

- |                             |                       |
|-----------------------------|-----------------------|
| 1. Manifold assembly        | 3. Braking valve (BV) |
| 2. SRV cartridge valve (R1) | 4. Logic valve (LC1)  |

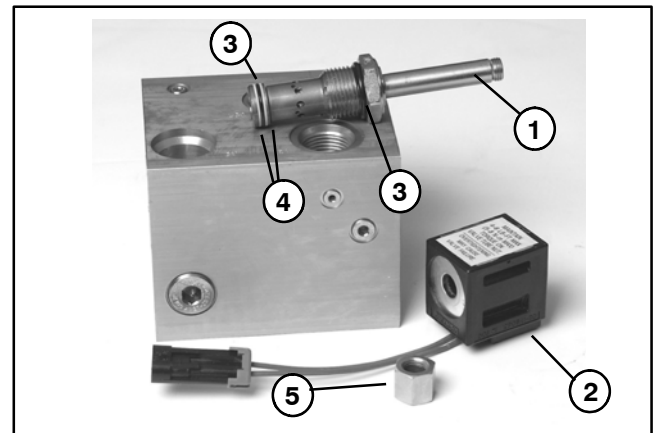

Figure 94

- |                        |                          |
|------------------------|--------------------------|
| 1. SRV cartridge valve | 4. Seal kit backup rings |
| 2. Solenoid coil       | 5. Solenoid nut          |
| 3. Seal kit O-rings    |                          |

## Braking and Logic Cartridge Valves (Fig. 92 and 93)

1. Make sure manifold is clean before removing the cartridge.

**IMPORTANT: Use care when handling the cartridge valve. Slight bending or distortion of the stem tube can cause binding and malfunction.**

2. Remove cartridge valve using a deep socket wrench. **Note:** Do not loosen locknut on top of valve.

3. Visually inspect port in the manifold for damage to the sealing surfaces, damaged threads, or contamination.

4. Visually inspect cartridge valve for damaged sealing surfaces or contamination.

A. Contamination may cause valves to stick or hang up. Contaminates can become lodged in small valve orifices or seal areas causing malfunction.

B. If sealing surfaces appear pitted or damaged, the hydraulic system may be overheating or there may be water in the system.



## CAUTION

Use eye protection such as goggles when using compressed air.

5. Clean cartridge valve using clean mineral spirits. Submerge valve in clean mineral spirits to flush out contamination. Particles as fine as talcum powder can affect the operation of high pressure hydraulic valves. Use compressed air for cleaning.

**IMPORTANT: Use care when handling the cartridge valve. Slight bending or distortion of the stem tube can cause binding and malfunction.**

6. Reinstall cartridge valve:

A. Lubricate new O-rings and backup rings of seal kit with clean hydraulic oil and install. The O-rings and backup rings must be arranged properly on the cartridge valve for proper operation and sealing (Figs. 95 and 96).

B. Thread cartridge valve carefully into the applicable port (Fig. 92). The valve should go in easily without binding. Torque valve to 30 to 35 ft-lb (41 to 47 N-m).

C. If problems still exist, remove valve and clean again or replace valve.

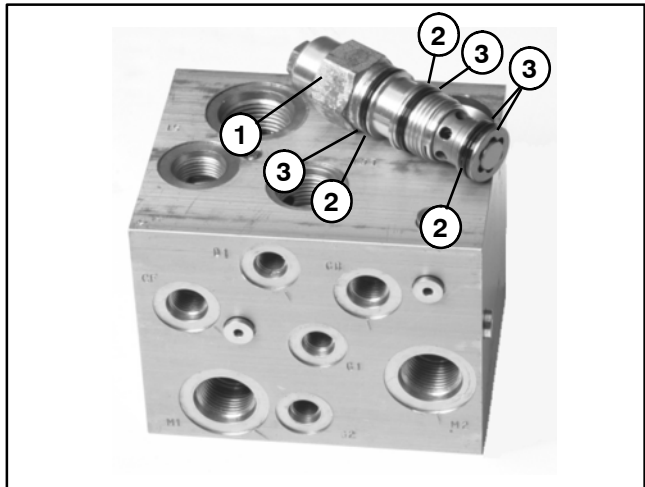

Figure 95

- 1. Braking cartridge valve
- 2. Seal kit O-rings
- 3. Seal kit backup rings

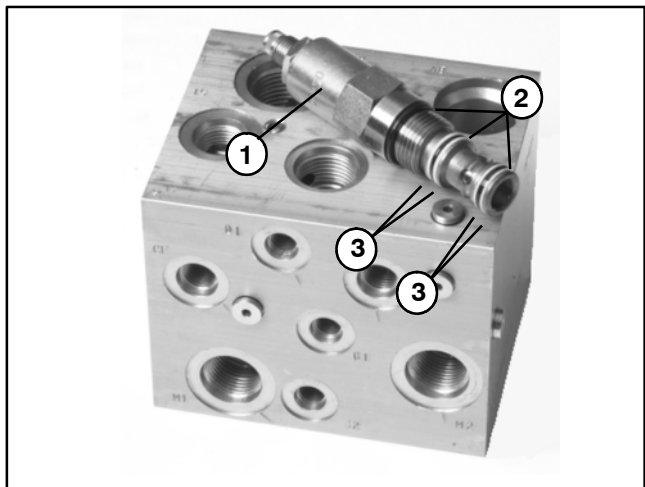

Figure 96

- 1. Logic cartridge valve
- 2. Seal kit O-rings
- 3. Seal kit backup rings

This page is intentionally blank.

# Hydraulic Manifold Service (Serial Numbers 240000601 to 313999999)

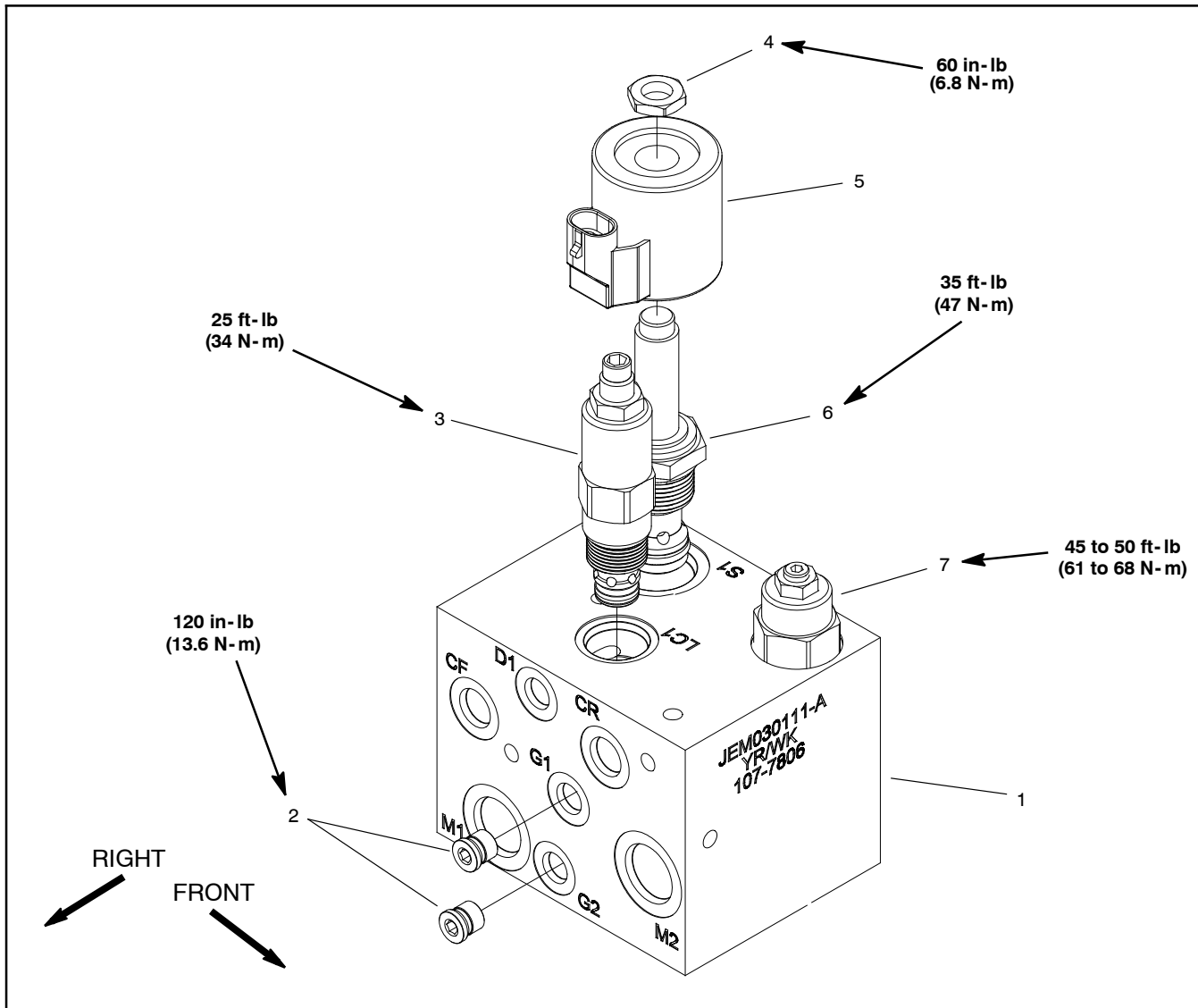

Figure 97

- |                                |                  |                                  |
|--------------------------------|------------------|----------------------------------|
| 1. Manifold body               | 4. Nut           | 6. Solenoid cartridge valve (R1) |
| 2. NWD #4 plug                 | 5. Solenoid coil | 7. Braking cartridge valve (BV)  |
| 3. Logic cartridge valve (LC1) |                  |                                  |

**NOTE:** The ports on the manifold are marked for easy identification of components. Examples: BV is the deck circuit braking valve and P1 is the gear pump connection port (see Hydraulic Schematic to identify the function of the hydraulic lines and cartridge valves at each port location).

**NOTE:** The Groundsmaster 3500-D hydraulic manifold uses several zero leak plugs. These plugs have a tapered sealing surface on the plug head that is designed to resist vibration induced plug loosening. The zero leak plugs also have an O-ring as a secondary seal. If zero leak plug removal is necessary, lightly rap the plug head using a punch and hammer before using an allen wrench to remove the plug; the impact will allow plug removal with less chance of damage to the socket head of the plug.

### Cartridge Valve Service (Fig. 97)

1. Make sure the manifold is clean before removing the valve.
2. If cartridge is solenoid operated, remove nut securing solenoid to the cartridge valve. Carefully slide solenoid coil off the valve.

**IMPORTANT: Use care when handling the cartridge valve. Slight bending or distortion of the stem tube can cause binding and malfunction.**

3. Remove cartridge valve with a deep socket wrench. Note correct location for O-rings, sealing rings and backup rings. Remove and discard seal kit.
4. Visually inspect the port in the manifold for damage to the sealing surfaces, damaged threads or contamination.
5. Visually inspect cartridge valve for damaged sealing surfaces and contamination.
  - A. Contamination may cause valves to stick or hang up. Contamination can become lodged in small valve orifices or seal areas causing malfunction.
  - B. If valve sealing surfaces appear pitted or damaged, the hydraulic system may be overheating or there may be water in the system.



## CAUTION

Use eye protection such as goggles when using compressed air.

6. Clean cartridge valve using clean mineral spirits. Submerge valve in clean mineral spirits to flush out contamination. Particles as fine as talcum powder can affect the operation of high pressure hydraulic valves. Be extremely careful not to damage cartridge. Use compressed air for cleaning.

7. Reinstall the cartridge valve into the manifold block:

- A. Lubricate new seal kit components with clean hydraulic oil and install on valve. The O-rings, sealing rings and backup rings must be arranged properly on the cartridge valve for proper operation and sealing.

**IMPORTANT: Use care when handling the valve cartridge. Slight bending or distortion of the stem tube can cause binding and malfunction.**

- B. Thread cartridge valve carefully into manifold port. The valve should go in easily without binding.

- C. Torque cartridge valve using a deep socket to valve identified in manifold illustration (Fig. 97).

- D. If cartridge is solenoid operated, carefully install solenoid coil to the cartridge valve. Torque nut to valve identified in manifold illustration (Fig. 97).

8. If problems still exist, remove valve and clean again or replace valve.

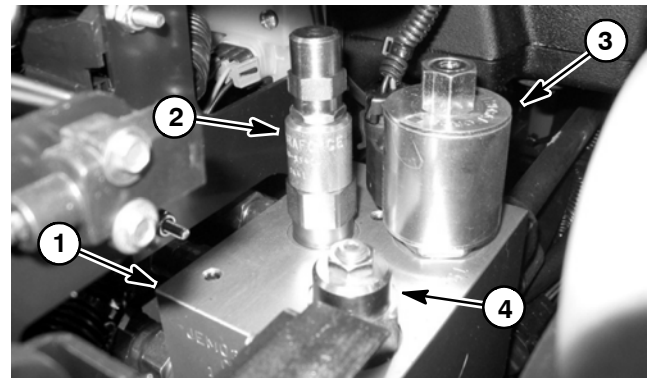

Figure 98

- |                      |                        |
|----------------------|------------------------|
| 1. Manifold assembly | 3. Solenoid valve (R1) |
| 2. Logic valve (LC1) | 4. Braking valve (BV)  |

## Hydraulic Manifold Service (Serial Numbers Above 31400000)

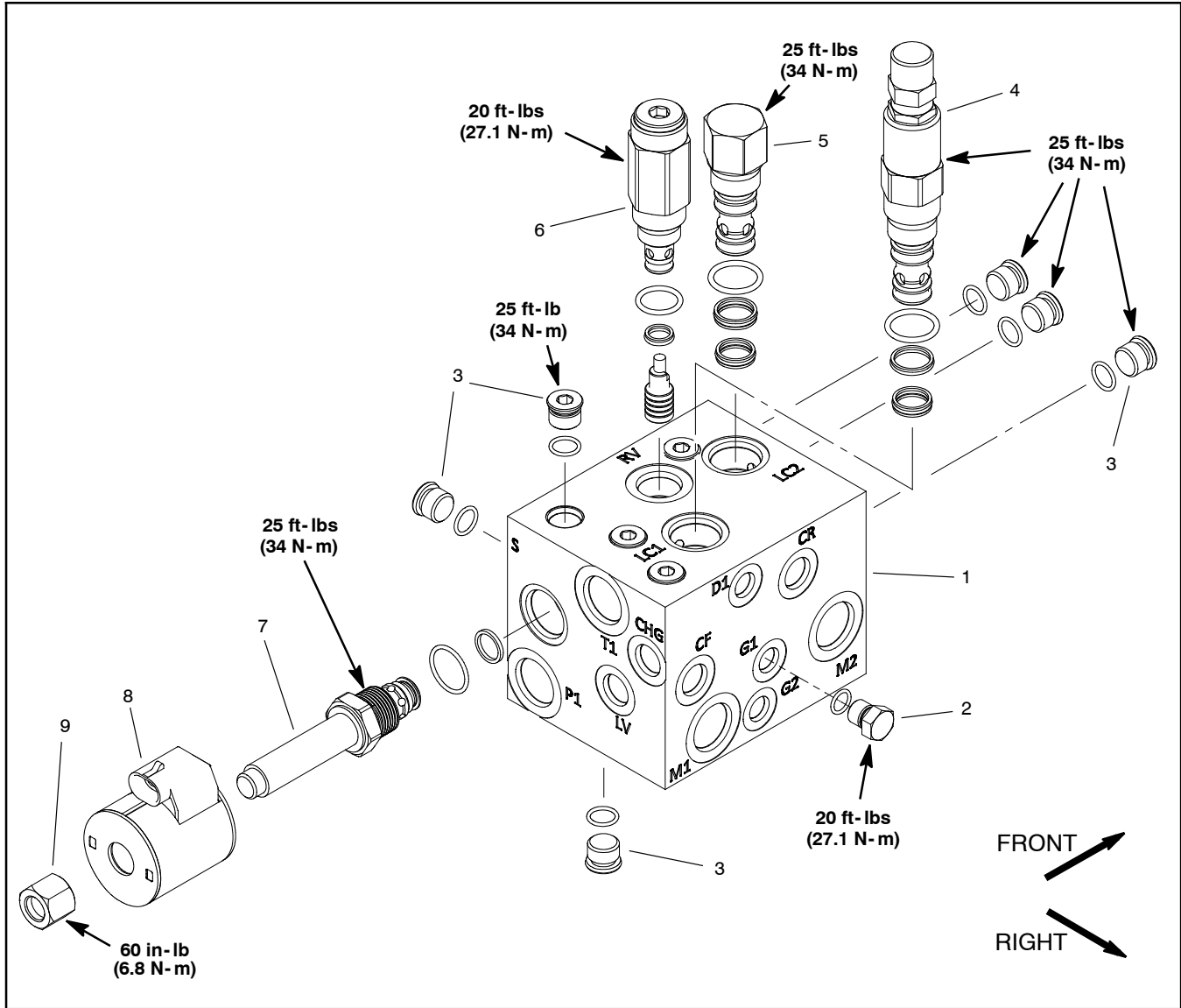

Figure 99

- |                      |                                |                                 |
|----------------------|--------------------------------|---------------------------------|
| 1. Manifold body     | 4. Logic cartridge valve (LC1) | 7. Solenoid cartridge valve (S) |
| 2. #4 Hex head plug  | 5. Logic cartridge valve (LC2) | 8. Solenoid coil                |
| 3. #4 Zero leak plug | 6. Relief valve (RV)           | 9. Nut                          |

**NOTE:** The ports on the manifold are marked for easy identification of components. Examples: RV is the deck circuit braking valve and P1 is the gear pump connection port (see Hydraulic Schematic to identify the function of the hydraulic lines and cartridge valves at each port location).

**NOTE:** The Groundsmaster 3500-D hydraulic manifold uses several zero leak plugs. These plugs have a tapered sealing surface on the plug head that is designed to resist vibration induced plug loosening. The zero leak plugs also have an O-ring as a secondary seal. If zero leak plug removal is necessary, lightly rap the plug head using a punch and hammer before using an allen wrench to remove the plug: the impact will allow plug removal with less chance of damage to the socket head of the plug.

For hydraulic manifold service procedures, refer to Hydraulic Manifold Service (Serial Numbers 240000601 to 313999999) in this section. Refer to Figure 99 for cartridge valve and plug installation torque.

# Control Valve

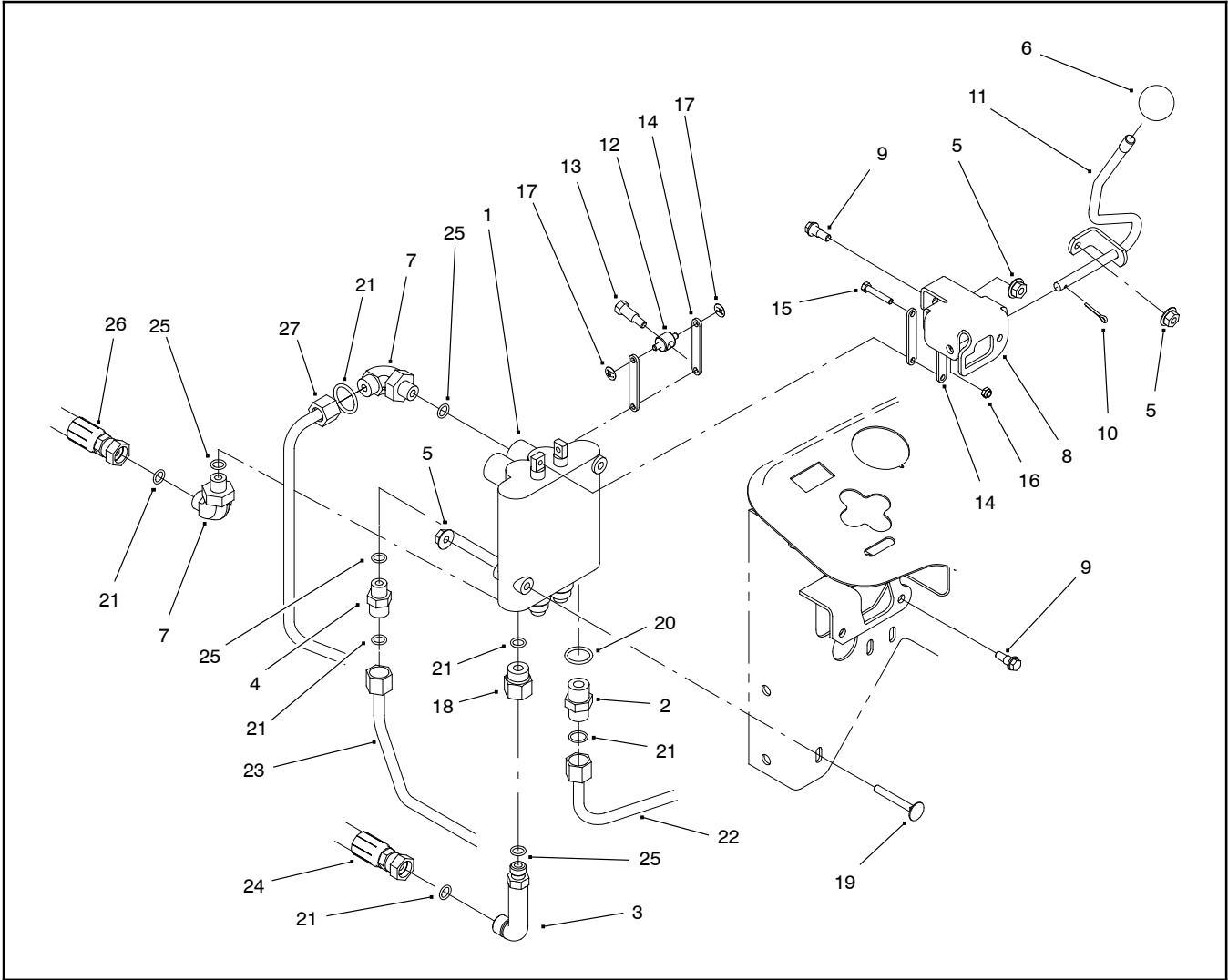

Figure

- |                                 |                             |                    |
|---------------------------------|-----------------------------|--------------------|
| 1. Control valve (2-spool)      | 10. Cotter pin 100          | 19. Carriage screw |
| 2. Hydraulic fitting (straight) | 11. Valve lever             | 20. O-ring         |
| 3. 90° hydraulic fitting        | 12. Valve actuator trunnion | 21. O-ring         |
| 4. Hydraulic fitting (straight) | 13. Shoulder bolt           | 22. Hydraulic tube |
| 5. Flange nut                   | 14. Link                    | 23. Hydraulic tube |
| 6. Knob                         | 15. Bolt                    | 24. Hydraulic hose |
| 7. 90° hydraulic fitting        | 16. Lock nut                | 25. O-ring         |
| 8. Valve actuator bracket       | 17. Push nut                | 26. Hydraulic hose |
| 9. Shoulder bolt                | 18. Hydraulic fitting       | 27. Hydraulic tube |



## Removal



### WARNING

Before disconnecting or performing any work on the hydraulic system, all pressure in the system must be relieved. See Relieving Hydraulic System Pressure in the General Information section.

1. Remove control valve from the frame using Figures 100 and 101 as guides.
2. If hydraulic fittings are to be removed from control valve, mark fitting orientation to allow correct assembly.

## Installation

1. If hydraulic fittings were removed from control valve, install fittings to valve using marks made during the removal process to properly orientate fittings.
2. Install control valve to the frame using Figures 100 and 101 as guides.
3. Make sure hydraulic tank is full. Add correct oil if necessary (see Check Hydraulic System Fluid).

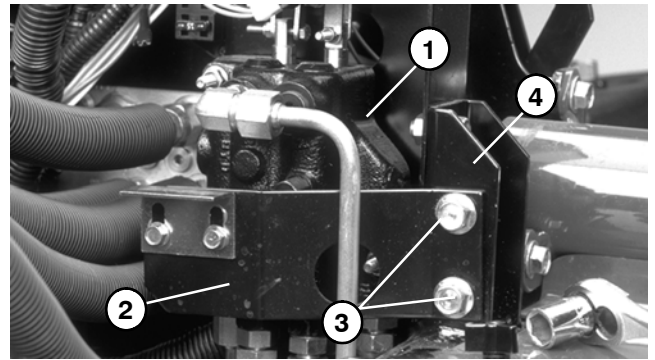
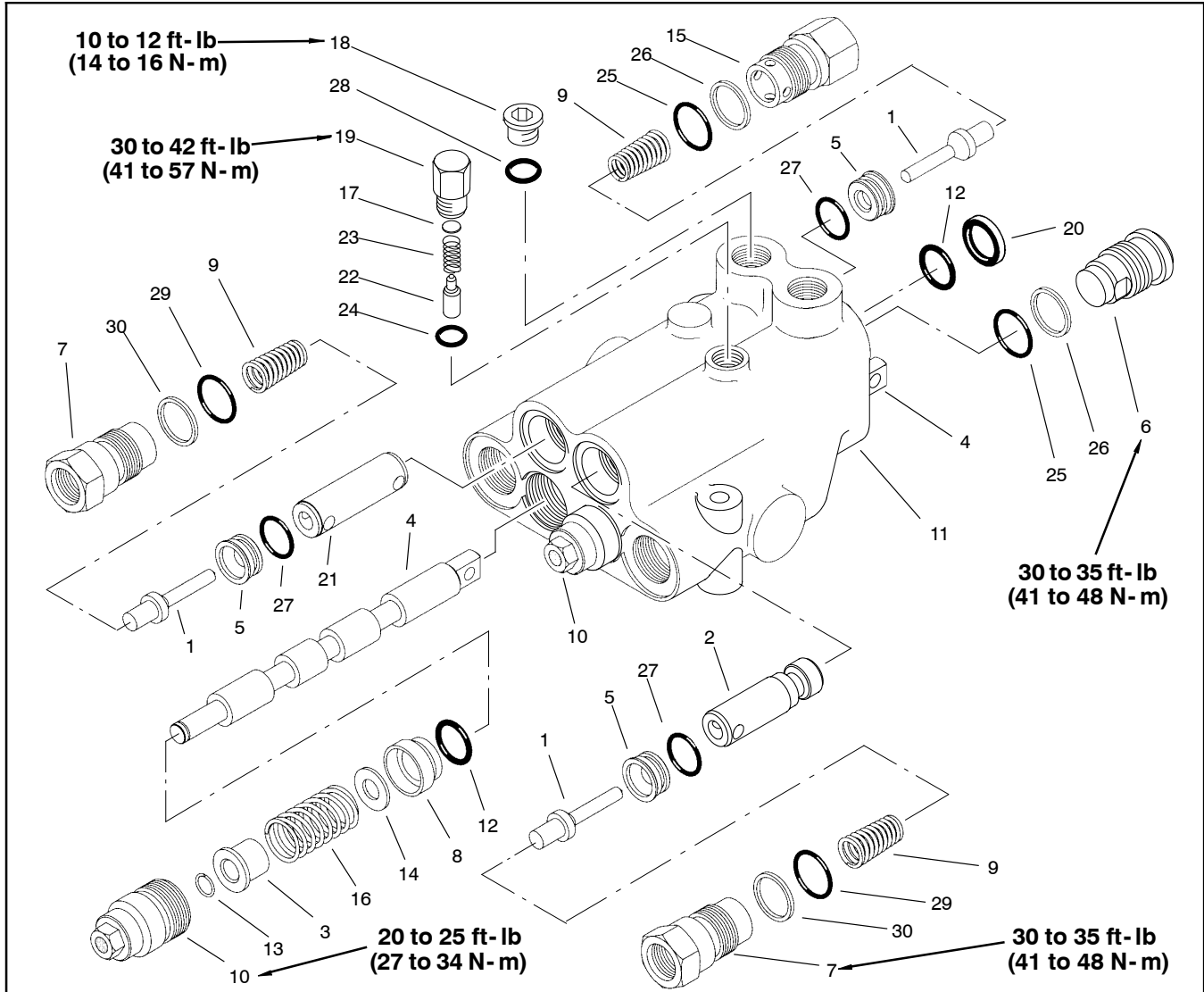

Figure 101

- |                    |                       |
|--------------------|-----------------------|
| 1. Spool valve     | 3. Flange head screws |
| 2. Support bracket | 4. Frame              |

# Control Valve Service



Figure

- |                                  |                         |                    |
|----------------------------------|-------------------------|--------------------|
| 1. Check poppet                  | 11. Valve body 102      | 21. Plunger        |
| 2. Grooved plunger               | 12. O-ring              | 22. Plunger detent |
| 3. Spacer                        | 13. Retaining ring      | 23. Detent spring  |
| 4. Spool                         | 14. Washer              | 24. O-ring         |
| 5. Seat                          | 15. Seat retaining plug | 25. O-ring         |
| 6. Solid plug                    | 16. Spool spring        | 26. Back-up washer |
| 7. Seat retaining plug with port | 17. Disc                | 27. O-ring         |
| 8. Bushing                       | 18. Plug                | 28. O-ring         |
| 9. Check spring                  | 19. Detent plug         | 29. O-ring         |
| 10. Spool cap                    | 20. Wiper seal          | 30. Back-up washer |

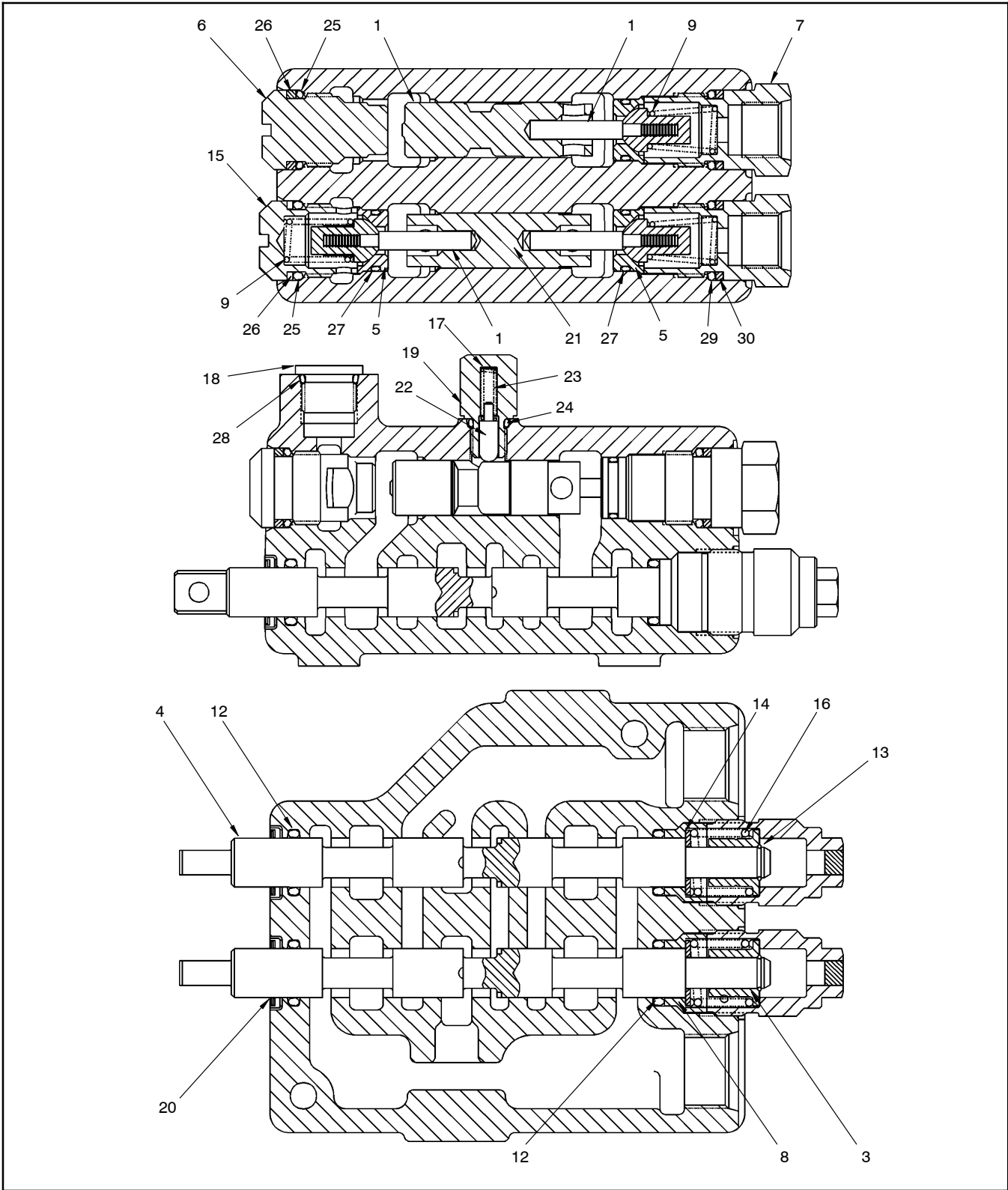

Figure

- |                                  |                         |                    |
|----------------------------------|-------------------------|--------------------|
| 1. Check poppet                  | 11. Valve body 103      | 21. Plunger        |
| 2. Grooved plunger               | 12. O-ring              | 22. Plunger detent |
| 3. Spacer                        | 13. Retaining ring      | 23. Detent spring  |
| 4. Spool                         | 14. Washer              | 24. O-ring         |
| 5. Seat                          | 15. Seat retaining plug | 25. O-ring         |
| 6. Solid plug                    | 16. Spool spring        | 26. Back-up washer |
| 7. Seat retaining plug with port | 17. Disc                | 27. O-ring         |
| 8. Bushing                       | 18. Plug                | 28. O-ring         |
| 9. Check spring                  | 19. Detent plug         | 29. O-ring         |
| 10. Spool cap                    | 20. Wiper seal          | 30. Back-up washer |

## Disassembly

1. Plug all ports and clean the outside of the valve thoroughly.

**IMPORTANT: Match- mark spools to their associated bores before disassembly. Spools must be reinstalled to the bore from which they were removed.**

2. Remove both spool caps and slide the spool assemblies from their bores.
3. Remove O-ring and bushing from each spool assembly.
4. Remove wiper seals and O-rings from the spool bore ends that are opposite the spool caps.

**Note:** Disassemble spool assemblies only if the retaining ring, spacer, spring, or washer need replacing.

5. Remove seat retaining plugs, back-up washers, O-rings, and check springs from the valve body.
6. Remove check poppets, seats, O-rings, and plungers from the valve body.
7. Remove solid plug, back-up washer, and O-ring from the opposite end of the plunger.
8. Remove plug and O-ring from the top of the valve body next to the detent plug.
9. Remove detent plug and O-ring from the valve body. Remove disc, spring, and detent plunger from the body.

## Inspection

1. Inspect spools and spool bores for wear. If wear is excessive, replace valve with new one.
2. Inspect springs and replace as necessary.
3. Inspect plunger, detent plunger, and check poppet for wear. Replace as necessary.
4. Inspect seat, spacer, and bushing for wear. Replace as necessary.
5. Inspect disc and washer. Replace as necessary.
6. Inspect cap and plugs for damaged threads and inspect O-ring sealing surfaces. Replace as necessary.

## Assembly

**IMPORTANT: Do not wipe parts with dry paper towels or rags. Lint may cause damage to the hydraulic system.**



## CAUTION

**Use eye protection such as goggles when using compressed air.**

1. Clean all metal parts with solvent and blow dry with compressed air.
2. Replace check poppets, O-rings, and back-up washers with new ones.
3. Install new O-rings into the valve body.
4. Slide bushings and new O-rings over the spools.
5. If a spool was disassembled, install washer, spool spring, spacer, and retaining ring to the spool.
6. Lubricate spools liberally with clean hydraulic fluid and install into their proper bore.
7. Install spool caps into valve body. Torque caps from 20 to 25 ft-lb (27 to 34 N-m).
8. Lubricate both plungers liberally with clean hydraulic fluid and install into their proper bore.
9. Install new O-rings, seats, check poppets, and check springs into the plunger bores.
10. Install O-rings, back-up washers, and seat retaining plugs into their plunger bores. Torque both plugs from 30 to 35 ft-lb (41 to 48 N-m).
11. Install new O-ring, back-up washer, and solid plug into the bore with the grooved plunger. Torque plug from 30 to 35 ft-lb (41 to 48 N-m).
12. Install new O-ring, seat, check poppet, check spring, new O-ring, back-up washer, and seat retaining plug into the bore with the plunger. Torque plug from 30 to 35 ft-lb (41 to 48 N-m).
13. Install O-ring and plug into the top of the valve body next to the detent plug bore. Torque plug from 10 to 12 ft-lb (14 to 16 N-m).
14. Lubricate plunger detent, spring, and disc liberally with clean hydraulic fluid and install into its valve body bore.
15. Install O-ring and detent plug into its proper bore. Torque plug from 30 to 42 ft-lb (41 to 57 N-m).

This page is intentionally blank.

# Piston Pump

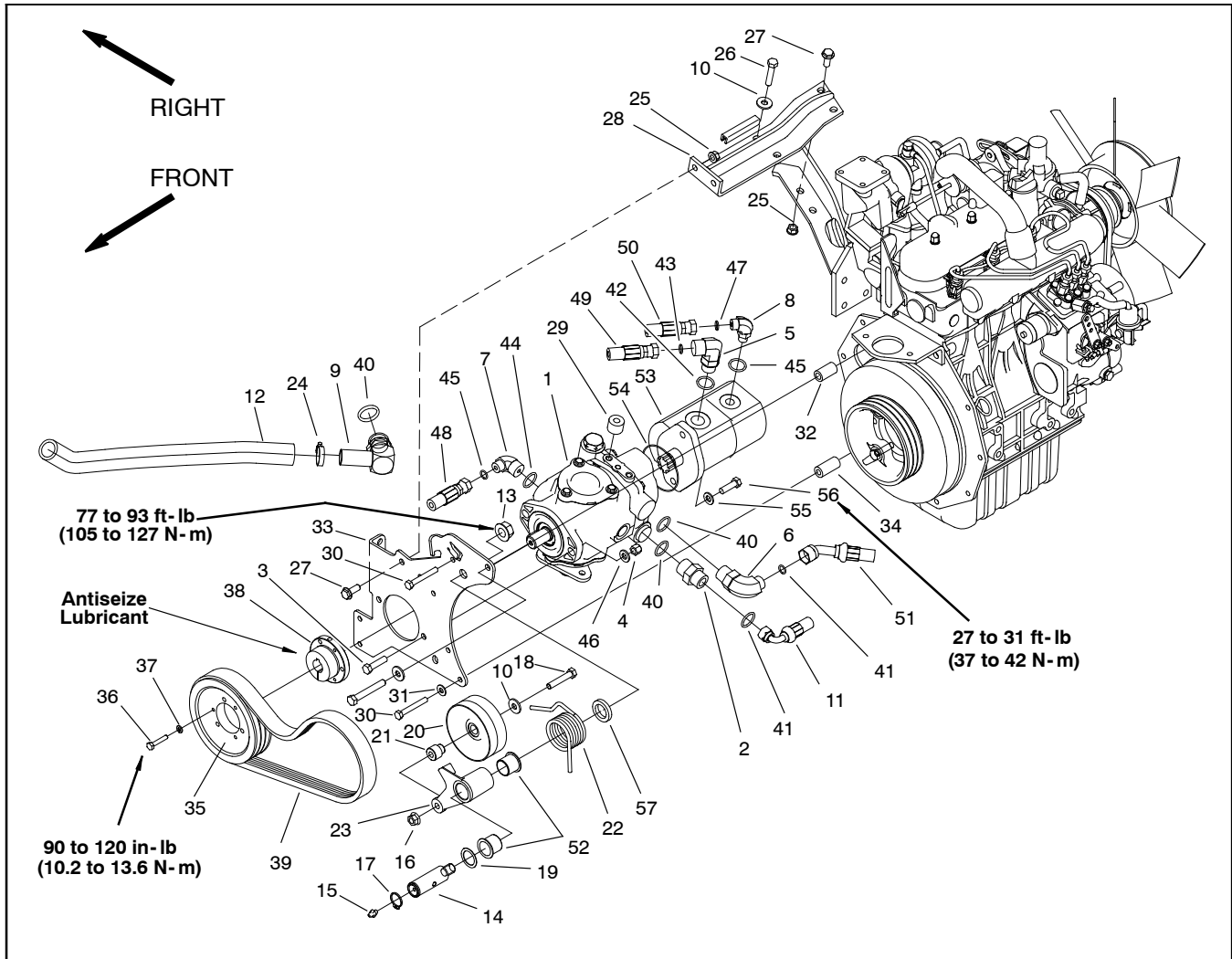

Figure 104

- |                               |                        |                       |
|-------------------------------|------------------------|-----------------------|
| 1. Piston pump                | 20. Idler pulley       | 39. V-belt            |
| 2. Straight hydraulic fitting | 21. Spacer             | 40. O-ring            |
| 3. Cap screw                  | 22. Torsion spring     | 41. O-ring            |
| 4. Lock nut                   | 23. Idler arm          | 42. O-ring            |
| 5. 90° hydraulic fitting      | 24. Hose clamp         | 43. O-ring            |
| 6. 90° hydraulic fitting      | 25. Flange nut         | 44. O-ring            |
| 7. 90° hydraulic fitting      | 26. Cap screw          | 45. O-ring            |
| 8. 90° hydraulic fitting      | 27. Flange head screw  | 46. Flat washer       |
| 9. 90° hydraulic fitting      | 28. Pump support       | 47. O-ring            |
| 10. Washer                    | 29. Spacer             | 48. Hydraulic hose    |
| 11. Hydraulic hose            | 30. Cap screw          | 49. Hydraulic hose    |
| 12. Suction hose              | 31. Flat washer        | 50. Hydraulic hose    |
| 13. Flange nut                | 32. Spacer             | 51. Hydraulic hose    |
| 14. Idler pivot pin           | 33. Pump mount plate   | 52. Bushing           |
| 15. Grease fitting            | 34. Pump mount spacer  | 53. Gear pump         |
| 16. Flange nut                | 35. Pulley             | 54. O-ring            |
| 17. Retaining ring            | 36. Cap screw          | 55. Flat washer       |
| 18. Cap screw                 | 37. Lock washer        | 56. Socket head screw |
| 19. Thrust washer             | 38. Taper lock bushing | 57. Idler arm spacer  |

## Neutral Arm Assembly

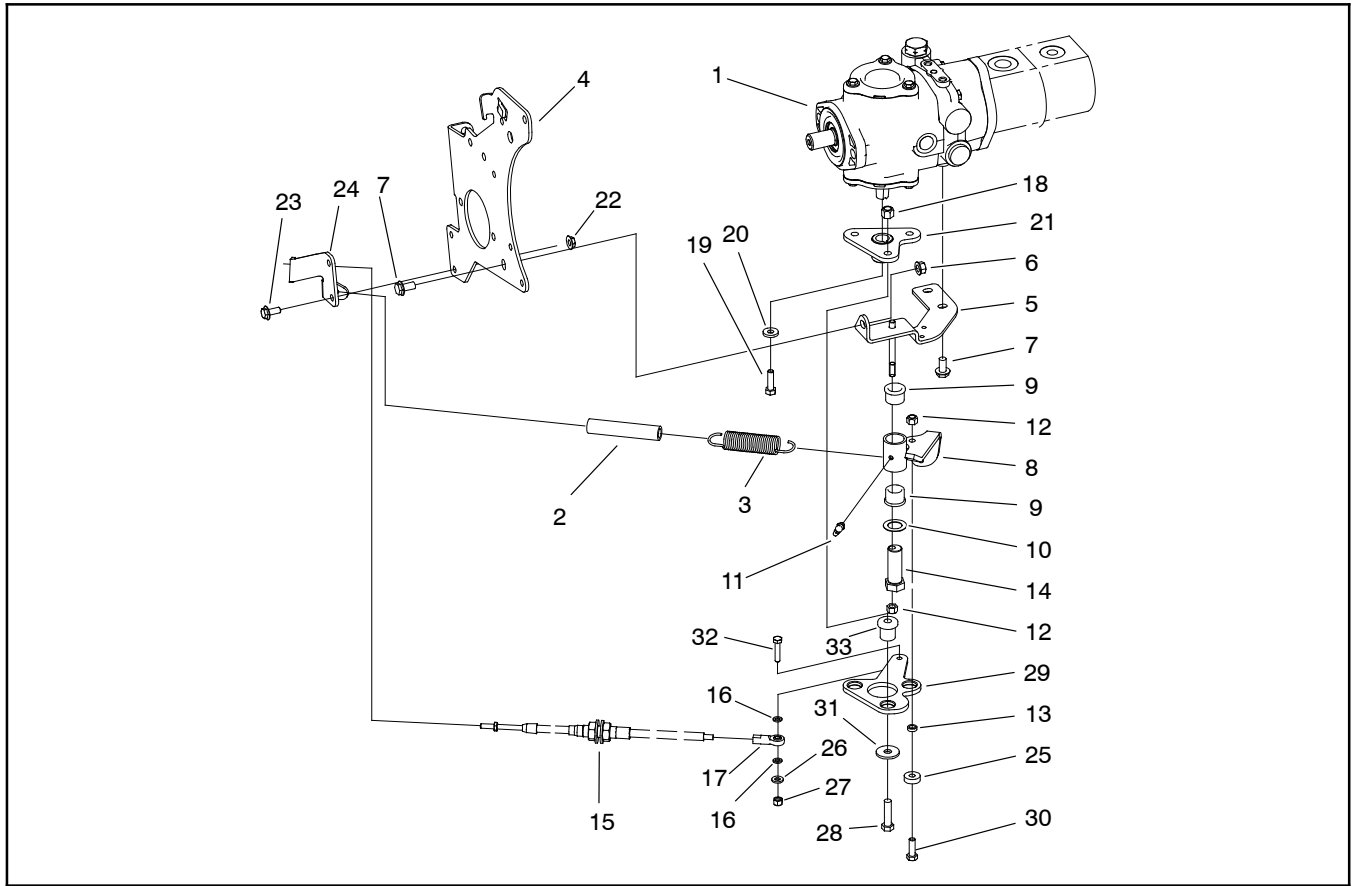

Figure  
105

- |                        |                            |                           |
|------------------------|----------------------------|---------------------------|
| 1. Pump assembly       | 12. Lock nut               | 23. Flange head screw     |
| 2. Hose                | 13. Spacer                 | 24. Cable support bracket |
| 3. Extension spring    | 14. Traction stud          | 25. Ball bearing          |
| 4. Pump mount plate    | 15. Traction control cable | 26. Flat washer           |
| 5. Neutral bracket     | 16. Flat washer            | 27. Lock nut              |
| 6. Flange nut          | 17. Ball joint             | 28. Cap screw             |
| 7. Flange head screw   | 18. Lock nut               | 29. Pump lever            |
| 8. Neutral arm         | 19. Cap screw              | 30. Cap screw             |
| 9. Flange bushing      | 20. Flat washer            | 31. Flat washer           |
| 10. Thrust washer      | 21. Hub assembly           | 32. Cap screw             |
| 11. 90° grease fitting | 22. Flange nut             | 33. Mount                 |

### Piston Pump Removal (Fig. 104 & 105)

1. Remove traction belt from the pulley (see Replace Traction Belt).
2. Remove neutral arm assembly from the piston pump as follows:



## CAUTION

The extension spring is under tension and may cause personal injury during removal. Use caution when removing spring from the pump lever.

A. Remove extension spring from the cable support bracket and neutral arm.

B. Disconnect traction control cable from the pump lever.

C. Remove both flange head screws securing the neutral bracket to the piston pump. Remove flange nut and flange head screw securing the neutral bracket to the pump mount plate.

D. Remove cap screw and flat washer securing the pump lever to the piston pump trunnion.

E. Separate pump lever from pump trunnion and neutral bracket from mount plate.

3. Drain hydraulic oil from hydraulic tank (see Change Hydraulic Fluid in this section).



## WARNING

Before disconnecting or performing any work on the hydraulic system, all pressure in the system must be relieved. See Relieving Hydraulic System Pressure in the General Information section.

4. Disconnect all hydraulic hoses connected to the hydraulic fittings on the piston and gear pumps. Allow hoses to drain into a suitable container and plug hose openings to prevent contamination.



## CAUTION

Support piston and gear pumps when removing them from the pump support and pump mount plate to prevent them from falling and causing personal injury.

5. Remove fasteners and spacers securing the pump mount plate to the engine and pump support. Note location of cap screws, washers, nuts and spacers for assembly purposes. Pull pump mount plate with pumps, pump pulley, and idler assembly from the machine.

6. Remove both cap screws and flat washers securing gear pump to the piston pump. Separate gear pump and O-ring from the piston pump. Plug openings of gear pump to prevent contamination.

7. If hydraulic fittings are to be removed from piston pump, mark fitting orientation to allow correct assembly. Remove hydraulic fittings and O-rings from the piston pump as needed.

8. Remove pulley from the taper lock bushing:

A. Remove cap screws securing pulley to the taper lock bushing.

**IMPORTANT: Excessive or unequal pressure on the cap screws can break the bushing flange.**

B. Insert cap screws into threaded removal holes of the pulley. Tighten screws progressively and evenly until the pulley is loose on the bushing. Remove pulley from the bushing.

9. Loosen set screw that secures bushing to piston pump. Remove bushing from the pump shaft.

10. Remove both lock nuts, flat washers, and cap screws that secure the piston pump to the pump mount plate. Remove pump from plate.

11. If hydraulic fittings are to be removed from pump, mark fitting orientation to allow correct assembly.

### Piston Pump Installation (Fig. 104 & 105)

1. If hydraulic fittings were removed from piston pump, install fittings to pump using marks made during the removal process to properly orientate fittings.

2. Position and secure piston pump to the pump mount plate with both flat washers, cap screws, and lock nuts.

3. Place key into pump shaft slot. Slide taper lock bushing onto the piston pump shaft with bushing flange toward pump housing.

4. Make sure that tapered surfaces of pulley and taper lock bushing are thoroughly clean (no oil, grease, dirt, rust, etc.).

5. Position pulley to taper lock bushing and align non-threaded holes of pulley with threaded holes of bushing. Loosely install three (3) cap screws with lock washers to bushing and pulley.

6. Install O-rings and hydraulic fittings to their original positions on the piston pump.

**Note:** If installing a new gear pump to the piston pump, make sure to remove the plug from the suction port of the gear pump (Fig. 106). The gear pump suction fitting must be on the same side as the trunnion of the piston pump.

7. Remove plugs from the gear pump. Secure O-ring and gear pump to the piston pump with both flat washers and cap screws. Torque fasteners from 27 to 31 ft- lb (37 to 42 N- m).

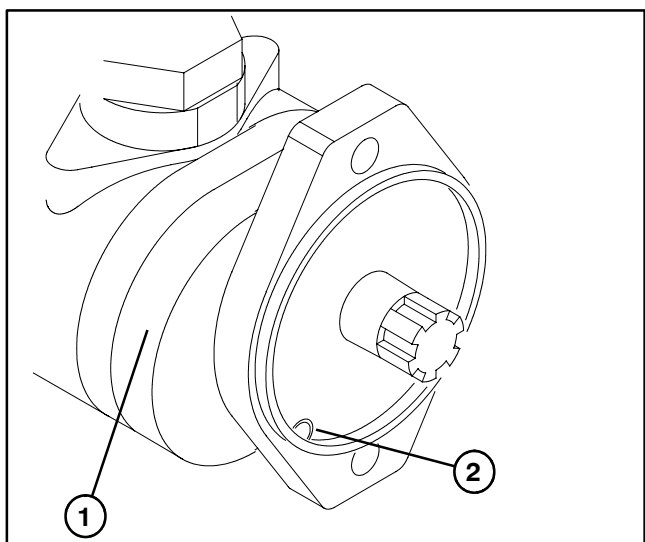

Figure 106

1. Gear pump

2. Suction port





## CAUTION

**Support piston and gear pumps when installing them to the machine to prevent them from falling and causing personal injury.**

8. Position pump mount plate with pumps, pump pulley, and idler assembly to the machine. Install fasteners and spacers securing the pump mount plate to the engine and pump support. Tighten fasteners securely.

9. Remove plugs from hydraulic hoses. Connect all hydraulic hoses as follows:

- A. Secure O-rings, fittings, and hydraulic hoses to the gear pump.
- B. Connect hydraulic suction hose from the hydraulic tank to the gear pump barb fitting with hose clamp.
- C. Secure O-rings, fittings, and hydraulic hoses to the piston pump.

10. Install neutral arm assembly to the piston pump as follows:

- A. Position neutral bracket to the mount plate and the pump lever to the pump trunnion.
- B. Secure pump lever to the piston pump trunnion with flat washer and cap screw.
- C. Secure neutral bracket to the pump mount plate with flange head screw and flange nut. Secure neutral bracket to the piston pump with both flange head screws.
- D. Connect traction control cable to the pump lever.



## CAUTION

**The extension spring is under tension and may cause personal injury during installation. Use caution when installing the spring to the pump lever.**

- E. Install extension spring to the cable support bracket and neutral arm.

11. Install traction belt to the pump pulley (see Replace Traction Belt).

12. Using a straight edge across the lower face of the pump pulley, verify traction belt alignment across engine and pump pulleys. Slide pulley and taper lock bushing on pump shaft so that traction belt and straight edge are aligned indicating correct position of pump pulley. Secure taper lock bushing in position with set screw.

**IMPORTANT: When tightening bushing cap screws, tighten in three equal steps and in a circular pattern.**

13. Secure taper lock bushing by tightening three (3) cap screws to a torque from 90 to 120 in-lb (10.2 to 13.6 N-m) in three equal steps and in a circular pattern to secure pulley and taper lock bushing.

14. Check that belt alignment is still correct. If needed, loosen and re-adjust pulley and taper lock bushing location on pump shaft to allow for correct belt alignment.

15. Fill hydraulic tank with **new** hydraulic fluid (see Traction Unit Operator's Manual).

16. Adjust traction drive for neutral (see Adjust Traction Drive for Neutral).

## Piston Pump Service

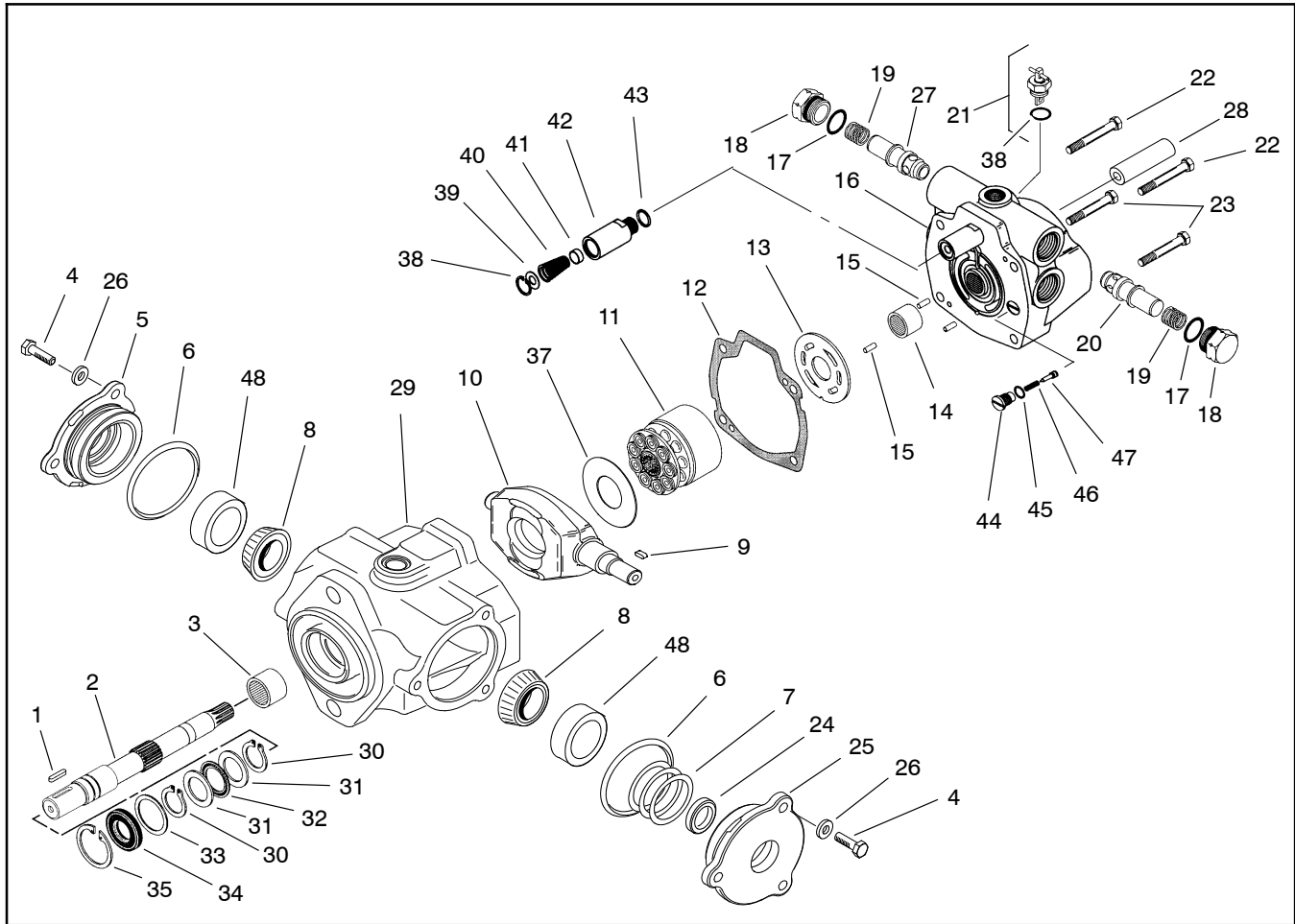

Figure 107

- |                                 |                               |                            |
|---------------------------------|-------------------------------|----------------------------|
| 1. Key                          | 17. O-ring                    | 33. Washer                 |
| 2. Drive shaft                  | 18. Plug                      | 34. Shaft seal             |
| 3. Bearing                      | 19. Spring                    | 35. Retaining ring         |
| 4. Cap screw (3 used per plate) | 20. Seat                      | 36. Retaining ring         |
| 5. Cover plate                  | 21. Bypass valve              | 37. Cam plate insert       |
| 6. O-ring                       | 22. Cap screw                 | 38. Retaining ring         |
| 7. Shim                         | 23. Cap screw                 | 39. Washer                 |
| 8. Bearing cone                 | 24. Shaft seal                | 40. Charge relief spring   |
| 9. Key                          | 25. Cover plate               | 41. Charge relief poppet   |
| 10. Cam plate                   | 26. Washer (3 used per plate) | 42. Charge relief housing  |
| 11. Rotating kit                | 27. Relief valve              | 43. O-ring                 |
| 12. Gasket                      | 28. Coupler                   | 44. Cartridge              |
| 13. Cam plate                   | 29. Housing                   | 45. O-ring                 |
| 14. Bearing                     | 30. Retaining ring            | 46. Bleed-off spring       |
| 15. Dowel pin                   | 31. Thrust washer             | 47. Bleed-off valve poppet |
| 16. Back plate                  | 32. Thrust bearing            | 48. Bearing cup            |

**NOTE:** For repair of the piston pump, see the Eaton Medium Duty Piston Pump Repair Information Model 70160 Variable Displacement Piston Pump at the end of this chapter.

**IMPORTANT:** If a piston pump failure occurred, refer to Traction Circuit (Closed Loop) Component Failure in the General Information section for information regarding the importance of removing contamination from the traction circuit.

This page is intentionally blank.

## Gear Pump

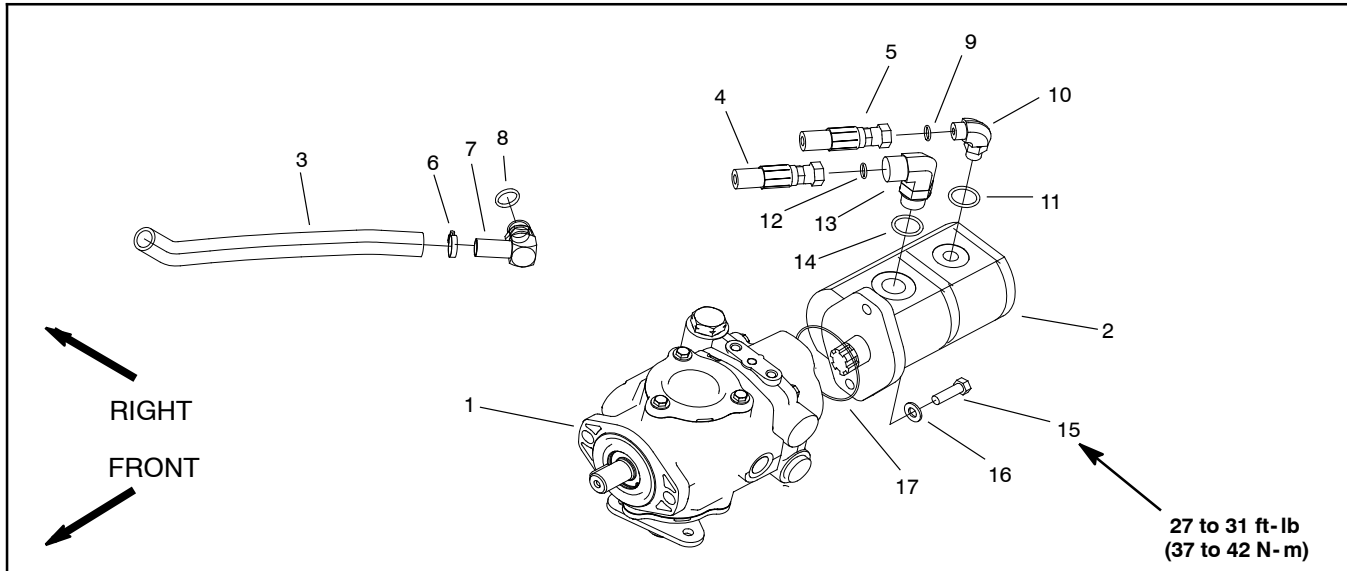

Figure

- |  |                             |                           |
|--|-----------------------------|---------------------------|
| 1. Piston pump                         | 7. Hydraulic barbed fitting | 13. 90° hydraulic fitting |
| 2. Gear pump                           | 8. O-ring                   | 14. O-ring                |
| 3. Hydraulic hose (tank suction)       | 9. O-ring                   | 15. Cap screw             |
| 4. Hydraulic hose (hydraulic manifold) | 10. 90° hydraulic fitting   | 16. Flat washer           |
| 5. Hydraulic hose (steering valve)     | 11. O-ring                  | 17. O-ring                |
| 6. Hose clamp                          | 12. O-ring                  |                           |

### Removal (Fig. 108)

1. Remove muffler from the engine to gain access to the gear pump (see Muffler Removal in Chapter 3 - Kubota Diesel Engine).
2. Drain hydraulic oil from hydraulic tank (see Change Hydraulic Fluid in this section).



## WARNING

**Before disconnecting or performing any work on the hydraulic system, all pressure in the system must be relieved. See Relieving Hydraulic System Pressure in the General Information section.**

3. Remove gear pump from the piston pump using Figure 108 as guide.
4. If hydraulic fittings are to be removed from pump, mark fitting orientation to allow correct assembly.

### Installation (Fig. 108)

1. If hydraulic fittings were removed from gear pump, install fittings to pump using marks made during the removal process to properly orientate fittings.

**IMPORTANT: Position gear pump to the piston pump so that the gear pump suction port is facing down.**

2. Install gear pump to the piston pump using Figure 108 as guide. Torque pump mounting cap screws from 27 to 31 ft-lb (37 to 42 N-m).
3. Fill hydraulic tank with **new** hydraulic fluid (see Tractor Unit Operator's Manual).
4. Install muffler to the engine (see Muffler Installation in Chapter 3 - Kubota Diesel Engine).

This page is intentionally blank.

## Gear Pump Service (Serial Numbers Below 260000400)

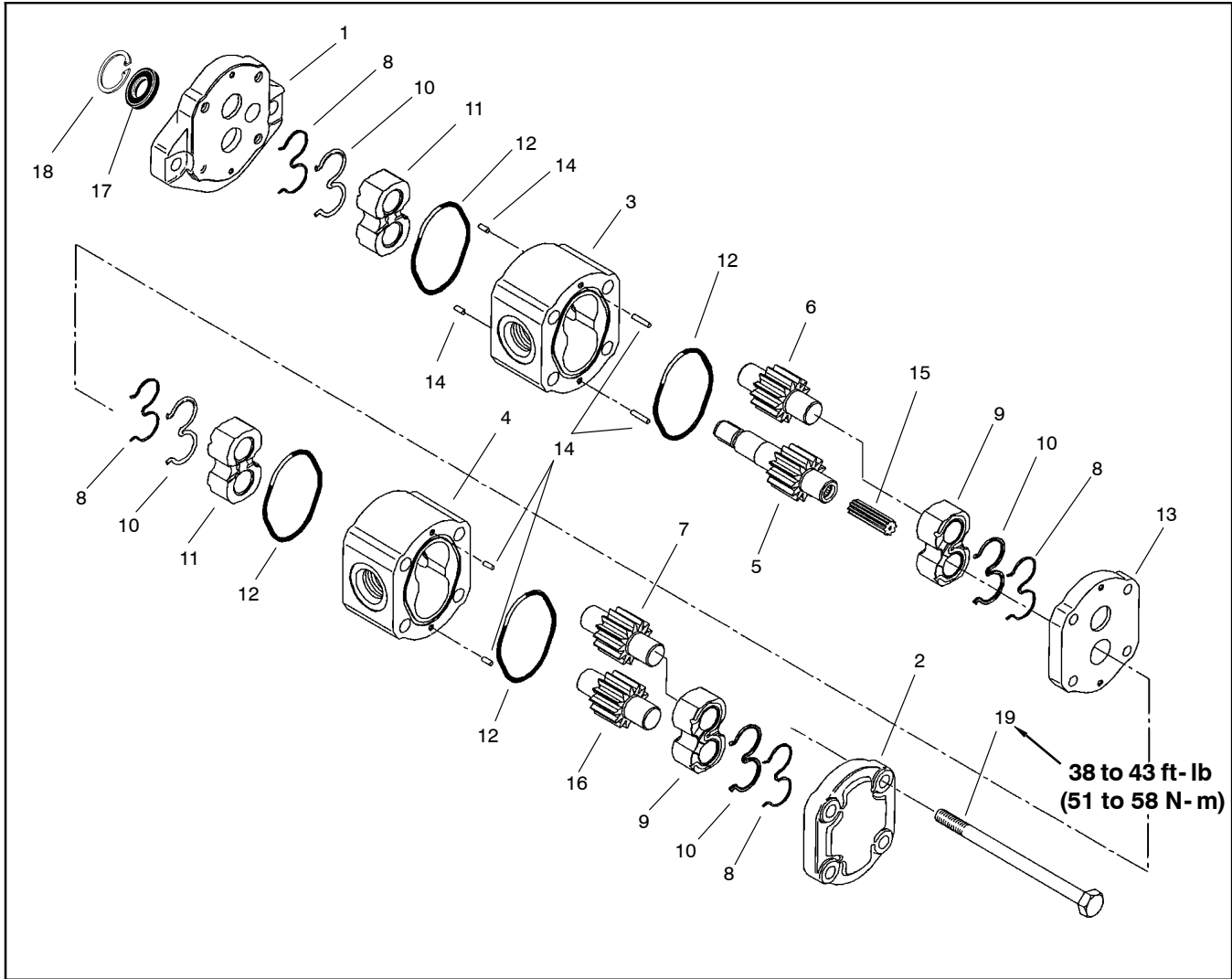

Figure

- |                     |                      |                                  |
|---------------------|----------------------|----------------------------------|
| 1. Front plate      | 8. Back-up gasket    | 14. Dowel                        |
| 2. Back plate       | 9. Rear wear plate   | 15. Coupler                      |
| 3. Front body       | 10. Pressure seal    | 16. Drive gear                   |
| 4. Rear body        | 11. Front wear plate | 17. Shaft seal (if equipped)     |
| 5. Drive gear       | 12. O-ring           | 18. Retaining ring (if equipped) |
| 6. Front idler gear | 13. Adapter Plate    | 19. Cap screw                    |
| 7. Rear idler gear  |                      |                                  |

### Disassembly (Fig. 109)

1. Plug pump ports and clean the outside of the pump thoroughly. After cleaning, remove plugs and drain any oil out of the pump.

2. Use a marker to make a **diagonal** line across the front plate, front body, adapter plate, rear body, and back plate for assembly purposes (Fig. 110).

**IMPORTANT: Avoid using excessive clamping pressure on the pump housing to prevent distorting the housing.**

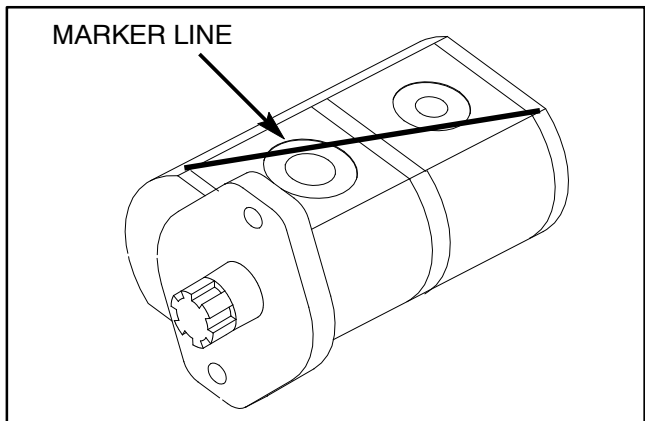

Figure 110

3. Clamp mounting flange of pump in a vise with the shaft end down.

4. Loosen cap screws from the back plate.

5. Remove pump from the vise. Turn pump so that the shaft end is facing down. Remove cap screws.

6. Remove back plate from the rear body.

7. Carefully remove rear body. Lift body straight up to remove. Make sure the rear wear plate remains on the drive and idler gear shafts. Remove and discard O-rings from the rear body.

**IMPORTANT: Note position of the open and closed side of the wear plates before removing from the adapter plate. Also, identify wear plates (front and rear) for proper reassembly.**

8. Carefully remove rear wear plate, idler gear, drive gear, and front wear plate from the adapter plate.

9. Remove coupler from the drive gear shaft.

10. Remove adapter plate.

11. Carefully remove front body. Lift body straight up to remove. Make sure the rear wear plate remains on the drive and idler gear shafts. Remove and discard O-rings from the front body.

**IMPORTANT: Note position of the open and closed side of the wear plates before removing from the front plate. Also, identify wear plates (front and rear) for proper reassembly.**

12. Carefully remove rear wear plate, idler gear, drive gear, and front wear plate from front plate.

13. Remove back-up gasket and pressure seal from all wear plates.

**NOTE:** Gear pumps on early production machines may have had a shaft seal and retaining ring in the front plate. Pumps used on later production machines did not have a seal or retaining ring. The seal and retaining ring are not needed on any Groundsmaster 3500- D.

14. If retaining ring and seal exist in front plate, remove them from the front plate. Make sure to not damage the front plate counter bore when removing components.

15. Discard all removed seals and gaskets.

### Inspection (Fig. 109)

1. Remove all nicks and burrs from all pump parts with emery cloth.



2. Clean all parts with solvent. Dry all parts with compressed air.

3. Inspect drive gears and idler gears for the following (Fig. 111):

A. Drive gear shaft spline should be free of twisted or broken teeth.

B. Gear shafts should be free of rough surfaces and excessive wear at bushing points and sealing areas. Scoring, rough surfaces, or wear on gear shafts indicates need for replacement.

C. Gear teeth should be free of excessive scoring and wear. Any broken or nicked gear teeth must be replaced.

D. Inspect gear face edge for sharpness. Sharp edges of gears will mill into wear plates and, thus, must be replaced.

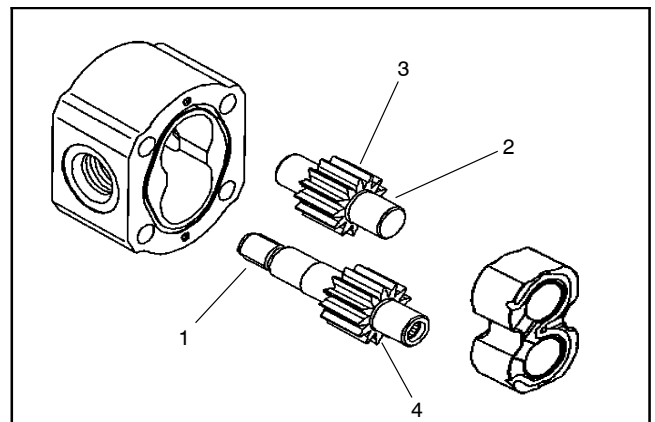

Figure 111

1. Gear shaft spline  
2. Gear shaft

3. Gear teeth  
4. Gear face edge

4. Inspect gear bodies for excessive scoring, gouges or wear. Evidence of damage indicates need for component replacement.

5. Inspect wear plates for the following:
  - A. Bearing areas should not have excessive wear or scoring.
  - B. Face of wear plates that are in contact with gears should be free of wear, roughness or scoring.
  - C. Thickness of wear plates should be equal.
6. Inspect front plate, back plate, and adapter plate for damage or wear.

#### Assembly (Fig. 109)

**Note:** When assembling the pump, check the marker line on each part to make sure the parts are properly aligned during reassembly.

1. Lubricate O-rings, pressure seals, back-up gaskets, and wear plates with a thin coat of petroleum jelly. Lubricate all other internal parts freely with clean hydraulic oil.

**NOTE:** A seal and retaining ring are not necessary in the front plate. The gear pump seal kit does not include these parts.

2. Place front plate on a flat surface with the internal machined surface facing up.

3. Apply a light coating of petroleum jelly to the pressure seals, back-up gaskets, and wear plate grooves.

4. Install the pressure seals, flat side outward, into the grooves in the wear plates. Follow by carefully placing the backup gaskets, flat side outward, between the pressure seals and the groove in the wear plate.

5. Apply a light coating of petroleum jelly to the exposed side of the front plate.

6. Lubricate the drive gear shaft with clean hydraulic oil. Insert the drive end of the drive shaft through the wear plate with the pressure seal side down and the open side of the pressure seal pointing to the suction side of the pump. Carefully install shaft into front plate.

7. Lubricate the front idler gear shaft with clean hydraulic oil. Install idler gear shaft into the remaining position in the wear plate. Apply a light coating of clean hydraulic oil to gear faces.

8. Install rear wear plate with pressure seal side up and open side of the pressure seal pointing to the suction side of the pump.

9. Apply a light coating of petroleum jelly to new O-rings and O-ring grooves in the front body. Install new O-rings to the front body.

10. Install locating dowels in front body. Align marker line on the body and front plate.

**IMPORTANT: Do not dislodge pressure seals, back-up gaskets or O-rings during pump assembly.**

11. Gently slide the front body onto the assembly. Firm hand pressure should be sufficient to engage the dowels.

12. Check to make sure that the surface of the wear plate is slightly below the face of the front body. If the wear plate is not below the front body, check assembly for a shifted pressure seal or O-ring. Correct before proceeding.

13. Apply a light coating of petroleum jelly to the exposed side of the adapter plate.

14. Place adapter plate on assembly using marker line for proper location. Firm hand pressure should be sufficient to engage the dowels.

15. Install coupler into drive gear.

16. Follow above procedure to install back section of the pump using the same precautions, lubrication, and alignment.

17. Install the four screws and hand tighten.

18. Place mounting flange of the pump into a vise with soft jaws. Alternately torque the screws from 38 to 43 ft-lb (51 to 58 N-m).

19. Remove pump from vise.

20. Place a small amount of clean hydraulic oil in the inlet of the pump and rotate the drive shaft away from the inlet one revolution. If any binding is noted, disassemble the pump and check for assembly problems.



This page is intentionally blank.

## Gear Pump Service (Serial Numbers Above 26000400)

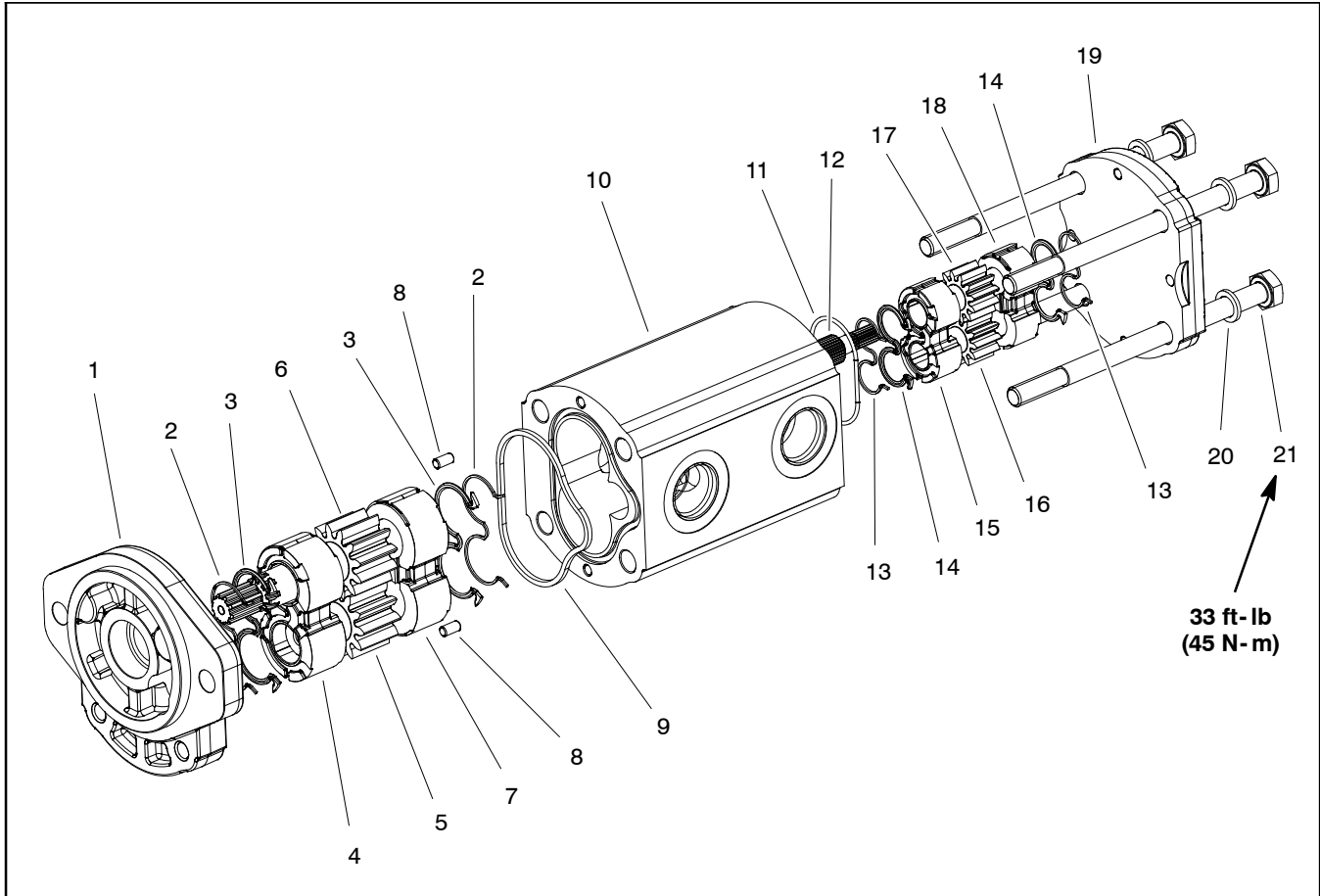

Figure

- |                       |                              |                        |
|-----------------------|------------------------------|------------------------|
| 1. Front cover        | 8. Dowel pin                 | 15. Front thrust plate |
| 2. Pressure seal      | 9. Seal                      | 16. Idler gear         |
| 3. Back-up gasket     | 10. Body                     | 17. Drive gear         |
| 4. Front thrust plate | 11. Seal                     | 18. Rear thrust plate  |
| 5. Idler gear         | 12. Splined connecting shaft | 19. Rear cover         |
| 6. Drive shaft        | 13. Pressure seal            | 20. Washer (4 used)    |
| 7. Rear thrust plate  | 14. Back-up gasket           | 21. Cap screw (4 used) |

### Disassembly (Fig. 112)

**NOTE:** The gear pump must be replaced as a complete assembly. Individual gears, housings and thrust plates are not available separately. Disassemble gear pump for cleaning, inspection and seal replacement only.

1. Plug pump ports and thoroughly clean exterior of pump with cleaning solvent. Make sure work area is clean.

2. Use a marker to make a **diagonal** line across the gear pump for assembly purposes (Fig. 113).

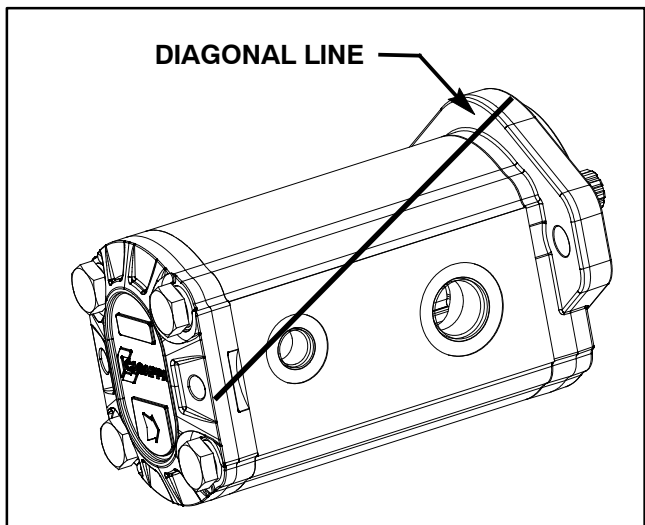

Figure 113

**IMPORTANT: Use caution when clamping gear pump in a vise to avoid distorting any pump components.**

3. Secure the front cover of the pump in a vise with the drive shaft pointing down.
4. Loosen the four (4) cap screws that secure pump assembly.
5. Remove pump from vise and remove fasteners.
6. Support the pump assembly and gently tap the pump case with a soft face hammer to loosen the pump sections. Be careful to not drop parts or disengage gear mesh.

**IMPORTANT: Mark the relative positions of the gear teeth and the thrust plates so they can be reassembled in the same position. Do not touch the gear surfaces as residue on hands may be corrosive to gear finish.**

7. Remove the thrust plates and seals from each pump section. Before removing each gear set, apply marking dye to mating teeth to retain "timing". Pump efficiency may be affected if the teeth are not installed in the same position during assembly. Keep the parts for each pump section together; do not mix parts between sections.

8. Clean all pump parts. Check all components for burrs, scoring, nicks and other damage.

9. Replace the entire pump assembly if parts are excessively worn or scored.

#### **Assembly (Fig. 112)**

1. Apply clean hydraulic oil to all parts before assembling.

**NOTE:** Pressure seals and back-up gaskets fit in grooves machined into thrust plates. Body seals fit in grooves machined in body faces.

2. Assemble pump sections starting at front cover end. Apply grease or petroleum jelly to new section seals to hold them in position during gear pump assembly.
3. After pump has been assembled, tighten cap screws by hand. Rotate the drive shaft to check for binding. Protect the shaft if using a pliers to rotate shaft.
4. Tighten the four (4) cap screws evenly in a crossing pattern to a torque of 33 ft- lb (45 N- m).

# Steering Control Valve

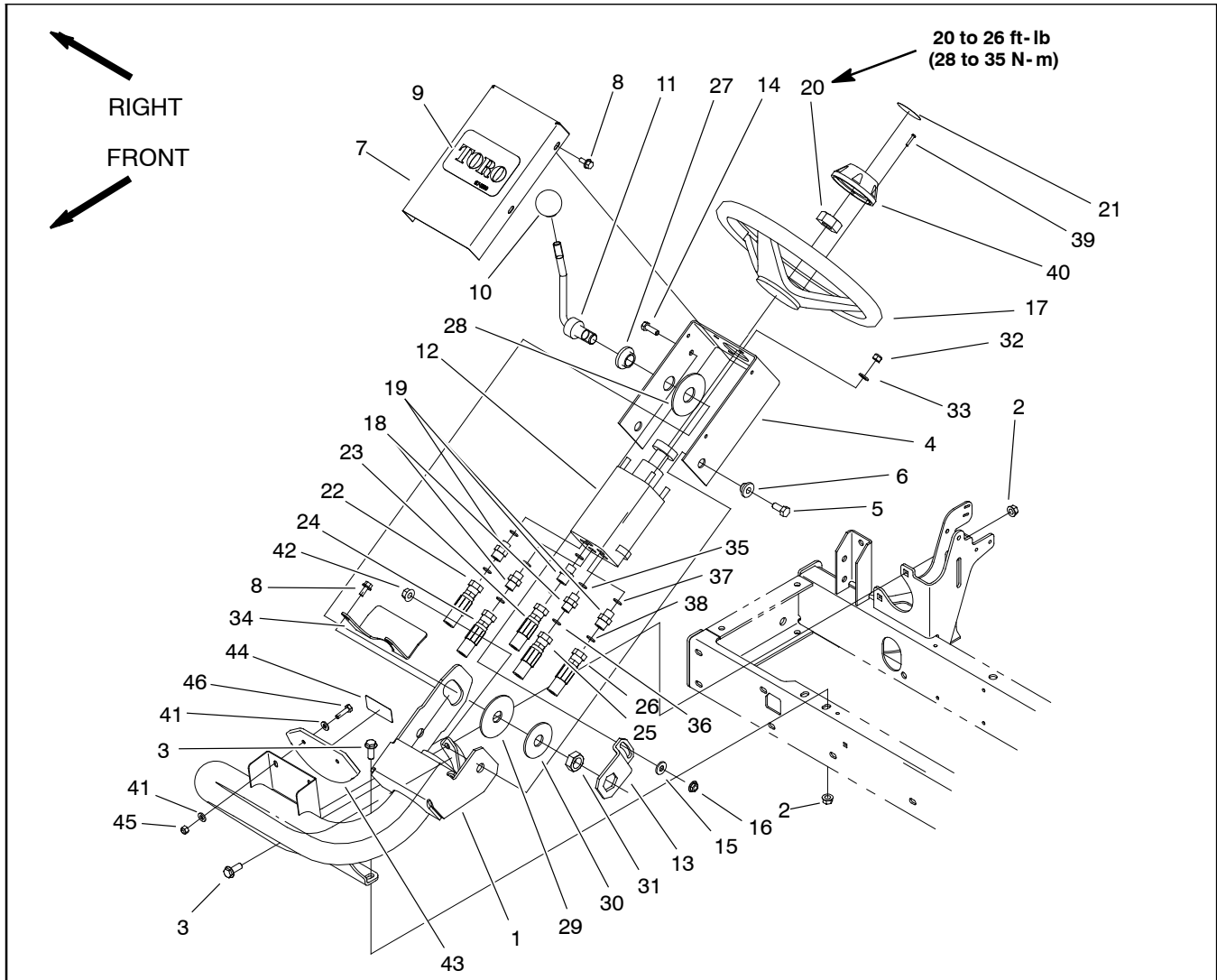

Figure

- |                            |                        |                        |
|----------------------------|------------------------|------------------------|
| 1. Steering arm            | 17. Steering wheel     | 32. Lock nut           |
| 2. Flange nut              | 18. Hydraulic fitting  | 33. Flat washer        |
| 3. Flange head screw       | 19. Hydraulic fitting  | 34. Steering shield    |
| 4. Steering valve bracket  | 20. Steering wheel nut | 35. O-ring             |
| 5. Cap screw               | 21. Toro decal         | 36. O-ring             |
| 6. Pivot hub               | 22. Hydraulic hose     | 37. O-ring             |
| 7. Steering cover          | 23. Hydraulic hose     | 38. O-ring             |
| 8. Cap screw               | 24. Hydraulic hose     | 39. Philips head screw |
| 9. Toro decal              | 25. Hydraulic hose     | 40. Steering wheel cap |
| 10. Ball knob              | 26. Hydraulic hose     | 41. Flat washer        |
| 11. Steering tilt lever    | 27. Tilt steering boss | 42. Flange nut         |
| 12. Steering control valve | 28. Friction disc      | 43. Slope indicator    |
| 13. Tilt bracket           | 29. Friction disc      | 44. Decal              |
| 14. Cap screw              | 30. Flat washer        | 45. Lock nut           |
| 15. Flat washer            | 31. Jam nut            | 46. Cap screw          |

## Removal



# WARNING

Before disconnecting or performing any work on the hydraulic system, all pressure in the system must be relieved. See Relieving Hydraulic System Pressure in the General Information section.

1. Remove steering control valve from the steering column using Figures 114, 115, and 116 as guides.

## Installation

1. Install steering control valve to the steering column using Figures 114, 115, and 116 as guides. When installing steering control valve, note position of end cover protrusion as shown (Fig. 116).

2. Make sure hydraulic tank is full. Add correct oil if necessary (see Check Hydraulic System Fluid).

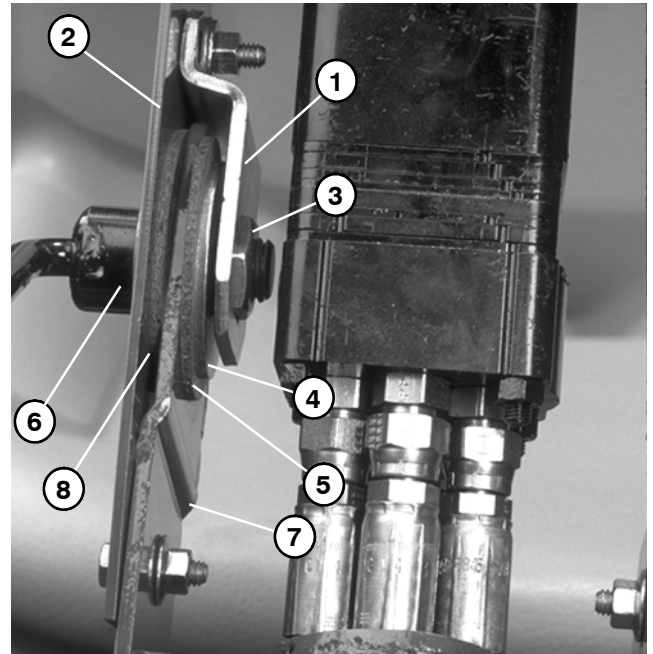

Figure 115

- |                           |                        |
|---------------------------|------------------------|
| 1. Tilt bracket           | 5. Friction disc       |
| 2. Steering valve bracket | 6. Steering tilt lever |
| 3. Jam nut                | 7. Steering arm        |
| 4. Flat washer            | 8. Friction disc       |

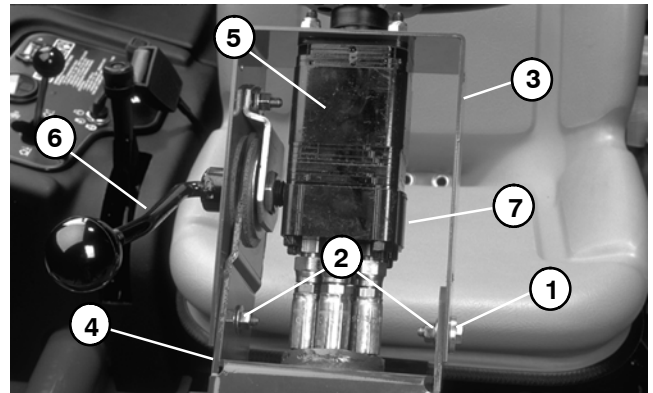
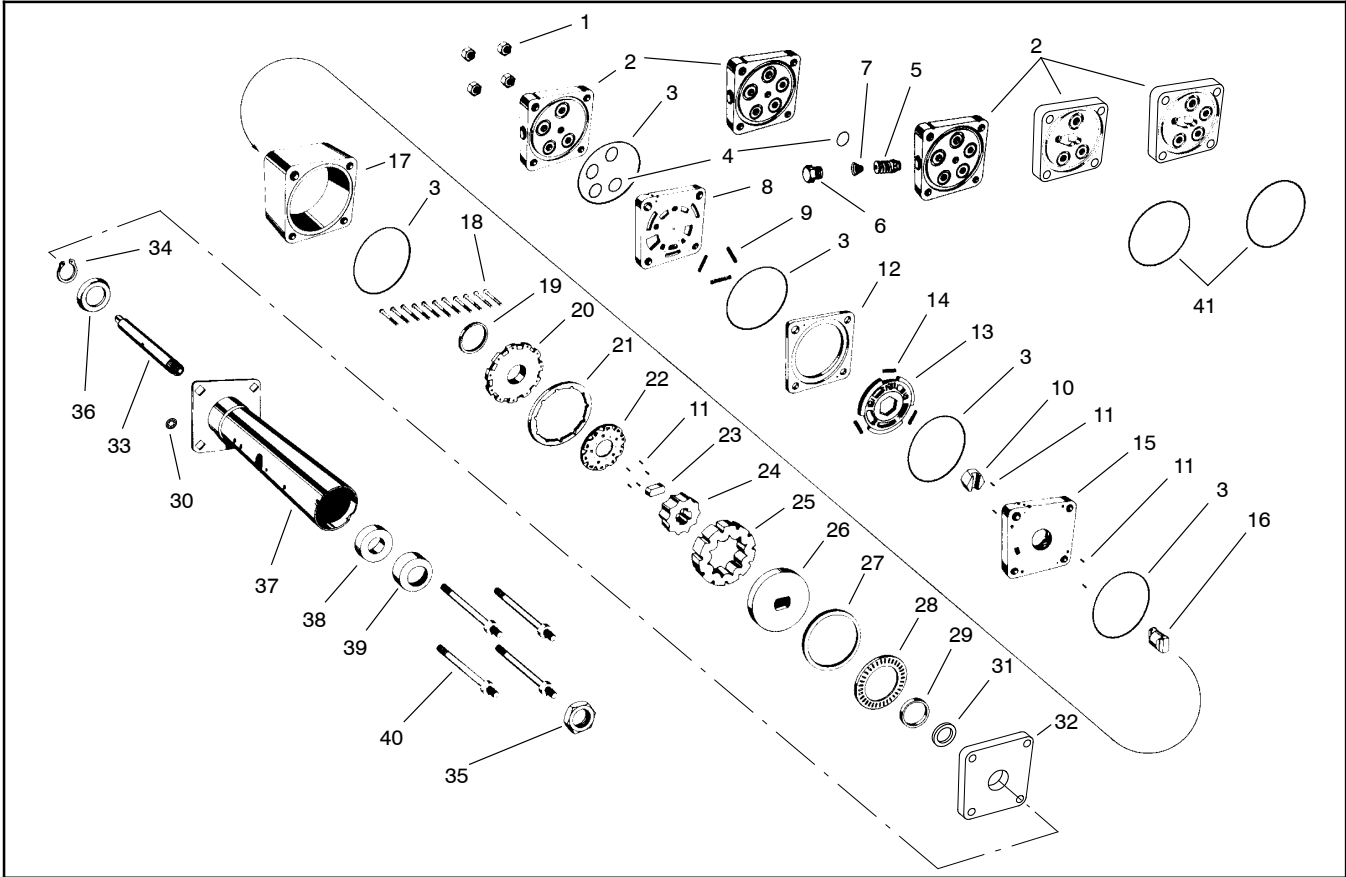

Figure 116

- |                           |                           |
|---------------------------|---------------------------|
| 1. Cap screw              | 5. Steering control valve |
| 2. Flange nuts            | 6. Steering tilt lever    |
| 3. Steering valve bracket | 7. End cover protrusion   |
| 4. Steering arm           |                           |

## Steering Control Valve Service (Serial Numbers Below 24000000)



Figure

- |                           |                           |                                   |
|---------------------------|---------------------------|-----------------------------------|
| 1. Nut                    | 15. Isolation manifold    | 29. Face seal                     |
| 2. Port cover             | 16. Drive link            | 30. Push nut                      |
| 3. Seal ring              | 17. Metering ring         | 31. Seal spacer                   |
| 4. O-ring                 | 18. Socket head screw     | 32. Upper cover plate             |
| 5. Relief valve cartridge | 19. Commutator seal       | 33. Input shaft                   |
| 6. Plug                   | 20. Commutator cover      | 34. Retaining ring                |
| 7. Coil spring            | 21. Commutator ring       | 35. Nut                           |
| 8. Port manifold          | 22. Commutator            | 36. Retaining plate               |
| 9. Spring                 | 23. Drive link spacer     | 37. Upper cover & jacket assembly |
| 10. Drive assembly        | 24. Rotor                 | 38. Bushing                       |
| 11. Alignment pin         | 25. Stator                | 39. Seal                          |
| 12. Valve ring            | 26. Drive plate           | 40. Special bolt                  |
| 13. Valve plate           | 27. Thrust bearing spacer | 41. Seal ring (white)             |
| 14. Spring                | 28. Thrust bearing        |                                   |

**Note:** For repair of the steering control valve, see the Ross Hydraguide™ Hydrostatic Steering System HGF Series Service Procedure at the end of this chapter.

# Steering Control Valve Service (Serial Numbers Above 24000000)

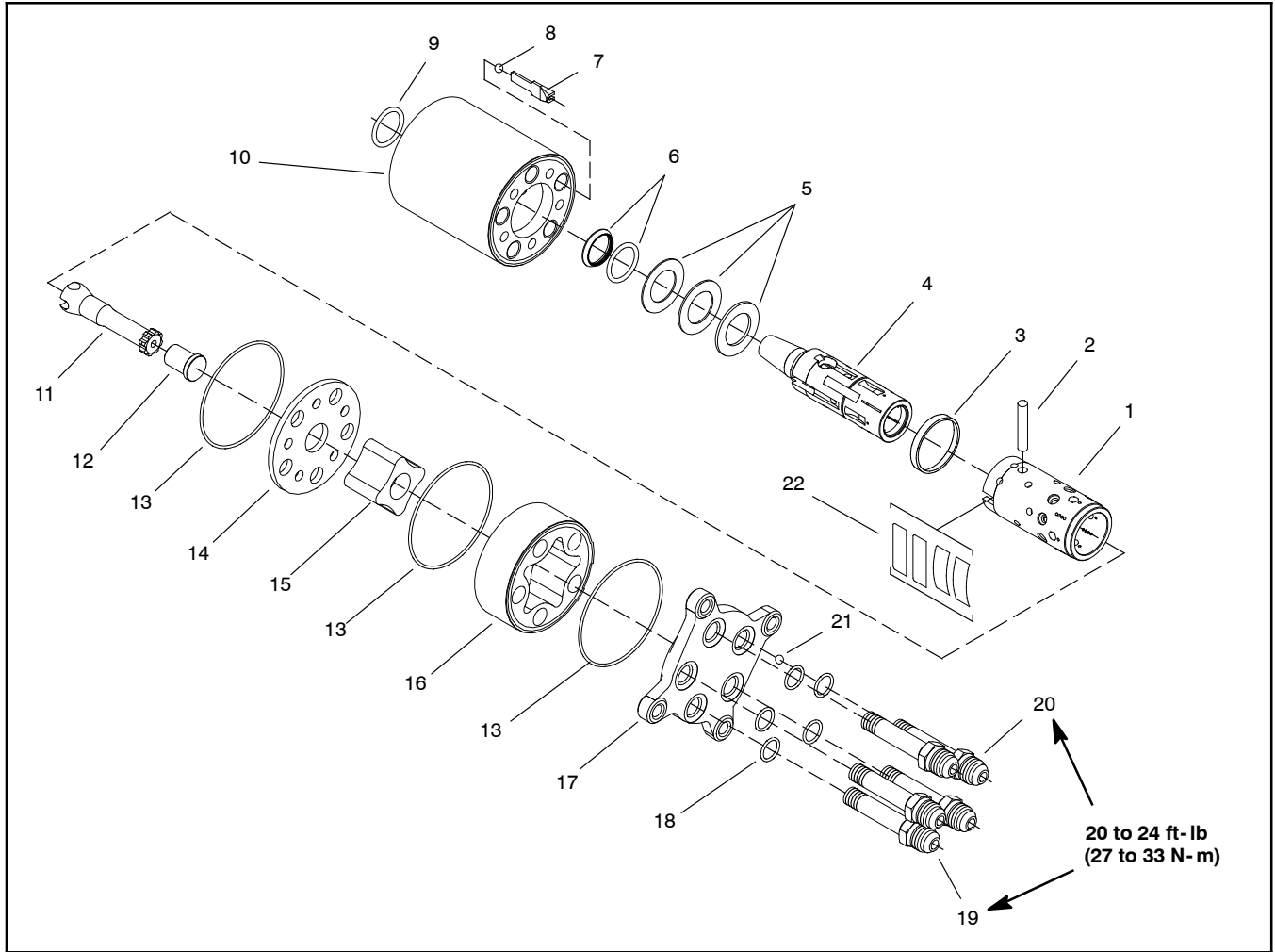

Hydraulic System

Figure

- |   |   |  |
|---|---|--|
| <ul style="list-style-type: none"> <li>1. Sleeve</li> <li>2. Cross pin</li> <li>3. Ring</li> <li>4. Spool</li> <li>5. Bearing assembly</li> <li>6. Shaft seal</li> <li>7. Ball stop</li> <li>8. Ball</li> </ul> | <ul style="list-style-type: none"> <li>9. Dust seal ring 118</li> <li>10. Housing</li> <li>11. Cardan shaft</li> <li>12. Spacer</li> <li>13. O-ring</li> <li>14. Distribution plate</li> <li>15. Inner gearwheel</li> </ul> | <ul style="list-style-type: none"> <li>16. Outer gearwheel</li> <li>17. End cover</li> <li>18. O-ring (5 used)</li> <li>19. Screw/fitting (ports L, R, T)</li> <li>20. Screw/fitting (ports P and E)</li> <li>21. P port check ball</li> <li>22. Spring set</li> </ul> |
|---|---|--|

**NOTE:** For service of the steering control valve, see the Sauer/Danfoss Steering Unit Type OSPM Service Manual at the end of this chapter.

# Sidewinder

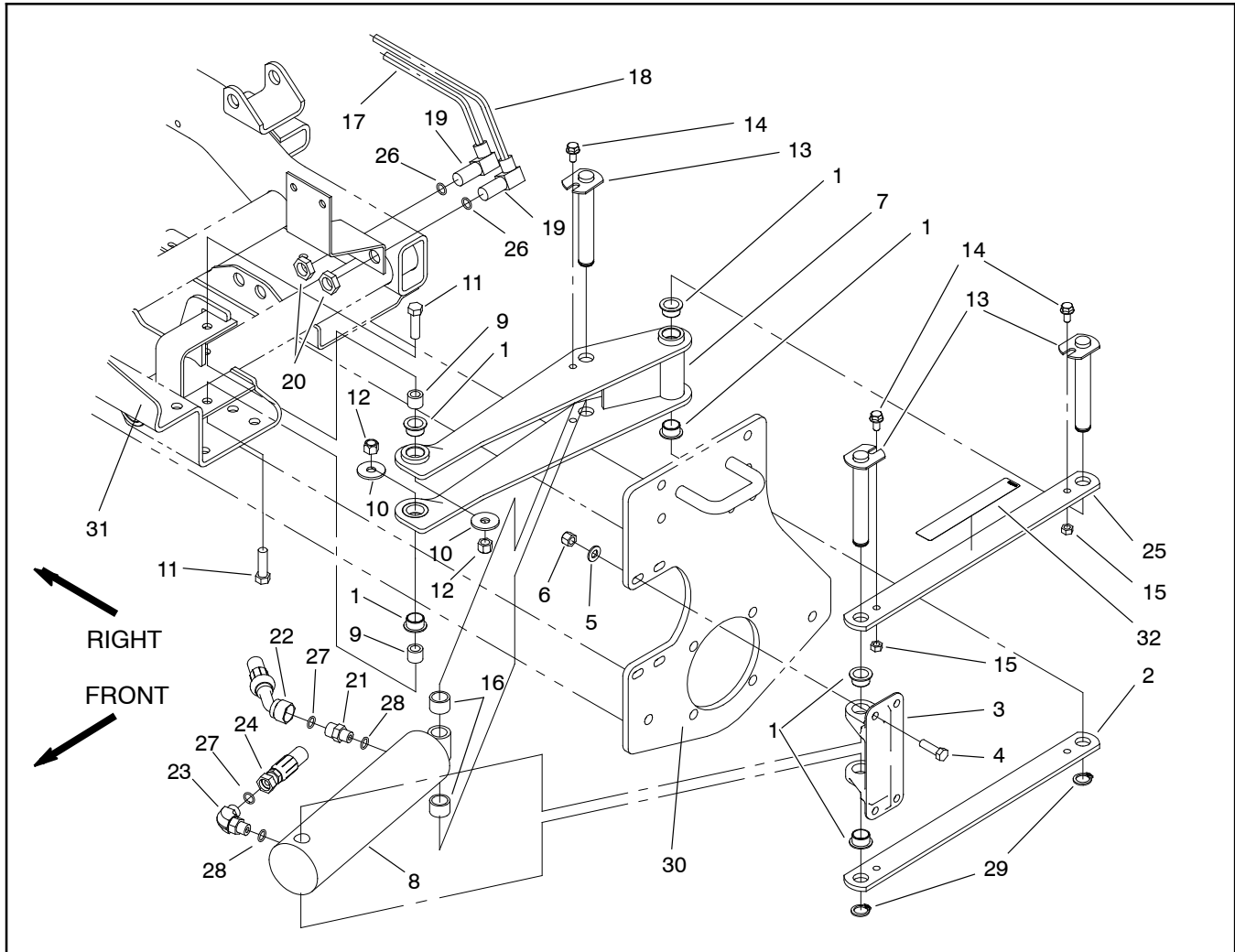

Figure

- |                       |                                |                           |
|-----------------------|--------------------------------|---------------------------|
| 1. Bushing            | 12. Lock nut 119               | 23. 90° hydraulic fitting |
| 2. Scissor link       | 13. Welded pin                 | 24. Hydraulic hose        |
| 3. Scissor mount      | 14. Flange head screw          | 25. Scissor link          |
| 4. Cap screw          | 15. Lock nut                   | 26. O-ring                |
| 5. Flat washer        | 16. Spacer                     | 27. O-ring                |
| 6. Lock nut           | 17. Hydraulic tube             | 28. O-ring                |
| 7. Scissor frame      | 18. Hydraulic tube             | 29. Retaining ring        |
| 8. Hydraulic cylinder | 19. 90° hydraulic fitting      | 30. Lower frame           |
| 9. Spacer             | 20. Bulkhead lock nut          | 31. Frame                 |
| 10. Flat washer       | 21. Straight hydraulic fitting | 32. Pinch point decal     |
| 11. Cap screw         | 22. Hydraulic hose             |                           |



## Removal



## WARNING

Before disconnecting or performing any work on the hydraulic system, all pressure in the system must be relieved. See Relieving Hydraulic System Pressure in the General Information section.

1. Remove hydraulic cylinder from the frame using Figure 119 as guide.
2. If hydraulic fittings are to be removed from cylinder, mark fitting orientation to allow correct assembly.

## Installation

1. If hydraulic fittings were removed from cylinder, install fittings to cylinder using marks made during the removal process to properly orientate fittings.
2. Install hydraulic cylinder to the frame using Figure 119 as guide.
3. Make sure hydraulic tank is full. Add correct oil if necessary (see Check Hydraulic System Fluid).
4. Adjust scissors mount as follows:
  - A. Shift sidewinder fully to the left (fully retract cylinder).
  - B. Loosen four cap screws and locknuts securing the scissor mount to lower frame.
  - C. The gap between the scissor frame and lower frame and the gap between the scissor frame and the sidewinder carrier must be equal distances within 0.060 inch (1.5 mm).
  - D. Tighten four cap screws and lock nuts to secure the scissor mount.

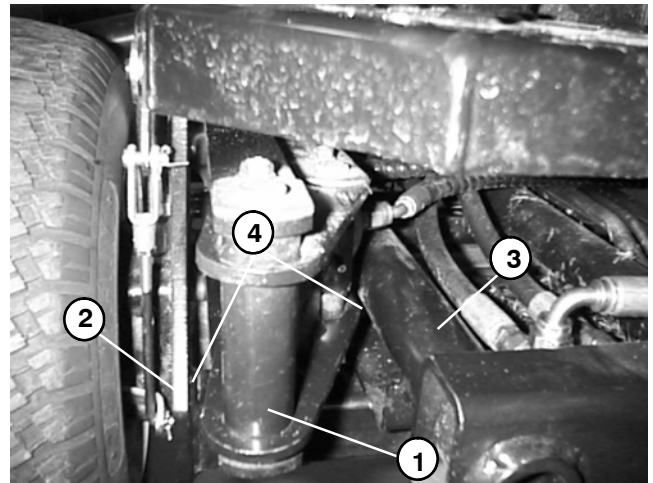
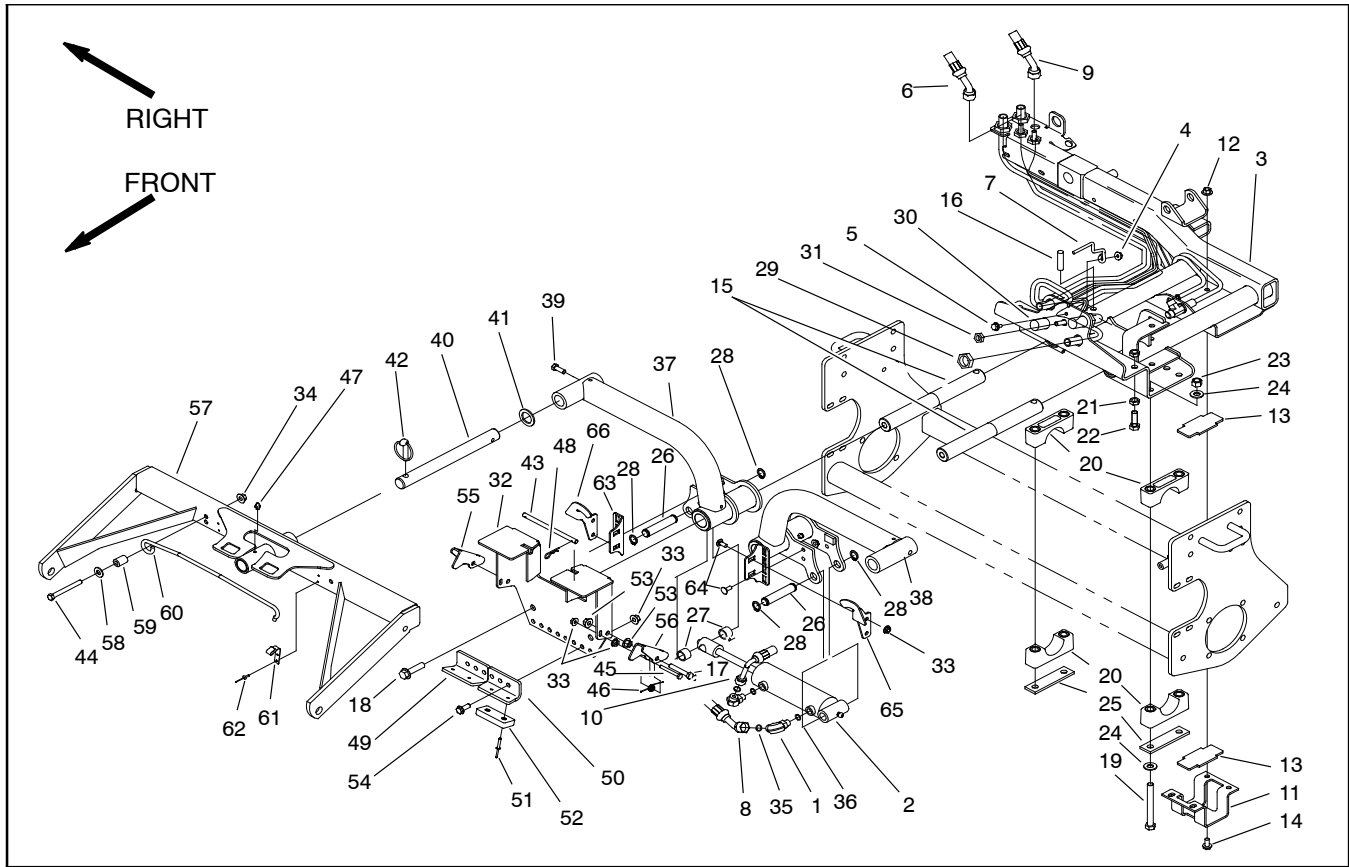

Figure 120

- |                  |                       |
|------------------|-----------------------|
| 1. Scissor frame | 3. Sidewinder carrier |
| 2. Lower frame   | 4. Gaps               |

# Front Lift Cylinder



Figure

- |                                |                             |                         |
|--------------------------------|-----------------------------|-------------------------|
| 1. 90° hydraulic fitting       | 23. Lock nut 121            | 45. Cap screw           |
| 2. Hydraulic cylinder          | 24. Thrust washer           | 46. Torsion spring      |
| 3. Sidewinder carrier assembly | 25. Slide support bar       | 47. Grease fitting      |
| 4. Flange nut                  | 26. Pin                     | 48. Hair pin            |
| 5. Flange head screw           | 27. Spacer                  | 49. RH deck stop        |
| 6. Hydraulic hose              | 28. External retaining ring | 50. LH deck stop        |
| 7. Centering wire              | 29. Bulkhead nut            | 51. Rivet               |
| 8. Hydraulic hose              | 30. Hydraulic tube          | 52. Rubber bumper       |
| 9. Hydraulic hose              | 31. Bulkhead nut            | 53. Flange nut          |
| 10. Hydraulic hose             | 32. Carrier stop bracket    | 54. Flange head screw   |
| 11. Slide bracket              | 33. Nut                     | 55. RH pivot bracket    |
| 12. Flange nut                 | 34. Flange nut              | 56. LH pivot bracket    |
| 13. Plastic slide              | 35. O-ring                  | 57. Front carrier frame |
| 14. Flange head screw          | 36. O-ring                  | 58. Flat washer         |
| 15. Lift arm pivot shaft       | 37. RH liftarm              | 59. Latch tube          |
| 16. Roll pin                   | 38. LH liftarm              | 60. Latch rod           |
| 17. Cap screw                  | 39. Cap screw               | 61. Rod clip            |
| 18. Flange head screw          | 40. Shaft                   | 62. Rivet               |
| 19. Cap screw                  | 41. Thrust washer           | 63. Actuator bracket    |
| 20. Bearing cap                | 42. Lynch pin               | 64. Carriage screw      |
| 21. Jam nut                    | 43. Rod                     | 65. RH actuator         |
| 22. Cap screw                  | 44. Cap screw               | 66. LH actuator         |

## Removal



### WARNING

Before disconnecting or performing any work on the hydraulic system, all pressure in the system must be relieved. See Relieving Hydraulic System Pressure in the General Information section.

1. Remove front lift cylinder from the frame and lift arm using Figure 121 as guide.
2. If hydraulic fittings are to be removed from lift cylinder, mark fitting orientation to allow correct assembly.

## Installation

1. If hydraulic fittings were removed from lift cylinder, install fittings to cylinder using marks made during the removal process to properly orientate fittings.

**IMPORTANT: With lift arms raised fully, hydraulic hoses should be routed as shown in Figure 122. Make sure clearance between hydraulic hose and lift arm is from 0.040 to 0.120 inches (1.0 to 3.0 mm). Do not loosen hoses for repositioning without relieving system hydraulic pressure first.**

2. Install front lift cylinder to the frame and lift arm using Figure 121 as guide.
3. Make sure hydraulic tank is full. Add correct oil if necessary (see Check Hydraulic System Fluid).
4. Adjust front lift arm (see Adjust Front Lift Arm in Chapter 7 - Cutting Units).

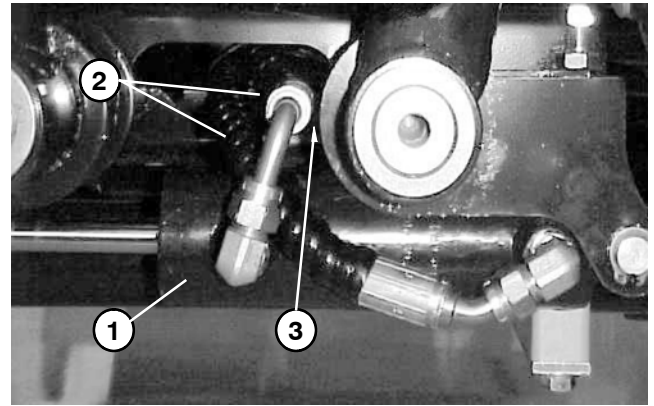
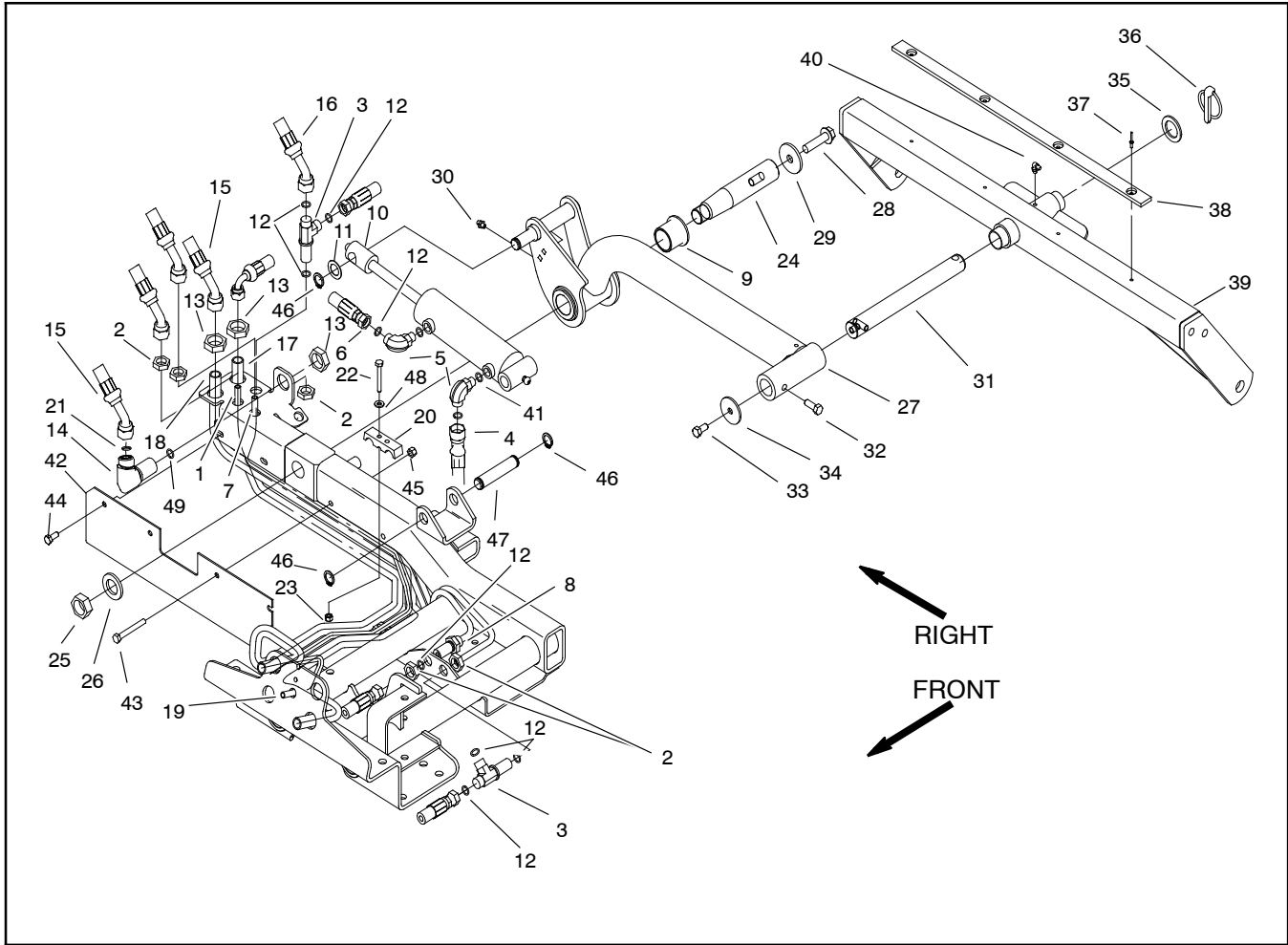

Figure 122

1. Lift cylinder
2. Hydraulic hoses
3. Clearance

# Rear Lift Cylinder



Figure

- |                               |                              |                             |
|-------------------------------|------------------------------|-----------------------------|
| 1. Hydraulic tube             | 18. Hydraulic tube           | 34. Rebound washer          |
| 2. Bulkhead locknut           | 19. Hydraulic tube           | 35. Thrust washer           |
| 3. Hydraulic T-fitting        | 20. Tube clamp               | 36. Lynch pin               |
| 4. Hydraulic hose             | 21. O-ring                   | 37. Pop rivet               |
| 5. 90° hydraulic fitting      | 22. Cap screw                | 38. Wear strip              |
| 6. Hydraulic hose             | 23. Lock nut                 | 39. Rear cutting unit frame |
| 7. Hydraulic tube             | 24. Rear pivot shaft         | 40. Grease fitting          |
| 8. Straight hydraulic fitting | 25. Jam nut                  | 41. O-ring                  |
| 9. Castor bushing             | 26. Washer                   | 42. Guard                   |
| 10. Hydraulic cylinder        | 27. Lift arm assembly        | 43. Cap screw               |
| 11. Thrust washer             | 28. Flange head screw        | 44. Cap screw               |
| 12. O-ring                    | 29. Thrust washer            | 45. Lock nut                |
| 13. Bulkhead locknut          | 30. Grease fitting           | 46. External retaining ring |
| 14. Bulkhead elbow union      | 31. Cutting unit pivot shaft | 47. Pin                     |
| 15. Hydraulic hose            | 32. Cap screw                | 48. Flat washer             |
| 16. Hydraulic hose            | 33. Cap screw                | 49. O-ring                  |
| 17. Hydraulic tube            |                              |                             |

## Removal



### WARNING

**Before disconnecting or performing any work on the hydraulic system, all pressure in the system must be relieved. See Relieving Hydraulic System Pressure in the General Information section.**

1. Remove rear lift cylinder from the frame and lift arm using Figure 123 as guide.
2. If hydraulic fittings are to be removed from lift cylinder, mark fitting orientation to allow correct assembly.

## Installation

1. If hydraulic fittings were removed from lift cylinder, install fittings to cylinder using marks made during the removal process to properly orientate fittings.
2. Install rear lift cylinder to the frame and lift arm using Figure 123 as guide.
3. Make sure hydraulic tank is full. Add correct oil if necessary (see Check Hydraulic System Fluid).
4. Adjust rear lift arm (see Adjust Rear Lift Arm in Chapter 7 - Cutting Units).

# Lift Cylinder Service

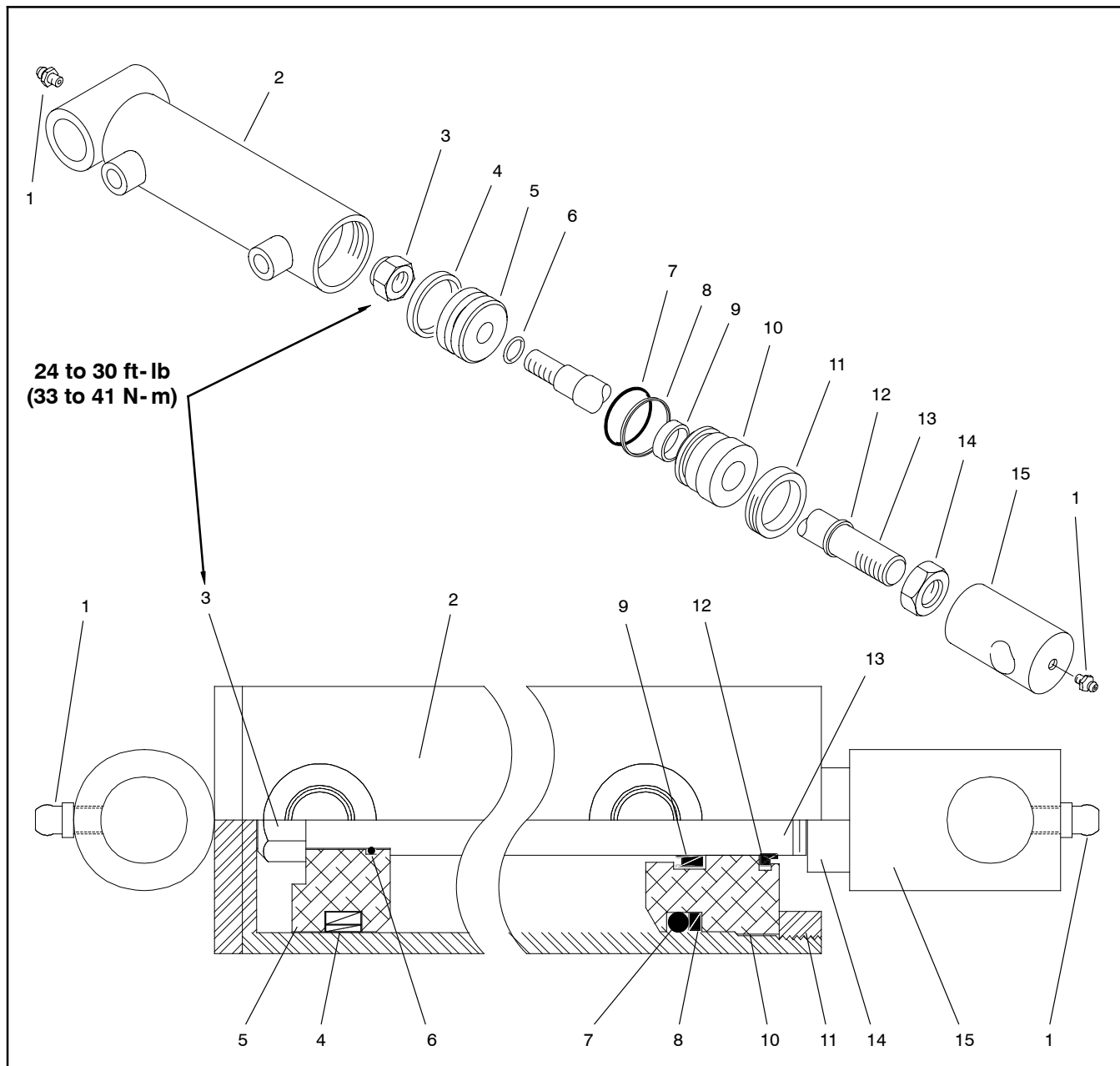

Figure 124

- 1. Grease fitting
- 2. Barrel with clevis
- 3. Nut
- 4. Uni-ring
- 5. Piston

- 6. O-ring
- 7. O-ring
- 8. Back-up ring
- 9. Rod seal
- 10. Head

- 11. Internal collar
- 12. Dust seal
- 13. Shaft
- 14. Nut
- 15. Clevis

## Disassembly

1. Remove oil from lift cylinder into a drain pan by slowly pumping the cylinder shaft. Plug both ports and clean the outside of the cylinder.

**IMPORTANT: Prevent damage when clamping the hydraulic cylinder into a vise; clamp on the clevis only.**

2. Mount lift cylinder in a vise. Remove internal collar with a spanner wrench.

3. Remove plugs from ports. Extract shaft, head, and piston by carefully twisting and pulling on the shaft.

**IMPORTANT: Do not clamp vise jaws against the shaft surface. Protect shaft surface before mounting in a vise.**

4. Mount shaft securely in a vise by clamping on the clevis of the shaft. Remove lock nut and piston from the shaft. Slide head off the shaft.

5. Remove Uni- ring and O- ring from the piston. Remove O- ring, back- up ring, rod seal, and dust seal from the head.

## Assembly

1. Make sure all parts are clean before assembly.

2. Coat new O- rings, Uni- ring, rod seal, back- up ring, and dust seal with clean hydraulic oil.

A. Install Uni- ring and O- ring to the piston.

B. Install rod seal, O- ring, back- up ring, and dust seal to the head.

**IMPORTANT: Do not clamp vise jaws against the shaft surface. Protect shaft surface before mounting in a vise.**

3. Mount shaft securely in a vise by clamping on the clevis of the shaft.

A. Coat shaft with clean hydraulic oil.

B. Slide head onto the shaft. Install rod seal onto shaft and into head.

C. Install piston and nut onto the shaft. Torque nut from 24 to 30 ft- lb (33 to 41 N- m).

D. Remove shaft from the vise.

**IMPORTANT: Prevent damage when clamping the hydraulic cylinder into a vise; clamp on the clevis only.**

4. Mount barrel in a vise.

5. Coat all internal parts with a light coat of clean hydraulic oil. Slide piston, shaft, and head assembly into the barrel being careful not to damage the seals.

6. Secure head in the barrel with internal collar using a spanner wrench. Tighten collar until snug and the outer end of the collar is flush with end of the barrel.

7. If clevis was removed from cylinder shaft, fully retract cylinder shaft and thread jam nut and clevis onto shaft. Adjust center to center length to dimension shown in Figure 125 before tightening jam nut.

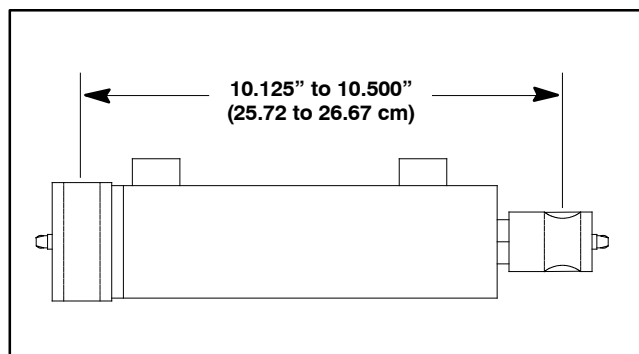
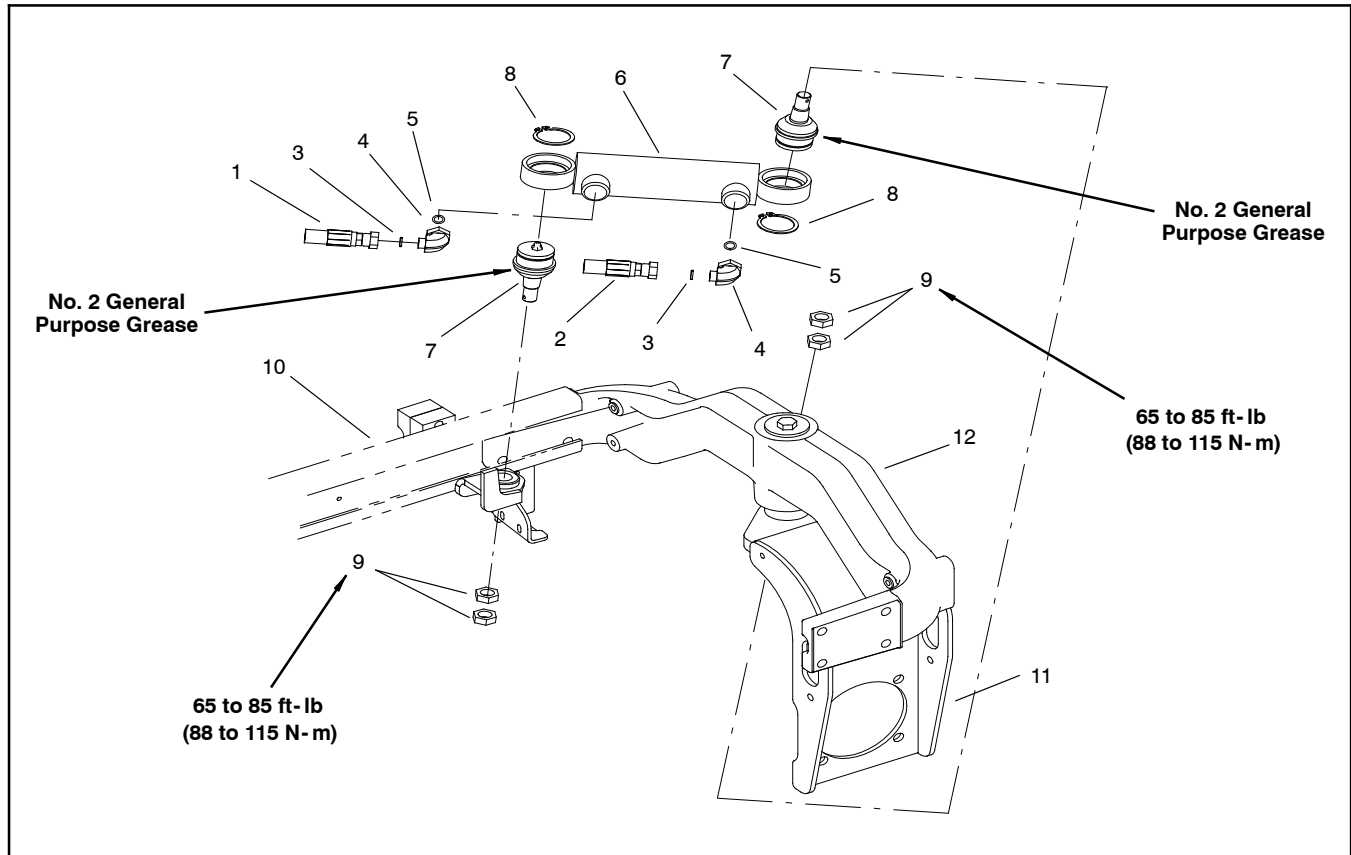

Figure 125

# Steering Cylinder



Figure

- 1. Hydraulic hose
- 2. Hydraulic hose
- 3. O-ring
- 4. Hydraulic fitting

- 5. O-ring 126
- 6. Steering cylinder
- 7. Ball joint
- 8. Retaining ring

- 9. Jam nuts
- 10. Frame
- 11. Rear fork
- 12. Rear casting



## Removal (Fig. 126)

1. Park machine on a level surface, lower cutting units, stop engine, engage parking brake and remove key from the ignition switch.

**NOTE:** The rear tire must be removed to allow sufficient clearance to remove the steering cylinder from the machine.



## WARNING

**Before jacking up the machine, review and follow Jacking Instructions in Chapter 1 - Safety.**

2. Jack or lift rear wheel off the ground.
3. Remove rear wheel from the drive studs and wheel hub.
4. Thoroughly clean hydraulic hose ends and fittings on steering cylinder to prevent hydraulic system contamination.



## WARNING

**Before disconnecting or performing any work on the hydraulic system, all pressure in the system must be relieved. See Relieving Hydraulic System Pressure in the General Information section.**

5. Remove steering cylinder from the frame and rear fork using Figure 126 as guide.
6. If hydraulic fittings are to be removed from steering cylinder, mark fitting orientation to allow correct assembly.

## Installation (Fig. 126)

1. If hydraulic fittings were removed from steering cylinder, install fittings to cylinder using marks made during the removal process to properly orientate fittings.
2. Install steering cylinder to the frame and rear fork using Figure 126 as guide. When securing cylinder ball joints to machine, tighten the first jam nut from 65 to 85 ft-lb (88 to 115 N-m), then tighten the second jam nut to the same specification.
3. Mount rear wheel to the machine with four (4) lug nuts. Lower machine to the ground. Torque lug nuts in a crossing pattern from 45 to 65 ft-lb (61 to 88 N-m).
4. Make sure hydraulic tank is full. Add correct oil if necessary (see Traction Unit Operator's Manual).

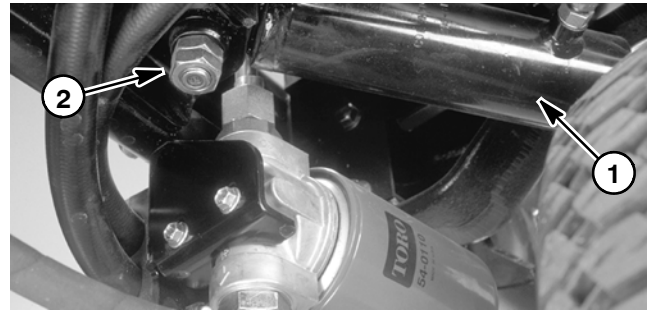

Figure 127

1. Steering cylinder
2. Jam nuts

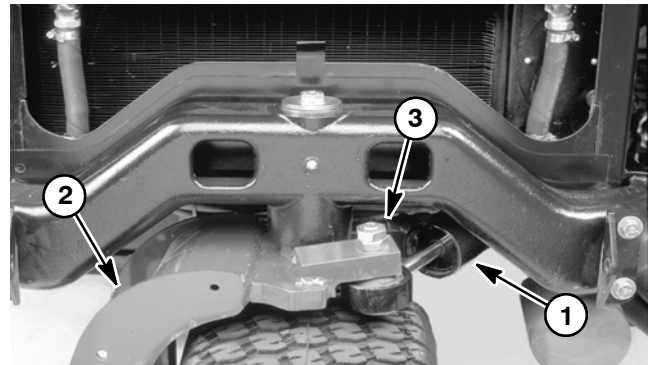

Figure 128

1. Steering cylinder
2. Rear fork
3. Jam nuts

# Steering Cylinder Service

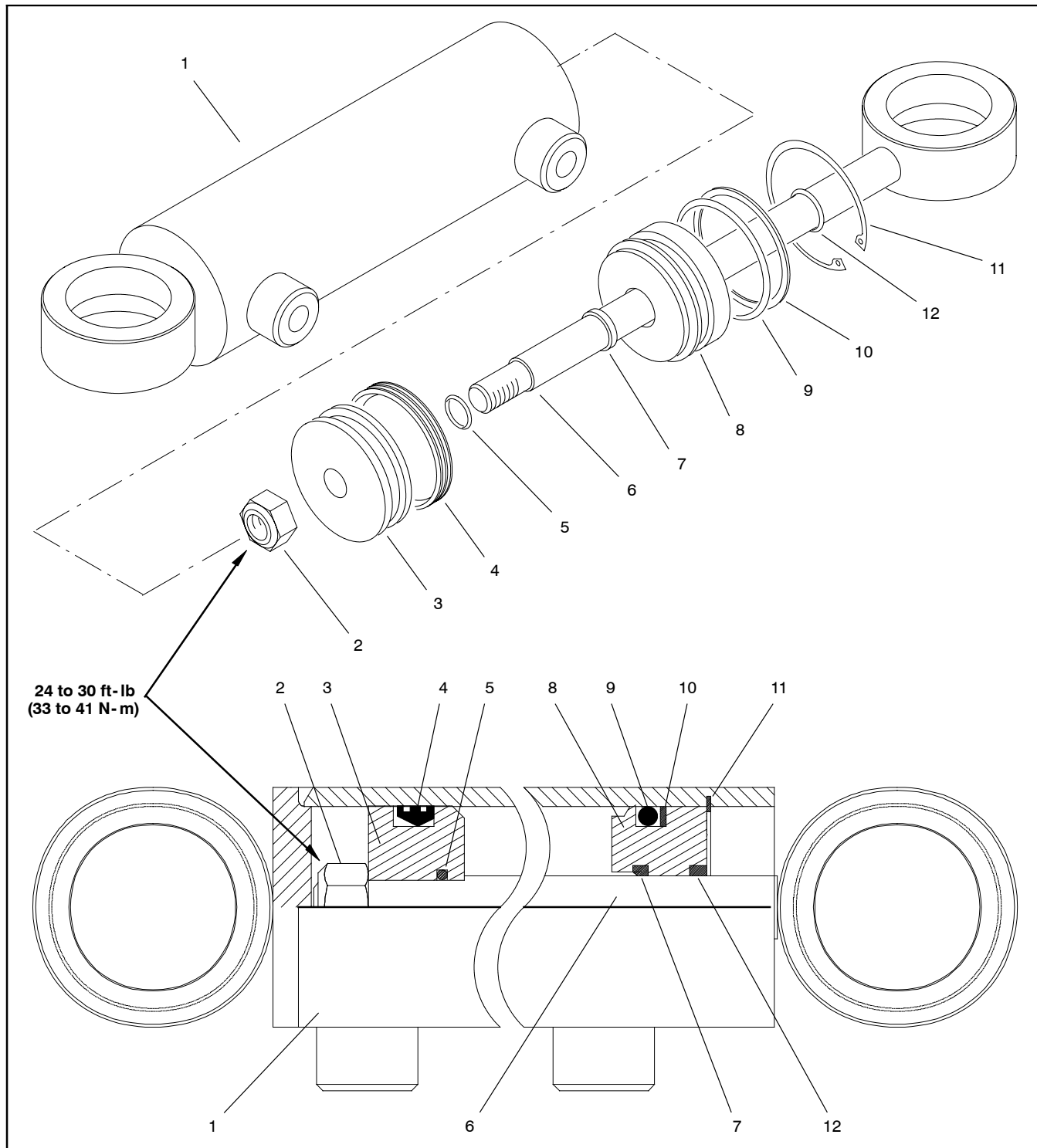

Figure 129

- 1. Barrel with clevis
- 2. Lock nut
- 3. Piston
- 4. Uni-ring

- 5. O-ring
- 6. Piston rod
- 7. Rod seal
- 8. Cylinder gland

- 9. O-ring
- 10. Back-up ring
- 11. Retaining ring
- 12. Dust seal

## Disassembly

1. Remove oil from the steering cylinder into a drain pan by slowly pumping the cylinder shaft. Plug both ports and clean the outside of the cylinder.

**IMPORTANT: Prevent damage when clamping the hydraulic cylinder into a vise; clamp on the clevis only.**

2. Mount clevis end of steering cylinder in a vice. Remove retaining ring.

3. Remove plugs from ports. Extract shaft, cylinder gland, and piston by carefully twisting and pulling on the shaft.

**IMPORTANT: Do not clamp vise jaws against the shaft surface. Protect shaft surface before mounting in a vice.**

4. Mount shaft securely in a vise by clamping on the clevis of the shaft. Remove lock nut and piston from the shaft. Slide cylinder gland off the shaft.

5. Remove Uni-ring and O-ring from the piston.

6. Remove back-up ring, O-rings, and rod seal from the cylinder gland.

## Assembly

1. Make sure all parts are clean before reassembly.

2. Coat new O-rings, Uni-ring, rod seal, and back-up ring with clean hydraulic oil.

A. Install Uni-ring and O-ring to the piston.

B. Install O-rings, back-up ring, and rod seal to the cylinder gland.

**IMPORTANT: Do not clamp vise jaws against the shaft surface. Protect shaft surface before mounting in a vice.**

3. Mount shaft securely in a vise by clamping on the clevis of the shaft.

A. Coat shaft with a light coat of clean hydraulic oil.

B. Slide cylinder gland assembly onto the shaft. Install piston and lock nut onto the shaft. Torque nut from 24 to 30 ft-lb (33 to 41 N-m).

C. Remove shaft from the vise.

**IMPORTANT: Prevent damage when clamping the hydraulic cylinder into a vise; clamp on the clevis only.**

4. Mount clevis of the barrel in a vice.

5. Coat all internal parts with a light coat of clean hydraulic oil. Slide piston, shaft, and cylinder gland assembly into the barrel being careful not to damage the seals.

6. Secure head into the barrel with the retaining ring.

This page is intentionally blank.



# Electrical System

## Table of Contents

ELECTRICAL SCHEMATICS AND DIAGRAMS . . .	2	Cutting Unit Drive Switch (Serial Number	
SPECIAL TOOLS . . . . .	3	Below 314000000) . . . . .	15
TROUBLESHOOTING . . . . .	4	Cutting Unit Drive Switch (Serial Number	
Starting Problems . . . . .	4	Above 314000000) . . . . .	15
General Run & Transport Problems . . . . .	5	Neutral Switch . . . . .	16
Cutting Deck Operating Problems . . . . .	6	Seat Switch . . . . .	16
ELECTRICAL SYSTEM QUICK CHECKS . . . . .	7	Parking Brake and Transport/Mow Switches . . .	17
Battery Test (Open Circuit Test) . . . . .	7	Fusible Link Harness . . . . .	17
Charging System Test . . . . .	7	High Temp Warning and Shutdown Switches . .	18
Glow Plug System Test . . . . .	7	Fuel Pump . . . . .	19
Check Operation of Interlock Switches . . . . .	8	Fuel Stop Solenoid (Solenoid With 3 Wire	
COMPONENT TESTING . . . . .	9	Connector) . . . . .	20
Ignition Switch . . . . .	9	Fuel Stop Solenoid (Solenoid With 2 Wire	
Glow Relay . . . . .	10	Connector) . . . . .	21
Interlock, Neutral, Seat, and High Temperature		Glow Controller . . . . .	22
Shutdown Relays . . . . .	10	Standard Control Module . . . . .	23
Hour Meter . . . . .	11	SERVICE AND REPAIRS . . . . .	24
SRV Valve Solenoid . . . . .	11	Battery Storage . . . . .	24
Diode Assemblies . . . . .	12	Battery Care . . . . .	24
Warning Light Cluster (Serial Number		Battery Service . . . . .	25
Below 240000000) . . . . .	13	Solenoid Valve Coil . . . . .	28
Indicator Lights (Serial Number Above			
240000000) . . . . .	14		

Electrical System

# Electrical Schematics and Diagrams

The electrical schematics and other electrical drawings for the Groundsmaster 3500- D are located in Chapter 8 - Electrical Diagrams.

# Special Tools

Order special tools from your Toro Distributor. Some tools may also be available from a local supplier.

## Multimeter

The meter can test electrical components and circuits for current, resistance, or voltage.

**NOTE:** Toro recommends the use of a DIGITAL Volt-Ohm-Amp multimeter when testing electrical circuits. The high impedance (internal resistance) of a digital meter in the voltage mode will make sure that excess current is not allowed through the meter. This excess current can cause damage to circuits not designed to carry it.

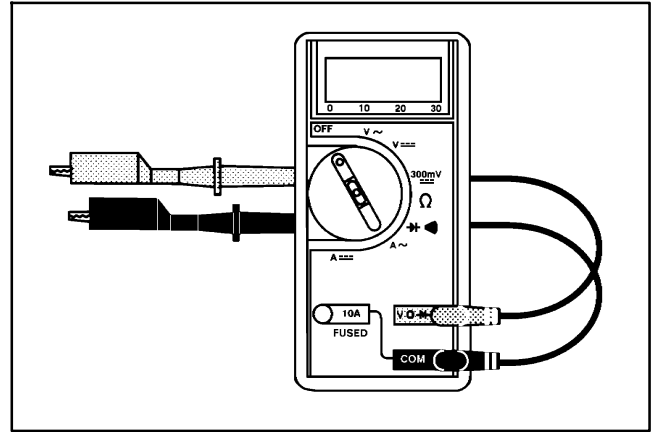

Figure 1

## Battery Terminal Protector

Battery Terminal Protector (Toro Part No. 107-0392) is an aerosol spray that should be used on battery terminals to reduce corrosion problems. Apply terminal protector after battery cable has been secured to battery terminal.



Figure 2

## Dielectric Gel

Toro Part Number: **107-0342**

Dielectric gel should be used to prevent corrosion of unsealed connection terminals. To ensure complete coating of terminals, liberally apply gel to both component and wire harness connector, plug connector to component, unplug connector, reapply gel to both surfaces and reconnect harness connector to component. Connectors should be thoroughly packed with gel for effective results.

Do not use dielectric gel on sealed connection terminals as the gel can unseat connector seals during assembly.



Figure 3

# Troubleshooting



## CAUTION

Remove all jewelry, especially rings and watches, before doing any electrical troubleshooting or testing. Disconnect the battery cables unless the test requires battery voltage.

For effective troubleshooting and repairs, you must have a good understanding of the electrical circuits and components used on this machine (see Electrical Diagrams - Chapter 8).

If the machine has any interlock switches by-passed, they must be reconnected for proper troubleshooting and safety.

## Starting Problems

Problem	Possible Causes
Starter solenoid clicks, but starter will not crank (if solenoid clicks, problem is not in safety interlock system).	Low battery charge. Loose or corroded battery cables. Loose or corroded ground. Faulty wiring at the starter. Faulty starter solenoid.
Nothing happens when start attempt is made.	The traction pedal is not in neutral position or the neutral switch is faulty. Cutting unit drive switch is in the ENGAGE position or faulty. Parking brake is disengaged with seat unoccupied. The engine is too hot or the over temperature shut down relay is faulty. The battery is dead. Fuse F1 or F3 is faulty or blown. Loose or corroded battery or ground cables. Loose or corroded ground. Wiring in the crank circuit (see Electrical Diagrams - Chapter 8) is loose, corroded, or damaged. The ignition switch is faulty. Starter solenoid wiring loose, corroded or damaged. Starter solenoid is faulty. The interlock relay is faulty.



## Starting Problems (continued)

Problem	Possible Causes
Engine cranks, but does not start.	<p>Wiring in the crank circuit (see Electrical Diagrams - Chapter 8) is loose, corroded, or damaged.</p> <p>Engine run solenoid or fuel pump is faulty.</p> <p>The fuel tank is empty. An engine or fuel system problem exists.</p> <p>The glow circuit does not operate properly.</p>
The glow circuit does not operate properly.	<p>Wiring in the glow circuit (see Electrical Diagrams - Chapter 8) is loose, corroded, or damaged.</p> <p>The glow relay or glow plug controller is faulty.</p> <p>Fuse F4 is blown or faulty.</p>
Engine cranks (but should not) with the cutting unit drive switch in the ENGAGE position.	<p>The cutting unit drive switch is faulty or short circuited.</p> <p>Short circuit in cutting unit neutral switch circuit.</p>

## General Run and Transport Problems

Engine stops running during operation (operator sitting on seat).	<p>Operator moved too far forward on seat (seat switch is not depressed).</p> <p>The engine overheated.</p> <p>The parking brake was engaged or the parking brake switch No. 1 failed.</p> <p>The seat relay or seat switch failed.</p> <p>The high temperature shutdown relay failed.</p> <p>Fuse F1 or F3 is faulty or blown.</p> <p>The run solenoid or fuel pump failed.</p> <p>Wiring in the run circuit (see Electrical Diagrams - Chapter 8) is broken or disconnected.</p>
Battery does not charge.	<p>Loose or broken wire(s).</p> <p>Faulty alternator.</p> <p>Dead battery.</p> <p>Alternator warning lamp is faulty or burned out.</p> <p>Alternator warning lamp wiring is loose, corroded or damaged.</p>

## Cutting Deck Operating Problems

<p>The cutting units will not run with the mow/transport slide in MOW and the cutting unit drive switch in ENGAGE with the rotary decks lowered.</p>	<p>Wiring to the cutting unit drive circuit (see Electrical Diagrams - Chapter 8) is loose, corroded, or damaged.</p> <p>Fuse F4 is faulty or blown.</p> <p>The SRV coil (R1) on the hydraulic manifold is faulty or the valve is stuck.</p> <p>The cutting unit drive switch is faulty.</p> <p>The cutting unit up limit or mow/transport slide is faulty or misadjusted.</p> <p>There is insufficient hydraulic oil pressure to turn the cutting units (see Troubleshooting in Chapter - 4- Hydraulic System).</p>
<p>The cutting units run, but should not run, when raised.</p>	<p>The SRV coil (R1) on the hydraulic manifold is faulty or the valve is stuck.</p>

# Electrical System Quick Check

## Battery Test (Open Circuit Test)

Use a multimeter to measure the voltage between the battery terminals.

Set multimeter to the DC volts setting. The battery should be at a temperature of 60° to 100°F (16° to 38°C). The ignition key should be off and all accessories turned off. Connect the positive (+) meter lead to the positive battery post and the negative (-) meter lead to the negative battery post.

**NOTE:** This test provides a relative condition of the battery. Load testing of the battery will provide additional and more accurate information.

Voltage Measured	Battery Charge Level
12.68 V (or higher)	Fully charged (100%)
12.45 V	75% charged
12.24 V	50% charged
12.06 V	25% charged
11.89 V	0% charged

## Charging System Test

This is a simple test used to determine if a charging system is functioning. It will tell you if the charging system has an output, but not its capacity.

Tool required: Digital multimeter set to DC volts.

Test instructions: Connect the positive (+) multimeter lead to the positive battery post and the negative (-) multimeter lead to the negative battery post. Keep the test leads connected to the battery posts and record the battery voltage.

**NOTE:** Upon starting the engine, the battery voltage will drop and then should increase once the engine is running.

**NOTE:** Depending upon the condition of the battery charge and battery temperature, the charging system voltage will increase at different rates as the battery charges.

Start the engine and run at high idle (3200 RPM). Allow the battery to charge for at least 3 minutes. Record the battery voltage.

After running the engine for at least 3 minutes, battery voltage should be at least 0.50 volt higher than initial battery voltage.

Example of a charging system that is functioning:

At least 0.50 volt over initial battery voltage.	
Initial Battery Voltage	= 12.30 v
Battery Voltage after 3 Minute Charge	= 12.95 v
Difference	= +0.65 v

## Glow Plug System Test

This is a fast, simple test that can help to determine the integrity and operation of the Groundsmaster 3500- D glow plug system. The test should be run anytime hard starting (cold engine) is encountered on a diesel engine equipped with a glow plug system.

Tool(s) required: Digital multimeter and/or inductive Ammeter (AC/DC Current Transducer).

Test instructions: Properly connect the ammeter to the digital multimeter (refer to manufacturers' instructions).

Set the multimeter to the correct scale. With the ignition switch in the OFF position, place the ammeter pickup around the main glow plug power supply wire and read the meter prior to activating the glow plug system. Adjust the meter to read zero (if applicable). Activate the glow plug system (see Traction Unit Operator's Manual) and record the multimeter results.

The Groundsmaster 3500- D glow plug system should have a reading of approximately 27 Amps.

---

## Check Operation of Interlock Switches



### CAUTION

**The interlock switches are for the operator's protection; do not disconnect them. Check the operation of the interlock switches daily for proper operation. Replace any malfunctioning switches before operating the machine.**

**NOTE:** The machine is equipped with an interlock switch on the parking brake. The engine will stop if the traction pedal is depressed with the parking brake engaged.

1. Make sure all bystanders are away from the area of operation. Keep hands and feet away from rotary decks.

2. With operator on the seat, the engine must not start with either the cutting unit drive switch in the ENGAGE position or the traction pedal engaged. Correct problem if not operating properly.

3. With operator on the seat, the traction pedal in neutral, the parking brake off, and the cutting unit drive switch in the DISENGAGE position, the engine should start. Lift off the seat and slowly depress traction pedal, the engine should stop in one to three seconds. Correct problem if not operating properly.

# Component Testing

For accurate resistance and/or continuity checks, electrically disconnect the component being tested from the circuit (e.g. unplug the ignition switch connector before doing a continuity check on the switch).

**NOTE:** For more component testing information, see the Kubota Workshop Manual, Diesel Engine, 05 Series.

CAUTION

**When testing electrical components for continuity with a multimeter (ohms setting), make sure that power to the circuit has been disconnected.**

## Ignition Switch

The ignition (key) switch has three positions (OFF, ON/PREHEAT, and START). The terminals are marked as shown. The circuitry of the ignition switch is shown in the chart below. With the use of a multimeter (ohms setting), the switch functions may be tested to determine whether continuity exists between the various terminals for each position. Verify continuity between switch terminals.

SWITCH POSITION	NORMAL CIRCUITS	OTHER CIRCUITS
OFF	NONE	NONE
ON/PREHEAT	B + A + I	X + Y
START	B + S + I	NONE

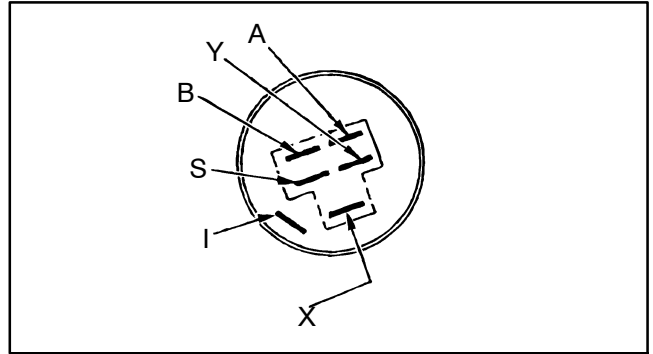

Figure 4

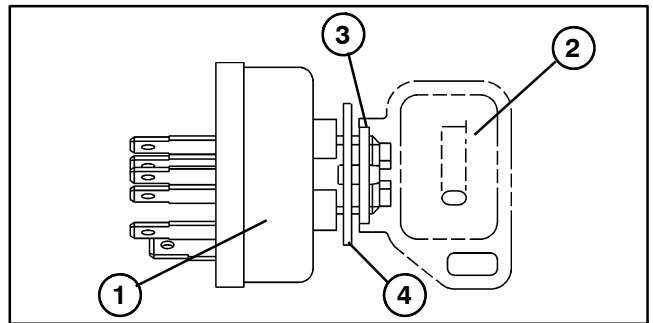

Figure 5

- |           |                |
|-----------|----------------|
| 1. Switch | 3. Hex nut     |
| 2. Key    | 4. Lock washer |

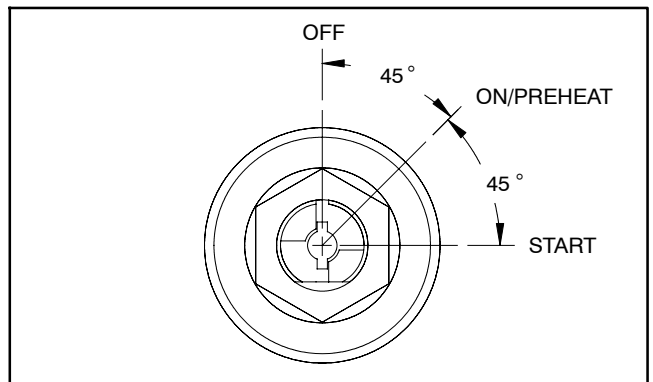

Figure 6

Electrical System

## Glow Relay

The glow relay is attached to the radiator assembly. When energized, the glow relay allows electrical current to the engine glow plugs.

Two styles of glow relays have been used on the Groundsmaster 3500- D. On machines with serial numbers below 240000000, two of the four relay connections are secured with screws (Fig. 7). On machines with serial numbers above 240000000, the glow relay is attached to the wire harness with a four wire connector (Fig. 8).

1. Verify coil resistance between terminals 86 and 85 with a multimeter (ohms setting).

A. On machines with serial numbers below 240000000, resistance should be from 41 to 51 ohms.

B. On machines with serial numbers above 240000000, resistance should be approximately 72 ohms.

2. Connect multimeter (ohms setting) leads to relay terminals 30 and 87. Ground terminal 86 and apply +12 VDC to terminal 85. The relay should make and break continuity between terminals 30 and 87 as +12 VDC is applied and removed from terminal 85.

3. Disconnect voltage and leads from the terminals.

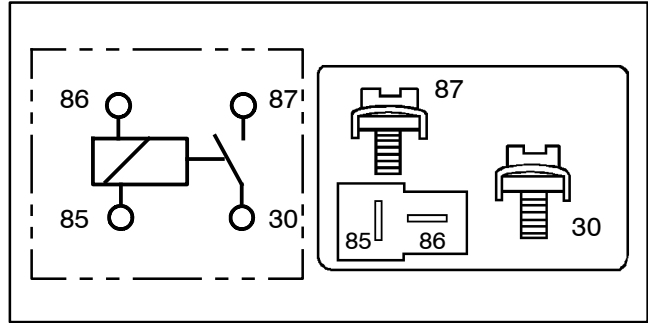

Figure 7

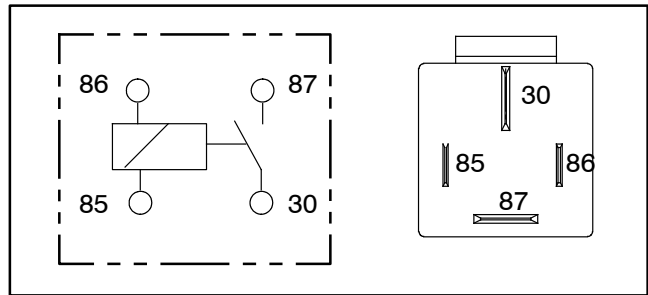

Figure 8

## Interlock, Neutral, Seat, and High Temperature Shutdown Relays

These relays are located in the control panel on machines with Serial Numbers below 240000000.

1. Verify coil resistance between terminals 86 and 85 with a multimeter (ohms setting). Resistance should be from 80 to 90 ohms. There should be continuity between terminals 87A and 30.

2. Connect multimeter (ohms setting) leads to relay terminals 30 and 87. Ground terminal 86 and apply +12 VDC to terminal 85. The relay should make and break continuity between terminals 30 and 87 as +12 VDC is applied and removed from terminal 85.

3. Disconnect voltage from terminal 85 and multimeter lead from terminal 87.

4. Connect multimeter (ohms setting) leads to relay terminals 30 and 87A. Apply +12 VDC to terminal 85. The relay should make and break continuity between terminals 30 and 87A as +12 VDC is applied and removed from terminal 85.

5. Disconnect voltage and multimeter leads from the relay terminals.

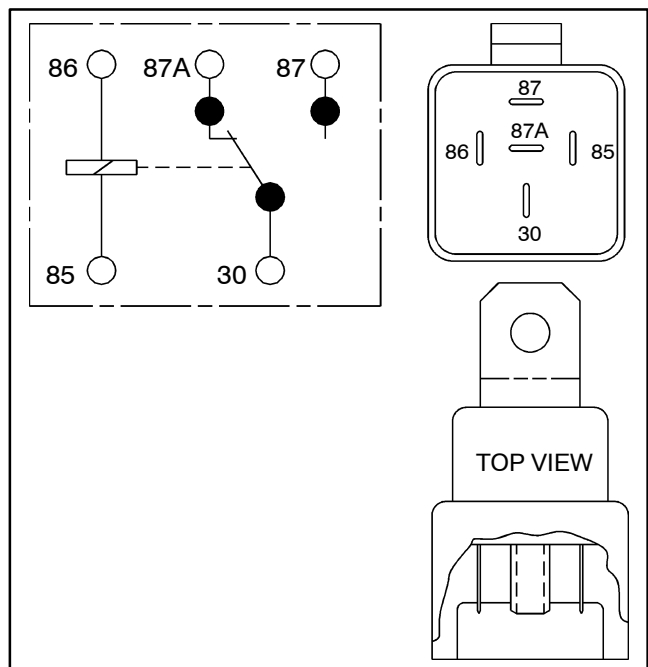

Figure 9

## Hour Meter

1. Connect the positive (+) terminal of a 12 VDC source to the positive terminal of the hour meter.
2. Connect the negative (-) terminal of the voltage source to the other terminal of the hour meter.
3. The hour meter should move 1/10 of an hour in six minutes.
4. Disconnect the voltage source from the hour meter.

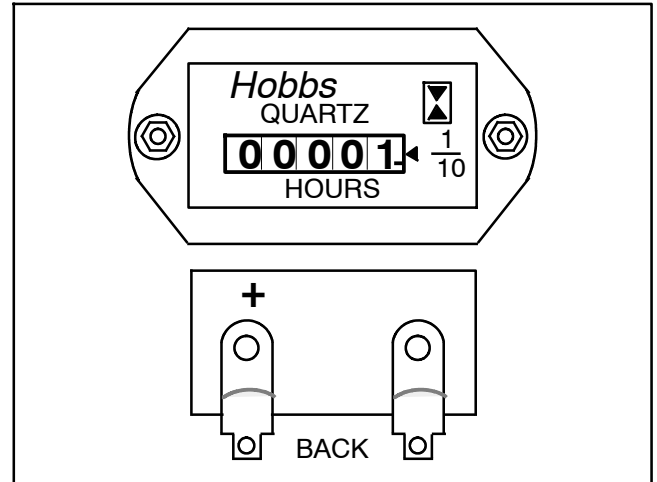

Figure 10

## SRV Valve Solenoid

The hydraulic system on the Groundsmaster 3500-D uses a solenoid valve coil on the hydraulic manifold (Fig. 12). When the solenoid valve coil is energized, spool shift in the valve will direct hydraulic flow to the cutting decks.

Two versions of solenoid coils have been used on the Groundsmaster 3500-D. Earlier coils had a short harness with a two pin connector (Fig. 11). Later coils use a connector incorporated into the coil body (Fig. 12). Function and testing of the coils is the same.

### Testing

1. Make sure engine is off. Disconnect wire harness electrical connector from the solenoid valve coil.

**NOTE:** Prior to taking small resistance readings with a digital multimeter, short the test leads together. The meter will display a small resistance value (usually 0.5 ohms or less). This resistance is due to the internal resistance of the meter and test leads. Subtract this value from the measured value of the component you are testing.

2. Measure resistance between the two connector terminals on the solenoid coil. The resistance should be approximately 7.2 ohms.
3. Reconnect electrical connector to the solenoid.
4. If solenoid coil needs replacement, see PTO Solenoid Valve Coil in the Service and Repairs section of this chapter.

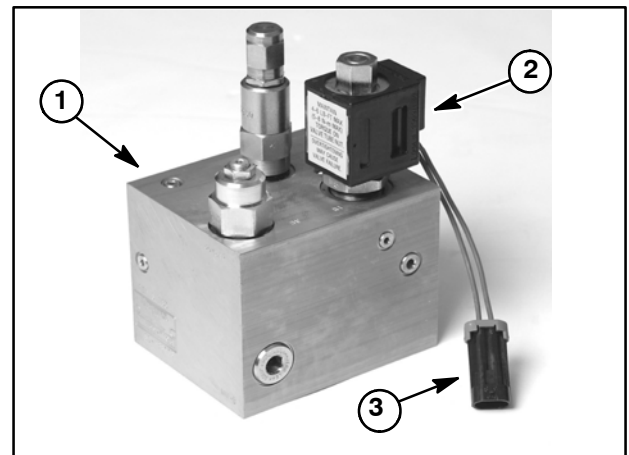

Figure 11

1. Manifold assembly
2. Solenoid valve
3. Coil connector

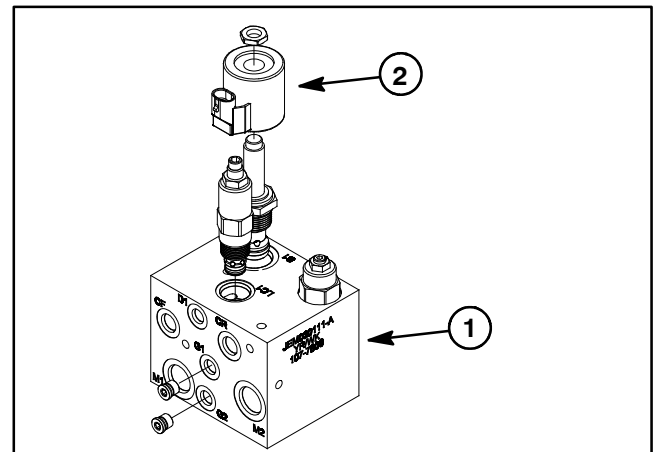

Figure 12

1. Manifold assembly
2. Solenoid valve coil

## Diode Assemblies

The diodes D1, D2, and D4 provide logic for the interlock switches. Diode D3 is used for circuit protection from inductive voltage spikes when the interlock relay is de-energized. Two types of diodes have been used on the Groundsmaster 3500-D:

1. On early production machines, the diodes are located within the main wiring harness that lies under the hydraulic tank and control console (Fig. 13).
2. Later production machines use diodes that plug into the wiring harness (Fig. 14). Location of the diodes is under the control console.

**NOTE:** Machines equipped with the standard control module (serial numbers above 240000000) use only one diode.

### Testing

The diodes can be individually tested using a digital multimeter (diode test or ohms setting) and the tables below.

1. Diodes located within the main harness (Fig. 13):

Multimeter Red Lead (+) on Terminal Blade	Multimeter Black Lead (-) on Terminal Blade	Continuity
Male	Female	YES
Female	Male	NO

2. Plug-in style diodes (Fig. 14):

Multimeter Red Lead (+) on Terminal	Multimeter Black Lead (-) on Terminal	Continuity
Female	Male	YES
Male	Female	NO

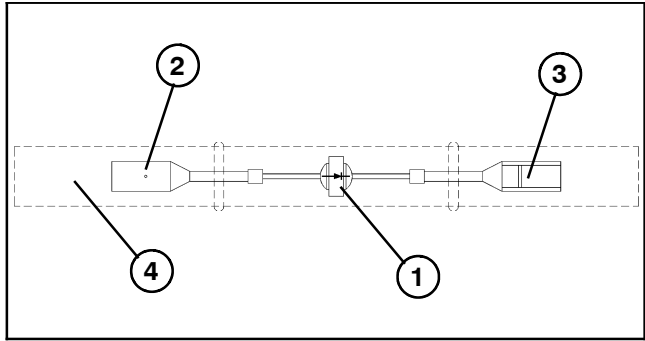

Figure 13

1. Diode
2. Male terminal blade
3. Female terminal blade
4. Clear PVC tubing

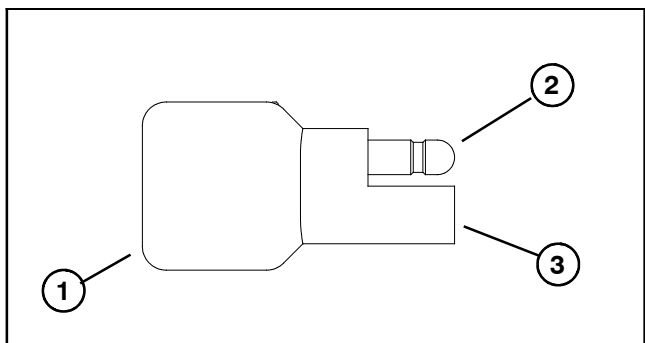

Figure 14

1. Diode
2. Male terminal
3. Female terminal



## Warning Light Cluster (Serial Numbers Below 24000000)

**NOTE:** Individual light bulbs can be tested by removing them from the lighting cluster and applying 12 VDC to their wiring terminals.

### Oil Pressure Light

The oil pressure light should come on when the ignition switch is in the ON/PREHEAT position with the engine not running. Also, it should light with the engine running when the oil pressure drops below 7 PSI (0.4 kg/cm<sup>2</sup>).

1. Disconnect gray wire from the oil pressure switch.
2. Ground gray wire to the engine block.
3. Turn the ignition switch to ON/PREHEAT; the light should come on.
4. Turn the ignition switch to OFF. Connect gray wire to the oil pressure switch.

### High Temperature (Water) Warning Light

When the coolant temperature is above 221°F (105°C), the high temperature light should come on. However, the high temperature shutdown switch and relay do not stop the engine until the coolant temperature is above 230°F (110°C).

### Glow Light

The glow light should come on when the ignition switch is placed in ON/PREHEAT prior to placing the ignition switch in START. The glow light stays on for 10 seconds while left in ON/PREHEAT.

### Battery Light

The battery light should come on when the ignition switch is in the ON/PREHEAT position with the engine not running, or with an improperly operating charging circuit while the engine is running.

1. Turn ignition switch to ON/PREHEAT; the battery light should come on.
2. Turn ignition switch to OFF.

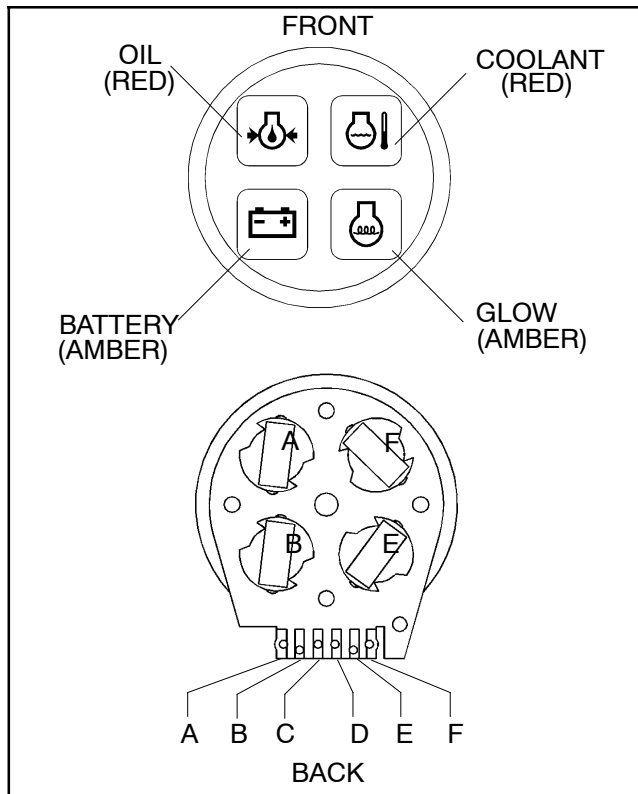

Figure 15

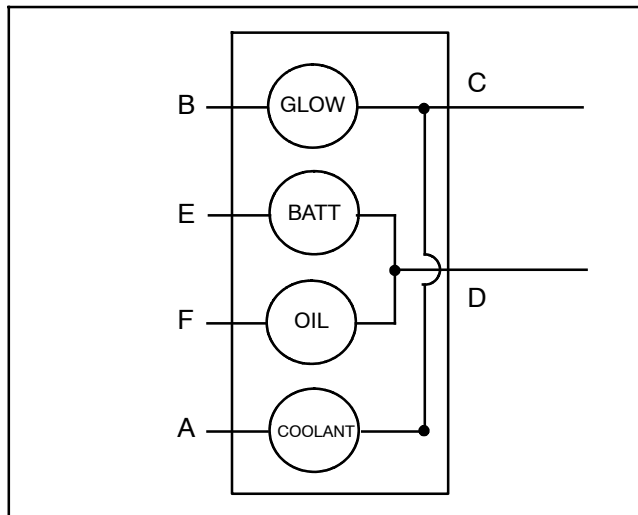

Figure 16

## Indicator Lights (Serial Numbers Above 24000000)

### Charge Indicator Light

The charge indicator light should come on when the ignition switch is in the ON position with the engine not running. Also, it should illuminate with an improperly operating charging circuit while the engine is running.

### Engine Oil Pressure Light

The engine oil pressure light should come on when the ignition switch is in the ON position with the engine not running. Also, it should illuminate with the engine running if the engine oil pressure drops to an unsafe level.

**IMPORTANT: If the oil pressure indicator light is illuminated with the engine running, shut off the engine immediately.**

To test the oil pressure light and circuit wiring, ground the wire attached to oil pressure switch located on the engine near the oil filter. Turn ignition switch to the ON position; the engine oil pressure light should come on indicating correct operation of the indicator light and circuit wiring.

### High Temperature Warning Light

If the engine coolant temperature reaches 221°F (105°C) (approximate), the high temperature warning light should come on.

To test the high temperature warning light and circuit wiring, turn ignition switch to the ON position and ground the gray wire attached to high temperature sender located on the engine water pump housing (see Temperature Sender in this Chapter). The high temperature warning light should illuminate.

### Glow Plug Indicator Light

The glow plug light should come on when the ignition switch is placed in the ON position prior to placing the ignition switch in START. The light should stay lit for approximately 6 seconds while the ignition switch is left in the ON position.

### Testing Indicator Lights

1. Apply 12 VDC to terminals 1A and 2A (Fig. 18).
2. Ground terminals 1B and 2B (Fig. 18).
3. Both indicator lights should illuminate.

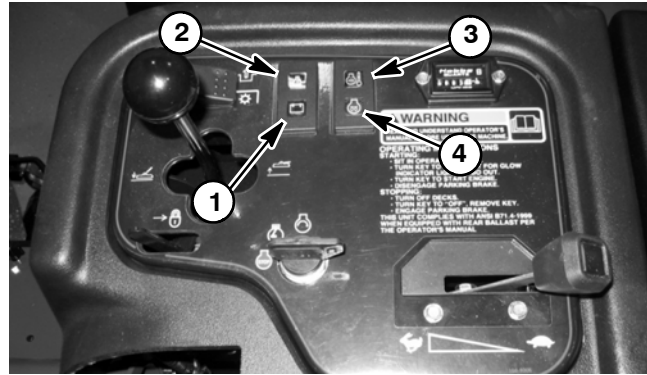

Figure 17

1. Charge indicator
2. Engine oil pressure
3. High temp shutdown
4. Glow plug indicator

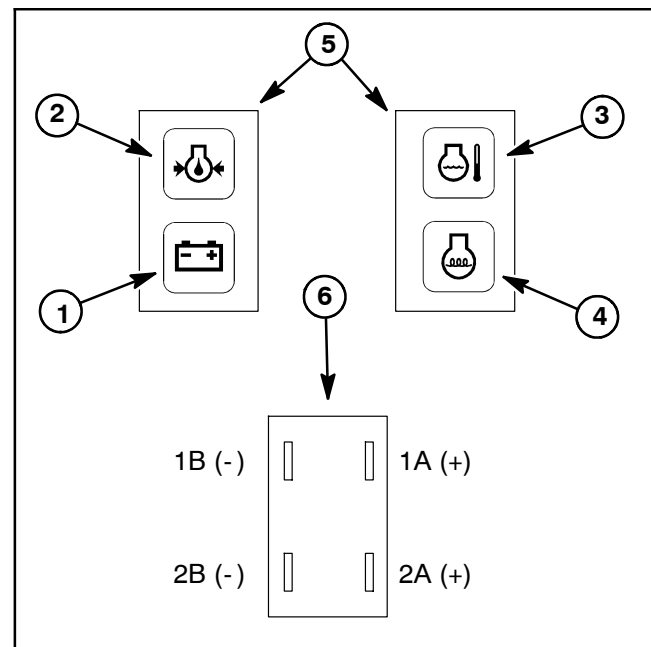

Figure 18

1. Charge indicator
2. Engine oil pressure
3. High temperature
4. Glow plug indicator
5. Indicator light front
6. Indicator light back

## Cutting Unit Drive Switch (Serial Number Below 314000000)

The cutting unit drive switch is located on the control panel (Fig. 19). This switch allows the decks to be engaged or disengaged. Along with additional switches in the interlock system, the cutting unit drive switch controls the solenoid valve on the hydraulic manifold. The cutting unit drive switch used on machines with serial number below 314000000 is a six (6) terminal rocker switch.

The switch terminals are marked as shown in Fig. 20. The circuitry of the ignition switch is shown in the chart below. With the use of a multimeter (ohms setting), the switch functions may be tested to determine whether continuity exists between the various terminals for each position. Verify continuity between switch terminals.

SWITCH POSITION	NORMAL CIRCUITS	OTHER CIRCUITS
ENGAGE	5 + 6	2 + 3
DISENGAGE	1 + 2	4 + 5

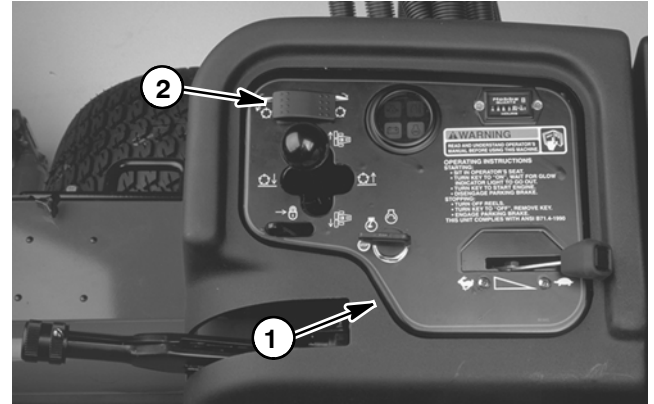

Figure 19

1. Control panel      2. Cutting unit drive switch

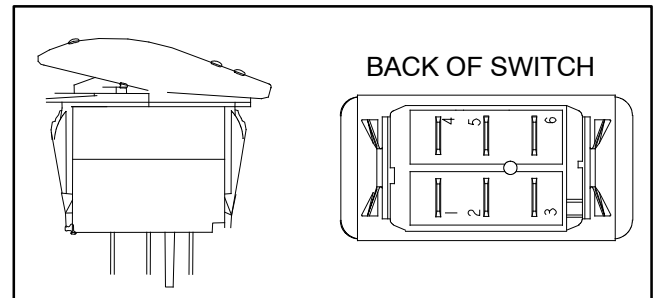

Figure 20

## Cutting Unit Drive Switch (Serial Number Above 314000000)

The cutting unit drive switch is located on the control panel and allows the decks to be engaged or disengaged. Along with additional switches in the interlock system, the cutting unit drive switch controls the solenoid valve on the hydraulic manifold. The cutting unit drive switch used on machines with serial number above 314000000 is a six (6) terminal switch that is illustrated in Fig. 21.

The switch terminals are marked as shown in Fig. 21. The circuitry of the ignition switch is shown in the chart to the right. With the use of a multimeter (ohms setting), the switch functions may be tested to determine whether continuity exists between the various terminals for each position. Verify continuity between switch terminals.

**NOTE:** Only cutting unit drive switch terminals COM C and NO C are used on Groundsmaster 3500-D machines.

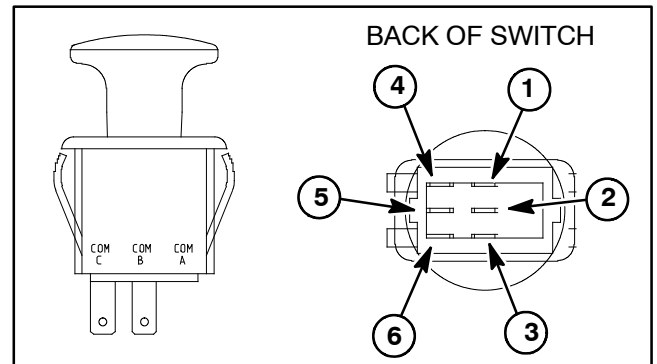

Figure 21

1. COM B terminal      4. COM C terminal  
2. NO B terminal      5. NO C terminal  
3. NC B terminal      6. NC C terminal

SWITCH POSITION	CLOSED CIRCUITS	OPEN CIRCUITS
OFF (DOWN)	COM B + NC B COM C + NC C	COM B + NO B COM C + NO C
ON (UP)	COM B + NO B COM C + NO C	COM B + NC B COM C + NC C

---

## Neutral Switch

The neutral switch is a proximity type, normally open reed switch that closes when the traction pedal is in the neutral position. The neutral switch is located under the floor support plate.

1. Disconnect electrical connector from the neutral switch.
2. Check the continuity of the switch by connecting a multimeter (ohms setting) across the connector terminals.
3. With the traction pedal in the neutral position, there should be continuity between the two switch leads.
4. Slowly depress the traction pedal. The continuity tester should show no continuity as the pedal is moved in either the forward or reverse direction.
5. Reconnect switch after testing.

6. Switch adjustment: neutral switch should be installed so that the pin on the traction pedal (neutral position) is centered with the switch.

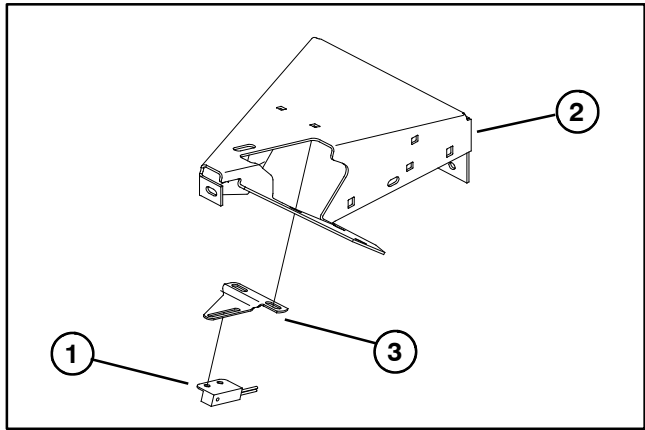

Figure 22

1. Neutral switch
2. Floor support plate
3. Switch bracket

---

## Seat Switch

The seat switch is normally open and closes when the operator is on the seat. If the neutral switch or traction interlock switch is open when the operator raises out of the seat, the engine will stop.

The standard seat uses a switch that is fastened to the underside of the seat (Fig. 23). The deluxe seat has a switch that is mounted to the seat base under the cushion. The switch electrical connector for either seat type is located directly under the seat. Testing is the same for either switch type:

1. Make sure the engine is off. Remove seat by removing four cap screws that secure seat mounting straps to traction unit.
2. Disconnect electrical connector from the switch.
3. Check the continuity of the switch by connecting a multimeter (ohms setting) across the connector terminals.
4. With no pressure on the seat, there should be no continuity between the seat switch terminals.
5. Press directly onto the seat switch through the seat cushion. There should be continuity as the seat cushion approaches the bottom of its travel.
6. Reconnect switch connector. Reinstall seat assembly.

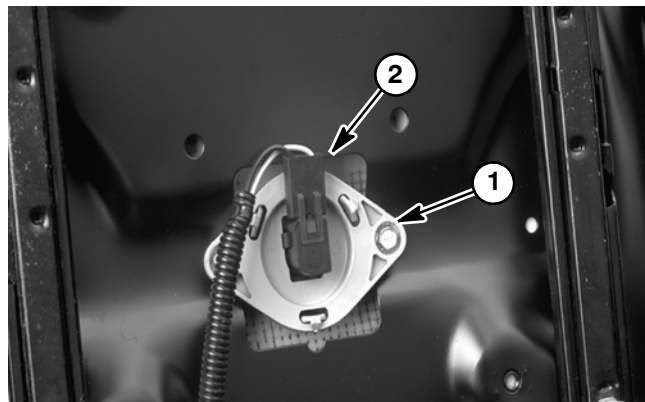

Figure 23

1. Standard seat switch
2. Electrical connector

## Parking Brake and Transport/Mow Switches

The switches used for the parking brake and transport/mow are the same, normally closed switch. The parking brake switch is located under the dash cover and opens when the parking brake lever is engaged. The transport/mow switch is located under the floor plate and opens when the transport/mow slide is in the transport position.

1. Make sure the engine is off. Locate switch for testing.
2. Disconnect electrical connector from the switch.
3. Check the continuity of the switch by connecting a multimeter (ohms setting) across the connector terminals.
4. When the switch plunger is extended there should be continuity between the switch terminals.
5. When the switch plunger is depressed, there should be no continuity between the switch terminals.
6. Reconnect switch connector.

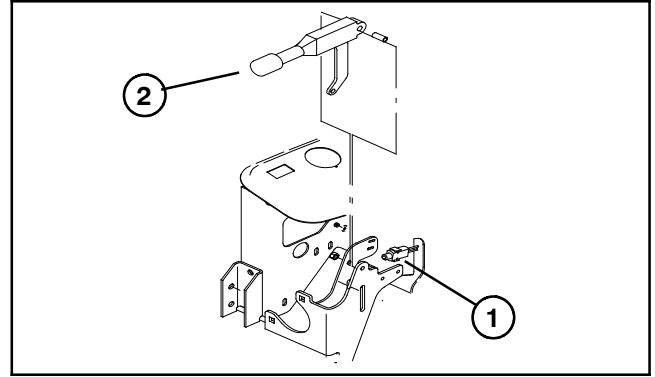

Figure 24

1. Parking brake switch      2. Parking brake lever

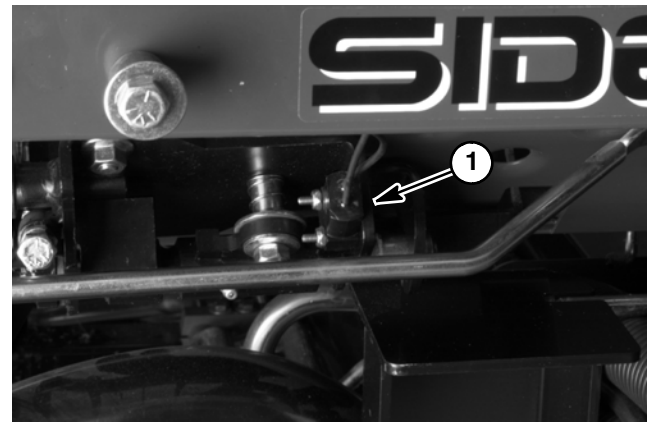

Figure 25

1. Transport/Mow switch

## Fusible Link Harness

The Groundsmaster 3500- D uses three (3) fusible links for circuit protection. These fusible links are located in a harness that connects the starter B+ terminal to the main wire harness. If any of these links should fail, current to the protected circuit will cease. Refer to wire harness drawings in Chapter 8 - Electrical Diagrams for additional fusible link information.

Use a multimeter to make sure that continuity exists between each terminal pin in connector P1 and connector J1 at the starter (Fig. 26). If any of the fusible links are open, replace the complete harness.

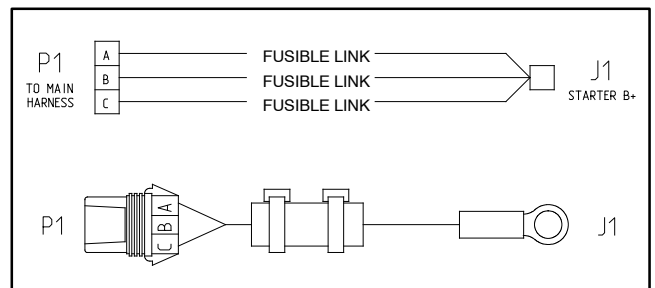

Figure 26

## High Temperature Warning and Shutdown Switches

The high temperature warning and shutdown switches are located on the water pump housing, which is located on the rear end of the engine block. The high temperature shutdown switch is on the alternator side of the engine (Fig. 27).



### CAUTION

**Make sure engine is cool before removing the temperature switch.**

1. Lower coolant level in the engine and remove the temperature switch.
2. Put switch in a container of oil with a thermometer and slowly heat the oil (Fig. 28).



### CAUTION

**Handle the hot oil with extreme care to prevent personal injury or fire.**

3. Check continuity of the switch with a multimeter (ohms setting).
  - A. The high temperature warning switch is normally open and should close between 216 to 226°F (102 to 108°C).
  - B. The high temperature shutdown switch is normally open and should close between 225 to 235°F (107 to 113°C).
4. Allow oil to cool while observing temperature.
  - A. The high temperature warning switch should open at about 208°F (98°C).
  - B. The high temperature shutdown switch should open at about 219°F (104°C).
5. Replace switch if necessary.

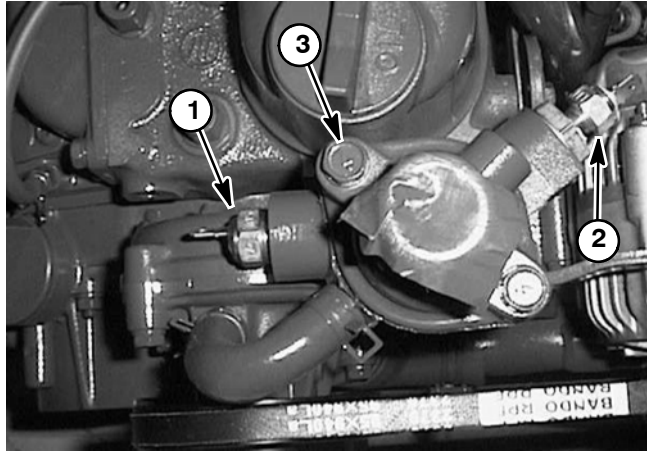

Figure 27

1. Temp. warning switch
2. Temp. shutdown switch
3. Water pump housing

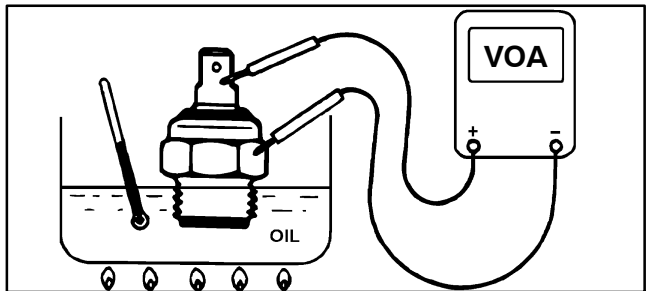

Figure 28

## Fuel Pump

The fuel pump is attached to the frame just outboard of the fuel injection pump.

### Operational Test

1. Park machine on a level surface, lower cutting decks, stop engine, and engage parking brake. Unlatch and raise hood.
2. Disconnect electrical connector from the fuel stop solenoid to prevent the engine from firing.
3. Disconnect fuel hose (pump discharge) from the fuel filter.
4. Make sure fuel hoses attached to the fuel pump are free of obstructions.
5. Place fuel hose (pump discharge) into a large, graduated cylinder sufficient enough to collect 1 quart (0.95 liter).

**IMPORTANT: When testing the fuel pump, DO NOT turn ignition switch to START.**

6. Collect fuel in the graduated cylinder by turning ignition switch to the RUN position. Allow pump to run for time listed below, then return switch to OFF.
  - A. For most Groundsmaster 3500- D machines, the amount of fuel collected in the graduated cylinder should be approximately **11.8 fl oz (350 ml) after thirty (30) seconds.**
  - B. For machines that are equipped with a Biodiesel Conversion Kit, the amount of fuel collected in the graduated cylinder should be approximately **16 fl oz (475 ml) after fifteen (15) seconds.**

7. Replace fuel pump as necessary. Install fuel hose to the fuel filter.
8. Reconnect electrical connector to the fuel stop solenoid.
9. Bleed fuel system.

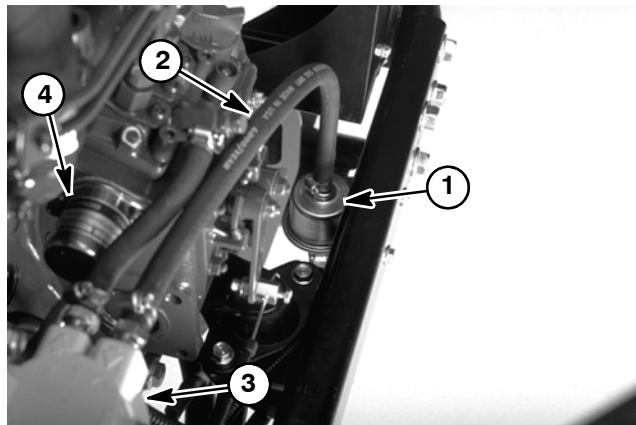

Figure 29

1. Fuel pump
2. Fuel hose (discharge)
3. Fuel filter
4. Fuel stop solenoid

### Fuel Pump Specifications

Pump Capacity	23.5 fl oz/min (695 ml/min)
Pressure	3.3 psi (22.8 kPa)
Max. Current Draw	0.9 amp

**Note:** Fuel pump specifications for machines equipped with a Biodiesel Conversion Kit are as follows:

Pump Capacity	64 fl oz/min (1.9 liters/min)
Pressure	7 PSI (48.3 kPa)
Current Draw	2.0 amp

## Fuel Stop Solenoid (Solenoid With 3 Wire Connector)

The fuel stop solenoid must be energized for the engine to run. It is mounted on the engine block near the injection pump.

The fuel stop solenoid includes two coils for operation: the pull coil and the hold coil. When the ignition switch is turned to START, the fuel stop solenoid is initially energized and the pull coil retracts the solenoid plunger. Once the plunger is retracted, the hold coil will keep it retracted for continued engine operation. When the solenoid is de-energized, the plunger extends to shut off fuel supply to the engine causing the engine to stop running. The fuel stop solenoid is grounded through the common (black) wire of the solenoid wire connector.

**NOTE:** Refer to Chapter 8 - Electrical Diagrams when troubleshooting the fuel stop solenoid.

### Testing

**NOTE:** Prior to taking small resistance readings with a digital multimeter, short the test leads together. The meter will display a small resistance value (usually 0.5 ohms or less). This resistance is due to the internal resistance of the meter and test leads. Subtract this value from the measured value of the component you are testing.

1. Make sure ignition switch is in the OFF position. Disconnect the connector from the solenoid.
2. Using a digital multimeter, touch one test lead to the pin of the **black** wire and the other test lead to the pin of the **white** wire (Fig. 31). The resistance of the **pull coil** should be about 0.33 ohms.
3. Using a digital multimeter, touch one test lead to the pin of the **black** wire and the other test lead to the pin of the **red** wire (Fig. 31). The resistance of the **hold coil** should be about 12.2 ohms.
4. Connect solenoid to the wiring harness.

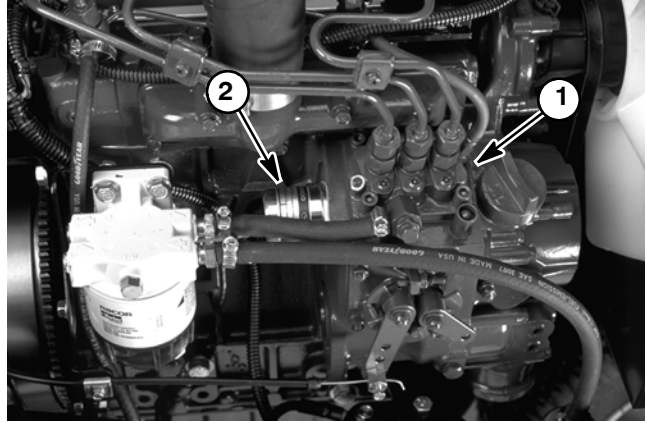

Figure 30

1. Injection pump
2. Fuel stop solenoid

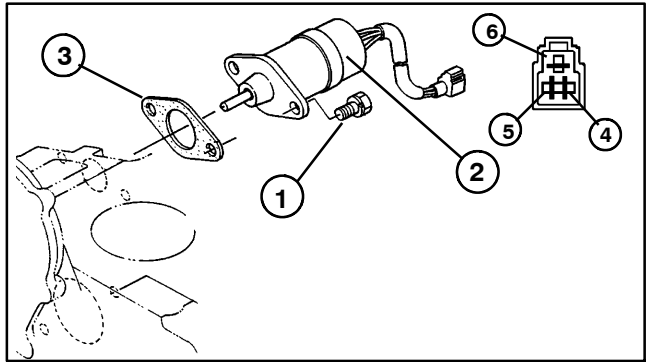

Figure 31

1. Cap screw
2. Fuel stop solenoid
3. Gasket
4. Common (Black wire)
5. Hold coil (Red wire)
6. Pull coil (White wire)



## Fuel Stop Solenoid (Solenoid With 2 Wire Connector)

The fuel stop solenoid used on the Groundsmaster 3505- D must be energized for the diesel engine to run. The solenoid is mounted to the injection pump on the engine (Fig. 32).

The fuel stop solenoid includes two coils for operation: the pull coil and the hold coil. When the ignition switch is turned to START, the fuel stop solenoid is initially energized and the pull coil retracts the solenoid plunger. Once the plunger is retracted, the hold coil will keep it retracted for continued engine operation. When the solenoid is de- energized, the plunger extends to shut off fuel supply to the engine causing the engine to stop running. The fuel stop solenoid is grounded through the solenoid housing.

**NOTE:** Refer to Chapter 8 - Electrical Diagrams when troubleshooting the fuel stop solenoid.

### In Place Testing

**NOTE:** Prior to taking small resistance readings with a digital multimeter, short the test leads together. The meter will display a small resistance value (usually 0.5 ohms or less). This resistance is due to the internal resistance of the meter and test leads. Subtract this value from the measured value of the component you are testing.

1. Make sure ignition switch is in the OFF position. Disconnect wire harness connector from fuel stop solenoid.
2. Using a digital multimeter, touch one test lead to the pull coil terminal and the other test lead to the fuel stop solenoid frame (ground) (Fig. 33). The resistance of the pull coil should be less than 1 ohm (but not zero).
3. Using a digital multimeter, touch one test lead to the hold coil terminal and the other test lead to the fuel stop solenoid frame (ground) (Fig. 33). The resistance of the hold coil should be approximately 15 ohms.
4. Connect solenoid to the wiring harness.

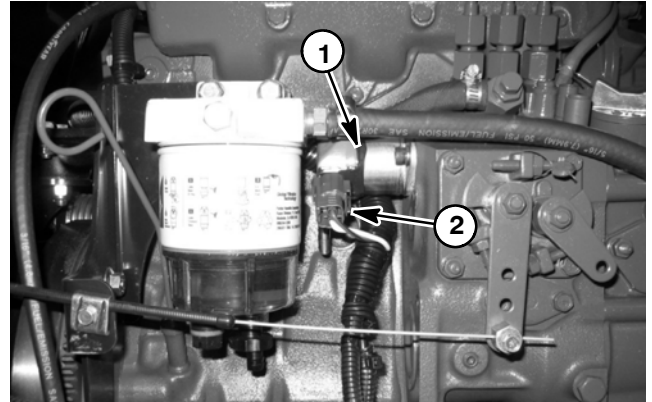

Figure 32

1. Fuel stop solenoid
2. Harness connector

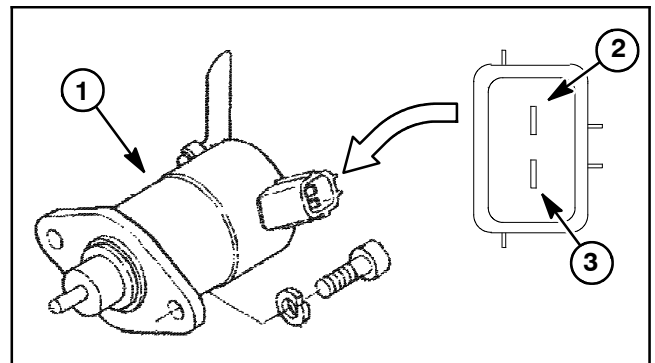

Figure 33

1. Fuel stop solenoid
2. Pull coil terminal
3. Hold coil terminal

## Glow Controller

The controller is located under the right, lower corner of the instrument panel.

**NOTE:** Refer to Electrical Diagrams - Chapter 8 when troubleshooting the glow controller.

### Controller Operation

1. When the ignition switch is placed in the RUN position, the controller energizes the glow plugs and lights up the glow lamp for 10 seconds.
2. When the ignition switch is held in the START position, the glow plugs will energize while the switch is held in START and the glow lamp will **not** light.
3. When the ignition switch is released from START to RUN, the glow plugs will de-energize and the glow lamp will remain off.

### Controller Checks

1. Make sure there is power from the battery.
2. Disconnect electrical connector to the fuel stop solenoid to prevent the engine from starting.
3. Place ignition switch in the RUN position. Verify the following while in the RUN position:
  - A. Glow indicator lamp is on.
  - B. Glow relay is energized.
  - C. Glow plugs are energized.
  - D. Glow indicator lamp goes out and glow plugs de-energize after 10 seconds.
4. Place ignition switch in the START position. Verify the following while in the START position:
  - A. Glow indicator lamp is out.
  - B. Glow relay is energized.
  - C. Glow plugs are energized.
  - D. Power exists at terminal 1 of the glow controller.

**NOTE:** If there is no power to terminal 1 of the glow controller, verify continuity of the circuitry from the ignition switch to the controller and perform Step 4 again (see Electrical Diagrams - Chapter 8).

5. If any of the conditions in Step 3 are not met or power to terminal 1 exists and any of the other conditions in Step 4 are not met:

- A. Verify continuity of the circuitry from the battery to the glow relay and glow plugs (see Electrical Diagrams - Chapter 8).
- B. Verify continuity of the circuitry from the battery to ignition switch, glow controller, glow lamp, glow relay, and ground (see Electrical Diagrams - Chapter 8).
- C. Replace parts as necessary.

6. Connect electrical connector to the fuel stop solenoid.

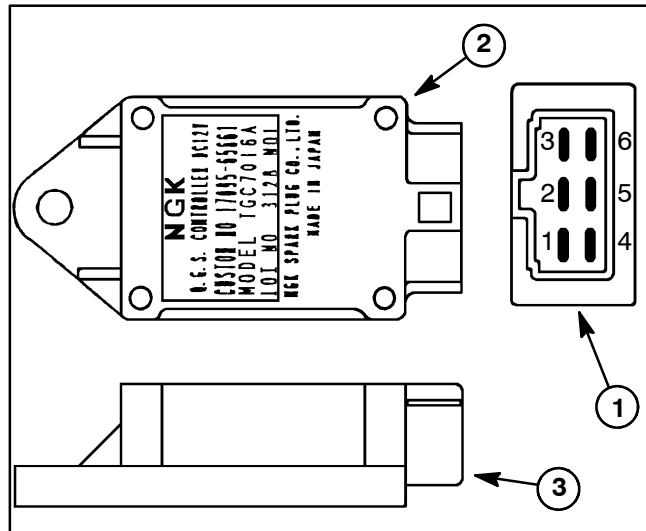

Figure 34

1. Glow controller end view
2. Top view
3. Side view

## Standard Control Module

Groundsmaster 3500- D machines with Serial Numbers above 240000000 are equipped with a Standard Control Module to monitor and control electrical components required for safe operation. This Module is attached to the back of the instrument panel.

Inputs from the neutral, parking brake, PTO, ignition, and high temperature switches are monitored by the Module. Output to the PTO (deck drive solenoid), engine starter motor, fuel pump, and engine run solenoid are controlled based on the inputs received by the Module.

The Standard Control Module does not connect to an external computer or hand held device, can not be re-programmed, and does not record intermittent fault data.

The Standard Control Module can be used to check operation of machine switches by monitoring the LED of the module. If a Module LED does not illuminate (e.g. the in seat input LED does not illuminate with the seat occupied and the ignition switch in the run position), testing of the switch and circuit wiring would be required.

Refer to the Traction Unit Operator's Manual for additional Standard Control Module information.

### Control Module Inputs (Fig. 36)

The Power input LED should be illuminated when the ignition key switch is in the RUN or START position.

The Start input LED should be illuminated when the ignition key switch is in the START position.

The Neutral input LED should be illuminated when the traction pedal is in the neutral position.

The Parking Brake Off input LED should be illuminated when the parking brake is not engaged.

The PTO Switch input LED should be illuminated when the PTO switch is engaged.

The In Seat input LED should be illuminated when the operator is sitting in the seat.

The Over Temperature Shutdown input LED should be illuminated when excessive engine coolant temperature causes the high temperature shutdown switch to close.

The Backlap input LED is not used on the Groundsmaster 3500- D.

### Control Module Outputs (Fig. 36)

The Start output LED should be illuminated when the ignition key switch is in the START position with the traction pedal in neutral, the PTO switch off and either the seat occupied or parking brake engaged.

The Run output LED should be illuminated when the ignition key switch is in the ON position and inputs from the neutral, parking brake, PTO, seat and over temperature switches indicate safe engine operation (e.g. seat occupied and parking brake disengaged when traction pedal is depressed).

The PTO output LED should be illuminated when the ignition key switch is in the ON position and the PTO switch is pulled out. Note: If Module Over Temperature Warning input LED is illuminated, PTO output LED will not be illuminated and PTO will not be engaged regardless of PTO switch position.

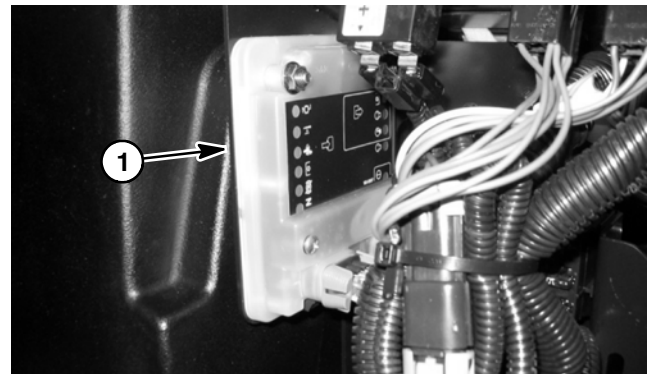

Figure 35

1. Standard Control Module

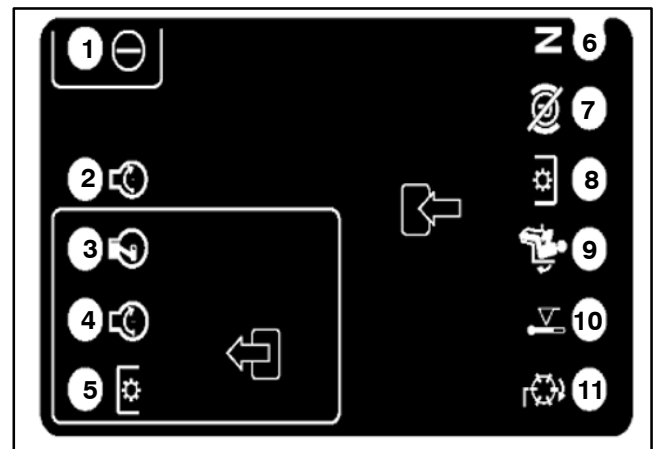

Figure 36

- |                          |                              |
|--------------------------|------------------------------|
| 1. Power input LED       | 6. Neutral input LED         |
| 2. Start input LED       | 7. Park brake off input LED  |
| 3. Engine run output LED | 8. PTO switch input LED      |
| 4. Start output LED      | 9. In seat input LED         |
| 5. PTO output LED        | 10. High temp input LED      |
|                          | 11. Backlap input (not used) |

# Service and Repairs

**NOTE:** For more electrical component repair information, see the Kubota Workshop Manual, Diesel Engine, 05 Series.

---

## Battery Storage

If the machine will be stored for more than 30 days:

1. Remove the battery and charge it fully (see Battery Service).
2. Either store battery on a shelf or on the machine.
3. Leave cables disconnected if the battery is stored on the machine.

4. Store battery in a cool atmosphere to avoid quick deterioration of the battery charge.

5. To help prevent the battery from freezing, make sure it is fully charged (see Battery Service).

---

## Battery Care

1. Battery electrolyte level must be properly maintained. The top of the battery must be kept clean. If the machine is stored in a location where temperatures are extremely high, the battery will run down more rapidly than if the machine is stored in a location where temperatures are cool.

solution. Flush top surface with water after cleaning. Do not remove the fill cap while cleaning.

3. Battery cables must be tight on terminals to provide good electrical contact.



### WARNING

**Wear safety goggles and rubber gloves when working with electrolyte. Charge battery in a well ventilated place so gasses produced while charging can dissipate. Since the gases are explosive, keep open flames and electrical sparks away from the battery; do not smoke. Nausea may result if the gases are inhaled. Unplug charger from electrical outlet before connecting or disconnecting charger leads to or from battery posts.**

2. Keep top of battery clean by washing periodically with a brush dipped in ammonia or bicarbonate of soda



### WARNING

**Connecting cables to the wrong post could result in personal injury and/or damage to the electrical system.**

4. If corrosion occurs at terminals, disconnect cables. Always disconnect negative (-) cable first. Scrape clamps and terminals separately. Reconnect cables with positive (+) cable first. Coat terminals with petroleum jelly.

5. Check electrolyte level every 25 operating hours, and every 30 days if machine is in storage.

6. Maintain cell level with distilled or demineralized water. Do not fill cells above the fill line.

## Battery Service

The battery is the heart of the electrical system. With regular and proper service, battery life can be extended. Additionally, battery and electrical component failure can be prevented.

	<b>CAUTION</b>
<b>When working with batteries, use extreme caution to avoid splashing or spilling electrolyte. Electrolyte can destroy clothing and burn skin or eyes. Always wear safety goggles and a face shield when working with batteries.</b>	

### Electrolyte Specific Gravity

Fully charged: 1.265 corrected to 80°F (26.7°C)  
Discharged: less than 1.240

### Battery Specifications

BCI Group Size 55:  
585 CCA at 0° F (-17.8° C)  
Reserve Capacity of 95 minutes at 80°F (26.7°C)

### Dimensions (including terminal posts and caps)

Length 9.05 inches (22.99 cm)  
Width 6.03 inches (15.31 cm)  
Height 8.50 inches (21.58 cm)

### Removal (Fig. 37 and 38)

**IMPORTANT: Be careful not to damage terminal posts or cable connectors when removing the battery cables.**

1. Remove battery cover from the frame. Loosen battery retainer securing the back of the battery to the battery support.
2. Loosen nut on ground cable (-) first and remove cable from battery. This should prevent short circuiting the battery, other components, or the operators hands.
3. Loosen nut on positive cable (+) and remove cable from battery.
4. Make sure battery vent caps are on tightly.
5. Remove battery from the battery compartment to a service area to allow better access for service.

### Inspection, Maintenance, and Testing

1. Perform the following inspections and maintenance:
  - A. Check for cracks. Replace battery if cracked or leaking.
  - B. Check battery terminal posts for corrosion. Use wire brush to clean corrosion from posts.

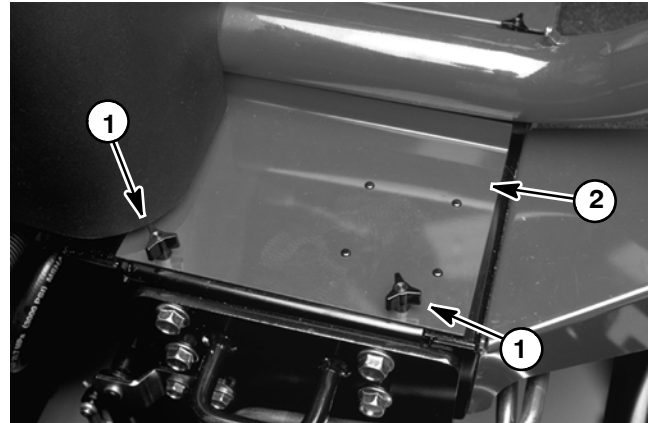

Figure 37

1. Knobs
2. Battery cover



Figure 38

1. Ground cable
2. Positive cable

**IMPORTANT: Before cleaning the battery, tape or block vent holes to the filler caps and make sure the caps are on tightly.**

C. Check for signs of wetness or leakage on the top of the battery which might indicate a loose or missing filler cap, overcharging, loose terminal post, or over-filling. Also, check battery case for dirt and oil. Clean the battery with a solution of baking soda and water, then rinse it with clean water.

D. Check that the cover seal is not broken away. Replace the battery if the seal is broken or leaking.

E. Check the electrolyte level in each cell. If the level is below the tops of the plates in any cell, fill all cells with **distilled** water between the minimum and maximum fill lines. Charge at 15 to 25 amps for 15 minutes to allow sufficient mixing of the electrolyte.

2. Conduct a hydrometer test of the battery electrolyte.

**IMPORTANT: Make sure the area around the cells is clean before opening the battery caps.**

A. Measure the specific gravity of each cell with a hydrometer. Draw electrolyte in and out of the hydrometer barrel prior to taking a reading to warm-up the hydrometer. At the same time, take the temperature of the cell.

B. Temperature correct each cell reading. For each 10°F (5.5°C) above 80°F (26.7°C) add 0.004 to the specific gravity reading. For each 10°F (5.5°C) below 80°F (26.7°C) subtract 0.004 from the specific gravity reading.

Example: Cell Temperature	100°F
Cell Gravity	1.245
100°F minus 80°F equals 20°F	
(37.7°C minus 26.7°C equals 11.0°C)	
20°F multiply by 0.004/10°F equals 0.008	
(11°C multiply by 0.004/5.5°C equals 0.008)	
ADD (conversion above)	<u>0.008</u>
Correction to 80°F (26.7°C)	1.253

C. If the difference between the highest and lowest cell specific gravity is 0.050 or greater or the lowest cell specific gravity is less than 1.225, charge the battery. Charge at the recommended rate and time given in **Charging** or until all cells specific gravity is 1.225 or greater with the difference in specific gravity between the highest and lowest cell less than 0.050. If these charging conditions can not be met, replace the battery.

3. Perform a high-discharge test with an adjustable load tester.

This is one of the most reliable means of testing a battery as it simulates the cold-cranking test. A commercial battery load tester is **required** to perform this test.



A. Check the voltage across the battery terminals prior to testing the battery. If the voltage is less than 12.4 VDC, recharge the battery.

B. If the battery has been charged, apply a 150 amp load for 15 seconds to remove the surface charge. Use a battery load tester following the manufacturer's instructions.

C. Make sure battery terminals are free of corrosion.

D. Measure the temperature of the center cell.

E. Connect a battery load tester to the battery terminals **following the manufacturer's instructions**. Connect a digital multimeter to the battery terminals.

F. Apply a test load of one half the Cranking Performance (see Battery Specifications) rating of the battery for 15 seconds.

G. Take a voltage reading at 15 seconds, then remove the load.

H. Using the table below, determine the minimum voltage for the cell temperature reading.

Minimum Voltage	Battery Electrolyte Temperature	
	9.6	70°F (and up)
9.5	60°F	15.6°C
9.4	50°F	10.0°C
9.3	40°F	4.4°C
9.1	30°F	-1.1°C
8.9	20°F	-6.7°C
8.7	10°F	-12.2°C
8.5	0°F	-17.8°C

I. If the test voltage is below the minimum, replace the battery. If the test voltage is at or above the minimum, return the battery to service.

**Installation**

**IMPORTANT: To prevent possible electrical problems, install only a fully charged battery.**

1. Make sure ignition and all accessories are **off**.
2. Make sure battery compartment is clean and repainted if necessary.
3. Make sure all battery cables, battery retainer and electrical connections are in good condition.
4. Place battery in its compartment. Make sure battery is level and flat. Connect positive cable connector onto positive battery post. Tighten cap screw and lock nut with two wrenches.

**IMPORTANT: The nut and flat washer must be on top of the battery retainer during installation to prevent the cap screw from hitting hydraulic hard lines when the sidewinder is shifted.**

5. Secure battery retainer. Do not overtighten to prevent cracking or distorting the battery case.

6. Apply a light coat of grease on all battery posts and cable connectors to reduce corrosion after connections are made.

7. Connect a digital multimeter (set to amps) between the negative battery post and the negative (ground) cable connector. The reading should be less than 0.1 amp. If the reading is 0.1 amp or more, the unit's electrical system should be tested and repaired.

8. Connect negative (ground) cable connector to the negative battery post. Tighten cap screw and lock nut with two wrenches.

### Charging

To minimize possible damage to the battery and allow the battery to be fully charged, the slow charging method is presented here. This charging method can be accomplished with a constant current battery charger which is available in most shops.

	<b>CAUTION</b>
<b>Follow the manufacturer's instructions when using a battery charger.</b>	

**NOTE:** Using specific gravity of the battery cells is the most accurate method of determining battery condition.

1. Determine the battery charge level from either its specific gravity or open circuit voltage.

Battery Charge Level	Specific Gravity	Open Circuit Voltage
100%	1.265	12.68
75%	1.225	12.45
50%	1.190	12.24
25%	1.155	12.06
0%	1.120	11.89

2. Determine the charging time and rate **using the manufacturer's battery charger instructions** or the following table:

Battery Reserve Capacity (Minutes)	Battery Charge Level (Percent of Fully Charged)			
	75%	50%	25%	0%
80 or less	3.8 hrs @ 3 amps	7.5 hrs @ 3 amps	11.3 hrs @ 3 amps	15 hrs @ 3 amps
81 to 125	5.3 hrs @ 4 amps	10.5 hrs @ 4 amps	15.8 hrs @ 4 amps	21 hrs @ 4 amps
126 to 170	5.5 hrs @ 5 amps	11 hrs @ 5 amps	16.5 hrs @ 5 amps	22 hrs @ 5 amps
171 to 250	5.8 hrs @ 6 amps	11.5 hrs @ 6 amps	17.3 hrs @ 6 amps	23 hrs @ 6 amps
above 250	6 hrs @ 10 amps	12 hrs @ 10 amps	18 hrs @ 10 amps	24 hrs @ 10 amps

	<b>CAUTION</b>
<b>Do not charge a frozen battery because it can explode and cause injury. Let the battery warm to 60°F (15.5° C) before connecting to a charger.</b>	
<b>Charge the battery in a well-ventilated place to dissipate gases produced from charging. These gases are explosive; keep open flame and electrical spark away from the battery. Do not smoke. Nausea may result if the gases are inhaled. Unplug the charger from the electrical outlet before connecting or disconnecting the charger leads from the battery posts.</b>	

3. **Following the manufacturer's instructions**, connect the charger cables to the battery. Make sure a good connection is made.

4. Charge the battery **following the manufacturer's instructions**.

5. Occasionally check the temperature of the battery electrolyte. If the temperature exceeds 125°F (51.6°C) or the electrolyte is violently gassing or spewing, the charging rate must be lowered or temporarily stopped.

6. Three hours prior to the end of the charging, measure the specific gravity of a battery cell once per hour. The battery is fully charged when the cells are gassing freely at a low charging rate and there is less than a 0.003 change in specific gravity for three consecutive readings.

## Solenoid Valve Coil

The solenoid valve coil on the hydraulic control manifold (Fig. 39) can be replaced without opening the hydraulic system.

### Removal

1. Park machine on a level surface, lower cutting decks, engage parking brake, stop engine and remove key from the ignition switch.
2. Disconnect the wire harness electrical connector from the solenoid valve coil.
3. Remove the nut from the spool assembly.
4. Slide the coil assembly from the solenoid valve stem. Discard the coil.
5. Clean any corrosion or dirt from the valve stem.

### Installation

1. Slide new coil assembly onto the solenoid valve stem.
2. Install the nut onto the spool assembly and torque nut 60 in- lb (6.8 N- m) (do not over tighten).
3. Connect the wire harness electrical connector to the solenoid valve coil.

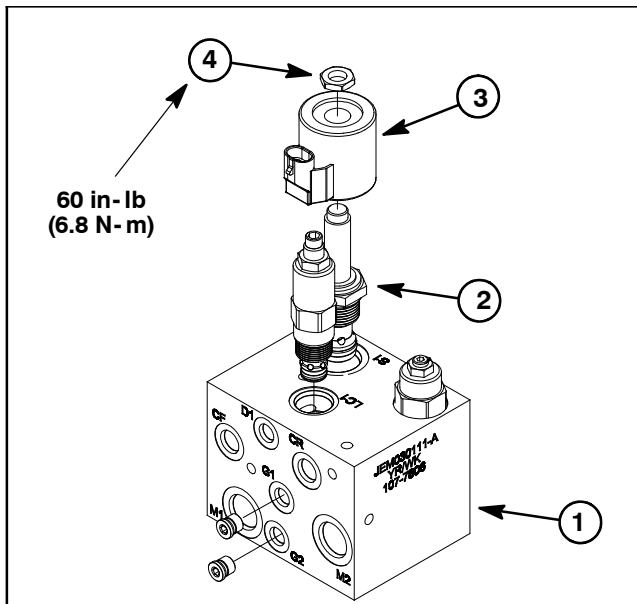

Figure 39

- |                        |                        |
|------------------------|------------------------|
| 1. Hydraulic manifold  | 3. Solenoid valve coil |
| 2. Solenoid valve (R1) | 4. Nut                 |





# Wheels, Brakes, and Chassis

## Table of Contents

SPECIFICATIONS .....	2	Deluxe Seat .....	9
SPECIAL TOOLS .....	2	Front Wheel and Brake .....	10
ADJUSTMENTS .....	3	Rear Fork and Wheel .....	12
Adjust Brake Lever .....	3	Brake Lever Linkages .....	14
Adjust Brakes .....	4	Steering Column .....	16
Adjust Front Lift Arms .....	5	Front Lift Arms .....	18
Adjust Front Lift Arm Carrier Stop Bracket Assembly .....	6	Rear Lift Arm .....	20
Adjust Rear Lift Arm .....	7	Sidewinder Carrier .....	22
SERVICE AND REPAIRS .....	8	Hood Removal .....	23
Standard Seat .....	8		

Wheels, Brakes,  
and Chassis

# Specifications

Item	Description
Tire pressure	14 to 18 PSI (0.97 to 1.24 bar)
Wheel lug nut torque	45 to 65 ft-lb (61 to 88 N-m)

## Special Tools

Order special tools from your Toro Distributor.

---

### Wheel Hub Puller

Part Number: **TOR4097**

The wheel hub puller allows safe removal of the wheel hub from the shaft of wheel motors.



Figure 1

# Adjustments

## Adjust Brake Lever

Brake lever adjustment should be checked every 200 hours.



### CAUTION

**Before and after adjusting the brakes, always check the brakes in a wide open area that is flat and free of other persons and obstructions.**

1. Park machine on a level surface, lower cutting units, stop engine, and remove key from the ignition switch.
2. Loosen set screw on the adjustment knob (Fig. 1).
3. Adjust travel of brake lever until a force of 30 to 40 lbs (133 to 178 N) is required to actuate lever:
  - A. Turn adjustment knob clockwise to increase force.
  - B. Turn adjustment knob counterclockwise to decrease force.
4. Tighten set screw after adjustment has been attained.

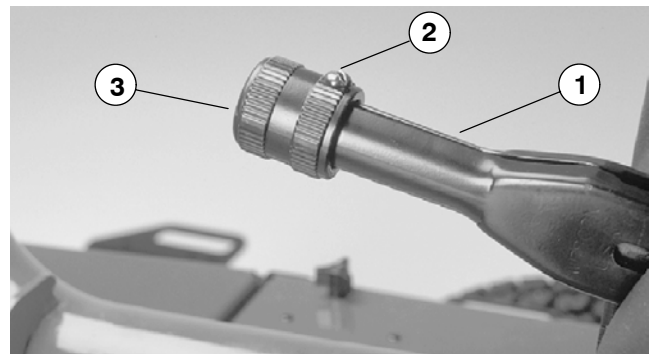

Figure 1

1. Brake lever
2. Set screw
3. Adjustment knob

## Adjust Brakes



### CAUTION

**Before and after adjusting the brakes, always check the brakes in a wide open area that is flat and free of other persons and obstructions.**

#### 1. Check brake adjustment as follows:

A. Park machine on a level surface, lower cutting units, stop engine, and remove key from the ignition switch.

B. Rotate by-pass valve on the piston pump 90 degrees to allow front wheels to turn freely (Fig. 2).



### CAUTION

**Before jacking up the machine, review and follow Jacking Instructions in Chapter 1 - Safety.**

C. Chock rear wheel. Jack up both front wheels and support the machine with hardwood blocks.

D. Apply the parking brake. The force to actuate the brake lever should be from 30 to 40 lbs (133 to 178 N).

E. With the parking brake applied, use a torque wrench on the wheel hub lock nut to identify the break away torque at each front wheel. The minimum break away torque with the parking applied should be 300 ft-lb (407 N-m).

#### 2. If adjustment is necessary, adjust brakes as follows:

A. Remove both front wheel assemblies from the machine (see Front Brake and Wheel Removal in the Service and Repairs section).

B. Adjust brakes by turning clevis to increase or decrease shoe pressure on the brake drum (Fig. 3). Make sure that brake shoes do not drag against drums with the parking brake lever released.

C. If brakes can not be adjusted properly, repair or replace brake components as necessary.

D. After adjustment is complete, install both front wheel assemblies to the machine (see Front Brake and Wheel Installation in the Service and Repairs section).

E. Lower front wheels to the ground.

F. Before starting engine, close by-pass valve on pump by rotating it 90 degrees (Fig. 2).

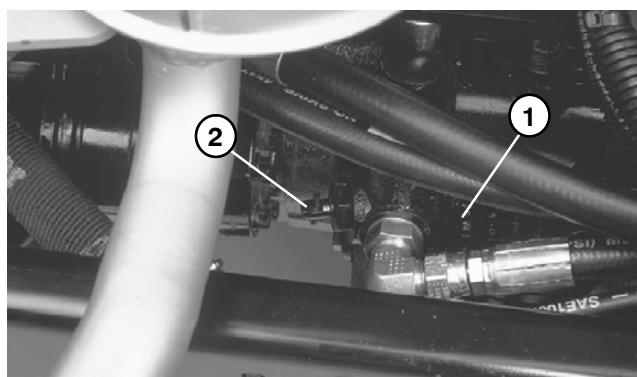

Figure 2

1. Piston pump

2. By-pass valve

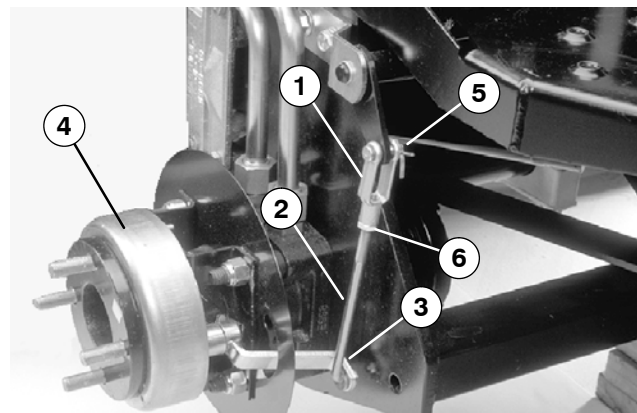

Figure 3

1. Clevis

2. Adjustment rod

3. Brake lever

4. Wheel hub

5. Cotter pin

6. Jam nut

## Adjust Front Lift Arms

1. Park machine on a level surface, fully raise cutting units, stop engine, engage parking brake, and remove key from the ignition switch.

**IMPORTANT: Keep front cutting units on the lift arms when performing this adjustment.**

2. Make sure clearance between each lift arm and floor plate bracket is from 0.18 to 0.32 inch (4.6 to 8.1 mm) (Fig. 4).

3. If the clearance is not in this range, attain proper clearance as follows:

A. Lower front lift arms, stop engine, engage parking brake, and remove key from the ignition switch. Back off stop bolts if reducing the clearance between the lift arm and the floor plate bracket (Fig. 5).

B. Adjust front hydraulic cylinder by backing off jam nut on the cylinder, removing the pin from the clevis, and rotating the clevis (Fig. 6).

C. Install pin to clevis. Fully raise front lift arms and check clearance. Repeat steps A and B if necessary.

D. Tighten jam nut on the hydraulic cylinder when clearance is correct.

**IMPORTANT: The lack of clearance at the front stops can damage the lift arms.**

4. With the front lift arms fully raised, make sure clearance between each lift arm and stop bolt is from 0.005 to 0.040 inch (0.13 to 1.02 mm). If the clearance is not in this range, adjust stop bolts as necessary (Fig 5).

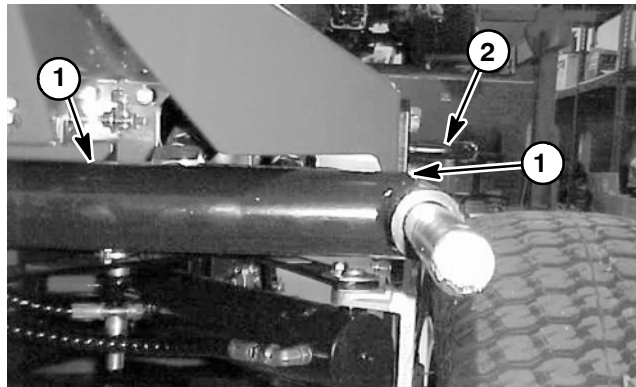

Figure 4

- 1. Lift arm
- 2. Floor plate bracket
- 3. Clearance

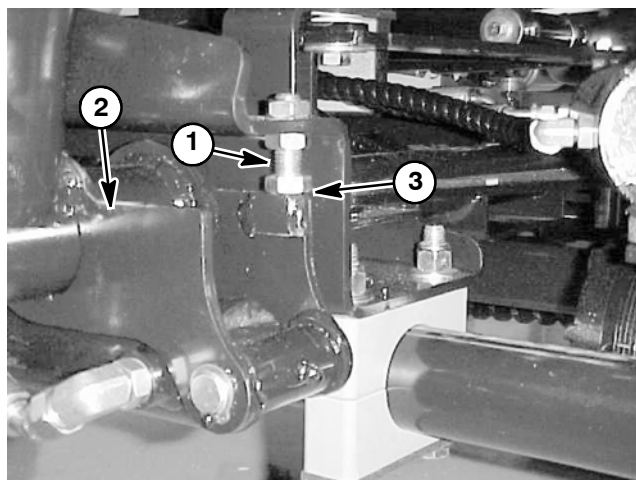

Figure 5

- 1. Stop bolt
- 2. Lift arm
- 3. Clearance

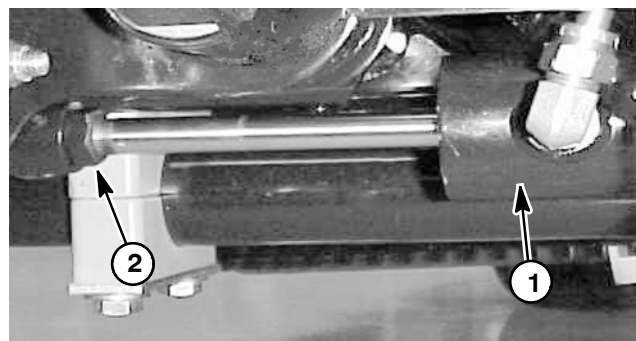

Figure 6

- 1. Hydraulic cylinder
- 2. Jam nut

## Adjust Front Lift Arm Carrier Stop Bracket Assembly

1. Park machine on a level surface, fully raise cutting units, stop engine, engage parking brake, and remove key from the ignition switch.

2. Make sure that pivot brackets (items 6 and 9) are not overtightened. They should pivot and return freely.

3. To allow horizontal movement of the actuators (items 2 and 8), loosen carriage screws and flange nuts that secure actuators to actuator mount brackets.

4. To allow vertical movement of the actuator mount brackets (item 3), loosen carriage screws and flange nuts that secure actuator mount brackets to lift arms.

5. Simultaneously move both actuators against back of the carrier stop bracket and pivot brackets. Secure actuators (items 2 and 8) to actuator mount brackets with carriage screws and flange nuts.

6. With pivot brackets tipped forward, slide actuator mount brackets down so that the actuators just contact the pivot brackets. Secure actuator mount brackets to lift arms with carriage screws and flange nuts.

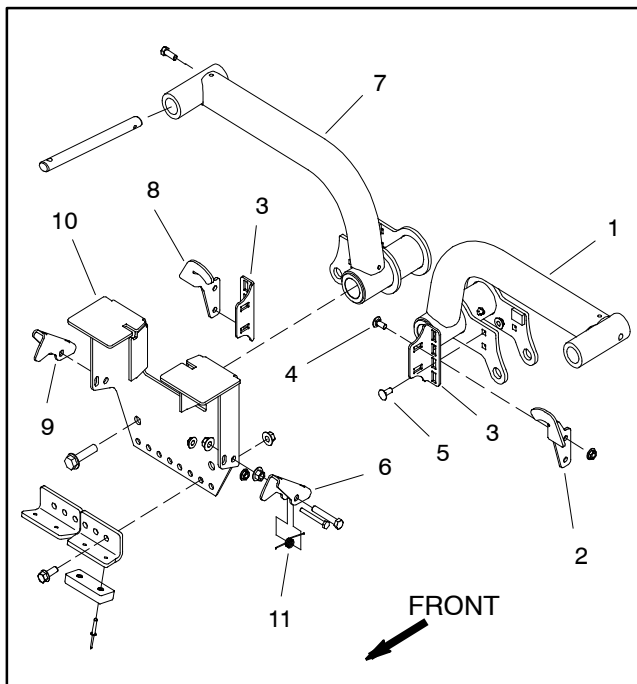

Figure 7

- |                           |                          |
|---------------------------|--------------------------|
| 1. LH lift arm            | 7. RH lift arm           |
| 2. LH actuator            | 8. RH actuator           |
| 3. Actuator mount bracket | 9. RH pivot bracket      |
| 4. Horizontal screw       | 10. Carrier stop bracket |
| 5. Vertical screw         | 11. Return spring        |
| 6. LH pivot bracket       |                          |

## Adjust Rear Lift Arm

1. Park machine on a level surface and engage parking brake.

**IMPORTANT:** This adjustment must be performed with the rear cutting unit attached to the rear lift arm.

2. Raise lift arms. Make sure clearance between wear strap on the top of the rear cutting unit wear bar and bumper strap is from 0.020 to 0.100 inch (0.51 to 2.54 mm) (Fig. 8).

3. If the clearance is not in this range, attain proper clearance by adjusting the rear hydraulic cylinder as follows (Fig. 9):

A. Lower cutting units, turn engine off, and remove key from the ignition switch.

B. Back off jam nut from the rear hydraulic cylinder clevis.

**IMPORTANT:** Use a protective covering around the hydraulic cylinder rod when rotating the rod to prevent damage to the rod.

C. Grasp cylinder rod near the jam nut and rotate the rod.

D. Raise cutting units and check clearance. Repeat steps A through C as necessary. Tighten jam nut on hydraulic cylinder rod when clearance is correct.

**NOTE:** If rear lift arm makes clunking noises during transport, the clearance can be reduced.

**IMPORTANT:** The lack of clearance at the rear wear bar can damage the rear lift arm.

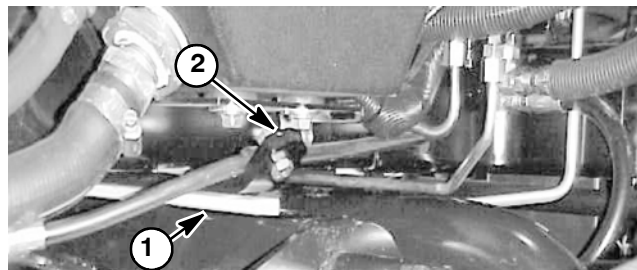

Figure 8

1. Wear bar

2. Bumper strap

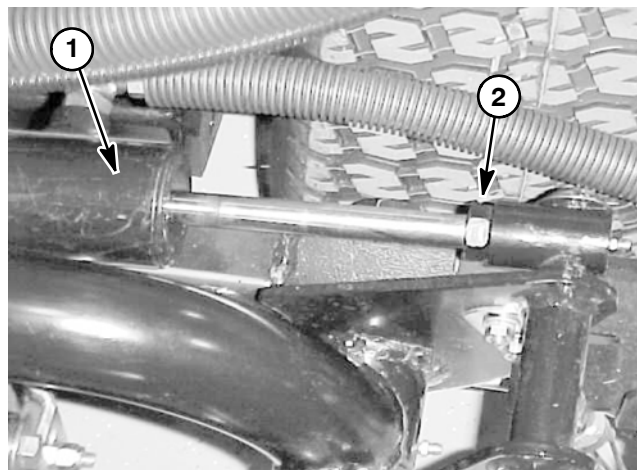

Figure 9

1. Rear hydraulic cylinder

2. Jam nut





## Deluxe Seat

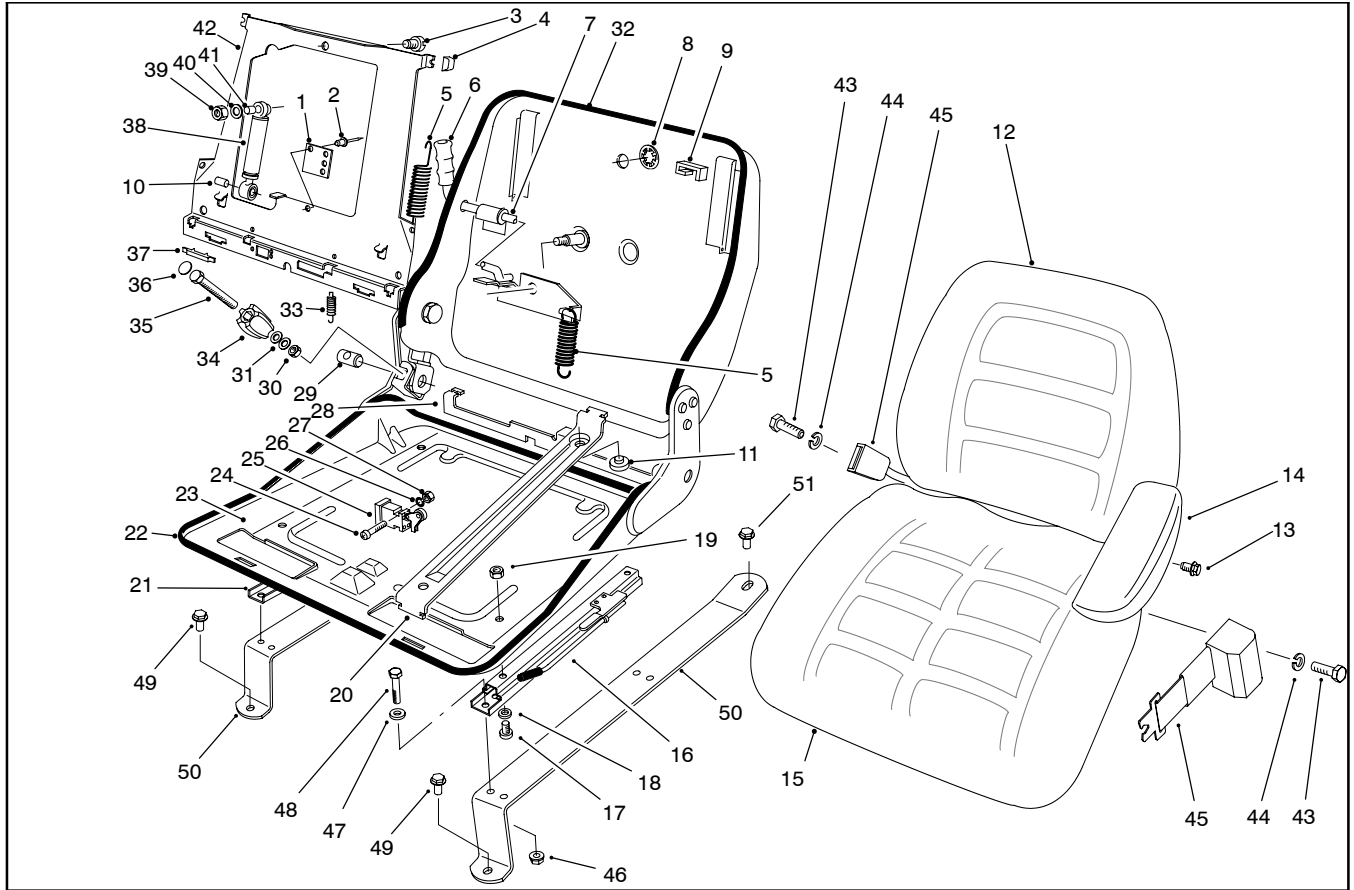

Figure 10

- |                                     |  |                                 |
|-------------------------------------|--|---------------------------------|
| 1. Plate                            | 18. Washer                                       | 35. Screw                       |
| 2. Rivet                            | 19. Nut  | 36. Cover                       |
| 3. Screw                            | 20. Swing arm assembly (incl. 28 & 42)           | 37. Clamp                       |
| 4. Wear parts kit (incl. 8 thru 11) | 21. Adjusting rail (RH)                          | 38. Shock absorber              |
| 5. Tension spring set               | 22. Bottom trim                                  | 39. Nut                         |
| 6. Handle grip                      | 23. Seat frame                                   | 40. Washer                      |
| 7. Adjusting lever                  | 24. Screw  | 41. Bushing kit (incl. 39 & 40) |
| 8. Cover                            | 25. Seat switch (incl. 24, 26, & 27)             | 42. Backrest plate              |
| 9. Bumper                           | 26. Spring washer                                | 43. Cap screw                   |
| 10. Bushing                         | 27. Nut  | 44. Lock washer                 |
| 11. Pad                             | 28. Back plate pivot                             | 45. Seat belt                   |
| 12. Backrest cushion                | 29. Threaded clevis                              | 46. Hex flange nut              |
| 13. Hex head machine screw          | 30. Nut  | 47. Flat washer                 |
| 14. Arm rests                       | 31. Washer                                       | 48. Cap screw                   |
| 15. Bottom cushion                  | 32. Backrest trim                                | 49. Hex flange head screw       |
| 16. Adjusting rail (LH)             | 33. Tension spring set                           | 50. Seat support strap          |
| 17. Screw                           | 34. Spindle adjuster (incl. 29 thru 31, 35 & 36) | 51. Hex flange head screw       |

### Removal

1. Park machine on a level surface, lower cutting units, stop engine, engage parking brake, and remove key from the ignition switch.
2. Remove four hex flange head screws securing the seat support straps to the frame.
3. Disconnect electrical connector from the seat switch. Separate seat from the frame.
4. Remove seat parts as necessary to make repairs using Figure 10 as a guide.

### Installation

1. Install any new seat parts using Figure 10 as a guide.
2. Position seat and support straps to the fuel tank and frame.
3. Attach electrical connector to the seat switch.
4. Secure seat support straps to the frame with four hex flange head screws.

## Front Wheel and Brake

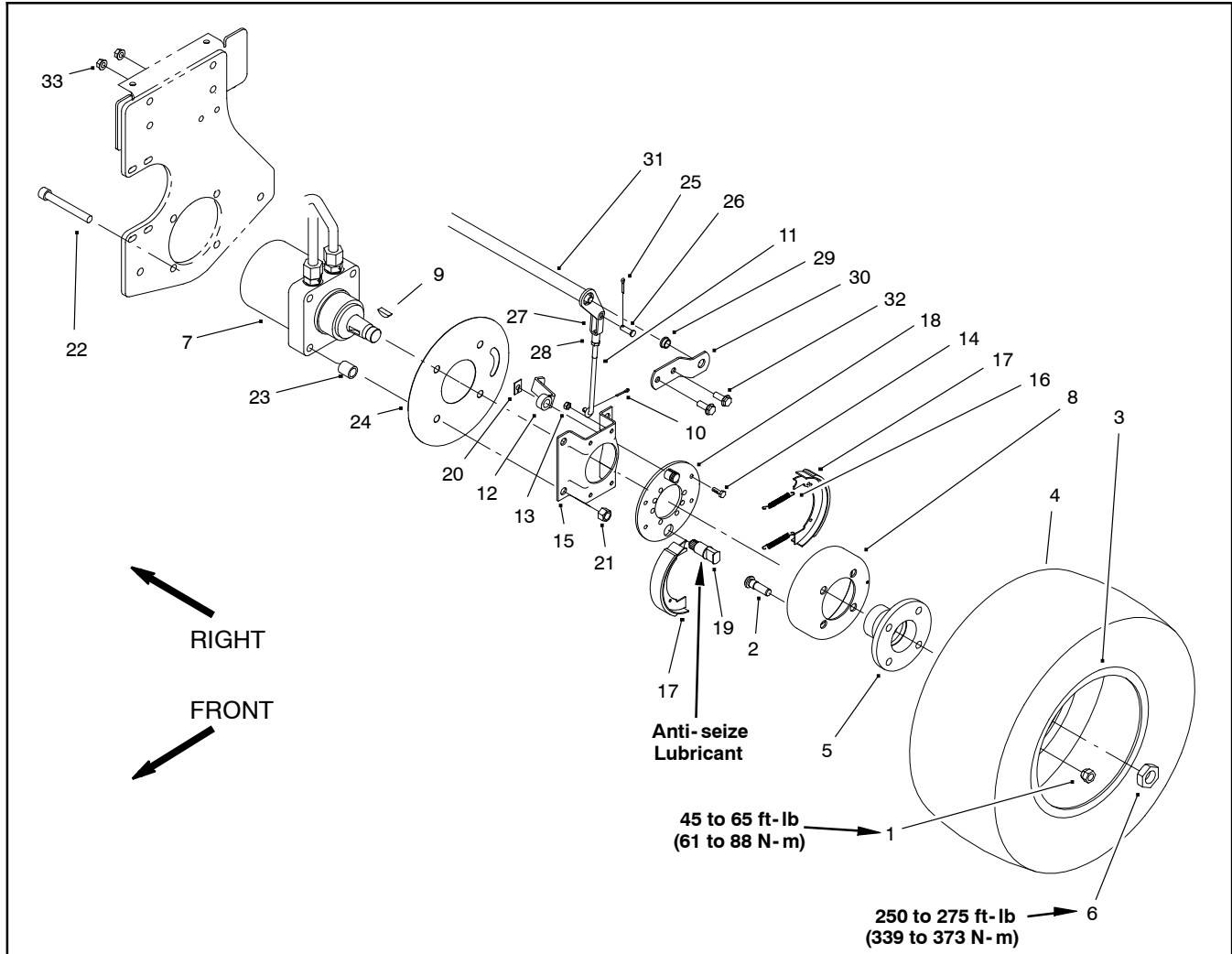

Figure 12

- |                          |                   |                           |
|--------------------------|-------------------|---------------------------|
| 1. Lug nut               | 12. Brake lever   | 23. Spacer                |
| 2. Drive stud            | 13. Lock nut      | 24. Wheel shield          |
| 3. Wheel rim             | 14. Cap screw     | 25. Cotter pin            |
| 4. Tire                  | 15. Brake bracket | 26. Clevis pin            |
| 5. Wheel hub             | 16. Return spring | 27. Clevis                |
| 6. Lock nut              | 17. Brake shoe    | 28. Jam nut               |
| 7. Hydraulic wheel motor | 18. Backing plate | 29. Flange bushing        |
| 8. Brake drum            | 19. Cam shaft     | 30. Brake pivot bracket   |
| 9. Woodruff key          | 20. Retainer clip | 31. Brake pivot shaft     |
| 10. Cotter pin           | 21. Lock nut      | 32. Hex flange head screw |
| 11. Adjustment rod       | 22. Cap screw     | 33. Hex flange nut        |

### Removal (Fig. 12)

1. Park machine on a level surface, lower cutting units, stop engine, engage parking brake, and remove key from the ignition switch.

2. Jack up front wheel and use wood blocks to keep the front tire off the floor.

3. Remove lug nuts from drive studs. Pull wheel from drive studs and wheel hub.

**NOTE:** The installation torque of the lock nut is from 250 to 275 ft-lb (339 to 373 N-m). Use impact wrench to loosen lock nut from the hydraulic motor shaft.

4. Loosen, but do not remove, lock nut from the hydraulic motor shaft. Release parking brake.



## WARNING

Before jacking up the machine, review and follow Jacking Instructions in Chapter 1 - Safety.

**IMPORTANT: DO NOT hit wheel hub, wheel hub puller or wheel motor with a hammer during wheel hub removal or installation. Hammering may cause damage to the wheel motor.**

5. Using hub puller (see Special Tools), loosen wheel hub from wheel motor.

6. Remove lock nut, hub, and brake drum from motor shaft. Locate and retrieve woodruff key.

7. Remove cotter pin from the adjustment rod. Separate adjustment rod from the brake lever.

**NOTE:** The brake lever, backing plate, retaining clip, return springs, brake shoes, and cam shaft can be removed as a complete brake assembly.

8. If it is desired to remove the brake assembly from the brake bracket, remove four cap screws and lock nuts securing the assembly to the bracket.

9. Disassemble brake assembly as follows (Fig. 13):

A. Remove return springs from the brake shoes. Remove brake shoes from the backing plate.

B. Matchmark brake cam and brake lever to assure proper alignment during reassembly. Remove retaining clip from the brake cam. Pull brake lever from the cam. Remove cam from backing plate.

10. The brake bracket and wheel shield can be removed as follows:

A. Remove lock nuts, spacers, and cap screws securing the brake bracket, wheel shield, and hydraulic motor to the frame.

B. Separate bracket and shield from the frame.

### Installation (Fig. 12)

1. Insert four cap screws through the frame, hydraulic motor, spacers, wheel shield, and brake bracket. Secure with lock nuts, but do not fully tighten.

2. Assemble brake assembly as follows (Fig. 13):

A. Secure backing plate to the brake bracket with four cap screws and lock washers.

B. Apply antiseize lubricant to cam shaft splines. Insert cam shaft through the backing plate.

C. Attach brake lever to the cam shaft. Make sure matchmarks are aligned properly. Secure lever to shaft with retaining clip.

D. Lubricate brake shoe pivot points with a light coating of grease.

E. Position both brake shoes on the backing plate so that the concave heels attach to the anchor pin.

F. Insert both return springs into the holes of both brake shoes. Make sure shoes fit snugly against the anchor pin and cam.

3. If the brake lever, backing plate, retaining clip, return springs, brake shoes, and cam shaft were removed as a complete brake assembly, secure backing plate to the brake bracket with four cap screws and lock washers. Tighten fasteners.

4. Attach adjustment rod to the brake lever. Secure adjustment rod with cotter pin.

5. Thoroughly clean wheel motor shaft and wheel hub taper.

6. Install woodruff key to the slot on the hydraulic motor shaft. Slide wheel hub and brake drum assembly onto the shaft.

7. Secure wheel hub and brake drum to the hydraulic motor shaft with lock nut.

**NOTE:** For proper brake operation, the brake shoes and backing plate must be concentrically aligned with the brake drum.

8. To align brake shoes and drum, apply parking brake. Then tighten four socket head screws and lock nuts that secure the brake bracket and wheel motor to the frame.

9. Place wheel onto drive studs and wheel hub. Secure wheel with lug nuts on drive studs.

10. Lower wheel to ground. Torque lug nuts from 45 to 65 ft-lb (61 to 88 N-m) in a criss-cross pattern. Torque lock nut from 250 to 275 ft-lb (339 to 373 kg-m).

11. Check and adjust brakes (see Adjust Brakes).

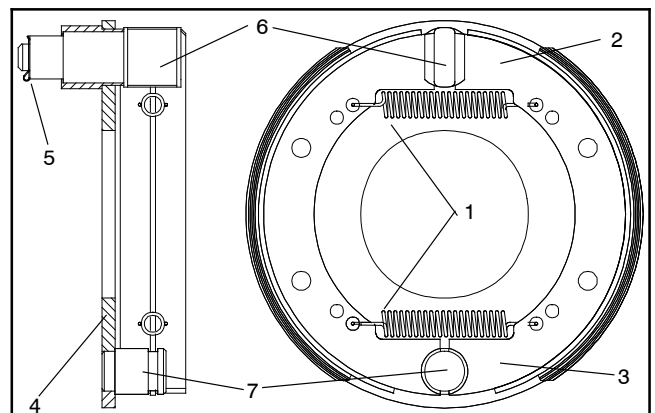

Figure 13

- |                          |                   |
|--------------------------|-------------------|
| 1. Return spring         | 5. Retaining clip |
| 2. Brake shoe (toe end)  | 6. Cam shaft      |
| 3. Brake shoe (heel end) | 7. Anchor pin     |
| 4. Backing plate         |                   |

### Burnish Brake Pads

After brake pad replacement, burnish (brake-in) the brakes before use.

1. Bring the machine to full speed and apply the brakes to rapidly stop the machine without skidding or locking up the wheels.

2. Repeat this procedure 10 times. To avoid overheating the brakes, wait 1 minute between each stop.

# Rear Fork and Wheel

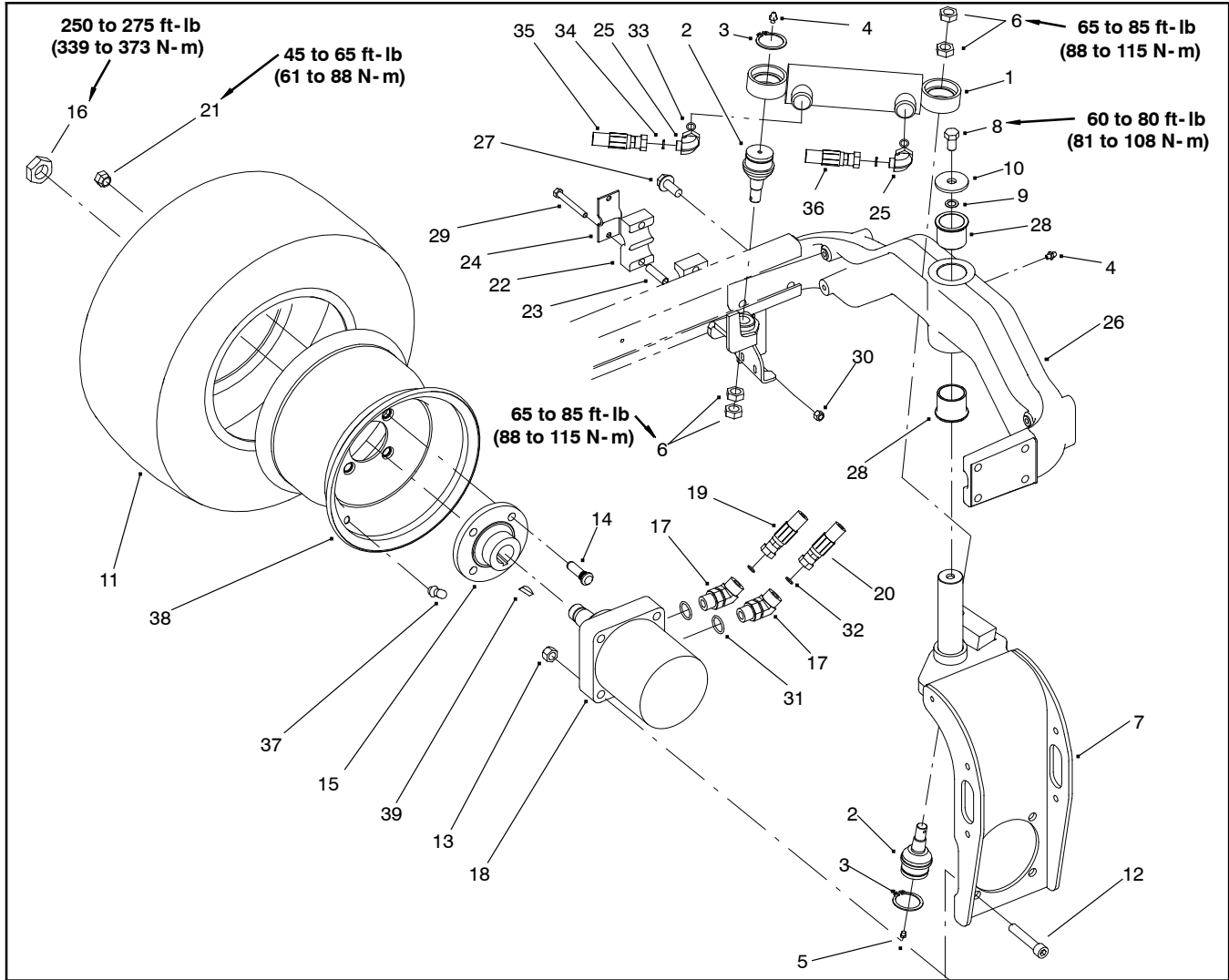

Figure 14

- |                                |                           |                           |
|--------------------------------|---------------------------|---------------------------|
| 1. Hydraulic steering cylinder | 14. Drive stud            | 27. Hex flange head screw |
| 2. Ball joint                  | 15. Wheel hub             | 28. Bushing               |
| 3. External retaining ring     | 16. Lock nut              | 29. Cap screw             |
| 4. Grease fitting              | 17. 45° hydraulic fitting | 30. Lock nut              |
| 5. Grease fitting plug         | 18. Hydraulic motor       | 31. O-ring                |
| 6. Jam nut                     | 19. Hydraulic hose        | 32. O-ring                |
| 7. Rear fork                   | 20. Hydraulic hose        | 33. O-ring                |
| 8. Cap screw                   | 21. Lug nut               | 34. O-ring                |
| 9. Lock washer                 | 22. Clamp                 | 35. Hose assembly         |
| 10. Thrust washer              | 23. Spacer                | 36. Hose assembly         |
| 11. Tire                       | 24. Clamp                 | 37. Valve stem            |
| 12. Hex socket head screw      | 25. Hydraulic fitting     | 38. Wheel rim             |
| 13. Lock nut                   | 26. Rear casting          | 39. Woodruff key          |

## Removal

1. Park machine on a level surface, lower cutting units, stop engine, engage parking brake, and remove key from the ignition switch.
2. Remove hood from the machine (see Hood Removal).



3. Jack up rear wheel enough to allow the removal of the rear fork.
4. Remove lug nuts from drive studs. Remove tire and wheel rim from wheel hub.
5. Separate hydraulic cylinder from the rear fork as follows:
  - A. Remove both jam nuts securing the ball joint to the rear fork.
  - B. Separate ball joint from the rear fork.
  - C. Swing cylinder clear of the rear fork.
6. Remove four lock nuts and hex socket head screws securing the hydraulic motor to the rear fork. Remove motor from the fork and position it away from the fork.



7. Remove cap screw, thrust washer, and lock washer from the rear fork shaft.
8. Lower rear fork from machine.
9. Check bushings for wear and damage. Replace if necessary.

## Installation

1. Position rear fork through the frame.
2. Install lock washer, thrust washer, and cap screw to the rear fork shaft. Torque cap screw from 60 to 80 ft-lb (81 to 108 N-m). Make sure fork turns freely.
3. Install hydraulic motor to the rear fork. Secure motor to the fork with four hex socket head screws and lock nuts.
4. Secure hydraulic cylinder to the rear fork as follows:
  - A. Swing cylinder to the rear fork.
  - B. Install ball joint to rear fork.
  - C. Secure ball joint to the rear fork with both jam nuts. Tighten the first jam nut from 65 to 85 ft-lb (88 to 115 N-m), then tighten the second jam nut to the same specification.
5. Secure wheel rim to the wheel hub with four lug nuts. Torque nuts from 45 to 65 ft-lb (61 to 88 N-m).
6. Lower rear wheel to the ground.

## Brake Lever Linkages

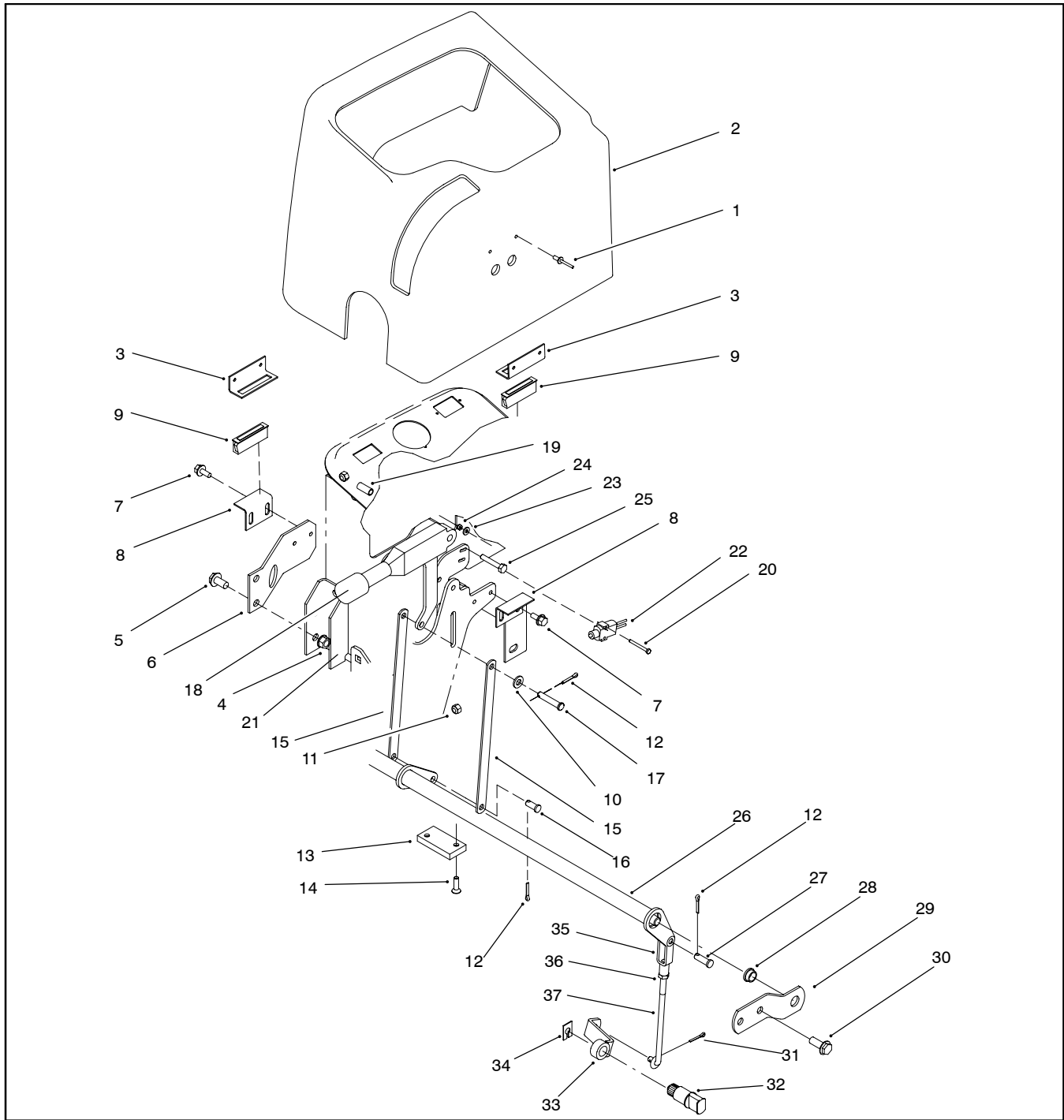

Figure 14

- |                          |                                |                           |
|--------------------------|--------------------------------|---------------------------|
| 1. Pop rivet             | 14. Hex socket flat head screw | 26. Brake pivot shaft     |
| 2. Control panel cover   | 15. Parking brake link         | 27. Clevis pin            |
| 3. Cover bracket         | 16. Clevis pin                 | 28. Flange bushing        |
| 4. Flange nut            | 17. Clevis pin                 | 29. Brake pivot bracket   |
| 5. Hex flange head screw | 18. Lever assembly             | 30. Hex flange head screw |
| 6. Magnet support        | 19. Parking brake spacer       | 31. Cotter pin            |
| 7. Hex washer head screw | 20. Slotted hex head screw     | 32. Brake cam shaft       |
| 8. Strike bracket        | 21. Frame                      | 33. Brake lever           |
| 9. Magnetic catch        | 22. Switch                     | 34. Retainer clip         |
| 10. Flat washer          | 23. Flat washer                | 35. Adjustable clevis     |
| 11. Lock nut             | 24. Lock nut                   | 36. Jam nut               |
| 12. Cotter pin           | 25. Cap screw                  | 37. Adjustment rod        |
| 13. Bumper pad           |                                |                           |

1. Park machine on a level surface, lower cutting units, stop engine, engage parking brake, and remove key from the ignition switch.

2. Remove control panel cover from the machine.

**IMPORTANT: When removing the adjustable clevis from either the brake pivot shaft or adjustment rod or the brake lever from the cam shaft on the brake assembly, make sure to matchmark both parts. Marking both parts will make reassembly and brake adjustment easier.**

3. Remove and replace parts as necessary to repair brake linkages.

4. Install control panel cover to the machine.

**IMPORTANT: Always check and adjust brakes anytime brake linkages are disassembled or repaired.**

5. Adjust brake linkages (see Adjust Brakes).

# Steering Column

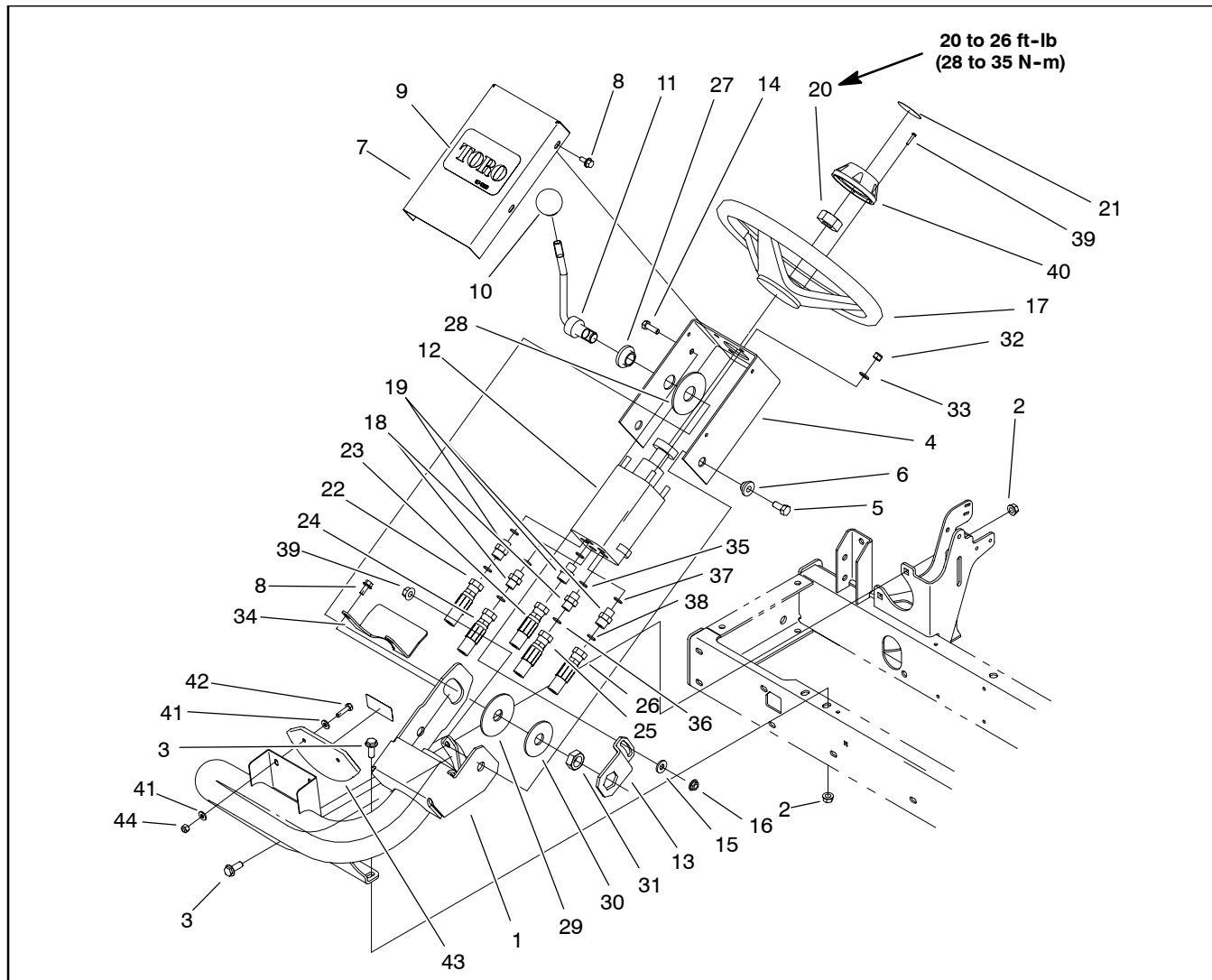

Figure 15

- |                                   |                        |                        |
|-----------------------------------|------------------------|------------------------|
| 1. Steering arm                   | 16. Flange nut         | 31. Jam nut            |
| 2. Flange nut                     | 17. Steering wheel     | 32. Lock nut           |
| 3. Flange head screw              | 18. Hydraulic fitting  | 33. Flat washer        |
| 4. Steering control valve bracket | 19. Hydraulic fitting  | 34. Steering shield    |
| 5. Cap screw                      | 20. Steering wheel nut | 35. O-ring             |
| 6. Pivot hub                      | 21. Toro decal         | 36. O-ring             |
| 7. Steering cover                 | 22. Hydraulic hose     | 37. O-ring             |
| 8. Cap screw                      | 23. Hydraulic hose     | 38. O-ring             |
| 9. Toro decal                     | 24. Hydraulic hose     | 39. Philips head screw |
| 10. Ball knob                     | 25. Hydraulic hose     | 40. Steering wheel cap |
| 11. Steering tilt lever           | 26. Hydraulic hose     | 41. Flat washer        |
| 12. Steering control valve        | 27. Tilt steering boss | 42. Cap screw          |
| 13. Tilt bracket                  | 28. Friction disc      | 43. Slope indicator    |
| 14. Cap screw                     | 29. Friction disc      | 44. Lock nut           |
| 15. Flat washer                   | 30. Flat washer        |                        |



## Disassembly

1. Park machine on a level surface, lower cutting units, stop engine, engage parking brake, and remove key from the ignition switch.
2. Remove philips head screws and steering wheel cap from the steering wheel.
3. Remove steering wheel nut from the steering control valve. Pull steering wheel from the control valve.
4. Remove steering cover from the steering control valve bracket.
5. Remove four lock nuts and flat washers securing the steering control valve to the steering control valve bracket.
6. Remove both hex flange nuts, cap screws, and pivot hubs securing the steering control valve bracket to the steering arm. Slide bracket from the steering control valve and steering arm.
7. Remove and replace parts as necessary to repair steering column using Figure 15 as a guide.

## Assembly

1. Make sure lever and friction discs are properly assembled to the steering control valve bracket using Figures 15 and 16 as a guide.
2. Position steering control bracket to the steering control valve and steering arm. Secure bracket to the steering arm with pivot hubs, cap screws, and hex flange nuts.
3. Secure steering control valve bracket to the steering control valve studs with four flat washers and lock nuts.
4. Secure steering cover to the steering control valve bracket with cap screws.
5. Install steering wheel to the steering control valve. Torque steering wheel nut from 20 to 26 ft-lb (28 to 35 N-m).
6. Secure steering wheel cap to the steering wheel with six philips head screws.

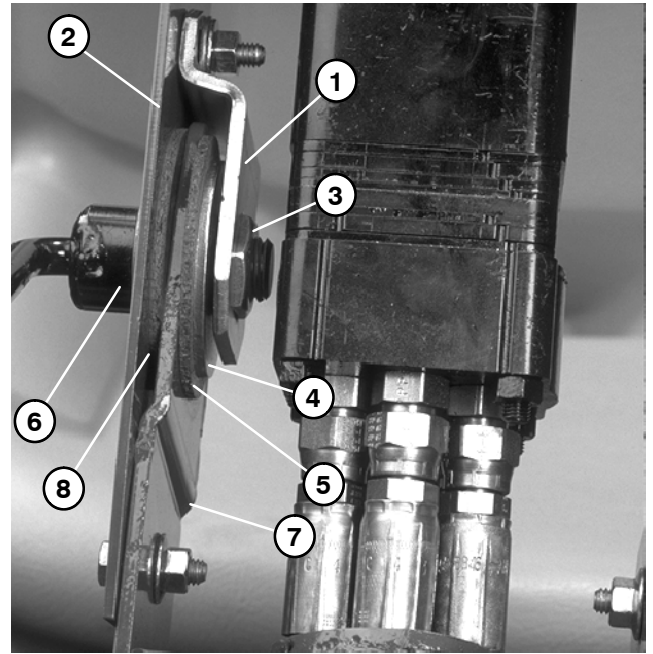

Figure 16

- |                           |                        |
|---------------------------|------------------------|
| 1. Tilt bracket           | 5. Friction disc       |
| 2. Steering valve bracket | 6. Tilt steering lever |
| 3. Jam nut                | 7. Steering arm        |
| 4. Flat washer            | 8. Friction disc       |

# Front Lift Arms

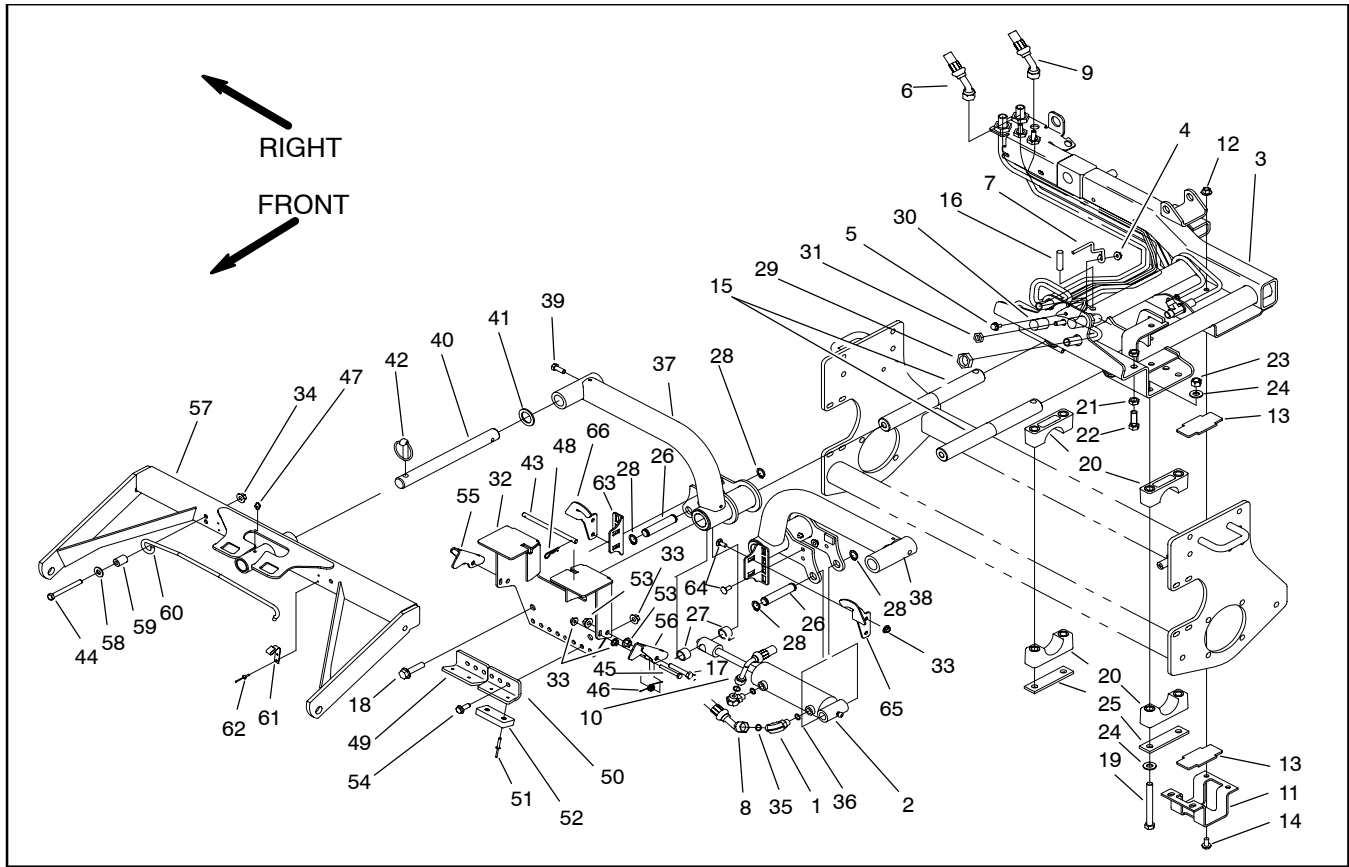

Figure 17

- |                                |                             |                         |
|--------------------------------|-----------------------------|-------------------------|
| 1. 90° hydraulic fitting       | 23. Lock nut                | 45. Cap screw           |
| 2. Hydraulic cylinder          | 24. Thrust washer           | 46. Torsion spring      |
| 3. Sidewinder carrier assembly | 25. Slide support bar       | 47. Grease fitting      |
| 4. Flange nut                  | 26. Pin                     | 48. Hair pin            |
| 5. Flange head screw           | 27. Spacer                  | 49. RH deck stop        |
| 6. Hydraulic hose              | 28. External retaining ring | 50. LH deck stop        |
| 7. Centering wire              | 29. Bulkhead nut            | 51. Rivet               |
| 8. Hydraulic hose              | 30. Hydraulic tube          | 52. Rubber bumper       |
| 9. Hydraulic hose              | 31. Bulkhead nut            | 53. Flange nut          |
| 10. Hydraulic hose             | 32. Carrier stop bracket    | 54. Flange head screw   |
| 11. Slide bracket              | 33. Nut                     | 55. RH pivot bracket    |
| 12. Flange nut                 | 34. Flange nut              | 56. LH pivot bracket    |
| 13. Plastic slide              | 35. O-ring                  | 57. Front carrier frame |
| 14. Flange head screw          | 36. O-ring                  | 58. Flat washer         |
| 15. Lift arm pivot shaft       | 37. RH liftarm              | 59. Latch tube          |
| 16. Roll pin                   | 38. LH liftarm              | 60. Latch rod           |
| 17. Cap screw                  | 39. Cap screw               | 61. Rod clip            |
| 18. Flange head screw          | 40. Shaft                   | 62. Rivet               |
| 19. Cap screw                  | 41. Thrust washer           | 63. Actuator bracket    |
| 20. Bearing cap                | 42. Lynch pin               | 64. Carriage screw      |
| 21. Jam nut                    | 43. Rod                     | 65. RH actuator         |
| 22. Cap screw                  | 44. Cap screw               | 66. LH actuator         |

## Removal

1. Park machine on a level surface, lower cutting units, stop engine, engage parking brake, and remove key from the ignition switch.

2. Remove cutting units from the pivot shaft of the front lift arms (see Cutting Unit Removal).

**NOTE:** Remove both spacers from the hydraulic cylinder shaft clevis when removing the right, front lift arm.

3. Disconnect hydraulic cylinder from the front lift arms by removing external retaining rings and pins.

4. Remove both flange head screws and carrier stop bracket from the lift arm pivot shafts.

5. Slide lift arm off the pivot shaft.

6. Disassemble lift arm as necessary using Figure 17 as a guide.

## Installation

1. Assemble lift arm using Figure 17 as a guide.

2. Slide lift arm onto the lift arm pivot shaft.

3. Secure carrier stop bracket with both flange head screws to the lift arm pivot shafts.

**NOTE:** Install both spacers to the hydraulic cylinder shaft clevis when installing the right, front lift arm.

4. Secure hydraulic cylinder to the lift arm with pins and external retaining rings.

5. Route hydraulic hoses so they clear the lift arm by 0.040 to 0.120 inch (1.0 to 3.0 mm) when the lift arm is fully raised (Fig. 19).

6. Adjust lift arms to proper clearance (see Adjust Front Lift Arms).

7. Install cutting unit to the front lift arm pivot shaft (see Cutting Unit Installation).

8. Grease front lift arms (see Lubrication in Chapter 2 – Product Records and Maintenance).

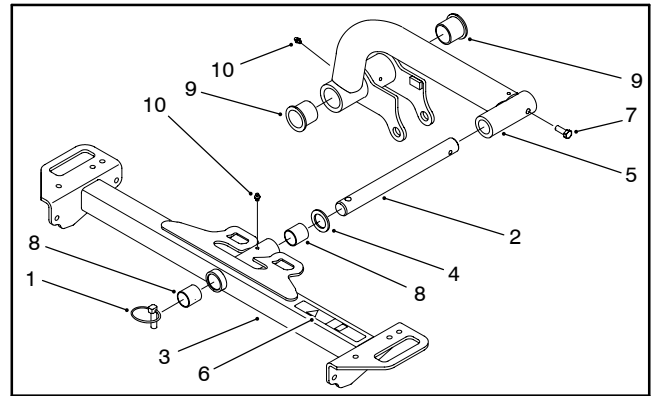

Figure 18

- |                             |                      |
|-----------------------------|----------------------|
| 1. Lynch pin                | 6. Pinch point decal |
| 2. Cutting unit pivot shaft | 7. Cap screw         |
| 3. Carrier frame            | 8. Frame bushing     |
| 4. Thrust washer            | 9. Lift arm bushing  |
| 5. Lift arm (LH shown)      | 10. Grease fitting   |

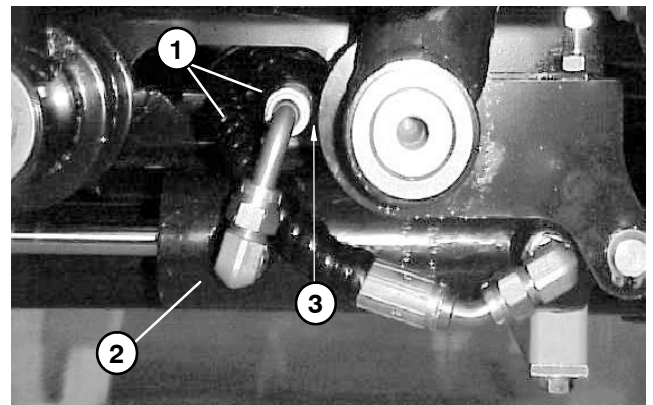

Figure 19

- |                       |              |
|-----------------------|--------------|
| 1. Hydraulic hoses    | 3. Clearance |
| 2. Hydraulic cylinder |              |

# Rear Lift Arm

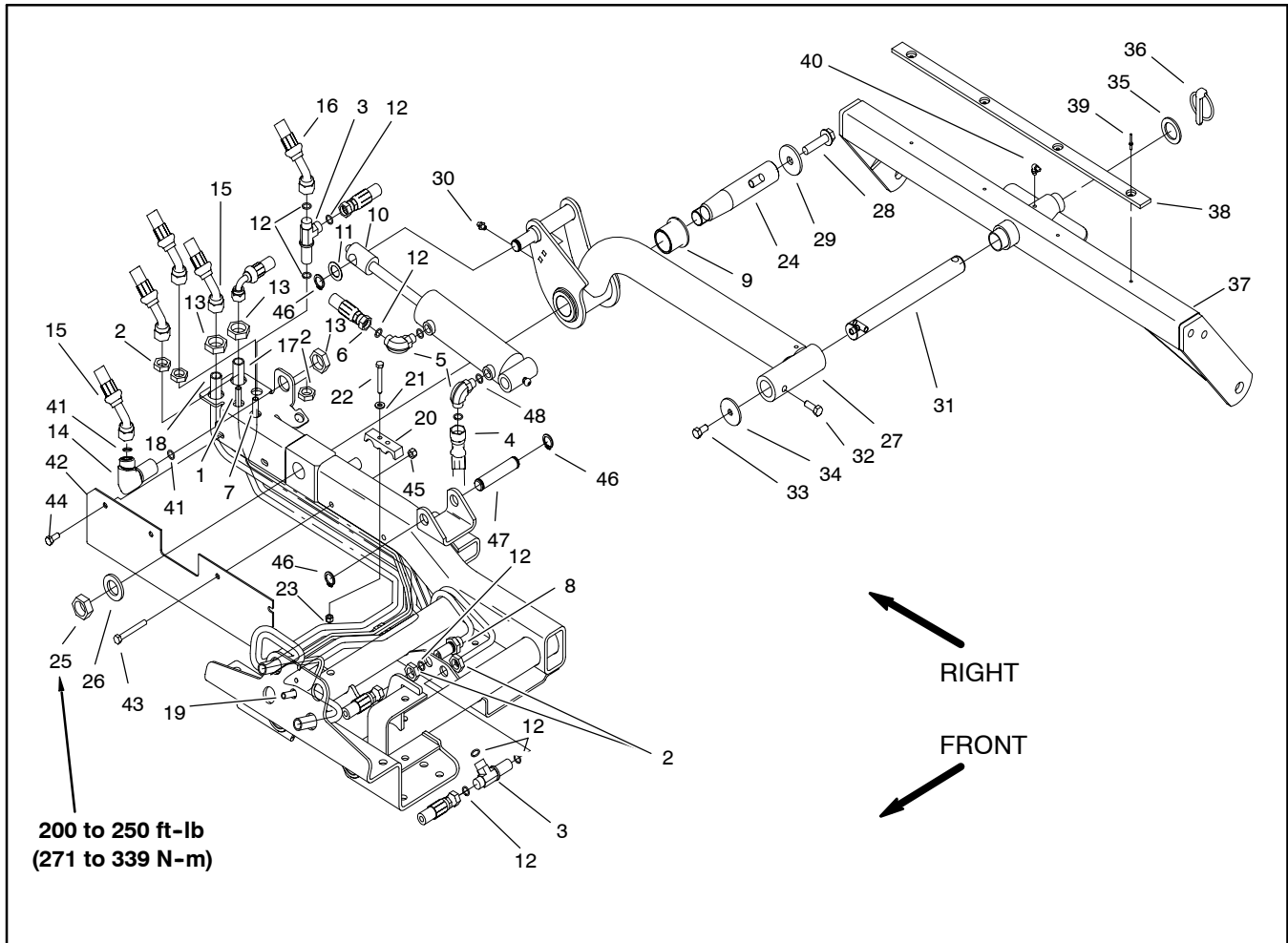

Figure 20

- |                               |                              |                             |
|-------------------------------|------------------------------|-----------------------------|
| 1. Hydraulic tube             | 17. Hydraulic tube           | 33. Cap screw               |
| 2. Bulkhead locknut           | 18. Hydraulic tube           | 34. Rebound washer          |
| 3. Hydraulic T-fitting        | 19. Hydraulic tube           | 35. Thrust washer           |
| 4. Hydraulic hose             | 20. Tube clamp               | 36. Lynch pin               |
| 5. 90° hydraulic fitting      | 21. Flat washer              | 37. Rear cutting unit frame |
| 6. Hydraulic hose             | 22. Cap screw                | 38. Wear strip              |
| 7. Hydraulic tube             | 23. Lock nut                 | 39. Pop rivet               |
| 8. Straight hydraulic fitting | 24. Rear pivot shaft         | 40. Grease fitting          |
| 9. Castor bushing             | 25. Jam nut                  | 41. O-ring                  |
| 10. Hydraulic lift cylinder   | 26. Washer                   | 42. Guard                   |
| 11. Thrust washer             | 27. Lift arm assembly        | 43. Cap screw               |
| 12. O-ring                    | 28. Flange head screw        | 44. Cap screw               |
| 13. Bulkhead locknut          | 29. Thrust washer            | 45. Lock nut                |
| 14. Bulkhead elbow union      | 30. Grease fitting           | 46. External retaining ring |
| 15. Hydraulic hose            | 31. Cutting unit pivot shaft | 47. Pin                     |
| 16. Hydraulic hose            | 32. Cap screw                | 48. O-ring                  |

## Removal

1. Park machine on a level surface, lower cutting units, stop engine, engage parking brake, and remove key from the ignition switch.
2. Remove cutting unit from the pivot shaft of the rear lift arm (see Cutting Unit Removal).
3. Remove external retaining ring and thrust washer from the lift cylinder shaft of the rear lift arm.
4. Remove flange head screw and thrust washer from the rear pivot shaft.
5. Slide rear lift arm from rear pivot shaft and hydraulic cylinder.
6. Disassemble lift arm as necessary using Figure 20 as a guide.

## Installation

1. Assemble lift arm using Figure 20 as a guide.
  - A. If the rear lift arm pivot shaft (item 24) was removed from frame, thoroughly clean tapered surfaces of shaft and frame. Position pivot shaft to frame and secure with washer and jam nut. Torque jam nut from 200 to 250 ft-lb (271 to 339 N-m).
  - B. If the cutting unit pivot shaft (item 31) was removed from lift arm, apply antiseize lubricant to pivot shaft before inserting into lift arm. Secure pivot shaft with two (2) cap screws (items 32 and 33) and washer (item 34).

2. Slide rear lift arm onto rear pivot shaft making sure that the lift cylinder shaft of the rear lift arm slides into the clevis of the hydraulic cylinder.
3. Secure hydraulic cylinder clevis to the lift cylinder shaft of the rear lift arm with the thrust washer and external retaining ring.
4. Install rear cutting unit to the pivot shaft of the rear lift arm (see Cutting Unit Removal).
5. Adjust lift arm to proper clearance (see Adjust Rear Lift Arm).

**IMPORTANT: Make sure hoses are free of twists and sharp bends. Raise cutting units and shift them to the left. Rear cutting unit hoses must not contact the traction cable bracket. If required, reposition fittings and hoses.**

6. Grease rear lift arm (see Lubrication in Chapter 2 – Product Records and Maintenance).

## Sidewinder Carrier

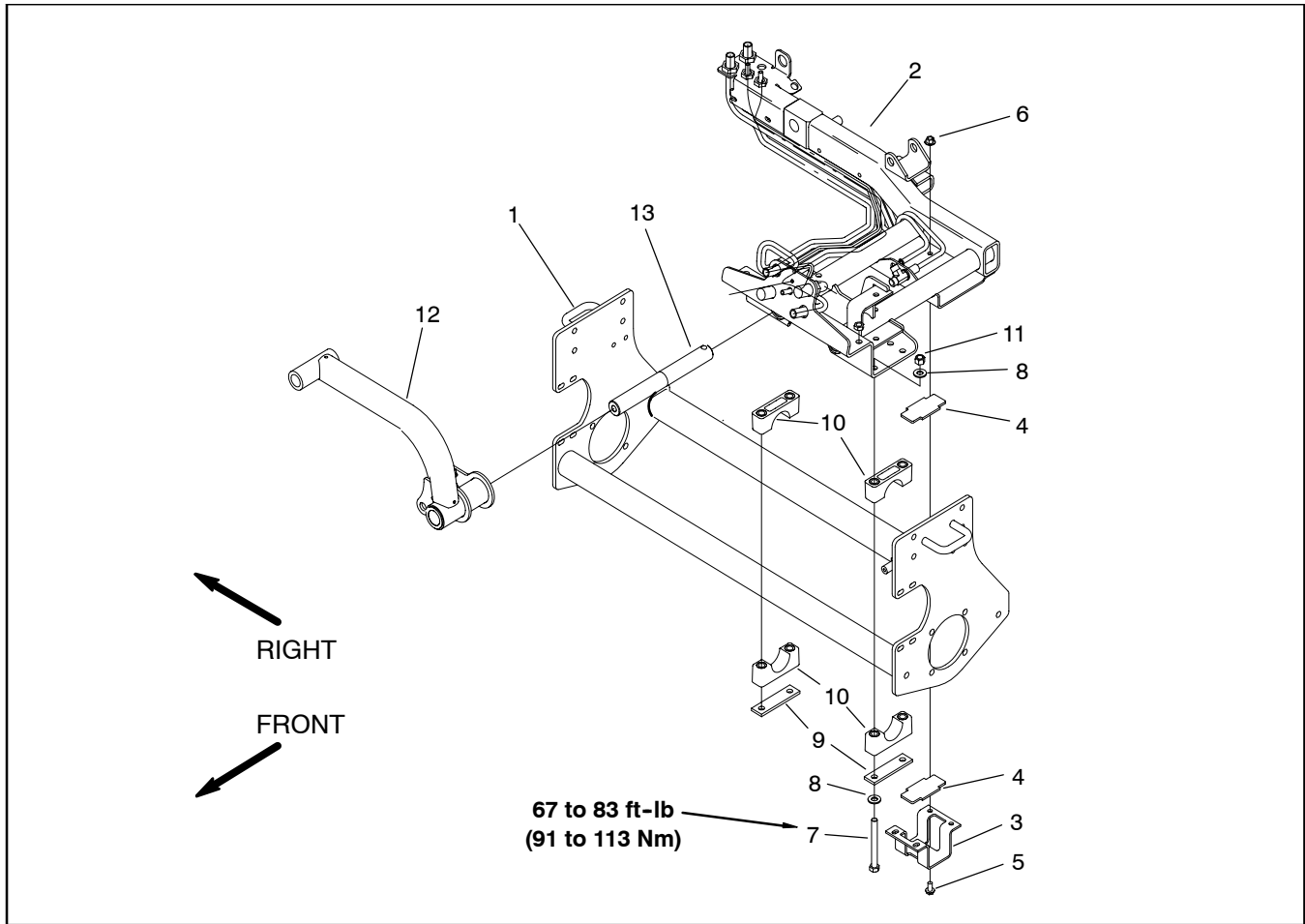

Figure 21

- |                                |                      |                         |
|--------------------------------|----------------------|-------------------------|
| 1. Lower frame                 | 6. Flange nut        | 10. Bearing cap         |
| 2. Sidewinder carrier assembly | 7. Cap screw         | 11. Lock nut            |
| 3. Slide bracket               | 8. Thrust washer     | 12. Liftarm (RH shown)  |
| 4. Plastic slide               | 9. Slide support bar | 13. Liftarm pivot shaft |
| 5. Flange head screw           |                      |                         |

### Disassembly

1. Park machine on a level surface, lower cutting units, stop engine, engage parking brake, and remove key from the ignition switch.
2. Disassemble sidewinder carrier as needed using Figures 17, 20, and 21 as guides.

### Assembly

1. Assemble sidewinder carrier using Figures 21 as guide.
  - A. Do not lubricate sidewinder cross tube as bearing caps and slides are self lubricating.
  - B. Tighten the bearing cap screws from 67 to 83 ft-lb (91 to 113 Nm).
2. Use Figures 17 and 20 to complete the assembly process (see Front Lift Arms and Rear Lift Arm).

## Hood Removal

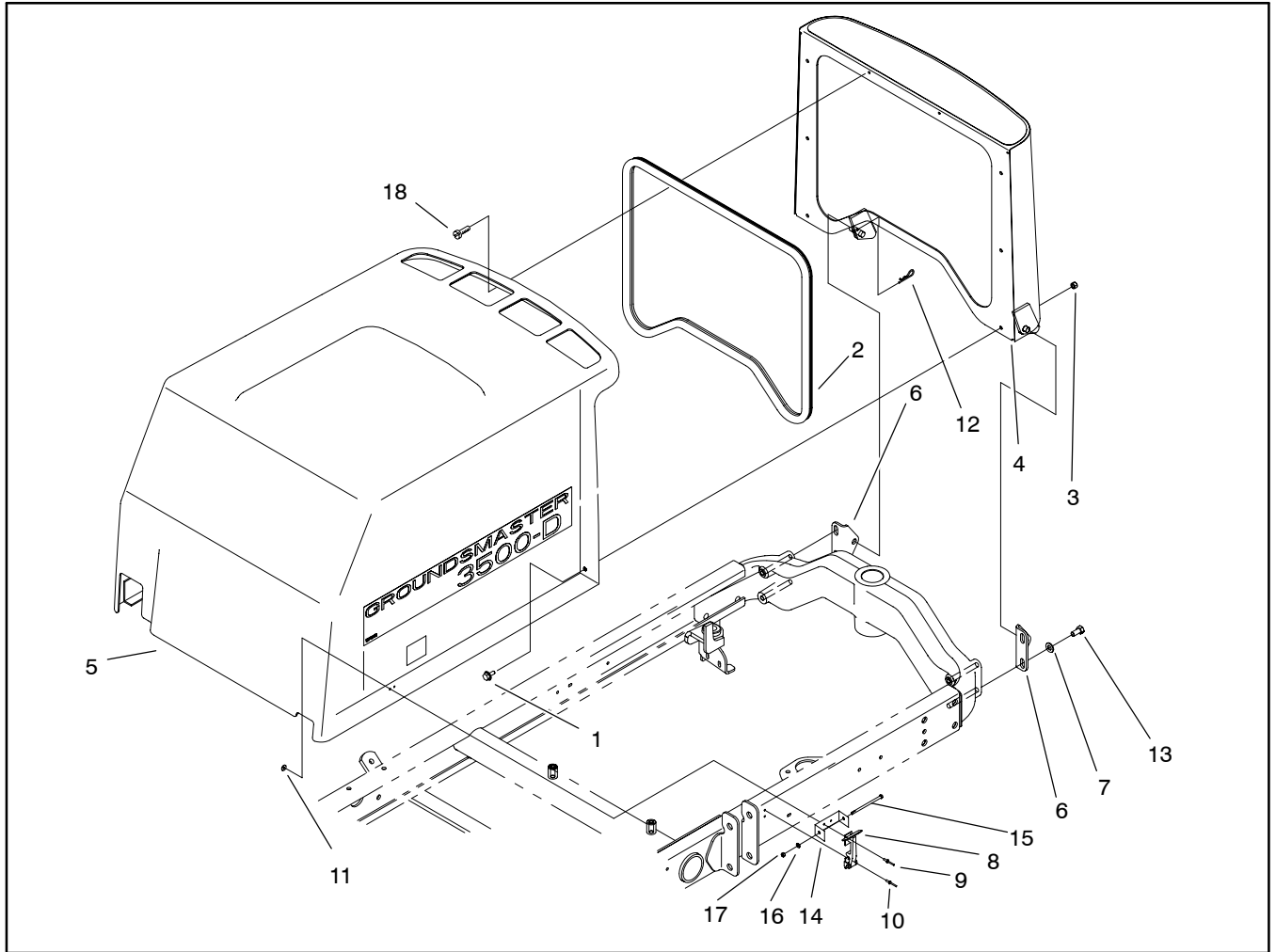

Figure 22

- 1. Flange screw
- 2. Trim-seal
- 3. Locknut
- 4. Hood screen
- 5. Hood
- 6. Pivot bracket

- 7. Flat washer
- 8. Flex draw latch
- 9. Rivet
- 10. Pop rivet
- 11. Washer
- 12. Hair pin

- 13. Cap screw
- 14. Lock bracket
- 15. Cap screw
- 16. Flat washer
- 17. Locknut

1. Park machine on a level surface, lower cutting units, stop engine, engage parking brake, and remove key from the ignition switch.
2. Unlatch and raise hood.
3. Remove hair pin securing hood pivot to pivot bracket.
4. Slide hood to right, lift other side and remove hood.
5. Reverse procedure to reinstall hood.

This page is intentionally blank.





# Cutting Units

## Table of Contents

SPECIFICATIONS .....	2	SERVICE AND REPAIRS .....	8
TROUBLESHOOTING .....	3	Blade Stopping Time .....	8
Factors That Can Affect Quality of Cut .....	3	Cutting Unit Removal and Installation .....	9
SPECIAL TOOLS .....	4	Cutting Blade Removal and Installation .....	10
ADJUSTMENTS .....	5	Inspecting and Sharpening Blade .....	10
Height-of-Cut Adjustment .....	5	Rear Roller .....	11
Adjust Roller Scraper .....	6	Rear Roller Service (Non-Greasable Bearings) .....	12
Blade Plane Inspection and Adjustment .....	7	Rear Roller Service (Greasable Bearings with Retaining Ring) .....	13
		Rear Roller Service (Greasable Bearings with Bearing Nut) .....	14
		Front Roller Service .....	16
		Blade Spindle Service .....	18
		Carrier Frame .....	20



# Specifications



**MOUNTING:** All cutting units are supported by equal length, independent lift arms and are interchangeable to all three cutting unit positions.

**CONSTRUCTION:** Deck chamber is welded 10 and 12 gauge steel. Deck frame is welded 1-1/2 inch square tubing with 7 gauge side supports.

**HEIGHT-OF-CUT RANGE:** 3/4 to 4 inch (1.91 to 10.16 cm) in 1/4 inch (.64 cm) increments. Height-of-cut adjustment is made by repositioning deck on deck frame.

**DECK DRIVE:** Closed loop, integrated relief, hydraulic system operates cutting deck hydraulic motors. Blade spindles are 1-1/4 inch shafts supported by greasable, tapered roller bearings.

**CUTTING BLADE:** Each cutting unit equipped with 27 inch (68.6 cm) length, .25 inch (6 mm) thick, heat treated, steel blade. Anti-scalp cup installed on cutting blade. The standard blade is optimized for most cutting applications. Optional high lift, angle sail, and Atomic blades are available for those situations where the standard blade is not ideal.

**DISCHARGE:** Clippings are discharged from the rear of the mowing decks. Pre-drilled mounting holes allow attachment of optional mulching baffle.

**CUTTING UNIT LIFT:** Cutting units are controlled with one lever.

**SUSPENSION SYSTEM:** A fully floating suspension with hydraulic counterbalance. Main center pivot allows side-to-side oscillation. Individual decks supported with two front rollers and one, full width, rear roller.

**WEIGHT:** Complete cutting unit weighs 190 lb (86 kg).

**OPTIONAL EQUIPMENT:** Refer to Cutting Unit Operator's Manual for cutting deck options.

# Troubleshooting

There are a number of factors that can contribute to unsatisfactory quality of cut, some of which may be turf conditions. Turf conditions such as excessive thatch, “sponginess” or attempting to cut off too much grass height may not always be overcome by adjusting the machine. It is important to remember that the lower the height-of-cut, the more critical these factors are.

Remember that the “effective” or actual height-of-cut depends on cutting unit weight and turf conditions. Effective height-of-cut will be different than the bench set height-of-cut.

## Factors That Can Affect Quality of Cut

Factor	Possible Problem/Correction
1. Maximum governed engine speed.	Check maximum governed engine speed. Adjust speed to specifications if necessary.
2. Blade speed.	All deck blades should rotate at the same speed.  See items in Troubleshooting Section of Chapter 4 - Hydraulic System.
3. Tire pressure.	Check each tire’s pressure. Adjust to pressures specified in Specifications Section of Chapter 6 - Wheels and Brakes.
4. Blade condition.	Sharpen blades if their cutting edges are dull or nicked.  Inspect blade sail for wear or damage. Replace blade if needed.
5. Mower housing condition.	Make sure that cutting chambers are in good condition.  Keep underside of deck clean. Debris buildup will reduce cutting performance.
6. Height-of-cut.	Make sure all cutting units are set at the same height-of-cut. Set units as specified in the Cutting Unit Operator’s Manual.
7. Cutting unit alignment and ground following.	Check lift arms and cutting unit pivot linkages for wear, damage, or binding. Also inspect for bent or damaged pivot shafts.
8. Roller condition.	All rollers should rotate freely. Replace roller bearings if worn or damaged.



# Adjustments



## CAUTION

Never install or work on the cutting units or lift arms with the engine running. Always stop engine and remove key first.

### Height-of-Cut Adjustment

**IMPORTANT:** This cutting deck often cuts approximately 1/4 inch lower than a reel cutting unit with the same bench setting. It may be necessary to have these rotary cutting deck's bench set 1/4 inch above that of reels cutting in the same area.

**NOTE:** Check carrier frame position before adjusting height-of-cut (See Carrier Frame).

1. Lower cutting deck to ground, stop engine, and remove key from ignition switch.
2. Loosen cap screw securing each height-of-cut bracket to height-of-cut plate (front and each side).
3. Beginning with front adjustment, remove cap screw.
4. While supporting deck chamber, remove spacer.
5. Move deck chamber to desired height-of-cut and install spacer into designated height-of-cut hole and slot.
6. Position tapped height-of-cut plate in line with spacer and install cap screw finger tight.
7. Repeat steps 4 - 6 for each side adjustment.
8. Tighten all three cap screws to 30 ft-lb (41 N-m).

**NOTE:** Adjustments of more than 1 1/2 inch may require temporary assembly to an intermediate height to prevent binding of the deck chamber.

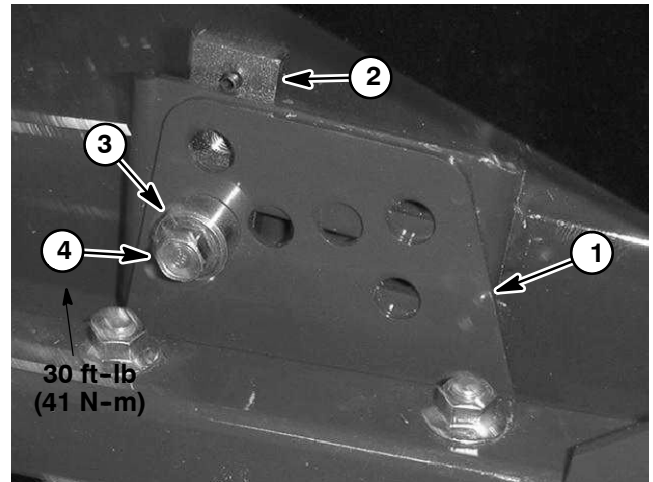

Figure 1

1. Height-of-cut bracket
2. Height-of-cut plate
3. Spacer
4. Cap screw

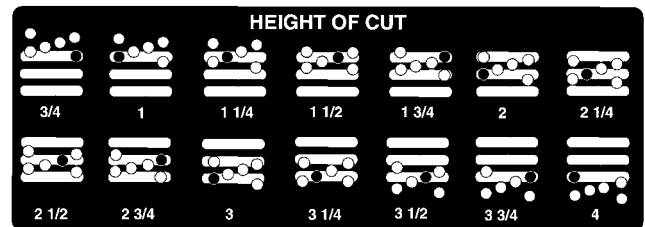

Figure 2

## Adjust Roller Scraper

If cutting deck is equipped with a rear roller scraper, there should be an even gap of .020 to .040 inch (.51 to 1.02 mm) between the scraper rod and rear roller.

Two styles of roller scrapers have been available for the Groundsmaster 3500-D. Early models used a scraper rod that was fastened to brackets with lock nuts (Fig. 3). The scraper system used on later models has a one piece scraper component (Fig. 4). The adjustment method for both styles is similar.

1. On scraper rods equipped with lock nuts (Fig. 3), loosen lock nut securing one end of scraper rod to mounting bracket. For proper roller scraper adjustment, there should be approximately .005 to .020 inch (.13 to .51 mm) end play in loosened rod.

2. Loosen left and right scraper bracket mounting fasteners only enough to allow mounting brackets to be adjusted:

A. Early models use two flange head screws on each scraper bracket.

B. Later models use one flange head screw and one cap screw with jam nut on each side of roller.

3. Slide scraper brackets up or down until a gap of .020 to .040 inch (.51 to 1.02 mm) is achieved between the scraper rod and roller.

4. Secure mounting bracket fasteners to 30 ft-lb (41 N-m).

5. On scraper rods equipped with lock nuts (Fig. 3), tighten scraper rod lock nut to 65 in-lb (8.5 N-m).

**NOTE:** On scraper rods equipped with lock nuts (Fig. 3), if one side of scraper rod becomes worn, it can be rotated in the mounting brackets 180 degrees for a new edge.

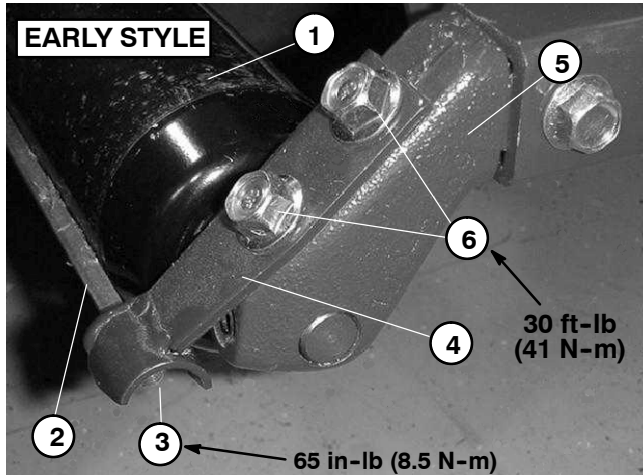

Figure 3

- |                |                      |
|----------------|----------------------|
| 1. Rear roller | 4. Scraper bracket   |
| 2. Scraper rod | 5. Roller mount      |
| 3. Lock nut    | 6. Flange head screw |

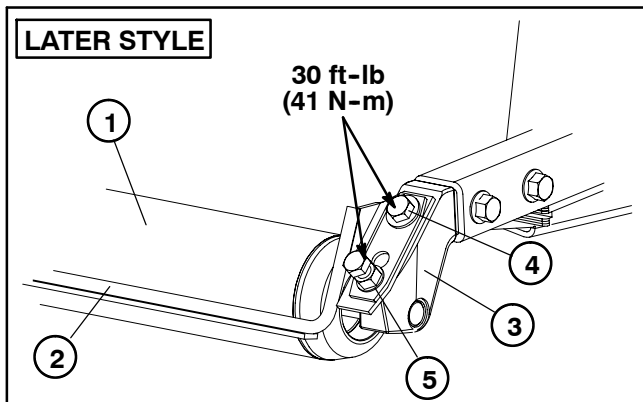

Figure 4

- |                 |                           |
|-----------------|---------------------------|
| 1. Rear roller  | 4. Flange head screw      |
| 2. Scraper rod  | 5. Cap screw with jam nut |
| 3. Roller mount |                           |

## Blade Plane Inspection and Adjustment

If a solid object is struck by the cutting deck, the blade plane of the deck should be inspected.

### Blade Plane Inspection

1. Remove cutting unit to be inspected (see Cutting Unit Removal and Installation).
2. Use hoist (or minimum of two people) and place cutting deck on flat table.
3. Mark one end of blade with paint pen or marker. Use this end of blade to check all heights.
4. Position cutting edge of marked end of blade at 12 o'clock (straight ahead in direction of mowing). Measure height from table to cutting edge of blade.
5. Rotate marked end of blade to the 3 and 9 o'clock positions and measure heights.
6. Compare 12 o'clock measured height to the height-of-cut setting. It should be within .090 inch (2.3 mm). The 3 and 9 o'clock heights should be  $.150 \pm .090$  inch ( $3.8 \pm 2.3$  mm) higher than the 12 o'clock setting and within .090 inch (2.3 mm) of each other. If any of these measurements are not within specification, proceed to Adjusting Blade Plane.

### Adjusting Blade Plane

Start with front bracket adjustment and change one height-of-cut bracket at a time.

1. Remove height-of-cut bracket (front, left, or right) from deck frame.
2. Position .060 inch and/or .030 inch shims between the deck frame and bracket to achieve the desired blade height setting.
3. Install height-of-cut bracket to deck frame with remaining shims assembled below the height-of-cut bracket.

**NOTE:** Socket head bolt and spacer for front bracket are held together with Loctite to prevent spacer from falling inside the deck frame.

4. Secure front height-of-cut bracket to deck frame with socket head bolt/spacer and flange nut.
5. Verify 12 o'clock height. Re-adjust if needed.

6. Determine if one or both (RH and LH) height-of-cut brackets need to be adjusted. If the 3 or 9 o'clock side is  $.150 \pm .090$  inch ( $3.8 \pm 2.3$  mm) higher than the new front height, then no adjustment is needed for that side. Adjust other side (if needed) to within  $\pm .090$  inch ( $\pm 2.3$  mm) of correct side.

7. Adjust right and/or left height-of-cut brackets by repeating steps 1 thru 3.

8. Secure right and/or left height-of-cut brackets with carriage bolts and flange nuts.

9. Verify 12, 3, and 9 o'clock heights.

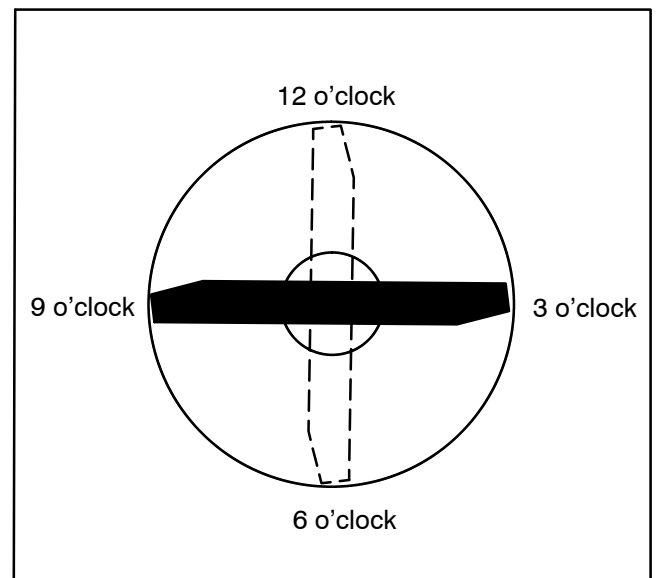

Figure 5

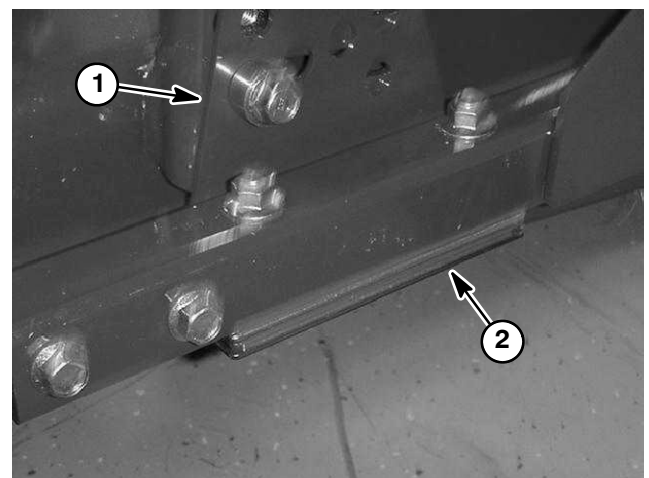

Figure 6

1. Height-of-cut bracket
2. Shims

# Service and Repairs



## CAUTION

Never install or work on the cutting units or lift arms with the engine running. Always stop engine and remove key first.

---

### Blade Stopping Time

The blades of the cutting deck are to come to a complete stop in approximately 5 seconds after the cutting deck engagement switch is shut down.

**NOTE:** When checking blade stopping time, make sure the decks are lowered onto a clean section of turf or hard surface to avoid dust and debris.

To verify blade stopping time, have a second person stand back a safe distance from the machine and watch the blade on one of the cutting decks. When the machine operator disengages the cutting decks, record the time it takes for the blade to come to a complete stop. If this time is greater than 7 seconds, the braking valve (BV) on the hydraulic manifold needs adjustment (see Braking Valve Adjustment in the Adjustments section of Chapter 4 - Hydraulic System).



## Cutting Unit Removal and Installation

### Removal

1. Position machine on a clean, level surface. Lower cutting units, stop engine, engage parking brake, and remove key from the ignition switch.
2. Remove two cap screws that secure hydraulic motor to the cutting unit (Fig. 7). Remove hydraulic motor from deck and O-ring from top of spindle housing.
3. Cover top of spindle housing to prevent contamination. Spindle plug (Toro Part # 94-2703) can be used to cover spindle.
4. Remove lynch pin securing deck carrier frame to lift arm pivot shaft (Fig. 8).
5. Note location of thrust washer on lift arm pivot shaft.
6. Remove cutting unit from lift arm pivot shaft. Roll the cutting unit away from the traction unit.

### Installation

1. Position machine on a clean, level surface. Lower lift arms, stop engine, engage parking brake, and remove key from the ignition switch.
2. Install cutting unit onto pivot shaft:
  - A. On the front cutting units, slide thrust washer and then cutting unit carrier frame onto pivot shaft. Note: front right and left carrier frames are identical except for the location of the service latch rod (Fig. 9).
  - B. On the rear cutting unit, slide cutting unit carrier frame and then thrust washer onto pivot shaft.
3. Install lynch pin onto the pivot shaft (Fig. 8).
4. Remove plug or cover from top of spindle housing, if installed.
5. Position O-ring to top of spindle housing. Install hydraulic motor to the cutting unit with two cap screws (Fig. 7).
6. Lubricate spindle and carrier frame grease fittings (see Lubrication in Chapter 2 - Product Records and Maintenance).

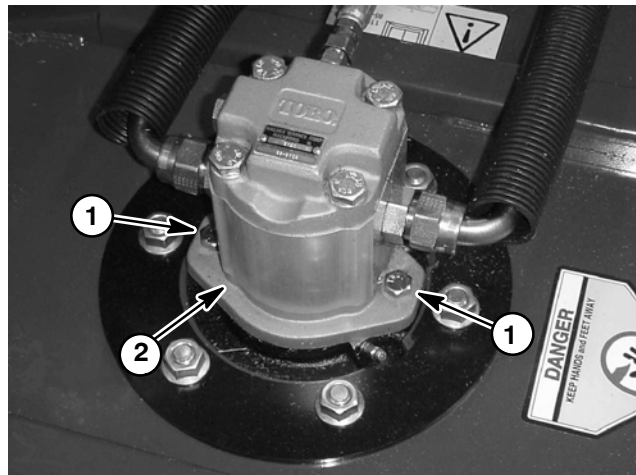

Figure 7

1. Cap screw      2. Hydraulic motor

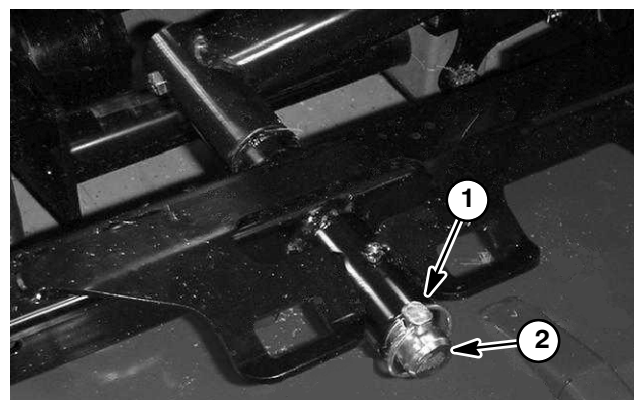

Figure 8

1. Lynch pin      2. Lift arm pivot shaft

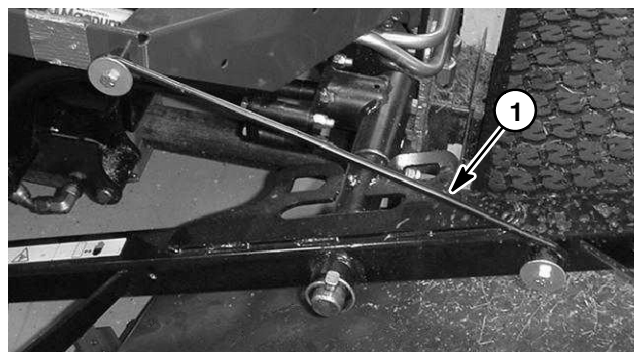

Figure 9

1. Service latch rod

## Cutting Blade Removal and Installation

The cutting blade must be replaced if a solid object is hit, the blade is out of balance, or if the blade is bent. Always use genuine TORO replacement blades to be sure of safety and optimum performance. Never use replacement blades made by other manufacturers because they could be dangerous.

1. Park machine on a level surface, raise cutting units to highest position, stop engine, engage parking brake, and remove key from the ignition switch. Block cutting deck to prevent it from falling accidentally.
2. Grasp end of cutting blade using a rag or thickly padded glove. Remove blade bolt, anti-scalp cup, and blade from spindle shaft.
3. Install blade (sail facing toward cutting deck), anti-scalp cup, and blade bolt. Tighten bolt from 85 to 110 ft-lb (115 to 149 N-m).

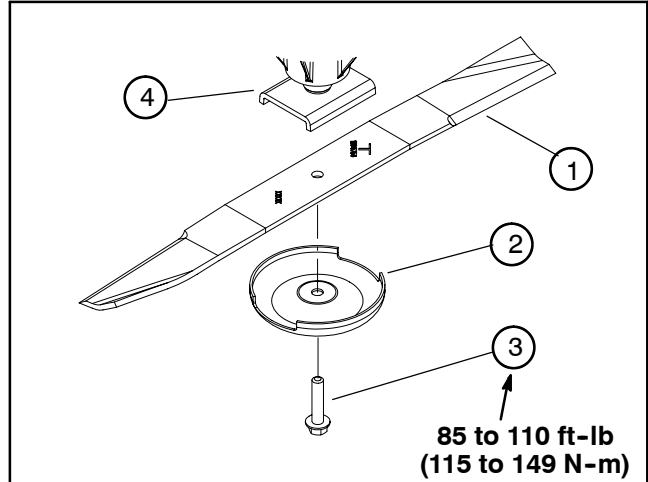

Figure 10

- |                   |                  |
|-------------------|------------------|
| 1. Cutting blade  | 3. Blade bolt    |
| 2. Anti-scalp cup | 4. Spindle shaft |

## Inspecting and Sharpening Blade

1. Park machine on a level surface, raise cutting units to highest position, stop engine, engage parking brake, and remove key from the ignition switch. Block cutting deck to prevent it from falling accidentally.

 **WARNING**

**Do not try to straighten a blade that is bent. Never weld a broken or cracked blade. Always use a new blade to assure continued safety certification of the product.**

2. Examine cutting ends of the blade carefully, especially where the flat and curved (sail) parts of the blade meet (Fig. 11). Since sand and abrasive material can wear away the metal that connects the flat part and sail of the blade, check the blade before using the machine. If wear is noticed, replace the blade.

3. Inspect cutting edges of all blades. Sharpen the cutting edges if they are dulled or nicked. Sharpen only the top of the cutting edge and maintain the original cutting angle to make sure of sharpness (Fig. 12). The blade will remain balanced if the same amount of metal is removed from both cutting edges.

4. To check blade for being straight and parallel, remove blade (see Cutter Blade Removal and Installation) and lay it on a level surface. The ends of the blade must be slightly lower than the center and the cutting edge must be lower than the heel of the blade. If the blade is higher at the ends than the center, or if cutting edge is

higher than the heel, the blade is bent or warped, and must be replaced.

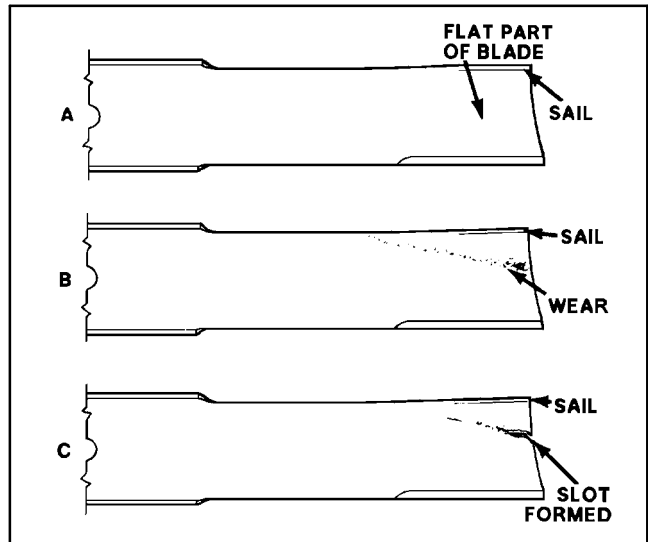

Figure 11

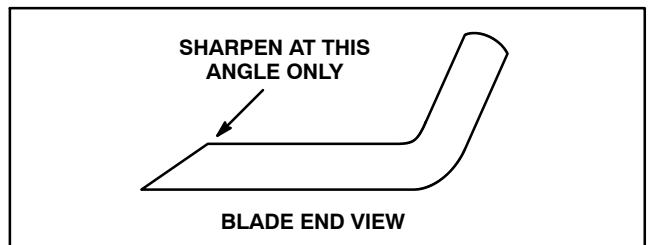

Figure 12

## Rear Roller

Three types of rear rollers have been used on the Groundsmaster 3500-D. One roller design has sealed bearings with no grease fittings on the roller shaft. The second design has grease fittings in the roller shaft ends. The third design has grease fittings incorporated into the roller fasteners. Removal and installation of the rear roller from the cutting deck is the same, regardless of roller type.

### Removal (Fig. 13)

1. Park machine on a level surface, lower cutting units, stop engine, engage parking brake, and remove key from the ignition switch.
2. If cutting deck is equipped with roller scraper, remove roller scraper from deck.
  - A. If equipped with early style roller scraper (Fig. 14), loosen one locknut that secures roller scraper rod to mounting bracket.
  - B. Remove fasteners securing left and right scraper rod brackets to roller mounts (Figs. 14 and 15).
  - C. Remove scraper rod assembly from cutting deck.
3. Remove four (4) mounting screws securing roller mounts to rear of deck frame. Remove roller mounts and rear roller assembly from deck frame.
4. Loosen fasteners securing each end of roller to roller mounts. Remove mounts from roller.

### Installation (Fig. 13)

1. Place roller assembly into roller mounts.
2. Install roller and roller mount assembly into rear of deck frame. Secure assembly to deck frame with flange head screws.

**IMPORTANT:** If roller design includes grease fittings in roller fasteners (items 8 and 9 in Fig. 13), make sure the grease groove in each roller mount aligns with the grease hole in each end of the roller shaft. To help align the groove and hole, there is also an alignment mark on one end of the roller shaft.

3. Tighten fasteners that secure each end of roller to roller mounts.
4. If equipped, install scraper rod assembly to roller mounts. Adjust scraper rod (see Adjust Roller Scraper in the Adjustments section).
5. If roller design allows greasing, lubricate roller grease points.

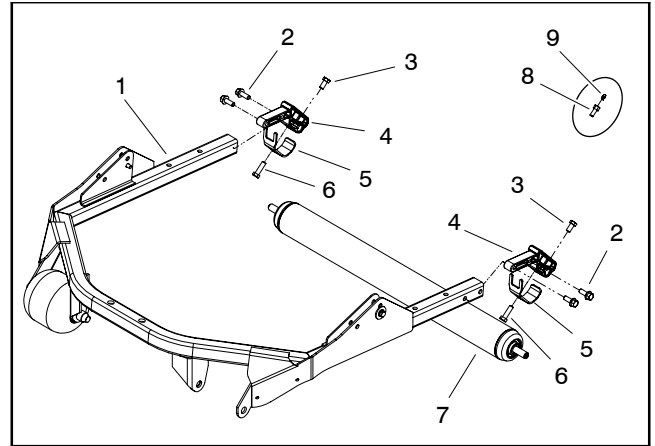

Figure 13

- |                       |                            |
|-----------------------|----------------------------|
| 1. Cutting deck frame | 6. Cap screw               |
| 2. Flange head screw  | 7. Rear roller             |
| 3. Cap screw          | 8. Cap screw (if equipped) |
| 4. Roller mount       | 9. Grease fitting          |
| 5. Skid bracket       |                            |

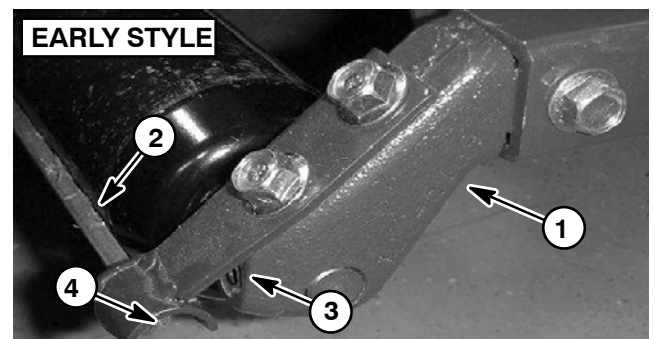

Figure 14

- |                              |              |
|------------------------------|--------------|
| 1. Roller mount              | 3. Set screw |
| 2. Scraper rod (early style) | 4. Locknut   |

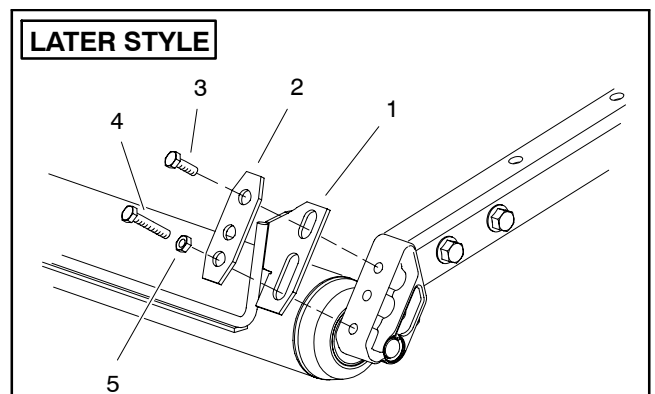

Figure 15

- |                   |              |
|-------------------|--------------|
| 1. Roller scraper | 4. Cap screw |
| 2. Scraper plate  | 5. Jam nut   |
| 3. Cap screw      |              |

## Rear Roller Service (Non-Greasable Bearings)

### Seal Removal (Fig. 16)

1. Using a 1/4 inch thick, 3" X 3" square piece of steel, make a seal removal tool as shown in Figure 17.
2. Slide seal removal tool over roller shaft.
3. Using the tool as a template, locate, mark, and drill two 7/64 inch (.109 inch diameter) holes in outer face of seal.
4. Screw two No. 8 (.164 inch diameter) by 3/4 inch long self-tapping screws into outer face of seal.
5. Install two 1/4-20 by 1 inch long cap screws into seal removal tool.
6. Alternately tighten cap screws to pull seal out of roller assembly.

**NOTE:** Seals will be destroyed when servicing the rear roller. Do not re-use seals that have been removed.

### Bearing Removal (Fig. 16)

**NOTE:** The bearings are pressed onto the roller shaft and loose fit into the roller.

1. Remove seals from roller. Remove retaining rings from roller shaft: catch ring removal notch with pick and pull ring from shaft.
2. Loosely secure roller assembly in bench vise and lightly tap one end of roller shaft until free from bearing and housing.
3. Remove second bearing from shaft by supporting bearing on inner race and tapping on roller shaft.
4. Discard removed bearings. Inspect shaft, retaining rings, and roller for damage. Replace components as needed.

### Roller Assembly (Fig. 16)

1. Press new bearing onto one end of roller shaft. Apply pressure equally to inner and outer bearing races.
2. Place spiral retaining ring on same end of shaft as installed bearing.
3. Install shaft with single bearing into roller.
4. Install second new bearing onto roller shaft. Apply pressure equally to inner and outer bearing races. The inner race will contact shoulder of shaft before outer race contacts shoulder of roller.

5. Install second spiral retaining ring onto roller shaft to secure second bearing.
6. Install new seals to .030 inch (.76 mm) recessed into roller.

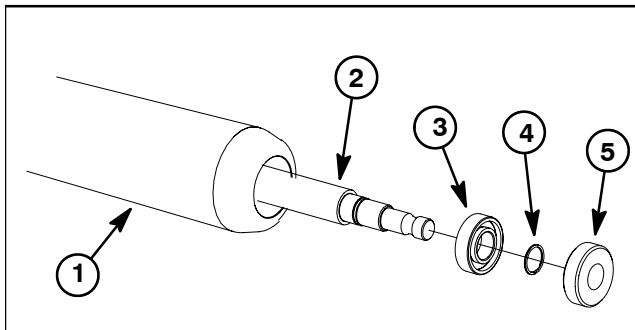

Figure 16

- |                 |                   |
|-----------------|-------------------|
| 1. Roller       | 4. Retaining ring |
| 2. Roller shaft | 5. Oil seal       |
| 3. Bearing      |                   |

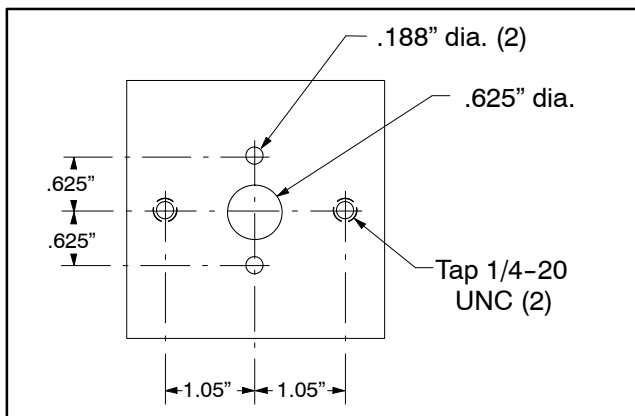

Figure 17

## Rear Roller Service (Greaseable Bearings with Retaining Ring)

### Roller Disassembly (Fig. 18)

1. Remove retaining ring from both ends of roller.
2. Hit end of roller shaft with a soft face hammer to remove seals and bearing from one end of roller. Hit other end of roller shaft to remove seals and bearing from other end of roller. Be careful not to drop roller shaft.
3. Discard seals and bearings.

### Roller Assembly (Fig. 18)

**NOTE:** A soft face hammer can be used with the special tools listed (see Special Tools) to assemble the roller, however use of a press is recommended.

1. Use installation tool TOR4065 and handle TOR4073 to install inner oil seal into each end of roller tube.
2. Install ball bearings:

**NOTE:** Ball bearings have a press fit into the roller tube and a slip fit onto the roller shaft.

**IMPORTANT:** If ball bearing has a seal on one side, install bearing with seal orientated toward the outside of the roller.

- A. Use tool TOR4066 and handle TOR4073 to install ball bearing into one end of roller tube.
  - B. Install roller shaft from opposite end of roller. Be careful not to damage the inner oil seals.
  - C. Put roller in a vertical position and support shaft and bearing with tool TOR4067.
  - D. Use tool TOR4067 to install second ball bearing.
3. Use tool TOR4068 to install inner seal.
  4. Use tool TOR4069 to install outer seal.
  5. Install retaining ring so that side with sharp edges faces end of roller (out).
  6. Use tool TOR4071 to install outer oil seal.
  7. Use tool TOR4067 to install washer.
  8. Put opposite end of roller facing up and support bottom end with tool TOR4067. Repeat steps 3 - 7.
  9. Use a hand operated grease gun and No. 2 general purpose lithium base grease to lubricate bearings until grease appears at washer. Wipe off excess grease.

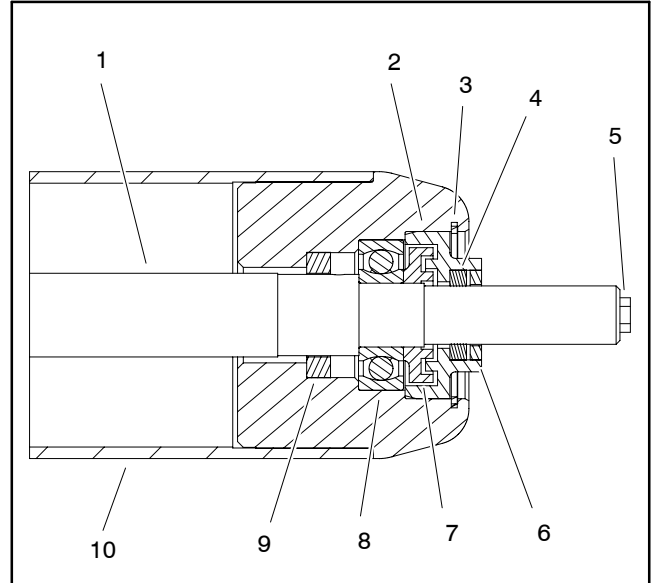

Figure 18

- |                   |                   |
|-------------------|-------------------|
| 1. Roller shaft   | 6. Washer         |
| 2. Outer seal     | 7. Inner seal     |
| 3. Retaining ring | 8. Ball bearing   |
| 4. Outer oil seal | 9. Inner oil seal |
| 5. Grease fitting | 10. Roller tube   |

## Rear Roller Service (Greaseable Bearings with Bearing Nut)

### Disassembly (Fig. 19)

1. Remove bearing lock nut from each end of roller shaft.
2. Loosely secure roller assembly in bench vise and lightly tap one end of roller shaft until outer seals and bearing are removed from opposite end of roller tube. Remove second set of outer seals and bearing from roller tube by tapping on opposite end of shaft. Remove shaft from roller tube.
3. Carefully remove inner seal from both ends of roller tube taking care to not damage tube surfaces.
4. Discard removed seals and bearings.
5. Clean roller shaft and all surfaces on the inside of the roller tube. Inspect components for wear or damage. Also, carefully inspect seating surface and threads of bearing lock nuts. Replace all damaged components.

### Assembly (Fig. 19)

1. Install inner seals into roller tube making sure that seal lip (and garter spring) faces end of tube. Use inner seal tool (see Special Tools) and soft face hammer to fully seat seals against roller shoulder (Fig. 20). Apply a small amount of grease around the lip of both inner seals after installation.

**IMPORTANT: During assembly process, frequently check that bearings rotate freely and do not bind. If any binding is detected, consider component removal and reinstallation.**

2. Install new bearing and outer seals into one end of roller tube:

A. Position a new bearing into one end of roller tube. Use bearing/outer seal tool (see Special Tools) with a soft face hammer to fully seat bearing against roller shoulder (Fig. 21). After bearing installation, make sure that it rotates freely with no binding.

B. Apply a small amount of grease around the lip of both outer seals.

C. Install first outer seal into roller tube making sure that seal lip (and garter spring) faces end of tube. Use bearing/outer seal tool (see Special Tools) and soft face hammer to lightly seat seal against roller shoulder (Fig. 22). Make sure that bearing still freely rotates after seal installation.

D. Using the same process, install second outer seal making sure to not crush the installed outer seal. Again, make sure that bearing still freely rotates.

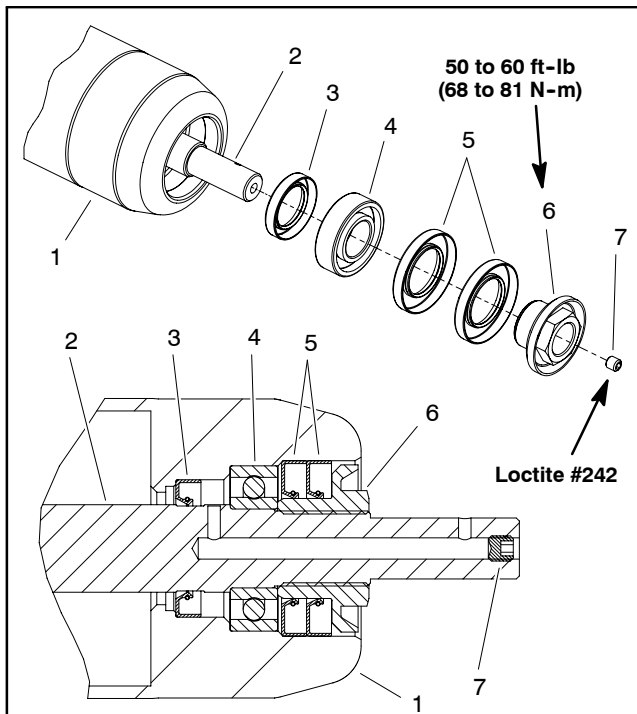

Figure 19

- |                 |                     |
|-----------------|---------------------|
| 1. Roller tube  | 5. Outer seal       |
| 2. Roller shaft | 6. Bearing lock nut |
| 3. Inner seal   | 7. Set screw        |
| 4. Bearing      |                     |

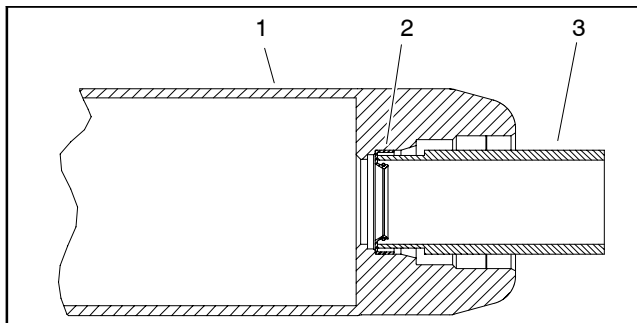

Figure 20

- |                |                    |
|----------------|--------------------|
| 1. Roller tube | 3. Inner seal tool |
| 2. Inner seal  |                    |

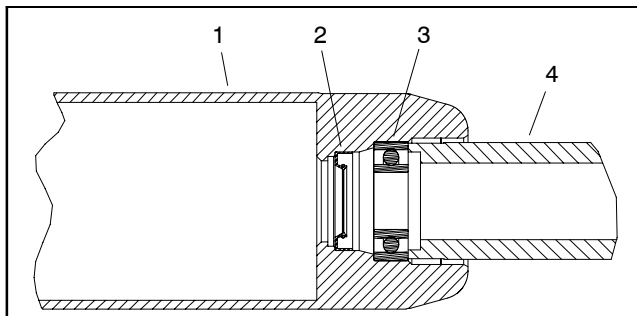

Figure 21

- |                |                            |
|----------------|----------------------------|
| 1. Roller tube | 4. Washer                  |
| 2. Inner seal  | 5. Bearing/outer seal tool |
| 3. Bearing     |                            |

3. From the roller tube end with only the inner seal installed, carefully install the roller shaft into the roller tube. Make sure that seals are not damaged as shaft is installed.

4. Install new bearing and outer seals into second end of roller tube:

A. Position a second new bearing to roller shaft and tube. Position washer (see Special Tools) on bearing to allow pressing on both inner and outer bearing races simultaneously.

B. Use washer and bearing/outer seal tool (see Special Tools) with a soft face hammer to fully seat bearing (Fig. 23). After bearing installation, make sure that shaft freely rotates and that no binding is detected. If necessary, lightly tap bearing and/or shaft ends to align shaft and bearings. Remove washer from roller.

C. Apply a small amount of grease around the lip of both outer seals.

D. Carefully install first outer seal into roller tube making sure that seal lip (and garter spring) faces end of tube. Use bearing/outer seal tool (see Special Tools) and soft face hammer to lightly seat seal (Fig. 24). Make sure that shaft and bearings still freely rotate after seal installation.

E. Using the same process, install second outer seal making sure to not crush the installed outer seal. Again, make sure that shaft and bearings still freely rotate.

**IMPORTANT: Make sure that all grease is removed from shaft threads to prevent bearing lock nut loosening.**

5. Thoroughly clean threads on both ends of roller shaft.

**NOTE:** If original bearing lock nut(s) are being used, apply Loctite #242 (or equivalent) to threads of lock nut(s).

6. Install bearing lock nut onto each end of the roller shaft. Make sure that outer seals are not damaged during nut installation. Torque lock nuts from 50 to 60 ft-lb (68 to 81 N-m).

7. If set screw was removed from either end of roller shaft, apply Loctite #242 (or equivalent) to threads of removed set screw and install into roller shaft. Tighten set screw until it bottoms in shaft and is recessed in shaft.

**IMPORTANT: When roller assembly is installed to cutting deck, make sure that grease groove in each roller mount aligns with the grease hole in each end of roller shaft.**

**NOTE:** After roller is installed to cutting deck, lubricate roller grease fittings, rotate roller to properly distribute grease in bearings and clean excess grease from roller ends. A properly assembled roller should rotate with less than 5 in-lbs (0.68 N-m) resistance.

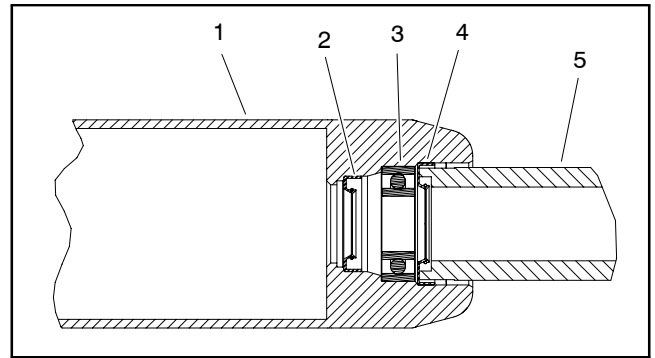

Figure 22

- |                |                            |
|----------------|----------------------------|
| 1. Roller tube | 4. Outer seal              |
| 2. Inner seal  | 5. Bearing/outer seal tool |
| 3. Bearing     |                            |

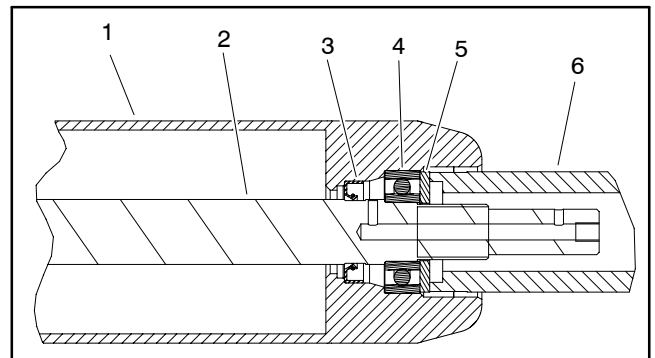

Figure 23

- |                 |                            |
|-----------------|----------------------------|
| 1. Roller tube  | 4. Bearing                 |
| 2. Roller shaft | 5. Washer                  |
| 3. Inner seal   | 6. Bearing/outer seal tool |

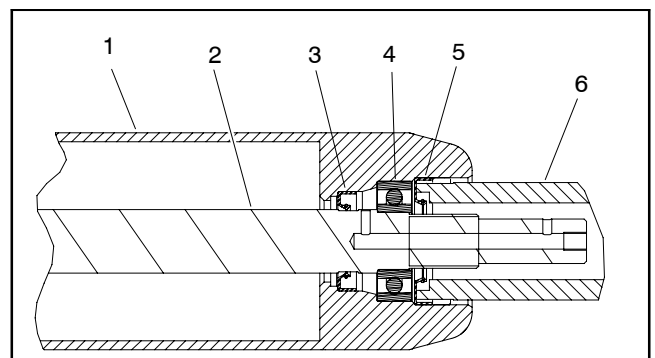

Figure 24

- |                 |                            |
|-----------------|----------------------------|
| 1. Roller tube  | 4. Bearing                 |
| 2. Roller shaft | 5. Outer seal              |
| 3. Inner seal   | 6. Bearing/outer seal tool |

## Front Roller Service

### Disassembly (Fig. 25)

1. Remove roller mounting bolt.
2. Remove roller assembly from carrier frame.
3. To remove bearings and spacer:
  - A. Insert punch through end of roller and drive opposite bearing out by alternating taps to opposite side of inner bearing race. There should be a lip of inner race exposed for this process.
  - B. Remove spacer. Remove second bearing from roller using a press.
4. Inspect roller housing, bearings, and bearing spacer for damage or wear. Replace components as needed.

### Assembly (Fig. 25)

1. Install bearings and bearing spacer into roller:
  - A. Press first bearing into housing. Press on outer race only or equally on inner and outer races.
  - B. Insert bearing spacer.
  - C. Press second bearing into roller housing pressing equally on inner and outer races until the inner race comes in contact with the spacer.
2. Install roller assembly into deck frame.

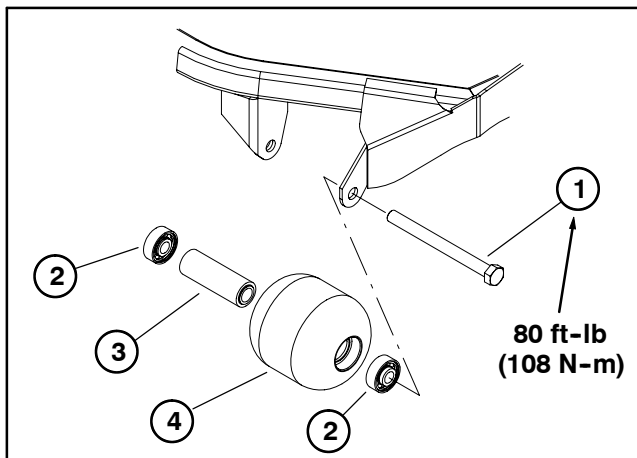

Figure 25

- |                  |                 |
|------------------|-----------------|
| 1. Mounting bolt | 3. Spacer       |
| 2. Bearing       | 4. Front roller |

**NOTE:** Securing roller assembly with a gap larger than .060 inch (1.52 mm) creates a side load on bearings and can lead to premature bearing failure.

3. Verify that there is no more than a .060 inch (1.52 mm) gap between roller assembly and the roller mount brackets of the deck frame. If this gap is larger than .060 inch (1.5 mm), shim excess clearance with 5/8" washers.
4. Insert mounting bolt and tighten to 80 ft-lb (108 N-m).



This page is intentionally blank.

## Blade Spindle Service

### Disassembly

1. Park machine on a level surface, lower cutting units, stop engine, engage parking brake, and remove key from the ignition switch.
2. Remove two cap screws that secure hydraulic motor to the cutting unit (Fig. 26). Remove hydraulic motor and O-ring from deck.
3. Cover top of spindle to prevent contamination. Spindle plug (Toro Part # 94-2703) can be used to cover spindle.
4. Start the engine and raise the cutting unit. Stop engine and remove key from the ignition switch. Block up the cutting unit so it cannot fall accidentally. If required for easier service, remove cutting unit (see Cutting Unit Removal and Installation).
5. Remove cutting blade, anti-scalp cup and bolt (see Cutting Blade Removal and Installation).
6. Remove cap screws and flange nuts securing spindle housing to deck. Slide spindle housing assembly out the bottom of the deck. Remove spindle plate from top of deck.
7. Loosen and remove spindle nut from top of spindle shaft.
8. Press the spindle shaft out of the spindle housing using an arbor press. The shaft spacer remains on the spindle shaft as the shaft is being removed.
9. Remove seals from spindle housing.
10. Allow the bearings, inside spacer and spacer ring to fall out of the spindle housing.
11. Using a punch and hammer, drive both of the bearing cups out of the spindle housing. Also drive the large spacer out of the housing.
12. The large snap ring should remain inside the spindle housing because it is difficult to remove.

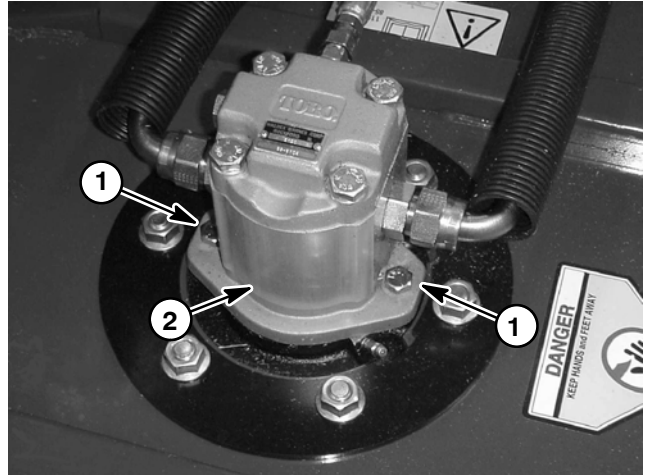

Figure 26

1. Cap screw
2. Hydraulic motor

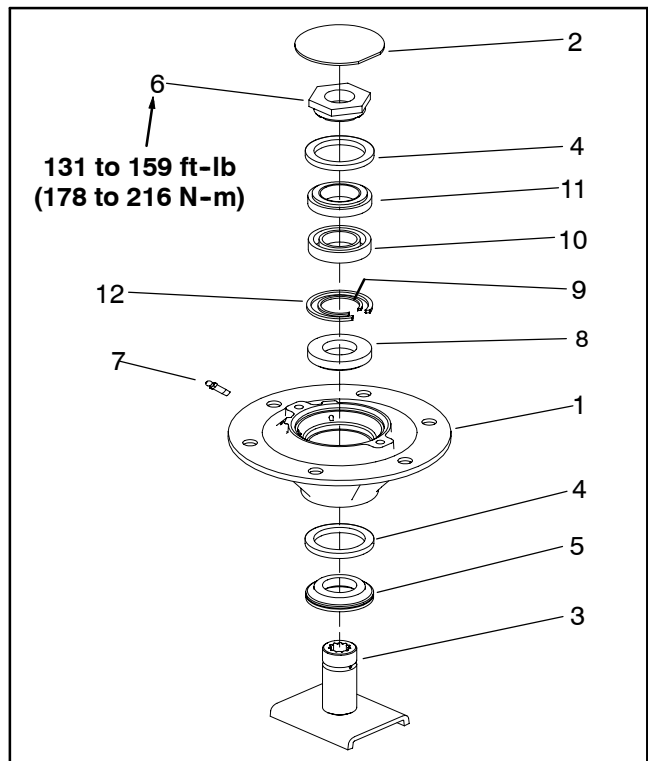

Figure 27

1. Spindle housing
2. Spindle plug
3. Spindle shaft
4. Oil seal
5. Shaft spacer
6. Spindle nut
7. Grease fitting
8. Bearing
9. Spacer ring
10. Spacer set (2 piece)
11. Bearing
12. Large snap ring

## Assembly

**IMPORTANT:** If new bearings will be installed into a used spindle housing that has the original large snap ring installed, discard the snap ring that came with the new bearings because it is not necessary to replace the original snap ring. However, new bearings with their matched spacer set and snap ring must always be installed when the spindle housing is being replaced. Replacement bearings are sold only with a matched snap ring and spacer set. These parts cannot be purchased separately.

1. If large snap ring was removed, or if replacing the spindle housing, install snap ring into spindle housing groove. Make sure snap ring is seated in groove.

**IMPORTANT:** If bearings are being replaced, make sure to use the large spacer, inside spacer, and spacer ring that are included in new bearing set.

2. Using an arbor press, push large spacer into top of spindle housing. The spacer should fit tightly against the snap ring.

3. Thoroughly oil the bearing cups. Using an arbor press, push the bearing cups into the top and bottom of the spindle housing. The top bearing cup must contact the spacer previously installed, and the bottom bearing cup must contact the snap ring. Make sure that the assembly is correct by supporting the first bearing cup and pressing the second against it (Fig 28).

4. Pack the bearing cones with grease. Apply a film of grease on lips of seals.

5. Install lower bearing and seal into bottom of spindle housing. **Note:** The bottom seal must have the lip facing out (down) (Fig. 29).

6. Slide spacer ring and inside spacer into spindle housing, then install upper bearing and seal into top of housing. **Note:** The upper seal must have the lip facing out (up) (Fig. 29).

7. Inspect the spindle shaft to make sure it is free of burrs or nicks that could possibly damage the seals. Also, make sure that lubrication hole in shaft is clean. Lubricate the shaft with grease.

8. Install spindle spacer onto shaft. Carefully slide spindle shaft through spindle housing. The bottom seal and spindle spacer fit together when the spindle is installed fully.

9. Thread spindle nut onto shaft and tighten nut from 131 to 159 ft-lb (178 to 216 N-m).

**IMPORTANT:** When greasing spindles, grease passes into the center of the shaft and out to fill the bearing cavity of the housing. If grease does not come out of lower seal when greasing, check lubrication hole in spindle shaft for obstruction.

10. Install spindle plug to top of spindle housing. Attach a hand pump grease gun to either grease fitting and fill housing cavity with grease until grease starts to come out of lower seal. **NOTE:** Pneumatic grease guns can produce air pockets when filling large cavities.

11. Install spindle housing and spindle plate to deck with cap screws and flange nuts. Notches on housing and plate should be aligned to front of deck.

12. Install cutting blade, anti-scalp cup and bolt (see Cutting Blade Removal and Installation). Tighten blade bolt from 85 to 110 ft-lb (115 to 149 N-m).

13. Position O-ring to top of spindle housing. Install hydraulic motor to the cutting unit with two cap screws.

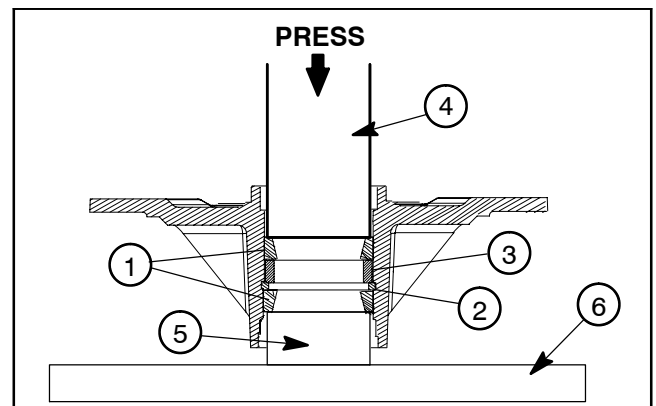

Figure 28

- |                    |                     |
|--------------------|---------------------|
| 1. Bearing cups    | 4. Arbor press      |
| 2. Large snap ring | 5. Support          |
| 3. Large spacer    | 6. Arbor press base |

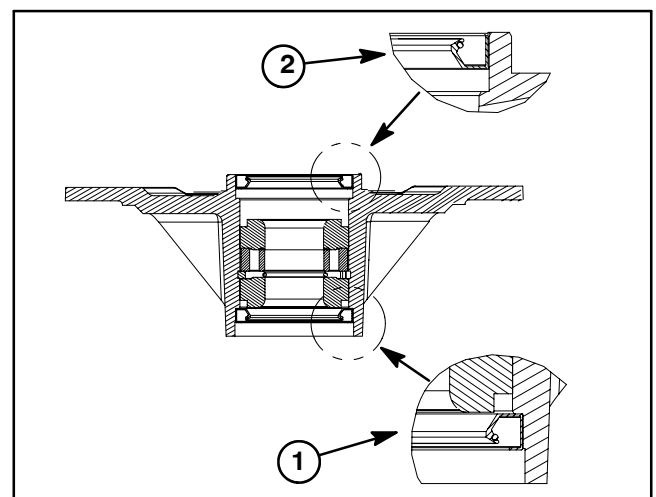

Figure 29

- |                             |                            |
|-----------------------------|----------------------------|
| 1. Bottom seal installation | 2. Upper seal installation |
|-----------------------------|----------------------------|

## Carrier Frame

The front and rear cutting units require different mounting positions on the carrier frames.

### Front Carrier Frame

1. For heights of cut in the 3/4 to 3 inch (1.9 to 7.6 cm) range, the front cutting units should be mounted in the lower front mounting holes (Fig. 30) of the carrier frame.

**NOTE:** This permits more up travel of the cutting decks relative to the tractor when approaching quick uphill changes in terrain. It does, however, limit the clearance of the cutting deck to carrier when cresting sharp knolls.

2. For heights of cut in the 2 1/2 to 4 inch (6.4 to 10.2 cm) range, the front cutting units should be mounted in the upper front mounting holes (Fig. 30) of the carrier frame.

**NOTE:** This increases the cutting deck to carrier clearance due to the higher position of the cutting deck, but will cause the cutting decks to reach their maximum up travel sooner.

### Rear Carrier Frame

1. For all heights-of-cut, the rear cutting deck should be mounted in the rear mounting holes (Fig. 30) of the carrier frame.

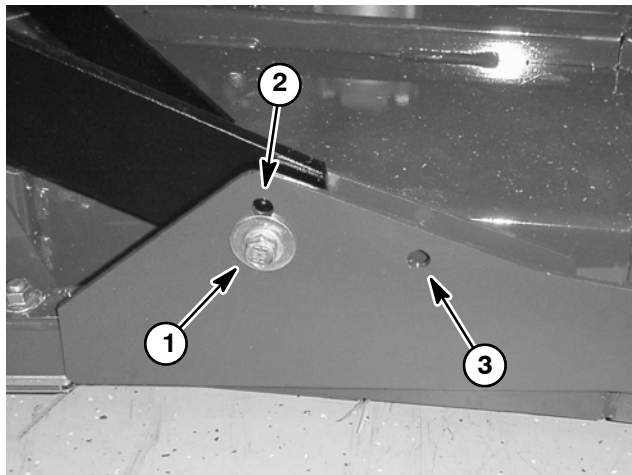

Figure 30

- 1. Lower front mtg. hole
- 2. Upper front mtg. hole
- 3. Rear mounting hole

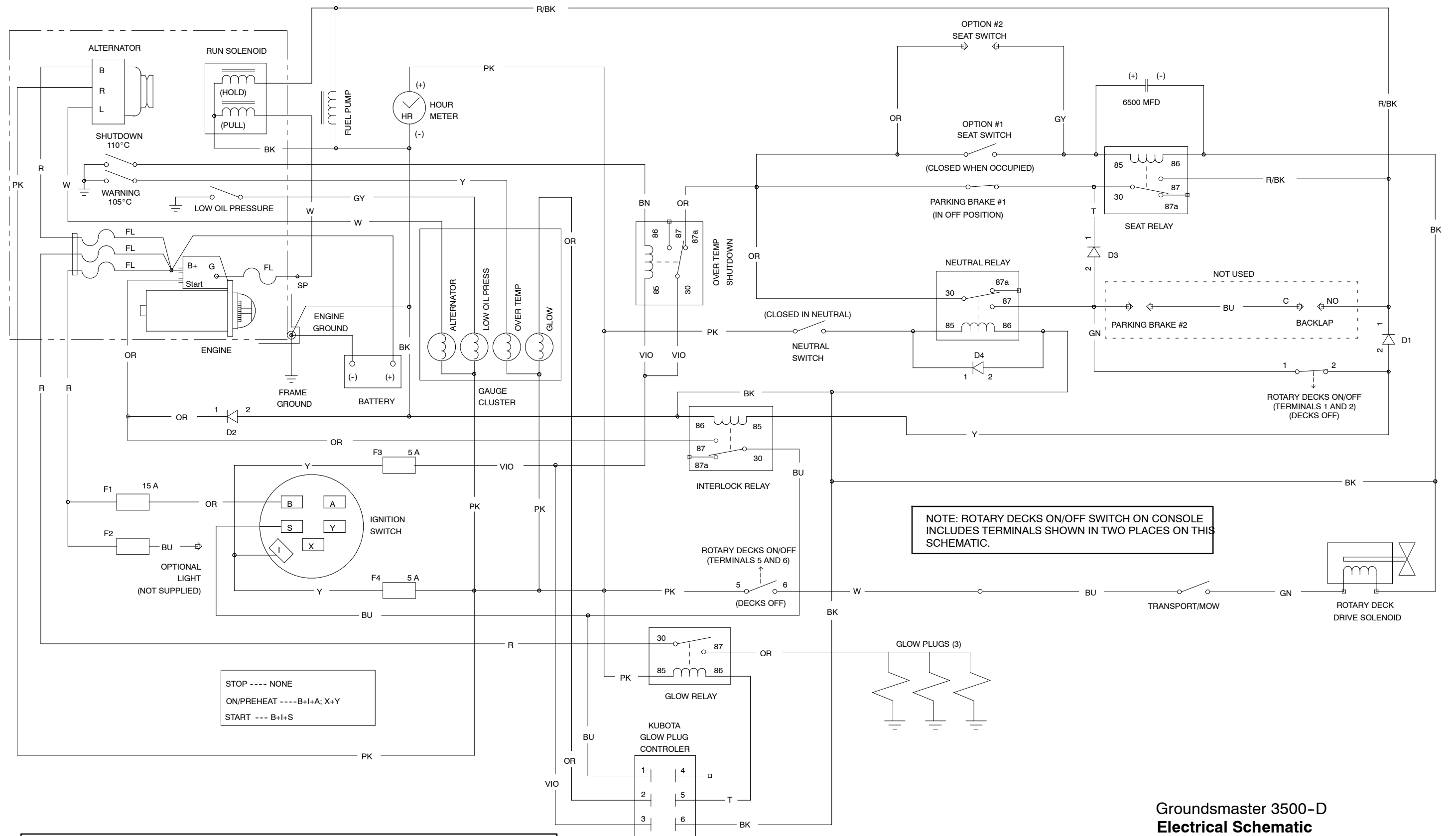

Table of Contents

ELECTRICAL SCHEMATICS AND DIAGRAMS ... 3

- Electrical Schematic (Serial Numbers 90101 to 230999999) ..... 3
- Glow Circuits ..... 4
- Crank Circuits ..... 5
- Run Circuits (Transport) ..... 6
- Run Circuits (Mow) ..... 7
- Harness Diagram (Serial Numbers 90101 to 230999999) ..... 8
- Harness Drawing (Serial Numbers 90101 to 230999999) ..... 9
- Electrical Schematic (Serial Numbers 240000001 to 314000000) ..... 10
- Electrical Schematic (Serial Numbers 314000001 to 403440000) ..... 11
- Electrical Schematic (Serial Numbers 403440001 and Up) ..... 12
- Harness Diagram (Serial Numbers 240000001 to 313999999) ..... 13
- Harness Drawing (Serial Numbers 240000001 to 313999999) ..... 14
- Harness Diagram (Serial Numbers 314000001 to 403440000) ..... 15
- Harness Drawing (Serial Numbers 314000001 to 403440000) ..... 16
- Harness Drawing (Serial Numbers 403440001 and Up) ..... 17
- Harness Drawing (Serial Numbers 403440001 and Up) ..... 18

This page is intentionally blank.



BK -- BLACK	GY -- GRAY	R -- RED
BU -- BLUE	GN -- GREEN	T -- TAN
BN -- BROWN	OR -- ORANGE	VIO - VIOLET
— FUSIBLE LINK	PK -- PINK	W -- WHITE
		Y -- YELLOW
		R/BK - RED/BLACK
		SP -- SPLICE

**Groundsmaster 3500-D  
Electrical Schematic**  
(Serial Numbers 90101 to 230999999)

All relays and solenoids are shown as de-energized.

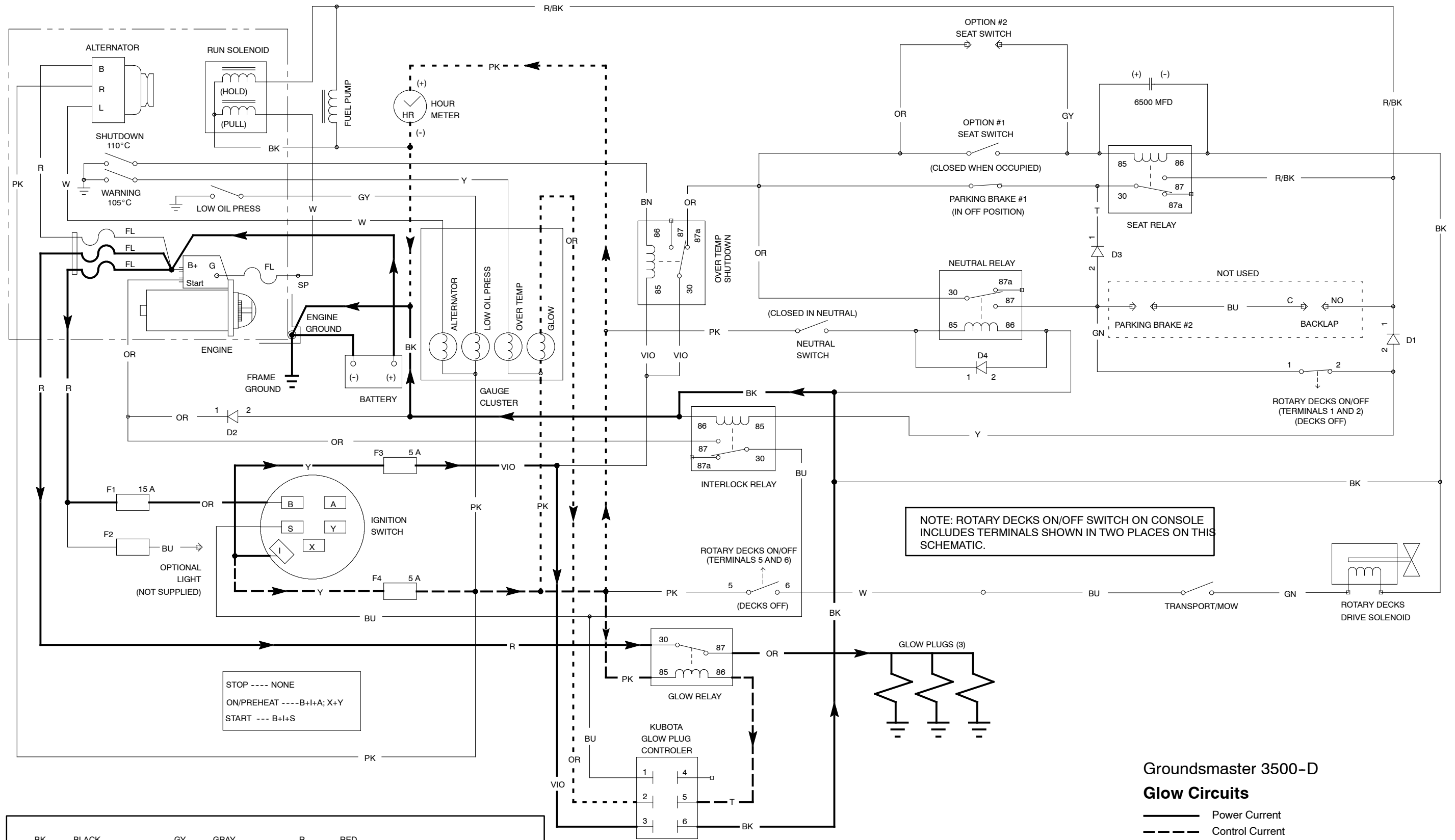

STOP ---- NONE  
 ON/PREHEAT ---- B+I+A; X+Y  
 START --- B+I+S

NOTE: ROTARY DECKS ON/OFF SWITCH ON CONSOLE INCLUDES TERMINALS SHOWN IN TWO PLACES ON THIS SCHEMATIC.

BK -- BLACK	GY -- GRAY	R -- RED
BU -- BLUE	GN -- GREEN	T -- TAN
BN -- BROWN	OR -- ORANGE	VIO - VIOLET
Y -- YELLOW	PK -- PINK	W -- WHITE
SP -- SPLICE		

**Groundsmaster 3500-D**  
**Glow Circuits**

——— Power Current  
 - - - - Control Current  
 ····· Indication Current  
 ➤ Logic Direction

(Schematic from machine with Serial Number 90101 to 230999999 shown)



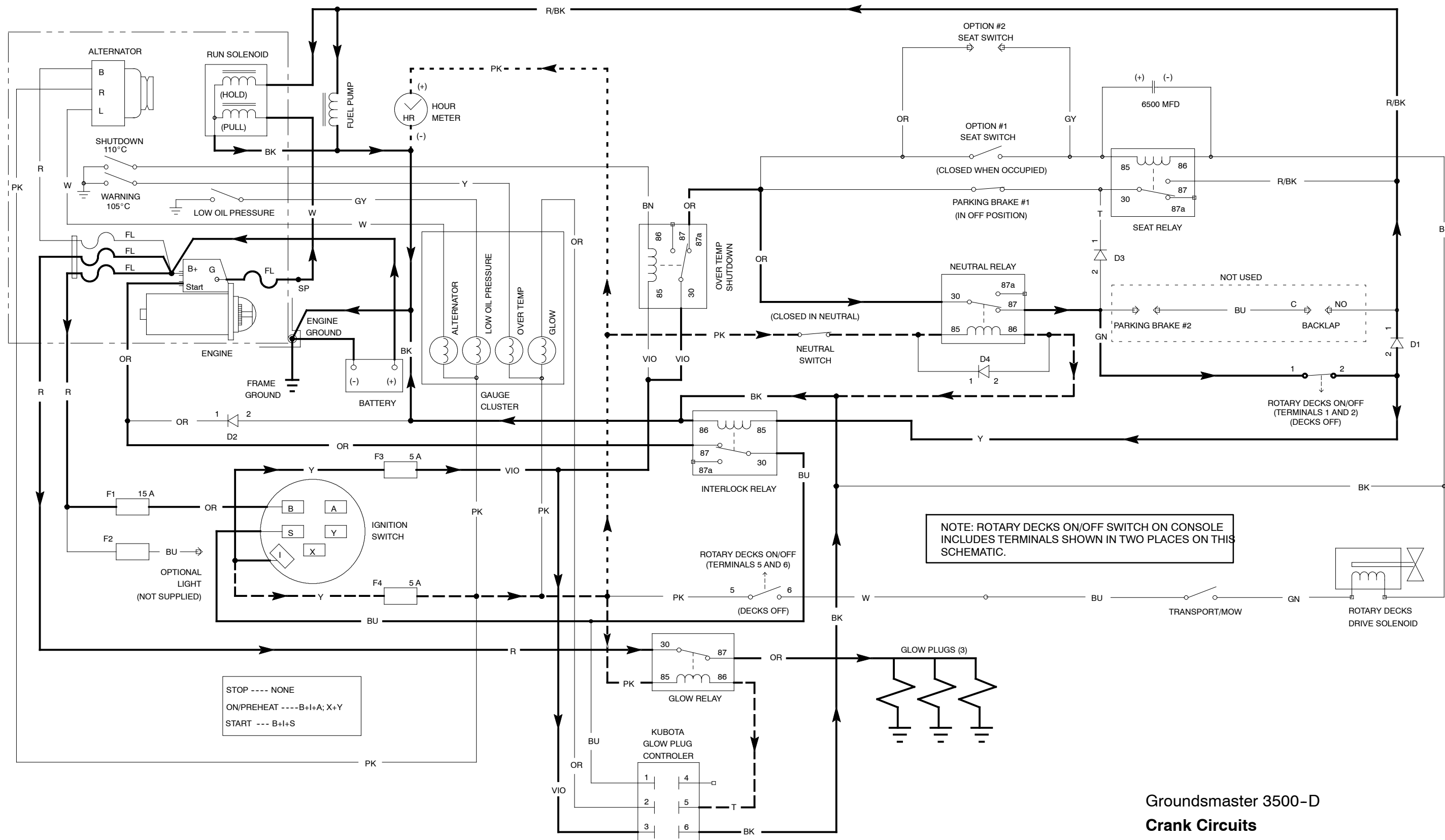

BK -- BLACK	GY -- GRAY	R -- RED
BU -- BLUE	GN -- GREEN	T -- TAN
BN -- BROWN	OR -- ORANGE	VIO - VIOLET
W -- WHITE	PK -- PINK	Y -- YELLOW
SP -- SPLICE	R/BK - RED/BLACK	

**Groundsmaster 3500-D  
Crank Circuits**

——— Power Current  
 - - - - Control Current  
 . . . . Indication Current  
 ➤ Logic Direction

(Schematic from machine with Serial Number 90101 to 230999999 shown)

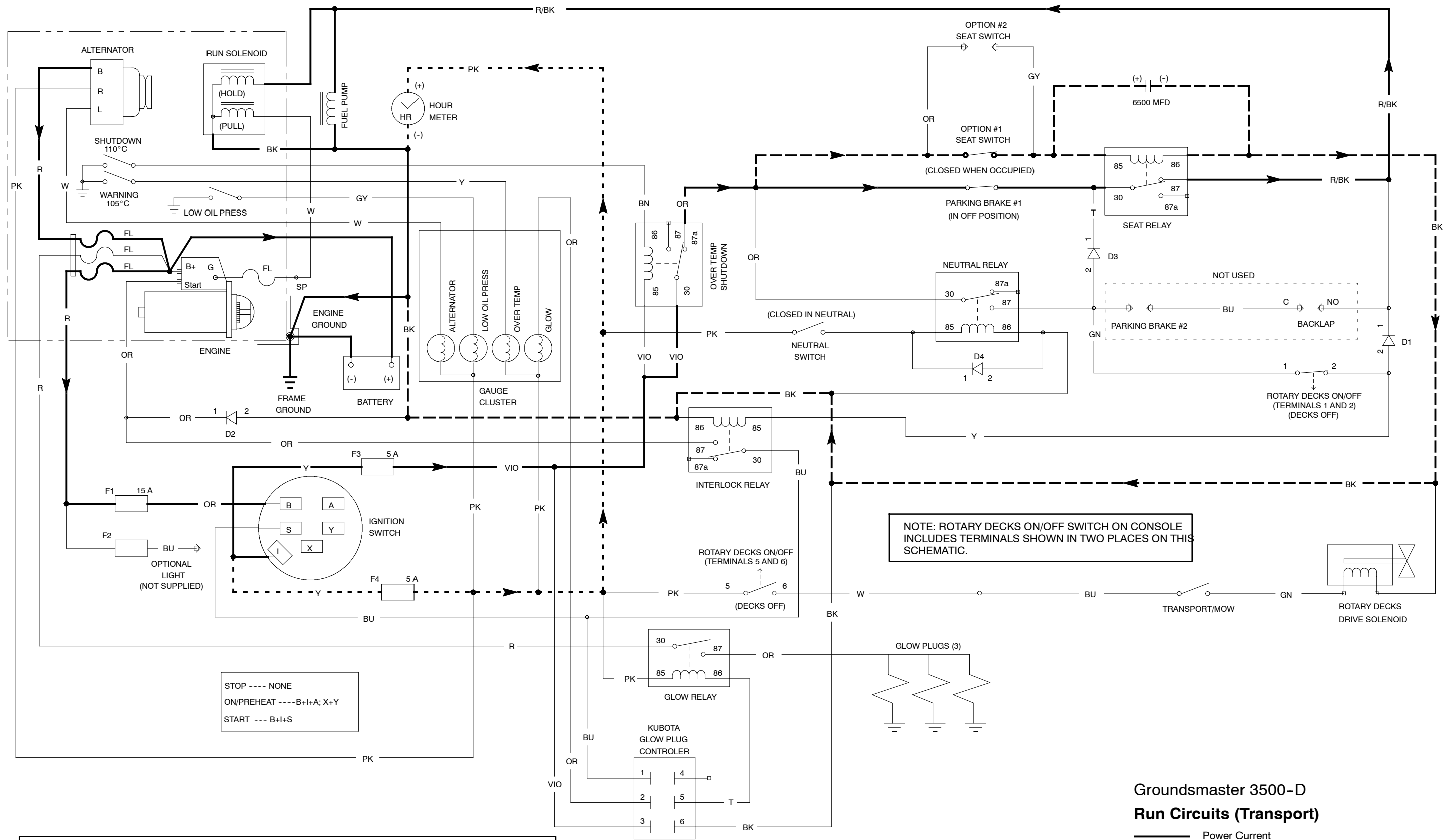

BK -- BLACK	GY -- GRAY	R -- RED
BU -- BLUE	GN -- GREEN	T -- TAN
BN -- BROWN	OR -- ORANGE	VIO - VIOLET
W -- WHITE	PK -- PINK	SP -- SPLICE
		R/BK - RED/BLACK
		Y -- YELLOW

**Groundsmaster 3500-D  
 Run Circuits (Transport)**

——— Power Current  
 - - - Control Current  
 ····· Indication Current  
 ► Logic Direction

(Schematic from machine with Serial Number 90101 to 230999999 shown)

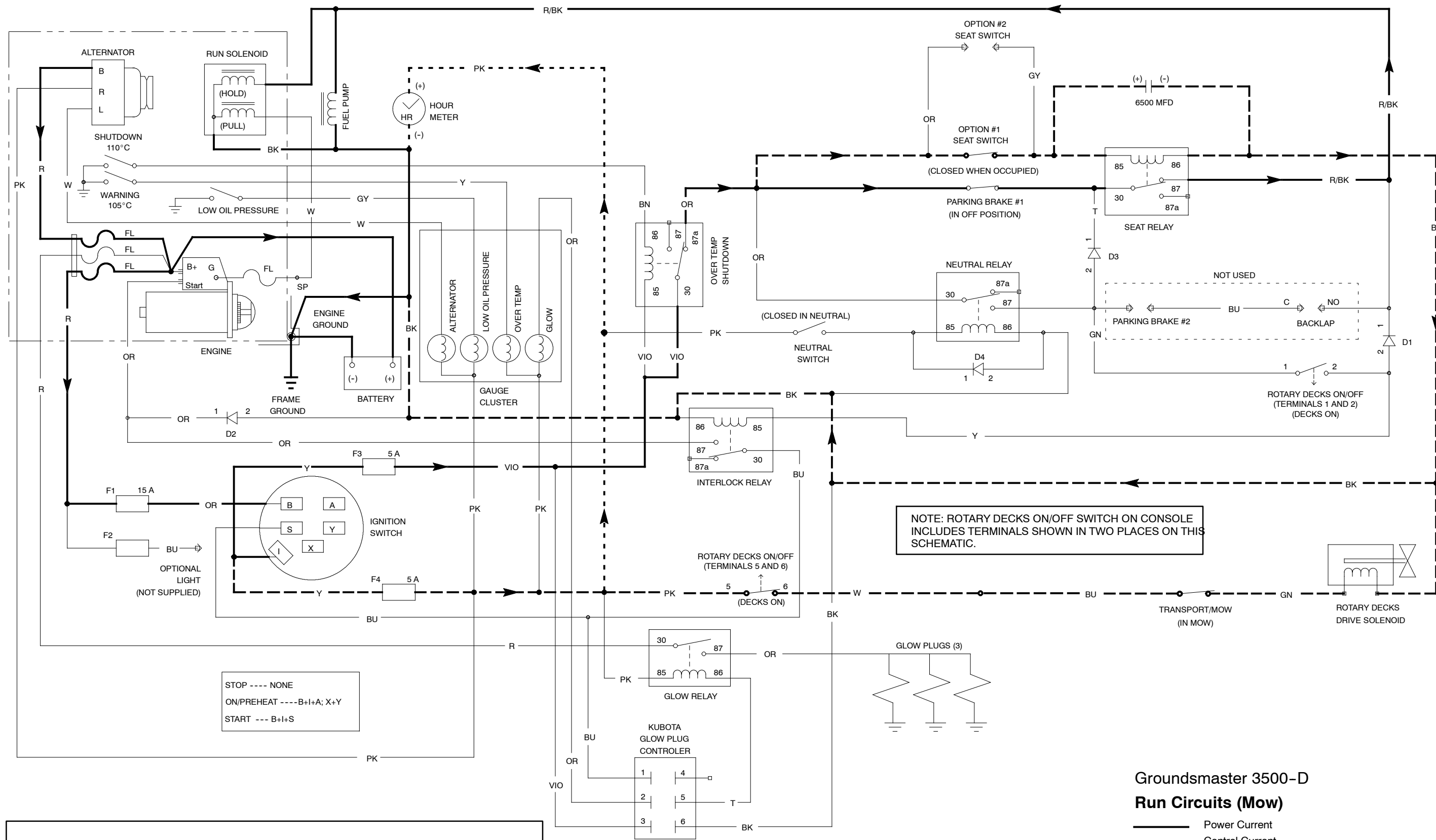

BK -- BLACK	GY -- GRAY	R -- RED
BU -- BLUE	GN -- GREEN	T -- TAN
BN -- BROWN	OR -- ORANGE	VIO - VIOLET
— FUSIBLE LINK	PK -- PINK	W -- WHITE
		SP -- SPLICE
		R/BK - RED/BLACK
		Y -- YELLOW

**Groundsmaster 3500-D**  
**Run Circuits (Mow)**

— Power Current  
 - - - Control Current  
 ····· Indication Current  
 ➤ Logic Direction

(Schematic from machine with Serial Number 90101 to 230999999 shown)

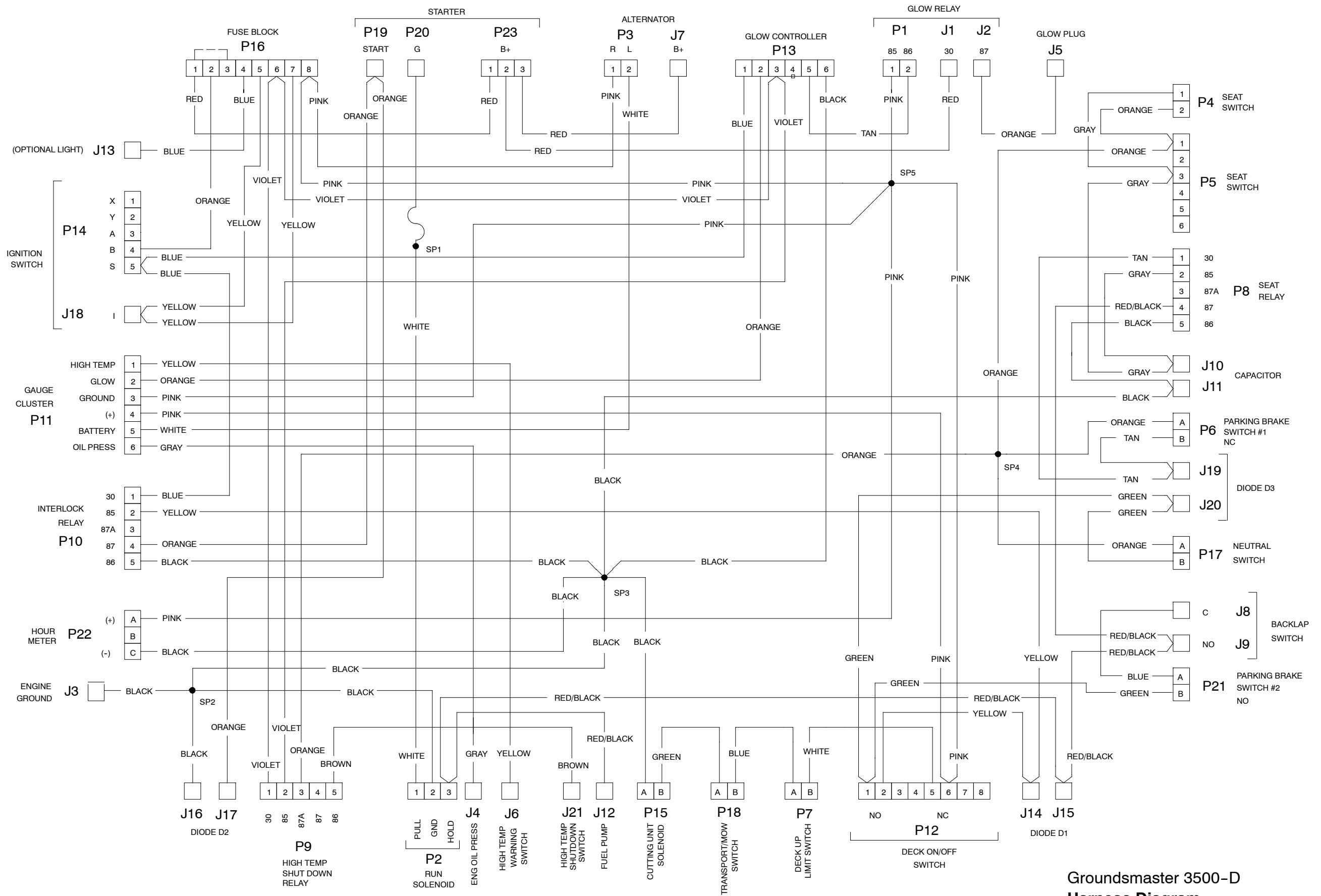

Groundsmaster 3500-D  
**Harness Diagram**  
 (Serial Numbers 90101 to 230999999)

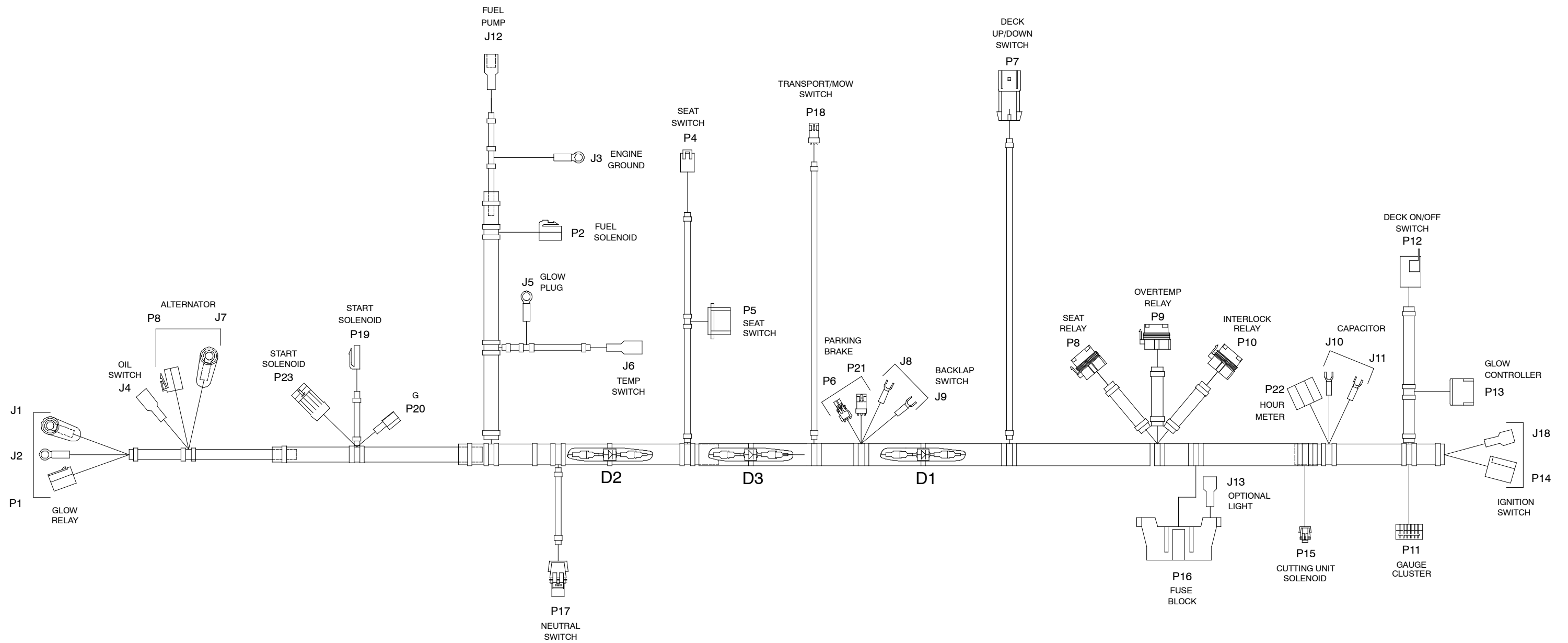

Groundsmaster 3500-D  
**Harness Drawing**  
 (Serial Numbers 90101 to 230999999)

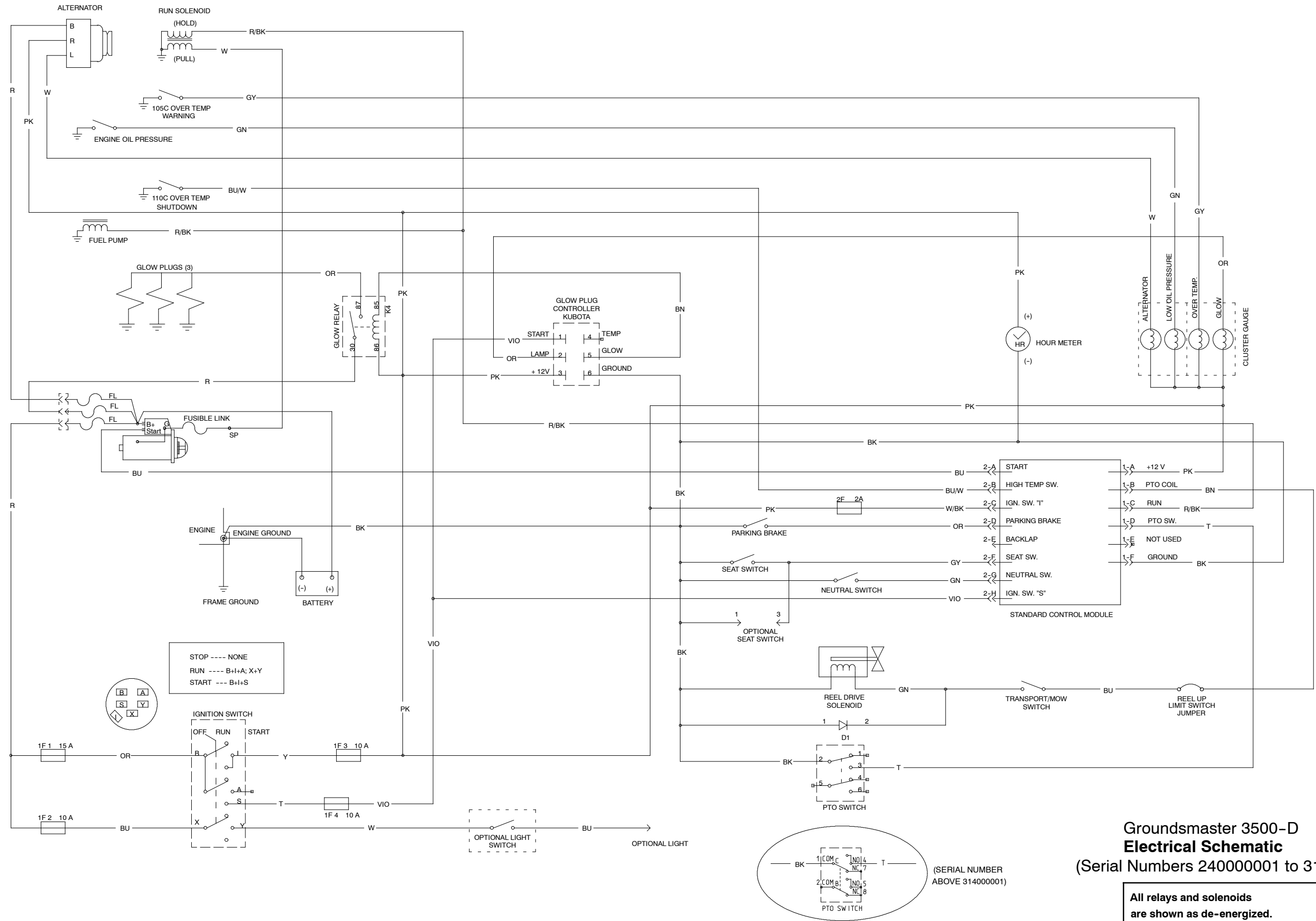

**Groundsmaster 3500-D  
Electrical Schematic**  
(Serial Numbers 240000001 to 314000000)

All relays and solenoids are shown as de-energized.

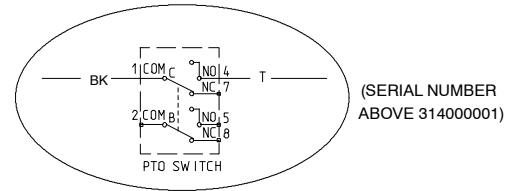

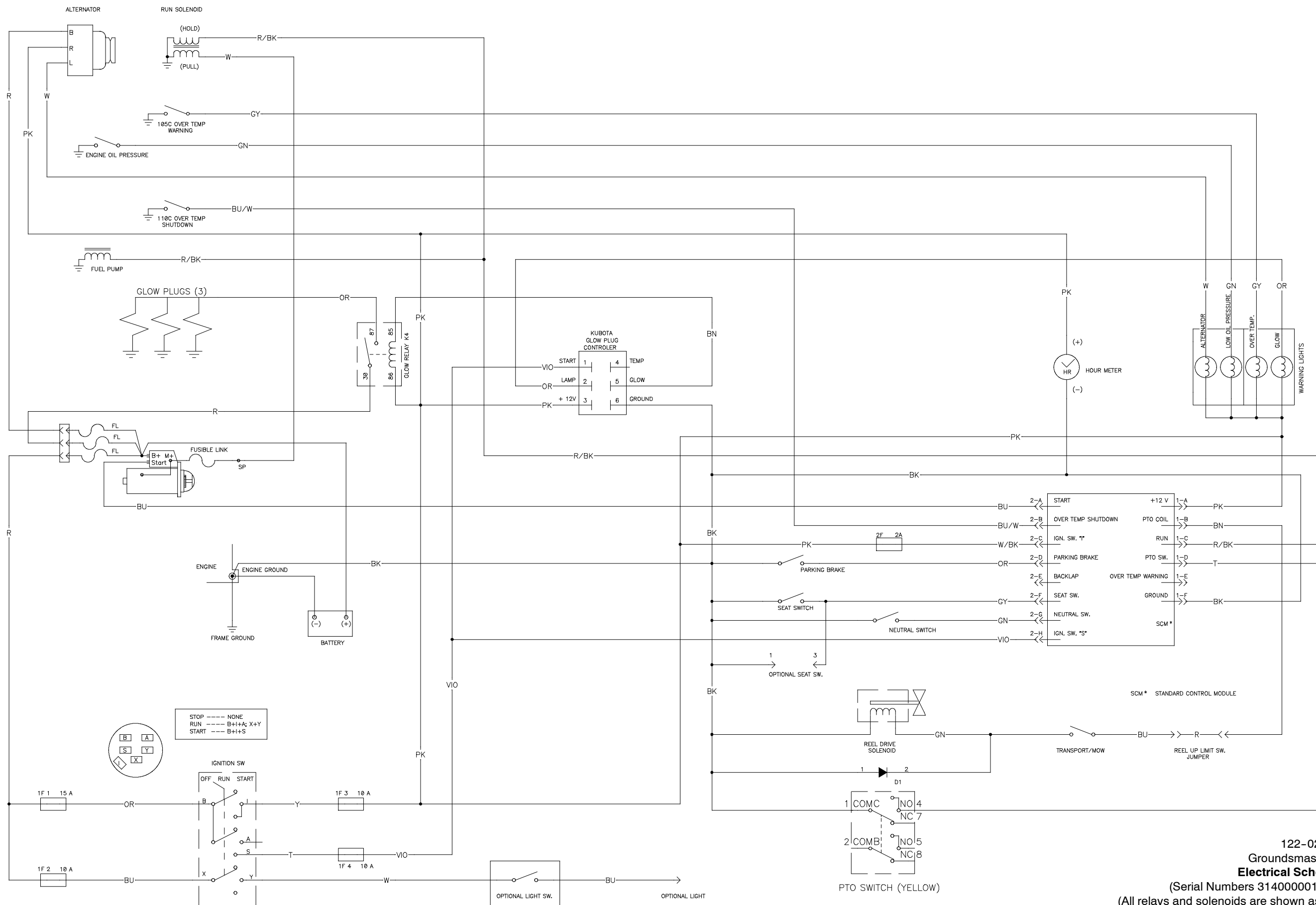

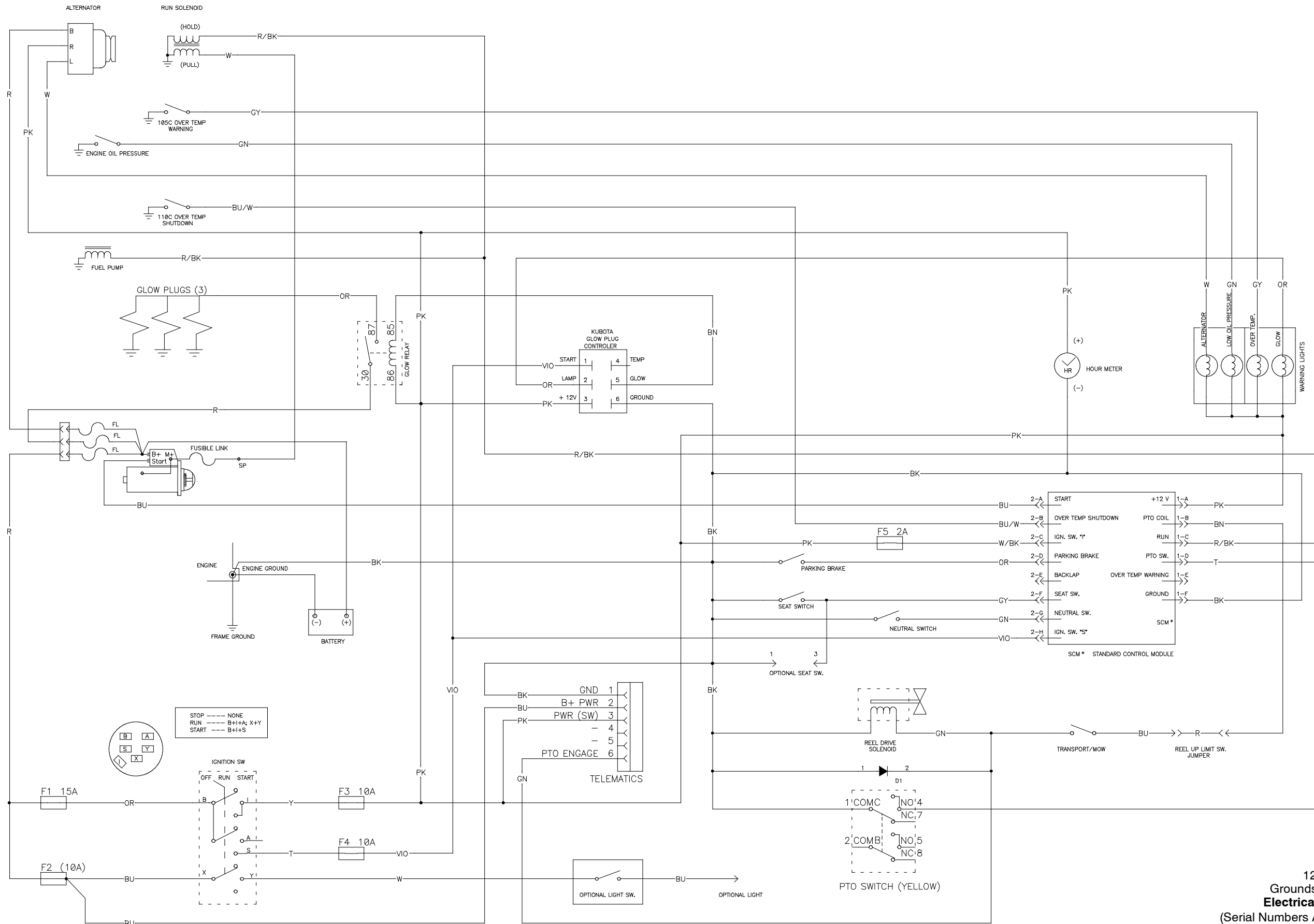

122-1521 Rev. A  
 Groundsmaster 3500-D  
**Electrical Schematic**  
 (Serial Numbers Above 403440001)  
 (All relays and solenoids are shown as de-energized)



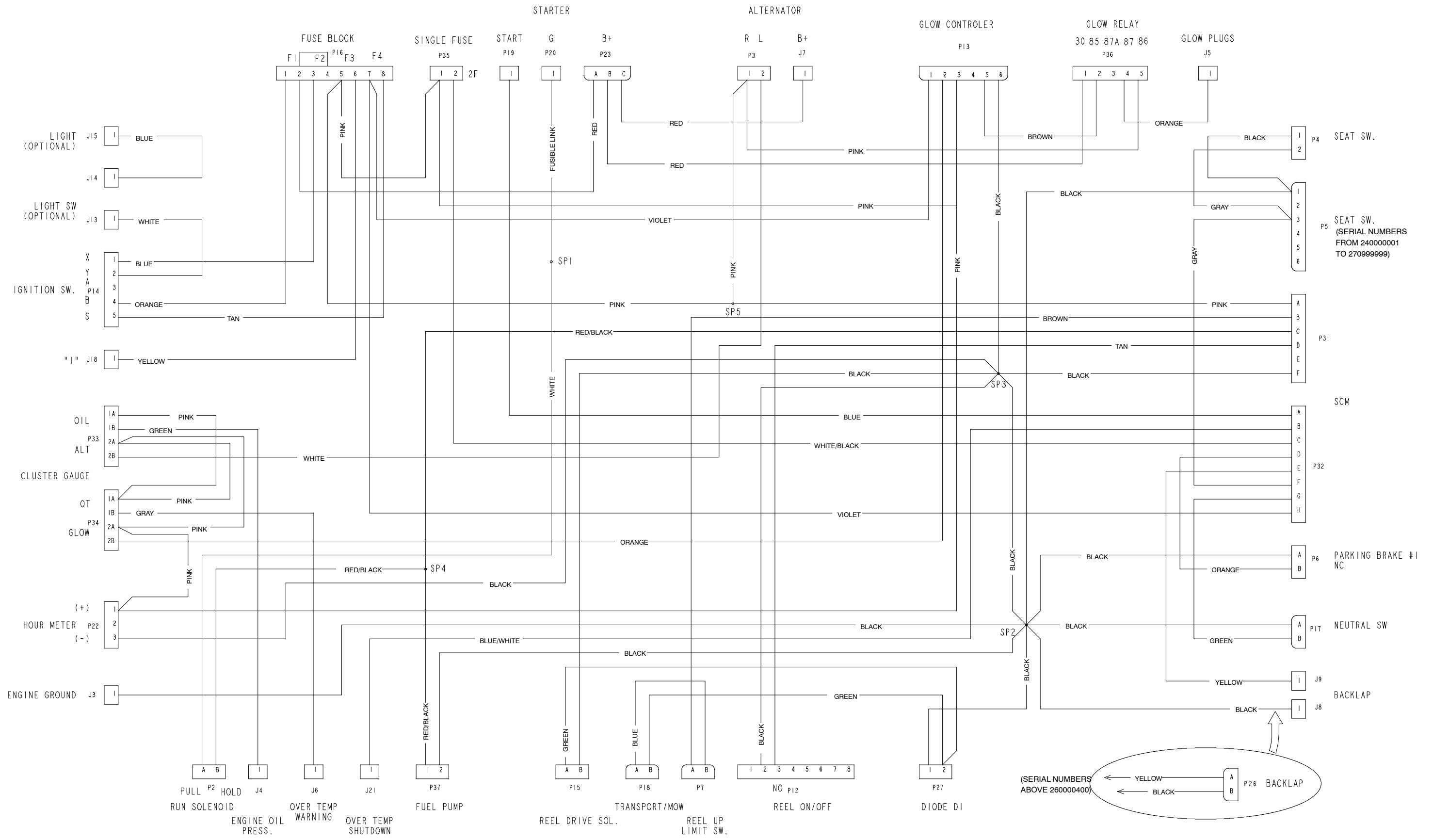

Groundsmaster 3500-D  
**Harness Diagram**  
 (Serial Numbers 240000001 to 313999999)

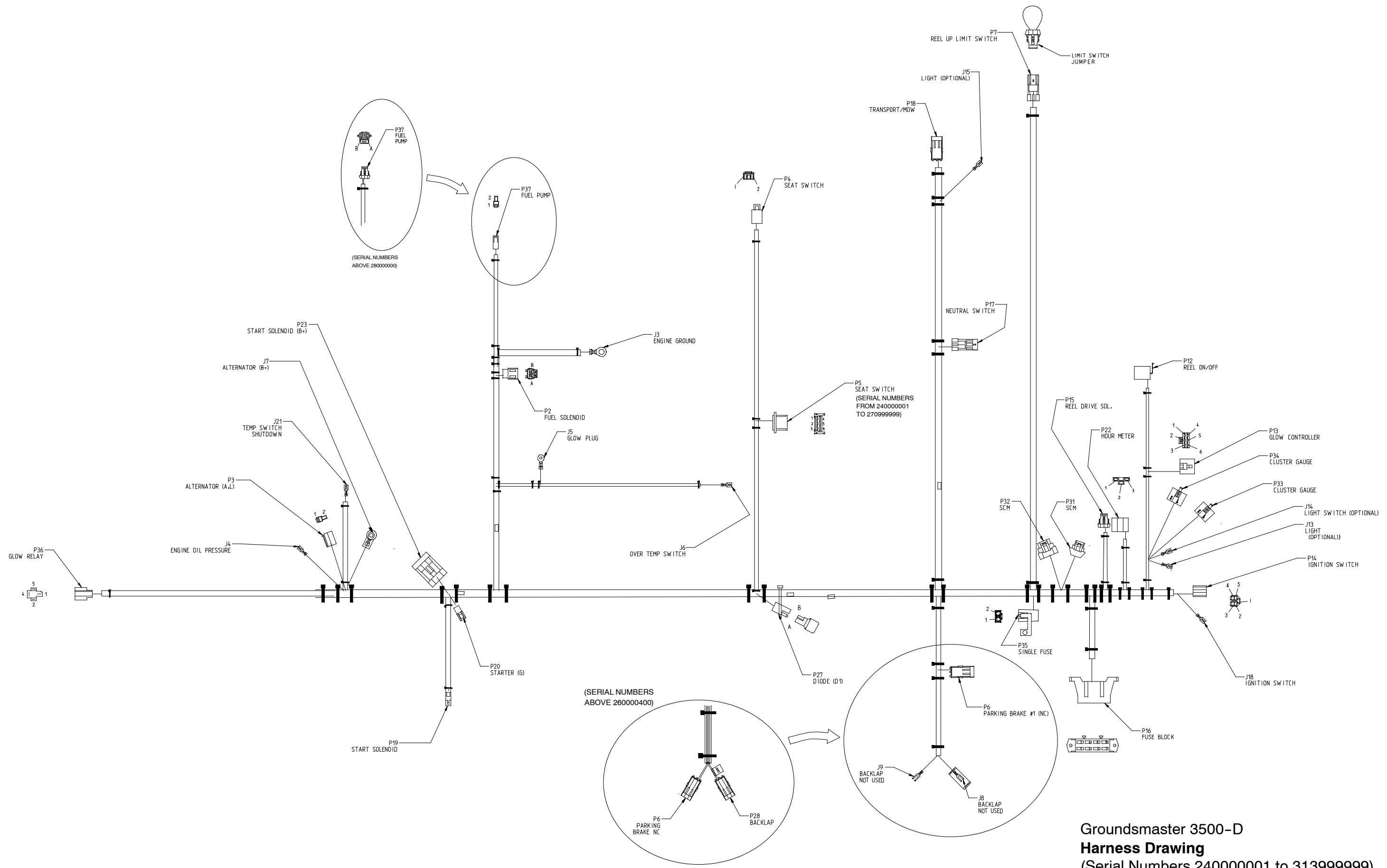

Groundsmaster 3500-D  
**Harness Drawing**  
 (Serial Numbers 240000001 to 313999999)

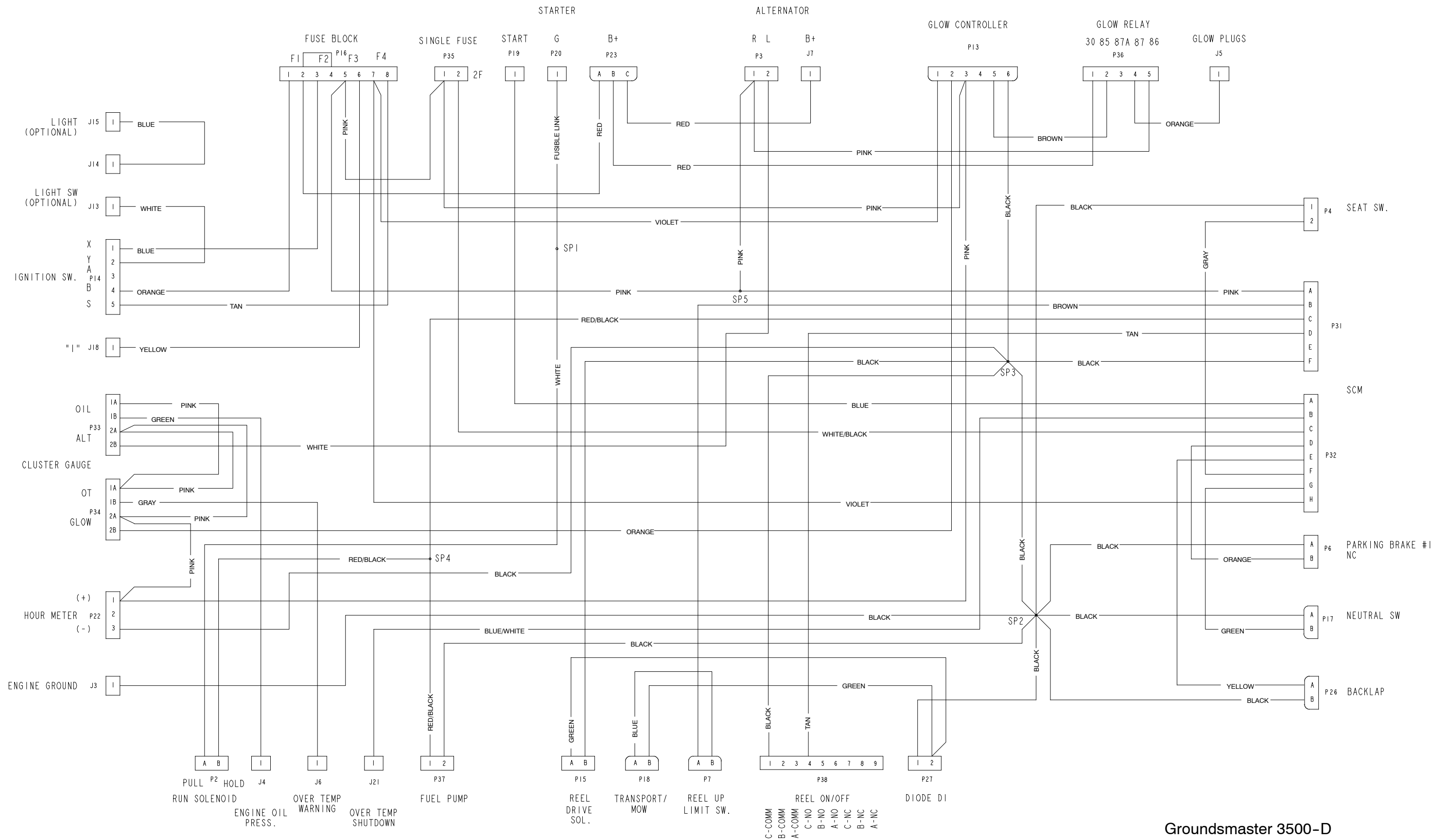

**Groundsmaster 3500-D  
Harness Diagram**  
(Serial Numbers 314000001 to 403440000)

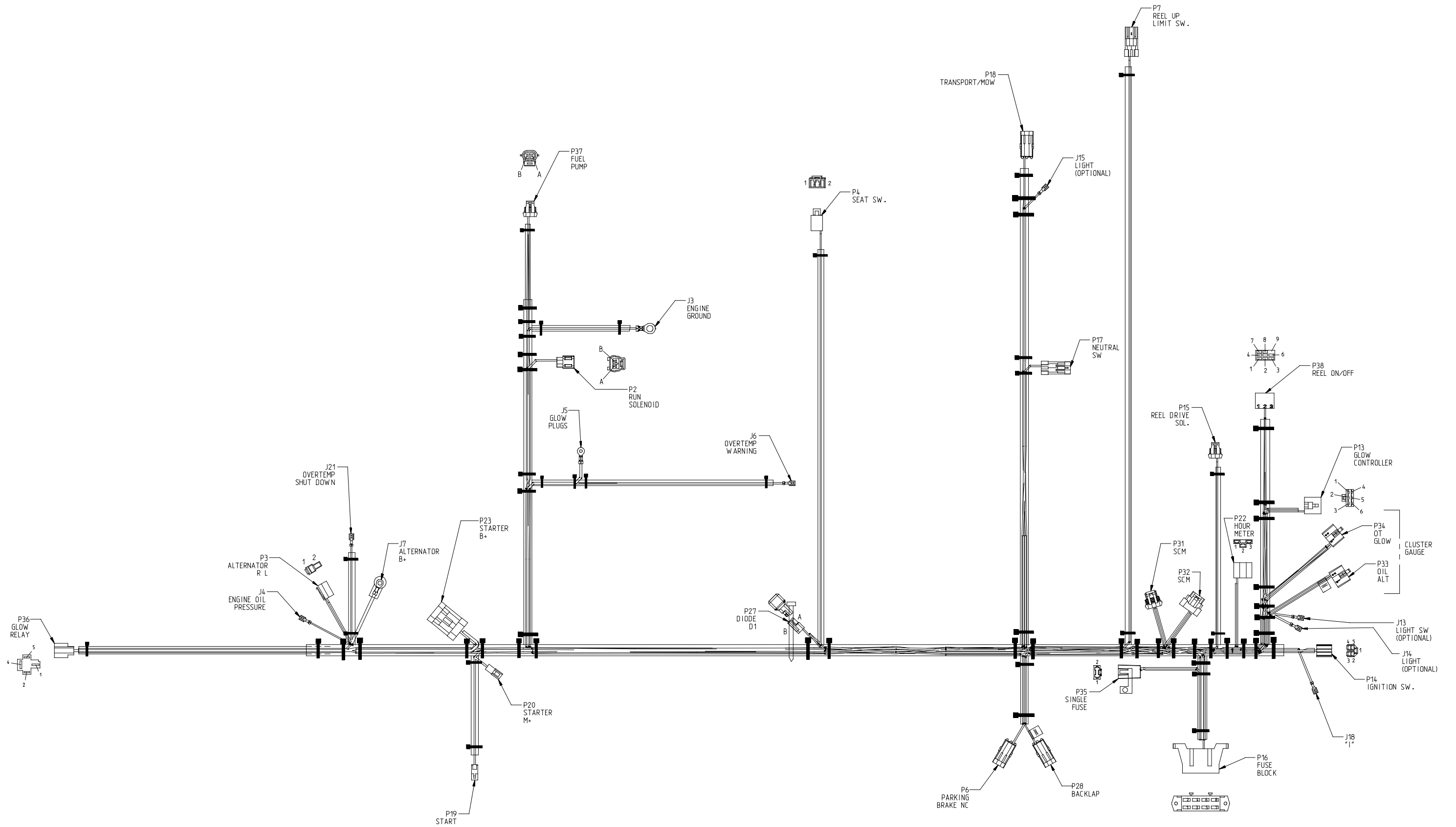

Groundmaster 3500-D  
**Harness Drawing**  
 (Serial Numbers 314000001 to 403440000)

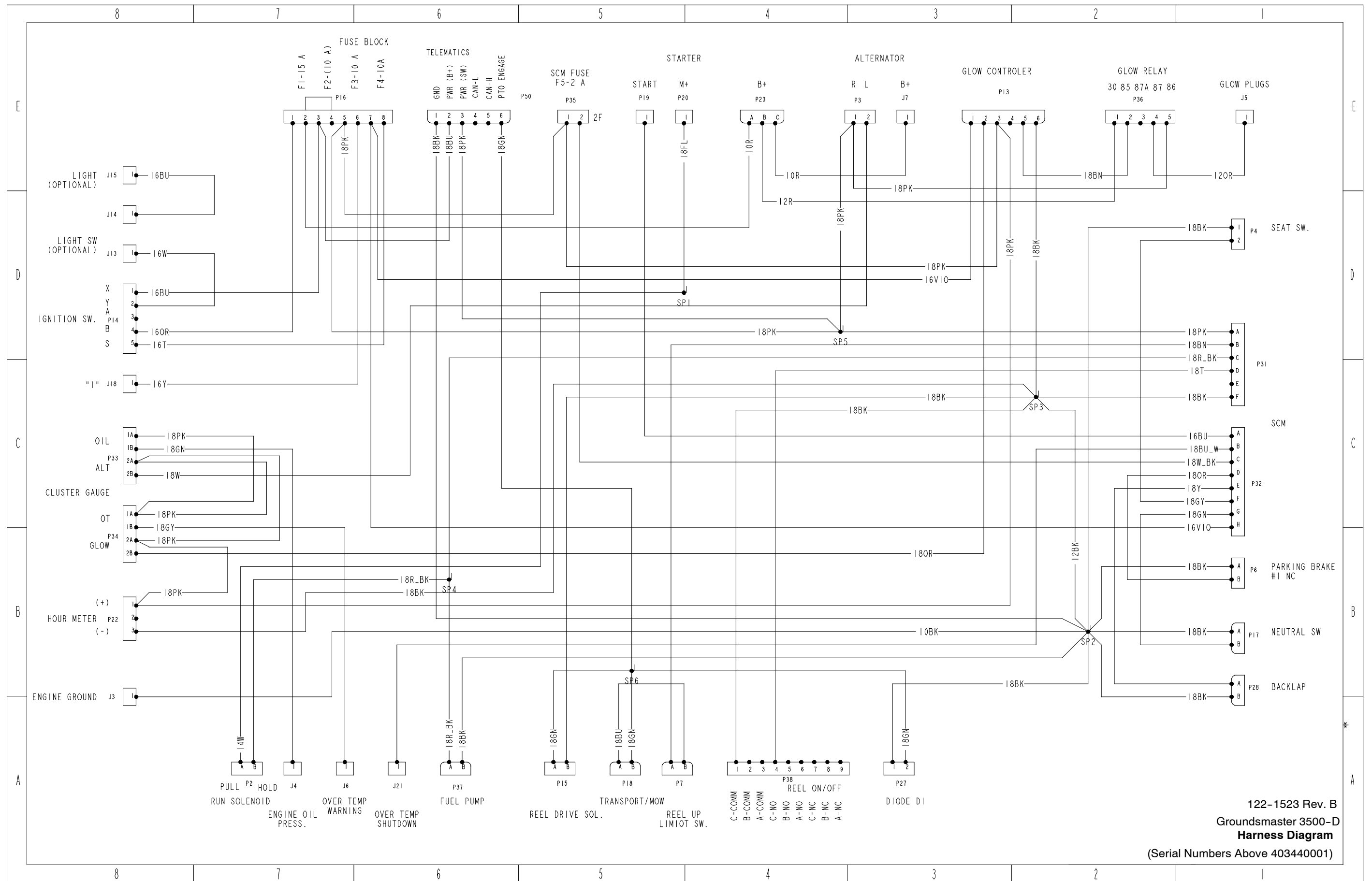

122-1523 Rev. B  
 Groundmaster 3500-D  
 Harness Diagram  
 (Serial Numbers Above 403440001)

