

AC R / AC RL

AC Servo Motors



**Product
Manual**

Additional Supporting Documentation

UL:



Planetary Gearbox PG AP

UL:



Plugs

UL:



Cables

UL:



Cable sets

©Parker Hannifin GmbH Co. KG

All rights reserved. No portion of this description may be produced or processed in any form without the consent of the company.

Changes are subject to change without notice.

Parker Hannifin has registered in part trademark protection and legal protection of designs. The handing over of the descriptions may not be construed as the transfer of any rights.

Made in Germany, 2007

Table of Contents

	Page
The Most Important Thing First	5
1 General	6
1.1 Receipt of the Materials	6
1.2 Storage.....	6
1.3 Description	6
1.4 Type Code.....	7
1.4.1 Example I.....	7
1.5 Possible options (Marking: g).....	8
1.5.1 Standard.....	8
1.5.2 Special.....	8
2 General Technical Data.....	9
3 Technical Data	10
3.1 AC <u>R</u> ; Motor size 1	10
3.2 AC <u>R</u> ; Motor size 2	11
3.3 AC <u>R</u> ; Motor size 3	12
3.3.1 AC <u>RL</u> (with separate fan); Motor size 3	13
3.4 AC <u>R</u> ; Motor size 4	14
3.4.1 AC <u>RL</u> (with separate fan); Motor size 4	15
3.5 Torque/Speed Diagrams	16
3.5.1 AC R; Motor size 1	16
3.5.2 AC R; Motor size 2	18
3.5.3 AC R; Motor size 3	20
3.5.4 AC R; Motor size 4	22
3.5.5 AC RL; Motor size 3 - 4.....	23
4 Dimensions	24
4.1 Motor size 1 – 4 <u>without</u> separate fan (AC <u>R</u>).....	24
4.2 Motor size 3 - 4 <u>with</u> separate fan (AC <u>RL</u>).....	25
5 Connector assignment.....	26
5.1 Terminal Connection	26
5.1.1 Terminal strip motor size 1 at 2.....	26
5.1.2 Terminal strip motor size 3.....	27
5.1.3 Terminal strip motor size 4.....	28
5.2 X50 - Terminal Connection	29
5.2.1 X50 – Terminal strip / motor size 1 at 2	29
5.2.2 X50 – Terminal strip / motor size 3	30
5.2.3 X50 – Terminal strip / motor size 4	31
5.3 Resolver connector	32
5.4 Fan connection motor size 2..4.....	33
5.5 Wiring Instructions.....	34
5.6 Plug designation.....	35
5.6.1 Mating plugs for motor- and brake connections.....	35
5.6.2 Mating plugs for resolver- and thermal connection.....	35
5.7 Cable designation	35
5.7.1 Motor cable	35
5.7.2 Resolver cable	35

Table of Contents

	Page
6	Holding Brake 36
6.1	Technical data of the holding brake36
7	Shaft loads 37
7.1	Representation of the definition37
7.2	Technical data of the max. radial FR [N] and axial FA [N] Shaft loads (rated speed)37
8	Nominal Power - Dependence 38
8.1	Nominal Power – Dependence upon the Installation Altitude of the Servo Motor38
9	Mounting / Installation 39
9.1	Security and Safety Instructions39
9.2	Mounting and Installation Instructions.....40
9.2.1	General Preparation.....40
9.2.2	Mechanical Installation Preparation40
9.2.3	Electrical Connections.....40
9.2.4	Rotational Direction of the Servo Motor40
10	Certifications 41
10.1	Manufacturer's Declaration41
11	Appendix 42
11.1	<u>Special</u> motor42
12	Notes 43
13	Modification Record 44



The Most Important Thing First

Thank you for your confidence in choosing our products.

These operating instructions are intended to provide an overview of the technical data and features of our products.

Please read the operating instructions completely before operating the product.

Should you have any questions, please contact your nearest service representative.

	Improper application of this product in combination with dangerous high voltage can lead to serious injury or death.
	Damage can also occur to motors or other products. Therefore, we request that you strictly observe our safety and installation instructions.

Safety Precautions

We assume that as an expert, you are familiar with and will observe all of the relevant safety regulations, especially in accordance with VDE 0100, VDE 0113, VDE 0160, EN 50178, the accident prevention regulations of the employer's liability insurance company and the DIN regulations.

Additionally, it is imperative that all relevant European Union Safety Directives be observed.

Depending on the type and location of the installation, additional regulations, e.g. UL, DIN, must also be fully observed.

If our products are operated in connection with components from other manufacturers, their operating instructions are also subject to be strictly observed.

1 General

1.1 Receipt of the Materials

All servo motors have been completely checked before shipping.

- After carefully unpacking the materials, please check to make certain that the servo motor is in good condition.
- Please do not pull on the power cord when moving the servo motor.
- Please check that the information on the product name plate matches the specifications of your order.
- In the event that the product has been damaged during transport, it is imperative that the shipping company be notified of the problem within 24 hours of receipt of the materials.

Note: The package may contain other important documentation or additional parts.

1.2 Storage

If the servo motor is not going to be placed immediately in service, then it needs to be stored in an environment which is dry and has a constant temperature in order to prevent the risk of condensation. Should the motor be placed in storage for a longer period of time, it is important to make certain that the drive shaft and the surface of the flange are completely covered by a rust-proofing agent. After storage for a longer period of time, (more than 3 months), it is important to first

operate the motor at a low speed to allow the grease to be evenly distributed within the motor.

1.3 Description

By utilizing high-energy magnetic materials it is possible to design small diameter disk motors. Due to the high-energy magnetic materials and the carefully optimized technical construction of the rotor, the motors have a low moment of inertia.

The stability of the magnetic material and the design of the magnetic field in opposition with demagnetization allow for maximum currents of up to **3- 4 times the rated current**.

This is the result of the high acceleration capacity of the low-inertia three-phase AC servo motors.

Through the permanent excitation of the magnets, no heat loss due to electrical current occurs within the rotor.

With the three-phase AC-servo motor, heat loss, due to electrical current, occurs only in the stator, which can then be directly drawn off.

These favorable cooling conditions allow for high-capacity windings.

Since all of the heat loss, due to electrical current, can be directly drawn from the surface, the motors can be designed at low cost, utilizing an enclosure type which provides protection in accordance with **IP xx**. The motors are therefore very resistant to moisture and dirt.

The resolver is built into B-side bearing bracket.

The signals for the integrated measuring system for the actual speed value, the rotor position and the indirect position are taken from the motor through a 12-pin connector.

Synchronous three-phase AC-servomotors have a number of advantages over DC motors:

- There are no electromechanical parts to wear out, and are therefore "maintenance-free".
- The low moment of inertia of the rotor, due to power density, allows for a high acceleration capacity.
- No commutation of the limit curve, providing for high acceleration moments in higher speed ranges as well.
- There are no heat losses in the rotor of the motor, providing for favorable thermal characteristics, in addition to a high degree of protection, due to the closed construction of the unit.

Three-phase AC-servomotors built in the way described, are specifically more efficient, (higher rated torque), than DC servomotors, and allow for operation at a lower moment of inertia. Therefore, the required motor size for a specific application will be smaller with a three-phase AC-servo motor than with a DC motor.

1.4 Type Code

Marking	Standard						Optional	
	a	b	c	d	e	f	g	h
Type:	AC	<u>XX</u>	XXX	-X	/X	-X	XXX	+...

Marking	Description
a	AC = Three Phase
b	Motor Types: <u>R</u> = Motor Series R <u>RL</u> = Motor Series R with separate fan
c	XXX = approx. rated torque in Ncm
d	Speed: -1 = 1000 1/min. -2 = 2000 1/min. -3 = 3000 1/min. -4 = 4000 1/min. -5 = 5000 1/min. -6 = 6000 1/min. (designation does not apply with motor / gearbox systems)
e	Motor Size /1../4 = Motor Size 1 ... 4 (designation does not apply with motor / gearbox systems)
f	-3 = 325 V DC link voltage (≅ 230 VAC supply) -6 = 565 V DC link voltage (≅ 400 VAC supply)
g	Identification for Options: XXX = see chapter " Possible options "
h	+ ... = With attached gear-box: (for short description for inserted gearbox types see gearbox documentation)

Note:

Up to marking "g" it is only necessary with options

1.4.1 Example I

A typical example of an order corresponding to the type code:

AC R 0095-6/1-3

AC	= Three Phase
<u>R</u>	= Motor Series <u>R</u>
0095	= Approx. rated torque in Ncm
-6	= 6000 1/min.
/1	= Motor Size BG1
-3	= 325 V DC link voltage (≅ 230 VAC supply)

1 General

1.5 Possible options (Marking: g)

1.5.1 Standard

Code	Options
GW0	Smooth motor shaft
BR0	Holding brake 24V DC, type: BR – “old design“
BBR	Holding brake 24V DC, type: BRR – “actual design“
BG0	Smooth motor shaft Holding brake 24V DC, type: BR
BBG	Smooth motor shaft Holding brake type BBR, 24V DC
AI0	Absolute- or incremental encoder preparation of attachment
BKH	Holding brake, 24V DC with hand lever operation

1.5.2 Special

Only on request !

Code	Options
MS0	Mech. special construction
SL0	Special varnish

		AC	
		R	RL
Degree of protection: With mounted mating connectors and built-on motor	IP44 (with separate fan)	<input type="checkbox"/>	●
	IP65	●	<input type="checkbox"/>
Magnetic material:	NdFeB	●	●
Electrical connections:	Straight flanged sockets	●	●
Thermal protection of motor:	Thermal detector PTC	●	●
Power:	In accordance with DIN VDE 0530 installation site: 1000 ASL T = 100K, Tu 40°C measured with attached cooling surface	●	●
Voltage:	325 V DC	●	●
	565 V DC	●	●
Cooling:	Self cooling	●	<input type="checkbox"/>
	Separate cooling	<input type="checkbox"/>	●
Operating mode:	Continuous operation S1	●	●
Bearings:	Ball bearings, service life approx. 15.000 h	●	●
Motor shaft: (Standard)	With key, in accordance with DIN 6885	●	●
Rotational accuracy:	N, in acc. with DIN ISO 2373	●	●
Number of pole pairs:	2 (motor size 1 - 2)	★	★
	3 (motor size 3 - 4)		
Resolver type:	2 pole standard resolver transmitter	●	●
Insulation class:	F (VDE 0530) 155° C, heating 100° K	●	●
Varnish: (standard)	Similar RAL 9005 (black)	●	●

- standard design
- not possible
- ★ dependent on size

3 Technical Data

3.1 AC R; Motor size 1

AC-Servo motor Type:	Size	power	torque	Rated -		current at		torque	Static - max. torque	current	Moment of inertia with resolver
				speed		325V DC	565V DC				
	(-)	P _N (KW)	M _N (Nm)	n _N (min ⁻¹)	I _{N325} (A)	I _{N565} (A)	M ₀ (Nm)	M _{0max} (Nm)	I ₀ (A)	J _M (kgcm ²)	
AC R 0068-2/1-6	1.1	0,14	0,68	2000	-	0,30	0,75	3,00	0,35	0,70	
AC R 0066-3/1-3		0,21	0,66	3000	0,80	-	0,75	3,00	0,90	0,70	
AC R 0060-6/1-6		0,38	0,60	6000	-	0,80	0,75	3,00	1,00	0,70	
AC R 0110-2/1-6	1.2	0,23	1,10	2000	-	0,50	1,20	4,80	0,60	1,00	
AC R 0105-3/1-6		0,33	1,05	3000	-	0,70	1,20	4,80	0,80	1,00	
AC R 0100-4/1-3		0,43	1,00	4000	1,70	-	1,20	4,80	2,00	1,00	
AC R 0100-4/1-6		0,43	1,00	4000	-	0,90	1,20	4,80	1,10	1,00	
AC R 0095-6/1-3		0,60	0,95	6000	2,40	-	1,20	4,80	3,00	1,00	
AC R 0095-6/1-6		0,60	0,95	6000	-	1,30	1,20	4,80	1,60	1,00	
AC R 0175-3/1-3		1.3	0,56	1,75	3000	2,10	-	2,00	8,00	2,40	1,35
AC R 0170-4/1-3	0,71		1,70	4000	2,80	-	2,00	8,00	3,25	1,35	
AC R 0170-4/1-6	0,71		1,70	4000	-	1,60	2,00	8,00	1,80	1,35	
AC R 0160-6/1-3	1,00		1,60	6000	3,90	-	2,00	8,00	4,90	1,35	
AC R 0160-6/1-6	1,00		1,60	6000	-	2,20	2,00	8,00	2,75	1,35	

AC-Servo motor Type:	Size	Mass	Motor-		Thermal time constant *		Torque constant	E.M.F-constant r.m.s
			resistance	induc--tance	at			
	(-)	m (kg)	Rph/ph (Ω)	Lph/ph (mH)	I _{Nenn} T _{thN} (min)	I _{max} T _{thmax} (s)	KT (Nm/A)	KE (V/1000 min. ⁻¹)
AC R 0068-2/1-6	1.1	3,30	191,40	487,20			2,27	133
AC R 0066-3/1-3		3,30	27,00	68,00			0,83	50
AC R 0060-6/1-6		3,30	6,80	17,00			0,40	25
AC R 0110-2/1-6	1.2	3,80	95,60	296,00			2,20	133
AC R 0105-3/1-6		3,80	43,40	131,40			1,50	88
AC R 0100-4/1-3		3,80	7,60	23,20			0,59	38
AC R 0100-4/1-6		3,80	24,20	74,00			1,11	67
AC R 0095-6/1-3		3,80	3,40	10,40			0,42	25
AC R 0095-6/1-6		3,80	10,80	33,20			0,73	45
AC R 0175-3/1-3		1.3	4,30	8,60	29,40			0,83
AC R 0170-4/1-3	4,30		4,80	16,60			0,61	38
AC R 0170-4/1-6	4,30		15,40	53,00			1,06	67
AC R 0160-6/1-3	4,30		2,20	7,40			0,41	25
AC R 0160-6/1-6	4,30		7,00	23,60			0,73	45

* values on request

3.2 AC R; Motor size 2

AC-Servo motor Type:	Size	power	torque	Rated - speed	current at		torque	Static - max. torque	current	Moment of inertia with resolver	
					325V DC	565V DC					
	(-)	P _N (KW)	M _N (Nm)	n _N (min ⁻¹)	I _{N325} (A)	I _{N565} (A)	M ₀ (Nm)	M _{0max} (Nm)	I ₀ (A)	J _M (kgcm ²)	
AC R 0210-2/2-3	2.1	0,44	2,10	2000	1,80	-	2,50	10,00	2,10	3,80	
AC R 0210-2/2-6		0,44	2,10	2000	-	1,00	2,50	10,00	1,10	3,80	
AC R 0205-3/2-3		0,65	2,05	3000	2,50	-	2,50	10,00	3,00	3,80	
AC R 0205-3/2-6		0,65	2,05	3000	-	1,40	2,50	10,00	1,75	3,80	
AC R 0320-2/2-3	2.2	0,68	3,20	2000	2,60	-	3,80	15,20	3,10	5,00	
AC R 0310-3/2-3		0,98	3,10	3000	3,80	-	3,80	15,20	4,65	5,00	
AC R 0310-3/2-6		0,98	3,10	3000	-	2,20	3,80	15,20	2,60	5,00	
AC R 0300-4/2-3		1,28	3,00	4000	5,00	-	3,80	15,20	6,20	5,00	
AC R 0300-4/2-6		1,28	3,00	4000	-	2,70	3,80	15,20	3,40	5,00	
AC R 0290-6/2-6		1,80	2,90	6000	-	3,90	3,80	15,20	5,15	5,00	
AC R 0510-2/2-3		2.3	1,07	5,10	2000	4,10	-	6,00	24,00	4,80	7,50
AC R 0510-2/2-6			1,07	5,10	2000	-	2,30	6,00	24,00	2,70	7,50
AC R 0500-3/2-3	1,56		5,00	3000	6,00	-	6,00	24,00	7,30	7,50	
AC R 0500-3/2-6	1,56		5,00	3000	-	3,40	6,00	24,00	4,20	7,50	
AC R 0480-4/2-3	2,00		4,80	4000	7,90	-	6,00	24,00	9,80	7,50	
AC R 0480-4/2-6	2,00		4,80	4000	-	4,40	6,00	24,00	5,50	7,50	
AC R 0450-6/2-6	2,83		4,50	6000	-	6,10	6,00	24,00	8,20	7,50	

AC-Servo motor Type:	Size	Mass	Motor-		Thermal time constant *		Torque constant	E.M.F-constant r.m.s
			resistance	inductance	at			
	(-)	m (kg)	Rph/ph (Ω)	Lph/ph (mH)	I _{Nenn} T _{thN} (min)	I _{max} T _{thmax} (s)	KT (Nm/A)	KE (V/1000 min. ⁻¹)
AC R 0210-2/2-3	2.1	6,60	9,60	45,60			1,17	74
AC R 0210-2/2-6		6,60	30,62	145,40			2,10	133
AC R 0205-3/2-3		6,60	4,20	20,00			0,82	50
AC R 0205-3/2-6		6,60	13,40	63,80			1,46	88
AC R 0320-2/2-3	2.2	7,60	5,90	32,00			1,23	74
AC R 0310-3/2-3		7,60	2,62	14,20			0,82	50
AC R 0310-3/2-6		7,60	8,36	45,20			1,40	88
AC R 0300-4/2-3		7,60	1,48	8,00			0,60	38
AC R 0300-4/2-6		7,60	4,72	25,60			1,11	67
AC R 0290-6/2-6		7,60	2,10	11,40			0,74	45
AC R 0510-2/2-3	2.3	9,40	3,04	22,80			1,24	74
AC R 0510-2/2-6		9,40	9,70	72,80			2,22	133
AC R 0500-3/2-3		9,40	1,36	10,20			0,83	50
AC R 0500-3/2-6		9,40	4,34	32,60			1,47	88
AC R 0480-4/2-3		9,40	0,76	5,80			0,60	38
AC R 0480-4/2-6		9,40	2,42	18,20			1,10	67
AC R 0450-6/2-6		9,40	1,08	8,20			0,74	45

* values on request

3 Technical Data

3.3 AC R; Motor size 3

AC-Servo motor Type:	Size	power	torque	Rated - speed	current at		torque	Static - max. torque	current	Moment of inertia with resolver
					325V DC	565V DC				
	(-)	P _N (KW)	M _N (Nm)	n _N (min ⁻¹)	I _{N325} (A)	I _{N565} (A)	M ₀ (Nm)	M _{0max} (Nm)	I ₀ (A)	J _M (kgcm ²)
AC R 0600-2/3-6	3.1	1,26	6,00	2000	-	2,80	7,50	30,00	3,45	21,30
AC R 0560-3/3-3		1,80	5,60	3000	6,90	-	7,50	30,00	9,20	21,30
AC R 0560-3/3-6		1,80	5,60	3000	-	3,80	7,50	30,00	5,10	21,30
AC R 1000-2/3-3	3.2	2,10	10,80	2000	8,50	-	12,60	50,40	10,60	32,00
AC R 1000-2/3-6		2,10	10,80	2000	-	4,70	12,60	50,40	5,90	32,00
AC R 0950-3/3-6		2,90	9,50	3000	-	6,60	12,60	50,40	8,75	32,00
AC R 0880-4/3-6		3,70	8,80	4000	-	8,30	12,60	50,40	11,90	32,00
AC R 1280-2/3-6	3.3	2,60	12,80	2000	-	6,00	16,00	64,00	7,55	48,00
AC R 1200-3/3-6		3,80	12,00	3000	-	8,30	16,00	64,00	11,10	48,00
AC R 1120-4/3-6		4,70	11,20	4000	-	10,30	16,00	64,00	14,20	48,00

AC-Servo motor Type:	Size	Mass	Motor-		Thermal time constant *		Torque constant	E.M.F-constant r.m.s
			resistance	inductance	at			
	(-)	m (kg)	Rph/ph (Ω)	Lph/ph (mH)	I _{Nenn} T _{thN} (min)	I _{max} T _{thmax} (s)	KT (Nm/A)	KE (V/1000 min. ⁻¹)
AC R 0600-2/3-6	3.1	11,50	6,26	44,64			2,14	133
AC R 0560-3/3-3		11,50	0,88	6,20			0,81	50
AC R 0560-3/3-6		11,50	2,78	19,78			1,47	88
AC R 1000-2/3-3	3.2	14,50	1,04	8,80			1,27	74
AC R 1000-2/3-6		14,50	3,32	28,06			2,30	133
AC R 0950-3/3-6		14,50	1,46	12,50			1,44	88
AC R 0880-4/3-6		14,50	0,84	7,02			1,06	67
AC R 1280-2/3-6	3.3	18,50	1,84	17,86			2,13	133
AC R 1200-3/3-6		18,50	0,82	7,98			1,45	88
AC R 1120-4/3-6		18,50	0,46	4,46			1,09	67

* values on request

3.3.1 AC RL (with separate fan); Motor size 3

AC-Servo motor Type:	Size	power	torque	Rated - speed	current at		torque	Static - max. torque	current	Moment of inertia with resolver
					325V DC	565V DC				
	(-)	P _N (KW)	M _N (Nm)	n _N (min ⁻¹)	I _{N325} (A)	I _{N565} (A)	M ₀ (Nm)	M _{0max} (Nm)	I ₀ (A)	J _M (kgcm ²)
AC RL1250-4/3-6	3.2	5,20	12,50	4000	-	11,00	17,50	50,40	15,80	32,00
AC RL1850-2/3-6	3.3	3,90	18,50	2000	-	8,20	22,50	64,00	9,90	48,00
AC RL1700-3/3-6		5,30	17,00	3000	-	11,20	22,50	64,00	14,80	48,00
AC RL1600-4/3-6		6,70	16,00	4000	-	13,80	22,50	64,00	19,80	48,00

AC-Servo motor Type:	Size	Mass	Motor-		Thermal time constant *		Torque constant	E.M.F-constant r.m.s
			resis-	induc--	at			
			tance	tance	I _{Nenn}	I _{max}		
	(-)	m (kg)	Rph/ph (Ω)	Lph/ph (mH)	T _{thN} (min)	T _{thmax} (s)	KT (Nm/A)	KE (V/1000 min. ⁻¹)
AC RL1250-4/3-6	3.2	16,00	0,84	7,02			1,14	67
AC RL1850-2/3-6	3.3	20,00	1,84	17,86			2,25	133
AC RL1700-3/3-6		20,00	0,82	7,98			1,52	88
AC RL1600-4/3-6		20,00	0,46	4,46			1,16	67

* values on request

3 Technical Data

3.4 AC R; Motor size 4

AC-Servo motor Type:	Size	power	torque	Rated - speed	current at		torque	Static - max. torque	current	Moment of inertia with resolver
					325V DC	565V DC				
	(-)	P _N (KW)	M _N (Nm)	n _N (min ⁻¹)	I _{N325} (A)	I _{N565} (A)	M ₀ (Nm)	M _{0max} (Nm)	I ₀ (A)	J _M (kgcm ²)
AC R 1750-1/4-6	4.1	1,80	17,50	1000	-	4,00	25,00	100,00	5,70	100,00
AC R 1500-2/4-6		3,10	15,00	2000	-	6,90	25,00	100,00	11,50	100,00
AC R 1250-3/4-6		3,90	12,50	3000	-	8,70	25,00	100,00	17,40	100,00
AC R 2800-1/4-6	4.2	2,90	28,00	1000	-	6,50	40,00	160,00	9,20	150,00
AC R 2400-2/4-6		5,00	24,00	2000	-	11,10	40,00	160,00	18,40	150,00
AC R 2000-3/4-3		6,30	20,00	3000	24,90	-	40,00	160,00	49,85	150,00
AC R 2000-3/4-6		6,30	20,00	3000	-	13,90	40,00	160,00	27,80	150,00
AC R 3800-2/4-6	4.3	8,00	37,80	2000	-	16,50	63,00	252,00	29,00	230,00
AC R 3150-3/4-6		10,00	31,50	3000	-	21,90	63,00	252,00	43,80	230,00

AC-Servo motor Type:	Size	Mass	Motor-		Thermal time constant *		Torque constant	E.M.F-constant r.m.s
			resis- tance	induc- tance	at			
	(-)	m (kg)	Rph/ph (Ω)	Lph/ph (mH)	I _{Nenn} T _{thN} (min)	I _{max} T _{thmax} (s)	KT (Nm/A)	KE (V/1000 min. ⁻¹)
AC R 1750-1/4-6	4.1	26,00	6,26	56,12			4,38	265
AC R 1500-2/4-6		26,00	1,56	14,04			2,17	133
AC R 1250-3/4-6		26,00	0,7	6,38			1,44	88
AC R 2800-1/4-6	4.2	32,00	3,32	35,72			4,30	265
AC R 2400-2/4-6		32,00	0,84	8,92			2,16	133
AC R 2000-3/4-3		32,00	0,12	1,24			0,80	50
AC R 2000-3/4-6		32,00	0,38	3,96			1,44	88
AC R 3800-2/4-6	4.3	43,50	0,44	6,40			2,17	141
AC R 3150-3/4-6		43,50	0,20	2,56			1,44	88

* values on request

3.4.1 AC RL (with separate fan); Motor size 4

AC-Servo motor Type:	Size	power	torque	Rated - speed	current at		torque	Static - max. torque	current	Moment of inertia with resolver
					325V DC	565V DC				
	(-)	P _N (KW)	M _N (Nm)	n _N (min ⁻¹)	I _{N325} (A)	I _{N565} (A)	M ₀ (Nm)	M _{0max} (Nm)	I ₀ (A)	J _M (kgcm ²)
AC RL3900-1/4-6	4.2	4,10	39,00	1000	-	8,60	56,00	160,00	12,40	150,00
AC RL3400-2/4-6		7,10	34,00	2000	-	14,70	56,00	160,00	24,70	150,00
AC RL2800-3/4-3		8,80	28,00	3000	35,00	-	56,00	160,00	70,70	150,00
AC RL2800-3/4-6		8,80	28,00	3000	-	18,50	56,00	160,00	37,10	150,00
AC RL6200-1/4-6	4.3	6,50	62,00	1000	-	13,50	88,00	252,00	19,80	230,00
AC RL5300-2/4-6		11,00	53,00	2000	-	23,10	88,00	252,00	38,90	230,00
AC RL4400-3/4-6		13,80	44,00	3000	-	29,40	88,00	252,00	58,70	230,00

AC-Servo motor Type:	Size	Mass	Motor-		Thermal time constant *		Torque constant	E.M.F-constant r.m.s
			resis-	induc-	at			
			tance	tance	I _{Nenn}	I _{max}		
	(-)	m (kg)	Rph/ph (Ω)	Lph/ph (mH)	T _{thN} (min)	T _{thmax} (s)	KT (Nm/A)	KE (V/1000 min. ⁻¹)
AC RL3900-1/4-6	4.2	34,00	3,32	35,72			4,53	265
AC RL3400-2/4-6		34,00	0,84	8,92			2,31	133
AC RL2800-3/4-3		34,00	0,12	1,24			0,80	50
AC RL2800-3/4-6		34,00	0,38	3,96			1,51	88
AC RL6200-1/4-6	4.3	45,50	1,78	22,96			4,59	265
AC RL5300-2/4-6		45,50	0,44	5,74			2,29	133
AC RL4400-3/4-6		45,50	0,2	2,56			1,50	88

* values on request

3 Technical Data

3.5 Torque/Speed Diagrams

3.5.1 AC R; Motor size 1

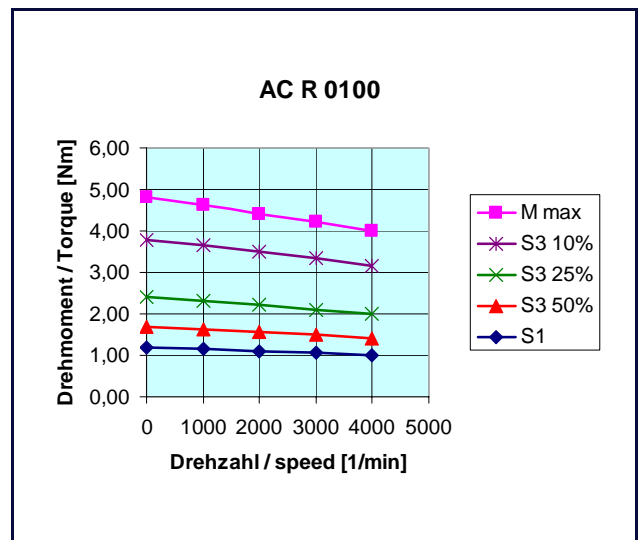
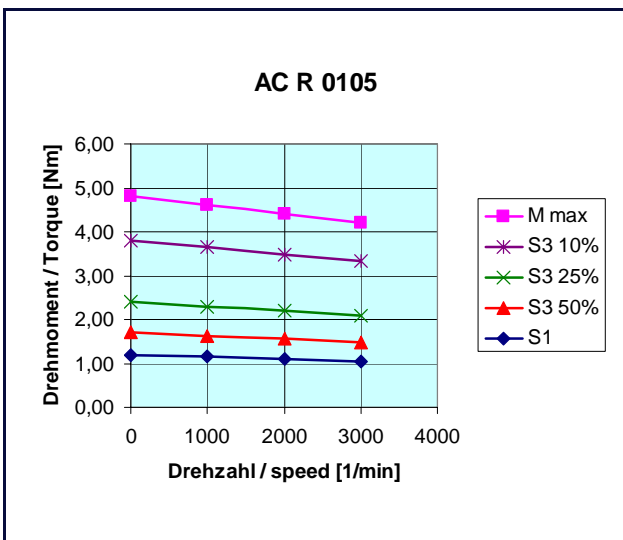
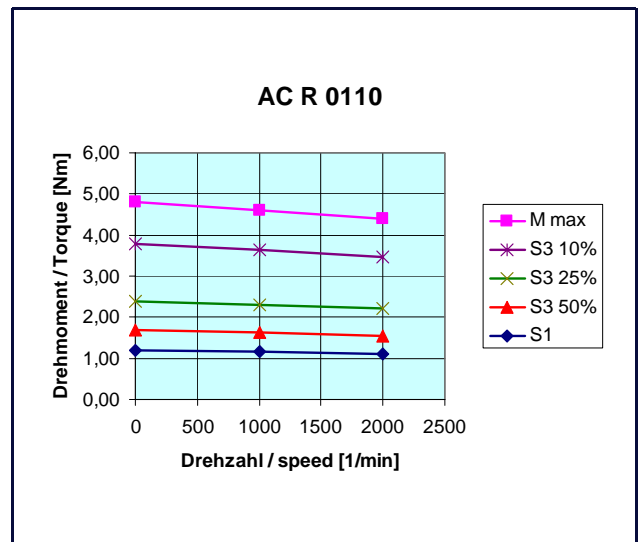
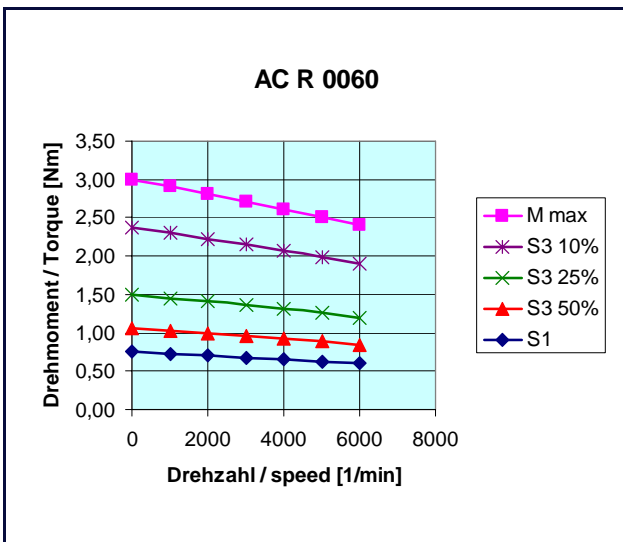
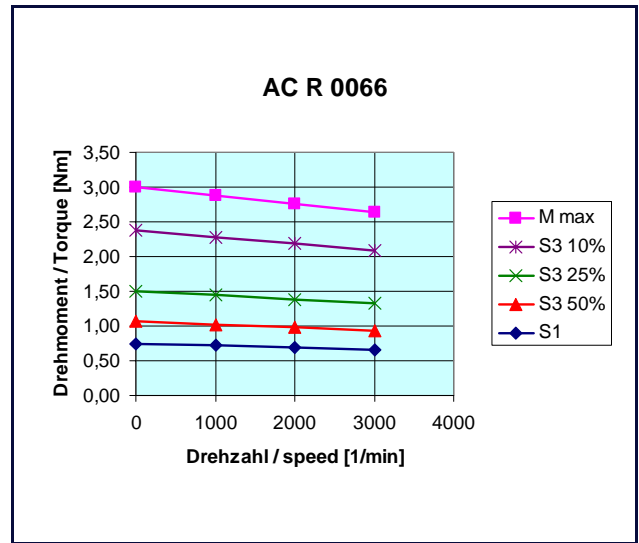
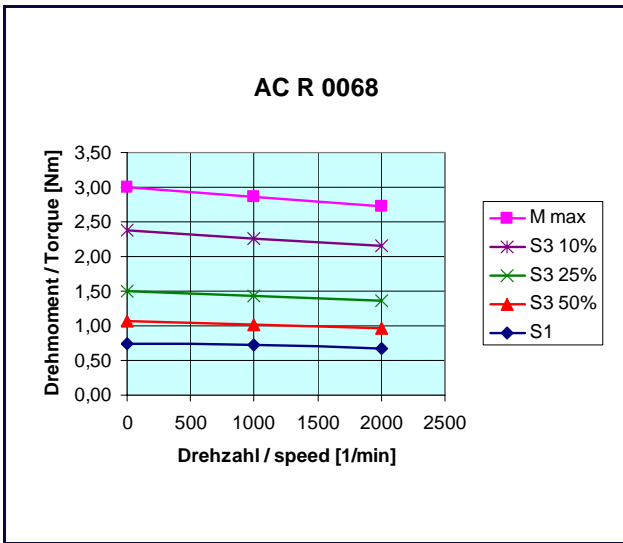

AC R; Motor size 1

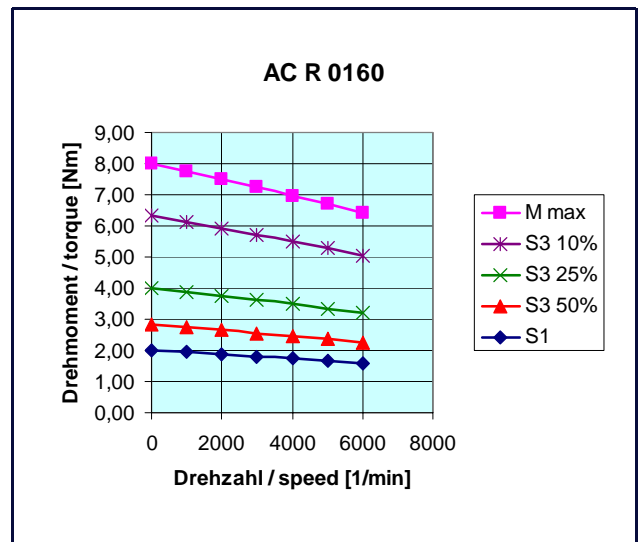
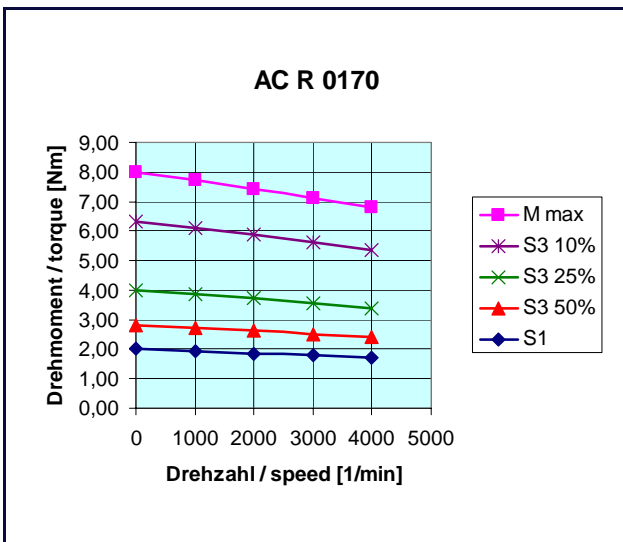
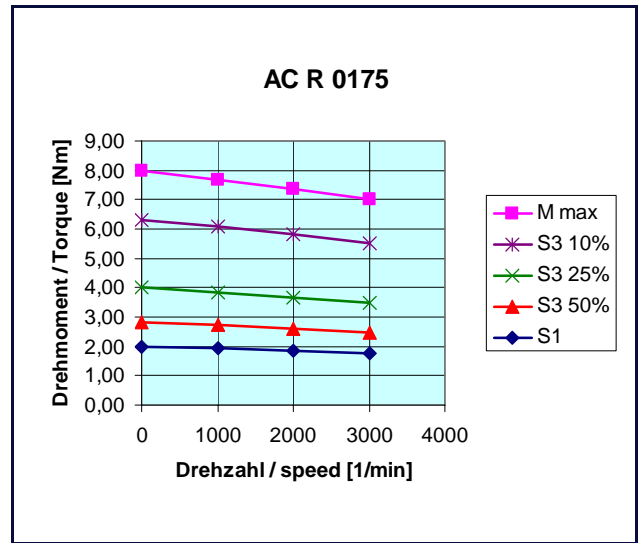
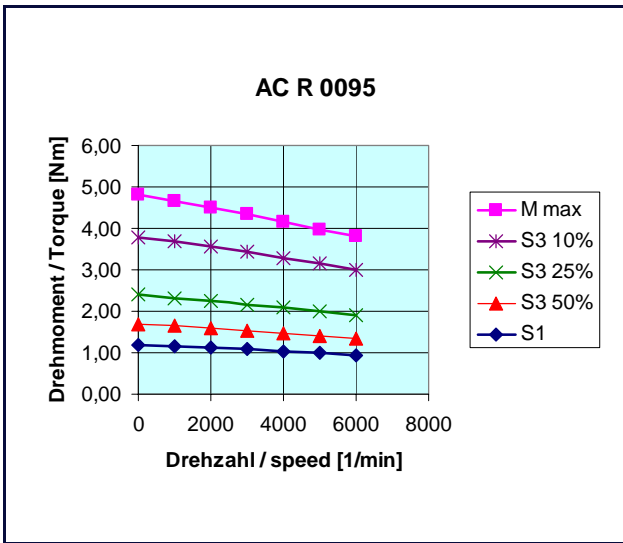

3 Technical Data

3.5.2 AC R; Motor size 2

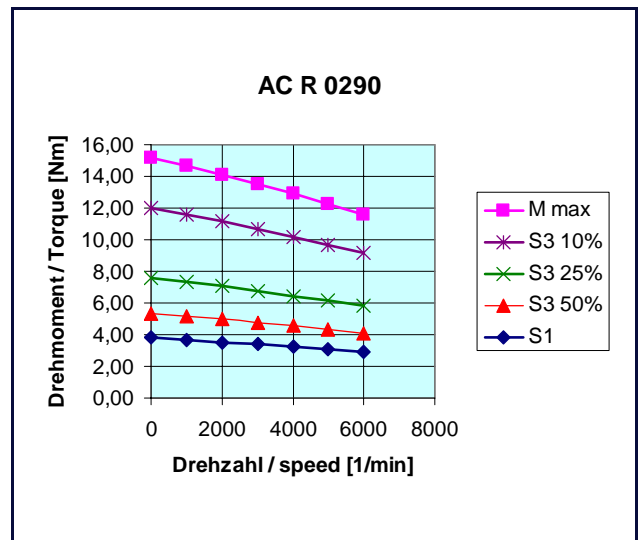
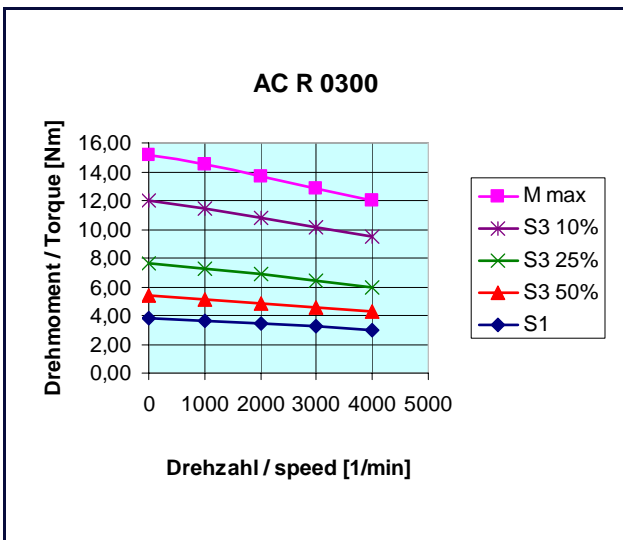
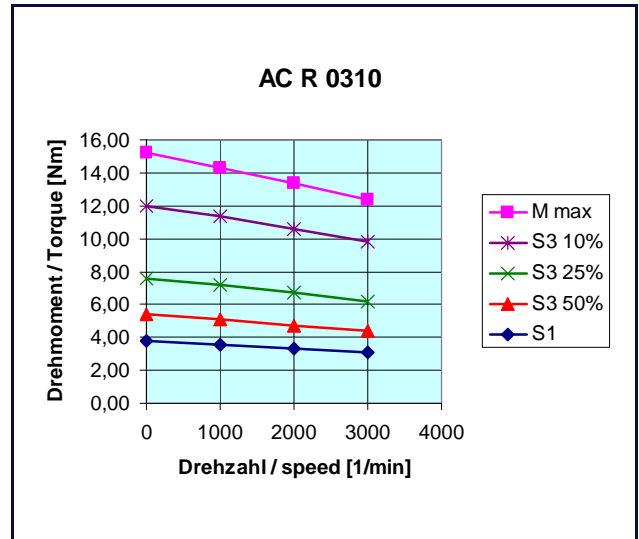
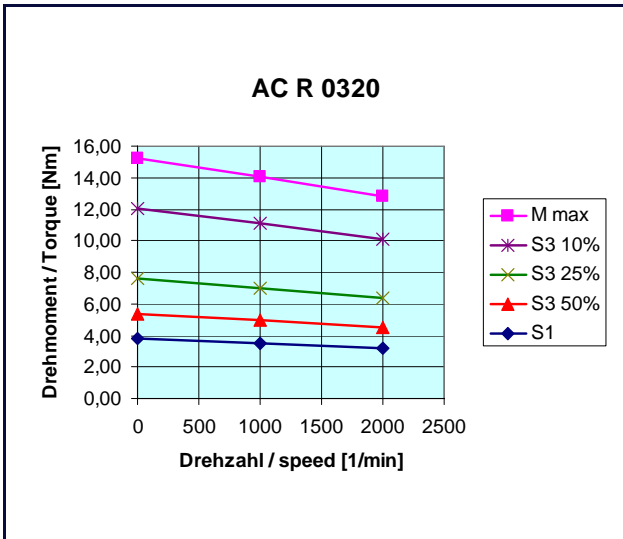
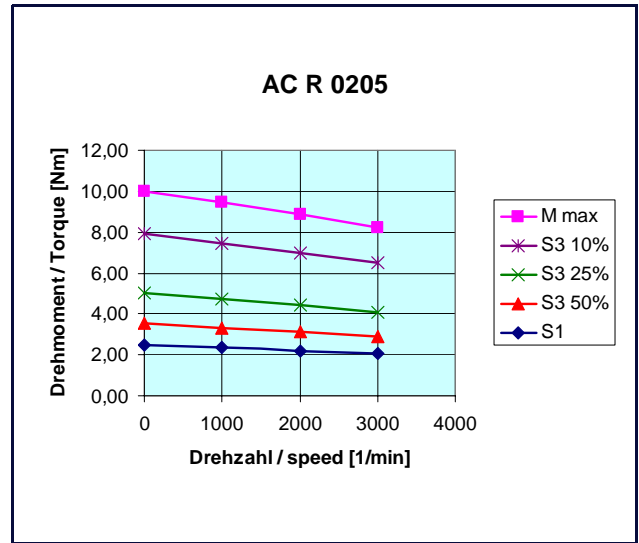
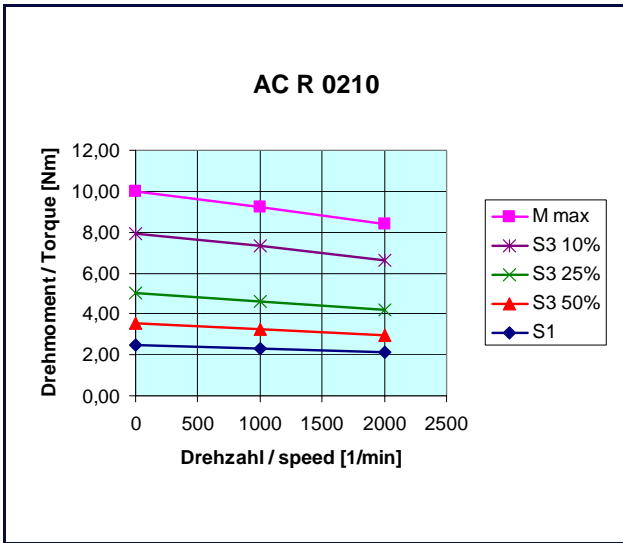

AC R; Motor size 2

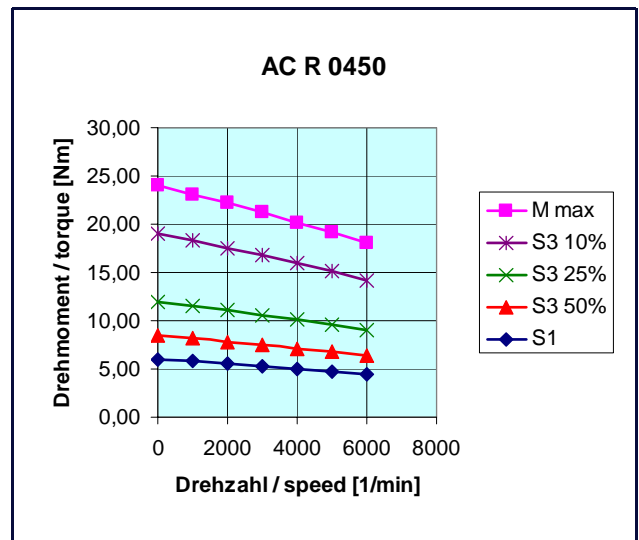
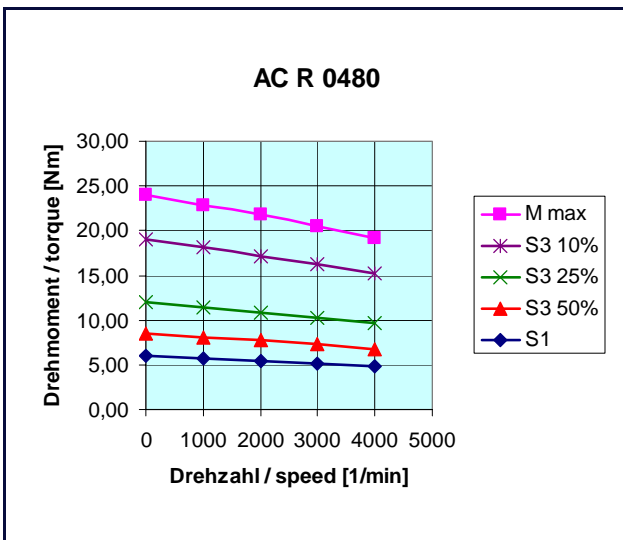
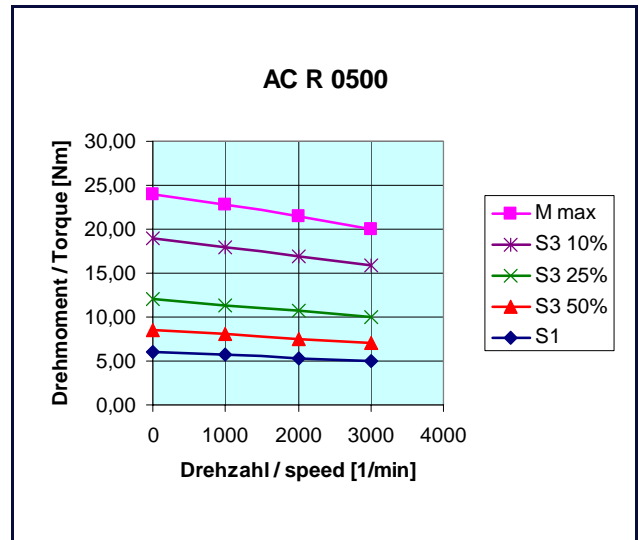
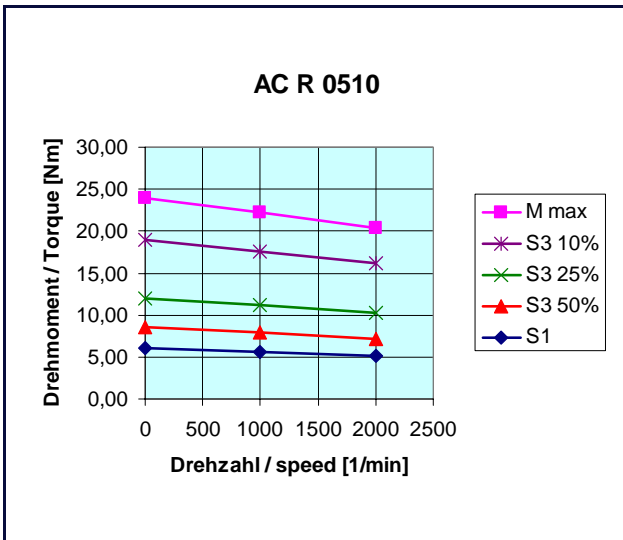

3 Technical Data

3.5.3 AC R; Motor size 3

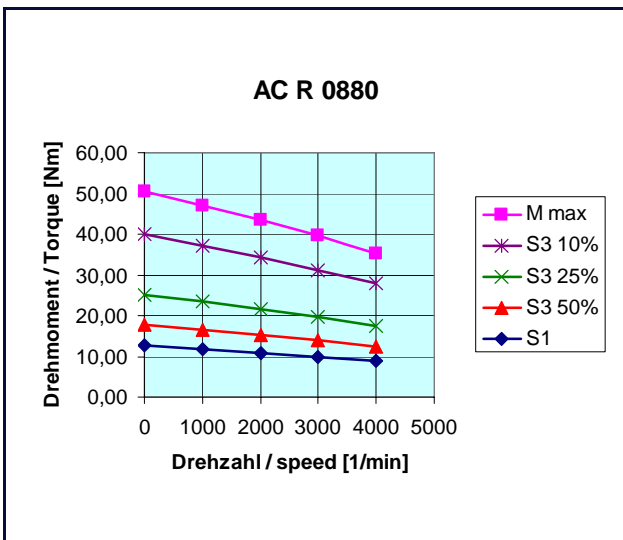
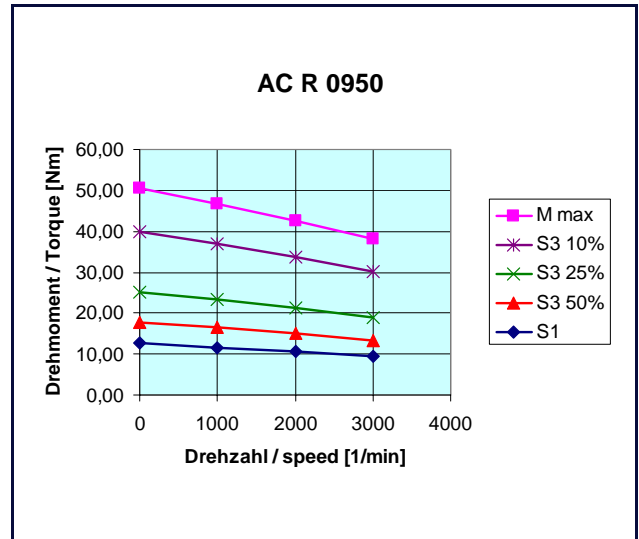
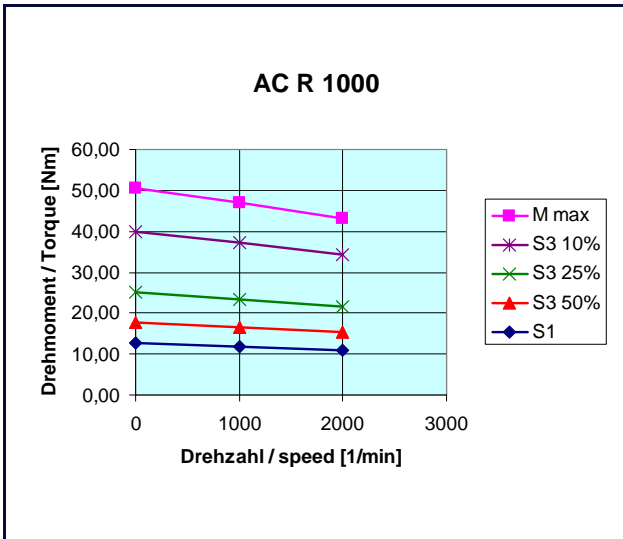
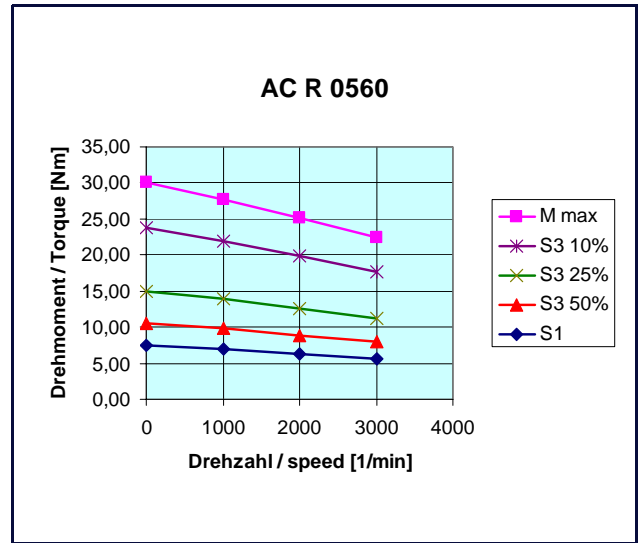
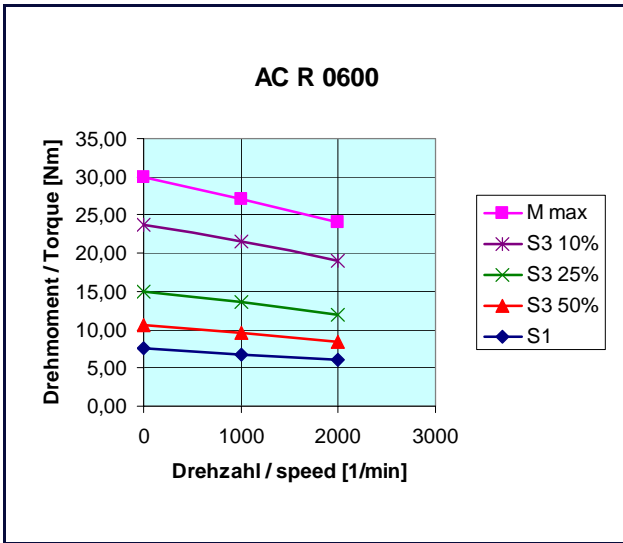

AC R; Motor size 3

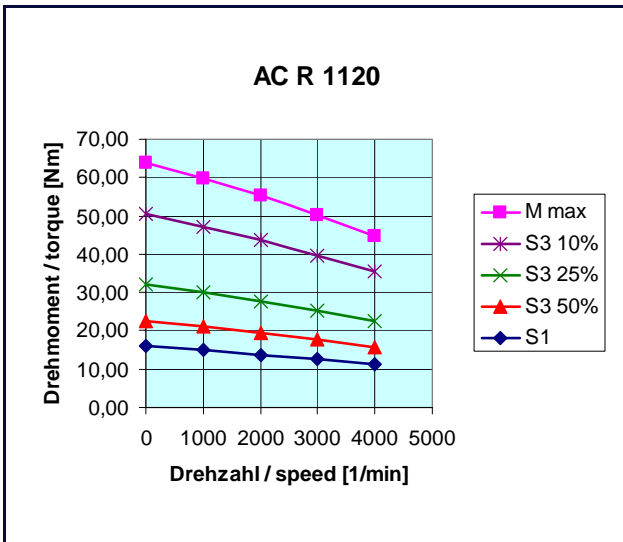
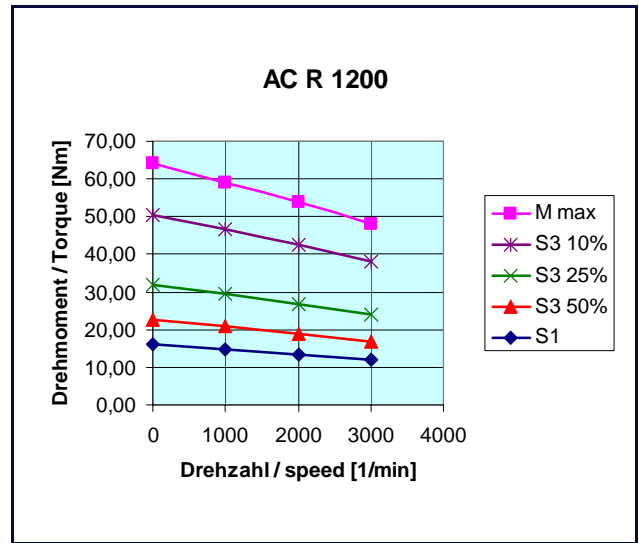
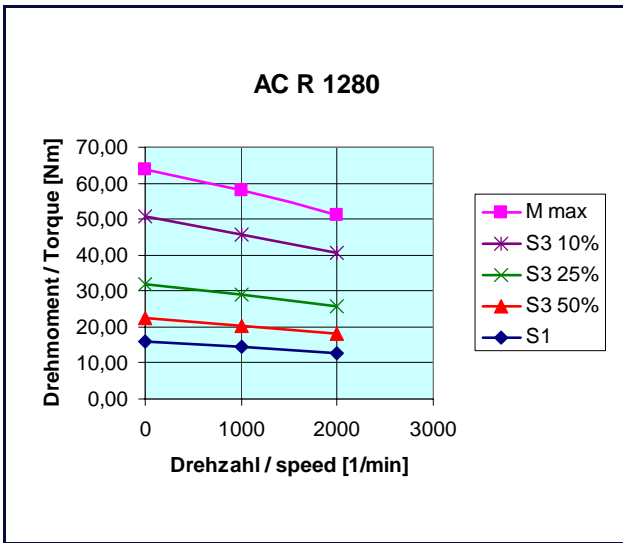

3 Technical Data

3.5.4 AC R; Motor size 4

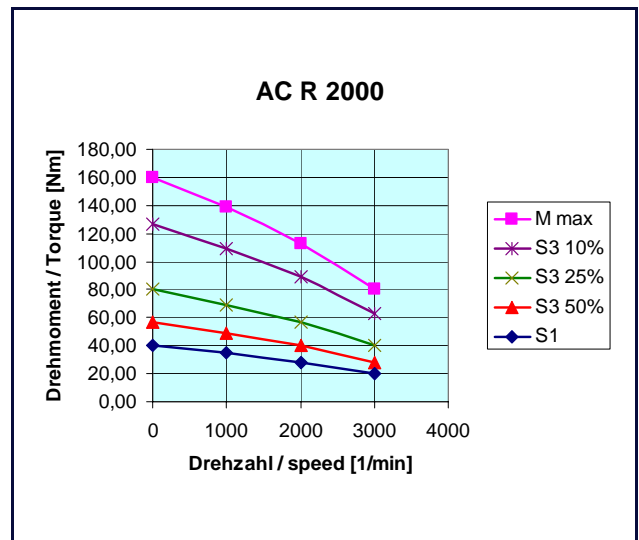
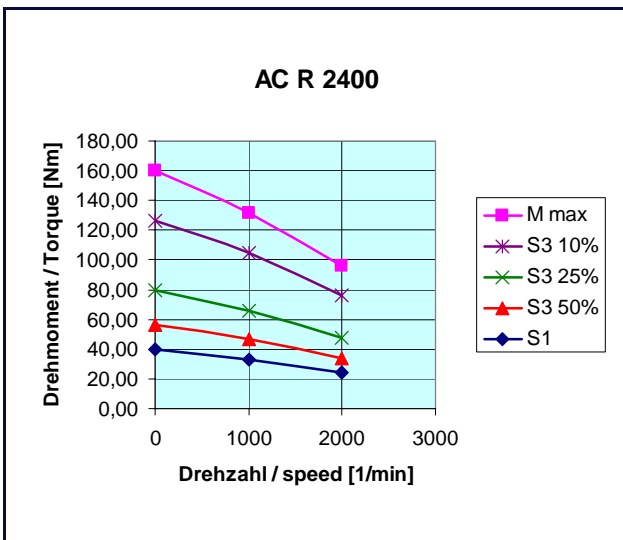
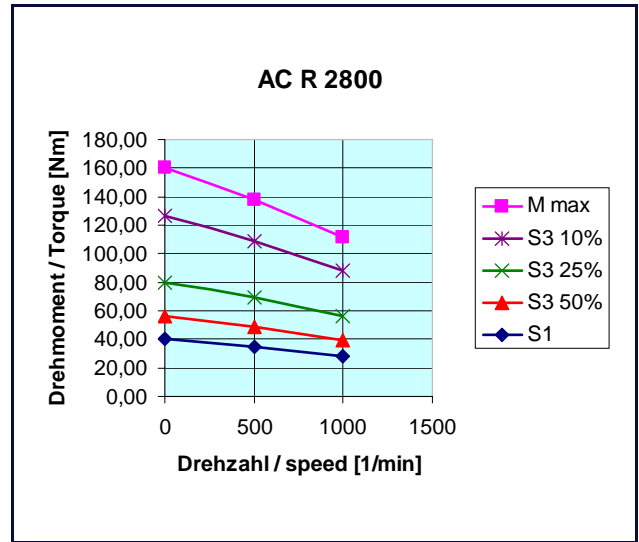
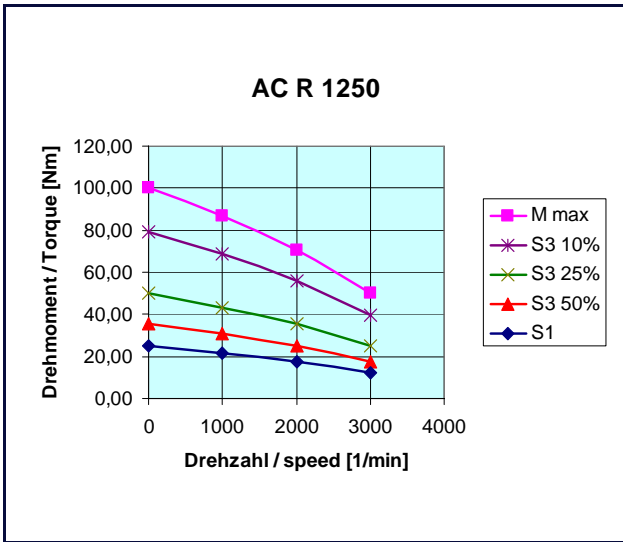
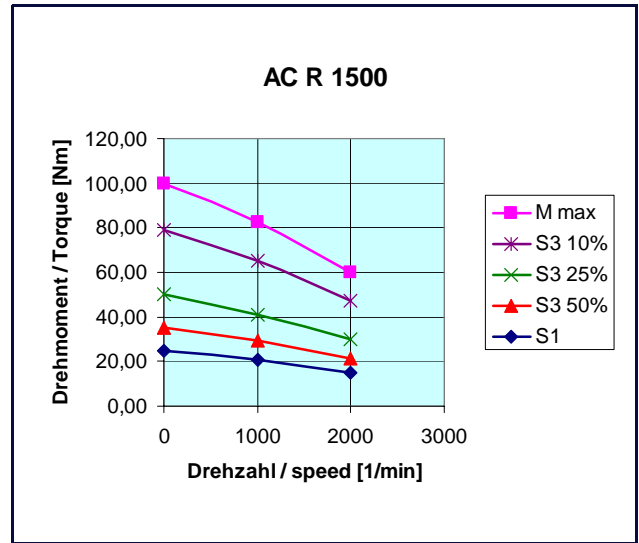
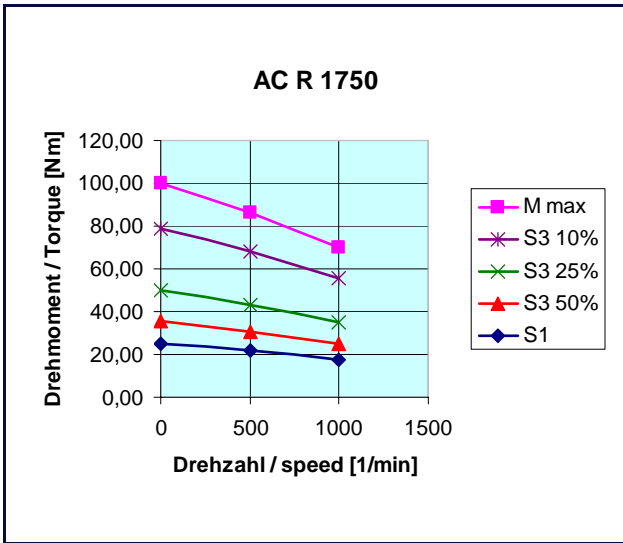

AC R; Motor size 4

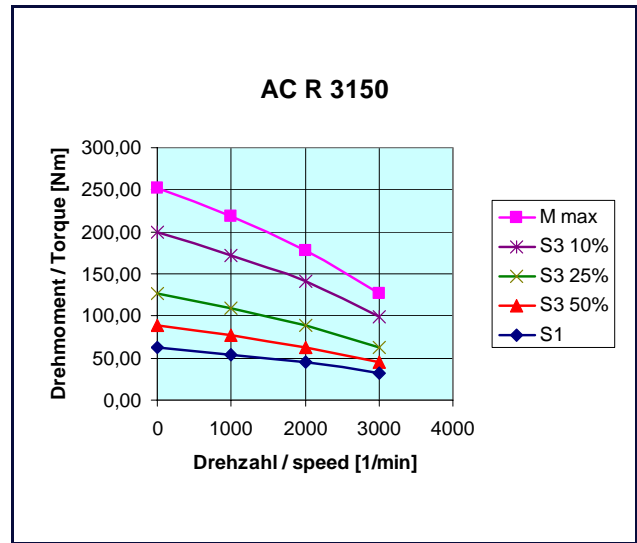
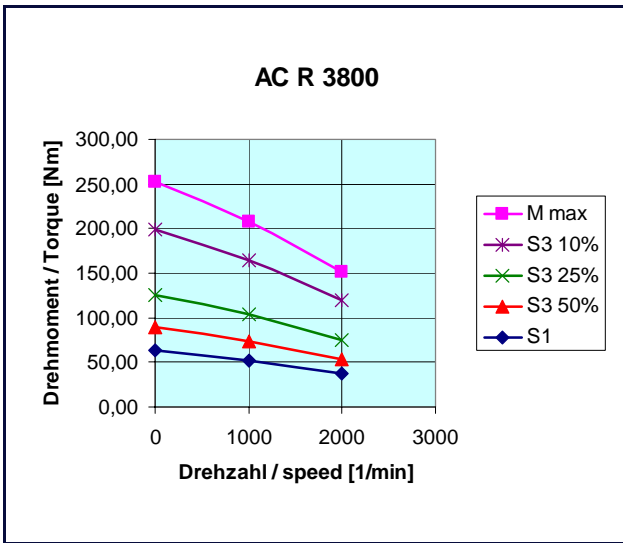

3.5.5 AC RL; Motor size 3 - 4
On request !

4 Dimensions

4.1 Motor size 1 – 4, without separate fan (AC R)

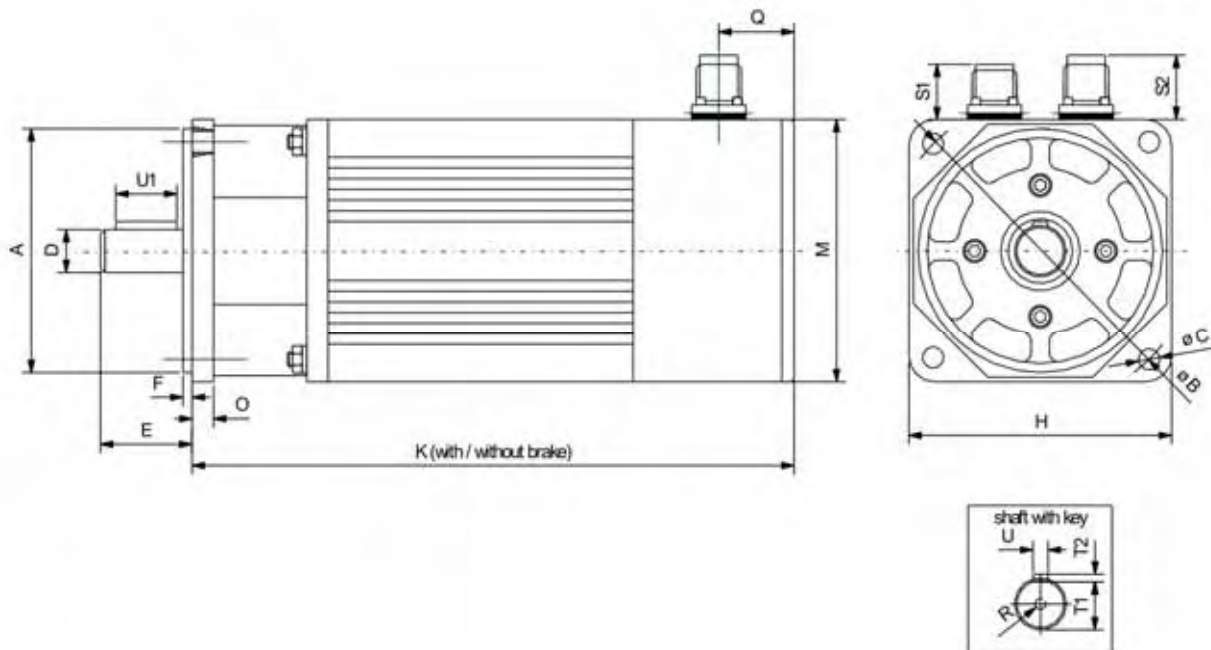

AC R BG	A (j6)	B	C	D (k6)	E	F	H ± 2	K	M ± 2	O	Q	R	S1	S2	T1	T2	U	u1
1.1	80	100	7	14	30	3,0	86	200	88	6	28	M4x15	16	21	11,1	5h9	5h9	20
1.2	80	100	7	14	30	3,0	86	215	88	6	28	M4x15	16	21	11,1	5h9	5h9	20
1.3	80	100	7	14	30	3,0	86	230	88	6	28	M4x15	16	21	11,1	5h9	5h9	20
2.1	95	115	9	19	40	3,0	105	240	115	8	33	M6x20	18	21	15,5	6h9	6h9	30
2.2	95	115	9	19	40	3,0	105	255	115	8	33	M6x20	18	21	15,5	6h9	6h9	30
2.3	95	115	9	19	40	3,0	105	285	115	8	33	M6x20	18	21	15,5	6h9	6h9	30
3.1	130	165	11	24	50	3,5	145	270	145	12	33	M8x25	25	21	19,9	7h11	8h11	40
3.2	130	165	11	24	50	3,5	145	300	145	12	33	M8x25	25	21	19,9	7h11	8h11	40
3.3	130	165	11	24	50	3,5	145	345	145	12	33	M8x25	25	21	19,9	7h11	8h11	40
4.1	180	215	14	32	58	4,0	185	350	187	13	42	M10x25	25	21	27,3	8h11	10h11	50
4.2	180	215	14	32	58	4,0	185	395	187	13	42	M10x25	25	21	27,3	8h11	10h11	50
4.3	180	215	14	32	58	4,0	185	470	187	13	42	M10x25	25	21	27,3	8h11	10h11	50

All dimensions in "mm"

optional: Absolute- or incremental encoder preparation of attachment (AI0)

- dimension drawing - on request
- dimension "K" appr. +35mm (without encoder)

4.2 Motor size 3 – 4, with separate fan (AC RL)

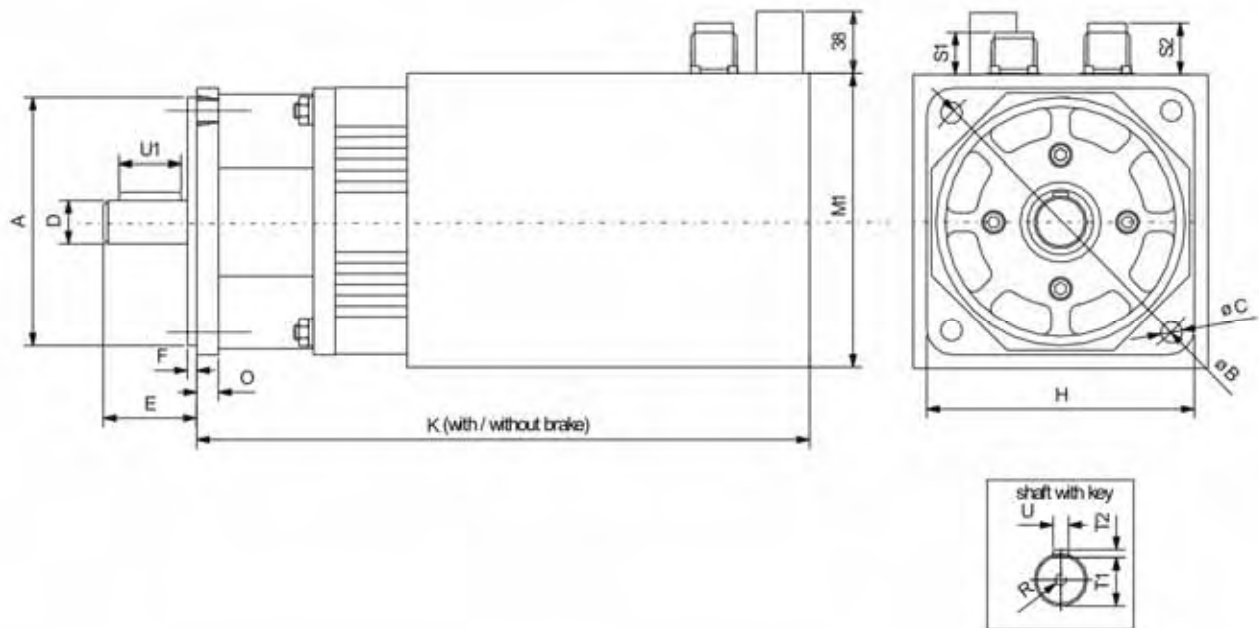

AC RL BG	A (j6)	B	C	D (k6)	E	F	H ± 2	K	M1 ± 3	O	R	S3	S4	T1	T2	U	u1
3.1	130	165	11	24	50	3,5	145	370	165	12	M8x25	25	21	19,9	7h11	8h11	40
3.2	130	165	11	24	50	3,5	145	400	165	12	M8x25	25	21	19,9	7h11	8h11	40
3.3	130	165	11	24	50	3,5	145	445	165	12	M8x25	25	21	19,9	7h11	8h11	40
4.1	180	215	14	32	58	4,0	185	463	210	13	M10x25	25	21	27,3	8h11	10h11	50
4.2	180	215	14	32	58	4,0	185	508	210	13	M10x25	25	21	27,3	8h11	10h11	50
4.3	180	215	14	32	58	4,0	185	583	210	13	M10x25	25	21	27,3	8h11	10h11	50

All dimensions in "mm"

5 Connector Assignment

5.1 Terminal Connection

5.1.1 Terminal strip motor size 1 at 2

power plug

motor side

motor size 1...2

type: AC R / AC RL

terminal strip

drive side

servo drive of the 630`series

type: in the compact enclosure

view solder / crimp connector - side

S MB RPM BG0/2 ST.0100.0001		KMB BG0/2-B KA.0003.6304		terminal strip
PIN - Nr.		colour	function	-
A		black 1	motor connection	M3 (W)
B		black 2	motor connection	M2 (V)
C		black 3	motor connection	M1 (U)
D	1)	yellow / green	ground connection	PE
E		red	brake +24V DC	connection not on terminal
F		blue	brake 0V DC	
case	1)			case

1)
The screen is connected at the connector pin and also to the connector shell

2)
Attention ! Safety and insulation:
The brake must be insulated for protective separation (PELV). Otherwise the insulation class of the drive becomes reduced or the use of an additional galvanic separation is required

			Maßstab / scale:		Blatt sheet 1
			Typ / type: KK MB RPM 0/2.K - XX.X / B KK MB RPM 0/2.638 - XX.X / B		
Bear. 28.03.07 DL			Bezeichnung / designation: Blue motor cable for AC R(L) motors and drives (compact enclosure)		
Gep. 02.04.07 EH					
Norm			Zeichnungsnummer / drawing No: Z-MK.6300.xxxx		
Zust.	Änderung	Datum	Name	Ursprung	Dateiname / File name: Z-MK-6300-E.cdr

5.1.2 Terminal strip motor size 3

<p>power plug</p> <p>motor side</p> <p>motor size 3</p> <p>type: AC R / AC RL</p>	<p>terminal strip</p> <p>drive side</p> <p>servo drive of the 630`series</p> <p>type: in the <u>compact enclosure</u></p>																																																			
<p>view solder / crimp connector - side</p>																																																				
<table border="1" style="width: 100%; border-collapse: collapse;"> <thead> <tr> <th style="width: 25%;">S MB RPM BG3 ST.0100.1001</th> <th style="width: 25%;">KMB BG3-B KA.0003.6302</th> <th style="width: 25%;"></th> <th style="width: 25%;">terminal strip</th> </tr> </thead> <tbody> <tr> <td>PIN - Nr.</td> <td>colour</td> <td>function</td> <td>-</td> </tr> <tr> <td>A</td> <td>black 1</td> <td>motor connection</td> <td>M3 (W)</td> </tr> <tr> <td>B</td> <td>black 2</td> <td>motor connection</td> <td>M2 (V)</td> </tr> <tr> <td>C</td> <td>black 3</td> <td>motor connection</td> <td>M1 (U)</td> </tr> <tr> <td>D</td> <td>1) yellow / green</td> <td>ground connection</td> <td>PE</td> </tr> <tr> <td>E</td> <td>red</td> <td>brake +24V DC 2)</td> <td rowspan="2">connection not on terminal</td> </tr> <tr> <td>F</td> <td>blue</td> <td>brake 0V DC</td> </tr> <tr> <td>case</td> <td>1)</td> <td></td> <td>case</td> </tr> </tbody> </table>		S MB RPM BG3 ST.0100.1001	KMB BG3-B KA.0003.6302		terminal strip	PIN - Nr.	colour	function	-	A	black 1	motor connection	M3 (W)	B	black 2	motor connection	M2 (V)	C	black 3	motor connection	M1 (U)	D	1) yellow / green	ground connection	PE	E	red	brake +24V DC 2)	connection not on terminal	F	blue	brake 0V DC	case	1)		case																
S MB RPM BG3 ST.0100.1001	KMB BG3-B KA.0003.6302		terminal strip																																																	
PIN - Nr.	colour	function	-																																																	
A	black 1	motor connection	M3 (W)																																																	
B	black 2	motor connection	M2 (V)																																																	
C	black 3	motor connection	M1 (U)																																																	
D	1) yellow / green	ground connection	PE																																																	
E	red	brake +24V DC 2)	connection not on terminal																																																	
F	blue	brake 0V DC																																																		
case	1)		case																																																	
<p>1) The screen is connected at the connector pin and also to the connector shell</p>		<p>2) Attention ! Safety and insulation: The brake must be insulated for protective separation (PELV). Otherwise the insulation class of the drive becomes reduced or the use of an additional galvanic separation is required</p>																																																		
<table border="1" style="width: 100%; border-collapse: collapse;"> <tr> <td colspan="3" style="text-align: center;"></td> <td colspan="2">Maßstab / scale:</td> </tr> <tr> <td colspan="3"></td> <td colspan="2">Typ / type:</td> </tr> <tr> <td colspan="3"></td> <td colspan="2" style="text-align: center;">KK MB RPM 3.K - XX.X / B</td> </tr> <tr> <td colspan="3"></td> <td colspan="2">Bezeichnung / designation:</td> </tr> <tr> <td colspan="3"></td> <td colspan="2" style="text-align: center;">Blue motor cable for AC R(L) motors and drives (compact enclosure)</td> </tr> <tr> <td colspan="3"></td> <td colspan="2">Zeichnungsnummer / drawing No:</td> </tr> <tr> <td colspan="3"></td> <td colspan="2" style="text-align: center;">Z-MK.6303.xxxx</td> </tr> <tr> <td colspan="3"></td> <td colspan="2" style="text-align: right;">Blatt sheet</td> </tr> <tr> <td colspan="3"></td> <td colspan="2" style="text-align: center;">1</td> </tr> <tr> <td>Zust.</td> <td>Änderung</td> <td>Datum</td> <td>Name</td> <td>Ursprung</td> <td>Dateiname / File name: Z-MK-6303-E.cdr</td> </tr> </table>					Maßstab / scale:					Typ / type:					KK MB RPM 3.K - XX.X / B					Bezeichnung / designation:					Blue motor cable for AC R(L) motors and drives (compact enclosure)					Zeichnungsnummer / drawing No:					Z-MK.6303.xxxx					Blatt sheet					1		Zust.	Änderung	Datum	Name	Ursprung	Dateiname / File name: Z-MK-6303-E.cdr
			Maßstab / scale:																																																	
			Typ / type:																																																	
			KK MB RPM 3.K - XX.X / B																																																	
			Bezeichnung / designation:																																																	
			Blue motor cable for AC R(L) motors and drives (compact enclosure)																																																	
			Zeichnungsnummer / drawing No:																																																	
			Z-MK.6303.xxxx																																																	
			Blatt sheet																																																	
			1																																																	
Zust.	Änderung	Datum	Name	Ursprung	Dateiname / File name: Z-MK-6303-E.cdr																																															

5 Connector Assignment

5.1.3 Terminal strip motor size 4

power plug

motor side

motor size 4

type: AC R / AC RL

terminal strip

drive side

servo drive of the 630`series

type: in the compact enclosure

view solder / crimp connector - side

S MB R BG4 ST.0100.2001	KMB BG4-B KA.0003.6303	terminal strip
PIN - Nr.	colour	function
A	black 1	motor connection
B	black 2	motor connection
C	black 3	motor connection
D	1) yellow / green	ground connection
E	red	brake +24V DC 2)
F	blue	brake 0V DC
case	1)	case

1)
The screen is connected at the connector pin and also to the connector shell

2)
Attention ! Safety and insulation:
The brake must be insulated for protective separation (PELV). Otherwise the insulation class of the drive becomes reduced or the use of an additional galvanic separation is required

			Maßstab / scale:		Blatt sheet 1
			Typ / type: KK MBR 4.K - XX.X / B		
Bear.		28.03.07	DL		Bezeichnung / designation: Blue motor cable for AC R(L) motors and drives (compact enclosure)
Gep.		02.04.07	EH		
Norm					
Zeichnungsnummer / drawing No: Z-MK.6304.xxxx					
Zust.	Änderung	Datum	Name	Ursprung	Dateiname / File name: Z-MK-6304-E.cdr

5.2 X50 - Terminal Connection

5.2.1 X50 – Terminal strip / motor size 1 at 2

power plug

motor side

motor size 1...2

type: AC R / AC RL

X50 - terminal strip

rack side / drive side

servo drive of the 630`series

type: rack version

view solder / crimp connector - side

S MB RPM BG0/2 ST.0100.0001	KMB BG0/2-B KA.0003.6304		X50 connector strip	³⁾
PIN - Nr.	colour	function	-	
A	black 1	motor connection	18	20
B	black 2	motor connection	14	16
C	black 3	motor connection	10	12
D	¹⁾ yellow / green	ground connection	case	
E	red	brake +24V DC	²⁾ -	
F	blue	brake 0V DC	-	
case	¹⁾		case	

¹⁾
The screen is connected at the connector pin and also to the connector shell

²⁾
Attention ! Safety and insulation:
The brake must be insulated for protective separation (PELV). Otherwise the insulation class of the drive becomes reduced or the use of an additional galvanic separation is required

³⁾
not in the scope of delivery

			Maßstab / scale:		Blatt sheet 1
			Typ / type: KK MB RPM 0/2.R - XX.X / B		
			Bezeichnung / designation: Blue motor cable (plug/terminal strip) for AC R/L) motors and servo drives (rack version)		
			Zeichnungsnummer / drawing No: Z-MK.0600.xxxx		
Zust.	Änderung	Datum	Name	Ursprung	Dateiname / File name: Z-MK-0600-E.cdr

5 Connector Assignment

5.2.2 X50 – Terminal strip / motor size 3

power plug

motor side

motor size 3

type: AC R

X50 - terminal strip

rack side / drive side

servo drive of the 630` series

type: rack version

view solder / crimp connector - side

S MB RPM BG3 ST.0100.1001		KMB BG0/2-B KA.0003.6303		X50 connector strip	³⁾
PIN - Nr.		colour	function	-	
A		black 1	motor connection	18	20
B		black 2	motor connection	14	16
C		black 3	motor connection	10	12
D	¹⁾	yellow / green	ground connection	case	
E		red	brake +24V DC	²⁾	-
F		blue	brake 0V DC		-
case	¹⁾			case	

¹⁾ The screen is connected at the connector pin and also to the connector shell

²⁾ **Attention ! Safety and insulation:**
The brake must be insulated for protective separation (PELV). Otherwise the insulation class of the drive becomes reduced or the use of an additional galvanic separation is required

³⁾ not in the scope of delivery

				Maßstab / scale:	
				Typ / type: KK MB RPM 3.R - XX.X / B	
Bear.		28.03.07	DL	Bezeichnung / designation: Blue motor cable (plug/terminal strip) for AC R/L motors and servo drives (rack version)	
Gep.		02.04.07	EH		
Norm					
				Zeichnungsnummer / drawing No: Z-MK.0603.xxxx	
				Blatt sheet 1	
Zust.	Änderung	Datum	Name	Ursprung	Dateiname / File name: Z-MK-0603-E.cdr

5.2.3 X50 – Terminal strip / motor size 4

power plug

motor side

motor size 4

type: AC R

X50 - terminal strip

rack side / drive side

servo drive of the 630`series

type: rack version

view solder / crimp connector - side

S MB RPM BG4-L ST.0100.2001	KMB BG4-B KA.0003.6303		X50 connector strip	3)
PIN - Nr.	colour	function	-	
A	black 3	motor connection	18 20	
B	black 2	motor connection	14 16	
C	black 1	motor connection	10 12	
D	1) yellow / green	ground connection	case	
E	red	brake +24V DC	2) -	
F	blue	brake 0V DC	-	
case	1)		case	

1)
The screen is connected at the connector pin and also to the connector shell

2)
Attention ! Safety and insulation:
The brake must be insulated for protective separation (PELV). Otherwise the insulation class of the drive becomes reduced or the use of an additional galvanic separation is required

3)
not in the scope of delivery

				Maßstab / scale:	
				Typ / type:	
				KK MB RPM 4.R - XX.X / B	
				Bezeichnung / designation:	
				Blue motor cable (plug/terminal strip) for AC R/L motors and servo drives (rack version)	
				Zeichnungsnummer / drawing No:	
				Z-MK.0604.xxxx	
				Blatt sheet	
				1	
Zust.	Änderung	Datum	Name	Ursprung	Dateiname / File name: Z-MK-0604-E.cdr

5 Connector Assignment

5.3 Resolver connector

resolver plug

motor side

motor size all

type: AC G;
AC M2n; ACM2G-NL;
AC R / AC RL

view solderside

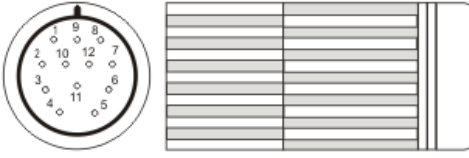

X30-resolver plug

drive side

servo drives of the 630'series

type: all

view solderside

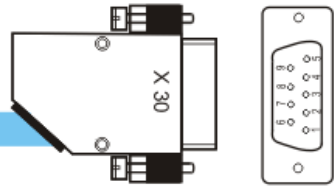

SIR ST.0200.0001	KIR -B KA.0003.6301		SUB - D 09 S/M ST.1002.2001
PIN - Nr.	colour	function	PIN - Nr.
1	white	sin +	4
2	brown	sin -	8
3	green	cos +	3
4	yellow	cos -	7
5	red	PTC optional	2
6	blue	PTC optional	6
7	pink	carrier -	9
8	gray	carrier +	5
case		screen	case

			Maßstab / scale:		Typ / type: KK RT GMR-xx.x/B	
			Bear.	28.03.07		
			Gep.	02.04.07	EH	Bezeichnung / designation: Blue resolver cable for standard motors and servo drives (not for NX and EX)
			Norm			
			Zeichnungsnummer / drawing No: Z-RK.6300.xxxx			Blatt sheet 1
Zust.	Änderung	Datum	Name	Ursprung	Dateiname / File name: Z-RK.6300-E.cdr	

5.4 Fan connection for motor series AC RL; motor size 2..4 (terminal box)

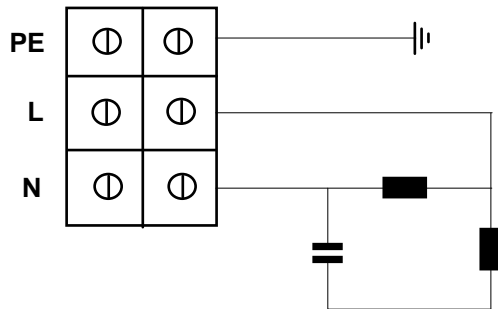

Supply voltage: 1 * 230VAC, 50..60Hz

Fan - power supply capacity and power input

Motor size BG	P _{Fan} (W)	I _{Fan} (A)
3	20	ca. 0,10
4	27	ca. 0,12

5 Connector Assignment

5.5 Wiring Instructions

Important rules when operating servo drives and servo motors:

Before any connections are made, it is necessary to make certain that the power to cabinet is off. It is necessary to explicitly follow the connection directions as outlined in the product documentation

and to employ the prescribed type and quality of cable that is recommended there.

1. A radio interference suppression level cannot be maintained without an interference suppression filter at the line input. Moreover, line filters increase the immunity of the system to interference.
2. The cable between the power electronics and the motor must be shielded as YCY. A SY shield is not suitable. The shield support for the power cable (motor cable) must be on both ends. We recommend using our motor cables!
3. Metal parts in the switching cabinet must be connected with each other having large areas of contact and must carry high frequencies very well. Avoid anodized, yellow-passivating and painted surfaces which can have very high resistance values based on the frequency! Make sure that the metals lie close together in the chemical electromotive series! Use the good conductivity and the large surface of the galvanized mounting plate as earth potential!
4. Relays, contactors and solenoid valves built into the same circuit must be connected with spark-suppressing components limiting over voltage spikes. This applies also if these parts are not mounted in the same cabinet as the servo regulator.
5. The shield for the analog signal lines must be installed on one end and, if possible, in the switching cabinet. Ensure a connection which provides extensive contact and which is low - resistant! The shield for the digital signal lines must be installed on both ends, must have extensive contact and must be low resistance. An additional equalizer is to be laid parallel when there are potential differences. It is necessary to use plugs with metal enclosures with separable connections.
6. Avoid unnecessary extra loops on all connecting cables. All measures regarding filtering and shielding can be short circuited on them with high frequency. Connect unused wires in cables on both ends to the equipment ground conductor.
7. Unshielded cables of a circuit, the conductors going out and returning, should be twisted due to symmetrical interferences.
8. Separate physically "live" and "dead" wires even in the planning phase. Give special attention to the motor cables. The area of the common terminal strip-line input and motor output is especially endangered.
9. Relays, contactors and solenoid valves. The cables should be laid in the switching cabinet as close as possible to the ground; wires hanging freely in the air are preferred EMC victims as well as active and passive aeriels.
10. When operating with more than one line component in a common network, EMC problems are to be expected. From the start, the installation planner must integrate in his concept high frequency emitted interference as well as the electromagnetic susceptibility of the components to one another and take measures against it.
11. It is absolutely necessary to run cable shields completely up to the connectors. The connection of the cable shields to ground must be near the servo regulator (10 - 50 cm). Sensitive measuring leads should be as far as possible from this area; this applies also when they are shielded!
12. It is mandatory to run the motor cables in a separate cable channel and to lay flexible cable shielding also when these are shielded. This channel must be separated at least 30 - 40 cm from the channel for the signal lines.

5.6 Plug designation

5.6.1 Mating plugs for motor- and brake connections

Size	Plug designation	Item – No.
1 - 2	SMB RPM BG 0/2	ST.0100.0001
3	SMB RPM BG 3	ST.0100.1001
4	SMB R BG 4	ST.0100.2001

5.6.2 Mating plugs for resolver- and thermal connection

Size	Plug designation	Item – No.
1 - 2	SIR	ST.0200.0001

5.7 Cable designation

5.7.1 Motor cable

Size	Cable designation	Item – No.
1 - 2	K MB BG 0/2 – B	KA.0003.6304
3	K MB R BG 3 – B	KA.0003.6302
4	K MB R BG 4 – B	KA.0003.6303

5.7.2 Resolver cable

Size	Cable designation	Item – No.
1 - 4	K IR – B	KA.0001.6301

6 Holding Brake

6.1 Technical data of the holding brake

Motor-size	Holding Brake Type:	Holding torque ²⁾	Current input	Switching time		Moment of inertia	Mass
				on ¹⁾	off ¹⁾		
(-)	(-)	M _{Br} (Nm)	I _{NBr} (A)	T _{ein} (ms)	T _{aus} (ms)	J (kgcm ²)	m _{Br} (kg)
1	BB R BG 1	5,0	0,59	7	15	1,06	0,6
2	BB R BG 2	10,0	0,65	20	29	1,10	0,6
3	BB R BG 3	19,0	0,71	25	50	3,60	2,0
4	BB R BG 4.3	80,0	1,20	30	90	32,00	3,8
4	BKH ³⁾	50,0	2,00	25	50	35,00	-

¹⁾ Brake open

²⁾ Holding torque at warm condition (+40°C) and ground-in, free of grease and corrosion brake pad.

³⁾ Special brake with additional hand operation

Supply voltage:

BB U_S = 24 V DC, ± 10% of the rated voltage to DIN IEC 38

Principle regulated and adjustable 24 V of power supply should be devoted around mains power supply variations to suppress or to compensate for voltage drops on cable and contacts. The voltage drop along the motor cable can be calculated with the following formula.

$$\Delta U_B = X * I_{\text{cable}}(m) * I_{\text{NBR}}(A)$$

X = for our cable (K MB BG 0/2 – B, K K MB R BG 3 – B, K MB R BG 4 – B)
= 0,072

Motor length:

The brake is build into the A flange and has no effect on the total length of the motors.

The inserted brake is not characterized for the general slowing-down the drives, but is merely a standstill and/or holding brake.

Therefore, it must become guaranteed by the customer that the drive stands, before that brake comes in. Should that brake not only become employed in the case of standing drives, so it's generally the wear and therefore the holding torque of the brake depending on:

- the speed of the drive with which the brake will be switched
- the load moment of inertia on the drive
- environmental conditions as temperature and so forth.
- the number of braking and so forth

7.1 Representation of the definition

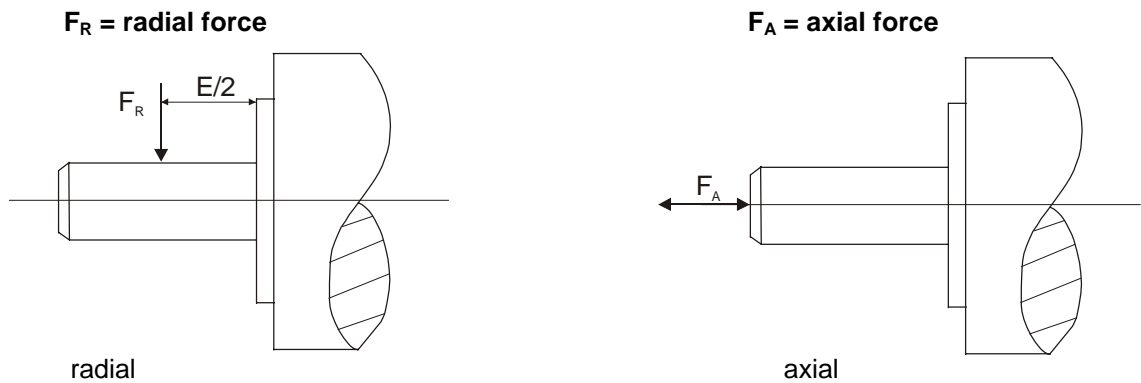

7.2 Technical data of the max. radial FR [N] and axial FA [N] Shaft loads (rated speed)

Motor- Size	Rated Speed	Max. radial Shaft loads	Max. axial Shaft loads
[-]	n_N [min ⁻¹]	F_R [N]	F_A [N]
1	2000	675	only slight force permitted, specific values only on request!
	3000	610	
	4000	575	
	6000	540	
2	2000	680	
	3000	620	
	4000	580	
	6000	540	
3	2000	850	
	3000	750	
	4000	680	
4	1000	2450	
	2000	1950	
	3000	1700	

The specifications refer to 15000 hours of operation.

8 Nominal Power - Dependence

8.1 Nominal Power – Dependence upon the Installation Altitude of the Servo Motor

When selecting an appropriately sized motor, the following needs to be considered:

Workload (power), operating mode, starting, braking and by-pass processes, additional moment of inertia and additional characteristics of the equipment installation, including speed control if necessary, net ratios, coolant temperature, installation altitude etc.

The nominal power is the power that is mechanically available at the drive shaft, if the installation site is not located above 1,000 meters above sea level, (MSL), the air temperature does not exceed

40° C, and the net ratios are normal. With differing installation parameters concerning installation altitude and air temperature, the anticipated nominal power availability must be corrected utilizing the following graph:

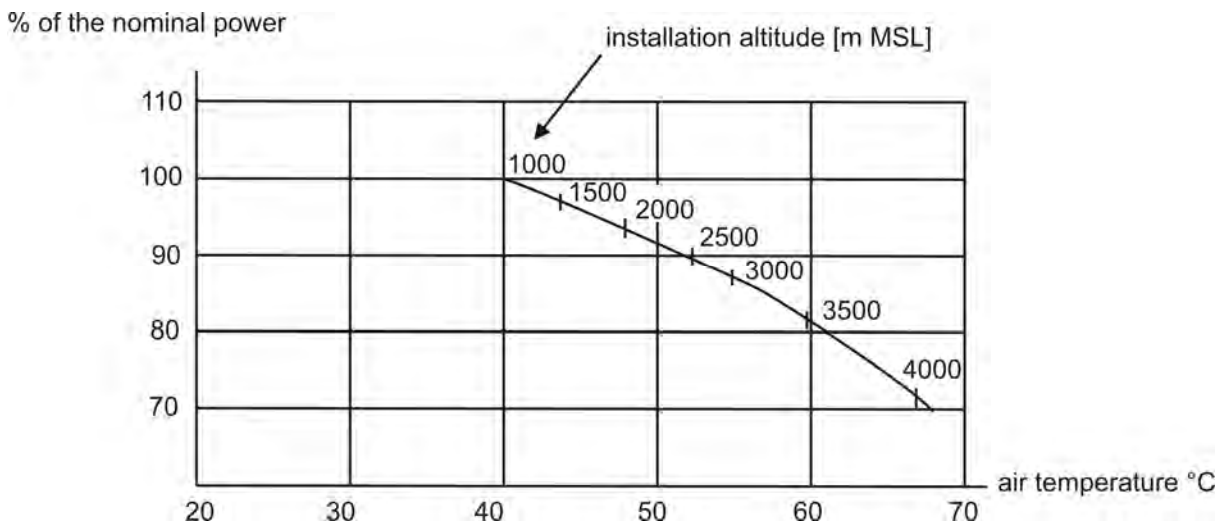

Check the air temperature and the installation altitude separately. Should there be differing air temperatures and installation altitudes concurrently, the factors concerning available nominal power need to be multiplied.

9.1 Security and Safety Instructions

	<p>It is imperative that all relevant legal regulations and the instructions detailed in this document be explicitly followed when undertaking the handling, installation, usage and maintenance of the equipment.</p>
<p>Attention :</p>	<p>Strict adherence to the rules of operation is to be guaranteed by the operator.</p>
	<p>High Touch Voltage ! Electric Shock ! Danger of life !</p>
<p>Danger :</p>	<p>Contact with high voltage electricity can cause death or severe bodily damage.</p>
	<p>Opening of the servo motor case by the operator is not allowed due to safety and product guarantee considerations.</p>
<p>Caution :</p>	<p>Proper professional implementation is required for problem free operation of the servo motor! Possible results of improper implementation or activity include non-life threatening injuries.</p>
	<p>We accept no responsibility or liability for damage which is caused when the legal regulations and/or the product instructions are not explicitly followed.</p>
<p>Stop :</p>	<p>Damage to the servo motor and the area of installation are possible ramifications of non-adherence to the established regulations and instructions.</p>

9 Mounting / Installation

9.2 Mounting and Installation Instructions

9.2.1 General Preparation

- The installation should be designed to allow for access to the wiring connections and so that it is possible to read the name plate on the equipment.
- The equipment should be installed in a manner which allows for the free flow of air circulation around the unit to facilitate adequate cooling of the equipment.
- Only when the motor is protected from dust and water can the optimal life span and performance of the equipment be assured.
- The outgoing cable connections should be located underneath the unit to eliminate the potential for dust or moisture accumulating in the connection area.
- The motor shaft can be cleaned utilizing a cloth that has been moistened with benzene, alcohol or acetone. It is important however, to make certain that the cleaning fluid does not penetrate the unit housing.



Please note that the motor housing can reach temperatures in excess of 100° Celsius.

9.2.2 Mechanical Installation Preparation

- When installing a servo motors with a feather key check to make certain that the connection components without the feather key are well balanced.
- It is important to insure the proper installation alignment of the servo motor shaft with the shaft of the working machine so that movement, imbalance and excess stress on the shaft are eliminated.
- Avoid bumping the shaft and pressure fit connections as this can cause damage to the rolling-contact bearings. When work needs to be undertaken on the pressure fittings, we recommend securing the equipment to avoid unnecessary incidental movement.
Even when these steps are taken to minimize potential damage, the functional capability of the resolver may be negatively affected.
- Avoid bumping the shaft as this could interfere with the operation and function of the rolling bearings, pressure fittings or the working surface of the shaft.



Not Allowed

9.2.3 Electrical Connections

- Before any electrical connections are made it is important to make certain that all connections to the cabinet are off.
- The connections must be made according to the installation instructions for the servo drive.
- The cables and plugs which are employed must meet or exceed the quality specifications which we have prescribed.
- The cable cross-section employed must be chosen to insure that there is no voltage drop.

9.2.4 Rotational Direction of the Servo Motor

- When the cabling instructions are followed correctly then the anticipated rotations per minute of the servo drive can be achieved, with the rotation following a clock-wise direction, when looking at the shaft as shown.



10.1 Manufacturer's Declaration



**Standard Specifications and Certifications
Manufacturer's Declaration**

**In accordance with the EC – Machinery Directive 98/37/EG
approximation of the regulation of the member states for machinery.**

The following Products

AC – Servo - motors of series

AC R / AC RL

in standard design are components to be incorporated into machinery and may not be operated alone. The complete machinery or installation using this equipment may only be put into service when the safety considerations of the Directive 98/37/EG are fully adhered to.

The above mentioned products are in accordance with the relevant clauses from the following standards.

Basic directives:

- EN 60034 / VDE 0530
- IEC 34 – 1,5,6,8,9,14 / IEC 72 / IEC 85
- VDE 0100, VDE 0110, VDE 0530-1
- EC – MASCHINERY DIRECTIVE 98/37/EG
- EC – LOW VOLTAGE DIRECTIVE 73/23/EEC

CE – Label
as standard on the name plate.

Issuer:
Parker Hannifin GmbH & Co. KG.
Im Sand 14
76669 Bad Schönborn

Bad Schönborn, 26.04.2007

Legally binding signature

ppa. Erich Ehlen
Plant Manager

This declaration does not include any assertion of properties. The references for safety and protection (operating instruction) are to observe in every case keep.

11 Appendix

11.1 Special motor

AC R 1250-3/4-6-BKH (Special brake with additional hand operation)
 AC R 2000-3/4-6-BKH (Special brake with additional hand operation)

Note:

Hand lever operation only hand-held toward motor end → (approx. 5°).

Dimensions:

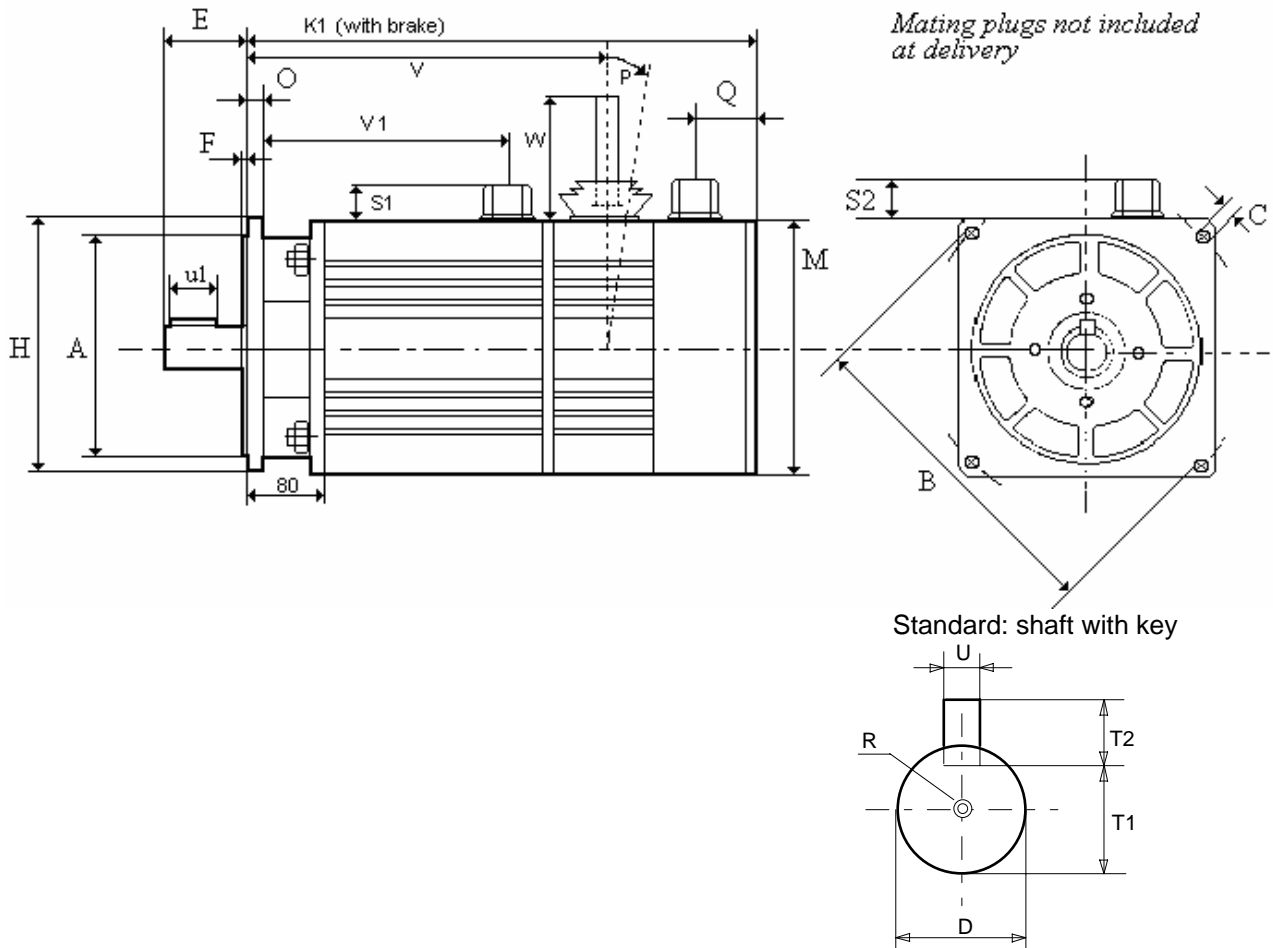

AC R .. size	A (j6)	B	C	D (k6)	E	F	H	K1 ca.	M	O	P ca. (°)	Q	R	S1	S2	T1	T2	u	u1	V ca.	V1 ca.	W ca.
4.1	180	215	14	32	58	4	185	508	187	13	5	26	M10·25	25	21	27,3	8h11	10h11	50	400	295	80
4.2	180	215	14	32	58	4	185	554	187	13	5	42	M10·25	25	21	27,3	8h11	10h11	50	450	342	80

All dimensions in "mm", except "P"

Remark:

With flanged on gearbox the output shaft (due to the gear reduction) is hardly rotatable also with released brake.

13 Modification Record

Version	Modification	Chapter	Date	Name	Comment
V08.08EH99	changed chapter new technical data new chapter new technical data text addition text modification new chapter	1.2/1.3 2 2.5 + 2.6 4.2 5.3 6 8	08.03.1999	K. Stadler	ET - Format
V0901	Separation German / English and complements correct dimensions	alle 4.1 + 4.2	14.02.2001 09.01.2003	N. Dreilich N. Dreilich	
V1004	SSD Drives	-	10.11.2004	N. Dreilich	Logos
V1105	Possible options Torque/Speed Diagrams new drawing connector drawing Appendix special motor	1.3 3.5 4.1 5 9	24.01.2005	N. Dreilich	Expansion New New New
V1206	data for BKH brake new ACR1250...BKH	6 9	16.05.2006	N. Dreilich	
V1307	modified all chapters Motor range shortened		03.05.2007		



We reserve the right to make technical changes. The data correspond to the current status at the time of printing.

Parker Hannifin GmbH & Co. KG
Electromechanical & Drives
Automation Group
Im Sand 14
D-76669 Bad Schönborn
Tel. +49(0) 7253/9404-0
Fax +49(0) 7253/9404-99
sales.automation@parker.com

Parker Hannifin GmbH & Co. KG
Electromechanical & Drives
Automation Group
Robert-Bosch-Straße 22
D-77656 Offenburg
Tel. +49(0) 781/509-0
Fax +49(0) 781/509-98176
sales.automation@parker.com

Parker Hannifin GmbH & Co. KG
Electromechanical & Drives
Automation Group
Von-Humboldt-Straße 10
D-64646 Heppenheim
Tel. +49(0) 6252/7982-0
Fax +49(0) 6252/7982-05
sales.automation@parker.com



www.parker-automation.com