

Operating Instructions Industrial Robot Controllers

Model No. **YA-HDA Series**



Model No.

YA-HDA801T**

YA-HDA801Y**

YA-HDA801E**

YA-HDA801R**

YA-HDA201T**

YA-HDA201Y**

YA-HDA201E**

YA-HDA201R**

For Large Robot YS-080WGIII , HH-020LWGIII

- Before operating this product, please read the instructions carefully and save this manual for future use. Please read the operating instructions of peripheral equipment together with it.
- First of all, please read "Safety precautions".

English version is the original instructions.

WMA132TE0PAA07

◆ Introduction

Thank you for purchasing our Panasonic arc welding robot TAWERS series. This manual is the Operating Instructions of YA-1TC series robot controllers.

For operation of the controller, refer to the “**Operating Instructions [Operation]**”. For operation of the robot manipulator, refer to the operating instruction of the manipulator.

◆ For Your Safety

- Please read and understand separately provided "Safety Manual" thoroughly for proper and safe operation of our robots.
- Prior to operation, read this manual for proper operation. Keep this manual in an easily accessible place and re-read as necessary.
- The installation shall be made by qualified installation personnel and should conform to all national and local codes.
- Only qualified service personnel may install or service the robot system.
- Ensure compliance with all local and national safety and electrical codes for the installation and operation of the robot system.

◆ Registered Trade Marks

Microsoft Windows and Windows CE are registered trade marks of Microsoft corporation in the United States and/or other countries.

PS/2 is a registered trade mark of International Business Machines Corporation.

* Other names of company and products are generally trade marks or registered trade marks of each company.

◆ Disclaimer

Panasonic Smart Factory Solutions Co., Ltd. (hereinafter called “PSFS”) and its affiliates (including any subcontractor, sales company or agent) shall not assume or undertake any responsibility or liability of the following:

- Any problem arising out of, or directly or indirectly attributable to, the failure of user to carry out those normal installation, normal maintenance, normal adjustment and periodical check of this Product.
- Any problem arising out of any Force Majeure, including but not limited to, act of God.
- Any malfunction or defect of this Product that is directly or indirectly the result of any malfunction or defect of one or more related parts or products that are not supplied by PSFS. Or any problem arising out of, or directly or indirectly attributable to, the combination of this Product with any other product, equipment, devices or software that is not supplied by PSFS.

- Any problem arising out of, or directly or indirectly attributable to, user's failure to strictly carry out or follow all of the conditions and instructions contained in this instruction manual, or user's misuse, mishandle, operational miss or abnormal operation.
- Any problem arising out of this Product or the use of it, the cause of which is other than the foregoing but is also not attributable to PSFS.
- Any claim of a third party that this Product infringes the intellectual property rights of such third party that are directly or indirectly caused by User's use of this Product and relate to the method of production.

ANY LOST PROFITS OR SPECIAL, INDIRECT, INCIDENTAL OR CONSEQUENTIAL DAMAGES IN CONNECTION WITH OR ARISING FROM ANY MALFUNCTION, DEFECT OR OTHER PROBLEM OF THIS PRODUCT.

- This operating instructions manual is based on the information as of October, 2020.
- The information in this operating instructions manual is subject to change without notice.

◆ Model numbers

Model Number	Specification
YA-HDA801***	YS-080WG III : 80 kg payload robot
YA-HDA201***	HH-020LWG III : 20 kg payload robot

Of the model number, "****" consists of one-letter "Model group" code followed by a "Manipulator type" code of two alphanumeric characters.

◆ Model group

Model group code	Model number	Code number	Basic design policy
T/Y	YA-HDA801T** YA-HDA801Y**	YA-1WC801T** YA-1WC801Y**	<p>T**: Standard model for Japanese market Y**: Standard model for general overseas markets</p> <p>This product does not meet the requirements specified in the EC Directives which are the EU safety ordinance. Please bear in mind that this product may not be brought as is into the EU. The same restriction also applies to any country which has signed the EEA accord.</p> <p>Please be absolutely sure to consult with us before attempting to relocate or resell this product to or in any EU member state or any other country which has signed the EEA accord.</p> <p><Note> If you intend to use the robots in US, Canada or EU member states (including countries signed the EEA accord), please purchase the robots designed for those countries. (See the following models.)</p>
	YA-HDA201T** YA-HDA201Y**	YA-1WC201T** YA-1WC201Y**	
E	YA-HDA801E** YA-HDA201E**	YA-1WC801E** YA-1WC201E**	<p>Standard model for EU nations.</p> <p>The robot is designed in accordance with the following European directives and harmonized standards. EU directives : 2006/42/EC and 2014/30/EU. EN standards : EN ISO 10218-1:2011, EN 60204-1:2006 +A1:2009, EN 60974-1:2012, EN 60974-5:2013, EN 61000-6-4:2007+A1:2011, EN 61000-6-2:2005 and EN 60974-10:2014+A1:2015.</p> <p>Before put into service the Robot in the European market the Robot system shall be designed in accordance with the manufacturers specification described in this manual and instruction manual. Remodeling and/or modifying this product not in accordance with the manufacturers specification then this declaration will lose its validity.</p> <p>Authorised Representative: Panasonic Testing Centre Panasonic Marketing Europe GmbH Winsbergring 15, 22525 Hamburg, Germany</p>
R	YA-HDA801R** YA-HDA201R**	YA-1WC801R** YA-1WC201R**	<p>Standard model for the American market.</p> <p>Notice: Exporting the machine into EU nations This product does not meet the requirements specified in the EC Directives which are the EU safety ordinance. Please bear in mind that this product may not be brought as is into the EU. The same restriction also applies to any country which has signed the EEA accord.</p> <p>Please be absolutely sure to consult with us before attempting to relocate or resell this product to or in any EU member state or any other country which has signed the EEA accord.</p> <p>The installation shall be made by qualified installation personnel and should conform to all national and local codes.</p>

"**": Represent the two alphanumeric characters of Model and Code numbers, which vary with specifications.





◆ Table of Contents

Introduction	2	6.1.4 Protective stop 1 input.....	32
1. Safety Precautions	5	6.1.5 Protective stop 2 input.....	32
1.1 Observe the following for safe welding operation.....	5	6.1.6 External Dead Man's input	32
1.2 Observe the following for safe robot operation.....	7	6.1.7 Input of the safety circuit	33
2. Specifications	8	6.1.8 Emergency stop output.....	34
2.1 Technical data	8	6.2 Other safety input/output	36
2.1.1 Structure and control method	8	6.2.1 Safety holder input.....	36
2.2 Dimensions.....	9	6.2.2 Installation input.....	36
2.3 Inputs, outputs and communications .	9	7. External Control Signal Connection 37	
2.4 Specifications of built-in welding power source	10	7.1 Terminal location of the sequencer card 37	
2.5 About static characteristic.....	11	7.2 Serial interface	38
2.6 Teach Pendant	12	7.3 I/O terminal equivalent circuit	39
2.7 Operation Box	13	7.4 Auto start settings	40
2.8 Controller accessories	14	7.5 Status IN/OUT	40
3. Transportation	15	7.5.1 Status INPUT.....	40
3.1 Transportation methods.....	15	7.5.2 Status OUTPUT.....	41
4. Installation	16	7.5.3 Status I/O to be allocated to user terminals	41
4.1 Choosing an installation site	16	7.6 Flowchart of Status Outputs	42
4.2 Installation site.....	16	7.6.1 Operating and Holding output.....	42
5. Connection	18	7.6.2 Mode change (I/O monitor).....	42
5.1 Connecting the controller to the manipulator	18	7.6.3 Emergency stop 1.....	43
5.1.1 Connecting cable for the manipulator.....	18	7.6.4 Emergency stop 2.....	43
5.1.2 Connecting cables for the built-in welding power source.....	19	7.6.5 Error output.....	44
5.1.3 Notes on using multiple robots	19	7.7 Connecting to the sequencer card	44
5.2 Connecting teach pendant	20	7.8 External interface, External memory ...	45
5.3 Connection of ground cable	21	7.8.1 SD Memory Card slot (Teach Pendant)	45
5.3.1 Grounding.....	21	7.8.2 USB port.....	45
5.3.2 Connection of grounding cable.....	21	7.8.3 SD Memory Card slot (Main CPU card)	45
5.4 Connecting primary power source	22	7.9 Welding voltage/current monitor	46
5.4.1 Wiring primary power cable.....	22	8. Motor Brake Manual Release Switch 47	
5.4.2 Wiring primary cables (For T*/Y* specification)	23	8.1 How to release motor brake.....	47
5.4.3 Wiring primary cables (For E*/R* specification)	24	9. Maintenance and Inspection	48
5.4.4 Using at 220 VAC (For T*/Y* specification)	24	9.1 Inspection schedule	48
5.4.5 Door handle	26	9.2 Daily check.....	49
5.4.6 Lock switches with padlock	27	9.3 Periodical check	50
5.5 Connecting to external device	28	9.4 Warnings for withstand voltage test and insulation resistance measurement	51
5.5.1 Connecting to external device	28	10. Disposal of this product	52
5.6 Using noise filter unit	29	11. Repair Parts List	53
6. Safety I/O Specifications	30	11.1 Robot controller.....	53
6.1 I/O for safety circuit	30	11.2 Teach pendant	56
6.1.1 Spare emergency stop input.....	30	11.3 Operation Box.....	58
6.1.2 External emergency stop input.....	31	12. Critical Raw Material (CRM) List ...	59
6.1.3 Door stop input	31	13. Circuit Diagram	60
		13.1 Controller 1.....	60
		13.2 Controller 2.....	61
		13.3 Welding power source	62
		13.4 For YA-1WC201***	63
		14. Labels	64
		14.1 Label locations.....	64
		14.2 Label details.....	66

1. Safety Precautions

In addition to this section, read the "Safety Manual" supplied with the robot. Also read "Operating Instructions" supplied with peripheral equipment.

◆ Signal Words and Safety Symbols

Signal Words		Safety Symbols	
 WARNING	Indicates a potentially hazardous situation, which, if not avoided, could result in death or serious injury.		Indicates a prohibited action.
 CAUTION	Indicates a potentially hazardous situation, which, if not avoided, could result in minor injury or property damage.		Indicates a mandatory action.
			Indicates a hazard alert.

1.1 Observe the following for safe welding operation.

 **WARNING**

Welding Power Unit

 **Observe the following cautions to prevent accidents that can cause serious injuries.**

- (1) It is very important to comply with all instructions, safety warnings, cautions and notes mentioned. Failure to do so can result in serious injury or even death.
- (2) Never use the welding power unit for other than welding purpose, such as for pipe thawing.
- (3) Work of driving source at the input side, selecting work site, handling, storage and piping of high pressure gas, storage of welded products and also disposal of waste should be performed according to the operating instructions and national, state and local codes and regulations.
- (4) Prevent any unauthorized personnel from entering in and around the welding work area.
- (5) Only educated and/or skilled persons who well understand this welding power unit should install, operate, maintain and repair the unit.
- (6) Only educated and/or skilled persons who well understand the operating instructions of the unit and who are capable of safe handling should perform operation of the unit.

Against Electric Shock

 **Observe the following instructions to prevent electric shock.**

- (1) Only educated and/or skilled persons should perform grounding of the case of the welding power unit, the base metal and jigs electrically connected to the base metal.
- (2) Before installation or maintenance work of the welding power unit, turn off all input power including power at the power distribution box and wait for at least five minutes to discharge electrical current from the capacitors. Check to make sure that no charged voltage present at capacitors before touching any parts.
- (3) Do not use undersized, worn, damaged or bare wired cables.

- (4) Connect cables firm and insulate the connected parts.
- (5) Do not use the product with a case and panel removed or not in place.
- (6) Do not handle the welding power unit with torn or wet gloves.
- (7) Wear safety harness in case of working above floor level.
- (8) Perform periodic checks without fail. Repair or replace any damaged parts as needed prior to use.
- (9) Turn off all equipment when not in use.
- (10) Do not touch any live parts.
- (11) The welding power unit must be grounded and the work must be grounded in accordance with ANSI Z49.1 (For North America).

Electromagnetic Wave

 **Observe the following cautions to prevent radio interference due to welding current and high frequency for arc start.**

- (1) Electromagnetic wave generated during welding operation may have adverse affects on medical equipment in the periphery of the equipment in operation and the welding work site. If you wear a pacemaker, consult your physician before going near the welding work site.
- (2) Provide proper grounding work of all equipment including electronic devices and safety devices near the welding work site. Conduct an additional electromagnetic shielding work if needed.
- (3) Lay the welding cable as short as and as close to the floor or ground as possible. Lay the base metal cable and the torch cable along to each other to reduce generation of electromagnetic wave.
- (4) Never share the ground work of the base metal and welding power unit with other equipment.
- (5) Provide measures against noise to the external equipment, such as sequencer of the jig, proximity switch and area sensor, if such equipment is affected by the inverter noise from the robot or welding power unit. For details of the measures, please refer to the operating instructions of the external equipment.

WARNING

Ventilation and Protective Equipment



Oxygen deficit, fume and gas generated during welding can be hazardous.

- (1) Provide sufficient ventilation or wear breathing equipment specified by the applicable law (occupational safety and health regulation, ordinance on the prevention of oxygen deficiency and the like).
- (2) To prevent dust injury or poisoning by the fume generated during welding, use a local exhauster specified by the applicable law (occupational safety and health regulation, rules on preventing injury by inhaled dust or etc.) or wear a protective breathing gear. If a protective breathing gear is used, it is recommended to use one with an electric fan with high protection performance.
- (3) When conducting welding in the bottom, such as tank, boiler and the hold of a ship, use a local exhauster or wear breathing equipment specified by the applicable laws and regulations.
- (4) When conducting welding in a confined area, make sure to provide sufficient ventilation or wear breathing equipment and have a trained supervisor observe the workers.
- (5) Do not conduct welding at a site where degreasing, cleaning or spraying is performed. Conducting welding near the area where any of these types of work is performed can generate toxic gases.
- (6) When welding a coated steel plate, provide sufficient ventilation or wear protective breathing gear. (Welding of coated steel plates generates toxic fume and gas.)
- (7) Never ventilates with oxygen. Refer to ANSI Z49.1 (For North America).

Against Fire, Explosion or Blowout



Observe the following cautions to prevent fires explosion or blowout.

- (1) Remove any flammable materials at and near the work site to prevent exposure of such flammable materials to the spatter. If they cannot be relocated, cover them with a fireproofing cover.
- (2) Do not conduct welding near flammable gases. Do not place the electric equipment near flammable gases, otherwise, such gases may catch fire from a spark of electricity inside the electric equipment.
- (3) Do not bring the hot base metal near flammable materials immediately after welding.
- (4) When welding a ceiling, floor or wall, remove all flammables including ones located in hidden places.
- (5) Connect cables firm and insulate the connected parts. Improper cable connections or touching of cables to any electric current passage of the base metal, such as steel beam, can cause fire.
- (6) Connect the base metal cable as close as possible to the welding section.
- (7) Do not weld a sealed tank or a pipe that contains gas.
- (8) Keep a fire extinguisher near the welding site for an emergency.

No Disassembling/Modification



Unauthorized disassembling or modification can cause fire, electric shock or breakdown.

- (1) Contact Panasonic sales representatives for repair work.
- (2) As for inspection of the inside the product if needed, follow the instructions in the operating instructions.

CAUTION

Installing Shielding (Curtain etc.)



Arc flash, flying spatter and slugs generated during welding can damage your eyes, skin and hearing.

- (1) When welding or monitoring welding operation, wear safety glasses with sufficient light blocking structure or use a protective mask designed for welding operation.
- (2) When welding or monitoring welding operation, wear protective clothing designed for welding operation, such as leather gloves, leg cover and leather apron, and also wear long-sleeve shirts.
- (3) Install a protective curtain around the welding operation site to prevent exposure of eyes of people in the surrounding area to the arc flash.
- (4) Be sure to wear noise-proof protective equipment, such as ear muffs and ear plugs, if the noise level is high.

Gas Cylinder and Gas Flow Regulator



Overturn of gas cylinder and blowout of gas flow regulator can cause injury.

- (1) The gas cylinder must be handled properly according to the applicable law and in-house standards.
- (2) Use the gas flow regulator that is supplied or recommended by our company.
- (3) Read the operating instructions of the gas regulator prior to use, and observe the cautions described in it.

- (4) Secure the gas cylinder to a dedicated gas cylinder stand.
- (5) Do not expose the gas cylinder to high temperature.
- (6) When opening the valve of the gas cylinder, do not bring your face close to the discharge outlet.
- (7) When the gas cylinder is not in use, be sure to put the protective cap back on.
- (8) Do not hang the welding torch on the gas cylinder. Do not allow the electrode to touch to the gas cylinder.
- (9) Only the specified contractor should perform disassembly or repair work on the gas flow regulator. Such works require some expertise.

Rotating Parts



Rotating parts can cause injury.

- (1) Keep away from rotating parts, such as cooling fans and feed rollers of the wire feeder, or hand, finger(s), hair or part of your clothes may be caught by the rotating parts resulting in injury.
- (2) Do not use the product with a case and panel removed or not in place.
- (3) Only educated and/or skilled persons who well understand welding machines should perform maintenance and repair work. During maintenance or repair work, provide fence or the like around the welding machine so that any unauthorized person can not come close to the working area carelessly.

 **CAUTION**

Welding Wire

	Welding wire, especially wire tip part can cause injury.
---	---

- (1) Do not perform inching operation or press the torch switch with your eyes, face or body close to the end of the welding torch. Wire extends out from the end of the welding torch and may stick into the eye, face or body.
- (2) In case of using a torch cable with the resin liner, straighten the torch cable and reduce the preset feed amount (current) to half or less before applying the wire inching.
- (3) If the high speed wire inching is executed with the torch cable extremely-bent, the welding wire may pass through the resin liner and the cable.
Replace any damaged liner/cable with a new one without fail. Never use a damaged liner/cable, or it can cause gas leak or insulation deterioration.

Against Insulation Deterioration

	Insulation deterioration can cause fire of welding power unit.
---	---

- (1) Keep enough distance from welding power unit when performing welding or grinding operation so as to prevent such spatters or iron particles from getting into the power unit.
- (2) Perform inspection and maintenance work periodically so as to prevent insulation deterioration due to accumulated dust or dirt.
- (3) When spatters or iron particles get into the welding power unit, turn off the power switches of the welding power unit and power distribution box, and then use dry air to blow them off.

1.2 Observe the following for safe robot operation.

 **WARNING**

Robot

	Observe the following for safe robot operation
---	---

- (1) The product is delivered in emergency stop state.
(Open Installation input) Confirm total safety of robot system and then short-circuit the external emergency stop input after the completion of the installation and start-up of the system.
- (2) Be careful of the arm downward motion when you release a motor brake. The robot arm will descend under its own weight if a motor brake is released, which can cause personal injury or damage to a device. Prior to releasing a brake, take measures not to descend the arm or check to confirm that no personnel or no device that may be damaged exists.
- (3) Check to confirm that no personnel are present within the robot work envelope before turning on the power.

2. Specifications

2.1 Technical data

2.1.1 Structure and control method

Item	Specifications	
Structure and IP class	Closed box type, IP32 or equivalent	
Cooling method	Indirect air cooling (Circulating internal air), Direct air cooling (Welding power supply)	
Input power source	3-phase, 200 VAC \pm 20 VAC, 22 kVA(20 kW), 50/60 Hz (T/Y specifications only: Switchable to 220 VAC.)	
Maximum power	<ul style="list-style-type: none"> • During welding: Max. 22 kVA (20 kW) • During servo ON: Max. 370 A/2 ms 	
Grounding	Protective Earth (PE) grounding is required. Functional Earth (FE) is required depending on applied system. Note) For Power capacity, see section "Connection".	
Earth leakage current	Less than 17 mA	
Body color	Munsell color system 5Y8/1	
Teaching method	Teaching playback	
Path control	PTP and CP (Linear and circular interpolation)	
The number of control axes	6 axes simultaneously (Max. 27 axes)	
The number of external axes	Limiting to manipulator + 6 external axes (Total motor capacity: 20 kW or less) (Built-in type External Axis Controllers is not supported.)	
Position detection method	Electronic type absolute pulse encoder	
Position control method	Software servo control	
Speed control method	Constant linear velocity control (during CP control)	
Speed range	in teaching operation	Max. speed can be controlled within the safety speed range from 0.01 m/min to 15 m/min (Default setting: 15 m/min)
	in playback operation	0.01 m/min to 180 m/min (Direct input method)
Memory system	IC memory (Battery back-up system)	
Memory capacity and software	See the operating instructions "Operation"	
Connecting cable	<ul style="list-style-type: none"> • Supplied with manipulator for fixed wiring • Length: 7 m, Diameter: 26 mm, Bend radius: 182 mm or more 	
Dimensions (W x D x H)	553 mm x 600 mm x 1 181 mm (Protruding portions not included.)	
Operating ambient temperature, humidity	0 to 40 °C, 20 to 90 %RH (50 % RH or less at 40 °C, and 90 %RH or less at 20 °C.) No due condensation	
Transportation / Storage temperature	-25 °C to 60°C	
Mass (Weight)	163 kg (360 lb), (Excluding the Teach pendant and connecting cable.)	

Note

For software specifications, see "Operating Instructions [Operation]".

2.2 Dimensions

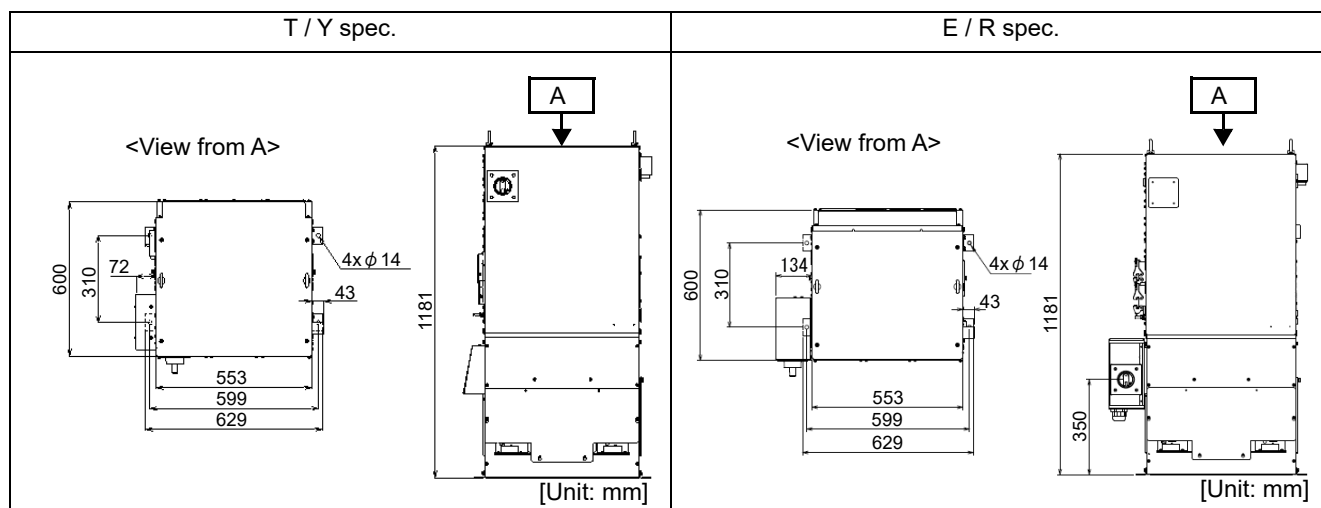

2.3 Inputs, outputs and communications

Items	Input and output	Specifications
Status I/O	Input	Start Error release Operating mode
	Output	Hold Teaching mode Servo ON
Common I/O	Input	Running
	Output	Hold status Operating mode Servo ON Alarm
	I/O allocation	40 points (Option: expandable to max. 2 048 points)
Other I/O	Input	40 points (Option: expandable to max. 2 048 points)
	Input specs.	Program select input, other status I/O.
	Output specs.	Safety Holder input and Installation input
Safety circuit	Dual circuit input	Photo-coupler (ON/OFF of 24 VDC, 12 mA)
		Open Collector
	Output	Open emitter
		Emergency stop for Teach Pendant
		Emergency stop output (system 4)
Input specs.	Spare emergency stop	
Output specs.	External emergency stop	
External memory, Communication Interface	Controller	Emergency stop Door stop Deadman switch External deadman switch Panel emergency stop ^(*) Protective stop
	Teach Pendant	Double contacts (Dual circuit)
		Double contacts (Dual circuit)
		Optional RS-232C, RS-422 and Ethernet ^(*)
		SD memory card slot
		USB2.0 (Hi-Speed not supported): 2 ports ^(*)

Note

Manipulator is not included in this product. Although some setting items/commands for the manipulator are displayed on the screen of the teach pendant while operating the teach pendant, those setting items or commands are not available.

^(*): For controllers of E and R specifications, it is factory connected to the “Emergency stop” of the operation box (standard accessory).

^(*): Connect only with LAN in the plant.

^(*): Do not turn off the power switch while connecting with SD memory or USB memory.

2.4 Specifications of built-in welding power source

Item	Specifications
Built-in welding power source type	YA-1TD351T00
Welding process	CO ₂ , MAG, Stainless steel MIG, Pulsed MAG/MIG
Control method	Inverter
Max. no-load voltage	65 VDC
Output current adjustable range	30 - 350 ADC
Output voltage adjustable range	12 - 36 VDC
Rated duty cycle (10 min interval)	80 % for GMAW and 60 % for pulsed GMAW
Output terminal	Connection with M6 bolt and nut
Insulation level	Main transformer: Class F, Reactor: Class E, Power factor improvement reactor: Class H.
Mass (Weight)	48 kg (106 lb)
Power efficiency	82 %
Standby power consumption	10 W (welding power source only)
Equivalent models	None
Shield gas index at MAG welding	350 A: 20 L/min
Wire use rate	350 A: 134 g/min

Note About "Duty cycle"

Duty cycles are based on a ten minutes time interval. If the duty cycle is 80 % at rated output. That means for 80 percent of the ten-minute period (8 minutes), the power source can maintain operation at the rated welding current without overheating. The remaining two minutes must be operated at no-load to allow proper cooling. (8 min. / 10 min.) x 100 = 80 (%)

Using the machine at beyond the rated duty cycle causes rise in temperature of the machine beyond the max. allowable temperature, and deterioration or burning of the machine may be the result.

In case of using the machine in combination with other products, such as welding torch, please apply the lowest rated duty cycle among the applied products.

Duty cycle at 40 °C is calculated based on simulations.

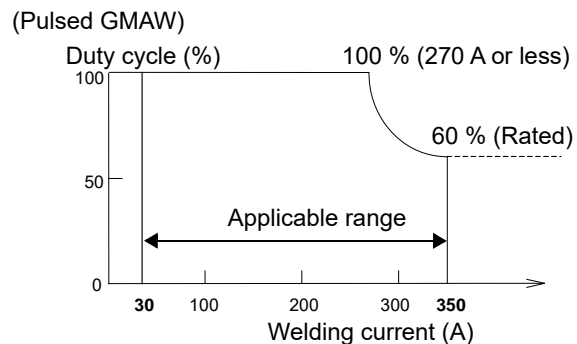
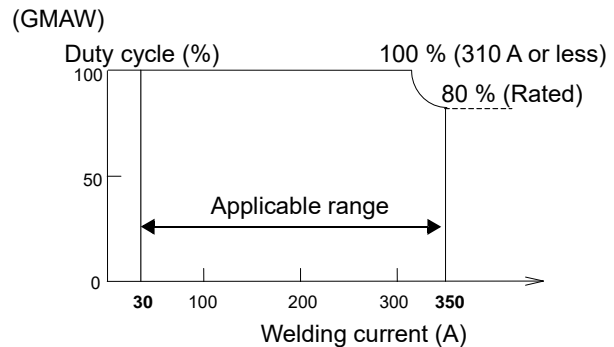

2.5 About static characteristic

The static characteristic of this welding power source is the following constant voltage characteristic.

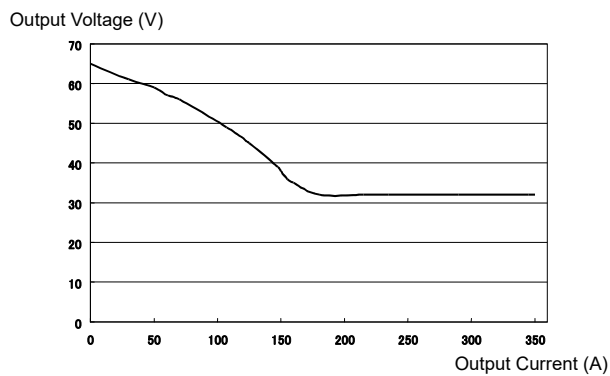

- Thermal protection

The welding power source is equipped with thermal switch at the radiator fin of the semiconductor to monitor the temperature.

The thermal switch is turned on and stops the output when the welding power source becomes an abnormal elevation of temperature due to over-duty cycle or over-rated output current, or declining cooling effect.

Specifications

2.6 Teach Pendant

Item	Specifications
Model number	AUR01060
Environmental protection class	IP42 or equivalent
Display	7 inches wide TFT color graphic LCD
Memory in TP	IC memory
SD memory card slot	1 slot
USB 2.0 port	2 (Hi-Speed: not supported), Bus power: 150 mA
Deadman switch	3 points action
Emergency stop switch	1 (Mechanical self-hold type)
Connecting cable	10 m
Mass (Weight)	988.5 g (Cables not included.)

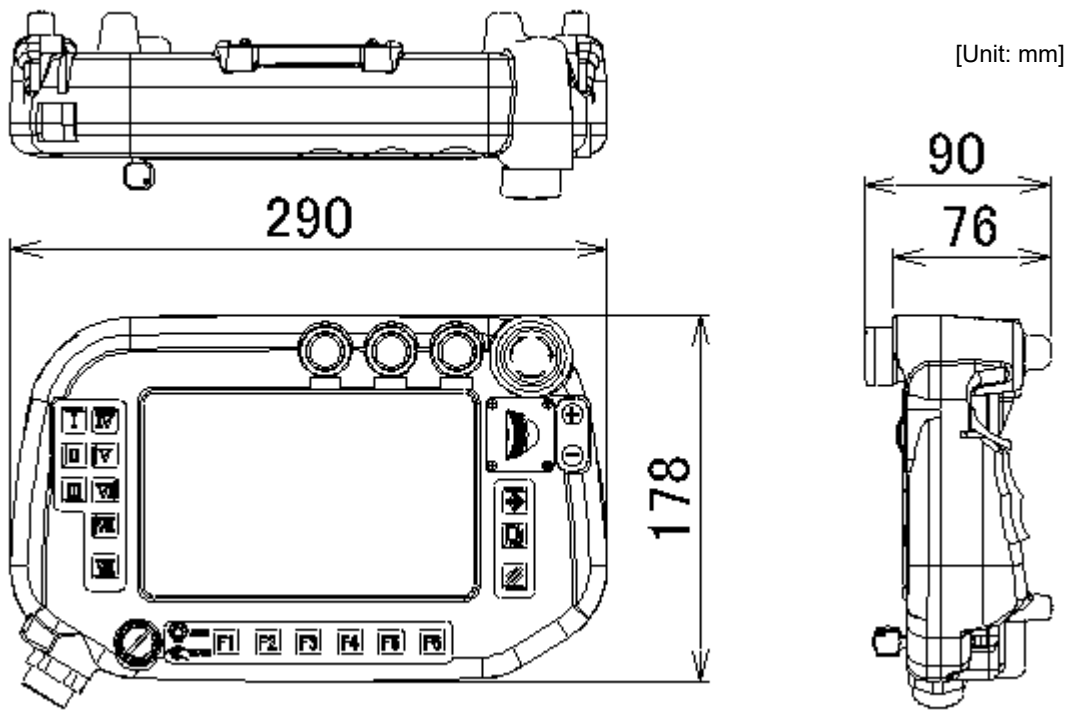

CAUTION

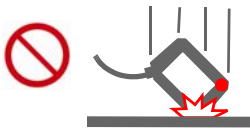

Careful not to drop the teach pendant.
Or it may result in teach pendant damage and/or injury.



Do not place anything on the teach pendant.
Do not apply any strong force or impact especially on the LCD part.
Or it may result in damage of teach pendant and LCD.



Do not pick up or handle the teach pendant by the cable or the connector part.
Hold the teach pendant by the body at any time.
Or excess load will be applied to the connection, which can damage the teach pendant.

2.7 Operation Box

T / Y spec.	Optional
E / R spec.	Standard

Item	Specifications
Environmental protection class	IP40 or equivalent
“AUTO mode” switch	1 (Connect to the “PNL” connector of the sequencer card.)
Emergency stop switch	1 (Mechanical self-holding type. Connect to the “PNL” connector of the safety card.)
Software	If the operation box is purchased as an optional unit, the initial setup by our service engineer is needed.
Connecting cable	6 m

The “AUTO” mode operation is functioned by

- (1) Changing the Mode switch of the Teach Pendant to “AUTO”
- or
- (2) Restarting after door stop input in “AUTO” mode, and then the “AUTO mode” button of the Operation Box is pressed.

● Location of PNL connector

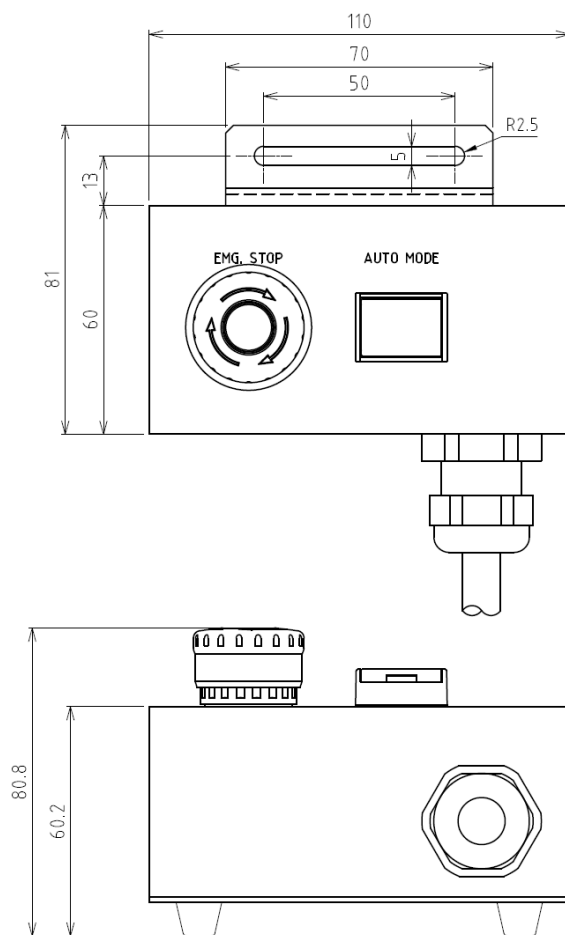
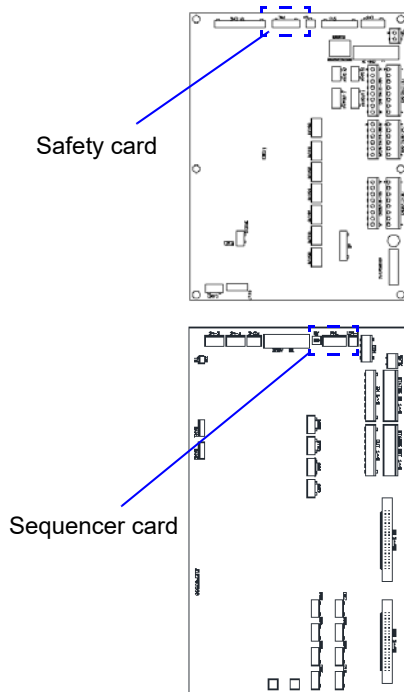

[Unit: mm]

Note

- Depending on the model numbers, the operation box is factory connected at shipment.
- If not connected, the “PNL” terminal of the safety card is factory short-circuited at shipment.

Specifications

2.8 Controller accessories

Description	Part number	Repair parts order number	Q'ty	Note	Safety part
TP hook	AKC41237	AKC41237	1	For Teach Pendant	
Ball chain (*)	TM14-1L500	YAB47	1		
Mode select switch key (*)	AS6-SK-132	YAB178	1 set	2 pcs/set	
Fuse (12 A anti-rush type)	CES14-12AN2	YABD264	1		Yes
Fuse (8 A anti-rush type)	ST4-8AN1	YZAD217	2		Yes
Fuse (5 A anti-rush type)	ST4-5AN1	YZAD183	1		Yes
Fuse (3 A anti-rush type)	ST4-3AN1	YZA/EEJ002	5		Yes
Fuse (2 A anti-rush type)	ST4-2AN1	YZAD181	1		Yes
Fuse (0.5 A anti-rush type)	ST4-0.5A	YZAD179	2		Yes
Fastener key (For the front door lock)	(Fastener attachment)	-	2		
Connector (For the Sequencer card)	FCN361J040AU	FCN361J040AU	2		
Connector cover (For the Sequencer card)	FCN360C040B	FCN360C040B	2		
Harness (For external emergency stop and door stop)	AWC42038	AWC42038	4		
Label for Key switch (Sheet type)	ANS31017	ANS31017	1	Delivered in a plastic bag and tape it to the rear side of the teach pendant.	
Labels:(Matchmarks for origin)	ANU51519	ANU51519	1		
Terminal labels (For "User I/O")	ANS41119	ANS41119	1		
Saddle	SP30	SP30	1		
Rubber sheet	AFQ41158	AFQ41158	1		
Bolt	XVGZ8+F25FJ	YZA239	2		
Washer	XWE8FJ	YZA225	2		
Nut	XNG8GFJ	YZA198	2		
Noise suppression parts	Clamp filter	J0KG00000014	YABD125	1	
	Nylon tie	AB150	YAW87	1	
	Tie fixture	TMS20	YWW39	1	

(*): They are fitted with the TP hook.

Note

Safety parts are important for safe machine operation. Always use correct parts in correct locations.

3. Transportation

3.1 Transportation methods



CAUTION

When using a crane, be sure not to stand under or near the lifted controller.
When using forklift, be sure no personnel shall hold the controller.

Any transportation method that may apply any shock to the controller shall be avoided.

- (1) Crane or forklift should be handled by qualified personnel.
- (2) In principle, use a crane to transport a robot controller for installation or re-installation. When a crane is used, hang the robot controller with double-wire through the attached two eyebolts as illustrated in the figure on the right.
 - Double-wire hanging method.
Hook the wires to the provided eyebolts.

About eyebolts

Eyebolts are important safety parts. When they are lost or broken, purchase Panasonic genuine eyebolts for your safety.

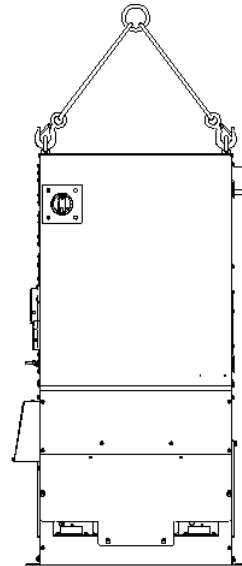

- (3) In case it is necessary to use folk lift for transportation, pack and fix the controller in the transportation package before moving it.

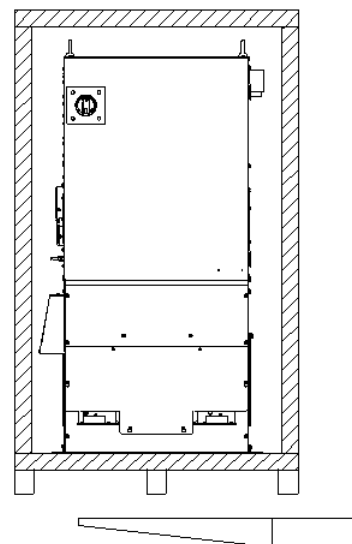

4. Installation



CAUTION

The installation shall be made by qualified installation personnel and should conform to all national and local codes.

4.1 Choosing an installation site

- Locate indoors with ambient temperature 0 °C to 40 °C.
- Avoid exposure to direct sun light or the rain or water spray.
- Humidity relative to temperature:
 - Up to 50 % at 40 °C
 - Up to 90 % at 20 °C
- Altitude above sea level: Up to 1000 m.
- Inclination to installation surface: Max. 10 degrees.
- Avoid wind to the arc (Provide windshields.)
- Free from abnormal amount of dust, acid, corrosive gases or substances etc. other than those generated by welding process.
- Avoid places where metallic substances or combustible foreign materials can get into the welder through the air inlets.

- IP code

Part	IP code
Controller body	IP32 or equivalent
Teach pendant	IP42 or equivalent
Operation Box	IP40 or equivalent

Note

- If a significant noise source (plasma or high frequency etc.) exists at or around the installation site, please consult us in advance.
- Refer to the environmental protection class (IP class) of each machine. (See “Specifications”).

4.2 Installation site

- (1) Locate the controller outside of the work envelope of a manipulator and also outside the safety fenced area. Make sure to maintain space from any wall or peripheral equipment (see the figure on the right) from any wall or peripheral equipment for maintenance and inspection work and to control temperature inside of the controller.

Note: Do not place anything above and below the controller unless otherwise specified.

If places, an abnormal temperature error may occur due to increase in temperature inside the controller.

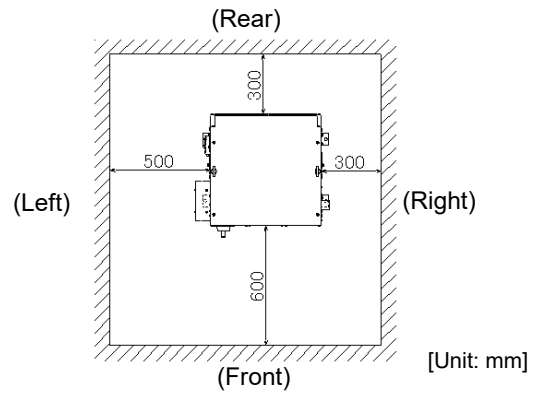

< E / R spec. >

Set a bedplate under the controller to give the controller lift from the floor so that the breaker is positioned at 600 mm or more above the floor.

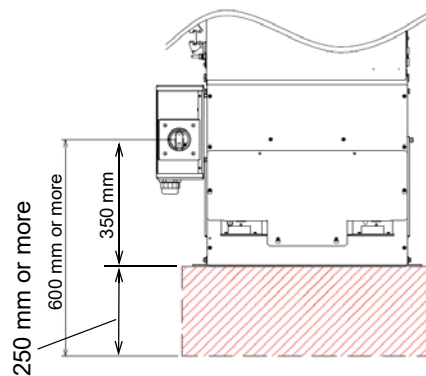

(2) Installation method

Fix the fixing plates of the controller to the ground or bedplate with M12 anchor bolts.

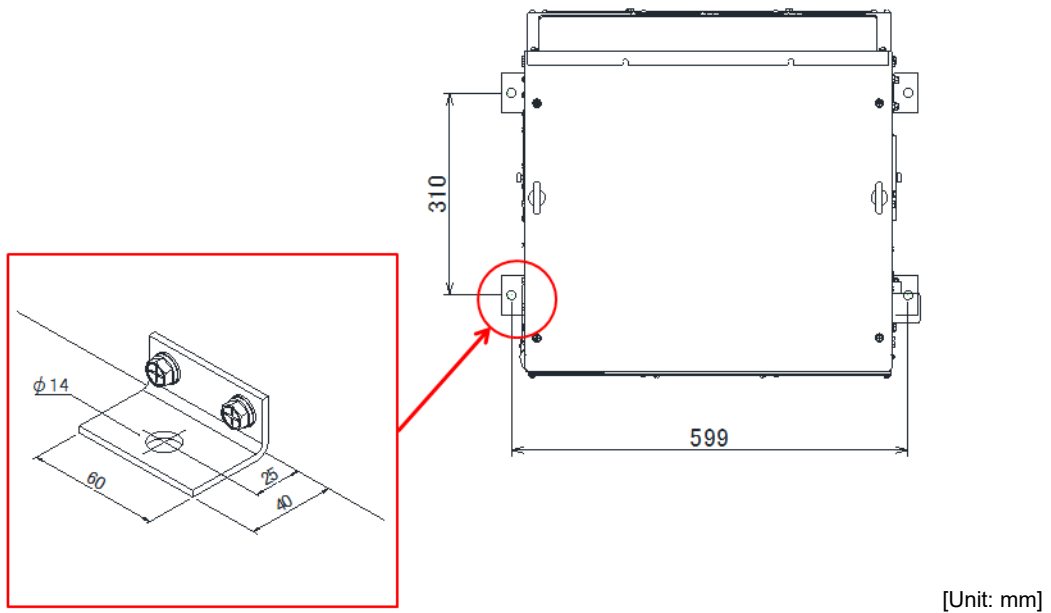

(3) Teach pendant

Hook the teach pendant on the provided TP hook. TP hook should be installed outside of both the safety fence and the work envelope of the manipulator so as to prevent possible danger due to mode change inside the safety fenced area. A mode switch key is chained with ball chain to the TP hook. Length of the cable between the teach pendant and the controller is 10 m.

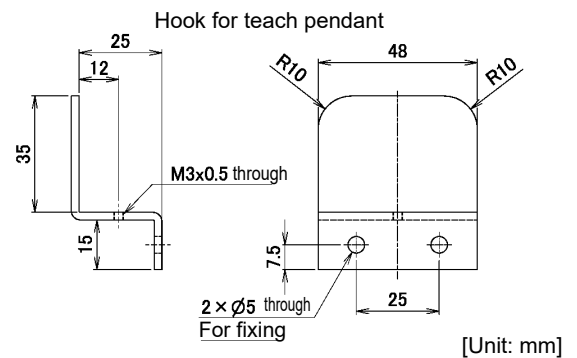

(4) Operation box

T/Y spec.	Optional
E/R spec.	Standard

The panel fixture is provided with the operation box to station the operation box during operation or to store it. To use the panel fixture, please prepare a hook at customers' end. Make sure to locate it outside of the work envelope of a manipulator and also outside the safety fenced area. It shall be placed where the operator can check inside of safe guard area easily. Length of the cable between the operation box and the controller is 6 m.

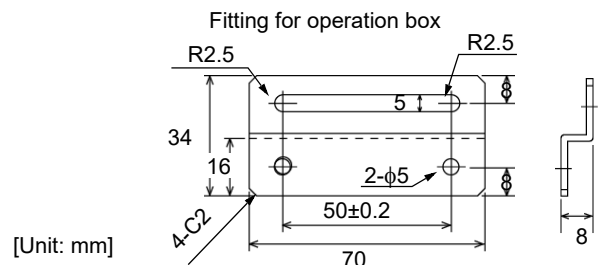

5. Connection

WARNING

The installation shall be made by qualified installation personnel and should conform to all national and local codes.

5.1 Connecting the controller to the manipulator

5.1.1 Connecting cable for the manipulator

- (1) Connect the motor cable and RE cable to the connectors for controller and manipulator respectively. Make sure to push the cables until the gap between the connector and cable connector case becomes 1 mm or less.

< Note >

Wide gap between the plug and the receptacle may cause bent pin of the connector.

- (2) Push down the hook lever to the arrow direction and lock the plug.

Note

- The controller remembers manipulator origin data (robot position control origin). Be sure to connect the controller to the manipulator whose serial number is shown on the plate on the front of the controller.
- The connection cable is supplied with the manipulator.

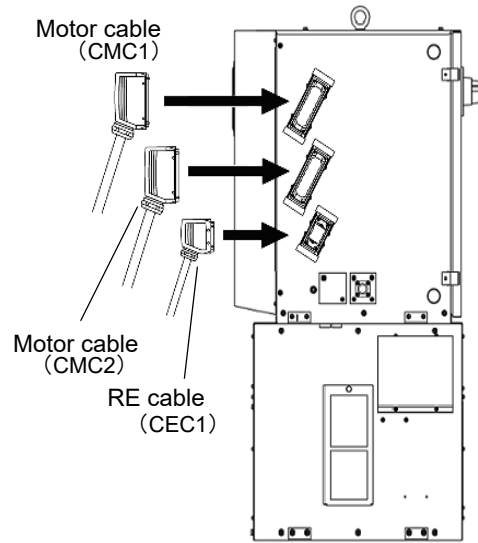

Connector

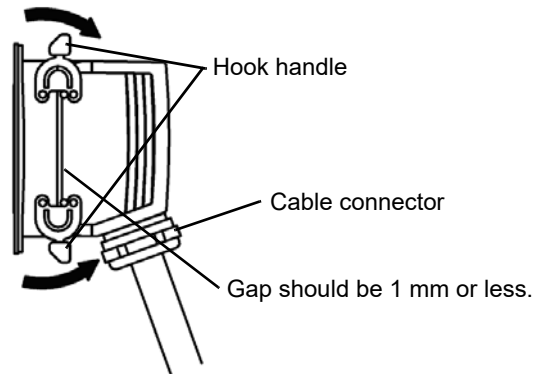

5.1.2 Connecting cables for the built-in welding power source

- (1) Connect the output cable (customer preparation) from welding power source to the output terminal (-) for "BASE METAL" with attached M8 bolt. (Recommended clamping torque: 10.1 N•m-13.4 N•m)
- (2) Connect the welding power cable to the output terminal (+) for "TORCH" with the attached M8 bolt. (Recommended clamping torque: 10.1 N•m-13.4 N•m)
- (3) Connect the base metal voltage detection cable (-) to the voltage detection terminal on the left side of the output terminal (-) for "BASE METAL" terminal.
- (4) Re-install the output terminal cover back in place.

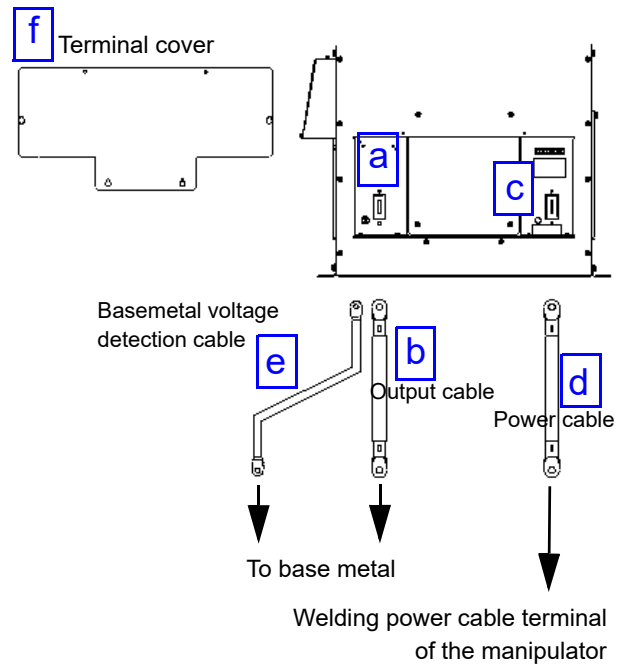

No.	Name	Remarks
a	Output (-)	For base metal Bore diameter: 10.5 mm Connect with the provided M8 bolt.
b	Output cable	*Customer preparation article
c	Output (+)	For welding torch Bore diameter: 10.5 mm Connect with the provided M8 bolt.
d	Power cable*1	5 m (standard)
e	Base metal *1 detection cable	10 m Bore diameter: 6 mm
f	Terminal cover	

*1: Provided as incidental equipment.

Note

- After connecting the base metal cable and the power cable, make sure to insulate the connecting part with insulating tape.
- Output cable should be a welding cable or a tough rubber shielded cable (excluding one with vinyl). The cable length should not be unnecessarily long. Treat the end of the cable with clamping terminal. Use the clamping terminal of the following size.

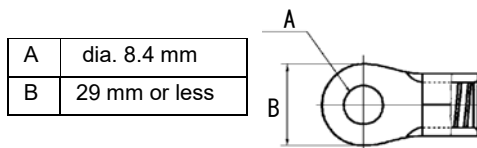

5.1.3 Notes on using multiple robots

To weld one workpiece with multiple robots, observe the following:

- Connect the work cable and voltage detection line of each robot to the closest possible portion to each weld. Be sure the distance between each robot's cable/line connection portions is 500 mm or more. (Weld output of other robots can make the weld unstable)
- Be sure the multiple robots do not share one work cable or voltage detection line.

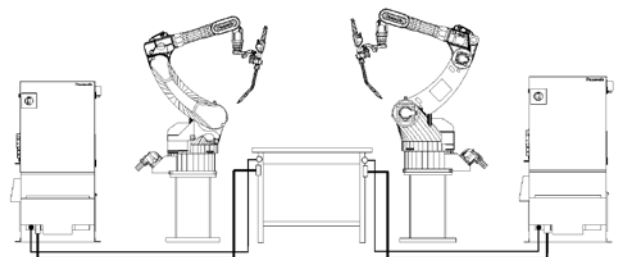

5.2 Connecting teach pendant

Note

Do not bend the TP cable near the connector and connect it to the controller. Otherwise, connecting pins may be damaged.

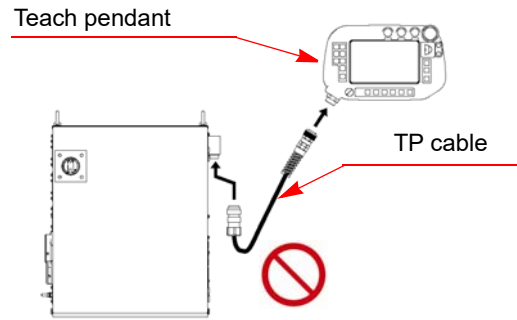

Connect the TP cable to the connector of the teach pendant.

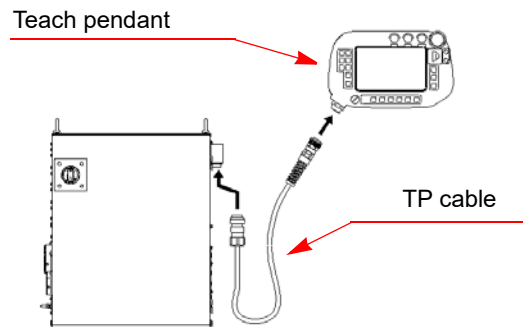

- Match the match-marks (concave) at the connector of the TP cable with the match-marks (convex) at the connector of the teach pendant, and then fasten the cable ring.

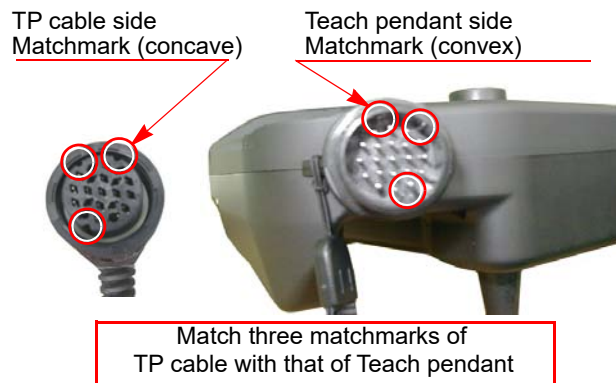

Note When fastening the cable ring

Do not fasten the ring tight at one time and forcedly. Turn the ring a little and push the cable in and repeat the procedure until the ring is set completely. Fastening the ring forcedly may cause damage or malfunction of the machine.

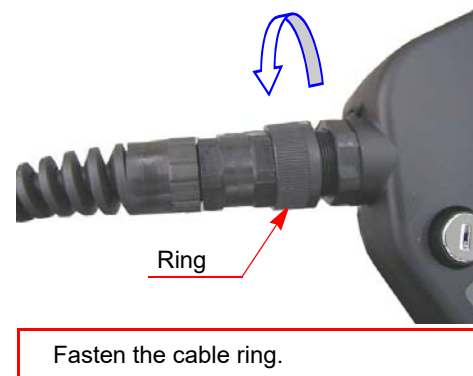

5.3 Connection of ground cable



CAUTION

Provide grounding to the protective earth terminal (PE) of the robot controller exclusively.
Check the grounding before operation.

5.3.1 Grounding

Be sure to perform grounding work. Two 14 mm² (AWG6) Green/yellow grounding wires are supplied with the manipulator as accessories.

Note

Size of the protective conductor for other devices shall be according to the corresponding instruction.

Countries	Grounding resistance	Additional protective conductor
Japan	100 ohm or less	14 mm ² or more.
EU	100 ohm or less	14 mm ² or more.
USA	0.1 ohm or less	AWG6 or more
Others	Conform to all national and local codes	

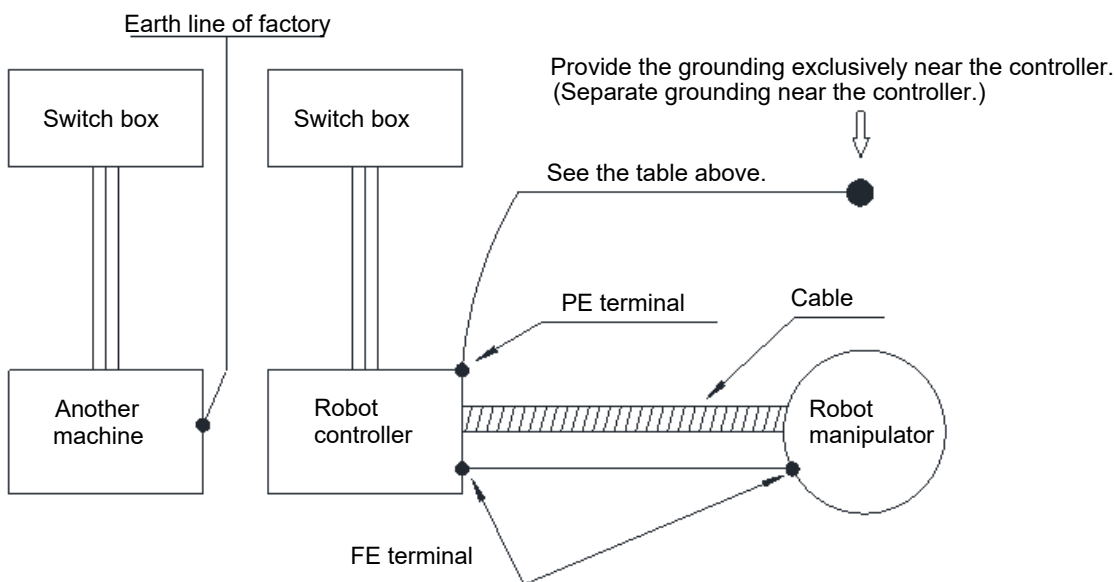

5.3.2 Connection of grounding cable

- (1) Remove the cover of the terminal box (or breaker box).
(Remove four M4 screws for T/Y specs.)
(Remove six M4 screws for E/R specs.)
- (2) Pass the protective conductor through the cord lock and then connect it to the PE terminal.
- (3) Put the cover of the terminal box back in place.

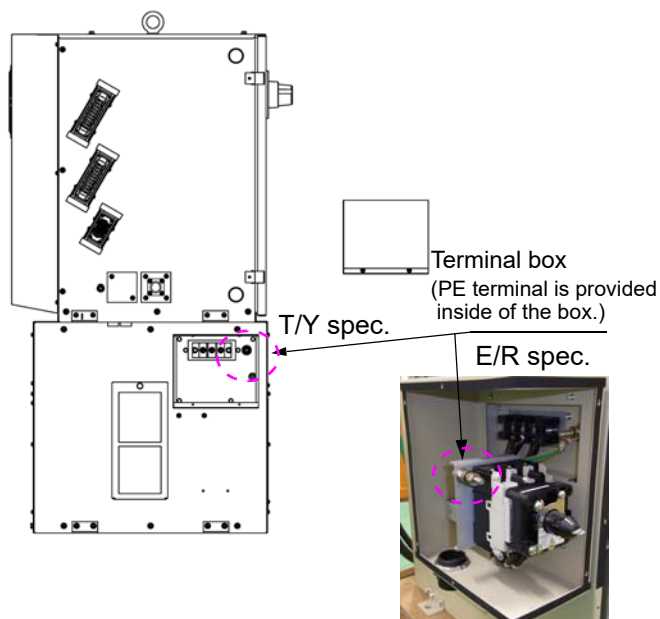

Connection

5.4 Connecting primary power source

5.4.1 Wiring primary power cable

Input power capacity	Cable size
22 kVA (20 kW)	14 mm ² or more AWG6 or more

- (1) Be sure to provide no-fuse breaker (earth leakage breaker) or switch with fuse of specified capacity for each controller separately.
- (2) To prevent noise from entering from the power cable, if it is the case, install a filter before the primary input.

Note

- Remarks on "Earth leakage breakers"
Use of earth leakage breakers with medium sensed current and high-speed type, if applied, is recommended to prevent malfunction of the breaker.
- The rated sensed current to prevent malfunction of the earth leakage breaker is about 100 mA when using a robot only and 200 mA when using an external axis together with a robot. For details and grounding work, please consult your local electrical engineers.
- To prevent noise from entering from the power cable, install a noise filter as shown in the figure.

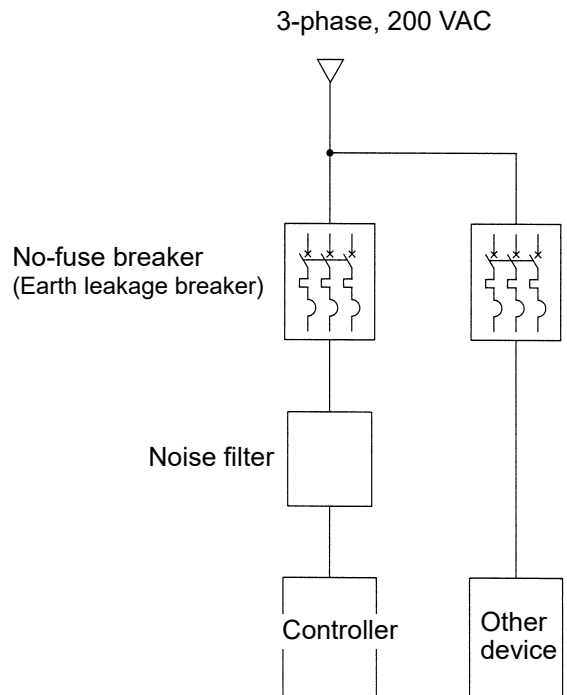

Maximum power	
During robot operation	Max. 14.3 kVA / 200 ms (Max. 22 kVA during welding)
During servo on	Max. 370 A / 2 ms

- Connecting to a power facility other than 200 VAC (For connection to a power facility of 220 VAC, please refer to section "Using at 220 VAC (For T*/Y* specification)" on page 24)
- You can use either PE or PEN as ground terminal.
- Do not use the terminal "N" of the power facility, if any.
- Please prepare a transformer to convert voltage to 200 VAC at your end.

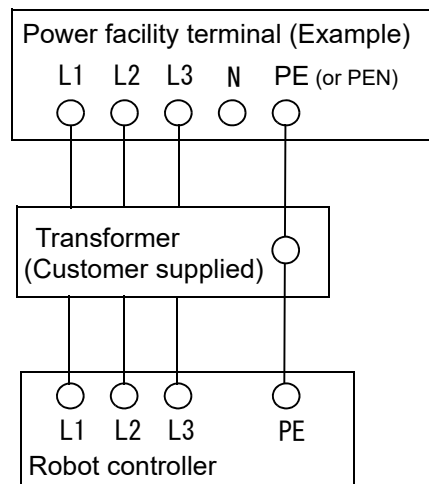

5.4.2 Wiring primary cables (For T*/Y* specification)

* Input power cable is a customer preparation item.

- (1) Remove the cover of the terminal box.
(3 screws for T/Y spec., 4 screws for E/R spec.)
Pass input cables through the cord lock and then connect it to the input terminals.

Outside diameter of cord lock adaptive cable	ϕ 24 mm-28 mm
--	--------------------

- (2) Put the cover of the terminal box back in place.
- (3) Fix the input cable with a rubber sheet and a saddle.

Note	<p>Connecting screw "A"</p> <ul style="list-style-type: none"> • Do not use a wrench • Tightening torque: 2.5 N•m to 3.0 N•m 	
-------------	--	---

Recommended terminal at "A".
(14 mm² for M6)

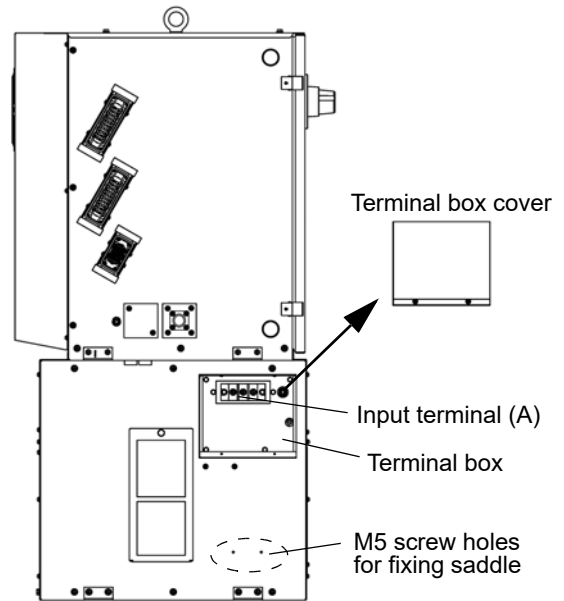
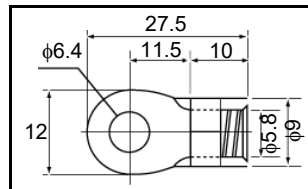

CAUTION

Do not connect a primary power cable of peripheral equipment to the breaker or terminal block inside the controller, or it will cause malfunction or breakdown.

Connection

5.4.3 Wiring primary cables (For E*/R* specification)

* the input power cable is customer preparation.

- (1) Remove the cover of the breaker box. (four M4 screws) Pass input power cables through the cord lock and then connect it to the breaker.

Outside diameter of cord lock adaptive cable	ϕ 24 mm-28 mm
--	--------------------

- (2) Protect the cable coating with the attached rubber sheet and then set the saddle over the rubber sheet to fix the cable.
Wire the input power cable carefully not to touch the edge of the plate. Keep some space between them.
- (3) Put the cover of the breaker box back in place.

Note	Connecting screw "A"	
	<ul style="list-style-type: none"> • Do not use a wrench • Tightening torque: 5.5 N·m to 7.5 N·m 	

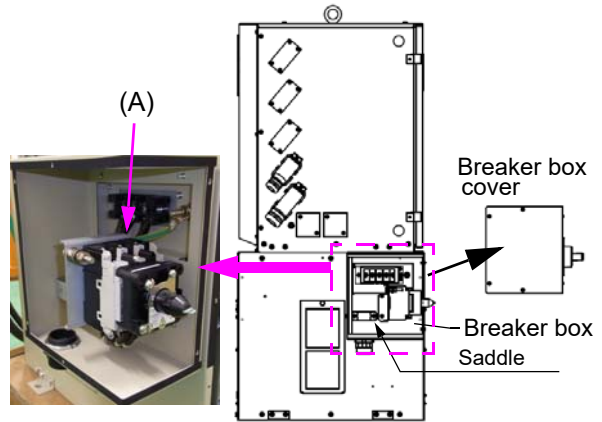

Recommended terminal at "A".
(14 mm² for M8)

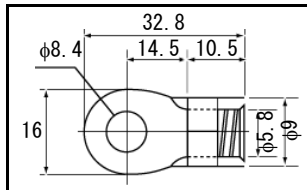

CAUTION

Do not connect a primary power cable of peripheral equipment to the breaker or terminal block inside the controller, or it will cause malfunction or breakdown.

5.4.4 Using at 220 VAC (For T*/Y* specification)

In case of using the controller at 220 VAC, it is necessary to switch the voltage of the controller and also built-in welding power source.

<How to open the rack>

- (1) Disconnect all four connectors; TPOW, TCOM, CAN0, and CAN1, from the backplane.
- (2) If the controller is WG3 specifications, disconnect three flat cables from the weld control card.

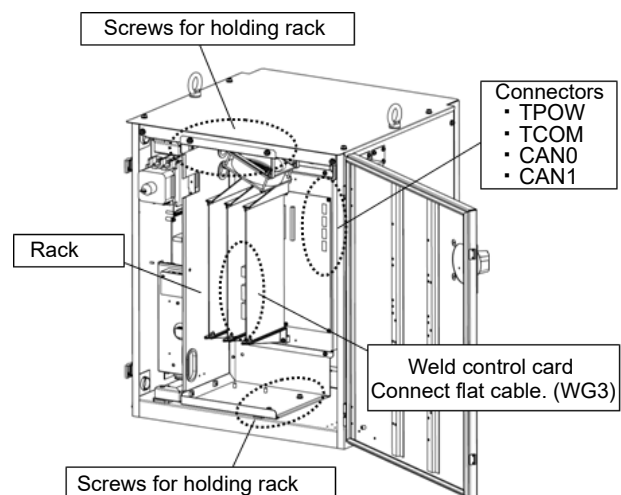

- (3) Loosen the four screws that hold the rack. Then open the rack.

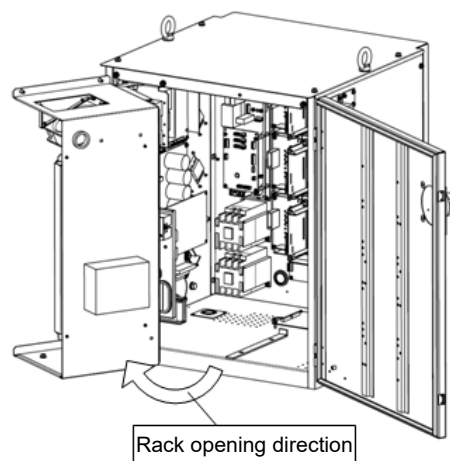

<Controller side>

- (4) Disconnect the primary side harness connector "200 VAC" of the transformer (UTU5314) located at the back of the rack of the controller from the connector "200 VAC" on the power card (ZUEP5880). Then connect it to the connector "220 VAC".
- (5) Close the rack in the reverse procedure to opening the rack. Then re-connect all connectors that have been disconnected back in place.
- (6) Connect the power cable.

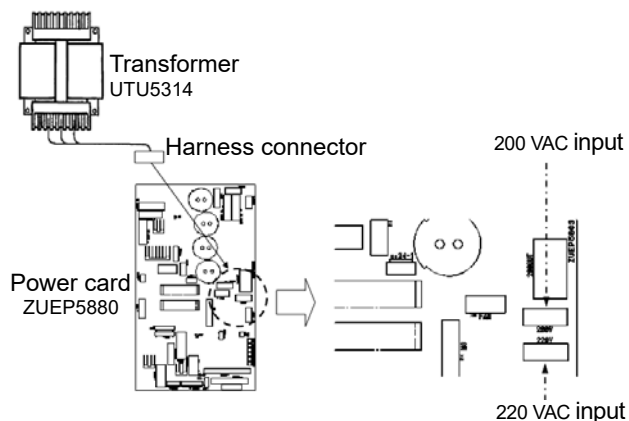

<Built-in welding power source>

Open the panel at the bottom of the left side panel of the controller, and change the harness connections of the built-in welding power source.

- Using at 200 VAC: Connect "VIN" and "200 VAC".
- Using at 220 VAC: Connect "VIN" and "220 VAC".

● Applicable model:

YA-1WC**1T**/Y**

- * Other models are not switchable to 220 VAC because the internal parts do not support 220 VAC.

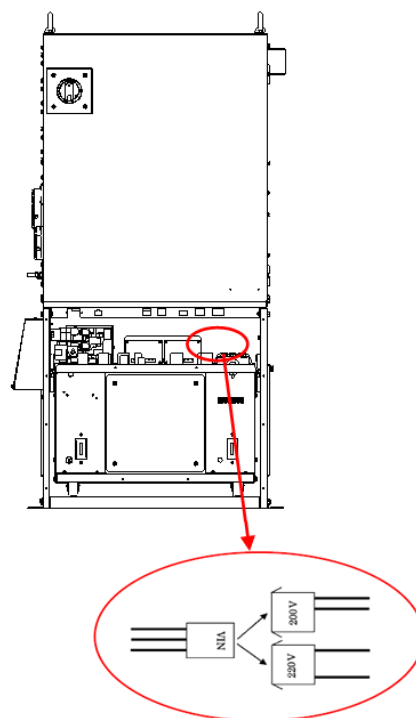

Change harness connection

5.4.5 Door handle

Normally the door handle is in the ON state during operation. The door handle is used to turn ON/OFF the switch.

Note

- Allow 3 second interval after turning off the door handle and before back ON again.
If the interval is not long enough, the alarm "Accidental power failure is detected." can occur. In such a case, turn on the power switch again.
- Please allow 3 to 5 minutes of cooling down of the inside of the built-in welding power source after welding operation before turning power off the door handle.

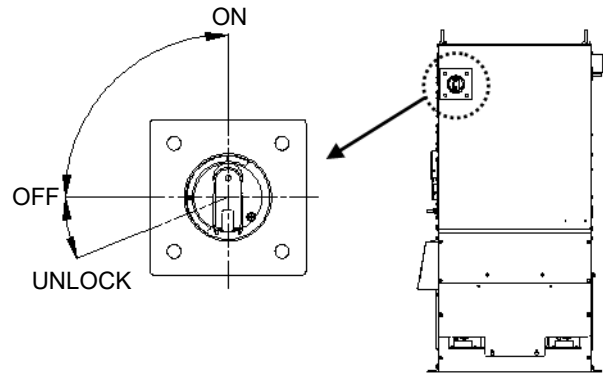

< Operation >

- (1) Turn the handle clockwise to turn ON the switch, and counter-clockwise to turn it OFF. Turn the handle further to the left to UNLOCK the door.
- (2) Set the handle to the OFF position before closing the door.
When the door switch is turned on, power to the robot controller and power to the built-in welding power source are turned on.

5.4.6 Lock switches with padlock

1) Lock the door handle switch

Use a padlock (customer preparation) to lock the door handle at the OFF position.

- Set the door handle to the OFF position.
- Push the end of the handle, then the hasp for a padlock comes out.
- Put a padlock on the door handle.

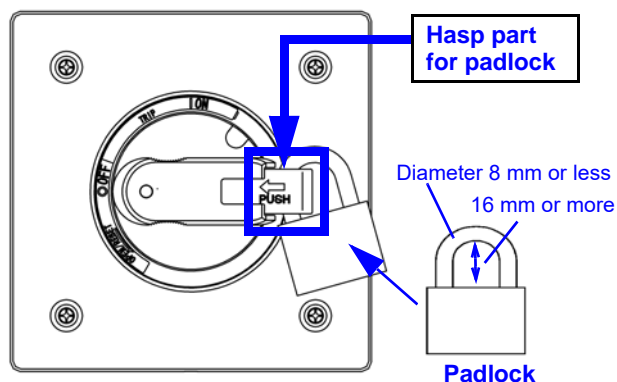

2) Lock the breaker switch inside the controller

Use a padlock (customer preparation) to lock the breaker switch inside the controller at the OFF position. Refer to the following figure to set a padlock.

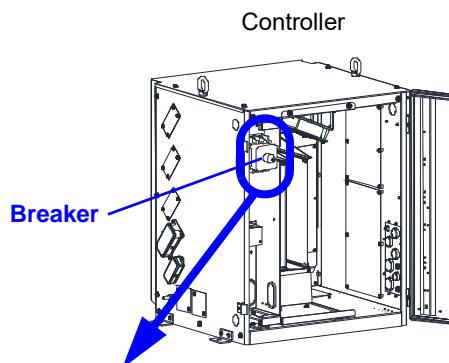

* Shape of the breaker switch varies with the period when the controller was manufactured.

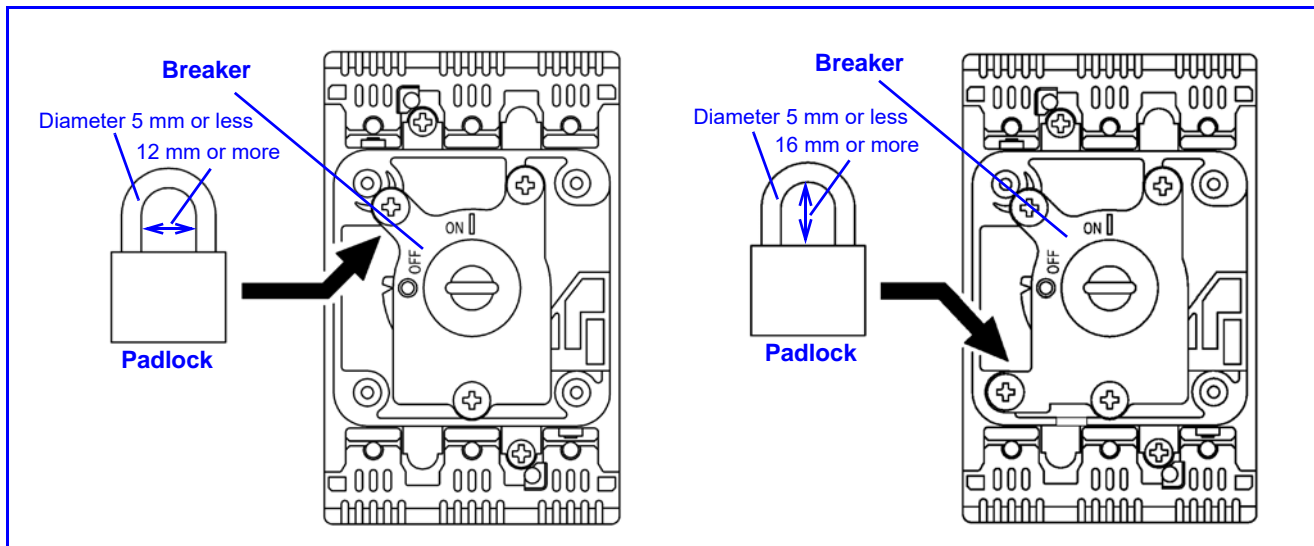

5.5 Connecting to external device

⚠ CAUTION

- Apply a radio shield wire as I/O connecting cable between an external device and robot I/O circuit in order to protect the controller from noise.
- Connect the shield wire to the FE terminal (⚡) on the left side of the controller.
- The FE terminal is provided to prevent noise.
- If a system comprises a machine which generates high frequency (such as TIG, plasma), the robot I/O circuit may be damaged by the high frequency noise. Be sure to design so that any external input to the system should use a no-voltage contact signal and any output to an external device should be converted into relay contact output.
- At the time of wiring to the inside of the controller, make sure to apply measures against noise by running the lead-in cables along the side panel or base panel to keep the lead-in cables away from the boards and cables inside the controller.
- Do not connect the ground cable to the COM of the sequencer card. Otherwise, it will cause the controller to malfunction or break down.

5.5.1 Connecting to external device

- To connect cables from an external device to the robot I/O circuit, draw the cables into the controller through the wiring ports on the IO panel located at the lower right of the right side panel of the controller (see the figure on the right).
- At the time of drawing a cable through the wire port, make sure to fix the cable with a cord lock or the like so as to prevent dust from getting into the controller.
(* Remove the hole plug of the wiring port when drawing a cable.)

As for each of the following connections, please refer to the specified section.

Safety I/O circuit	6. Safety I/O Specifications
External device	7. External Control Signal Connection

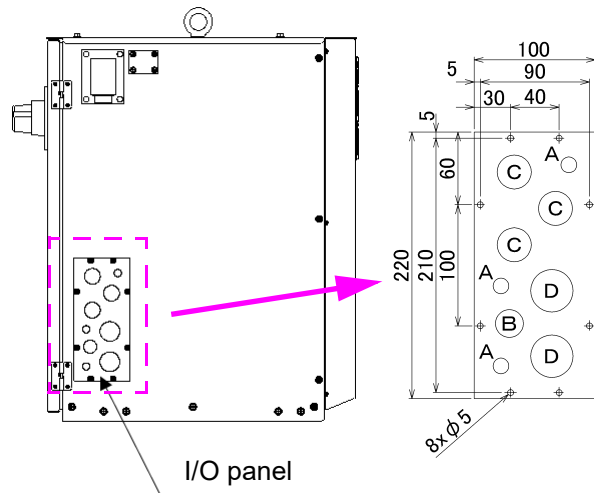

I/O panel hole diameters	
Hole A (3 holes)	13 mm
Hole B (1 hole)	23 mm
Hole C (3 holes)	28 mm
Hole D (2 holes)	35 mm

5.6 Using noise filter unit

● Part list

No	Description	Q'ty	Note
1	Clamp filter	1	Accessories
2	Fixing band	1	
3	Fixing plate	1	

● Installation

- (1) Connecting procedure varies with COM the signal wire is connected to. (See the figure on the right.)
 - (a) Disconnect the signal wire from COM (A), wind it around the clamp filter four turns, and then connect it to COM (A).
 - (b) Disconnect the signal wires from COM (A) and COM (B), wind them around the clamp filter four turns, and then connect them to COM (A).
 - (c) Disconnect the signal wire from COM (B), wind it around the clamp filter, and then connect it to COM (A).
- (2) Bind the clamp filter and the fixing plate and fix them on the bottom plate of the robot controller.

Note

Check the followings of the following phenomena occur.
 The detector activates without a collision.
 The servo turns off on its own during the welding operation in program test mode.
 A file closes on its own during the welding operation in program test mode.

- Check if shielded cables are used.
- Check if the clamp filter is attached to the input/output signal cable.
- Disconnect all input/output signal wires and then check if the above phenomena still occur. If the same error occurs, please consult your local Panasonic distributor.

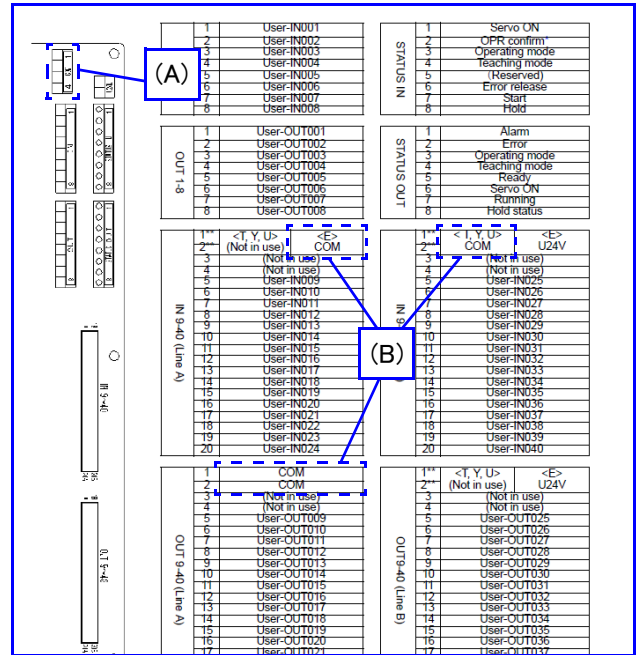
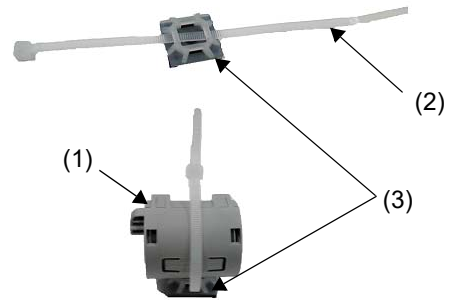

6. Safety I/O Specifications

WARNING

The product is delivered in emergency stop state. (Open Installation input)
 Confirm total safety of robot system and then short-circuit the external emergency stop input after the completion of the installation and start-up of the system.

CAUTION

About safety circuit

- Apply an independent normally-closed contact and do not connect in parallel.
- In order to avoid malfunction due to contact fusion, apply a contact whose capacity is 5 A or more and the minimum applicable load is 50 mA, 24 VDC.

6.1 I/O for safety circuit

Dual circuit is applied to the safety circuit in order to ensure safety.
 Use the safety I/O of the safety card of the controller.
 Please observe the specifications of the safety I/O as follows.

Note

Make sure to wire the emergency stop input cable carefully to minimize the resistance value of the emergency stop input cable path.
 If the resistance of the path becomes 2 Ω or more due to poor connection or other reasons, an emergency stop alarm may go off or an alarm may not be able to reset.

6.1.1 Spare emergency stop input

A spare emergency stop input terminal provided as the most significant level of safety circuit. Apply it when an emergency stop input from an external device is so connected that the output of which takes first priority over all other emergency stop push-button switches on the teach pendant.

Use one normally closed 2-contact switch.

- Connect one set of contacts between “SPEMG1+” and “SPEMG1-”, and the other set between “SPEMG2+” and “SPEMG2-”.
- If this input terminal is not to be used, short terminals between “SPEMG1+” and “SPEMG1-”, and also “SPEMG2+” and “SPEMG2-” without fail. (They are factory shorted at shipment.)

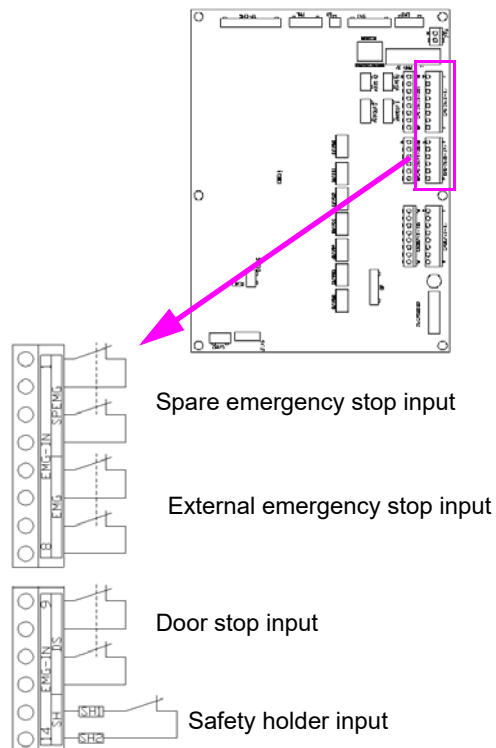

6.1.2 External emergency stop input

- (1) An input terminal to turn off the servo power of the manipulator from an external device.
- (2) Prepare a switch with two normally closed contacts. Connect one set of contacts between "EXTEMG1+" and "EXTEMG1-", and the other set between "EXTEMG2+" and "EXTEMG2-" of the external emergency stop input.

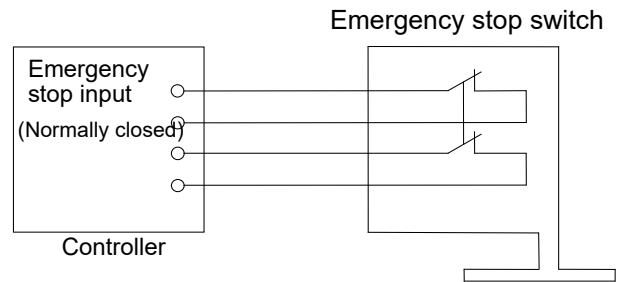

6.1.3 Door stop input

An input terminal to input door status (open/closed) of robot safety fence.

Use a switch with two normally closed contacts.

The robot goes into an emergency stop state when the switch is switched to "OPEN" and the door stop input is input.

Note

- Please note that the door stop input does not function in "TEACH" mode.
- It is factory set to "OPEN" at shipment. With that setting, it is possible to connect interlock of the safety fence and use it.

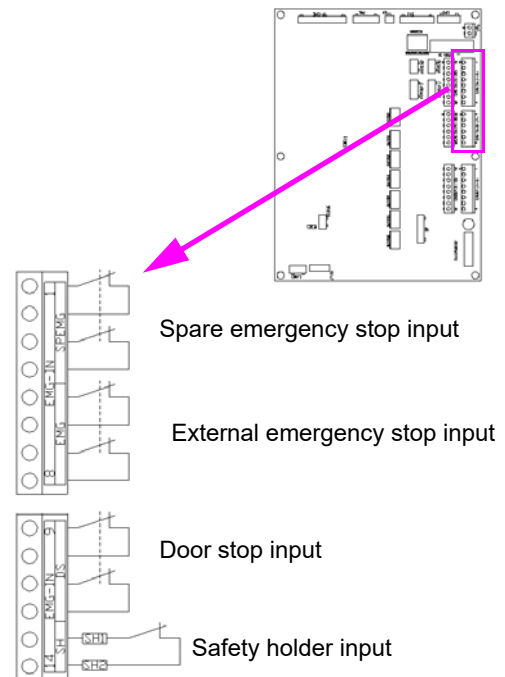

Safety I/O Specifications

6.1.4 Protective stop 1 input

If the terminal is opened, driving force for all robot axes is stopped in terms of hardware, which stops all operation parts at once.

If the terminal is short-circuited, the safety circuit goes into the ready-to-operate state in terms of hardware.

As for other emergency stops, even if the terminal is short-circuited, the safety circuit remains functioning in terms of hardware unless servo is turned on. This is what make this terminal different from other emergency stops.

6.1.5 Protective stop 2 input

Movements are almost the same as that of Protective Stop 1. This terminal is used to receive the emergency stop output from its cooperative counterpart in multi-cooperative robot control.

6.1.6 External Dead Man's input

- An input terminal used to make the Dead Man's function effective from an external input.
- Servo power is turned ON when both the Dead Man's switch on the teach pendant and the external Dead Man's input are ON. Use one normally open 2-contact switch.

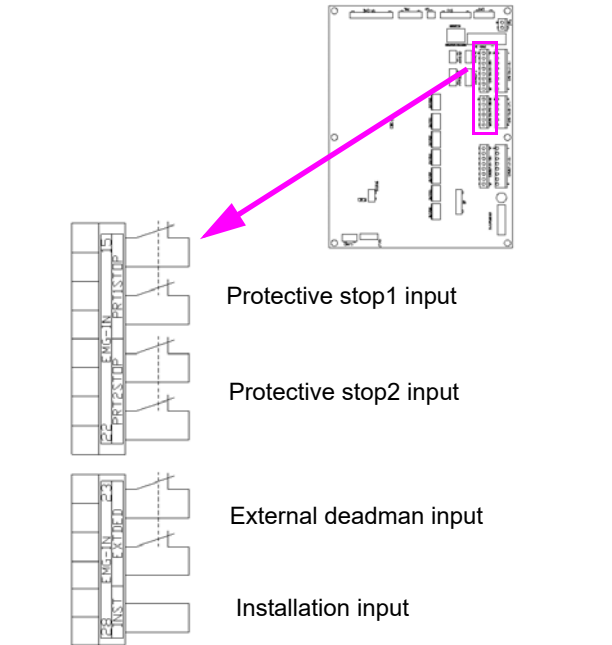

- In case that the external Dead Man's input is not used, set the terminals in the following state:
Short the terminals EXTDED 2+” and “EXTDED 2-”.
(They are factory shorted at shipment.)

6.1.7 Input of the safety circuit

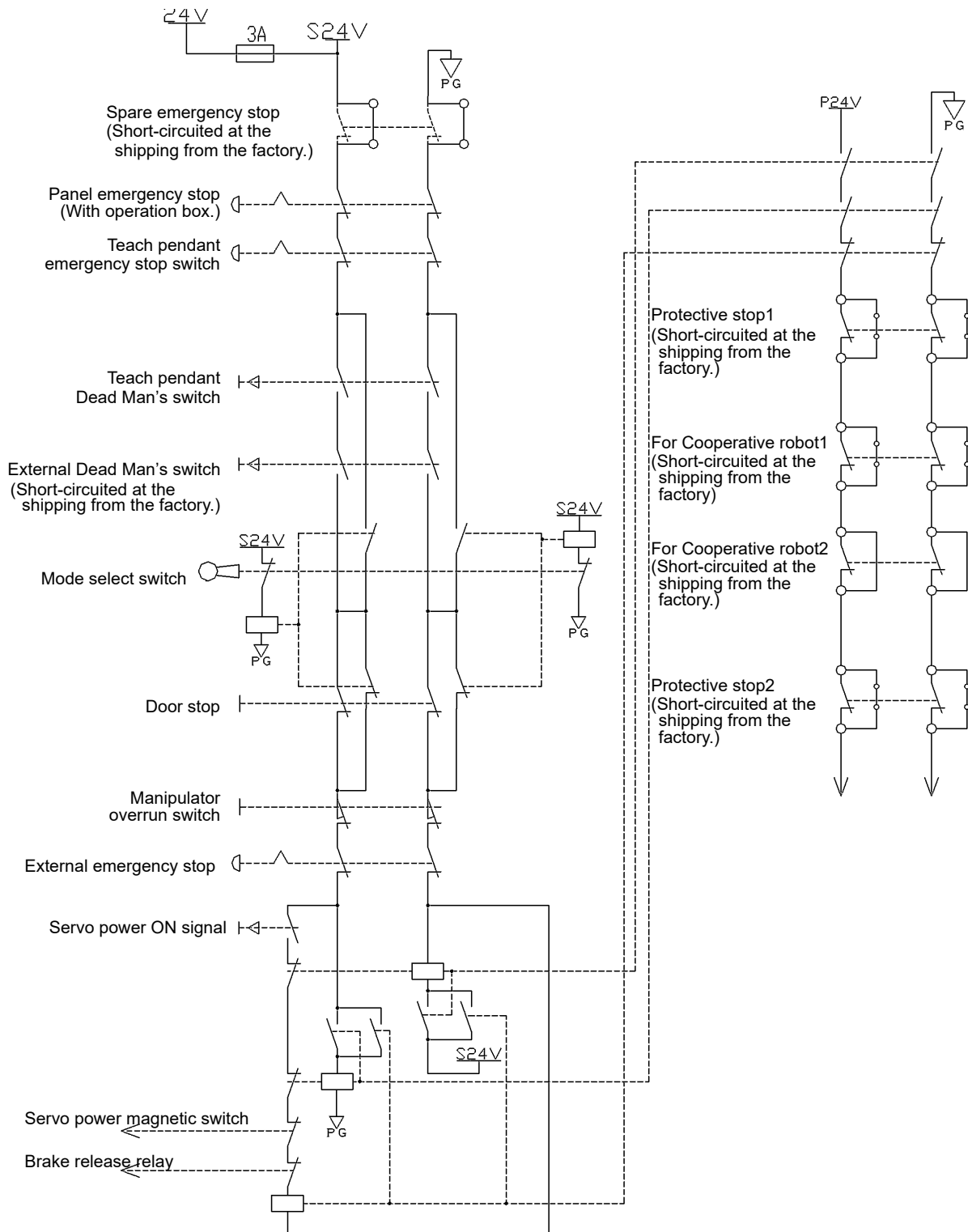

- The controller with built-in welding power source is also equipped with the safety circuit. In case of an emergency stop, the safety circuit turns off the primary power of the welding power source. As it also turns off power to the wire feeder, the wire feeder becomes disabled at an emergency stop state.

Safety I/O Specifications

6.1.8 Emergency stop output

An output terminal to output the emergency stop state.
 (No-voltage relay contact output, Contact ratings: 5 A, 30 VDC, minimum load 100 mA 5 VDC) Open the terminals in an emergency state.

There are four kinds of emergency stop outputs as follows

1	Emergency stop output	How connectors "OUTMD0" to "OUTMD6" of the Safety card are shorted determines its output conditions.
2	Reserved emergency stop output	
3	Emergency stop output for application	How connectors "OUTMD0" to "OUTMD6" of the Safety card are shorted does NOT change its output conditions.
4	Reserved emergency stop output for application	

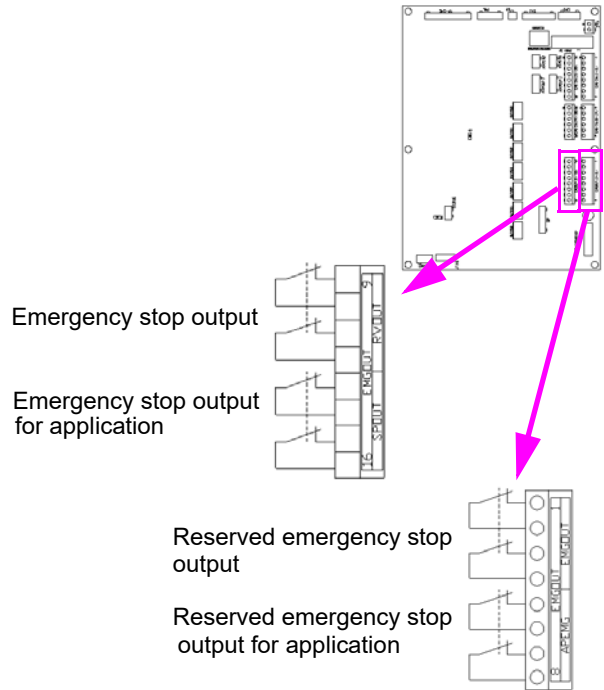

◆ Short connectors and emergency stop

The following show the relationships between emergency stop input type and emergency stop output when each connector is shorted.

Note

OUTMD3 is factory short-circuited.

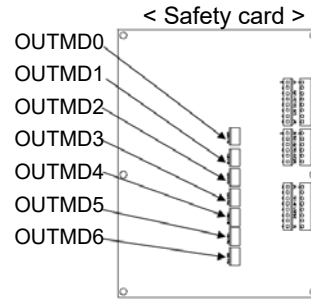

Emergency stop output		"Emergency stop output" and "Reserved emergency stop output"							"Emergency stop output for application" and "Reserved emergency stop output for application"
		OUTMD0	OUTMD1	OUTMD2	OUTMD3	OUTMD4	OUTMD5	OUTMD6	
Shorted connector		OUTMD0	OUTMD1	OUTMD2	OUTMD3	OUTMD4	OUTMD5	OUTMD6	Not related
(1)	Spare emergency stop input	C	C	C	A	A	A	A	A
(2)	Panel emergency stop input (*1)	C	C	C	A	A	A	B	A
(3)	Teach pendant emergency stop input	C	C	C	A	A	A	B	A
(4)	Teach pendant Dead Man's switch (*2)	C	C	C	A	A	B	B	A
(5)	External Dead Man's input (*2)	C	C	C	A	A	B	B	A
(6)	Door stop input (*3)	C	C	C	A	A	B	B	A
(7)	Overrun input	C	C	C	A	A	B	B	A
(8)	External emergency stop input	C	C	C	A	B	B	B	A
(9)	Protective stop 1 input	E	E	E	B	B	B	B	B
(10)	Emergency stop of its cooperative counterparts in multi-cooperative robot control.	E	E	B	B	B	B	B	B
(11)	Protective stop 2 input	E	B	B	B	B	B	B	B
(12)	In alarm condition	D	D	D	D	D	D	D	D

(*1) It is available only if an operation box (optional) is connected.

(*2) As for Dead Man's switch, the input is valid only when the TEACH mode select switch is in TEACH position.

(*3) As for Door stop switch, the input is valid only when the AUTO mode select switch is in AUTO position.

A	The emergency stop output terminal goes open when the emergency stop input is input. The emergency stop output terminal is closed when the emergency stop input is released. (In case the mode select switch is in TEACH mode, the emergency stop output terminal stays open state when the Dead Man's switch input is turned on.)
B	The emergency stop output terminal stays closed regardless of the state of the emergency stop input.
C	The emergency stop output terminal goes open when the emergency stop input is input. The emergency stop output terminal is closed when the emergency stop input is released and the servo power is turned on.
D	Input to open the emergency stop output terminal. It remains in open state until the power at the controller is turned off.
E	When the main power is turned on, the emergency stop output terminal goes into the output status of "C". Then, when the servo power is turned on, the output terminal goes into the output status of "A". If one of the following (1) to (8) inputs is turned on, the output terminal goes back into the output status of "C". Subsequently, if the servo power is turned on, the output terminal goes into the output status of "A".

6.2 Other safety input/output

Ensure a safe work environment by using the safety I/O equipped with the safety card.

6.2.1 Safety holder input

Input terminals for safety holder cable, which is not included in the safety circuit. The input is always monitored by software. The safety holder cables are factory connected to the safety holder input terminals as shown in the figure.

Note

- If the safety holder input terminal is not used, remove the safety holder cable and insulate it and then short-circuit the input terminal.
- “SH1” and “SH2” do not have polarity.

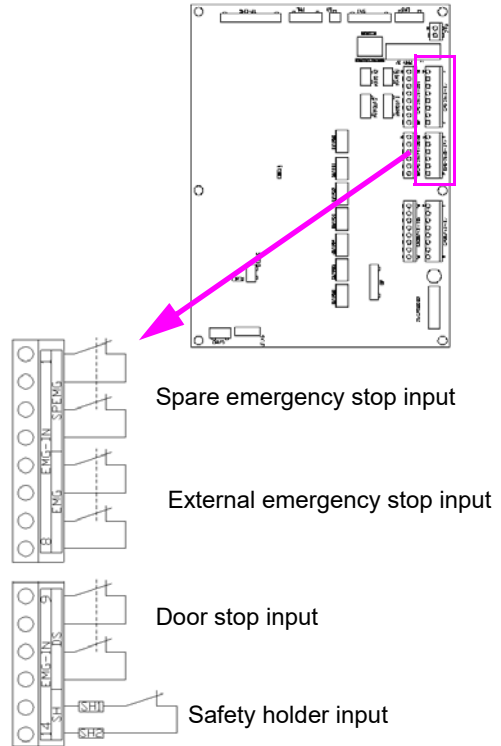

6.2.2 Installation input

Set the input open to indicate the warning message “Now installing. Check wire connections. Short INST.” on the screen of the teach pendant every time the controller is turned ON and mode change (operation mode/teaching mode) is executed so as to warn the operator of the robot system that the safety I/O setting of the robot system has not completed.

Note

Short this input after the completion of the installation and start-up of the system or in normal operation.

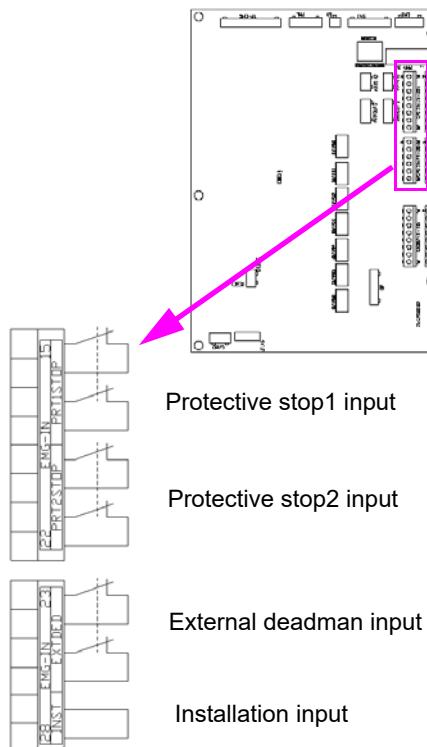

7. External Control Signal Connection

7.1 Terminal location of the sequencer card

Specifications	Part number	Output type
T /Y/R	ZUEP5789	Open collector
E	ZUEP5826	Open emitter

Note

- Allocation of User I/O terminals vary with start method.
- Terminals marked with
 - *: An additional setting is needed to enable the signal.
 - ** : Functions vary with the circuit board (see left table).

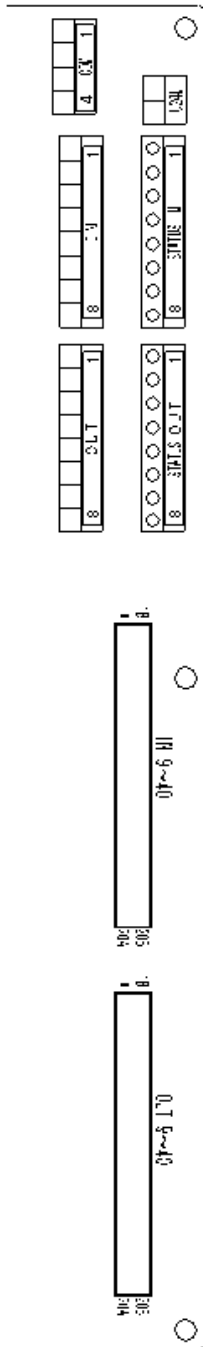

IN 1-8	Terminal	Signal
	1	User-IN001
	2	User-IN002
	3	User-IN003
	4	User-IN004
	5	User-IN005
	6	User-IN006
	7	User-IN007
	8	User-IN008

STATUS IN	Terminal	Signal
	1	Servo ON
	2	OPR confirm*
	3	Operating mode
	4	Teaching mode
	5	(Reserved)
	6	Error release
	7	Start
	8	Hold

OUT 1-8	Terminal	Signal
	1	User-OUT001
	2	User-OUT002
	3	User-OUT003
	4	User-OUT004
	5	User-OUT005
	6	User-OUT006
	7	User-OUT007
	8	User-OUT008

STATUS OUT	Terminal	Signal
	1	Alarm
	2	Error
	3	Operating mode
	4	Teaching mode
	5	Ready
	6	Servo ON
	7	Running
	8	Hold status

IN 9-40 (Line A)	1**	<T, Y, R>	<E>
	2**	(Not in use)	COM
	3	(Not in use)	
	4	(Not in use)	
	5	User-IN009	
	6	User-IN010	
	7	User-IN011	
	8	User-IN012	
	9	User-IN013	
	10	User-IN014	
	11	User-IN015	
	12	User-IN016	
	13	User-IN017	
	14	User-IN018	
	15	User-IN019	
	16	User-IN020	
	17	User-IN021	
	18	User-IN022	
	19	User-IN023	
	20	User-IN024	

IN 9-40 (Line B)	1**	<T, Y, R>	<E>
	2**	COM	U24V
	3	(Not in use)	
	4	(Not in use)	
	5	User-IN025	
	6	User-IN026	
	7	User-IN027	
	8	User-IN028	
	9	User-IN029	
	10	User-IN030	
	11	User-IN031	
	12	User-IN032	
	13	User-IN033	
	14	User-IN034	
	15	User-IN035	
	16	User-IN036	
	17	User-IN037	
	18	User-IN038	
	19	User-IN039	
	20	User-IN040	

OUT 9-40 (Line A)	1	COM
	2	COM
	3	(Not in use)
	4	(Not in use)
	5	User-OUT009
	6	User-OUT010
	7	User-OUT011
	8	User-OUT012
	9	User-OUT013
	10	User-OUT014
	11	User-OUT015
	12	User-OUT016
	13	User-OUT017
	14	User-OUT018
	15	User-OUT019
	16	User-OUT020
	17	User-OUT021
	18	User-OUT022
	19	User-OUT023
	20	User-OUT024

OUT9-40 (Line B)	1**	<T, Y, R>	<E>
	2**	(Not in use)	U24V
	3	(Not in use)	
	4	(Not in use)	
	5	User-OUT025	
	6	User-OUT026	
	7	User-OUT027	
	8	User-OUT028	
	9	User-OUT029	
	10	User-OUT030	
	11	User-OUT031	
	12	User-OUT032	
	13	User-OUT033	
	14	User-OUT034	
	15	User-OUT035	
	16	User-OUT036	
	17	User-OUT037	
	18	User-OUT038	
	19	User-OUT039	
	20	User-OUT040	

External Control Signal Connection

● Sequencer card

Terminal or connector	Application	
COM	Common	
U24V	(T/Y/R spec.)	Maintenance
	(E spec.)	24 VDC input for I/O

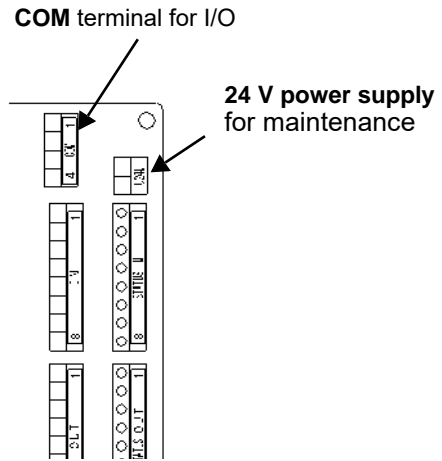

7.2 Serial interface

The backplane card is provided with serial connectors to connect optional units and/or welding power source.

Connector	Application
RS-232C RS-422	For an optional units or digital communication of welding power source.
EX_IO	For an optional unit.

Refer to the following correspondence table of port numbers and connectors.

Connector	Port number	Connector symbol
RS-232C	Port 1	232C-1(X20)
	Port 2	232C-2(X17)
	Port 3	232C-3(X16)
RS-422	Port 1	422-1(X19)
	Port 2	422-2(X18)
	Port 3	422-3(X12)
	Port 4	422-4(X11)
	Port 5	422-5(X9)

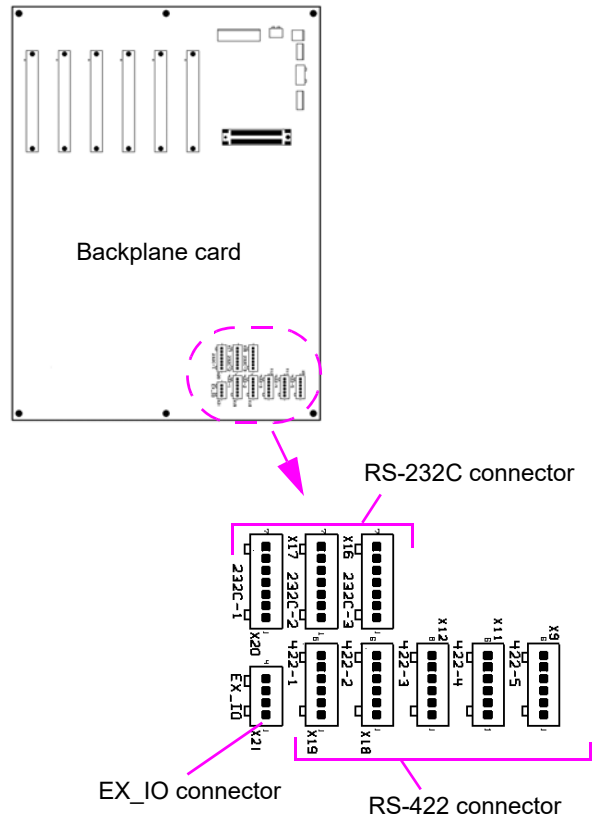

7.3 I/O terminal equivalent circuit

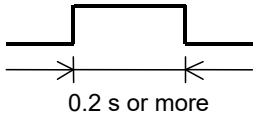
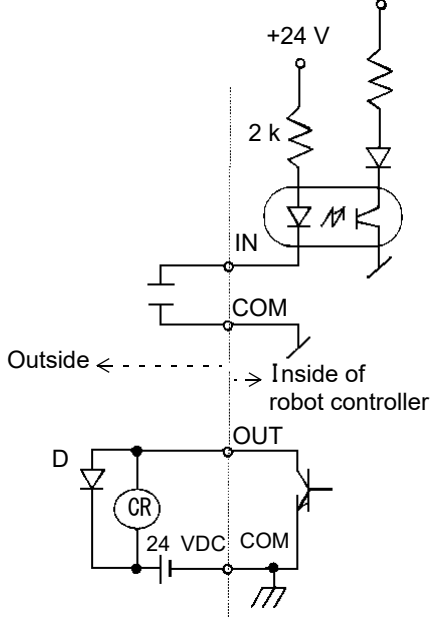
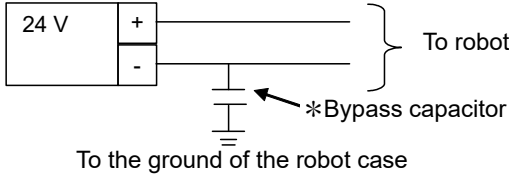
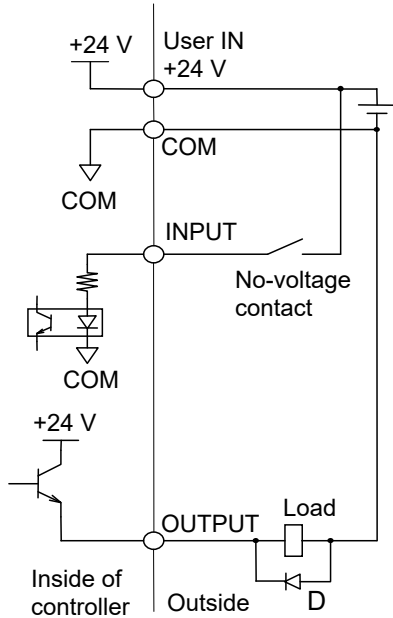
Spec.		
T/Y/R	<p>● Input terminal equivalent circuit</p> <ul style="list-style-type: none"> To receive no-voltage ON/OFF contact signal from an external equipment. External relay contact to be connected 1 ohm or less, Chattering 10 ms or less Pulse width of an input signal should be 0.2 s or more.  <p>0.2 s or more</p> <p>● Output terminal equivalent circuit</p> <ul style="list-style-type: none"> Open collector output. Rated output is 24 VDC, 75 mA. Use a relay whose coil voltage is 24 VDC and coil current is 75 mA DC or less, and attach a noise adsorbing diode: D (100 V, 1 A). Capacity of the emergency stop output contact: 5 A, 30 VDC. 	 <p>Outside ← → Inside of robot controller</p>
E	<p>● Power to activate input/output</p> <ul style="list-style-type: none"> It is necessary to apply 24 VDC of supply voltage between 24 V input and COM. Turn ON/OFF the power synchronous to the control power of the robot controller. The power to be provided by customer: <ul style="list-style-type: none"> Voltage: 24 VDC +10 %/-0 % Capacity: 75 W or more Make sure that noiseless power is applied. <p>It is recommended to use a bypass capacitor to remove especially the common-mode noise (see below figure). Recommended bypass capacitor: Film capacitor 0.1 μF, 50 V.</p>  <p>To the ground of the robot case</p> <p>*Bypass capacitor</p> <p>● Input terminal equivalent circuit:</p> <ul style="list-style-type: none"> To receive no-voltage ON/OFF contact signal from an external equipment. External relay contact to be connected 1 ohm or less Chattering 10 ms or less Pulse width of an input signal should be 0.2 s or more. <p>● Output terminal equivalent circuit</p> <ul style="list-style-type: none"> Open emitter output. Rated output is 24 VDC, 75 mA Use a relay whose coil voltage is 24 VDC and coil current is 75 mA DC or less, and attach a noise adsorbing diode: D (100 V, 1 A). Capacity of the emergency stop output contact: 5 A, 30 VDC. 	 <p>Inside of controller Outside</p>

External Control Signal Connection

7.4 Auto start settings

For details of settings and usage of the auto start, please refer to the operating instructions (Teach pendant for arc welding industrial robots.)

7.5 Status IN/OUT

Dedicated input/output terminals to send signals when the robot is in specified state or to change robot status according to the signal received.

7.5.1 Status INPUT

- Dedicated input terminals

Status INPUT	Description
External servo ON input	<p>Turn ON to enable servo power ON if the following conditions are all satisfied.</p> <p><u>Condition 1:</u> Status output signal 'Ready' output signal is ON.</p> <p><u>Condition 2:</u> Mode select switch is set to operation mode ('AUTO' position) and not in Mode error state.</p> <p><u>Condition 3:</u> Mode select is set to auto-operation (in operation mode)</p> <p><u>Condition 4:</u> Mode select switch is not switched to 'TEACH' position due to override in operation.</p> <p><u>Condition 5:</u> The 'Emergency stop' input is not ON.</p> <p>The input signal must satisfy the following conditions.</p> <p>The input signal must be ON in 0.2 second after the 'Ready' output signal goes ON.</p> <p>The input signal must be kept ON for 0.2 second or more.</p> <p>If you try to turn on servo within 1.5 seconds after turning it off, "Retry to turn on servo" is displayed and servo doesn't turn on .</p>
Error release input	<p>When the robot is in an error state and the error dialog box is displayed, turn ON this input to close the dialog box. At that time, the error output goes off if it is in ON state. Input signal is effective when the signal state is switched and kept for 0.2 second or more.</p>
Start input	<p>Turn ON this input signal to run a program. In a hold state, turn on to restart. The input signal is ignored under the following conditions.</p> <ul style="list-style-type: none"> • The servo power is OFF. • Auto-operation is not set. • In error condition. • Stop input is ON. • In override state.
Stop input	<ul style="list-style-type: none"> • Turn ON this input signal to bring the operating robot into a hold state. • While the signal is ON, re-start, manual operation and trace operation are not operable. • The robot remains in a hold state even if this signal is turned OFF. • To restart operation, turn ON the start input signal.
Operating mode input	<ul style="list-style-type: none"> • It is to switch the mode from teaching mode to operation mode. • Use this input when the robot is in teaching mode and operation mode is desired. • When the input signal is turned ON, a message to switch the mode select switch to operation mode appears. • Switch the mode select switch to 'AUTO' or turn OFF the operating mode input to close the message box. <p>Please be advised that while the message box is displayed, the robot is in the error state.</p>
Teaching mode input	<ul style="list-style-type: none"> • It is to switch the mode from operation mode to teaching mode. • Use this input when the robot is in operation mode and teaching mode is desired. • When the input signal is turned ON, a message to switch the mode select switch to teaching mode appears. • Switch the mode select switch to 'TEACH' or turn OFF the teaching mode input to close the message box. <p>Please be advised that while the message box is displayed, the robot is in the error state.</p>
OPR confirm input	<p>In case of using the operation box, turn ON this input signal to release the interlock occurred at the time of switching to AUTO mode. (You can also use the AUTO mode switch on the operation box to release the interlock.)</p> <p>< Note ></p> <ul style="list-style-type: none"> • The interlock at the time of switching to AUTO mode occurs if the controller is equipped with the operation box either as standard (for RIA or CE specification) or as optional. • It is necessary to complete the management settings for the operation box to enable this input. Please refer to the operating instructions (Operation) for details.

7.5.2 Status OUTPUT

- Dedicated output terminals

Status OUTPUT	Description
Alarm output	<ul style="list-style-type: none"> • The signal is output when the robot goes into an alarm condition. (At that time servo power is turned OFF) • Unless power is turned OFF, the output signal remains in ON state.
Error output	<ul style="list-style-type: none"> • The signal is output while the robot is in an error condition. • The signal is turned OFF when the error is released.
Operating mode output	<ul style="list-style-type: none"> • The signal is output in operation mode (including override.) • While the message box to switch to teaching mode is displayed (by turning on the 'Teaching mode' input), if the operation mode is selected, this signal remains ON.
Teaching mode output	<ul style="list-style-type: none"> • The signal is output in teaching mode (excluding override.) • While the message box to switch to operation mode is displayed (by turning on the 'Operating mode' input), if the teaching mode is selected, this signal remains ON.
Ready output	<ul style="list-style-type: none"> • The signal is output when the robot is ready to receive a status input signal. • It goes OFF when the robot is in an alarm condition or when the 'Emergency stop' input is ON.
Servo ON output	<ul style="list-style-type: none"> • The signal is output when the servo power is ON. <p><Examples of installing a signal light></p> <div style="display: flex; justify-content: space-around;"> <div style="border: 1px solid black; padding: 5px; width: 45%;"> <p>T / Y / R spec. Connection to the Open collector circuit</p> </div> <div style="border: 1px solid black; padding: 5px; width: 45%;"> <p>E spec. Connection to the Open emitter circuit</p> </div> </div>
Running output	<ul style="list-style-type: none"> • The signal is output while running a program (including override.) • It is turned OFF when the robot goes in hold or emergency stop state, and turned ON again when the robot is re-started.
Hold status output	<ul style="list-style-type: none"> • The signal is output when the running program is stopped in operation mode. • The signal is output while the robot is in a hold state due to an error or emergency stop input, and is turned OFF when re-started. • The signal is turned OFF when the mode select switch is placed in 'TEACH' position. When the mode select switch is placed in operation mode and the robot is ready to restart after turning on servo power, the signal is turned ON. • The output turns off when an emergency stop or an error occurs. The output turns on again when the robot goes back to ready state after recovering from the emergency stop and then turning on the servo power.

7.5.3 Status I/O to be allocated to user terminals

For details of setting procedure and functions of status I/Os allocated to the user terminals, please refer to the operating instructions (Teach pendant for arc welding industrial robots.)

External Control Signal Connection

7.6 Flowchart of Status Outputs

7.6.1 Operating and Holding output

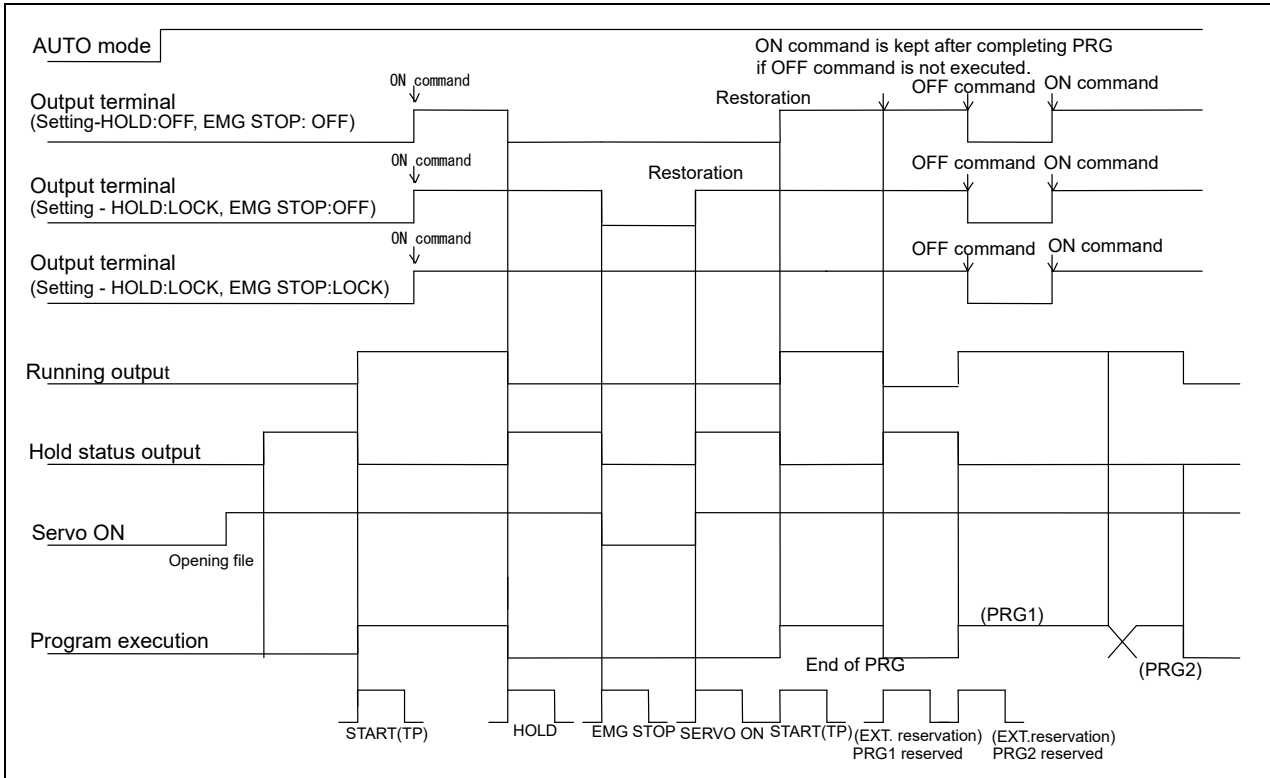

Note

The chart is drawn as positive logical setting case.

7.6.2 Mode change (I/O monitor)

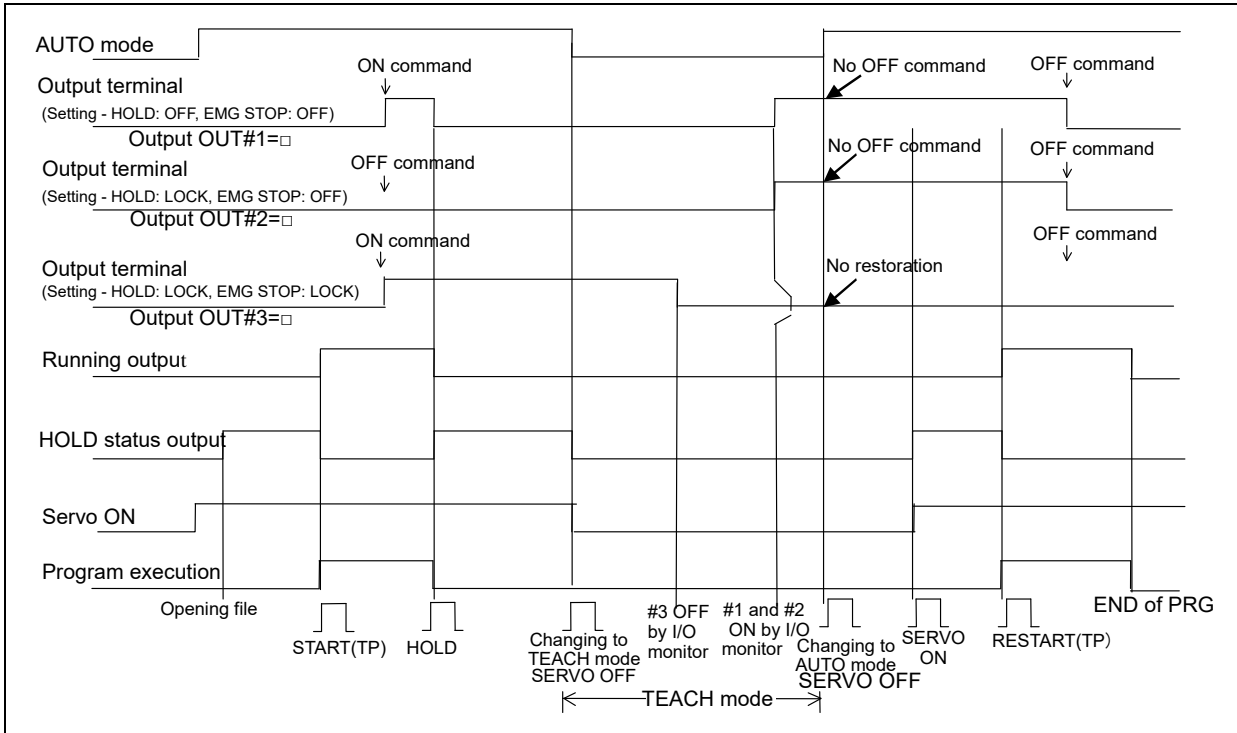

Note

The chart is drawn as positive logical setting case.

7.6.3 Emergency stop 1

The following chart shows output terminal status to the emergency stop operation when it is set to the safety PCB connector OUTMD1.

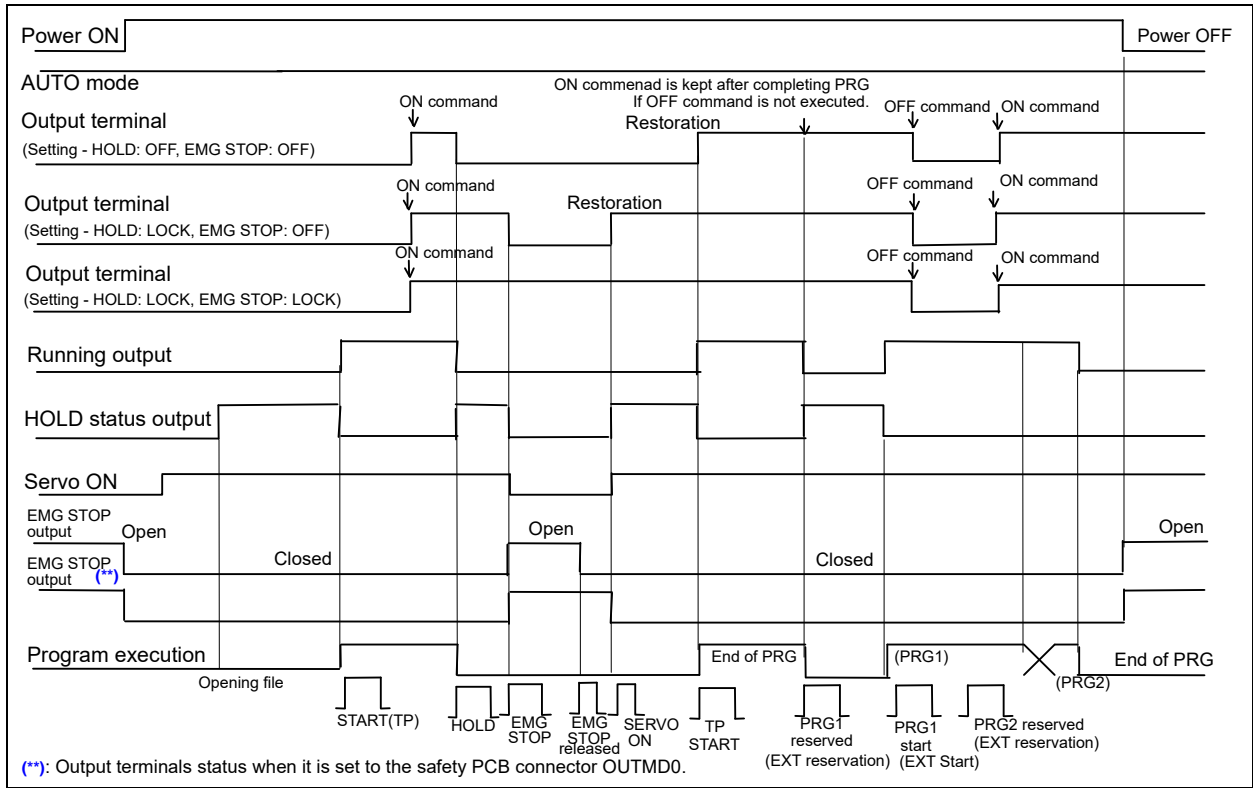

Note

The chart is drawn as positive logical setting case.

7.6.4 Emergency stop 2

Status outputs of “Emergency stop output” and “Emergency stop status output” vary with mode setting.

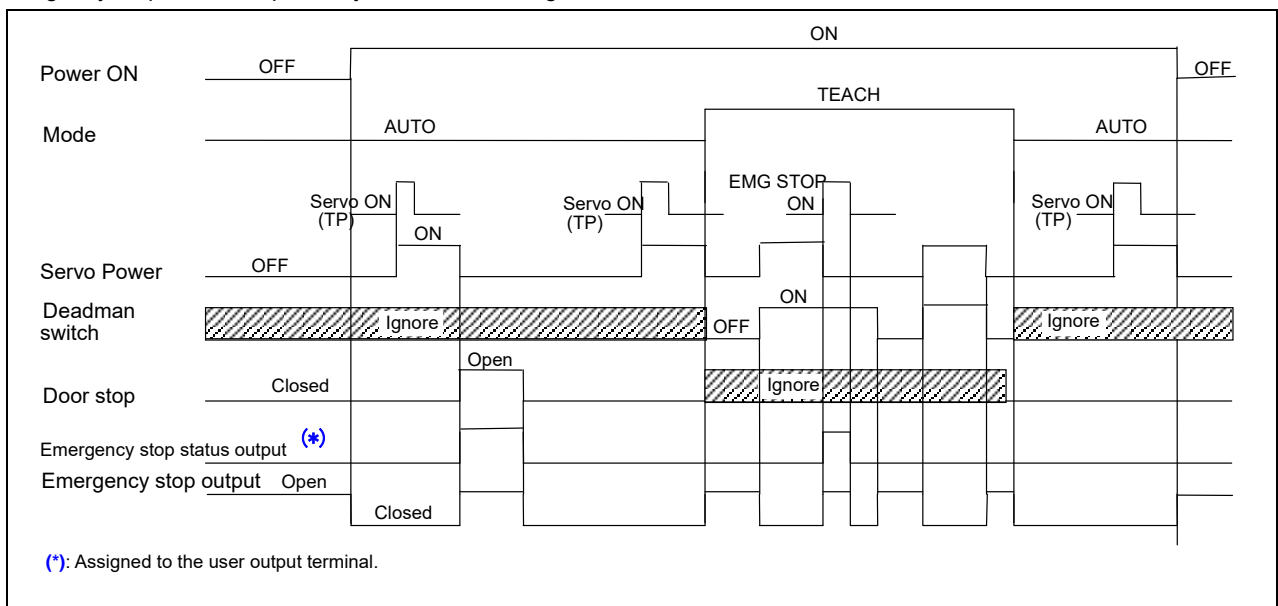

Note

The chart is drawn as positive logical setting case.

External Control Signal Connection

7.6.5 Error output

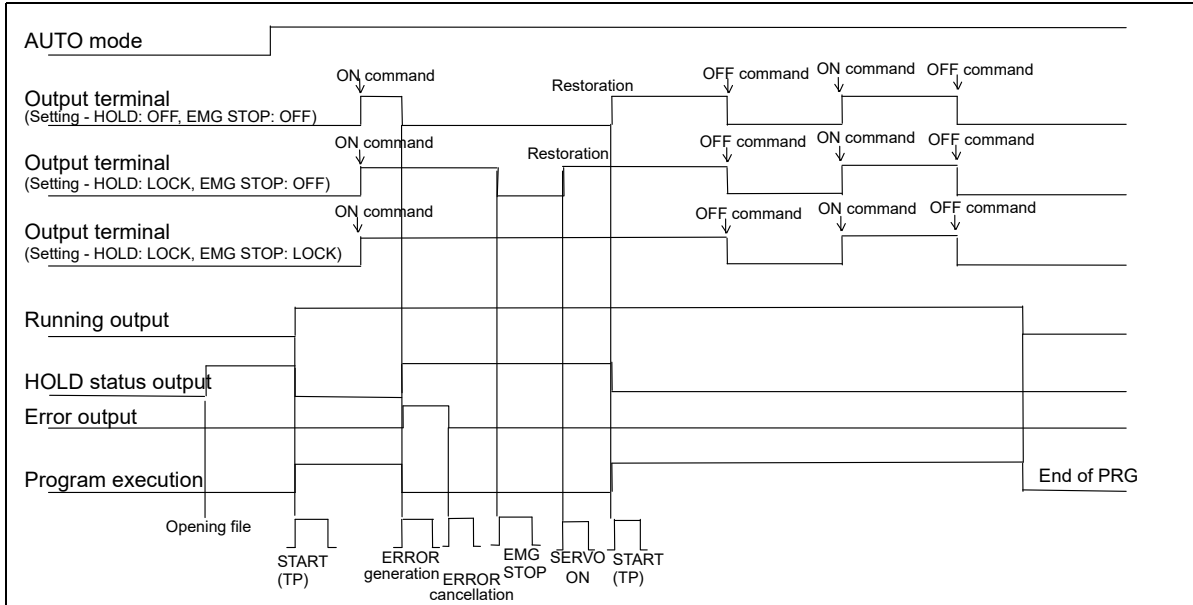

Note

The chart is drawn as positive logical setting case.

7.7 Connecting to the sequencer card

● Terminal part

- Since connector terminals are employed, they can be removed from the board.
- Peel off lead wire cover from about 7 mm from the end and wire it to the terminal with precision flathead (-) driver. (Clamping torque: 0.5 N•m -0.6 N•m)
- Applicable wire: 0.2 mm²-2.5 mm² (AWG24 - AWG12)

● Connector part

Soldering type connector is provided.

Applicable connectors

Connection method	INPUT, OUTPUT	Note
Soldering (Provided)	FCN361J040AU (connector) FCN360C040B (cover)	AWG23 or below
Clamping *	FCN363J040 (housing) FCN363J-AU (contact) FCN360C040B (cover)	AWG24 to AWG28 Coated, φ 1.2 mm or less
Pressure welding *	FCN367J040-AU/F	Flat cable Pitch: 1.27 mm, AWG28 (Stranded wire)

Sequencer card

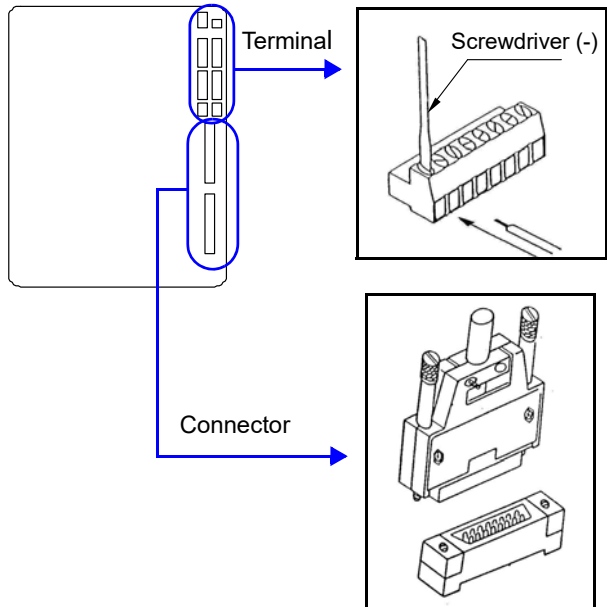

Note

If clamping or pressure welding type is applied, special tools need to be prepared.

7.8 External interface, External memory

7.8.1 SD Memory Card slot (Teach Pendant)

The teach pendant is equipped with a SD memory card slot. Open the cover at the bottom of the teach pendant to access the SD memory card slot. Open the cover and attach the memory card to it to use.

SD memory card	
Recommended product: (Product of Panasonic)	
Part No.:	RP-SDL series
It supports SD memory (maximum capacity 2 GB) and SDHC memory (maximum capacity 32 GB). (SD cards of SDXC standard are not supported.)	

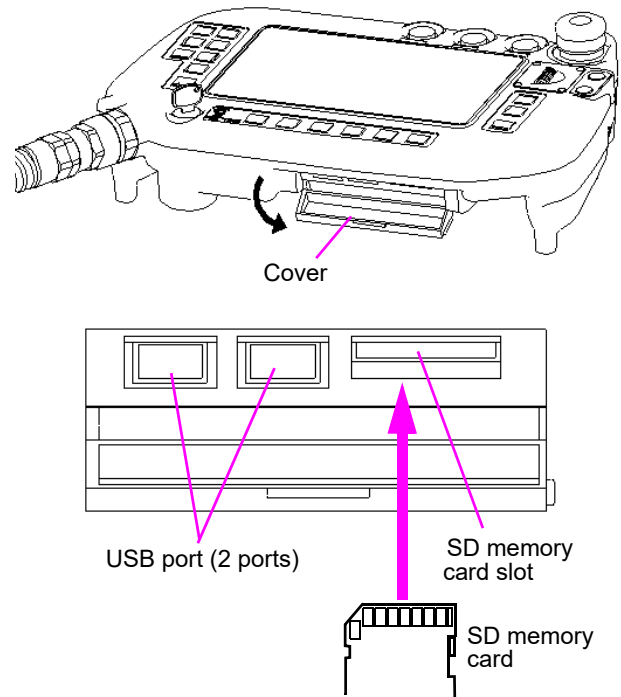

7.8.2 USB port

The teach pendant is provided with two USB ports on the left side of the SD memory card slot. You can connect a USB-compatible keyboard or memory when you use Windows CE.

- Operation confirmed USB memory

Manufacturer	Product number	Capacity
BUFFALO	RUF3-K8GA	8 GB
GREEN HOUSE	GH-UFD4GN	4 GB

<Usage note for USB port>

- The port supports USB 2.0 but does not support Hi-Speed USB.
- Applicable devices for the port are keyboard and memory.
- Depending on the type of keyboard, some functions, such as multimedia, are not available.

7.8.3 SD Memory Card slot (Main CPU card)

(1) Recovery SD memory card slot

It is a slot for TP version auto matching function and Scheduled backup function.

“TP version auto matching function” is available with the software version 9.00 or higher.

(2) User SD memory card slot

It is a slot for optional software. No card is set in the slot at shipment.

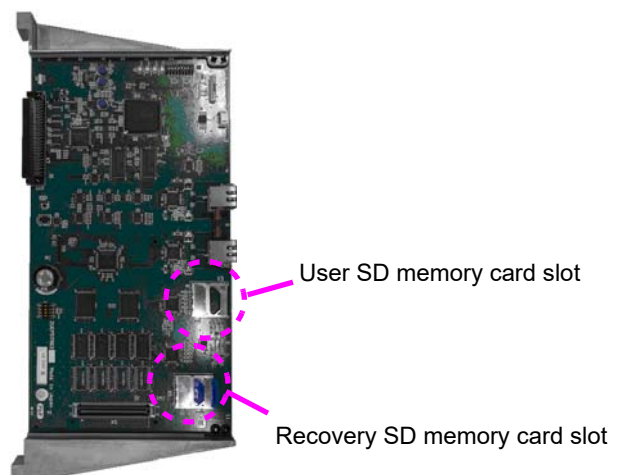

External Control Signal Connection

7.9 Welding voltage/current monitor

In case of using welding voltage/current monitor function, use the provided welding voltage/current monitor terminals.

- Connecting to the monitor terminals
 - (1) Remove the terminal cover at the lower part of the controller front panel.
 - (2) The monitor terminal is located on the right side of the output terminal.
 - (3) In the same manner as output cable, lead the cable to connect the external device and the monitor terminal from the underside of the power.
 - (4) Re-install the output terminal cover back in place to complete.

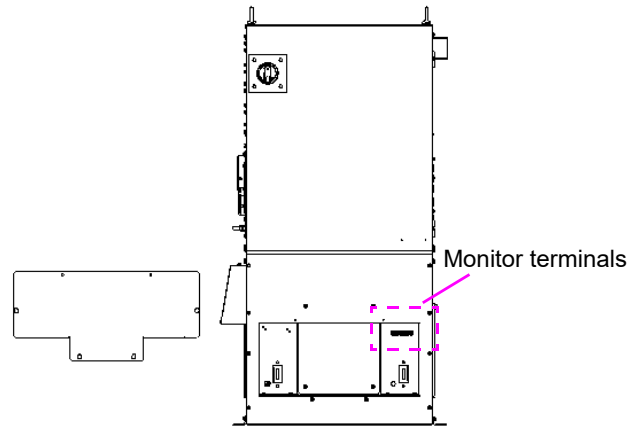

- Layout and functions of the monitor terminals

Terminal name	Function
+ (A) - Welding current monitor terminal	Connect a DC ammeter to between these terminals to monitor welding amperage. (Output terminal from the shunt resistor 600 A/ 60 mV.)
+ (V) - Welding voltage monitor terminal	Connect a DC voltmeter to between these terminals to monitor welding voltage.

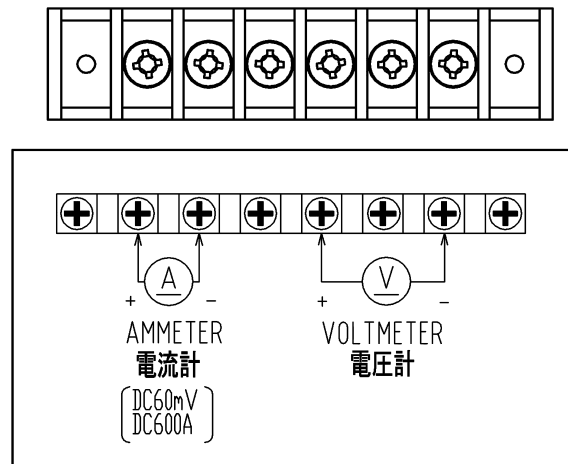

Note

Make sure to connect a DC ammeter and DC voltmeter individually.

8. Motor Brake Manual Release Switch

CAUTION

Be careful of the arm downward motion when you release a motor brake. The robot arm will descend under its own weight if a motor brake is released, which can cause personal injury or damage to a device. Prior to releasing a brake, take measures not to descend the arm or check to confirm that no personnel or no device that may be damaged exists.

8.1 How to release motor brake

Manual motor brake release switches for all axes respectively are located inside of the controller.

- (1) Press the emergency stop switch.

< Note >

Make sure to hold the emergency stop switch in the ON (or pressed) position.

- (2) Turn on the breaker of the controller.
- (3) Release the fastener of the front door.
- (4) Turn the door handle release screw with either phillips-head or flathead screwdriver. Then the door handle can be unlocked while holding power to the controller in the ON position.

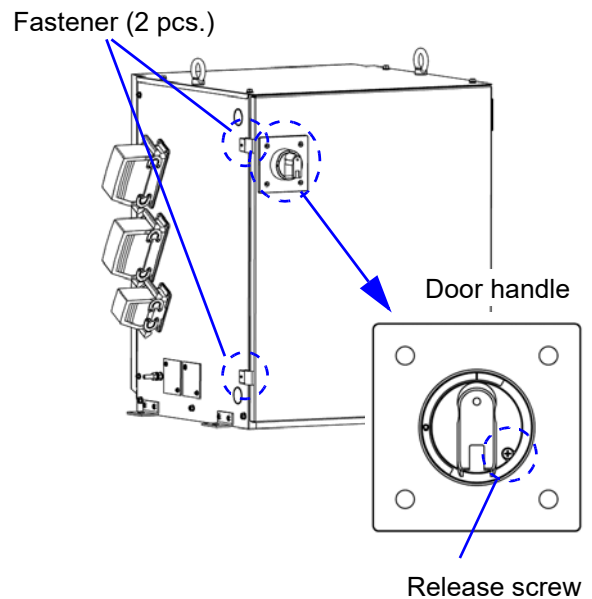

- (5) Access the brake release card installed inside of the controller. Of the axis select switches, turn on an axis switch you want to release the motor brake. While holding the axis switch in the ON position, turn on the RELEASE switch to release the selected axis motor brake of the manipulator.

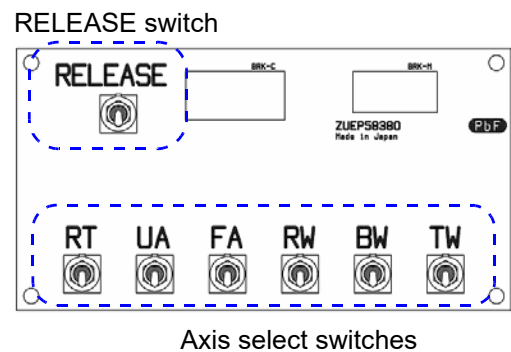

Note

All switches are momentary switches. Once the switch is released, the switch automatically goes back to the OFF position.

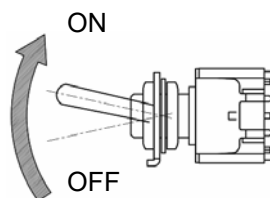

9. Maintenance and Inspection

 WARNING	
	<p>Risk of Electric Shock</p> <ul style="list-style-type: none"> • Disconnect and lockout main power before servicing equipment. • More than one disconnect switch may be required to de-energize the equipment before servicing.

 CAUTION	
<p>Maintenance and inspection work must be performed by qualified personnel who have completed the appropriate training programs.</p> <p>After turning off the power switch, please allow enough time of cooling down of the discharge part and heat-generating part of the capacitor inside the controller before performing maintenance and inspection work.</p>	

9.1 Inspection schedule

Maintenance and inspection works are inevitable to ensure full functions and performance of the robot and at the same time to ensure safety during operation.

- (1) Refer to the table in the next page for the check items.
- (2) Since the inspection intervals are set according to standard operation hours, apply either months or hours whichever is shorter as the standard. In case of operation on two shifts, the every 500-hour inspection shall normally be performed every 1.5 months. Hours correspond to time while the controller is in the ON state.
- (3) It is recommended to have the overall inspection including overhauls specified by us at the time of every 2 000-hour inspection. If you enter into a periodical inspection contract with our company, our periodical inspections will start with a 2 000-hour (annual) inspection.

Inspection schedule
● Daily inspection
● Every 500 hours (or every three months)
● Every 2 000 hours (or every year)
● Every 4 000 hours (or every two years)
● Every 6 000 hours (or every three years)
● Every 8 000 hours (or every four years)
● Every 10 000 hours (or every five years)

Note

- The above schedule is based on when the controller is used for arc welding operation.
- Inspection of the product is available as fare-paying service. For details, please contact Panasonic representatives.

9.2 Daily check

◆ Inspections before turning on the power

	Parts	Item	Service	Remarks
1	Ground cable Cables	<ul style="list-style-type: none"> Looseness Breaking or damage of wire 	<ul style="list-style-type: none"> Re-tightening. Replacement 	
2	Manipulator	Adhesion of spatter or dust.	Removal of spatter or dust	Do not blow them off with compressed air. Dust or spatter may enter the clearance or inside of the cover, resulting in damage to the robot.
		Looseness	Re-tightening	Consult our service section if causes are not clear.
3	Safety fence	Damage	Repair	
4	Welding torch nozzle, tip	<ul style="list-style-type: none"> Adhesion of spatter. Wear at the tip hole 	<ul style="list-style-type: none"> Removal of spatter. Replacement 	Be sure to replace with genuine parts.
5	Controller	Adhesion of spatter/dust.	Removal of spatter/dust.	
		Clogged filter.	Clean/replace filter (*)	
6	Working area	Tidiness		

Note

(*) : About filter at the air inlet fan

The air inlet fan at the side panels of the welding power source unit is covered with a filter.

- Clean the filter periodically. And remove dust and/or spatter attached to the filter. Using the controller with clogged filter may reduce its cooling performance of the fan, and performance of the robot will be deteriorated, as a result, the "Temperature error" may occur.
- In case of "Temperature error"(W1210, W1220), check the filter and clean or replace it as necessary. Adhesion of dust to the cooling fan of the built-in welding power unit reduces cooling performance, which, as a result, can cause the "Temperature error". In that case, clean the cooling fan.
(If the error recurs after cleaning the cooling fan, please consult Panasonic representatives.)

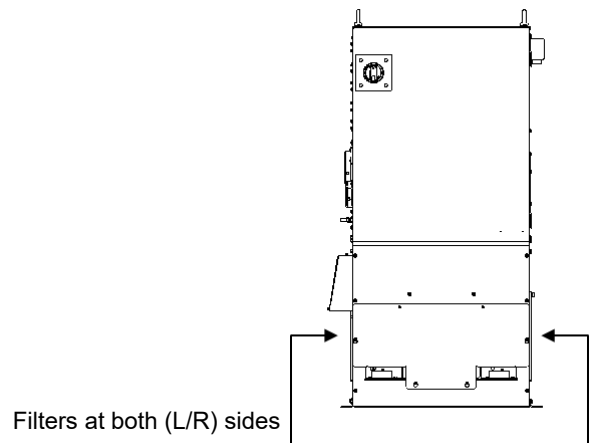

● How to replace filter

- (1) Loosen the fixing screw of the filter fitting. Then open the filter fitting and remove the filter.
- (2) Insert a new filter into the filter fitting, and then close the filter fitting. Then tighten the filter fitting fixing screw.

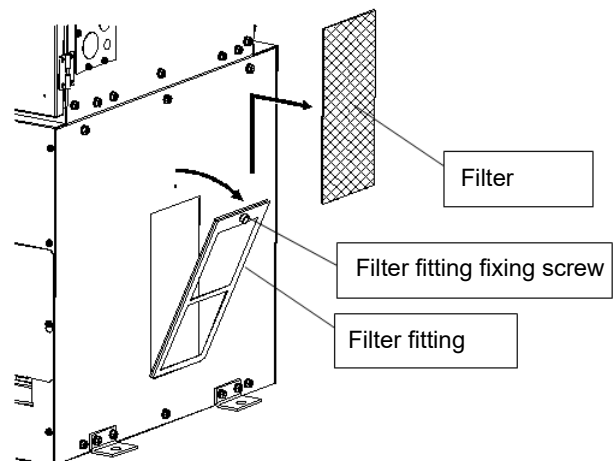

◆ Inspections after turning on the power



CAUTION

Check to confirm that no personnel are present within the robot work envelope before turning on the power.

	Parts	Item	Service	Remarks
1	Emergency stop switch	After turning on the servo power, the servo power goes off immediately after turning on the emergency stop switch.	If not, • Repair • Consult us if causes are not clear.	Do not use the robot unless the switch is repaired.
2	Manipulator	Each axis of the robot makes steady and smooth motions (no abnormal vibration, noise or looseness) in manual and operation mode.	If not, consult us if causes are not clear.	Do not use the robot unless the manipulator is repaired.
3	Fan	Cooling air inlet fan of the controller rotates. No Adhesion of dust on the fan.	If not, clean the fan.	Be sure to turn off the power to the controller before cleaning the fan.
4	Controller	No abnormal vibration, noise or odor from the built-in welding power source	If not, consult us if causes are not clear.	Do not use the robot unless the controller is repaired.

Note

The fan for the built-in welding power source (2 pcs. on the front panel side) may not rotate immediately after power on. It starts rotation with increasing temperature of the built-in welding power source after starting actual operation. It stops rotation when the temperature of the built-in welding power source decreases after stopping actual operation.

9.3 Periodical check

Interval						Item	Inspection and service
3 mth	1 yr.	2 yr.	3 yr.	4 yr.	5 yr.		
○						Screws at covers	Check for looseness and re-tighten if necessary.
○						Connecting cable connectors	Check for looseness and re-tighten if necessary.
○						Other consumable components	Replacement new one if necessary

Note

- Electromagnetic contactors or cooling fans:
Please treat them as consumable when performing periodical check and maintenance work. Those components have a certain life cycle electrically and mechanically.
- For details, please consult our service section. If you have a periodical inspection contract with our company, our periodical inspections will start with a 2 000-hour (annual) inspection.
- For inspection of the manipulator, please refer to the operating instructions of the manipulator.

9.4 Warnings for withstand voltage test and insulation resistance measurement

This product uses semiconductor components such as transistor. Executing withstand voltage test or insulation resistance measurement casually may cause serious physical injury or mechanical failure. In case of necessity, contact our sales distributors or service section.

10. Disposal of this product

After disposal of this product, data in the controller might go to third parties. To prevent this, perform **All Clear** in **Memory clear** menu before disposal. For details, refer to "Operating Instructions [Operation]".

11. Repair Parts List

11.1 Robot controller

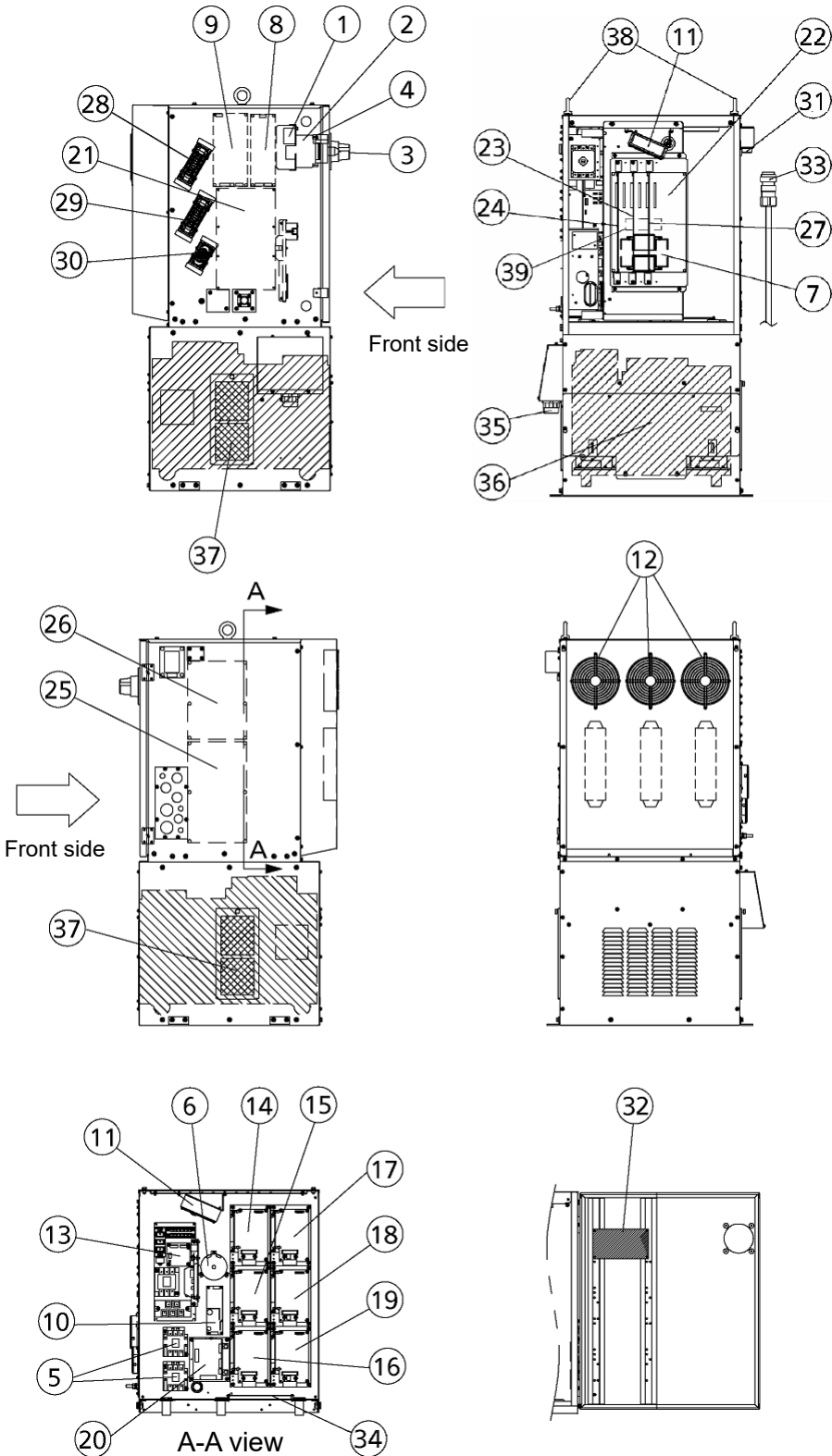

Repair Parts List

No.	Description		Part number	Order number	Q'ty	Note	Safety part	Class
1	Anti-surge Parts		AEB41080	AEB41080	1			D
2	Breaker	T/Y Spec.	B50AA3P50WAR	YABD261	1		○	C
		E Spec.	MTNC000024AA	MTNC000024AA	1		○	C
		R Spec.	MTNC000040AA	MTNC000040AA	1		○	C
3	Handle		BZ6V10D	YAB113	1			C
4	Terminal cover		BW9BTAAS3W	YAB114	1	• 2 pcs/set • Attach to breaker.		D
5	Magnetic switch		SDN50DC24V	YAB182	2			C
6	Electrolytic capacitor		MTNE000187AA	MTNE000187AA	1			C
7	Transformer		UTU5314	UTU5314	1			D
8	DC Power Supply		S8EXBP15024	YAB221	1			C
9	DC Power Supply		ZWQ130-5224L	YAB130	1			C
10	DC Power Supply		MTNC000728AA	MTNC000728AA	1	T/Y Specification		C
			LFA75F15J1	YAB119	1	E/U(R) Specification		C
11	Cooling Fan		UT125C	YKAD34	2			B
12	Cooling Fan		UF15PC20BTH	UF15PC20BTH	3			B
13	Servo Power		AED01306	AED01306	1			C
14 15 16 17 18 19	Amplifier	YA-1WC801***	AED01335	AED01335	3	For RT, UA, FA		C
			AED01336	AED01336	3	For RW, BW, TW		C
		YA-1WC201***	AED01335	AED01335	2	For RT, UA		C
			AED01337	AED01337	1	For FA		C
			AED01340	AED01340	1	For RW		C
			AED01341	AED01341	2	For BW, TW		C
20	Feeder Amplifier		AED01291	AED01291	1	For feeder (50 W)		C
			AED01284	AED01284	1	For feeder (100 W)		C
			AED01285	AED01285	1	For feeder (150 W, 200 W)		C
21	Power Card		ZUEP5880	ZUEP5880	1			C
22	Backplane card		ZUEP5806	ZUEP5806	1			C
23	Main CPU Card		ZUEP5796	ZUEP5796	1			C
24	Servo CPU Card		ZUEP5845	ZUEP5845	1			C
25	Sequencer Card	T/Y/R spec.	ZUEP5789	ZUEP5789	1	Open collector output		C
		E spec.	ZUEP5826	ZUEP5826	1	Open emitter output		C
26	Safety Card		ZUEP5808	ZUEP5808	1			C
27	Welding Control Card		ZUEP5799	ZUEP5799	1			C
28	Motor panel harness1		WSAWC00061	WSAWC00061	1			C
29	Motor panel harness2		WSAWC00062	WSAWC00062	1			C
30	RE panel harness		AWC32937	AWC32937	1			C
31	TP harness		AWC32875	AWC32875	1			C
32	Break release card		ZUEP5883	ZUEP5883	1			C

No.	Description		Part number	Order number	Q'ty	Note	Safety part	Class
33	TP Cable		AWC32876LT	AWC32876LT	1	Standard: 10 m Various lengths are available up to 30 m. For details, please contact Panasonic representatives.		B
34	Welding Power Card		ZUEP5779_A1 ^(*1)	ZUEP5779_A1 ^(*1)	1			C
			ZUEP5905_A1 ^(*1)	ZUEP5905_A1 ^(*1)	1	For 200 W pull feeder type		C
35	Cord lock		EBG2836BK	YAAD62	1			D
36	Welding Power Unit ^(*2)	T/Y Spec.	YA-1TD351T00	AEU01590	1	200 VAC / 220 VAC		C
		E Spec.	YA-1TD351E01	WSAEU00019ZZ	1	200 VAC		C
		R Spec.	YA-1TD351U01	WSAEU00018ZZ	1	200 VAC		C
37	Filter		AKC41124	AKC41124	2			C
38	Eyebolts ^(*3)		XVN12FJ	XVN12	2	M12		B
39	DC Power Supply		S8EXN01515	YAB226	1	YA-1WC201*** only		C

(*1) When you order a card, make sure to use the complete repair part order number including the alphanumeric characters at the end, such as A1 and B1, if any.

The card of the part number without the alphanumeric characters is not compatible with the one with the alphanumeric characters.

The underline “_” in a part number if any represents any give alphanumeric character.

(*2) Replacement of the welding power unit is available only by unit.

(*3) Eyebolts are important safety parts. When they are lost or broken, purchase Panasonic genuine eyebolts for your safety.

<Class> A: Consumable parts, rather short replacement cycle.
 B: Assemblies and parts of high frequency in motion.
 C: Important electric parts.
 D: Parts rather long replacement cycle.

◆ List of fuses (Safety parts)

No.	Installation location	Part code	Part number	Order number	Q'ty	Note
1	AED01306 (ZUEP5837)	F1, F2	ST4-0.5A	YZAD179	2	0.5 A (Open-phase card)
2	ZUEP5789 (T/Y/R) ZUEP5826 (E)	F1	ST4-3AN1	YZA/EEJ002	1	3 A (Sequencer card)
3	ZUEP5808	F1	ST4-3AN1	YZA/EEJ002	1	3 A (Safety card)
4	ZUEP5880	F3, F4	ST4-8AN1	YZAD217	2	8 A (Power card)
5	ZUEP5880	F2	ST4-2AN1	YZAD181	1	2 A (Power card)
6	ZUEP5880	F1	CES14-12AN2	YABD264	1	12 A (Power card)
7	ZUEP5755	F1	ST4-5AN1	YZAD183	1	5 A (Welding Power Unit)
8	Fuse holder	F4,F5,F6	ST4-3AN1	YZA/EEJ002	3	3 A (Welding Power Unit)

11.2 Teach pendant

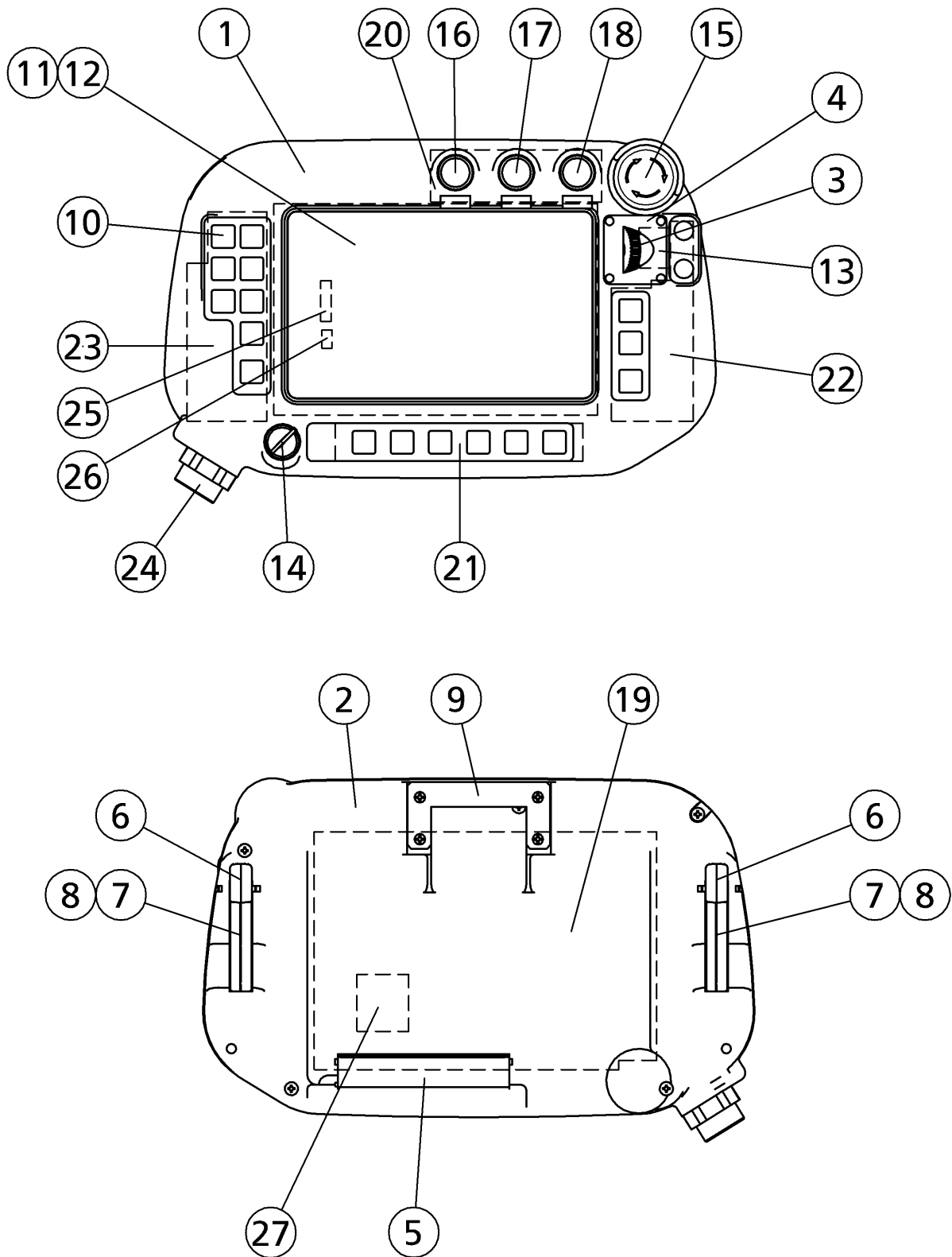

No.	Description	Part number	Repair parts order number	Q'ty	Note	Safety part	Class
1	Upper Case	AKC21007	AKC21007	1			D
2	Lower Case	AKC21008	AKC21008	1			D
3	Dial	AKC31006	AKC31006	1			D
4	Jog cover	AKC31061	AKC31061	1			D
5	Cover	AKC31060	AKC31060	2			B
6	Trigger	AKC31009	AKC31009	2			B
7	Lever 1	AKC31002	AKC31002	2			B
8	Lever 2	AKC31003	AKC31003	1			D
9	TP hanger	AKC41238	AKC41238	1			B
10	Key Sheet	AKP32009	AKP32009	1	A set of three kinds.		B
11	LCD Cover	AKK32082	AKK32082	1			B
12	LCD	MTNS000067AA	MTNS000067AA	1			B
13	Encoder	RE21BARE100A	YABD209	1			B
14	Key Switch	AS6M2KT2PA	YAB120	1	With 2 keys (YAB178)		B
15	Emergency Stop Switch	XA1EB3U02TR	YAB224	1		O	B
16	Push button switch	A165TGYMNA1	YABD40	1			B
17	Push button switch	A165TWMNMA2	YAW173	1			B
18	Push button switch	A165TGYMNA3	YAB122	1			B
19	TP CPU Card	ZUEP5800	ZUEP5800	1			C
20	TP UP card	ZUEP5716	ZUEP5716	1			C
21	TP Low Card	ZUEP5811	ZUEP5811	1			C
22	TP Right Card	ZUEP5810	ZUEP5810	1			C
23	TP Left Card	ZUEP5809	ZUEP5809	1			C
24	TP harness	AWC32878	AWC32878	1			B
25	TP LCD harness	AWC42538	AWC42538	1			D
26	TP LED harness	AWC42537	AWC42537	1			D
27	SD memory card	RPSDFC51WE0	YABD290	1			B

<Class> A: Consumable parts, rather short replacement cycle.
 B: Assemblies and parts of high frequency in motion.
 C: Important electric parts.
 D: Parts rather long replacement cycle.

11.3 Operation Box

T / Y spec.	Optional
E / R spec.	Standard

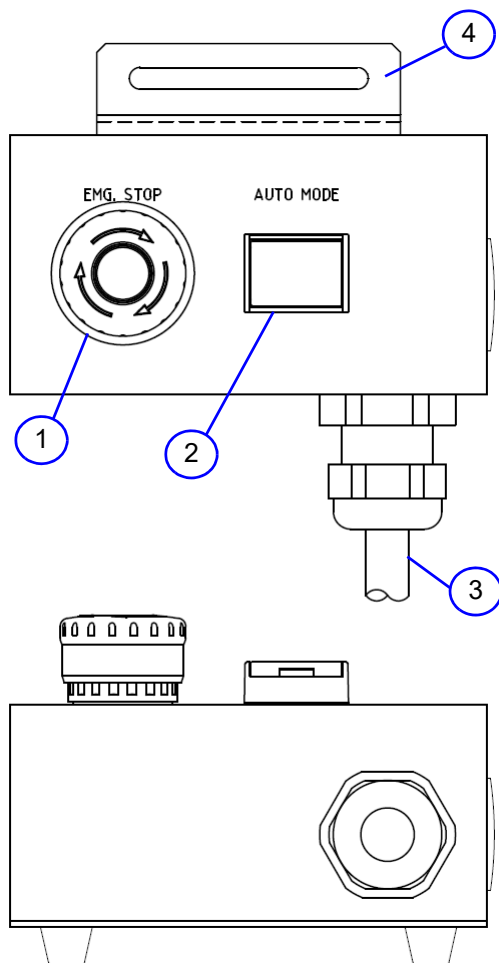

<Class> A: Consumable parts, rather short replacement cycle.
 B: Assemblies and parts of high frequency in motion.
 C: Important electric parts.
 D: Parts rather long replacement cycle.

No.	Description	Part number	Repair parts order number	Q'ty	Note	Class	Safety part
-	Operation box	AEU01610	AEU01610	1		D	
1	Emergency Stop Switch	XA1EB3U02TR	YAB224	1		B	Yes
2	Push Button Switch	A165LJWM24DN	YABD204	1		B	
3	Cable	AWC32923LP	AWC32923LP	1	6 m	B	
4	Fixing Metal	AKC41016PA	AKC41016PA	1		D	

Note

Safety parts are important for safe machine operation.
 Always use correct parts in correct locations.

12. Critical Raw Material (CRM) List

CRM	Description	Part number	Note
Light Rare Earth Elements	Motor	TS4602N3030	Included in feeder (50 W).
		TS4606N3337	Included in feeder (100 W).
		TS4604N3022	Included in feeder (150 W).
		MTNM000185AA	Included in feeder (200 W).

13.2 Controller 2

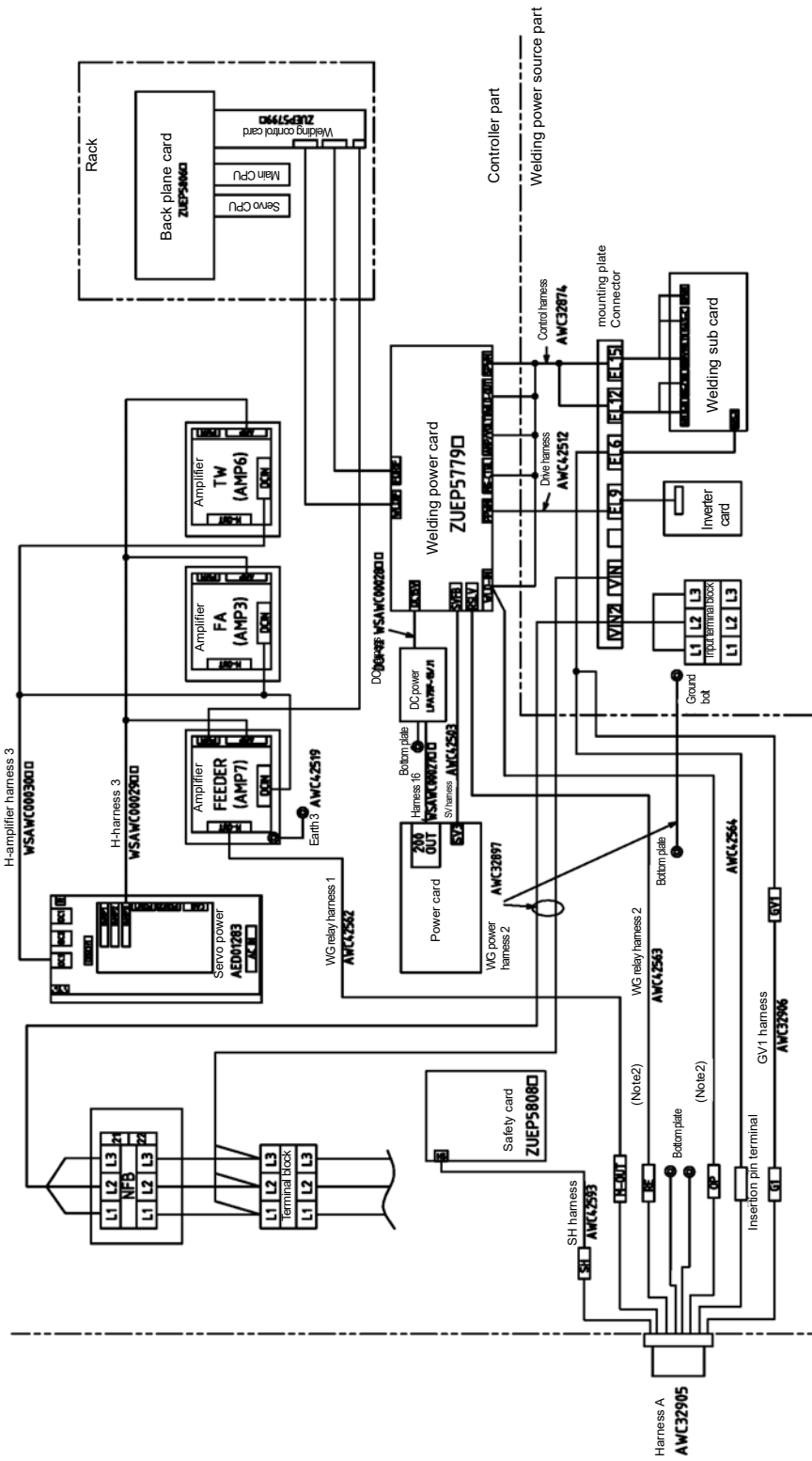

(Note2) Connect clamp filters to WLD-IN (ON) and RSLV (RE) as shown below.

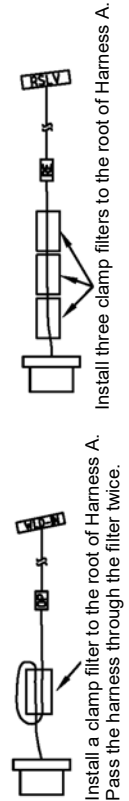

13. 4 For YA-1WC201***

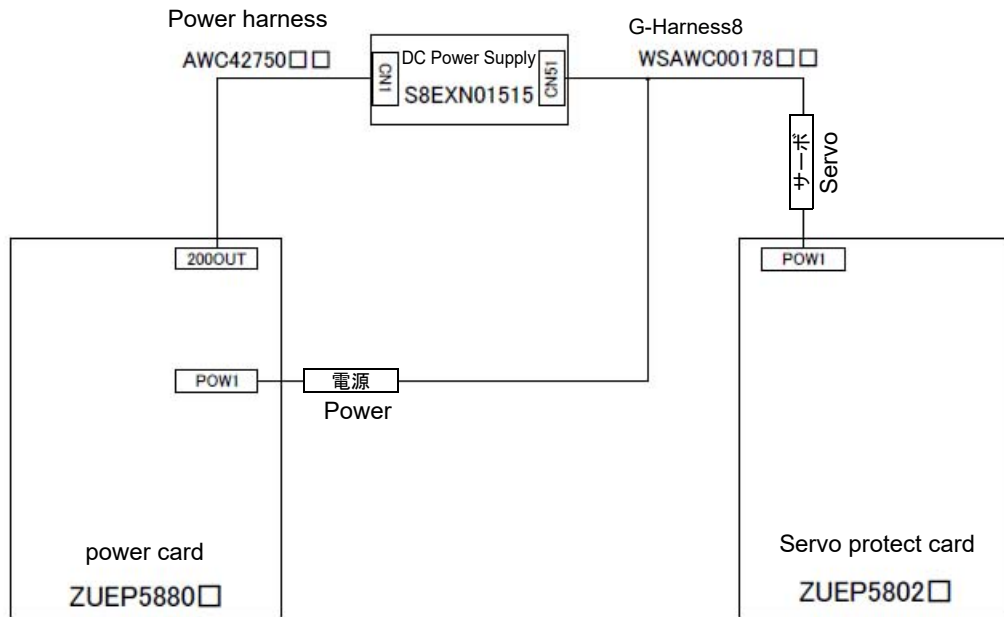

14. Labels

14.1 Label locations

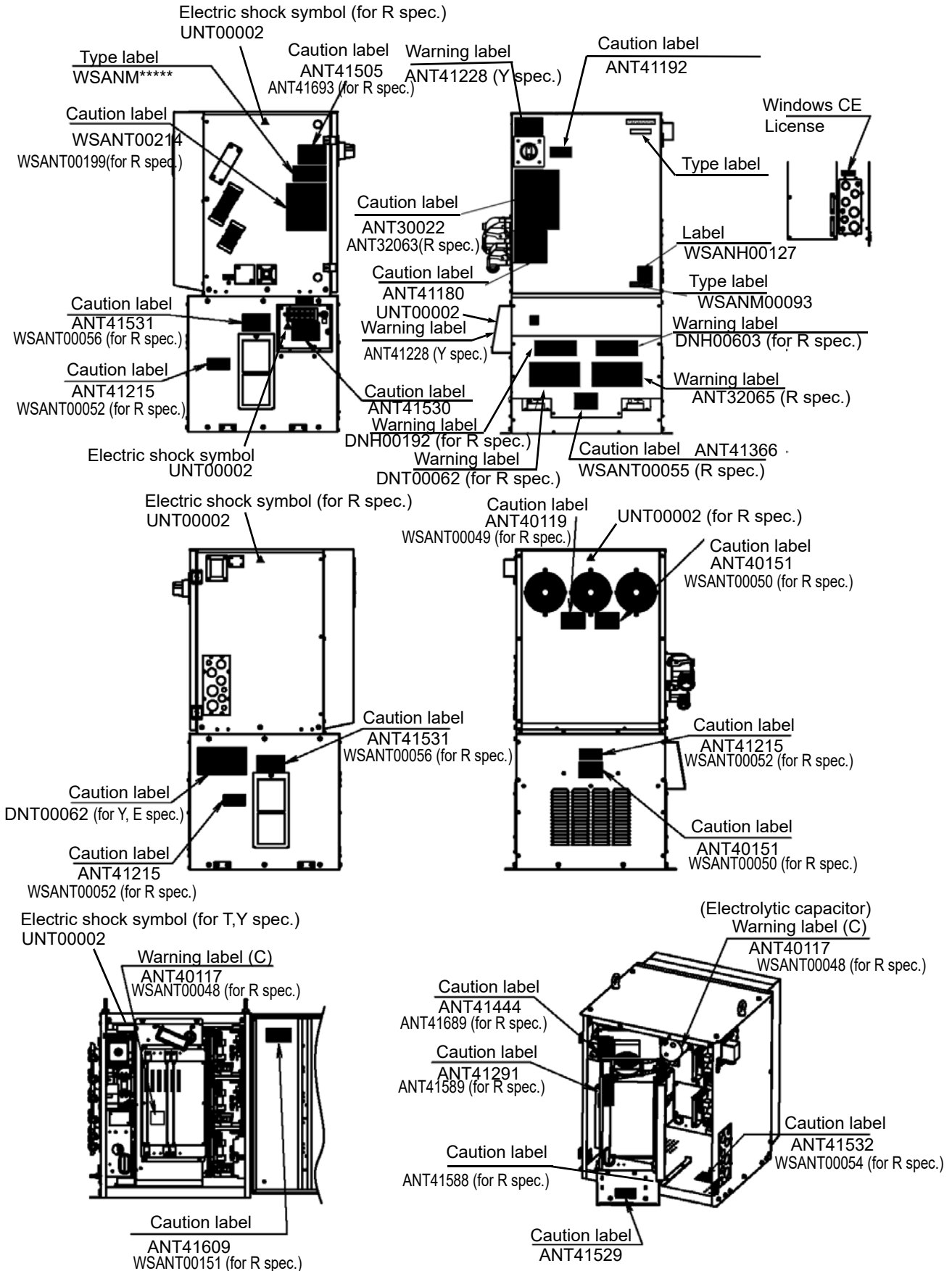

- Only for E/R specifications

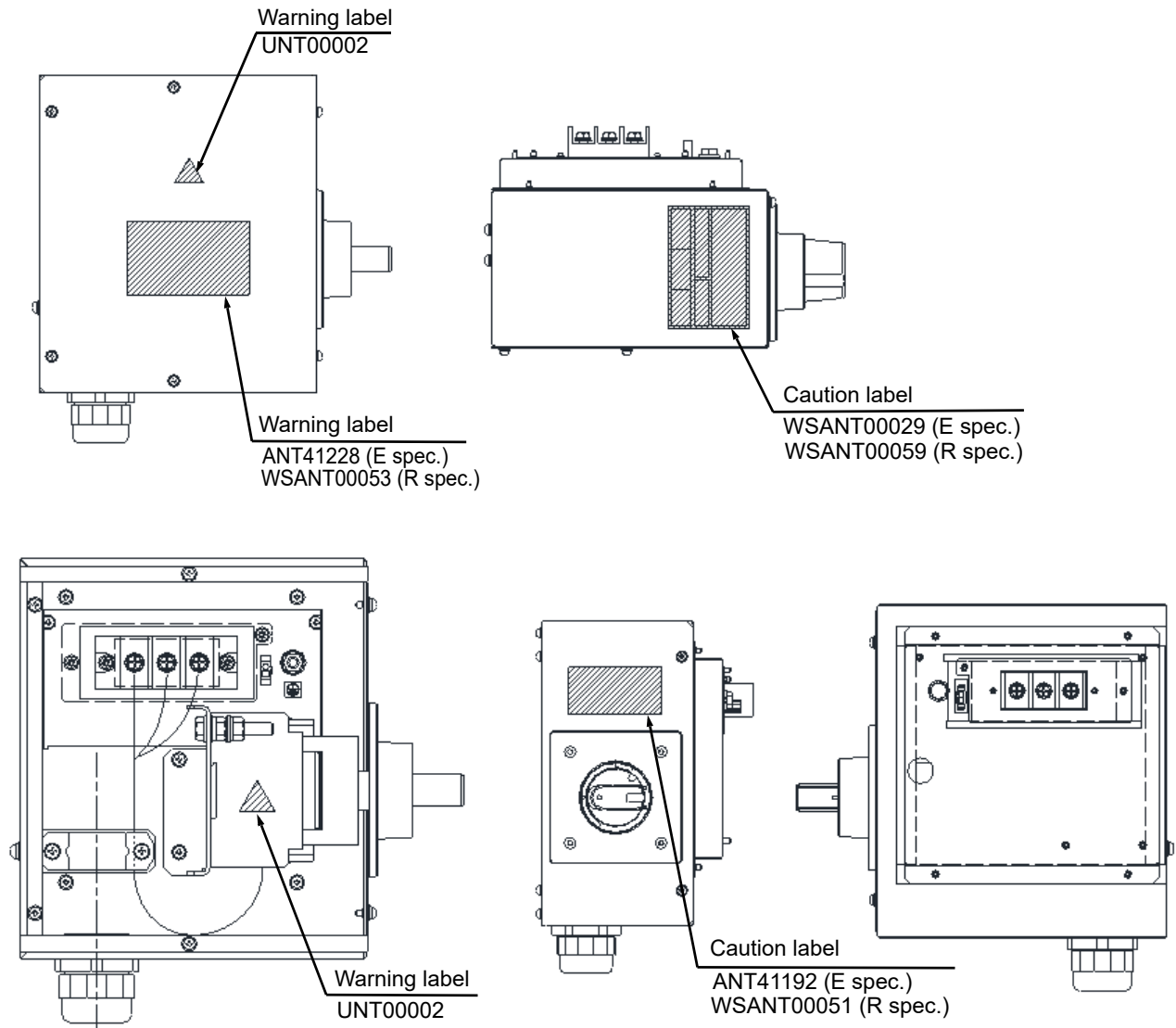

14.2 Label details



<Type label - WSANM00093>

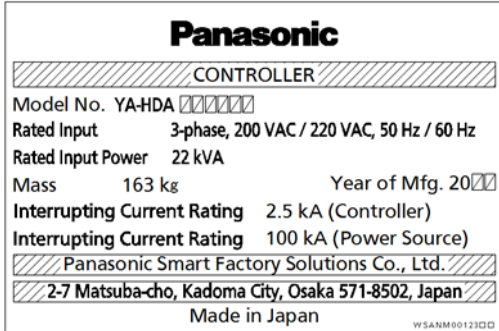

<Type label - WSANM00123>
(Y spec. only)

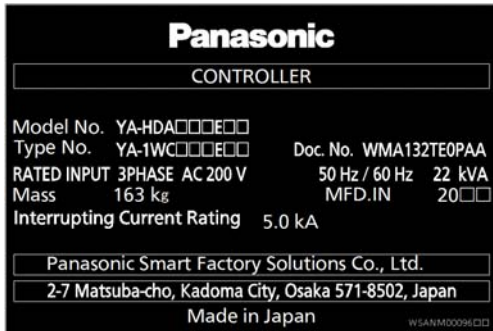

<Type label - WSANM00096>
(E spec. only)



<Type label - WSANM00096>
(R spec. only)



< Caution label - ANT40151 >

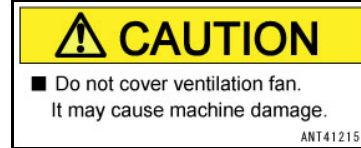

< Caution label - ANT41215 >

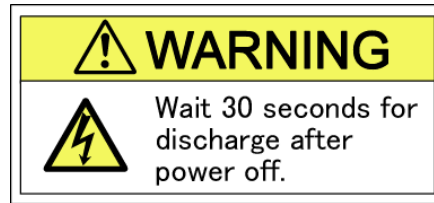

< Warning label - ANT40117 >

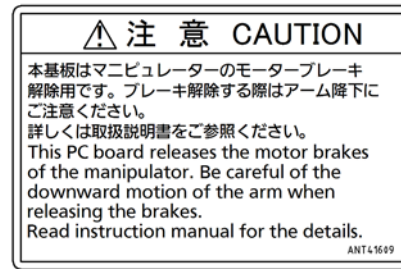

< Caution label - ANT41609 >

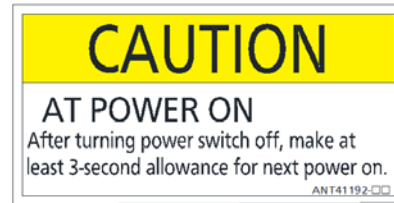

< Caution label - ANT41192 >

⚠ CAUTION	⚠ 注意
<p>GROUNDING</p> <ul style="list-style-type: none"> Make reliable ground connection for the robot independently from the protective earth terminal of the robot controller. Use protective conductor more than AWG #6 (14 mm). As for thickness of protective conductor for another machine, follow indication for each machine. Grounding work must be done by the qualified personnel. <p>DAILY CHECK</p> <ul style="list-style-type: none"> Check looseness and disconnection of protective conductor. 	<p>接地工事</p> <ul style="list-style-type: none"> 制御装置の保護接地端子にロボット単独でD種接地工事を行って下さい。 保護接地線は14 mm以上の線をご使用下さい。 他の装置の保護接地線の太さは、その装置の手順に従って下さい。 D種接地工事は、必ず専門の電気工士により施工して下さい。 <p>保護接地線の日常点検</p> <ul style="list-style-type: none"> 保護接地線は日常点検し、はずれたり、断線したりしていないか確認して下さい。
<p>EARTH LINE OF FACTORY 工場の保護接地線</p>	

< Caution label - WSANT00214 >

⚠ WARNING

Carefully read operation manual before installation

⚠	Do not open the door. Electric shock can kill.
⚠	Do not enter the robot work envelope while robot is operating.

⚠ CAUTION

Encoder backup battery
Replace battery every 2 years.
Operating conditions will vary the lifetime of battery.
Refer to operation manual.

< Warning label - ANT30022 >

⚠ CAUTION

- Make sure to install the robot controller so that no spatters or flammable substances can get in through the air inlet. Read instruction manual for the details.
- Clean the filter attached to the air inlet of the fan periodically
- In case of "temperature error", check the filter and clean or replace as necessary

ANT41531-□□

< Caution label - ANT41531 >

Model No. YA-H□A□□□□□□□□
Code No. YA-1□C□□□□□□□□

本コントローラは下記シリアルナンバーのマニピュレータと接続してご使用ください。

Connect this controller to the manipulator with the following serial number.

Serial Number :
□□□□-□□□□-□□□□

WSANH00127

< Label: WSANH00127 >



< CE mark - ANH42332 >

⚠ CAUTION

Before opening the rack, be sure to disconnect four connectors (TPOW, TCOM, CAN0, CAN1) on the upper right of the backplane board.

Connectors location of the backplane board

ANT41529-□□

< Caution label - ANT41529 >

⚠ CAUTION

During maintenance work, the movement of the rack may cause damage of wire harnesses. Don't place wire harnesses or other parts on the left side of this label.

ANT41532-□□

< Caution label - ANT41532 >

⚠ 注意

挟み込み注意
手を入れるな。

⚠ CAUTION

RISK OF GETTING TRAPPED
do not insert hands

< Caution label - ANT41291 >

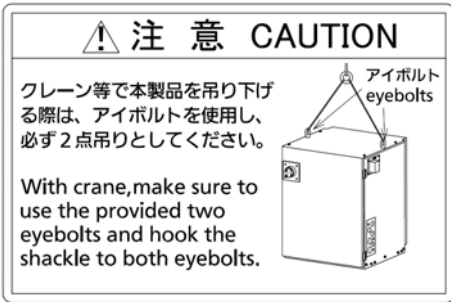

< Caution label - ANT41505 >



< Caution label - ANT41444 >

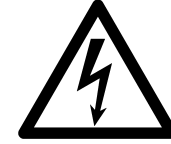

< Electric shock symbol - UNT00002 >

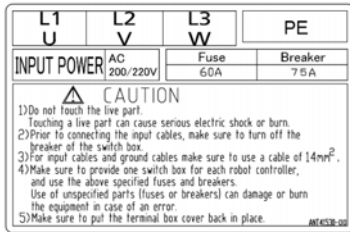

< Caution label - ANT41530 >
(Y spec. only)

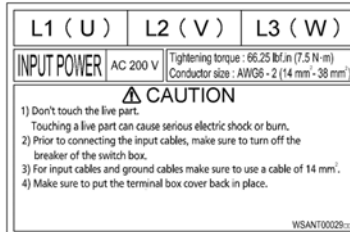

< Caution label - WSANT00029 >
(E spec. only)



< Caution label - WSANT00059 >
(R spec. only)

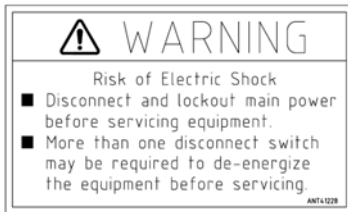

< Warning label - ANT41228 >



< Caution label - ANT40119 >

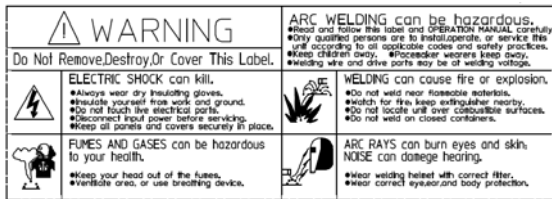

< Warning label - DNT00062 >

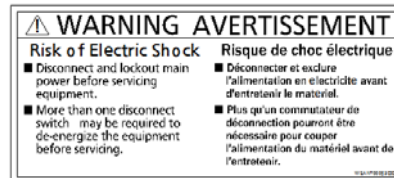

< Warning label - WSANT00053 >
(R spec. only)

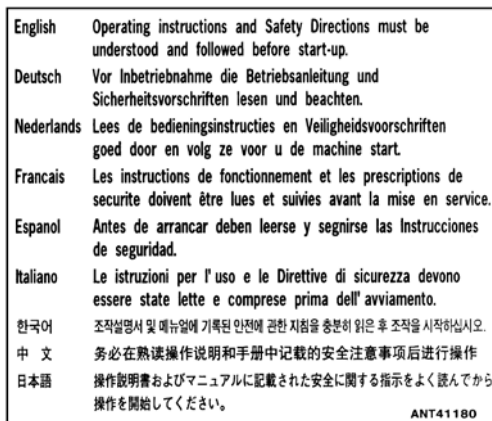

< Caution label - ANT41180 >



< Caution label - WSANT00051 >
(R spec. only)

	CAUTION ATTENTION
<ul style="list-style-type: none"> Make sure to install the robot controller so that no spatters or flammable substances can get in through the air inlet. Read instruction manual for the details. Clean the filter attached to the air inlet of the fan periodically. In case of "temperature error", check the filter and clean or replace as necessary Placez l'armoire de commande de telle façon à ce que les substances inflammable ne puissent pas rentrer par l'entrée de la ventilation. Lisez le manuel d'instruction pour plus d'information. Nettoyer le filtre attaché à l'entrée de l'air du ventilateur périodiquement. En cas de "temperature error" contrôlez le filtre et nettoyez ou changez le si nécessaire. 	
<small>WSANT00056</small>	

< Caution label - WSANT00056 >
(R spec. only)

	CAUTION ATTENTION
<ul style="list-style-type: none"> Do not cover ventilation fan. It may cause machine damage. Ne pas couvrir le ventilateur. Cela peut endommager la machine. 	
<small>WSANT00052</small>	

< Caution label - WSANT00052 >
(R spec. only)

WARNING	AVERTISSEMENT
Carefully read operation manual before installation.	Lire attentivement le manuel d'opération avant installation.
Arc Flash and Shock Hazard Do not open the door Risk of electric shock	Risque de coup d'arc et de choc Ne pas ouvrir la porte. Risque de choc électrique.
Do not enter the robot work envelope while robot is operating.	Ne pas entrer dans la zone de travail du robot pendant qu'il est active
CAUTION	ATTENTION
Encoder backup battery Replace battery every 2 years Operating conditions will vary lifetime of battery Refer to operation manual.	Batterie de sauve-garde d'encodeur Remplacer la batterie toutes les 2 ans Conditions d'opérations font varier la durée de vie de la batterie. Référer au manuel d'opération.
<small>417,262,000</small>	

< Warning, Caution label - ANT32063 >
(R spec. only)

	AVERTISSEMENT
<p>UN CHOC ELECTRIQUE peut être mortel.</p> <ul style="list-style-type: none"> Installation et raccordement de cette machine doivent être conformes à tous les codes pertinents. <p>SOUDAGE A L'ARC peut être hasardeux.</p> <ul style="list-style-type: none"> Lire le manuel d'instructions avant utilisation. Ne pas installer sur une surface combustible. Les fils de soudage et pièces conductrices peuvent être à la tension de soudage. 	
<p>Read American National Standard Z49.1, "Safety In Welding and Cutting," from American Welding Society, 550 N.W. LeJeune Rd., Miami, FL 33126; OSHA Safety and Health Standards, 29 CFR 1910, from U.S. Government Printing Office, Washington, D.C. 20402.</p>	

< Warning label - DNH00192>
(R spec. only)

	AVERTISSEMENT	<p>SOUDAGE À L'ARC peut être dangereux.</p> <ul style="list-style-type: none"> Lire et suivre cette étiquette et le manuel d'opération attentivement. Seulement les personnes qualifiées peuvent installer, opérer ou entretenir cette unité conforme aux codes et pratiques de sécurité appliqués. Tenez les enfants à l'écart. Porteurs de pacemaker, tenez-vous à distance. Fil de soudage et pièces d'alimentation peuvent être sous tension de soudage.
<p>Ne pas enlever, détruire ou camoufler cette étiquette.</p>		
<p> Décharge électriques peut provoquer la mort.</p> <ul style="list-style-type: none"> Toujours porter des gants isolants secs. Isoler vous du produit et de la masse. Ni pas toucher des pièces électriques connectées. Déconnecter l'alimentation en électricité avant d'entretenir le matériel. Placer toutes les panneaux et protections en place. 	<p> Soudage peut causer du feu ou une explosion.</p> <ul style="list-style-type: none"> Ne pas souder dans les environs de produits inflammables. Faites attention au feu; garder un extincteur dans les environs. Ne pas positionner l'unité au dessus des surfaces combustibles. Ne pas souder sur des conteneurs fermés. 	
<p> Fumées et gazes sont dangereuses pour votre santé.</p> <ul style="list-style-type: none"> Éloigner votre tête hors des fumées. Ventiler l'espace, ou utiliser un équipement respiratoire. 	<p> ARCS DE SOUDURE peuvent bruler les yeux et la peau. Bruit peut endommager l'audition.</p> <ul style="list-style-type: none"> Porter un casque de soudure avec le filtre approprié. Porter des protections correctes pour les yeux, les oreilles et le corps. 	

< Warning label - ANT32065>
(R spec. only)

	CAUTION ATTENTION
<p>Turn power OFF control equipment before connecting output cable. Install this terminal cover after connecting output cable.</p>	<p>Coupez l'appareillage de commande avant de brancher le câble de sortie. Placez à nouveau le couvercle après le branchement du câble de sortie.</p>
<small>WSANT00055</small>	

< Caution label - WSANT00055 >
(R spec. only)

	WARNING
<p> AN ELECTRICAL SHOCK can be mortal.</p> <ul style="list-style-type: none"> Installation and connection of this machine should be conform to all appropriate codes. <p>ARC WELDING can be hazardous.</p> <ul style="list-style-type: none"> Read the instruction manual before use. Do not install on a combustible surface. Welding wire and conductive parts can carry the welding voltage. 	<p>Lire American National Standard Z49.1, "Safety In Welding and Cutting," from American Welding Society, 550 N.W. LeJeune Rd., Miami, FL 33126; OSHA Safety and Health Standards, 29 CFR 1910, from U.S. Government Printing Office, Washington, D.C. 20402.</p>

< Warning label - DNH00603 >
(R spec. only)

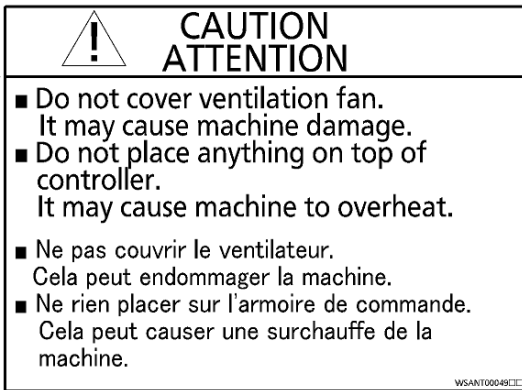

< Caution label - WSANT00049 >
(R spec. only)



< Caution label - ANT41689 >
(R spec. only)

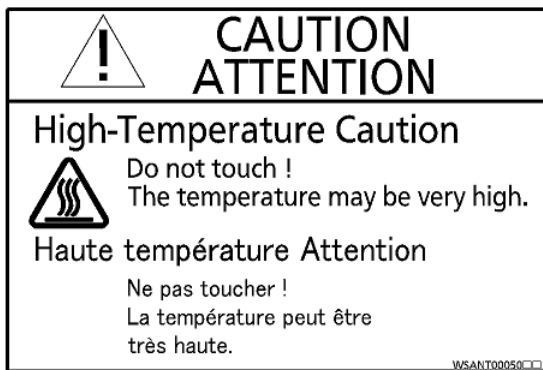

< Caution label - WSANT00050 >
(R spec. only)



< Caution label - ANT41589 >
(R spec. only)

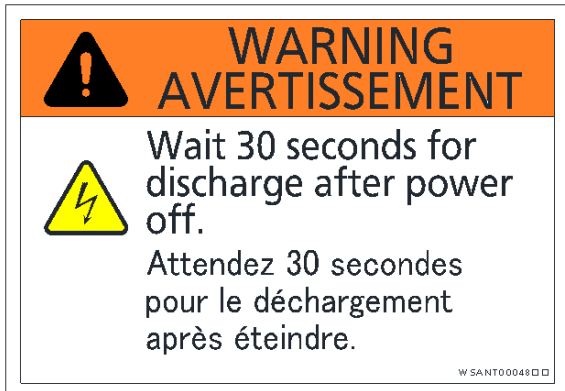

< Warning label - WSANT00048 >
(R spec. only)

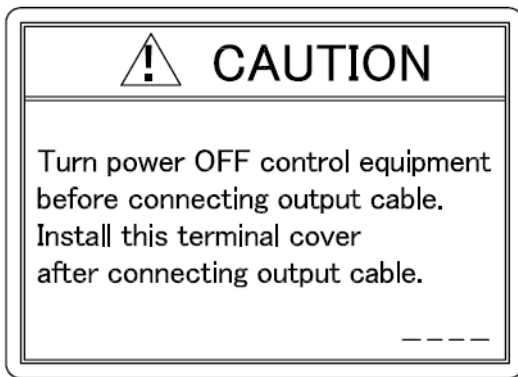

< Caution label - ANT41366 >

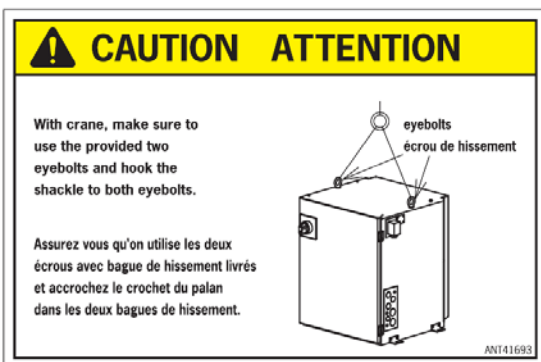

< Caution label - ANT41693 >
(R spec. only)

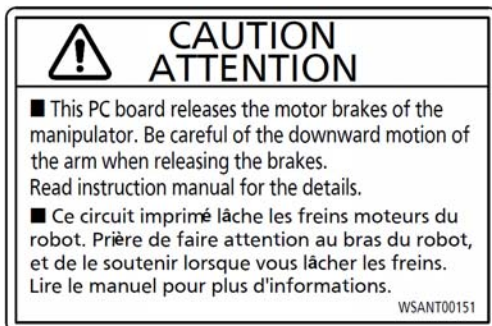

< Caution label - WSANT00151 >
(R spec. only)

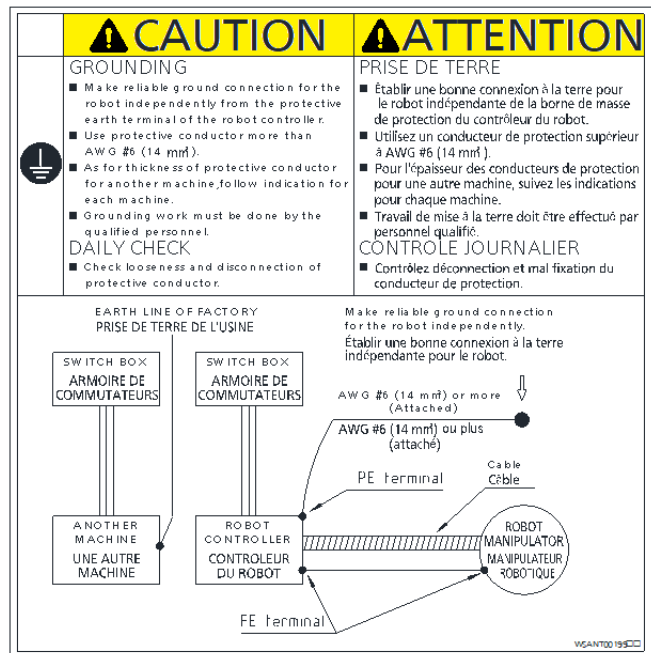

< Caution label - WSANT00199 >
(R spec. only)

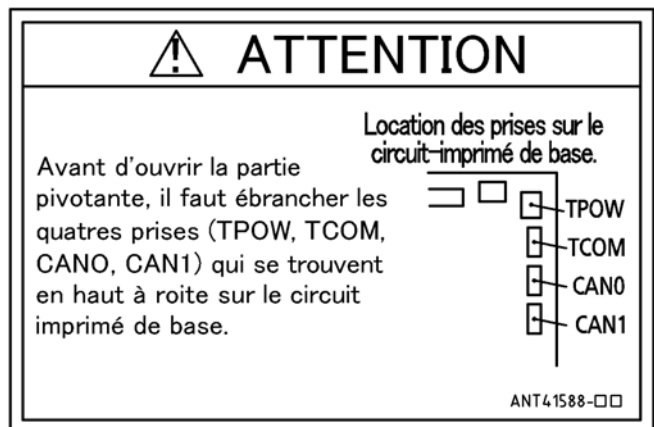

< Caution label - ANT41588 >
(R spec. only)

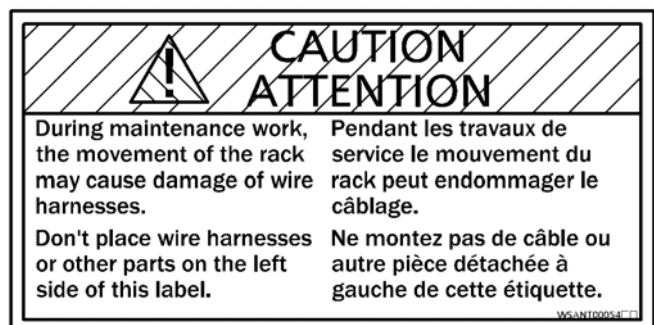

< Caution label - WSANT00054 >
(R spec. only)

パナソニック スマートファクトリーソリューションズ株式会社

〒571-8502 大阪府門真市松葉町2番7号

Panasonic Smart Factory Solutions Co., Ltd.

2-7 Matsuba-cho, Kadoma City, Osaka 571-8502, Japan

© Panasonic Smart Factory Solutions Co., Ltd. 2017

Printed in Japan

WMA132TE0PAA07