

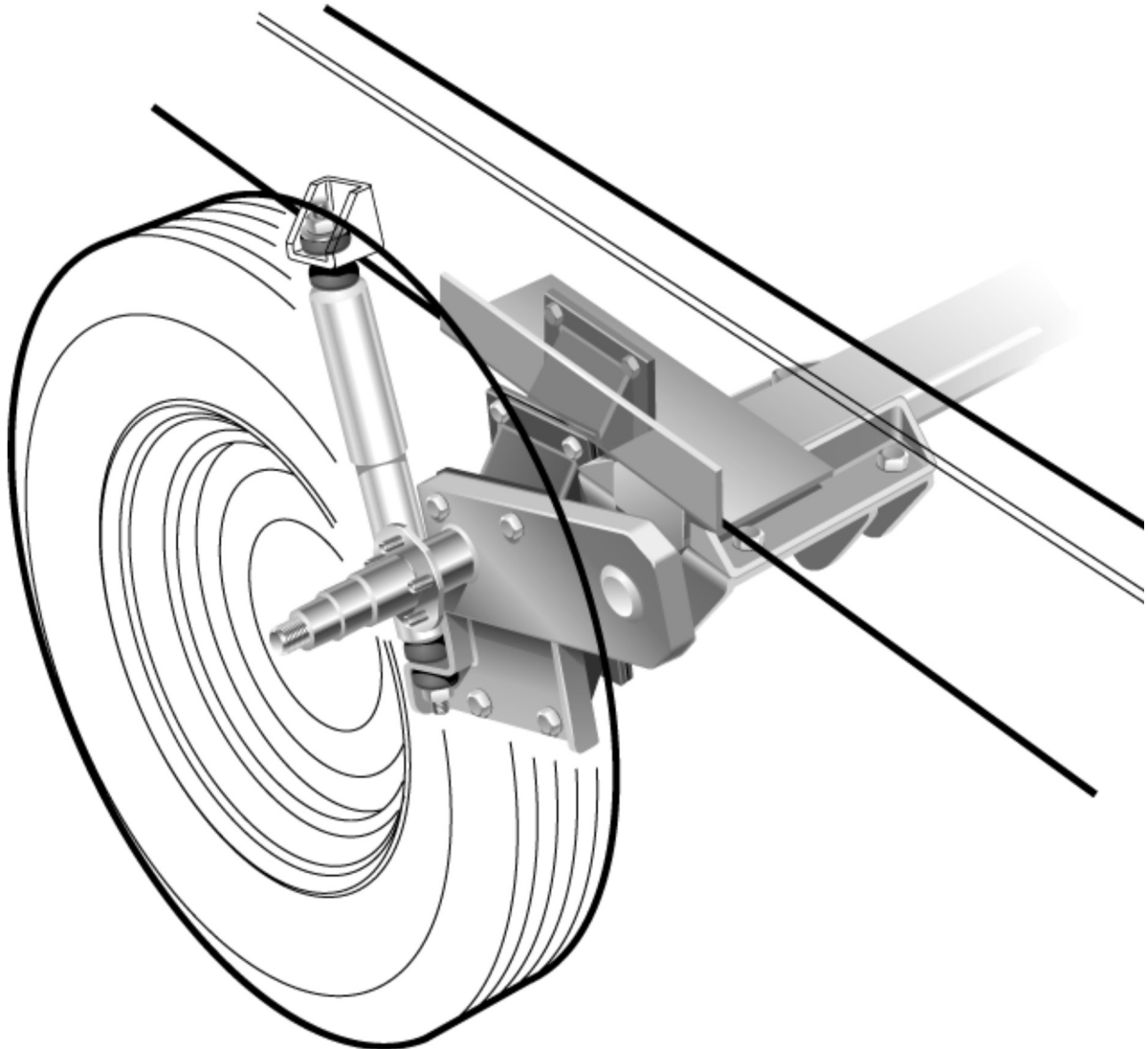

Above. Beyond. Always.

Independent Suspension System Service Manual



Independent Suspension System

CONTENTS

INTRODUCTION.....	2
MAINTENANCE.....	3
SERVICE.....	3-5
SUSPENSION ALIGNMENT.....	5
TROUBLE SHOOTING AND TORQUE CHART.....	6-7

INTRODUCTION

DESCRIPTION

The MORryde "IS" Independent Rubber Suspension System uses 100% Natural Rubber Springs to support the trailer weight and absorb road shock. By absorbing the shock, the rubber provides a much smoother towing experience than steel leaf springs. With the new MORryde "IS" Independent Rubber Suspension System, there are no more broken leaf springs! The towing is virtually hassle-free with the smoothest towing available for fifth wheels and travel trailers.

The Primary benefits that you can expect from the MORryde "IS" suspension are:

SMOOTHER TOWING - the MORryde suspension has up to 2 1/2 times the suspension travel of leaf springs or rubber axles, allowing the MORryde suspension to absorb road shock much better.

IMPROVED TOWABILITY - the MORryde suspension is designed to "block" body roll, improving the cornering and stability of the tow vehicle and trailer combination.

AUTOMOTIVE STYLE ALIGNMENT - a MORryde first! You can manage your tire wear through toe and camber adjustments, a feature no other towable suspension offers!

HEIGHT ADJUSTABILITY - the MORryde suspension can be adjusted easily to accommodate different tow heights and to compensate for side-to-side load variations.

PROVEN DURABILITY - the MORryde suspension has undergone strenuous testing to prove it's durability. The result? No more broken leaf springs!

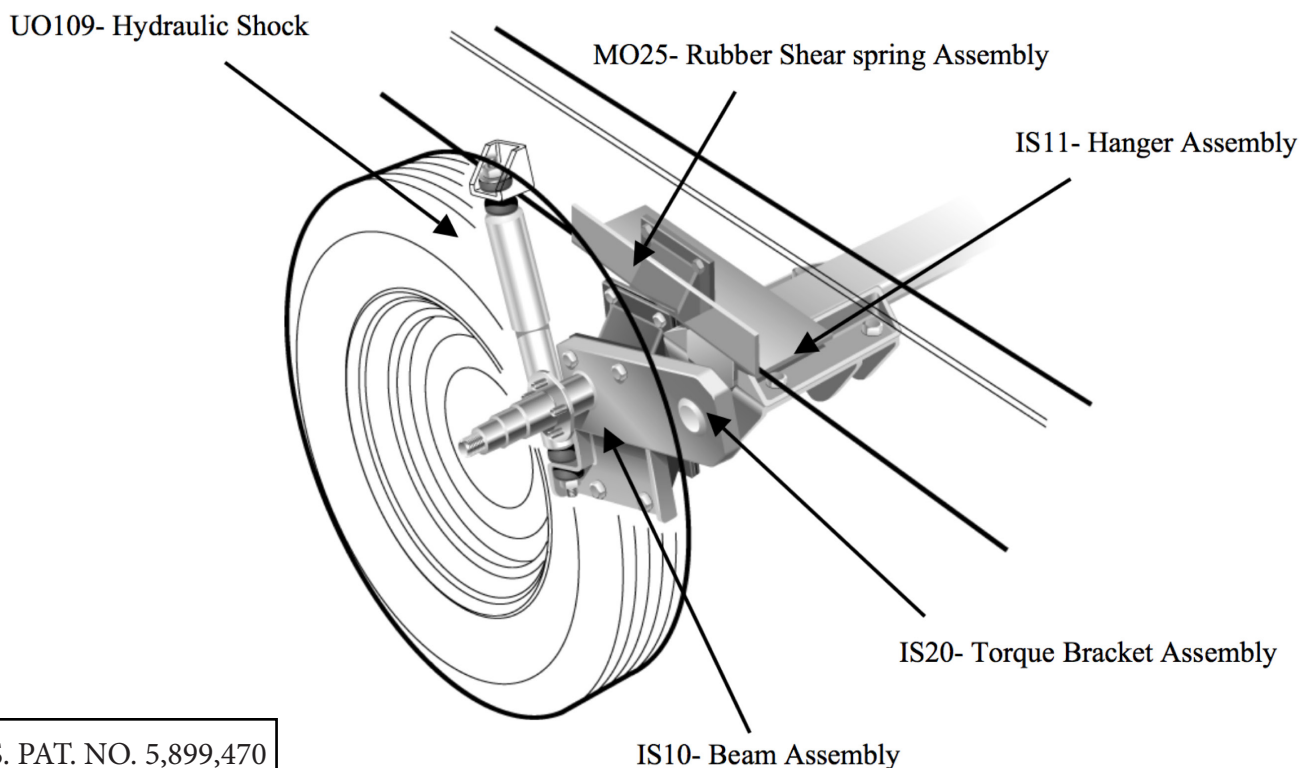

U.S. PAT. NO. 5,899,470

MAINTENANCE

Maintenance to the MORryde “IS” suspension system is minimal. For service information regarding bearing options or braking systems on your trailer, please consult the appropriate brake/axle manufacturer.

LUBRICATION

After November of 2001, the “IS” journal shaft will have a grease zerk on the under side of the “IS” torque bracket. It should be greased every 12 months or 6000 miles.

SHOCK ABSORBER MAINTENANCE

The shock absorbers used on the MORryde “IS” rubber suspension are sealed, hydraulic type and require no periodic maintenance. Shock absorbers of this type should be checked every 10,000 miles to make sure they are functioning satisfactorily, bushings are not worn, and the dust cover has not been damaged by flying stones or debris from the road. If a shock absorber is leaking, fails to operate, or develops an unusual noise, the shock absorber should be replaced.

SERVICE

NOTE: ALL SERVICE PROCEDURES MUST BE PERFORMED WITH THE VEHICLE SUPPORTED AT THE FRAME WITH APPROPRIATELY RATED SAFETY STANDS AND JACKS.

PROCEDURES FOR JACKING UP UNIT

It is permissible to jack up a unit equipped with a MORryde Independent Rubber Suspension System only on the Beam Assembly under the Rubber Springs or the frame of the trailer. The most efficient location to raise a trailer is at the frame. Jacks and safety stands should be positioned towards the front and rear portion of the trailer frame. To perform suspension work tires should be approximately 4” above the ground.

INSPECTION/REPLACEMENT OF RUBBER SPRINGS

MORryde rubber springs are made of a special formulation of natural rubber. The rubber springs are vulcanized (bonded) to steel plates. There are two unlikely problems that may occur with MORryde rubber springs:

1. The first type is bond failure. This condition is apparent when the rubber separates from the metal plate.
2. The second type is a rubber failure. This condition is apparent when the rubber tears or delaminates and generally occurs in the middle of the rubber spring between the metal plates.

Either of the conditions described above would not always necessitate replacement of the rubber spring. If there is a question about the integrity of a marginal rubber spring, a 3” wide object (such as a 3” putty knife) can be used to probe the rubber spring in the affected area. (If the probe penetrates the crack or separation .75” or more, the spring should be replaced). Rubber Springs should be inspected when supporting the trailer.

REPLACEMENT OF A RUBBER SPRING ASSEMBLY

1. Raise the unit until the tires are approximately 4” off the ground, the frame is supported with safety stands and the suspension is hanging unsupported.
2. Remove both tires on the side of the unit the Rubber Springs are to be replaced.
3. Loosen or cut loose brake wires to obtain slack.
4. Remove 3/8” bolts securing Rubber Springs to Hanger Assembly and Beam Assembly.
5. Pry rubber springs out from between the Beam Assembly and the Hanger Assembly.
6. Align and bolt the rubber spring assembly to the Hanger Assembly. Drift pins can be used to align the bolt holes on the Beam Assembly with the Rubber Spring bolt holes (a bottle or floor jack may be needed to raise the Beam Assembly and the bolt holes of the Rubber Spring).
7. Reinstall the shocks.
8. Use heat-shrink connectors to reconnect brake wires. Use tie straps to secure brake wires out of harms way of Beam Assembly, Rubber Springs and Shock Absorbers.
9. Reinstall tires, torque all bolts and remove jack stand

REPLACEMENT OF SHOCK ABSORBER

There are two (2) shock absorbers utilized on the MORryde Independent Rubber Suspension System, per axle. These shock absorbers are made by Monroe. They have special valving and stroke length specifically designed for the MORryde suspension. They are rarely available through Monroe after market dealers. Consult with MORryde directly for replacements. Refer to figure below.

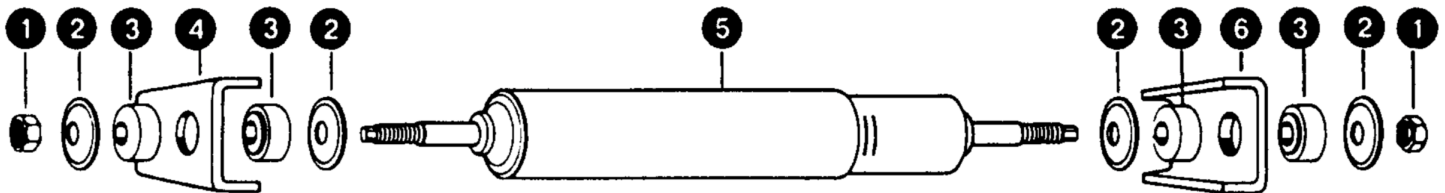

- | | |
|-------------------|---------------------------------|
| 1. Fastener Nut | 4. Clip welded to trailer frame |
| 2. Washer | 5. Shock Absorber |
| 3. Rubber Bushing | 6. Clip welded to Beam Assembly |

To replace a shock absorber:

1. Remove fasteners.
2. Remove shock absorber.
3. Install new bushings on new shock absorber per exploded illustration above.
4. Install new shock absorber.
5. Torque fasteners per Torque Chart in Specification section.

REPLACEMENT OF BEAM ASSEMBLY

The Beam Assembly attaches the wheel and rubber suspension to the Hanger Assembly, which is welded to the frame of the coach. Should a beam and or spindle become damaged and need to be replaced follow the steps below.

1. Jack up the unit (see procedure for jacking up unit).
2. Remove tires.
3. Remove wheel drum and backing plate, which contains the brakes.
4. Remove Rubber Shear Springs from the Beam Assembly.
5. Remove shock at the lower end.
6. Remove nuts and washer at the end of the journal bar (toward inside of frame).
7. Pull out the Beam Assembly.
8. Slide in new Beam Assembly. Bearings should be replaced if damaged or worn.
9. Reinstall nuts in the journal bar, then the shock, spring, backing plate and wheel drum.
10. Appropriately torque all nuts and bolts (see torque chart)
11. Reinstall the tires and wheels.

SUSPENSION ALIGNMENT

The MORryde independent suspension system allows for automotive style toe and camber wheel alignment. This allows you to manage your RV's tire wear as effectively as you manage your tow vehicle. There are four bolts per wheel, which allow for these adjustments. Always adjust the CAMBER first, followed by the TOE.

ADJUSTING THE CAMBER

1. Connect the alignment machine and level the unit on the alignment turntables.
2. If camber is negative, add a shim to the outside of the Torque Bracket.
3. If camber is positive, add a shim to the inside of the Torque Bracket.
4. Shims are available in three sizes - 1/4", 1/8", and 1/16".25"
5. A 14" shim will change the camber approximately 1 degree.
6. To decrease camber, loosen the four Torque Bracket bolts and remove the 34" bolts one at a time to install shims.
7. Unit will need to be raised to add camber.
8. Appropriately torque all bolts.

ADJUSTING THE TOE

1. Connect the alignment machine and level the unit on the alignment turn tables.
2. Loosen the four bolts holding the Torque Bracket to the Hanger Assembly.
3. Move the Torque Bracket Assembly to obtain the correct toe readings on the alignment machine.
4. Tighten the Torque Bracket bolts.
5. Raising the coach is not required to adjust the toe.
6. Toe adjustment can be accomplished with a "port-a-power" or large alignment bar.
7. Appropriately torque all bolts.

TROUBLE SHOOTING

The following list covers the most frequent cause for concern, which may arise with the MORryde Independent Suspension System. If a problem occurs that is not addressed here, please contact MORryde International direct for further service information at 574- 293-1581.

Problem / Symptom	Cause	Correction
<ul style="list-style-type: none"> Excessive tire wear Shock absorbers are worn 	<ul style="list-style-type: none"> Tires not aligned Worn torque bracket bearing Worn shock absorbers Improper tire pressure 	<ul style="list-style-type: none"> Have tires re-aligned Have the bearings replaced Replace shock absorber Adjust air pressure
<ul style="list-style-type: none"> Rough ride 	<ul style="list-style-type: none"> Improper rubber spring deflection Worn shock absorbers Tires rubber on wheel well or the suspension bottoming out 	<ul style="list-style-type: none"> Call MORryde for different density of rubber spring Replace shock absorber If spring deflection is correct and height adjustment is not sufficient, a spacer tube needs to be welded between the frame and the "IS" system.
<ul style="list-style-type: none"> Excessive sway 	<ul style="list-style-type: none"> Improper tire pressure Torn rubber shear spring Improper hitch weight 	<ul style="list-style-type: none"> Adjust air pressure Replace rubber shear spring Travel trailers should have 10%-12% height weight. Fifth wheel trailers should have 20%-25% height weight.

TORQUE CHART

Bolt Size	Grade 5	Grade 8
1/4-20	7	10
5/16-18	14	20
3/8-16	25	35
7/16-14	40	55
1/2-13	60	90
5/8-11	115	170
5/8-18	125	185
3/4-10	190	280

Torque values must be verified with a torque wrench. A calibrated pneumatic impact wrench is not acceptable substitute.

AXLE BRAKE INFORMATION

The MORryde "IS" can utilize several different sizes of brakes. Systems that are factory installed may have different brake components than those systems that are installed after market. In an aftermarket installation, it is possible to upgrade braking systems to use a larger brake such as 12-1/4" x 2-1/2" or 12-1/4" x 3-3/8" brakes or to disc brakes. If after market customers are not upgrading their braking system at the time of installation, the existing braking system on the trailer or fifth wheel will be used.

For more brake information, consult your owner's manual of your trailer or contact MORryde for a more detailed discussion on brake options.

PLEASE DIRECT ALL CORRESPONDENCE TO:

**MORryde International
1966 Sterling Ave.
Elkhart, IN 46516
Phone: (574) 293-1581
Fax: (574) 294-4936
Email: service@morryde.com
www.morryde.com**



Above. Beyond. Always.