



---

## **Application Note**

UPS Application with 4-Pole Input Switches

### 3-Pole vs 4-Pole input switches

#### *4-pole ATS switch feeding UPS*

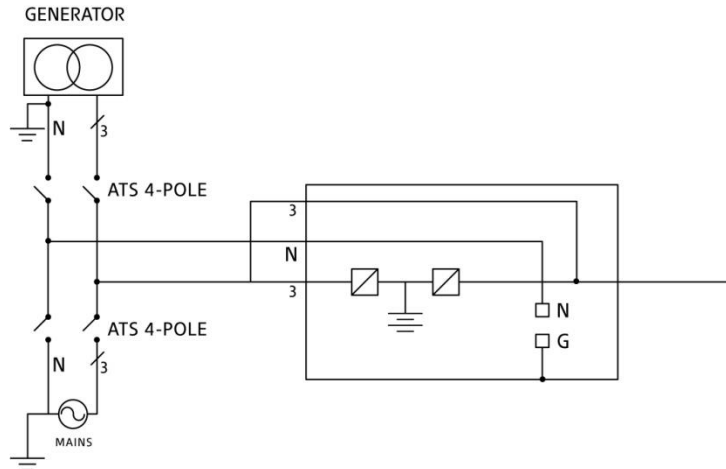

The input power to most large UPS's may come from more than just a single source. In many cases, the UPS will be powered from a generator system when the mains source fails. Or, the UPS system may be optionally fed from either of 2 different mains sources that exist in the same building or facility. In either of these cases, an "Automatic Transfer Switch" (ATS), or a manual transfer switch, is used to transfer the source for the UPS input (and bypass) from the primary source to the secondary or emergency source. In many cases, these transfer switches were 3-pole devices, and during the switchover, the 3 phases were interrupted as the switch changed from one source to another. But the neutral wire simply passed directly through the switch housing, but not through the switch contacts. The neutral was not interrupted by the switch, but this required that the neutrals from separate sources be permanently tied together (solid neutral). This allowed for the potential of circulating currents between the 2 systems that were available to feed the UPS. Since these circulating currents could produce unwanted voltages, and electrical noise, some designers have been recommending 4-pole ATS switches. These switches have a 4<sup>th</sup> pole and contact that is placed between the 2 neutral sources. This allows complete isolation of all phases (and neutral) between the 2 alternate sources, and eliminates circulating currents in the neutral. These ATS's can be wired in several different ways:

- 1) "Overlapping Neutral" (recommended): The 2 source neutrals "overlap" in a make-before-break fashion, whether or not the 3 phase contacts operate in a "break-before-make" sequence. This ensures that the UPS connected downstream of the ATS always has a constant neutral for return currents and for a reference source. Important note for overlapping neutrals: if the 2 neutrals are not grounded at the same point, there may be a voltage difference between the neutrals, allowing current to flow during the time the neutrals overlap. This may cause problems with the generator or alternate source and could result in breakers tripping if the voltage difference is large enough.

Important note for compatibility with critical load: In an unbalanced voltage or unbalanced load condition, the action of changing the neutral reference from source #1 to source #2, can result in sudden voltage changes that may not be acceptable to the connected critical load on the UPS. The only way to ensure that this will not be an issue is to use an isolation transformer with a grounded wye secondary to feed the UPS input.

- 2) Break-before-Make switching: In this case, all 4 poles of the ATS open, including the neutral contact. This “open transition” switching removes the neutral from the input of the UPS briefly. The duration of “open transition” is often adjustable. **We recommend that this open transition time be at least 50 msec. Please note, this type of operation is NOT allowed on the BladeUPS, 93E, 9155, 9315, 93PM 4-wire, or 9355 products.**

Important note for compatibility with critical load: In an unbalanced voltage or unbalanced load condition, the action of changing the neutral reference from source #1 to source #2, can result in sudden voltage changes that may not be acceptable to the connected critical load on the UPS. The only way to ensure that this will not be an issue is to use an isolation transformer with a grounded wye secondary to feed the UPS input.

- 3) Jumpered neutral, or Solid neutral: In this arrangement, a jumper wire is connected in parallel with the neutral contact, essentially converting the ATS to a 3-pole device. The neutrals of the 2 sources are permanently connected together, regardless of the position of the switch. The neutrals should be grounded at the same point to avoid circulating currents.

Why is this information important for UPS applications? With the exception of the 9315 product, all of Eaton’s 3-phase UPSs are transformerless designs. That is, they do not utilize an input or output isolation transformer in their basic configuration. (Isolation transformers are optional if required, but this adds additional space, weight, cost, and inefficiency to the system). So, some transformerless UPSs can generate their own output neutral when on inverter, Like most UPSs, (with or without transformers), the system does not generate a neutral for bypass operation, and requires that the source neutral wire be brought directly through the UPS and passed on to the critical load (if the load requires a neutral). In the BladeUPS, 9155, 9355, 93PM 4-wire or 93E product, if this source neutral is interrupted, for even a short time, ANY phase to neutral loads will be interrupted. **For the above reasons, every UPS quote should request information on whether the UPS will be used with a 4-pole ATS.** The rules below should be followed when quoting UPS systems for this application.

### **Rules for application of Each UPS Product Line when used with a 4-pole input switch**

**BladeUPS, 9155, 9355 93PM 4-wire and 93E Product:** These UPSs should always have an input neutral connected at the bypass input terminals. This neutral must be

continuous and uninterrupted; even if there are no phase-to-neutral loads connected. **NO EXCEPTIONS!** If these UPS products are fed from a 4-pole ATS that interrupts the neutral, a delta-to-wye isolation transformer, with its secondary neutral bonded to ground, must be placed in line with the bypass input of the UPS. This will provide an uninterrupted neutral to the UPS, regardless of the position of the ATS neutral contact. **Note:** if an overlapping neutral or make before break ATS switch is used, the neutrals must overlap for a minimum of 50 msec during the transition. In these cases, a transformer is not needed.

**9390 and 93PM 3-wire Product:** if the 4-pole ATS interrupts the neutral during its transition, see below for the 9390 or 93PM UPS:

1) The ATS transition must be open in both directions. The “break” time must be at least 50 msec. This allows the UPS to operate properly, however *it is important to evaluate whether the critical load will function properly as its neutral reference is rapidly (50 msec) switched.*

2) If there are no phase-to-neutral connected loads, the 9390 UPS output neutral can be bonded to building ground. This should be done **ONLY** if there is no neutral reference kit installed, and there must be no source neutral connected to the UPS input.

**Note:** if an overlapping neutral or make before break ATS switch is used, the neutrals must overlap for a minimum of 50 msec during the transition.

**9395 Product:** if the 4-pole ATS interrupts the neutral during its transition, there are 2 choices for the 9395 UPS:

1) The ATS transition must be open in both directions. The “break” time must be at least 50 msec. This allows the UPS to operate properly, however *it is important to evaluate whether the critical load will function properly as its neutral reference is rapidly (50 msec) switched.*

2) If there are no phase-to-neutral connected loads, the internal reference for 480V system is active and will correctly reference the three phase conductors. This is the method to be used for 480V 9395P products.

**Note:** if an overlapping neutral or make before break ATS switch is used, the neutrals must overlap for a minimum of 50 msec during the transition. In these cases, a transformer is not needed.

## BladeUPS operation with source transfer switches

*Design considerations to ensure proper UPS operation*

With today's requirements for 7 x 24 IT operations, the input power for many UPS systems may come from more than just a single source. In many cases, the UPS system will be powered from a generator system when the mains source fails. Or, the UPS system may be optionally fed from either of two different utility mains sources that exist in the same building or facility. In either of these cases, an automatic transfer switch (ATS), or a manual transfer switch (MTS), is used to transfer the AC source for the UPS input (and bypass) from the primary source to the secondary or emergency source.

### Three-pole and four-pole transfer switches

Traditionally most transfer switches used for switching three-phase power sources were three-pole devices, and during the switchover, the three phases were interrupted as the switch changed from one source to another. But the neutral wire simply passed directly through the switch housing, but not through the switch contacts. The neutral was not interrupted by the switch, but this required that the neutrals from separate sources be permanently tied together. This allowed for the potential of circulating currents between the two systems that fed the UPS system. Since these circulating currents could produce unwanted voltages, and electrical noise, some designers have been recommending four-pole transfer switches. These switches have a 4<sup>th</sup> pole which switches the neutral sources, based on which source is supplying the UPS system. This allows complete isolation of all phases (and neutral) between the two different sources eliminating circulating currents in the neutral and ground conductors.

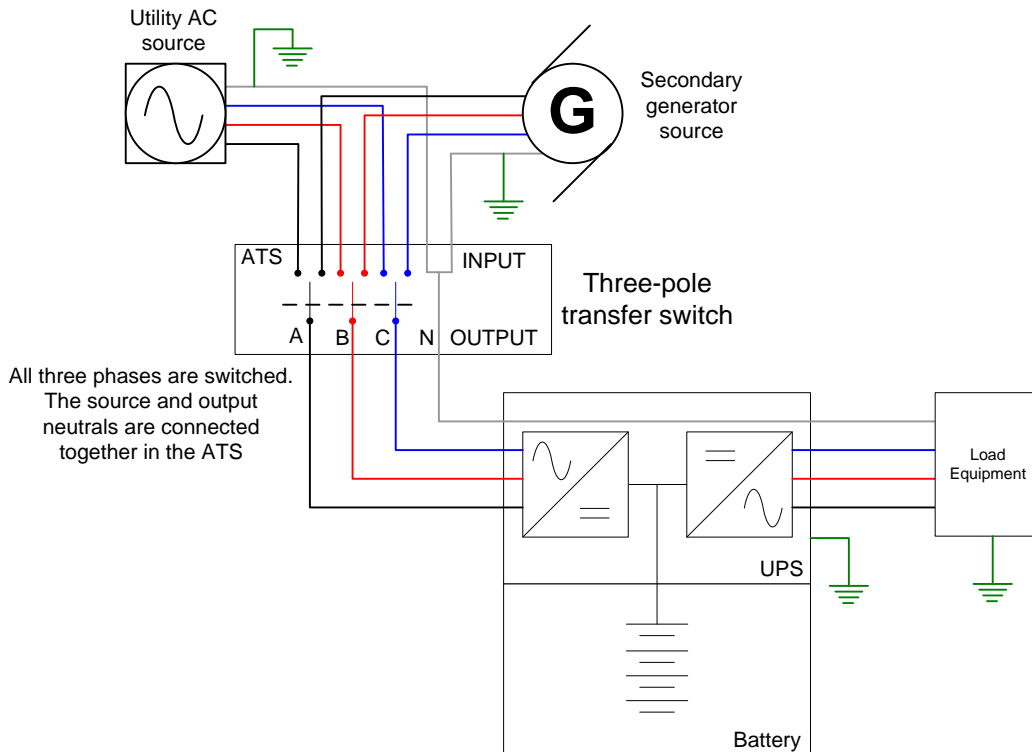

**Figure 1:** Three-pole automatic transfer switch (ATS) feeding UPS system

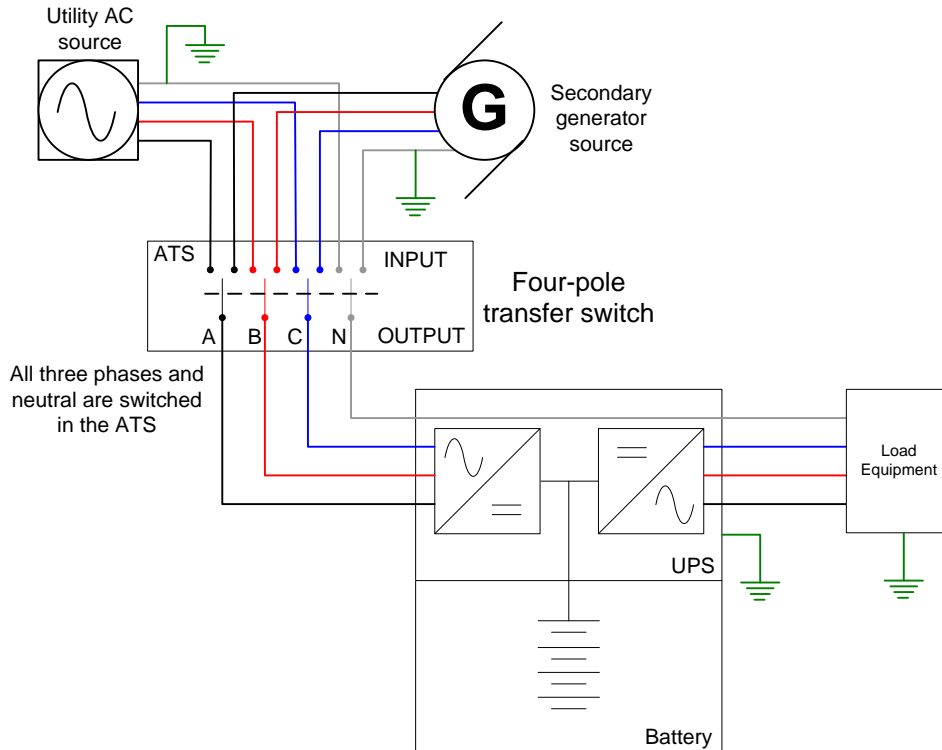

**Figure 2:** Four-pole automatic transfer switch (ATS) feeding UPS system

A four-pole transfer switch can typically be ordered to operate in a couple different ways based on the site needs. In addition the site can wire the switch based on the load equipment requirements. The typical configurations are:

1. **Make-before-break switch:** In this case, all four poles of the ATS close on the second source, before opening the primary source. This is not the common practice because the secondary source can feed power back into the primary source, unless an upstream disconnecting device is also part of the installation. Some transfer switches do have this as an option for synchronized transitions between two like AC sources, and may act this way when coming off of generator operation onto a restored utility source.
2. **Break-before-make switch:** In this case, all four poles of the ATS open, including the neutral contact. This “open transition” switching removes the neutral from the input of the UPS briefly. The duration of “open transition” is often adjustable. We recommend that this open transition time be at least 50 milliseconds (ms).
3. **Overlapping neutral:** The two source neutrals “overlap” in a make-before-break fashion, even though the three-phase contacts operate in a “break-before-make” sequence. This ensures that the UPS connected downstream of the ATS always has a constant neutral for return currents and for a reference source. Important note for overlapping neutrals: if the two neutrals are not grounded at the same point, there may be a voltage difference between the neutrals, allowing current to flow during the time the neutrals overlap. This may cause problems with the generator.
4. **Hard connected neutral:** In this arrangement, a jumper wire is connected in parallel with the neutral contact, essentially converting the ATS to a three-pole device. The neutrals of the two sources are permanently connected together, regardless of the position of the switch. The neutrals should be grounded at the same point to avoid circulating currents.

### Why is this important when deploying a transformerless UPS system?

Why is this information important for UPS applications? With the exception of the 9315 product, all of Eaton's three-phase UPSs are transformerless designs. That is, these systems do not utilize an input or output isolation transformer in their basic configuration, (isolation transformers are optional if required, but this adds additional space, weight, cost, and inefficiency to the system).

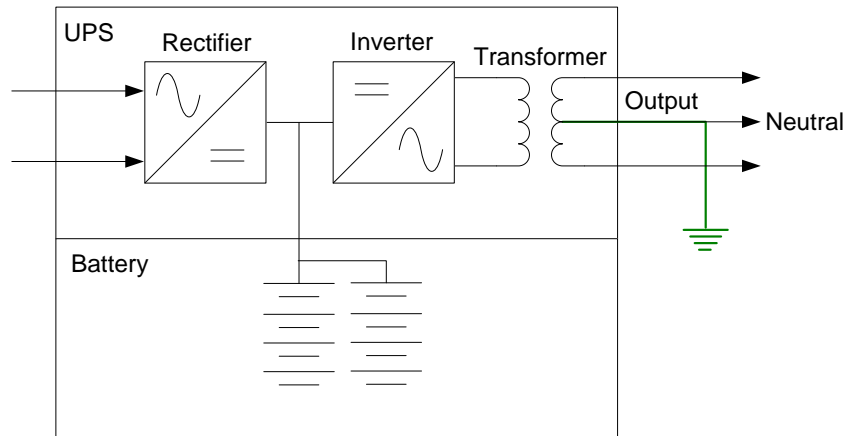

**Figure 3:** UPS design with internal isolation transformer

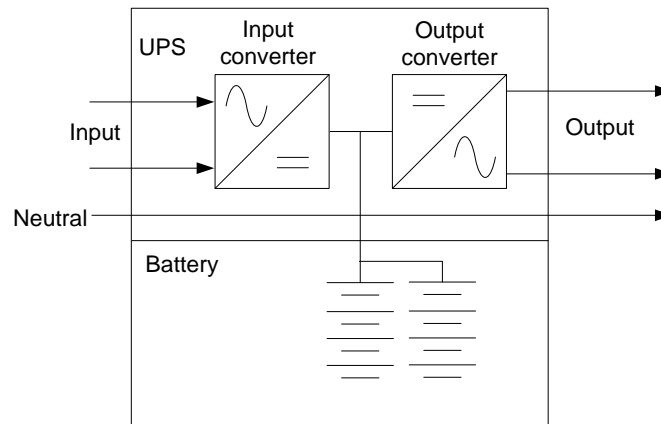

**Figure 4:** Latest generation transformerless UPS design requires no transformer

With no galvanic isolation in the UPS electronics power train, the system does not qualify to be considered a “separately derived” power source. Since it is not a new source it can not break the neutral, and form a new neutral with a new neutral to ground bonding point. This requires that the source neutral conductor be brought directly through the UPS and passed on to the critical load. In addition, to ensure proper operation in bypass mode, the neutral must be supplied from the upstream AC source. In the BladeUPS product, if this source neutral is interrupted for even a short time, ANY phase to neutral loads will be interrupted, even if the UPS is operating on battery. In addition, the UPS firmware will consider this condition as a site fault and immediately shut down the BladeUPS system to ensure safety for anyone working on load equipment on the UPS output.

## **What is this important to ask the customer before selling a BladeUPS?**

For the above reasons, every UPS quote should request information on whether the UPS will be used with a 4-pole ATS. The following questions can help you ensure you have the information you need.

- 1.) Will the UPS have multiple AC input sources?
- 2.) If this is a generator or second utility source, will it include an automatic or manual transfer switch?
- 3.) Will the ATS (MTS) switch the neutral conductor? (four pole)
- 4.) If yes, will the neutral contacts overlap, or will there be a break during the switch between AC sources?

*The guidelines below should be followed when quoting BladeUPS systems for dual source applications.*

### **Input transfer switch guidelines**

The BladeUPS should always have an input neutral connected at the UPS paralleling wireway input terminals, or UPS input cord. This neutral must be continuous and uninterrupted; even if there are no phase-to-neutral loads connected. **NO EXCEPTIONS!** If the BladeUPS is fed from a four-pole ATS that interrupts the neutral, a delta-to-wye isolation transformer, with its secondary neutral bonded to ground, must be placed in line with the input of the UPS. This will provide an uninterrupted neutral to the UPS, regardless of the position of the ATS neutral contact.

Note: if an overlapping neutral or make before break ATS switch is used, the neutrals must overlap for a minimum of 50 ms during the transition. In these cases, a transformer is not needed.