

AcuityBrands®

Tenant Improvement Quickship Solutions

ASHRAE 90.1 code compliant and ready to ship



Keeping and attracting new tenants requires maintenance.

Are you sure that all of your lighting and controls will work together and meet local codes? Acuity Brands can help you make sure your lighting solutions are **up to code** and on top of that, **can ship quickly**.



We deliver A+ certified code-compliant solutions that simply work.

You can select, install and enjoy efficient lighting systems – quickly and confidently. **Why take a risk, when you don't have to?**



A+ Certified solutions from Acuity Brands help you quickly and confidently select and implement lighting systems that are both compatible and consistent. For lighting professionals, it means ease, freedom and confidence that all parts of a certified lighting system will operate together. For more information on A+ certification, go to www.acuitybrands.com/solutions/a-certified

ASHRAE 90.1 Code-Compliant Controls

Easy to understand. Easy to install. Easy to use.

Acuity Controls nLight® networked lighting control solutions aid in ensuring buildings meet the IECC requirements.

- Manual dimming
- Lumen maintenance
- Demand response lighting control
- Automatic daylighting controls
- Occupancy sensing controls
- Plug load controls

eldoLED™ constant-current driver options offer a choice of dimming range for ultra-smooth dimming resolution from 100% to less than 1% , while assuring flicker-free, low current inrush, 89% efficiency, and low EMI.

About ASHRAE 90.1

ASHRAE 90.1 is an energy code designed to reduce energy consumption. The ASHRAE 90.1 2010 energy code has specific requirements for lighting controls. The use of advanced lighting controls to synchronize light levels with daylight, occupancy and multi-level control capability are required in order to be compliant.

About Acuity Controls nLight®

nLight is a networked digital lighting control system that is easy-to-use, easy-to-install and saves energy. Using only standard CAT5e cable, nLight networks occupancy sensors, wall stations and digital LED luminaires to create a digital lighting system with unmatched flexibility! nLight easily scales from one room to an entire campus. Create a lighting control solution that's tailored to your space and needs.



Code Requirements for Common Building Spaces

Control Requirement*	Code Provision	Space Type							
		Private Office	Open Office	Conference, Meeting, Multipurpose Room	Classroom, Lecture Hall, Training Room	Lobby	Corridor	Restroom	Stairwell
On-Off Control	Manual-On or Partial-On	✓	✓	✓	✓				
	Full Automatic-On					✓	✓	✓	✓
	Programmable Timeclock		✓			✓	✓		
	Automatic Full-Off via Occupancy Sensor	✓	✓	✓	✓	✓	✓	✓	✓
Light Level Control	Automatic Partial-Off via Occupancy Sensor								✓
	Space (i.e. Local Switch) Control	✓	✓	✓	✓	✓	✓	✓	✓
Additional Controls	Multi-Level / Dimming Control	✓	✓	✓	✓				
	Multi-Level Daylight Control	✓	✓	✓	✓	✓	✓	✓	✓
	Automatic Receptacle (i.e. Plug Load) Control	✓	✓		✓**				

*Note: This summary is for general information purposes only and is provided without any warranty as to accuracy, completeness, or otherwise. The user should read the applicable code sections for more complete and detailed descriptions of code requirements and exceptions and should consult with a professional engineering or other competent advisor before making any decision or taking any action based on this summary.

**Requirement is for computer classrooms only.



You need solutions FAST. We are LightQuick®.

Project schedules are demanding. You need a partner you can trust. Count on Acuity Brands to deliver the product you need – when, where and how you need it. LightQuick includes:

Local Stock

Over **7,000** products in-stock and available to ship **same-day***.

Local Made-to-Order

Over **100,000** configurable products ship in **2 days or less*^**. To find out which products can be configured at your local Regional Manufacturing and Distribution Center (RMDC), visit www.acuitybrands.com/lightquick.

Local Manufacturing and Logistic Solutions

In-house fabrication, paint capabilities, plus much more.

Local Support

On-site customer care team to support your unique needs.

LightQuick may include select products from the following brands:



You have to be flexible to meet job site needs. Shipping should be flexible too.

Acuity Brands offers logistics capabilities to meet your specific needs.



Special Carton Markings to assist with job site logistics and coordination.



Custom Pallet Sizes to meet your unique job site requirements.



Local Delivery Trucks to bring you products when you need them 24/7.

Tailored manufacturing capabilities are also available

Custom Fabrication to meet your specific needs.

Infinite Powder Paint Options to transform your product's finish.

Custom Length Poles & Drill Patterns reduce normal lead time from 6 – 8 weeks to 2 days!

Not all services available at all RMDCs. Please contact your local RMDC for details.

Need a customized product or solution?

Contact your local customer care team to develop a strategy for your business opportunity as well as support you throughout the ordering and fulfillment process.

Code Compliant A+ Solutions to Ship within 2 Days



Conference Room

Luminaire:

Gotham® EVO LED Downlight
 Mark Architectural Lighting™ Slot 4 or 6 LED

Controls:

nLight

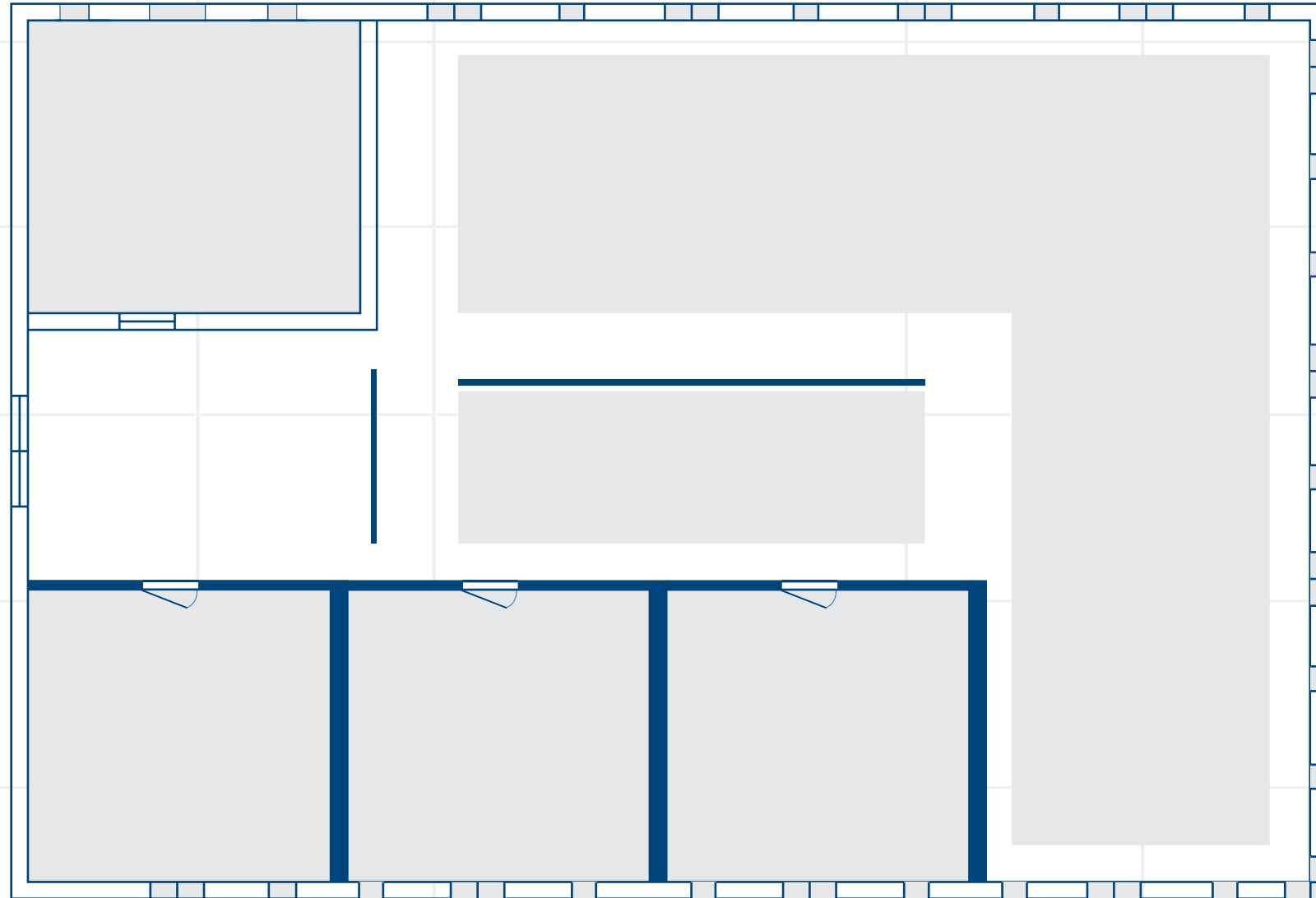

Open Office

Luminaire:

Lithonia Lighting® VT Series LED Troffer

Controls:

nLight

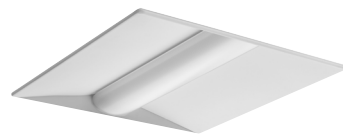

Corridor

Luminaire:

Lithonia Lighting® BLT Series LED

Controls:

nLight



Private Office

Luminaire:

Lithonia Lighting® Avante® LED Direct/Indirect

Controls:

nLight

Private Office: Windows, nLight Enabled Fixtures

Complies with:

- Local Switch (Section 9.4.1.2)
- Multi-Level / Dimming Control (Section 9.4.1.2a)
- Automatic Full-Off via Occupancy Sensor (Section 9.4.1.2b)
- Multi-Level Daylight Control (Section 9.4.1.4/5)
- Plug-Load Control (Section 8.4.2)

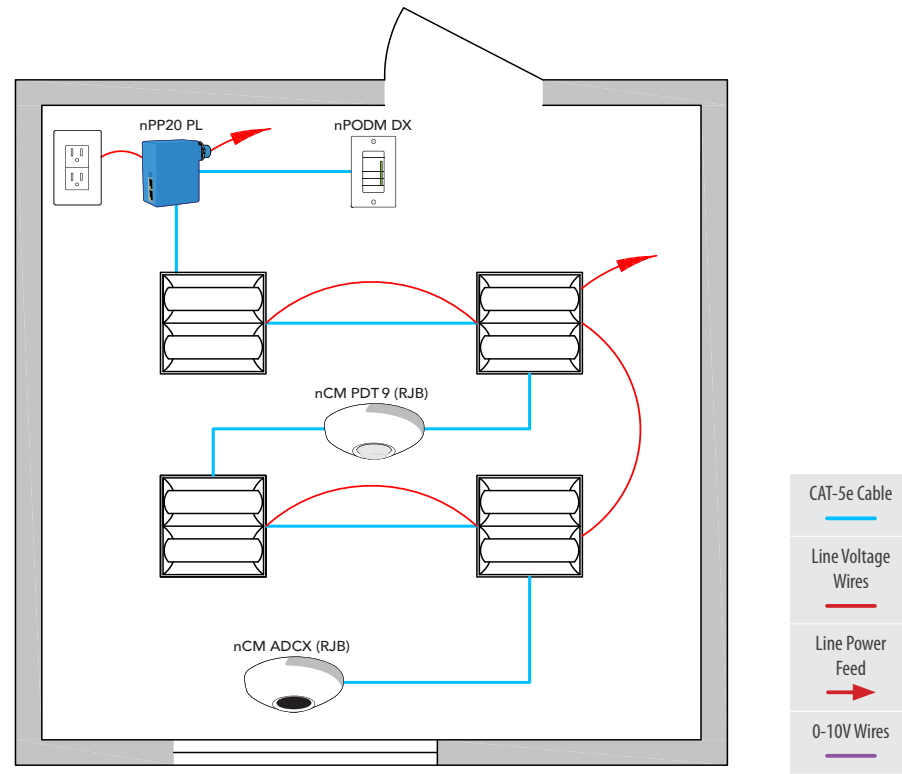

Bill of Materials

Symbol	Qty	Product #	Description
	2	Various Options	nLight Enabled Fixture
	1	nPP20 PL	Plug Load Relay Pack
	1	nPODM DX	On/Off & Raise/Lower WallPod
	1	nCM PDT 9 ADCX (RJB)	Dual Technology Occupancy Sensor

Options

	1	nCM ADCX (RJB)	Automatic Dimming Photocell — If area from sidelighting is >250 ft. ²
--	---	----------------	--

Open Office with nLight Enabled Fixtures

Complies with:

- Local Switch (Section 9.4.1.2)
- Multi-Level / Dimming Control (Section 9.4.1.2a)
- Automatic Full-Off via Occupancy Sensor (Section 9.4.1.2b)
- Multi-Level Daylight Control (Section 9.4.1.4/5)
- Plug-Load Control (Section 8.4.2)

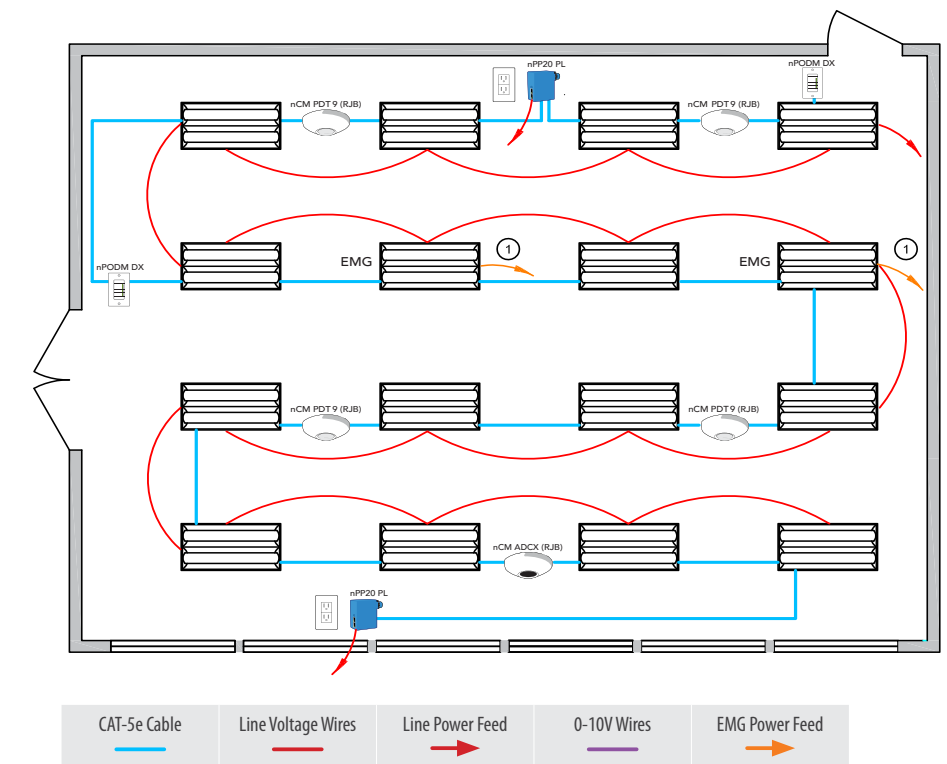

① Not all emergency nLight enabled fixtures require a normal monitoring feed. Refer to the datasheet for additional information.

Bill of Materials

Symbol	Qty	Product #	Description
	14	Various Options	nLight Enabled Fixture
	2	Various Options	nLight Enabled Fixture with EMG option
	2	nPP20 PL	Plug Load Relay Pack
	2	nPODM DX	On/Off & Raise/Lower WallPod
	4	nCM PDT 9 (RJB)	Dual Technology Occupancy Sensor
	1	nCM ADCX (RJB)	Automatic Dimming Control Photocell

Conference Room with nLight Enabled Fixtures

Complies with:

- Local Switch (Section 9.4.1.2)
- Multi-Level / Dimming Control (Section 9.4.1.2a)
- Automatic Full-Off via Occupancy Sensor (Section 9.4.1.2b)
- Multi-Level Daylight Control (Section 9.4.1.4/5)

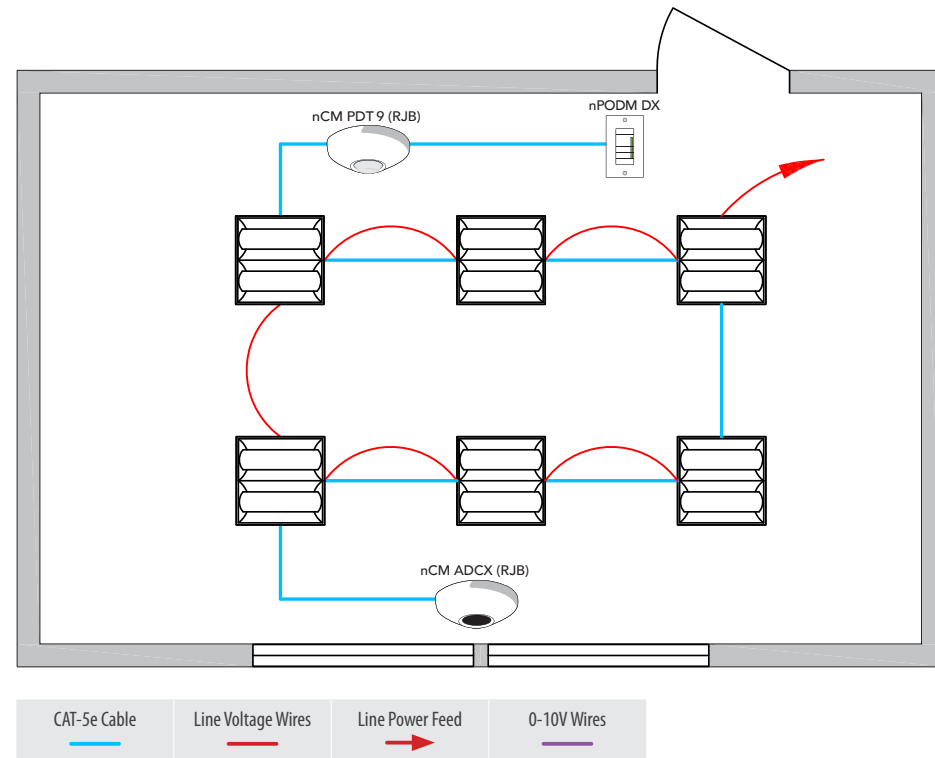

Bill of Materials

Symbol	Qty	Product #	Description
	6	Various Options	nLight Enabled Fixture
	1	nPODM 2P DX	Dual On/Off & Raise/Lower WallPod
	1	nCM PDT 9 (RJB)	Dual Technology Occupancy Sensor

Options

	1	nCM ADCX (RJB)	Automatic Dimming Control Photocell
--	---	----------------	-------------------------------------

Corridor with nLight Enabled Fixtures

Complies with:

- Local Switch (Section 9.4.1.2)
- Automatic Full-Off via Occupancy Sensor (Section 9.4.1.2b)

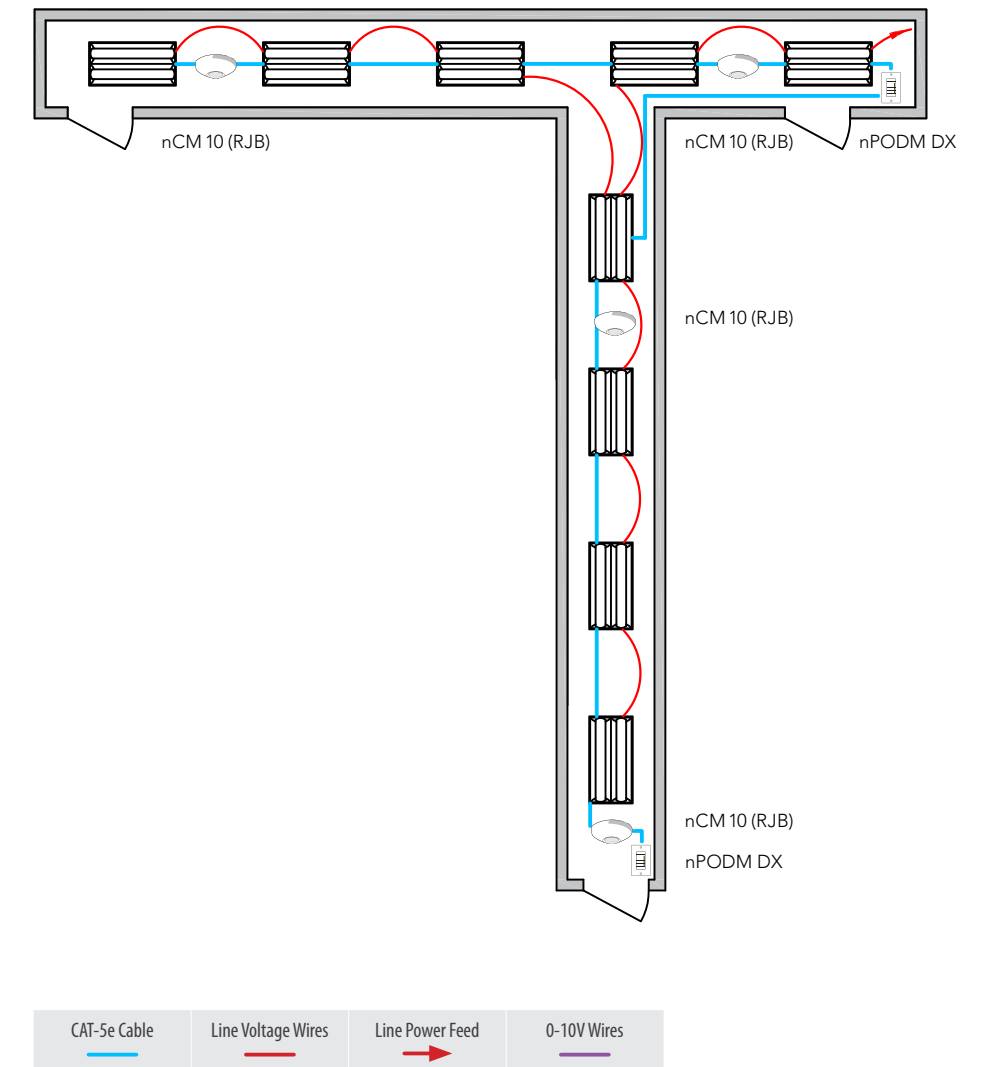

Bill of Materials

Symbol	Qty	Product #	Description
	9	Various Options	nLight Enabled Fixture
	4	nCM 10 (RJB)	PIR Extended Range Occupancy Sensor
	2	nPODM DX	On/Off & Raise/Lower WallPod

When you need it now, Acuity Brands gives you choices.

With more than one million products available to ship in 10 days or less, we can meet your quick ship needs in virtually every category of lighting and controls products. To find out more about our Quick Ship programs, visit www.acuitybrands.com/quickship

Just a few of the 10 Days or Less Quickship Products



Mark Architectural Lighting™
Whisper LED

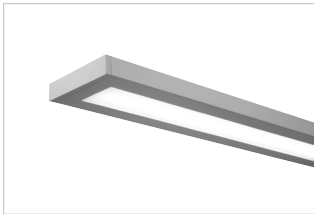

Peerless® Bruno

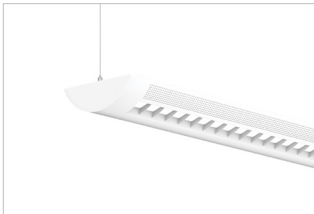

Peerless Cerra 7



Enhance your Acuity Brands experience with these additional tools and services.

Visual® Lighting Software

Perform lighting calculations, complete light level renderings and analyze lifecycle lighting costs with our Visual Lighting software. Visual combines lighting and energy calculation tools with a powerful 3-D modeling tool to deliver accurate space and economic analyses.

www.visual-3d.com

Trial Installation Program (T.I.P.)

T.I.P. allows you to install fixtures onsite to ensure they meet your needs. Whether you would like to test energy savings or performance, or even view the luminaire in the space for aesthetic reasons, take advantage of this program today! Contact your Acuity Brands representative for details.

[Visit AcuityBrands.com](http://AcuityBrands.com)



Expanding the boundaries of lighting™

One Lithonia Way, Conyers, Georgia 30012 | Phone: 800.315.4963

©2015 Acuity Brands Lighting, Inc. All rights reserved. | 11/15 | AB_2512

