

Contents

Motorcycle Safety P. 2

Operation Guide P. 16

Maintenance P. 47

Troubleshooting P. 100

Information P. 121

Specifications P. 143

Index P. 147

Welcome

Congratulations on your purchase of a new Honda motorcycle. Your selection of a Honda makes you part of a worldwide family of satisfied customers who appreciate Honda's reputation for building quality into every product.

To ensure your safety and riding pleasure:

- Read this owner's manual carefully.
- Follow all recommendations and procedures contained in this manual.
- Pay close attention to safety messages contained in this manual and on the motorcycle.

To protect your investment, we urge you to take responsibility for keeping your motorcycle well serviced and maintained. Also, observe the break-in guidelines, and always perform the pre-ride inspection and other periodic checks in this manual.

When service is required, remember that your Honda dealer knows your motorcycle best. If you have the required mechanical "know-how" and tools, you can purchase an official Honda Service Manual to help you perform many maintenance and repair tasks.

➤ P. 137

Read the warranty information thoroughly so that you understand the warranty coverage and that you are aware of your rights and responsibilities. ➤ P. 139

You may also want to visit our website at www.powersports.honda.com.

Canada www.honda.ca

Happy riding!

California Proposition 65 Warning

WARNING: This product contains or emits chemicals known to the State of California to cause cancer and birth defects or other reproductive harm.

A Few Words About Safety

Your safety, and the safety of others, is very important. Operating this motorcycle safely is an important responsibility.

To help you make informed decisions about safety, we have provided operating procedures and other information on safety labels and in this manual. This information alerts you to potential hazards that could hurt you or others.

Of course, it is not practical or possible to warn you about all hazards associated with operating or maintaining a motorcycle. You must use your own good judgment.

You will find important safety information in a variety of forms, including:

- Safety labels on the motorcycle.
- Safety Messages preceded by a safety alert symbol and one of three signal words: DANGER, WARNING, or CAUTION.

These signal words mean:

DANGER

You **WILL** be **KILLED** or **SERIOUSLY HURT** if you don't follow instructions.

WARNING

You **CAN** be **KILLED** or **SERIOUSLY HURT** if you don't follow instructions.

CAUTION

You **CAN** be **HURT** if you don't follow instructions.

Other important information is provided under the following titles:

NOTICE Information to help you avoid damage to your motorcycle, other property, or the environment.

Motorcycle Safety

This section contains important information for safe riding of your motorcycle.
Please read this section carefully.

Safety Guidelines	P. 3
Safety Labels	P. 7
Safety Precautions	P. 9
Riding Precautions	P. 10
Accessories & Modifications	P. 14
Loading	P. 15

Safety Guidelines

Follow these guidelines to enhance your safety:

- Perform all routine and regular inspections specified in this manual.
- Stop the engine and keep sparks and flame away before filling the fuel tank.
- Do not run the engine in enclosed or partly enclosed areas. Carbon monoxide in exhaust gases is toxic and can kill you.

Always Wear a Helmet

It's a proven fact: helmets and protective apparel significantly reduce the number and severity of head and other injuries. So always wear an approved motorcycle helmet and protective apparel. ➤ P. 9

Before Riding

Make sure that you are physically fit, mentally focused and free of alcohol and drugs. Check that you and your passenger are both wearing an approved motorcycle helmet and protective apparel. Instruct your passenger on holding onto the grab rails or your waist, leaning with you in turns, and keeping their feet on the footpegs, even when the motorcycle is stopped.

Take Time to Learn & Practice

Even if you have ridden other motorcycles, practice riding in a safe area to become familiar with how this motorcycle works and handles, and to become accustomed to the motorcycle's size and weight.

Safety Guidelines

We recommend that all riders take a certified course approved by the Motorcycle Safety Foundation (MSF). New riders should start with the basic course, and even experienced riders will find the advanced course beneficial. For information about the MSF training course nearest you, call the national toll-free number: (800) 446-9227.

USA Other riding tips can be found in the You and Your Motorcycle Riding Tips booklet that came with your motorcycle.

Ride Defensively

Always pay attention to other vehicles around you, and do not assume that other drivers see you. Be prepared to stop quickly or perform an evasive maneuver.

Make Yourself Easy to See

Make yourself more visible, especially at night, by wearing bright reflective clothing, positioning yourself so other drivers can see you, signaling before turning or changing lanes, and using your horn when necessary.

Ride within Your Limits

Never ride beyond your personal abilities or faster than conditions warrant. Fatigue and inattention can impair your ability to use good judgment and ride safely.

Don't Drink and Ride

Alcohol and riding don't mix. Even one alcoholic drink can reduce your ability to respond to changing conditions, and your reaction time gets worse with every additional drink. Don't drink and ride, and don't let your friends drink and ride either.

Keep Your Honda in Safe Condition

It's important to keep your motorcycle properly maintained and in safe riding condition. Inspect your motorcycle before every ride and perform all recommended maintenance. Never exceed load limits (➤ P. 15), and do not modify your motorcycle or install accessories that would make your motorcycle unsafe (➤ P. 14).

If You are Involved in a Crash

Personal safety is your first priority. If you or anyone else has been injured, take time to assess the severity of the injuries and whether it is safe to continue riding. Call for emergency assistance if needed. Also follow applicable laws and regulations if another person or vehicle is involved in the crash.

If you decide to continue riding, first turn the ignition switch off, and evaluate the condition of your motorcycle. Inspect for fluid leaks,

check the tightness of critical nuts and bolts, and check the handlebar, control levers, brakes, and wheels. Ride slowly and cautiously. Your motorcycle may have suffered damage that is not immediately apparent. Have your motorcycle thoroughly checked at a qualified service facility as soon as possible.

Emergency Shut-down Procedure for Motorcycles Equipped with Dual Clutch Transmission

CTX700D only

Unlike standard motorcycles, or its manual transmission sibling, the CTX700D with dual-clutch transmission does not have a clutch lever that would provide you with an additional means to control the engine power being transmitted to the rear wheel. Thus, in the unlikely event that you experience a stuck throttle or other unintended application of power to the rear wheel, you should shut down the engine by use of the engine stop switch (➤ P. 31). By moving this switch to the off position, you will immediately stop the engine but maintain all electrical system functions, including lights and indicators.

Carbon Monoxide Hazard

Exhaust contains poisonous carbon monoxide, a colorless, odorless gas. Breathing carbon monoxide can cause loss of consciousness and may lead to death.

If you run the engine in confined or even partly enclosed area, the air you breathe could contain a dangerous amount of carbon monoxide. Never run your motorcycle inside a garage or other enclosure.

WARNING

Carbon monoxide gas is toxic.
Breathing it can cause
unconsciousness and even kill you.

Avoid any areas or activities that
expose you to carbon monoxide.

Safety Labels

Safety and information labels on your motorcycle provide important safety information and may warn you of potential

hazards that could cause serious injury. Read these labels carefully and don't remove them. If a label comes off or becomes hard to read, contact your dealer for a replacement.

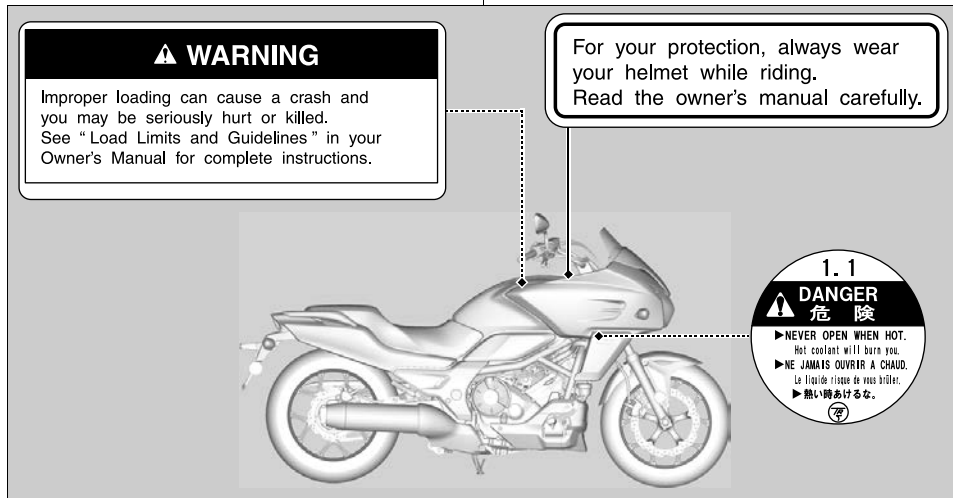

TIRE INFORMATION		
Cold tire pressures :		
(Up to maximum weight capacity)		
Front	250kPa 2.50kgf/cm ²	36psi
Rear	290kPa 2.90kgf/cm ²	42psi
(Up to 90kg(200lbs) load)		
Front	250kPa 2.50kgf/cm ²	36psi
Rear	250kPa 2.50kgf/cm ²	36psi
Maximum weight capacity :176kg(388lbs)		
Tire size : Front 120/70ZR17M/C(58W)		
Rear 160/60ZR17M/C(69W)		
Tire brand	Front	Rear
BRIDGESTONE	BT023F G	BT023R G
METZELER	ROADTEC Z8 INTERACT E ROADTEC Z8 INTERACT	
Min. recommend tire center tread depth.		
Front 1.5mm(0.06in.)		Rear 2.0mm(0.08in.)
Read owner's manual.		
This motorcycle is equipped with tubeless tires.		

CARGO LIMIT
0.5kg / 1.0lbs

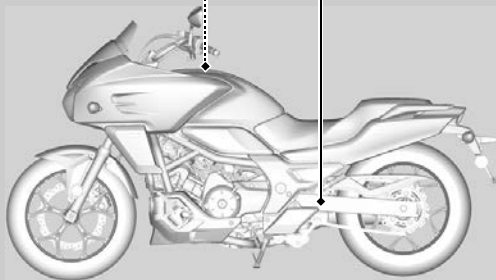

Safety Precautions

- Ride cautiously and keep your hands on the handlebar and feet on the footpegs.
- Keep passenger's hands onto the grab rails or your waist, passenger's feet on the footpegs while riding.
- Always consider the safety of your passenger, as well as other drivers and riders.

Protective Apparel

Make sure that you and any passenger are wearing an approved motorcycle helmet, eye protection, and high-visibility protective clothing. Ride defensively in response to weather and road conditions.

■ Helmet

Should be safety-standard certified, high-visibility, and correct size for your head

- Must fit comfortably but securely, with the chin strap fastened.

- Face shield with unobstructed field of vision or other approved eye protection.

USA Look for a DOT (Department of Transportation) certification label on any helmet you buy.

WARNING

Not wearing a helmet increases the chance of serious injury or death in a crash.

Make sure that you and any passenger always wear an approved helmet and protective apparel.

■ Gloves

Full-finger leather gloves with high abrasion resistance

Riding Precautions

Boots or Riding Shoes

Sturdy boots with non-slip soles and ankle protection

Jacket and Pants

Protective, highly visible, long-sleeved jacket and durable long pants for riding (or a protective suit).

Riding Precautions

Break-in Period

During the first 300 miles (500 km) of running, follow these guidelines to ensure your motorcycle's future reliability and performance.

- Avoid full-throttle starts and rapid acceleration.
- Avoid hard braking and rapid down-shifts.
- Ride conservatively.

Brakes

Observe the following guidelines:

- Avoid excessively hard braking and down-shifts.
 - ▶ Sudden braking can reduce the motorcycle's stability.
 - ▶ Where possible, reduce speed before turning; otherwise you risk sliding out.

- Exercise caution on low traction surfaces.
 - ▶ The tires slip more easily on such surfaces and braking distances are longer.
- Avoid continuous braking.
 - ▶ Repeated braking, such as when descending long, steep slopes can seriously overheat the brakes, reducing their effectiveness. Use engine braking with intermittent use of the brakes to reduce speed.
- For full braking effectiveness, operate both the front and rear brakes together.

Anti-lock Brake System (ABS)

CTX700A/D only

This model is also equipped with an Anti-lock Brake System (ABS) designed to help prevent the brakes from locking up during hard braking.

- ABS does not reduce braking distance. In certain circumstances, ABS may result in a longer stopping distance.
- ABS does not function at speeds below 6 mph (10 km/h).
- The brake lever and pedal may recoil slightly when applying the brakes. This is normal.
- Always use the recommended tires to ensure correct ABS operation.

Riding Precautions

Engine Braking

Engine braking helps slow your motorcycle down when you release the throttle. For further slowing action, downshift to a lower gear. Use engine braking with intermittent use of the brakes to reduce speed when descending long, steep slopes.

Wet or Rainy Conditions

Road surfaces are slippery when wet, and wet brakes further reduce braking efficiency. Exercise extra caution when braking in wet conditions.

If the brakes get wet, apply the brakes while riding at low speed to help them dry.

Parking

- Park on a firm, level paved surface.
- If you must park on a slight incline or loose surface, park so that the motorcycle cannot move or fall over.
- Make sure that high-temperature parts cannot come into contact with flammable materials.
- Do not touch the engine, muffler, brakes and other high-temperature parts until they cool down.
- To reduce the likelihood of theft, always lock the handlebar and remove the key when leaving the motorcycle unattended. Use of an anti-theft device is also recommended.

| Parking with the Side Stand

1. Stop the engine.
2. Push the side stand down.
3. Slowly lean the motorcycle to the left until its weight rests on the side stand.
4. Turn the handlebar fully to the left.
 - ▶ Turning the handlebar to the right reduces stability and may cause the motorcycle to fall.
5. Turn the ignition switch to the LOCK position and remove the key. ➤ P. 29

Refueling and Fuel Guidelines

Follow these guidelines to protect the engine and catalytic converter:

- Use only unleaded gasoline.
- Use recommended octane number. Using lower octane gasoline will result in decreased engine performance.
- Do not use fuels containing a high concentration of alcohol. ➤ P. 136
- Do not use stale or contaminated gasoline or an oil/gasoline mixture.
- Avoid getting dirt or water in the fuel tank.

Accessories & Modifications

We strongly advise that you do not add any accessories that were not specifically designed or approved for your motorcycle by Honda or make modifications to your motorcycle from its original design. Doing so can make it unsafe. Modifying your motorcycle may also void your warranty and make your motorcycle illegal to operate on public roads and highways. Before deciding to install accessories on your motorcycle be certain the modification is safe and legal.

WARNING

Improper accessories or modifications can cause a crash in which you can be seriously hurt or killed.

Follow all instructions in this owner's manual regarding accessories and modifications.

Do not pull a trailer with, or attach a sidecar to, your motorcycle. Your motorcycle was not designed for these attachments, and their use can seriously impair your motorcycle's handling.

Loading

- Carrying extra weight affects your motorcycle's handling, braking and stability. Always ride at a safe speed for the load you are carrying.
- Avoid carrying an excessive load and keep within specified load limits.
 - ☒ **Maximum weight capacity** P. 143
- Tie all luggage securely, evenly balanced and close to the center of the motorcycle.
- Do not place objects near the lights or the muffler.

WARNING

Overloading or improper loading can cause a crash and you can be seriously hurt or killed.

Follow all load limits and other loading guidelines in this manual.

Parts Location

CTX700/A

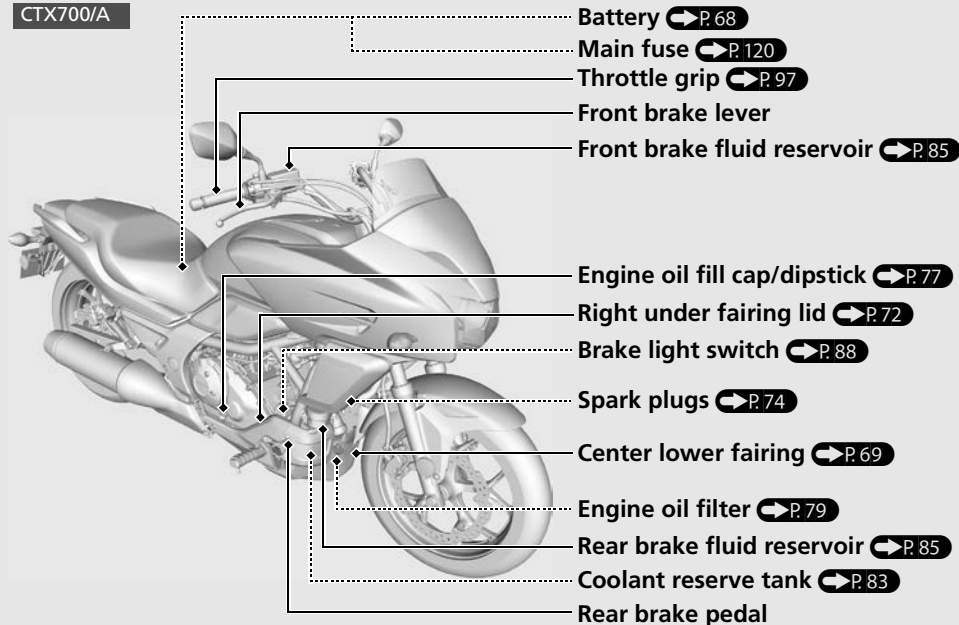

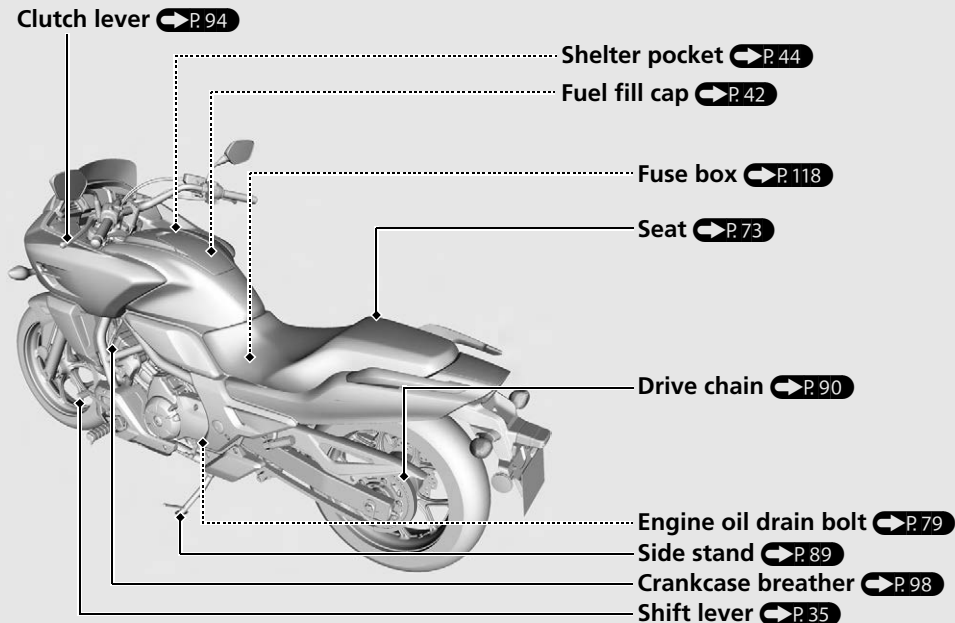

Parts Location *(Continued)*

CTX700D

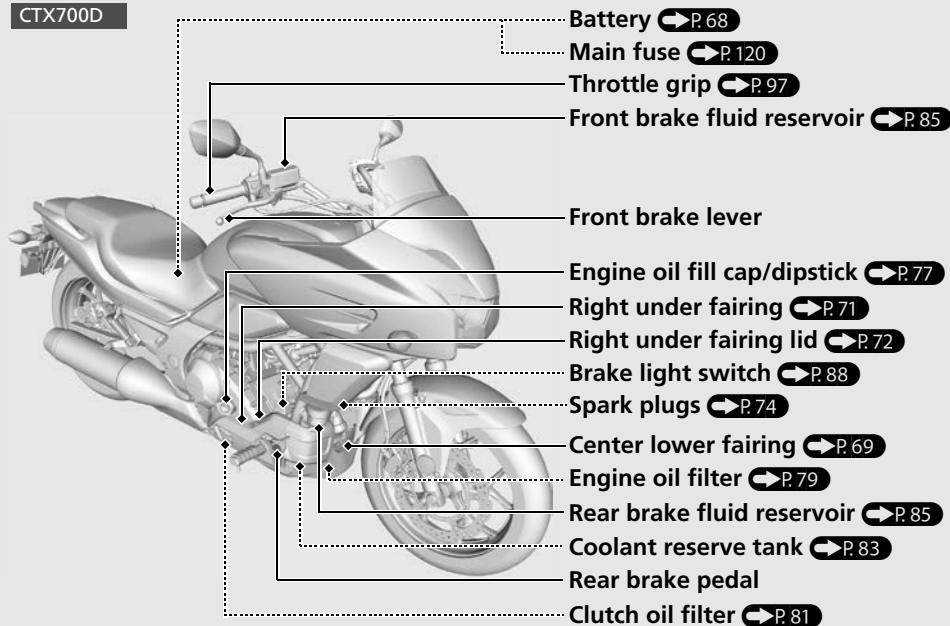

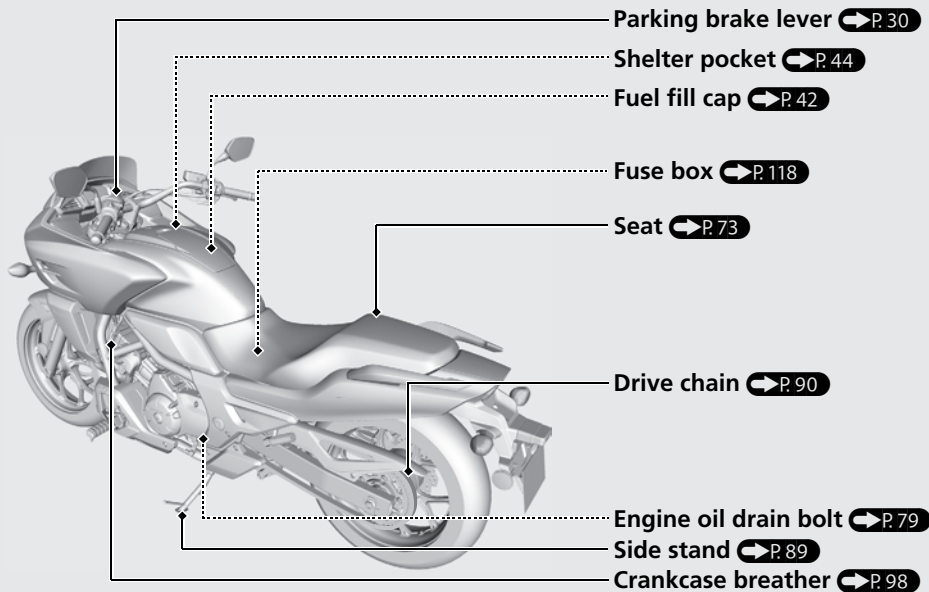

Instruments

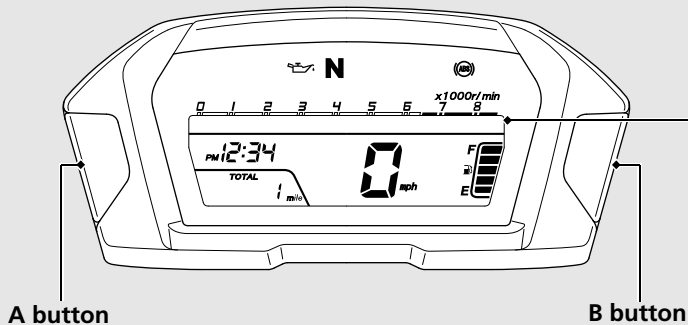

Display Check

When the ignition switch is turned on, all the mode and digital segments will show.

If any part of these displays does not come on when it should, have your dealer check for problems.

CTX700/A

Clock (12-hour display)

To set the clock: P.25

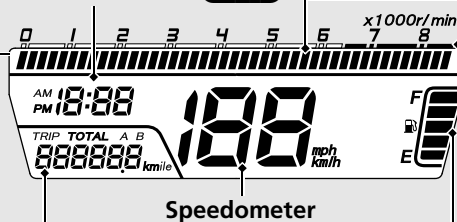
**Tachometer****NOTICE**

Do not operate the engine in the tachometer red zone. Excessive engine speed can adversely affect engine life.

Tachometer red zone
(excessive engine rpm range)

Odometer [TOTAL] & Tripmeter [TRIP A/B]

A button switches between odometer & tripmeters at the ordinary display.

- Odometer: Total distance ridden.
- Tripmeter: Distance ridden since tripmeter was reset (press and hold B button to reset to 0.0 mile/km).

Fuel gauge

Remaining fuel when only 1st (E) segment starts flashing:
approximately
0.98 US gal (3.7 liters)

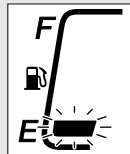

If the fuel gauge indicator repeat flashing or turned off: P.106

Instruments (Continued)

CTX700D

Clock (12-hour display)

To set the clock: P.25

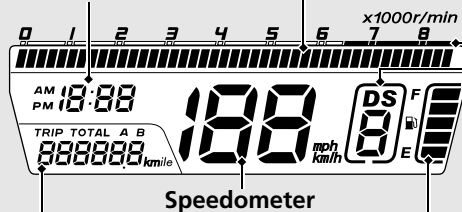

Tachometer

NOTICE

Do not operate the engine in the tachometer red zone. Excessive engine speed can adversely affect engine life.

Tachometer red zone

(excessive engine rpm range)

Odometer [TOTAL] & Tripmeter [TRIP A/B]

A button switches between odometer & tripmeters at the ordinary display.

- Odometer: Total distance ridden.
- Tripmeter: Distance ridden since tripmeter was reset (press and hold B button to reset to 0.0 mile/km).

Fuel gauge

Remaining fuel when only 1st (E) segment starts flashing:
approximately
0.98 US gal (3.7 liters)

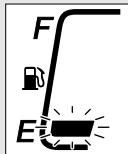

If the fuel gauge indicator repeat flashing or turned off: P.106

D indicator



Comes on when the D mode is selected in the AT MODE.  P.39

S indicator

Comes on when the S mode is selected in the AT MODE.  P.39

Gear position indicator

The gear position is shown in the gear position indicator when the D, S mode or MT MODE are selected.

- ▶ "-" appears for a few seconds and then goes off when the engine starts.
- ▶ "-" flashes when the engine stop switch position is changed from  (Run) to  (Off) position with the ignition switch on.
- ▶ "-" flashes when the ignition switch is turned on with the engine stop switch  (Off) position.

The indicator may flash if:

- ▶ The front wheel leaves the ground.
- ▶ You turn the wheel while the motorcycle is upright on the stand.

This is normal. To operate the system again, turn the ignition switch off, then on again.

If the "-" indicator is blinking in the gear position window while riding:  P.105

Instruments *(Continued)*

Display Setting

You can adjust the three settings.

- Backlight brightness adjustment
- Clock setting
- Changing of speed and mileage unit

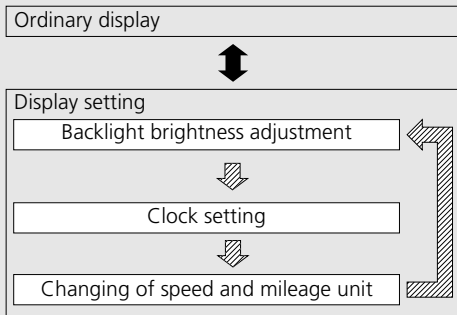

 Press and hold A button and B button

 Press A button

In addition, to return to the ordinary display at display setting.

- The button is not pressed for about 30 seconds
 - Turn the ignition switch off and then on
- Each setting will be cancelled if the A button is not pressed.

1 Backlight brightness adjustment:

You can adjust the brightness to one of three levels.

- 1 Turn the ignition switch to ON.
- 2 Press and hold A button and B button until the minute digit displays the brightness level.
- 3 Press B button. The brightness is switched.

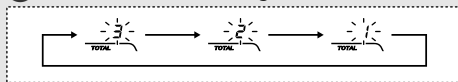

- 4 Press A button. The backlight is set, and then the display moves to the clock setting.

2 Clock setting:

- 1 After backlight brightness adjustment, the hour digits start flashing.
- 2 Press B button until the desired hour and AM/PM are displayed.
 - ▶ Press and hold to advance the hour fast.

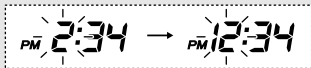

- 3 Press A button. The minute digits start flashing.

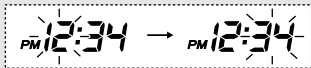

- 4 Press B button until the desired minute is displayed.
 - ▶ Press and hold to advance the minute fast.

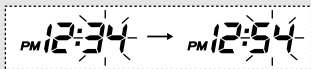

- 5 Press A button. The clock is set, and then the display moves to the changing of the speed and mileage unit.

3 Changing of speed and mileage unit:

- 1 After clock setting, the speed and mileage unit start flashing.
- 2 Press B button to select either "mph" and "mile" or "km/h" and "km".
- 3 Press A button. The speed and mileage unit is set, and then the display returns to the backlight brightness adjustment.

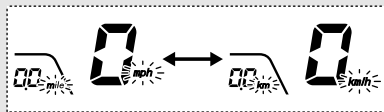

Indicators

If one of these indicators does not come on when it should, have your dealer check for problems.

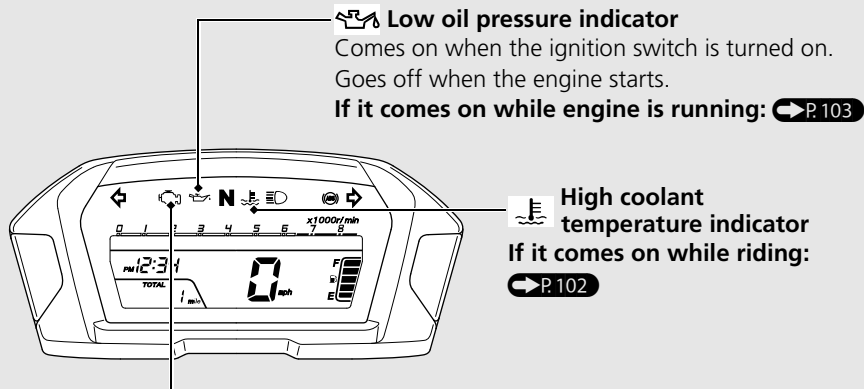

Low oil pressure indicator

Comes on when the ignition switch is turned on.
Goes off when the engine starts.

If it comes on while engine is running: ➔ P.103





High coolant temperature indicator

If it comes on while riding:

➔ P.102



PGM-FI (Programmed Fuel Injection) malfunction indicator lamp (MIL)

Comes on briefly when the ignition switch is turned on with the engine stop switch in the  (Run) position. Comes on when the ignition switch is turned on with the engine stop switch in the  (Off) position.

If it comes on while engine is running: ➔ P.103

(P) Parking brake indicator

CTX700D only

Lights as a reminder that you have not released the parking brake lever.

(ABS)

ABS (Anti-lock Brake System) indicator

CTX700A/D only

Comes on when the ignition switch is turned on. Goes off when your speed reaches approximately 6 mph (10 km/h).

If it comes on while riding: ➡ P. 104

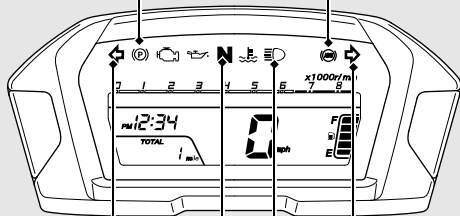

↶ Left turn signal indicator

➡ Right turn signal indicator

☰ High beam indicator

N Neutral indicator

Comes on when the transmission is in Neutral.

Switches

CTX700/A

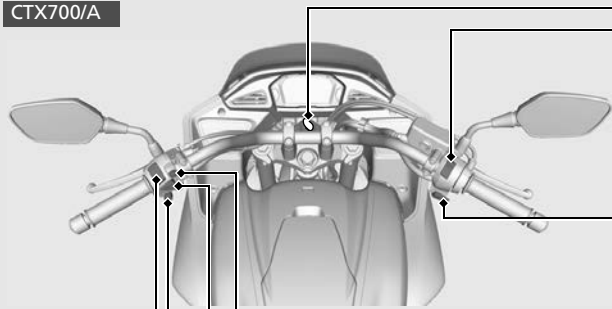

Engine stop switch

Should normally remain in the  (Run) position.

▶ In an emergency, switch to the  (Off) position to stop the engine.

Start button

Hazard switch

Switchable when the ignition switch is on. Can be turned to off regardless of the ignition switch position.



▶ The signals continue flashing when the ignition switch is in the OFF or LOCK position after the hazard switch is on.

Horn button

Turn signal switch

▶ Pressing the switch turns the turn signal off.

Headlight dimmer switch

-  : High beam
-  : Low beam

Ignition switch

Switches the electrical system on/off, locks the steering.

- ▶ Key can be removed when in the OFF or LOCK position.

Steering Lock

Lock the steering when parking to help prevent theft.

A U-shaped wheel lock or similar device is also recommended.

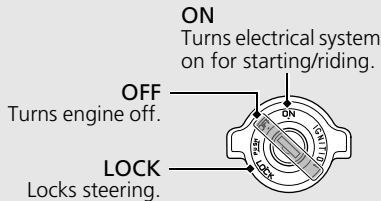
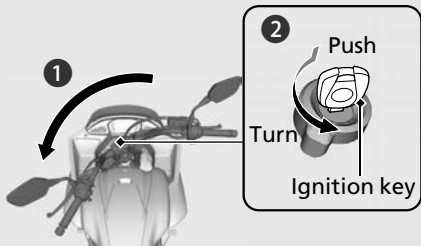

Locking

- 1 Turn the handlebar all the way to the left.
- 2 Push the key down, and turn the ignition switch to the LOCK position.
 - ▶ Jiggle the handlebar if the lock is difficult to engage.
- 3 Remove the key.

Unlocking

Insert the key, push it in, and turn the ignition switch to the OFF position.

Switches *(Continued)*

CTX700D

Parking brake lever and Release button

Be sure the parking brake is applied while parking and warming up the engine.

- ▶ Make sure the parking brake lever is released before riding.

To apply the parking brake lock

Pull the parking brake lever back to lock the rear wheel.

- ▶ Be sure the release button pops out and parking brake lever is not released.
- ▶ The parking brake lock will not function if the parking brake is not adjusted properly.  P. 87

To release the parking brake lock

Release the parking brake lever by lightly pulling in the lever (①) and pressing the release button (②).

- ▶ Before riding, check that the parking brake indicator is turned off and make sure that the parking brake is fully released so there is no drag on the rear wheel.

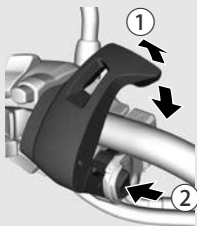



 **Hazard switch**  P. 28

Shift up switch (+)

To shift up the gear.  P. 41

Headlight dimmer switch

-  : High beam
-  : Low beam

 **Turn signal switch**

- ▶ Pressing the switch turns the turn signal off.

Shift down switch (-)

To shift down the gear.

 P. 41

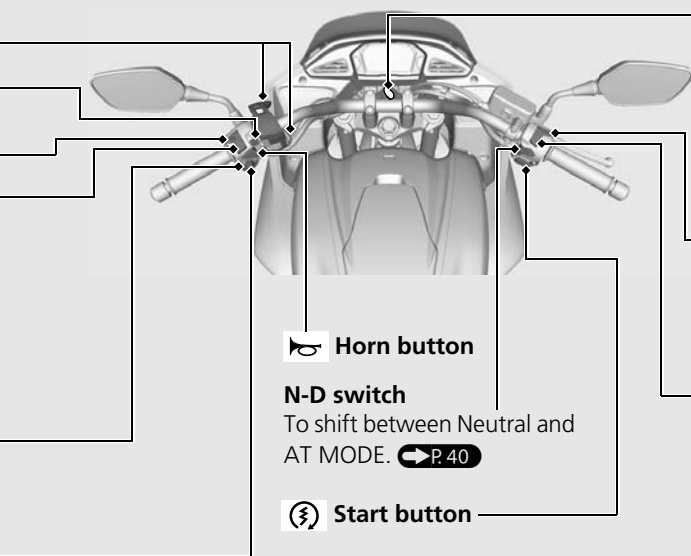
**Ignition Switch**

Switches the electrical system on/off, locks the steering.

- ▶ Key can be removed when in the OFF or LOCK position.

Steering Lock: ➡ P.29

AT/MT switch

To shift between the AT MODE and MT MODE. ➡ P.40

Engine stop switch

Should normally remain in the (Run) position.

- ▶ In an emergency, switch to the (Off) position to stop the engine.

 **Horn button**

N-D switch

To shift between Neutral and AT MODE. ➡ P.40

 **Start button**

Starting the Engine

CTX700/A

Start your engine using the following procedure, regardless of whether the engine is cold or warm.

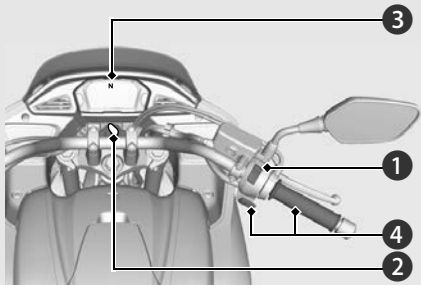

NOTICE

- If the engine does not start within 5 seconds, turn the ignition off and wait 10 seconds before trying to start the engine again to recover battery voltage.
- Extended fast idling and revving the engine can damage the engine, and the exhaust system.
- Snapping the throttle or fast idling for more than about 5 minutes may cause exhaust pipe discoloration.

- ① Make sure the engine stop switch is in the  (Run) position.
- ② Turn the ignition switch to the ON position.
- ③ Shift the transmission to Neutral (**N** indicator comes on). Alternatively, pull in the clutch lever to start your motorcycle with the transmission in gear so long as the side stand is raised.
- ④ Press the start button with the throttle completely closed.

If the engine does not start:

- ① Open the throttle fully and press the start button for 5 seconds.
- ② Repeat the normal starting procedure.
- ③ If the engine starts, open the throttle slightly if idling is unstable.
- ④ If the engine does not start, wait 10 seconds before trying steps ① & ② again.

If Engine Will Not Start  P.101

CTX700D

Start your engine using the following procedure, regardless of whether the engine is cold or warm.

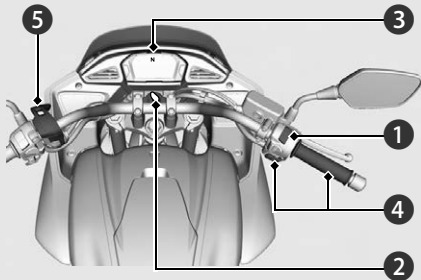

- 1 Make sure the engine stop switch is in the  (Run) position.
- 2 Turn the ignition switch to the ON position.
- 3 Check the transmission is in Neutral (**N** indicator comes on).
- 4 Press the start button with the throttle completely closed.
- 5 Make sure the parking brake lever is released before riding.

If Engine Does Not Start  **P.32**

NOTICE

- If the engine does not start within 5 seconds, turn the ignition off and wait 10 seconds before trying to start the engine again to recover battery voltage.
- Extended fast idling and revving the engine can damage the engine, and the exhaust system.
- Snapping the throttle or fast idling for more than about 5 minutes may cause exhaust pipe discoloration.

Starting the Engine *(Continued)*

When you stop the engine

- ① To stop the engine, put the transmission in Neutral (**N** indicator comes on).
 - ▶ If you turn the ignition switch to the OFF position when the motorcycle is in gear, the engine will shut off with the clutch disengaged.
- ② Turn the ignition switch off.
- ③ Pull the parking brake lever when you park the motorcycle.

Shifting Gears

CTX700/A

Your motorcycle transmission has 6 forward gears in a one-down, five-up shift pattern.

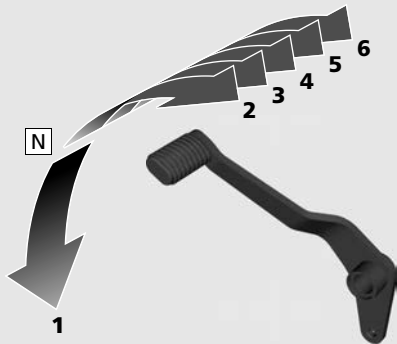

If you put the motorcycle in gear with the side stand down, the engine will shut off.

Recommended Shift Points

Shifting Up

From 1st to 2nd	12 mph (20 km/h)
From 2nd to 3rd	19 mph (30 km/h)
From 3rd to 4th	25 mph (40 km/h)
From 4th to 5th	31 mph (50 km/h)
From 5th to 6th	37 mph (60 km/h)

Shifting Down

From 6th to 5th	28 mph (45 km/h)
From 5th to 4th	22 mph (35 km/h)
From 4th to 3rd	16 mph (25 km/h)

NOTICE

Improper shifting can damage the engine, transmission, and drive train. Also, coasting or towing the motorcycle for long distances with the engine off can damage the transmission.

Shifting Gears *(Continued)*

CTX700D

CTX700D is equipped with an automatically controlled 6-speed transmission. It can be shifted automatically (by AT MODE) or manually (by MT MODE).

Recommended Shift Points

Shifting Up

From 1st to 2nd	12 mph (20 km/h)
From 2nd to 3rd	19 mph (30 km/h)
From 3rd to 4th	25 mph (40 km/h)
From 4th to 5th	31 mph (50 km/h)
From 5th to 6th	37 mph (60 km/h)

Shifting Down

From 6th to 5th	34 mph (55 km/h)
From 5th to 4th	25 mph (41 km/h)
From 4th to 3rd	19 mph (31 km/h)
From 3rd to 2nd	15 mph (24 km/h)
From 2nd to 1st	9 mph (15 km/h)

NOTICE

Improper shifting can damage the engine, transmission, and drive train. Also, coasting or towing the motorcycle for long distances with the engine off can damage the transmission.

CTX700D

Dual Clutch Transmission

In order to respond to rider demands in a broad range of situations, the transmission is equipped with three operating modes, AT MODE (including D mode for regular operation and S mode for sport riding); and MT MODE (MT mode for a 6-speed manual operation), which delivers the same shift feel as a manual transmission.

- ▶ Always use the recommended tires and sprockets to ensure correct Dual Clutch Transmission operation.

The Dual Clutch Transmission system runs a self check immediately after starting the engine. "-" appears in the gear position indicator window for a few seconds, then goes out.

While "-" appears, you cannot shift into gear.

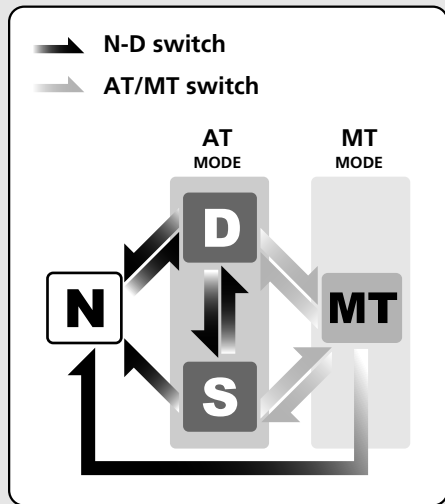

Shifting Gears *(Continued)*

Neutral (N):

Neutral is selected automatically when you turn the ignition switch to ON.

If neutral is not selected when you turn the ignition switch to ON:

- ▶ Turn the ignition off and on again.
- ▶ If neutral is still not selected after turning the ignition off then on again. ➤ P. 105
- ▶ You may hear (click) noises when the transmission shifts to Neutral (N). This is normal.

When you can change between N and D

- ▶ Motorcycle is stopped and the engine is idling.
- ▶ Throttle is completely closed. It is not possible to change from Neutral to D mode while the throttle is applied.
- ▶ You cannot change between N and D mode while the wheels are rotating.
- ▶ Side stand is raised.

NOTICE

- To prevent clutch damage, do not use the throttle to keep the motorcycle stopped uphill.

AT MODE: In this mode the gears are shifted automatically according to your riding conditions.

And also using the shift up switch (+) or shift down switch (-), you can temporarily shift up or down. These switches are convenient when you want to temporarily down-shift in front of a curve, etc.  P. 41

You can choose between two modes within AT MODE: D mode and S mode.

D mode (AT): This is the standard mode when AT MODE is selected. Select D mode for regular operation and efficient fuel economy.

S mode (AT): Select this mode while riding in AT MODE when you need more power, such as when overtaking, climbing hills, or pulling away.

MT MODE: MT MODE (6-speed manual operation) You can choose between 6 gears in this mode.

Shifting Gears *(Continued)*

Changing between Neutral and AT/MT

Changing from Neutral (N) to AT MODE

Press the D/S side of the N-D switch (①). The D mode indicator comes on, "1" is shown in the gear position indicator and first gear is selected.

Changing from AT or MT MODE to Neutral

Press N on the N-D switch (②).

Changing between D mode and S mode while in AT MODE

Press the D/S side of the N-D switch. The S or D mode indicator comes on (③,④).

Changing between AT MODE and MT MODE

Press the AT/MT switch (⑤).

The S or D indicator goes out while MT MODE is selected (⑥).

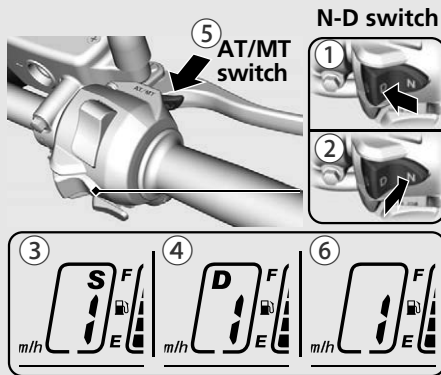

Riding in MT MODE

Shift up and down with the + and - switch. The selected gear is shown on the gear position indicator.

- ▶ If the MT MODE is selected, the transmission does not shift up automatically. Do not allow the engine revs to go into the red zone.
- ▶ The transmission automatically shifts down when you slow down, even in MT MODE.
- ▶ You will start from 1st gear even if MT MODE is selected.

Gear shift operation

Shifting Up:

Press the shift up switch (+) (7).

Shifting Down:

Press the shift down switch (-) (8).

You cannot continue shifting gears by keeping the shift switch pressed.

To continue shifting gears release the switch and press it again.

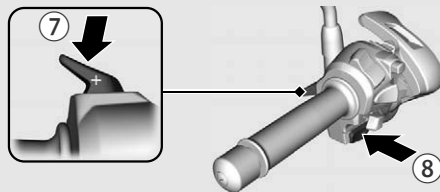

Shift Limit

You cannot downshift if the engine will exceed the rev limit. ➡ P. 36

Refueling

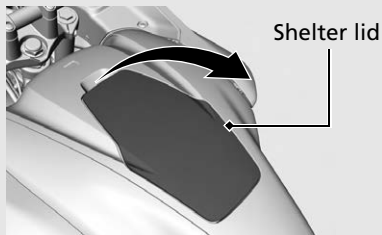

Fuel type: Unleaded gasoline only

Recommended fuel octane number:

Pump Octane Number (PON) 86 or higher.

Tank capacity: 3.28 US gal (12.4 liters)

Refueling and Fuel Guideline ➔ P.13

Opening the Fuel Fill Cap

- 1 Open the shelter lid.
- 2 Insert the ignition key, and turn it clockwise to remove the fuel fill cap.

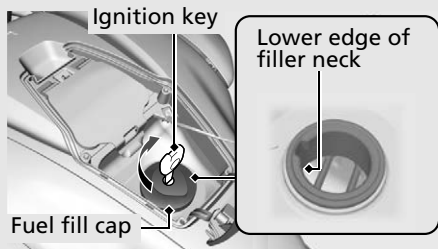

Do not fill with fuel above the lower edge of the filler neck.

Closing the Fuel Fill Cap

- ① After refueling, align the fuel fill cap latch with the slot in the filler neck.
- ② Push the fuel fill cap into the filler neck until it snaps closed and locks.
- ③ Remove the key.
 - ▶ The key cannot be removed if the fuel fill cap is not locked.
- ④ Close the shelter lid.

WARNING

Gasoline is highly flammable and explosive. You can be burned or seriously injured when handling fuel.

- Stop the engine, and keep heat, sparks, and flame away.
- Handle fuel only outdoors.
- Wipe up spills immediately.

Storage Equipment

Shelter Pocket

Pocket lid

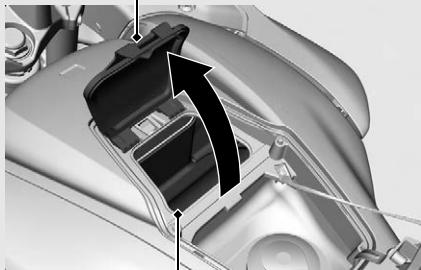

Shelter pocket

Opening

- ① Open the shelter lid. ➡ P.42
- ② Pull up the rear of the pocket lid.

Closing

- ① Push down the rear of the pocket lid until it locks in place.
 - ▶ Make sure that the tab is locked securely in position by pulling up lightly on the rear of the pocket lid.
 - ▶ The lock automatically locks when closed.
- ② Never exceed the maximum weight limit.

Maximum Weight: 1.0 lb (0.5 kg)

- ▶ Do not store any items that are flammable or susceptible to heat damage.

Tool Kit/U-shaped Lock

The tool kit is located under the seat. There is also space to store a U-shaped lock.

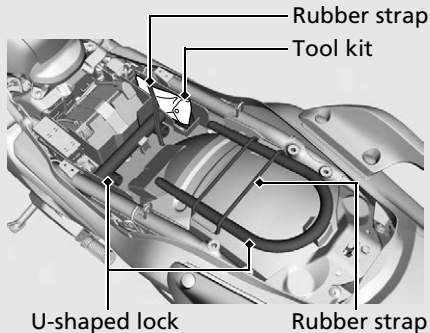

- Some U-shaped locks may not fit in the compartment due to their size or design.

Removing the seat ➔ P.73

Document Bag

The document bag is located underside of the seat.

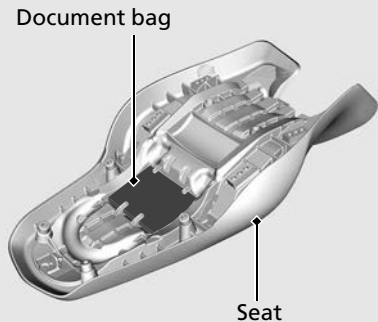

Removing the seat ➔ P.73

Storage Equipment *(Continued)*

Helmet holder

The helmet holder is located under the seat.

A helmet set wire is in the tool kit.

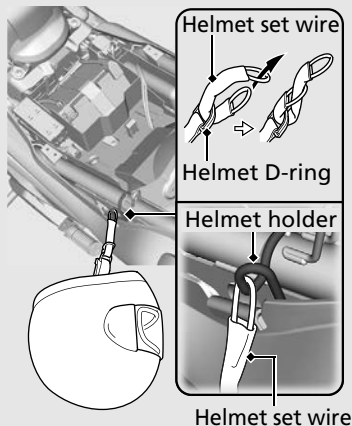

► Use the helmet holder only when parked.

► **Removing the seat** ➔ P.73

⚠ WARNING

Riding with a helmet attached to the holder can interfere with the rear wheel or suspension and could cause a crash in which you can be seriously hurt or killed.

Use the helmet holder only while parked. Do not ride with a helmet secured by the holder.

Maintenance

Please read “Importance of Maintenance” and “Maintenance Fundamentals” carefully before attempting any maintenance. Refer to “Specifications” for service data.

An optional larger tool kit may be available. Check with your Honda dealer’s parts department.

Importance of Maintenance	P. 48	Coolant	P. 83
Maintenance Schedule	P. 50	Brakes	P. 85
Maintenance Fundamentals	P. 53	Side Stand	P. 89
Removing & Installing Body Components ...	P. 68	Drive Chain	P. 90
Battery	P. 68	Clutch	P. 94
Center Lower Fairing.....	P. 69	Throttle	P. 97
Clip.....	P. 70	Crankcase Breather	P. 98
Right Under Fairing	P. 71	Other Adjustments	P. 99
Right Under Fairing Lid.....	P. 72	Headlight Aim	P. 99
Seat	P. 73		
Spark Plug	P. 74		
Engine Oil	P. 77		

Importance of Maintenance

Importance of Maintenance

Keeping your motorcycle well-maintained is absolutely essential to your safety and to protect your investment, obtain maximum performance, avoid breakdowns, and reduce air pollution. Maintenance is the owner's responsibility. Be sure to inspect your motorcycle before each ride, and perform the periodic checks specified in the Maintenance Schedule. ➤ P. 50

WARNING

Improperly maintaining your motorcycle or failing to correct a problem before you ride can cause a crash in which you can be seriously hurt or killed.

Always follow the inspection and maintenance recommendations and schedules in this owner's manual.

For information about the exhaust emission and noise emission requirements of the U.S. Environmental Protection Agency (EPA), the California Air Resources Board (CARB), and Environment Canada (EC). ➤ P. 131

USA

Maintenance, replacement or repair of the emission control devices and systems may be performed by any motorcycle repair establishment or individual using parts that are "certified" to EPA standards.

Maintenance Safety

Always read the maintenance instructions before you begin each task, and make sure that you have the tools, parts, and skills required. We cannot warn you of every conceivable hazard that can arise in performing maintenance. Only you can decide whether or not you should perform a given task.

Follow these guidelines when performing maintenance.







- Stop the engine and remove the key.
- Place your motorcycle on a firm, level surface using the side stand or a maintenance stand to provide support.
- Allow the engine, muffler, brakes, and other high-temperature parts to cool before servicing as you can get burned.
- Run the engine only when instructed, and do so in a well-ventilated area.

Maintenance Schedule



The maintenance schedule specifies the maintenance requirements necessary to ensure safe, dependable performance, and proper emission control.

Maintenance work should be performed in accordance with Honda's standards and specifications by properly trained and equipped technicians. Your dealer meets all of these requirements. Keep an accurate record of maintenance to help ensure that your motorcycle is properly maintained. Make sure that whomever performs the maintenance completes this record.

All scheduled maintenance is considered a normal owner operating cost and will be charged for by your dealer. Retain all receipts. If you sell the motorcycle, these receipts should be transferred with the motorcycle to the new owner.

Items		Frequency*1							Refer to page		
		× 1,000 mi	0.6	4	8	12	16	20		24	
		× 1,000 km	1.0	6.4	12.8	19.2	25.6	32.0		38.4	
Emission-related Items	Fuel Line				I		I		I	-	
	Throttle Operation				I		I		I	97	
	Air Cleaner*2					R			R	-	
	Crankcase Breather*3			C	C	C	C	C	C	98	
	Spark Plug		Every 16,000 mi (25,600 km): I		Every 32,000 mi (51,200 km): R					74	
	Valve Clearance				I		I		I	-	
	Engine Oil		Initial = 600 mi (1,000 km) or 1 month: R Regular = Every 8,000 mi (12,800 km) or 12 months: R							77	
	Engine Oil Filter			R		R		R		R	79
	Clutch Oil Filter		CTX700D	R				R			81
	Engine Idle Speed			I	I	I	I	I	I	I	-
	Radiator Coolant*5				I		I		R	83	
	Cooling System				I		I		I	-	
Evaporative Emission Control System*4						I		I	-		





























































Maintenance Level

-  : Intermediate. We recommend service by your dealer, unless you have the necessary tools and are mechanically skilled. Procedures are provided in an official Honda Service Manual (▶ P. 137).
-  : Technical. In the interest of safety, have your motorcycle serviced by your dealer.

Maintenance Legend

- I** : Inspect (clean, adjust, lubricate, or replace, if necessary)
- R** : Replace
- L** : Lubricate
- C** : Clean

Maintenance Schedule

Items		Frequency*1								Refer to page	
		x 1,000 mi	0.6	4	8	12	16	20	24		
		x 1,000 km	1.0	6.4	12.8	19.2	25.6	32.0	38.4		
Non-Emission-Related Items	Drive Chain	Every 500 mi (800 km):   L								90	
	Brake Fluid*5					 R			 R	85	
	Brake Pads Wear									86	
	Brake System									85	
	Brake Light Switch									88	
	Brake Lock Operation		CTX700D								87
	Headlight Aim									99	
	Clutch System		CTX700/A								94
	Side Stand									89	
	Suspension										-
	Nuts, Bolts, Fasteners										-
	Wheels/Tires										64
	Steering Head Bearings										-

Notes:

*1 : At higher odometer readings, repeat at the frequency interval established here.

*2 : Service more frequently when riding in unusually wet or dusty areas.

*3 : Service more frequently when riding in rain or at full throttle.

*4 : 50 STATE (meets California).

*5 : Replace every 2 years, or at indicated odometer interval, whichever comes first. Replacement requires mechanical skill.

Pre-ride Inspection

To ensure safety, it is your responsibility to perform a pre-ride inspection and make sure that any problem you find is corrected. A pre-ride inspection is a must, not only for safety, but because having a breakdown, or even a flat tire, can be a major inconvenience.

Check the following items before you get on your motorcycle:

- Tire tread wear and air pressures are within limits. ➤ P. 63
- Lights, horn, and turn signals operate normally.
- Check the condition of the drive chain. Adjust slack and lubricate as needed. ➤ P. 90

Check the following items if you are carrying a passenger or cargo:

- Combined weight is within load limits. ➤ P. 143
- Cargo is secured properly.

Check the following items after you get on your motorcycle:

- Throttle action moves smoothly without binding. ➤ P. 97
- Brake lever and pedal operate normally.
- Check the fuel level and refuel when needed. ➤ P. 21, 22, 42
- Engine stop switch functions properly. ➤ P. 28, 31

Check the following items at regular intervals:

- Oil level is between the upper and lower level marks. ➤ P. 77
- Brake fluid level is
Front: above the (LOWER) level mark. ➤ P. 85
Rear: between the (UPPER) and (LOWER) level marks. ➤ P. 85
- Engine coolant level is between the (UPPER) and (LOWER) level marks. ➤ P. 83
- Side stand functions properly. ➤ P. 89
- **CTX700D only** Parking brake works properly. ➤ P. 87

Periodic Checks

You should also perform other periodic maintenance checks at least once a month regardless of how often you ride, or more often if you ride frequently.

Also, check the odometer reading against the Maintenance Schedule and perform all maintenance that is due. ➤ P. 50

Tires and wheels	Check the air pressure (➤ P. 63), examine tread for wear and damage (➤ P. 63), and check the wheels for damage.
Fluid levels	Check the engine oil level (➤ P. 77), engine coolant level (➤ P. 83), and brake fluid level (➤ P. 85).
Lights	Check that the headlight, position lights, brake light, tail light, turn signals and license plate light are working properly.
Controls	Check the freeplay of the clutch lever (CTX700/A only) (➤ P. 94) and throttle grip (➤ P. 97).
Drive chain	Check the slack (➤ P. 90), adjust the slack (➤ P. 91), and lubricate (➤ P. 61) as needed.
Fuses	Check that you have a full supply of spare fuses.
Nuts & bolts	Check the major nuts and bolts, and tighten as needed.

Replacing Parts

Always use Honda Genuine Parts or their equivalents to ensure reliability and safety.

When ordering colored components, specify the model name, color, and code mentioned on the color label. The color label is attached to the frame under the seat.  P. 73

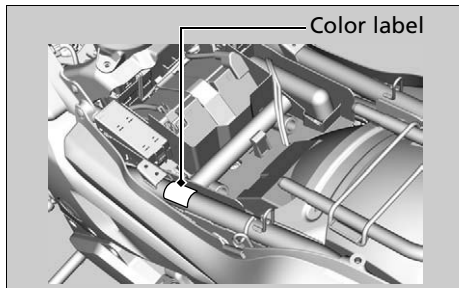

WARNING

Installing non-Honda parts may make your motorcycle unsafe and cause a crash in which you can be seriously hurt or killed.

Always use Honda Genuine Parts or equivalents that have been designed and approved for your motorcycle.

Battery

Your motorcycle has a maintenance-free type battery. You do not have to check the battery electrolyte level or add distilled water. Clean the battery terminals if they become dirty or corroded.

Do not remove the battery cap seals. There is no need to remove the cap when charging.

What to do in an emergency

If any of the following occur, immediately see your doctor.

- Electrolyte splashes into your eyes:
 - ▶ Wash your eyes repeatedly with cool water for at least 15 minutes. Using water under pressure can damage your eyes.
- Electrolyte splashes onto your skin:
 - ▶ Remove affected clothing and wash your skin thoroughly using water.

- Electrolyte splashes into your mouth:
 - ▶ Rinse mouth thoroughly with water, and do not swallow.

WARNING

The battery gives off explosive hydrogen gas during normal operation.

A spark or flame can cause the battery to explode with enough force to kill or seriously hurt you.

Wear protective clothing and a face shield, or have a skilled mechanic do the battery servicing.

WARNING: Battery posts, terminals, and related accessories contain lead and lead compounds.

Wash your hands after handling.

■ Cleaning the Battery Terminals

1. Remove the battery. ➤ P. 68
2. If the terminals are starting to corrode and are coated with a white substance, wash with warm water and wipe clean.
3. If the terminals are heavily corroded, clean and polish the terminals with a wire brush or sandpaper. Wear safety glasses.

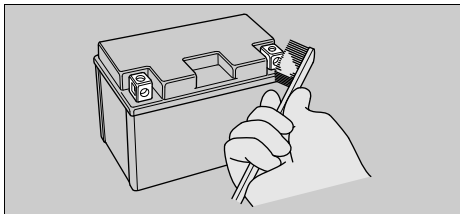

4. After cleaning, reinstall the battery.

The battery has a limited life span. Consult your dealer about when you should replace the battery. Always replace the battery with another maintenance-free battery of the same type.

■ Charging

If you use electrical accessories that drain the battery or you do not ride frequently, we recommend that you charge the battery every 30 days using a charger designed specifically for your Honda, which can be purchased from your dealer. Read the information that came with your battery charger and follow the instructions on the battery. Avoid using an automobile-type battery charger, as these can overheat a motorcycle battery and cause permanent damage.

Make sure the ignition switch is in the OFF position before charging the battery.

NOTICE

Improper charging can damage the battery. If you can't charge the battery or it appears unable to hold a charge, contact your dealer.

Maintenance Fundamentals

NOTICE

Jump starting using an automobile battery can damage your motorcycle's electrical system and is not recommended. Bump starting is also not recommended.

NOTICE

Installing non-Honda electrical accessories can overload the electrical system, discharging the battery and possibly damaging the system.

Fuses

Fuses protect the electrical circuits on your motorcycle. If something electrical on your motorcycle stops working, check for and replace any blown fuses. ➤ P. 118

Inspecting and Replacing Fuses

Turn off the ignition switch to remove and inspect fuses. If a fuse is blown, replace with a fuse of the same rating. For fuse ratings, see "Specifications." ➤ P. 145

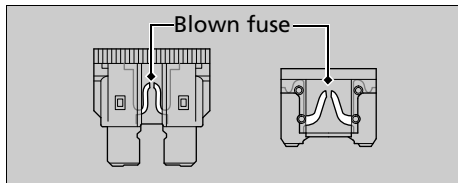

NOTICE

Replacing a fuse with one that has a higher rating greatly increases the chance of damage to the electrical system.

If a fuse fails repeatedly, you likely have an electrical fault. Have your motorcycle inspected by your dealer.

Engine Oil

Engine oil consumption varies and oil quality deteriorates according to riding conditions and time elapsed.

Check the engine oil level regularly, and add the recommended engine oil if necessary. Dirty oil or old oil should be changed as soon as possible.

Selecting the Engine Oil

For recommended engine oil, see "Specifications." P. 144

If you use non-Honda engine oil, check the label to make sure that the oil satisfies all of the following standards:

- JASO T 903 standard*1: MA
- SAE standard*2: 10W-30
- API classification*3: SG or higher

- *1. The JASO T 903 standard is an index for engine oils for 4-stroke motorcycle engines. There are two classes: MA and MB. For example, the following label shows the MA classification.

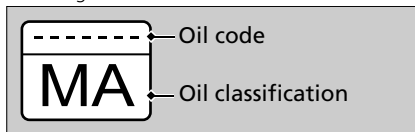

- *2. The SAE standard grades oils by their viscosity.
- *3. The API classification specifies the quality and performance rating of engine oils. Use SG or higher oils, excluding oils marked as "Energy Conserving" or "Resource Conserving" on the circular API service symbol.

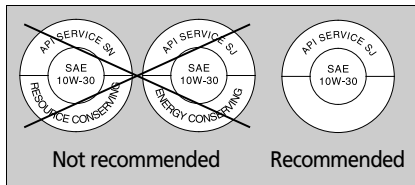

Brake Fluid

Do not add or replace brake fluid, except in an emergency. Use only fresh brake fluid from a sealed container. If you do add fluid, have the brake system serviced by your dealer as soon as possible.

NOTICE

Brake fluid can damage plastic and painted surfaces. Wipe up spills immediately and wash thoroughly.

Recommended brake fluid:

Honda DOT 4 Brake Fluid or equivalent

WARNING

Clean filler cap before removing. Use only DOT 4 fluid from a sealed container.

Drive Chain

The drive chain must be inspected and lubricated regularly. Inspect the chain more frequently if you often ride on bad roads, ride at high speed, or ride with repeated fast acceleration. ➔ P. 90

If the chain does not move smoothly, makes strange noises, has damaged rollers, has loose pins, has missing O-rings, or kinks, have the chain inspected by your dealer.

Also inspect the front sprocket and rear wheel sprocket. If either has worn or damaged teeth, have the sprocket replaced by your dealer.

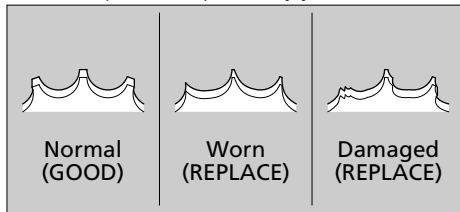
**NOTICE**

Use of a new chain with worn sprockets will cause rapid chain wear.

Cleaning and Lubricating

After inspecting the slack, clean the chain and sprockets while rotating the rear wheel. Use a dry cloth with chain cleaner designed specifically for O-ring chains, or neutral detergent. Use a soft brush if the chain is dirty. After cleaning, wipe dry and lubricate with the recommended lubricant.

Recommended lubricant:

Pro Honda HP Chain Lube or equivalent

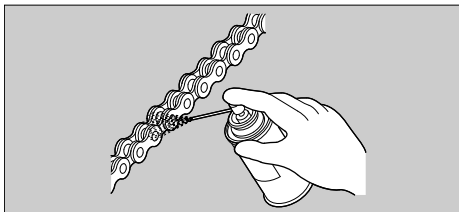

Maintenance Fundamentals

Do not use a steam cleaner, a high pressure cleaner, a wire brush, volatile solvent such as gasoline and benzene, abrasive cleaner, chain cleaner or lubricant NOT designed specifically for O-ring chains as these can damage the rubber O-ring seals.

Avoid getting lubricant on the brakes or tires. Avoid applying excess chain lubricant to prevent spray onto your clothes and the motorcycle.

Recommended Coolant

Pro Honda HP Coolant is a pre-mixed solution of antifreeze and distilled water.

Concentration:

50% antifreeze and 50% distilled water

A concentration of antifreeze below 40% will not provide proper corrosion and cold temperature protection.

A concentration of up to 60% will provide better protection in colder climates.

NOTICE

Using coolant not specified for aluminum engines or using ordinary tap water can cause corrosion.

Crankcase Breather

Service more frequently when riding in rain, at full throttle, or after the motorcycle is washed or overturned. Service if the deposit level can be seen in the transparent section of the drain tube.

If the drain tube overflows, the air filter may become contaminated with engine oil causing poor engine performance. ➤ P. 98

Tires (Inspecting/Replacing)

Checking the Air Pressure

Visually inspect your tires and use an air pressure gauge to measure the air pressure at least once a month or any time you think the tires look low. Always check air pressure when your tires are cold.

Inspecting for Damage

Inspect the tires for cuts, slits, or cracks that exposes fabric or cords, or nails or other foreign objects embedded in the side of the tire or the tread. Also inspect for any unusual bumps or bulges in the side walls of the tires.

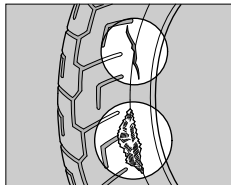

Inspecting for Abnormal Wear

Inspect the tires for signs of abnormal wear on the contact surface.

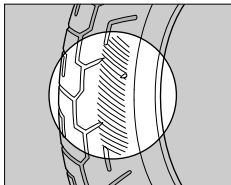

Inspecting Tread Depth

Inspect the tread wear indicators. If they become visible, replace the tires immediately. For safe riding, you should replace the tires when the minimum tread depth is reached.

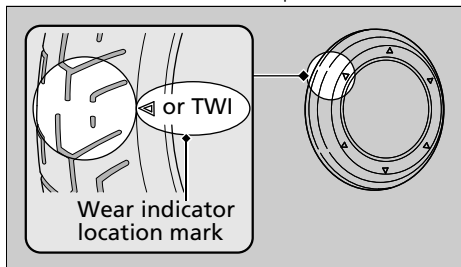

⚠️ WARNING

Riding on tires that are excessively worn or improperly inflated can cause a crash in which you can be seriously hurt or killed.

Follow all instructions in this owner's manual regarding tire inflation and maintenance.

Have your tires replaced by your dealer. For recommended tires, air pressure and minimum tread depth, see "Specifications."

➤ P. 144

Follow these guidelines whenever you replace tires.

- Use the recommended tires or equivalents of the same size, construction, speed rating, and load range.
- Have the wheel balanced with Honda Genuine balance weights or equivalent after the tire is installed.
- Do not install a tube inside a tubeless tire on this motorcycle. Excessive heat build-up can cause the tube to burst.
- Use only tubeless tires on this motorcycle. The rims are designed for tubeless tires, and during hard acceleration or braking, a tube-type tire could slip on the rim and cause the tire to rapidly deflate.

WARNING

Installing improper tires on your motorcycle can adversely affect handling and stability, and can cause a crash in which you can be seriously hurt or killed.

Always use the size and type of tires recommended in this owner's manual.

Tire Service Life

The service life of your tires is dependent on many factors, including, but not limited to, riding habits, road conditions, vehicle loading, tire air pressure, maintenance history, speed, and environmental conditions (even when the tires are not in use).

In addition to your regular inspections and maintenance, it is recommended that you have annual inspections performed once the tires reach 5 years old. It is also recommended that all tires be removed from service after 10 years from the date of manufacture, regardless of their condition or state of wear.

The last four digits of the TIN (tire identification number) indicate the date of manufacture.

Tire Identification Number (TIN)

The tire identification number (TIN) is a group of numbers and letters located on the sidewall of the tire.

① ② ③

DOT XXXX XXXX 22 09

DOT: This indicates that the tire meets all requirements of the U.S. Department of Transportation.

- ① XXXX: Factory code
- ② XXXX: Tire type code
- ③ 22 09: Date of manufacture (week & year).
Example: week 22 in year 09.

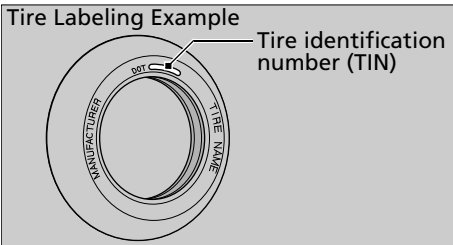

Air Cleaner

This motorcycle is equipped with a viscous type air cleaner element which cannot be cleaned with compressed air or otherwise without degrading its performance.

If the filter becomes dirty, replace it with a new one.

Battery

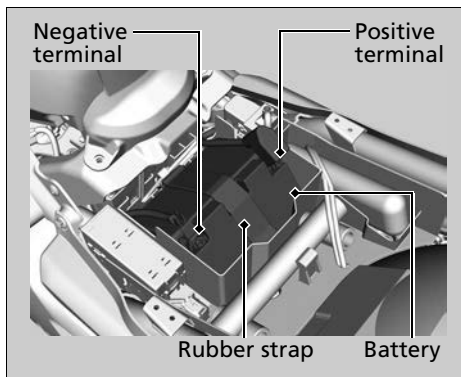

Removal

Make sure the ignition switch is off.

1. Remove the seat. ➤ P. 73
2. Unhook the rubber strap.
3. Disconnect the negative \ominus terminal from the battery.
4. Disconnect the positive \oplus terminal from the battery.
5. Remove the battery taking care not to drop the terminal nuts.

Installation

Install the parts in the reverse order of removal. Always connect the positive \oplus terminal first. Make sure that bolts and nuts are tight.

Make sure the clock is set to the proper time after the battery is reconnected. ➤ P. 25
For proper handling of the battery, see "Maintenance Fundamentals." ➤ P. 56
"Battery Goes Dead." ➤ P. 115

Center Lower Fairing

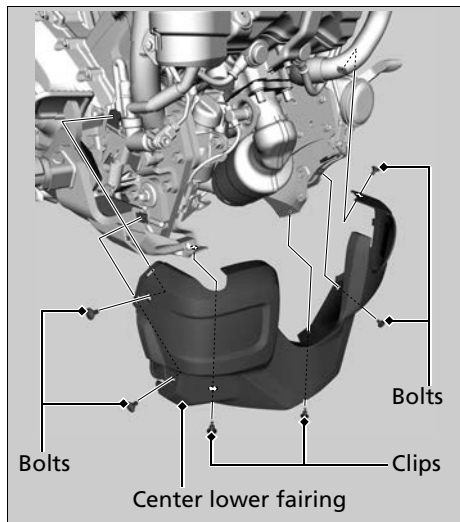

Removal

1. Remove the right under fairing lid. ► P. 72
2. Remove the bolts and clips. ► P. 70
3. Remove the center lower fairing.

Installation

Install the parts in the reverse order of removal.

Clip

Removal

1. Loosen the pin by a Phillips screwdriver.
2. Pull the clip out of the hole.

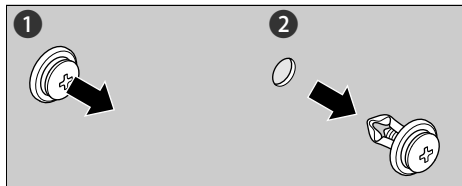

Installation

1. Insert the clip into the hole.
2. Push the pin in.

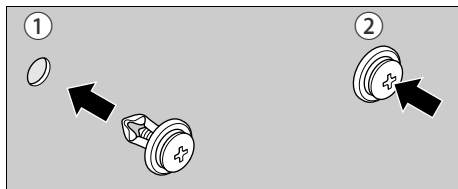

Right Under Fairing

CTX700D only

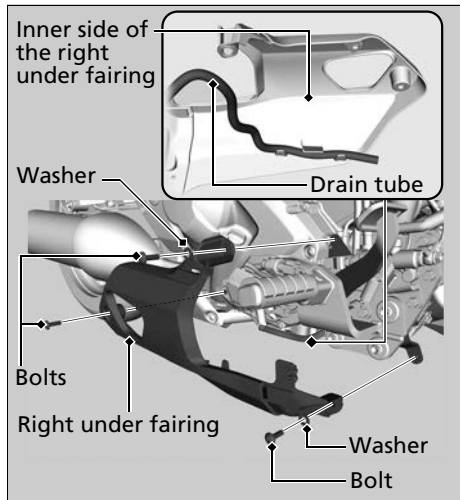

Removal

1. Remove the right under fairing lid. ► P. 72
2. Remove the center lower fairing. ► P. 69
3. Remove the bolts and washers.
4. Remove the right under fairing by releasing the drain tube.

Installation

1. Route the drain tube inner side of the right under fairing as shown in the image.
2. Install the parts in the reverse order of removal.

Right Under Fairing Lid

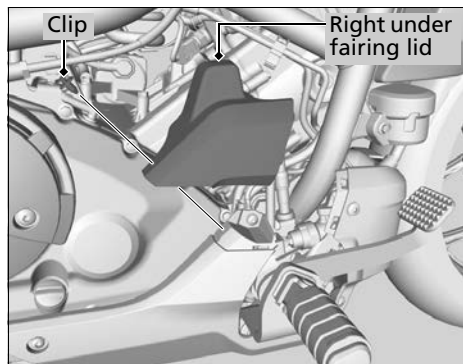

Removal

1. Remove the clip. ► P. 70
2. Remove the right under fairing lid.

Installation

Install the parts in the reverse order of removal.

Seat

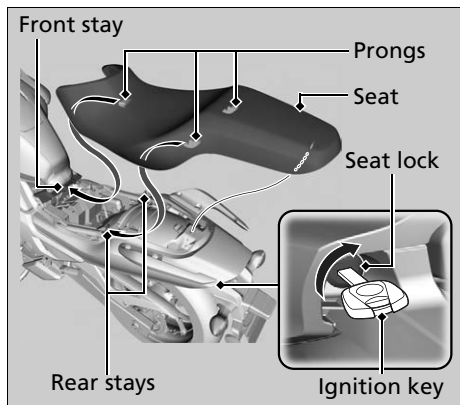

Removal

1. Insert the ignition key into the seat lock, and turn it clockwise.
2. Pull the seat back and up.

Installation

1. Insert the front and rear prongs into the front and rear stays on the frame.
2. Push forward and down on the rear of the seat until it locks in place. Make sure that the seat is locked securely in position to pull it up lightly.

The seat locks automatically when closed. Take care not to lock your key in the underseat compartment.

Checking Spark Plug

For the recommended spark plugs, see “Specifications.” ➤ P. 144

Use only the recommended type of spark plugs in the recommended heat range.

NOTICE

Using spark plug an improper heat range can cause engine damage.

This motorcycle uses spark plugs that have an iridium coated center electrode.

Be sure to observe the following when servicing the spark plugs.

- Do not clean the spark plugs. If an electrode is contaminated with accumulated objects or dirt, replace the spark plug with a new one.
- To check the spark plug gap, use only a “wire-type feeler gauge.” To prevent damaging the iridium coating of the center electrode, never use a “leaf-type feeler gauge.”
- Do not adjust the spark plug gap. If the gap is out of specification, replace the spark plug with a new one.

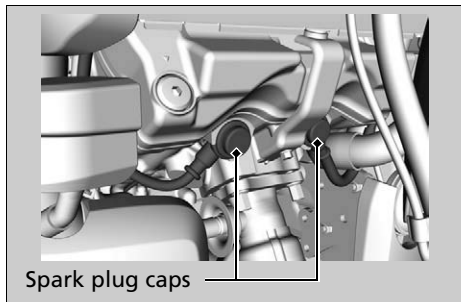

1. Disconnect the spark plug caps from the spark plugs.
2. Clean any dirt from around the spark plug bases.
3. Remove the spark plugs using a suitable spark plug wrench.

4. Inspect the electrodes and center porcelain for deposits, erosion or carbon fouling. If the corrosion or deposit is heavy, replace the plug.
5. Make sure that a 1.1 mm wire-type feeler gauge cannot be inserted between the spark plug gap. If the gauge fits in the gap, replace the plug with a new one.
6. Make sure the plug washer is in good condition.

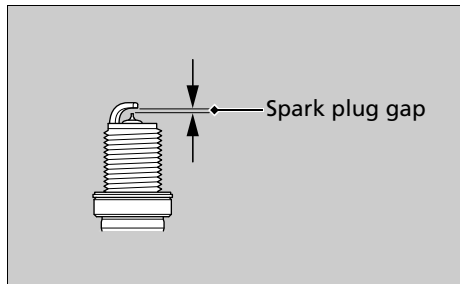

Spark Plug ► Checking Spark Plug

7. Install the new spark plugs. With the plug washers attached, thread the spark plugs in by hand to prevent cross-threading.
8. Tighten each spark plug:
 - If the old plug is good:
 - 1/8 turn after it seats
 - If installing a new plug, tighten it twice to prevent loosening:
 - a) First, tighten the plug:
 - NGK: 2/3 turn after it seats.
 - b) Then loosen the plug.
 - c) Next, tighten the plug again:
 - 1/8 turn after it seats.
9. Reinstall the spark plug caps. Avoid pinching any cables or wires.

NOTICE

Improperly tightened spark plug can damage the engine. If a plug is too loose, a piston may be damaged. If a plug is too tight, the threads may be damaged.

Checking the Engine Oil

1. If the engine is cold, idle the engine for 3 to 5 minutes.
2. Turn the ignition switch off, and wait for 2 to 3 minutes.
3. Remove the oil fill cap/dipstick and wipe it clean.
4. Place your motorcycle in an upright position on a firm, level surface.
5. Insert the oil fill cap/dipstick until it seats, but don't screw it in.

Check that the oil level is between the upper level and lower level marks in the oil fill cap/dipstick.

6. Securely install the oil fill cap/dipstick.

CTX700/A

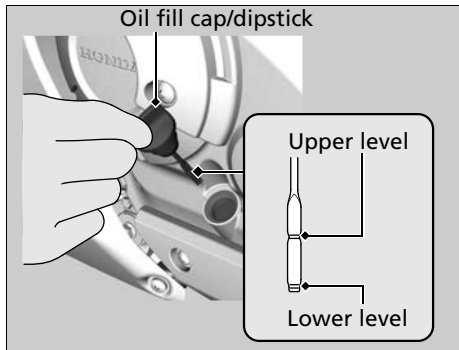

CTX700D

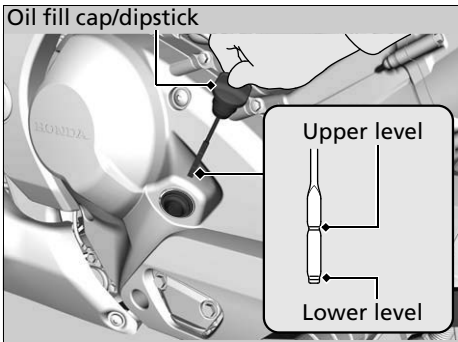

Adding Engine Oil

If the engine oil is below or near the lower level mark, add the recommended engine oil.

► P. 59, 144

1. Remove the oil fill cap/dipstick. Add the recommended oil until it reaches the upper level mark.

- Place your motorcycle in an upright position on a firm, level surface when checking the oil level.
 - Do not overfill above the upper level mark.
 - Make sure no foreign objects enter the oil filler opening.
 - Wipe up any spills immediately.
2. Securely reinstall the oil fill cap/dipstick.

NOTICE

Overfilling with oil or operating with insufficient oil can cause damage to your engine. Do not mix different brands and grades of oil. They may affect lubrication and clutch operation.

For the recommended oil and oil selection guidelines, see "Maintenance Fundamentals." ► P. 59

Changing Engine Oil & Filter

Changing the oil and filter requires special tools. We recommend that you have your motorcycle serviced by your dealer.

Use a new Honda Genuine oil filter or equivalent specified for your model.

NOTICE

Using the wrong oil filter can result in serious damage to the engine.

1. If the engine is cold, idle the engine for 3 to 5 minutes.
2. Turn the ignition switch off, and wait for 2 to 3 minutes.
3. Place on a firm, level surface and lower the side stand.
4. Place a drain pan under the drain bolt.

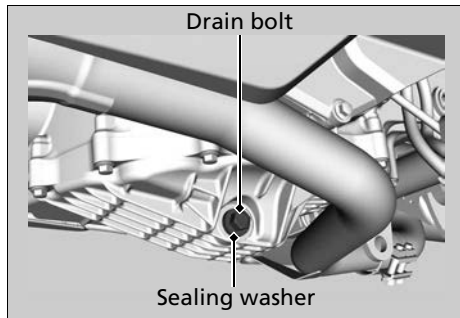

5. Remove the oil fill cap/dipstick, drain bolt, and sealing washer to drain the oil.
6. Remove the oil filter with a filter wrench and let the remaining oil drain out. Make sure the prior seal is not stuck to the engine.
 - Discard the oil and oil filter at an approved recycling center.

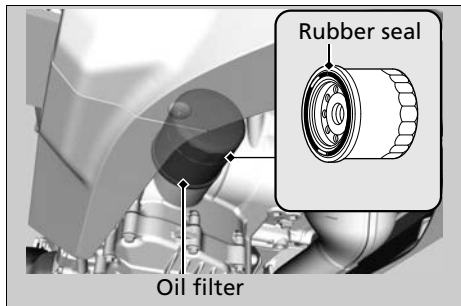

7. Apply a thin coat of engine oil to the rubber seal of a new oil filter.
8. Install the new oil filter and tighten.

Torque: 19 lbf·ft (26 N·m, 2.7 kgf·m).

9. Install a new sealing washer onto the drain bolt. Tighten the drain bolt.

Torque: 22 lbf·ft (30 N·m, 3.1 kgf·m).

10. Fill the crankcase with the recommended oil (► P. 59, 144) and install the oil fill cap/dipstick.

Required oil

CTX700/A

When changing oil & engine oil filter:

3.6 US qt (3.4 liters)

When changing oil only:

3.3 US qt (3.1 liters)

CTX700D

When changing oil & engine oil filter:

3.6 US qt (3.4 liters)

When changing oil only:

3.4 US qt (3.2 liters)

11. Check the oil level. ► P. 77
12. Check that there are no oil leaks.

Changing Clutch Oil Filter

CTX700D only

Use a new Honda Genuine clutch oil filter or equivalent specified for your model.

NOTICE

Using the wrong clutch oil filter can result in serious damage to the transmission.

1. Follow the steps 1-6 of Changing Engine Oil & Filter. ► P. 79
2. Remove the right under fairing. ► P. 71

3. Remove the clutch oil filter cover, clutch oil filter and spring by removing the clutch oil filter cover bolts.
 - Discard the oil and clutch oil filter at an approved recycling center.

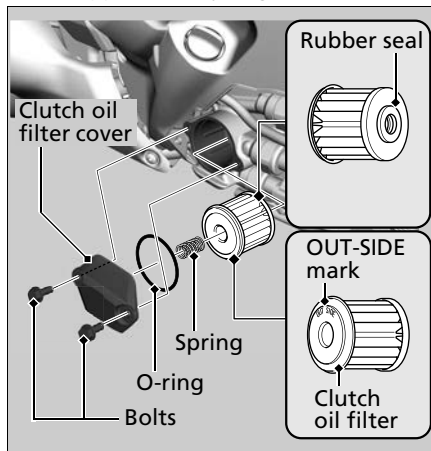

Engine Oil ► Changing Clutch Oil Filter

4. Install the new clutch oil filter with the rubber seal facing in, toward the engine. You will see "OUT-SIDE" mark on the clutch oil filter body, toward the filter cover.
5. Replace the O-ring and apply a thin coat of engine oil to the new O-ring before installing it.
6. Install the spring and the clutch oil filter cover.
7. Install the clutch oil filter cover bolts and tighten.
8. Apply a thin coat of engine oil to the rubber seal of a new engine oil filter.
➤ P. 80
9. Install a new engine oil filter and tighten.

Torque: 19 lbf·ft (26 N·m, 2.7 kgf·m).

10. Install the new sealing washer onto the drain bolt. Tighten the drain bolt.

Torque: 22 lbf·ft (30 N·m, 3.1 kgf·m).

11. Fill the crankcase with the recommended oil (➤ P. 59) and install the oil fill cap/dipstick.

Required oil

When changing oil, engine oil filter & clutch oil filter:

3.6 US qt (3.4 liters)

12. Check the oil level. ➤ P. 77
13. Check that there are no oil leaks.
14. Install the right under fairing.

Checking the Coolant

Checking the coolant level in the reserve tank while the engine is cold.

1. Place your motorcycle on a firm, level surface.
2. Hold your motorcycle in an upright position.
3. Check that the coolant level is between the UPPER level and LOWER level marks in the reserve tank.

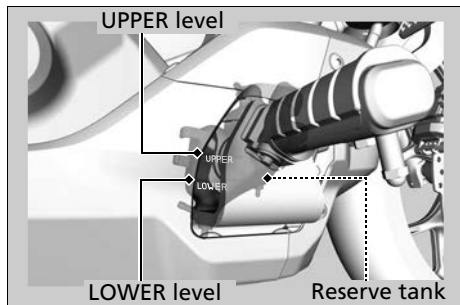

If the coolant level is dropping noticeably or the reserve tank is empty, you likely have a serious leak. Have your motorcycle inspected by your dealer.

Adding Coolant

If the coolant level is below the LOWER level mark, add the recommended coolant (▶ P. 62) until the level reaches the UPPER level mark.

Add fluid only from the reserve tank cap and do not remove the radiator cap.

Coolant ► Changing Coolant

1. Remove the center lower fairing. ► P. 69
2. Remove the reserve tank cap and add fluid while monitoring the coolant level.
 - Do not overfill above the UPPER level mark.
 - Make sure no foreign objects enter the reserve tank opening.
3. Securely reinstall the cap.
4. Install the center lower fairing.

⚠ WARNING

Removing the radiator cap while the engine is hot can cause the coolant to spray out, potentially scalding you.

Always let the engine and radiator cool down before removing the radiator cap.

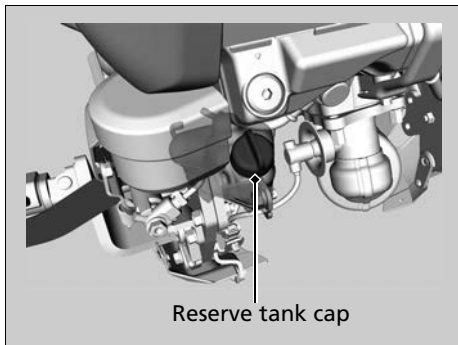

Changing Coolant

Have your dealer change the coolant unless you have the proper tools and are mechanically qualified.

Checking Brake Fluid

1. Place your motorcycle in an upright position on a firm, level surface.
2. **Front** Check that the brake fluid reservoir is horizontal and that the fluid level is above the LOWER level mark.
Rear Check that the brake fluid reservoir is horizontal and that the fluid level is between the LOWER level and UPPER level marks.

If the brake fluid level in either reservoir is below the LOWER level mark or the brake lever and pedal freeplay becomes excessive, inspect the brake pads for wear. If the brake pads are not worn, you most likely have a leak. Have your motorcycle inspected by your dealer.

Front

Front brake fluid reservoir

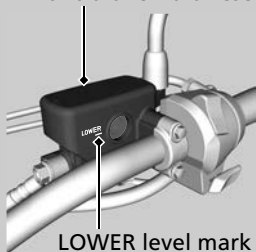

Rear

Rear brake fluid reservoir

UPPER
level mark

LOWER
level mark

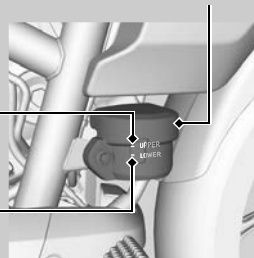

Inspecting the Brake Pads

Check the condition of the brake pad wear indicators.

The pads need to be replaced if a brake pad is worn to the indicator.

1. **Front** Inspect the brake pads from below the brake caliper.
2. **Rear** Inspect the brake pads from the rear right of the motorcycle.

If necessary have the pads replaced by your dealer.

Always replace both left and right brake pads at the same time.

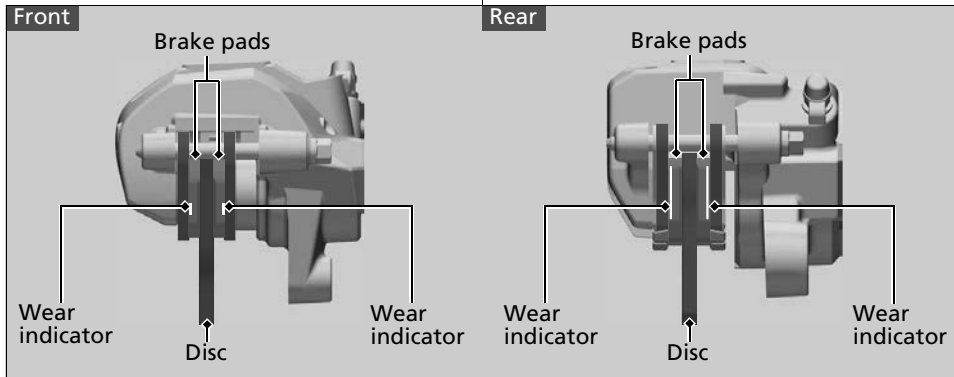

Inspecting the Parking Brake

CTX700D only

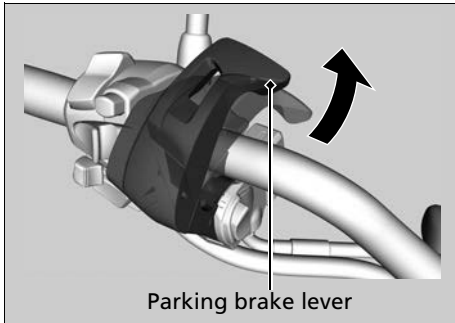

Place your motorcycle on a firm, level surface. Stop the engine and push your motorcycle while applying the parking brake lever to check the efficacy of the parking brake.

If the efficacy of the parking brake becomes weak, have the brake adjusted by your dealer.

Adjusting the Brake Light Switch

Check the operation of the brake light switch.

1. Remove the right under fairing lid by removing the clip. ➤ P. 70

2. Hold the brake light switch and turn the adjusting nut in the direction A if the switch operates too late, or turn the nut in the direction B if the switch operates too soon.

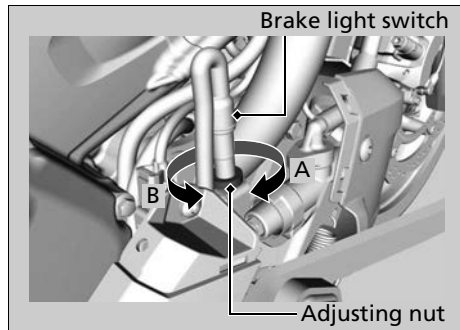

Checking the Side Stand

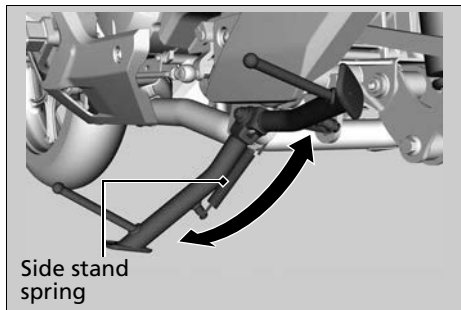

1. Check that the side stand operates smoothly. If the side stand is stiff or squeaky, clean the pivot area and lubricate the pivot bolt with clean grease.
2. Check the spring for damage or loss of tension.

3. **CTX700/A**
Sit on the motorcycle, put the transmission in Neutral, and raise the side stand.

CTX700D

Sit on the motorcycle and raise the side stand.

4. **CTX700/A**

Start the engine, pull the clutch lever in, and shift the transmission into gear.

CTX700D

Start the engine and press the D/S side of N-D switch to switch the transmission into D mode.

5. Lower the side stand all the way. The engine should stop as you lower the side stand. If the engine doesn't stop, have your motorcycle inspected by your dealer.

Inspecting the Drive Chain Slack

Check the drive chain slack at several points along the chain. If the slack is not constant at all points, some links may be kinked and binding.

Have the chain inspected by your dealer.

1. Shift the transmission to Neutral. Stop the engine.
2. Place your motorcycle on the side stand on a level surface.

3. Check the slack in the lower half of the drive chain midway between the sprockets.

Drive chain slack:

1 to 1 3/8 in (25 to 35 mm)

- Do not ride your motorcycle if the slack exceeds 1 15/16 in (50 mm).

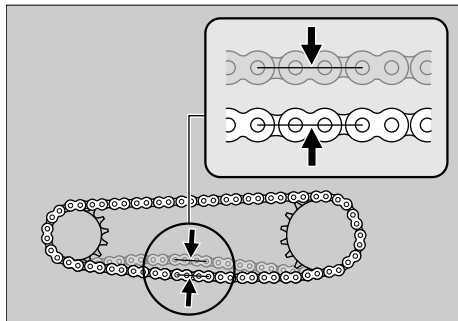

4. Roll the motorcycle forward and check that the chain moves smoothly.

5. Inspect the sprockets. ► P. 61
6. Clean and lubricate the drive chain. ► P. 61

Adjusting the Drive Chain Slack

Adjusting the chain requires special tools. Have the drive chain slack adjusted by your dealer.

CTX700A/D only

When adjusting the drive chain slack, be careful not to damage the wheel speed sensor and pulser ring.

1. Shift the transmission to Neutral. Stop the engine.
2. Place your motorcycle on the side stand on a level surface.
3. Loosen the rear axle nut.
4. Loosen the lock nuts on both sides of the swingarm.

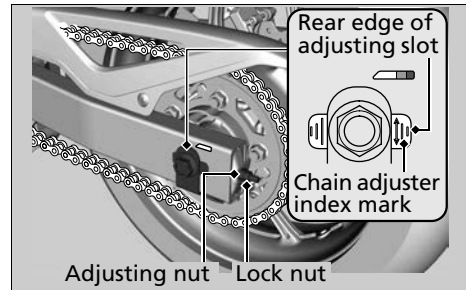
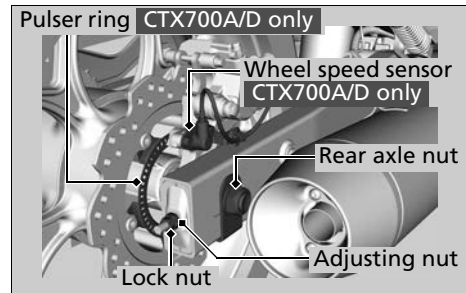

Drive Chain ► Adjusting the Drive Chain Slack

- Turn both adjusting nuts an equal number of turns until the correct drive chain slack is obtained. Turn the adjusting nuts clockwise to tighten the chain. Turn the adjusting nuts counterclockwise to provide more slack. Adjust the slack at a point midway between the front sprocket and the rear wheel sprocket. Check the drive chain slack. ➤ P. 90
- Check rear axle alignment by making sure the chain adjuster index marks align with the rear edge of the adjusting slots. Both marks should correspond. If the axle is misaligned, turn the right or left adjusting nuts until the marks are aligned and recheck chain slack.

- Remove the bolts and muffler end cover.

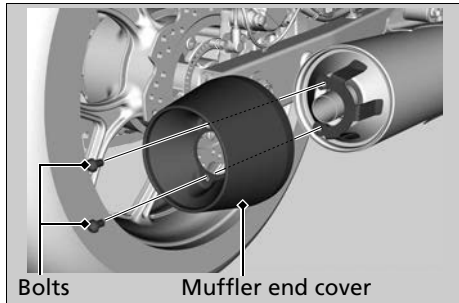

- Tighten the rear axle nut.

Torque: 72 lbf·ft (98 N·m, 10.0 kgf·m).

- Install the muffler end cover and tighten the bolts.

Torque: 7 lbf·ft (10 N·m, 1.0 kgf·m).

10. Tighten the drive chain adjusting nuts lightly, then hold the adjusting nuts and tighten the lock nuts.

Torque: 15 lbf·ft (21 N·m, 2.1 kgf·m).

11. Recheck drive chain slack.

If a torque wrench was not used for installation, see your dealer as soon as possible to verify proper assembly. Improper assembly may lead to loss of braking capacity.

Drive Chain ► Adjusting the Drive Chain Slack

Checking the Drive Chain Wear

Check the chain wear label when adjusting the drive chain. If the arrow mark on the chain adjuster plate enters the red zone on the label after the chain has been adjusted to the proper slack, the chain is excessively worn and must be replaced.

Chain: DID 520V0 or RK 520KHO

If necessary, have the drive chain replaced by your dealer.

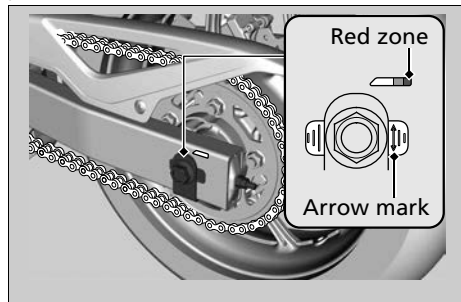

Checking the Clutch

CTX700/A only

Checking the Clutch Lever Freeplay

Check the clutch lever freeplay.

Freeplay at the clutch lever:

3/8 to 13/16 in (10 to 20 mm)

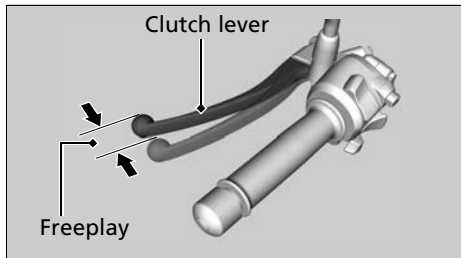

Check the clutch cable for kinks or signs of wear. If necessary have it replaced by your dealer.

Lubricate the clutch cable with a commercially available cable lubricant to prevent premature wear and corrosion.

NOTICE

Improper freeplay adjustment can cause premature clutch wear.

Adjusting the Clutch Lever Freeplay

CTX700/A only

Upper Adjustment

Attempt adjustment with the upper clutch cable adjuster first.

1. Loosen the upper lock nut.
2. Turn the upper clutch cable adjuster until the freeplay is $3/8$ to $13/16$ in (10 to 20 mm).
3. Tighten the upper lock nut and check the freeplay again.

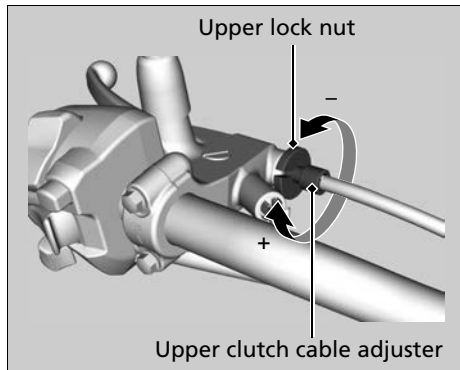

Lower Adjustment

If the upper clutch cable adjuster is threaded out near its limit, or the correct freeplay cannot be obtained, attempt adjustment with the lower clutch cable adjusting nut.

Clutch ► Adjusting the Clutch Lever Freeplay

1. Loosen the upper lock nut and turn the upper clutch cable adjuster all the way in (to provide maximum freeplay). Tighten the upper lock nut.
2. Loosen the lower lock nut.
3. Turn the adjusting nut until the clutch lever freeplay is $\frac{3}{8}$ to $\frac{13}{16}$ in (10 to 20 mm).
4. Tighten the lower lock nut and check the clutch lever freeplay.
5. Start the engine, pull the clutch lever in, and shift into gear. Make sure the engine does not stall and the motorcycle does not creep. Gradually release the clutch lever and open the throttle. Your motorcycle should move smoothly and accelerate gradually.

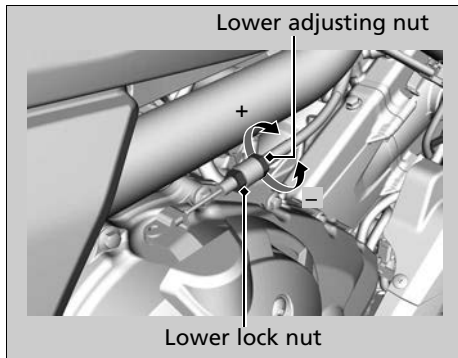

If proper adjustment cannot be obtained or the clutch does not work correctly, see your dealer.

Checking the Throttle

With the engine off, check that the throttle rotates smoothly from fully closed to fully open in all steering positions and throttle freeplay is correct. If the throttle does not move smoothly, close automatically, or if the cable is damaged, have the motorcycle inspected by your dealer.

Freeplay at the throttle grip flange:
1/16 to 1/4 in (2 to 6 mm)

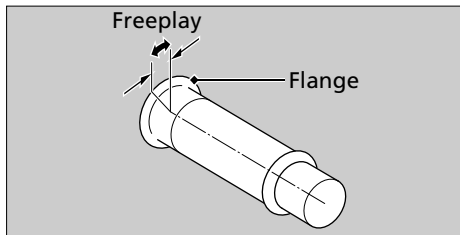

Adjusting the Throttle Freeplay

1. Slide the cable boot.
2. Loosen the lock nut.
3. Turn the adjuster until the freeplay is 1/16 to 1/4 in (2 to 6 mm).
4. Tighten the lock nut, return the cable boot, and inspect the throttle action again.

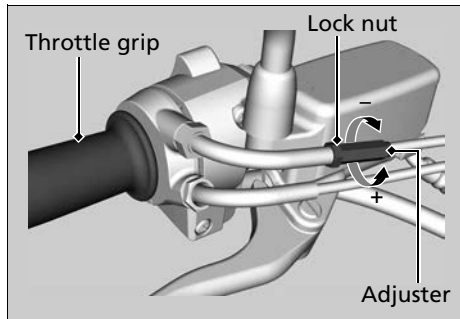

Cleaning the Crankcase Breather

1. Place a suitable container under the crankcase breather tube.
2. Remove the crankcase breather tube plug from the tube.
3. Drain deposits into a suitable container.
4. Install the crankcase breather tube plug.

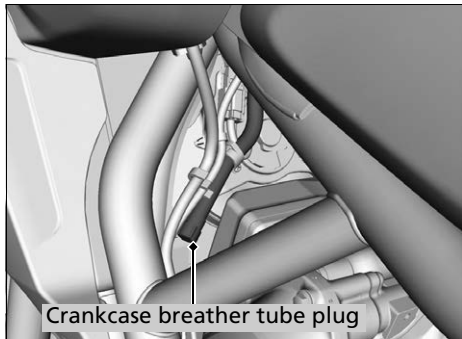

Adjusting the Headlight Aim

You can adjust vertical aim of the headlight for proper alignment. Turn the pinion in or out as necessary using a Phillips screwdriver provided in the tool kit.

Obey local laws and regulations.

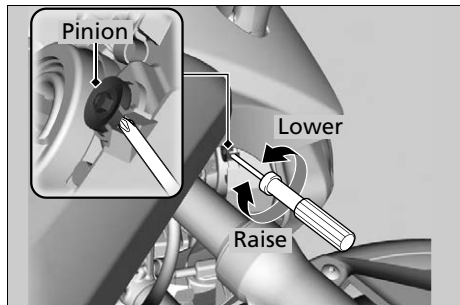

Troubleshooting

Engine Will Not Start	P. 101
Overheating (High coolant temperature indicator is on)	P. 102
Warning Indicators On or Flashing	P. 103
Low Oil Pressure Indicator	P. 103
PGM-FI (Programmed Fuel Injection)	
Malfunction Indicator Lamp (MIL)	P. 103
ABS (Anti-lock Brake System) Indicator	P. 104

If the “-” Indicator is Blinking in the Gear Position Window While Riding	P. 105
Other Warning Indication	P. 106
Fuel Gauge Failure Indication	P. 106
Tire Puncture	P. 107
Electrical Trouble	P. 115
Battery Goes Dead	P. 115
Burned-out Light Bulb	P. 115
Blown Fuse	P. 118

Starter Motor Operates But Engine Does Not Start

Check the following items:

- Check the correct engine starting sequence. ➤ P. 32, 33
- Check that there is gasoline in the fuel tank.
- Check if the PGM-FI malfunction indicator lamp (MIL) is on.
 - ▶ If the indicator light is on, contact your dealer as soon as possible.

Starter Motor Does Not Operate

Check the following items:

- Make sure the engine stop switch is in  (Run) position. ➤ P. 28, 31
- Check for a blown fuse. ➤ P. 118
- Check for a loose battery connection or battery terminal corrosion. ➤ P. 56, 68
- Check the condition of the battery ➤ P. 115

If the problem continues, have your motorcycle inspected by your dealer.

Overheating (High coolant temperature indicator is on)

The engine is overheating when the following occurs:

- High coolant temperature indicator comes on.
- Acceleration becomes sluggish.

If this occurs, pull safely to the side of the road and perform the following procedure. Extended fast idling may cause the high coolant temperature indicator to come on.

NOTICE

Continuing to ride with an overheated engine can cause serious damage to the engine.

1. Stop the engine using the ignition switch, and then turn the ignition switch to the ON position.

2. Check that the radiator fan is operating, and then turn the ignition switch to the OFF position.

If the fan is not operating:

Suspect a fault. Do not start the engine. Transport your motorcycle to your dealer.

If the fan is operating:

Allow the engine to cool with the ignition switch in the OFF position.

3. After the engine has cooled, inspect the radiator hose and check if there is a leak.

➔ P. 83

If there is a leak:

Do not start the engine. Transport your motorcycle to your dealer.

4. Check the coolant level in the reserve tank, and add coolant as necessary.

➔ P. 83

5. If 1-4 check normal, you may continue riding, but closely monitor the high coolant temperature indicator.

Low Oil Pressure Indicator

If the low oil pressure indicator comes on, pull safely to the side of the road and stop the engine.

NOTICE

Continuing to ride with low oil pressure can cause serious damage to the engine.

1. Check the engine oil level, and add oil as necessary. ➤ P. 77
2. Start the engine.
 - ▶ Only continue riding if the low oil pressure indicator goes off.

Rapid acceleration may momentarily cause the low oil pressure indicator to come on, especially if the oil is at or near the low level. If the low oil pressure indicator stays on when the oil level is at the proper level, stop the engine and contact your dealer.

If the engine oil level goes down rapidly, your motorcycle may have a leak or another serious problem. Have your motorcycle inspected by your dealer.

PGM-FI (Programmed Fuel Injection) Malfunction Indicator Lamp (MIL)

If the indicator comes on while riding, you may have a serious problem with the PGM-FI system. Reduce speed and have your motorcycle inspected by your dealer as soon as possible.

ABS (Anti-lock Brake System) Indicator

CTX700A/D only

If the indicator operates in one of the following ways, you may have a serious problem with the brake system. Reduce your speed and have your motorcycle inspected by your dealer as soon as possible.

- Indicator comes on or starts flashing while riding.
- Indicator does not come on when the ignition switch is in the ON position.
- Indicator does not go off at speeds above 6 mph (10 km/h).

If the ABS indicator stays on, your brakes will continue to work as a conventional system, but without the anti-locking function.

The ABS indicator may flash if you turn the rear wheel while your motorcycle is lifted off the ground. In this case, turn the ignition switch off and then on again. The ABS indicator will go off after your speed reaches 19 mph (30 km/h).

If the “-” Indicator is Blinking in the Gear Position Window While Riding

CTX700D only

If the “-” indicator is blinking while riding, you may have a serious problem with the Dual Clutch Transmission system.

Park your motorcycle in a safe place and have your motorcycle inspected by a dealer immediately.

There is a possibility for you to ride yourself to go to a dealer, if you follow the procedure below.

1. Turn the ignition switch to OFF.
2. Turn the ignition switch to ON and start the engine.

If you cannot start the engine:

Turn the ignition switch to OFF and move the motorcycle back and forth slightly (to disengage the gears).

Turn the ignition switch to ON again and start the engine.

If you still cannot start the engine:

Start the engine while applying the brake lever or pressing the brake pedal.

If you can shift from N to D mode:

When a gear position is shown in the gear position indicator, you can ride in that gear. Take your motorcycle to your dealer riding at a safe speed.

If you can't shift from N to D mode and the “-” indicator is blinking:

Damage is preventing you from riding. Have your motorcycle inspected by your dealer immediately.

Fuel Gauge Failure Indication

If the fuel system has an error, the fuel gauge indicators will be displayed as shown in the illustration.

If this occurs, see your dealer as soon as possible.

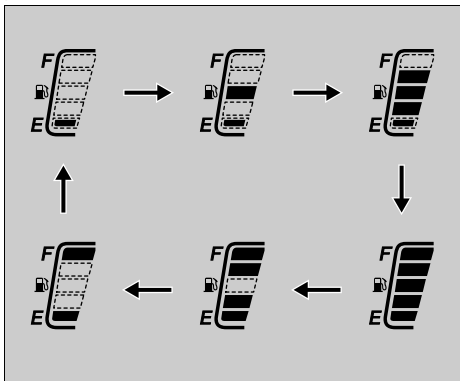

Tire Puncture

Repairing a puncture or removing a wheel requires special tools and technical expertise. We recommend you have this type of service performed by your dealer.

After an emergency repair, always have the tire inspected/replaced by your dealer.

Emergency Repair Using a Tire Repair Kit

If your tire has a minor puncture, you can make an emergency repair using a tubeless tire repair kit.

Follow the instructions provided with the emergency tire repair kit.

Riding your motorcycle with a temporary tire repair is very risky. Do not exceed 30 mph (50 km/h). Have the tire replaced by your dealer as soon as possible.

WARNING

Riding your motorcycle with a temporary tire repair can be risky. If the temporary repair fails, you can crash and be seriously injured or killed.

If you must ride with a temporary tire repair, ride slowly and carefully and do not exceed 30 mph (50 km/h) until the tire is replaced.

Removing Wheels

Follow these procedures if you need to remove a wheel in order to repair a puncture.

CTX700A/D only

When removing and installing the wheel, be careful not to damage the wheel speed sensor and pulser ring.

Front Wheel

Removal

1. Place on a firm, level surface.
2. Cover right side of the front wheel and brake caliper with protective tape or cloth.

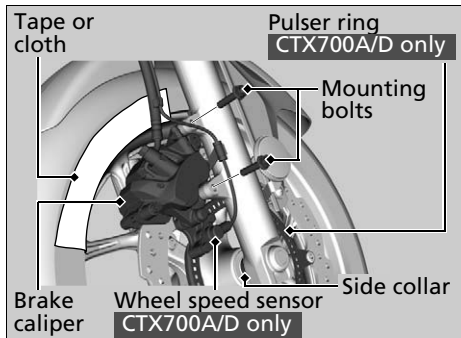

3. On the right side, remove the mounting bolts and remove the brake caliper.
 - Support the brake caliper assembly so that it doesn't hang from the brake hose. Do not twist the brake hose.
 - Avoid getting grease, oil, or dirt on the disc or pad surfaces.
 - Do not pull the brake lever while the brake caliper is removed.
 - Take care to prevent the brake caliper from scratching the wheel during removal.

4. Loosen the axle pinch bolt and front axle shaft.
5. Support your motorcycle securely and raise the front wheel off the ground using a maintenance stand or a hoist.
6. Remove the front axle shaft, front wheel and side collars.

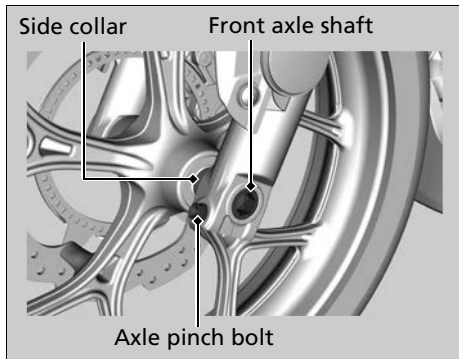

Installation

1. Attach the side collars to the wheel.
2. On the left side, place the wheel between the fork legs and insert the front axle shaft to the end, through the left fork leg and wheel hub.
3. Tighten the axle shaft.

Torque: 55 lbf·ft (74 N·m, 7.5 kgf·m).

Tire Puncture ► Removing Wheels

4. Install the brake caliper and tighten the mounting bolts.

Torque: 22 lbf·ft (30 N·m, 3.1 kgf·m).

- Take care to prevent the brake caliper from scratching the wheel during installation.
- Use new mounting bolts when installing the brake caliper.

NOTICE

When installing the brake caliper into position on the fork legs, carefully fit the brake disc between the pads to avoid scratching them.

5. Lower the front wheel on the ground.
6. Apply the brake lever and pump the fork several times.

7. Tighten the axle pinch bolt.

Torque: 16 lbf·ft (22 N·m, 2.2 kgf·m).

8. Raise the front wheel off the ground again, and check that the wheel rotates freely after you release the brake.
9. Uncover the protective tape or cloth.

If a torque wrench was not used for installation, see your dealer as soon as possible to verify proper assembly. Improper assembly may lead to loss of braking capacity.

Rear Wheel

Removal

1. Support your motorcycle securely and raise the rear wheel off the ground using a maintenance stand or a hoist.
2. **CTX700D only**
Release the parking brake.
3. **CTX700D only**
Remove the mounting bolts and remove the parking brake caliper.

CTX700D only

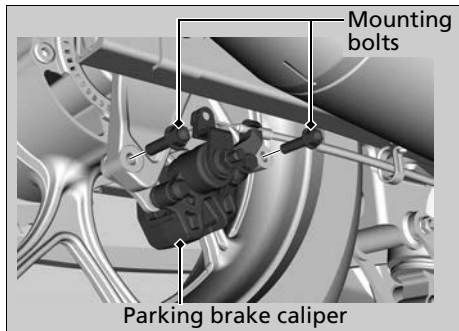

Tire Puncture ► Removing Wheels

- Loosen the rear axle nut, lock nuts and turn the adjusting nuts so the rear wheel can be moved all the way forward for maximum drive chain slack.
- Remove the drive chain from the rear wheel sprocket by pushing the rear wheel forward.
- Remove the rear axle nut, washer A and washer B.
- Remove the rear axle shaft, washer B, brake caliper bracket, rear wheel and side collars.
 - Support the brake caliper assembly so that it doesn't hang from the brake hose. Do not twist the brake hose.
 - Avoid getting grease, oil, or dirt on the disc to pad surfaces.
 - Do not push the brake pedal while the wheel is removed.
 - **CTX700D only**
Do not pull the parking brake lever while the wheel is removed.

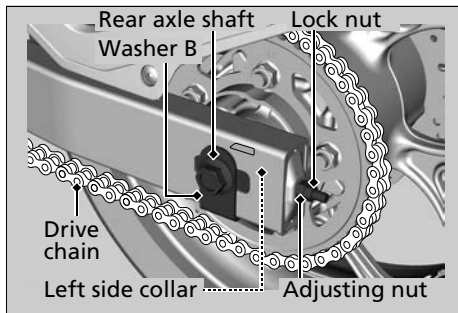
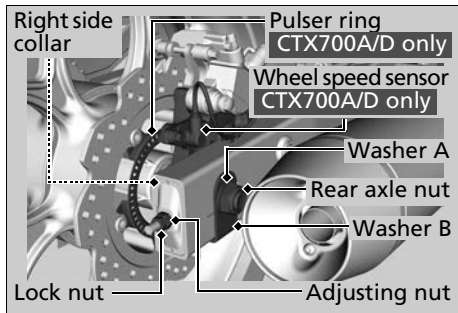

Installation

1. Attach the right and left side collars in their original locations on the wheel.
2. To install the rear wheel, reverse the removal procedure.
 - Take care to prevent the brake caliper from scratching the wheel during installation.

NOTICE

When installing the brake caliper into position, carefully fit the brake disc between the pads to avoid scratching them.

3. Make sure that the slot on the brake caliper bracket is positioned in the lug on the swingarm.

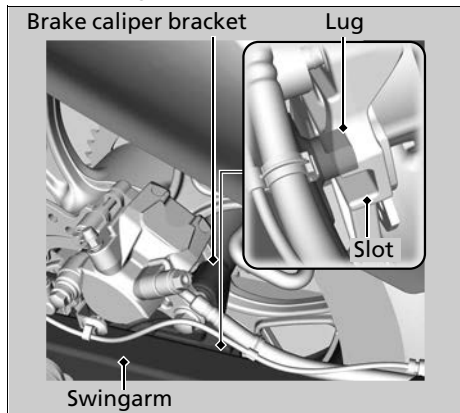

Tire Puncture ► Removing Wheels

4. Adjust the drive chain. ► P. 91
5. Remove the bolts and muffler end cover.
► P. 92
6. Install and tighten the rear axle nut.

Torque: 72 lbf·ft (98 N·m, 10.0 kgf·m).

7. Install the muffler end cover and tighten the bolts. ► P. 92
8. Tighten the drive chain adjusting nuts lightly, then hold the adjusting nuts and tighten the lock nuts.

Torque: 15 lbf·ft (21 N·m, 2.1 kgf·m).

9. After installing the wheel, apply the brake pedal several times, then recheck the wheel rotates freely. Recheck the wheel if the brake drags or if the wheel does not rotate freely.

10. CTX700D only

Install the parking brake caliper and tighten the mounting bolts.

Torque: 23 lbf·ft (31 N·m, 3.2 kgf·m).

- Take care to prevent the brake caliper from scratching the wheel during installation.
- Use new mounting bolts when installing the brake caliper.

NOTICE

When installing the brake caliper into position, carefully fit the brake disc between the pads to avoid scratching them.

If a torque wrench was not used for installation, see your dealer as soon as possible to verify proper assembly. Improper assembly may lead to loss of braking capacity.

Battery Goes Dead

Charge the battery using a motorcycle battery charger.

Remove the battery from the motorcycle before charging.

Do not use an automobile-type battery charger, as these can overheat a motorcycle battery and cause permanent damage.

If the battery does not recover after recharging, contact your dealer.

NOTICE

Jump starting using an automobile battery is not recommended, as this can damage your motorcycle's electrical system.

Burned-out Light Bulb

Follow the procedure below to replace a burned-out light bulb.

Turn the ignition switch to the OFF or LOCK position.

Allow the bulb to cool before replacing it. Do not use bulbs other than those specified.

Check the replacement bulb for correct operation before riding.

For the light bulb wattage, see "Specifications." ➤ P. 145

Headlight Bulb

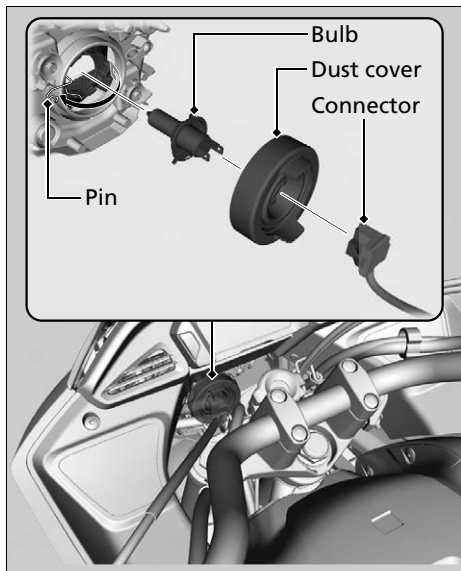

1. Pull off the connector without turning.
2. Remove the dust cover.
3. Press the pin down and pull out the bulb without turning it.
4. Install a new bulb and parts in the reverse order of removal.

Do not touch the glass surface with your fingers. If you touch the bulb with your bare hands, clean it with a cloth moistened with isopropyl (rubbing) alcohol.

Brake/Tail Light

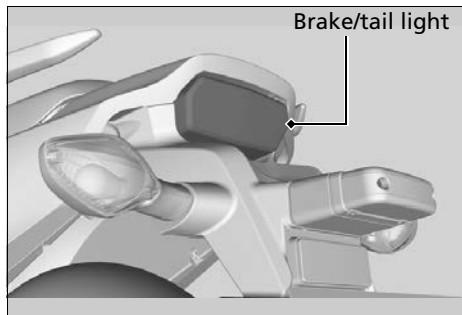

The brake and tail light uses several LEDs. If there is a LED which is not turned on, see your dealer for this service.

Front/Rear Turn Signal Bulb

1. Remove the screw and collar.
2. Remove the turn signal lens.
3. Slightly press the bulb and turn it counterclockwise.

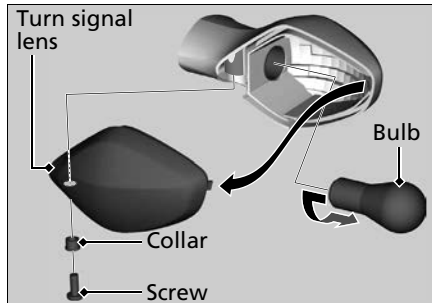

4. Install a new bulb and parts in the reverse order of removal.

License Plate Light

1. Remove the screws, license light cover and license light cover packing.
2. Pull out the bulb without turning.

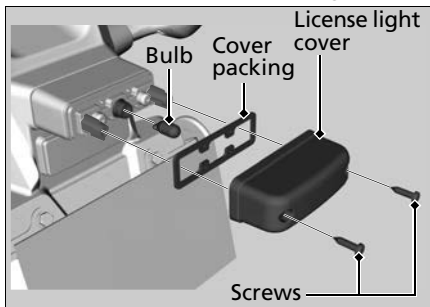

3. Install a new bulb and parts in the reverse order of removal.

Blown Fuse

Before handling fuses, see “Inspecting and Replacing Fuses.” ► P. 58

Fuse Box Fuses

1. Remove the seat. ► P. 73
2. Remove the fuse box cover.
3. Pull the fuses out with the fuse puller in the tool kit one by one and check for a blown fuse. Always replace a blown fuse with a spare fuse of the same rating.
► Spare fuses are provided on the back of the fuse box cover.
4. Reinstall the fuse box cover.
5. Reinstall the seat.

CTX700

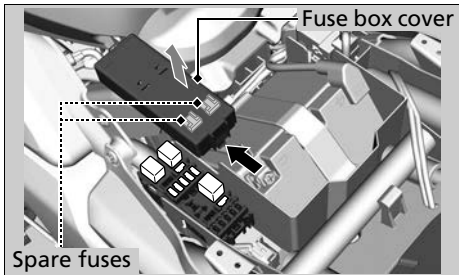

CTX700A

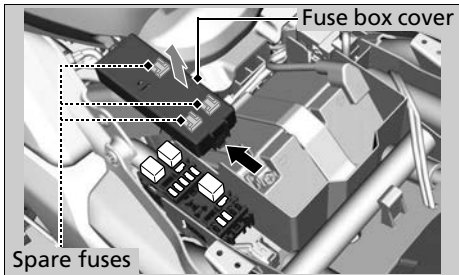

CTX700D

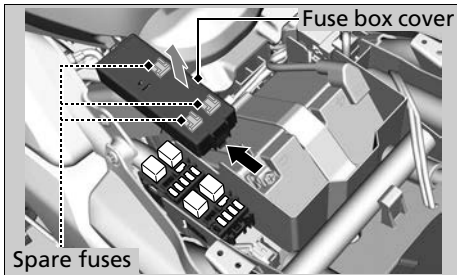

Main Fuse

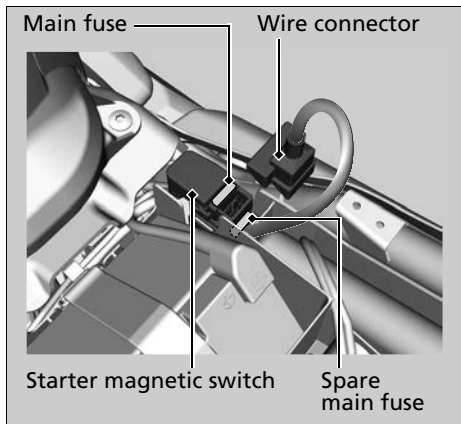

1. Remove the seat. ► P. 73
2. Disconnect the wire connector of the starter magnetic switch.

3. Pull the main fuse out with the fuse puller in the tool kit and check for a blown fuse. Always replace a blown fuse with a spare of the same rating.
► Spare main fuse is provided in the starter magnetic switch.
4. Install the parts in the reverse order of removal.

NOTICE

If a fuse fails repeatedly, you likely have an electrical problem. Have your motorcycle inspected by your dealer.

Information

Keys	P. 122
Instruments, Controls, & Other Features ...	P. 123
Caring for Your Motorcycle	P. 124
Storing Your Motorcycle	P. 127
Transporting Your Motorcycle	P. 128
You & the Environment	P. 128
Vehicle Identification Number	P. 129
Emission Control Systems	P. 131
Catalytic Converter	P. 135
Oxygenated Fuels	P. 136
Authorized Manuals	P. 137
Warranty Coverage and Service	P. 139

Honda Contacts	P. 140
USA Reporting Safety Defects	P. 142

Keys

Ignition key

Be sure to record the key number provided with the original keys. Store the spare key and recorded key number in a safe location.

To make a duplicate, take the spare key or the key number to your dealer.

If you lose all keys and the key number, the ignition switch assembly will probably have to be removed by your dealer to determine the key number.

A metal key holder may cause damage to the area surrounding the ignition switch.

Instruments, Controls, & Other Features

Ignition Switch

Leaving the ignition switch ON with the engine stopped will drain the battery. Do not turn the key while riding.

Engine Stop Switch

Do not use the engine stop switch except in an emergency. Doing so when riding will cause the engine to suddenly turn off, making riding unsafe. If you stop the engine using the engine stop switch, turn the ignition switch off. Failing to do so will drain the battery.

Odometer

The display locks at 999,999 when the read-out exceeds 999,999.

Tripmeter

The tripmeter A and B returns to 0.0 when the read-out exceeds 999.9.

Document Bag

The owner's manual, registration, and insurance information can be stored in the plastic document bag located underside of the seat. ➤ P. 45

Ignition Cut-off System

A banking (lean angle) sensor automatically stops the engine and fuel pump if the motorcycle falls over. To reset the sensor, you must turn the ignition switch to OFF and back to the ON position before the engine can be restarted.

Caring for Your Motorcycle

Frequent cleaning and polishing is important to ensure the life of your Honda. A clean motorcycle makes it easier to spot potential problems.

In particular, seawater and salts used to prevent ice on roads promote the formation of corrosion. Always wash your motorcycle thoroughly after riding on coastal or treated roads.

Washing

Allow the engine, muffler, brakes, and other high-temperature parts to cool before washing.

1. Rinse your motorcycle thoroughly using a garden hose to remove loose dirt.
2. If necessary, use a sponge or a soft towel with mild cleaner to remove road grime.
 - ▶ Clean the windscreen, headlight lens, panels, and other plastic components with extra care to avoid scratching them.

Avoid directing water into the air cleaner, muffler, and electrical parts.

3. Thoroughly rinse your motorcycle with plenty of clean water and dry with a soft, clean cloth.
4. After the motorcycle dries, lubricate any moving parts.
 - ▶ Make sure that no lubricant spills onto the brakes or tires. Brake discs, pads, drum or shoes contaminated with oil will suffer greatly reduced braking effectiveness and can lead to a crash.
5. Lubricate the drive chain immediately after washing and drying the motorcycle.
6. Apply a coat of wax to prevent corrosion.
 - ▶ Avoid products that contain harsh detergents or chemical solvents. These can damage the metal, paint, and plastic on your motorcycle.
 - ▶ Keep the wax clear of the tires and brakes.
 - ▶ If your motorcycle has any matte painted parts, do not apply a coat of wax to the matte painted surface.

Washing Precautions

Follow these guidelines when washing:

- Do not use high-pressure washers:
 - ▶ High-pressure water cleaners can damage moving parts and electrical parts, rendering them inoperable.
 - ▶ Water in the air intake can be drawn into the throttle body and/or enter the air cleaner.
- Do not direct water at the muffler:
 - ▶ Water in the muffler can prevent starting and causes rust in the muffler.
- Dry the brakes:
 - ▶ Water adversely affects braking effectiveness. After washing, apply the brakes intermittently at low speed to help dry them.
- Do not direct water under the seat:
 - ▶ Water in the under seat compartment can damage your documents and other belongings.

- Do not direct water at the air cleaner:
 - ▶ Water in the air cleaner can prevent the engine from starting.
- Do not direct water near the headlight:
 - ▶ Any condensation inside the headlight should dissipate after a few minutes of running the engine.
- Do not use wax or polishing compounds on matte painted surface:
 - ▶ Use a soft cloth or sponge, plenty of water, and a mild detergent to clean matte painted surfaces. Dry with a soft clean cloth.

Aluminum Components

Aluminum will corrode from contact with dirt, mud, or road salt. Clean aluminum parts regularly and follow these guidelines to avoid scratches:

- Do not use stiff brushes, steel wool, or cleaners containing abrasives.
- Avoid riding over or scraping against curbs.

Caring for Your Motorcycle

Panels

Follow these guidelines to prevent scratches and blemishes:

- Wash gently using a soft sponge and plenty of water.
- To remove stubborn stains, use diluted detergent and rinse thoroughly with plenty of water.
- Avoid getting gasoline, brake fluid, or detergents on the instruments, panels, or headlight.

Windscreen

Using plenty of water, clean the windscreen with a soft cloth or sponge. (Avoid using detergents or any kind of chemical cleaner on the windscreen.) Dry with a soft, clean cloth.

NOTICE

To avoid possible scratching or other damage, use only water and a soft cloth or sponge to clean the windscreen.

For a dirtier windscreen, use a diluted neutral detergent with a sponge and plenty of water.

Make sure to wash off all the detergent. (Detergent residue may cause windscreen cracks.)

Replace the windscreen if scratches cannot be removed and they obstruct clear vision.

Take care to keep battery electrolyte, brake fluid, or other chemical solvents off the windscreen and screen garnish. They will damage the plastic.

Exhaust Pipe and Muffler

The exhaust pipe and muffler are stainless steel but may become stained by mud or dust. To remove mud or dust, use a wet sponge and a liquid kitchen abrasive, then rinse well with clean water. Dry with chamois or a soft towel. If necessary, remove heat stains by using a commercially available fine texture compound. Then rinse by the same manner as removing mud or dust.

NOTICE

Even though the exhaust is made of stainless steel, it can become stained. Remove all marks and blemishes as soon as they are noticed.

Storing Your Motorcycle

If you store your motorcycle outdoors, you should consider using a full-body motorcycle cover.

If you won't be riding for an extended period, follow these guidelines:

- Wash your motorcycle and wax all painted surfaces (except matte painted surfaces). Coat chrome pieces with rust-inhibiting oil.
- Lubricate the drive chain. ➤ P. 61
- Place your motorcycle on a maintenance stand and position a block so that both tires are off the ground.
- After rain, remove the body cover and allow the motorcycle to dry.
- Remove the battery (➤ P. 68) to prevent discharge. Charge the battery in a shaded, well-ventilated area.
 - ▶ If you leave the battery in place, disconnect the negative ⊖ terminal to prevent discharge.

Transporting Your Motorcycle

After removing your motorcycle from storage, inspect all maintenance items required by the Maintenance Schedule.

USA For more information about storage, refer to the Honda Winter Storage Guide, available from your dealer.

Canada For more information about storage, visit our website at www.honda.ca and look up “Storage Tips” under the Parts & Service tab.

Transporting Your Motorcycle

If your motorcycle needs to be transported, it should be carried on a motorcycle trailer or a flatbed truck or trailer that has a loading ramp or lifting platform, and motorcycle tie-down straps. Never try to tow your motorcycle with a wheel or wheels on the ground.

NOTICE

Towing your motorcycle can cause serious damage to the transmission.

You & the Environment

Owning and riding a motorcycle can be enjoyable, but you must do your part to protect the environment.

Choose Sensible Cleaners

Use a biodegradable detergent when you wash your motorcycle. Avoid aerosol spray cleaners that contain chlorofluorocarbons (CFCs) which damage the atmosphere's protective ozone layer.

Recycle Wastes

Put oil and other toxic wastes in approved containers and take them to a recycling center. Call your local or state office of public works or environmental services to find a recycling center in your area, and to get instructions on how to dispose of non-recyclable wastes. Do not place used engine oil in the trash, or pour it down a drain or on the ground. Used oil, gasoline, coolant, and cleaning solvents contain poisons that can hurt refuse workers and contaminate drinking water, lakes, rivers, and oceans.

Vehicle Identification Number

The VIN and engine serial number uniquely identify your motorcycle and are required in order to register your motorcycle. They may also be required when ordering replacement parts. The VIN is stamped on the right side of the steering head and also appears on the Safety Certification Label attached to the left side of the frame.

The engine number is stamped on the right rear side of the crankcase.

You should record these numbers and keep them in a safe place.

Vehicle Identification Number

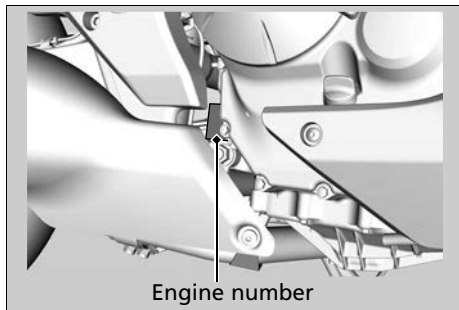
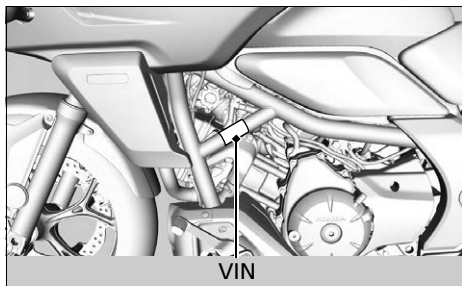
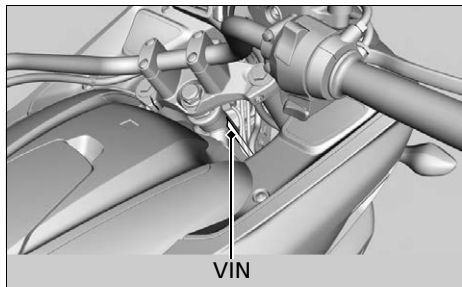

Emission Control Systems

Your motorcycle engine emits combustion by-products, including carbon monoxide (CO), oxides of nitrogen (NO_x), and hydrocarbons (HC). Gasoline evaporation also emits hydrocarbons. Controlling the production of NO_x, CO, and HC is important for the environment.

Exhaust Emission Requirements

The U.S. Environmental Protection Agency (EPA), the California Air Resources Board (CARB), and Environment Canada (EC) require that your motorcycle comply with applicable exhaust, crankcase, and fuel permeation emission standards during its useful life, when operated and maintained according to the instructions provided.

CARB also requires that your motorcycle comply with applicable evaporative emission requirements during its useful life, when

operated and maintained according to the instructions provided.

Compliance with the terms of the Distributor's Warranties for Honda Motorcycle Emission Control Systems is necessary in order to maintain a valid emissions system warranty (USA only).

The Vehicle Emission Control Information label is attached to the left side of the swingarm.

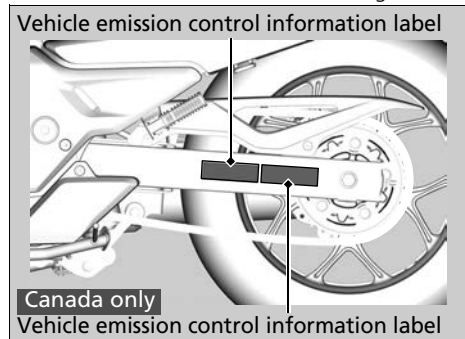

Emission Control Systems

Noise Emission Requirements

The EPA requires that motorcycles built after January 1, 1983 comply with applicable noise emission standards for one year or 3,730 miles (6,000 km) after the time of purchase when operated and maintained according to the instructions provided.

Exhaust Emission Control System

The exhaust emission control system includes the following components that should not need adjustment, although periodic inspection by your dealer is recommended.

PGM-FI System

The PGM-FI (programmed fuel injection) system uses sequential multiport fuel injection, and is comprised of air intake, engine control, fuel control, and exhaust control subsystems. The engine control module (ECM) uses sensors to determine how much air enters the engine,

and then controls how much fuel to inject.

Ignition Timing Control System

The ignition timing control system adjusts the ignition timing to reduce the amount of HC, CO, and NOx produced.

Catalytic Converters

The exhaust system contains one or more catalytic converters. Catalytic converters use a catalyst to convert most of the harmful exhaust gas compounds into harmless compounds.

Evaporative Emission Control System

50 STATE (meets California)

An evaporative emissions control system uses a canister filled with charcoal to adsorb fuel vapor from the fuel tank while the engine is off. The vapor is drawn into the engine and burned while riding.

Crankcase Emissions Control System

The engine is equipped with a closed crankcase system to prevent discharging crankcase emissions into the atmosphere. Blow-by gas is returned to the combustion chamber through the air cleaner and the intake manifold.

Fuel Permeation Emission Control

The fuel tank, fuel hoses, and fuel vapor charge hoses use fuel permeation control technologies to prevent fuel vapor emissions. Tampering with these components to reduce or defeat the effectiveness of the fuel permeation technologies is prohibited.

Noise Emission Control System

■ TAMPERING WITH THE NOISE CONTROL SYSTEM IS PROHIBITED:

U. S. federal law prohibits, and Canadian provincial laws may prohibit, the following acts or the causing thereof: (1) The removal or rendering inoperative by any person, other than for purposes of maintenance, repair or replacement, of any device or element of design incorporated into any new vehicle for the purpose of noise control prior to its sale or delivery to the ultimate purchaser or while it is in use; or (2) the use of the vehicle after such device or element of design has been removed or rendered inoperative by any person.

AMONG THOSE ACTS PRESUMED TO CONSTITUTE TAMPERING ARE THE FOLLOWING ACTS:

- Removal of, or puncturing the muffler, baffles, header pipes or any other component which conducts exhaust gases.
- Removal of, or puncturing of any part of the intake system.
- Lack of proper maintenance.
- Removing or disabling any emissions compliance component, or replacing any compliance component with a non-compliant component.

Problems Affecting Motorcycle Exhaust Emissions

Have your motorcycle inspected and repaired by your dealer if you experience any of the following symptoms:

- Hard starting or stalling after starting
- Rough idling
- Misfiring or backfiring during acceleration
- Poor engine performance and poor fuel economy

Catalytic Converter

This motorcycle is equipped with a three-way catalytic converter. The catalytic converter contains precious metals that serve as catalysts in high temperature chemical reactions that convert hydrocarbons (HC), carbon monoxide (CO), and oxides of nitrogen (NOx) in the exhaust gasses into safe compounds.

A defective catalytic converter contributes to air pollution and can impair your engine's performance. A replacement unit must be an original Honda part or equivalent.

Follow these guidelines to protect your motorcycle's catalytic converter.

- Always use unleaded gasoline. Leaded gasoline will damage the catalytic converter.
- Keep the engine in good running condition. A poorly running engine can cause the catalytic converter to overheat causing damage to the converter or the motorcycle.
- If your engine is misfiring, backfiring, stalling, or otherwise not running properly, stop riding and turn off the engine. Have your motorcycle serviced as soon as possible.

Oxygenated Fuels

Some conventional fuels blended with alcohol or an ether compound are available in some locales to help reduce emissions to meet clean air standards. These gasolines are collectively referred to as oxygenated fuels. If you plan to use oxygenated fuel, check that it is unleaded and meets the minimum octane rating and blend requirement.

The following fuel blends are EPA-approved and have been approved for use in your motorcycle:

- Ethanol (ethyl alcohol) up to 10% by volume.
 - ▶ Gasoline containing ethanol may be marketed under the name Gasohol.
- Methanol (methyl alcohol) up to 5% by volume that contain cosolvents and corrosion inhibitors to protect the fuel system. Never use a blend containing more than 5%.

If you accidentally fill your fuel tank with an oxygenated fuel containing higher percentages, you may experience performance problems. To resolve the problem, have your dealer drain the fuel tank and replace with the correct fuel. Fuel system or performance problems resulting from the use of an oxygenated fuel containing higher percentages are not covered by your warranty.

NOTICE

Improper use of oxygenated fuels can damage metal, rubber, and plastic parts of your fuel system. Oxygenated fuel can also damage paint. Damage caused by spilled fuel is not covered by warranty.

If you notice any undesirable operating symptoms or performance problems, try a different brand of gasoline.

Authorized Manuals

The Service Manual used by your authorized dealer is available from your Honda dealer or Helm, Inc.

(USA only, Canada: See your dealer to order authorized manuals.)

Also available, but not necessary to service your model, is the Honda Common Service Manual, which explains basic service information for various systems on Honda motorcycles, scooters, and ATV.

The Winter Storage Guide in conjunction with the Owner's Manual and Service Manual can help you prepare your Honda motorcycle, scooter, ATV, and SxS for winter storage.

These Honda manuals are written for the professional technician. However, if you possess the proper tools, observe the safety standards, and are mechanically capable, you should find them easy to use.

Special Honda tools are necessary for some procedures.

Publication Item No.	Description
61MJF02	2016 CTX700/A/D/N/NA/ND Service Manual
61CSM00	Common Service Manual
S9507	Winter Storage Guide
31MJF820	2016 CTX700/A/D Owner's Manual

Authorized Manuals

Order On-Line: www.helminc.com

Order Toll Free: 1-888-CYCLE93

(1-888-292-5393)

(NOTE: For Credit Card Orders Only)

Monday - Friday 8:00 AM - 6:00 PM EST

Warranty Coverage and Service

Coverage

Your new Honda is covered by the following warranties:

- Motorcycle Limited Warranty
- Emission Control System Warranty
- Noise Control Warranty (USA only)

The responsibilities, restrictions, and exclusions that apply to these warranties are explained in the Warranties Booklet given to you by your Honda dealer at the time of purchase. Always keep your Honda owner's card with your Warranties Booklet.

Canada Please refer to the Warranty Booklet posted on our website at www.honda.ca.

It is important to realize that your warranty applies only to defects in material or workmanship of your Honda. Your warranty coverage does not apply to the normal wear and deterioration associated with use of the motorcycle.

Your warranty coverage is not voided if you perform your own maintenance. However, failures that occur due directly to improper maintenance are not covered by these warranties.

You can extend almost all of your warranty coverage through the Honda Protection Plan (USA only). For more information, see your Honda dealer.

Honda Contacts

Service

Please remember that maintenance recommended in the Maintenance Schedule is not included in your warranty coverage.

If you believe you have a problem with your motorcycle, call the service department of your Honda dealer. Make an appointment for an inspection and diagnosis. You will be asked to authorize that inspection, and your dealer will return the results of the inspection. If a problem exists and is covered under warranty, your dealer will perform the warranty repairs. If you have any questions about your warranty coverage or the nature of the repair, talk to the Service Manager of your Honda dealer.

If a misunderstanding occurs and you aren't satisfied with your dealer's handling of the situation, we suggest you discuss your problem with the appropriate member of the dealership's management team. If you are still not satisfied, contact the owner of the dealership or their designated representative.

Honda Contacts

American Honda Motor Co., Inc.

If you wish to contact Honda directly to comment on your experiences with your motorcycle or with your dealer, please send your comments to the following address:

Motorcycle Division,
American Honda Motor Co., Inc.,
P.O. Box 2200, Torrance,
CA 90509-2200
Mailstop: 100-4C-7B,
Telephone: (866) 784-1870.

Canada

Honda Canada Inc.
Customer Relations Department,
180 Honda Boulevard
Markham, Ontario
L6C 0H9
Telephone: (888) 946-6329
Fax: (877) 939-0909
E-mail: honda_cr@ch.honda.com

Please include the following information in your letter:

- Name, address, and telephone number
- Product model, year, and VIN
- Date of purchase
- Dealer name and address

We will likely ask your Honda dealer to respond, or possibly acknowledge your comments directly.

Your Honda Dealer

The service department of your Honda dealer offers trained personnel to perform regular maintenance and most repairs. It has the latest available service information from Honda and also handles warranty inspections and repairs.

The parts department offers Honda Genuine Parts, Pro Honda products, Honda Genuine Accessories (USA only), and Honda accessories and products (Canada only) that provide the

same quality that went into your motorcycle.

The sales department offers the Honda Protection Plan to extend almost all of your warranty coverage (USA only).

Your Honda dealer can also supply information about, riding events, and information about safety training available in your local area, and the Honda Rider's Club of America (USA only).

Honda Rider's Club of America (HRCA)

The Honda Rider's Club of America (HRCA) sponsors local riding chapters at Authorized Honda Dealerships across the country. You can log on to the HRCA Clubhouse website for more information at www.hrca.honda.com.

USA Reporting Safety Defects

If you believe that your vehicle has a defect which could cause a crash or could cause injury or death, you should immediately inform the National Highway Traffic Safety Administration (NHTSA) in addition to notifying American Honda Motor Co., Inc.

If NHTSA receives similar complaints, it may open an investigation, and if it finds that a safety defect exists in a group of vehicles, it may order a recall and remedy campaign. However, NHTSA cannot become involved in individual problems between you, your dealer, or American Honda Motor Co., Inc.

To contact NHTSA, you may call the Vehicle Safety Hotline toll-free at: 1-888-327-4236

(TTY: 1-800-424-9153); go to <http://www.safercar.gov>;

or write to:

Administrator, NHTSA,
1200 New Jersey Avenue, SE.,
Washington, DC 20590.

You can also obtain other information about motor vehicle safety from:

<http://www.safercar.gov>.

Specifications

■ Main Components

Type	RC69	
Overall length	89.2 in (2,265 mm)	
Overall width	CTX700/A	33.7 in (855 mm)
	CTX700D	33.1 in (840 mm)
Overall height	45.9 in (1,165 mm)	
Wheelbase	60.2 in (1,530 mm)	
Minimum ground clearance	5.1 in (130 mm)	
Caster angle	27° 42'	
Trail	4.5 in (114 mm)	
Curb weight	CTX700	494 lb (224 kg)*2
		496 lb (225 kg)*3
	CTX700A	498 lb (226 kg)
	CTX700D	516 lb (234 kg)*2 518 lb (235 kg)*3
Maximum weight capacity*1	388 lb (176 kg)	
Passenger capacity	Rider and 1 passenger	
Minimum turning radius	9.9 ft (3.0 m)	

*1 Including rider, passenger, all luggage, and accessories

*2 49 STATE

*3 50 STATE (meets California)

Displacement	40.9 cu-in (670 cm ³)	
Bore x stroke	2.9 x 3.1 in (73 x 80 mm)	
Compression ratio	10.7:1	
Fuel	Unleaded gasoline	
	Recommended fuel octane number: Pump Octane Number (PON) 86 or higher.	
Tank capacity	3.28 US gal (12.4 liters)	
Battery	YTZ12S 12V-11.0Ah (10 HR)	
Gear ratios	CTX700/A	
	1st	2.812
	2nd	1.894
	3rd	1.454
	4th	1.200
	5th	1.033
	6th	0.837
	CTX700D	
	1st	2.666
	2nd	1.904
	3rd	1.454
	4th	1.200
5th	1.033	
6th	0.837	
Reduction ratios (primary / final)	CTX700/A	1.731 / 2.687
	CTX700D	1.921 / 2.437

Specifications

■ Service Data

Tire size	Front	120/70ZR17M/C (58W)
	Rear	160/60ZR17M/C (69W)
Tire type	Radial, tubeless	
Recommended Tires	Front	BRIDGESTONE BT023F G METZELER ROADTEC Z8 INTERACT E
	Rear	BRIDGESTONE BT023R G METZELER ROADTEC Z8 INTERACT
Tire air pressure	Front	36 psi (250 kPa, 2.50 kgf/cm ²) [With less than 200 lb (90 kg) of added weight]
	Rear	36 psi (250 kPa, 2.50 kgf/cm ²) [With more than 200 lb (90 kg) of added weight or when carrying a passenger] 42 psi (290 kPa, 2.90 kgf/cm ²)
Minimum tread depth	Front	0.06 in (1.5 mm)
	Rear	0.08 in (2.0 mm)
Spark plugs	(standard)	IFR6G-11K (NGK)
Spark plug gap	(non-adjustable)	0.039 to 0.043 in (1.00 to 1.10 mm)
Idle speed	1,200 ± 100 rpm	

Recommended engine oil

API Service Classification SG or higher except oils labeled as energy conserving or resource conserving on the circular API service label, SAE 10W-30, JASO T 903 standard MA, Pro Honda GN4 4-stroke oil (USA & Canada) or Honda 4-stroke oil, or an equivalent motorcycle oil

CTX700/A

After draining 3.3 US qt (3.1 liters)

After draining & engine oil filter change 3.6 US qt (3.4 liters)

After disassembly 3.9 US qt (3.7 liters)

CTX700D

After draining 3.4 US qt (3.2 liters)

After draining & engine oil filter change 3.6 US qt (3.4 liters)

After draining, engine & clutch oil filter change 3.6 US qt (3.4 liters)

After disassembly 4.3 US qt (4.1 liters)

Engine oil capacity

Recommended brake fluid

Honda DOT 4 Brake Fluid

Cooling system capacity

1.79 US qt (1.69 liters)

Recommended coolant	Pro Honda HP Coolant	
Recommended drive chain lubricant	Pro Honda HP Chain Lube or equivalent	
Drive chain slack	1 to 1 3/8 in (25 to 35 mm)	
Standard drive chain	DID 520V0 or RK 520KHO	
	CTX700/A	No. of links 114
	CTX700D	No. of links 112
Standard sprocket sizes	Front sprocket 16T	
	Rear wheel sprocket	
	CTX700/A	43T
	CTX700D	39T

■ Bulbs

Headlight	12V-60/55W	
Brake/Tail light	LED	
Front turn signal lights	12V-21/5W × 2	
Rear turn signal lights	12V-21W × 2	
License plate light	12V-5W	

■ Fuses

Main fuse	30A	
Other fuses	CTX700	15A, 7.5A
	CTX700A/D	30A, 15A, 7.5A

■ Torque Specifications

Engine oil drain bolt	22 lbf-ft (30 N·m, 3.1 kgf·m)
Engine oil filter	19 lbf-ft (26 N·m, 2.7 kgf·m)
Front wheel axle shaft	55 lbf-ft (74 N·m, 7.5 kgf·m)
Front wheel brake caliper mounting bolts	22 lbf-ft (30 N·m, 3.1 kgf·m)
Front wheel axle pinch bolt	16 lbf-ft (22 N·m, 2.2 kgf·m)
Rear wheel axle nut	72 lbf-ft (98 N·m, 10.0 kgf·m)
Muffler end cover bolts	7 lbf-ft (10 N·m, 1.0 kgf·m)
Drive chain adjusting lock nuts	15 lbf-ft (21 N·m, 2.1 kgf·m)
Parking brake caliper mounting bolts	23 lbf-ft (31 N·m, 3.2 kgf·m)

Information Record

VIN	
Engine No.	
Color Label & Code	
Owner's Name	
Address	
City/State	
Phone	
Dealer's Name	
Address	
City/State	
Phone	
Service Manager	

- A**
ABS (Anti-lock Brake System)
 Indicator 27, 104
Accessories..... 14
Anti-lock Brake System (ABS)..... 11
Authorized Manuals 137
- B**
Battery 56, 68
Brake Light Switch 88
Brakes
 Fluid..... 60, 85
 Pad Wear 86
Braking 10
Bulb
 Brake/Tail Light 117
 Front/Rear Turn Signal..... 117
 Headlight 116
 License Plate Light..... 118
- C**
Caring for Your Motorcycle..... 124
Center Lower Fairing 69
Clutch Oil Filter..... 81
Clutch System 94
Color Label..... 55
Coolant 62, 83
Crankcase Breather 98
- D**
D Mode 37, 39, 40
Digital Clock Adjustment..... 25
Drive Chain 60, 90
Dual Clutch Transmission..... 37
- E**
Electrical Trouble..... 115
Emission Control Systems..... 131

Engine

Number.....	129
Oil.....	59, 77
Oil Filter.....	79
Overheats.....	102
Starting.....	32
Stop Switch.....	28, 31, 123
Stopping.....	123
Environment	128
Equipment	
Owner's Manual.....	45
Tool Kit.....	45
F	
Flooded Engine	32
Fuel	
Gauge.....	21, 22
Oxygenated.....	136
Recommended.....	42
Remaining.....	21, 22
Tank Capacity.....	42
Fuses	58, 118

G

Gasohol	136
Gasoline	42
Gear Position Indicator	23

H

Hazard Switch	28, 30
Headlight Aim	99
Headlight Dimmer Switch	28, 30
Helmet Holder	46
High Beam Indicator	27
High Coolant Temperature	
Indicator.....	26, 102
Honda Contacts	140
Horn Button	28, 31

I**Ignition Cut-off System**

Banking Sensor.....	123
Side Stand.....	89
Ignition Key	122
Ignition Switch	29, 31, 123
Indicators	26

Information Record	146
Instruments	20

L

Labels	7
Load Limits	15
Loading Guidelines	15
Low Oil Pressure Indicator.....	26, 103

M

Maintenance

Fundamentals	53
Importance	48
Safety	49
Schedule	50
Maximum Weight Limit.....	15
Modifications	14
MT Mode.....	37, 39, 40

N

N-D Switch.....	31, 40
Neutral Indicator.....	27

O

Odometer	21, 22, 123
Oil	
Engine.....	59, 77
Overheating.....	102
Oxygenated Fuels.....	136

P

Parking.....	12
Parking Brake	87
Parking Brake Indicator	27
Parking Brake Lever	30
Parts Location	16
PGM-FI (Programmed Fuel Injection)	
malfunction indicator lamp	
(MIL)	26, 103
Protective Apparel	9

R

Recommended

Coolant	62
Fuel	42
Oil	59

- Refueling 42
- Removal
 - Battery 68
 - Center Lower Fairing 69
 - Clip 70
 - Right Under Fairing..... 71
 - Right Under Fairing Lid 72
 - Seat..... 73
- Repair Kit..... 107
- Reporting Safety Defects..... 142
- Riding Precautions 10
- Right Under Fairing..... 71
- Right Under Fairing Lid..... 72
- S**
- S Mode 37, 39, 40
- Safety Labels..... 7
- Safety Precautions..... 9
- Seat 73
- Shelter Pocket..... 44
- Shifting Gears 35
- Side Stand 89
- Side Stand Ignition Cut-off System 89
- Spark Plugs..... 74
- Specifications 143
- Speedometer..... 21, 22
- Start Button 28, 31
- Starting the Engine 32
- Steering Lock 29
- Stopping Engine 123
- Storage
 - Equipment 44
 - Helmet..... 46
 - Owner's Manual 45, 123
 - Shelter Pocket..... 44
 - Tool Kit..... 45
- Storing Your Motorcycle 127
- Switches..... 28
- T**
- Tachometer 21, 22
- Throttle 97
- Tires**
 - Air Pressure..... 63
 - Puncture 107
 - Replacing..... 63, 107

Tool Kit.....	45
Transporting Your Motorcycle.....	128
Tripmeter.....	21, 22, 123
Troubleshooting	100
Turn Signal Indicators.....	27

V

Vehicle Identification Number.....	129
------------------------------------	-----

W

Warning Indicators On or Flashing.....	103
Warranty Coverage and Service.....	139
Washing Your Motorcycle.....	124
Weight Limit	15, 143
Wheels	
Front Removal.....	108
Rear Removal.....	111