

# INDOOR PACKAGED EQUIPMENT

INSTALLATION, OPERATION & MAINTENANCE

NEW RELEASE

Form 145.18-IOM3 (218)

## CABINET MODEL VSB/VSM/VSS/VST09-36 AND CHASSIS MODEL VSCS09-36 SINGLE RISER HI-RISE WATER SOURCE HEAT PUMP



**R-410A**

LD23534



Issue Date:  
February 28, 2018



# IMPORTANT!

## READ BEFORE PROCEEDING!

### GENERAL SAFETY GUIDELINES

This equipment is a relatively complicated apparatus. During rigging, installation, operation, maintenance, or service, individuals may be exposed to certain components or conditions including, but not limited to: heavy objects, refrigerants, materials under pressure, rotating components, and both high and low voltage. Each of these items has the potential, if misused or handled improperly, to cause bodily injury or death. It is the obligation and responsibility of rigging, installation, and operating/service personnel to identify and recognize these inherent hazards, protect themselves, and proceed safely in completing their tasks. Failure to comply with any of these requirements could result in serious damage to the equipment and the property in

which it is situated, as well as severe personal injury or death to themselves and others at the site.

This document is intended for use by owner-authorized rigging, installation, and operating/service personnel. It is expected that these individuals possess independent training that will enable them to perform their assigned tasks properly and safely. It is essential that, prior to performing any task on this equipment, this individual shall have read and understood the on-product labels, this document and any referenced materials. This individual shall also be familiar with and comply with all applicable industry and governmental standards and regulations pertaining to the task in question.

---

### SAFETY SYMBOLS

The following symbols are used in this document to alert the reader to specific situations:



*Indicates a possible hazardous situation which will result in death or serious injury if proper care is not taken.*



*Identifies a hazard which could lead to damage to the machine, damage to other equipment and/or environmental pollution if proper care is not taken or instructions and are not followed.*



*Indicates a potentially hazardous situation which will result in possible injuries or damage to equipment if proper care is not taken.*

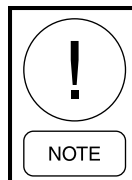

*Highlights additional information useful to the technician in completing the work being performed properly.*



*External wiring, unless specified as an optional connection in the manufacturer's product line, is not to be connected inside the control cabinet. Devices such as relays, switches, transducers and controls and any external wiring must not be installed inside the micro panel. All wiring must be in accordance with the manufacturer's published specifications and must be performed only by a qualified electrician. The manufacturer will NOT be responsible for damage/problems resulting from improper connections to the controls or application of improper control signals. Failure to follow this warning will void the manufacturer's warranty and cause serious damage to property or personal injury.*

## CHANGEABILITY OF THIS DOCUMENT

In complying with the manufacturer's policy for continuous product improvement, the information contained in this document is subject to change without notice. There is no commitment to update or provide current information automatically to the manual or product owner. Updated manuals, if applicable, can be obtained by contacting the nearest service office.

It is the responsibility of rigging, lifting, and operating/service personnel to verify the applicability of these documents to the equipment. If there is any question regarding the applicability of these documents, rigging,

lifting, and operating/service personnel should verify whether the equipment has been modified and if current literature is available from the owner of the equipment prior to performing any work on the equipment.

### CHANGE BARS

Revisions made to this document are indicated with a line along the left or right hand column in the area the revision was made. These revisions are to technical information and any other changes in spelling, grammar or formatting are not included.

---

## ASSOCIATED LITERATURE

MANUAL DESCRIPTION	FORM NUMBER
Vertical Stacked Heat Pump Start-Up and Performance Checklist	145.18-CL1

# CABINET NOMENCLATURE

1, 2, 3 4, 5 6 7 8 9 10 11 12, 13 14 15 16

VSB 12 M 1 D E A 2 2T 4 0 A

PRODUCT CATEGORY
VSB = Vertical Stacked Heat Pump - Standard Cabinet Assembly
VSM = Vertical Stacked Heat Pump - Master Cabinet Assembly
VSS = Vertical Stacked Heat Pump - Satellite Cabinet Assembly

UNIT CAPACITY
09 = 3/4 TON      24 = 2 TON
12 = 1 TON      30 = 2-1/2 TON
15 = 1-1/4 TON      36 = 3 TON
18 = 1-1/2 TON

CONTROL OPTIONS				
	Thermostat Location			
	Remote	Whip	Surface	ADA Door
2-Speed Unit-Mounted Switch	M	W	P	A
3-Speed Thermostat Control	3	4	5	7

VOLTAGE
1 = 208/230-60-1
6 = 265-60-1

ELECTRICAL CONNECTION
0 = None (Terminal Block)
D = Non-Fused Disconnect
F = Disconnect with Fuses

BLOWER OPTIONS
A = PSC Blower
B = Hi-Static PSC
E = ECM
F = Hi-Static ECM Blower
G = ECM with Continuous Low Speed
H = Hi-Static ECM with Continuous Low Speed

DESIGN SERIES
A = Current

MISCELLANEOUS OPTIONS			
Filters: MERV (Depth)			
Option	4 (1 Inch)	8 (1 Inch)	13 (2 Inches)
Galv Drain Pan	0	F	G
SST Drain Pan	S	T	U
Sealed Openings	L	M	N
SST DP with Sealed	C	D	E

HORIZONTAL DISCHARGE OPENING ORIENTATION			
00, 0T	1H, 1T	2H, 2T	3H, 3T
X = None	B = Back	1 = Left + Front	7 = Front + Left + Right
	F = Front	2 = Left + Back	8 = Front + Right + Back
	L = Left	3 = Left + Right	9 = Front + Left + Back
	R = Right	4 = Right + Back	
		5 = Right + Front	
		6 = Back + Front	

SUPPLY AIR CONFIGURATION	
1H = Single Horizontal Supply	2T = Double Horizontal Supply + Top
2H = Double Horizontal Supply	
3H = Triple Horizontal Supply	3T = Triple Horizontal Supply + Top
0T = Top Only	
1T = Single Horizontal Supply + Top	00 = Field Cut (No Openings)

RISER ARRANGEMENT	
1 = Right Hand Risers	8 = Left Hand Single Riser
2 = Left Hand Risers	9 = Back Single Riser
3 = Back Risers	C = Right Hand Single Riser with Cover
4 = Right Hand Risers with Cover	
5 = Left Hand Risers with Cover	D = Left Hand Single Riser with Cover
6 = Back Risers with Cover	
7 = Right Hand Single Riser	E = Back Single Riser with Cover

CABINET OPTIONS					
Cabinet Height	No OA Options	LEFT Top OA Entry (4-inch Round)	Top OA Entry (4-inch Round with Motorized Damper)	RIGHT Top OA Entry (4-inch Round)	Top OA Entry (4-inch Round with Motorized Damper)
88 inch	A	G	L	R	W
80 inch	B	H	M	T	X
88 inch with 2-inch Stand	C	J	N	U	Y
80 inch with 2-inch Stand	E	1	3	5	7
80 inch with 4-inch Stand	D	K	P	V	Z
80 inch with 8-inch Stand	F	2	4	6	8

## CHASSIS NOMENCLATURE

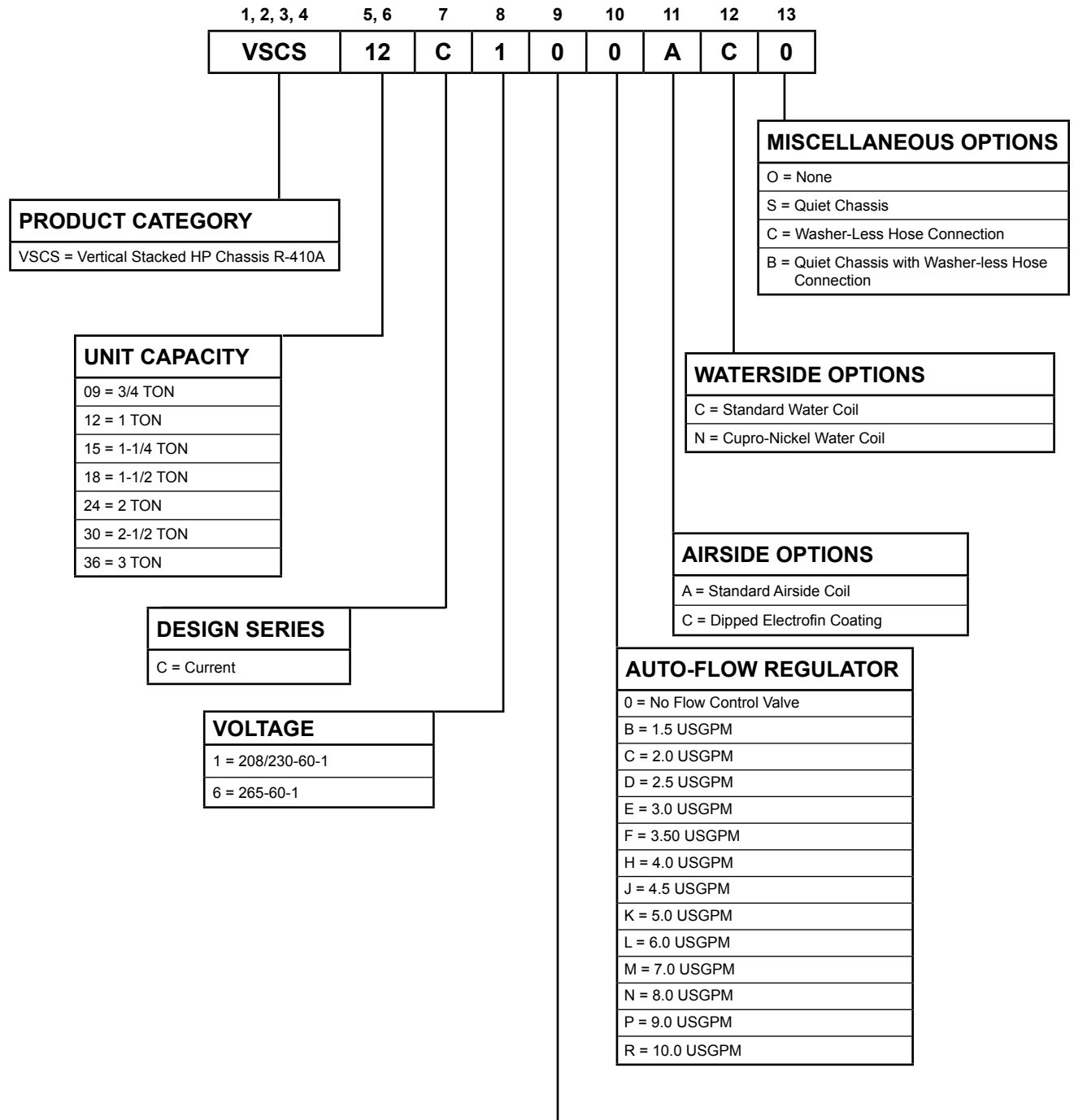

<b>WATER VALVE &amp; PUMP OPTIONS</b>				
VALVE OPTIONS	VALVE ONLY	Y-STRAINER	PUMP*	Y-STRAINER & PUMP*
No Water Control Valve	O	S	P	B
Motorized 2-Way Shut-Off Valve	M	Y		
Motorized 3-Way Shut-Off Valve	N	V		

\*Only available with single riser cabinet (VPT)

# RISER NOMENCLATURE

1, 2, 3    4    5, 6    7, 8    9    10    11    12    13    14, 15, 16    17    18, 19    20

**VBR - CW 09 M 1 0 S 2 120 S 4C M**

CABINET TYPE
VBR = Standard Cabinet
VMR = Master Cabinet
VTR = Single Riser Cabinet
VUR = Single Riser Master Cabinet

SHIPPING METHODS
L = Ship Loose
M = Factory Mount

PRODUCT CATEGORY
CW = Supply, Return Riser
DN = Drain Riser

INSULATION OPTIONS
00 = No insulation
3C = 3/8 inch
4C = 1/2 inch
6C = 3/4 inch

SIZE
09 = 3/4 TON
12 = 1 TON
15 = 1-1/4 TON
18 = 1-1/2 TON
24 = 2 TON
30 = 2-1/2 TON
36 = 3 TON

CABINET HEIGHT
S = Standard (88 inches)
R = Reduced (80 inches)

COPPER TYPE
M = Type M
L = Type L

**RISER LENGTH (INCHES)**

RISER END OPTIONS
1 = Standard
2 = Reduce Up
3 = Reduce Down
4 = Cap Up
5 = Cap Down
6 = Extension /Express

VALVE OPTIONS
0 = No Valve
3 = 1/2 inch Nexus Valve
5 = 1/2 inch JIC Valve
6 = 3/4 inch JIC Valve

SWAGE OPTIONS
S = Swaged
P = Plain End

SATELLITE STUB-OUT OPTIONS
0 = No Stub-Out
1 = 1/2 inch Stub-Out
5 = 3/4 inch Stub-Out

## TABLE OF CONTENTS

<b>SECTION 1 - INSTALLATION</b> .....	<b>9</b>
Notice and Disclaimer .....	9
Disclaimer.....	9
Pre-Installation .....	9
Shipping .....	9
Inspection and Storage .....	9
Preparations for Installing the Unit .....	10
Rigging .....	11
Cabinet Riser Installation .....	11
Placing the Cabinet .....	11
Single Riser Cabinet Dimensions .....	14
Riser Loop .....	16
Hoses .....	16
Electrical Wiring.....	19
Field-Installed Power Wiring.....	19
Field-Installed Low Voltage Wiring .....	19
Optional Surface Mount Thermostat Connection Wiring .....	20
Optional Remote Mounted Thermostat Wiring .....	20
Optional ADA Door Mounted Thermostat .....	20
ECM Continuous Fan .....	20
Closet and Drywall Installation .....	21
Acoustic RA Panel.....	21
Supply Air Ductwork .....	25
Horizontal Supply Air .....	25
Top Discharge Supply Air .....	25
Top Mounted Fresh Air Intake .....	28
Top Mounted Fresh Air Intake with Motorized Damper .....	28
System Flushing and Cleaning.....	29
Flushing the System.....	29
Cleaning the System .....	30
Chassis Installation .....	32
Installing Units with JIC Style (37° Flare) Valve Connection and Hoses .....	32
<b>SECTION 2 - OPERATION</b> .....	<b>35</b>
Pre Start-Up Checklist.....	35
Initial Start-Up.....	35
System Loop Temperatures.....	36
Fan Speed Adjustment .....	37
Electrical Data .....	41
Unit Controls.....	43
Sequence of Operation .....	43
Continuous Blower .....	43
Safety Control Reset .....	43
Safety Controls.....	44
Random Start .....	45
Compressor Protection.....	45
Microprocessor Control Unit Flash Codes.....	45
Communication .....	45
<b>SECTION 3 - MAINTENANCE</b> .....	<b>47</b>
<b>APPENDIX</b> .....	<b>49</b>
<b>R-410A QUICK REFERENCE GUIDE</b> .....	<b>53</b>

## LIST OF FIGURES

<b>FIGURE 1</b> - Ideal Riser Insertion Depth .....	12
<b>FIGURE 2</b> - Correct/Incorrect Stub-Out Positions in Cabinet Riser Opening.....	12
<b>FIGURE 3</b> - Single Riser Cabinet and Floor Sleeve Dimensions .....	14
<b>FIGURE 4</b> - Master/Satellite Configuration for Single Riser Cabinets.....	15
<b>FIGURE 5</b> - Standard Factory Supplied JIC Flare Hose Kits and Risers.....	17
<b>FIGURE 6</b> - Optional Field Supplied Risers with Factory Supplied JIC Flare Hose Kits and Shut-Off Valves .....	17
<b>FIGURE 7</b> - Riser Connections - Standard Style Single Riser .....	18
<b>FIGURE 8</b> - Riser Connections - Master Style Single Riser.....	18
<b>FIGURE 9</b> - Field Wiring Diagram .....	19
<b>FIGURE 10</b> - Remote Thermostat Wiring.....	20
<b>FIGURE 11</b> - Unit Switch Plate with ADA Thermostat Connection .....	20
<b>FIGURE 12</b> - Critical Return Air (RA) Panel with Cabinet Installation Dimensions .....	22
<b>FIGURE 13</b> - Return Air (RA) Panel Cross Section Installation (Floor Level) .....	23
<b>FIGURE 14</b> - Return Air (RA) Panel Dimensions .....	23
<b>FIGURE 15</b> - Optional Return Air (RA) Panel with ADA Mounted Thermostat .....	24
<b>FIGURE 16</b> - Supply Grille with Volume Damper and 1/8-inch Neoprene Tape Applied to Its Perimeter.....	25
<b>FIGURE 17</b> - Unit-Mounted Supply Grille Installation Dimensions.....	26
<b>FIGURE 18</b> - Damper Plate Fasteners.....	28
<b>FIGURE 19</b> - Remove the Red Cover .....	28
<b>FIGURE 20</b> - Position the Black Cover.....	29
<b>FIGURE 21</b> - System Flushing and Cleaning.....	30
<b>FIGURE 22</b> - Fresh Air Opening - Left Hand and Right Hand Unit.....	31
<b>FIGURE 23</b> - Lift the Chassis Front.....	32
<b>FIGURE 24</b> - Tilt the Chassis .....	33
<b>FIGURE 25</b> - Insert the Chassis.....	33
<b>FIGURE 26</b> - Pivot the Chassis.....	33
<b>FIGURE 27</b> - Slide the Chassis.....	33
<b>FIGURE 28</b> - Check the Chassis Alignment.....	34
<b>FIGURE 29</b> - <b>Chassis with Pump</b> .....	<b>37</b>
<b>FIGURE 30</b> - <b>Chassis with Pump (Detail)</b> .....	<b>37</b>
<b>FIGURE 31</b> - PSC Motor Wiring Diagram .....	49
<b>FIGURE 32</b> - ECM Wiring Diagram .....	50
<b>FIGURE 33</b> - Continuous Fan with ECM Wiring Diagram .....	51
<b>FIGURE 34</b> - Motorized Damper ECM Wiring Diagram .....	52

## LIST OF TABLES

<b>TABLE 1</b> - Single Riser VSHP Unit Physical Data .....	13
<b>TABLE 2</b> - Cabinet Dimensions .....	14
<b>TABLE 3</b> - Chassis Hoses.....	16
<b>TABLE 4</b> - Typical Wiring Connections .....	19
<b>TABLE 5</b> - Return Air (RA) Panel Size.....	23
<b>TABLE 6</b> - Unit Supply Opening Sizes.....	27
<b>TABLE 7</b> - Unit Supply Face Velocity (FPM).....	27
<b>TABLE 8</b> - Cabinet Dimensions .....	31
<b>TABLE 9</b> - Operating Limits .....	36
<b>TABLE 10</b> - Nominal Operating GPM .....	36
<b>TABLE 11</b> - PSC Standard Blower Performance (CFM).....	38
<b>TABLE 12</b> - PSC High Static Blower Performance (CFM).....	38
<b>TABLE 13</b> - ECM Standard Blower Performance (CFM).....	39
<b>TABLE 14</b> - ECM High Static Blower Performance (CFM) .....	39
<b>TABLE 15</b> - ECM Blower Performance - All Speed Taps (CFM).....	40
<b>TABLE 16</b> - PSC - Standard Blower .....	41
<b>TABLE 17</b> - PSC - Optional Hi-Static Blower.....	41
<b>TABLE 18</b> - PSC - Standard Blower (265 Volt).....	41
<b>TABLE 19</b> - PSC - Optional Hi-Static Blower (265 Volt).....	41
<b>TABLE 20</b> - ECM - Standard Blower.....	42
<b>TABLE 21</b> - ECM - Optional Hi-Static Blower .....	42
<b>TABLE 22</b> - ECM - Standard Blower (265 Volt) .....	42
<b>TABLE 23</b> - ECM - Optional Hi-Static Blower (265 Volt) .....	42
<b>TABLE 24</b> - Flash Codes .....	45
<b>TABLE 25</b> - Water Quality Table .....	46



## SECTION 1 - INSTALLATION

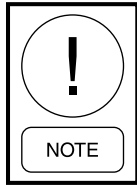

*After installing the unit, show the user how to turn off the electricity to the unit. Point out the control and switch locations for turning off the electricity.*

*Ensure the user understands the importance of following all safety precautions.*

### NOTICE AND DISCLAIMER

This unit contains refrigerant installed by the factory that is approved for use in the unit's intended country of installation or market. Distributors are only authorized to provide refrigerants that have been approved for use in the countries or markets they serve.

The refrigerant used in this unit is identified on the unit's nameplate and in this manual. Any additions of refrigerant into this unit must comply with the country's requirements with regard to refrigerant use and should be obtained from manufacturer approved distributors. Use of unapproved refrigerant substitutes will void all warranties and can cause injury or death.

### Disclaimer

Customer modifications to certified products are prohibited. If performed without the express written approval of the manufacturer, modifications will void all warranties (expressed or implied) and may result in hazardous situations resulting in equipment damage, serious physical injury or property damage, or death.

The manufacturer has certified the product as being compliant with applicable government and/or industry standards. Product certification is designated either on the product itself or in the product literature. The certification mark identifies the applicable standards as well as the Nationally Recognized Test Lab (NRTL) or other testing facility that conducted the testing, where applicable.

If changes are made to the product, an engineering review is required to assess the impact to the product certification. In some instances, the changes may require that the NRTL or testing facility review and re-approve the product by means of a field or site inspection and certification.

Modifications may invalidate product certifications or violate country standards. Any person or entity making changes to the product is responsible for obtaining the required engineering review and approval, as well as covering certification and other related costs.

### PRE-INSTALLATION

After installing the unit, give this IOM to the end user. If help is needed with any of the installation instructions or matters relating to the unit, contact the sales office where you bought the unit. You can also refer to the unit rating plate for a contact name.

### Shipping

Cabinets and risers ship in one of the following configurations:

- Cabinets are stacked on their side with risers attached. Chassis ship on separate skids.
- Risers ship loose, packaged in boxes and sorted by floor. Cabinets ship upright up to four per skid. Chassis ship on separate skids.
- Risers ship loose, packaged in boxes, and sorted by floor. Cabinets ship upright on skids with chassis inside the cabinet. Chassis electrical and water connections are not installed. The chassis is secured to the service panel. Remove the screws before removing the service panel and chassis.

The cabinet must remain standing upright. Do not place cabinets on their side with the chassis inside.

### Inspection and Storage

Store cabinets, chassis, and risers the same way they were shipped. Ensure the storage area is dry and protected from the environment. Keep the units in their upright position. If the risers are stored at the job site, ensure the pipe ends are capped to prevent foreign object debris and contamination.

In areas where construction is not complete (including dry wall, plaster, paint, and where any emission of dust particulates or fumes from outgassing are present), all precautions must be taken to protect the cabinet, openings, and chassis from contamination or physical damage.

Upon delivery, perform the following inspections:

1. Inspect the unit for shipment damage. Notify the Transportation Company of any damage and note the damage on the shipping receipt.



***Rough handling may dislocate and damage internal components.***

2. Inspect the riser projections at each end of the cabinet for misalignment or end damage that would prevent making an acceptable connection.
3. Inspect the thermostats and other accessories that have been shipped separately for quantity and transit damage.

Store the refrigeration chassis in the normal upright orientation to maintain oil in the compressor sump.

### Preparations for Installing the Unit

Before installing the unit, perform the following preparations:

- Verify the model number on the unit nameplate with the ordering and shipping information to ensure the correct unit has been shipped.
- Carefully inspect each unit before delivery to the installation site. All cabinets may not be equipped with the same size riser or the same air supply grille arrangement. In most cases, each cabinet is individually tagged for a specific location in the building.
- Keep the cabinet sealed with the shipping materials until all plastering, painting, and construction work is complete.
- Remove the inner service panel and manually check the blower wheel for free rotation.
- Match the refrigeration chassis to the proper cabinets by referring to the cabinet and chassis nameplate and label information.
- Remove the chassis refrigeration access panel (top cover) and inspect the unit. Ensure that the refrigerant tubing is free from obvious physical damage and kinks, and check that piping does not touch other unit components.

- Ensure the compressor is mounted on neoprene isolators with metal spacing sleeves inside. Secured it with nuts that are snug against the metal spacer sleeves.
- Inspect all electrical connections. Connections must be clean and tight at the terminals.



***DO NOT USE THE RISERS TO LIFT THE CABINET ASSEMBLY!***



***DO NOT install this unit outdoors.***



***A compressor/unit comprises a pressurized system. Never loosen threaded joints while the system is under pressure and never open pressurized system parts.***



***Before servicing, open and tag all disconnect switches.***



***Do not install units in a flammable environment due to the danger of an explosion.***



***Safety guards, shields, barriers, covers, and protective devices must not be removed while the compressor/unit is operating.***



***All safety features, disengagement, and interlocks must be in place and function correctly before the equipment is put into operation. Never bypass or wire around any safety device.***



*Use gloves and protective goggles where appropriate and have a gas mask close at hand. Use electrical protection equipment and tools suited for electrical operations.*



*Personnel must be qualified according to national safety rules and regulations.*



*Only manufacturer-qualified personnel should install this system. If not, it may cause water leakage, electric shock, or fire.*

### RIGGING



*Follow all applicable regulations and safety practices during rigging and lifting.*

Prepare and follow a written rigging and lifting plan. Lifting must be directed by a trained, professional rigger.

Spreader bars must be used and must be long enough to prevent rigging from contacting the unit. Use only the designated lift points according to the unit's manual and use ALL lifting points.

Locate the center of gravity through trial lifts to account for possible variations in unit configuration. Use rigging and lifting techniques that keep the unit stable and level. Keep clear of the unit when lifted.

### CABINET RISER INSTALLATION



*Do not use the risers to lift or move the cabinets.*

Risers are not designed to support or lift any part of the cabinet. Do not use them to lift a cabinet. The risers are attached using nylon ties to allow for slight adjustments during installation, and expansion of riser column during operation. Care must be taken during installation to avoid damage to risers and riser stub-outs.



*Improper handling and installation of risers could damage riser stub-outs and valves which could result in property damage, serious injury, or death.*



*Do not allow the risers to bottom out. Riser stub-out should be centrally located with the stub-out opening of the cabinet riser. Do not allow riser stub-outs or risers to contact the cabinet sheet metal.*



*Do not drag risers on floor while moving the cabinet.*

When the risers are shipped loose, riser installation can be completed before cabinet installation. When installing risers, ensure the riser stub-outs are centered in the cabinet openings. Ensure that the risers cannot bottom out in swage (see *Figure 1 on page 12*).

When the risers are shipped attached to cabinets, complete the installation of risers and cabinets at the same time. Detaching the riser from the cabinet is unnecessary.

### Placing the Cabinet

The correct location of the cabinet in relation to the floor sleeve and risers is shown in *Figure 3 on page 14*. To place the cabinet correctly, perform the following steps:

1. Place the cabinet in a horizontal position on the floor adjacent to its installation location (when risers are attached to cabinet).

The units are designed to accommodate a maximum supply and return riser stub-out movement of 1-1/2 inches due to expansion and contraction (a total movement of 3 inches). If the total calculated riser expansion or contraction exceeds 1-1/2 inches, the field must provide expansion compensation.

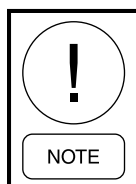

*The initial positioning of the riser stub-out is correct when the top of the riser pipe is 3 inches above the top of the cabinet (applies to standard riser models only: VTR/VUR)*

2. Install field or factory-provided riser extensions, if required, to the unit-mounted risers prior to moving the cabinet into final position.
3. Raise the cabinet upright. Lower the risers through the floor cutout, aligning the risers into the swaged section of the unit on the floor below.

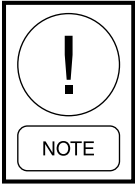

**Take extra care not to scrape or dent risers during positioning. The riser tailpiece should insert approximately 2 inches into the 3-inch long swaged section of the unit below.**



**DO NOT allow the riser tailpiece to bottom out into the swaged section. This ensures the correct riser positioning and compensates for variations in floor-to-floor dimensions.**

4. Center the risers in the pipe chase, and level the cabinet using shims as necessary.
5. Plumb risers in two planes to ensure proper unit operation and condensate drainage.
6. Anchor the cabinets into place using rubber isolated sheet metal angles. Approved and tested sheet metal angles are available from factory.

It is recommended to place cabinets on vibration isolation pads to reduce noise transmission into the floor.



**Do not drill or drive screws into the cabinet in the area of the internal drain pan.**

7. Center the risers' horizontal stub-outs (complete with factory-installed shut-off valves) in the cabinet slot openings. Ensure that the stub-outs are perpendicular to the side/back panel.
8. Verify all risers are vertical and that they penetrate the swaged joint at least 1 inch.

Factory provided risers come with a 3-inch deep swage. Do not allow risers to completely bottom out at 3 inches in the swage. The 3-inch swage depth is oversized to allow for adjustments, if necessary, to keep riser stub-outs and valves centered in the cabinet opening.

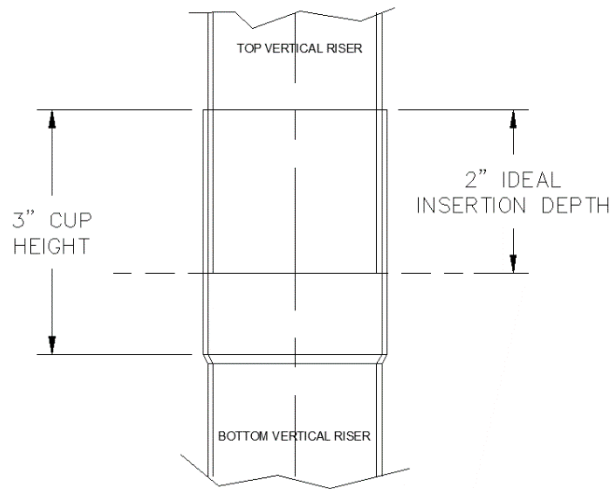

LD23535

**FIGURE 1 - IDEAL RISER INSERTION DEPTH**

9. Center the riser stub-outs in the cabinet opening to allow for expansion and contraction. Riser stub-outs must not contact any sheet metal opening. Otherwise, damage can occur to the stub-outs, resulting in water leaks and property damage.

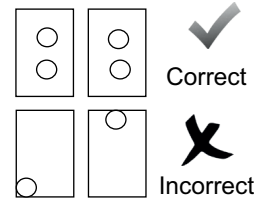

LD23536

**FIGURE 2 - CORRECT/INCORRECT STUB-OUT POSITIONS IN CABINET RISER OPENING**

10. Braze or solder riser joints with industry accepted solder or brazing rod material.



**The riser system must be secured to the building structure. Cabinets are not designed to support the riser system.**

11. Secure the riser system at a minimum of one point to the building structure. Cabinets are not intended to support the riser system. If the temperature range of the system exceeds the allowed expansion and contraction limits (1-1/2 inches maximum), the installing contractor must make riser compensation provisions.
12. Ensure the individual unit shut-off valves are closed until the circulating loop system is cleaned and flushed.

**TABLE 1 - SINGLE RISER VSHP UNIT PHYSICAL DATA**

<b>MODEL SERIES</b>	<b>09</b>	<b>12</b>	<b>15</b>	<b>18</b>	<b>24</b>	<b>30</b>	<b>36</b>
Nominal Cooling (ton) <sup>1</sup>	0.75	1	1.25	1.5	2	2.5	3
<b>COMPRESSOR TYPE</b>	<b>ROTARY</b>			<b>SCROLL</b>			
Refrigerant Charge (oz)	21	25	34	38	44	48	50
<b>AIR COIL TYPE</b>	<b>ENHANCED COPPER TUBES, ENHANCED ALUMINUM FINNS</b>						
Face Area (sq.ft)	1.46	1.56	2.35	2.35	2.63	3.33	3.33
Rows/FPI	2/16	3/14	3/14	3/14	3/14	3/14	3/14
<b>WATER COIL TYPE</b>	<b>ENHANCED SURFACE CO-AXIAL</b>						
<b>STANDARD BLOWER/MOTOR</b>	<b>DWDI FORWARD-CURVED CENTRIFUGAL / PSC DIRECT-DRIVE</b>						
Diameter x Width (in)	9x4T	9x4T	9x7T	9x7T	9x7	9x8	9x8
Motor HP	0.10	0.10	0.17	0.17	0.25	0.33	0.50
<b>HI-STATIC BLOWER/MOTOR</b>	<b>DWDI FORWARD-CURVED CENTRIFUGAL / PSC DIRECT-DRIVE</b>						
Diameter x Width (in)	9x4T	9x4T	9x7T	9x7T	10x7T	10x8T	10x8T
Motor HP	0.10	0.17	0.17	0.25	0.33	0.33	0.50
<b>ECM BLOWER/MOTOR</b>	<b>DWDI FORWARD-CURVED CENTRIFUGAL / ECM DIRECT-DRIVE</b>						
Diameter x Width (in)	9x4T	9x4T	9x7T	9x7T	10x7T	9x8	9x8
Motor HP	0.33	0.33	0.33	0.33	0.33	0.50	0.50
<b>HI-STATIC ECM BLOWER/MOTOR</b>	<b>DWDI FORWARD-CURVED CENTRIFUGAL / ECM DIRECT-DRIVE</b>						
Diameter x Width (in)	9x4T	9x4T	9x7T	9x7T	10x7T	10x8T	10x8T
Motor HP	0.33	0.33	0.33	0.33	0.33	0.50	0.50
<b>CHASSIS WATER PUMP</b>	<b>CAST IRON WATER PUMP CW INTEGRAL CHECK VALVE (CARTRIDGE STYLE)</b>						
Pump HP	1/40	1/25	1/25	1/25	1/25	1/8	1/8
Water Connection (JIC) (in)	0.5	0.5	0.5	0.5	0.75	0.75	0.75
<b>FILTER QUANTITY-SIZE (IN)</b>	1-14x25x1	1-14x25x1	1-16x30x1	1-16x30x1	1-16x30x1	1-20x30x1	1-20x30x1
<b>CABINET WEIGHT (LB)<sup>2</sup></b>	130	130	145	145	150	175	175
<b>CABINET WRIGHT (LB)</b>	77	79	104	109	149	170	173

1. Nominal Capacity calculated in accordance with ARI/ISO Standard 13256-1 for Water Loop Application.  
 2. Cabinet weight is approximate and does not include weight of risers.

**SINGLE RISER CABINET DIMENSIONS**

**TABLE 2 - CABINET DIMENSIONS**

MODEL	A	B	RA FLANGE WIDTH (IN.)
09-12	17	17	16
15-24	20	20	19
30-36	24	24	23

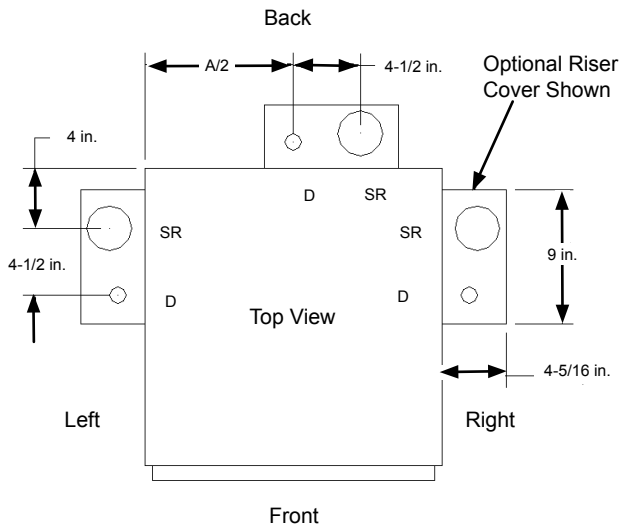

SR = Single Riser (Supply and Return)  
D = Drain Riser

Single Riser Floor Cutout

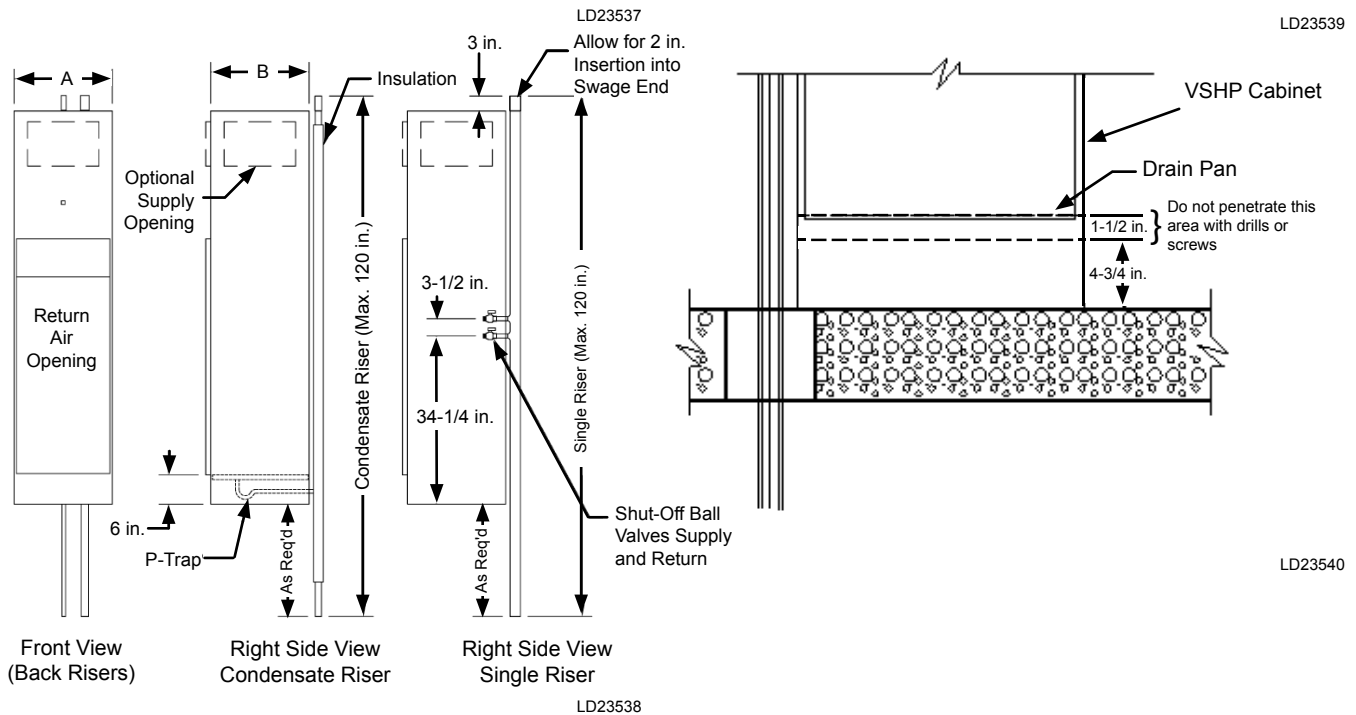
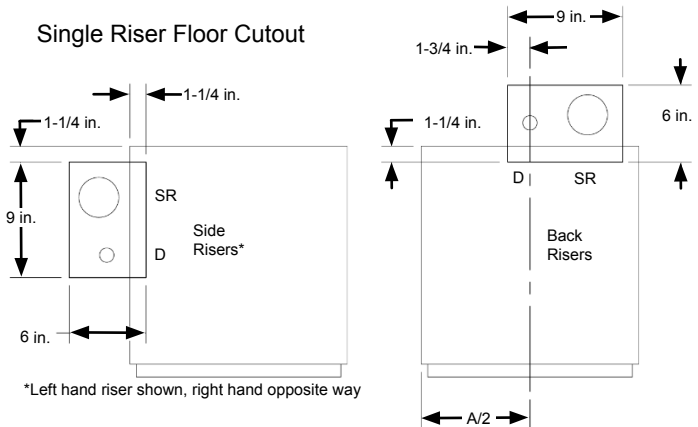

**FIGURE 3 - SINGLE RISER CABINET AND FLOOR SLEEVE DIMENSIONS**

**NOTES**

1. The single riser and condensate riser openings are pre-punched on all sides and field convertible. Cut the tabs to remove the knock-out.
2. The single riser openings are 9.5 inches x 2.5 inches. During riser installation, ensure the stub-out is centered in the supply and return openings.
3. The condensate P-trap is accessible either from the front by removing the bottom cover plate or from the top by removing the drain pan.
4. The floor cutouts are given for reference only. The actual opening might be affected by site conditions.
5. For the master/satellite configuration (see Figure 4 on page 15), the satellite cabinet water and drain connections must be field extended to match the satellite cabinet location. The use of elbows and extension beyond 24 inches is not permitted on the water side because of the potential for a higher water pressure drop.
6. A shut-off valve is not provided with the satellite side of the riser stub. Field-install shut-off valve with field hose kit (ordered separately).
7. See Figure 8 on page 18 for more details about installation.

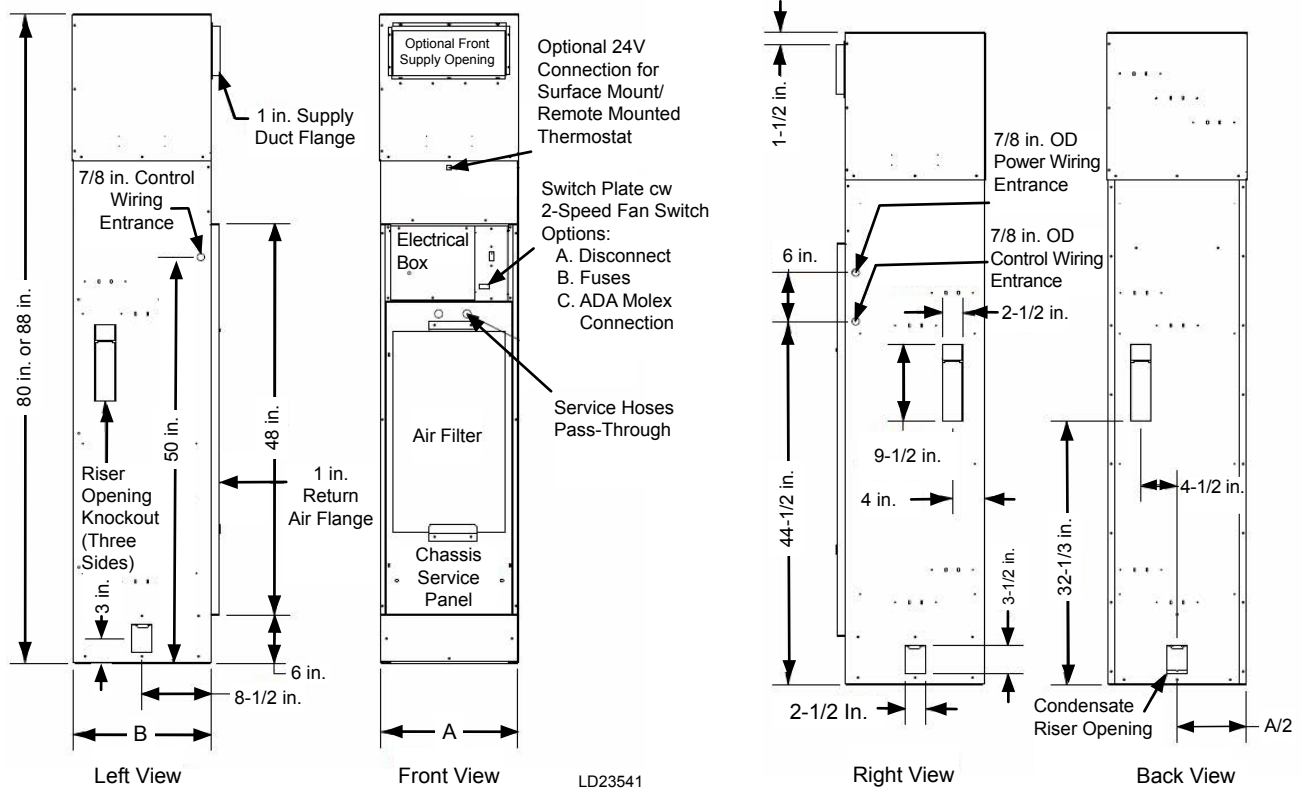

**FIGURE 3 - SINGLE RISER CABINET AND FLOOR SLEEVE DIMENSIONS (CONT'D)**

LD23542

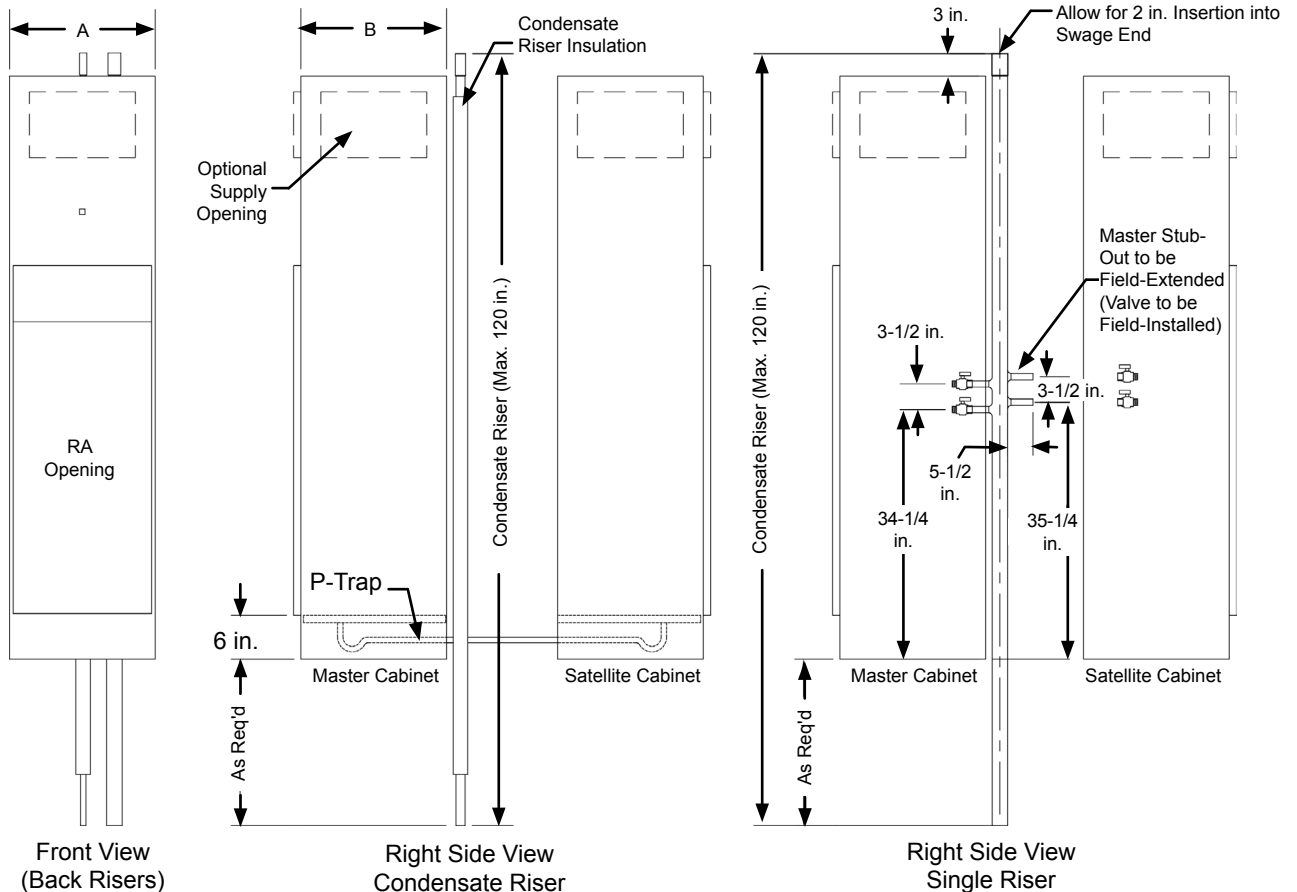

**FIGURE 4 - MASTER/SATELLITE CONFIGURATION FOR SINGLE RISER CABINETS**

LD23543

**NOTES**

See notes 5,6, and 7 on page 14.

## RISER LOOP

1. Install the following parts at the base of each supply and return riser to enable system flushing, balancing, and servicing:
  - A drain valve
  - Shut-off/balancing valves
  - Flow indicators
  - Drain tees

2. Install strainers at the inlet of each circulating pump.
3. Insulate loop water piping that runs through unconditioned areas of the building or outside the building.

When the loop water temperature is maintained between nominal operating limits of 60.0–90.0°F, the piping does not sweat or suffer undue heat loss at conditioned space temperatures.

4. Install vents in the piping loop as required to bleed residual air from the piping system during filling and servicing.
5. Determine the riser shut-off valves and hose kits required for job-specific site conditions:
  - a. Factory supplied risers come with the appropriate hose kits with Joint Industrial Committee (JIC) type fittings (see *Figure 5 on page 17*).
  - b. For field supplied risers, it is recommended to order the appropriate JIC type field hose kits from the factory, complete with shut-off valves. Shut-off valves are to be field sweat connected to risers (see *Figure 6 on page 17*).
  - c. For satellite side cabinets, it is recommends ordering the appropriate JIC type field hose kits from the factory, complete with shut-off valves. Shut-off valves are to be field sweat connected to risers (see *Figure 6 on page 17*).

## HOSES

Ensure the correct hose type is matched with the compatible chassis model (see *Table 3 on page 16*). Install the JIC factory-provided hoses by completing the following steps:

1. Tighten by hand the screw connections to the male JIC fitting on the shut-off valve. Hold the ferrule stationary when tightening.
2. Tighten using backup wrench 1/4 turn further. Do not overtighten.



***When installing hoses, do not apply a twist or torque load on the hose.***



***When tightening hoses, hold ferrule stationary by hand while tightening the screw connections. Avoid tight bends, or water flow and high pressure drops may occur.***



***Hose gasket does not require extreme tightening to obtain a seal. DO NOT OVERTIGHTEN or damage to gasket or sealing surface will occur. Do not apply thread sealant.***



***Hoses must be hand tightened then further tightened no more than 1/4 turn. DO NOT APPLY EXCESSIVE FORCE!***



***ALWAYS USE A BACKUP WRENCH WHEN TIGHTENING HOSES TO VALVES! Otherwise, valve solder joint may fail, which could lead to property damage or serious injury!***

**TABLE 3 - CHASSIS HOSES**

CHASSIS MODEL	HOSE TYPE
09/12/15/18	1/2 inch JIC Female-Female
24/30/36	3/4 inch JIC Female-Female



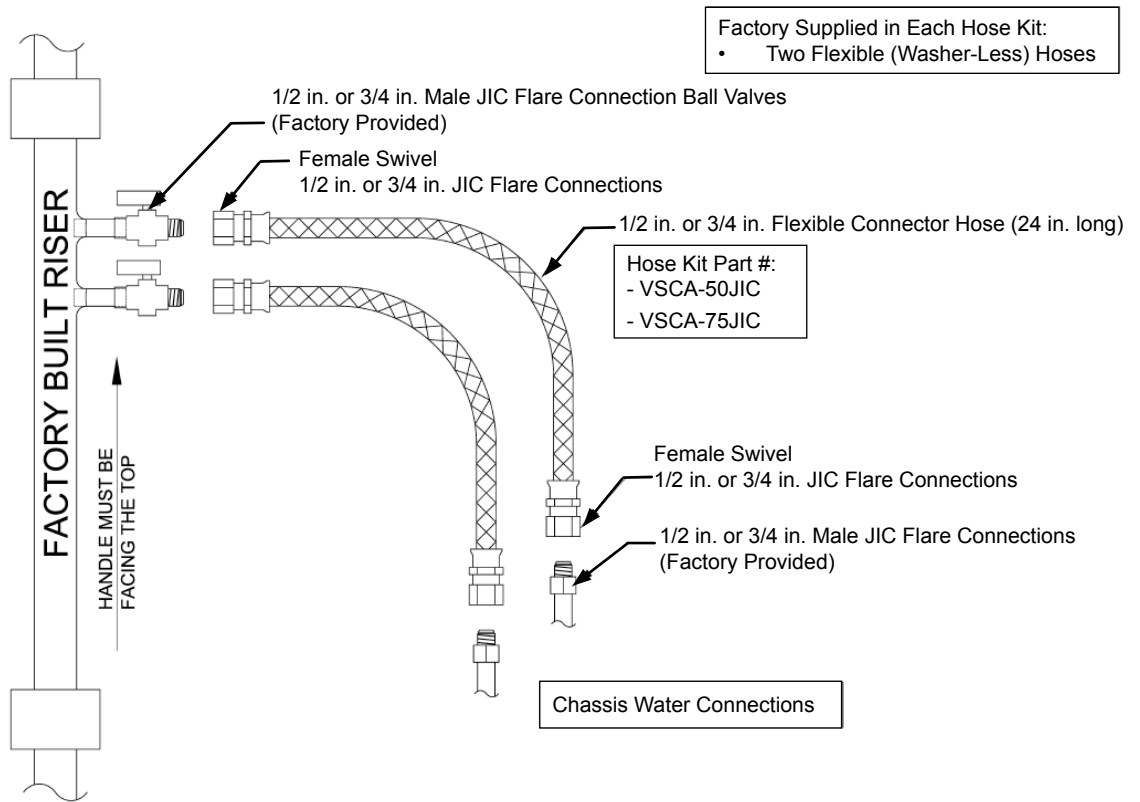

**FIGURE 5 - STANDARD FACTORY SUPPLIED JIC FLARE HOSE KITS AND RISERS**

LD23544

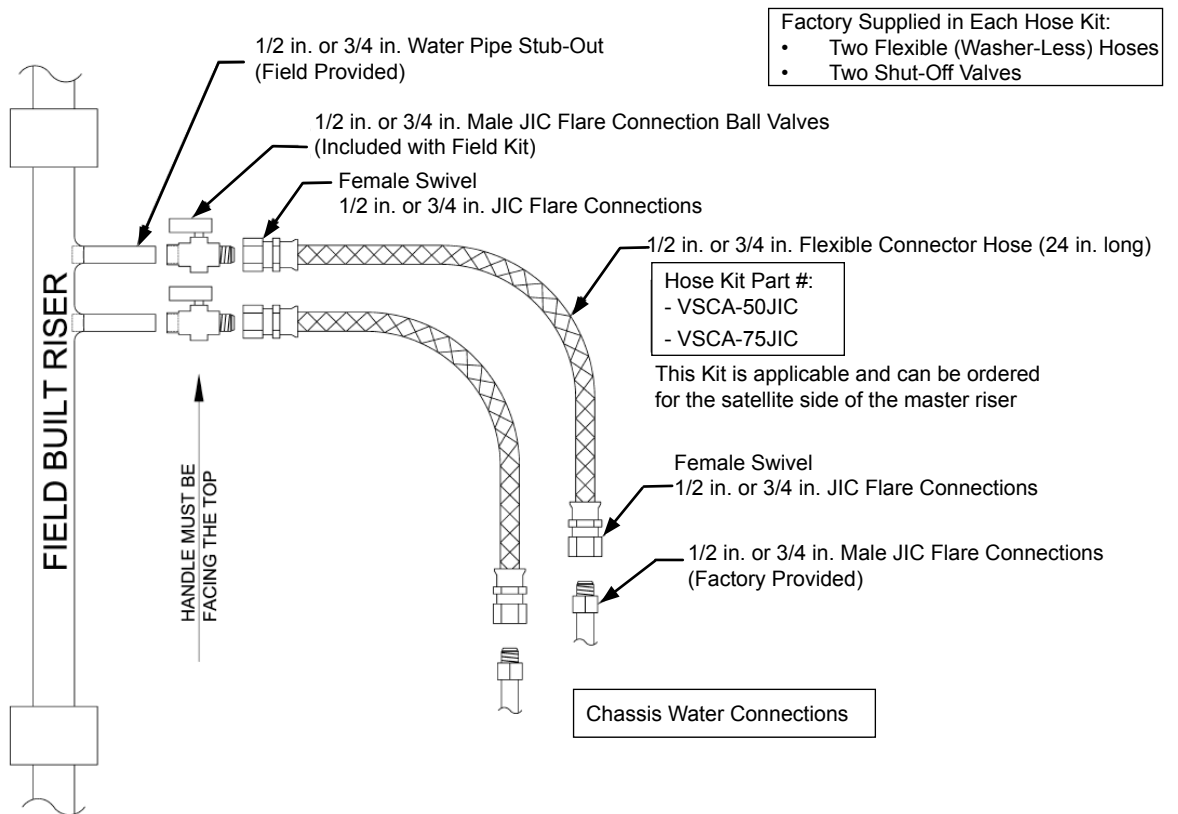

**FIGURE 6 - OPTIONAL FIELD SUPPLIED RISERS WITH FACTORY SUPPLIED JIC FLARE HOSE KITS AND SHUT-OFF VALVES**

LD23545

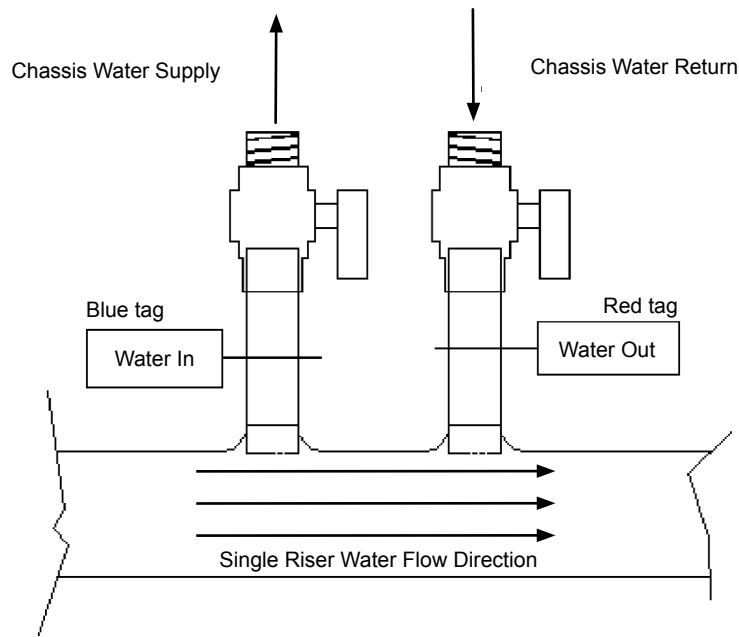

LD23546

**FIGURE 7 - RISER CONNECTIONS - STANDARD STYLE SINGLE RISER**

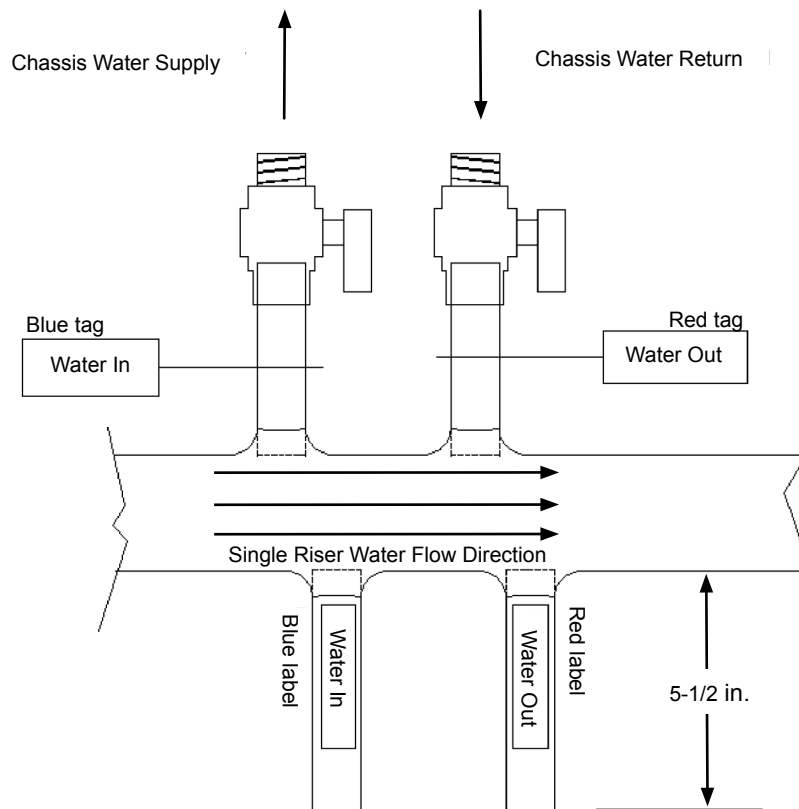

LD23547

**FIGURE 8 - RISER CONNECTIONS - MASTER STYLE SINGLE RISER**

**NOTES**

1. Prior to fabrication, communicate the main riser water flow direction to the factory.
2. Factory marked riser connections use color tags and labels.
3. The blue color indicates the chassis supply and the red color indicates the return connection.
4. The chassis water connections are marked using color labels indicating the correct water connections.
5. The factory satellite stub-out connection is 5-1/2 inches. The field can extend it up to 24 inches. The shut-off valve is field-installed.

## ELECTRICAL WIRING



**Lock all electrical power supply switches in the OFF position before installing the unit. Failure to disconnect power supply may result in electrical shock or death.**

### Field-Installed Power Wiring

Power wiring to the equipment must conform to all National Electrical Codes (NEC), local electrical codes, and must be performed by a licensed electrician.

Provide each unit with its own separate electrical circuit, means of circuit protection, and electrical disconnect switch. Follow current NEC ANSI/NFPA 70, CSA C22.1 C.E.C. Part 1, and state and local codes.



**Failure to provide shut-off means could cause electrical shock or fire, resulting in damage, injury, or death.**



**Use copper conductors only!**

Verify that the available unit power supply is compatible with the unit's nameplate rating. Ensure the breaker is properly sized as per the nameplate. The line voltage supply enters through the right hand side of the cabinet at the 7/8-inch power entrance knock-out.

Connect to the line side of the factory-installed terminal block. Unit terminals are not designed to accept other types of conductors. Failure to use copper conductors may result in equipment damage.

### Field-Installed Low Voltage Wiring

Select a location for the room thermostat, away from the supply air registers, on a draft-free interior wall that is far from lights, televisions, direct sunlight, or other heat sources.

Install thermostat by connecting the remote thermostat wiring to the microprocessor board low voltage terminal strip. See Figure 9 on page 19 for typical wiring connections.



**Locate thermostat away from supply drafts. Ensure the back of thermostat is sealed and protected from air drafts. Short cycling can result in damage to unit.**

TABLE 4 - TYPICAL WIRING CONNECTIONS

RECOMMENDED WIRE SIZE (GAUGE)	MAXIMUM LOW VOLTAGE WIRE LENGTH (FEET)
20	50
18	75
16	125

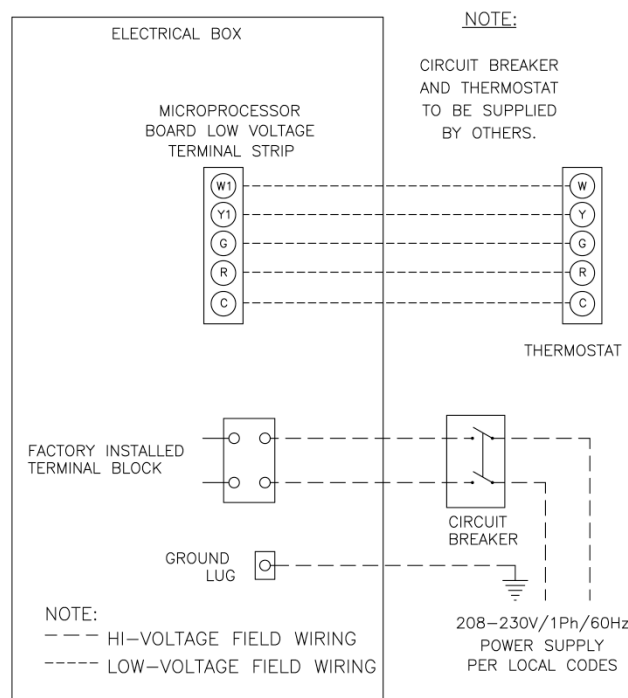

LD23548

FIGURE 9 - FIELD WIRING DIAGRAM

Ensure that the control wiring between the thermostat and the unit's terminations does not exceed 1 ohm.



**Resistance in excess of 1 ohm may cause component damage due to insufficient AC voltage supply.**

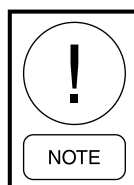

**Check all loads and conductors for grounds, shorts, or miswiring. Do not run the low voltage wiring in the same conduit with the high voltage power wiring.**

### Optional Surface Mount Thermostat Connection Wiring

For applications where a thermostat is mounted directly above the return air (RA) panel, select cabinet control option P (for example, VB12P). The thermostat Molex pigtail harness (shipped loose) is field wired to the thermostat terminals, and the Molex connector clips to the mating panel-mounted Molex connector on the unit cabinet, located 7 inches above the electrical box. See optional 24V surface mount connection in *Figure 3 on page 14*.

### Optional Remote Mounted Thermostat Wiring

For units ordered with an extended thermostat harness option, the thermostat is remotely mounted. A specific, plenum rated extended harness length can be ordered.

Use a low voltage 7/8-inch knock-out on either side of the unit at the electrical box to field wire the low voltage thermostat wiring. Use a field provided bushing to pass the harness inside the electrical box to the factory wired mating Molex harness. See *Figure 10 on page 20*.

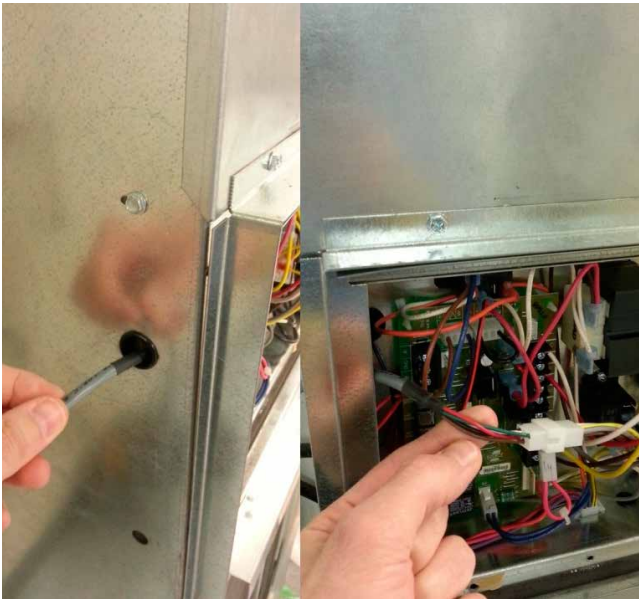

LD23549

**FIGURE 10 - REMOTE THERMOSTAT WIRING**

### Optional ADA Door Mounted Thermostat

For units ordered with ADA thermostat option, to meet the requirements of the Americans with Disabilities Act (ADA), the thermostat is located on the RA panel door at a height of 48 inches from the base of the cabinet. The unit is supplied with a custom RA door panel with thermostat mounting holes, a unit switch plate with a Molex connector, and an ADA Molex pigtail harness. See *Figure 14 on page 23*.

Wire leads from the ADA thermostat harness are field wired to the thermostat terminals. The Molex end of the ADA thermostat harness is field connected to the surface mounted Molex connector at the unit switch plate.

Mount the thermostat using the factory provided 1/4-inch number 8 screws. The ADA thermostat harness is plenum rated. It hangs in behind the RA door. For chassis servicing, unclip the harness from the unit switch plate.

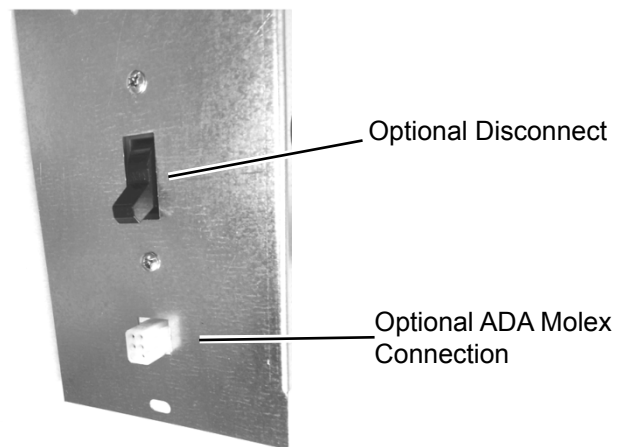

LD23550

**FIGURE 11 - UNIT SWITCH PLATE WITH ADA THERMOSTAT CONNECTION**

### ECM Continuous Fan

This option features a factory wired continuous low speed fan circuit. Because of the five available motor speed taps, the EC motor (ECM) offers an ideal range for supporting a continuous low speed fan.

The fan runs continuously on the low fan speed setting even if there is no demand for cooling or heating. The continuous fan is controlled by a dry contact to provide interlocking to the energy recovery ventilator (ERV) or room occupancy control. See *Appendix on page 49* for electrical schematics.

## CLOSET AND DRYWALL INSTALLATION

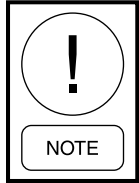

*To avoid potential vibration and noise issues, the RA panel should not contact any part of the unit cabinet or sleeve. Maintain a sufficient gap between the RA panel frame and cabinet!*

Build a closet enclosure for the cabinet that incorporates the RA panel size while maintaining a sufficient gap between the closet and the cabinet. This prevents the cabinet from contacting the RA panel and closet enclosure. See *Acoustic RA Panel on page 21, Figure 12 on page 22, and Figure 13 on page 23.*

1. Cover the supply and return openings with plastic or cardboard before installing drywall around the cabinet. This prevents dust or debris from entering the unit components.
2. Install the drywall using conventional construction methods. Do not fasten studs or drywall directly to the cabinet surface. Space the framing members according to the RA access and the type/quantity of supply air outlets. See *Figure 12 on page 22 and Figure 13 on page 23.*
3. Install sheetrock around the cabinet by securing the drywall to the building construction studs.
4. Cut holes around the supply air and RA openings to allow access to the unit chassis, unit controls, and the supply air connection.
5. Vacuum all the dust and construction debris from the unit drain pan, electrical box, and discharge plenum after cutting out the supply/return openings.



*To prevent electrical shorts and drain pan leaks, DO NOT penetrate unit components when driving screws near the unit control box or drain pan. Do not allow screws or nails to penetrate chassis, risers, electrical junction boxes, conduits, or to interfere with chassis removal.*

## ACOUSTIC RA PANEL

RA panels are painted standard appliance white. Carefully unpack RA panels from shipping box. RA panels with optional key locks require key locks to be field-installed to the slot in the panel door. ADA RA door panels come with an opening and pilot holes mounting a thermostat. The ADA harness for wiring the thermostat to the unit is shipped loose with the thermostats.

1. Locate the drywall opening at a distance from the unit. This prevents the RA panel from touching the unit sleeve. See *Figure 12 on page 22 and Figure 13 on page 23.*
2. Center the RA panel throat opening to the cabinet RA flange opening.
3. Fasten the RA panel to the frame opening using the screws provided. See *Figure 12 on page 22.*

*Figure 15 on page 24 shows the opening for mounting an ADA compliant thermostat at 48 inches above the floor. Note that the location of the opening on the door changes if the cabinet is ordered with a stand. A left hand opening door is shown. The RA panel with ADA is not reversible. It must be ordered in either a left or right hand opening configuration, determined by the location of the door hinge.*

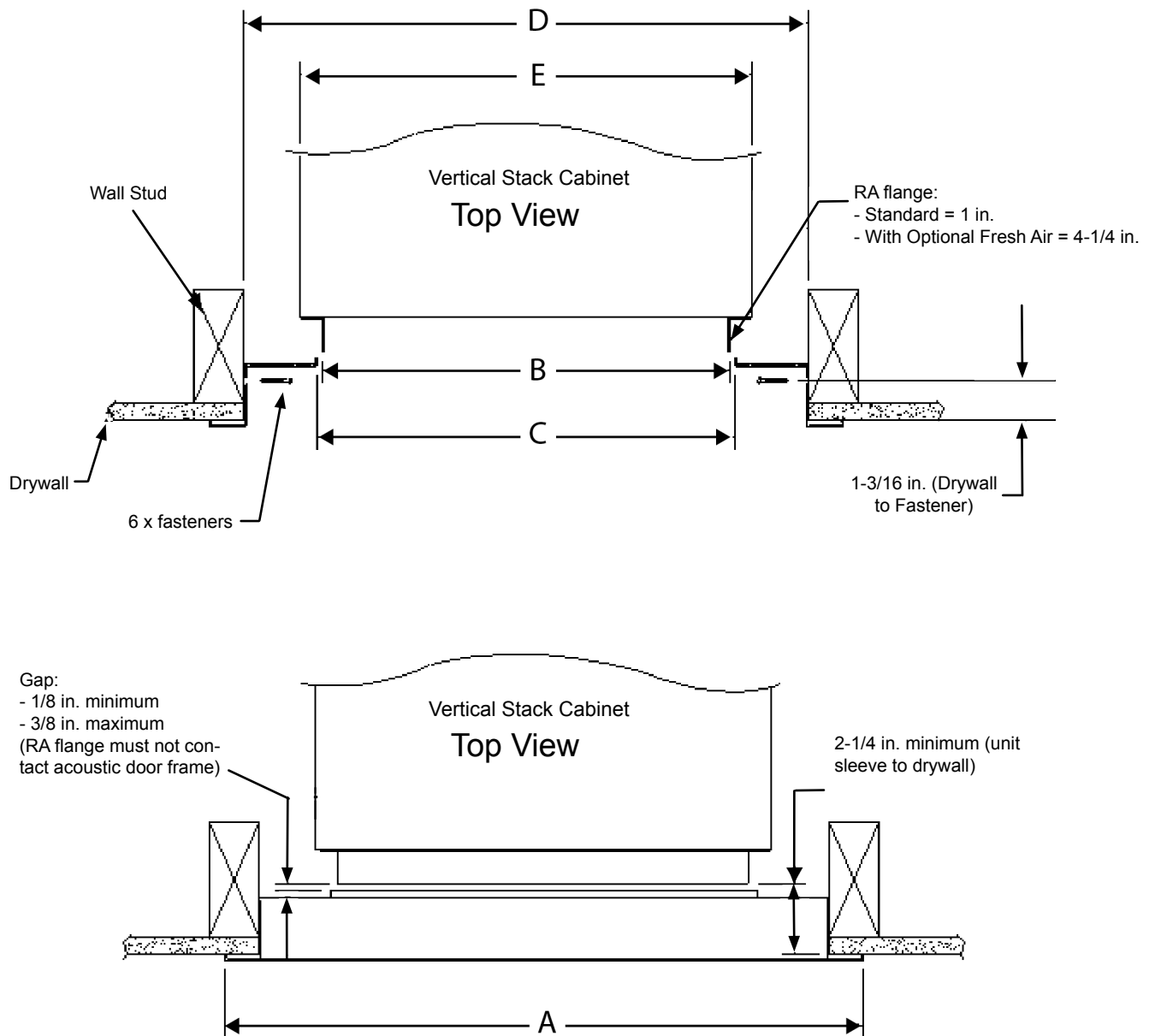

UNIT SIZE	A (PANEL WIDTH)	B (SLEEVE WIDTH)	C (RA PANEL OPENING)	D (ROUGH IN WIDTH)	E (UNIT WIDTH)
09/12	22 3/4	16	16 1/4	20 3/4 +/- 1/8	17
15/18/24	25 3/4	19	19 1/4	23 3/4 +/- 1/8	20
30/36	29 3/4	23	23 1/4	27 3/4 +/- 1/8	24

LD23551

**FIGURE 12 - CRITICAL RETURN AIR (RA) PANEL WITH CABINET INSTALLATION DIMENSIONS**

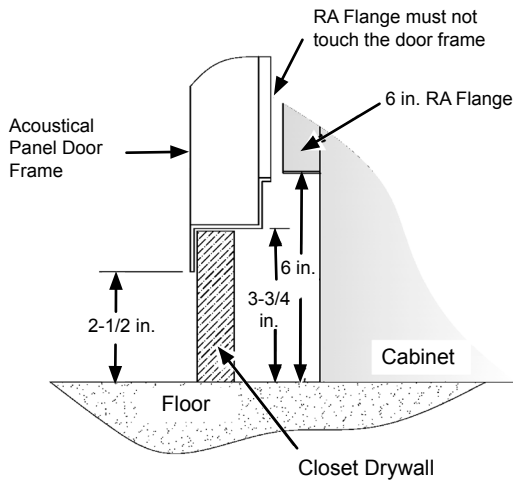

**FIGURE 13 - RETURN AIR (RA) PANEL CROSS SECTION INSTALLATION (FLOOR LEVEL)**

LD23552

*Figure 13 on page 23 shows a cutaway view for a standard cabinet with no stand. Add the stand height to the cabinet height to obtain the correct dimension of the RA panel from the floor.*

**TABLE 5 - RETURN AIR (RA) PANEL SIZE**

CHASSIS SIZE	A	B	C	D
VSCS09/12	22.75	20.50	16.25	18.50
VSCS015/18/24	25.75	23.50	19.25	21.50
VSCS30/36	29.75	27.50	23.25	25.50

**NOTES**

1. All dimensions are in inches.
2. The acoustic panel is coated in 'Appliance White'.
3. The acoustic panel can be installed on the right or left hand side.

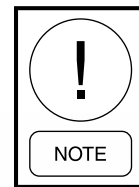

*For maximum RA flow, the flush mounted acoustic panel must be centered vertically and horizontally over the RA opening of the cabinet. Supply air duct collar extensions may be required to prevent short cycling.*

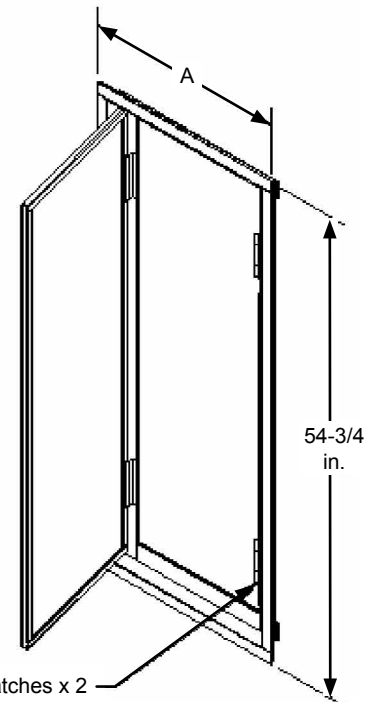
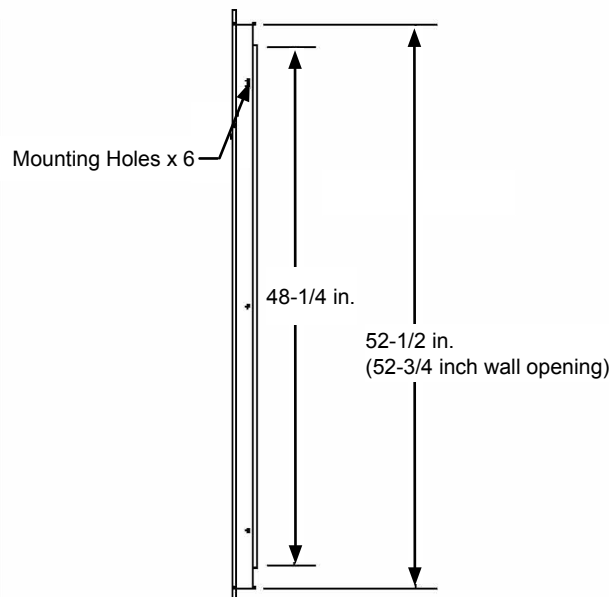
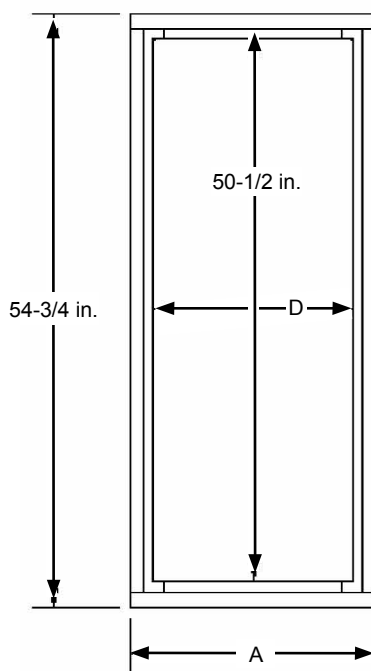
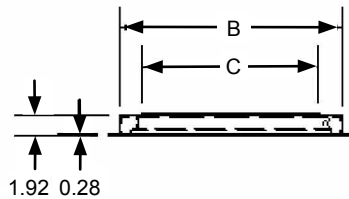

**FIGURE 14 - RETURN AIR (RA) PANEL DIMENSIONS**

LD23553

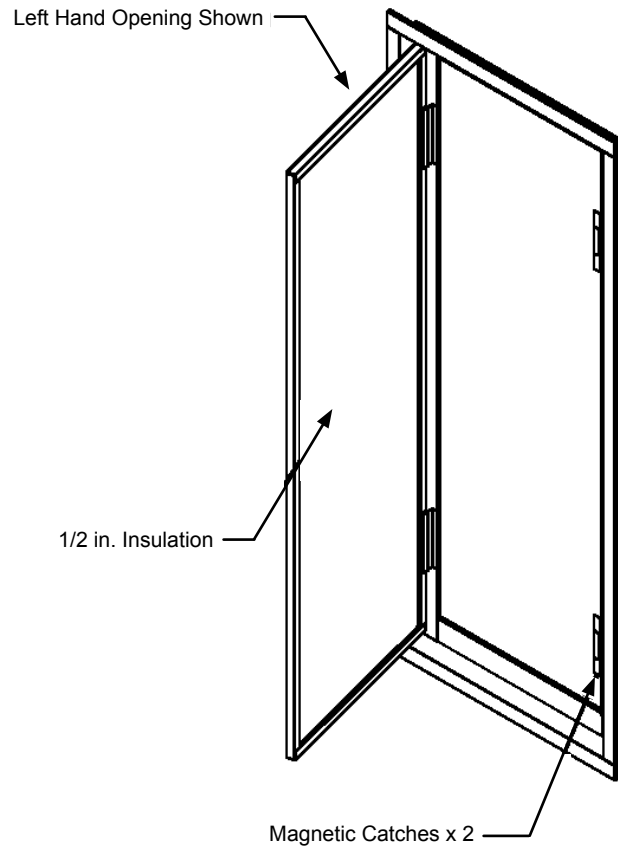
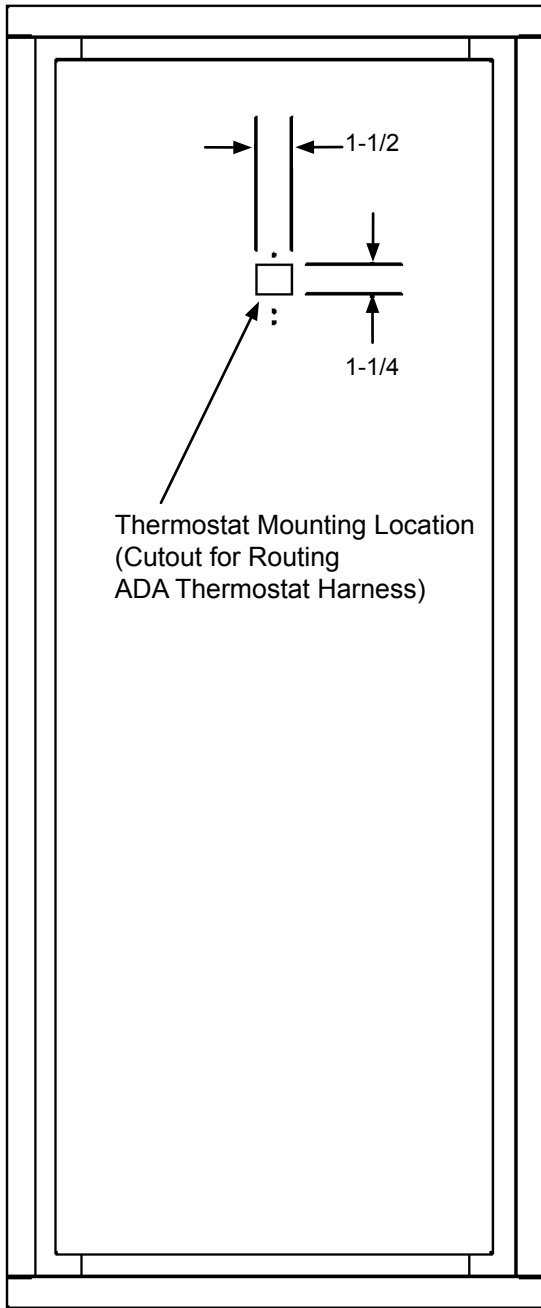

**NOTES:**

- Powder coated in appliance white
- Inside panel lined with 1/2 inch acoustical insulation
- Hinged panel complete with magnetic latches
- Panel comes either left or right hand opening

**FIGURE 15 - OPTIONAL RETURN AIR (RA) PANEL WITH ADA MOUNTED THERMOSTAT**

LD23554



## SUPPLY AIR DUCTWORK

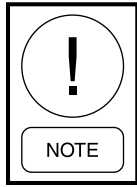

***Ensure there is no direct contact between cabinet sheet metal parts and drywall enclosure. This includes RA and supply air flanges. Failure to follow these instructions will negatively affect unit sound performance.***

### Horizontal Supply Air

A 2-inch duct flange (field provided) can be required to eliminate supply air recirculation when shallow profile, single deflection supply grilles are installed at the cabinet discharge openings. If the discharge from the cabinet is not ducted completely into the conditioned space, air can recirculate into the RA opening from the space inside the drywall enclosure.

Manufacturer supplied grilles have a clearance of 1/4 inch around the perimeter to fit inside the unit supply flange. Other grille manufacturers could have different clearances which should be verified.

Field supplied gasket must be applied in order to prevent air recirculation and vibration transfer when supply grilles are mounted to unit supply opening. When mounting supply grilles with optional volume damper directly to cabinet supply flange, the volume damper will fit inside the cabinet supply flange. It is not recommended to apply the 1/8-inch neoprene tape around the perimeter of the volume damper prior to inserting into the supply opening (see *Figure 16 on page 25*). This assists in reducing noise transmission and air recirculation into the unit closet.

For ducted openings, connect the unit supply opening to the supply ductwork using a watertight flexible duct connector. This minimizes the transmission of operating sounds through the supply ductwork. Elbows with turning vanes or splitters are recommended to minimize air noise due to turbulence and to help reduce static pressure.

### Top Discharge Supply Air

Units that are installed with a top discharge should be connected to the supply ductwork with a watertight flexible connector. This minimizes the transmission of operating sounds through the supply ductwork. Elbows with turning vanes or splitters are recommended to minimize air noise due to turbulence and to help reduce static pressure.

For information on available unit horizontal and top supply openings, see *Table 6 on page 27* and *Table 7 on page 27*. Recommended face velocity at the outlet supply grille is 300–500 FPM. These tables give face velocity at the unit supply openings in relation to *Table 6 on page 27*. To calculate the face velocity at the supply grille, take the FPM (*Table 6 on page 27* and *Table 7 on page 27*) and divide by the supply grille free area factor.



LD23555

**FIGURE 16 - SUPPLY GRILLE WITH VOLUME DAMPER AND 1/8-INCH NEOPRENE TAPE APPLIED TO ITS PERIMETER**

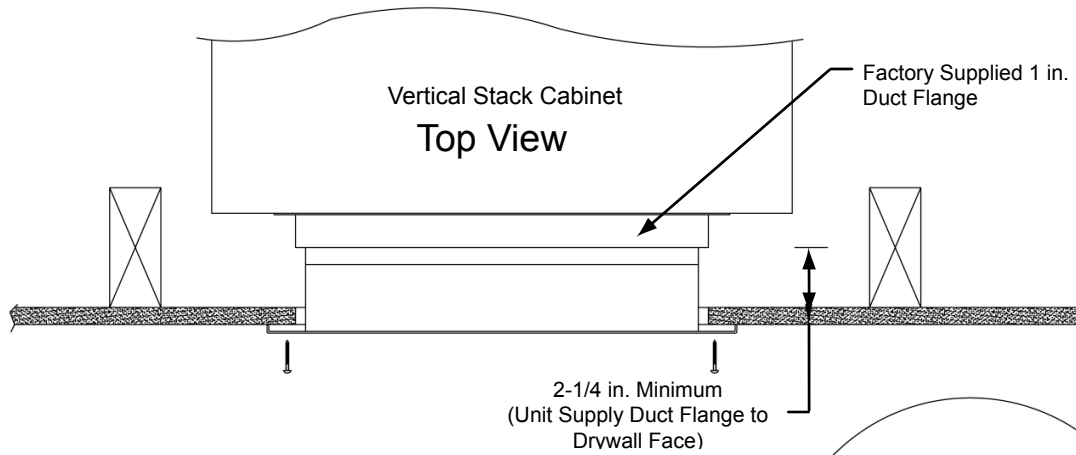
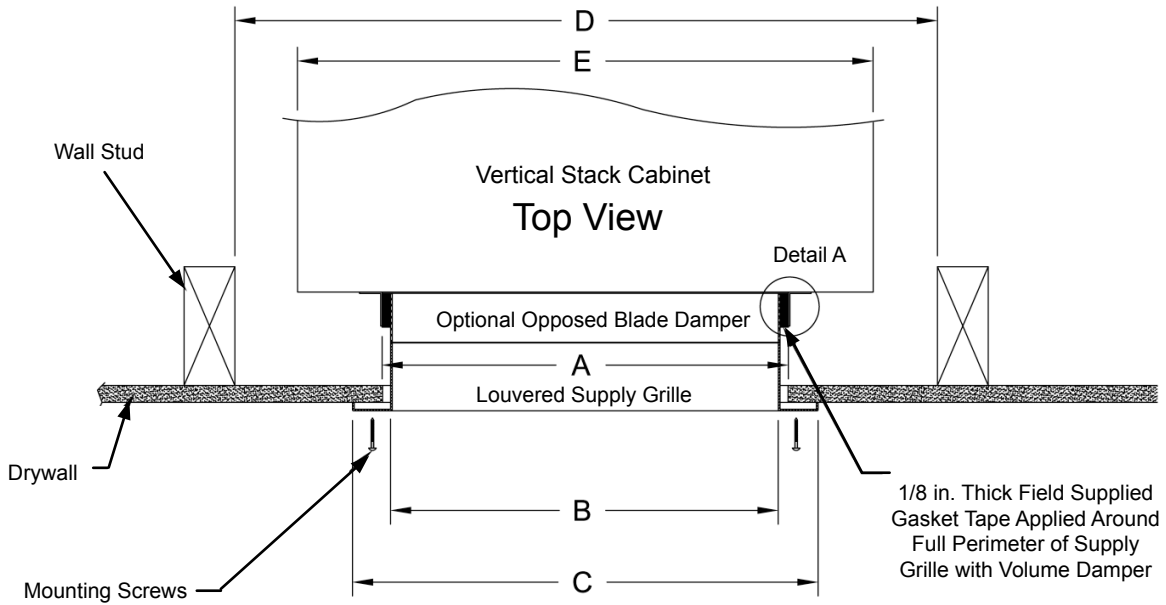

UNIT SIZE	A (SUPPLY GRILLE NOMINAL WIDTH)	B (GRILLE WIDTH)	C (GRILLE FLANGE WIDTH)	D (ROUGH IN WIDTH)	E (UNIT WIDTH)
09/12	X	$B = X - 1/2$	$C = X + 1-3/4$	$20\ 3/4 \pm 1/8$	17
15/18/24	X	$B = X - 1/2$	$C = X + 1-3/4$	$23\ 3/4 \pm 1/8$	20
30/36	X	$B = X - 1/2$	$C = X + 1-3/4$	$27\ 3/4 \pm 1/8$	24

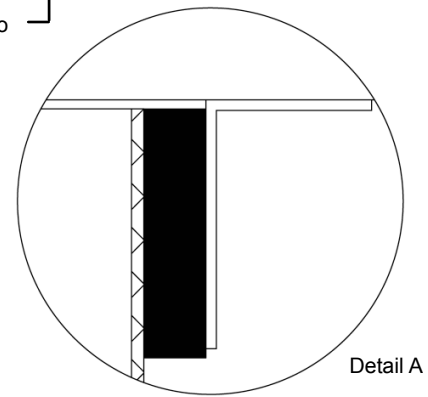

1. All dimensions are in inches and typical dimensions for supplied grilles only.
2. Check the dimensions for field supplied grilles because dimensions can be different.

**FIGURE 17 - UNIT-MOUNTED SUPPLY GRILLE INSTALLATION DIMENSIONS**

LD23556

**TABLE 6 - UNIT SUPPLY OPENING SIZES**

MODEL	HORIZONTAL OPENINGS					TOP OPENING
	SINGLE HORIZONTAL		DOUBLE HORIZONTAL		TRIPLE HORIZONTAL	
	NO TOP OPENING	TOP OPENING	NO TOP OPENING	TOP OPENING	NO TOP OPENING	
09	14W x 12H	14W x 6H	14W x 8H	N/A	N/A	12 x 8
12	14W x 14H	14W x 6H	14W x 10H	N/A	N/A	12 x 8
15	16W x 14H	14W x 6H	14W x 10H	N/A	14W x 8H	14 x 12
18	N/A	14W x 6H	14W x 12H	14W x 6H	14W x 10H	14 x 12
24	N/A	14W x 10H	16W x 14H	14W x 6H	14W x 10H	14 x 12
30	N/A	14W x 6H	20W x 14H	14W x 6H	16W x 12H	18 x 16
36	N/A	14W x 10H	N/A	14W x 6H	16W x 14H	18 x 16

**NOTES**

1. Manufacturer supplied supply grilles are double-deflection type.
2. Grilles for unequal airflow applications (for example, unit-mounted plus ducted supply) are provided with integral opposed-blade dampers.
3. All grilles are supplied in standard "Appliance White" painted finish.
4. Grilles ship loose for field installation upon completion of cabinet/ductwork/drywall installation.
5. Top opening size does not change. When combined with any other discharge arrangement, it is included in determining the horizontal opening grille size.
6. Openings marked 'N/A' result in face velocities outside the recommended 300-500 FPM range.
7. The Hi-Static Blower option or single horizontal discharge openings with unit-mounted supply grille are not recommended.

**TABLE 7 - UNIT SUPPLY FACE VELOCITY (FPM)**

MODEL	HORIZONTAL OPENINGS					TOP OPENING
	SINGLE HORIZONTAL		DOUBLE HORIZONTAL		TRIPLE HORIZONTAL	
	NO TOP OPENING	TOP OPENING	NO TOP OPENING	TOP OPENING	NO TOP OPENING	
09	291	272	219	N/A	N/A	510
12	316	344	221	N/A	N/A	645
15	354	314	283	N/A	236	471
18	N/A	391	294	294	235	587
24	N/A	397	273	364	291	729
30	N/A	416	276	339	269	538
36	N/A	410	N/A	385	261	610

**NOTES**

1. Tabulated face velocities do not account for supply grille free area factor. Face velocities at supply grille are higher depending on grille type.
2. Face velocities are based on the nominal rated cfm and in feet per minute (fpm).
3. Face velocities are calculated by taking the average across all openings. Tabulated top opening face velocity is only for units with single top opening and no horizontal openings.

## TOP MOUNTED FRESH AIR INTAKE

The optional fresh air intake provides a 4-inch round duct connection on top of the unit (see *Figure 22 on page 31* for right and left hand version). The fresh air discharges upstream of the direct expansion (DX) coil through the discharge collector box.



***Do not allow incoming air to bypass the DX coil, otherwise damage to unit may occur.***

Units can be selected with the fresh air opening located on top left or right hand side for ease of installation.

It is recommended that applications requiring 10% or more outdoor air utilize a pressurized fresh air system. Unit cabinet static pressure at the RA opening is not designed to draw 10% or more in passive fresh air systems.

The fresh air duct inside the unit is insulated to protect the unit from condensation in the event of high humidity air. However, excessively moist fresh air over prolonged periods can result in condensate inside the unit or closet.



***To avoid condensate developing inside ducts and equipment, it is recommended to pretreat fresh air with a high humidity ratio before it enters the unit assembly through energy recovery ventilators (ERV) or make-up air units.***

Unit comes with 4-1/4 inch RA sleeve. Front supply openings will come with 4-1/4 inch supply plaster flange.

### Top Mounted Fresh Air Intake with Motorized Damper

This includes the same features as the top mounted fresh air intake option with the addition of a motorized damper assembly inside the discharge collector box (see *Figure 22 on page 31*).

The damper assembly can be easily removed for servicing (see *Removing the Actuator on page 28*). The motorized damper assembly opens during FAN ON operation. See *Appendix on page 49* for electrical schematic. For other control options, please contact the factory.

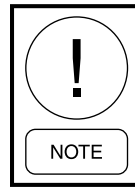

***During transportation, handling, or installation of the cabinet, excessive handling can cause the inner black plastic cover to come loose and jam the actuator, preventing the damper from opening.***

During start-up, check that the damper is opening when the unit fan is running. It can take 20 seconds to fully open. If the damper opens, the unit is operating as intended. If the damper fails to open, the cause is likely a loose cover preventing the actuator from rotating. Remove the actuator to service the damper.

### Removing the Actuator

1. Remove the damper plate:
  - a. Look underneath the top of the RA flange to observe the damper assembly.
  - b. Remove the seven fasteners holding the damper plate (see *Figure 18 on page 28*).
  - c. Drop down the plate and disconnect the quick-connect terminals from the harness.



Ld23557

**FIGURE 18 - DAMPER PLATE FASTENERS**

2. Remove the red cover from the actuator body (see *Figure 19 on page 28*).



LD23558

**FIGURE 19 - REMOVE THE RED COVER**

3. If the black cover is loose, position it in place and slide it back onto the actuator (see *Figure 20 on page 29*).



LD23559



LD23560

**FIGURE 20 - POSITION THE BLACK COVER**

4. Secure the red cover back over the actuator assembly.
5. Ensure the plastic tabs are secured to the metal body bracket.
6. Connect the quick-connect terminals and insert the damper assembly into the discharge collector box.
7. Fasten the assembly using the seven fasteners.

## SYSTEM FLUSHING AND CLEANING

After the piping system is complete, and before connecting the refrigeration chassis, flush and clean the risers. Flushing the risers ensures a proper start-up and a continued efficient operation of the system (see *Figure 21 on page 30*).

### Flushing the System

1. Ensure that the supply and return riser shut-off valves are closed for each unit.
2. Fill the water circulation system with clean water from the make-up water supply. Ensure the air vents are open during initial filling. Do not allow the system to overflow.
3. Close the air vents and start the circulating pump.
4. Ensure that all air is bled from the system by cracking each air vent.

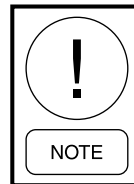

***Make-up water must be available in sufficient volume to replace the volume occupied by the air that is bled off.***

5. When all the air is vented and the water is circulating under pressure, check the entire system for leaks. Repair the leaks as required.
6. To raise the temperature to approximately 85.0°F, set the loop temperature controls. Visually check for any leaks that may have occurred due to the increased heat. Repair the leaks as required.
7. Open the drain at the lowest point in the system.

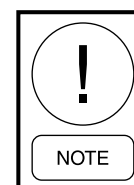

***The make-up water flow rate must be equal to the rate of drain bleed.***

8. Continue to bleed the system for at least two hours. If the water leaving the drain has not yet cleared, continue bleeding.
9. Completely drain the piping system.

## Cleaning the System

1. After the initial flushing, chemically clean the system. Repeat the method in *Flushing the System on page 29* to re-fill the system and circulate the cleaning solution.

It is recommended to use the services of a professional water treatment company for the type of solution to be used and the duration of the cleaning application.

2. Once the cleaning process is complete, shut off the circulating pump and completely drain the system.
3. Refill the system with clean water to prepare for refrigeration chassis connection and system start-up.



*It is recommended that a professional water treatment company perform ongoing maintenance of water loop including chemical analysis and flushing, if necessary. The water loop testing should be performed at intervals recommended by the professional water treatment consultant.*

*It is recommended that the water loop testing be performed at least once a year. Standard practice is once a month or quarterly.*

*The customer is responsible for completing adequate water loop maintenance over the lifespan of the units. Otherwise, damage to the units may occur.*

All Shut-Off Valves: Closed

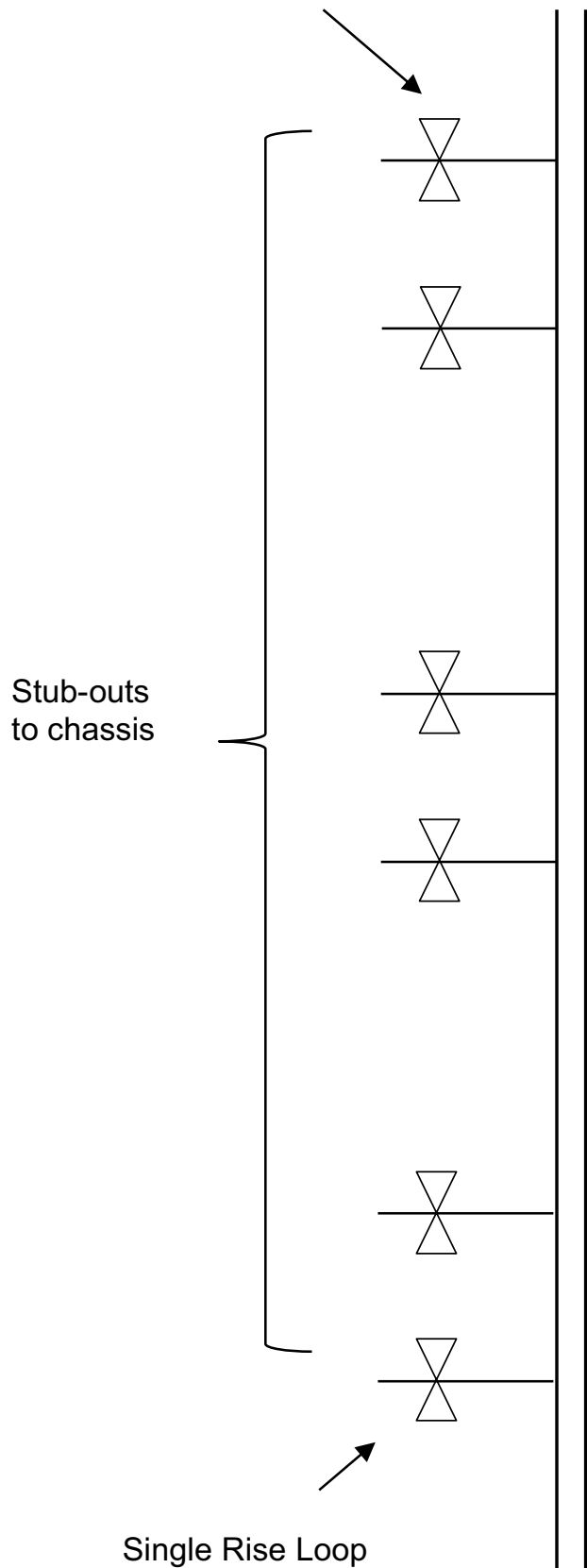

LD23570

**FIGURE 21 - SYSTEM FLUSHING AND CLEANING**

**TABLE 8 - CABINET DIMENSIONS**

MODEL	A	B	C
09-12	17	8	12
15-24	20	12	14
30-36	24	16	18

1. All measurements are in inches.
2. Optional Fresh Air option comes with 4-1/4 inch RA flange.
3. Optional front supply opening comes with 4-1/4 inch duct flange.
4. All other openings come with standard 1-inch duct flange.
5. Left and right hand versions shown.

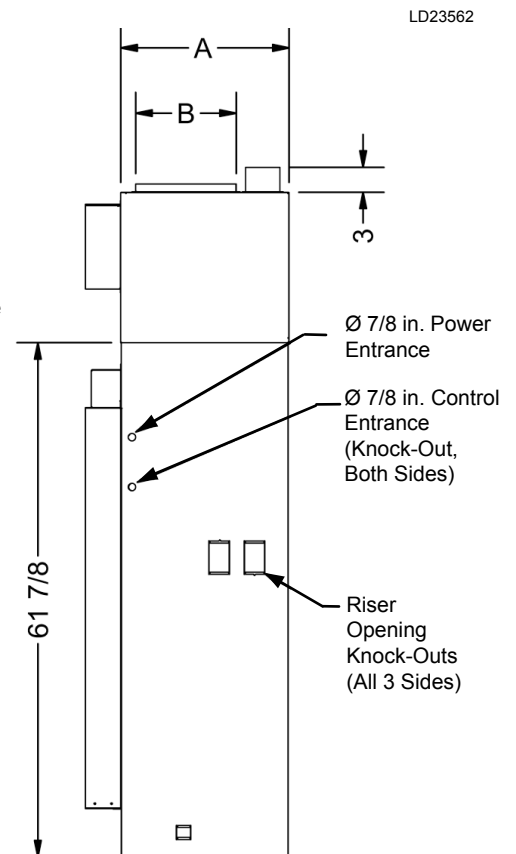
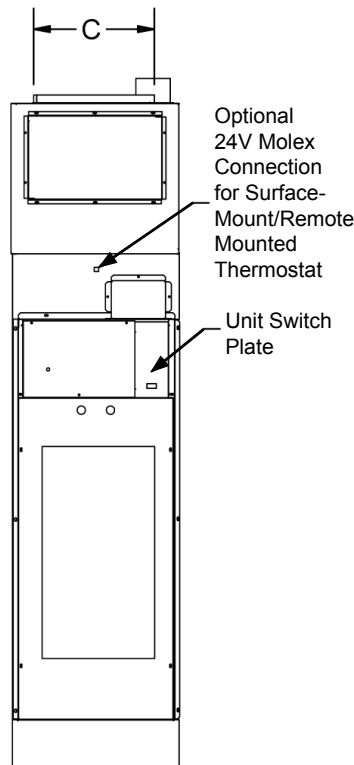
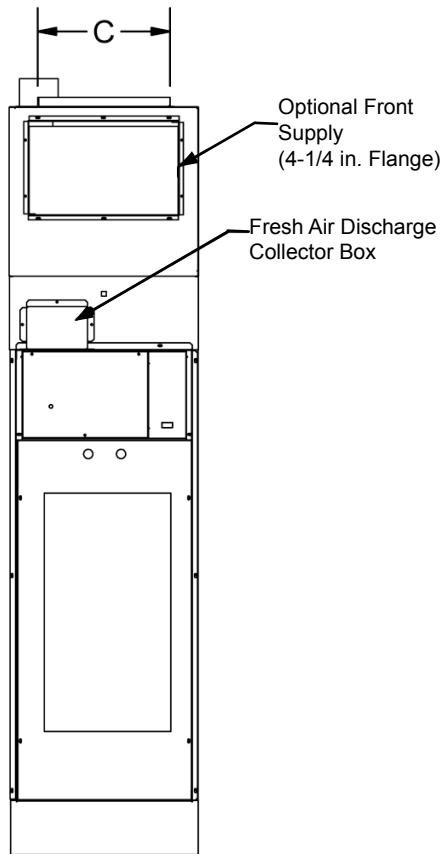
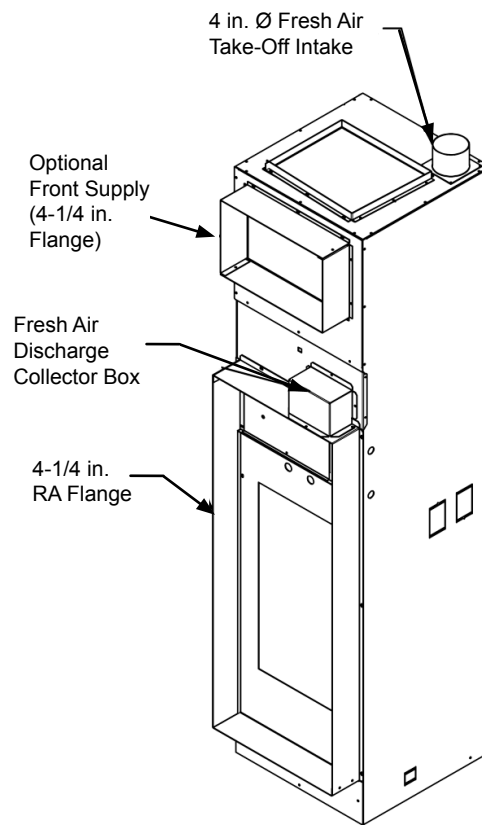
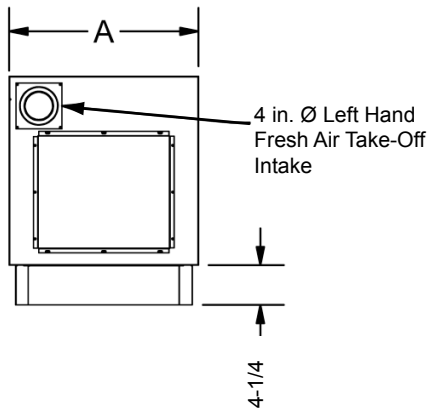

LD23562

LD23561

LD23563

**FIGURE 22 - FRESH AIR OPENING - LEFT HAND AND RIGHT HAND UNIT**



**CHASSIS INSTALLATION**

*Prior to installation of the refrigeration chassis and connection to the supply and return risers, the entire water loop system must be flushed and cleaned. See System Flushing and Cleaning on page 29.*



*Always use a backup wrench when installing hoses!*



*Protect chassis from physical damage, drywall dust, paint fumes, and construction contamination during installation.*

Remove the inner service panel from the cabinet and inspect the interior compartment for debris. Clear all debris and vacuum construction dust from the cabinet.

Locate the supply and return shut-off valves. Verify the following:

- The valves are closed.
- The type of hose kit fittings provided with the unit. Units shipped after June 2013 feature NPSH fittings (straight thread). Previous-generation hose kits are NPT type (tapered thread). For more information, see *Hoses on page 16*.



***HOSES MUST BE HAND TIGHTENED THEN FURTHER TIGHTENED NO MORE THAN 1/4 TURN. DO NOT APPLY EXCESSIVE FORCE!***



***ALWAYS USE A BACKUP WRENCH WHEN TIGHTENING HOSES TO VALVES! OTHERWISE, DAMAGE TO THE VALVE SOLDER JOINT CAN LEAD TO PROPERTY DAMAGE OR SERIOUS INJURY!***

**Installing Units with JIC Style (37° Flare) Valve Connection and Hoses**

Factory supplied JIC flexible connection hoses come with a tapered end connection. No thread sealing tape should be required. Connect the hoses to the JIC fitting on the shut-off valves. Always use a backup wrench when tightening the hose to the valve fitting. Enable the hoses to hang free inside the cabinet.

Slide the chassis into place using the following steps. No thread sealant should be required.

1. Thread the swivel adapters into the JIC fittings projecting through the top of the compressor compartment access cover. To prevent twisting of the copper water piping in the chassis assembly, always use a backup wrench.

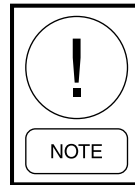

***To minimize the possibility of damage to the chassis or cabinet, for maximum ease of installation, the use of a two-wheeled dolly is strongly recommended.***

2. Lift the front of the chassis.

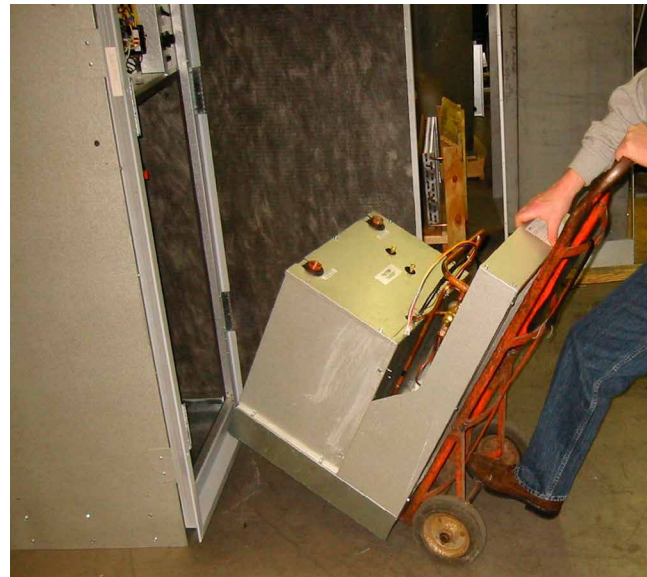

LD23564

**FIGURE 23 - LIFT THE CHASSIS FRONT**

***Do not make contact with the finned coil face. Damage to the fins will result.***



3. Align the chassis with the opening of the cabinet. Tilt the chassis sufficiently for the base of the chassis to clear the mounting rails on the cabinet drain pan.



LD23565

**FIGURE 24 - TILT THE CHASSIS**

4. Insert the chassis midway into the opening of the cabinet. Lower the rear of the chassis until the base of the chassis touches the formed mounting rails in the cabinet drain pan.



LD23566

**FIGURE 25 - INSERT THE CHASSIS**



***Before fully inserting chassis, ensure wiring harness and or water hoses will not be pinched.***

5. Pivot the chassis base on the front edge of the drain pan rails. Before fully inserting the chassis, ensure the wiring harness or water hoses cannot be pinched between the chassis and cabinet.



LD23567

**FIGURE 26 - PIVOT THE CHASSIS**



***Do not apply excessive force when sliding chassis into cabinet!***

6. Slide the chassis into the cabinet until at least 3/4 of the depth of the chassis is supported. The chassis should slide easily on the drain pan rails. Do not apply excessive force! Ensure that the chassis does not tip forward before removing the dolly.

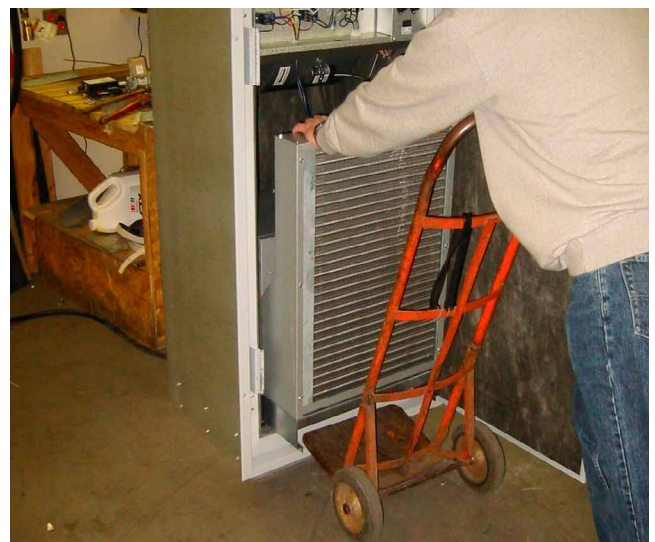

LD23568

**FIGURE 27 - SLIDE THE CHASSIS**



**To avoid damage from clogged coil surfaces, plugged motor ventilation openings, and potential unit failure, DO NOT operate unit without complete enclosure, supply grille, RA panel, and filter in place.**

7. Connect the supply hose to the chassis 'Water In' and supply riser shut-off. Connect the return hose to the chassis only and point the other end of the hose into the cabinet drain pan.
8. To allow water to fill and circulate through the chassis system, open the supply riser shut-off slightly.
9. Observe the stream of leaving water. Once a solid stream of water is established and there is no air remaining in the system, close the supply riser shut-off and connect the return hose to the riser shut-off. Ensure the hoses cannot be pinched before sliding the chassis into place.



**When bleeding air from chassis system, ensure that return hose is inserted in cabinet drain pan properly. Do not fully open the supply riser. A steady stream of water is sufficient to force air through the chassis.**

10. Without touching the flanges on either side, ensure the chassis' alignment in the cabinet is centered in the cabinet opening.



LD23569

**FIGURE 28 - CHECK THE CHASSIS ALIGNMENT**

11. To complete the electrical connections to the chassis, use the two quick-connect mating plugs. The unit-mounted plug ends are located on the bottom of the control box.
12. Remove the shipping cover from the face of the air-to-refrigerant coil.
13. Install the inner service panel and check that the foam gasket seal between the panel and the chassis is slightly compressed.
14. If necessary, pull the chassis forward slightly. This ensures an adequate seal between the chassis and the service panel.
15. Install the air filter onto the face of the service panel. Slide the filter upward into the top-retaining clip until the bottom of the filter can be dropped onto the lower clip.
16. Install the service panel.
17. Install the RA panel into the drywall opening if not already installed. See *Acoustic RA Panel on page 21*. Secure the panel into the drywall with six screws.

## SECTION 2 - OPERATION

Once the installation is complete and the system is cleaned and flushed, begin unit start-up. Open the supply and return shut-off valves at each unit, refill the system, and bleed off all remaining air.

### PRE START-UP CHECKLIST

Before energizing the unit, perform the following checks and complete the Vertical Stacked Heat Pump Start-Up and Performance Checklist (*Form 145.18-CLI*) in compliance with warranty requirements.

- The high voltage power supply is correct and in accordance with the nameplate ratings.
- The field wiring and circuit protection are the correct size.
- The unit is electrically grounded.
- The low voltage control wiring is correct per the unit wiring diagram.
- There is vibration isolation (for example, by a unit isolation pad or flexible hoses).
- The low-side or high-side pressure temperature caps are secure and in place.
- All the unit access panels are secure and in place.
- The thermostat is in the OFF position.
- The water flow is established and circulating through all the units.
- The ductwork (if required) is correctly sized, run, taped, and insulated.
- The indoor blower turns freely without rubbing.
- Clean, properly-sized air filters are in place.
- The condensate drain pipe is firmly secured to both the drain riser and the drain pan stub.

### INITIAL START-UP



*During installation, testing, servicing, and troubleshooting of this product, it may be necessary to work with live electrical components. Failure to follow all electrical safety precautions when exposed to live electrical components could result in serious injury or death.*

1. Close the disconnect switches on all units to provide line power.
2. Set the thermostat to the highest temperature setting.
3. Set the thermostat system switch to COOL and the fan control switch to AUTO. The compressor should NOT run.
4. Reduce the temperature control setting until the compressor and supply fan energize, with the following results:
  - Water temperature leaving the heat exchanger is warmer than the entering water temperature (approx. 9.0–12.0°F).
  - The blower operation is smooth.
  - The compressor and blower amps are within the nameplate data values.
  - The suction line is cool with no frost observed in the refrigerant circuit.
5. Turn the thermostat switch to the OFF position. The compressor and fan stop running and the reversing valve de-energizes.
6. To allow for pressure equalization, leave the unit off for approximately five minutes.
7. Turn the thermostat to the lowest setting.
8. Set the thermostat system switch to the HEAT position. The compressor should NOT run.
9. Adjust the temperature setting upward until the compressor and supply fan energize, with the following results after several minutes:
  - Warm air is detected at the supply register.
  - The water temperature decreases by approximately 5.0–9.0°F across the heat exchanger.
  - The blower and compressor operations are smooth with no frost observed in the refrigerant circuit.

10. Set the thermostat to maintain the space temperature.
11. Check all water connections for any leaks, including the condensate drain hose connections.

**SYSTEM LOOP TEMPERATURES**

Loop temperatures affect unit performance, power consumption (efficiency), maintenance and reliability, and noise levels. High entering water temperatures (EWT) in cooling mode above the rated conditions of 86.0°F EWT increase the power consumption and increase the compressor noise levels. A sustained operation above 100.0°F EWT can increase maintenance costs. Increased compressor noise can affect the occupancy comfort. The unit is designed to operate up to 110.0°F EWT for intermittent periods when high load conditions elevate the system loop temperatures.

It is not recommended to set the system loop temperatures at 110.0°F in case high load conditions cause the supply loop temperatures to exceed 110.0°F EWT. The unit sound performance can be negatively impacted at a high EWT.

During heating season, the maximum operating loop temperature is 90.0°F EWT. For optimal unit performance, it is recommended to maintain the system loop temperatures at or above the rated conditions of 68.0°F EWT. Minimum loop temperature is 40.0°F. Lower loop temperatures result in exceeding the pump rating for minimum fluid temperature.

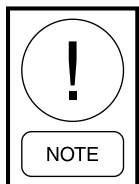

***High system loop temperatures may negatively affect unit performance, efficiency, maintenance and reliability, and noise levels.***



***Minimum water temperature for Taco Load Match circulating pump is 40.0°F. Do not exceed minimum rating as this will result in damages to pump.***



***Maximum operating pressure for Taco Load Match circulating pump is 200 psi (1379kPa). Do not exceed maximum rating as this will result in damages to pump.***



***Taco Load Match cast iron circulating pump is to be used for closed loop systems. Bronze or stainless steel circulators are to be used for open loop, fresh water, or potable water systems.***

**TABLE 9 - OPERATING LIMITS**

	COOLING	HEATING
Minimum Entering Water	40.0°F	50.0°F
Maximum Entering Water	110.0°F	90.0°F

**TABLE 10 - NOMINAL OPERATING GPM**

CHASSIS	PUMP HP	PUMP FLA (208-230/1)	PUMP FLOW RATE (WITH STRAINER)	PUMP FLOW RATE (NO STRAINER)
VSCS09	1/40	0.36	1.8 gpm	1.9 gpm
VSCS12	1/25	0.46	2.7 gpm	2.8 gpm
VSCS15	1/25	0.46	2.8 gpm	2.9 gpm
VSCS18	1/25	0.46	3.0 gpm	3.2 gpm
VSCS24	1/25	0.46	5.4 gpm	5.6 gpm
VSCS30	1/8	0.73	7.0 gpm	7.2 gpm
VSCS36	1/8	0.73	7.9 gpm	8.1 gpm

**NOTES**

1. Published GPM rates are nominal values taken at 68.0°F, standard hose lengths, and chassis piping configuration. Actual flow rates are affected by water temperature and possible field alterations to the chassis piping system.
2. Limit the stub-out extensions on the satellite side riser to a maximum of 24 inches and no 90° elbows.
3. Adding excessive pressure drop by means of field alterations to the piping system results in lower water flow of the pump.



### FAN SPEED ADJUSTMENT

Multi-speed direct drive motors are used in all units as standard. PSC fan motors have a minimum of three selectable speeds and EC motors (ECMs) have five speeds. However, only two speeds are recommended and selected for use.

Optional ECMs increase operating efficiency by consuming fewer watts than standard PSC motors. Motors are factory programmed and cannot be reprogrammed in the field. Each motor contains five low voltage speed taps. Two speed taps are used as standard.

Blower speed taps are factory set for optimum heating and cooling airflow ranges. For factory blower speed settings and minimum operating airflow, see *Table 11 on page 38*, *Table 12 on page 38*, *Table 13 on page 39*, *Table 14 on page 39*, and *Table 15 on page 40*.

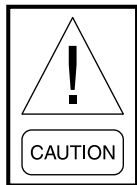

***Operating unit below the minimum airflow may result poor heating/cooling performance and periodic unit lockout.***

A unit-mounted two-speed fan switch located on the electrical box cover enables the fan speed to switch from LOW and HIGH. This enables the fan speed to meet site conditions such as increased ductwork static pressure or the use of higher efficient filters.

Perform a test run on the installed system to ensure an operation with sufficient heating and cooling airflow. Excessive ductwork static pressure will result in an improper volume of airflow. High airflow volumes will result in elevated noise levels and may affect occupancy comfort.



***Lock all electrical power supply switches in the OFF position before servicing the unit. Failure to disconnect power supply may result in electrical shock or even death.***



LD23575

**FIGURE 29 - CHASSIS WITH PUMP**

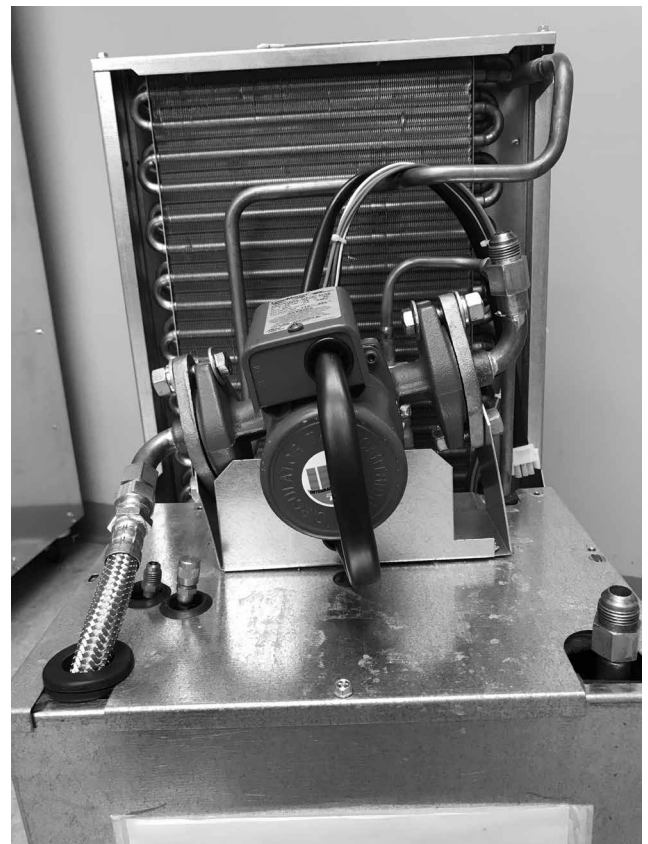

LD23576

**FIGURE 30 - CHASSIS WITH PUMP (DETAIL)**

TABLE 11 - PSC STANDARD BLOWER PERFORMANCE (CFM)

UNIT SIZE	MOTOR SPEED	RATED CFM	MIN. CFM	EXTERNAL STATIC PRESSURE (IN W.G.)															
				0.0	0.05	0.1	0.15	0.2	0.25	0.3	0.35	0.4	0.45	0.5					
09	HIGH	340	220	340	330	320	310	300	285	270	255	240	225	-	-	-	-		
	LOW			255	250	240	230	220	210	-	-	-	-	-	-	-	-	-	
12	HIGH	430	290	445	435	425	415	400	385	370	355	340	320	295	-	-	-		
	LOW			350	345	335	325	315	305	290	-	-	-	-	-	-	-	-	
15	HIGH	550	335	580	570	560	550	535	520	505	485	465	445	425	-	-	-		
	LOW			385	380	375	370	365	355	345	335	-	-	-	-	-	-	-	
18	HIGH	685	430	700	690	675	660	635	615	595	575	550	525	495	-	-	-		
	LOW			450	445	440	435	430	425	-	-	-	-	-	-	-	-	-	
24	HIGH	850	575	880	855	835	815	795	770	740	710	680	650	615	-	-	-		
	LOW			715	710	705	690	670	650	630	605	580	-	-	-	-	-	-	
30	HIGH	1075	700	1115	1100	1075	1050	1020	990	960	930	895	850	800	-	-	-		
	LOW			965	960	950	935	915	895	870	840	810	780	745	-	-	-	-	
36	HIGH	1220	840	1230	1200	1170	1140	1110	1075	1040	1000	960	915	870	-	-	-		
	LOW			1115	1100	1075	1050	1020	990	960	930	895	855	805	-	-	-	-	

TABLE 12 - PSC HIGH STATIC BLOWER PERFORMANCE (CFM)

UNIT SIZE	MOTOR SPEED	RATED CFM	MIN. CFM	EXTERNAL STATIC PRESSURE (IN W.G.)																
				0.0	0.05	0.1	0.15	0.2	0.25	0.3	0.35	0.4	0.45	0.5	0.55	0.6	0.65	0.7	0.75	0.8
09	HIGH	340	220	375	370	360	350	340	330	315	300	285	265	245	220	-	-	-	-	-
	LOW			330	320	310	300	290	280	270	255	240	225	-	-	-	-	-	-	-
12	HIGH	430	290	485	475	465	455	440	425	410	395	380	360	340	315	-	-	-	-	-
	LOW			390	385	380	370	360	350	335	320	305	-	-	-	-	-	-	-	-
15	HIGH	550	335	665	650	635	615	595	575	555	540	520	500	475	450	420	395	370	340	-
	LOW			580	570	560	550	535	520	505	485	465	445	425	400	375	350	-	-	-
18	HIGH	685	430	750	735	715	695	675	655	630	605	580	555	525	495	465	435	-	-	-
	LOW			670	655	640	625	605	585	560	535	510	485	460	435	-	-	-	-	-
24	HIGH	850	575	990	970	950	930	910	890	865	845	820	795	770	740	710	680	650	615	575
	LOW			795	785	775	760	745	730	715	695	675	655	630	605	580	550	525	495	460
30	HIGH	1075	700	1180	1170	1160	1145	1130	1110	1090	1070	1050	1025	1000	970	940	910	875	840	800
	LOW			985	980	975	970	960	950	940	935	920	905	895	885	875	850	825	795	765
36	HIGH	1220	840	1340	1320	1295	1270	1245	1220	1190	1160	1130	1100	1070	1040	1010	980	945	910	870
	LOW			1180	1170	1160	1145	1130	1110	1090	1070	1050	1025	1000	970	940	910	875	840	800

TABLE 13 - ECM STANDARD BLOWER PERFORMANCE (CFM)

UNIT SIZE	MOTOR SPEED	RATED CFM	MIN. CFM	EXTERNAL STATIC PRESSURE (IN W.G.)																
				0.0	0.05	0.1	0.15	0.2	0.25	0.3	0.35	0.4	0.45	0.5	0.55	0.6	0.65	0.7	0.75	
09	HIGH	340	220	342	317	292	276	259	247	236	228	220	214	207						
	LOW			278	252	226	212	198	189	180	-	-	-	-	-	-	-	-	-	-
12	HIGH	430	290	463	431	399	378	356	340	324	317	310	299	289						
	LOW			342	317	292	276	259	247	236	-	-	-	-	-	-	-	-	-	-
15	HIGH	550	335	600	567	534	500	466	445	424	396	367	340	312						
	LOW			495	447	399	372	346	307	268	-	-	-	-	-	-	-	-	-	-
18	HIGH	685	430	760	726	693	667	642	615	587	574	561	529	497						
	LOW			600	567	534	500	466	445	424	396	-	-	-	-	-	-	-	-	-
24	HIGH	850	575	891	863	835	809	784	757	730	689	648	601	554						
	LOW			760	726	693	667	642	615	587	574	-	-	-	-	-	-	-	-	-
30	HIGH	1075	700	1131	1105	1079	1058	1037	1016	994	972	949	934	918						
	LOW			918	894	870	852	835	808	781	762	743	718	-	-	-	-	-	-	-
36	HIGH	1220	840	1265	1235	1206	1184	1163	1141	1118	1085	1051	1008	965						
	LOW			1065	1037	1009	987	965	949	934	910	886	874	861	-	-	-	-	-	-

TABLE 14 - ECM HIGH STATIC BLOWER PERFORMANCE (CFM)

UNIT SIZE	MOTOR SPEED	RATED CFM	MIN. CFM	EXTERNAL STATIC PRESSURE (IN W.G.)																				
				0.0	0.05	0.1	0.15	0.2	0.25	0.3	0.35	0.4	0.45	0.5	0.55	0.6	0.65	0.7	0.75					
09	HIGH	340	220	411	382	354	334	315	300	286	279	272	263	254	242	231	220	-	-	-				
	LOW			342	317	292	276	259	247	236	228	220	-	-	-	-	-	-	-	-	-			
12	HIGH	430	290	554	529	504	477	451	430	408	393	378	360	341	330	319	300	-	-	-				
	LOW			463	431	399	378	356	340	324	317	310	299	290	-	-	-	-	-	-	-			
15	HIGH	550	335	659	623	587	564	541	511	482	462	441	419	397	372	346	320	-	-	-				
	LOW			600	567	534	500	466	445	424	396	367	340	312	-	-	-	-	-	-	-			
18	HIGH	685	430	891	863	835	809	784	757	730	689	648	601	554	518	482	446	408	-	-				
	LOW			760	726	693	667	642	615	587	574	561	529	497	469	441	412	-	-	-	-			
24	HIGH	850	575	1002	971	940	912	883	854	826	800	774	749	724	698	671	643	615	586	-				
	LOW			866	827	789	762	735	708	682	659	636	612	587	571	-	-	-	-	-	-			
30	HIGH	1075	700	1265	1235	1206	1184	1163	1141	1118	1085	1051	1008	965	913	861	808	756	701	-				
	LOW			1065	1037	1009	987	965	949	934	910	886	874	861	839	818	-	-	-	-	-			
36	HIGH	1220	840	1462	1418	1375	1331	1287	1241	1194	1153	1112	1053	994	964	934	903	872	840	-				
	LOW			1265	1235	1206	1184	1163	1141	1118	1085	1051	1008	965	913	861	-	-	-	-	-			

**TABLE 15 - ECM BLOWER PERFORMANCE - ALL SPEED TAPS (CFM)**

UNIT SIZE	MOTOR SPEED	RATED CFM	MIN. CFM	EXTERNAL STATIC PRESSURE (IN W.G.)																							
				0.0	0.05	0.1	0.15	0.2	0.25	0.3	0.35	0.4	0.45	0.5	0.55	0.6	0.65	0.7	0.75								
09	3	340	180	278	252	226	212	198	189	180	-	-	-	-	-	-	-	-	-	-							
				342	317	292	276	259	247	236	228	220	214	207	-	-	-	-	-	-	-						
				411	382	354	334	315	300	286	279	272	263	254	242	231	220	-	-	-	-	-					
				463	431	399	378	356	340	324	317	310	299	290	-	-	-	-	-	-	-	-	-				
				554	529	504	477	451	430	408	393	378	360	341	330	319	300	-	-	-	-	-	-	-			
12	3	430	236	278	252	226	212	198	189	180	-	-	-	-	-	-	-	-	-	-	-						
				342	317	292	276	259	247	236	-	-	-	-	-	-	-	-	-	-	-	-	-				
				411	382	354	334	315	300	286	279	272	263	254	242	231	220	-	-	-	-	-	-	-			
				463	431	399	378	356	340	324	317	310	299	289	-	-	-	-	-	-	-	-	-	-	-		
				554	529	504	477	451	430	408	393	378	360	341	330	319	300	-	-	-	-	-	-	-	-		
15	3	550	268	495	447	399	372	346	307	268	-	-	-	-	-	-	-	-	-	-	-	-	-				
				600	567	534	500	466	445	424	396	367	340	312	-	-	-	-	-	-	-	-	-	-	-		
				659	623	587	564	541	511	482	462	441	419	397	372	346	320	-	-	-	-	-	-	-	-	-	
				760	726	693	667	642	615	587	574	561	529	497	469	441	412	-	-	-	-	-	-	-	-	-	
				891	863	835	809	784	757	730	689	648	601	554	518	482	446	408	-	-	-	-	-	-	-	-	-
18	3	685	396	495	447	399	372	346	307	268	-	-	-	-	-	-	-	-	-	-	-	-	-	-			
				600	567	534	500	466	445	424	396	367	340	312	-	-	-	-	-	-	-	-	-	-	-		
				659	623	587	564	541	511	482	462	441	419	397	372	346	320	-	-	-	-	-	-	-	-	-	
				760	726	693	667	642	615	587	574	561	529	497	469	441	412	-	-	-	-	-	-	-	-	-	
				891	863	835	809	784	757	730	689	648	601	554	518	482	446	408	-	-	-	-	-	-	-	-	-
24	3	850	574	659	623	587	564	541	511	482	462	441	419	397	372	346	320	-	-	-	-	-	-	-			
				760	726	693	667	642	615	587	574	561	529	497	469	441	412	-	-	-	-	-	-	-	-		
				866	827	789	762	735	708	682	659	636	612	587	571	-	-	-	-	-	-	-	-	-	-	-	
				891	863	835	809	784	757	730	689	648	601	554	518	482	446	408	-	-	-	-	-	-	-	-	
				1002	971	940	912	883	854	826	800	774	749	724	698	671	643	615	586	-	-	-	-	-	-	-	-
30	3	1075	718	918	894	870	852	835	808	781	762	743	718	-	-	-	-	-	-	-	-	-	-	-			
				1065	1037	1009	987	965	949	934	910	886	874	861	-	-	-	-	-	-	-	-	-	-	-	-	
				1131	1105	1079	1058	1037	1016	994	972	949	934	918	-	-	-	-	-	-	-	-	-	-	-	-	
				1265	1235	1206	1184	1163	1141	1118	1085	1051	1008	965	913	861	808	756	701	-	-	-	-	-	-	-	-
				1462	1418	1375	1331	1287	1241	1194	1153	1112	1053	994	964	934	903	872	840	-	-	-	-	-	-	-	-
36	3	1220	861	918	894	870	852	835	808	781	762	743	718	-	-	-	-	-	-	-	-	-	-	-			
				1065	1037	1009	987	965	949	934	910	886	874	861	-	-	-	-	-	-	-	-	-	-	-		
				1131	1105	1079	1058	1037	1016	994	972	949	934	918	-	-	-	-	-	-	-	-	-	-	-	-	
				1265	1235	1206	1184	1163	1141	1118	1085	1051	1008	965	913	861	808	756	701	-	-	-	-	-	-	-	
				1462	1418	1375	1331	1287	1241	1194	1153	1112	1053	994	964	934	903	872	840	-	-	-	-	-	-	-	-

All airflow ratings are at lowest voltage rating of dual rating (for example, 208 volt).  
Airflow ratings include resistance of wet coil and clean air filters.



**ELECTRICAL DATA**

**TABLE 16 - PSC - STANDARD BLOWER**

UNIT SIZE	SUPPLY VOLTAGE	COMPRESSOR				BLOWER		PUMP	MIN. CCT. AMPACITY	MAX FUSE/ CCT. BKR. AMP
		QTY	RLA	LRA	HP	FLA	FLA			
09	208-230/1/60	1	@	3.7	22.0	0.10	0.8	0.4	5.79	15
12	208-230/1/60	1	@	4.7	25.0	0.10	0.8	0.5	7.14	15
15	208-230/1/60	1	@	5.6	29.0	0.17	1.2	0.5	8.66	15
18	208-230/1/60	1	@	9.0	48.0	0.17	1.2	0.5	12.91	20
24	208-230/1/60	1	@	12.8	58.3	0.25	1.5	0.5	17.96	30
30	208-230/1/60	1	@	14.1	73.0	0.33	2.6	0.7	20.96	35
36	208-230/1/60	1	@	16.7	79.0	0.50	3.2	0.7	24.81	40

**TABLE 17 - PSC - OPTIONAL HI-STATIC BLOWER**

UNIT SIZE	SUPPLY VOLTAGE	COMPRESSOR				BLOWER		PUMP	MIN. CCT. AMPACITY	MAX FUSE/ CCT. BKR. AMP
		QTY	RLA	LRA	HP	FLA	FLA			
09	208-230/1/60	1	@	3.7	22.0	0.10	0.8	0.4	5.79	15
12	208-230/1/60	1	@	4.7	25.0	0.17	1.2	0.5	7.54	15
15	208-230/1/60	1	@	5.6	29.0	0.17	1.2	0.5	8.66	15
18	208-230/1/60	1	@	9.0	48.0	0.25	1.5	0.5	13.21	20
24	208-230/1/60	1	@	12.8	58.3	0.33	2.6	0.5	19.06	30
30	208-230/1/60	1	@	14.1	73.0	0.33	2.6	0.7	20.96	35
36	208-230/1/60	1	@	16.7	79.0	0.50	3.2	0.7	24.81	40

**TABLE 18 - PSC - STANDARD BLOWER (265 VOLT)**

UNIT SIZE	SUPPLY VOLTAGE	COMPRESSOR				BLOWER		PUMP	MIN. CCT. AMPACITY	MAX FUSE/ CCT. BKR. AMP
		QTY	RLA	LRA	HP	FLA	FLA			
09	265/1/60	1	@	3.4	23.0	0.10	0.7	0.2	5.17	15
12	265/1/60	1	@	4.8	26.3	0.10	0.7	0.3	7.00	15
15	265/1/60	1	@	5.0	28.0	0.17	0.8	0.3	7.35	15
18	265/1/60	1	@	7.1	43.0	0.17	0.8	0.3	9.99	15
24	265/1/60	1	@	9.6	54.0	0.25	1.3	0.3	13.61	20
30	265/1/60	1	@	11.2	60.0	0.33	1.9	0.6	16.54	25
36	265/1/60	1	@	13.5	72.0	0.50	2.2	0.6	19.72	30

**TABLE 19 - PSC - OPTIONAL HI-STATIC BLOWER (265 VOLT)**

UNIT SIZE	SUPPLY VOLTAGE	COMPRESSOR				BLOWER		PUMP	MIN. CCT. AMPACITY	MAX FUSE/ CCT. BKR. AMP
		QTY	RLA	LRA	HP	FLA	FLA			
09	265/1/60	1	@	3.4	23.0	0.10	0.7	0.2	5.17	15
12	265/1/60	1	@	4.8	26.3	0.17	0.8	0.3	7.10	15
15	265/1/60	1	@	5.0	28.0	0.25	1.3	0.3	7.85	15
18	265/1/60	1	@	7.1	43.0	0.25	1.3	0.3	10.49	15
24	265/1/60	1	@	9.6	54.0	0.33	1.9	0.3	14.21	20
30	265/1/60	1	@	11.2	60.0	0.33	1.9	0.6	16.54	25
36	265/1/60	1	@	13.5	72.0	0.50	2.2	0.6	19.72	30

**2**

**TABLE 20 - ECM - STANDARD BLOWER**

UNIT SIZE	SUPPLY VOLTAGE	COMPRESSOR				BLOWER		PUMP	MIN. CCT. AMPACITY	MAX FUSE/ CCT. BKR. AMP
		QTY	RLA	LRA	HP	FLA	FLA			
09	208-230/1/60	1	@	3.7	22.0	0.33	1.0	0.4	5.98	15
12	208-230/1/60	1	@	4.7	25.0	0.33	1.0	0.5	7.34	15
15	208-230/1/60	1	@	5.6	29.0	0.33	2.0	0.5	9.46	15
18	208-230/1/60	1	@	9.0	48.0	0.33	2.0	0.5	13.71	20
24	208-230/1/60	1	@	12.8	58.3	0.33	2.0	0.5	18.46	30
30	208-230/1/60	1	@	14.1	73.0	0.50	2.4	0.7	20.76	30
36	208-230/1/60	1	@	16.7	79.0	0.50	2.4	0.7	24.01	40

**TABLE 21 - ECM - OPTIONAL HI-STATIC BLOWER**

UNIT SIZE	SUPPLY VOLTAGE	COMPRESSOR				BLOWER		PUMP	MIN. CCT. AMPACITY	MAX FUSE/ CCT. BKR. AMP
		QTY	RLA	LRA	HP	FLA	FLA			
09	208-230/1/60	1	@	3.7	22.0	0.33	1.0	0.4	5.98	15
12	208-230/1/60	1	@	4.7	25.0	0.33	1.0	0.5	7.34	15
15	208-230/1/60	1	@	5.6	29.0	0.33	2.0	0.5	9.46	15
18	208-230/1/60	1	@	9.0	48.0	0.33	2.0	0.5	13.71	20
24	208-230/1/60	1	@	12.8	58.3	0.33	2.0	0.5	18.46	30
30	208-230/1/60	1	@	14.1	73.0	0.50	2.4	0.7	20.76	30
36	208-230/1/60	1	@	16.7	79.0	0.50	2.4	0.7	24.01	40

**TABLE 22 - ECM - STANDARD BLOWER (265 VOLT)**

UNIT SIZE	SUPPLY VOLTAGE	COMPRESSOR				BLOWER		PUMP	MIN. CCT. AMPACITY	MAX FUSE/ CCT. BKR. AMP
		QTY	RLA	LRA	HP	FLA	FLA			
09	265/1/60	1	@	3.4	23.0	0.33	1.0	0.2	5.47	15
12	265/1/60	1	@	4.8	26.3	0.33	1.0	0.3	7.30	15
15	265/1/60	1	@	5.0	28.0	0.33	2.0	0.3	8.55	15
18	265/1/60	1	@	7.1	43.0	0.33	2.0	0.3	11.19	15
24	265/1/60	1	@	9.6	54.0	0.33	2.0	0.3	14.31	20
30	265/1/60	1	@	11.2	60.0	0.50	2.4	0.6	17.04	25
36	265/1/60	1	@	13.5	72.0	0.50	2.4	0.6	19.92	30

**TABLE 23 - ECM - OPTIONAL HI-STATIC BLOWER (265 VOLT)**

UNIT SIZE	SUPPLY VOLTAGE	COMPRESSOR				BLOWER		PUMP	MIN. CCT. AMPACITY	MAX FUSE/ CCT. BKR. AMP
		QTY	RLA	LRA	HP	FLA	FLA			
09	265/1/60	1	@	3.4	23.0	0.33	1.0	0.2	5.47	15
12	265/1/60	1	@	4.8	26.3	0.33	1.0	0.3	7.30	15
15	265/1/60	1	@	5.0	28.0	0.33	2.0	0.3	8.55	15
18	265/1/60	1	@	7.1	43.0	0.33	2.0	0.3	11.19	15
24	265/1/60	1	@	9.6	54.0	0.33	2.0	0.3	14.31	20
30	265/1/60	1	@	11.2	60.0	0.50	2.4	0.6	17.04	25
36	265/1/60	1	@	13.5	72.0	0.50	2.4	0.6	19.92	30

## UNIT CONTROLS

The control system microprocessor board is specifically designed for water source heat pump operation. The control system interfaces with a conventional type thermostat.

- The unit is complete with a self-contained low-voltage control circuit.
- The unit incorporates a lockout circuit. The lockout circuit provides a reset capability from a hard lockout at the space thermostat or base unit if any of the following standard safety devices trip and shut off the compressor.
  - Loss-of-charge/low pressure limit switch
  - High pressure limit switch
  - Freeze protection thermostat, unit shutdown on low leaving water temperature
  - Condensate overflow protection switch
- The unit operates with conventional thermostat designs and has a low voltage terminal strip for easy hook-up.
- The unit control board has an onboard diagnostics and fault code display.
- The standard controls include an anti-short cycle and low voltage protection.
- The control board monitors each refrigerant safety switch independently.
- The control board has a random start feature
- The control board retains the last five fault codes in nonvolatile memory that are not lost in the event of a power loss.

## Sequence of Operation

The room thermostat makes a circuit between R & Y1 for cooling.

A call passes to the unit microprocessor control that determines whether the requested operation is available and, if so, which components to energize.

For heating, the room thermostat makes a circuit between R & W1. The microprocessor control energizes the compressor and fan, enabling the unit to run in heating mode.

If at any time there is a call for both heating and cooling, the heating operation is performed. Heating always takes priority. If operating, the cooling system halts and ends the call for cooling.

## Continuous Blower

With the room thermostat fan switch set to AUTO and the system switch is set to either AUTO or HEAT, the blower energizes whenever a cooling or heating operation is requested. The blower energizes after any specified delay associated with the operation.

The indoor blower energizes for a minimum runtime of 30 seconds. Additionally, the indoor blower delays for 10 seconds between operations.

When the room thermostat calls for cooling, the low voltage control circuit completes from R to Y1 and G. The compressor and fan motor energize. After completing the specified fan on delay for cooling, the microprocessor control energizes the blower motor.

Once the room thermostat has been met, it de-energizes Y1. If the compressor meets its minimum runtime, the compressor and fan de-energize. Otherwise, the unit operates the cooling system until the minimum runtime for the compressor completes. After the compressor de-energizes and the time for fan off delay elapses, the blower stops.

To be available, a compressor must not be locked out because of a high pressure limit switch, low pressure limit switch, a condensate overflow switch, or a freeze-stat trip. The anti-short cycle delay (ASCD) must elapse.

## Safety Control Reset

All VSCS heat pumps include the following:

- A high pressure protection switch
- A low pressure control switch
- A low water temperature protection switch
- A condensate overflow switch (to prevent compressor operation during abnormal conditions)

If any of these safety devices activate, a lockout relay circuit engages. The circuit interrupts the heating and cooling operation even if the control contacts automatically re-close.

This microprocessor-driven lockout circuit must be manually reset. Reset by momentarily moving the thermostat control (system) switch to OFF, then back to HEAT or COOL (or AUTO).

The lockout circuit can also be reset by opening and closing the unit-mounted disconnect switch.

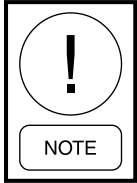

***If the unit must be reset more than twice on consecutive operating cycles, check the unit for a dirty filter, an abnormal entering water temperature, an inadequate or excessive water flow, or a refrigerant circuit malfunction. If the unit continues to fail, contact a trained service technician.***

## Operation Errors

Each refrigerant system is monitored for operation outside of the intended parameters. Errors are handled as described below. All system errors override minimum runtimes for compressors.

### High Pressure Limit Switch

If a high pressure limit switch opens, the microprocessor control de-energizes the compressor, initiates the ASCD, and stops the unit fans (a soft lockout). At the conclusion of the ASCD, if a call for cooling or heating is still present, the microprocessor control re-energizes the compressor and unit fan.

If a high pressure limit switch opens three times within 2 hours of operation, the microprocessor control permanently locks out the system compressor, requiring a manual reset of the system (a hard lockout). To manually reset, either de-energize the 24 volt power to the unit or turn the room thermostat to the OFF position, then back to either heating or cooling as required. The microprocessor control flashes a fault code indicating the high pressure lockout (see *Table 24 on page 45*).

### Low Pressure Limit Switch

The microprocessor does not monitor the low pressure limit switch during the initial 30 seconds of compressor operation. For the following 30 seconds, the microprocessor control monitors the low pressure limit switch to ensure it closes. If the low pressure limit switch fails to close after the 30 second monitoring phase, the microprocessor control de-energizes the compressor, initiates the ASCD, and stops the fan (a soft lockout).

Once the low pressure limit switch is proven (closed during the 30 second monitoring period), the microprocessor control monitors the low pressure limit switch

for any openings. If the low pressure limit switch opens for more than 5 seconds, the microprocessor control de-energizes the compressor, initiates the ASCD, and stops the compressor (a soft lockout).

If the call for cooling is still present at the end of the ASCD, the microprocessor control re-energizes the compressor.

If a low pressure limit switch opens three times within 1 hour of operation, the microprocessor control board locks out the compressor (a hard lockout) and flashes a fault code (see *Table 24 on page 45*).

### Freeze-stat

If a freeze-stat opens, the microprocessor control de-energizes the compressor and initiates the ASCD. If a call for cooling or heating is still present at the conclusion of the ASCD, the microprocessor control re-energizes the halted compressor.

### Condensate Overflow Switch

A condensate overflow fault occurs if the condensate overflow switch opens continuously for 30 seconds. The compressor shuts down regardless of the minimum runtime, and alarm 15 sets. The fan continues operating in its current state.

The microprocessor control logs the first incident per compressor request. Lockout occurs on the second fault occurrence within a request cycle, requiring reset or power cycling. If the compressor request is removed, the fault occurrence counter resets to zero. When lockouts are removed, the alarm resets.

## Safety Controls

The microprocessor control monitors the following inputs:

- A suction line freeze-stat to protect against low leaving water temperatures (opens at 34.0°F and resets at 48.0°F).
- A high pressure limit switch to protect against excessive discharge pressures (opens at 600 psig +/- 25 psig).
- A low pressure limit switch to protect against loss of refrigerant charge (opens at 55 psig +/- 5 psig).
- A condensate overflow switch to protect against condensate overflow

### Coaxial Freeze Protection Set Point

The field can select the coaxial freeze protection set point. The unit uses a suction line freeze-stat factory set for compressor lockout when the leaving water temperature drops below 35.0°F (resets at 48.0°F). To lower the set point for low temperature heating applications with an adequate water-antifreeze solution, unplug the freeze-stat sensor (at P6 on the microprocessor control board) and plug in the (pink) jumper attached to the existing harness. Installing the jumper bypasses the freeze-stat, enabling a heating operation with a leaving water temperature below 35.0°F. Use the jumper only in low water applications with adequate antifreeze protection. Otherwise, damage can occur.

### Random Start

The random start function, upon power up, imposes a time delay of 4 minutes and a random delay of 1 to 64 seconds. A combination of the following determine the random number generator seed:

- A fixed seed programmed at the factory
- The serial number
- The model number
- The hours of the unit compressor's runtime

### Compressor Protection

In addition to the external pressure switches, the compressor also has inherent internal protection. If there is an abnormal temperature rise in a compressor, the protector opens to shut down the compressor. The microprocessor control incorporates features to minimize compressor wear and damage. The control uses an ASCD to prevent compressor operation too soon after its previous run. Additionally, a minimum runtime is imposed any time a compressor energizes. The ASCD initiates on unit start-up and on any compressor reset or lockout.

### Microprocessor Control Unit Flash Codes

The microprocessor control uses various flash codes to aid in troubleshooting. The flash codes are distinguished by a short on and off cycle (approximately 200ms on and 200ms off).

During normal operation, to show that the microprocessor correctly functions, the control boards flash for 1 second on, 1 second off, also known as a heartbeat. Do not confuse this with an error flash code. To prevent confusion, a 1-flash fault code is not used. For a list of all flash codes, see *Table 24 on page 45*.

Current alarms or active restrictions are flashed on the microprocessor control LED.

1. Last Error: When this button is pressed and released one time within 5 seconds, it flashes the last five fault codes on the board's LED. The most recent alarm is shown first and the oldest alarm is shown last.
2. Test Reset: When this button is pressed and released one time with five seconds, any ASCD is bypassed for one cycle.
3. Comm Set UP: If the board is to be networked with other units, this button sets the network address.

The first time the button is pressed within 5 seconds, it scans the bus, assigns itself the first available address (starting at 2), then flashes that address once. Pressing the button twice in 5 seconds causes the control to flash the address.

**TABLE 24 - FLASH CODES**

FLASH CODES	DESCRIPTION
On Steady	Control Failure – Replace Control
Heartbeat	Normal Operation
2 Flashes	Control Waiting on Anti-Short Cycle Delay (ASCD) <sup>1</sup>
3 Flashes	HPS1 – Compressor Lockout
5 Flashes	LPS1 – Compressor Lockout
13 Flashes	Compressor Held OFF Due to Low Voltage <sup>1</sup>
14 Flashes	EEPROM Storage Failure (Control Failure)
15 Flashes	Condensate Overflow Switch – Compressor Lockout
16 Flashes	Coaxial Freeze Thermostat – Compressor Lockout

**NOTE**

1. These flash codes do not represent alarms.

### Communication

The communication protocol is MODBUS using the RTU method of packet framing at 19200-baud rate.

THIS PAGE INTENTIONALLY LEFT BLANK.

## SECTION 3 - MAINTENANCE

Unit maintenance is simplified by the following preventive suggestions:

- At least once a month, visually inspect the unit. Pay special attention to the hose assemblies. Note any signs of hose deterioration or cracking. Immediately attend to any sign of minor leakage.
- At least every three months, to ensure proper operation of the equipment, inspect the filters. Replace the filters when there is a visible buildup of dirt.

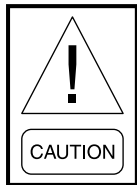

***To avoid fouled machinery and extensive unit clean up, DO NOT operate the units without the filters in place or use the unit as a temporary cooling/heating source during construction.***

- Every three months, inspect the condensate drain pan for algae growth and mineral buildup. Excessive algae or mineral deposits in the drain pan or drain line can result in condensate overflow and unpleasant mildew odors.
- Annually check the fan motor and blower assembly. All units employ permanently lubricated fan motors. **DO NOT OIL THE FAN MOTORS.** Vacuum any accumulation of dirt from the motor ventilation slots and the blower wheel.

- Annually, check the contactors and relays within the control panel. Inspect the panel for any visible signs of overheated contacts or temperature damage to the wiring. Check the terminals for tightness.
- Annually conduct an amperage check on the compressor and fan motor. An amperage draw more than 10% higher than the nameplate values can indicate heat exchanger fouling, low water flow, or a premature physical motor failure.
- At least once a year, inspect the air-to-refrigerant heat exchanger surface. A dirty or partially clogged coil can significantly reduce the operating capacity and can result in serious equipment problems. If the coils appear dirty, clean them using mild detergent or a commercial coil-cleaning agent.
- Inspect hoses, valves, and connections for water leaks. For hose connection leaks, inspect the rubber hose gaskets and replace them as required.

**TABLE 25 - WATER QUALITY TABLE**

POTENTIAL PROBLEM	CONTROLLED CHEMICAL/ CONDITION	COPPER COAXIAL HEAT EXCHANGERS RANGE	CUPRO-NICKEL COAXIAL HEAT EXCHANGERS RANGE
EROSION	Cleaning	Proper surface cleaning required	Proper surface cleaning required
	Filtration	Best practice filtration	Best practice filtration
	Suspended Solids	Less than 10 ppm	Less than 10 ppm
	Water Velocity	Less than 8 ft/s	Less than 12ft/s
BACTERIA/MOLD	Iron Bacteria	None	None
	Iron Oxide	Less than 1 ppm	Less than 1 ppm
SCALING	Calcium & Magnesium Carbonate	Less than 350 ppm	Less than 350 ppm
CORROSION	pH Range	7 to 9	5 to 9
	TDS (Total Dissolved Solids)	Less than 1000 ppm	Less than 1500 ppm
	Ammonia, Ammonium Hydroxide	Less than 0.5 ppm	Less than 0.5 ppm
	Ammonium Nitrate, Ammonium Chloride	Less than 0.5 ppm	Less than 0.5 ppm
	Calcium Chloride/Sodium Chloride	Less than 125 ppm	Less than 125 ppm
	Chlorine	Less than 0.5 ppm	Less than 0.5 ppm
	Hydrogen Sulfide	None	None

THIS PAGE INTENTIONALLY LEFT BLANK.



# APPENDIX

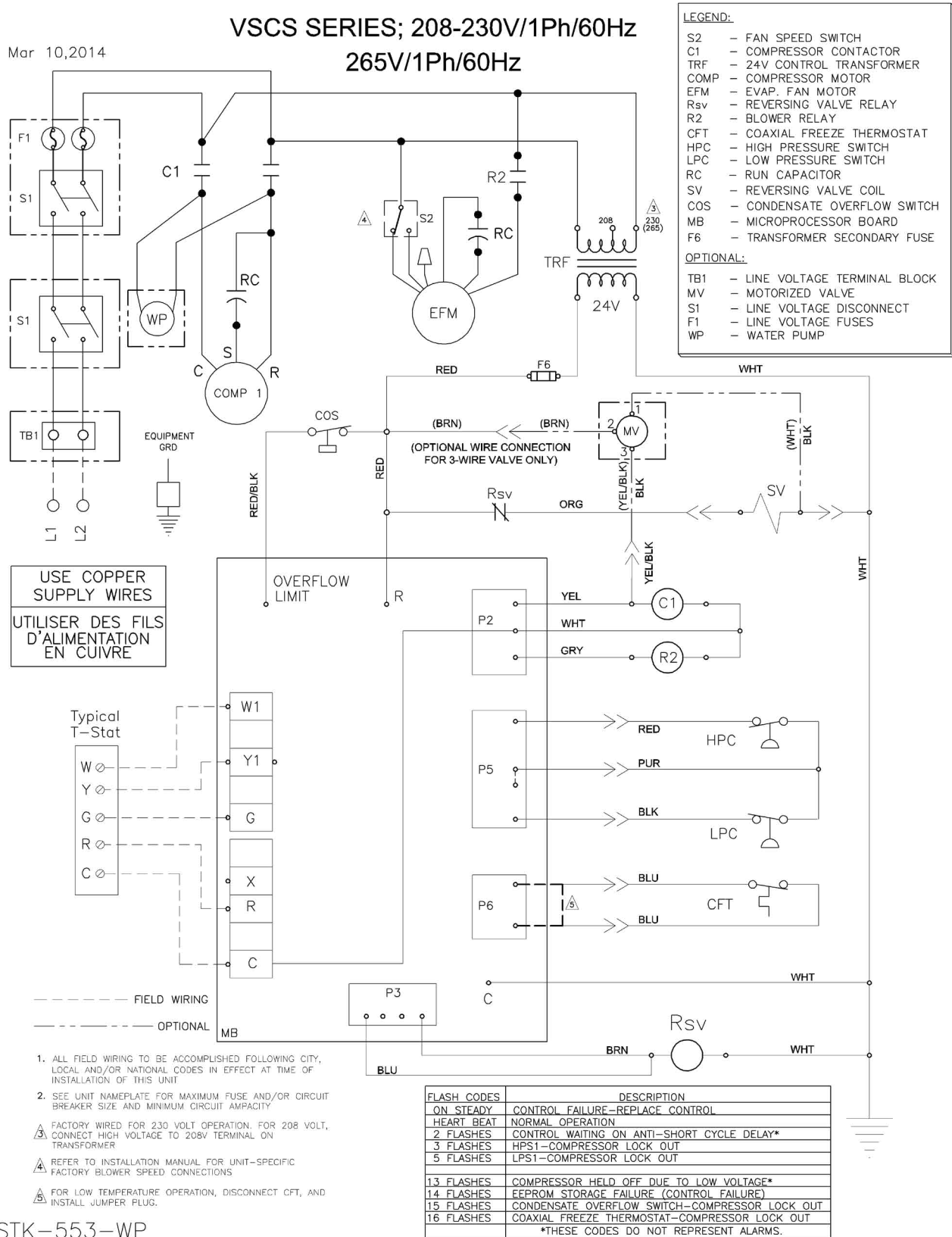

STK-553-WP

FIGURE 31 - PSC MOTOR WIRING DIAGRAM

March 10, 2014

### VSCS SERIES w/ ECM MOTOR 208-230V, 265V/1Ph/60Hz

**LEGEND:**

- S2 - FAN SPEED SWITCH
- C1 - COMPRESSOR CONTACTOR
- TRF - 24V CONTROL TRANSFORMER
- COMP - COMPRESSOR MOTOR
- ECM - EVAP. ECM FAN MOTOR
- Rsv - REVERSING VALVE RELAY
- CFT - COAXIAL FREEZE THERMOSTAT
- HPC - HIGH PRESSURE SWITCH
- LPC - LOW PRESSURE SWITCH
- SV - REVERSING VALVE COIL
- COS - CONDENSATE OVERFLOW SWITCH
- MB - MICROPROCESSOR BOARD
- F6 - TRANSFORMER SECONDARY FUSE

**OPTIONAL:**

- TB1 - LINE VOLTAGE TERMINAL BLOCK
- MV - MOTORIZED VALVE
- S1 - LINE VOLTAGE DISCONNECT
- F1 - LINE VOLTAGE FUSES
- WP - WATER PUMP

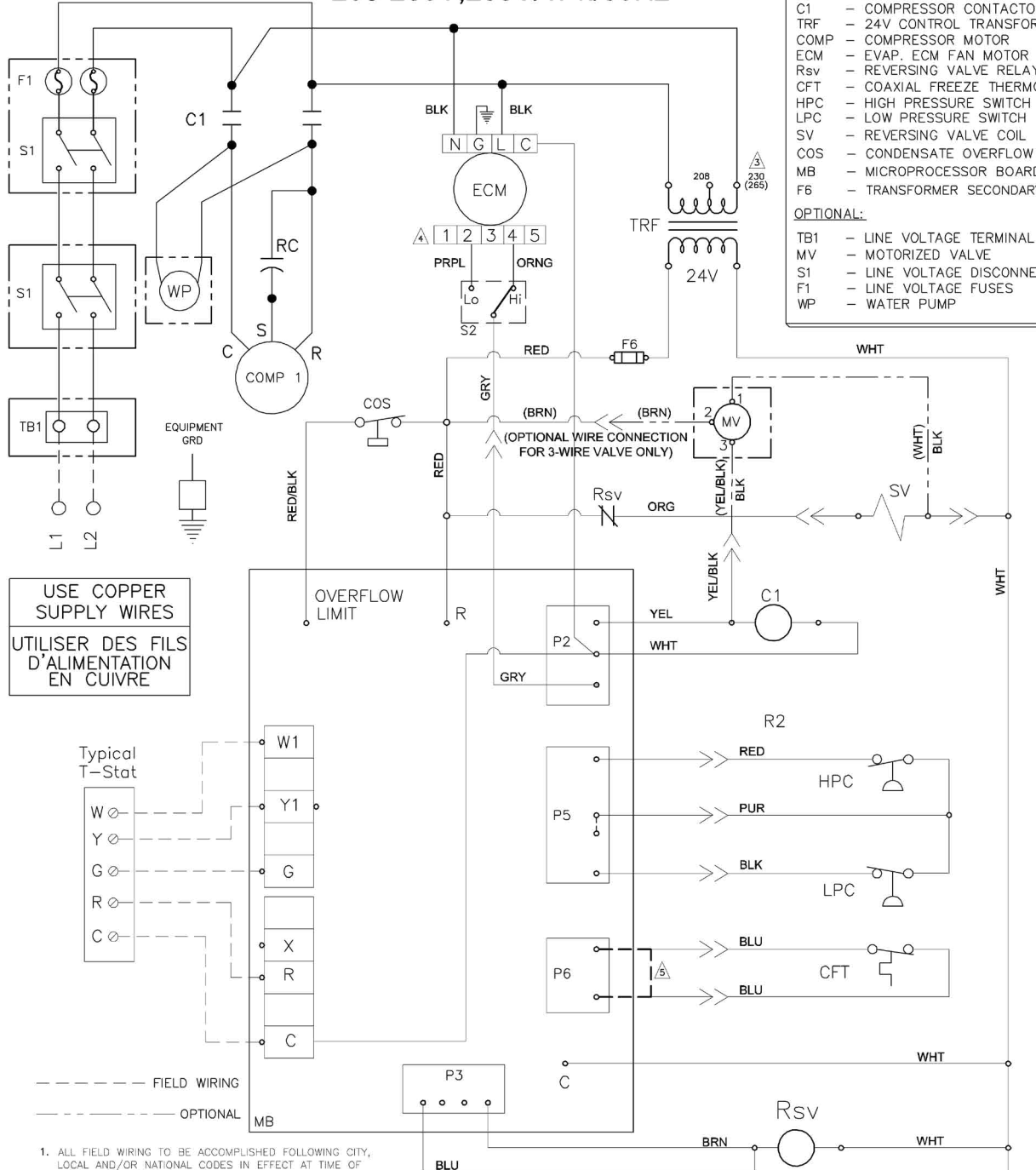

USE COPPER SUPPLY WIRES  
UTILISER DES FILS D'ALIMENTATION EN CUIVRE

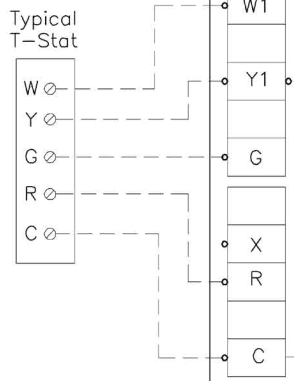

--- FIELD WIRING  
- - - - - OPTIONAL

1. ALL FIELD WIRING TO BE ACCOMPLISHED FOLLOWING CITY, LOCAL AND/OR NATIONAL CODES IN EFFECT AT TIME OF INSTALLATION OF THIS UNIT
2. SEE UNIT NAMEPLATE FOR MAXIMUM FUSE AND/OR CIRCUIT BREAKER SIZE AND MINIMUM CIRCUIT AMPACITY
- ▲ FACTORY WIRED FOR 230 VOLT OPERATION. FOR 208 VOLT, CONNECT HIGH VOLTAGE TO 208V TERMINAL ON TRANSFORMER
- ▲ REFER TO INSTALLATION MANUAL FOR UNIT-SPECIFIC FACTORY BLOWER SPEED CONNECTIONS
- ▲ FOR LOW TEMPERATURE OPERATION, DISCONNECT CFT, AND INSTALL JUMPER PLUG.

FLASH CODES	DESCRIPTION
ON STEADY	CONTROL FAILURE-REPLACE CONTROL
HEART BEAT	NORMAL OPERATION
2 FLASHES	CONTROL WAITING ON ANTI-SHORT CYCLE DELAY*
3 FLASHES	HPS1-COMPRESSOR LOCK OUT
5 FLASHES	LPS1-COMPRESSOR LOCK OUT
13 FLASHES	COMPRESSOR HELD OFF DUE TO LOW VOLTAGE*
14 FLASHES	EEPROM STORAGE FAILURE (CONTROL FAILURE)
15 FLASHES	CONDENSATE OVERFLOW SWITCH-COMPRESSOR LOCK OUT
16 FLASHES	COAXIAL FREEZE THERMOSTAT-COMPRESSOR LOCK OUT

\*THESE CODES DO NOT REPRESENT ALARMS.

STK-554-WP

**FIGURE 32 - ECM WIRING DIAGRAM**

## VSCS SERIES w/ ECM MOTOR; 208-230V/1Ph/60Hz 265V/1Ph/60Hz

Aug 14, 2013

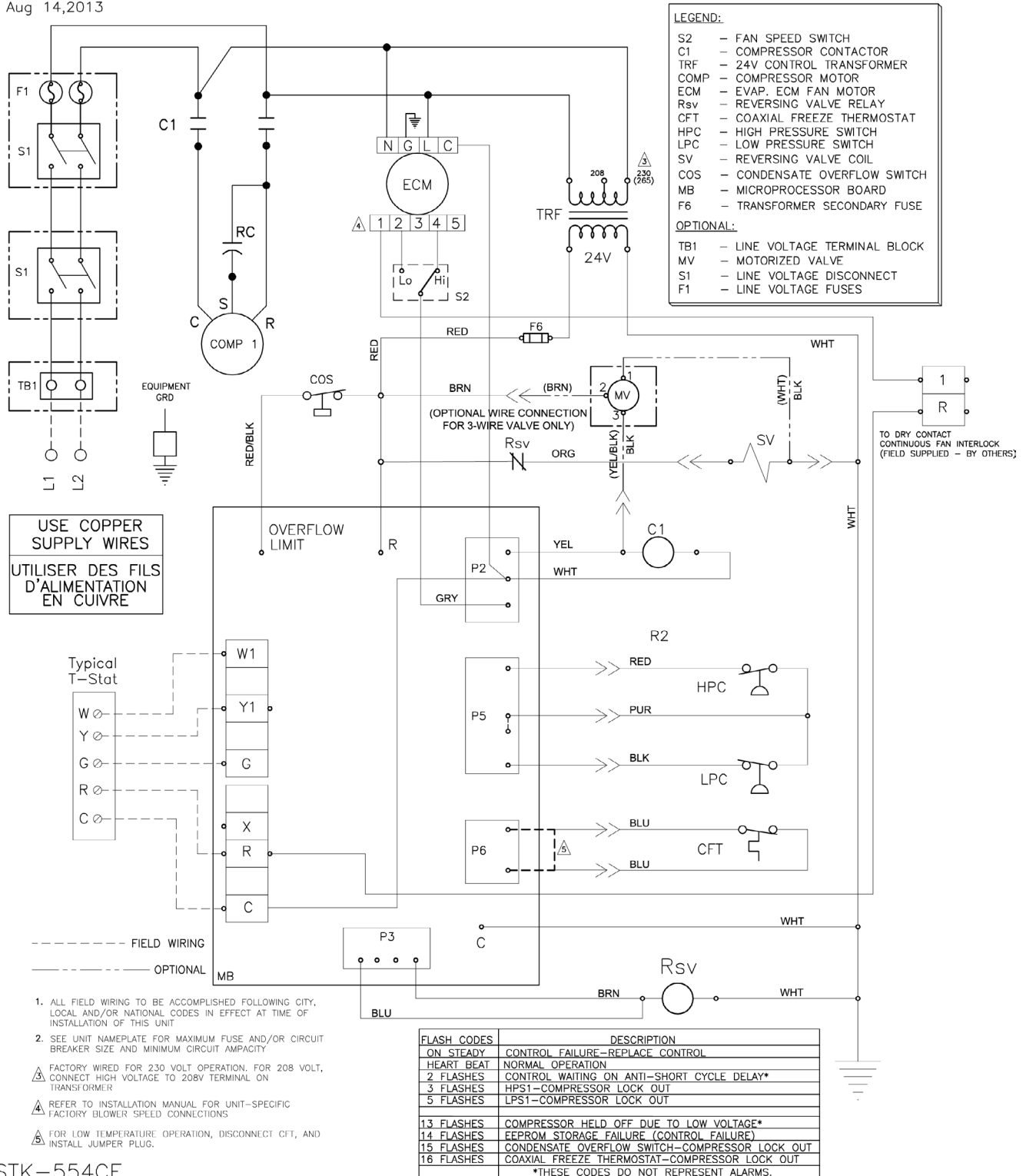

STK-554CF

**FIGURE 33 - CONTINUOUS FAN WITH ECM WIRING DIAGRAM**

LD23573

VSCS SERIES w/ ECM MOTOR; 208-230V/1Ph/60Hz  
265V/1Ph/60Hz

OCT 2014

- LEGEND:**
- S2 - FAN SPEED SWITCH
  - C1 - COMPRESSOR CONTACTOR
  - TRF - 24V CONTROL TRANSFORMER
  - COMP - COMPRESSOR MOTOR
  - ECM - EVAP. ECM FAN MOTOR
  - Rsv - REVERSING VALVE RELAY
  - CFT - COAXIAL FREEZE THERMOSTAT
  - HPC - HIGH PRESSURE SWITCH
  - LPC - LOW PRESSURE SWITCH
  - SV - REVERSING VALVE COIL
  - COS - CONDENSATE OVERFLOW SWITCH
  - MB - MICROPROCESSOR BOARD
  - F6 - TRANSFORMER SECONDARY FUSE
  - DMP - MOTORIZED FRESH AIR DAMPER
- OPTIONAL:**
- TB1 - LINE VOLTAGE TERMINAL BLOCK
  - MV - MOTORIZED VALVE
  - S1 - LINE VOLTAGE DISCONNECT
  - F1 - LINE VOLTAGE FUSES
  - WP - WATER PUMP
  - DMP - MOTORIZED FRESH AIR DAMPER

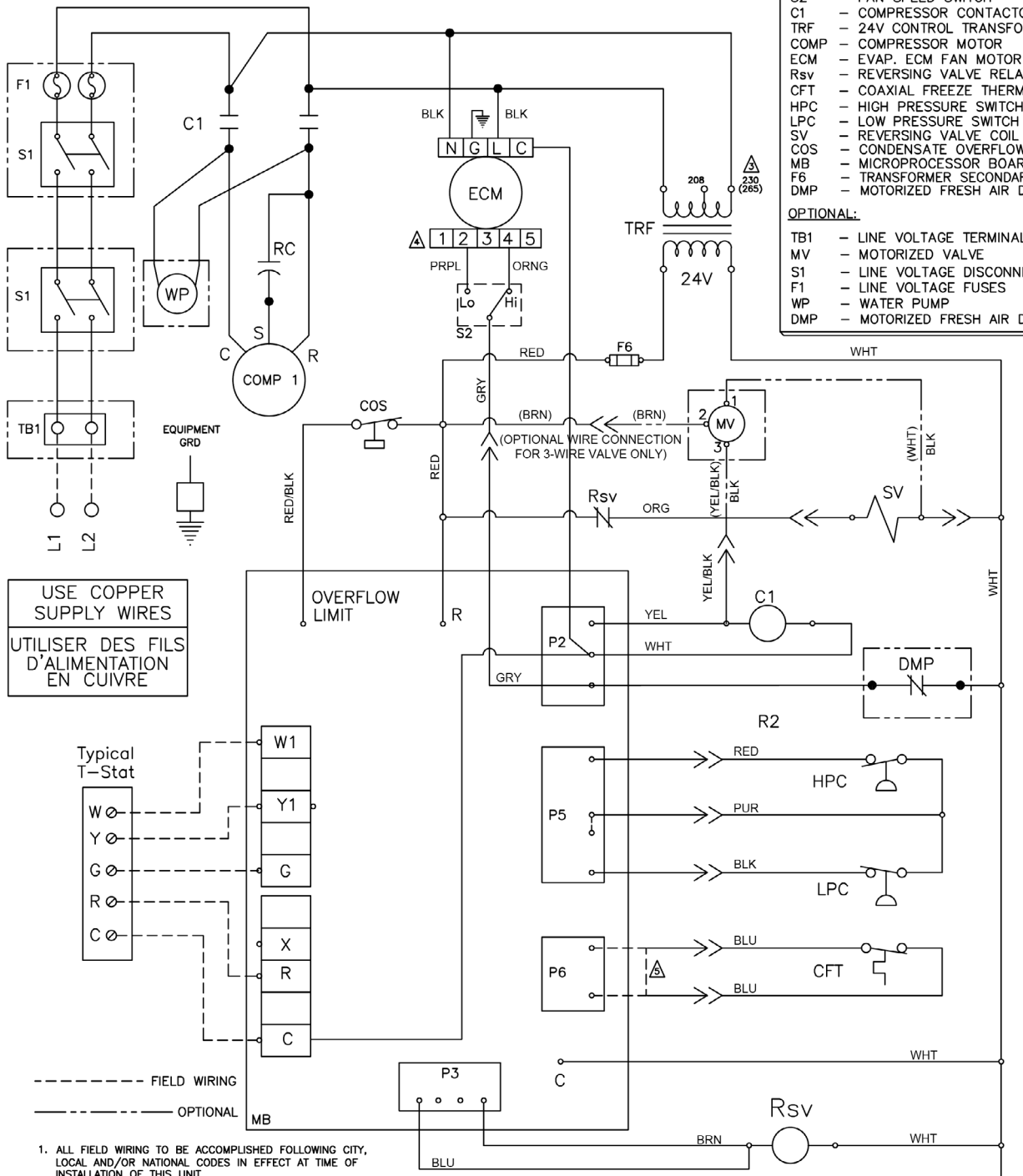

USE COPPER SUPPLY WIRES  
UTILISER DES FILS D'ALIMENTATION EN CUIVRE

1. ALL FIELD WIRING TO BE ACCOMPLISHED FOLLOWING CITY, LOCAL AND/OR NATIONAL CODES IN EFFECT AT TIME OF INSTALLATION OF THIS UNIT
  2. SEE UNIT NAMEPLATE FOR MAXIMUM FUSE AND/OR CIRCUIT BREAKER SIZE AND MINIMUM CIRCUIT AMPACITY
- ⚠ FACTORY WIRED FOR 230 VOLT OPERATION. FOR 208 VOLT, CONNECT HIGH VOLTAGE TO 208V TERMINAL ON TRANSFORMER
  - ⚠ REFER TO INSTALLATION MANUAL FOR UNIT-SPECIFIC FACTORY BLOWER SPEED CONNECTIONS
  - ⚠ FOR LOW TEMPERATURE OPERATION, DISCONNECT CFT, AND INSTALL JUMPER PLUG.

FLASH CODES	DESCRIPTION
ON STEADY	CONTROL FAILURE-REPLACE CONTROL
HEART BEAT	NORMAL OPERATION
2 FLASHES	CONTROL WAITING ON ANTI-SHORT CYCLE DELAY*
3 FLASHES	HPS1-COMPRESSOR LOCK OUT
5 FLASHES	LPS1-COMPRESSOR LOCK OUT
13 FLASHES	COMPRESSOR HELD OFF DUE TO LOW VOLTAGE*
14 FLASHES	EEPROM STORAGE FAILURE (CONTROL FAILURE)
15 FLASHES	CONDENSATE OVERFLOW SWITCH-COMPRESSOR LOCK OUT
16 FLASHES	COAXIAL FREEZE THERMOSTAT-COMPRESSOR LOCK OUT
*THESE CODES DO NOT REPRESENT ALARMS.	

STK-554DMP

FIGURE 34 - MOTORIZED DAMPER ECM WIRING DIAGRAM

LD23574

## R-410A QUICK REFERENCE GUIDE

See *Section 1 - Installation* for specific installation requirements.

- R-410A refrigerant operates at 50–70% higher pressures than R-22. Ensure that servicing equipment and replacement components are designed to operate with R-410A.
- R-410A refrigerant cylinders are rose colored.
- Recovery cylinder service pressure rating must be 400 psig (DOT 4BA400 or DOT BW400).
- Recovery equipment must be rated for R-410A.
- Do not use R-410A service equipment on R-22 systems. All hoses, gages, recovery cylinders, charging cylinders, and recovery equipment must be dedicated for use on R-410A systems only.
- Manifold sets must be at least 700 psig high side and 180 psig low side with 550 psig retard.
- All hoses must have a service pressure rating of 800 psig.
- Leak detectors must be designed to detect HFC refrigerants.
- Systems must be charged with refrigerant. Use a commercial type metering device in the manifold hose.
- R-410A can only be used with POE type oils.
- POE type oils rapidly absorb moisture from the atmosphere.
- Vacuum pumps will not remove moisture from POE type oils.
- Do not use liquid line driers with a rated working pressure rating less than 600 psig.
- Do not install suction line driers in the liquid line.
- A liquid line drier is required on every unit.
- Do not use an R-22 TXV. If a TXV is necessary, it must be an R-410A TXV.
- Never open system to atmosphere when under vacuum.
- If system must be opened for service, evacuate system then break the vacuum with dry nitrogen and replace filter driers.



P.O. Box 1592, York, Pennsylvania USA 17405-1592  
Copyright © by Johnson Controls 2018  
Form 145.18-IOM3 (218)  
Issue Date: February 28, 2018  
New Release

800-861-1001  
[www.johnsoncontrols.com](http://www.johnsoncontrols.com)

Subject to change without notice. Printed in USA  
ALL RIGHTS RESERVED